

PNEG-1319  
**BEARING SUPPORT KIT**  
INSTALLATION INSTRUCTIONS

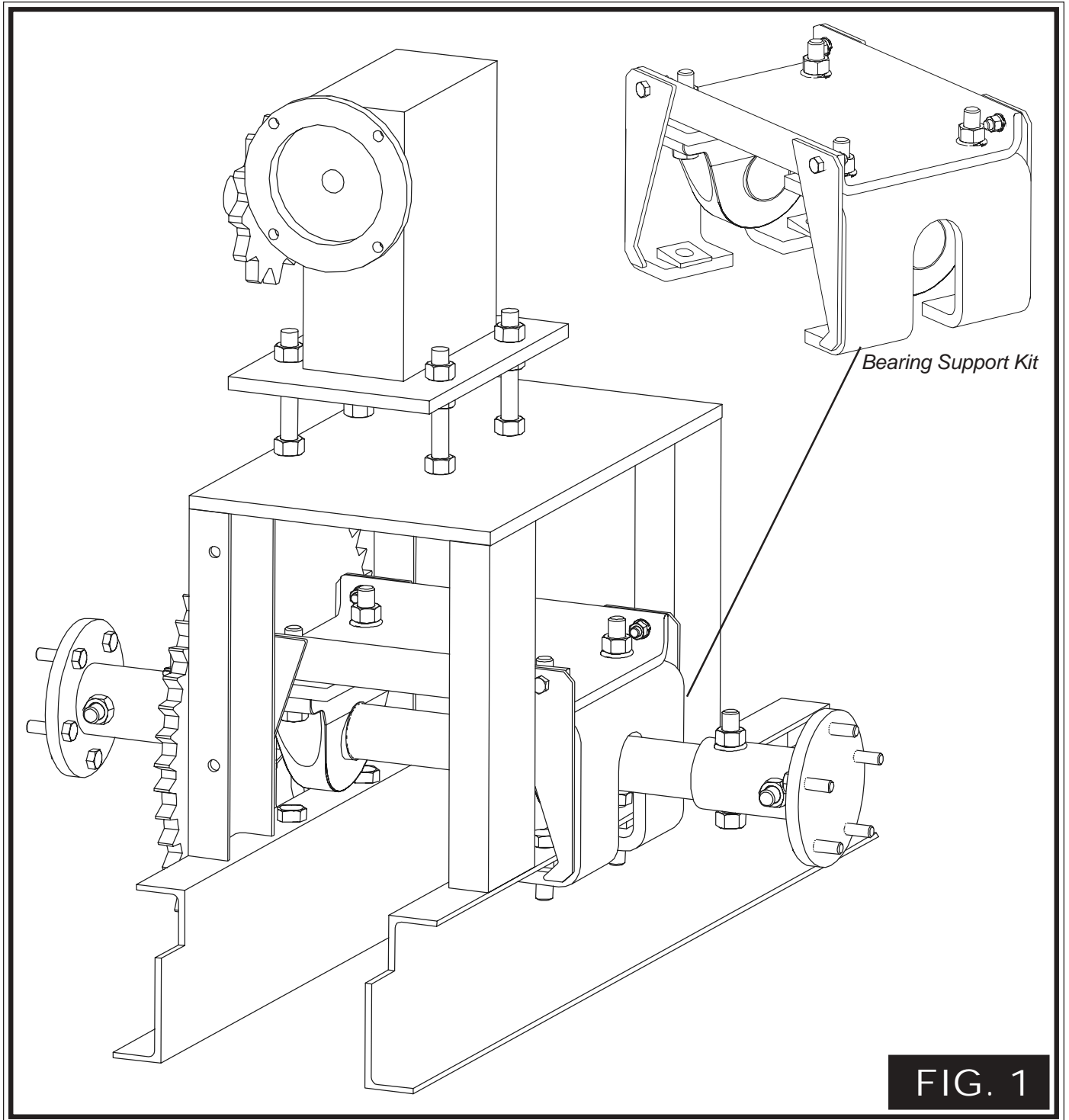

THE GSI GROUP  
1004 E. ILLINOIS ST.  
ASSUMPTION, IL 62510  
PHONE: (217)-226-4421  
DATE: 05-13-03



## INSTALLING BEARING SUPPORT KIT

1. Turn off and lock out power source.
2. Loosen set screws on bearings.
3. Slide bearing away from sprocket to make room to guide end plates around channels.
4. Replace standard grease zerks with 90° grease zerks on both bearings. Make sure the 90° grease zerk is turned as shown in Figure 2, so the zerks are accessible.
5. Turn the bearings so the base is facing up before attaching the bearing mount end plates as shown in Figure 3.
6. Guide bearing mount end plates onto shaft and hook under the channels, lining up the bolt holes with the holes where the bearings were previously attached. (See Figure 1.) Fasten bearing mount end plates to channels using (4) 5/8" x 2-1/2" Zinc GR8 bolts, beveled washers, lock washers, and hex nuts as shown in Figure 4 & 5.
7. Attach the bearing mount top plate to the bearing mount end plates using (4) 3/8" x 1-1/4" GR5 bolts with split lock washers and hex nuts. Bolt heads should be against the end plates as shown in Figure 4 & 5.
8. Slide bearings into position under bearing mount end plate, the holes should line up.
9. Fasten the bearings to the end plates and top plate using (4) 5/8" x 3" GR8 bolt with lock washers and hex nuts. The bolt heads should rest against the bearings. Tighten set screws on bearings. (See Figure 4 & 5.)

**NOTE**

Make sure bearing mount end plates are fully tightened so bearings slide under plates without hitting the channels.

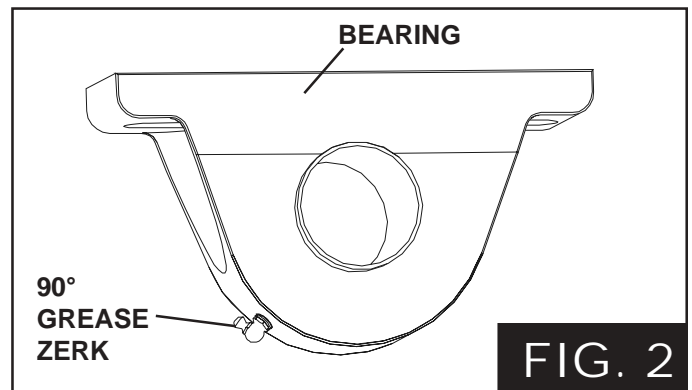

**FIG. 2**

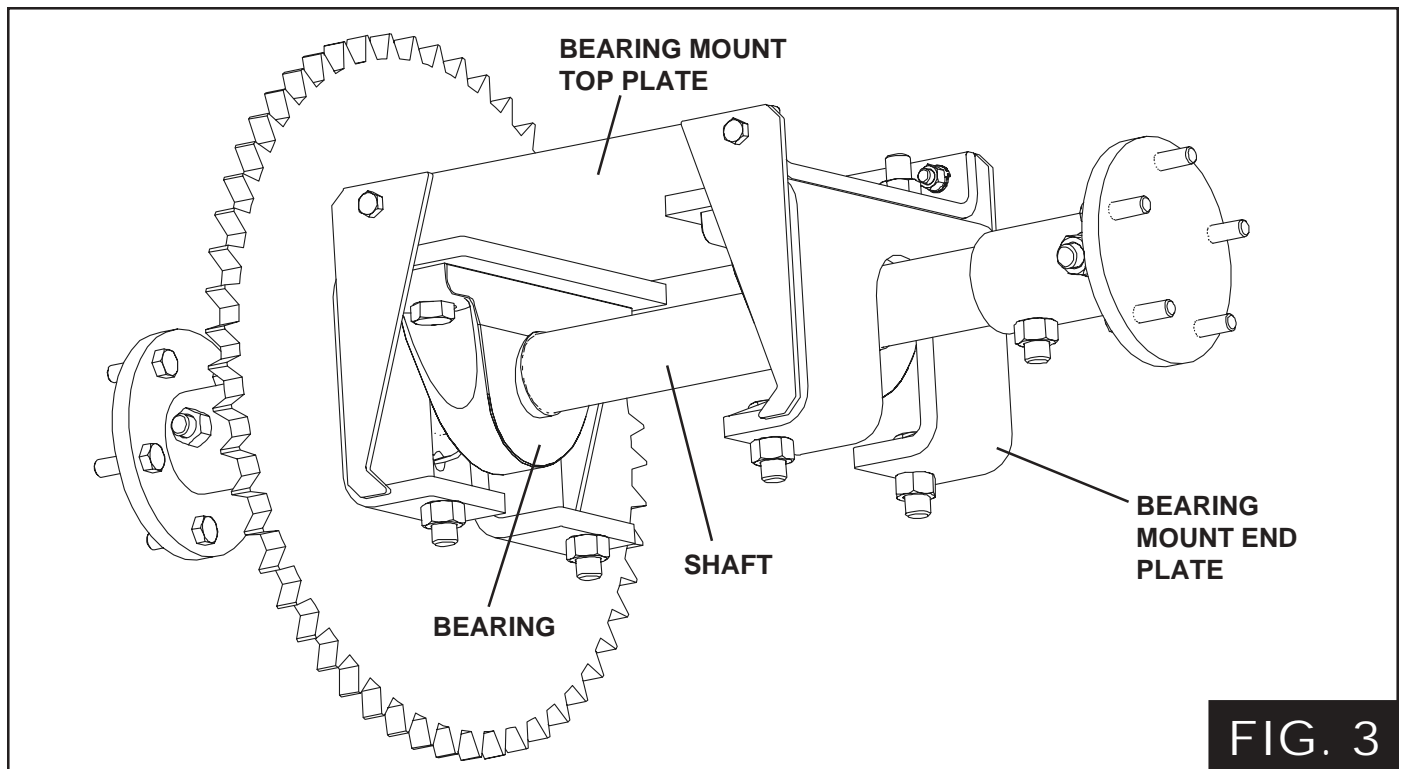

**FIG. 3**



