



Assembling Wire Grill Guard Roof Vent

The following instructions are for assembling the wire grill guard roof vent. Before beginning assembly, check the packing list to ensure all components have been received. The unit is easiest assembled in the upside-down position as shown in the instructions.

1. Take all parts out of the shipping box and ensure all parts are present.
2. Turn the roof vent housing assembly (D) upside down.
3. Install a hex bolt (B) through the hole on the side of roof vent housing (D). Install a flange nut (E) to the hex bolt (B) and tighten.
4. With the eyelid tabs upward, install the wire grill guard assembly (F) into the roof vent housing (D) and onto the end of the hex bolt (B).
5. Insert another hex bolt (B) through the other side of the roof vent housing (D) and install a flange nut (E) to the hex bolt (B), insert the eyelet of the grill guard assembly (F) onto the edge of the hex bolt (B).
6. Apply a strip of caulking around the three (3) housing sides of the roof vent assembly (D) where it meets the hold-down angle (A).
7. Place the hold-down angle (A) onto the assembled roof vent assembly (D), with the wide end or long end of the hold-down angle (A) facing the vent discharge and the short end facing the rear of the wire grill vent.
8. When the hold-down angle (A) is aligned, install #10 self-drilling screws (C) through the roof vent housing and into the hold-down angle (A).

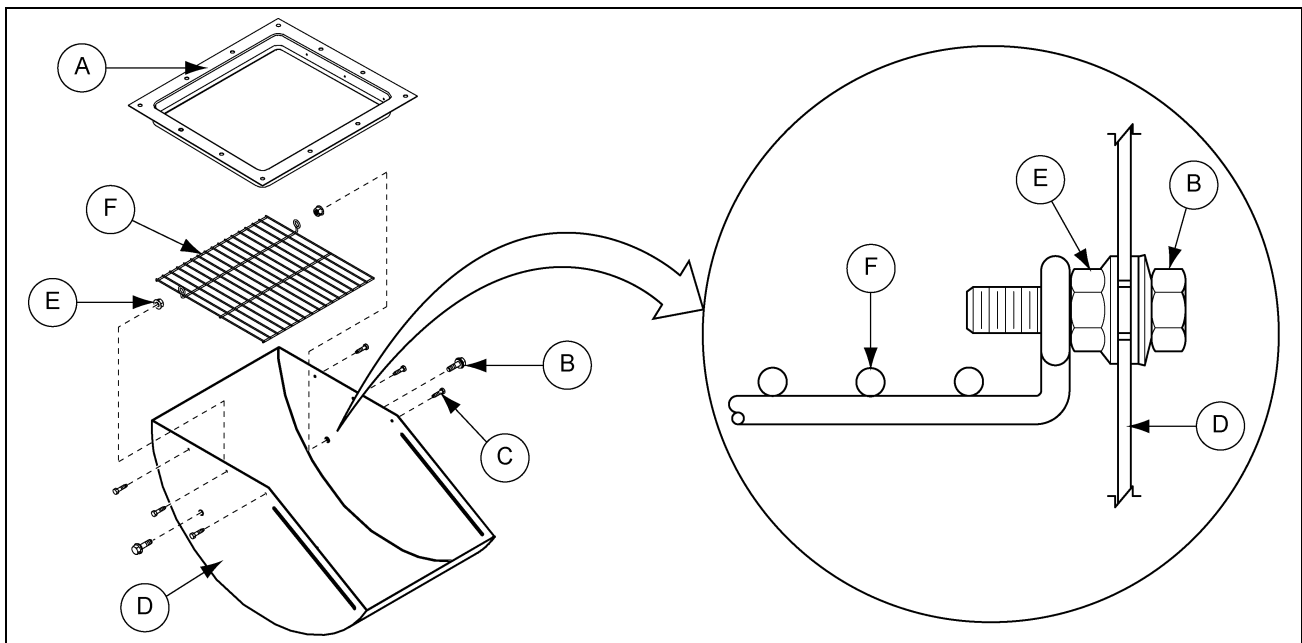

Figure 1 Grill Guard Roof Vent Assembly

Ref #	Part #	Description
A	MIS-4404	Hold-Down Angle
B	S-7483	5/16" x 1-1/4" Hex Bolt
C	S-280	#10 Self-Drilling Screw

Ref #	Part #	Description
D	MIS-6778	Roof Vent Housing Assembly
E	S-3611	5/16" Flange Nut
F	MIS-6766	Wire Grill Guard Assembly

Date: 03-04-14

Printed in the U.S.A.
Copyright © 2014 by GSI Group
www.gsiag.com



PNEG-248

PNEG-248

Page 1 of 2

CN-310916

Wire Grill Guard Vent Instructions

Installing Wire Grill Guard Roof Vent

The following instructions are for installing the wire grill guard roof vent.

Before You Begin

The wire grill guard roof vent must be assembled prior to installing.

1. If the roof panel (E) does not have a pre-punched hole for the roof vent assembly (D), a hole must be cut. The cut hole should match the roof vent assembly (D). The hole's inside edge should be approximately 15" (F) from the roof panel eave.
2. Place the three (3) foam strips (B) on the roof panel (E), as shown and position the roof vent assembly (D) over the foam strips (B). Install bolts (A) and nuts (C), securing the roof vent assembly (D) to the roof panel (E).
3. Install bolts (A) and nuts (C) from the underside of the roof panel (E) securing the front of the hold-down angle to the roof panel as shown in [Figure 2](#). Tighten the hardware to the recommended torque specifications. See bolt torque specifications.

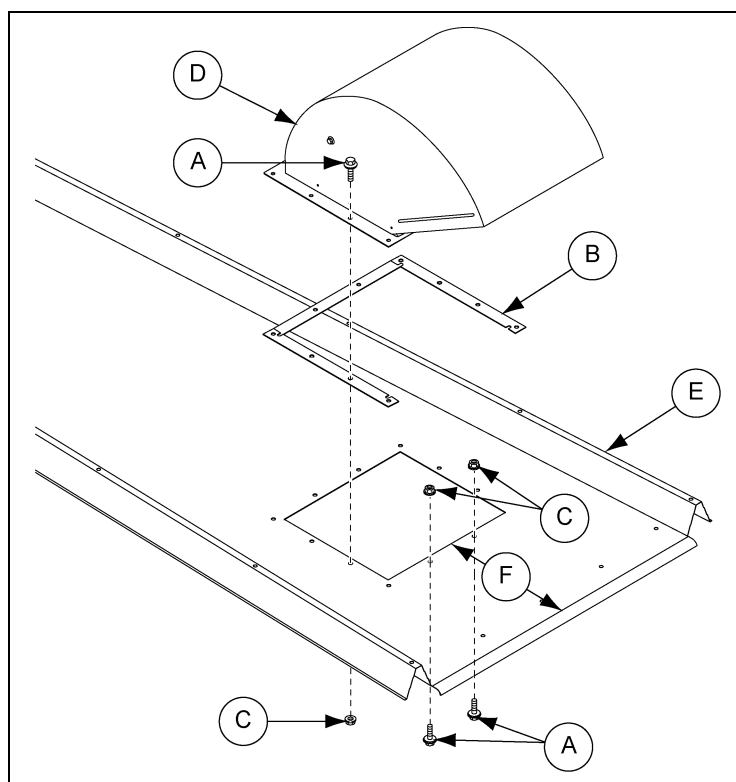

Figure 2 Exploded View of Vent Housing to Roof Panel

Ref #	Part #	Description
A	S-10260	5/16" x 1" Flange Bolt
B	MIS-6781	Foam Strips (Side Strips)
B	MIS-6780	Foam Strips (Top Strip)
C	S-3611	5/16" Flange Nut

Ref #	Description
D	Roof Vent Assembly
E	Roof Panel (Part Number Varies)
F	Approximately 15" (0.381 m) from the roof panel eave.

4. Apply caulk to all holes, ensuring a tight seal.