



**66' 40-Series - 2.66" Corrugation
Commercial Stiffened
(CTS Stiffened) Concrete
Foundation Manual**

(66' Diameter, 12 to 40 Rings)

Instructions Manual

PNEG-2097

Version: 1.1

Date: 03-07-17



PNEG-2097

All information, illustrations, photos and specifications in this manual are based on the latest information available at the time of publication. The right is reserved to make changes at any time without notice.

Contents

Chapter 1 General Overview4
 General Information 4
 Anchor Bolt Detail (CTS Stiffeners) 4
 Anchor Bolt Charts (CTS Stiffeners) 5
 Vane Axial Fan Pad 7
 Centrifugal Fan Pad 8

Chapter 2 Inverted “T” Foundation9
 66’ Diameter, 12-24 Ring (2.66” Corrugation), 3000 PSF Allowable Soil Bearing Capacity 9
 66’ Diameter, 12-24 Ring (2.66” Corrugation), 3500 PSF Allowable Soil Bearing Capacity 11
 66’ Diameter, 26-27 Ring (2.66” Corrugation), 3500 PSF Allowable Soil Bearing Capacity 13
 66’ Diameter, 12-24 Ring (2.66” Corrugation), 4000 PSF Allowable Soil Bearing Capacity 15
 66’ Diameter, 26-30 Ring (2.66” Corrugation), 4000 PSF Allowable Soil Bearing Capacity 17
 66’ Diameter, 32 Ring (2.66” Corrugation), 4500 PSF Allowable Soil Bearing Capacity 19
 66’ Diameter, 34 Ring (2.66” Corrugation), 5000 PSF Allowable Soil Bearing Capacity 21
 66’ Diameter, 37 Ring (2.66” Corrugation), 5500 PSF Allowable Soil Bearing Capacity 23
 66’ Diameter, 40 Ring (2.66” Corrugation), 6000 PSF Allowable Soil Bearing Capacity 25

Chapter 3 Frost Free Pad Foundation27
 66’ Diameter, 12-24 Ring (2.66” Corrugation) Frost Free Pad,
 3000 PSF Allowable Soil Bearing Capacity 27
 66’ Diameter, 12-24 Ring (2.66” Corrugation) Frost Free Pad,
 3500 PSF Allowable Soil Bearing Capacity 29
 66’ Diameter, 26 Ring (2.66” Corrugation) Frost Free Pad,
 3500 PSF Allowable Soil Bearing Capacity 31
 66’ Diameter, 12-24 Ring (2.66” Corrugation) Frost Free Pad,
 4000 PSF Allowable Soil Bearing Capacity 33
 66’ Diameter, 26-28 Ring (2.66” Corrugation) Frost Free Pad,
 4000 PSF Allowable Soil Bearing Capacity 35

Chapter 4 Warranty37

1. General Overview

General Information

The foundation recommendations in this manual are for use with 2.66" Corrugation 40-Series stiffened bins with CTS stiffeners.

Foundation recommendation charts are provided as an aid in material estimation purposes for standard commercial bin design conditions. Seismic conditions are not considered.

Soil bearing shall be confirmed by geotechnical investigation.

This document only provides estimation aids for frost free and inverted "T" style foundations for CTS stiffened 2.66" bins. Refer to the other appropriate GSI foundation estimation documents for other style foundations and sizes.

Anchor Bolt Detail (CTS Stiffeners)

The following is the minimum requirement for anchoring of standard tanks. Refer to sidedraw instructions for special anchoring details.

1. 3/4" Diameter anchor bolt (A) is the minimum allowed, 1" diameter anchor bolt (A) is the minimum with sidedraw flume system.
2. Exposed anchor bolt thread height (B) is 5" (12.7 cm).
3. Overall anchor bolt length (C) for 3/4" and 1" diameter anchor bolt is 18" (45.72 cm). *(See Figure 1A.)*

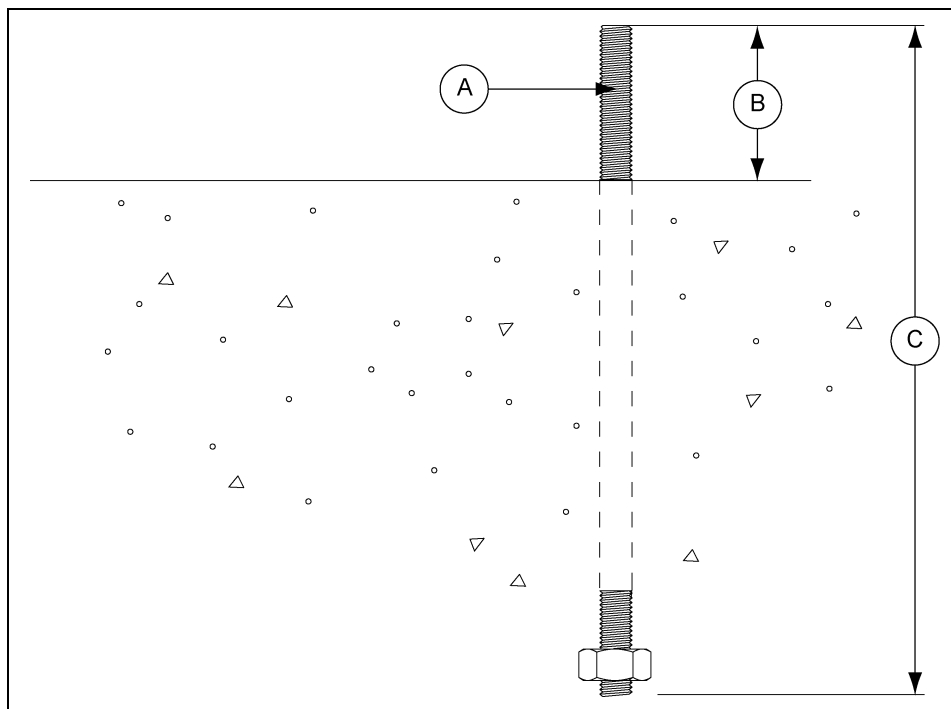

Figure 1A Anchor Bolt Example (3/4" Diameter Anchor Bolt Shown)

Ref #	Description
A	Anchor Bolt
B	Anchor Bolt Thread Height
C	Anchor Bolt Length

Anchor Bolt Charts (CTS Stiffeners)

Prior to setting any anchor bolts, you must be sure to have the correct anchor bolt placement chart. This is very critical for stiffener alignment during erection.

The charts are divided up based on the following criteria:

- Does your bin have 2 or 3 stiffeners per sidewall sheet?
- What diameter of bin do you have?

Refer to proper chart on [Page 6](#) to find the anchor chord that corresponds to the bin that is going to be built.

Start with one anchor bolt and work from it to the left to locate one quarter of the anchor bolts then to the right to locate another quarter of the bolts. Now work off of the last anchor bolts in each quarter to locate remaining anchor bolts in the last two (2) quarters. Anchor bolt radius tolerance = +/- 1/4" (7 mm).

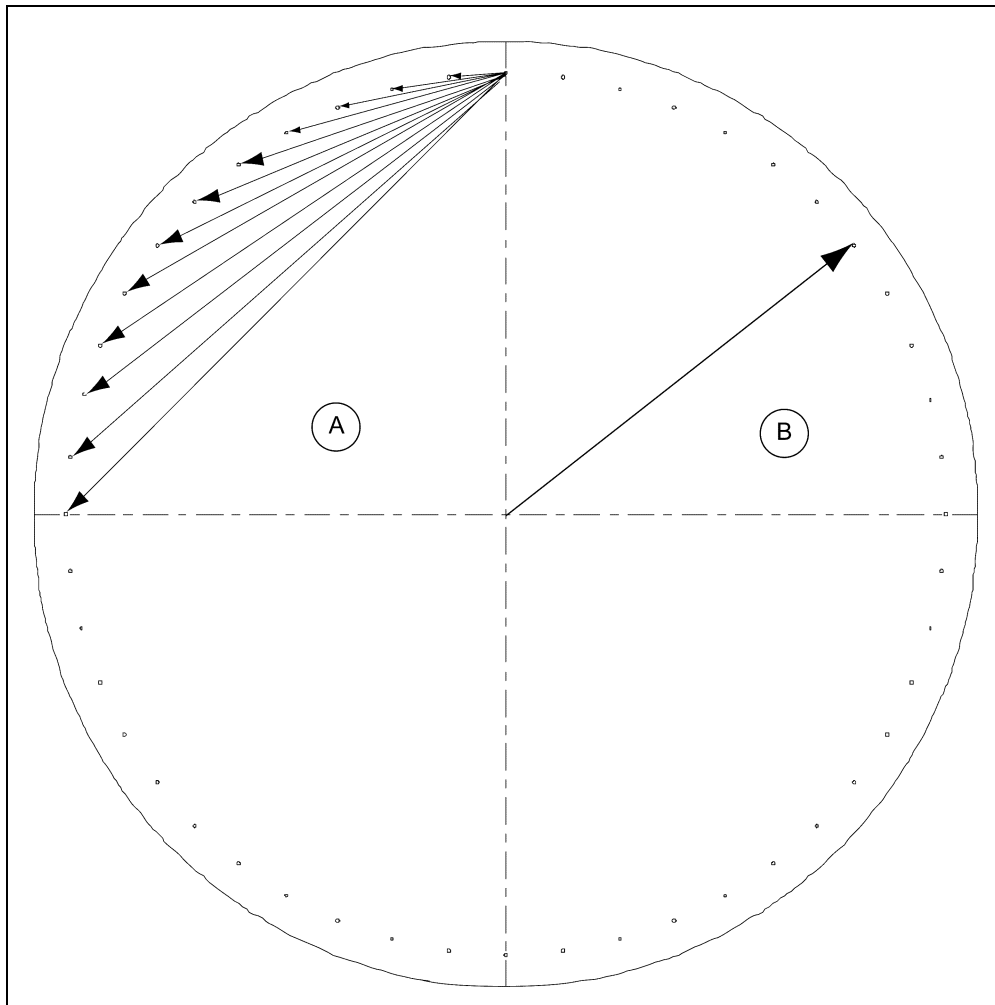

Figure 1B

Ref #	Description
A	Anchor Chord Dimensions
B	Bolt Radius

1. General Overview

Anchor Bolt Placement Charts

Nominal	44 Anchors
Diameter	= 66' 2 Post
Bolt Radius	= 33' - 2-11/16"
Anchor Chord	4' - 8-7/8"
	9' - 5-1/2"
	14' - 1-1/2"
	18' - 8-5/8"
	23' - 2-1/2"
	27' - 7-1/4"
	31' - 10-1/8"
	35' - 11-1/8"
	39' - 9-7/8"
	43' - 6-3/16"
46' - 11-7/8"	

Nominal	66 Anchors
Diameter	= 66' 3 Post
Bolt Radius	= 33' - 2-11/16"
Anchor Chord	3' - 2"
	6' - 3-13/16"
	9' - 5-1/2"
	12' - 6-15/16"
	15' - 8"
	18' - 8-11/16"
	21' - 8-13/16"
	24' - 8-3/8"
	27' - 7-5/16"
	30' - 5-7/16"
	33' - 2-3/4"
	35' - 11-1/8"
	38' - 6-9/16"
	41' - 15/16"
43' - 6-3/16"	
45' - 10-5/16"	

Vane Axial Fan Pad

Placement of the Fan Pad: Transitions/Fans/Heaters Only.

If a fan or fan and heater will be installed, refer to *Figure 1C* to determine the concrete pad size.

1. The top of this pad should be level with the top of the bin's foundation.
2. Recommended pad thickness is 4" minimum.
3. Front of pad should be perpendicular to bin wall.
4. Pad for heater not required, but if it is to added, pour the pad to cover both locations.

For fans and transitions used in aeration duct system applications, refer the transition and aeration installation instructions.

IMPORTANT: *Fan pad and fan must be level and smooth for proper operation. Vibration problems can result from improper fan leveling.*

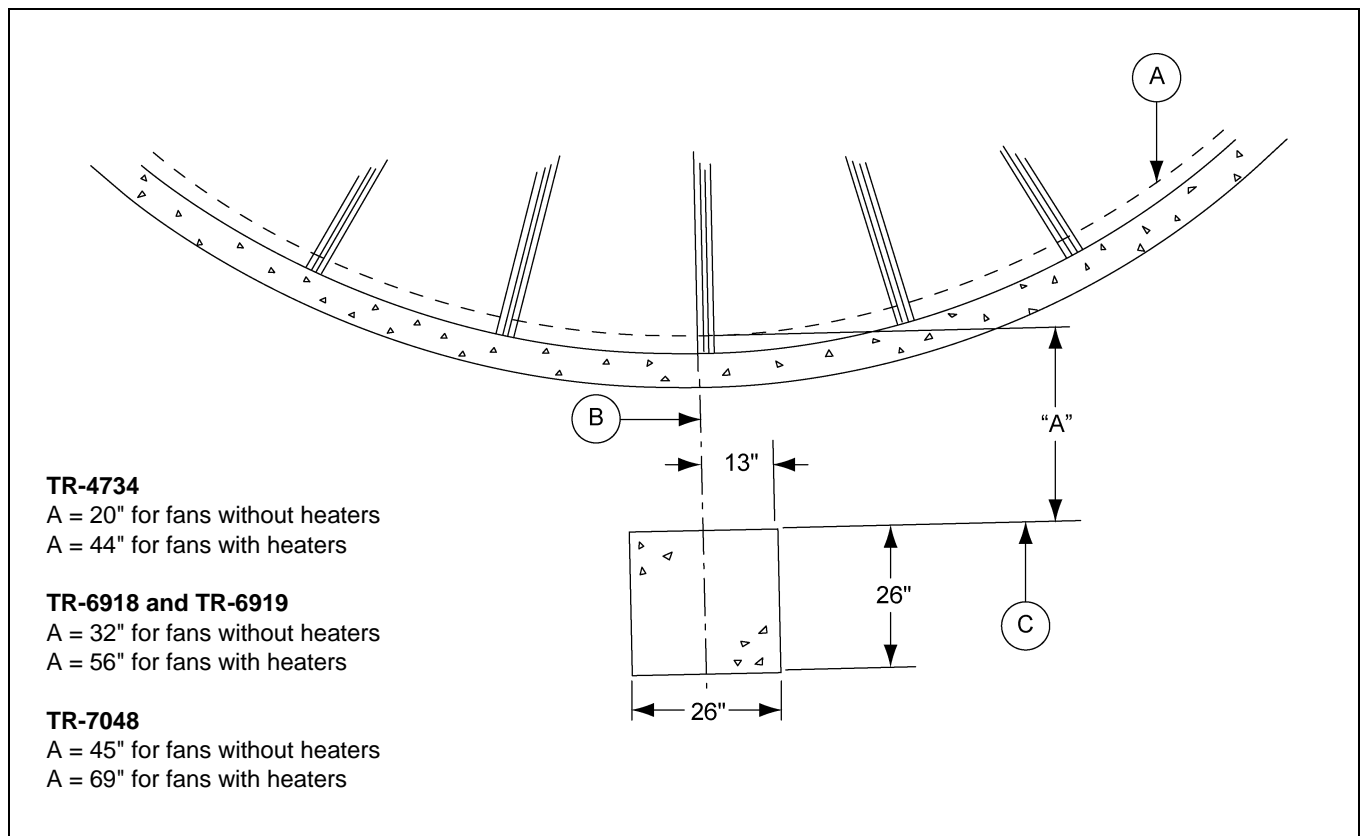

Figure 1C

Ref #	Description
A	Bin Wall
B	Centerline of Bin
C	From Sidewall

1. General Overview

Centrifugal Fan Pad

1. Fan pad should be poured 2" below the top of the bin foundation for all centrifugal fans.
2. A pad for heaters is not required, but is recommended.
3. Recommended pad thickness is 4".
4. If a downwind heater pad is to be installed, the pad width ("C") should be 48" and extended toward the bin by 33".
5. Fan discharge should be centered on centerline of bin.
6. The fan pad should be perpendicular to bin wall.



Fan pad and fan must be level and smooth for proper operation. Vibration problems can result from improper fan leveling.

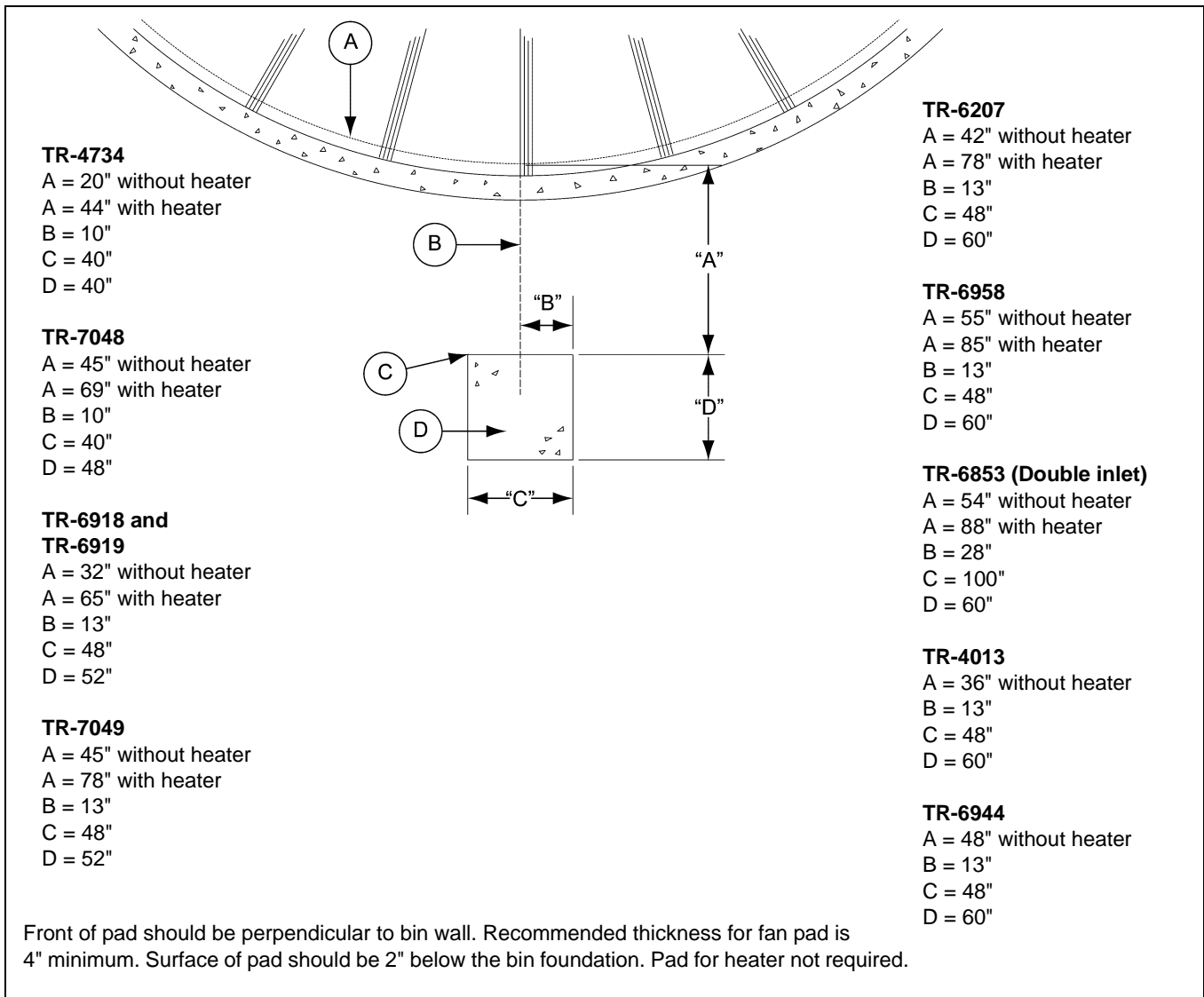

Figure 1D Centrifugal Fan Pad

Ref #	Description	Ref #	Description
A	Bin Wall	C	Dimension From Sidewall
B	Centerline of Bin	D	Fan Pad

66' Diameter, 12-24 Ring (2.66" Corrugation), 3000 PSF Allowable Soil Bearing Capacity

1. The foundation design is based on a minimum allowable soil bearing capacity of 3000 lbs./ft². Bearing capacity of the soils should be determined by geotechnical investigation and be of uniform bearing capacity.
2. The foundation site must be free of vegetation and debris and well drained.
3. The foundation must be founded below the frost line or constructed on non-expansive frost free fill.
4. All material used for backfill inside the ring wall should be clean, well graded, crushed rock or a sand-gravel mixture. Backfill should be placed in 6" lifts, 95% compaction.
5. All reinforcement must meet the requirements of ASTM A615 grade 60 deformed bars.
6. Lap all circumferential bars 40 bar diameters and stagger all laps in plans 3'-0". Estimates do not include end laps.
7. Concrete must have a minimum compressive strength of 4500 PSI at 28 days.
8. Foundation recommendation charts are provided as an aid in material estimation purposes for standard commercial bin design conditions. Seismic conditions are not considered.

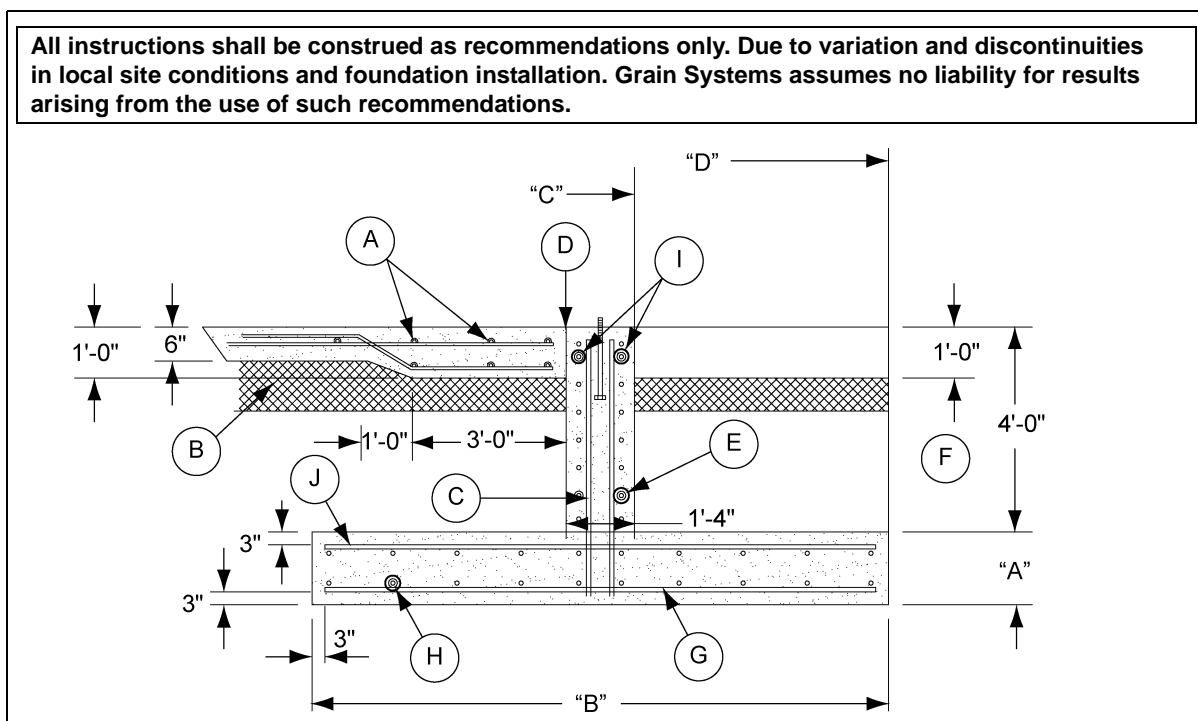

Figure 2A 66' Bin (12-24 Ring)

Ref #	Description	Ref #	Description
A	# 4 Bars @ 18" C/C Each Way	F	Grade
B	Well Compacted Fill	G	"P" Bars Spacing at Center of Footing
C	# 5 Bars @ 18" C/C Each Face (W STD 90° Hook)	H	"N" Bars Evenly Spaced
D	1/2" Expansion Joint	I	Two (2) Additional Hoop Bars, 3" from Top Hoop Bars
E	"M" Bars Evenly Spaced Each Face	J	"Q" Bars Spacing at Center of Footing

2. Inverted "T" Foundation

Diameter of Bin: 66'

Soil Bearing Capacity: 3000 PSF

	Ring #	12	14	16	18
	A	1'-0"	1'-0"	1'-0"	1'-0"
	B	3'-6"	4'-0"	5'-0"	6'-0"
	C	33'-10"	33'-10"	33'-10"	33'-10"
	D	34'-10"	35'-1"	35'-6"	35'-11"
	M	7 #5's	7 #5's	7 #5's	7 #5's
	N	4 #5's	5 #5's	6 #5's	7 #5's
	P	#5 @ 12" c/c	#5 @ 12" c/c	#5 @ 12" c/c	#5 @ 12" c/c
	Q	#5 @ 12" c/c	#5 @ 12" c/c	#5 @ 12" c/c	#5 @ 12" c/c
Rerod	#4 (ft.)	5300	5300	5300	5300
	#5 (ft.)	5300	5800	6400	7000
	#6 (ft.)	0	0	0	0
Weight (Lbs.)		9000	9550	10200	10825
Cu. Yds. Concrete	Footing	27	31	38	46
	Wall	42	42	42	42
	Floor	73	73	73	73
	Total	142	146	153	161

	Ring #	20	22	24
	A	1'-2"	1'-3"	1'-4"
	B	7'-6"	8'-6"	10'-0"
	C	33'-10"	33'-10"	33'-10"
	D	36'-7"	37'-0"	37'-7"
	M	7 #5's	7 #5's	8 #5's
	N	8 #5's	11 #5's	13 #5's
	P	#5 @ 12" c/c	#5 @ 10" c/c	#6 @ 10" c/c
	Q	#5 @ 12" c/c	#5 @ 12" c/c	#5 @ 12" c/c
Rerod	#4 (ft.)	5300	5300	5300
	#5 (ft.)	7700	9500	8700
	#6 (ft.)	0	0	2400
Weight (Lbs.)		11575	13400	16225
Cu. Yds. Concrete	Footing	67	81	101
	Wall	42	42	42
	Floor	73	73	73
	Total	182	196	216

66' Diameter, 12-24 Ring (2.66" Corrugation), 3500 PSF Allowable Soil Bearing Capacity

1. The foundation design is based on a minimum allowable soil bearing capacity of 3500 lbs./ft². Bearing capacity of the soils should be determined by geotechnical investigation and be of uniform bearing capacity.
2. The foundation site must be free of vegetation and debris and well drained.
3. The foundation must be founded below the frost line or constructed on non-expansive frost free fill.
4. All material used for backfill inside the ring wall should be clean, well graded, crushed rock or a sand-gravel mixture. Backfill should be placed in 6" lifts, 95% compaction.
5. All reinforcement must meet the requirements of ASTM A615 grade 60 deformed bars.
6. Lap all circumferential bars 40 bar diameters and stagger all laps in plans 3'-0". Estimates do not include end laps.
7. Concrete must have a minimum compressive strength of 4500 PSI at 28 days.
8. Foundation recommendation charts are provided as an aid in material estimation purposes for standard commercial bin design conditions. Seismic conditions are not considered.

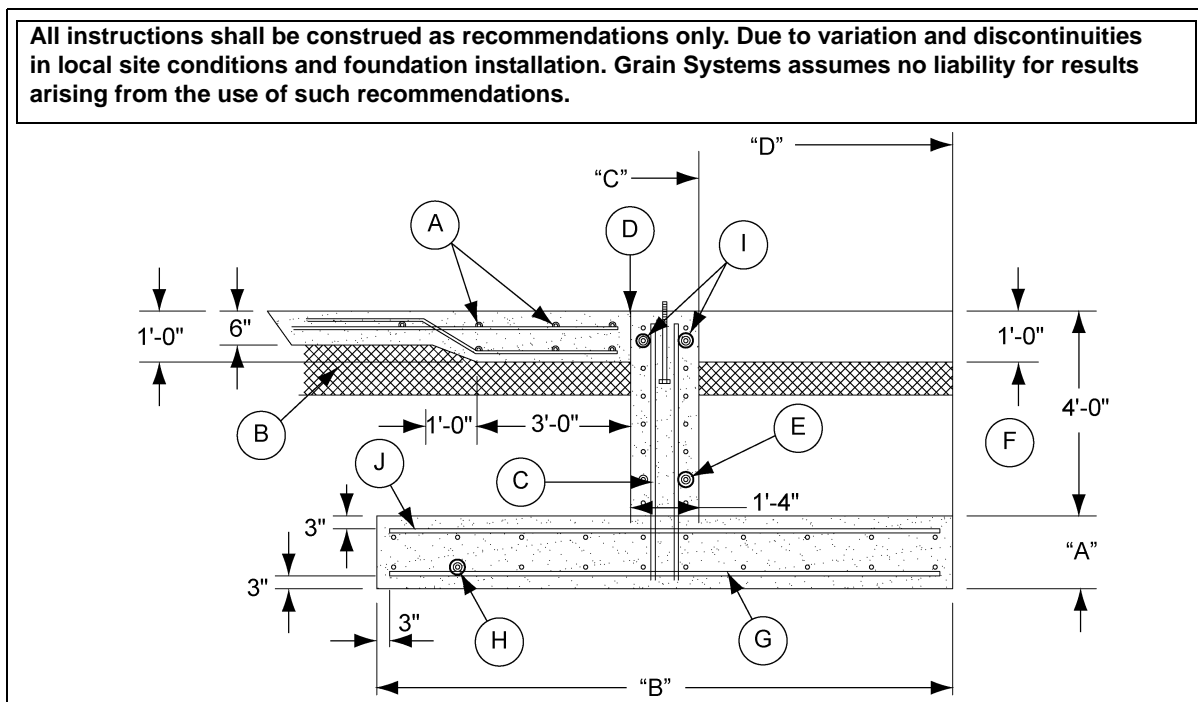

Figure 2B 66' Bin (12-24 Ring)

Ref #	Description	Ref #	Description
A	# 4 Bars @ 18" C/C Each Way	F	Grade
B	Well Compacted Fill	G	"P" Bars Spacing at Center of Footing
C	# 5 Bars @ 18" C/C Each Face (W STD 90° Hook)	H	"N" Bars Evenly Spaced
D	1/2" Expansion Joint	I	Two (2) Additional Hoop Bars, 3" from Top Hoop Bars
E	"M" Bars Evenly Spaced Each Face	J	"Q" Bars Spacing at Center of Footing

2. Inverted "T" Foundation

Diameter of Bin: 66'
Soil Bearing Capacity: 3500 PSF

	Ring #	12	14	16	18
	A	1'-0"	1'-0"	1'-0"	1'-0"
	B	3'-0"	3'-3"	4'-3"	5'-3"
	C	33'-10"	33'-10"	33'-10"	33'-10"
	D	34'-7"	34'-9"	35'-2"	35'-7"
	M	7 #5's	7 #5's	7 #5's	7 #5's
	N	4 #5's	4 #5's	5 #5's	6 #5's
	P	#5 @ 12" c/c	#5 @ 12" c/c	#5 @ 12" c/c	#5 @ 12" c/c
	Q	#5 @ 12" c/c	#5 @ 12" c/c	#5 @ 12" c/c	#5 @ 12" c/c
Rerod	#4 (ft.)	5300	5300	5300	5300
	#5 (ft.)	5200	5200	5800	6500
	#6 (ft.)	0	0	0	0
Weight (Lbs.)		8900	8950	9600	10225
Cu. Yds. Concrete	Footing	23	25	32	40
	Wall	42	42	42	42
	Floor	73	73	73	73
	Total	138	140	147	155

	Ring #	20	22	24
	A	1'-2"	1'-3"	1'-3"
	B	6'-6"	7'-6"	8'-0"
	C	33'-10"	33'-10"	33'-10"
	D	36'-1"	36'-6"	36'-9"
	M	7 #5's	7 #5's	8 #5's
	N	8 #5's	8 #5's	9 #5's
	P	#5 @ 12" c/c	#5 @ 12" c/c	#6 @ 12" c/c
	Q	#5 @ 12" c/c	#5 @ 12" c/c	#5 @ 12" c/c
Rerod	#4 (ft.)	5300	5300	5300
	#5 (ft.)	7500	7700	7100
	#6 (ft.)	0	0	1600
Weight (Lbs.)		11350	11550	13325
Cu. Yds. Concrete	Footing	58	71	76
	Wall	42	42	42
	Floor	73	73	73
	Total	173	186	191

66' Diameter, 26-27 Ring (2.66" Corrugation), 3500 PSF Allowable Soil Bearing Capacity

1. The foundation design is based on a minimum allowable soil bearing capacity of 3500 lbs./ft². Bearing capacity of the soils should be determined by geotechnical investigation and be of uniform bearing capacity.
2. The foundation site must be free of vegetation and debris and well drained.
3. The foundation must be founded below the frost line or constructed on non-expansive frost free fill.
4. All material used for backfill inside the ring wall should be clean, well graded, crushed rock or a sand-gravel mixture. Backfill should be placed in 6" lifts, 95% compaction.
5. All reinforcement must meet the requirements of ASTM A615 grade 60 deformed bars.
6. Lap all circumferential bars 40 bar diameters and stagger all laps in plans 3'-0". Estimates do not include end laps.
7. Concrete must have a minimum compressive strength of 4500 PSI at 28 days.
8. Foundation recommendation charts are provided as an aid in material estimation purposes for standard commercial bin design conditions. Seismic conditions are not considered.

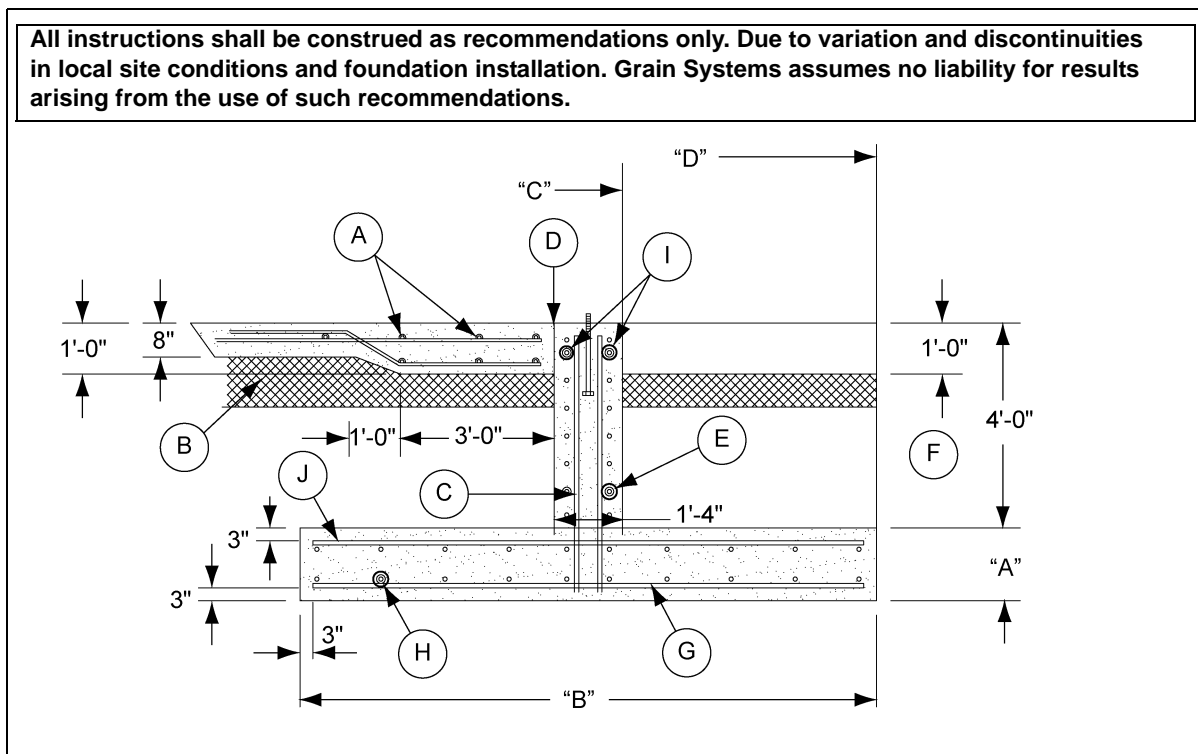

Figure 2C 66' Bin (26-27 Ring)

Ref #	Description
A	# 5 Bars @ 18" C/C Each Way
B	Well Compacted Fill
C	# 5 Bars @ 18" C/C Each Face (W STD 90° Hook)
D	1/2" Expansion Joint
E	"M" Bars Evenly Spaced Each Face

Ref #	Description
F	Grade
G	"P" Bars Spacing at Center of Footing
H	"N" Bars Evenly Spaced
I	Two (2) Additional Hoop Bars, 3" from Top Hoop Bars
J	"Q" Bars Spacing at Center of Footing

2. Inverted "T" Foundation

Diameter of Bin: 66'
Soil Bearing Capacity: 3500 PSF

	Ring #	26	27
	A	1'-4"	1'-4"
	B	10'-0"	10'-6"
	C	33'-10"	33'-10"
	D	37'-7"	37'-10"
	M	8 #5's	8 #5's
	N	11 #5's	11 #5's
	P	#6 @ 9" c/c	#6 @ 9" c/c
	Q	#5 @ 12" c/c	#5 @ 12" c/c
Rerod	#4 (ft.)	0	0
	#5 (ft.)	13100	13100
	#6 (ft.)	2600	2800
Weight (Lbs.)		17550	17850
Cu. Yds. Concrete	Footing	101	106
	Wall	42	42
	Floor	90	90
	Total	233	238

66' Diameter, 12-24 Ring (2.66" Corrugation), 4000 PSF Allowable Soil Bearing Capacity

1. The foundation design is based on a minimum allowable soil bearing capacity of 4000 lbs./ft². Bearing capacity of the soils should be determined by geotechnical investigation and be of uniform bearing capacity.
2. The foundation site must be free of vegetation and debris and well drained.
3. The foundation must be founded below the frost line or constructed on non-expansive frost free fill.
4. All material used for backfill inside the ring wall should be clean, well graded, crushed rock or a sand-gravel mixture. Backfill should be placed in 6" lifts, 95% compaction.
5. All reinforcement must meet the requirements of ASTM A615 grade 60 deformed bars.
6. Lap all circumferential bars 40 bar diameters and stagger all laps in plans 3'-0". Estimates do not include end laps.
7. Concrete must have a minimum compressive strength of 4500 PSI at 28 days.
8. Foundation recommendation charts are provided as an aid in material estimation purposes for standard commercial bin design conditions. Seismic conditions are not considered.

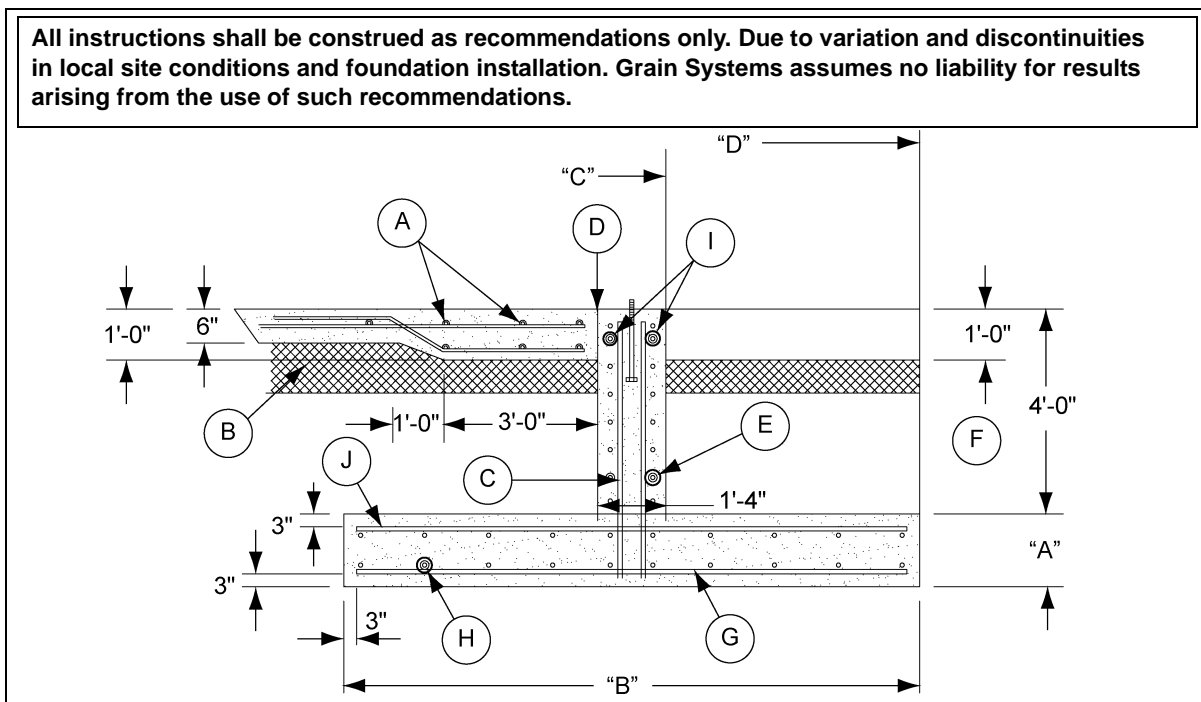

Figure 2D 66' Bin (12-24 Ring)

Ref #	Description	Ref #	Description
A	# 4 Bars @ 18" C/C Each Way	F	Grade
B	Well Compacted Fill	G	"P" Bars Spacing at Center of Footing
C	# 5 Bars @ 18" C/C Each Face (W STD 90° Hook)	H	"N" Bars Evenly Spaced
D	1/2" Expansion Joint	I	Two (2) Additional Hoop Bars, 3" from Top Hoop Bars
E	"M" Bars Evenly Spaced Each Face	J	"Q" Bars Spacing at Center of Footing

2. Inverted "T" Foundation

Diameter of Bin: 66'
Soil Bearing Capacity: 4000 PSF

	Ring #	12	14	16	18
	A	1'-0"	1'-0"	1'-0"	1'-0"
	B	2'-6"	3'-0"	3'-6"	4'-6"
	C	33'-10"	33'-10"	33'-10"	33'-10"
	D	34'-5"	34'-7"	34'-10"	35'-3"
	M	7 #5's	7 #5's	7 #5's	7 #5's
	N	3 #5's	4 #5's	4 #5's	6 #5's
	P	#5 @ 12" c/c	#5 @ 12" c/c	#5 @ 12" c/c	#5 @ 12" c/c
	Q	#5 @ 12" c/c	#5 @ 12" c/c	#5 @ 12" c/c	#5 @ 12" c/c
Rerod	#4 (ft.)	5300	5300	5300	5300
	#5 (ft.)	4700	5200	5300	6300
	#6 (ft.)	0	0	0	0
Weight (Lbs.)		8350	8900	9000	10075
Cu. Yds. Concrete	Footing	19	23	27	34
	Wall	42	42	42	42
	Floor	73	73	73	73
	Total	134	138	142	149

	Ring #	20	22	24
	A	1'-0"	1'-3"	1'-4"
	B	5'-6"	6'-0"	8'-0"
	C	33'-10"	33'-10"	33'-10"
	D	35'-9"	35'-11"	37'-7"
	M	7 #5's	7 #5's	8 #5's
	N	6 #5's	7 #5's	9 #5's
	P	#5 @ 12" c/c	#5 @ 12" c/c	#6 @ 10" c/c
	Q	#5 @ 12" c/c	#5 @ 12" c/c	#5 @ 12" c/c
Rerod	#4 (ft.)	5300	5300	5300
	#5 (ft.)	6500	7000	7100
	#6 (ft.)	0	0	1900
Weight (Lbs.)		10300	10825	13750
Cu. Yds. Concrete	Footing	42	57	81
	Wall	42	42	42
	Floor	73	73	73
	Total	157	172	196

66' Diameter, 26-30 Ring (2.66" Corrugation), 4000 PSF Allowable Soil Bearing Capacity

1. The foundation design is based on a minimum allowable soil bearing capacity of 4000 lbs./ft². Bearing capacity of the soils should be determined by geotechnical investigation and be of uniform bearing capacity.
2. The foundation site must be free of vegetation and debris and well drained.
3. The foundation must be founded below the frost line or constructed on non-expansive frost free fill.
4. All material used for backfill inside the ring wall should be clean, well graded, crushed rock or a sand-gravel mixture. Backfill should be placed in 6" lifts, 95% compaction.
5. All reinforcement must meet the requirements of ASTM A615 grade 60 deformed bars.
6. Lap all circumferential bars 40 bar diameters and stagger all laps in plans 3'-0". Estimates do not include end laps.
7. Concrete must have a minimum compressive strength of 4500 PSI at 28 days.
8. Foundation recommendation charts are provided as an aid in material estimation purposes for standard commercial bin design conditions. Seismic conditions are not considered.

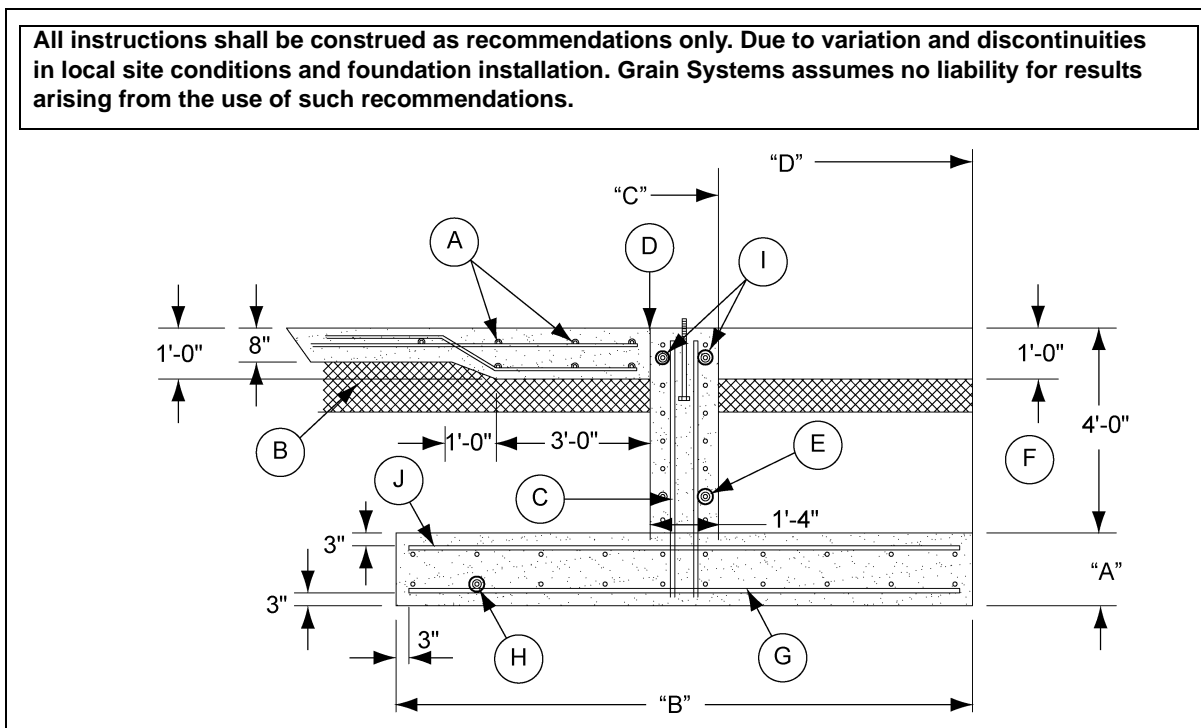

Figure 2E 66' Bin (26-30 Ring)

Ref #	Description	Ref #	Description
A	# 5 Bars @ 18" C/C Each Way	F	Grade
B	Well Compacted Fill	G	"P" Bars Spacing at Center of Footing
C	# 5 Bars @ 18" C/C Each Face (W STD 90° Hook)	H	"N" Bars Evenly Spaced
D	1/2" Expansion Joint	I	Two (2) Additional Hoop Bars, 3" from Top Hoop Bars
E	"M" Bars Evenly Spaced Each Face	J	"Q" Bars Spacing at Center of Footing

2. Inverted "T" Foundation

Diameter of Bin: 66'

Soil Bearing Capacity: 4000 PSF

	Ring #	26	27	28	30
	A	1'-4"	1'-4"	1'-6"	1'-8"
	B	8'-0"	8'-6"	9'-0"	11'-0"
	C	33'-10"	33'-10"	33'-10"	33'-10"
	D	36'-9"	37'-0"	37'-3"	37'-7"
	M	8 #5's	8 #5's	8 #5's	8 #5's
	N	9 #5's	9 #5's	10 #5's	12 #5's
	P	#6 @ 12" c/c	#6 @ 10" c/c	#6 @ 10" c/c	#7 @ 10" c/c
	Q	#5 @ 12" c/c	#5 @ 12" c/c	#5 @ 12" c/c	#5 @ 12" c/c
Rerod	#4 (ft.)	0	0	0	0
	#5 (ft.)	12300	12300	12700	13500
	#6 (ft.)	1600	2000	2100	0
	#7 (ft.)	0	0	0	2600
Weight (Lbs.)		15200	15800	16400	19175
Cu. Yds. Concrete	Footing	81	86	103	137
	Wall	42	42	42	42
	Floor	90	90	90	90
	Total	213	218	235	269

66' Diameter, 32 Ring (2.66" Corrugation), 4500 PSF Allowable Soil Bearing Capacity

1. The foundation design is based on a minimum allowable soil bearing capacity of 4500 lbs./ft². Bearing capacity of the soils should be determined by geotechnical investigation and be of uniform bearing capacity.
2. The foundation site must be free of vegetation and debris and well drained.
3. The foundation must be founded below the frost line or constructed on non-expansive frost free fill.
4. All material used for backfill inside the ring wall should be clean, well graded, crushed rock or a sand-gravel mixture. Backfill should be placed in 6" lifts, 95% compaction.
5. All reinforcement must meet the requirements of ASTM A615 grade 60 deformed bars.
6. Lap all circumferential bars 40 bar diameters and stagger all laps in plans 3'-0". Estimates do not include end laps.
7. Concrete must have a minimum compressive strength of 4500 PSI at 28 days.
8. Foundation recommendation charts are provided as an aid in material estimation purposes for standard commercial bin design conditions. Seismic conditions are not considered.

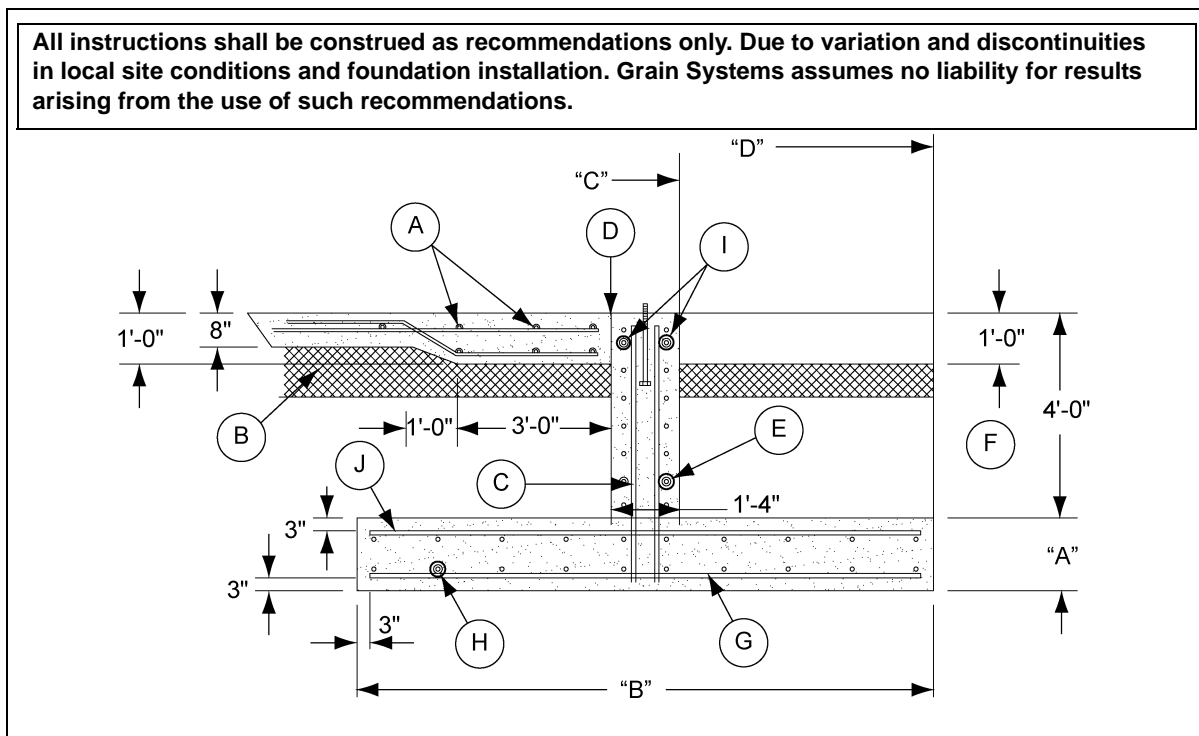

Figure 2F 66' Bin (32 Ring)

Ref #	Description	Ref #	Description
A	# 5 Bars @ 18" C/C Each Way	F	Grade
B	Well Compacted Fill	G	"P" Bars Spacing at Center of Footing
C	# 5 Bars @ 18" C/C Each Face (W STD 90° Hook)	H	"N" Bars Evenly Spaced
D	1/2" Expansion Joint	I	Two (2) Additional Hoop Bars, 3" from Top Hoop Bars
E	"M" Bars Evenly Spaced Each Face	J	"Q" Bars Spacing at Center of Footing

2. Inverted "T" Foundation

Diameter of Bin: 66'
Soil Bearing Capacity: 4500 PSF

	Ring #	32
	A	1'-8"
	B	9'-6"
	C	33'-10"
	D	37'-5"
	M	10 #5's
	N	10 #5's
	P	#7 @ 12" c/c
	Q	#5 @ 12" c/c
Rerod	#4 (ft.)	0
	#5 (ft.)	13600
	#6 (ft.)	0
	#7 (ft.)	1900
Weight (Lbs.)		17900
Cu. Yds. Concrete	Footing	120
	Wall	42
	Floor	90
	Total	252

66' Diameter, 34 Ring (2.66" Corrugation), 5000 PSF Allowable Soil Bearing Capacity

1. The foundation design is based on a minimum allowable soil bearing capacity of 5000 lbs./ft². Bearing capacity of the soils should be determined by geotechnical investigation and be of uniform bearing capacity.
2. The foundation site must be free of vegetation and debris and well drained.
3. The foundation must be founded below the frost line or constructed on non-expansive frost free fill.
4. All material used for backfill inside the ring wall should be clean, well graded, crushed rock or a sand-gravel mixture. Backfill should be placed in 6" lifts, 95% compaction.
5. All reinforcement must meet the requirements of ASTM A615 grade 60 deformed bars.
6. Lap all circumferential bars 40 bar diameters and stagger all laps in plans 3'-0". Estimates do not include end laps.
7. Concrete must have a minimum compressive strength of 4500 PSI at 28 days.
8. Foundation recommendation charts are provided as an aid in material estimation purposes for standard commercial bin design conditions. Seismic conditions are not considered.

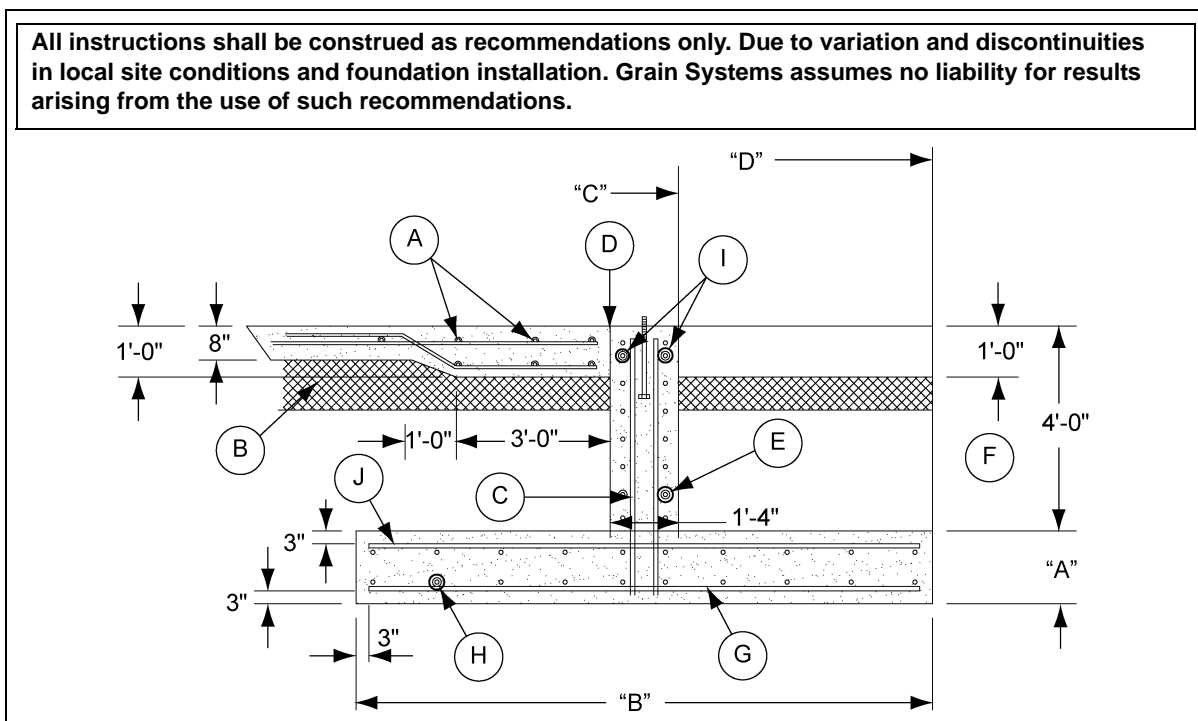

Figure 2G 66' Bin (34 Ring)

Ref #	Description	Ref #	Description
A	# 5 Bars @ 18" C/C Each Way	F	Grade
B	Well Compacted Fill	G	"P" Bars Spacing at Center of Footing
C	# 5 Bars @ 18" C/C Each Face (W STD 90° Hook)	H	"N" Bars Evenly Spaced
D	1/2" Expansion Joint	I	Two (2) Additional Hoop Bars, 3" from Top Hoop Bars
E	"M" Bars Evenly Spaced Each Face	J	"Q" Bars Spacing at Center of Footing

2. Inverted "T" Foundation

Diameter of Bin: 66'
Soil Bearing Capacity: 5000 PSF

	Ring #	34
	A	1'-8"
	B	9'-6"
	C	33'-10"
	D	37'-5"
	M	10 #5's
	N	10 #5's
	P	#7 @ 10" c/c
	Q	#5 @ 12" c/c
Rerod	#4 (ft.)	0
	#5 (ft.)	13600
	#6 (ft.)	0
	#7 (ft.)	2300
Weight (Lbs.)		18650
Cu. Yds. Concrete	Footing	120
	Wall	42
	Floor	90
	Total	252

66' Diameter, 37 Ring (2.66" Corrugation), 5500 PSF Allowable Soil Bearing Capacity

1. The foundation design is based on a minimum allowable soil bearing capacity of 5500 lbs./ft². Bearing capacity of the soils should be determined by geotechnical investigation and be of uniform bearing capacity.
2. The foundation site must be free of vegetation and debris and well drained.
3. The foundation must be founded below the frost line or constructed on non-expansive frost free fill.
4. All material used for backfill inside the ring wall should be clean, well graded, crushed rock or a sand-gravel mixture. Backfill should be placed in 6" lifts, 95% compaction.
5. All reinforcement must meet the requirements of ASTM A615 grade 60 deformed bars.
6. Lap all circumferential bars 40 bar diameters and stagger all laps in plans 3'-0". Estimates do not include end laps.
7. Concrete must have a minimum compressive strength of 4500 PSI at 28 days.
8. Foundation recommendation charts are provided as an aid in material estimation purposes for standard commercial bin design conditions. Seismic conditions are not considered.

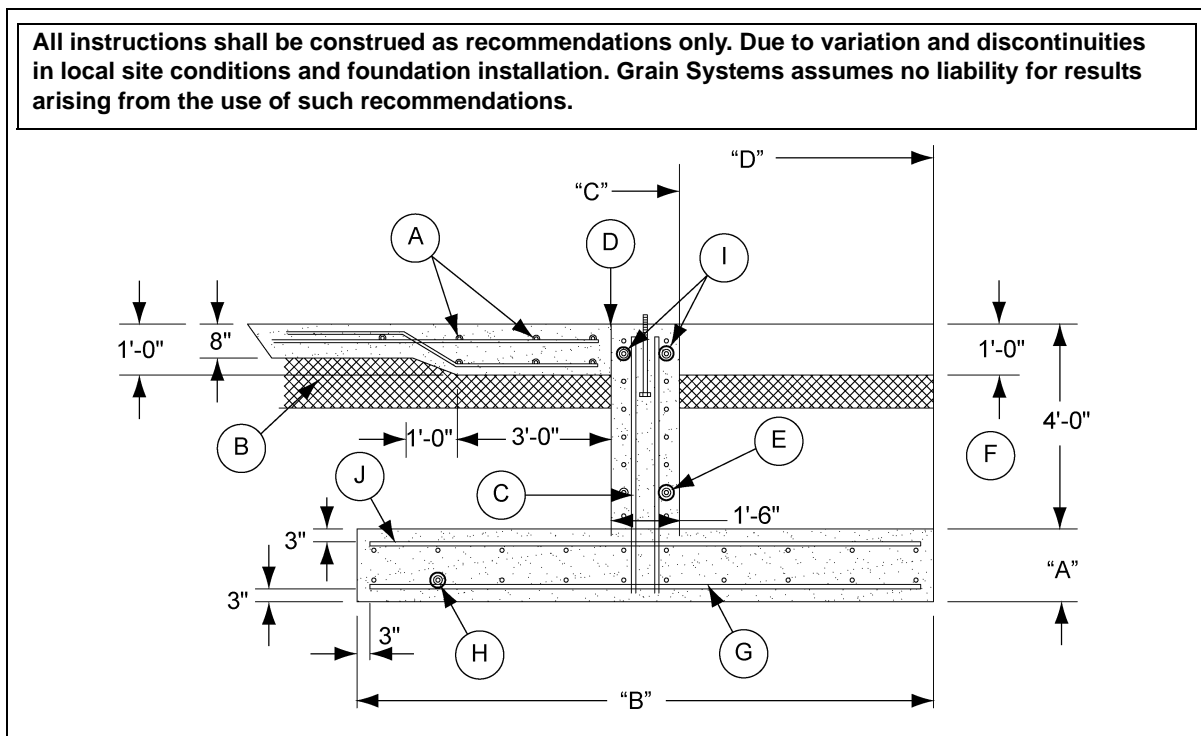

Figure 2H 66' Bin (37 Ring)

Ref #	Description	Ref #	Description
A	# 5 Bars @ 18" C/C Each Way	F	Grade
B	Well Compacted Fill	G	"P" Bars Spacing at Center of Footing
C	# 5 Bars @ 18" C/C Each Face (W STD 90° Hook)	H	"N" Bars Evenly Spaced
D	1/2" Expansion Joint	I	Two (2) Additional Hoop Bars, 3" from Top Hoop Bars
E	"M" Bars Evenly Spaced Each Face	J	"Q" Bars Spacing at Center of Footing

2. Inverted "T" Foundation

Diameter of Bin: 66'
Soil Bearing Capacity: 5500 PSF

	Ring #	37
	A	1'-8"
	B	9'-6"
	C	33'-11"
	D	37'-7"
	M	10 #5's
	N	10 #5's
	P	#8 @ 12" c/c
	Q	#5 @ 12" c/c
Rerod	#4 (ft.)	0
	#5 (ft.)	13600
	#6 (ft.)	0
	#7 (ft.)	0
	#8 (ft.)	1900
Weight (Lbs.)		19175
Cu. Yds. Concrete	Footing	121
	Wall	46
	Floor	90
	Total	257

66' Diameter, 40 Ring (2.66" Corrugation), 6000 PSF Allowable Soil Bearing Capacity

1. The foundation design is based on a minimum allowable soil bearing capacity listed on the chart. Bearing capacity of the soils should be determined by geotechnical investigation and be of uniform bearing capacity.
2. The foundation site must be free of vegetation and debris and well drained.
3. The foundation must be founded below the frost line or constructed on non-expansive frost free fill.
4. All material used for backfill inside the ring wall should be clean, well graded, crushed rock or a sand-gravel mixture. Backfill should be placed in 6" lifts, 95% compaction.
5. All reinforcement must meet the requirements of ASTM A615 grade 60 deformed bars.
6. Lap all circumferential bars 40 bar diameters and stagger all laps in plans 3'-0". Estimates do not include end laps.
7. Concrete must have a minimum compressive strength of 4500 PSI at 28 days.
8. Foundation recommendation charts are provided as an aid in material estimation purposes for standard commercial bin design conditions. Seismic conditions are not considered.

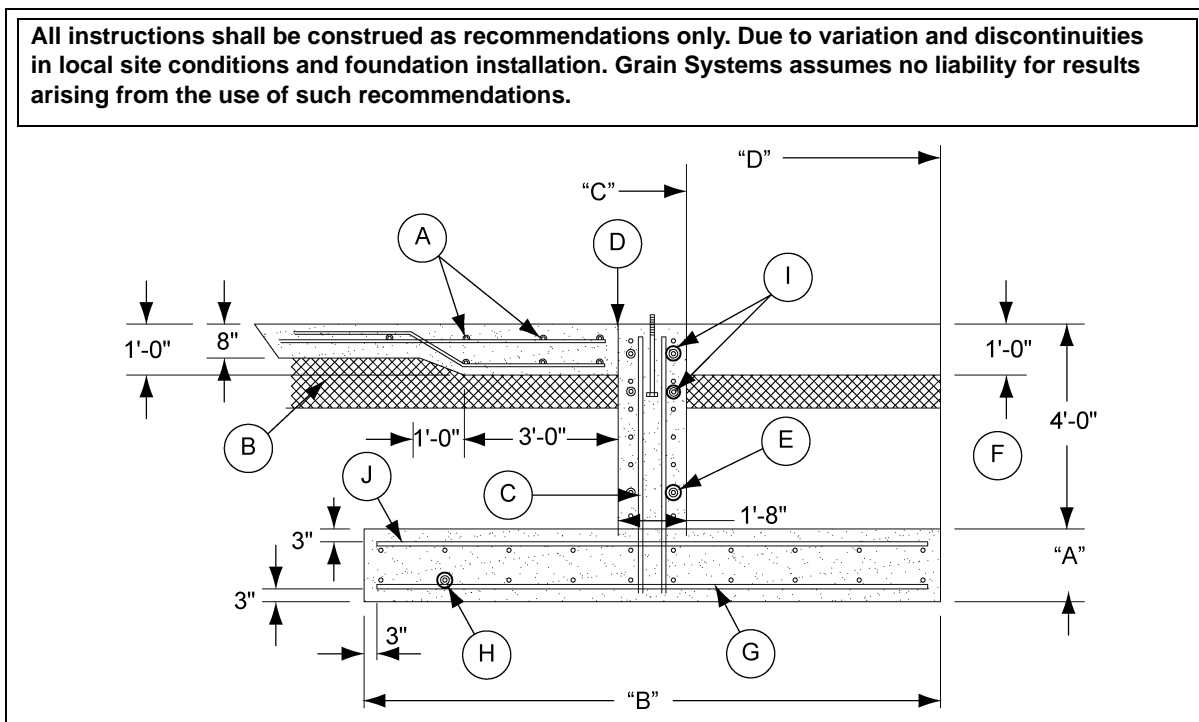

Figure 2I 66' Bin (40 Ring)

Ref #	Description	Ref #	Description
A	# 5 Bars @ 18" C/C Each Way	F	Grade
B	Well Compacted Fill	G	"P" Bars Spacing at Center of Footing
C	# 5 Bars @ 18" C/C Each Face (W STD 90° Hook)	H	"N" Bars Evenly Spaced
D	1/2" Expansion Joint	I	Two (2) Additional Hoop Bars Each Face, 3" from Top Hoop Bars. Maintain a Minimum of 3" Between Hoop Bars.
E	"M" Bars Evenly Spaced Each Face	J	"Q" Bars Spacing at Center of Footing

2. Inverted "T" Foundation

Diameter of Bin: 66'
Soil Bearing Capacity: 6000 PSF

	Ring #	40
	A	1'-10"
	B	9'-6"
	C	34'-0"
	D	37'-7"
	M	11 #5's
	N	10 #5's
	P	#8 @ 12" c/c
	Q	#5 @ 12" c/c
Rerod	#5 (ft.)	13900
	#6 (ft.)	0
	#7 (ft.)	0
	#8 (ft.)	1900
Weight (Lbs.)		19575
Total Cu. Yds. of Concrete	Footing	133
	Wall	52
	Floor	89
	Total	274

66' Diameter, 12-24 Ring (2.66" Corrugation) Frost Free Pad, 3000 PSF Allowable Soil Bearing Capacity

1. The foundation design is based on a minimum allowable soil bearing capacity of 3000 lbs./ft². Bearing capacity of the soils should be determined by geotechnical investigation and be of uniform bearing capacity.
2. The foundation site must be free of vegetation and debris and well drained.
3. The foundation must be founded below the frost line or constructed on non-expansive frost free fill.
4. All material used for backfill inside the ring wall should be clean, well graded, crushed rock or a sand-gravel mixture. Backfill should be placed in 6" lifts, 95% compaction.
5. All reinforcement must meet the requirements of ASTM A615 grade 60 deformed bars.
6. Lap all circumferential bars 40 bar diameters and stagger all laps in plans 3'-0". Estimates do not include end laps.
7. Concrete must have a minimum compressive strength of 4500 PSI at 28 days.
8. The full footing thickness is to be maintained and not interrupted.
9. Foundation recommendation charts are provided as an aid in material estimation purposes for standard commercial bin design conditions. Seismic conditions are not considered.

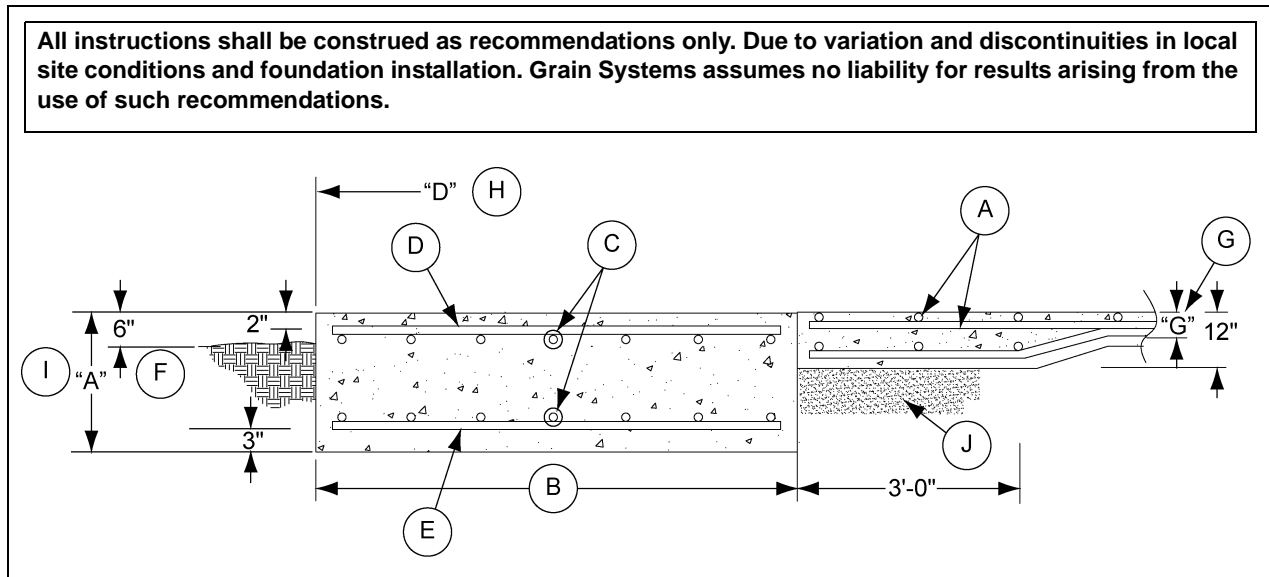

Figure 3A 66' Bin (12-24 Ring)

Ref #	Description
A	# 4 Bars @ 18" Each Direction
B	Footing Width
C	"N" Bars Each Face
D	"Q" Bars
E	"P" Bars

Ref #	Description
F	Grade
G	Slab Thickness "G"
H	Outside Footing Radius "D"
I	Footing Thickness "A"
J	Well Compacted Fill

3. Frost Free Pad Foundation

Diameter of Bin: 66'
Soil Bearing Capacity: 3000 PSF

	Ring #	12	14	16	18
	A	1'-6"	1'-6"	1'-6"	1'-6"
	B	3'-0"	4'-0"	5'-0"	5'-6"
	D	34'-6"	35'-0"	35'-5"	35'-7"
	G	6"	6"	6"	6"
	N	4 #5's	5 #5's	6 #5's	6 #5's
	P	#6 @ 12" c/c	#6 @ 12" c/c	#6 @ 12" c/c	#6 @ 12" c/c
	Q	#5 @ 12" c/c	#5 @ 12" c/c	#5 @ 12" c/c	#5 @ 12" c/c
Rerod	#4 (ft.)	4900	4800	4600	4500
	#5 (ft.)	3900	4900	5900	6000
	#6 (ft.)	600	800	1000	1100
	#7 (ft.)	0	0	0	0
Weight (Lbs.)		8250	9525	10750	10925
Total Cu. Yds. of Concrete	Total	103	113	122	126

	Ring #	20	22	24
	A	1'-6"	1'-6"	1'-6"
	B	7'-0"	8'-0"	10'-0"
	D	36'-2"	36'-7"	37'-5"
	G	6"	6"	6"
	N	8 #5's	9 #5's	11 #5's
	P	#6 @ 12" c/c	#6 @ 12" c/c	#7 @ 12" c/c
	Q	#5 @ 12" c/c	#5 @ 12" c/c	#5 @ 12" c/c
Rerod	#4 (ft.)	4300	4100	3800
	#5 (ft.)	7900	8900	10900
	#6 (ft.)	1400	1600	0
	#7 (ft.)	0	0	2000
Weight (Lbs.)		13225	14425	18000
Total Cu. Yds. of Concrete	Total	139	148	166

66' Diameter, 12-24 Ring (2.66" Corrugation) Frost Free Pad, 3500 PSF Allowable Soil Bearing Capacity

1. The foundation design is based on a minimum allowable soil bearing capacity of 3500 lbs./ft². Bearing capacity of the soils should be determined by geotechnical investigation and be of uniform bearing capacity.
2. The foundation site must be free of vegetation and debris and well drained.
3. The foundation must be founded below the frost line or constructed on non-expansive frost free fill.
4. All material used for backfill inside the ring wall should be clean, well graded, crushed rock or a sand-gravel mixture. Backfill should be placed in 6" lifts, 95% compaction.
5. All reinforcement must meet the requirements of ASTM A615 grade 60 deformed bars.
6. Lap all circumferential bars 40 bar diameters and stagger all laps in plans 3'-0". Estimates do not include end laps.
7. Concrete must have a minimum compressive strength of 4500 PSI at 28 days.
8. The full footing thickness is to be maintained and not interrupted.
9. Foundation recommendation charts are provided as an aid in material estimation purposes for standard commercial bin design conditions. Seismic conditions are not considered.

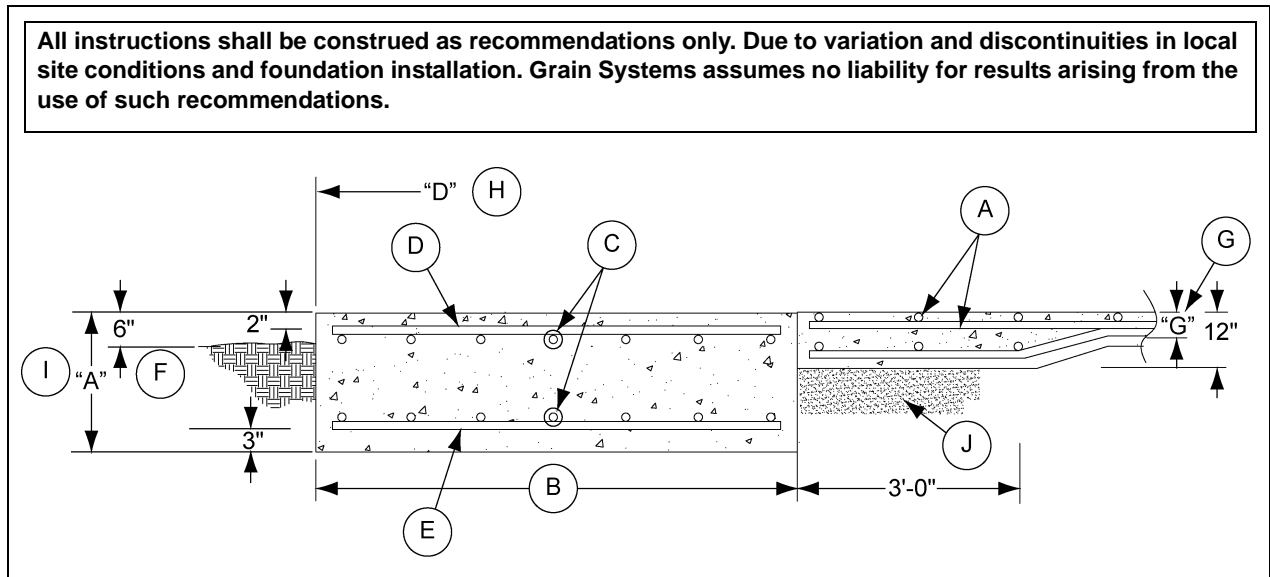

Figure 3B 66' Bin (12-24 Ring)

Ref #	Description
A	# 4 Bars @ 18" Each Direction
B	Footing Width
C	"N" Bars Each Face
D	"Q" Bars
E	"P" Bars

Ref #	Description
F	Grade
G	Slab Thickness "G"
H	Outside Footing Radius "D"
I	Footing Thickness "A"
J	Well Compacted Fill

3. Frost Free Pad Foundation

Diameter of Bin: 66'

Soil Bearing Capacity: 3500 PSF

	Ring #	12	14	16	18
	A	1'-6"	1'-6"	1'-6"	1'-6"
	B	2'-6"	3'-3"	3'-9"	4'-9"
	D	34'-4"	34'-8"	34'-11"	35'-4"
	G	6"	6"	6"	6"
	N	3 #5's	4 #5's	5 #5's	6 #5's
	P	#6 @ 12" c/c	#6 @ 12" c/c	#6 @ 12" c/c	#6 @ 12" c/c
	Q	#5 @ 12" c/c	#5 @ 12" c/c	#5 @ 12" c/c	#5 @ 12" c/c
Rerod	#4 (ft.)	5000	4900	4800	4600
	#5 (ft.)	2900	3900	4800	5900
	#6 (ft.)	500	600	700	900
Weight (Lbs.)		7125	8250	9275	10600
Total Cu. Yds. of Concrete	Total	99	105	110	119

	Ring #	20	22	24
	A	1'-6"	1'-6"	1'-6"
	B	5'-9"	6'-9"	8'-0"
	D	35'-9"	36'-2"	36'-8"
	G	6"	6"	6"
	N	7 #5's	8 #5's	9 #5's
	P	#6 @ 12" c/c	#6 @ 12" c/c	#6 @ 10" c/c
	Q	#5 @ 12" c/c	#5 @ 12" c/c	#5 @ 12" c/c
Rerod	#4 (ft.)	4500	4300	4100
	#5 (ft.)	6900	7900	8900
	#6 (ft.)	1100	1300	1900
Weight (Lbs.)		11875	13075	14875
Total Cu. Yds. of Concrete	Total	128	137	149

66' Diameter, 26 Ring (2.66" Corrugation) Frost Free Pad, 3500 PSF Allowable Soil Bearing Capacity

1. The foundation design is based on a minimum allowable soil bearing capacity of 3500 lbs./ft². Bearing capacity of the soils should be determined by geotechnical investigation and be of uniform bearing capacity.
2. The foundation site must be free of vegetation and debris and well drained.
3. The foundation must be founded below the frost line or constructed on non-expansive frost free fill.
4. All material used for backfill inside the ring wall should be clean, well graded, crushed rock or a sand-gravel mixture. Backfill should be placed in 6" lifts, 95% compaction.
5. All reinforcement must meet the requirements of ASTM A615 grade 60 deformed bars.
6. Lap all circumferential bars 40 bar diameters and stagger all laps in plans 3'-0". Estimates do not include end laps.
7. Concrete must have a minimum compressive strength of 4500 PSI at 28 days.
8. The full footing thickness is to be maintained and not interrupted.
9. Foundation recommendation charts are provided as an aid in material estimation purposes for standard commercial bin design conditions. Seismic conditions are not considered.

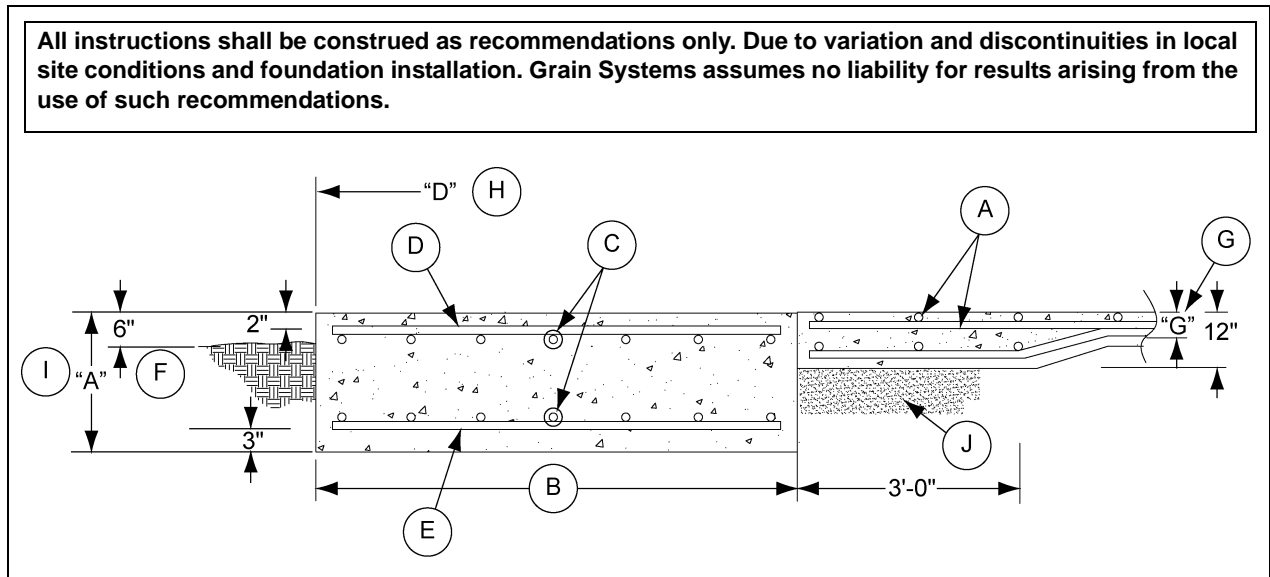

Figure 3C 66' Bin (26 Ring)

Ref #	Description
A	# 5 Bars @ 18" Each Direction
B	Footing Width
C	"N" Bars Each Face
D	"Q" Bars
E	"P" Bars

Ref #	Description
F	Grade
G	Slab Thickness "G"
H	Outside Footing Radius "D"
I	Footing Thickness "A"
J	Well Compacted Fill

3. Frost Free Pad Foundation

Diameter of Bin: 66'
Soil Bearing Capacity: 3500 PSF

	Ring #	26
	A	1'-6"
	B	9'-0"
	D	37'-1"
	G	8"
	N	10 #5's
	P	#7 @ 10" c/c
	Q	#5 @ 12" c/c
Rerod	#4 (ft.)	0
	#5 (ft.)	13900
	#6 (ft.)	0
	#7 (ft.)	2100
Weight (Lbs.)		18800
Total Cu. Yds. of Concrete	Total	169

66' Diameter, 12-24 Ring (2.66" Corrugation) Frost Free Pad, 4000 PSF Allowable Soil Bearing Capacity

1. The foundation design is based on a minimum allowable soil bearing capacity of 4000 lbs./ft². Bearing capacity of the soils should be determined by geotechnical investigation and be of uniform bearing capacity.
2. The foundation site must be free of vegetation and debris and well drained.
3. The foundation must be founded below the frost line or constructed on non-expansive frost free fill.
4. All material used for backfill inside the ring wall should be clean, well graded, crushed rock or a sand-gravel mixture. Backfill should be placed in 6" lifts, 95% compaction.
5. All reinforcement must meet the requirements of ASTM A615 grade 60 deformed bars.
6. Lap all circumferential bars 40 bar diameters and stagger all laps in plans 3'-0". Estimates do not include end laps.
7. Concrete must have a minimum compressive strength of 4500 PSI at 28 days.
8. The full footing thickness is to be maintained and not interrupted.
9. Foundation recommendation charts are provided as an aid in material estimation purposes for standard commercial bin design conditions. Seismic conditions are not considered.

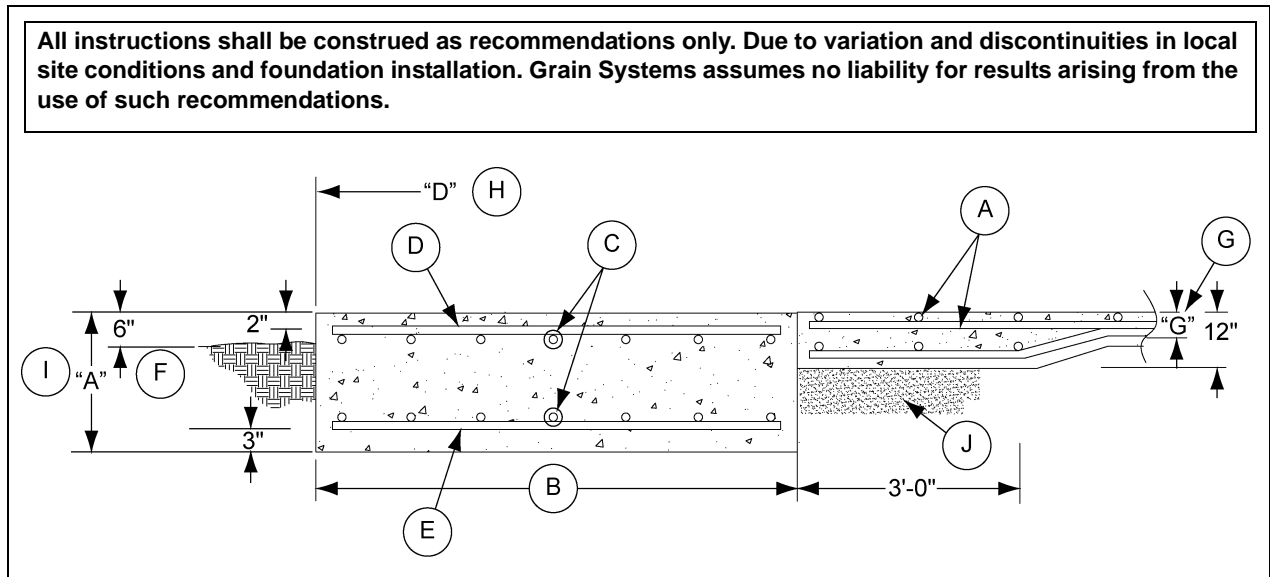

Figure 3D 66' Bin (12-24 Ring)

Ref #	Description
A	# 4 Bars @ 18" Each Direction
B	Footing Width
C	"N" Bars Each Face
D	"Q" Bars
E	"P" Bars

Ref #	Description
F	Grade
G	Slab Thickness "G"
H	Outside Footing Radius "D"
I	Footing Thickness "A"
J	Well Compacted Fill

3. Frost Free Pad Foundation

Diameter of Bin: 66'

Soil Bearing Capacity: 4000 PSF

	Ring #	12	14	16	18
	A	1'-6"	1'-6"	1'-6"	1'-6"
	B	2'-3"	2'-9"	3'-3"	4'-0"
	D	34'-3"	34'-6"	34'-8"	35'-0"
	G	6"	6"	6"	6"
	N	3 #5's	4 #5's	4 #5's	5 #5's
	P	#6 @ 12" c/c	#6 @ 12" c/c	#6 @ 12" c/c	#6 @ 12" c/c
	Q	#5 @ 12" c/c	#5 @ 12" c/c	#5 @ 12" c/c	#5 @ 12" c/c
Rerod	#4 (ft.)	5000	5000	4900	4800
	#5 (ft.)	2900	3800	3900	4900
	#6 (ft.)	400	500	600	800
Weight (Lbs.)		6975	8075	8250	9525
Total Cu. Yds. of Concrete	Total	96	101	105	113

	Ring #	20	22	24
	A	1'-6"	1'-6"	1'-6"
	B	4'-9"	5'-6"	6'-6"
	D	35'-4"	35'-8"	36'-1"
	G	6"	6"	6"
	N	6 #5's	6 #5's	8 #5's
	P	#6 @ 12" c/c	#6 @ 12" c/c	#6 @ 12" c/c
	Q	#5 @ 12" c/c	#5 @ 12" c/c	#5 @ 12" c/c
Rerod	#4 (ft.)	4600	4500	4400
	#5 (ft.)	5900	6000	7900
	#6 (ft.)	900	1100	1300
Weight (Lbs.)		10600	10925	13150
Total Cu. Yds. of Concrete	Total	119	126	135

66' Diameter, 26-28 Ring (2.66" Corrugation) Frost Free Pad, 4000 PSF Allowable Soil Bearing Capacity

1. The foundation design is based on a minimum allowable soil bearing capacity of 4000 lbs./ft². Bearing capacity of the soils should be determined by geotechnical investigation and be of uniform bearing capacity.
2. The foundation site must be free of vegetation and debris and well drained.
3. The foundation must be founded below the frost line or constructed on non-expansive frost free fill.
4. All material used for backfill inside the ring wall should be clean, well graded, crushed rock or a sand-gravel mixture. Backfill should be placed in 6" lifts, 95% compaction.
5. All reinforcement must meet the requirements of ASTM A615 grade 60 deformed bars.
6. Lap all circumferential bars 40 bar diameters and stagger all laps in plans 3'-0". Estimates do not include end laps.
7. Concrete must have a minimum compressive strength of 4500 PSI at 28 days.
8. The full footing thickness is to be maintained and not interrupted.
9. Foundation recommendation charts are provided as an aid in material estimation purposes for standard commercial bin design conditions. Seismic conditions are not considered.

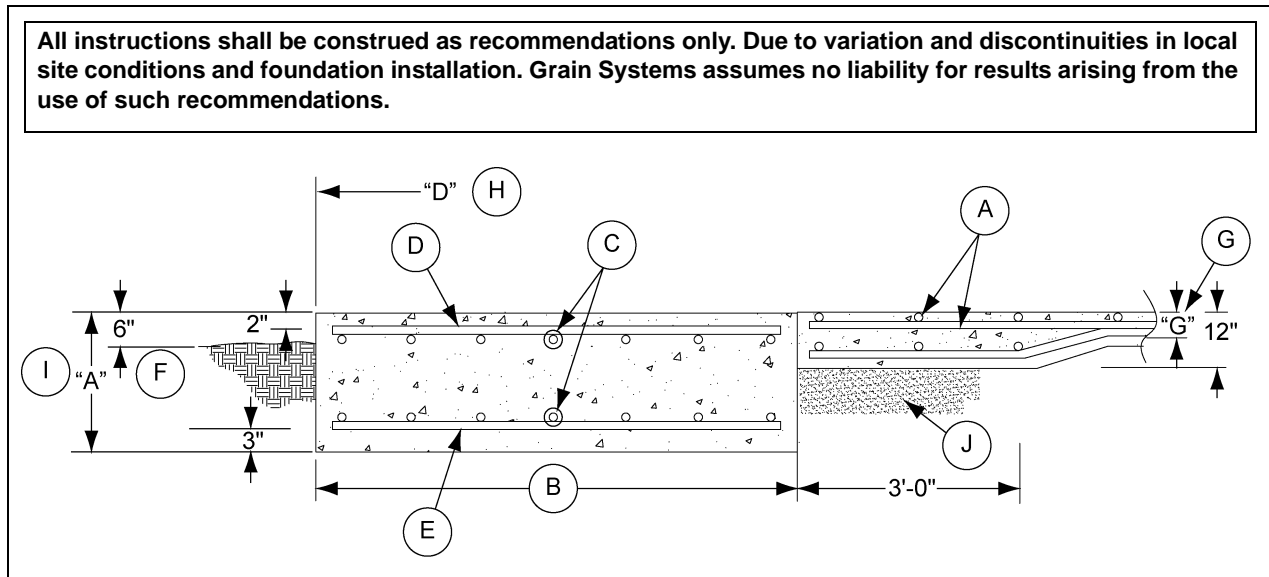

Figure 3E 66' Bin (26-28 Ring)

Ref #	Description
A	# 5 Bars @ 18" Each Direction
B	Footing Width
C	"N" Bars Each Face
D	"Q" Bars
E	"P" Bars

Ref #	Description
F	Grade
G	Slab Thickness "G"
H	Outside Footing Radius "D"
I	Footing Thickness "A"
J	Well Compacted Fill

3. Frost Free Pad Foundation

Diameter of Bin: 66'
Soil Bearing Capacity: 4000 PSF

	Ring #	26	28
	A	1'-6"	1'-6"
	B	7'-6"	8'-6"
	D	36'-6"	36'-11"
	G	8"	8"
	N	8 #5's	9 #5's
	P	#6 @ 10" c/c	#7 @ 10" c/c
	Q	#5 @ 12" c/c	#5 @ 12" c/c
Rerod	#4 (ft.)	0	0
	#5 (ft.)	12200	13100
	#6 (ft.)	1800	0
	#7 (ft.)	0	2000
Weight (Lbs.)		15450	17775
Total Cu. Yds. of Concrete	Total	157	165

GSI Group, LLC Limited Warranty

The GSI Group, LLC ("GSI") warrants products which it manufactures to be free of defects in materials and workmanship under normal usage and conditions for a period of 12 months after sale to the original end-user or if a foreign sale, 14 months from arrival at port of discharge, whichever is earlier. The end-user's sole remedy (and GSI's only obligation) is to repair or replace, at GSI's option and expense, products that in GSI's judgment, contain a material defect in materials or workmanship. Expenses incurred by or on behalf of the end-user without prior written authorization from the GSI Warranty Group shall be the sole responsibility of the end-user.

Warranty Extensions:

The Limited Warranty period is extended for the following products:

	Product	Warranty Period	
AP Fans and Flooring	Performer Series Direct Drive Fan Motor	3 Years	* Warranty prorated from list price: 0 to 3 years - no cost to end-user 3 to 5 years - end-user pays 25% 5 to 7 years - end-user pays 50% 7 to 10 years - end-user pays 75%
	All Fiberglass Housings	Lifetime	
	All Fiberglass Propellers	Lifetime	
AP and Cumberland	Flex-Flo/Pan Feeding System Motors	2 Years	
Cumberland Feeding/Watering Systems	Feeder System Pan Assemblies	5 Years **	** Warranty prorated from list price: 0 to 3 years - no cost to end-user 3 to 5 years - end-user pays 50%
	Feed Tubes (1-3/4" and 2.00")	10 Years *	
	Centerless Augers	10 Years *	
	Watering Nipples	10 Years *	
Grain Systems	Grain Bin Structural Design	5 Years	
Grain Systems Farm Fans Zimmerman	Portable and Tower Dryers	2 Years	† Motors, burner components and moving parts not included. Portable dryer screens included. Tower dryer screens not included.
	Portable and Tower Dryer Frames and Internal Infrastructure †	5 Years	

GSI further warrants that the portable and tower dryer frame and basket, excluding all auger and auger drive components, shall be free from defects in materials for a period of time beginning on the twelfth (12th) month from the date of purchase and continuing until the sixtieth (60th) month from the date of purchase (extended warranty period). During the extended warranty period, GSI will replace the frame or basket components that prove to be defective under normal conditions of use without charge, excluding the labor, transportation and/or shipping costs incurred in the performance of this extended warranty.

Conditions and Limitations:

THERE ARE NO WARRANTIES THAT EXTEND BEYOND THE LIMITED WARRANTY DESCRIPTION SET FORTH ABOVE. SPECIFICALLY, GSI MAKES NO FURTHER WARRANTY OF ANY KIND, EXPRESS OR IMPLIED, INCLUDING, WITHOUT LIMITATION, WARRANTIES OF MERCHANTABILITY OR FITNESS FOR A PARTICULAR PURPOSE OR USE IN CONNECTION WITH: (I) PRODUCT MANUFACTURED OR SOLD BY GSI OR (II) ANY ADVICE, INSTRUCTION, RECOMMENDATION OR SUGGESTION PROVIDED BY AN AGENT, REPRESENTATIVE OR EMPLOYEE OF GSI REGARDING OR RELATED TO THE CONFIGURATION, INSTALLATION, LAYOUT, SUITABILITY FOR A PARTICULAR PURPOSE, OR DESIGN OF SUCH PRODUCTS.

GSI shall not be liable for any direct, indirect, incidental or consequential damages, including, without limitation, loss of anticipated profits or benefits. The sole and exclusive remedy is set forth in the Limited Warranty, which shall not exceed the amount paid for the product purchased. This warranty is not transferable and applies only to the original end-user. GSI shall have no obligation or responsibility for any representations or warranties made by or on behalf of any dealer, agent or distributor.

GSI assumes no responsibility for claims resulting from construction defects or unauthorized modifications to products which it manufactured. Modifications to products not specifically delineated in the manual accompanying the equipment at initial sale will void the Limited Warranty.

This Limited Warranty shall not extend to products or parts which have been damaged by negligent use, misuse, alteration, accident or which have been improperly/inadequately maintained. This Limited Warranty extends solely to products manufactured by GSI.

Prior to installation, the end-user has the responsibility to comply with federal, state and local codes which apply to the location and installation of products manufactured or sold by GSI.

This equipment shall be installed in accordance with the current installation codes and applicable regulations, which should be carefully followed in all cases. Authorities having jurisdiction should be consulted before installations are made.



**1004 E. Illinois St.
Assumption, IL 62510-0020
Phone: 1-217-226-4421
Fax: 1-217-226-4420
www.gsiag.com**



GSI is a worldwide brand of AGCO Corporation.