

## 12 Gauge Transition & Duct Assembly

### TR-4013 Inventory Parts

- 1-PNEG-048 Instructions
- 1-TR-4017 Hardware Package
- 2-CH-6873 Silicone Sealant

### TR-4011 Transition Assembly

- 1-TR-4007 Transition Top Panel
- 1-TR-4008 Transition Bottom Panel
- 2-TR-4009 Transition Side Panels
- 1-TR-4010 Transition Faceplate

### TR-4012 Duct Assembly

- 2-TR-4004 Duct Top & Bottom Panel
- 2-TR-4005 Duct Side Panel
- 2-TR-4006 Duct Splice
- 3-TR-4016 Corrugated 14 Gauge Supports

---

**Seal all joints to insure  
no air leaks or water  
accumulation**

---

1. Assemble TR-4012 duct by standing one side panel and the top panel on end in an “L” shape. Line up holes and screw together. Stand other side panel on end, line up holes with the edge of bottom panel and fasten as before. Next, line up top assembly and bottom assembly and fasten together. Secure splices in “U” shape as shown.
2. Assemble TR-4011 transition in similar manner as duct, but do not attach top panel.
3. Field cut hole in faceplate to dimensions of the inside of the fan discharge. Drill holes to match bolting pattern of fan discharge.
4. Fasten transition to duct, slipping transition discharge over splices and screwing first the sides and then the bottom.
5. Insert faceplate and screw into the bottom and sides.
6. Place fan in position to be bolted to faceplate. Be sure fan and transition are level and fit flush. If not, shim until fan discharge is flush with faceplate. When flush fit is assured, bolt fan to faceplate with bin bolts (not provided with transition assembly).
7. Place transition top panel in place and secure to sides and faceplate. Fasten to duct.
8. When completed, the fan, transition and duct should be one unit.

# 12 Gauge Transition & Duct Assembly

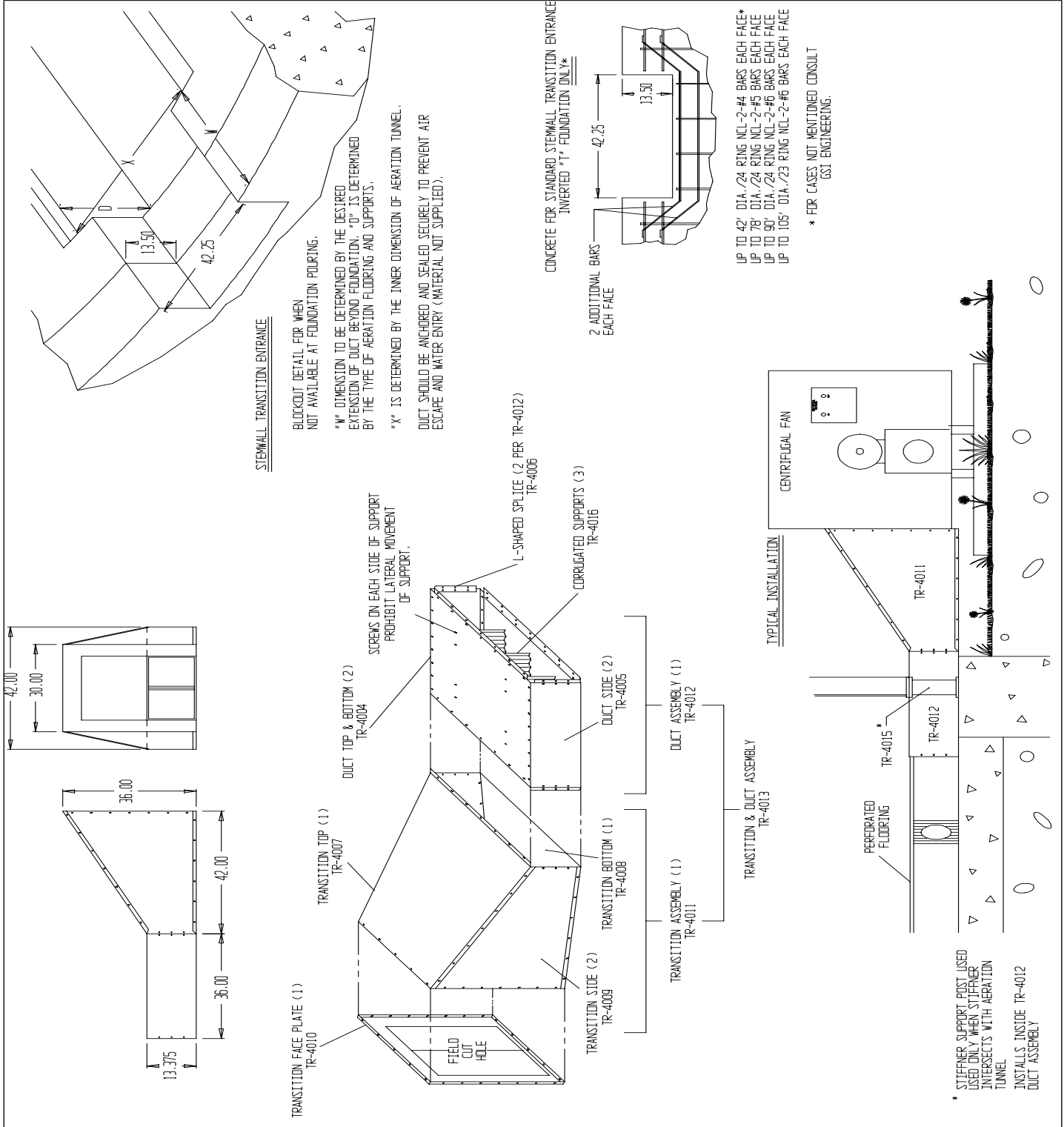

# Transition Entrance Duct Cross Sections

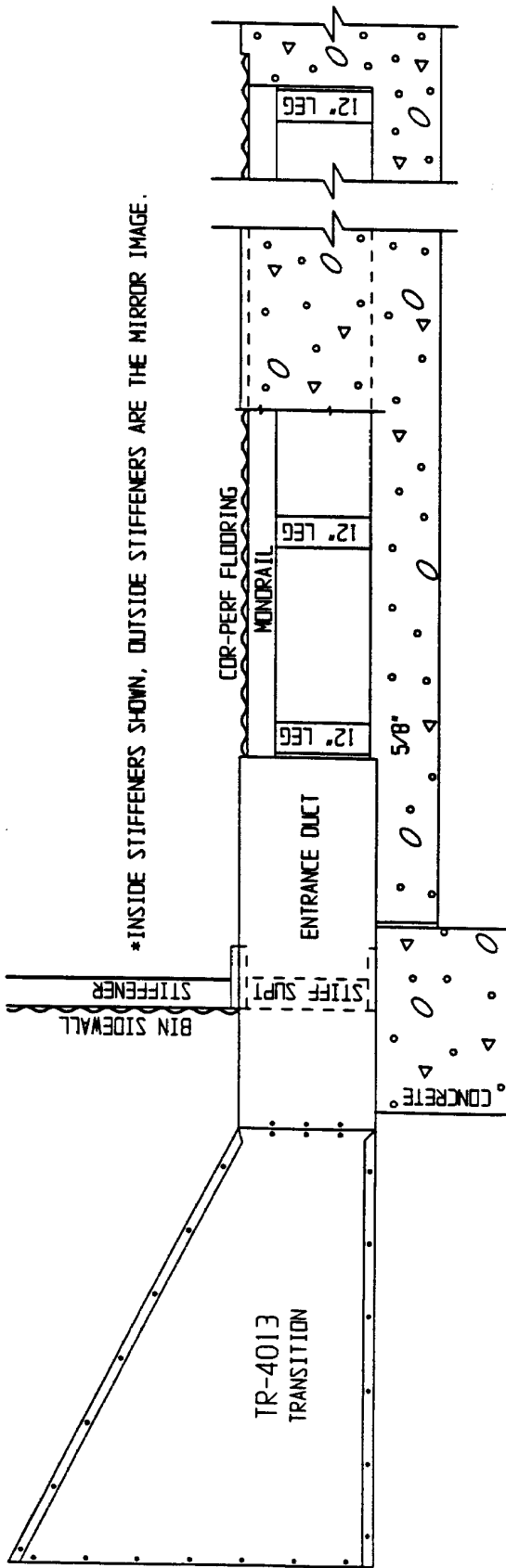

\*INSIDE STIFFENERS SHOWN, OUTSIDE STIFFENERS ARE THE MIRROR IMAGE.

**\*\*NOTE: BOTTOM OF ENTRANCE DUCT IS 5/8" BELOW THE AERATION TRENCH BOTTOM  
COR-PERF FLOORING OVER 12" MONORAIL SYSTEM**

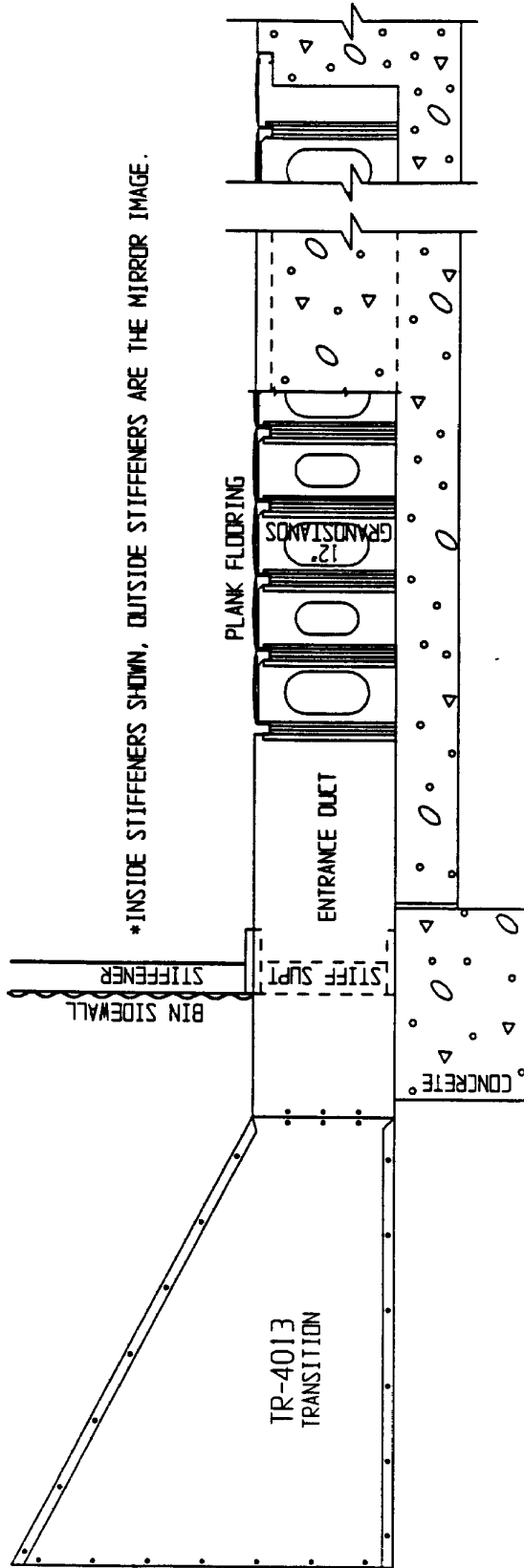

\*INSIDE STIFFENERS SHOWN, OUTSIDE STIFFENERS ARE THE MIRROR IMAGE.

# TR-7140 POST SUPPORT INSTALLATION

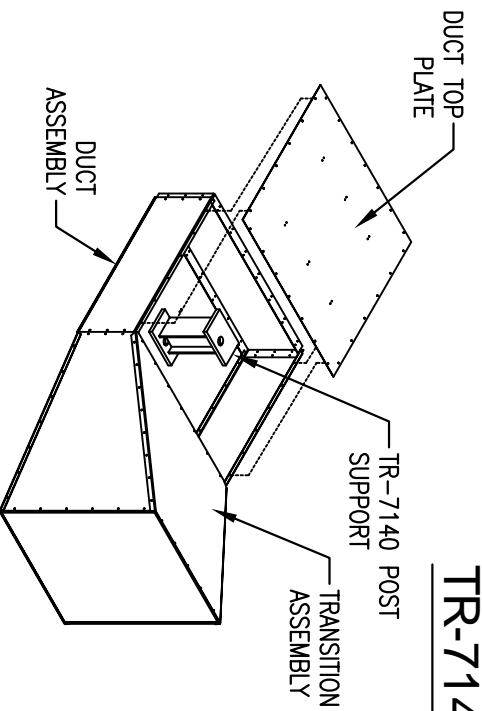

Install the TR-7140 Post Support as shown in the following instructions.

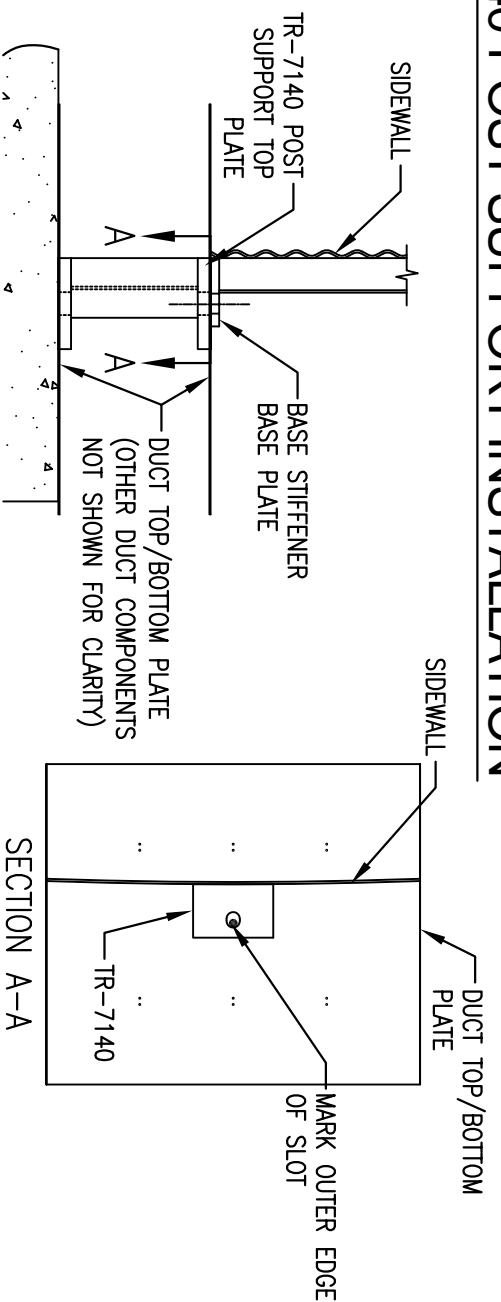

Temporarily install the base stiffener and align the slots in the top plate of the post support with the slots in the base plate on the base stiffener. Mark the duct top/bottom plates as shown in Section A-A and pre-drill for anchor bolt. (Base stiffener cannot be installed until TR-7140 installation is complete).

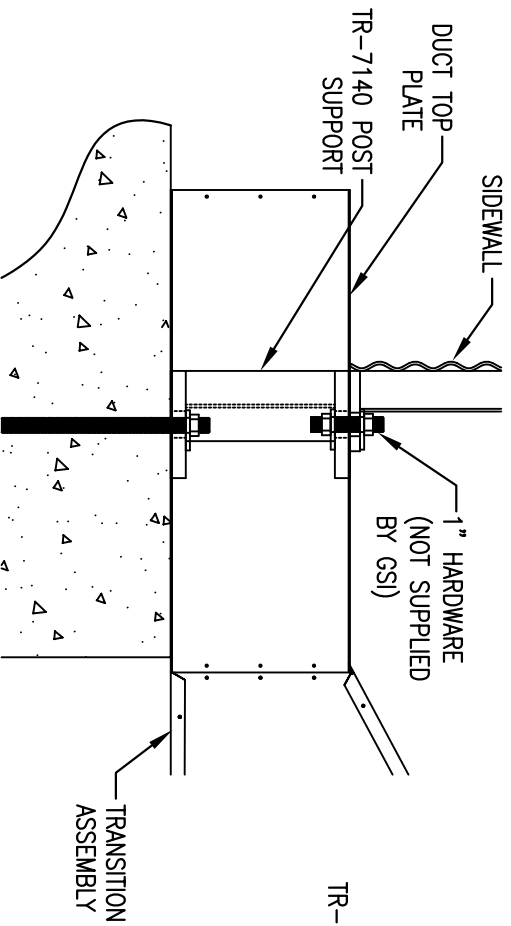

Once the anchor bolt is installed, Place the duct bottom plate and install the TR-7140 weldment through the anchor bolt. Replace the duct top plate and attach the base stiffener to the post support as shown. Secure using standard nuts and square washers.

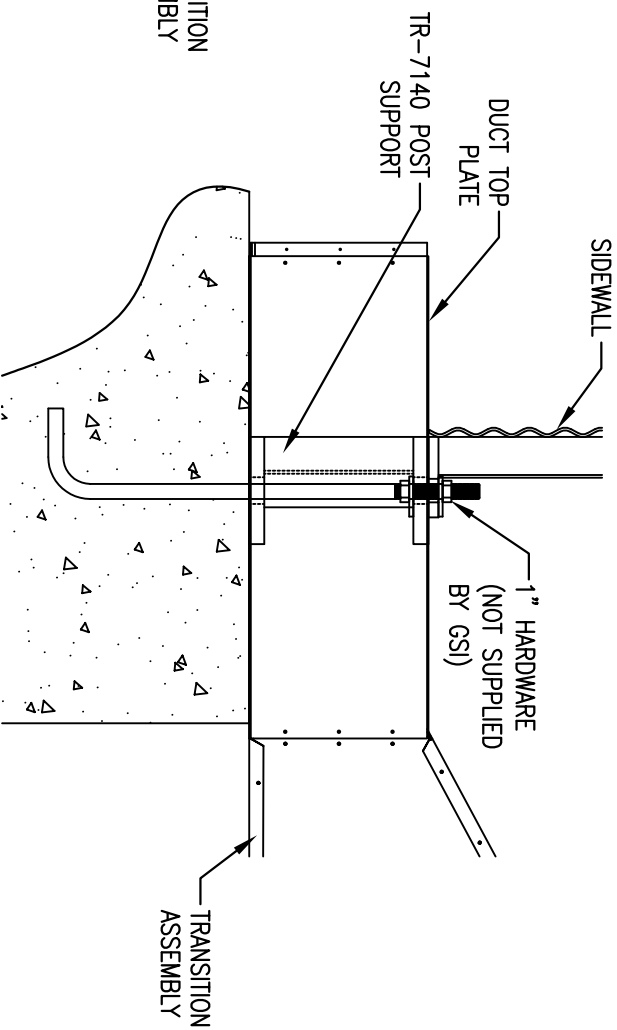

If pre-cast long anchor bolts are used, attach the base stiffener to the post support using standard nuts and square washers as shown above.