



This transition is used in Farm Bin aeration systems (N series bins to 12 rings tall) or in Commercial Tank aeration systems using 12"-18" axial fans. Refer to the Aeration System Plan for trench cross section as well as for trench layout. The cross section views shown below apply to the trench only for the length of the steel inlet duct.

Assembly

Assemble two (2) inlet duct sections (FL-460) to form a box. Assemble transition as shown in *Figure 1* and then bolt (5/16" x 3/4" bin bolts), to inlet duct. Caulk all seams.

IMPORTANT: *If corrugated floor sections are to be used, See Page 2. If Cor-Lok or Cut-Lok floor planks, See Page 3.*

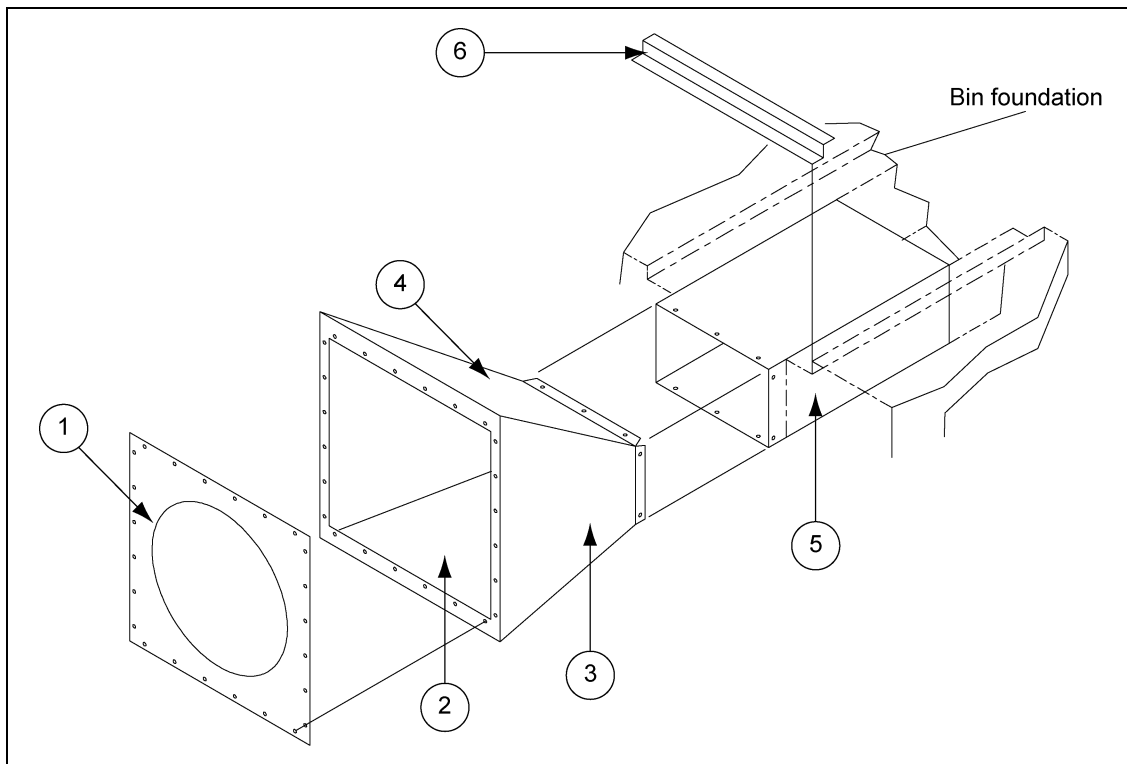

Figure 1

Ref #	Part #	Description	Qty
1	FL-466	Transition Face Plate	1
2	FL-464	Transition Bottom	1
3	FL-465	Transition Side	2
4	FL-463	Transition Top	1
5	FL-460	Inlet Duct Section	2
6	FL-6942	Support Zee Cor-Lok and Cut-Lok Only	1



Flush Floor Aeration (Using TR-1737)

Form Details Using Corrugated Floor Sections

Notch foundation forms as needed to properly locate transition assembly. The transition and inlet duct must be fastened down to resist uplift forces from wet concrete.

NOTE: *Notch for floor planks over inlet duct must match Aeration System Plan. Trench depth beyond inlet duct must also match Aeration System Plan.*

1. Complete form work for aeration system, place rebar and pour concrete.
2. Place floor supports and planks per Aeration System Plan.
3. Install flashing using self-drilling screws into floor planks and ram-sets (not provided by GSI) into concrete.

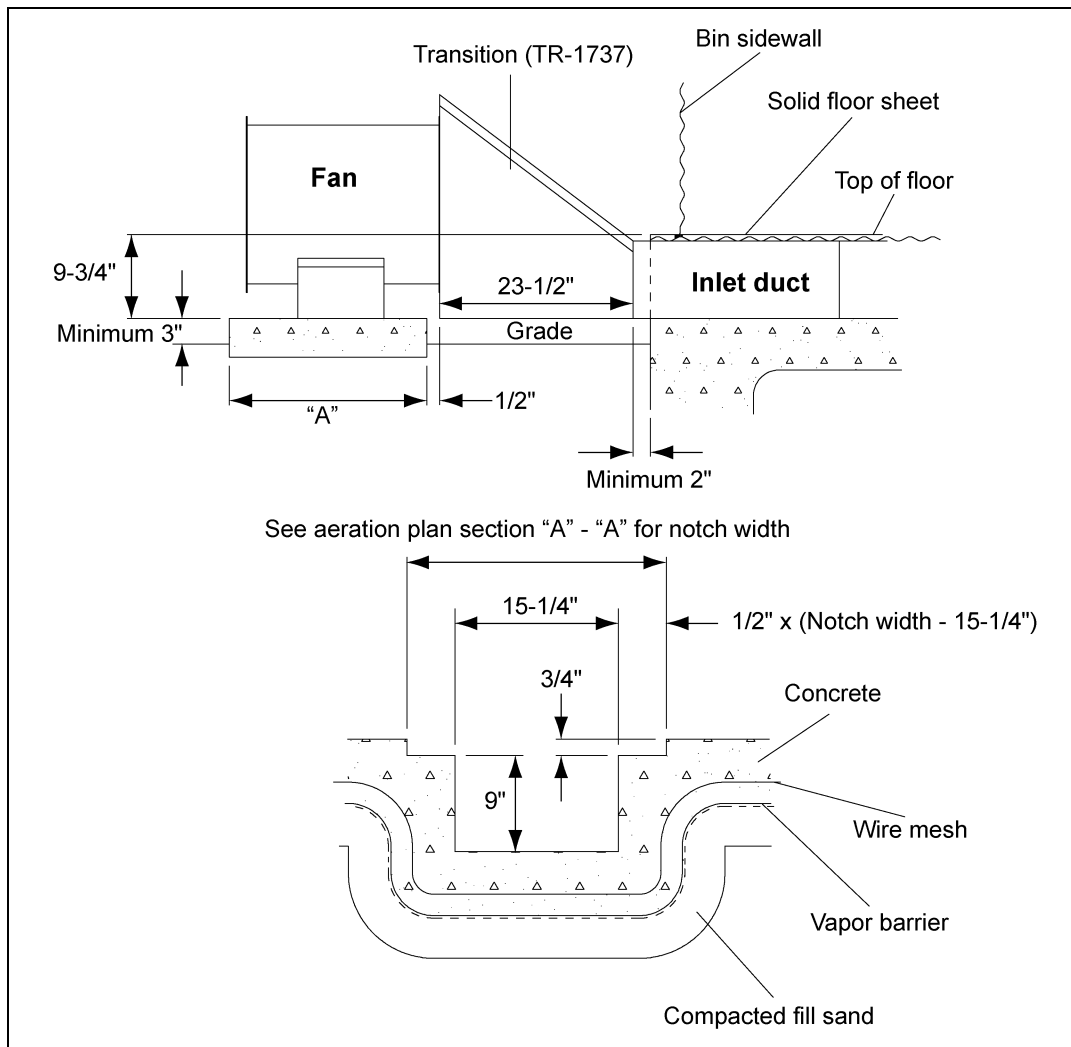

Figure 2

	"A"
18" Fan	23" Sq.
14" Fan	
12" Fan	14" Sq.

Form Details Using Cor-Lok/Cut-Lok Floor Sections

Notch foundation forms as needed to properly locate transition assembly. The transition and inlet duct must be fastened down to resist uplift forces from wet concrete.

NOTE: Notch for floor planks over inlet duct must match Aeration System Plan. Trench depth beyond inlet duct must also match Aeration System Plan.

1. Complete form work for aeration system, place rebar and pour concrete.
2. Place floor supports and planks per Aeration System Plan.
3. Install flashing using self-drilling screws into floor planks and ram-sets (not provided by GSI) into concrete.

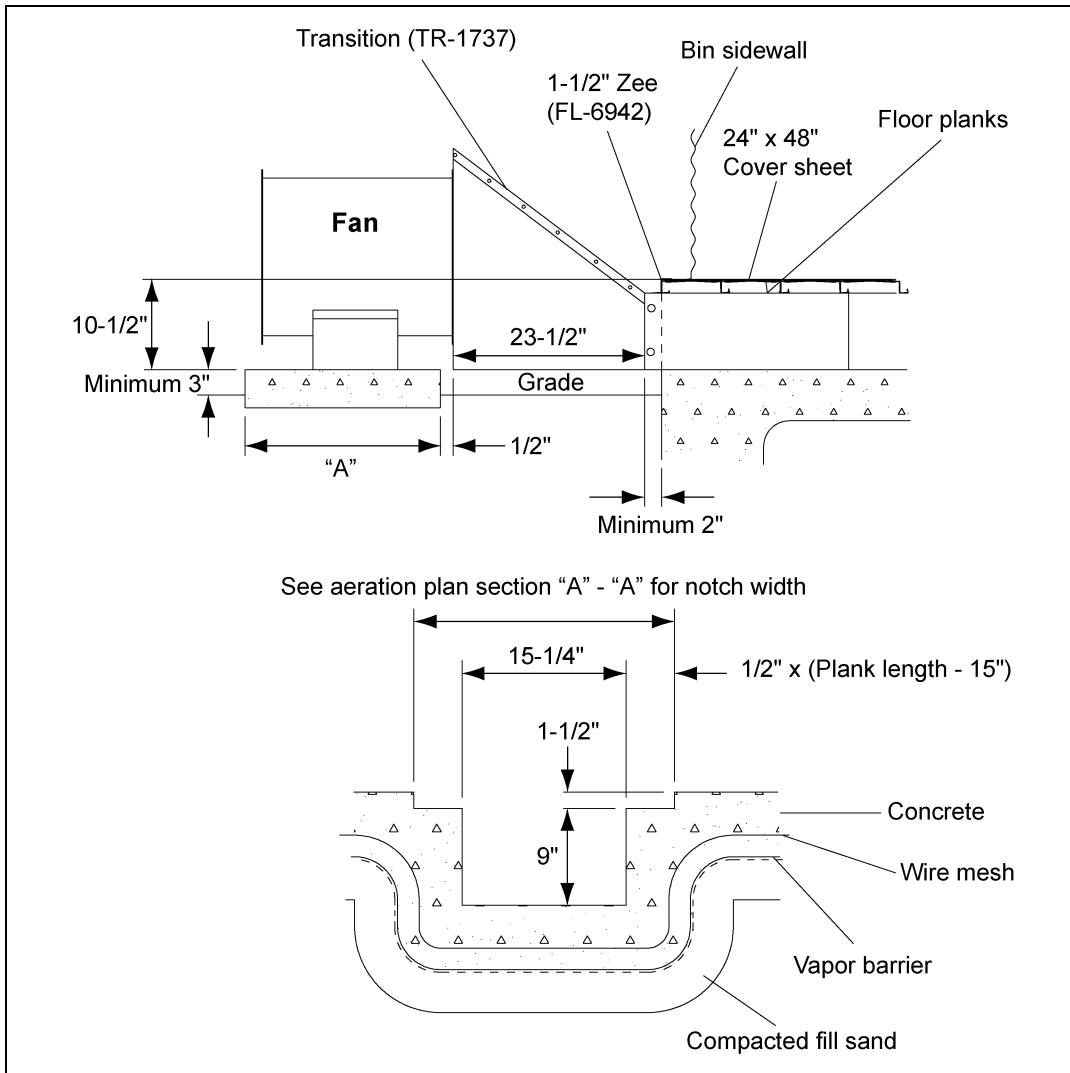

Figure 3

	"A"
18" Fan	23" Sq.
14" Fan	
12" Fan	14" Sq.