

FLASHING INSTRUCTIONS

- 1) LEAVE TOP ROW OF BOLTS OUT OF THE COMPRESSION RING MEMBERS WHEN INSTALLING THE HOPPER PANELS.
- 2) FIELD DRILL THROUGH THE STIFFENERS AND BOLT THROUGH THE SIDEWALL SHEET AND STIFFENER WITH A 5/16" X 1.1/4" BIN BOLT. INSTALL A NEOPRENE WASHER ON THE INSIDE OF THE TANK AND CLAMP IT DOWN AS SHOWN IN DETAIL A-A.
- 3) ATTACH THE FLASHING TO THE COMPRESSION RING MEMBERS USING THE BOLTS PROVIDED. (DO NOT TIGHTEN)
- 4) STARTING WITH A RIGHT HAND FLASHING PIECE, BOLT THE SIDEWALL SHEET LOOSELY TO THE FLASHING USING 5/16" X 1.3/4" BOLTS WITH NEOPRENE WASHER OUTSIDE ONLY THROUGH THE CENTER TWO(2) HOLES. WORKING IN A CLOCKWISE DIRECTION START THE NUT ON THE PREASSEMBLED FLASHING /STIFFENER BOLT.
- 5) BOLT LOOSELY THE TWO(2) CENTER HOLES ON THE LEFT HAND FLASHING PIECE WITH 5/16" X 1.3/4" BOLTS WITH NEOPRENE WASHER OUTSIDE ONLY. USING THE SAME TYPE BOLT AND WASHER, BOLT LOOSELY THE LEFT HAND AND RIGHT HAND LAP SEAM.
- 6) CONTINUE IN THE SAME MANNER UNTILL THE FLASHING IS COMPLETELY ATTACHED. THEN TIGHTEN ALL THE BOLTS SECURELY.
- 7) NOW GO BACK AND INSTALL THE 1/4" SELF-DRILLING SCREWS (S-7229) (SEE DRAWING FOR LOCATIONS)

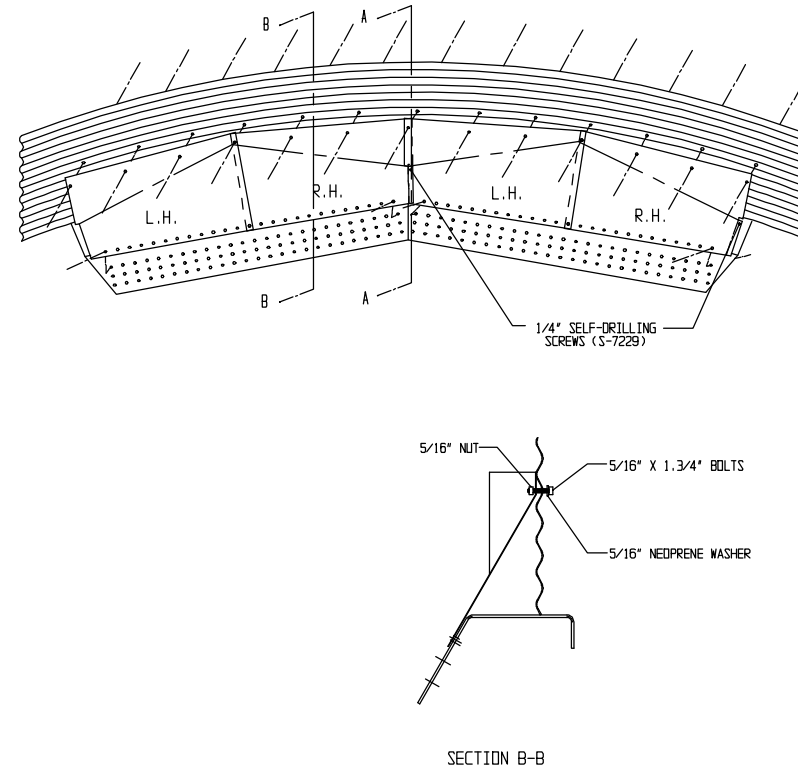
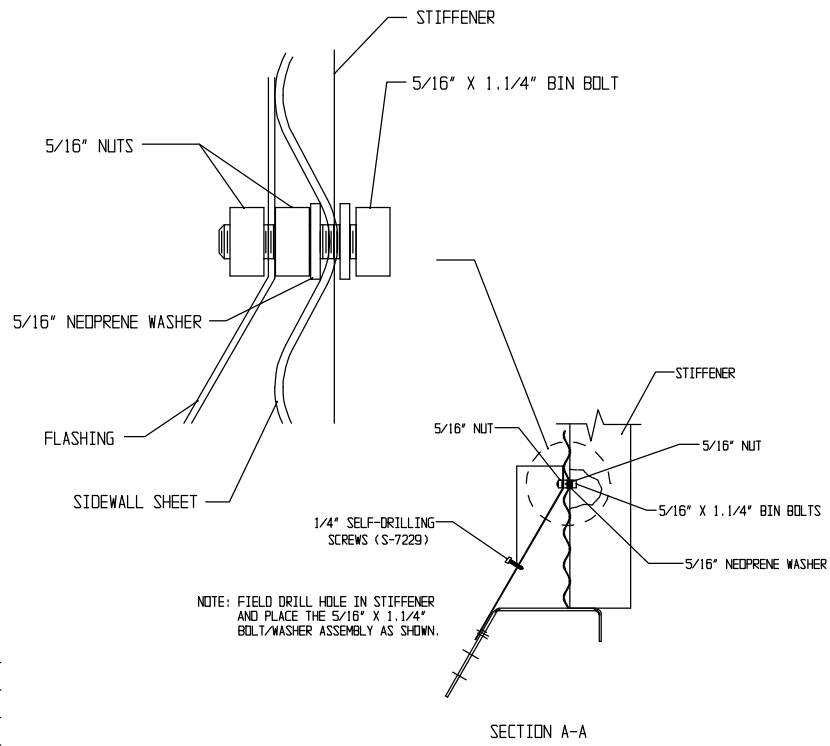

NOTE: FIELD DRILL HOLE IN STIFFENER AND PLACE THE 5/16" X 1.1/4" BOLT/WASHER ASSEMBLY AS SHOWN.

		GRAIN SYSTEMS INCORPORATED		<h2 style="margin: 0;">CHT FLASHING INSTALLATION INSTR.</h2>		TOLERANCES (Unless Noted) Fractions +/- 1/32" Decimals +/- .031" Angles +/- -----			Quantity Sq. Ft. Blk. Wt. Ship Wt. Dim. By J. DECKER Date 9-30-91 Scale NTS Chk'd By Date <small>Work to Dimensions Do Not Scale</small>			Material PNEG-230
No.	ECN	Revision Description	Date	By	Assumption, IL. 62510 217/226-4421							