

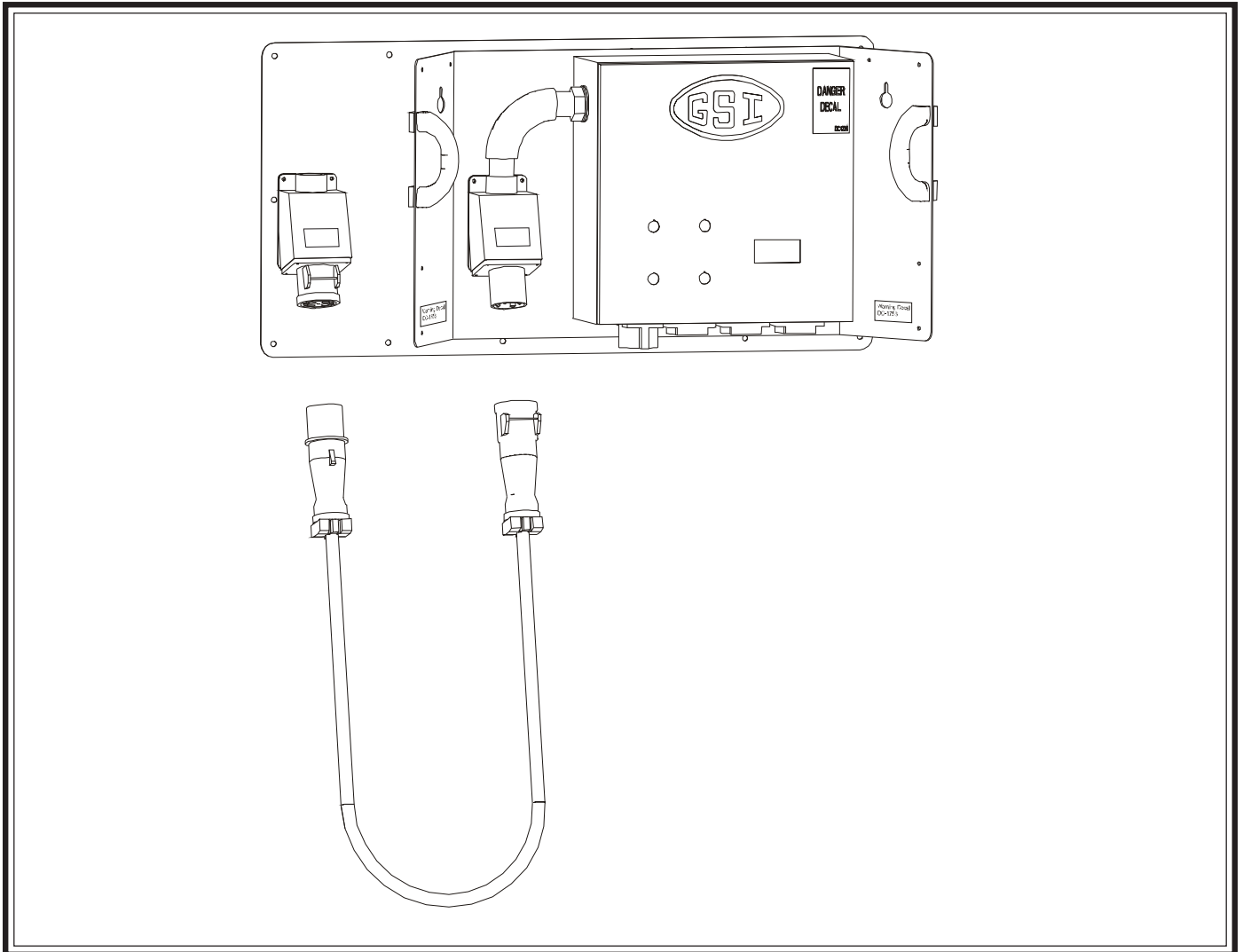

12" & 16" Series II Sweep Quick Disconnect Control Box Kit

Owner's Manual



Model Number :

Date Delivered:

Date Installed:

Notes:

TABLE OF CONTENTS

Product Overview 4
Safety 5
Decals 9
Operator Qualifications 12
Assembly Section
 Docking Station Mount 15
 Control Panel Installation 17
 Place Control Panel Onto Docking Station 18
 Control Panel Setup 19
Start-Up 21
Operation 23
Shutdown 25
Maintenance 26
Control Panel Schematics 27
Troubleshooting 30
Part Lists 31
Warranty Inside Back Cover

Personnel operating or working around this equipment should read this manual. This manual must be delivered with equipment to its owner. Failure to read this manual and its safety instructions is a misuse of the equipment. Any misuse of the equipment may void the warranty.

Product Overview

The Quick Disconnect Control Box was designed to work 12" & 16" GSI Series 2 Sweeps. This Quick Disconnect Control Box modular design will allow you to move the control box to each sweep location, therefore only one control box is needed to control all of your same size sweeps. Each sweep location will require a docking station for the control box base to slide into. The control box base is supplied with four handles for manual lifting. These handles can be installed in any of the holes located on the outside edges of the base back plate. The base back plate also has two Chain Lift Holes for mechanical hoisting. *Caution: Never attempt to lift the Control Box by yourself. Always use two or more persons with proper lifting equipment.*

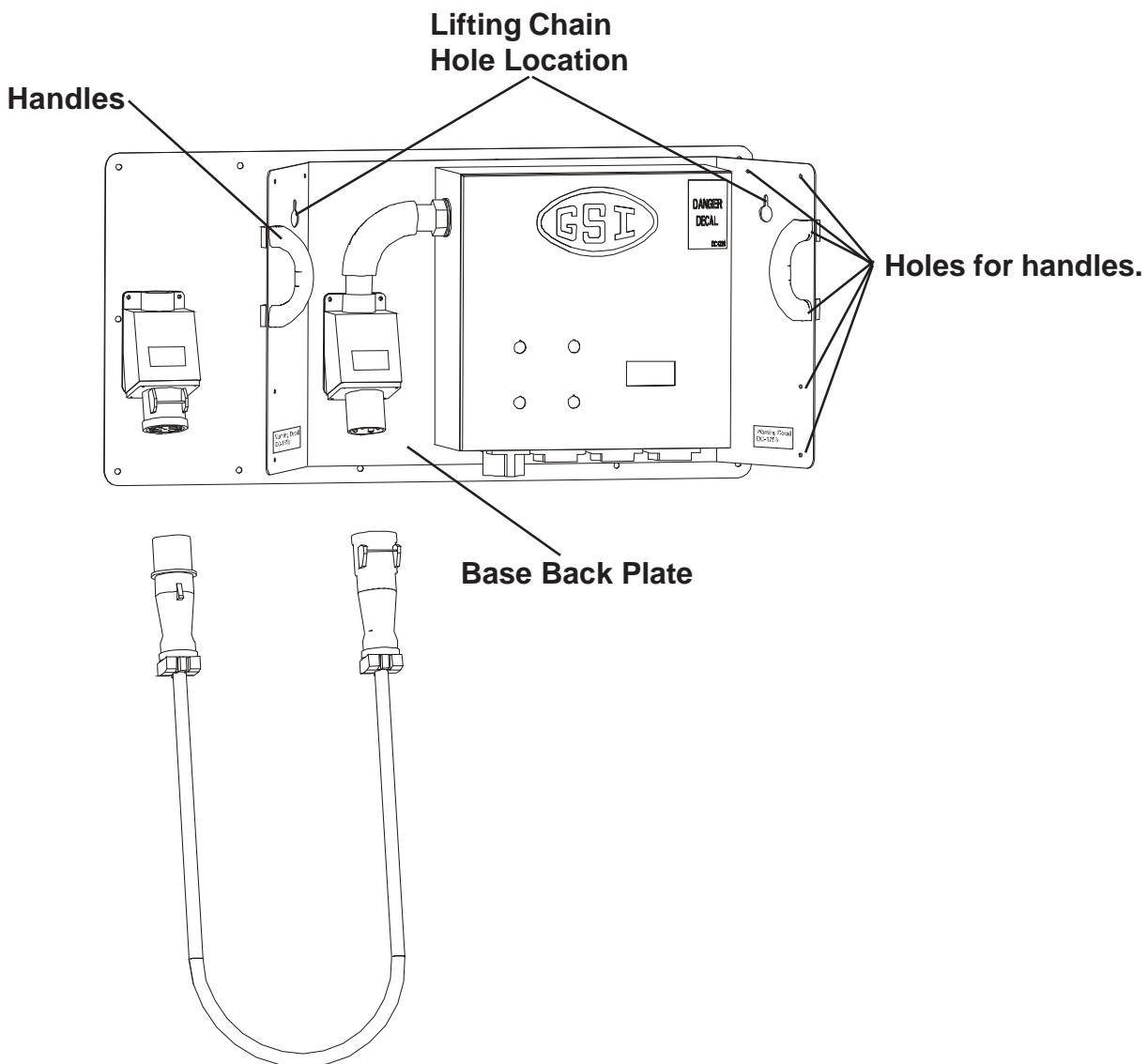

SAFETY GUIDELINES

This manual contains information that is important for you, the owner/operator, to know and understand. This information relates to protecting **personal safety** and **preventing equipment problems**. It is the responsibility of the owner/operator to inform anyone operating or working in the area of this equipment of these safety guidelines. To help you recognize this information, we use the symbols that are defined below. Please read the manual and pay attention to these sections. Failure to read this manual and its safety instructions is a misuse of the equipment and may lead to serious injury or death.



This is the safety alert symbol. It is used to alert you to potential personal injury hazards. Obey all safety messages that follow this symbol to avoid possible injury or death.

 **DANGER**

DANGER indicates an imminently hazardous situation which, if not avoided, will result in death or serious injury.

 **WARNING**

WARNING indicates a potentially hazardous situation which, if not avoided, could result in death or serious injury.

 **CAUTION**

CAUTION indicates a potentially hazardous situation which, if not avoided, may result in minor or moderate injury.

CAUTION

CAUTION used without the safety alert symbol indicates a potentially hazardous situation which, if not avoided, may result in property damage.

NOTE

NOTE indicates information about the equipment that you should pay special attention to.

FOLLOW SAFETY INSTRUCTIONS

Carefully read all safety messages in this manual and safety signs on your equipment. Keep signs in good condition. Replace missing or damaged safety signs. Be sure new equipment components and repair parts include the current safety signs. Replacement safety signs are available from the manufacturer.

Learn how to operate the machine and how to use controls properly. Do not let anyone operate without instruction. Keep unqualified personnel out of the work area at ALL times.

Keep your machinery in proper working condition. Unauthorized modifications to the machine may impair the function and/or safety and affect machine life.

Never work alone.

Never start equipment until all personnel are clear of the work area.

Never attempt to assist machinery or try to remove trash from equipment while in operation.

Keep all guards in place during operation.

Always lock out power to equipment when work is finished.

If you do not understand any part of this manual and need assistance, contact your dealer.

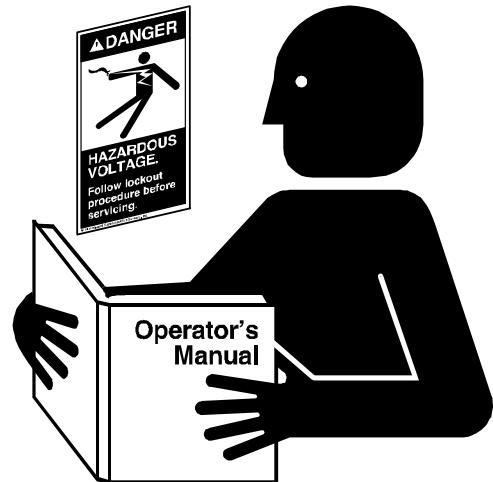

Read ALL Safety Information and instructions before operating machinery.

LIFTING HAZARD

Do not lift equipment without personal or mechanical assistance. Single person lift could cause injury.

To avoid muscle strain or back injury, use lifting aids and proper lifting techniques when removing or replacing the control box.

Use Proper Lifting Equipment.

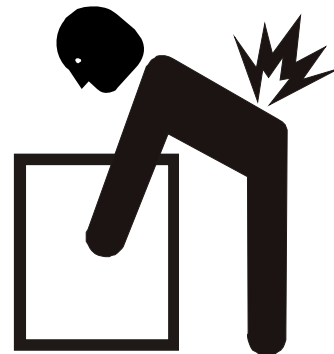

INSTALL & OPERATE EQUIPMENT PROPERLY

This equipment shall be installed in accordance with the current installation codes and applicable regulations which should be carefully followed in all cases. Authorities having jurisdiction should be consulted before installations are made.

Electrical controls should be installed by a qualified electrician and must meet standards set by the national electrical code and all local and state codes.

A main power disconnect switch capable of being locked only in the OFF position should be used. The Disconnect must be LOCKED in the OFF position before unplugging either end of the power cord.



Electric Shock Hazard.

PRACTICE SAFE MAINTENANCE

ALWAYS turn off & lock out all power sources before performing any maintenance.

Understand service procedures before doing work. Keep area clean and dry.

Never lubricate, service, or adjust machine while it is in operation. Keep hands, feet, and clothing from rotating parts. Replace all guards.

Keep all parts in good condition and properly installed. Fix damage immediately. Replace worn or broken parts. Remove any build up grease, oil, or debris.

Lockout Power.



Keep Work Area Clean.



Replace Guards.

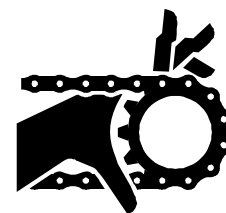

WEAR PROTECTIVE CLOTHING

Wear close fitting clothing and safety equipment appropriate to the job. Keep hair, loose clothing, & shoestrings away from rotating & moving parts.

Safety glasses should be worn at all times to protect eyes from debris.

Wear gloves to protect your hands from sharp edges on plastic or steel parts.

A respirator may be needed to prevent breathing potentially toxic fumes and dust.

Wear hard hat and steel toe boots to help protect your head and toes from falling debris.

Eye Protection

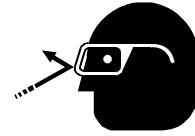

Gloves



Steel Toe Boots



Respirator



Hard Hat



PREPARE FOR EMERGENCIES

Make sure someone is nearby who is aware of the proper shutdown sequence in the event of an accident or emergency.

Be prepared if fire starts.

Keep a first aid kit and fire extinguisher handy.

Keep emergency numbers for doctors, ambulance service, hospital, and fire department near your telephone.

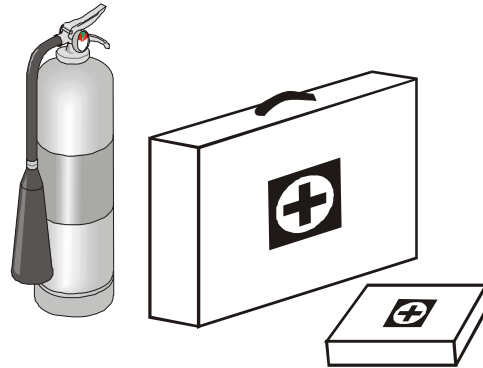

Have Emergency Equipment Ready.

1. DECALS

A. The image below shows the location of the decals and safety signs which should appear on the Control Panel and Quick Disconnect Control Kit.

NOTE Please remember safety signs provide important safety information for people working near bin unloading equipment that is in operation. Any safety signs that are worn, missing, illegible or painted over should be replaced immediately. Obtain **FREE** replacements by contacting GSI.

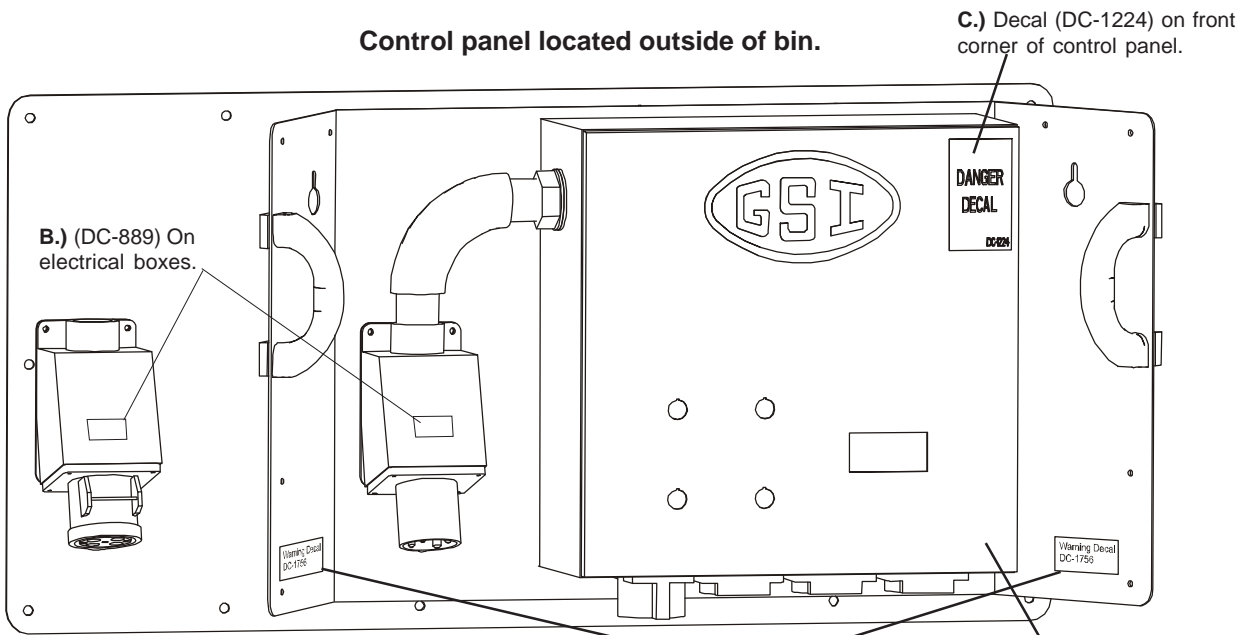

A) DC-1756
 Location: Corners of mounting plate.
 Size: 4 3/4" x 2 1/4"



B) DC-889
 Location: Interior of Control Panel.
 On electrical boxes.
 Size: 2 13/16" x 1 7/16"

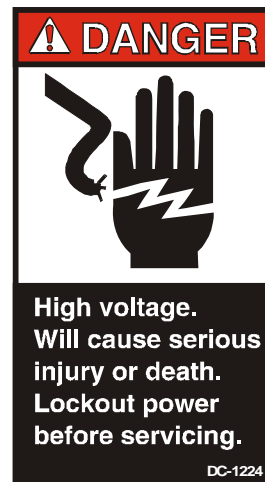

C) DC-1224
 Location: Corner of Control Panel.
 Size: 2 7/8" x 5"

1. DECALS (CONT.)

- B. DANGER Sign No. DC-1395 was supplied with your bin unloading equipment. This safety sign should be applied to the side of the bin near the bin opening, so it will be viewed by people entering into the bin storage building. Do not cover any safety signs or any other signs that are already there.
- C. If the safety sign location suggested is not in full view because of equipment modifications, other equipment in the area or any reason, then locate the safety sign in a more suitable location.
- D. Be certain the surface is clean, dry and free of dirt and oil. Peel paper backing from decals and stick into place. The adhesive backing will bond on contact.

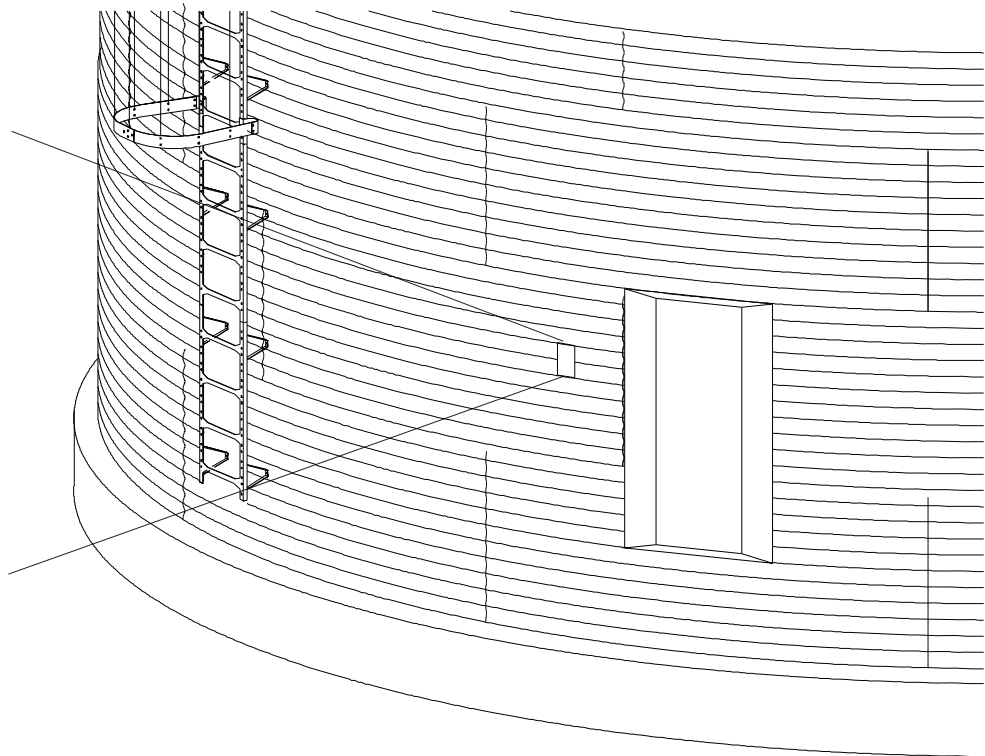

If the Safety Sign cannot be easily read for any reason or has been painted over, replace it immediately.

NOTE

Additional Safety Signs may be obtained free of charge from your dealer, distributor or ordered from the factory.

Order SAFETY SIGN NO. DC-1395

2. OPERATOR QUALIFICATIONS.

- A. The User/Operator must be competent and experienced to operate auger equipment. Anyone who works with or around augers must have good common sense in order to be qualified. These persons must also know and meet all other qualifications, such as:
1. Any person who has not read and/or does not understand all operation and safety instructions is not qualified to operate any auger systems.
 2. Certain regulations apply to personnel operating power machinery. Personnel under the age of 18 years may not operate power machinery, including augers. It is your responsibility, as owner and/or supervisor, to know what these regulations are in your area or situation.
 3. Unqualified or incompetent persons are to remain out of work area.
 4. O.S.H.A. (Occupational Safety & Health Administration) regulations state: "At the time of initial assignment and at least annually thereafter, the employer shall instruct every employee in the safe operation and servicing of all equipment with which the employee is, or will be involved." (Federal Occupational Safety & Health Standards for Agriculture. Sub part D, Section 19287.57 (a) (6).
- B. As a requirement of OSHA, it is necessary for the employer to train the employee in the safe operating and safety procedures for this auger. We included this sign-off sheet for your convenience and personal record keeping. All unqualified people are to stay out of the work area at all times. It is strongly recommended that another qualified person who knows the shutdown procedure is in the area in the event of an emergency. A person who has not read this manual and does not understands all operating and safety instructions, is not qualified to operate the machine.

<i>Date</i>	<i>Employees Name (printed)</i>	<i>Employees Signature</i>
	1	
	2	
	3	
	4	
	5	
	6	
	7	
	8	
	9	
	10	
	11	
	12	
	13	
	14	
	15	
	16	
	17	
	18	
	19	
	20	
	21	
	22	
	23	
	24	
	25	



NEVER enter a grain bin unless **ALL** power driven equipment has been shutdown. Disconnect and lockout power before entering the bin or servicing the equipment.

1. GENERAL INFORMATION.

- A. GSI reserves the right to improve its product whenever possible and practical to do so. We reserve the right to change, improve and modify products at any time without obligation to make changes, improvements and modifications on equipment sold previously.
- B. This new bin sweep auger has been engineered and manufactured to give years of dependable service. The care and maintenance of this equipment will affect the satisfaction and service obtained. By following the instructions and suggestions recommended, the owner should receive quality service for many years. If additional information or assistance should be required, please contact GSI.
- C. It is important to check both the quantity of parts and their descriptions with the packing list enclosed within each package. All claims for freight damage or shortage must be made by the consignee within ten (10) days from the date of the occurrence of freight damage. The consignee should accept the shipment after noting the damage or loss.

2. CAPACITIES AND SPECIFICATIONS

⚠ WARNING

Electrical controls and wiring should be installed by a qualified electrician. The motor disconnect switches and conductor cables should comply with the National Electrical code and any local codes which apply. Reset and motor starting stations should be located so the operator can see that all personnel are clear of the equipment.

A. Use the chart below to determine the horsepower required.

Bin Diameter	12" SERIES II SWEEP					16" SERIES II SWEEP				
	Drive H.P.	Bushel/MT Per Hour Horsepower			Length Pivot to End	Drive H.P.	Bushel/MT Per Hour Horsepower			Length Pivot to End
		5000/125	6000/155	7000/180			8000/205	9000/230	10000/255	
36'	1	7.5	7.5	7.5	16.79' (5.12m)	2	7.5	7.5	7.5	16.85' (5.14m)
37'	1	7.5	7.5	7.5	17.79' (5.43m)	2	7.5	7.5	7.5	16.85' (5.14m)
39'	1	7.5	7.5	7.5	18.79' (5.73m)	2	7.5	7.5	7.5	17.85' (5.44m)
40'	1	7.5	7.5	7.5	18.79' (5.73m)	2	7.5	7.5	7.5	18.75' (5.72m)
42'	1	7.5	7.5	7.5	19.79' (6.04m)	2	7.5	7.5	10	19.85' (6.05m)
43'	1	7.5	7.5	7.5	20.79' (6.34m)	2	7.5	7.5	10	19.85' (6.05m)
45'	1	7.5	7.5	7.5	20.79' (6.34m)	2	7.5	7.5	10	20.85' (6.36m)
48'	1	7.5	7.5	7.5	22.79' (6.95m)	2	7.5	10	10	22.85' (6.96m)
49'	1	7.5	7.5	7.5	22.79' (6.95m)	2	7.5	10	10	22.85' (6.96m)
51'	1	7.5	7.5	10	23.79' (7.26m)	2	7.5	10	10	23.85' (7.27m)
54'	1	7.5	7.5	10	25.79' (7.86m)	2	10	10	10	25.85' (7.88m)
55'	1	7.5	7.5	10	25.79' (7.86m)	2	10	10	10	25.85' (7.88m)
57'	1	7.5	7.5	10	26.79' (8.17m)	2	10	10	10	26.85' (8.18m)
59'	1	7.5	7.5	10	27.79' (8.47m)	2	10	10	15	27.85' (8.49m)
60'	1	7.5	7.5	10	28.79' (8.78m)	2	10	10	15	28.85' (8.79m)
62'	2	7.5	7.5	10	29.79' (9.08m)	2	10	10	15	29.85' (9.10m)
63'	2	7.5	7.5	10	29.79' (9.08m)	2	10	10	15	29.85' (9.10m)
66'	2	7.5	7.5	10	31.79' (9.69m)	2	10	15	15	31.85' (9.71m)
68'	2	7.5	7.5	10	32.79' (10.00m)	2	10	15	15	32.85' (10.01m)
69'	2	7.5	7.5	10	32.79' (10.00m)	2	10	15	15	32.85' (10.01m)
72'	2	7.5	7.5	10	34.79' (10.61m)	2	15	15	15	34.85' (10.62m)
75'	2	10	10	10	35.79' (10.91m)	2	15	15	15	35.85' (10.93m)
78'	2	10	10	10	37.79' (11.52m)	2	15	15	15	37.85' (11.54m)
80'	2	10	10	10	38.79' (11.83m)	2	15	15	15	38.85' (11.84m)
81'	2	10	10	10	38.79' (11.83m)	2	15	15	15	38.85' (11.84m)
84'	2	10	10	15	40.79' (12.44m)	2	15	15	15	40.85' (12.45m)
87'	2	10	10	15	41.79' (12.74m)	2	15	15	20	41.85' (12.76m)
88'	2	10	10	15	42.79' (13.05m)	2	15	15	20	42.85' (13.06m)
90'	2	10	10	15	43.79' (13.35m)	2	15	15	20	43.85' (13.37m)
91'	2	10	10	15	43.79' (13.35m)	2	15	15	20	43.85' (13.37m)
92'	2	10	10	15	44.79' (13.66m)	2	15	20	20	44.85' (13.67m)
95'	2	10	15	15	45.79' (13.97m)	2	15	20	20	45.85' (13.98m)
98'	2	10	15	15	47.79' (14.57m)	2	15	20	20	47.85' (14.58m)
105'	3	15	15	20	50.79' (15.48m)	3	20	20	20	50.85' (15.50m)
113'	3	15	15	20	54.79' (16.70m)	3	20	20	20	54.85' (16.72m)
120'	3	15	15	20	58.79' (17.92m)	3	20	20	20	58.85' (17.94m)

Due to continual improvements, GSI designs and specifications are subject to change without notice.

NOTE

The horsepower recommendations are for augering reasonably dry grain. High moisture grain (greater than 15%) will require greater power for maximum capacity. The maximum capacity will be less with high moisture grain than with dry grain.

ALSO NOTE: Sweep drive and carrier wheels require plates or track over aeration flooring for travel and supports not supplied with the sweep unit. Contact your installer or flooring provider for possible source and details.

2. CAPACITIES AND SPECIFICATIONS (CONT.)

- B. A magnetic starter should be used to protect the motor when starting and stopping. It should stop the motor in case of power interruption, conductor fault, low voltage, circuit interruption or motor over load. The motor must be restarted manually. Some motors have built-in thermal overload protection. If this is the type of motor being used, use only those with a manual reset.
- C. The motor starting controls must be located outside the bin. They must NEVER be installed on the Series II auger inside the bin.
- D. Disconnect and lockout the power before resetting motor overloads.
- E. Disconnect and lockout the power before entering the bin.
- F. Disconnect and lockout the power before servicing the equipment.
- G. Position the reset and motor starting controls so that the operators have full view of the equipment

⚠ CAUTION

There should ALWAYS be two (2) people in the work area.

- H. Make sure electric motors are grounded.

⚠ DANGER

A main power disconnect switch capable of being locked only in the OFF position should be used. The disconnect must be locked in the off position before unplugging either end of the cord. It should also be locked whenever work is being done on the Series II Sweep.

1. DOCKING STATION MOUNT

- A. Securely mount the Docking Station outside of the bin near the bin door. The drawing below shows the hole pattern and diameter. The docking station must be close enough to the bin door to plug in the 10' long foot switch cord. The operator must be outside of the bin and be able to depress the foot switch while visually monitoring the sweep thru the bin door.

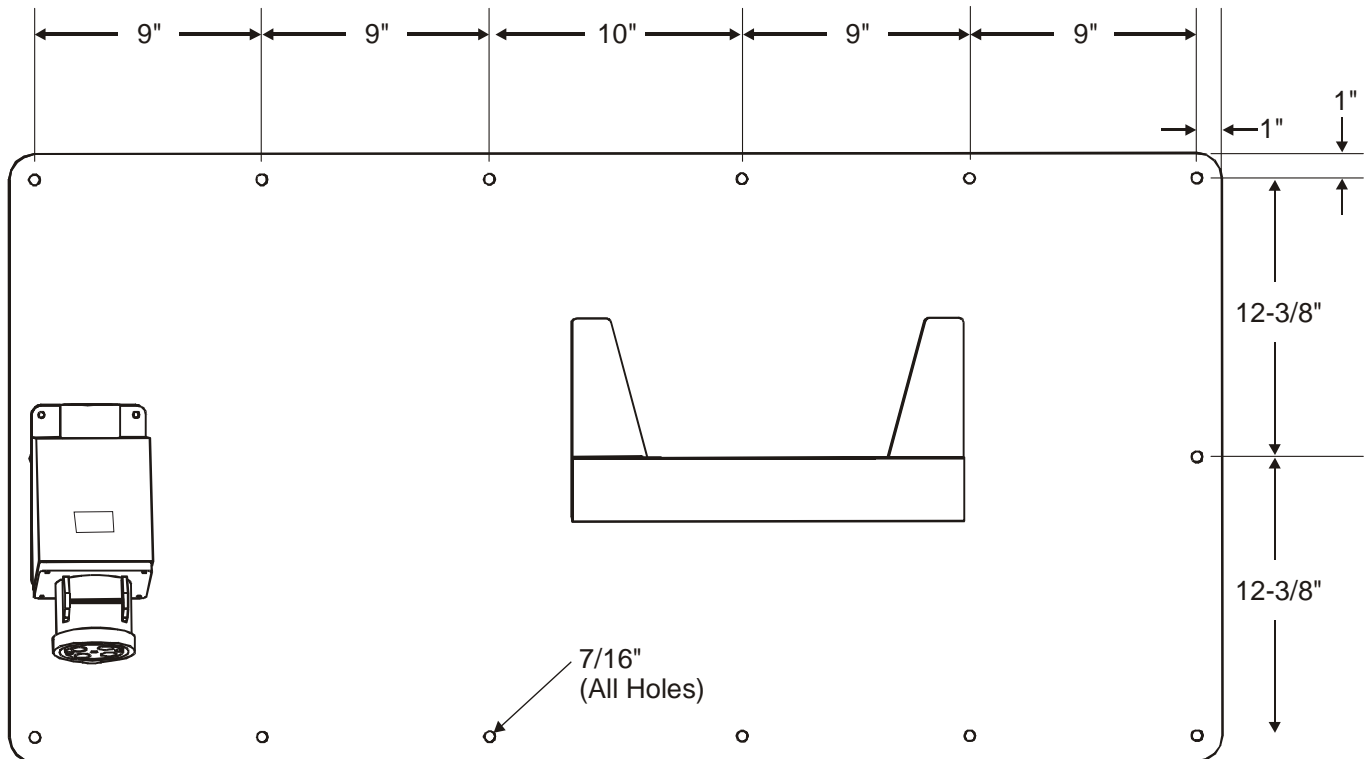

Docking Station

⚠ DANGER

The control panel must be mounted outside the bin near the door. The foot switch has to be plugged into the control panel and depressed before the sweep is operational. It has a 10' cord so the sweep can only be monitored from outside the bin.

1. CONTROL PANEL CONDUIT HOLE

NOTE

The Series 2 sweep has used 2 different control boxes. The quick disconnect kit will fit either style box. Hardware is provided to mount an old style box (with ears) to the mounting plate. The new styles box already has hardware installed in the rear of the box.

- A. Cut a hole into the side panel of the control box in the location shown below. Hole to be sized for 1-1/2" Rigid Conduit (Approximately 1.900"). Make sure all metal chips/shavings are removed from the inside of the box.

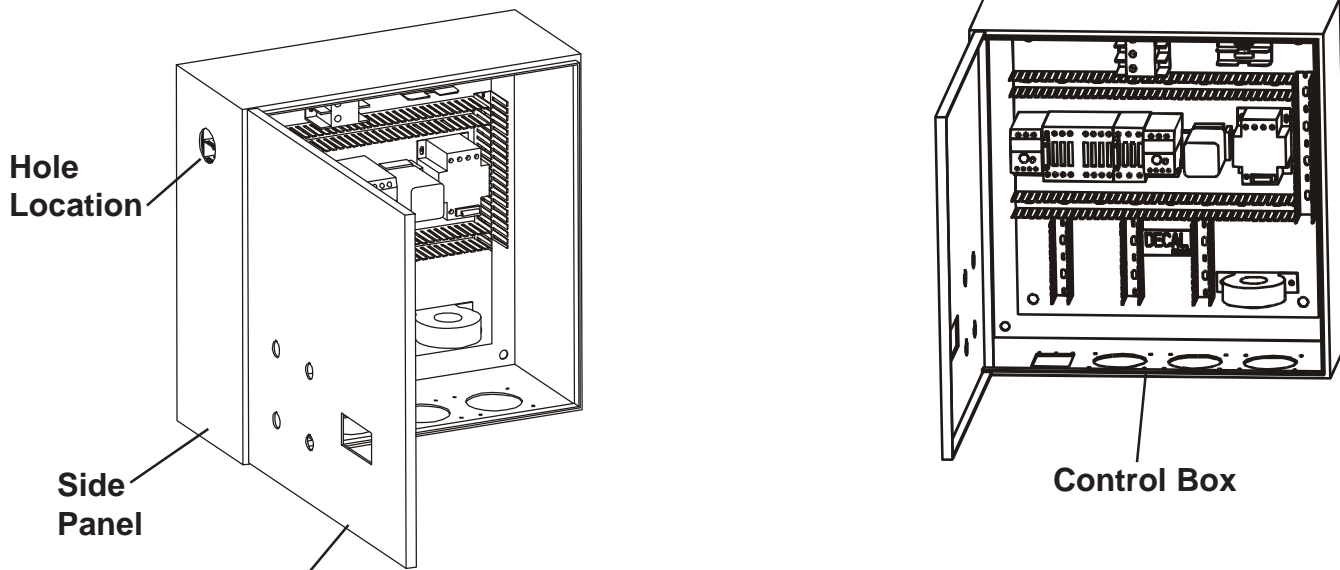

Side Panel

Front Panel

Control Box

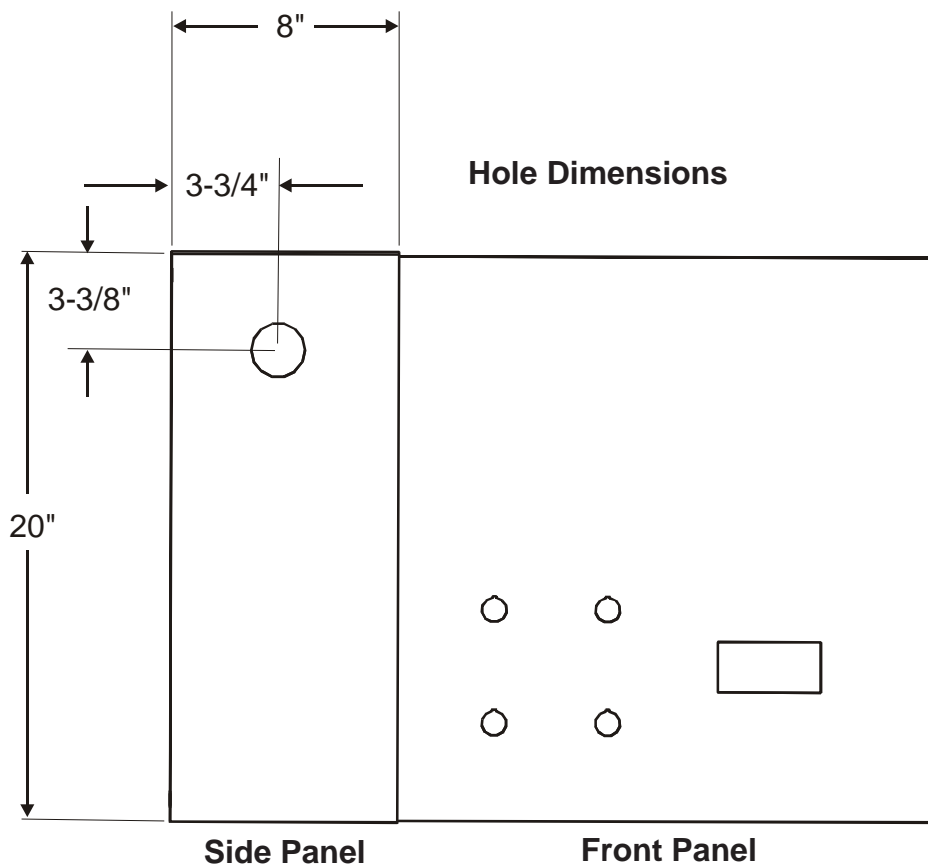

2. CONTROL PANEL INSTALLATION

Electrical controls should be installed by a qualified electrician and must meet standards set by the national electrical code and all local and state codes.

▲WARNING

A main power disconnect switch capable of being locked only in the OFF position should be used. The Disconnect must be LOCKED in the OFF position before unplugging either end of the power cord.

- A. Remove the lock nut from the conduit hub. The conduit hub is factory installed on the conduit assembly attached to the Back Base Assembly.
- B. Carefully inset the conduit hub, with wires, into the hole drilled during step 1-A on page 16.
- C. Install the lock nut on the hub and tighten.
- D. Mount the control box to the back plate with the supplied hardware.
- E. Use the supplied grounding lug (E160-1137) to properly ground the control box assembly to the outlet.

Use 1/4"-14 x 1-1/4" screws for handles that attach to the base back plate at the stiffener bar locations. Use 1/4"-14 x 1" screws for handles that attach at all other locations.

▲WARNING

Using the wrong size screws can cause the threads to strip or not give enough support and **serious injury** or **death** can occur.

- F. Attach handles. Four (4) handles are supplied and can be located in any of the holes on the outside edges of the back base plate. USE THE CORRECT SIZE SCREWS!!!! (Only two handles shown.)

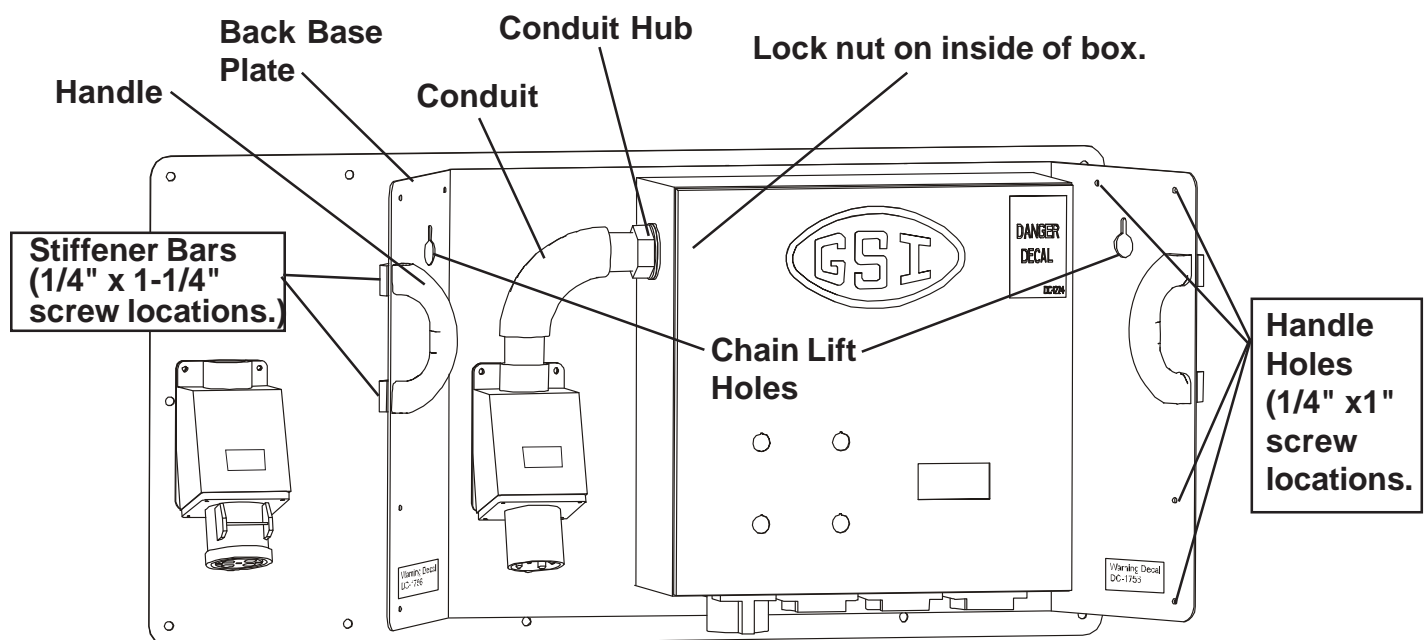

3. PLACE CONTROL PANEL INTO DOCKING STATION

- A. Attach the control box to the docking station by sliding the tongue into the pocket on the docking station.
(See Illustration Below.)

▲ WARNING

Do not lift equipment without personal or mechanical assistance.
Single person lift could cause injury.
To avoid muscle strain or back injury, use lifting aids and proper lifting techniques when removing or replacing the control box.

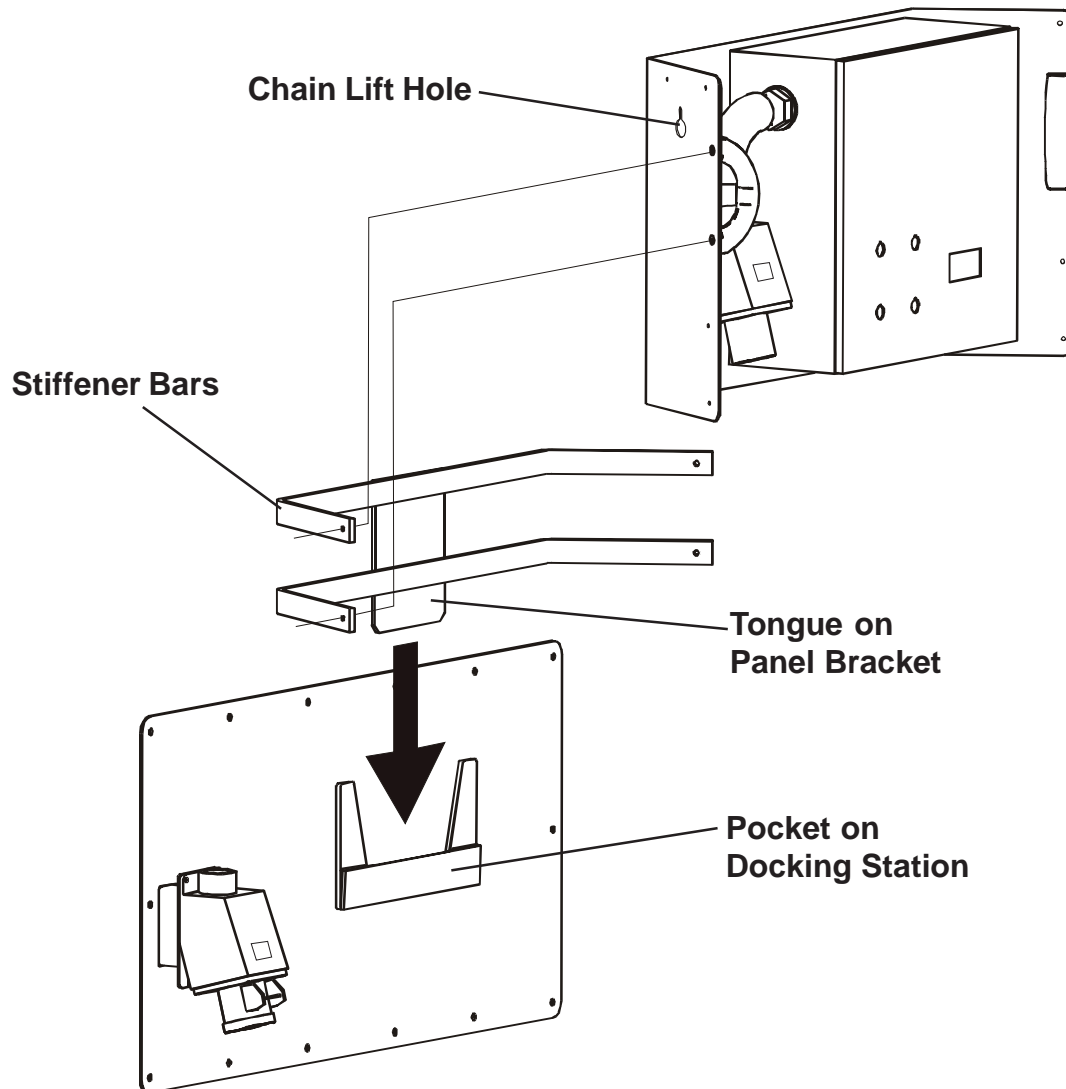

5. CONTROL PANEL SETUP

NOTE

The control panel may have to be reprogrammed for peak performance after being moved to a different bin.

The bin must have grain in it to be able to properly program the control panel.

- A. Find the desired "High" amp and "Low" amp set points.
1. High Amp Set Point: The amp load applied to the auger motor with the auger flighting 90% loaded. This will turn off the drive motor.
 2. Low Amp Set Point: The amp load applied to the auger motor with the auger flighting 10% loaded. This will turn on the drive motor.

CAUTION

NEVER program the "High Amp Set Point" greater than the full load running amps of the auger motor.

B. Programming the Amp Meter

1. Setting Input
 - a. Press "PRGM" to "inPut".
 - b. Press "ENTER".
 - c. Press "PRGM" to "i4-20".
 - d. Press "ENTER" to RUN MODE.

2. Setting Setup
 - a. Press "PRGM" to "SEtuP".
 - b. Press "ENTER" to "rdEC"
Use arrow buttons to change the decimal placement. Show .0 Amps.
 - c. Press "ENTER" to "SETLO"
 - d. Press "ENTER"
Value = 0.0
 - e. Press "ENTER" to "SEtHi".
 - f. Press "Enter"
Value = 50
Use arrow buttons to change value.
 - g. Press "ENTER" to "LoCut".
This value = 0
 - h. Press "ENTER" to RUN MODE.

5. CONTROL PANEL SETUP (CONT.)

3. Setting Presets
 - a. Press "Pre A".
 - b. Press "PRGM"
This value = "High Amp Set Point".
Use arrow buttons to change value.
 - c. Press "ENTER".

4. Setting Relays
 - a. Press "PRGM" to "rELAYS".
 - b. Press "ENTER" to "HYS A".
 - c. Press "PRGM"
This value = "High Amp Set Point" - "Low Amp Set Point"
Use arrow buttons to change value.
 - d. Press "ENTER" to RUN MODE.

EXAMPLE: Full Load Running Amps = 21 Amps
High Amp Set Point = 20 Amps
Low Amp Set Point = 12 Amps

Then "HYS A" = 8 Amps (NOTE: This is the difference between the High Amp Set Point and the Low Amp Set Point. $[20 \text{ Amps} - 12 \text{ Amps} = 8 \text{ Amps}]$)
And "Pre A" = 20 Amps

C. Locking the Amp Meter

1. Locking the amp meter is not required, but does prevent the meter from being tampered with once it is programmed.
2. In RUN MODE press "LOCK" three (3) times within five (5) seconds.
This value = A number that is easily remembered.
Use arrow buttons to change value.
 - a. Press "ENTER".

D. Unlocking the Amp Meter

1. In RUN MODE press "LOCK" three (3) times within five (5) seconds.
 - a. Enter the "LoC" value.
Use arrow buttons to change value.
 - b. Press "ENTER".

NOTE

It is recommended to write down the "LoC" value and keep it in a safe place in case it is forgotten.

1. PERFORM PRE-START CHECKS

▲ DANGER

To ensure that the drive is not unexpectedly started, turn off and lock out or tag out the power source before proceeding. Failure to observe these precautions could result in series injury or death.

▲ DANGER

Failure to perform any or all of these pre-start checks may cause damage to the equipment and/or cause **SERIOUS INJURY** or **DEATH** to those in the work area.

Failure to perform any or all of these pre-start checks may also be a misuse of the equipment. Any misuse of the equipment may void the warranty.

- A. Make sure ALL shields are in place.

▲ WARNING

ALWAYS keep ALL guards and shields in place, until all the power is disconnected and locked out.

- B. Inspect the drive unit for any problems or potential problems.
- C. Be aware of any emergency shutdown procedures. Two (2) people must always be in a position where the operation of the equipment can be monitored.
- D. Before starting the auger for the first time, make sure that all parts are assembled correctly according to the instructions in this manual.

CAUTION

Be sure to remove the grain from the drive chain and sprockets. If this is not done, damage can occur to the drive system.

▲ DANGER

Keep all unqualified personnel out of work area before operating or moving the machine. Two (2) people must always be in a position where the operation of the equipment can be monitored from the **OUTSIDE** of the bin..

2. START THE AUGER

- A. Plug the two (2) motors, foot switch, and thermal protection cords into the bottom of the control panel while making sure they are locked into the receptacles. Each plug is different and can only be plugged into one (1) receptacle to prevent accidental electric shock and/or overloads.
- B. Step on the foot switch and press the "Start" button.

CAUTION

DO NOT start or stop the auger while it is under load.

- B. Run the auger through a "break-in" period, if it is being used for the first time or for the first time of the season.
- C. "Polish" the flighting by running the auger at partial capacity until it is smooth, before attempting full capacity.

CAUTION

Failures may occur if the auger is run full before it has been "polished" during the "break-in" period.

CAUTION

NEVER operate the auger empty. Operating augers empty for any length of time will cause excessive wear. NEVER operate the auger at speeds higher than recommended. Auger flight speed in excess of recommended speed causes excessive wear.

CAUTION

Be aware of any unusual vibration or noises during the initial start-up and "break-in" period. If anything unusual is detected, immediately shutdown the auger, and disconnect and lockout the power supply before servicing.

1. OPERATING THE SWEEP AUGER

▲ DANGER

Danger! Keep out of the bin while the bin sweep auger is in operation. The rapidly moving sweep auger can cause **SERIOUS INJURY** or **DEATH!**

CAUTION

Gear Reducer is shipped without oil. Add the proper amount of the recommended lubricant before operating. Failure to observe these precautions could result in damage to, or destruction of, the equipment.

NOTE

The auger capacity can fluctuate greatly under varying conditions. Moisture content, different commodities, amount of foreign matter, and speeds all play a part in the performance of the auger. Twenty-five percent (25%) moisture may cut capacity by as much as 40% under some conditions.

- A. Make certain there are at least two (2) people in the work area to monitor operations at all times.
- B. Start the bin unloading equipment before starting the bin sweep auger.

CAUTION

Be alert for any unusual vibrations, noises, and the loosening of any fasteners. If anything unusual is detected, immediately shutdown the auger, disconnect and lockout the power source before servicing.

- C. Shutdown the auger as soon as the bin is empty.
- D. Consideration should be given to the proper size auger for any intermittent type operations. When augers are stopped and restarted under full load, it may result in damage to the auger. Using a larger diameter auger and reducing its load level will be far better than subjecting a smaller diameter auger to big loads. If an auger is kept from absolute filling, it will make start-up easier and will convey more efficiently.

1. OPERATING THE SWEEP AUGER (cont.)

NEVER enter the bin while the bin sweep is in operation.

NEVER attempt to control the operation of the bin sweep by depressing the operating controls with shovels, brooms or any other objects.

⚠ DANGER

DO NOT attempt to restrain movement of the bin sweep with ropes, bars or other devices.

NEVER allow an operator to attempt to manually restrain the bin sweep.

2. OPERATING THE SWEEP AUGER CONTROL PANEL

A. The sweep operates in two (2) different "modes".

1. Automatic (The auger motor runs and the drive motor runs using the Amp Meter in the control panel.)

Step on the footswitch and press the "Start" button. The auger motor will turn on and the drive motor will turn on only if the Amp Meter reaches the "Low" set point.

2. Manual (Overrides the Amp Meter and allows the operator to manually move the sweep.)
 - a. Idle (Allows the auger motor to run, but does not move the sweep forward or reverse.)
 - b. Forward (Auger motor will run and moves the sweep towards the grain.)
 - c. Reverse (Stops the auger motor and moves the sweep away from the grain.)

Step on the footswitch and press the "Start" button. The auger motor will turn, but the sweep will not move. Turn the "Manual" switch to "Forward" and the sweep will move forward towards the grain. Turn the "Manual" switch to "Reverse" and the auger motor will shut off and move the sweep backwards away from the grain.

The "Start" button **MUST** be pressed to start the auger motor again.

NOTE

The footswitch **MUST** be depressed and the thermal protection cord plugged in before the sweep will operate.

1. NORMAL SHUTDOWN

- A. Before shutting down the unit, be sure the sumps and unload conveyor are empty.
- B. Press the “Stop” button on the control panel.

2. EMERGENCY SHUTDOWN

- A. Know how to shutdown the auger in case of an emergency.
- B. Step off the footswitch and press the “Stop” button.
- C. Disconnect and lockout the power source.

CAUTION

NEVER start the equipment under load. Doing so may cause damage. This type of damage is considered a misuse of the equipment. Any misuse of the equipment may void the warranty.

3. STORAGE PREPARATION

- A. Be sure the sumps and unload conveyor are empty.
- B. Close the sump control gates.
- C. Park the sweep behind the intermediate sumps, so that the sumps are on the auger side of the sweep.
- D. Shutdown the auger.
- E. Make sure all fasteners are tight.
- F. Cover the motors with the tarps supplied with the sweep after first allowing the motors to cool down.
- G. Place blocks under the frame of the sweep to help support the sweep during storage.

1. MAINTAIN THE AUGER



ALWAYS shutdown and disconnect the power supply before adjusting, servicing or cleaning the equipment.

- A. Use caution when repairing or replacing equipment parts.
- B. Make sure ALL decals are legible and tightly attached to the auger. If necessary, replace them **FREE OF CHARGE** by contacting GSI at:

GSI
P.O. Box 20
1004 E. Illinois St.
Assumption, IL 62510
(217) 226-4421

- C. Ensure that ALL electric motors, etc. are operating at the proper speed.
- D. Make sure ALL electrical wiring is not damaged, and that it meets proper wiring codes.
- E. Make sure ALL components are in good working condition before use.

1. CONTROL PANEL SCHEMATIC (460/3/60)

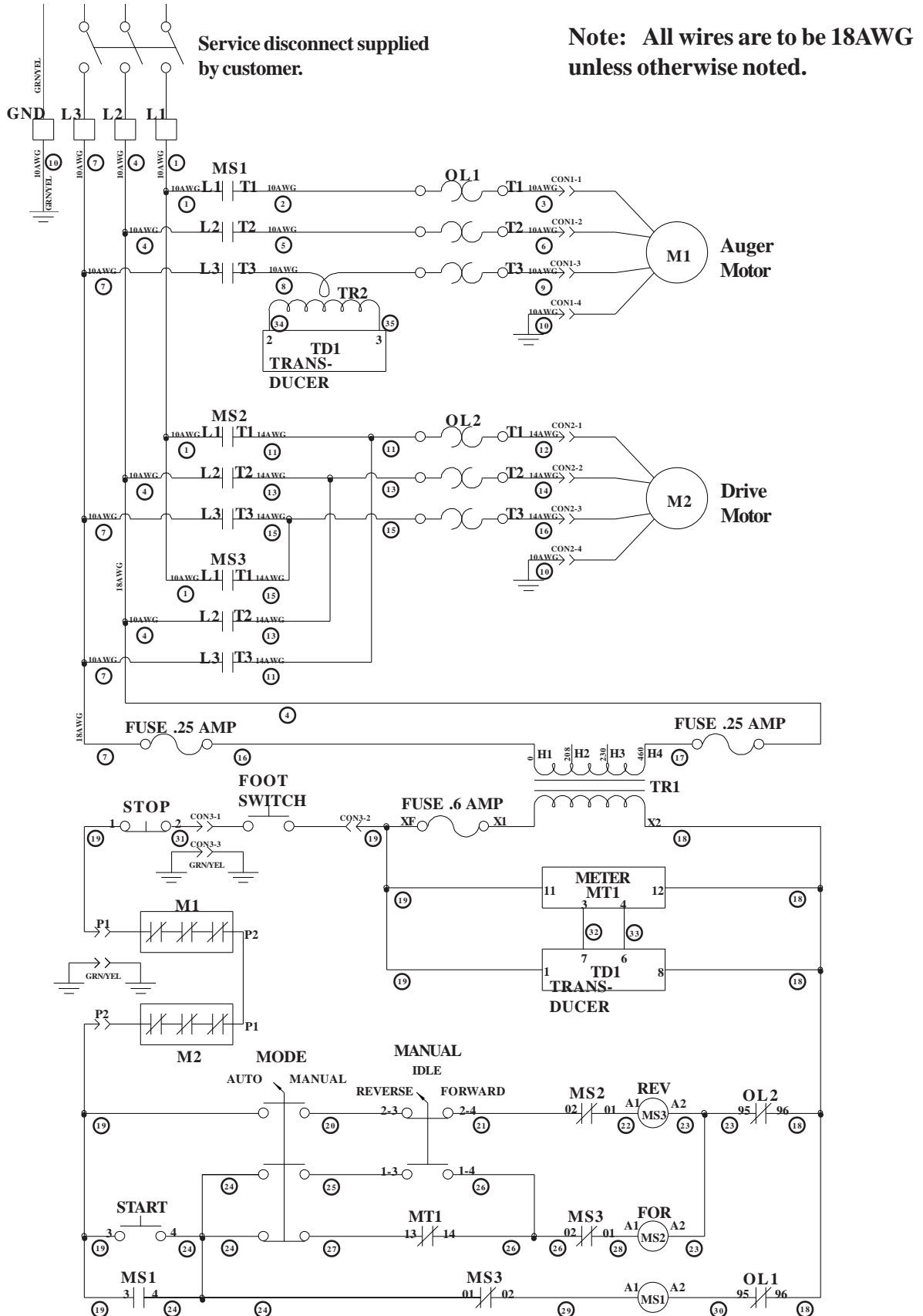

Control Panel Diagrams

2. CONTROL PANEL SCHEMATIC (230/3/60)

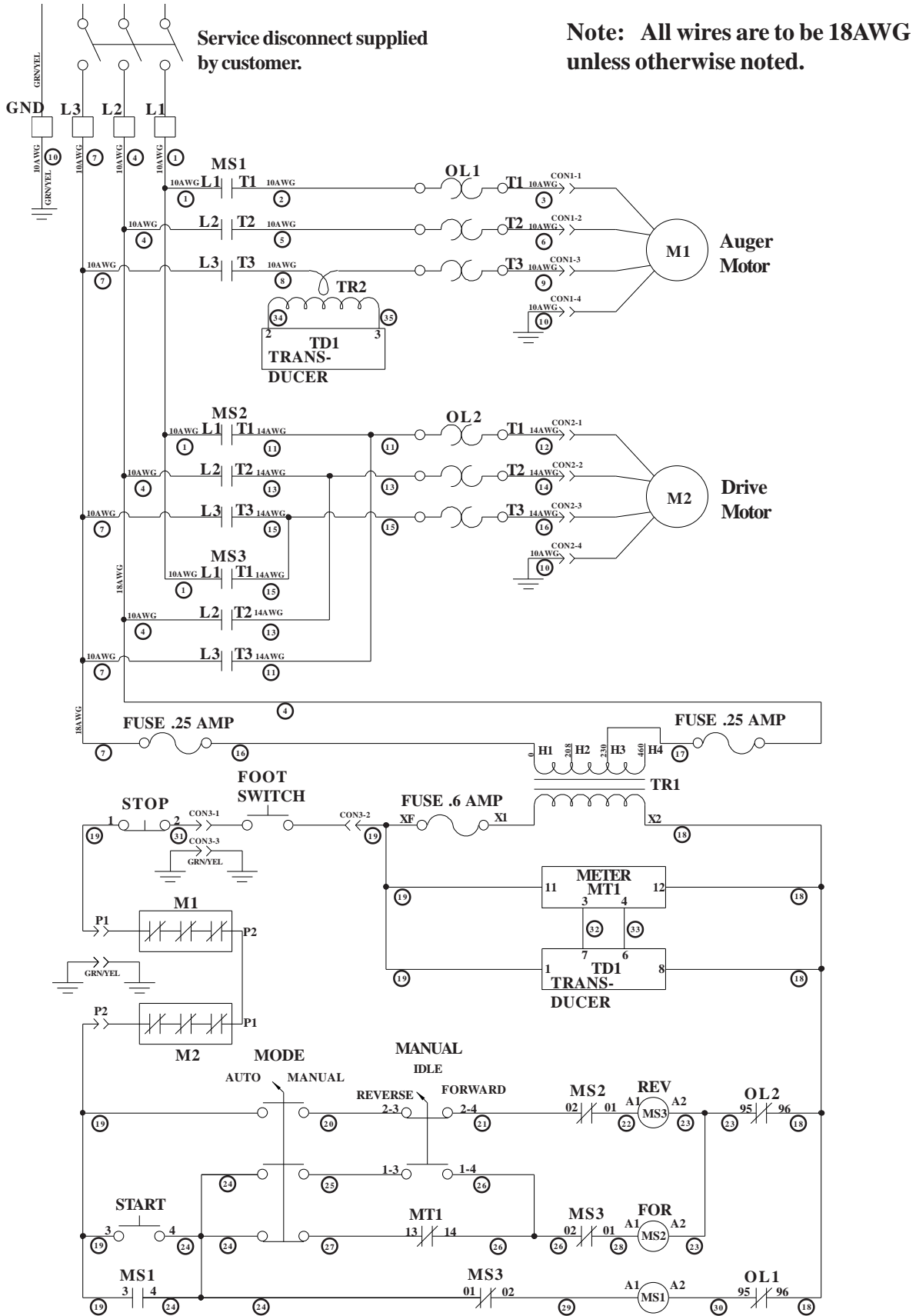

3. CONTROL PANEL SCHEMATIC (380/3/50)

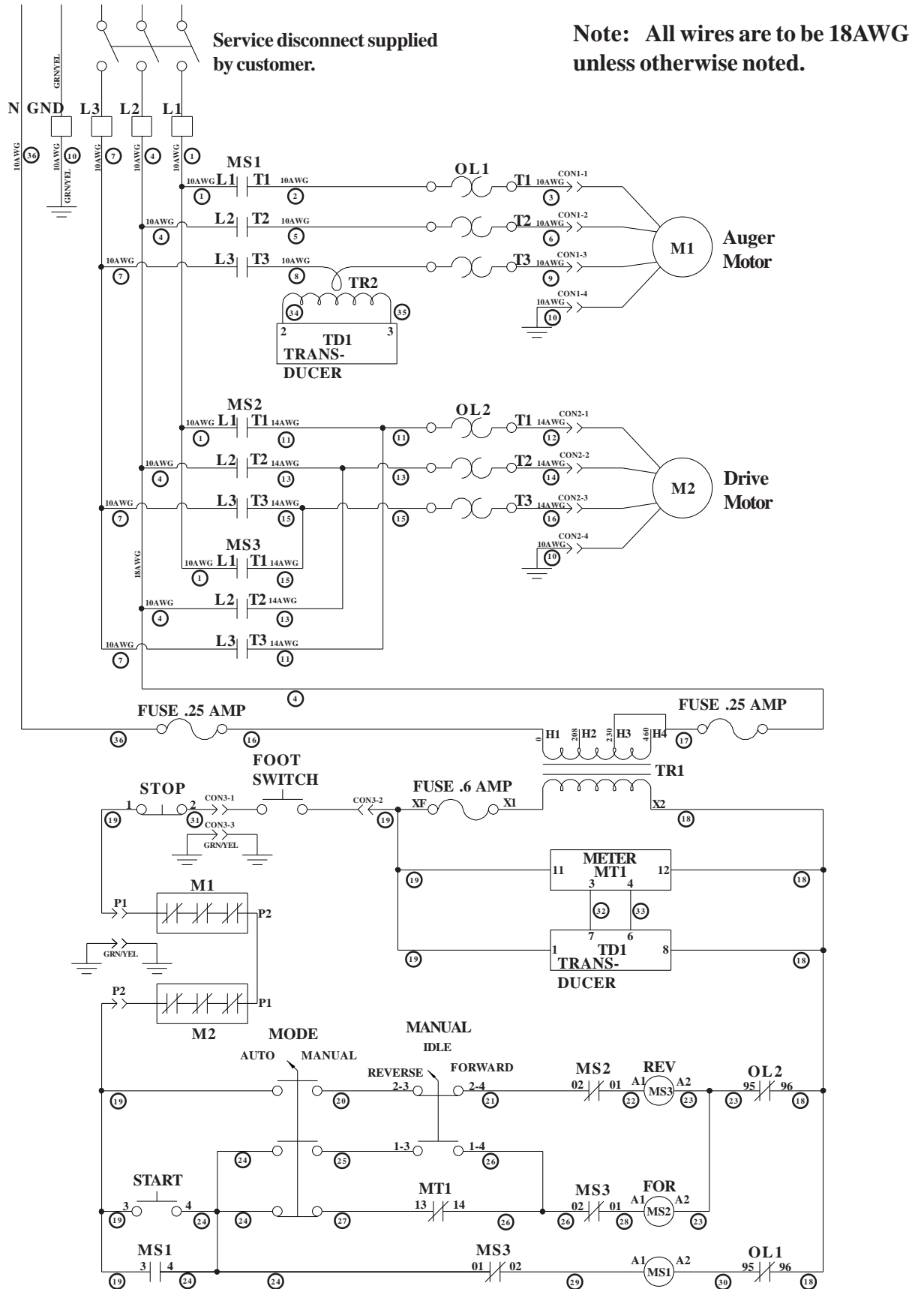

Problem	Possible Cause	Solution
1 Sweep will not run.	<ul style="list-style-type: none"> a.) Power cords may be unplugged. b.) Foot switch may not be actuated. c.) Overloads may be tripped. d.) Adjustable overloads not set correctly 	<ul style="list-style-type: none"> a.) Plug in the power cords. b.) Make sure the foot switch is depressed and the switch is operating properly. c.) Reset the overloads. d.) Set overload to value listed on motor name plate for Full Load Amps.
2 Low capacity.	<ul style="list-style-type: none"> a.) The auger may not be fully loaded. b.) The auger is moving too slowly. 	<ul style="list-style-type: none"> a.) Make sure the grain is flowing into the auger, making it fully loaded. b.) Check the auger speed. Low capacity will result from speeds slower than recommended.
3 Sweep will not move around the bin.	<ul style="list-style-type: none"> a.) The control panel may not be in "Automatic Mode". b.) The amp meter is not properly adjusted. c.) The drive chain may be broken. 	<ul style="list-style-type: none"> a.) Turn the switch to "Automatic Mode". b.) Set the amp meter so the running amps of the auger motor will turn on the drive motor. c.) Repair the drive chain.
4 The sweep is vibrating.	<ul style="list-style-type: none"> a.) The auger may have foreign materials in it. b.) The hanger bearings may be worn. c.) The flight connections may be loose. d.) The flighting may be worn. 	<ul style="list-style-type: none"> a.) Remove the foreign material. b.) Replace the hanger bearing. c.) Tighten all of the flight connecting bolts. d.) Replace all the flighting sections that are worn.

CONTROL PANEL COMPONENTS

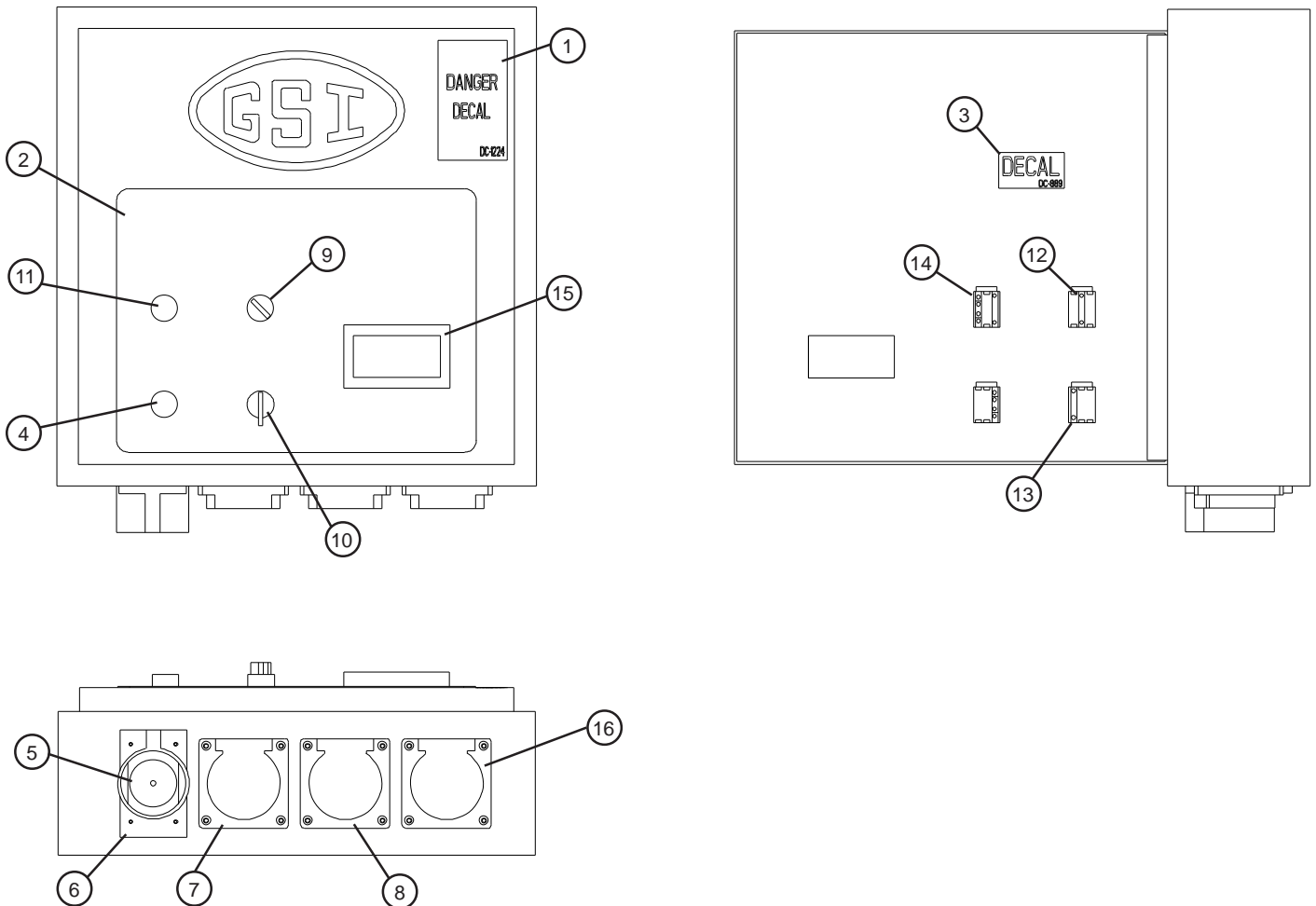

Ref. #	Part #	Description
1	DC-1224	Decal, DANGER! Hi Voltage
2	DC-1536	Decal, Series 2 Sweep Panel Overlay
3	DC-889	Decal, DANGER! Hi Voltage
4	GC03659	Std-Round-Push Button-Plastic-Flush-Red
5	GC03666	Hubbell Locking Receptacle - 3-Pole 4-Wire 50 Amps 480 Voltage
6	GC03667	Hubbell Wdl Open Lift Cover
N/S	GC03668	Hubbell Locking Plug - 3-Pole 4-Wire 50 Amps 480 Voltage
7	GC03669	Hubbell Locking Receptacle - Nema L16-20R
N/S	GC03670	Hubbell Locking Plug - Nema L16-20P
8	GC06954	Hubbell Locking Receptacle - Nema L7-20R
9	GC06956	2 Position - Maint - Plastic - Black
10	GC06957	3 Position - Lever - SL - Sw - Momentary
11	GC06958	Std-Round-Push Button-Plastic-Flush-Green
12	GC06959	Cnt Blck/1NO/SCR
13	GC06960	Cnt Blck/1NC/SCR
14	GC06961	Cnt Blck/SCR
15	GC07585	Series 2 Sweep Amp Meter
16	GC03671	Hubbell Locking Receptacle - Nema L5-20R
N/S	GC03672	Hubbell Locking Plug - Nema L5-20P
N/S	GC06857	Series 2 Sweep Safety Footswitch Assembly

QUICK DETACH CONTROL PANEL ASSEMBLY (GC10115)

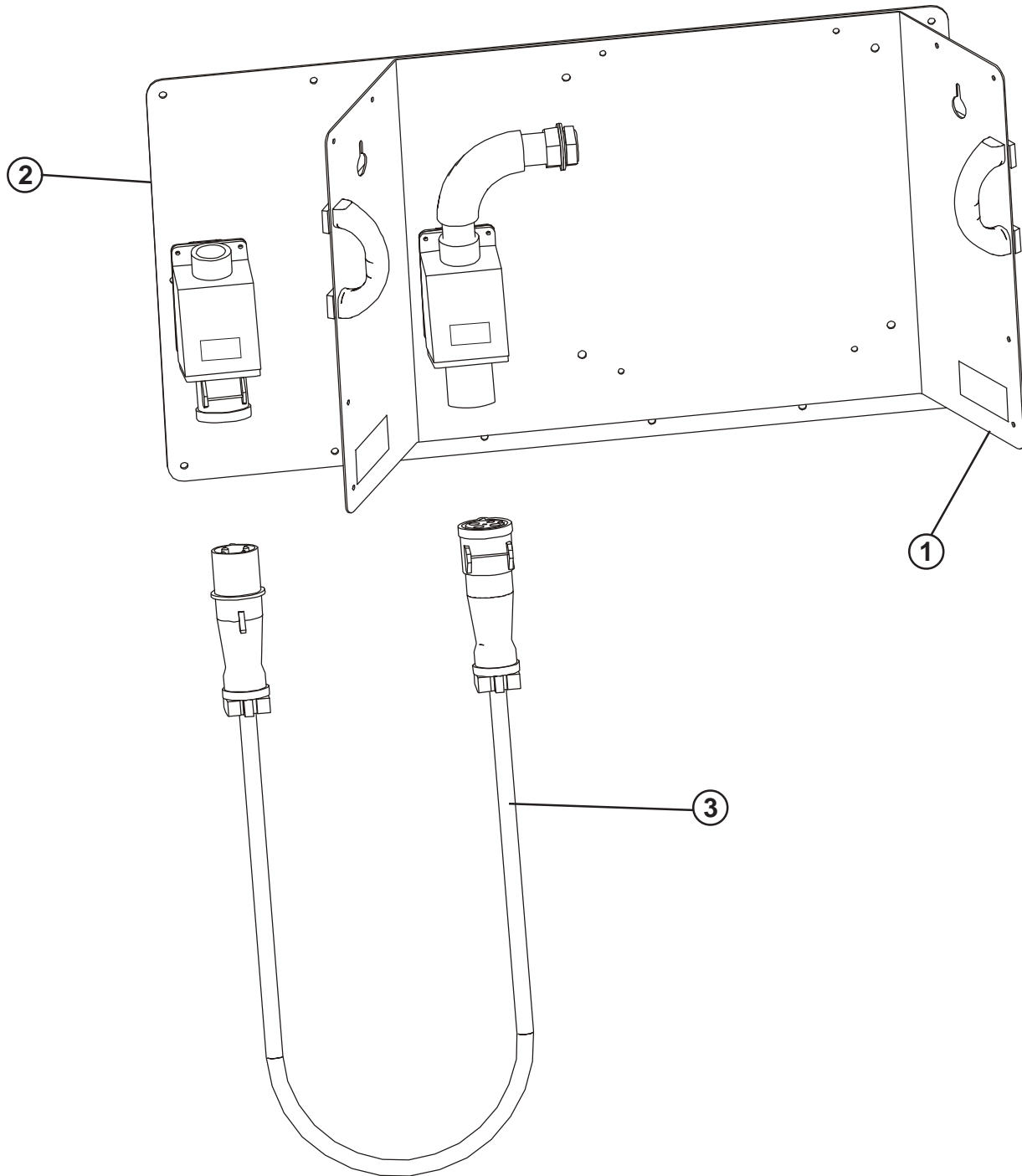

Component Parts

Ref #	Part #	Qty	Description
1	GC10109	1	Control Box Base
2	GC10116	1	Dock Station Assembly
3	GC10079	1	Drop Cord

CONTROL BOX BASE (GC10109) (for quick detach control panel)

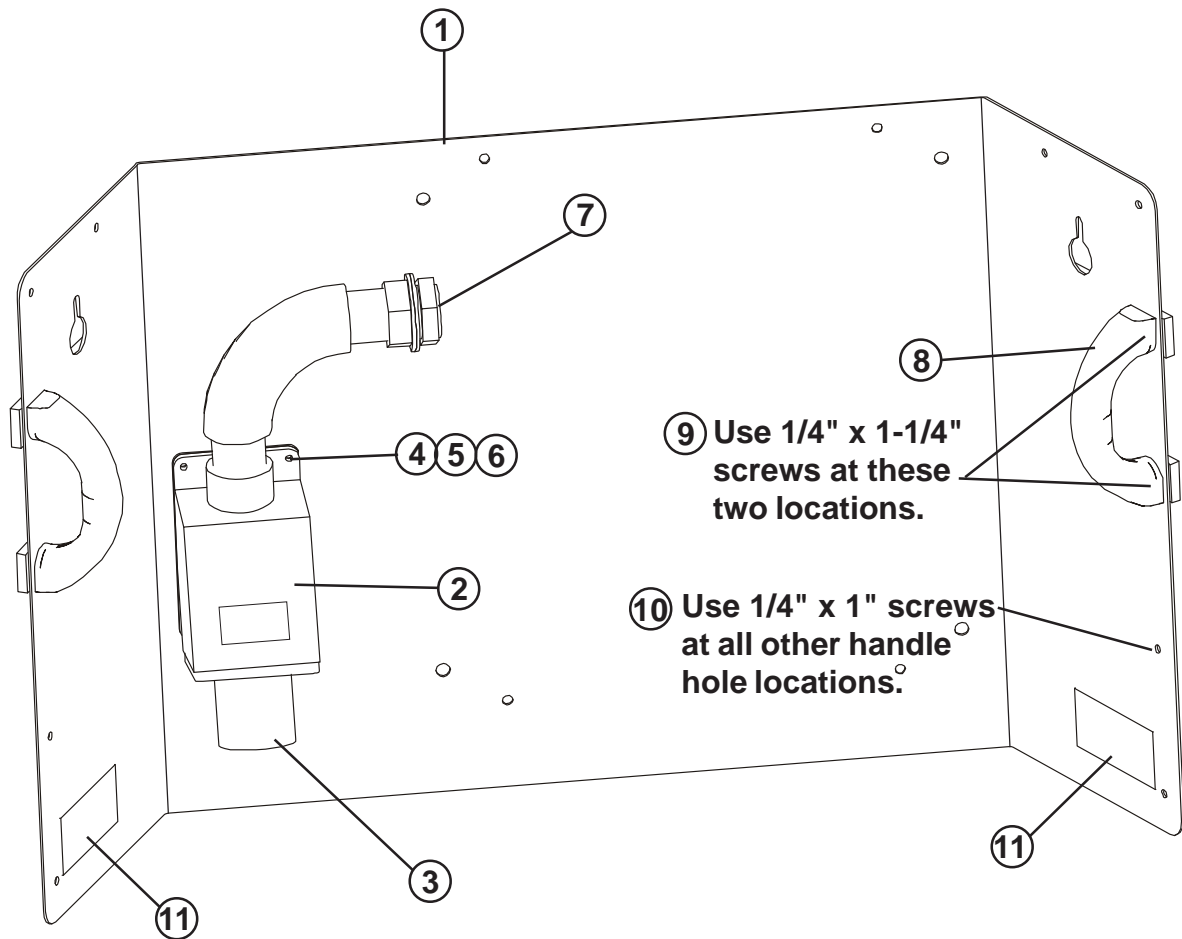

Component Parts

Ref #	Part #	Qty	Description
1	GC10107	1	Base Back Plate Weldment
2	GC10071	1	Back Box
3	GC10073	1	Inlet
4	S-6998	3	Cap Screw 1/4-20 x 1" Zn Gr5
5	S-2041	3	Washer, Split Lock 1/4 Zn
6	S-1120	3	Nut, Hex 1/4-20 Zn
7	GC10113	1	Conduit Assembly
8	F-7050	2	Handle
9	S-9315	4	Screw for Handle 1/4-14 x 1 1/4" Long
10	S-8166	4	Screw for Handle 1/4-14 x 1" Long
11	DC-1756	2	Decal, Warning Lifting Hazard
N/S	GC10224	3	Wire, 6 ga x 2' lg Stranded, Black
N/S	GC10225	1	Wire, 6 ga x 2' lg Stranded THHN, Green
N/S	E160-1137	1	Electrical Grounding Lug #TA-2 (CSA)

DOCK STATION (GC10116) (for quick detach control panel)

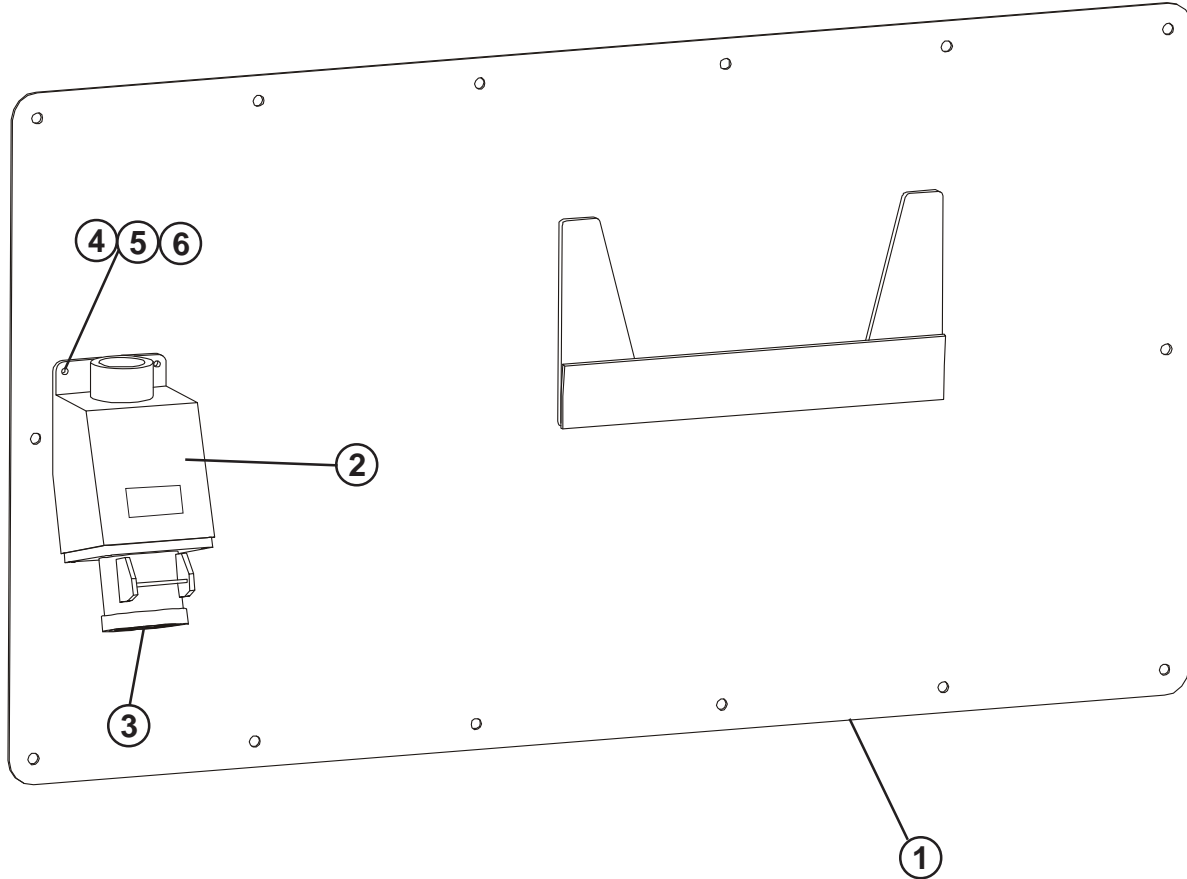

Component Parts

Ref #	Part #	Qty	Description
1	GC10103	1	Base Weldment
2	GC10071	1	Back Box
3	GC10072	1	Receptacle
4	S-6998	3	Cap Screw 1/4-20 x 1" Zn Gr5
5	S-2041	3	Washer, Split Lock 1/4 Zn
6	S-1120	3	Nut, Hex 1/4-20 Zn

CONDUIT ASSEMBLY (GC10113) (for quick detach control panel)

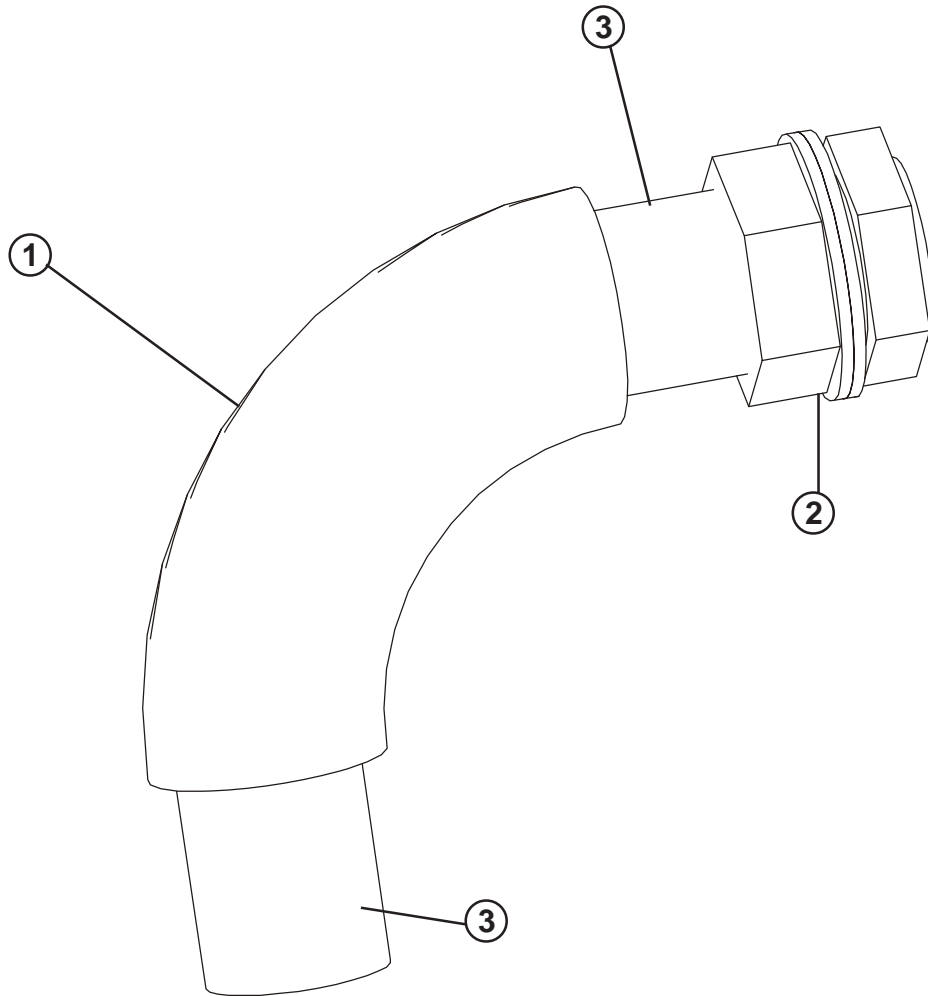

Component Parts

Ref #	Part #	Qty	Description
1	GC10111	1	Elbow-1 1/2 Conduit
2	GC10110	1	Hub-1 1/2 Conduit
3	GC10112	2	Nipple-1 1/2 Conduit

DROP CORD (GC10079) (for quick detach control panel)

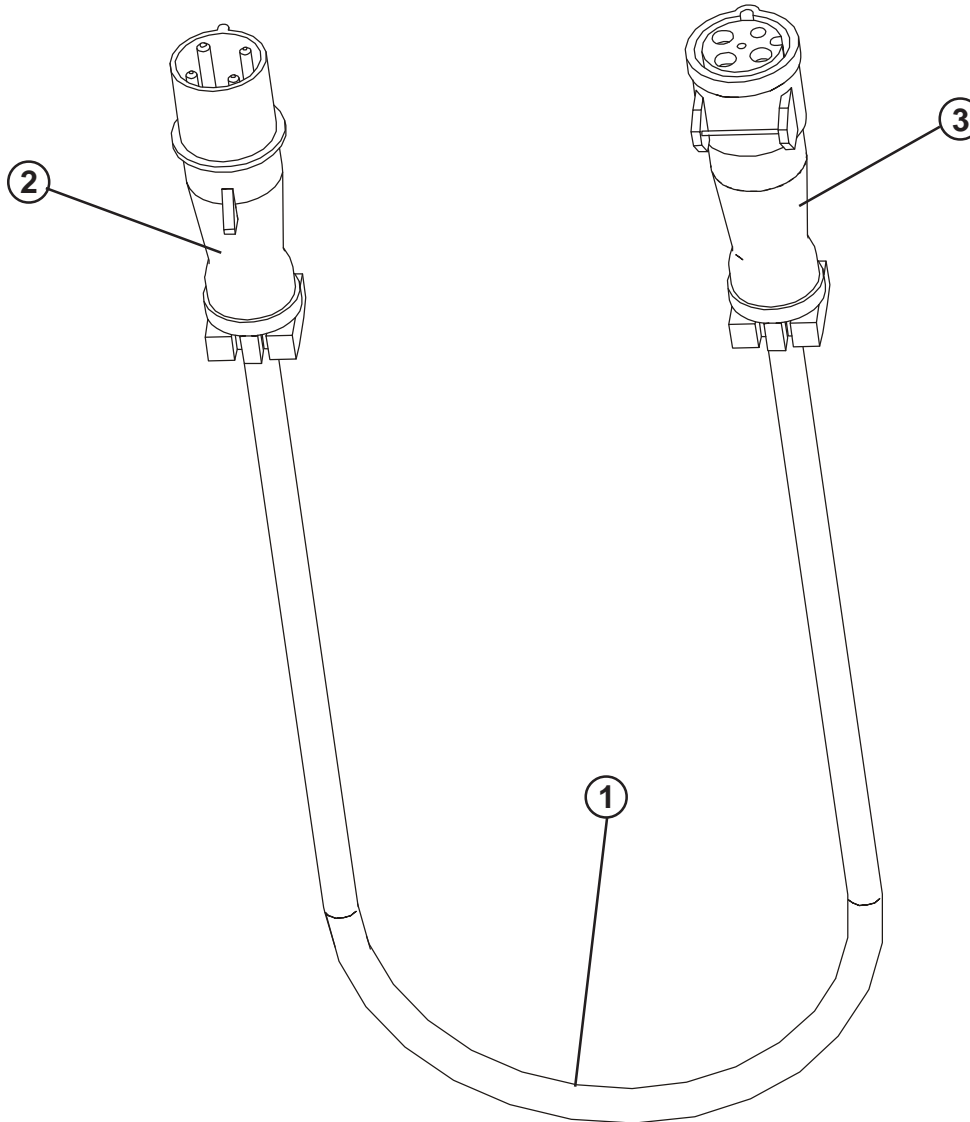

Component Parts

Ref #	Part #	Qty	Description
1	GC10078	1	Cable
2	GC10074	1	Plug, Male
3	GC10075	1	Plug, Female

The GSI Group, Inc. Warranty

THE GSI GROUP, INC. ("GSI") WARRANTS ALL PRODUCTS WHICH IT MANUFACTURES TO BE FREE OF DEFECTS IN MATERIAL AND WORKMANSHIP UNDER NORMAL USAGE AND CONDITIONS FOR A PERIOD OF 12 MONTHS AFTER RETAIL SALE TO THE ORIGINAL END USER. THE PURCHASER'S SOLE REMEDY AND GSI'S ONLY OBLIGATION SHALL BE TO REPAIR OR REPLACE, AT GSI'S OPTION AND EXPENSE, PRODUCTS THAT, IN GSI'S SOLE JUDGMENT, CONTAIN A MATERIAL DEFECT DUE TO MATERIALS OR WORKMANSHIP. ALL DELIVERY AND SHIPMENT CHARGES TO AND FROM GSI'S FACTORY WILL BE PURCHASER'S RESPONSIBILITY. EXPENSES INCURRED BY OR ON BEHALF OF THE PURCHASER WITHOUT PRIOR WRITTEN AUTHORIZATION FROM AN AUTHORIZED EMPLOYEE OF GSI SHALL BE THE SOLE RESPONSIBILITY OF THE PURCHASER.

EXCEPT FOR THE LIMITED WARRANTY EXPRESSED ABOVE, GSI MAKES NO FURTHER WARRANTY OF ANY KIND, EXPRESS OR IMPLIED, INCLUDING, WITHOUT LIMITATION, WARRANTIES OF MERCHANTABILITY OR FITNESS FOR A PARTICULAR PURPOSE OR USE IN CONNECTION WITH (I) PRODUCT MANUFACTURED OR SOLD BY GSI OR (ii) ANY ADVICE, INSTRUCTION, RECOMMENDATION OR SUGGESTION PROVIDED BY AN AGENT, REPRESENTATIVE OR EMPLOYEE OF GSI REGARDING OR RELATED TO THE CONFIGURATION, INSTALLATION, LAYOUT, SUITABILITY FOR A PARTICULAR PURPOSE, OR DESIGN OF SUCH PRODUCTS.

GSI SHALL NOT BE LIABLE FOR ANY DIRECT, INDIRECT, INCIDENTAL OR CONSEQUENTIAL DAMAGES, INCLUDING, WITHOUT LIMITATION, LOSS OF ANTICIPATED PROFITS OR BENEFITS. PURCHASER'S SOLE AND EXCLUSIVE REMEDY IS AS SET FORTH IN THE LIMITED WARRANTY EXPRESSED ABOVE, WHICH SHALL NOT EXCEED THE AMOUNT PAID FOR THE PRODUCT PURCHASED. THIS WARRANTY IS NOT TRANSFERABLE AND APPLIES ONLY TO THE ORIGINAL PURCHASER. GSI SHALL HAVE NO OBLIGATION OR RESPONSIBILITY FOR ANY REPRESENTATIONS OR WARRANTIES MADE BY OR ON BEHALF OF ANY DEALER, AGENT OR DISTRIBUTOR OF GSI.

GSI ASSUMES NO RESPONSIBILITY FOR CLAIMS RESULTING FROM ERECTION DEFECTS OR UNAUTHORIZED MODIFICATIONS TO PRODUCTS WHICH IT MANUFACTURED. MODIFICATIONS TO PRODUCTS NOT SPECIFICALLY DELINEATED IN THE MANUAL ACCOMPANYING THE EQUIPMENT AT INITIAL SALE WILL NULLIFY THE PRODUCT WARRANTY THAT MIGHT HAVE BEEN OTHERWISE AVAILABLE.

THE FOREGOING WARRANTY SHALL NOT EXTEND TO PRODUCTS OR PARTS WHICH HAVE BEEN DAMAGED BY NEGLIGENT USE, MISUSE, ALTERATION OR ACCIDENT. THIS WARRANTY EXTENDS SOLELY TO ONLY PRODUCTS MANUFACTURED BY GSI. THIS WARRANTY IS EXCLUSIVE AND IN LIEU OF ALL OTHER WARRANTIES EXPRESS OR IMPLIED. GSI RESERVES THE RIGHT TO MAKE DESIGN OR SPECIFICATION CHANGES AT ANY TIME.

PRIOR TO INSTALLATION, PURCHASER HAS THE RESPONSIBILITY TO COMPLY WITH ALL FEDERAL, STATE AND LOCAL CODES WHICH MAY APPLY TO THE LOCATION AND INSTALLATION OF PRODUCTS MANUFACTURED OR SOLD BY GSI.

THIS EQUIPMENT SHALL BE INSTALLED IN ACCORDANCE WITH THE CURRENT INSTALLATION CODES AND APPLICABLE REGULATIONS WHICH SHOULD BE CAREFULLY FOLLOWED IN ALL CASES. AUTHORITIES HAVING JURISDICTION SHOULD BE CONSULTED BEFORE INSTALLATIONS ARE MADE.



P.O. Box 20
1004 E. IL. St
Assumption IL. 62510
(217) 226-4421
(217) 226-4429
