

1 9 9 5

INSTALLATION AND DRYER TOWING



PNEG-338
ALL PORTABLE
SINGLE MODULE
DRYER MODELS

AIRSTREAM
a member of
THE GSI GROUP



GET A FREE HAT FROM AIRSTREAM

Receive a *free* embroidered baseball cap.
And all you have to do is *send in* the postage paid warranty
registration card below.



- Fill out the card below. All information must be complete in order to make the warranty on your purchase effective.
- Additional hats may be purchased.
- Complete only one registration card per dryer installation.
- Mail the postage paid card within ten days of dryer installation.

AIRSTREAM
a member of
THE GSI GROUP



PLEASE PRINT CLEARLY

Name _____
Address _____
City _____
State _____ Zip _____
Phone _____

Name of Dealer _____
Name of Salesman _____
City _____
Name of Installer _____
City _____
Installation Date _____

Dryer Model No. _____
Dryer Serial No. _____

Type of Installation:

Farm
 Commercial
 Other _____

Grains dried _____
Bushels dried per year _____

Please send my free hat
 Please send _____ additional hats (\$4.55 each)
Enclosed is \$ _____

I acknowledge that I have read the operator's manual and I am aware of the operating procedures, safety precautions, and warranty. I therefore request that my warranty be validated.

Dealer's or Representative's Signature Date

Customer's Signature Date

DON'T FORGET

Receive a *free* embroidered baseball cap.
And all you have to do is *send in* the postage paid warranty
registration card below.

Name _____
Address _____
City _____ State _____ Zip _____



NO POSTAGE
NECESSARY
IF MAILED
IN THE
UNITED STATES

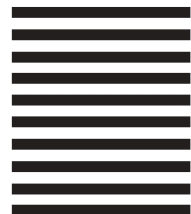

POSTAGE WILL BE PAID BY ADDRESSEE:

Grain Systems, Inc.
Airstream Grain Dryer Service Department
1004 East Illinois Street
Assumption, IL 62510-0020



INSTALLATION AND DRYER TOWING

TABLE OF CONTENTS

Warranty.....	6
Safety First.....	7
Safety Alert Decals.....	8
Safety Precautions.....	9
Safety Sign-Off Sheet.....	10
Transporting The Dryer.....	11
Installation.....	12
Foundation Lay-Out Typical Of Dryer Line.....	14
Foundation Specifications For Dryers.....	15
Assembly Instructions For Wet Bin & Top Auger.....	16
Assembly Instructions Diagram.....	17
Fuel Connection.....	18
Electrical Power Supply.....	21
Electrical Load Information.....	23

INSTALLATION AND DRYER TOWING

Thank you for choosing an Airstream Grain Dryer. This dryer is one of the finest ever built. It is designed to give excellent performance and service for many years.

This manual describes the towing and installation for all Competitor series, 1100 series single fan, 1200 series two fan, and 1300 series three fan grain dryers.

These models are available for liquid propane or natural gas fuel supply, with either single phase 230 volt, or three phase 220 or 440 volt electrical power.

WARRANTY

Grain Systems, Inc. warrants its products to be free of defects in material and workmanship. The only obligation of the manufacturer is to repair or replace components which have been submitted and found to be defective within 24 months after installation. If so found to be defective, the components will be repaired or replaced without charge, this constituting and entirely fulfilling the warranty obligation. Grain Systems, Inc. assumes no liability for expenses incurred without written authorizations; in no event shall liabil-

ity include special or consequential damages, or exceed the selling price of the product.

This warranty does not cover products or parts which have been damaged by negligent use, misuse, alteration or accident. Electric motors, tires, and other components supplied by outside manufacturers have separate warranties, from those suppliers. This warranty is exclusive and in lieu of all other warranties, expressed or implied. Grain Systems, Inc. reserves the right to make design or specification

changes at any time, without any contingent obligations to purchasers of products already sold.

All instructions shall be construed as recommendation only. Because of the many variable conditions in actual installation, Grain Systems, Inc. assumes no liability for results arising from the use of such recommendations. Any alteration in design or operation of any Grain Systems, Inc. product must be submitted and approved in writing by Grain Systems, Inc. before the alteration is made.

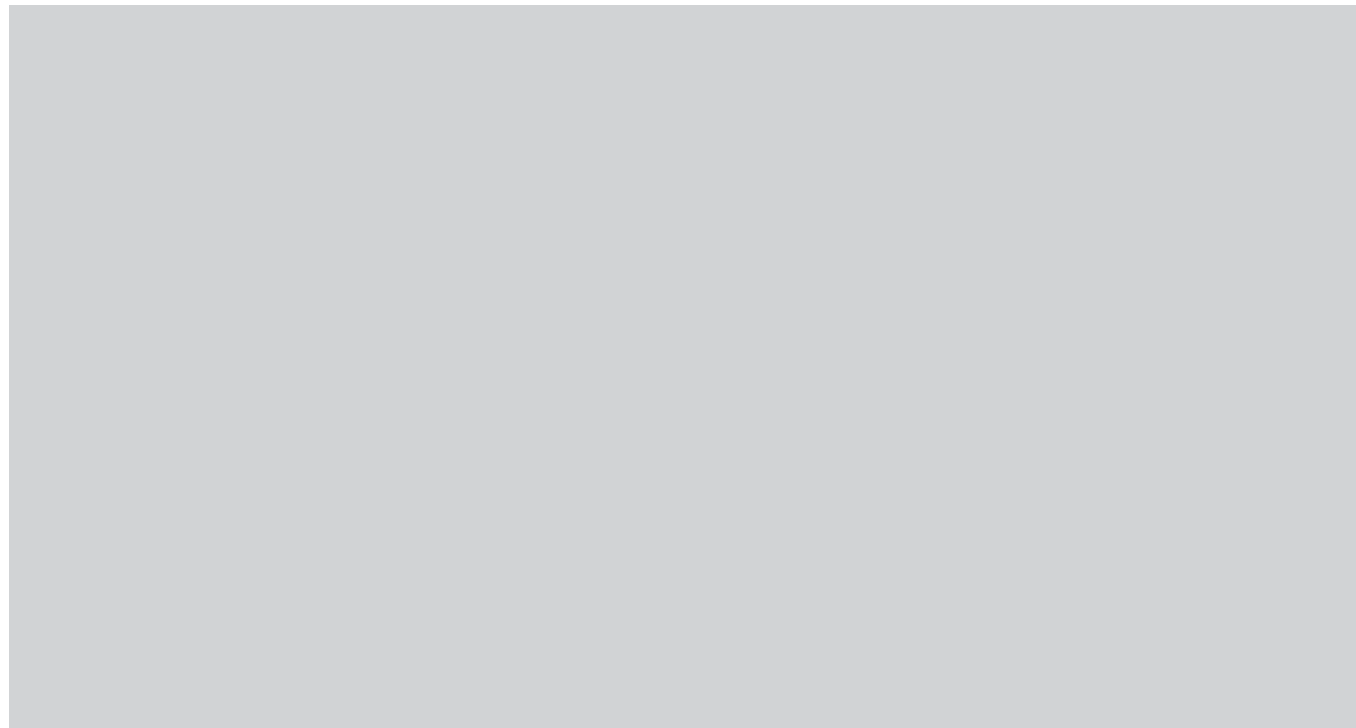

The towing driver checks his rear lights (not provided by GSI) on an Airstream 1226 dryer before beginning travel.

SAFETY FIRST

Grain Systems, Inc.'s principle concern is your safety and the safety of others associated with grain handling equipment. This manual is written to help you understand safe operating procedures, and some of the

problems that may be encountered by the operator or other personnel.

As owner and/or operator, it is your responsibility to know what requirements, hazards and precautions exist, and to inform all person-

nel associated with the equipment or who are in the area. Avoid any alterations to the equipment. Such alterations may produce a very dangerous situation, where serious injury or death may occur.

SAFETY ALERT SYMBOL

The symbol shown is used to call your attention to instructions concerning your personal safety. Watch for this symbol; it points out important safety precautions. It means "ATTENTION", "WARNING", "CAUTION", and "DANGER". Read the message and be cautious to the possibility of personal injury or death.



WARNING! BE ALERT!

Personnel operating or working around a dryer should read this manual. This manual must be delivered with equipment to its owner. Failure to read this manual and its safety instructions is a misuse of the equipment.

SAFETY ALERT DECALS

Grain Systems, Inc. recommends that you contact your local power company and have a representative survey your installation so your wiring will be compatible with their system, and you will have adequate power supplied to your unit.



Safety decals should be read and understood by all people in and around the dryer area. If the following safety decals are not displayed on your dryer, or if they are damaged, contact Grain Systems, Inc. for replacement.

A CAREFUL OPERATOR IS THE BEST INSURANCE AGAINST AN ACCIDENT



SAFETY ALERT DECALS

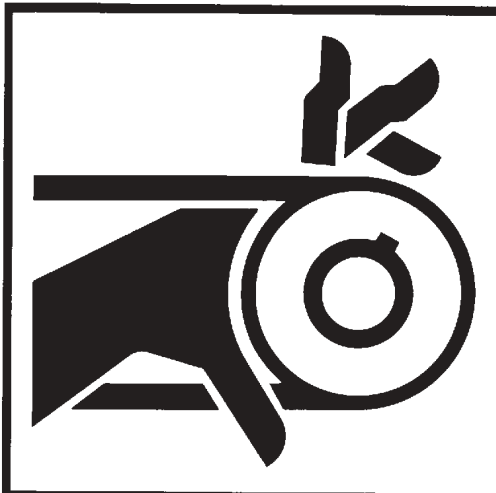

! DANGER

Automatically controlled belt drive can start at any time. Keep hands clear. Failure to do so could result in serious injury or death.

DC-386

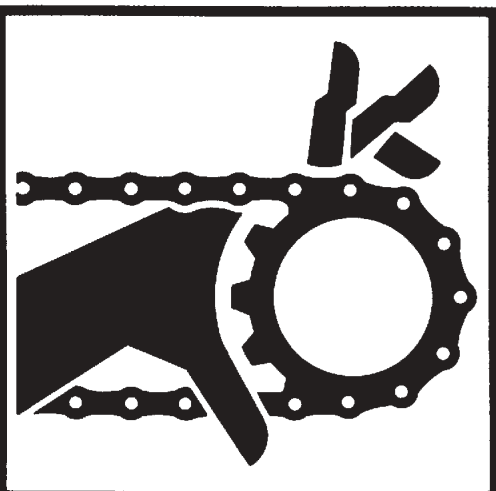

! DANGER

Do not operate without shields in place. Before removing any shield, disconnect main power supply and allow all moving parts to stop. Replace shields securely before restarting unit. Failure to do so could result in serious injury or death.

DC-385



! DANGER

Automatic equipment can start at any time. Do not enter until fuel is shut off and electrical power is locked in off position. Failure to do so will result in serious injury or death.

DC-384

Three decals displayed on all Airstream Dryers. Belt drives, chain driven meter rolls and combustible fuels must be treated with caution.

SAFETY PRECAUTIONS

1. Read and understand the operating manual before trying to operate the dryer.
2. Never operate the dryer while the guards are removed.
3. Power supply should be OFF for service of electrical components. Use CAUTION in checking voltage or other procedures requiring power to be ON.
4. Check for gas leaks at all gas pipe connections. If any leaks are detected, do not operate dryer. Shut down and repair before further operation.
5. Never attempt to operate the dryer by jumping or otherwise bypassing any safety devices on the unit.
6. Set pressure regulator to avoid excessive gas pressure applied to burner during ignition and when burner is in operation. Do not exceed maximum recommended drying temperature.
7. Keep the dryer clean. Do not allow fine material to accumulate in the plenum chamber.
8. Keep auger drive belts tight enough to prevent slippage.
9. Use CAUTION in working around high speed fans, gas burners, augers and auxiliary conveyors which can all START AUTOMATICALLY.
10. Do not operate in any area where combustible material will be drawn into the fan.
11. Before attempting to remove and reinstall any propeller, make certain to read the recommended procedure listed within the servicing section of the manual.
12. Be certain that capacities of auxiliary conveyors are matched to dryer auger capacities.
13. Clean grain is easier to dry. Fine material increases resistance to airflow and requires removal of extra moisture.

**READ THESE INSTRUCTIONS
BEFORE INSTALLATION AND OPERATION**

SAVE FOR FUTURE REFERENCE

USE CAUTION IN THE OPERATION OF THIS EQUIPMENT

The design and manufacture of this dryer is directed toward operator safety. However, the very nature of a grain dryer having a gas burner, high voltage electrical equipment and high speed rotating parts, does present a hazard to personnel which can not be completely safeguarded against, without interfering with efficient operation and reasonable access to components.

Use extreme caution in working around high speed fans, gas-fired heaters, augers and auxiliary conveyors, which may start without warning when the dryer is operating on automatic control.

**KEEP THE DRYER CLEAN
DO NOT ALLOW FINE
MATERIAL TO ACCUMULATE
IN THE PLENUM CHAMBER
OR SURROUNDING THE
OUTSIDE OF THE DRYER**

Continued safe, dependable operation of automatic equipment depends, to a great degree, upon the owner. For a safe and dependable drying system, follow the recommendations within this manual, and make it a practice to regularly inspect the operation of the unit for any developing problems or unsafe conditions.

Take special note of the safety precautions listed above before attempting to operate the dryer.

TRANSPORTING THE DRYER

The dryer is available with an optional transport kit for transporting the unit by truck or tractor. Make certain to observe the following safety precautions.

1. Recommended towing hitch height 14-17 inches. (Figure 1)
2. Hitch bolt to be *not less than 3/4 inch* in diameter and securely fastened with a locking nut, so it will not come out in travel and hitch will not bend. (Figure 2)
3. Minimize vertical hitch play with washers. (Figure 2)
4. Use safety chain. (Figure 1)
5. Dryer must be towed empty and in accordance with applicable state or provincial regulations. Dryer must never be towed with grain or other material in it.
6. Recommended tire pressures 55-60 P. S. I. (cold)
7. Maximum towing speed is 45 miles per hour or speed limit, whichever is lower.
8. After the first 50 miles and every 200 miles thereafter:
 - a. Check dryer wheel hub and spindle temperature immediately after stopping. Temperature should not exceed 150° F. It may be hot to touch, but not melting lubricant.
 - b. Check wheel lug nuts. They are factory torqued at 115 to 120 ft. lbs. Retighten, if required.

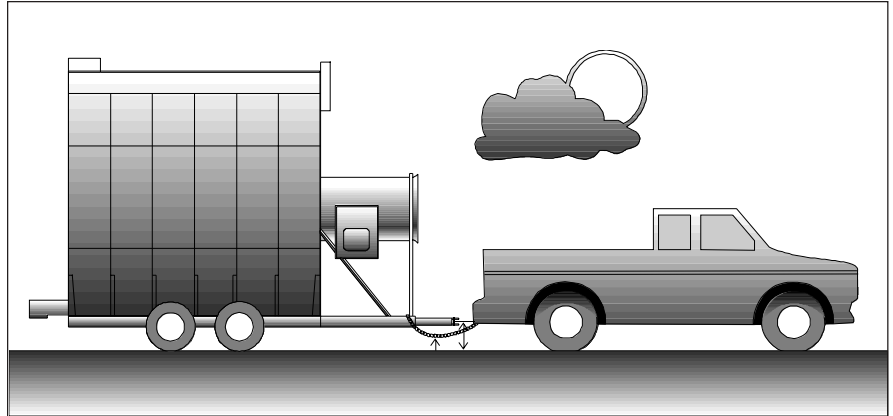

Figure 1: Use a 14-17 inch towing hitch height and a safety chain.

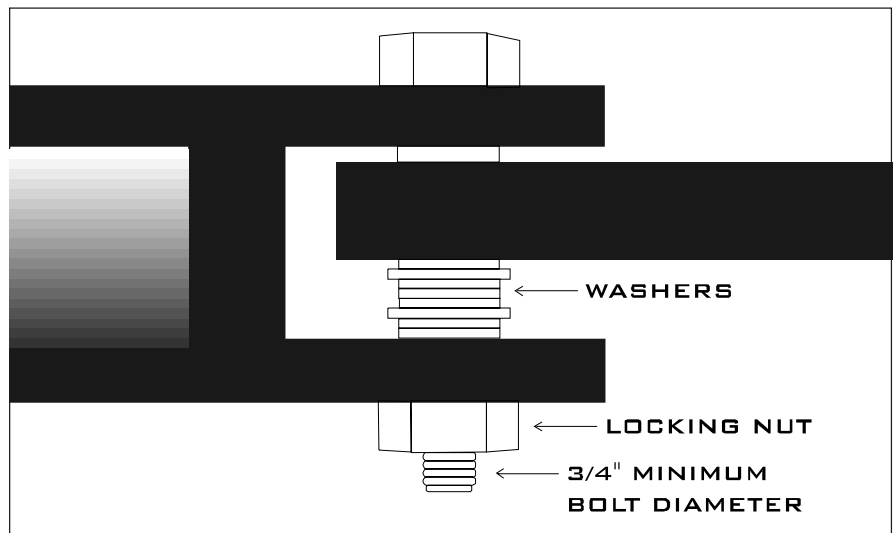

Figure 2: A 3/4 inch hitch bolt and washers fastened with a locking nut at the bottom of the hitch.

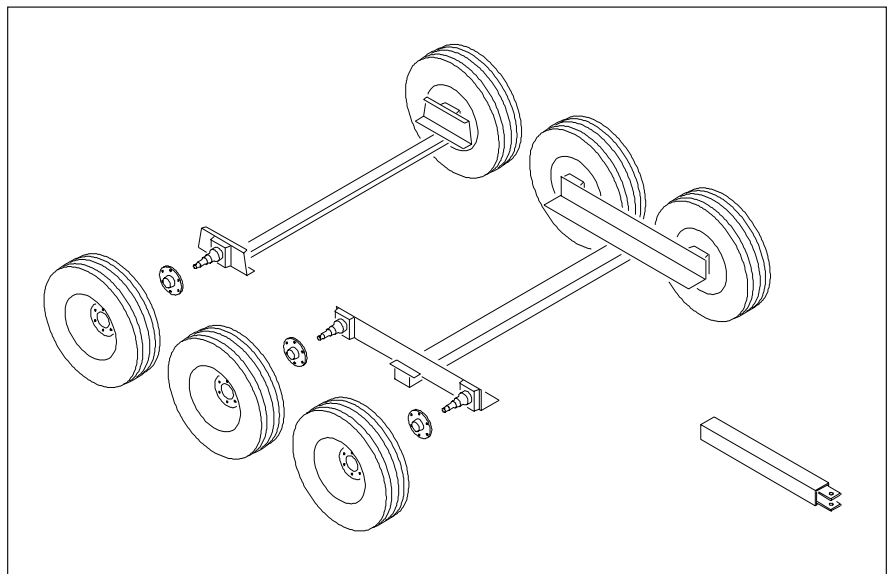
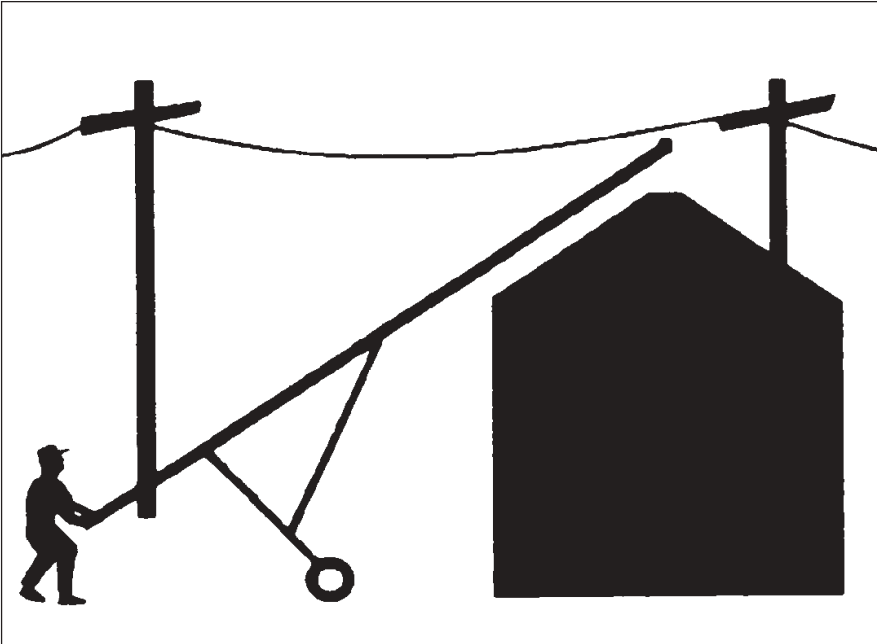

Figure 3: The grain dryer transport kit.

INSTALLATION



Do not maneuver augers in a raised position.

LOCATION OF THE DRYER

When considering the exact location of the dryer, keep in mind the wet grain supply and dry grain discharge, also the location of storage bins and other grain handling equipment. Do not install the dryer inside a building or any other area where electrical codes, fuel installation regulations and/or insurance requirements do not allow. *Maintain a minimum distance of at least three feet from other structures, or air flow problems may occur.* See page 13. Do not operate in an area where combustible materials can be drawn into the fans, or where load and unload augers can come in contact with power lines.

FOUNDATION

A reinforced concrete pad or similar permanent foundation is recommended for dryer stability. See pages 14 and 15 for details.

SUPPORTING THE DRYER

The wheels are for transporting the empty dryer only. Before loading any grain into the dryer, it is necessary to support the frame of the unit on each side. Support the frame with concrete blocks every six feet on each side plus at the hitch mount

USE A MINIMUM OF
ONE SUPPORT
PER EACH SIX FEET
OF BASKET LENGTH
ON EACH SIDE

location with the hitch removed. The blocks must support the dryer plus the weight of grain when full. Use shims to provide uniform, level support. The dryer should be at least 16 inches off the pad to allow for clean out and the use of auxiliary grain handling equipment. The hitch

tongue should be removed, but the hitch assembly and the fan support must be left on during operation; they are not part of the transport tie down assembly.

SUPPORTING THE DRYER WITH THE OPTIONAL STEEL SUPPORT LEGS

Anchor points may be cast into the concrete slab, or the dryer may be tied down by cable and turn-buckle to anchors installed at the edge of the slab. This is to prevent overturn or lateral movement by wind or other forces.

WET GRAIN SUPPLY

A wet grain holding bin provides gravity flow to the dryer or loading conveyor. This conveyor may be electrically connected to the power circuit provided in the main control box. At the beginning, the dryer will completely fill. During drying, the top auger will start and stop as required depending upon the dry grain discharge rate, and grain shrinkage to maintain the dryer fill. If the dryer does not fill within the time that you preset on the out of grain timer (see owners manual), the dryer will shut down.

DRY GRAIN REMOVAL

The dry grain is normally discharged out of the rear end of the dryer. Front discharge is an optional feature. A take away system needs to be provided to remove grain from the drying system. This conveyor may be electrically connected to the power circuit provided in the main control box.

INSTALLATION

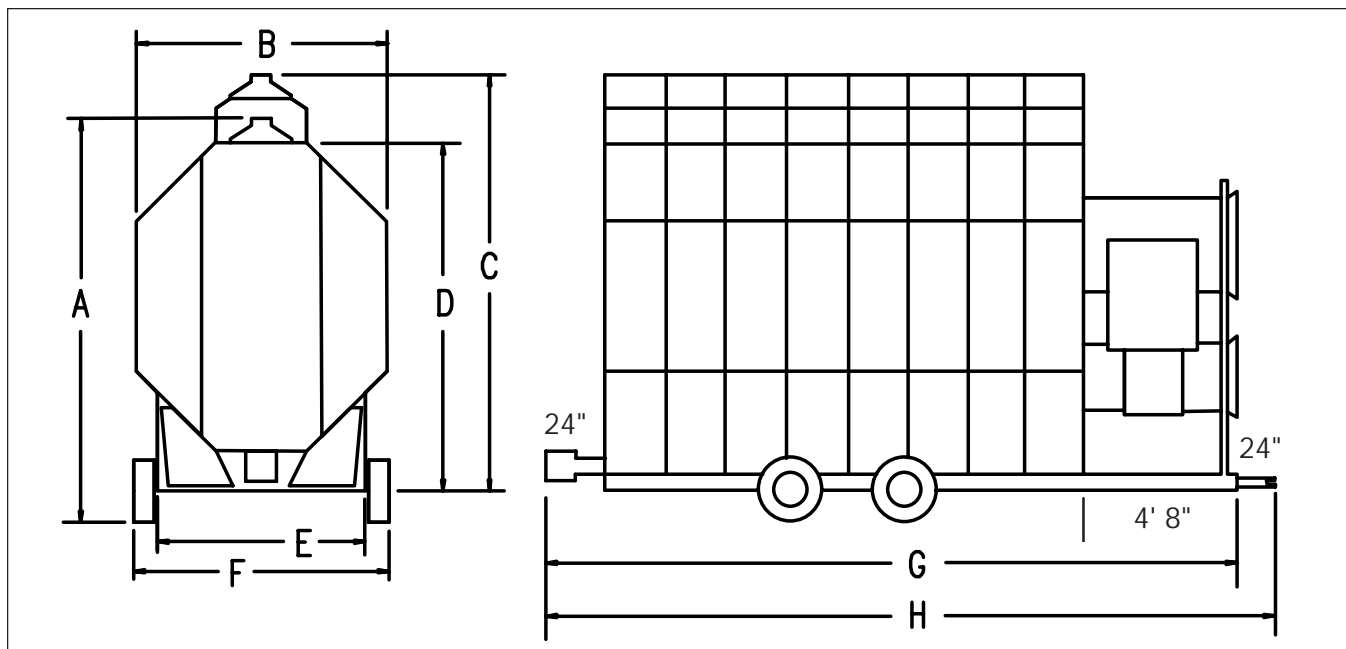

Diagram of dryer dimensions.

TRANSPORT AND INSTALLATION DIMENSIONS

DRYER MODEL NUMBER	A TRANSPORT HEIGHT	B INSTALLED WIDTH	C INSTALLED HEIGHT		D HEIGHT W/O WET BIN	E FRAME WIDTH	F TRANSPORT WIDTH	G INSTALLED LENGTH	H TRANSPORT LENGTH
1108	11' 6"	8'	13'	11' 8"	10' 1"	6' 5"	8'	14' 9"	16' 10"
1110	11' 6"	8'	13'	11' 8"	10' 1"	6' 5"	8'	16' 9"	18' 10"
1112	13' 5"	8'	14' 6"	13' 2"	11' 7"	6' 5"	8'	18' 9"	20' 10"
1114 1214	13' 5"	8'	14' 6"	13' 2"	11' 7"	6' 5"	8'	20' 9"	22' 10"
1116 1216	13' 5"	8'	14' 6"	13' 2"	11' 7"	6' 5"	8'	22' 9"	24' 10"
1118 1218	13' 5"	8'	14' 6"	13' 2"	11' 7"	6' 5"	8'	24' 9"	26' 10"
1120 1220	13' 5'	8'	14' 6"	13' 2"	11' 7"	6' 5"	8'	26' 9"	28' 10"
1122 1222	13' 5"	8'	14' 6"	13' 2"	11' 7"	6' 5"	8'	28' 9"	30' 10"
1126 1226	13' 5"	8'	14' 6"	13' 2"	11' 7"	6' 5"	8'	32' 9"	34' 10"
1314	13' 5"	8'	14' 6"	13' 2"	11' 7"	6' 5"	8'	20' 9"	22' 10"
1318	13' 5"	8'	14' 6"	13' 2"	11' 7"	6' 5"	8'	24' 9"	26' 10"
1322	13' 5"	8'	14' 6"	13' 2"	11' 7"	6' 5"	8'	28' 9"	30' 10"
1214S	13' 5"	11' 2"	14' 6"	13' 2"	11' 7"	6' 5"	8'	20' 9"	22' 9"
1218S	13' 5"	11' 2"	14' 6"	13' 2"	11' 7"	6' 5"	8'	24' 9"	26' 10"
1220S	13' 5"	11' 2"	14' 6"	13' 2"	11' 7"	6' 5"	8'	26' 9"	28' 10"
1222S	13' 5"	11' 2"	14' 6"	13' 2"	11' 7"	6' 5"	8'	28' 9"	30' 10"
1226S	13' 5"	11' 2"	14' 6"	13' 2"	11' 7"	6' 5"	8'	32' 9"	34' 10"
160AB	11' 11"	8'	N/A	11' 8"	10' 1"	6' 5"	8'	12' 9"	14' 10"
210AB	11' 11"	8'	N/A	11' 8"	10' 1"	6' 5"	8'	14' 9"	16' 10"
300AB	13' 5"	8'	N/A	13' 3"	11' 7"	6' 5"	8'	16' 9"	18' 10"
375AB	13' 5"	8'	N/A	13' 3"	11' 7"	6' 5"	8'	18' 9"	20' 10"
400AB	13' 5"	8'	N/A	13' 3"	11' 7"	6' 5"	8'	20' 9"	22' 10"
415AB	13' 5"	8'	N/A	13' 3"	11' 7"	6' 5"	8'	20' 9"	22' 10"
600AB	13' 5"	8'	N/A	13' 3"	11' 7"	6' 5"	8'	26' 9"	28' 10"

FOUNDATION LAY-OUT TYPICAL OF DRYER LINE

FOUNDATION CROSS SECTION

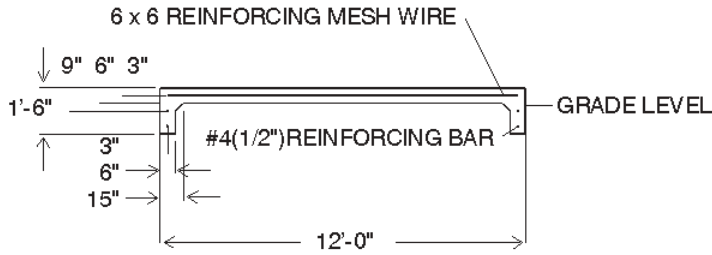

REAR VIEW

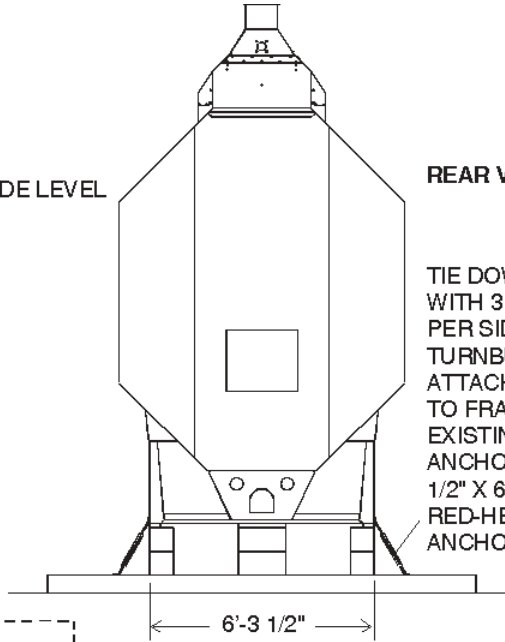

TIE DOWN DRYER WITH 3 TURNBUCKLES PER SIDE. BEND TURNBUCKLE EYES. ATTACH TURNBUCKLE TO FRAME USING EXISTING HOLES. ANCHOR TO PAD WITH 1/2" X 6" OR 5/8" X 6" RED-HEAD WEDGE ANCHOR BOLT.

FRONT FILL OPTION

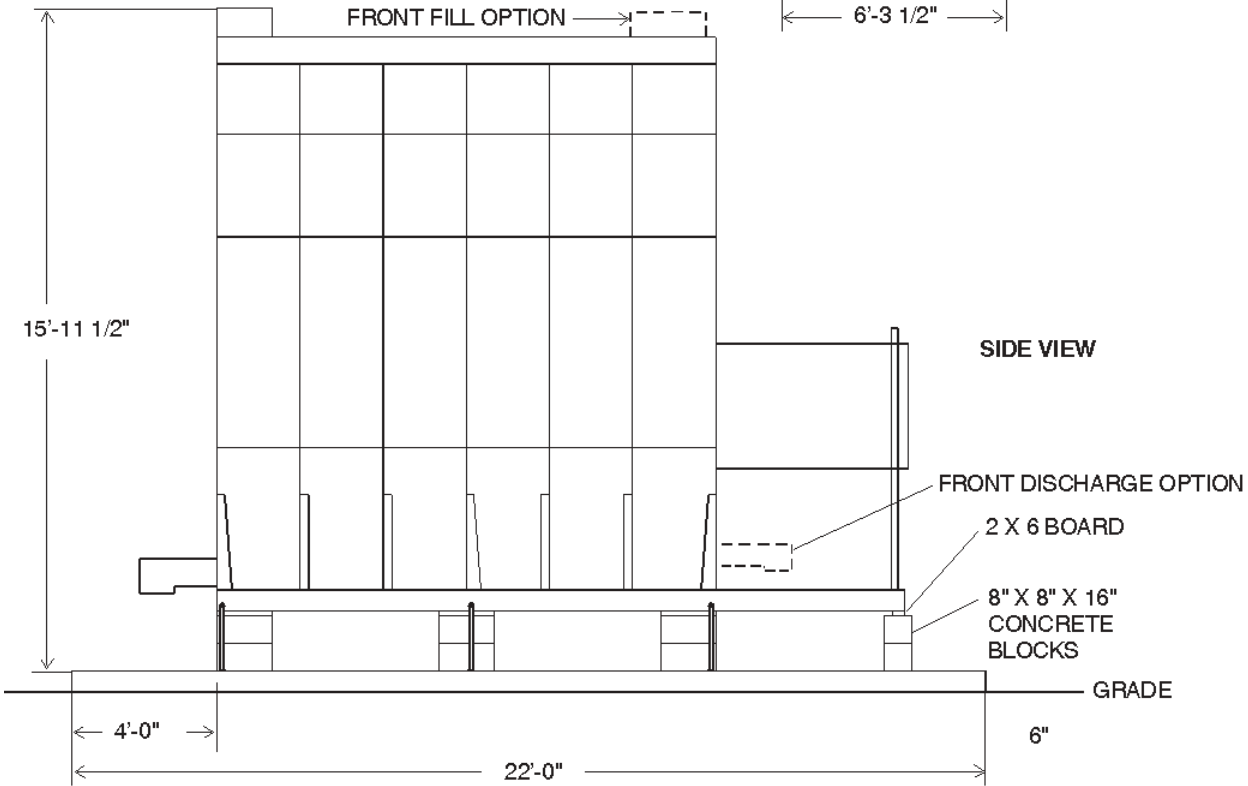

SIDE VIEW

TOP VIEW

THESE DIMENSIONS ARE VALID FOR ANY LENGTH DRYER

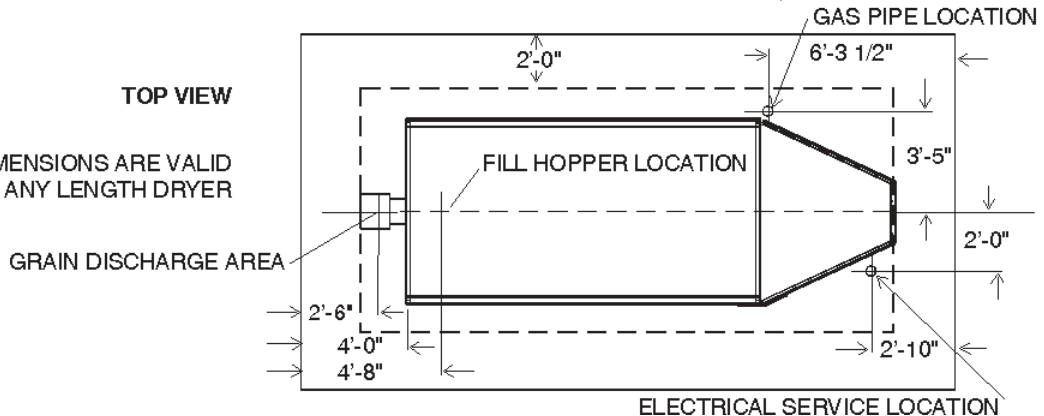

ELECTRICAL SERVICE LOCATION

FOUNDATION SPECIFICATIONS FOR DRYERS

MINIMUM BAG MIX FOR CONCRETE STRENGTH PER MODEL WEIGHT

Dryer Basket Length	6	8	10	12	14	16	18	20	22	26
Concrete Pad Size	12 x 16	12 x 18	12 x 20	12 x 22	12 x 24	12 x 26	12 x 28	12 x 30	12 x 32	12 x 36
Yards Concrete	5.3	5.9	6.5	7.1	7.7	8.3	8.9	9.2	10.1	11.3
Reinforcing Rods 20" each	6	6	7	7	7	8	8	8	9	10
Wire Mesh Sq. Ft.	192	216	240	264	288	312	336	360	384	432
Steel Legs(minimum)	8	8	10	10	12	12	14	14	16	18
Anchors	4	4	4	6	6	6	8	8	8	10
Blocks	10	14	14	18	18	18	22	22	26	30
Foot of 2 x 6	10	14	14	18	18	18	22	22	26	30
Turnbuckles	4	4	4	6	6	6	8	8	8	10
Estimated Manhours	8	10	12	14	18	18	20	22	24	28

Quantities are approximate and requirements may vary due to site elevations.
Setup times do not include preparing site and pouring concrete pad.



An installation using block support and cable tie-downs on a concrete slab foundation.

WET BIN ASSEMBLY INSTRUCTIONS

WET BIN ASSEMBLY INSTRUCTIONS

1. Check to see that all parts listed on packing list are inside dryer.
2. Remove the wet bin side shipping brackets. (Figure 4, no. 1).
3. Depending on the length of the dryer, the wet bin assembly will either have one or two wet bin lift mechanisms, or none on batch AB models or 1110 or smaller. On those dryers equipped with the lift mechanism, start raising the fill auger housing by uniformly taking up the lift turnbuckles. (Figure 4, no. 2) On short dryers not equipped with the lift mechanism, the fill auger housing can be manually lifted. *Note: During the initial stages of raising the fill auger housing, make sure that all four corners pick up uniformly or damage can occur to the top auger. Free by hand assist or prying, if required.*
4. Once the fill auger housing and wet bin are in an upright position, attach the end tie channel and the end top angle, (Figure 4, no. 3 and 4) using 5/16" x 3/4" bolts and nuts with serrated flange supplied in the wet bin hardware package. *Note: These bolts install from inside the wet bin therefore they must be in place prior to folding up the wet bin sides.*
5. Install bolts without tightening, to the wet bin left side end panel, (Figure 4, no. 5) adjacent to the fill auger motor. *Note: All the wet bin side panels bolt into place using 5/16" x 3/4" bolts and nuts with serrated flange for all round bolt holes and #14 x 3/4" self tapping screws for all slotted bolt holes.*
6. Fold up the side panels located on the other three corners of the wet bin. And install bolts without tightening, then fold up and loosely bolt the remaining wet bin side panels working from front to back.
7. Repeat steps 5 and 6 for the opposite side of the wet bin. *Note: Before folding up the front end panel install 3/8" x 4" hex head bolt into the belt guard body mounting hole (Figure 4, no. 9).*
8. Tighten all bolts and screws. *Note: Take care not to over tighten and strip threads on self tapping screws.*
9. Install hopper assembly on top of the fill auger housing, (Figure 4, no. 6) using #14 x 3/4" self tapping screws through the six holes located inside the hopper and three 5/16" x 3/4" bolts and nuts with serrated flange located outside the hopper.
10. Loosen the fill auger motor from its shipping position and attach the fill auger belt tensioner turnbuckle to the motor mount as shown (Figure 4, no. 7).
11. Loosen the mercury switch box assembly from its shipping position (attached to the upper junction box on the top left side of the dryer, except on front fill models where it is positioned in the rear of the dryer). Attach the switch box to the mercury switch paddle shaft, (Figure 4, no. 8) by tightening the allen screw in the switch box attachment collar. *Note: Make sure the top of the switch box is mounted in a level, horizontal position (top of the box is labeled top).*

MOUNTING TOP AUGER BELTS AND SAFETY SHIELD

After the top auger is lifted into place and the wet bin assembled, attach the belt guard mounting bracket (Figure 4, no. 11) to the top auger.

Using the 3/8" x 4" hex head bolts with the 3/8" hex nuts and lockwashers, bolt in place the belt guard body (Figure 4, no. 12) using the three holes shown (Figure 4, no. 9 and 10).

Install small pulley (Figure 4, no. 13) on top auger motor with keyway (Figure 4, no. 16) and large pulley (Figure 4, no. 14) on top auger with bushing (Figure 4, no. 17). Check for proper alignment of pulleys when installing the belts (Figure 4, no. 15). Adjust belt tensioner (Figure 4, no. 7) making sure there is sufficient clearance between belts and the belt guard body. Tighten locking nuts on the belt tensioner once belts are tightened. If adjustment is necessary, loosen the three mounting bolts and move the belt guard body to a better position.

Install the cover (Figure 4, no. 18) to the belt guard body using the attached clips.

WET BIN ASSEMBLY INSTRUCTIONS

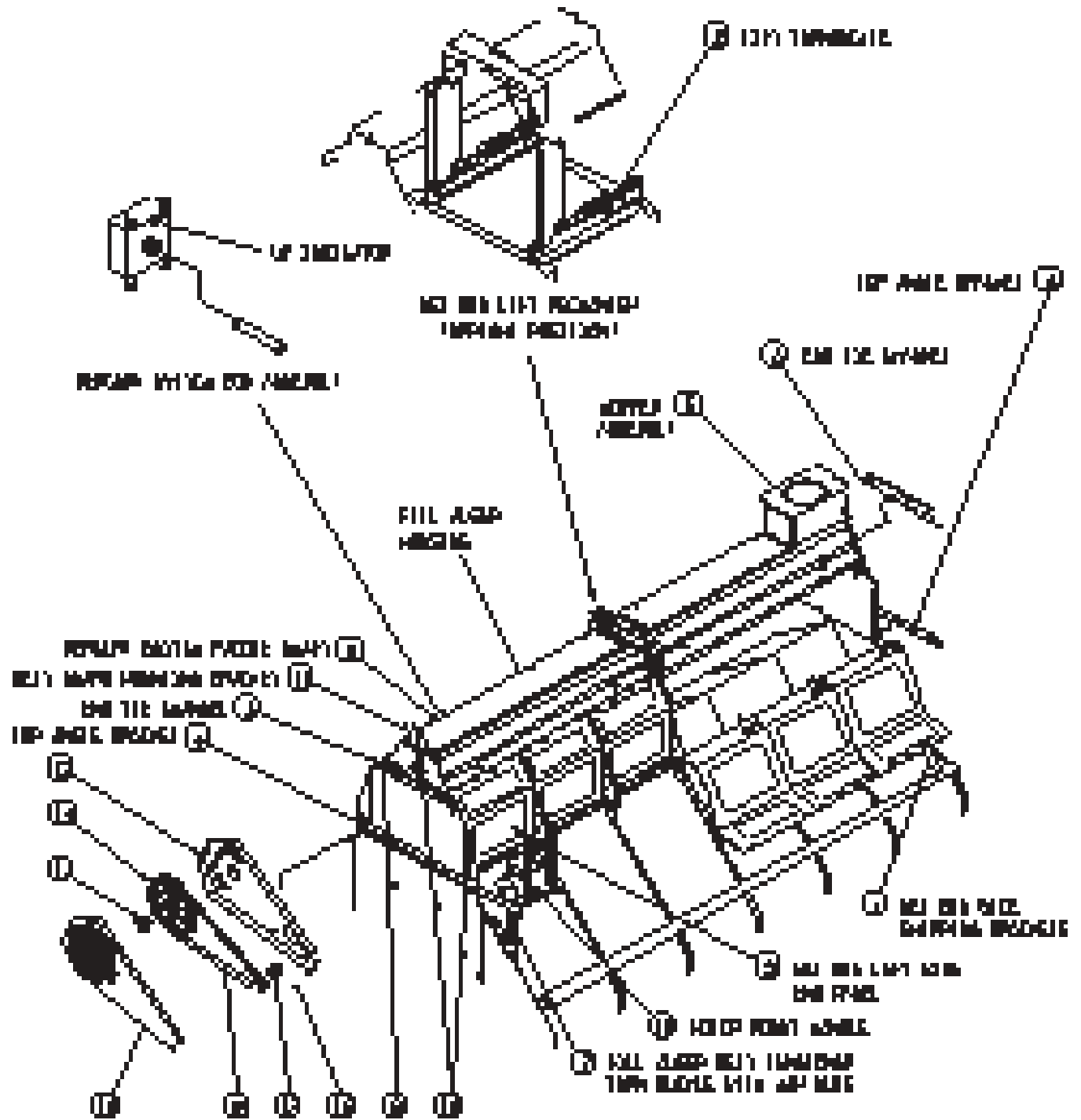

Figure 4: Parts breakdown of the wet bin and auger housing with belts and safety shield.

WET BIN ASSEMBLY INSTRUCTIONS

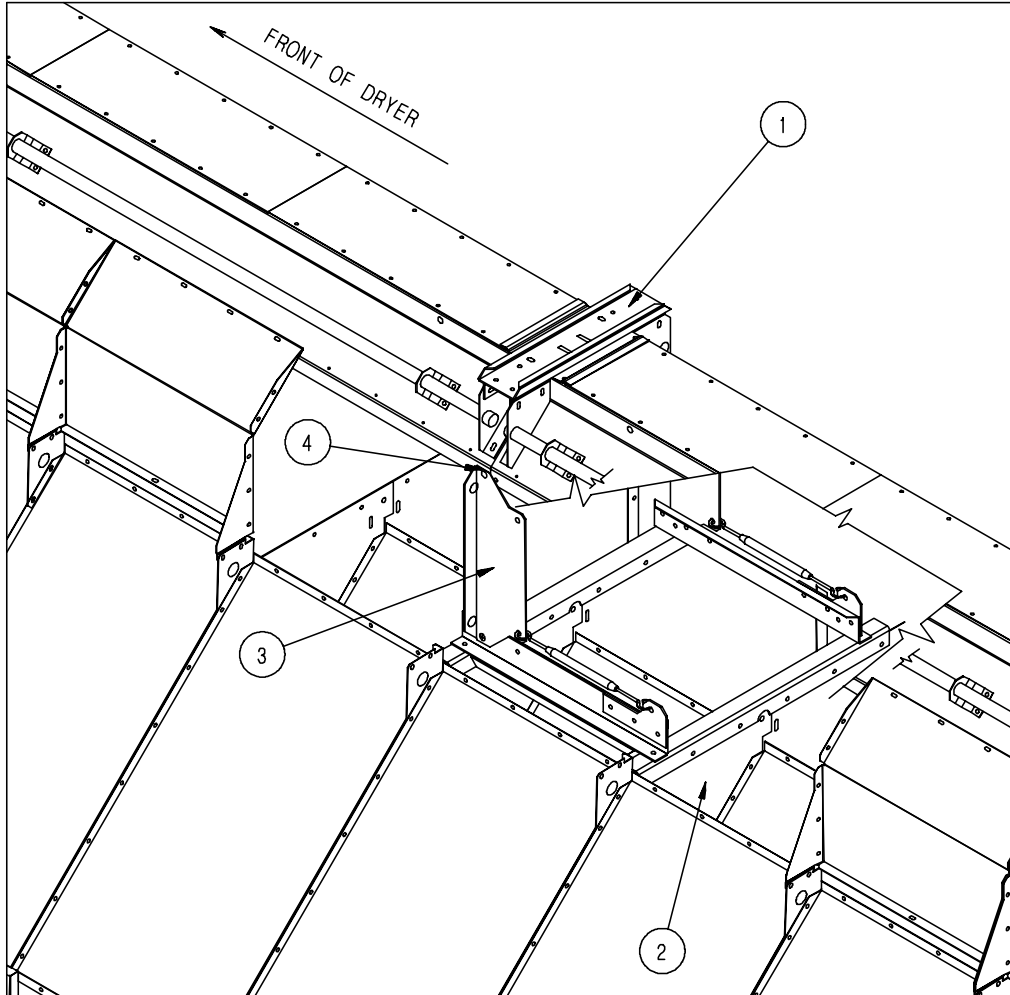

Figure 5: Cutaway view of the installed wet bin.

Note the location of splices on the top auger assembly and the distance from the end to each splice. Top auger sections have three lengths: 6'-(3 columns), 8'-(4 columns), and 10'-(5 columns).

The wet bin lift kit installs under the spliced section and hanger bearing of the top auger assembly (1). It is bolted to the garner bulkheads (2) on each side of the hanger bearing using standard whiz nuts and bolts (S-6606 and S-3611) supplied in the hardware package. The lift kit should be bolted so the vertical supports (3)

are to the front of the dryer in relation to the rest of the mechanism. This allows the top auger to be folded toward the front of the dryer as it was designed.

The vertical supports of the wet bin lift kit bolt to the hole (4) located on the bottom flange of the forward top auger section next to the section splice. A 3/8" bolt, nut and washer (S-3949, S-248 and S-6492) from the hardware package should be used for this.

The wet bin lift kit provides support for the top auger assembly when installed on the dryer, there-

fore, it should remain in place once installed. This is also useful if the dryer is ever moved and the wet bin disassembled in the future.

Once the top auger assembly is in place, the wet bin side panels can be raised. If it appears that the wet bin does not seem to fit, loosen all bolts holding the wet bin side panels together. These panels should then be bolted to the top auger assembly one at a time--starting from the ends and working toward the center, and the flanges should be bolted together after the panels are in the correct position.

FUEL CONNECTION

LIQUID PROPANE (LP)

LIQUID DRAW

Airstream dryers have internal vaporizers, and they are designed to operate on liquid draw from the supply tank. The tank should be 1,000 gallons or larger, and have no regulator mounted to it. The connection to the dryer should be with a flexible hose designed for LP gas, see chart for proper size. Consult your LP gas dealer for proper fittings, connection hose

and safety controls required to meet local standards and to conform with national fire protection association standards. The piping train on the dryer includes strainer, pressure relief valve, electronic safety shut off valve (on some models) and a pressure regulator between the vaporizer and burner.

AMMONIA TANKS

Do not use tanks which have previously been used for ammonia or fertilizer solutions. These substances

are extremely corrosive and will damage fuel supply and burner parts.

OIL OR WATER IN TANKS

With liquid draw from the supply tank any water or oil present in the tank may freeze in the pipe train or controls causing damage. To make sure the tank is free of moisture it can be purged with methanol. Avoid tanks which may contain an accumulation of oil or heavy hydrocarbon from long use on a vapor withdrawal system.

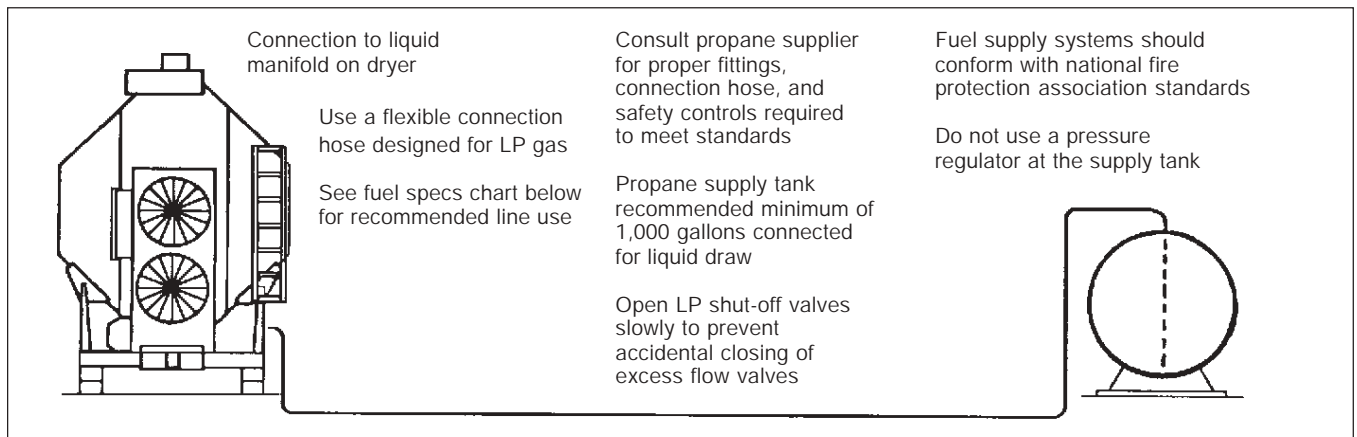

Figure 5: A grain dryer connected to a liquid propane tank.

FUEL SYSTEM SPECIFICATIONS & RECOMMENDATIONS (LP) LIQUID PROPANE

DRYER MODEL NUMBER	MAXIMUM HEAT CAPACITY BTU PER HOUR	MAXIMUM FUEL FLOW GALS PER HOUR	FUEL LINE SIZE*	HEATER ORIFICE DRILL SIZE
1108	3,000,000	33	1/2"	1/4"
1110	3,500,000	38	1/2"	9/32"
1112	4,500,000	49	1/2"	21/64"
1114	5,750,000	63	1/2"	11/32"
1116	5,750,000	63	1/2"	11/32"
1118	6,750,000	74	1/2"	3/8"
1120	7,500,000	82	1/2"	25/64"
1122	8,750,000	96	3/4"	7/16"
1126	10,250,000	112	3/4"	29/64"
1214	6,200,000	68	3/4"	(U)9/32" (L)7/32"
1216	7,200,000	79	3/4"	(U)21/64" (L)7/32"
1218	7,200,000	79	3/4"	(U)21/64" (L)7/32"
1220	8,500,000	93	3/4"	(U)11/32" (L)1/4"

FUEL CONNECTION

DRYER MODEL NUMBER	MAXIMUM HEAT CAPACITY BTU PER HOUR	MAXIMUM FUEL FLOW GALS PER HOUR	FUEL LINE SIZE*	HEATER ORIFICE DRILL SIZE
1222	9,750,000	107	3/4"	(1)3/8" (1)1/4"
1226	10,500,000	115	3/4"	(1)25/64" (1)1/4"
1314	8,100,000	88	3/4"	(3)7/32"
1318	8,100,000	88	3/4"	(3)7/32"
1322	8,100,000	88	3/4"	(3)7/32"
160AB	3,000,000	33	1/2"	1/4"
210AB	3,500,000	33	1/2"	1/4"
300AB	4,500,000	49	1/2"	21/64"
375AB	5,500,000	60	1/2"	21/64"
400AB	5,500,000	60	1/2"	21/64"
415AB	7,000,000	66	1/2"	(2)9/32"
600AB	9,000,000	98	3/4"	(2)21/64"

*Minimum line size for a 100' distance.

NATURAL GAS (N)

GAS VOLUME AND PRESSURE

The dryer is designed to operate on natural gas having a heat value of about 1,000 BTU per cubic foot. The dryer is equipped with a natural gas supply pipe system connected to the

heater solenoid valves. A regulated pressure of 10 PSI must be provided at the connection to the dryer, with gas available in sufficient volume to maintain the operating pressure.

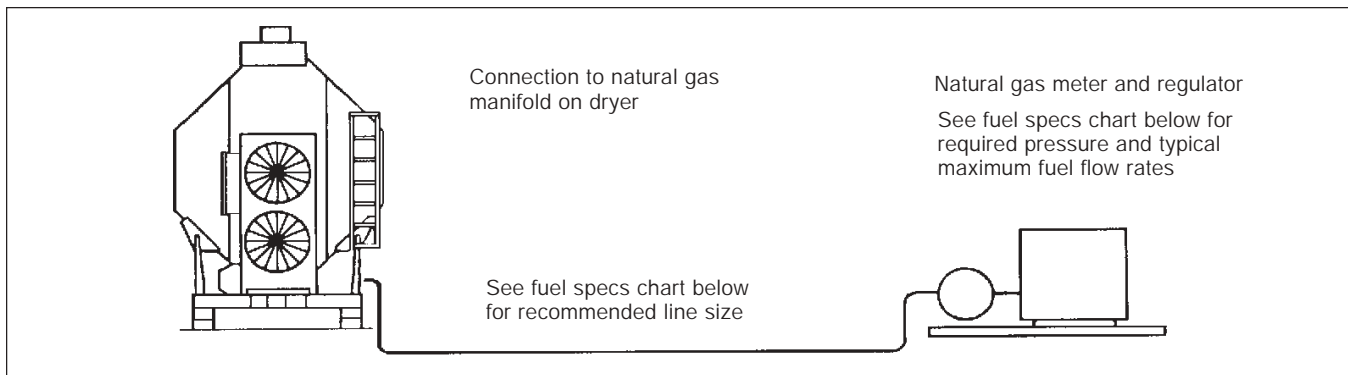

Figure 6: A grain dryer connected to a natural gas supply tank.

FUEL SYSTEM SPECIFICATIONS & RECOMMENDATIONS (N) NATURAL GAS

DRYER MODEL NUMBER	MAXIMUM HEAT CAPACITY BTU PER HOUR	MAXIMUM FUEL FLOW CUBIC FEET PER HOUR	FUEL LINE SIZE*	HEATER ORIFICE DRILL SIZE
1108	3,000,000	3,000	1 1/4" DIA	3/8"
1110	3,500,000	3,500	1 1/4" DIA	13/32"
1112	4,500,000	4,500	1 1/2" DIA	1/2"
1114	5,750,000	5,750	1 1/2" DIA	33/64"
1116	5,750,000	5,750	1 1/2" DIA	33/64"
1118	6,750,000	6,750	2" DIA	35/64"
1120	7,500,000	7,500	2" DIA	37/64"
1122	8,750,000	8,750	2" DIA	19/32"
1126	10,250,000	10,250	2" DIA	41/64"

FUEL CONNECTION

FUEL SYSTEM SPECIFICATIONS & RECOMMENDATIONS (N) NATURAL GAS

DRYER MODEL NUMBER	MAXIMUM HEAT CAPACITY BTU PER HOUR	MAXIMUM FUEL FLOW CUBIC FEET PER HOUR	FUEL LINE SIZE*	HEATER ORIFICE DRILL SIZE
1214	6,200,000	6,200	1 1/2" DIA	(1)13/32" (1)5/16"
1216	7,200,000	7,200	2" DIA	(1)1/2" (1)5/16"
1218	7,200,000	7,200	2" DIA	(1)1/2" (1)5/16"
1220	8,500,000	8,500	2" DIA	(1)33/64" (1)3/8"
1222	9,750,000	9,750	2" DIA	(1)35/64" (1)3/8"
1226	10,500,000	10,500	2" DIA	(1)37/64" (1)3/8"
1214S	6,000,000	6,000	1 1/2" DIA	(2)3/8"
1218S	6,000,000	6,000	1 1/2" DIA	(2)13/32"
1220S	9,000,000	9,000	2"DIA	(2)1/2"
1222S	9,000,000	9,000	2"DIA	(2)1/2"
1226S	13,500,000	13,500	2" DIA	(2)17/32"
1314	8,100,000	8,100	2" DIA	(3)5/16"
1318	8,100,000	8,100	2" DIA	(3)5/16"
1322	8,100,000	8,100	2" DIA	(3)5/16"
160AB	3,000,000	3,000	1 1/4" DIA	3/8"
210AB	3,500,000	3,500	1 1/4" DIA	13/32"
300AB	4,500,000	4,500	1 1/2" DIA	1/2"
375AB	5,500,000	5,500	1 1/2" DIA	33/64"
400AB	5,500,000	5,500	1 1/2" DIA	33/64"
415AB	7,000,000	7,000	2" DIA	(2)13/32"
600AB	9,000,000	9,000	2" DIA	(2)1/2"

*Minimum line size for a 100' distance.



The fuel connection point is equipped with a Y-strainer and Maxon safety valve.

ELECTRICAL POWER SUPPLY

POWER SUPPLY

An adequate power supply and proper wiring are important factors for maximum performance and long life of the dryer. Electrical service must be adequate enough to prevent low voltage damage to motors and control circuits. (See Electrical Load Information, page 21-28) Power supply for single phase models must include a neutral wire.

TRANSFORMERS AND WIRING VOLTAGE DROP

Advise the service representative of your local power supplier that an additional load will be placed on the line. Check on KVA rating of trans-

formers, considering total horsepower load. The power supply wiring, main switch equipment and transformers must provide adequate motor starting and operating voltage. Voltage drop during motor starting should not exceed 14% of normal voltage, and after motor is running at full speed it should be within 8% of normal voltage. Check Electrical Load Information (pages 23-30) for HP ratings and maximum amp loads.

POWER SUPPLY DISCONNECT

All dryers are equipped with a power disconnect switch in the power box to permit total power shutdown be-

fore opening the power box door, as required for inspection and service. The power disconnect switch is located on the power box door for quick shutdown.

MACHINE TO EARTH GROUNDING

It is very important that a *Machine To Earth Ground Rod* be installed at the dryer. Place the ground rod that comes standard, within 8 feet of the dryer and attach it to the dryer control panel with at least a #6 solid, bare, copper ground wire and the clamp provided. The grounding rod located at the power pole will not provide adequate grounding for the

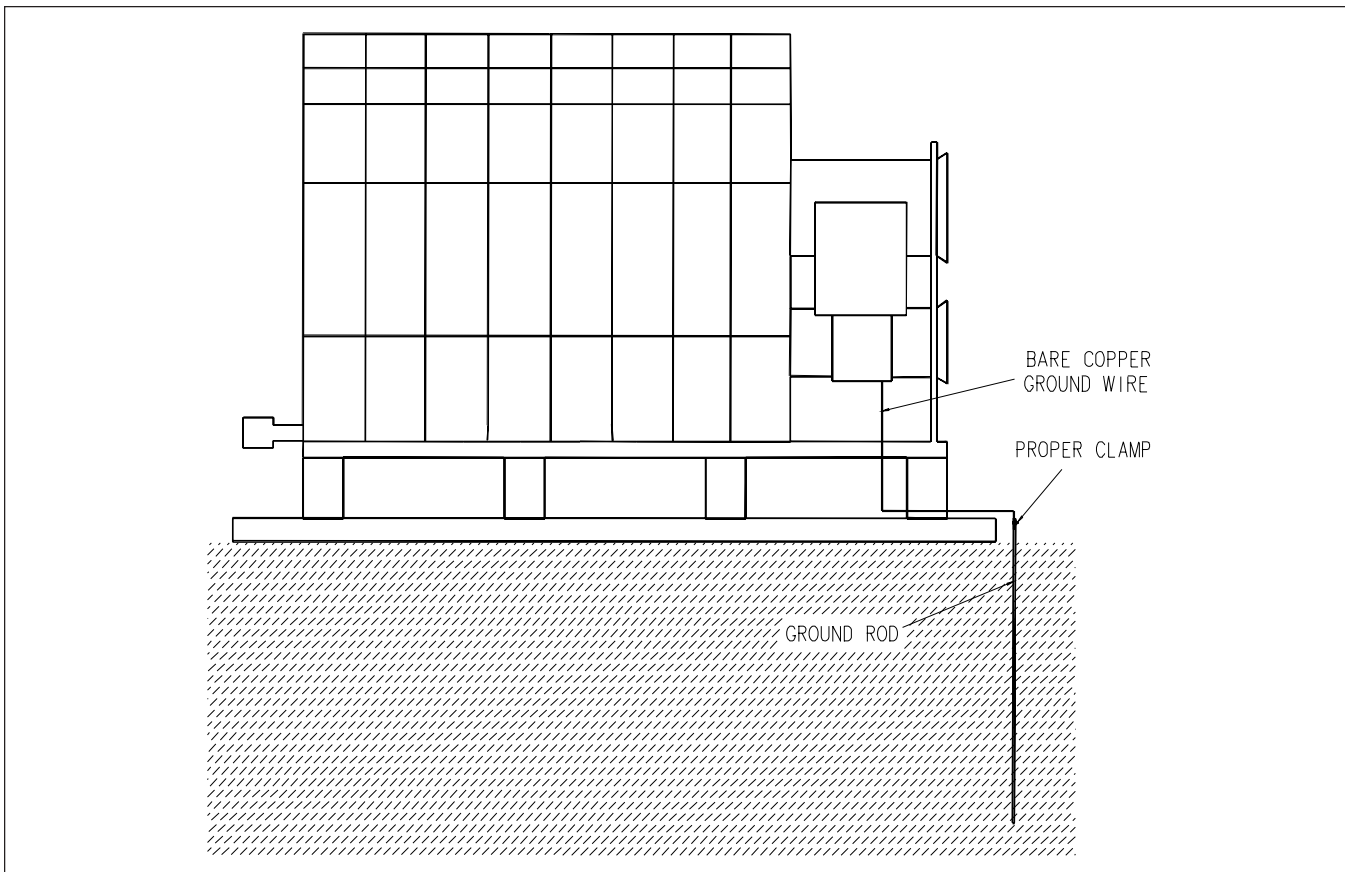

Figure 7: Installation of a ground rod (standard with dryer purchase) specifically for the grain dryer is necessary for safety and equipment preservation.

ELECTRICAL POWER SUPPLY

dryer. The proper grounding will provide additional safety in case of any short and will ensure long life of all circuit boards, SCR drive, and the ignition system. The ground rod must be in accordance with local requirements.

PROPER INSTALLATION OF GROUND ROD

It is not recommended that the rod be driven into dry ground. Follow these instructions for proper installation.

1. Dig a hole large enough to hold 1 to 2 gallons of water.
2. Fill hole with water.
3. Insert rod through water and jab it into the ground.
4. Continue jabling the rod up and down. The water will work its way down the hole, making it possible to work the rod completely into the ground. This method of installation assures good contact with the surrounding soil, making a proper ground.
5. Connect the bare, copper ground wire to the rod with the proper clamp.
6. Connect ground wire to control panel with the ground lug provided in the control box.
7. Ground wire must not have any breaks or splices. Insulated wire is not recommended for grounding applications.

CONNECTING AUXILIARY CONVEYORS

The auxiliary load and auxiliary unload augers or conveyors can be wired directly to the dryer. Electrical Load Information (page 23-30) shows the maximum horse power and amps of auxiliaries that can be wired to the

dryer. If an auxiliary motor is larger than what is recommended, then it must be powered from a source outside the dryer, and must use a separate contactor and overload protection device for each motor. However, the operation of the auxiliaries can be performed by the control panel.



Dig a hole large enough to hold 1 or 2 gallons of water. Work the ground rod into the earth until it is completely in the ground.

ELECTRICAL LOAD INFORMATION

The following charts provide information for the electrician wiring the grain dryer, and are a reference guide for parts. It is recommended that you contact your local power company and have a representative survey the installation to see

that your wiring is compatible with their system and that adequate power is supplied to your unit. Remember that the only thing connected to the recommended service amps should be your grain dryer.

Standard electrical safety practices and codes should be used. (Refer to National Electrical Code Standard Handbook by National Fire Protection Association.) A qualified electrician should make all electrical wiring installations.

DRYER MODEL NUMBER	VOLTAGE	MOTOR	H.P.	FULL LOAD AMPS	MAX. AMPS WITH AUXILIARIES	MINIMUM AMPS	RECOMMENDED SERVICE IN AMPS	RELAY HEATER STRIPS	BRANCH BREAKER IN AMPS
1108	1 PH 230V	TOP AUGER	1.5	8	153	62.5	200	C104B	60
		BOT. AUGER	1	6.5				C867A	60
		FAN	10 TO 12	48				F614B	100
		(2) AUXILIARY	(2) 7.5	62				C330B	*
	3 PH 220V	TOP AUGER	1.5	5	104	41.4	150	C630A	50
		BOT. AUGER	1	3.4				C419A	50
		FAN	10 TO 12	33				C366B	60
		(2) AUXILIARY	(2) 7.5	40				C228B	*
	3 PH 440V	TOP AUGER	1.5	2.5	57	20.7	150	C356A	60
		BOT. AUGER	1	1.7				C239A	60
		FAN	10 TO 12	16.5				C180B	60
		(2) AUXILIARY	(2) 7.5	20				C137B	*
1110	1 PH 230V	TOP AUGER	2	14	162	70	225	C163B	60
		BOT. AUGER	1.5	8				C104B	60
		FAN	10 TO 12	48				F614B	100
		(2) AUXILIARY	(2) 7.5	62				C330B	*
	3 PH 220V	TOP AUGER	2	6.2	101	39.2	150	C778A	50
		BOT. AUGER	1.5	5				C630A	50
		FAN	10	28				C330B	60
		(2) AUXILIARY	(2) 7.5	40				C228B	*
	3 PH 440V	TOP AUGER	2	3.1	56	19.6	150	C379A	60
		BOT. AUGER	1.5	2.5				C356A	60
		FAN	10	14				C180B	60
		(2) AUXILIARY	(2) 7.5	20				C137B	*
1112	1 PH 230V	TOP AUGER	2	14	196	100	300	C163B	60
		BOT. AUGER	1.5	8				C104B	60
		FAN	10 TO 17	78				F914B	100
		(2) AUXILIARY	(2) 7.5	62				C330B	*
	3 PH 220V	TOP AUGER	2	6.2	114	50.2	175	C778A	50
		BOT. AUGER	1.5	5				C630A	50
		FAN	15	39				C400B	60
		(2) AUXILIARY	(2) 7.5	40				C228B	*
	3 PH 440V	TOP AUGER	2	3.1	62	25.1	150	C379A	60
		BOT. AUGER	1.5	2.5				C356A	60
		FAN	15	19.5				C228B	60
		(2) AUXILIARY	(2) 7.5	20				C137B	*

*AUXILIARIES RUN THROUGH LOAD AND UNLOAD BREAKERS
SUBJECT TO CHANGE WITHOUT NOTIFICATION

ELECTRICAL LOAD INFORMATION

DRYER MODEL NUMBER	VOLTAGE	MOTOR	H.P.	FULL LOAD AMPS	MAX. AMPS WITH AUXILIARIES	MINIMUM AMPS	RECOMMENDED SERVICE IN AMPS	RELAY HEATER STRIPS	BRANCH BREAKER IN AMPS
1114	1 PH 230V	TOP AUGER	5	26	231	130	350	C303B	100
		BOT. AUGER	5	26				C303B	100
		FAN	10 TO 17	78				F914B	100
		(2) AUXILIARY	(2) 7.5	62				C330B	*
	3 PH 220V	TOP AUGER	5	13.2	145	65.4	200	C163B	60
		BOT. AUGER	5	13.2				C163B	60
		FAN	15	39				C400B	60
		(2) AUXILIARY	(2) 10	52				C303B	*
	3 PH 440V	TOP AUGER	5	6.6	78	32.7	150	C867A	60
		BOT. AUGER	5	6.6				C867A	60
		FAN	15	19.5				C228B	60
		(2) AUXILIARY	(2) 10	26				C163B	*
1116	1 PH 230V	TOP AUGER	5	26	231	130	350	C303B	100
		BOT. AUGER	5	26				C303B	100
		FAN	10 TO 17	78				F914B	100
		(2) AUXILIARY	(2) 7.5	62				C330B	*
	3 PH 220V	TOP AUGER	5	13.2	145	65.4	200	C163B	60
		BOT. AUGER	5	13.2				C163B	60
		FAN	15	39				C400B	60
		(2) AUXILIARY	(2) 10	52				C303B	*
	3 PH 440V	TOP AUGER	5	6.6	78	32.7	150	C867A	60
		BOT. AUGER	5	6.6				C867A	60
		FAN	15	19.5				C228B	60
		(2) AUXILIARY	(2) 10	26				C163B	*
1118	3 PH 220V	TOP AUGER	5	13.2	158	76.4	250	C163B	60
		BOT. AUGER	5	13.2				C163B	60
		FAN	20	50				F614B	90
		(2) AUXILIARY	(2) 10	52				C303B	*
	3 PH 440V	TOP AUGER	5	6.6	84	38.2	150	C867A	60
		BOT. AUGER	5	6.6				C867A	60
		FAN	20	25				C303B	60
		(2) AUXILIARY	(2) 10	26				C163B	*
1120	3 PH 220V	TOP AUGER	7.5	20	219	104	300	C228B	90
		BOT. AUGER	7.5	20				C228B	90
		FAN	25	64				F772B	90
		(2) AUXILIARY	(2) 15	78				C400B	*
	3 PH 440V	TOP AUGER	7.5	10	115	52	200	C137B	60
		BOT. AUGER	7.5	10				C137B	60
		FAN	25	32				C330B	60
		(2) AUXILIARY	(2) 15	39				C228B	*
1122	3 PH 220V	TOP AUGER	7.5	20	231	114	300	C228B	90
		BOT. AUGER	7.5	20				C228B	90
		FAN	30	74				F914B	90
		(2) AUXILIARY	(2) 15	78				C400B	*
	3 PH 440V	TOP AUGER	7.5	10	120	57	200	C137B	60
		BOT. AUGER	7.5	10				C137B	60
		FAN	30	37				C400B	60
		(2) AUXILIARY	(2) 15	39				C228B	*

*AUXILIARIES RUN THROUGH LOAD AND UNLOAD BREAKERS

ELECTRICAL LOAD INFORMATION

DRYER MODEL NUMBER	VOLTAGE	MOTOR	H.P.	FULL LOAD AMPS	MAX. AMPS WITH AUXILIARIES	MINIMUM AMPS	RECOMMENDED SERVICE IN AMPS	RELAY HEATER STRIPS	BRANCH BREAKER IN AMPS
1126	3 PH 220V	TOP AUGER	10	26	277	154	400	C303B	90
		BOT. AUGER	10	26				C303B	90
		FAN	40	102				F118C	125
	(2) AUXILIARY	(2) 15	78	C400B	*				
	3 PH 440V	TOP AUGER	10	13	143	77	250	C163B	60
		BOT. AUGER	10	13				C163B	60
FAN		40	51	F614B				90	
(2) AUXILIARY	(2) 15	39	C228B	*					
1214	1 PH 230V	TOP AUGER	5	26	252	148	300	C303B	100
		BOT. AUGER	5	26				C303B	100
		TOP FAN	10 TO 12	48				F614B	100
		BOT. FAN	10 TO 12	48				F614B	100
		(2) AUXILIARY	(2) 7.5	62				C330B	*
	3 PH 220V	TOP AUGER	5	13.2	170	87.4	225	C163B	60
		BOT. AUGER	5	13.2				C163B	60
		TOP FAN	10	28				C330B	60
		BOT. FAN	10 TO 12	33				C366B	60
		(2) AUXILIARY	(2) 10	52				C303B	*
	3 PH 440V	TOP AUGER	5	6.6	90	43.7	150	C867A	60
		BOT. AUGER	5	6.6				C867A	60
TOP FAN		10	14	C180B				60	
BOT. FAN		10 TO 12	16.5	C180B				60	
(2) AUXILIARY		(2) 10	26	C163B				*	
1216	1 PH 230V	TOP AUGER	5	26	286	178	400	C303B	100
		BOT. AUGER	5	26				C303B	100
		TOP FAN	10 TO 17	78				F914B	100
		BOT. FAN	10 TO 12	48				F614B	100
		(2) AUXILIARY	(2) 7.5	62				C330B	*
	3 PH 220V	TOP AUGER	5	13.2	183	98.4	225	C163B	60
		BOT. AUGER	5	13.2				C163B	60
		TOP FAN	15	39				C400B	60
		BOT. FAN	10 TO 12	33				C366B	60
		(2) AUXILIARY	(2) 10	52				C303B	*
	3 PH 440V	TOP AUGER	5	6.6	96	49.2	150	C867A	60
		BOT. AUGER	5	6.6				C867A	60
TOP FAN		15	19.5	C228B				60	
BOT. FAN		10 TO 12	16.5	C180B				60	
(2) AUXILIARY		(2) 10	26	C163B				*	
1218	1 PH 230V	TOP AUGER	5	26	286	178	400	C303B	100
		BOT. AUGER	5	26				C303B	100
		TOP FAN	10 TO 17	78				F914B	100
		BOT. FAN	10 TO 12	48				F614B	100
		(2) AUXILIARY	(2) 7.5	62				C330B	*
	3 PH 220V	TOP AUGER	5	13.2	183	98.4	225	C163B	60
		BOT. AUGER	5	13.2				C163B	60
		TOP FAN	15	39				C400B	60
		BOT. FAN	10 TO 12	33				C366B	60
		(2) AUXILIARY	(2) 10	52				C303B	*
	3 PH 440V	TOP AUGER	5	6.6	96	49.2	150	C867A	60
		BOT. AUGER	5	6.6				C867A	60
TOP FAN		15	19.5	C228B				60	
BOT. FAN		10 TO 12	16.5	C180B				60	
(2) AUXILIARY		(2) 10	26	C163B				*	

*AUXILIARIES RUN THROUGH LOAD AND UNLOAD BREAKERS

ELECTRICAL LOAD INFORMATION

DRYER MODEL NUMBER	VOLTAGE	MOTOR	H.P.	FULL LOAD AMPS	MAX. AMPS WITH AUXILIARIES	MINIMUM AMPS	RECOMMENDED SERVICE IN AMPS	RELAY HEATER STRIPS	BRANCH BREAKER IN AMPS	
1220	1 PH 230V	TOP AUGER	7.5	31	298	188	400	C330B	100	
		BOT. AUGER	7.5	31				C330B	100	
		TOP FAN	10 TO 17	78				F914B	100	
		BOT. FAN	10 TO 12	48				F614B	100	
	(2) AUXILIARY	(2) 7.5	62	C330B	*					
	3 PH 220V	TOP AUGER	7.5	20	229	112	300	C228B	90	
		BOT. AUGER	7.5	20				C228B	90	
		TOP FAN	15	39				C400B	60	
		BOT. FAN	10 TO 12	33				C366B	60	
	(2) AUXILIARY	(2) 15	78	C400B	*					
	3 PH 440V	TOP AUGER	7.5	10	123	59	200	C137B	60	
		BOT. AUGER	7.5	10				C137B	60	
TOP FAN		15	19.5	C228B				60		
BOT. FAN		10 TO 12	16.5	C180B				60		
(2) AUXILIARY	(2) 15	39	C228B	*						
1222	3 PH 220V	TOP AUGER	7.5	20	241	123	350	C228B	90	
		BOT. AUGER	7.5	20				C228B	90	
		TOP FAN	20	50				F614B	90	
		BOT. FAN	10 TO 12	33				C366B	60	
	(2) AUXILIARY	(2) 15	78	C400B	*					
	3 PH 440V	TOP AUGER	7.5	10	129	64.5	200	C137B	60	
		BOT. AUGER	7.5	10				C137B	60	
		TOP FAN	20	25				C303B	60	
		BOT. FAN	10 TO 12	16.5				C180B	60	
	(2) AUXILIARY	(2) 15	39	C228B	*					
	1226	3 PH 220V	TOP AUGER	10	26	271	149	350	C303B	90
			BOT. AUGER	10	26				C303B	90
TOP FAN			25	64	F772B				90	
BOT. FAN			10 TO 12	33	C366B				60	
(2) AUXILIARY		(2) 15	78	C400B	*					
3 PH 440V		TOP AUGER	10	13	144	77.5	200	C163B	60	
		BOT. AUGER	10	13				C163B	60	
		TOP FAN	25	32				C330B	60	
		BOT. FAN	10 TO 12	16.5				C180B	60	
(2) AUXILIARY		(2) 15	39	C228B	*					
1214S		1 PH 230V	TOP AUGER	5	26	252	148	350	C303B	100
			BOT. AUGER	5	26				C303B	100
	(2) FANS		(2) 10 TO 12	96	F614B				100	
	(2) AUXILIARY		(2) 7.5	62	C330B				*	
	3 PH 220V	TOP AUGER	5	13.2	176	92.4	225	C163B	60	
		BOT. AUGER	5	13.2				C163B	60	
		(2) FANS	(2) 10 TO 12	66				C366B	60	
		(2) AUXILIARY	(2) 10	52				C303B	*	
	3 PH 440V	TOP AUGER	5	6.6	93	46.2	150	C867A	60	
		BOT. AUGER	5	6.6				C867A	60	
		(2) FANS	(2) 10 TO 12	33				C180B	60	
		(2) AUXILIARY	(2) 10	26				C163B	*	

*AUXILIARIES RUN THROUGH LOAD AND UNLOAD BREAKERS

ELECTRICAL LOAD INFORMATION

DRYER MODEL NUMBER	VOLTAGE	MOTOR	H.P.	FULL LOAD AMPS	MAX. AMPS WITH AUXILIARIES	MINIMUM AMPS	RECOMMENDED SERVICE IN AMPS	RELAY HEATER STRIPS	BRANCH BREAKER IN AMPS
1218S	1 PH 230V	TOP AUGER	5	26	252	148	350	C303B	100
		BOT. AUGER	5	26				C303B	100
		(2) FANS	(2) 10 TO 12	96				F614B	100
		(2) AUXILIARY	(2) 7.5	62				C330B	*
	3 PH 220V	TOP AUGER	5	13.2	165	82.4	225	C163B	60
		BOT. AUGER	5	13.2				C163B	60
		(2) FANS	(2) 10	56				C330B	60
		(2) AUXILIARY	(2) 10	52				C303B	*
	3 PH 440V	TOP AUGER	5	6.6	87	41.2	150	C867A	60
		BOT. AUGER	5	6.6				C867A	60
		(2) FANS	(2) 10	28				C180B	60
		(2) AUXILIARY	(2) 10	26				C163B	*
1220S	1 PH 230V	TOP AUGER	7.5	31	332	218	400	C330B	100
		BOT. AUGER	7.5	31				C330B	100
		(2) FANS	(2) 10 TO 17	156				F914B	100
		(2) AUXILIARY	(2) 7.5	62				C330B	*
	3 PH 220V	TOP AUGER	7.5	20	235	118	300	C228B	90
		BOT. AUGER	7.5	20				C228B	90
		(2) FANS	(2) 15	78				C400B	60
		(2) AUXILIARY	(2) 15	78				C400B	*
	3 PH 440V	TOP AUGER	7.5	10	123	59	200	C137B	60
		BOT. AUGER	7.5	10				C137B	60
		(2) FANS	(2) 15	39				C228B	60
		(2) AUXILIARY	(2) 15	39				C228B	*
1222S	1 PH 230V	TOP AUGER	7.5	31	332	218	400	C330B	100
		BOT. AUGER	7.5	31				C330B	100
		(2) FANS	(2) 10 TO 17	156				F914B	100
		(2) AUXILIARY	(2) 7.5	62				C330B	*
	3 PH 220V	TOP AUGER	7.5	20	235	118	300	C228B	90
		BOT. AUGER	7.5	20				C228B	90
		(2) FANS	(2) 15	78				C400B	60
		(2) AUXILIARY	(2) 15	78				C400B	*
	3 PH 440V	TOP AUGER	7.5	10	123	59	200	C137B	60
		BOT. AUGER	7.5	10				C137B	60
		(2) FANS	(2) 15	39				C228B	60
		(2) AUXILIARY	(2) 15	39				C228B	*
1226S	3 PH 220V	TOP AUGER	10	26	307	180	400	C303B	90
		BOT. AUGER	10	26				C303B	90
		(2) FANS	(2) 25	128				F772B	90
		(2) AUXILIARY	(2) 15	78				C400B	*
	3 PH 440V	TOP AUGER	10	13	158	90	200	C163B	60
		BOT. AUGER	10	13				C163B	60
		(2) FANS	(2) 25	64				C330B	60
		(2) AUXILIARY	(2) 15	39				C228B	*

*AUXILIARIES RUN THROUGH LOAD AND UNLOAD BREAKERS

ELECTRICAL LOAD INFORMATION

DRYER MODEL NUMBER	VOLTAGE	MOTOR	H.P.	FULL LOAD AMPS	MAX. AMPS WITH AUXILIARIES	MINIMUM AMPS	RECOMMENDED SERVICE IN AMPS	RELAY HEATER STRIPS	BRANCH BREAKER IN AMPS
	1 PH 230V	TOP AUGER	5	26	307	196	400	C303B	100
		BOT. AUGER	5	26				C303B	100
		TOP FAN	10 TO 12	48				F614B	100
		MID. FAN	10 TO 12	48				F614B	100
		BOT. FAN	10 TO 12	48				F614B	100
		(2) AUXILIARY	(2) 7.5	62				C330B	*
1314 1318	3 PH 220V	TOP AUGER	5	13.2	214	125.4	250	C163B	60
		BOT. AUGER	5	13.2				C163B	60
		TOP FAN	10 TO 12	33				366B	60
		MID. FAN	10 TO 12	33				366B	60
		BOT. FAN	10 TO 12	33				366B	60
		(2) AUXILIARY	(2) 10	52				C303B	*
	3 PH 440V	TOP AUGER	5	6.6	112	62.7	200	C867A	60
		BOT. AUGER	5	6.6				C867A	60
		TOP FAN	10 TO 12	16.5				C180B	60
		MID. FAN	10 TO 12	16.5				C180B	60
		BOT. FAN	10 TO 12	16.5				C180B	60
		(2) AUXILIARY	(2) 10	26				C163B	*
	1 PH 230V	TOP AUGER	7.5	31	318	206	400	C330B	100
		BOT. AUGER	7.5	31				C330B	100
		TOP FAN	10 TO 12	48				F614B	100
		MID. FAN	10 TO 12	48				F614B	100
		BOT. FAN	10 TO 12	48				F614B	100
		(2) AUXILIARY	(2) 7.5	62				C330B	*
1322	3 PH 220V	TOP AUGER	7.5	20	260	139	350	C228B	90
		BOT. AUGER	7.5	20				C228B	90
		TOP FAN	10 TO 12	33				C366B	60
		MID. FAN	10 TO 12	33				C366B	60
		BOT. FAN	10 TO 12	33				C366B	60
		(2) AUXILIARY	(2) 15	78				C400B	*
	3 PH 440V	TOP AUGER	7.5	10	135	69.5	200	C137B	60
		BOT. AUGER	7.5	10				C137B	60
		TOP FAN	10 TO 12	16.5				C180B	60
		MID. FAN	10 TO 12	16.5				C180B	60
		BOT. FAN	10 TO 12	16.5				C180B	60
		(2) AUXILIARY	(2) 15	39				C228B	*
	1 PH 230V	TOP AUGER	1	6.5	151	61	200	C867A	50
		BOT. AUGER	1	6.5				C867A	50
		FAN	10 TO 12	48				F614B	60
		(2) AUXILIARY	(2) 7.5	62				C330B	*
160AB	3 PH 220V	TOP AUGER	1	3.4	102	39.8	150	C419A	60
		BOT. AUGER	1	3.4				C419A	60
		FAN	10 TO 12	33				C366B	60
		(2) AUXILIARY	(2) 7.5	40				C228B	*
	3 PH 440V	TOP AUGER	1	1.7	56	19.9	150	C239A	60
		BOT. AUGER	1	1.7				C239A	60
		FAN	10 TO 12	16.5				C180B	60
		(2) AUXILIARY	(2) 7.5	20				C137B	*

*AUXILIARIES RUN THROUGH LOAD AND UNLOAD BREAKERS

ELECTRICAL LOAD INFORMATION

DRYER MODEL NUMBER	VOLTAGE	MOTOR	H.P.	FULL LOAD AMPS	MAX. AMPS WITH AUXILIARIES	MINIMUM AMPS	RECOMMENDED SERVICE IN AMPS	RELAY HEATER STRIPS	BRANCH BREAKER IN AMPS
210AB	1 PH 230V	TOP AUGER	2	14	169	76	225	C163B	60
		BOT. AUGER	2	14				C163B	60
		FAN	10 TO 12	48				F614B	100
		(2) AUXILIARY	(2) 7.5	62				C330B	*
	3 PH 220V	TOP AUGER	2	6.2	102	40.4	150	C778A	50
		BOT. AUGER	2	6.2				C778A	50
		FAN	10	28				C330B	60
		(2) AUXILIARY	(2) 7.5	40				C228B	*
	3 PH 440V	TOP AUGER	2	3.1	56	20.2	150	C379A	60
		BOT. AUGER	2	3.1				C379A	60
		FAN	10	14				C180B	60
		(2) AUXILIARY	(2) 7.5	20				C137B	*
300AB	1 PH 230V	TOP AUGER	3	17.7	212	113.4	300	C214B	60
		BOT. AUGER	3	17.7				C214B	60
		FAN	10 TO 17	78				F914B	100
		(2) AUXILIARY	(2) 7.5	62				C330B	*
	3 PH 220V	TOP AUGER	3	8.6	121	56.2	175	C113B	60
		BOT. AUGER	3	8.6				C113B	60
		FAN	15	39				C400B	60
		(2) AUXILIARY	(2) 7.5	40				C228B	*
	3 PH 440V	TOP AUGER	3	4.3	65	28.1	150	C526A	60
		BOT. AUGER	3	4.3				C526A	60
		FAN	15	19.5				C228B	60
		(2) AUXILIARY	(2) 7.5	20				C137B	*
375AB	1 PH 230V	TOP AUGER	3	17.7	212	113.4	300	C214B	60
		BOT. AUGER	3	17.7				C214B	60
		FAN	10 TO 17	78				F914B	100
		(2) AUXILLARY	(2) 7.5	62				C330B	*
	3 PH 220V	TOP AUGER	3	8.6	121	56.2	175	C113B	60
		BOT. AUGER	3	8.6				C113B	60
		FAN	15	39				C400B	60
		(2) AUXILIARY	(2) 7.5	40				C228B	*
	3 PH 440V	TOP AUGER	3	4.3	65	28.1	150	C526A	60
		BOT. AUGER	3	4.3				C526A	60
		FAN	15	19.5				C228B	60
		(2) AUXILIARY	(2) 7.5	20				C137B	*
400AB	1 PH 230V	TOP AUGER	5	26	231	130	350	C303B	100
		BOT. AUGER	5	26				C303B	100
		FAN	10 TO 17	78				F914B	100
		(2) AUXILIARY	(2) 7.5	62				C330B	*
	3 PH 220V	TOP AUGER	5	13.2	145	65.4	200	C163B	60
		BOT. AUGER	5	13.2				C163B	60
		FAN	15	39				C400B	60
		(2) AUXILIARY	(2) 10	52				C303B	*
	3 PH 440V	TOP AUGER	5	6.6	78	32.7	150	C867A	60
		BOT. AUGER	5	6.6				C867A	60
		FAN	15	19.5				C228B	60
		(2) AUXILIARY	(2) 10	26				C163B	*

*AUXILIARIES RUN THROUGH LOAD AND UNLOAD BREAKERS

ELECTRICAL LOAD INFORMATION

DRYER MODEL NUMBER	VOLTAGE	MOTOR	H.P.	FULL LOAD AMPS	MAX. AMPS WITH AUXILIARIES	MINIMUM AMPS	RECOMMENDED SERVICE IN AMPS	RELAY HEATER STRIPS	BRANCH BREAKER IN AMPS
	1 PH 230V	TOP AUGER	5	26	252	148	350	C303B	100
		BOT. AUGER	5	26				C303B	100
		(2) FANS	(2) 10 TO 12	96				F614B	100
		(2) AUXILIARY	(2) 7.5	62				C330B	*
415AB	3 PH 220V	TOP AUGER	5	13.2	165	82.4	225	C163B	60
		BOT. AUGER	5	13.2				C163B	60
		(2) FANS	(2) 10	56				C330B	60
		(2) AUXILIARY	(2) 10	52				C303B	*
	3 PH 440V	TOP AUGER	5	6.6	82	41.2	150	C867A	60
		BOT. AUGER	5	6.6				C867A	60
		(2) FANS	(2) 10	28				C180B	60
		(2) AUXILIARY	(2) 10	26				C163B	*
	1 PH 230V	TOP AUGER	7.5	31	332	218	400	C330B	100
		BOT. AUGER	7.5	31				C330B	100
		(2) FANS	(2) 10 TO 17	156				F914B	100
		(2) AUXILIARY	(2) 7.5	62				C330B	*
600AB	3 PH 220V	TOP AUGER	7.5	20	235	118	300	C228B	90
		BOT. AUGER	7.5	20				C228B	90
		(2) FANS	(2) 15	78				C400B	60
		(2) AUXILIARY	(2) 15	78				C400B	*
	3 PH 440V	TOP AUGER	7.5	10	123	59	200	C137B	60
		BOT. AUGER	7.5	10				C137B	60
		(2) FANS	(2) 15	39				C228B	60
		(2) AUXILIARY	(2) 15	39			C228B	*	

*AUXILIARIES RUN THROUGH LOAD AND UNLOAD BREAKERS

AIRSTREAM

It's really smart.

A Division of **GSI**

1004 E. Illinois St., Box 20
Assumption, IL 62510-0020
phone: 217-226-4421
fax: 217-226-4420