

CE Compliant Vane Axial Fan Installation and Operation

Model #: _____

Owner's Manual - Original Instructions

PNEG-010CE

Date: 12-13-12

GSI GROUP



PNEG-010CE

Fan Check List

1. All wire connections.
2. Tip clearance on blade.
3. Fan blade torqued to torque specs.
4. Grill guard in place and tight.
5. Fuse in place, extra fuse provided.
6. Motor rotation correct.
7. Contactor engages properly.
8. Running amperage.
9. Vibration.
10. All fasteners tight.
11. Indicator light.
12. All decals and serial number tag.
13. Aesthetic appearance.
14. Manual.

Tester Signature: _____

Date: _____

Record in the space provided below the Model # and Serial # of this product. These numbers are found on the Model and Serial Tags located on the outside of the unit.

Model #: _____

Serial #: _____

Keep these numbers for future reference.



The GSI Group declares that

GSI Vane Axial Fans

Ref #	Description
AF-1.5-6G	Fan: 18" 1-1/2 HP 3 Phase 380V
AF-1.5-7G	Fan: 18" 1-1/2 HP 3 Phase 415V
AF-10-6G	Fan: 24" 10 HP 3 Phase 380V
AF-10-7G	Fan: 24" 10 HP 3 Phase 415V
AF-12-6G	Fan: 12" 1 HP 3 Phase 380V
AF-12-7G	Fan: 12" 1 HP 3 Phase 415V
AF-14-6G	Fan: 14" 1 HP 3 Phase 380V
AF-14-7G	Fan: 14" 1 HP 3 Phase 415V
AF-158-6G	Fan: 28" 15 HP 3 Phase 380V
AF-158-7G	Fan: 28" 15 HP 3 Phase 415V
AF-3-6G	Fan: 18" 3 HP 3 Phase 380V
AF-3-7G	Fan: 18" 3 HP 3 Phase 415V
AF-7-6G	Fan: 24" 7 HP 3 Phase 380V
AF-7-7G	Fan: 24" 7 HP 3 Phase 415V

Meet the following clauses of the Essential Requirements of the Machinery Directive 2006/42/EC.

- 1.1.2 and sub-clauses principles of safety integration
- 1.3.2 Risk of break-up during operation
- 1.3.7 Risk related to moving parts
- 1.3.8 Choice of protection against risks arising from moving parts
 - 1.3.8.1 Moving transmission parts
 - 1.3.8.2 Moving parts involved in the process (*Installer has responsibility to ensure complete compliance with this clause, as per manual.*)
- 1.3.9 Risks of uncontrolled movements
- 1.4 Required characteristics of guards and protective devices
 - 1.4.1 General requirements
 - 1.4.2 Special requirements for guards
 - 1.4.2.1 Fixed guards
- 1.5.4 Errors of fitting
- 1.5.5 Extreme temperatures



**CE Declaration of Incorporation
EC MACHINERY DIRECTIVE
2006/42/EC**

1004 East Illinois Street, Assumption, IL, 62510, USA

+1 217 226 4429

- 1.5.6 Fire
- 1.5.7 Explosion
- 1.5.8 Noise
- 1.5.9 Vibrations
- 1.5.13 Emissions of hazardous materials and substances
- 1.6 Maintenance
 - 1.6.1 Machinery maintenance
 - 1.6.4 Operator intervention
- 1.7 Information
 - 1.7.1 Information and warnings on the machinery
 - 1.7.1.1 Information and information devices
 - 1.7.2 Warning of residual risks
 - 1.7.4 Instructions
 - 1.7.4.1 General principles for the drafting of instructions
 - 1.7.4.2 Contents of the instructions but not inclusive of sub-clause (u)
 - 1.7.4.3 Sales literature

This declaration applies only to the mechanical elements of the above machines and does not imply conformity by any other items of equipment fitted to or connected with the above machines. The equipment above must not be put into service until the machinery into which it is to be incorporated has been declared in conformity with the provisions of all relevant Directives, nor until these components have been assembled in the manner recommended in the manufacturers instructions.

Signed :

Name: Robb Williams

Position: Engineering Manager GSI Conditioning Products

Date: December 14, 2012

Contents

Chapter 1 Introduction	6
Chapter 2 Safety	7
Safety Guidelines	7
Safety Instructions	8
Minimum Safety Requirements	9
Chapter 3 Decals	12
International Decals	12
Roof Damage Warning and Disclaimer	13
Chapter 4 Fan Specifications	14
Airflow	14
Sound	15
Dimensions	16
Chapter 5 Installation Instructions	17
Fan Base Requirements	17
Fan Placement	18
Electrical Installation	18
Electrical Control System	19
Wiring Motor	20
Final Check	21
Start-Up	21
Chapter 6 Maintenance	22
Lubrication and Bearings	22
Fan Wheel Removal and Refitting	22
Fan Blade Removal and Installation	22
Removal	23
Installation	23
Chapter 7 Fan Service	24
Fan Blade Inspection and Maintenance	24
Fan Motor Removal and Installation	24
Chapter 8 Parts List	25
Vane Axial Fan Parts	25
Chapter 9 Warranty	27

1. Introduction

READ THIS MANUAL carefully to learn how to properly use and install equipment. Failure to do so could result in personal injury or equipment damage.

INSPECT the shipment immediately upon arrival. The customer is responsible for ensuring that all quantities are correct. The customer should report and note any damage or shortage on the bill of lading to justify their claim to the transport company.

THIS MANUAL SHOULD BE CONSIDERED a permanent part of your equipment and should be easily accessible when needed.

This warranty provides you the assurance that the company will back its products when defects appear within the warranty period. In some circumstances, the company also provides field improvements, often without charge to the customer, even if the product is out of warranty. Should the equipment be abused, or modified to change its performance beyond the factory specifications, the warranty will become void and field improvements may be denied.

Safety Guidelines

This manual contains information that is important for you, the owner/operator, to know and understand. This information relates to protecting **personal safety** and **preventing equipment problems**. It is the responsibility of the owner/operator to inform anyone operating or working in the area of this equipment of these safety guidelines. To help you recognize this information, we use the symbols that are defined below. Please read the manual and pay attention to these sections. Failure to read this manual and its safety instructions is a misuse of the equipment and may lead to serious injury or death.



This is the safety alert symbol. It is used to alert you to potential personal injury hazards. Obey all safety messages that follow this symbol to avoid possible injury or death.



DANGER indicates a hazardous situation which, if not avoided, will result in death or serious injury.



WARNING indicates a hazardous situation which, if not avoided, could result in death or serious injury.



CAUTION, used with the safety alert symbol, indicates a hazardous situation which, if not avoided, could result in minor or moderate injury.



NOTICE is used to address practices not related to personal injury.

2. Safety

Safety Instructions

Our foremost concern is your safety and the safety of others associated with this equipment. We want to keep you as a customer. This manual is to help you understand safe operating procedures and some problems that may be encountered by the operator and other personnel.

As owner and/or operator, it is your responsibility to know what requirements, hazards, and precautions exist, and to inform all personnel associated with the equipment or in the area. Safety precautions may be required from the personnel. Avoid any alterations to the equipment. Such alterations may produce a very dangerous situation where **SERIOUS INJURY** or **DEATH** may occur.

This equipment shall be installed in accordance with the current installation codes and applicable regulations, which should be carefully followed in all cases. Authorities having jurisdiction should be consulted before installations are made.

Follow Safety Instructions

Carefully read all safety messages in this manual and safety signs on your machine. Keep signs in good condition. Replace missing or damaged safety signs. Be sure new equipment components and repair parts include the current safety signs. Replacement safety signs are available from the manufacturer.

Learn how to operate the machine and how to use controls properly. Do not let anyone operate without instruction.

Keep your machinery in proper working condition. Unauthorized modifications to the machine may impair the function and/or safety and affect machine life.

If you do not understand any part of this manual or need assistance, contact your dealer.

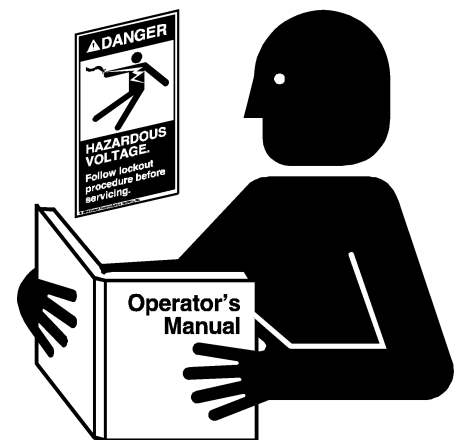

Read and Understand Manual

Prepare for Emergencies

Be prepared if fire starts.

Keep a first aid kit and fire extinguisher handy.

Keep emergency numbers for doctors, ambulance service, hospital, and fire department near your telephone.

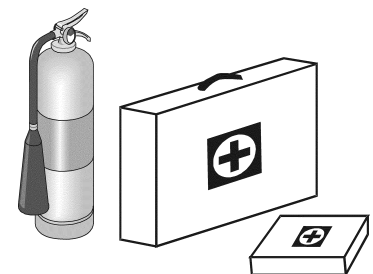

Keep Emergency Equipment Quickly Accessible

Wear Protective Clothing

Wear close-fitting clothing and safety equipment appropriate to the job.

Remove all jewelry.

Tie long hair up and back.

Wear safety glasses at all times to protect eyes from debris.

Wear gloves to protect your hands from sharp edges on plastic or steel parts.

Wear steel-toed boots to help protect your feet from falling debris. Tuck in any loose or dangling shoestrings.

A respirator may be needed to prevent breathing potentially toxic fumes and dust.

Wear a hard hat to help protect your head.

Wear appropriate fall protection equipment when working at elevations greater than six feet (6').

Eye Protection

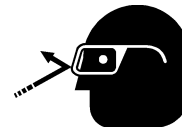

Gloves



Steel-Toed Boots



Respirator



Hard Hat



Fall Protection



Minimum Safety Requirements



Incorrect use of fans can be extremely dangerous. Rotating impellers and shafts can cause serious injury and kill.

Correct Use

1. The fan is for ventilating whole agricultural seeds and grains inside a grain bin or other grain store. Any other use is prohibited and may result in injury or equipment damage.
2. These fans are to be permanently installed and are not designed to be portable.
3. The outlet of the fan is supplied unguarded, being designed to be directly coupled to a transition duct, eliminating scope for personnel access. Never operate the fan with the outlet exposed.
4. If the fan is fitted to a duct into which personnel have access, the user has responsibility to supply and fit an outlet guard, which comprises the same part number as the inlet guard, available through GSI or your dealer.

2. Safety

5. The installer and operator have responsibility to ensure the final installation is in accordance with all the safety requirements outlined in this manual and fulfils the Essential Requirements of the Machinery Directive 2006/42/EC.
6. Never use the fan with any guards removed.
7. Never enter the grain bin or store unless the power supply to the fan and all other equipment is OFF, TAGGED and LOCKED. (See [Figure 2A.](#))



Figure 2A

8. Never allow an untrained person less or one less than 18 years old to operate the fan.
9. Never allow someone under the influence of alcohol or drugs to operate the equipment.
10. Never modify the fan from it's original specification.
11. The inlet to the fan generates suction. Never work around the inlet to the fan when it is running. Keep loose hair tied back and avoid loose clothing.

Electrical Safety Equipment

Please refer to [Chapter 5 on Page 19](#) for electrical control requirements.

1. All electrical installation and design must be carried out by a qualified electrical engineer and in accordance with EU Directives and standards and in accordance with local laws and codes.
2. The electrical supply must include a properly designed protective earth system (PE).
3. The motor must be connected to protective earth at the terminal provided.
4. The control system must include short circuit protection and over current protection.
5. It is recommended to provide earth leakage protection, such as residual current device (RCD) or residual current circuit breaker (RCCB) to provide automatic disconnection from the power in the event of a fault.

Sound

1. Sound levels generated by the fans can be harmful to hearing.
2. Never work around a fan whilst it is running.
3. If you need to be around the fan whilst it is running, wear suitable ear defenders.

Safe Maintenance

1. The fan must always be LOCKED off to prevent inadvertent re-start when undertaking any maintenance.
2. Even when off, the fan wheel can free-wheel under air movement from outside or other fans attached to the same air space. To prevent injury, use a piece of timber to choc the wheel.
3. Remove wheel choc and replace all guards before re-starting.

3. Decals

Below are the safety warning decals that should be fitted to the fan. These warn of residual risks and required safety measures and must remain intact, legible at all times. If any decals have become damaged or unreadable, please contact GSI or your dealer for free replacements.

International Decals

International, translated versions of the decals fitted to the equipment are available as part of the Language Pack that was supplied with the product. If you need further copies or a different language, please contact GSI or you dealer.

The international decals have been designed to be placed directly over the USA standard versions. Normally these will be factory fitted, but if you need to change them, please refer to the decal cross reference sheet, provided with the Language Pack and the decal locations given in the user's manual.

 <p>Ear protection must be worn in this area</p> <p>DC-2166</p>	 <p>Danger Automatic rotating fan blades</p> <ol style="list-style-type: none">1. Do not operate with guards removed.2. Isolate and lock from power before removing guards.3. Replace all guards before reconnection to power. <p>DC-2162</p>
 <p>Danger High voltage</p> <ol style="list-style-type: none">1. Isolate and lock from power before removing guards or opening enclosure.2. Replace all guards and lock enclosure before reconnecting to power. <p>DC-2163</p>	 <p>ROTATION ROTATION</p> <p>DC-219</p>  <p>AIRFLOW AIRFLOW</p>  <p>CIRCULATION D'AIR CIRCULATION D'AIR</p> <p>DC-1971</p>

Roof Damage Warning and Disclaimer

The manufacturer does not warrant any roof damage caused by excessive vacuum or internal pressure from fans or other air moving systems. Adequate ventilation and/or “makeup air” devices should be provided for all powered air handling systems. The manufacturer does not recommend the use of downward flow systems (suction). Severe roof damage can result from any blockage of air passages. Running fans during high humidity/cold weather conditions can cause air exhaust or intake ports to freeze.



CAUTION

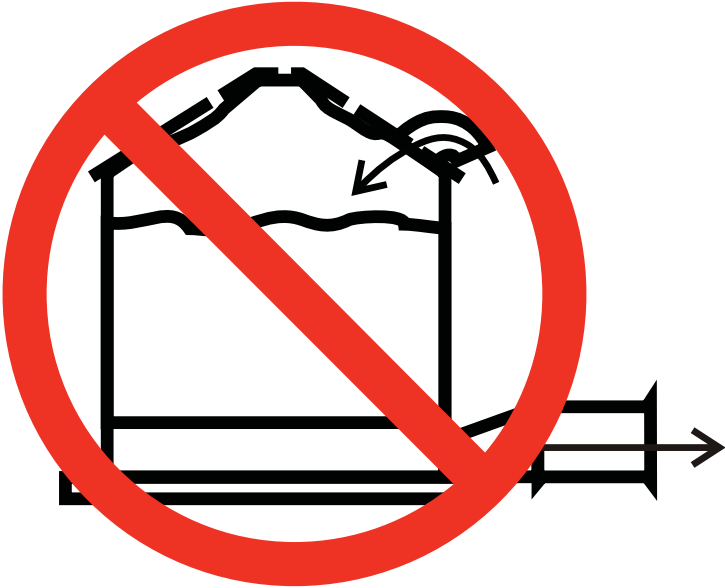

Excessive vacuum (or pressure) may damage roof. Use positive aeration system. Make sure all roof vents are open and unobstructed. Start roof fans when supply fans are started. Do not operate when conditions exist that may cause roof vent icing.

GSI Group, Inc. 217-226-4421DC-969

4. Fan Specifications

Airflow

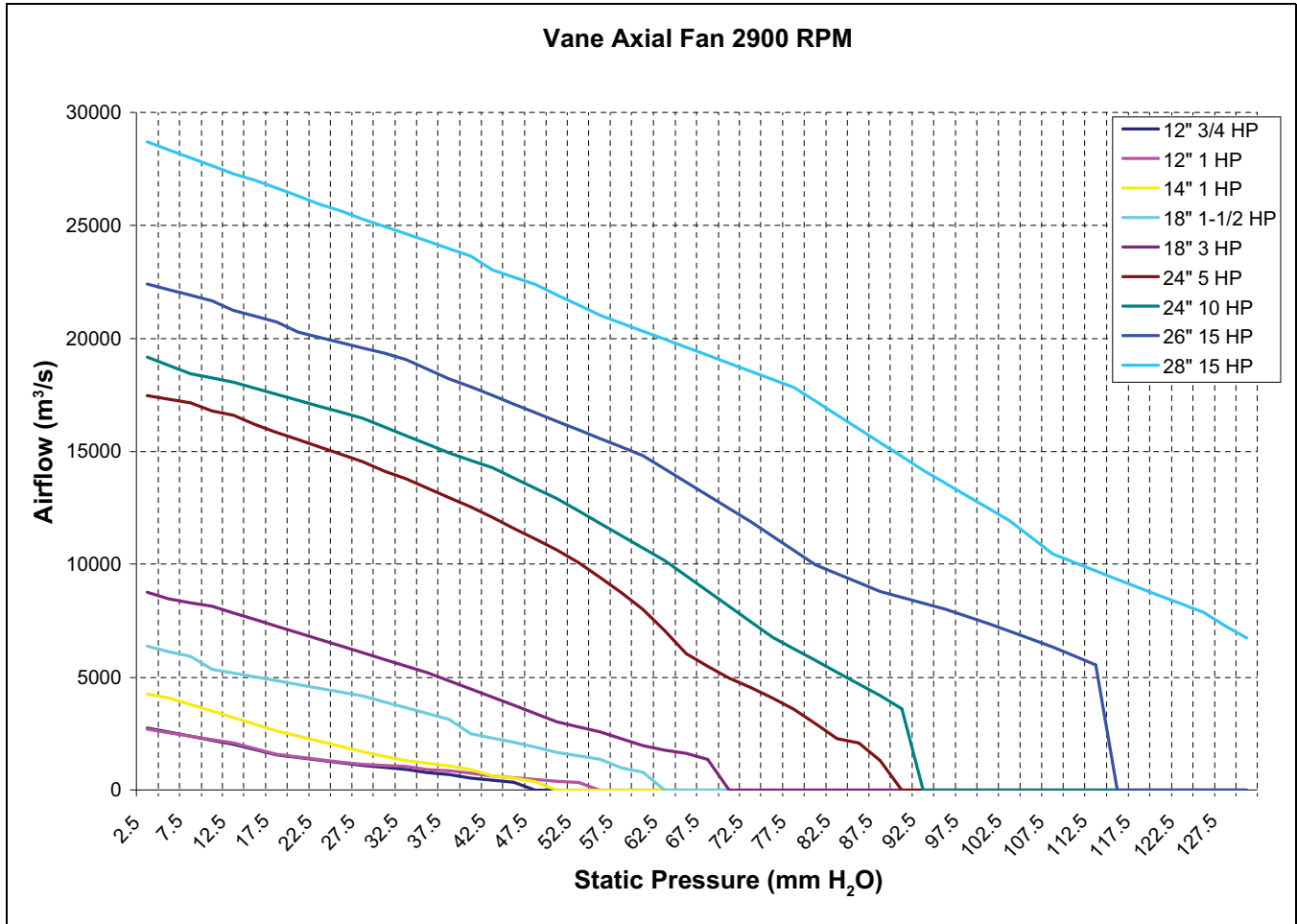

Figure 4A Vane Axial Fan Performance

Sound

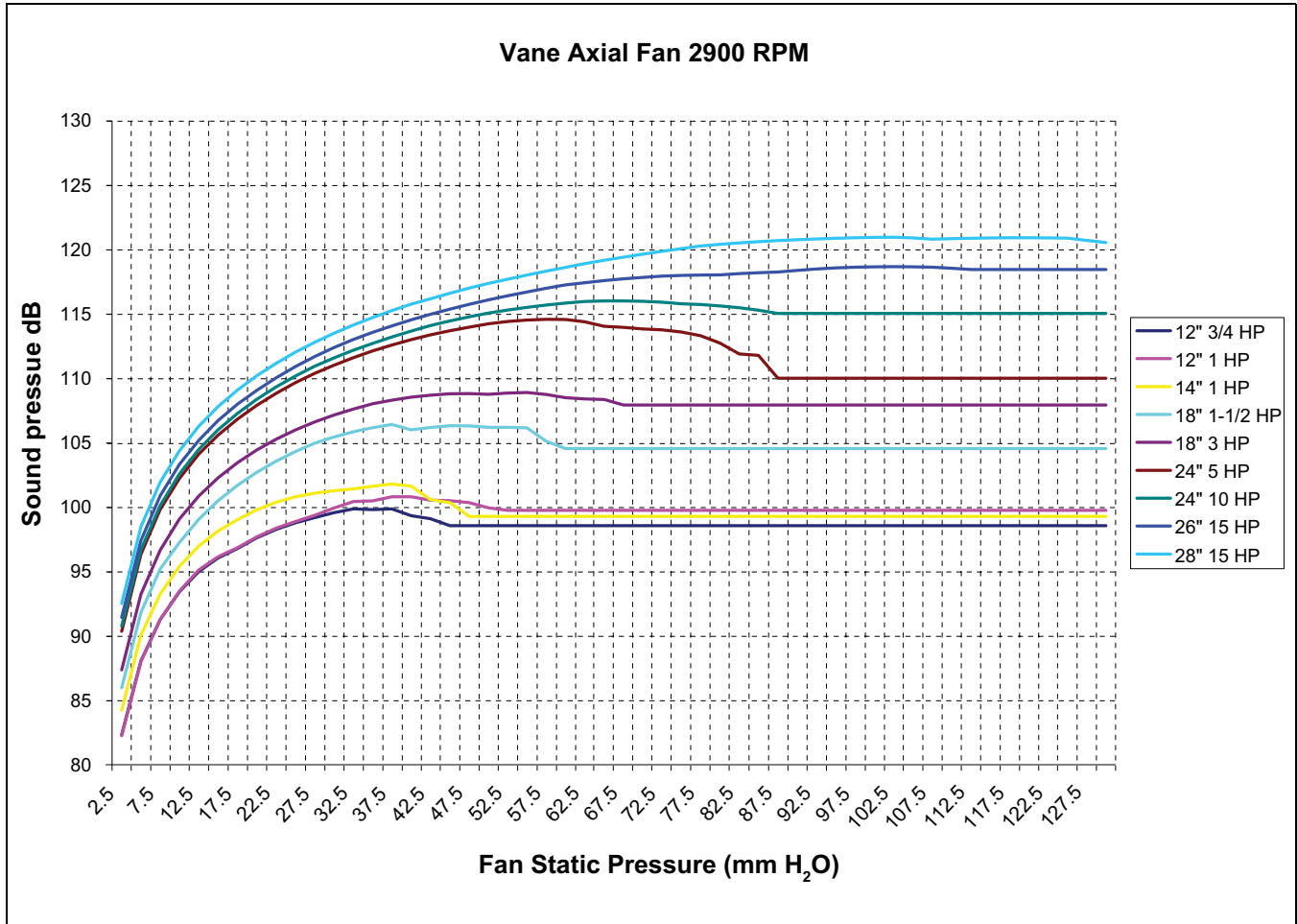

Figure 4B Centrifugal Fan Sound Curves (Calculated with Open Outlet)

Use the table [below](#) to determine the number of GSI roof vents (0.16 m² free area). Also minimum inlet area, for fans enclosed in a fan house:

Minimum GSI Roof Vents per Fan

Fan Model	Maximum Airflow (m ³ /s)	Minimum Number of Roof Vents	Minimum Inlet Area (m ²)
12" 3/4 HP	0.77	1	0.1
12" 1 HP	0.75	1	0.1
14" 1 HP	1.19	2	0.2
18" 1-1/2 HP	1.78	3	0.3
18" 3 HP	2.44	4	0.4
24" 5 HP	4.86	7	0.7
24" 10 HP	5.33	7	0.7
26" 15 HP	6.23	8	0.8
28" 15 HP	7.98	10	1

4. Fan Specifications

Dimensions

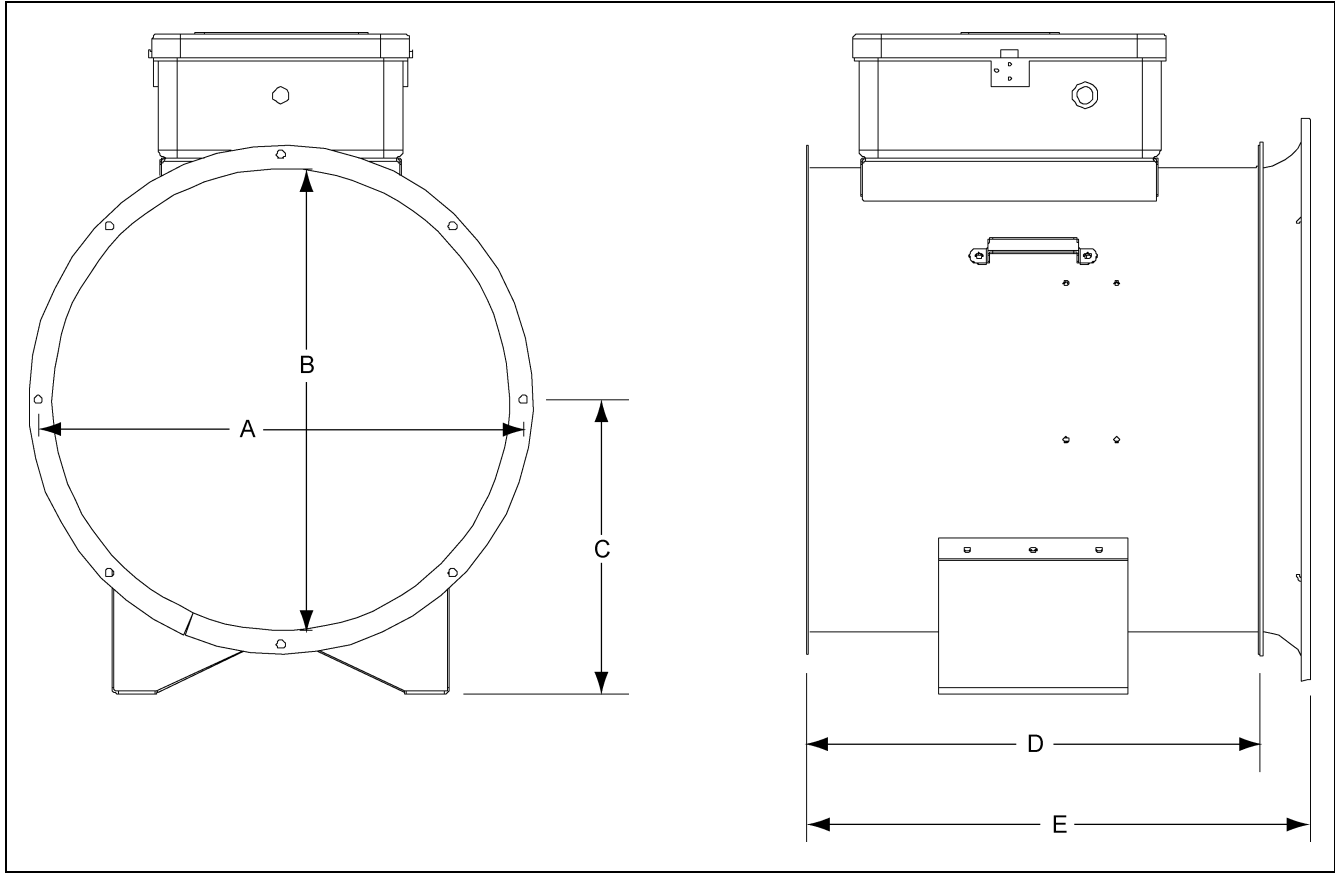

Figure 4C

Fan Dimensions (mm)

Fan	12" 0.75 kW	12" 0.575 kW	14"	18" 1.1 kW/2.2 kW	24"	26"	28"
A	343	330	387	489	654	705	762
B	311	302	362	464	616	675	718
C	192	192	276	302	395	429	460
D	410	410	411	432/508	610	610	610
E	-	-	-	-	679	-	679

Fan Base Requirements

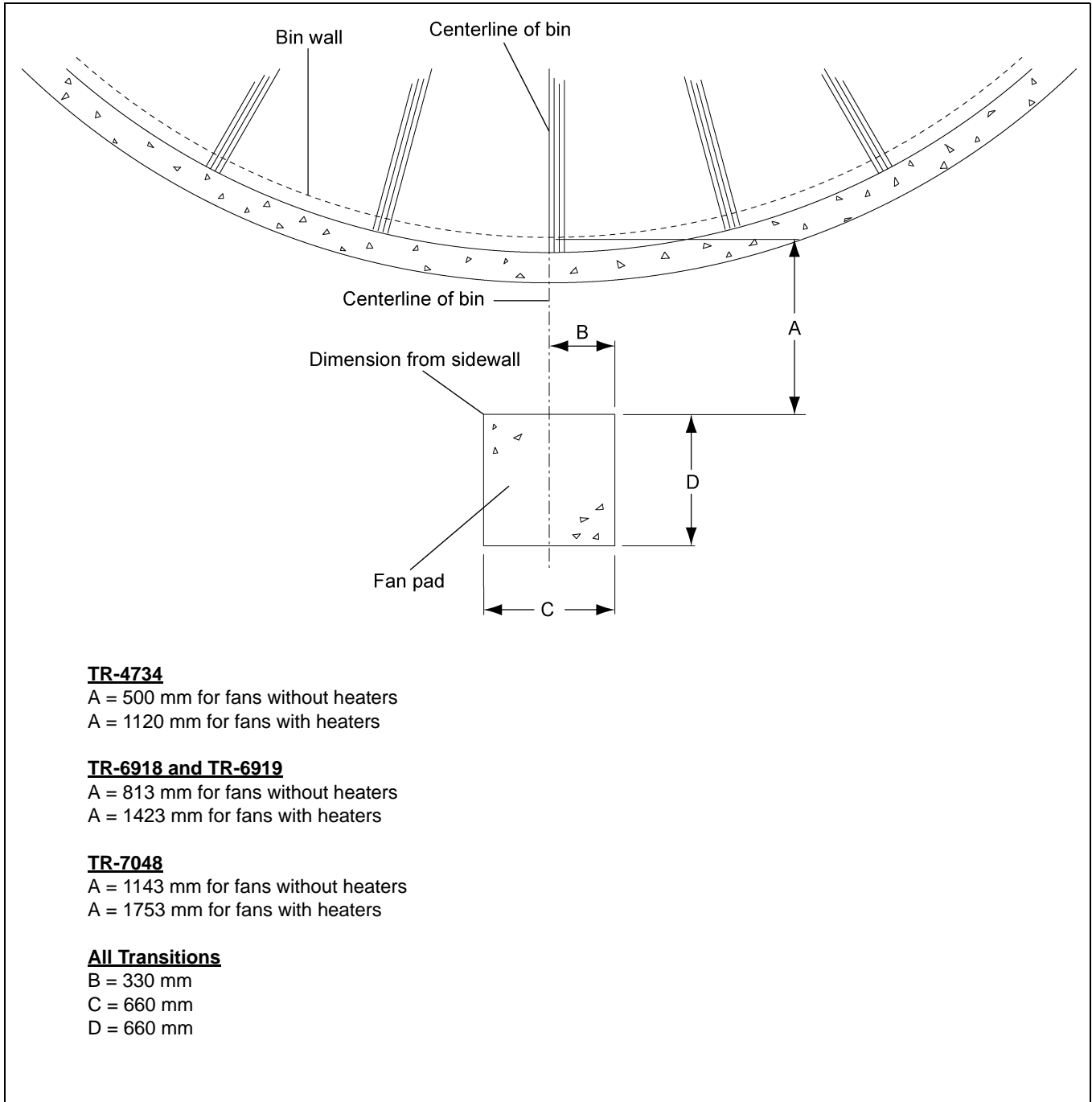

Figure 5A Fan Base Dimensions and Location per GSI Transition Duct (mm)

5. Installation Instructions

Fan Placement

1. Fan base must be flat and level to ensure smooth fan operation.
2. To connect the fan to the bin, a steel transition duct is required. Consult GSI or your dealer for the correct duct for the fan and bin.
3. Remove packaging materials and inspect fan for any shipping damages. Report these at once to the shipper.
4. Check all fasteners on the fan to make sure they are tight. (Fasteners may loosen during shipment.)
5. Tighten any loose fasteners, check for proper clearance and re-tighten.
6. Check all electrical connections that may have loosened during shipment.
7. Rotate the fan wheel. Wheel should rotate freely and should not make contact with the housing sides or inlet cone.
8. Place fan in proper location on the fan pad. Attach fan to transition duct and seal connection with caulk.
9. Check all joints and seams around the lower part of the bin. Verify that these are well sealed to prevent air leakage from the bin plenum. Inspect the transition duct as well. Seal any leaks that may be present to prevent air losses that reduce fan efficiency.
10. Level fan front to back and left to right with a spirit level. The feet should be shimmed so that, when level, all feet touch the pad. Fans not resting on support legs may have excess vibration which can lead to premature wear and tear on fan components.
11. Do not fix the fan to the base. Fix only to the transition duct.

Electrical Installation

3 Phase Power Requirements

Motor Current Requirements (A)

Fan Power (kW)	0.56	0.75	1.13	1.50	2.25	3.75	7.50	11.25
Voltage (V)								
380	1.2	1.6	2.3	3.1	4.6	7.6	15.2	22.8
400	1.1	1.5	2.2	2.9	4.4	7.3	14.5	21.7
415	1.1	1.4	2.1	2.8	4.2	7.0	14.0	20.9
440	1.0	1.4	2.0	2.7	4.0	6.6	13.2	19.7

NOTE: The [Above](#) table does not allow for motor starting currents.

Electrical Control System

Fans are supplied without any controls. A correctly designed control system is required. In particular:

1. Fan motor starter to minimize starting currents. (Check when ordering fan that the motor supplied is suitable for the chosen method of starting.)
2. For service and maintenance purposes, the equipment can be locked out with no risk if inadvertent re-start.

The following items are the minimum required when making electrical connections to the fan:

1. Main power supply with protective earth, over-current and short circuit protection.

2. Main electrical disconnect.



- a. Wired to disconnect all electrical power to the fan and other associated equipment.
- b. Lockable.

3. Service disconnect.



- a. Wired to break all electrical power to the fan motor.
- b. Lockable.

4. Emergency stop.



- a. Wired to stop the fan motor (and any other associated equipment) immediately when pressed.
- b. Must remain engaged until manually disengaged.

5. Start/Stop controls.



- a. Recessed start push button labelled 1.
- b. Non-recessed stop push button labelled 0.
- c. Motor starter, short circuit protection and motor overload.
- d. Control must be designed to default to OFF after a power interruption. (Eg: Self maintained relay.)
- e. The fan **MUST NOT** be able to immediately re-start following re-establishment of power.

NOTE: *Electrical controls located on the side of the bin will be subject to significant water due to run-off from the roof during rain. These controls should be rated for out door use (minimum IP65) and will also benefit from being covered to protect from direct water.*

5. Installation Instructions

Wiring Motor

- The motor may be 3, 6, 9 or 12 wire, with wires bundled loose inside the connection box.
NOTE: 3 and 9 wire motors cannot be started 'Star-Delta'.
- Each wire is individually numbered.
- Refer to wiring schematic *below* provided inside the motor terminal box for correct wiring. This will depend on the chosen starting method.
- Note that motors may be multi-voltage. Check motor rating plate for the required voltage.
- Ensure the motor is correctly connected to the protective earth (PE) system with the power supply. The earth terminal is inside the motor connection box.
- Make connections using connectors approved for use in the region, ensuring the connections are correct for the voltage and starting method.
- Check the full load current for the motor at the supply frequency and voltage and set the motor overload relay at or below this value.

GSI Part #	Baldor Part #	Motor Power	380V 50 Hz Start Connections	380V 50 Hz Run Connections
FH-6980	AFM3529-M16	1 HP/0.75 kW	These motors cannot be started Star-Delta. Use other form of Soft Start or Direct-On-Line.	
FH-6258	AFM3532-M16B	3 HP/2.25 kW		
		5 HP/3.75 kW		
FH-6436	UCM713-M16B	7.5HP/5.63 kW		
FH-6584	37E831X884G1	15 HP/11.25 kW		
Swap any two (2) line connections to reverse motor direction.				

GSI Part #	Baldor Part #	Motor Power	415V 50 Hz Start Connections	415V 50 Hz Run Connections
F-7187	AFM3532-M16B	3 HP/2.25 kW	These motors cannot be started Star-Delta. Use other form of Soft Start or Direct-On-Line.	
FH-5650-7	37E831X884G1	15 HP/11.25 kW		
Swap any two (2) line connections to reverse motor direction.				

Final Check

Ensure the power to the fan is OFF, LOCKED and TAGGED before final checks.



Figure 5B

1. Check the fan wheel can rotate freely and maintains an even gap to the inlet cone.
2. Check to make sure all safety guards are in place and not damaged. Replace damaged parts.
3. Check to make sure all decals are visible and not damaged. Replace damaged decals.
4. Check to make sure all control boxes are closed and no wiring is exposed.
5. With all guards fitted, start the fan to check correct impeller rotation. Check against rotation decal on inlet side of fan. Fan should rotate counterclockwise when viewed through the inlet guard. To reverse rotation, switch any two (2) phases.

Start-Up

1. Start the fan and allow it to run, checking for smooth, quiet running.
2. Check each phase with a meter for correct phase voltage and equal phase current.
3. Voltage drop at the motor should be no greater than 5% of nominal voltage.
4. Check the fan legs remain all in contact with the base and the lock nuts are tight.

6. Maintenance

1. Where the fan is out of use for long periods, GSI recommend running it for 20 minutes per month to help reduce pre-harvest service issues.
2. Do not allow debris to build-up on the impeller. If required, with the power LOCKED OFF remove the inlet guard and cone and clean the impeller.
3. Check the impeller for cracks or damage. A damaged impeller can run out of balance and result in wider damage to the fan, motor and bearings.
4. Check the grille over the cooling fan to the motor to ensure it remains clear.

Lubrication and Bearings

Type of Annual Usage	1450 RPM - NEMA Frame Size			2900 RPM - NEMA Frame Size		
	Up to 280 incl.	Over 280 to 360 incl.	Over 360	Up to 280 incl.	Over 280 to 360 incl.	Over 360
Continuous Normal Duty*	9500 Hrs	7400 Hrs	3500 Hrs	3600 Hrs	2200 Hrs	2200 Hrs
Continuous Severe Duty**	4750 Hrs	3700 Hrs	1750 Hrs	1800 Hrs	1100 Hrs	1100 Hrs
Seasonal Service Motor (Idle 6 Months)	Grease at the beginning of season and then follow the interval above.					

- Use suitable high temperature roller bearing grease.
- Clean all grease fittings.

Fan Wheel Removal and Refitting



Always disconnect and lock out power before working on or around fan.

Fan Blade Removal and Installation

The fan blade is secured to the motor shaft by the use of a taper-lock bushing, motor shaft key and cap screws. The size, quantity and torque of cap screws required will depend on the model of the fan.



Although the taper-lock method of retaining the blade onto the motor shaft is very simple and obvious, it is essential that the following points be read carefully and fully understood, as improper installation can result in serious or fatal injury caused by a loose, fast flying blade.

THREADED BUSHING HOLES: The threaded holes within the bushing are provided for disassembly purposes only. Do not attempt to use these holes for re-assembly, as they will not allow the parts to become locked onto the shaft, thereby causing an extremely hazardous operating condition.

CLEARANCE HOLES: When re-assembling parts, the cap screws must be installed through the UNTAPPED.

Removal

1. LOCK OUT THE MAIN POWER SUPPLY and remove the fan guard and venturi.
2. Remove the three (3) cap screws from the clearance holes in taper-lock bushing. Inspect for thread damage and set aside for later re-installation (do not use these bolts for [Step 3](#), bushing removal).
3. Install two (2) grade 5 (or better) cap screws into the THREADED HOLES in the bushing and turn them in by hand until they bottom against the front surface of the blade. These cap screws should not be used for re-assembly, as some thread distortion could occur during the removal operation. Grade 5 screws are marked with three (3) 120° spokes on the head and are more durable than low strength unmarked bolts.

NOTE: *Do not attempt to use low strength (unmarked) bolts to remove the bushing, as the bolts may break off.*

4. Block blade to prevent it from turning and GRADUALLY TURN IN THE CAP SCREWS (up to 1/4 turn at time), until the blade breaks loose from the bushing and motor shaft. Carefully remove bushing and blade. (With the blade free from the bushing, a blade puller can be used to pull the bushing off of motor shaft, if required.) Re-attach bushing onto blade to prevent the loss of parts and also to maintain the original alignment of bushing to blade.

Inspect blade and bushing at this time, looking for any cracks, thread or bolt damage, warpage, etc. Consult your dealer or the factory for any questions concerning damage.

Installation

1. Carefully clean motor shaft, key, bushing and bore of blade. MAKE SURE MAIN POWER IS LOCKED OUT and that shaft and key are completely free of rust and burrs. DO NOT lubricate the bushing or cap screws. CHECK AND MAKE SURE ALL MOTOR MOUNT BOLTS ARE PROPERLY TIGHTENED. Before installing the blade, check the following:
 - a. All foreign material should be removed from the blade.
 - b. Carefully inspect the blade weldment and hub casting for damage, cracks or other defects. Contact the factory if there is any question regarding the structural integrity of the blade.
2. Slide blade over motor shaft and locate it as far onto the motor shaft as possible.
3. Align the keyway in the bushing with the key and SLIDE bushing onto motor shaft. Do not attempt to drive the bushing onto the shaft, as it may damage the motor bearings.
4. Rotate the bushing and blade so their key slots are in line and loosely attach the blade to the bushing. MAKE SURE THE CAP SCREWS ARE INSERTED INTO THE UNTHREADED CLEARANCE HOLES IN THE BUSHING. Refer to previous CAUTION note [on Page 22](#). Locate the bushing so it is approximately flush with the end of motor shaft. Make certain that the proper cap screws are used for re-assembly and no damage has occurred to these screws during disassembly. Use only the special type bolts supplied with the original blade.
5. Use a torque wrench and GRADUALLY TIGHTEN the three (3) cap screws (1/4 turn at a time) until the taper bushing becomes fully seated. Refer to the following chart [on Page 24](#) for recommended cap screw tightening torques. DO NOT EXCESSIVELY OVERTIGHTEN THE BUSHING.
6. Turn blade by hand and check it for freedom of rotation and uniform clearance around venturi before re-installing the fan guard.

Fan Blade Inspection and Maintenance

Pre-season inspections should be done on the fan blade to look for the following:

1. Any debris (stalks, bees wings, mud, insects and insect nests) accumulated on the surfaces of the fan blade. Remove these items as they will likely disrupt airflow over the fan airfoils and can potentially cause vibration problems.
2. Inspect the fan blade for any broken, cracked or loose parts. Blade should NOT be operated with broken or loose parts. Contact dealer for determination of the repairs required.



Do not attempt to pull the flange of the bushing flush with the blade hub. A clearance of 1/8" to 1/4" must be maintained between bushing flange and blade hub surface. Blade will loosen and cause damage or injury.

Browning Taper-Lock Bushings Bolt Tightening Torque

Bushing Size	Hex Bolt Size	Torque (Nm)
H	1/4"-20 x 3/4"	10.7
P	5/16"-18 x 1"	21.7

Fan Motor Removal and Installation

In the event of motor failure, remove the motor, as described and take it to the nearest Authorized Service Station. AUTHORIZED SERVICE STATIONS ARE THE ONLY PLACES THAT CAN PROVIDE MOTOR WARRANTY. Motor service and repair at other places will be at owner's expense. If service station determines motor failure to be caused by faulty material or workmanship, repair will be under warranty when within the warranty period. Motor failure because of external causes will result in a charge to the owner for repair.

1. LOCK OUT THE MAIN POWER SUPPLY, then remove fan guard, venturi and blade as outlined earlier.
2. Open motor junction box cover and disconnect the motor lead wires from within the box.

NOTE: Tag or otherwise identify wires for ease of re-assembly.

3. Remove motor mount bolts. If there are any shims between the motor and its base, note their locations so they can be properly installed during re-assembly.
4. Disconnect the motor end of the motor conduit, if required, then carefully pull conduit and wires through hole in the motor junction box. Remove motor. If motor requires service, take it to an Authorized Service Station.
5. To re-install motor, slide onto motor base plate and replace shims (if required) between motor and base plate. Re-install motor mount bolts and washers and fully tighten them at this time. Re-install conduit and wires and carefully remake all electrical wiring connections.

NOTE: Make sure to install and tighten the blade in accordance with earlier instructions.

Vane Axial Fan Parts

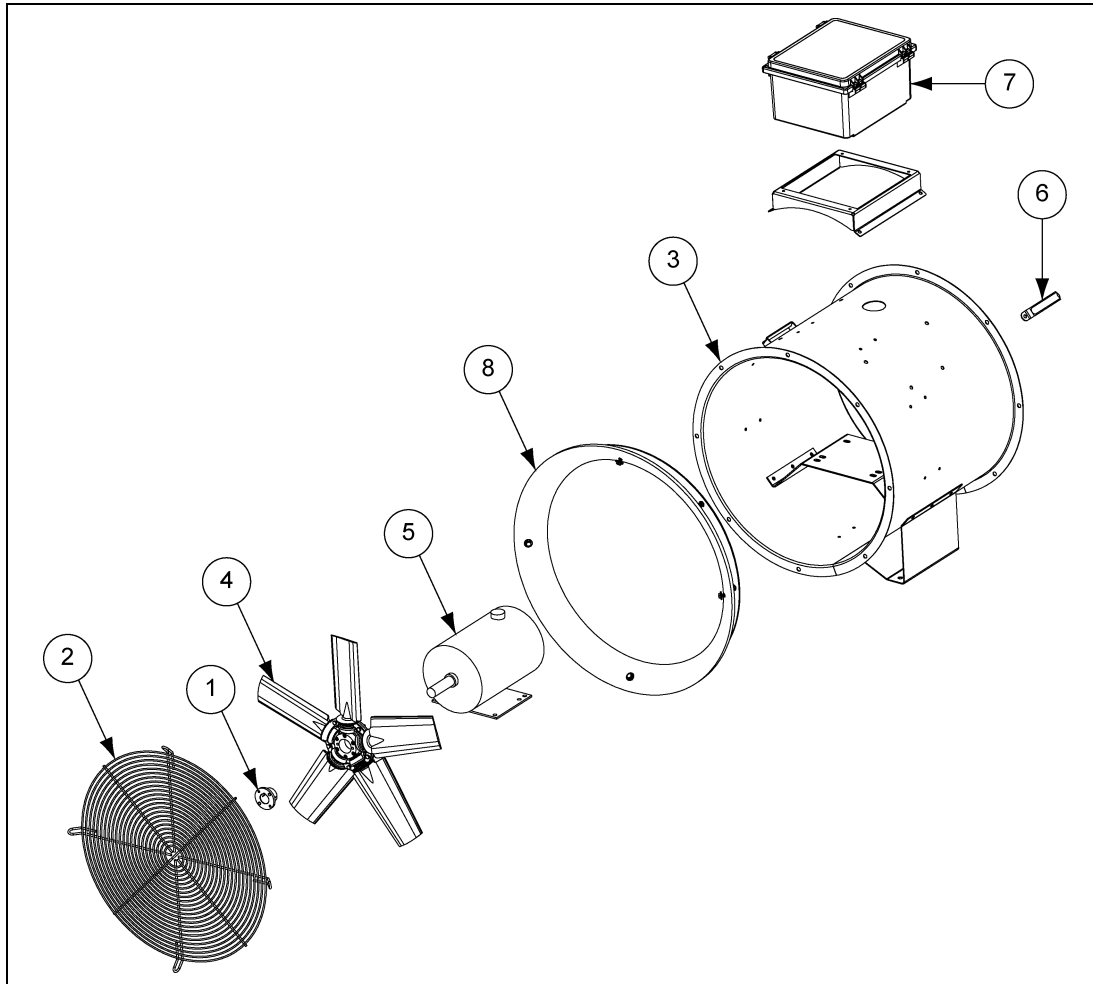

Vane Axial Fan Parts List

Ref #	Part #							Description
	AF-12-*G	AF-14-*G	AF-1.5-*G	AF-3-*G	AF-7-*G	AF-10-*G	AF-158-*G	
1	FH-5536	FH-5536	FH-5535	FH-3660	F-7199	F-7199	F-7199	Split Taper Bushing
2	F-7177	F-7178	F-7179	F-7179	014-1042-2-W	014-1042-2-W	014-1043-0-W	Grill Guard
3	F-7225	F-7230	F-7248	F-7248	F-7330	F-7330	F-7332	Fan Housing
4	F-7252	F-7301	F-7254	F-7255	F-6920	F-6921	F-6923	Blade Assembly
5	FH-6980	FH-6980	FH-5539	FH-6258	FH-6436	FH-6436	FH-6584	380V 3 PH Motor
5	N/A	N/A	N/A	F-7187	F-7397	F-7397	FH-5650-7	415V 3 PH Motor
6	PR-331	PR-331	PR-331	PR-331	PR-331	PR-331	PR-331	Handle
7	N/A	N/A	N/A	N/A	N/A	N/A	N/A	Junction Enclosure
7	N/A	N/A	N/A	N/A	N/A	N/A	N/A	Control Enclosure
8	N/A	N/A	N/A	N/A	F-7316	F-7316	F-7317	Venturi
Weight (kg)	23	25	35	45	80	102	89	

NOTES

GSI Group, LLC Limited Warranty

The GSI Group, LLC ("GSI") warrants products which it manufactures to be free of defects in materials and workmanship under normal usage and conditions for a period of 12 months after sale to the original end-user or if a foreign sale, 14 months from arrival at port of discharge, whichever is earlier. The end-user's sole remedy (and GSI's only obligation) is to repair or replace, at GSI's option and expense, products that in GSI's judgment, contain a material defect in materials or workmanship. Expenses incurred by or on behalf of the end-user without prior written authorization from the GSI Warranty Group shall be the sole responsibility of the end-user.

Warranty Extensions:

The Limited Warranty period is extended for the following products:

	Product	Warranty Period	
AP Fans and Flooring	Performer Series Direct Drive Fan Motor	3 Years	* Warranty prorated from list price: 0 to 3 years - no cost to end-user 3 to 5 years - end-user pays 25% 5 to 7 years - end-user pays 50% 7 to 10 years - end-user pays 75%
	All Fiberglass Housings	Lifetime	
	All Fiberglass Propellers	Lifetime	
Cumberland Feeding/Watering Systems	Feeder System Pan Assemblies	5 Years **	** Warranty prorated from list price: 0 to 3 years - no cost to end-user 3 to 5 years - end-user pays 50%
	Feed Tubes (1-3/4" and 2.00")	10 Years *	
	Centerless Augers	10 Years *	
	Watering Nipples	10 Years *	
Grain Systems	Grain Bin Structural Design	5 Years	
Grain Systems Farm Fans Zimmerman	Portable and Tower Dryers	2 Years	† Motors, burner components and moving parts not included. Portable dryer screens included. Tower dryer screens not included.
	Portable and Tower Dryer Frames and Internal Infrastructure †	5 Years	

GSI further warrants that the portable and tower dryer frame and basket, excluding all auger and auger drive components, shall be free from defects in materials for a period of time beginning on the twelfth (12th) month from the date of purchase and continuing until the sixtieth (60th) month from the date of purchase (extended warranty period). During the extended warranty period, GSI will replace the frame or basket components that prove to be defective under normal conditions of use without charge, excluding the labor, transportation, and/or shipping costs incurred in the performance of this extended warranty.

Conditions and Limitations:

THERE ARE NO WARRANTIES THAT EXTEND BEYOND THE LIMITED WARRANTY DESCRIPTION SET FORTH ABOVE. SPECIFICALLY, GSI MAKES NO FURTHER WARRANTY OF ANY KIND, EXPRESS OR IMPLIED, INCLUDING, WITHOUT LIMITATION, WARRANTIES OF MERCHANTABILITY OR FITNESS FOR A PARTICULAR PURPOSE OR USE IN CONNECTION WITH: (I) PRODUCT MANUFACTURED OR SOLD BY GSI OR (II) ANY ADVICE, INSTRUCTION, RECOMMENDATION OR SUGGESTION PROVIDED BY AN AGENT, REPRESENTATIVE OR EMPLOYEE OF GSI REGARDING OR RELATED TO THE CONFIGURATION, INSTALLATION, LAYOUT, SUITABILITY FOR A PARTICULAR PURPOSE, OR DESIGN OF SUCH PRODUCTS.

GSI shall not be liable for any direct, indirect, incidental or consequential damages, including, without limitation, loss of anticipated profits or benefits. The sole and exclusive remedy is set forth in the Limited Warranty, which shall not exceed the amount paid for the product purchased. This warranty is not transferable and applies only to the original end-user. GSI shall have no obligation or responsibility for any representations or warranties made by or on behalf of any dealer, agent or distributor.

GSI assumes no responsibility for claims resulting from construction defects or unauthorized modifications to products which it manufactured. Modifications to products not specifically delineated in the manual accompanying the equipment at initial sale will void the Limited Warranty.

This Limited Warranty shall not extend to products or parts which have been damaged by negligent use, misuse, alteration, accident or which have been improperly/inadequately maintained. This Limited Warranty extends solely to products manufactured by GSI.

Prior to installation, the end-user has the responsibility to comply with federal, state and local codes which apply to the location and installation of products manufactured or sold by GSI.

This equipment shall be installed in accordance with the current installation codes and applicable regulations, which should be carefully followed in all cases. Authorities having jurisdiction should be consulted before installations are made.

G S I G R O U P



GSI Group
1004 E. Illinois St.
Assumption, IL 62510-0020
Phone: 1-217-226-4421
Fax: 1-217-226-4420
www.gsiag.com