

Vane Axial Fan

MODEL # DF ___ - ___ - ___ - ___ (W/CONTROLS)

MODEL # AF ___ - ___ - ___ - ___ (LESS CONTROLS)

Owner's Manual

MANUAL # PNEG-010-C

THE GSI GROUP



FAN CHECK LIST

✓OK

- _____ 1. All wire connections
- _____ 2. Tip clearance on blade
- _____ 3. Fan blade torqued to torque specs
- _____ 4. Grill guard in place and tight
- _____ 5. Fuse in place, extra fuse provided
- _____ 6. Motor rotation correct
- _____ 7. Contactor engages properly
- _____ 8. Running amperage
- _____ 9. Vibration
- _____ 10. All fasteners tight
- _____ 11. Indicator light
- _____ 12. All decals and serial number tag
- _____ 13. Aesthetic appearance
- _____ 14. Manual

Tester Signature _____

Date _____

VANE AXIAL FAN OPERATING INSTRUCTIONS

TABLE OF CONTENTS

Warranty.....	4
Roof Warning, Operation & Safety.....	5
Safety Alert Decals.....	6
Installation Instructions.....	7
Fan Pad Location.....	7
Checklist Before Installing The Fan.....	8
Installation.....	8
Fan Specifications.....	9
Fan Installation.....	11
Machine To Earth Ground.....	11
Proper Installation Of The Ground Rod.....	11
Previously Installed Units.....	11
Fan Operation.....	12
Start-Up.....	12
Maintaining Grain Quality.....	12
Grain Storage.....	12
Equilibrium Moisture Chart.....	12
Approximate Allowable Holding Time For Field-Shelled Corn.....	12
Approximate Hours Of Fan Time To Change Bin Temperature.....	13
Fan Service.....	14
Lubrication.....	14
Hub Bolt Torque Requirement For Fan Blades.....	15
Fan Troubleshooting Chart.....	15
Fan Parts.....	16
12" Fan.....	16
14" Fan.....	17
18" Fan.....	18
18" 3 HP 1 Phase Control Box Parts.....	19
18" 3 HP 3 Phase Control Box Parts.....	20
24" Fan.....	21
24" 7 HP 1 Phase Control Box Parts.....	22
24" 7 HP 3 Phase Control Box Parts.....	23
24" 10 HP 1 Phase Control Box Parts.....	24
24" 10 HP 3 Phase Control Box Parts.....	25
26" Fan.....	26
28" Fan.....	27
26" & 28" 15 HP 1 Phase Control Box Parts.....	28
26" & 28" 15 HP 3 Phase Control Box Parts.....	29
240 Volt 1 Phase (3 HP).....	30
240 Volt 1 Phase (7 And 10 HP).....	31
240 Volt 1 Phase (15HP).....	32
240 Volt 3 Phase (All Horsepowers).....	33
480 Volt 3 Phase (All Horsepowers).....	34
575 Volt 3 Phase (All Horsepowers).....	35
Notes.....	36

THE GSI GROUP, INC. WARRANTY

THE GSI GROUP, INC. ("GSI") WARRANTS ALL PRODUCTS WHICH IT MANUFACTURES TO BE FREE OF DEFECTS IN MATERIAL AND WORKMANSHIP UNDER NORMAL USAGE AND CONDITIONS FOR A PERIOD OF 12 MONTHS AFTER RETAIL SALE TO THE ORIGINAL END USER. THE PURCHASER'S SOLE REMEDY AND GSI'S ONLY OBLIGATION SHALL BE TO REPAIR OR REPLACE, AT GSI'S OPTION AND EXPENSE, PRODUCTS THAT, IN GSI'S SOLE JUDGMENT, CONTAIN A MATERIAL DEFECT DUE TO MATERIALS OR WORKMANSHIP. ALL DELIVERY AND SHIPMENT CHARGES TO AND FROM GSI'S FACTORY WILL BE PURCHASER'S RESPONSIBILITY. EXPENSES INCURRED BY OR ON BEHALF OF THE PURCHASER WITHOUT PRIOR WRITTEN AUTHORIZATION FROM AN AUTHORIZED EMPLOYEE OF GSI SHALL BE THE SOLE RESPONSIBILITY OF THE PURCHASER.

EXCEPT FOR THE LIMITED WARRANTY EXPRESSED ABOVE, GSI MAKES NO FURTHER WARRANTY OF ANY KIND, EXPRESS OR IMPLIED, INCLUDING, WITHOUT LIMITATION, WARRANTIES OF MERCHANTABILITY OR FITNESS FOR A PARTICULAR PURPOSE OR USE IN CONNECTION WITH (I) PRODUCT MANUFACTURED OR SOLD BY GSI OR (II) ANY ADVICE, INSTRUCTION, RECOMMENDATION OR SUGGESTION PROVIDED BY AN AGENT, REPRESENTATIVE OR EMPLOYEE OF GSI REGARDING OR RELATED TO THE CONFIGURATION, INSTALLATION, LAYOUT, SUITABILITY FOR A PARTICULAR PURPOSE, OR DESIGN OF SUCH PRODUCTS.

GSI SHALL NOT BE LIABLE FOR ANY DIRECT, INDIRECT, INCIDENTAL OR CONSEQUENTIAL DAMAGES, INCLUDING, WITHOUT LIMITATION, LOSS OF ANTICIPATED PROFITS OR BENEFITS. PURCHASER'S SOLE AND EXCLUSIVE REMEDY IS AS SET FORTH IN THE LIMITED WARRANTY EXPRESSED ABOVE, WHICH SHALL NOT EXCEED THE AMOUNT PAID FOR THE PRODUCT PURCHASED. THIS WARRANTY IS NOT TRANSFERABLE AND APPLIES ONLY TO THE ORIGINAL PURCHASER. GSI SHALL HAVE NO OBLIGATION OR RESPONSIBILITY FOR ANY REPRESENTATIONS OR WARRANTIES MADE BY OR ON BEHALF OF ANY DEALER, AGENT OR DISTRIBUTOR OF GSI.

GSI ASSUMES NO RESPONSIBILITY FOR CLAIMS RESULTING FROM ERECTION DEFECTS OR UNAUTHORIZED MODIFICATIONS TO PRODUCTS WHICH IT MANUFACTURED. MODIFICATIONS TO PRODUCTS NOT SPECIFICALLY DELINEATED IN THE MANUAL ACCOMPANYING THE EQUIPMENT AT INITIAL SALE WILL NULLIFY THE PRODUCT WARRANTY THAT MIGHT HAVE BEEN OTHERWISE AVAILABLE.

THE FOREGOING WARRANTY SHALL NOT EXTEND TO PRODUCTS OR PARTS WHICH HAVE BEEN DAMAGED BY NEGLIGENT USE, MISUSE, ALTERATION OR ACCIDENT. THIS WARRANTY EXTENDS SOLELY TO ONLY PRODUCTS MANUFACTURED BY GSI. THIS WARRANTY IS EXCLUSIVE AND IN LIEU OF ALL OTHER WARRANTIES EXPRESS OR IMPLIED. GSI RESERVES THE RIGHT TO MAKE DESIGN OR SPECIFICATION CHANGES AT ANY TIME.

PRIOR TO INSTALLATION, PURCHASER HAS THE RESPONSIBILITY TO COMPLY WITH ALL FEDERAL, STATE AND LOCAL CODES WHICH MAY APPLY TO THE LOCATION AND INSTALLATION OF PRODUCTS MANUFACTURED OR SOLD BY GSI.

ROOF WARNING, OPERATION & SAFETY

ROOF DAMAGE WARNING AND DISCLAIMER

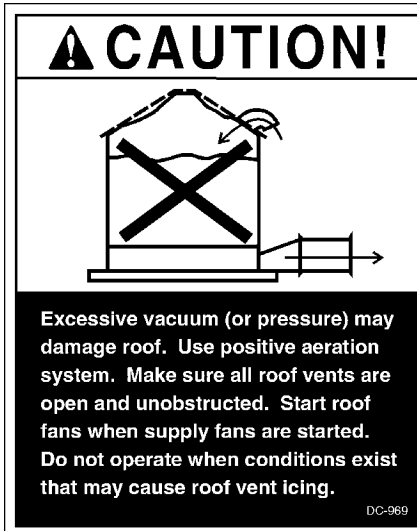

GSI DOES NOT WARRANT ANY ROOF DAMAGE CAUSED BY EXCESSIVE VACUUM OR INTERNAL PRESSURE FROM FANS OR OTHER AIR MOVING SYSTEMS. ADEQUATE VENTILATION AND/OR "MAKEUP AIR" DEVICES SHOULD BE PROVIDED FOR ALL POWERED AIR HANDLING SYSTEMS. GSI DOES NOT RECOMMEND THE USE OF DOWNWARD FLOW SYSTEMS (SUCTION). SEVERE ROOF DAMAGE CAN RESULT FROM ANY BLOCKAGE OF AIR PASSAGES. RUNNING FANS DURING HIGH HUMIDITY/COLD WEATHER CONDITIONS CAN CAUSE AIR EXHAUST OR INTAKE PORTS TO FREEZE.

FAN OPERATION

Thank you for choosing a GSI/Airstream product. It is designed to give excellent performance and service for many years.

This manual describes the operation of the Airstream Vane Axial Fan. It is designed for medium to high static pressures, and comes equipped with a 3450 RPM motor.

The principal concern of the GSI Group, Inc. ("GSI") is your safety and the safety of others associated with grain handling equipment. This manual is written to help you understand safe operating procedures, and some of the problems that may be encountered by the operator or other personnel.

As owner and/or operator, it is

your responsibility to know what requirements, hazards and precautions exist, and to inform all personnel associated with the equipment, or who are in the area. Avoid any alterations to the equipment. Such alterations may produce a very dangerous situation, where serious injury or death may occur.

SAFETY ALERT SYMBOL

The symbol shown is used to call your attention to instructions concerning your personal safety. Watch for this symbol; it points out important safety precautions. It means "ATTENTION", "WARNING", "CAUTION", and "DANGER". Read the message and be cautious to the possibility of personal injury or death.



WARNING! BE ALERT!

Personnel operating or working around electric fans should read this manual. This manual must be delivered with the equipment to its owner. Failure to read this manual and its safety instructions is a misuse of the equipment.

SAFETY ALERT DECALS

Grain Systems, Inc. recommends contacting your local power company, and having a representative survey your installation so the wiring is compatible with their system, and adequate power is supplied to your unit.

Safety decals should be read and understood by all people in the grain handling area. The bottom right decal should be present on the inside bin door cover of the two ring door, 24" porthole door cover and the roof manway cover.

If a decal is damaged or is missing contact:

Grain Systems, Inc.
1004 E. Illinois St.
Assumption, IL 62510
217-226-4421

A free replacement will be sent to you.



! WARNING

Stay clear of rotating blade. Blade could start automatically. Can cause serious injury. Disconnect power before servicing.

DC-1225





! DANGER!

High voltage. Will cause injury or death. Lockout power before servicing.

DC-889

! DANGER

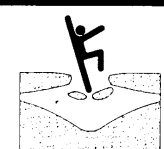
 <p style="font-size: x-small;">Rotating flighting can kill or dismember.</p>	 <p style="font-size: x-small;">Flowing material can trap and suffocate.</p>	 <p style="font-size: x-small;">Crusted material can collapse and suffocate.</p>
--	---	--

Keep clear of all augers.
DO NOT ENTER this bin!

If you must enter this bin:

1. Shut off and lock out all power.
2. Use safety harness and safety line.
3. Station another person outside the bin.
4. Avoid the center of the bin.
5. Wear proper breathing equipment or respirator.

Failure to heed these warnings will result in serious injury or death.

DC-552

INSTALLATION INSTRUCTIONS

FAN PAD LOCATION

FOR USE WITH TR-6918 & TR-6919 OVAL TRANSITION

Fan pad should be poured level with top of bin foundation for all vane axial fans 18" through 26" diameter.

The pad for Airstream heaters is not required. If a vane axial heater may be installed at a later date, then it would be recommended to pour fan pad 26" wide and 52" long. Fan should be centered on center line of bin.

IMPORTANT! FAN PAD AND FAN MUST BE LEVEL AND SMOOTH FOR PROPER OPERATION. VIBRATION PROBLEMS CAN RESULT FROM IMPROPER FAN LEVELING.

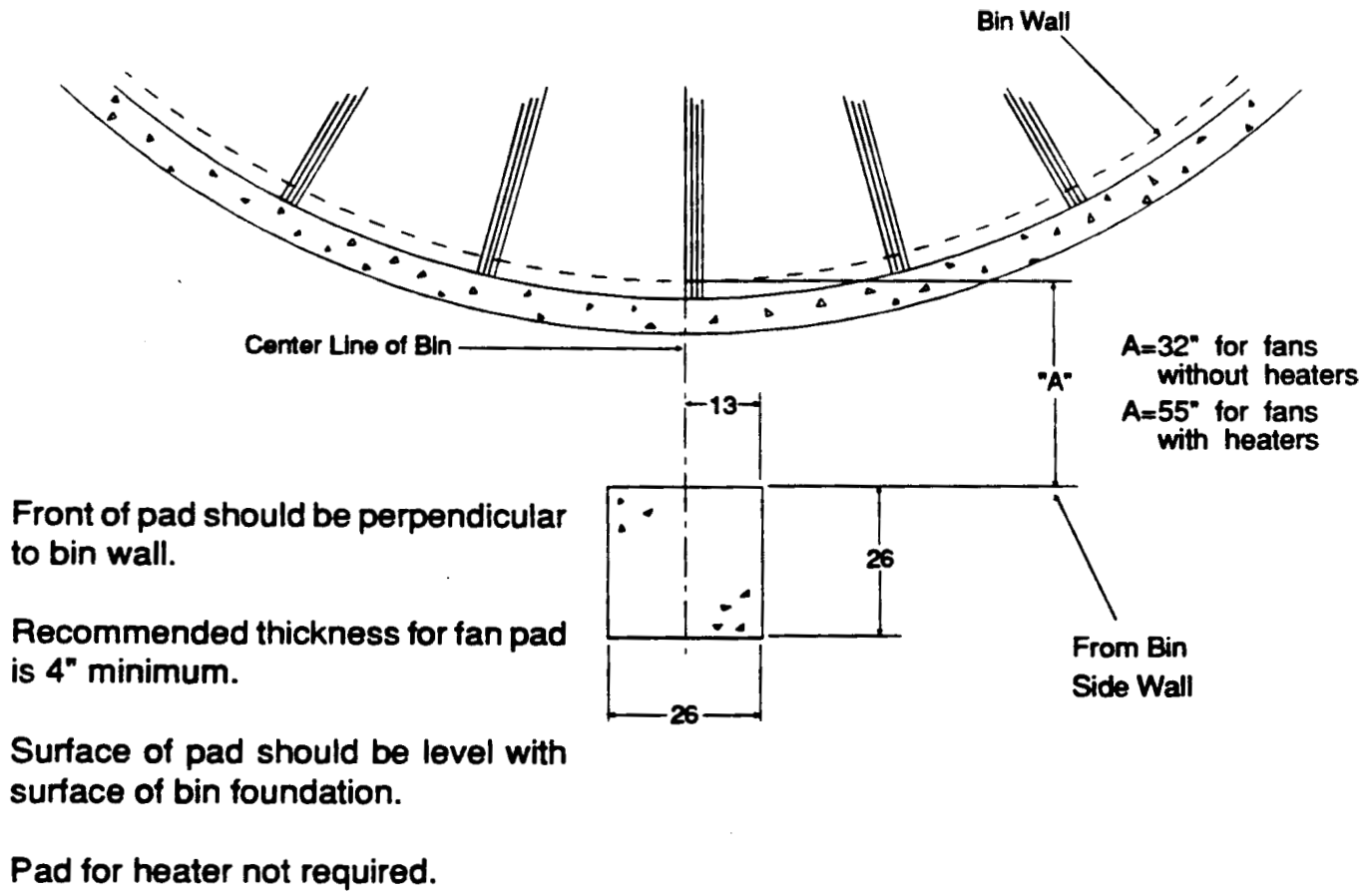

Figure 1: Fan pad installation guidelines.

INSTALLATION INSTRUCTIONS

CHECKLIST BEFORE INSTALLING THE FAN

1. One of the most important factors for installation is providing adequate power to run the unit. Undersized wire can lead to voltage drop and can cause motor overheating and shortened life. Therefore, it is necessary to know the distance from the unit to available transformer and the horsepower of your fan unit. These two factors will determine the size of wire needed for efficient operation. See Fan



**ALWAYS DISCONNECT
AND LOCK OUT POWER
BEFORE WORKING ON OR
AROUND HEATER**

Specifications on the following page.

2. Grain Systems, Inc. recommends contacting your local power company, and having a representative survey your installation so the wiring is compatible with their system, and adequate power is supplied to your unit.
3. Each fan motor should be wired through a fused or circuit breaker disconnect switch.
4. Refer to Fan Specifications on page 9 for the recommended slow blow fuse or breaker size to use when installing your particular fan.
5. Standard electrical safety practices and codes should be used. (Refer to National Electrical Code Standard Handbook by National Fire Protection Association).
6. A qualified electrician should make all electrical wiring installations.

INSTALLATION

1. Be sure that the disconnect and the fan are well grounded. See machine to earth ground on page 11.
2. Rotate the fan blade to be sure that it revolves easily and does not rub the housing.
3. Check all fasteners on motor mounts, fan blades and other bolted items to make sure they are tight. If any are loose, check for proper clearance and retighten fasteners. They may have loosened in shipping.
4. Fans should be mounted to set level and solid. It may be necessary to shim one or more corners of the foot mount to achieve a solid mounting. Fans not solidly mounted and properly shimmed may have excess vibration in them.
5. Check and retighten all electrical connections. They may have loosened in shipping.

FAN SPECIFICATIONS

FAN HORSEPOWER	3/4				1				1.1/2				3			
RPM	3450				3450				3450				3450			
PHASE	1	3			1	3			1	3			1	3		
VOLTS	230	230	460	575	230	230	460	575	230	230	460	575	230	230	460	575
FULL LOAD AMPS	5.5	2.6	1.3	1.0	5.5	3.0	1.5	1.2	7.5	4.6	2.3	1.8	15	7.4	3.7	3
MINIMUM WIRE SIZE	Copper Wire				Copper Wire				Copper Wire				Copper Wire			
50' RUN	14	14	14	14	14	14	14	14	14	14	14	14	12	12	14	14
100' RUN	14	14	14	14	14	14	14	14	12	14	14	14	10	12	12	12
200' RUN	12	14	14	14	12	14	14	14	8	12	14	14	8	10	12	12
300' RUN	10	14	14	14	10	14	14	14	6	10	12	12	6	8	10	10
MINIMUM WIRE SIZE	Aluminum Wire				Aluminum Wire				Aluminum Wire				Aluminum Wire			
50' RUN	14	14	14	14	14	14	14	14	12	12	14	14	12	12	12	12
100' RUN	14	14	14	14	14	14	14	14	10	12	12	14	8	10	12	12
200' RUN	10	14	14	14	10	14	14	14	6	10	12	12	6	10	10	10
300' RUN	8	12	14	14	8	12	14	14	4	10	12	12	4	8	10	10
FUSE SIZE (SLOW BLOW)	15	10	5	5	15	10	5	5	15	10	5	5	30	15	10	10
BREAKER SIZE	20	15	10	10	20	15	10	10	20	15	10	10	40	20	15	15

FAN HORSEPOWER	7				10				15			
RPM	3450				3450				3450			
PHASE	1	3			1	3			1	3		
VOLTS	230	230	460	575	230	230	460	575	230	230	460	575
FULL LOAD AMPS	30	18	9	6.9	47	25	13	9.6	57	32	16	14
MINIMUM WIRE SIZE	Copper Wire				Copper Wire				Copper Wire			
50' RUN	10	12	12	12	10	10	12	12	8	8	12	12
100' RUN	8	10	12	12	6	8	10	12	6	6	10	12
200' RUN	4	8	10	12	4	6	10	10	2	4	10	10
300' RUN	4	6	8	10	2	4	8	8	0	4	8	10
MINIMUM WIRE SIZE	Aluminum Wire				Aluminum Wire				Aluminum Wire			
50' RUN	8	10	12	12	8	10	12	12	6	8	10	10
100' RUN	6	8	10	12	4	8	10	10	4	6	8	10
200' RUN	3	6	10	10	2	4	8	10	0	4	6	8
300' RUN	2	4	8	10	0	2	6	8	00	2	4	6
FUSE SIZE (SLOW BLOW)	40	25	15	15	60	30	20	15	75	40	20	20
BREAKER SIZE	60	30	15	15	80	40	20	20	100	60	30	20

FAN SPECIFICATIONS

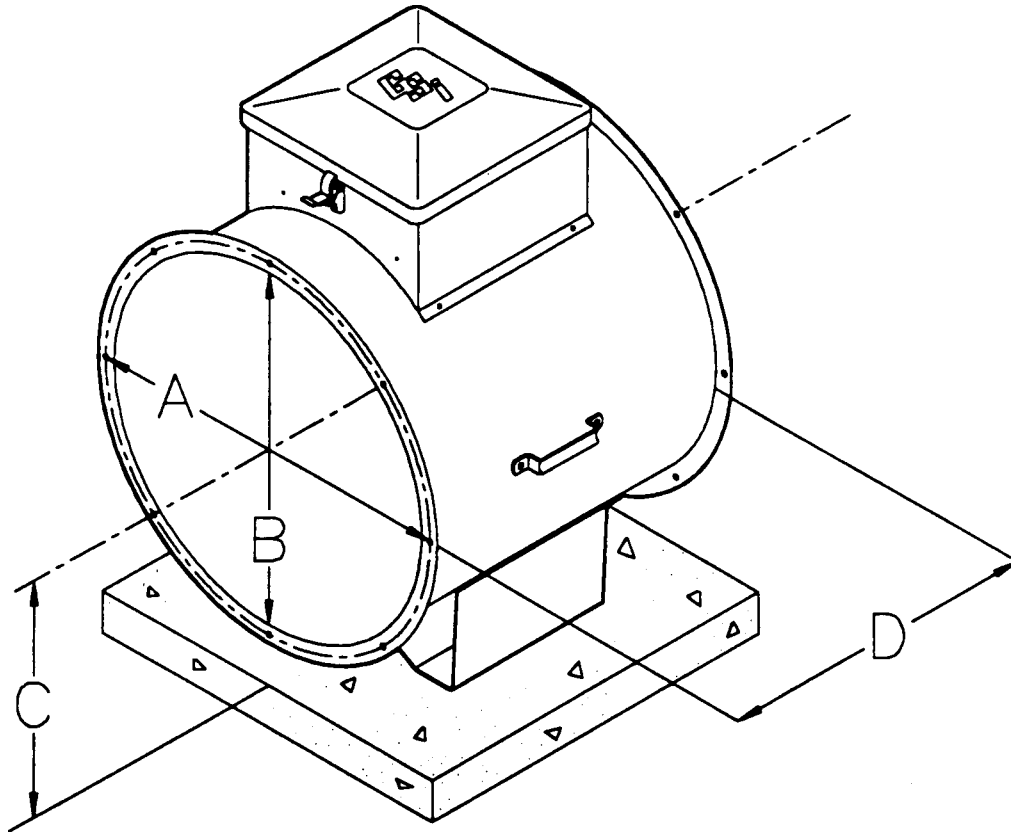

Figure 2: Fan dimensions

FAN	12" Dia	14" Dia	18" Dia	24" Dia	26" Dia	28" Dia
A (BOLT CIRCLE)	12.3/4	15.1/8	19.1/2	25.3/4	27.11/16	29.5/8
B (INSIDE DIA)	11.7/8	14.1/8	18.1/4	24.1/4	26.5/16	28.1/8
C (CL TO BOTTOM OF LEG)	8	10	13.5/16	15.3/8	16.7/8	18.1/8
D (LENGTH)	14.1/8	14.1/8	22	23.1/2	20.1/4	26

Note: All Dimensions in inches.

FAN INSTALLATION



Dig a hole large enough to hold 1 or 2 gallons of water. Work the ground rod into the earth until it is completely in the ground.

MACHINE TO EARTH GROUND

It is very important that a machine to earth ground rod be installed at the fan. This is true even if there is a ground at the pole 15 feet away. This ground needs to be as close to the fan as possible, but no more than 8 feet away. The ground rod should be connected to the fan control panel with at least a #6 solid bare copper ground wire, or in accordance with local requirements. The machine to earth ground provides additional safety if there is a short. It also provides the grounding necessary for long life and operation of the solid state circuit boards used on control circuits and the electronic ignition systems.

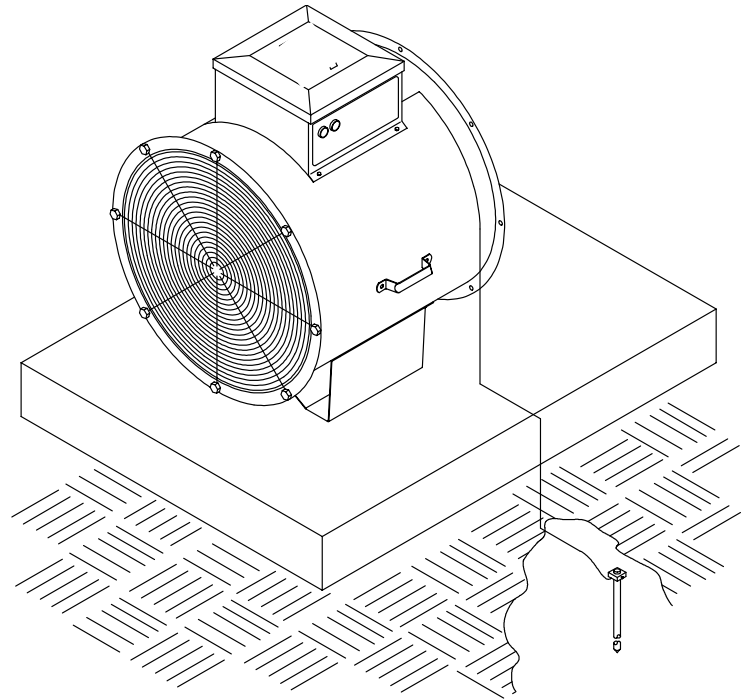

Figure 3: Use a #6 or approved size bare copper ground wire. Install a 5/8" diameter 8' long copper-clad ground rod, 2' away from the foundation and 1' below the surface of the ground or in accordance with local requirements.

PROPER INSTALLATION OF THE GROUND ROD

(Ground rods and wires are not supplied by Airstream). It is recommended that the rod not be driven into dry ground. The following steps ensure proper ground rod installation:

1. Dig a hole large enough to hold 1 to 2 gallons of water.
2. Fill hole with water.
3. Insert rod through water and jab it into the ground.
4. Continue jabbing the rod up and down, the water will work its way down the hole, making it possible to work the rod completely into the ground. This method of installing the rod gives a good

conductive bond with the surrounding soil.

5. Connect the bare copper ground wire to the rod with the proper ground rod clamp.
6. Connect the bare ground wire to the fan control boxes with a grounding lug. See Figure 3.
7. Ground wire must not have any breaks or splices. Insulated wire is not recommended for grounding.

PREVIOUSLY INSTALLED UNITS

It is recommended that previously installed units be checked to see that a machine to earth ground has been installed by an electrician.

FAN OPERATION

START-UP

On initial start-up of the fan, run it momentarily to make sure that the fan blade is rotating in the proper direction and airflow is correct. If not, change motor direction using instructions on the motor.

Proper installation and start-up ensures many years of trouble-free operation.

MAINTAINING GRAIN QUALITY

To properly maintain the quality of stored grain, it is necessary to keep the grain dry, cool and insect free. Any one of these problems can contribute to spoilage. Wet, warm grain promotes insect growth as well as

grain spoilage. Cool, dry grain can keep for long periods of time.

It is recommended that the grain be kept cool (avoid freezing as freezing can reduce quality). Grain should be cooled through the fall and winter, warmed in the spring and summer.

GRAIN STORAGE

Average grain temperature should be above 35°F in the winter and below 65°F in the summer. Always try to keep the grain within 10-15°F of the average monthly outside temperature. This means grain may need to be aerated on warm days during the winter to stay above 35°F when freezing temperatures are pre-

dominate. During the summer it may be necessary to aerate the grain on cool nights, so the 65°F temperature is not exceeded during the hot days of summer.

Conditions and requirements may vary from area to area. We suggest that you contact your local Agriculture Extension Office or State Ag. University for more exact guidelines.

If the grain is to be stored more than one year, it has to be re-cooled the following fall and winter, repeating the process as long as the grain is in storage. **Frequent and regular inspection (at least weekly during fall and spring) is the best prevention against grain spoilage).**

EQUILIBRIUM MOISTURE CHART

Air Temperature	Percentage Relative Humidity													
	35	40	45	50	55	60	65	70	75	80	85	90	95	100
20°F	11.2	11.7	12.7	13.7	14.5	15.1	16.2	17.1	18.0	19.6	21.2	23.5	25.8	29.1
30°F	10.8	11.3	12.2	13.1	13.9	14.6	15.5	16.4	17.4	18.7	20.2	22.5	25.0	28.3
40°F	10.5	11.0	11.7	12.5	13.3	14.0	14.8	15.5	16.6	17.8	19.4	21.5	24.2	27.5
50°F	10.1	10.6	11.3	12.0	12.7	13.3	14.1	14.8	15.8	16.9	18.6	20.5	23.4	26.7
60°F	9.7	10.2	10.9	11.6	12.1	12.7	13.4	14.2	15.0	16.0	17.8	19.5	22.6	25.9
70°F	9.0	9.7	10.4	11.1	11.5	12.0	12.8	13.5	14.5	15.4	16.8	18.5	21.3	24.5
80°F	8.3	9.1	9.8	10.5	10.8	11.2	12.1	13.0	13.9	14.8	15.8	17.4	20.0	22.8

Safe moisture for normal winter storage of shelled corn is about 15%. Grain to be stored through the summer or long term, needs to be 1 to 3 points dryer.

APPROXIMATE ALLOWABLE HOLDING TIME FOR FIELD-SHELLED CORN, TO MAINTAIN GRADE*

Grain (°F)	15%	18%	20%	22%	24%	26%	28%	30%
Temperature	days	days	days	days	days	days	days	days
40°F	898	195	85	54	38	28	24	20
50°F	451	102	46	28	19	16	13	11
60°F	242	63	26	16	10	8	6.5	5.5
70°F	147	37	13	8	5	4	3.5	3
80°F	109	27	10	6	4	3	2.5	2

*Allowable holding time for field-shelled corn at various grain temperatures and moisture

FAN OPERATION

Drying fronts and/or temperature fronts move through grain at different rates depending on bin and fan size and different moistures and temperatures.

The table below lists the ap-

proximate time required to completely change the temperature of a bin. Current conditions can cause this time to vary greatly. Therefore, this should only be used as a guide.

It may be necessary to run the fan only part of a day because of changing weather conditions. It would be necessary to run it a few hours each day on several days to complete the temperature change.

APPROXIMATE HOURS OF FAN TIME TO CHANGE BIN TEMPERATURE

Fan Size H. P.	Bin dia. approx. 22 ft. to eave-approx. hours of fan time required									Approx. 32 ft. to eave		
	18	21	24	27	30	33	36	42	48	36	42	48
1	73	79	90	NR	NR	NR	NR	NR	NR	NR	NR	NR
1.5	56	61	65	66	76	82	92	NR	NR	NR	NR	NR
3	44	51	52	57	63	69	78	93	NR	NR	NR	NR
7	38	42	44	47	52	56	61	71	81	79	93	NR
10	35	37	41	42	45	49	53	62	71	72	82	92
15	30	32	35	39	40	42	45	54	63	62	70	80
App. BU	4,500	6,500	8,500	11,000	13,500	16,500	19,500	27,000	35,500	28,000	38,500	50,500

•Bushels are rounded and approximate.

•The hours required are based on clean grain. High moisture grain and grain containing fines or foreign material will require more time to complete the air change.

NR

•Not Recommended: Bins in the NR range, may require fan(s) of a different size to get the cool time into the accepted range.

•Bins requiring more than 100 hours of aeration to totally change the temperature may require continuous aeration at about 1/10th cfm per bushel or some other acceptable method.

FAN SERVICE

Motors used in Airstream fan units are all standard NEMA frame motors and are specially designed for use in crop drying applications. Most of the replacement parts for these motors are handled by authorized service stations of the various motor manufacturers.

1. Always disconnect and lock out power before working on or around fan motor and electrical components.
2. Malfunctioning electrical com-

ponents should be checked by a qualified electrician.

3. For extra motor life, any electric motor should be run for 30 minutes, once a month. This will help eliminate any damaging moisture build-up in the motor and bearings.
4. If excess vibration shows up at some point when the fan has been running smoothly, check the blade for these conditions:

- a. Fans setting idle in the summer offer an excellent place for mud dobbers to build their nests. A mud dobber nest on the back of the fan blade will cause the fan to be out of balance and vibrate.
- b. Also, mice have been known to nest in the back of a blade. When the fan is started the centrifugal force kills the mice, but throws the blade out of balance.

LUBRICATION

This is a ball bearing motor. The bearings have been given initial lubrication at the factory. Motors without regreasing capability are factory lubricated for normal bearing life.

RELUBRICATION INTERVALS (MOTORS WITH REGREASING CAPABILITY)

New motors having been in storage for over a year should be relubricated by the procedure noted in the chart to ensure long operating life.

LUBRICANT

Baldor motors are pre-greased normally with Shell Oil Company's "Dolium R". Several equivalent greases which are compatible with the Baldor furnished grease are Chevron Oil's "SRI No. 2" and Texaco Inc.'s "Premium RB".

PROCEDURE

Overgreasing bearings can cause premature bearing failure. If motor

is equipped with Alemite fitting, clean tip of fitting and apply grease gun. Use 1 to 2 full strokes on motors in NEMA 215 frame and smaller. Use 2 to 3 strokes on NEMA 254 thru NEMA 365 frame. Use 3 to 4 strokes on NEMA 404 frames and larger. On motors having drain plugs, remove grease drain plug and operate motor for 20 minutes before replacing drain plug.

On motors equipped with slotted head grease screw, remove screw

and apply grease tube to hole. Insert 2 to 3 inch length of grease string into each hole on motors in NEMA 215 frame and smaller. Insert 3 to 5 inch length on larger motors. Motors having grease drain plugs, remove plug and operate motor for 20 minutes before replacing drain plug. **Keep grease clean. Lubricate motors at standstill. Remove and replace drain plugs at standstill. Do not mix petroleum grease and silicone grease in motor bearings.**

Hours of Service Per Year	Suggested Relube Interval		
	NEMAFRAME SIZE		
	42 to 215T	254 to 326T	364 to 447T
5000 Hrs.	5 years	3 years	1 years
Continuous Normal Application	2 years	1 years	9 months
Seasonal Service Motor is idle for 6 months or more	1 year (beginning of season)	1 year (beginning of season)	1 year (beginning of season)
Continuous high ambients, dirty or moist locations, high vibration or where shaft end is hot (pumps-fans)	6 months	6 months	3 months

FAN SERVICE

HUB BOLT TORQUE REQUIREMENT FOR FAN BLADES

- A. 12"-3/4HP through 14" 1HP.....50ft. lbs. (Trantorque)
- B. 18"-1.5HP through 18" 3HP.....63ft. lbs. (Trantorque)
- C. 24"-7HP through 28" 15HP.....84ft. lbs. (Trantorque)
- D. 24"-7HP through 28" 15HP.....16ft. lbs. (Browning)

FAN TROUBLESHOOTING CHART

SYMPTOM	POSSIBLE CAUSE	SOLUTION
Fan will not run	Blown fuse or breaker in disconnect switch Main power not turned on Defective wiring or loose connection Incorrect wire size Overload kicked out Defective motor Defective magnetic contactor	Replace fuses or reset breakers Turn power on at all disconnects ahead of the unit Follow wiring diagram and tighten any loose connections See wire size charts for proper wire size and change if needed Check manual reset, push in to reset Replace motor Check the magnetic contactor
Fan runs for a short period of time then shuts off	Undersize wiring Low line voltage at the installation. Power failure. Magnetic contactor malfunctioning. Defective start/stop button Wrong heater strip	Check to see that power supply wires are the proper size, contact your local power company. Call power company after making sure wire size is correct Change magnetic contactor Replace necessary part Replace with proper heater strip
Fan makes ticking noise	Fan blade hitting fan housing Motor bearing bad	Stop fan and turn off electricity. Remove fan screen and check to see if fan blade is hitting the housing. Adjust motor position to obtain proper clearance. Replace motor bearing
Fan vibrates	Fan not mounted securely to pad. Fan not level Fan has dirt deposit on blade Motor shaft is bent Blade not mounted properly on shaft Blade out of balance	Mount fan securely Level fan Clean blade Replace motor Mount blade properly on shaft Replace or have blade rebalanced

FAN PARTS

12" FAN

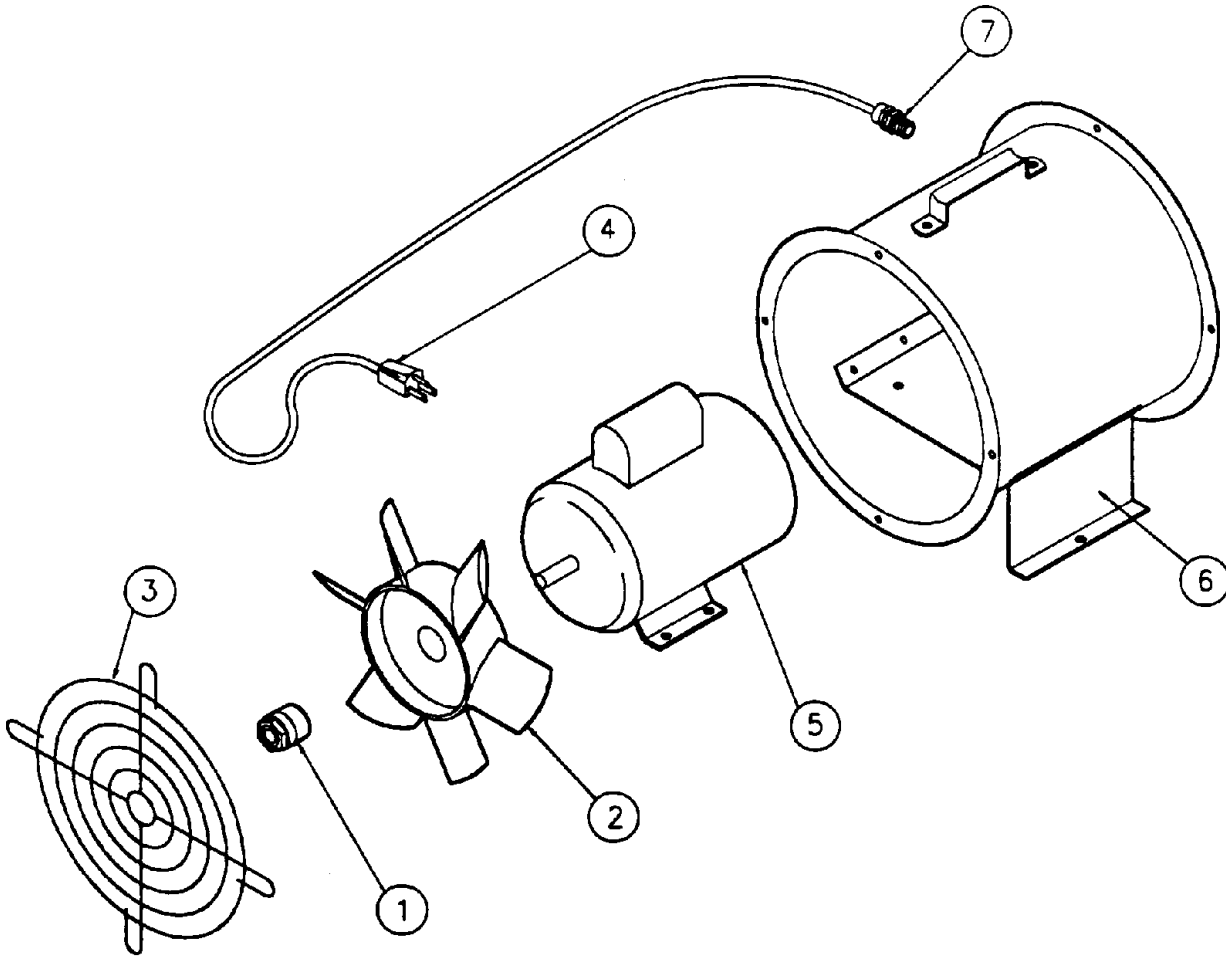

Key	Part Number	Description
1	FH-7018	Trantorque Bushing 5/8" Bore
2	F-6904	12" 1 HP Blade and Hub Assembly
2	FH-5719	12" 3/4 HP Blade and Hub Assembly
3	FH-1305	12" Grill Guard
4	HH-5159	1 PH Cord W/Plug
4	WR-14-4SJ	3 PH 14-4 SJ Cord (4Ft)
5	FH-1303	1 HP 1 PH Aeration Fan Motor
5	FH-1304	1 HP 3 PH Aeration Fan Motor
5	FH-5579	3/4 HP 1 PH Aeration Fan Motor
6	F-5755	12" Fan Housing Assembly
7	FH-1310	Cord Connector

FAN PARTS

14" FAN

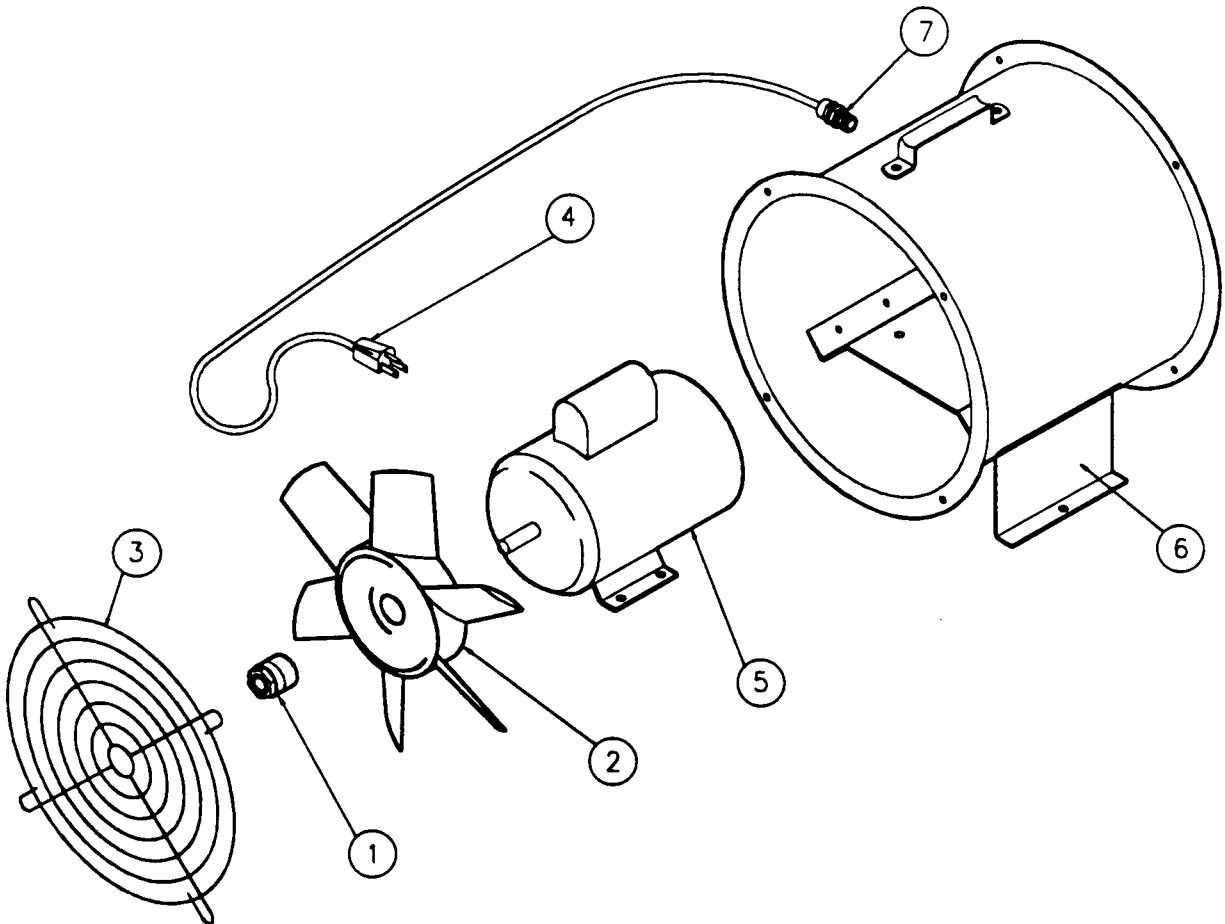

Key	Part Number	Description
1	FH-7018	Trantorque Bushing 5/8" Bore
2	F-6905	14" 1 HP Blade and Hub Assembly
3	FH-5726	14" Grill Guard
4	HH-5159	1 PH Cord W/Plug
4	WR-14-4SJ	3 PH 14-4 SJ Cord (4Ft)
5	FH-1303	1 HP 1PH Aeration Fan Motor
5	FH-1304	1 HP 3PH Aeration Fan Motor
6	F-5721	14" Fan Housing Assembly
7	FH-1310	Cord Connector

FAN PARTS

18" FAN

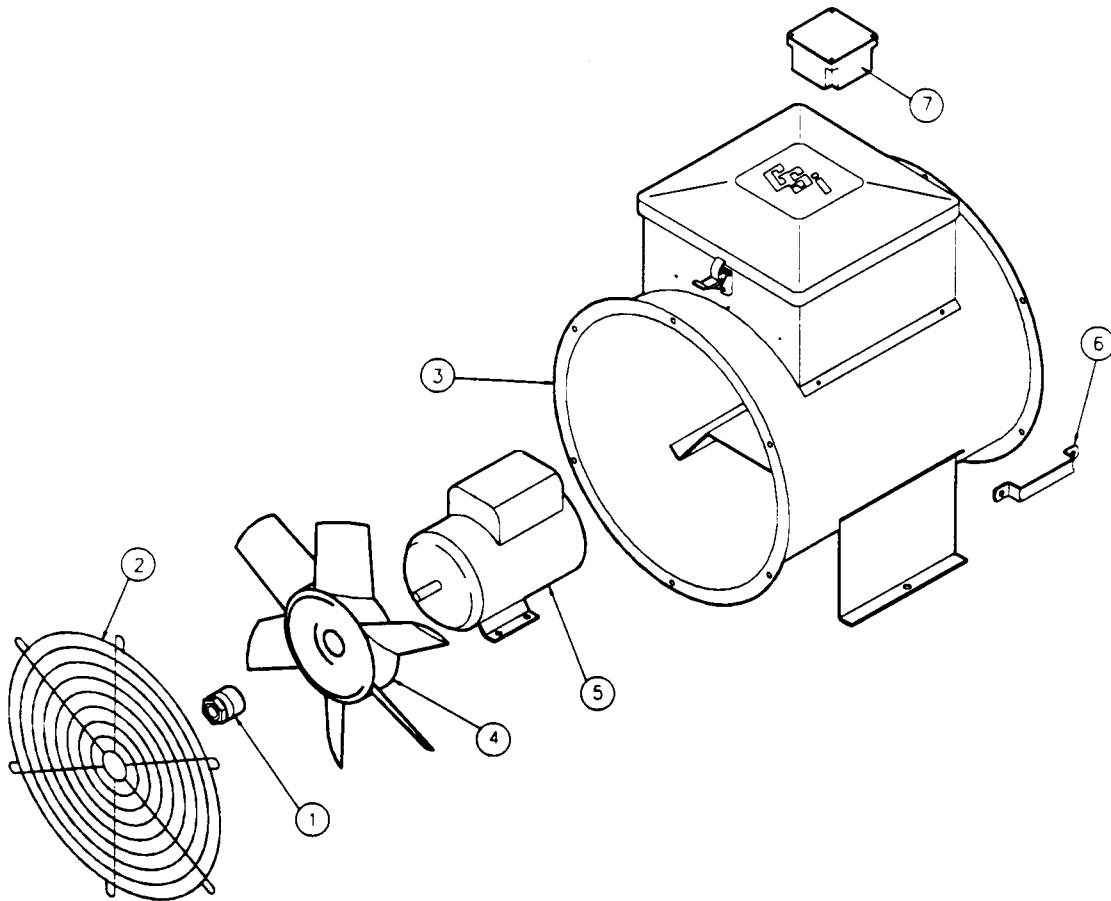

Key	Part Number	Description
1	FH-7019	Trantorque Bushing 7/8" Bore
1	FH-7020	Trantorque Bushing 1.1/8" Bore
2	F-953	18" Grill Guard
3	F-6700	18" Fan Wrapper
3	F-6698	18" Straightening Vane
3	F-6808	18" Base Leg
3	F-6701	18" Motor Mount
3	F-1131	18" Base Leg Strap
4	F-6906	1.5 HP 18" Blade and Hub Assembly
4	F-6907	3 HP 18" Blade and Hub Assembly
5	FH-5539	1.5 HP 1 PH Aeration Motor
5	FH-5540	1.5 HP 3 PH Aeration Motor
5	FH-5537	3 HP 1 PH Aeration Fan Motor
5	FH-5538	3 HP 3 PH Aeration Fan Motor
6	PR-331	Handle
7	*FH-6972	PVC Electric Box Assembly

*Aeration Fan Models Only

FAN PARTS

18" 3 HP 1 PHASE CONTROL BOX PARTS

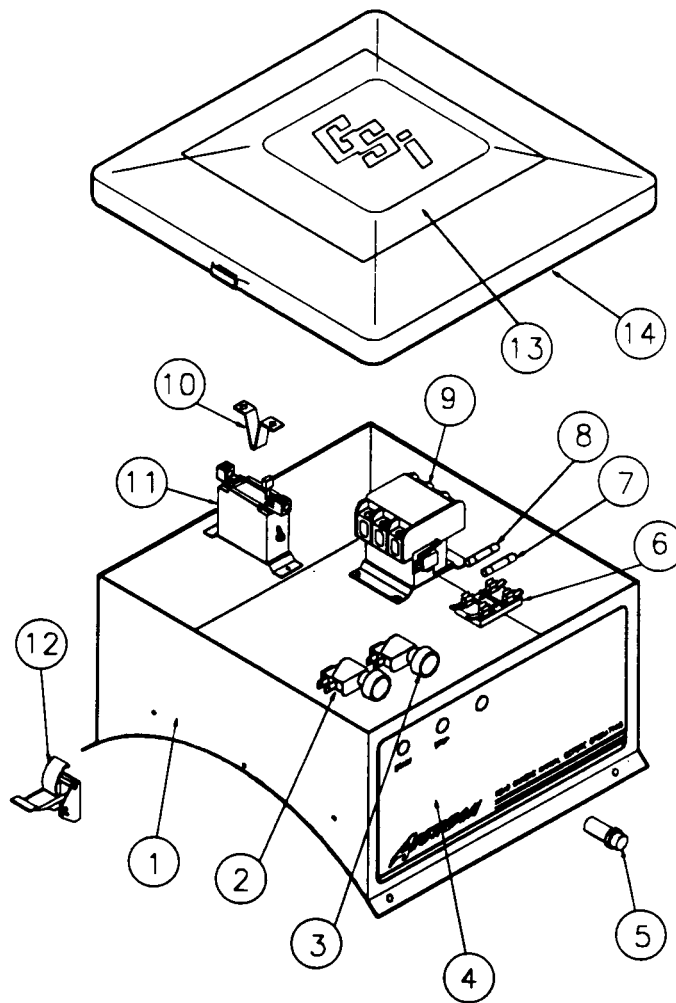

Key	Part Number	Description
1	F-6886	18" Control Box housing
2	FH-999	Start Switch
3	FH-1000	Stop Switch
4	DC-484	Control Box Decal
5	07097476	Red Light (230V)
6	FH-1058	Fuse Holder
7	FH-1059	5 Amp Fuse
8	00147938	1/4 Amp Fuse
9	CH-1039	30 Amp Contactor
10	FH-1003	Overload Relay
11	FH-5442	C198B GE Heater Strip
12	FH-4429-1	Spring Latch
13	DC-168	Wiring Decal
14	F-942	Control Box Lid

FAN PARTS

18" 3 HP 3 PHASE CONTROL BOX PARTS

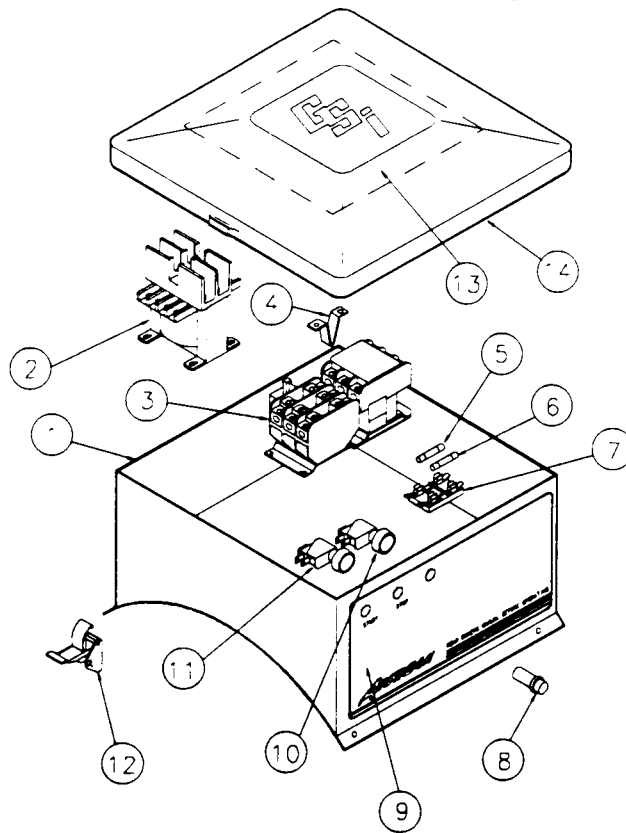

Key	Part Number	Description
1	F-6886	18" Control Box Housing
2	FH-6968	575V-110V Transformer (575V Only)
3	CH-1151	30 Amp Starter
4	FH-5735	C104B Heat Strip (230V Only)
4	FH-5736	C526A Heat Strip (460V Only)
4	FH-6969	C419A Heat Strip (575V Only)
5	00147938	1/4 Amp Fuse
6	FH-1059	5 Amp Fuse
7	FH-1058	Fuse Holder
8	07097476	Red Light (230V)
8	TFH-2021	Red Light (110V)
9	DC-484	Control Box Decal
10	FH-1000	Stop Switch
11	FH-999	Start Switch
12	FH-4429-1	Spring Latch
13	DC-171	230V 3 Phase Wiring Decal
13	DC-470	575V Wiring Decal
13	DC-351	460V Wiring Decal
14	F-942	Control Box Lid

FAN PARTS

24" FAN

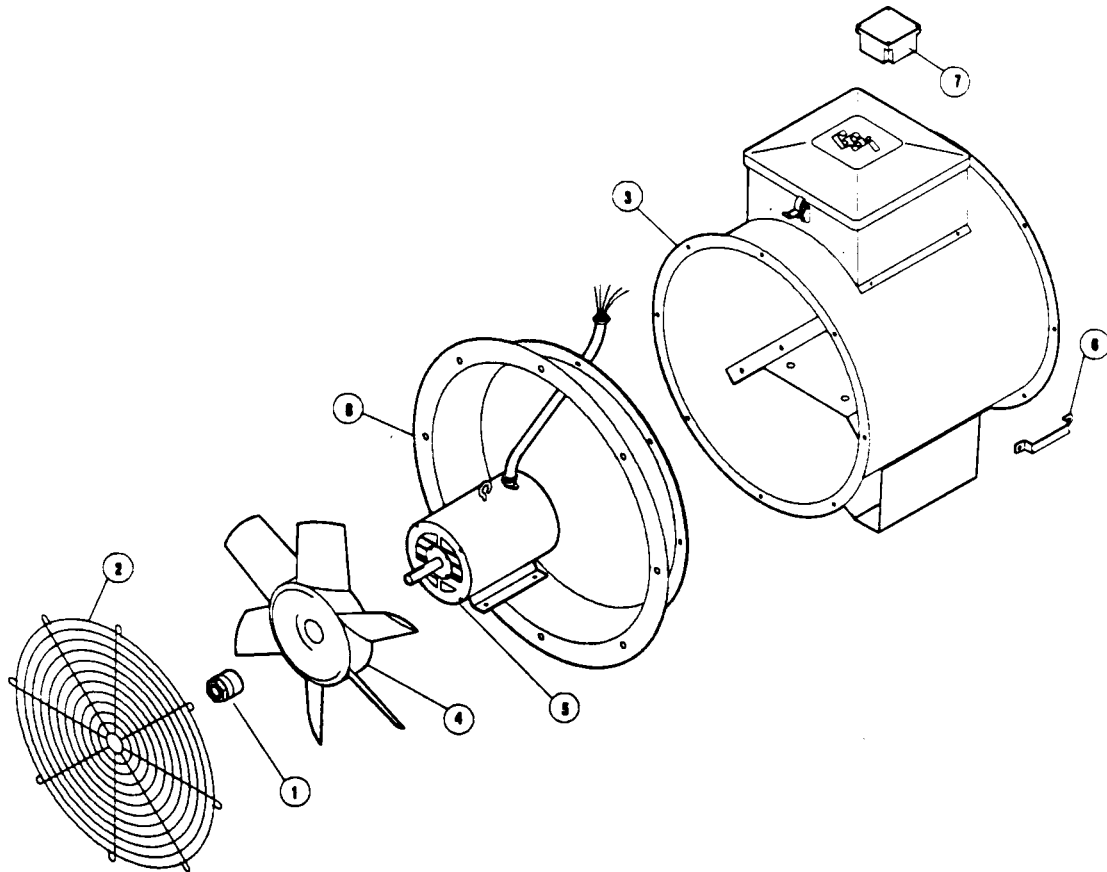

Key	Part Number	Description
1	FH-7020	Trantorque Bushing 1.1/8" Bore
2	TFH-2015	24" Grill Guard
3	F-6860	24" Fan Wrapper
3	F-6856	24" Motor Mount
3	F-6857	24" Base Leg
3	F-6859	24" Straightening Vane
4	FH-1118	5-7 HP 24" Blade and Hub Assembly
4	TF-1112	7 1/2-10 HP 24" Blade and Hub Assembly
5	FH-5645	5-7 HP 1 PH Motor
5	FH-5646	5-7 HP 3 PH Motor
5	FH-5647	7 1/2-10 HP 1 PH Motor
5	FH-5648	7 1/2-10 HP 3 PH Motor
6	PR-331	Handle
7	*FH-6972	PVC Electric Box Assembly
8	TFH-2016	24" Inlet Venturi

* Used on 3PH aeration fan models only

FAN PARTS

24" 7 HP 1 PHASE CONTROL BOX PARTS

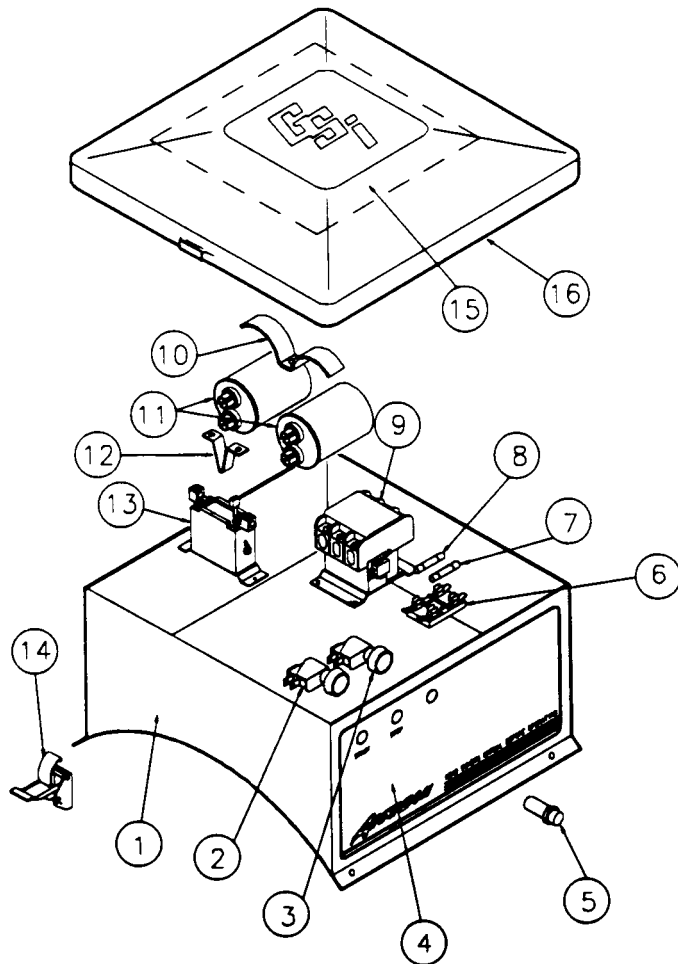

Key	Part Number	Description
1	F-6887	24" Control Box Housing
2	FH-999	Start Switch
3	FH-1000	Stop Switch
4	DC-484	Control Box Decal
5	07097476	Red Light (220V)
6	FH-1058	Fuse Holder
7	FH-1059	5 Amp Fuse
8	00147938	1/4 Amp Fuse
9	CH-1037	40 Amp Contactor
10	F-747	Capacitor Clamp
11	FH-7010	5-7 HP Capacitors (Baldor)
12	FH-5456	C330B Heat Strip
13	CH-1027	Overload Relay
14	FH-4429-1	Spring Latch
15	DC-170	Wiring Decal
16	F-942	Control Box Lid

FAN PARTS

24" 7 HP 3 PHASE CONTROL BOX PARTS

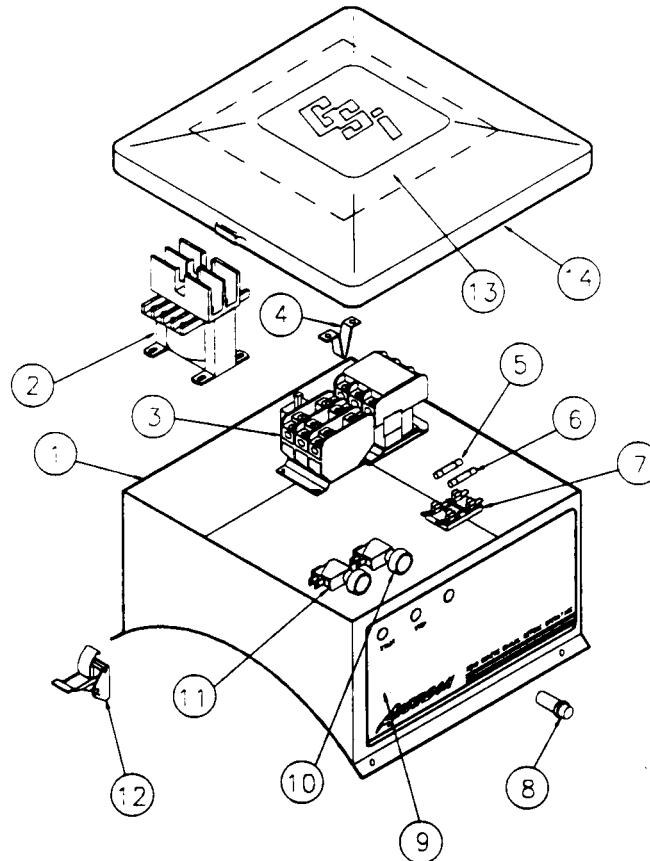

Key	Part Number	Description
1	F-6887	24" Control Box Housing
2	FH-6968	575V-110V Transformer (575V Only)
3	CH-1151	30 Amp Starter
4	FH-5443	C214B Heat Strip (230V)
4	FH-5438	C125B Heat Strip (460V)
4	FH-6971	C630A Heat Strip (575 V)
5	00147938	1/4 Amp Fuse
6	FH-1059	5 Amp Fuse
7	FH-1058	Fuse Holder
8	TFH-2021	Red Light (110V)
8	07097476	Red Light (230V)
9	DC-484	Control Box Decal
10	FH-1000	Stop Switch
11	FH-999	Start Switch
12	FH-4429-1	Spring Latch
13	DC-171	230V 3 Phase Wiring Decal
13	DC-470	575V Wiring Decal
13	DC-351	460V Wiring Decal
14	F-942	Control Box Lid

FAN PARTS

24" 10 HP 1 PHASE CONTROL BOX PARTS

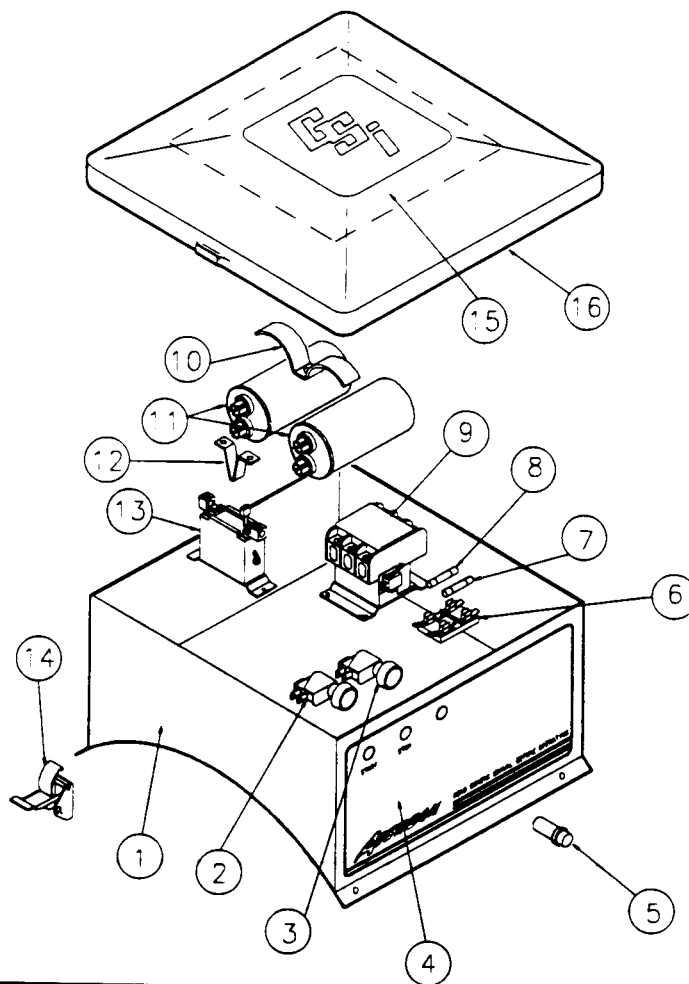

Key	Part Number	Description
1	F-6887	24" Control Box Housing
2	FH-999	Start Switch
3	FH-1000	Stop Switch
4	DC-484	Control Box Decal
5	07097476	Red Light (230V)
6	FH-1058	Fuse Holder
7	FH-1059	5 Amp Fuse
8	00147938	1/4 Amp Fuse
9	FH-2721	50 Amp Contactor
10	F-747	Capacitor Clamp
11	FH-7011	7 1/2-10 HP Capacitors (Baldor)
12	FH-5450	F487B Heat Strip
13	FH-6335	Overload Relay
14	FH-4429-1	Spring Latch
15	DC-170	Wiring Diagram Decal
16	F-942	Control Box Lid

FAN PARTS

24" 10 HP 3 PHASE CONTROL BOX PARTS

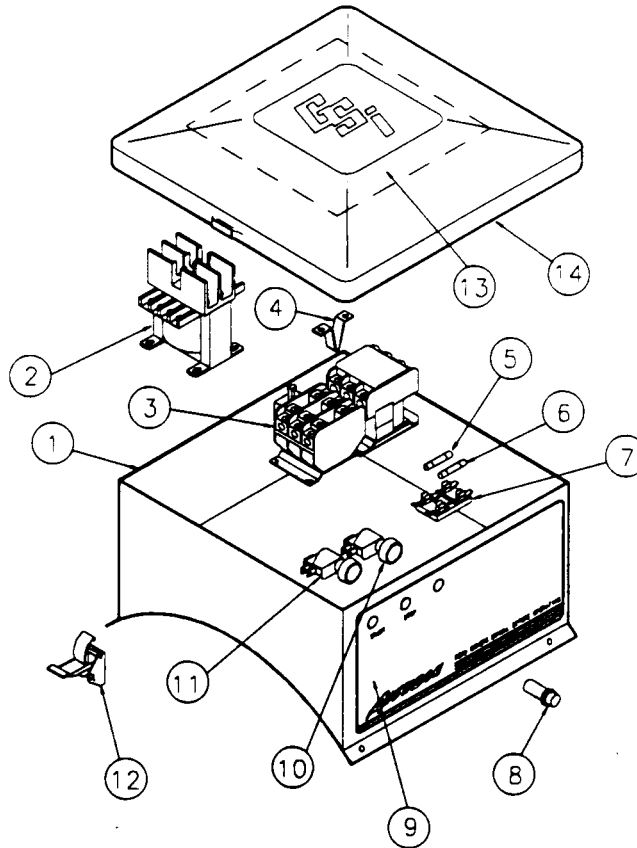

Key	Part Number	Description
1	F-6887	24" Control Box Housing
2	FH-6968	575V-110V Transformer (575V Only)
3	CH-1151	30 Amp Contactor
4	FH-5447	C303B Heat Strip (230V)
4	FH-5440	C163B Heat Strip (460 V)
4	FH-5436	C955A Heat Strip (575V)
5	00147938	1/4 Amp Fuses
6	FH-1059	5 Amp Fuse
7	FH-1058	Fuse Holder
8	TFH-2021	Red Light (110V)
8	07097476	Red Light (230V)
9	DC-484	Control Box Decal
10	FH-1000	Stop Switch
11	FH-999	Start Switch
12	FH-4429-1	Spring Latch
13	DC-171	230V 3 Phase Wiring Decal
13	DC-470	575V Wiring Decal
13	DC-351	460V Wiring Decal
14	F-942	Control Box Lid

FAN PARTS

26" FAN

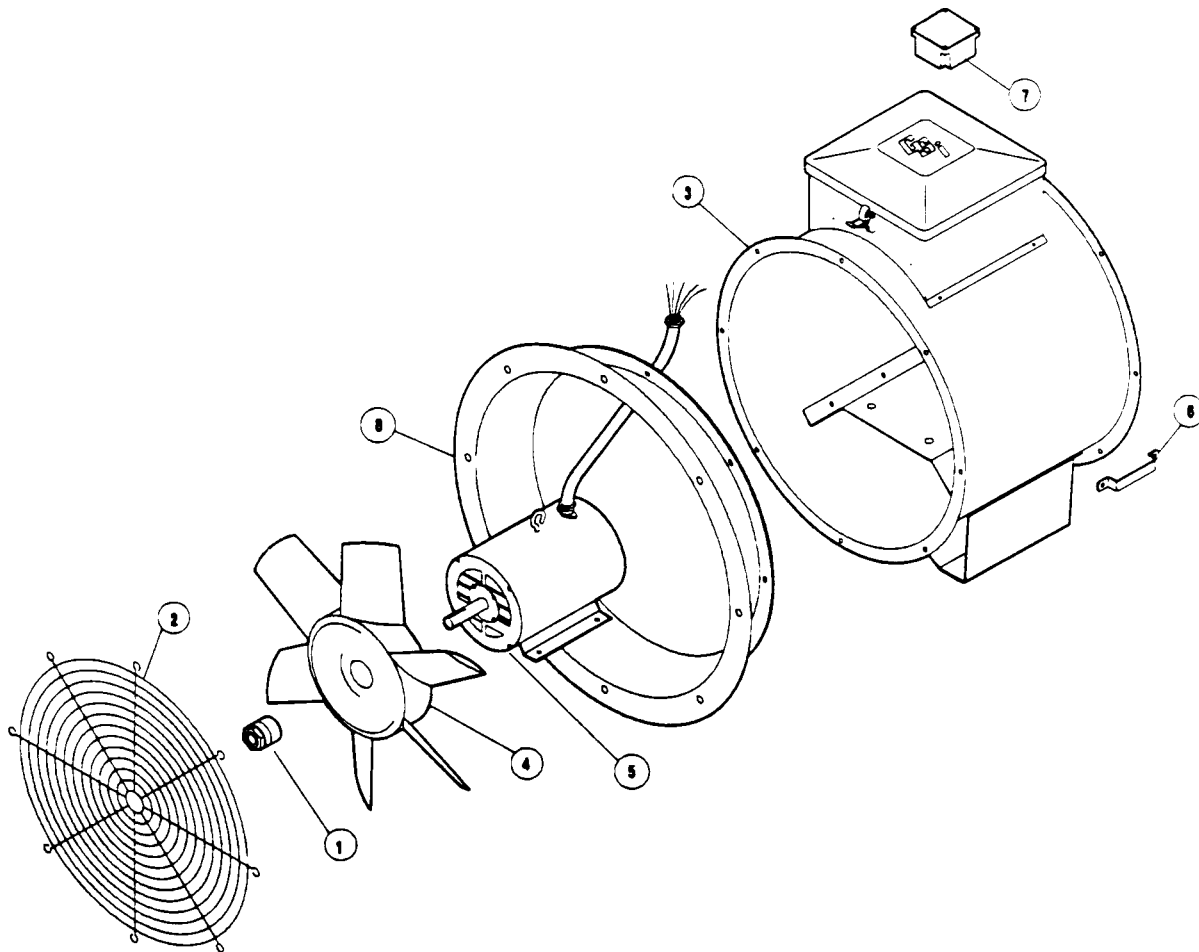

Key	Part Number	Description
1	FH-7020	Trantorque Bushing 1.1/8" Bore
2	D02-0079	26" Grill Guard
3	F-6862	26" Fan Wrapper
3	F-6857	26" Base Leg
3	F-6859	26" Straightening Vane
3	F-6861	26" Motor Mount
4	FH-1123	10-15 HP 26" Blade and Hub Assembly
5	FH-5649	10-15 HP 1 PH Motor
5	FH-5650	10-15 HP 3 PH Motor
6	PR-331	Handle
7	*FH-6972	PVC Electric Box Assembly
8	D02-0078	26" Inlet Venturi

* Used on 3PH aeration fan models only.

FAN PARTS

28" FAN

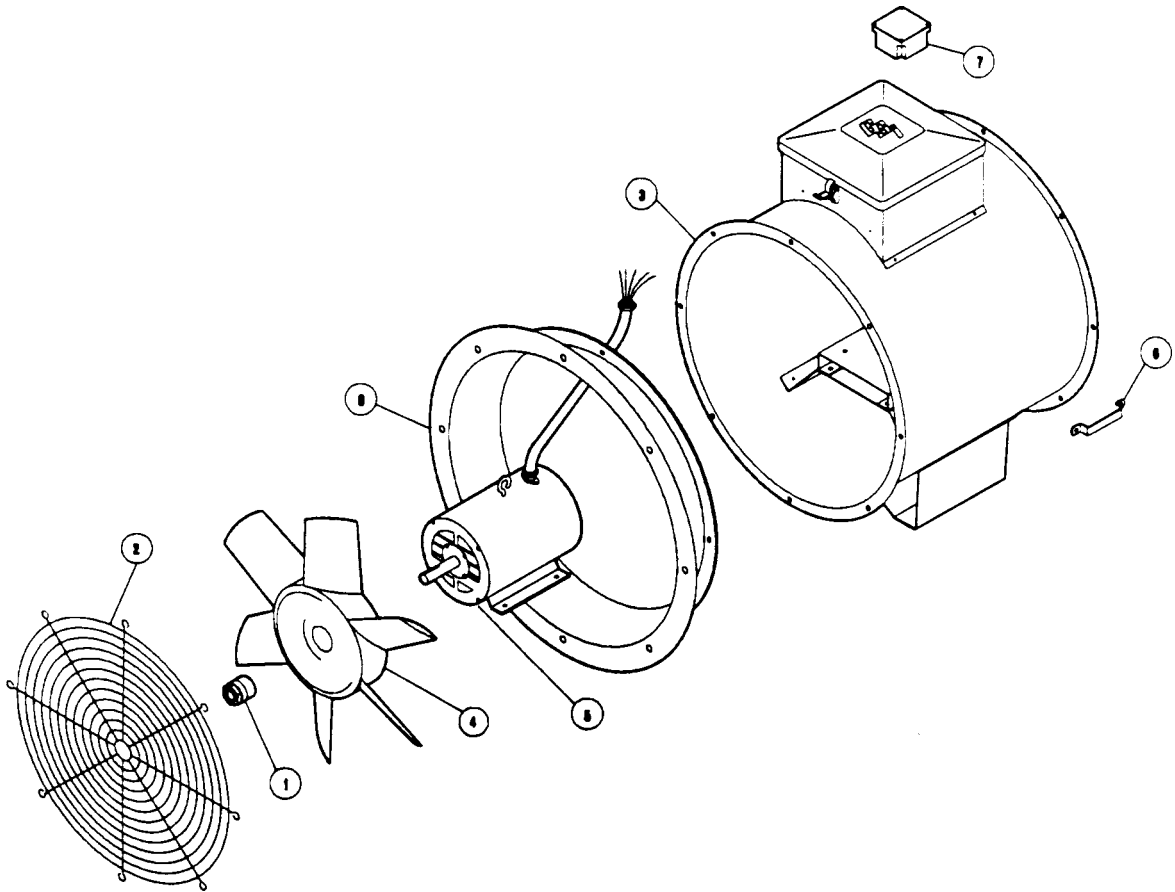

Key	Part Number	Description
1	FH-7020	Trantorque Bushing 1.1/8" Bore
2	TFH-2007	28" Grill Guard
3	F-6854	28" Fan Wrapper
3	F-6856	28" Motor Mount
3	F-6855	28" Motor Mount Adapter
3	F-6857	28" Base Leg
3	F-6858	28" Straightening Vane
4	TF-1101	10-15 HP 28" Blade and Hub Assembly
5	FH-5649	10-15 HP 1 PH Motor
5	FH-5650	10-15 HP 3 PH Motor
6	PR-331	Handle
7	FH-6972	PVC Electric Box Assembly
8	TFH-2006	28" Inlet Venturi

* Used on 3PH aeration fan models only.

FAN PARTS

26" & 28" 15 HP 1 PHASE CONTROL BOX PARTS

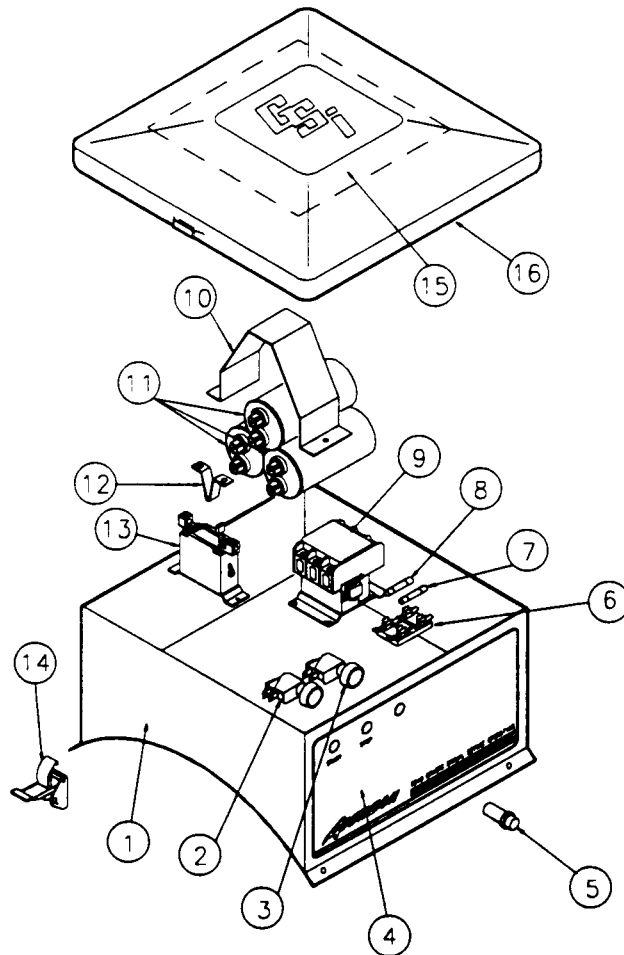

Key	Part Number	Description
1	F-6899	26" Control Box Housing
1	F-6888	28" Control Box Housing
2	FH-999	Start Switch
3	FH-1000	Stop Switch
4	DC-484	Control Box Decal
5	07097476	Red Light (230V)
6	FH-1058	Fuse Holder
7	FH-1059	5 Amp Fuse
8	00147938	1/4 Amp Fuse
9	CH-1038	60 Amp Contactor
10	TF-1238	Capacitor Clamp
11	FH-6448	10-15 HP Capacitors (Baldor)
12	FH-5452	F614B Heat Strip
13	FH-6335	Overload Relay
14	FH-4429-1	Spring Latch
15	DC-169	Wiring Diagram Decal
16	F-942	Control Box Lid

FAN PARTS

26" & 28" 15 HP 3 PHASE CONTROL BOX PARTS

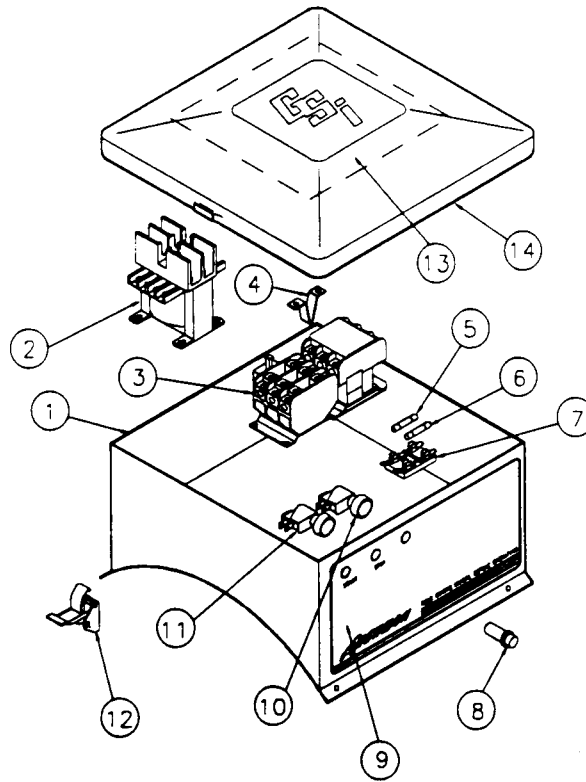

Key	Part Number	Description
1	F-6899	26" Control Box Housing
1	F-6888	28" Control Box Housing
2	FH-6968	575V-110V Transformer (575V Only)
3	CH-1151	30 Amp Starter (460 and 575V)
3	CH-1149	40 Amp Starter (230V)
4	FH-5456	C330B Heat Strip (230V)
4	FH-5441	C180B Heat Strip (460V)
4	FH-5440	C163B Heat Strip (575V)
5	00147938	1/4 Amp Fuse
6	FH-1059	5 Amp Fuse
7	FH-1058	Fuse Holder
8	TFH-2021	Red Light (110V)
8	07097476	Red Light (230V)
9	DC-484	Control Box Decal
10	FH-1000	Stop Switch
11	FH-999	Start Switch
12	FH-4429-1	Spring Latch
13	DC-171	230 V 3 Phase Wiring Decal
13	DC-470	575V Wiring Decal
13	DC-351	460V Wiring Decal
13	F-942	Control Box Lid

FAN PARTS

240 VOLT 1 PHASE (3 HP)

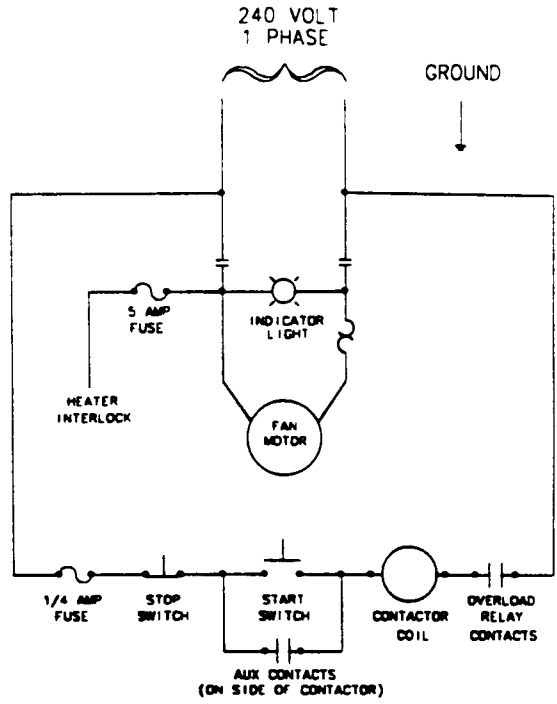

SCHEMATIC

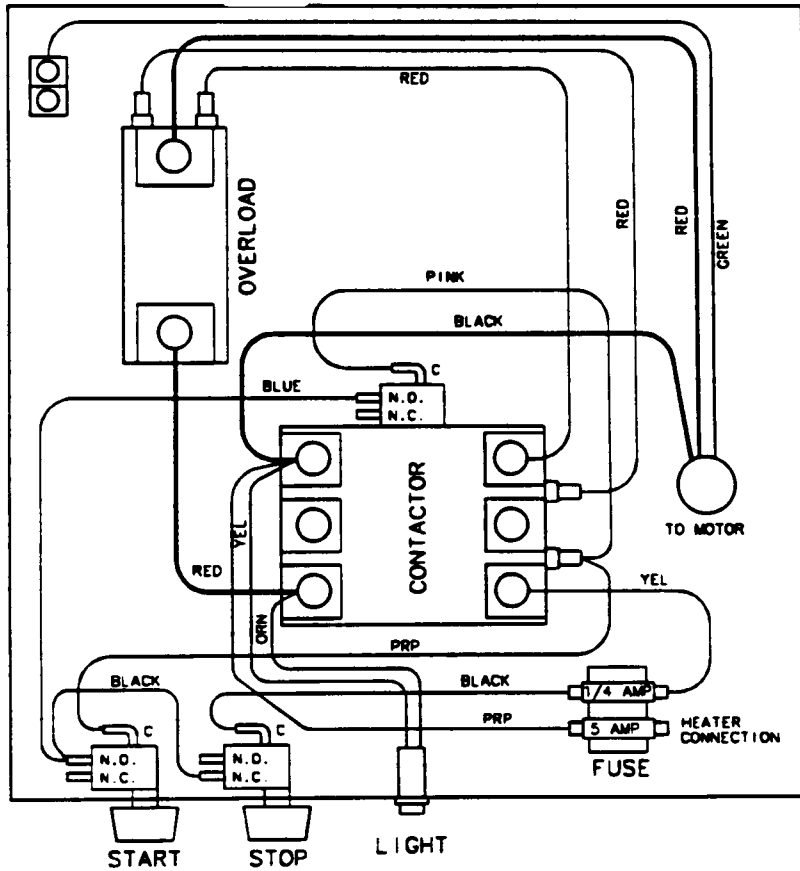

WIRING DIAGRAM

FAN PARTS

240 VOLT 1 PHASE (7 AND 10 HP)

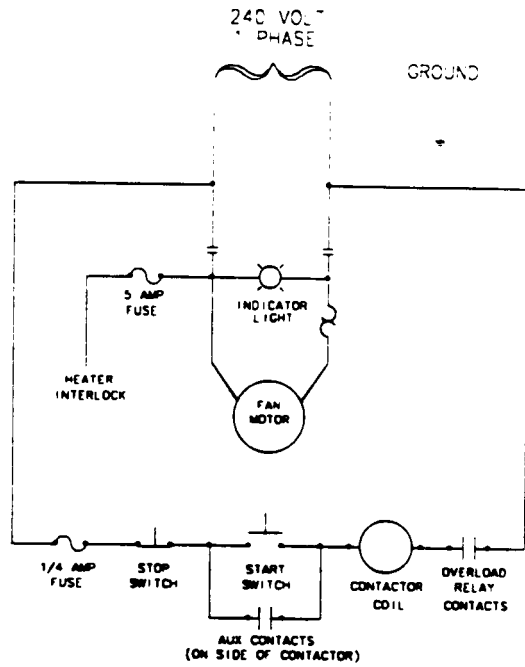

SCHEMATIC

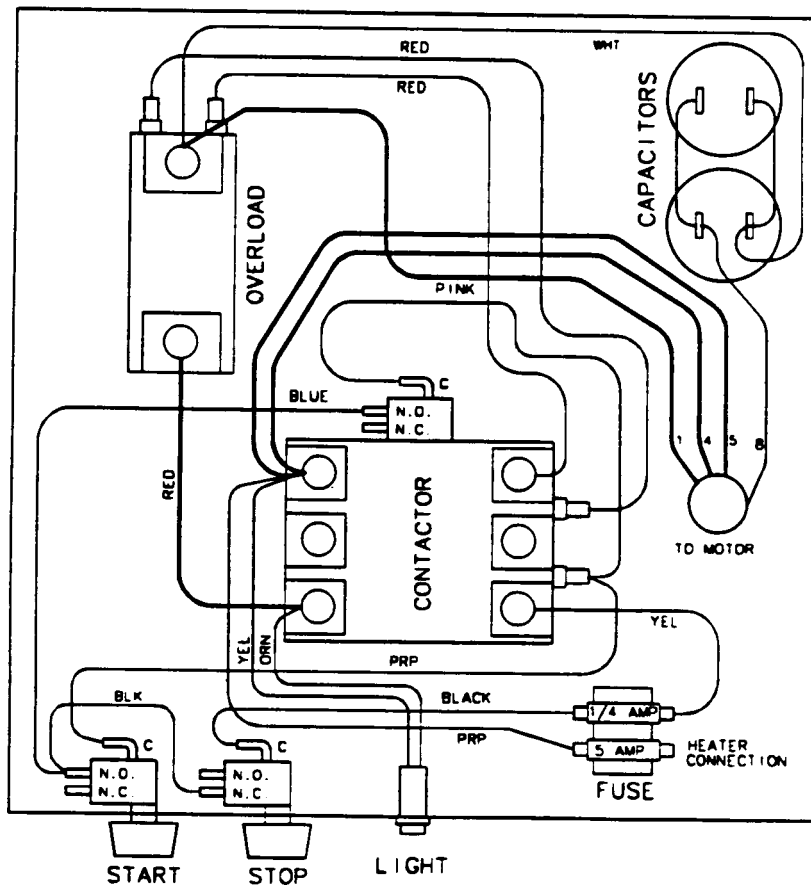

WIRING DIAGRAM

FAN PARTS

240 VOLT 1 PHASE (15 HP)

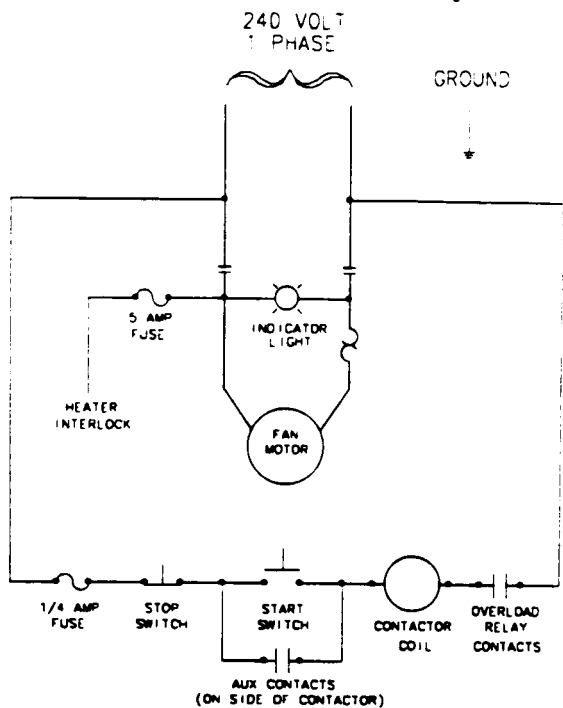

SCHEMATIC

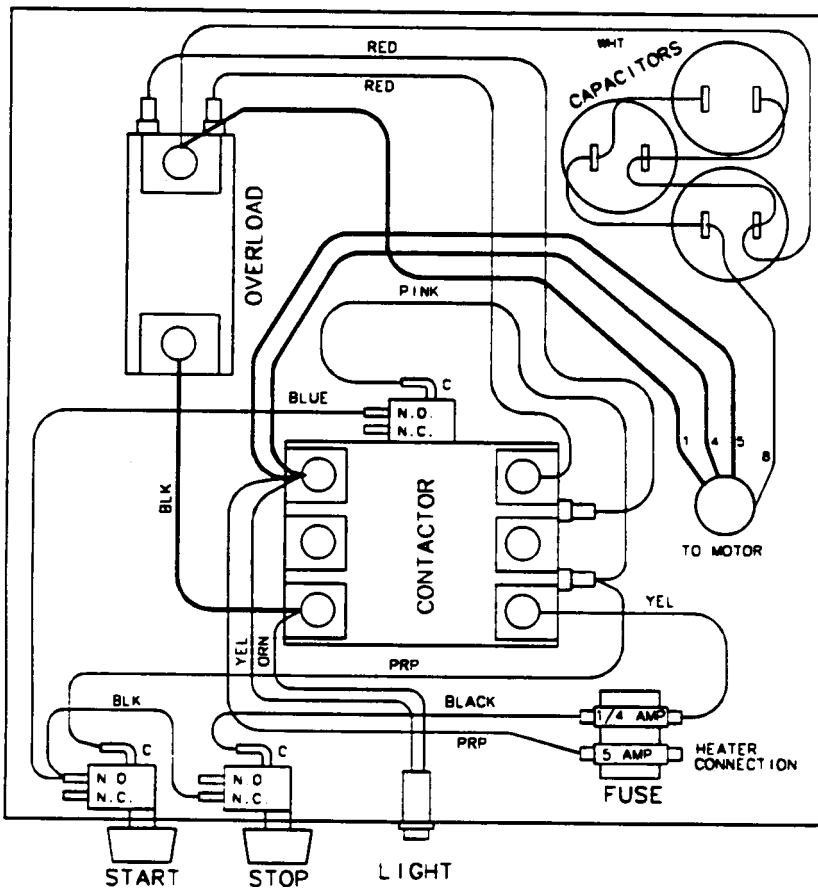

WIRING DIAGRAM

FAN PARTS

240 VOLT 3 PHASE (ALL HORSEPOWERS)

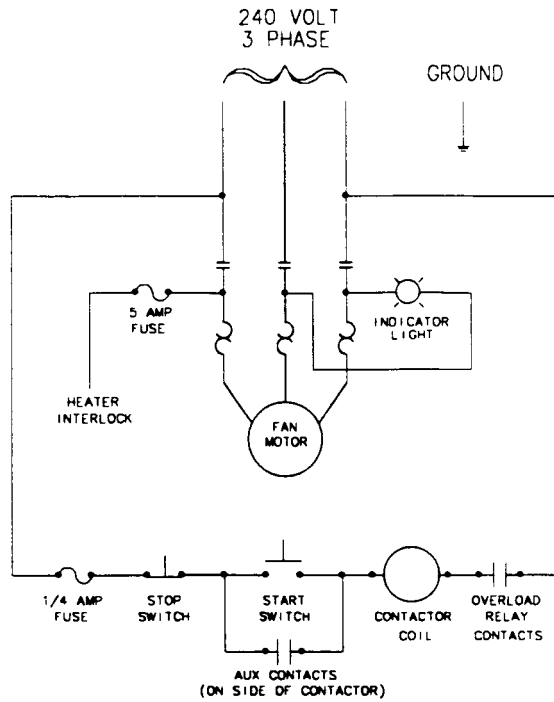

SCHEMATIC

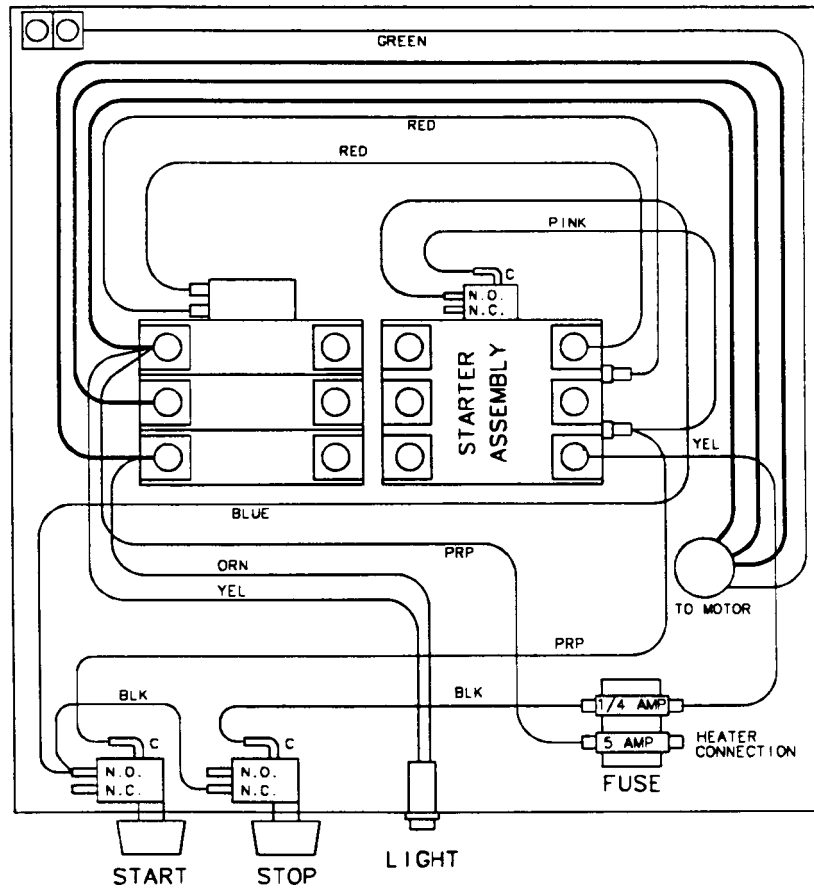

WIRING DIAGRAM

FAN PARTS

480 VOLT 3 PHASE (ALL HORSEPOWERS)

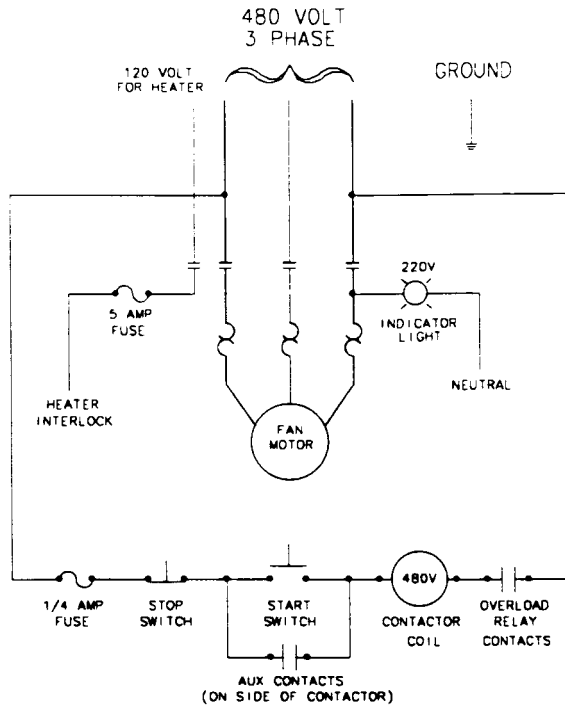

SCHEMATIC

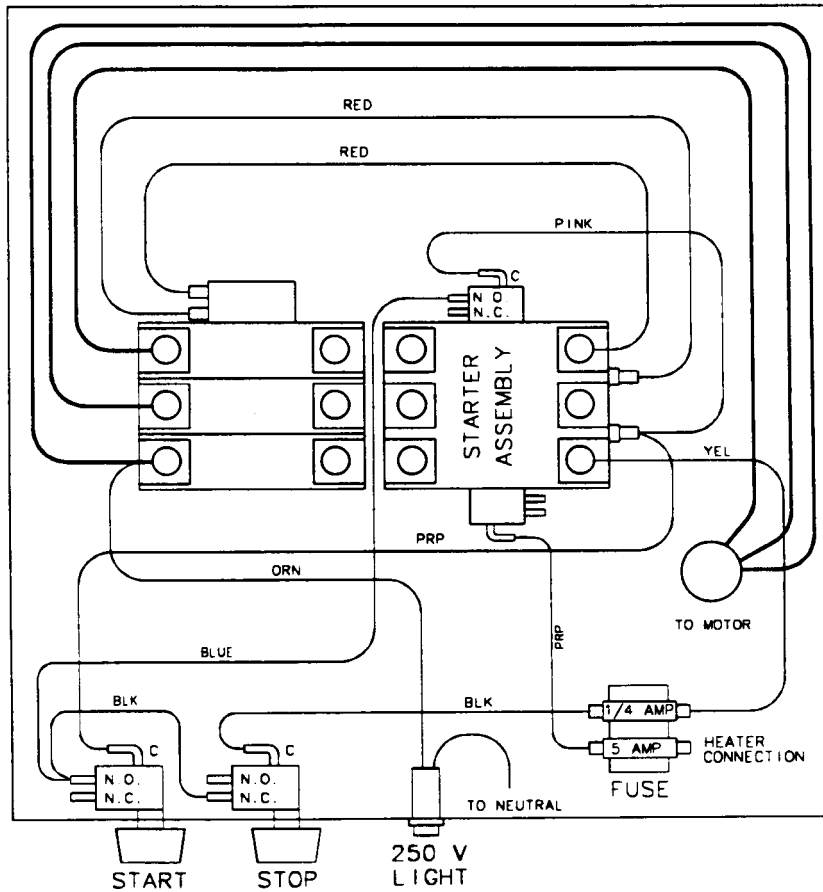

WIRING DIAGRAM

THE GSI GROUP, INC. WARRANTY

THE GSI GROUP, INC. ("GSI") WARRANTS ALL PRODUCTS WHICH IT MANUFACTURES TO BE FREE OF DEFECTS IN MATERIAL AND WORKMANSHIP UNDER NORMAL USAGE AND CONDITIONS FOR A PERIOD OF 12 MONTHS AFTER RETAIL SALE TO THE ORIGINAL END USER. THE PURCHASER'S SOLE REMEDY AND GSI'S ONLY OBLIGATION SHALL BE TO REPAIR OR REPLACE, AT GSI'S OPTION AND EXPENSE, PRODUCTS THAT, IN GSI'S SOLE JUDGMENT, CONTAIN A MATERIAL DEFECT DUE TO MATERIALS OR WORKMANSHIP. ALL DELIVERY AND SHIPMENT CHARGES TO AND FROM GSI'S FACTORY WILL BE PURCHASER'S RESPONSIBILITY. EXPENSES INCURRED BY OR ON BEHALF OF THE PURCHASER WITHOUT PRIOR WRITTEN AUTHORIZATION FROM AN AUTHORIZED EMPLOYEE OF GSI SHALL BE THE SOLE RESPONSIBILITY OF THE PURCHASER.

EXCEPT FOR THE LIMITED WARRANTY EXPRESSED ABOVE, GSI MAKES NO FURTHER WARRANTY OF ANY KIND, EXPRESS OR IMPLIED, INCLUDING, WITHOUT LIMITATION, WARRANTIES OF MERCHANTABILITY OR FITNESS FOR A PARTICULAR PURPOSE OR USE IN CONNECTION WITH (I) PRODUCT MANUFACTURED OR SOLD BY GSI OR (II) ANY ADVICE, INSTRUCTION, RECOMMENDATION OR SUGGESTION PROVIDED BY AN AGENT, REPRESENTATIVE OR EMPLOYEE OF GSI REGARDING OR RELATED TO THE CONFIGURATION, INSTALLATION, LAYOUT, SUITABILITY FOR A PARTICULAR PURPOSE, OR DESIGN OF SUCH PRODUCTS.

GSI SHALL NOT BE LIABLE FOR ANY DIRECT, INDIRECT, INCIDENTAL OR CONSEQUENTIAL DAMAGES, INCLUDING, WITHOUT LIMITATION, LOSS OF ANTICIPATED PROFITS OR BENEFITS. PURCHASER'S SOLE AND EXCLUSIVE REMEDY IS AS SET FORTH IN THE LIMITED WARRANTY EXPRESSED ABOVE, WHICH SHALL NOT EXCEED THE AMOUNT PAID FOR THE PRODUCT PURCHASED. THIS WARRANTY IS NOT TRANSFERABLE AND APPLIES ONLY TO THE ORIGINAL PURCHASER. GSI SHALL HAVE NO OBLIGATION OR RESPONSIBILITY FOR ANY REPRESENTATIONS OR WARRANTIES MADE BY OR ON BEHALF OF ANY DEALER, AGENT OR DISTRIBUTOR OF GSI.

GSI ASSUMES NO RESPONSIBILITY FOR CLAIMS RESULTING FROM ERECTION DEFECTS OR UNAUTHORIZED MODIFICATIONS TO PRODUCTS WHICH IT MANUFACTURED. MODIFICATIONS TO PRODUCTS NOT SPECIFICALLY DELINEATED IN THE MANUAL ACCOMPANYING THE EQUIPMENT AT INITIAL SALE WILL NULLIFY THE PRODUCT WARRANTY THAT MIGHT HAVE BEEN OTHERWISE AVAILABLE.

THE FOREGOING WARRANTY SHALL NOT EXTEND TO PRODUCTS OR PARTS WHICH HAVE BEEN DAMAGED BY NEGLIGENT USE, MISUSE, ALTERATION OR ACCIDENT. THIS WARRANTY EXTENDS SOLELY TO ONLY PRODUCTS MANUFACTURED BY GSI. THIS WARRANTY IS EXCLUSIVE AND IN LIEU OF ALL OTHER WARRANTIES EXPRESS OR IMPLIED. GSI RESERVES THE RIGHT TO MAKE DESIGN OR SPECIFICATION CHANGES AT ANY TIME.

PRIOR TO INSTALLATION, PURCHASER HAS THE RESPONSIBILITY TO COMPLY WITH ALL FEDERAL, STATE AND LOCAL CODES WHICH MAY APPLY TO THE LOCATION AND INSTALLATION OF PRODUCTS MANUFACTURED OR SOLD BY GSI.

THE GSI GROUP



1004 E. Illinois St.
Assumption, IL 62510
Phone 217-226-4421
Fax 217-226-4498
Toll Free Fax 800-353-8306

September 1996