OWNER'S MANUAL

CENTRIFUGAL FAN INSTALLATION AND OPERATION PNEG-163

Model #:

✓OK

- _____ 1. All wire connections
- _____ 2. Tip clearance on blade
- _____ 3. Fan blade torqued to torque specs
- _____ 4. Grill guard in place and tight
- _____ 5. Fuse in place, extra fuse provided
- _____ 6. Motor rotation correct
- _____ 7. Contactor engages properly
- _____ 8. Running amperage
- _____ 9. Vibration
- _____ 10. All fasteners tight
- _____ 11. Indicator light
- _____ 12. All decals and serial number tag
- _____ 13. Aesthetic appearance
- _____ 14. Manual

Tester Signature _____

Date _____

- Roof Warning, Operation & Safety.....4
- Safety5
- Safety.....6
- Safety alert decals7
- Safety alert decal location.....8
- Safety alert decal location.....9
- Installation Instructions.....10
 - Fan Pad Location.....10
 - Checklist Before Installing The Fan.....11
 - Installation.....11
- Fan Specifications.....12
- Fan Specifications.....13
- Fan Specifications.....14
- Fan Installation.....15
 - Machine To Earth Ground.....15
 - Proper Installation Of The Ground Rod.....15
 - Previously Installed Units.....15
- Fan Operation.....16
 - Start-Up.....16
 - Maintaining Grain Quality.....16
 - Grain Storage.....16
 - Equilibrium Moisture Chart.....16
 - Approximate Allowable Holding Time For Field-Shelled Corn.....16
 - Approximate Hours Of Fan Time To Change Bin Temperature.....17
- Fan Service.....18
 - Lubrication.....18
 - Hub Bolt Torque Requirement For Fan Blades.....19
 - Fan Troubleshooting Chart.....19
- Fan Parts.....20
 - 1750 RPM Centrifugal Fan Parts.....20
 - 3500 RPM Centrifugal Fan Parts.....21
 - 30-50HP 1750 RPM Double Inlet Centrifugal 460V.....22
 - 30-50HP 1750 RPM Centrifugal Fan..... 23
- Fan Wiring.....24
 - 240 Volt 1PH (3 And 5HP).....25
 - 240 Volt 1PH (7-1/2, 10, And 15HP).....27
 - 240 Volt 3PH (3, 5, 7-1/2, And 10HP).....29
 - 240 Volt 3PH (15, 20, 25, 30, 40, And 50HP).....31
 - 460 Volt 3PH (3, 5, 7-1/2, 10, 15, And 20HP).....33
 - 460 Volt 3PH (25, 30, 40, And 50HP).....35
 - 575 Volt 3PH (3, 5, 7-1/2, And 10HP).....37
 - 575 Volt 3PH (15, 20, 25, 30, 40, And 50HP).....39
- Notes.....40
- Warranty.....41

Record in the space provided below the Model No. and Serial No. of this product. These numbers are found on the Model and Serial Tags located on the outside of the unit.

Model No. _____

Serial No. _____

Keep these numbers for future reference.



GSI DOES NOT WARRANT ANY ROOF DAMAGE CAUSED BY EXCESSIVE VACUUM OR INTERNAL PRESSURE FROM FANS OR OTHER AIR MOVING SYSTEMS. ADEQUATE VENTILATION AND/OR "MAKEUP AIR" DEVICES SHOULD BE PROVIDED FOR ALL POWERED AIR HANDLING SYSTEMS. GSI DOES NOT RECOMMEND THE USE OF DOWNWARD FLOW SYSTEMS (SUCTION). SEVERE ROOF DAMAGE CAN RESULT FROM ANY BLOCKAGE OF AIR PASSAGES. RUNNING FANS DURING HIGH HUMIDITY/COLD WEATHER CONDITIONS CAN CAUSE AIR EXHAUST OR INTAKE PORTS TO FREEZE.

Fan Operation

Thank you for choosing a GSI product. It is designed to give excellent performance and service for many years.

This manual describes the operation of the GSI Centrifugal Fan. It is designed for medium to high static pressures, and comes equipped with either a 1750 RPM or 3450 RPM motor.

The principal concern of the The GSI Group Inc. (GSI) is your safety and the safety of others associated with grain handling equipment. This manual is written to help you

understand safe operating procedures, and some of the problems that may be encountered by the operator or other personnel.

As owner and/or operator, it is your responsibility to know what requirements, hazards and precautions exist, and to inform all personnel associated with the equipment, or who are in the area. Avoid any alterations to the equipment. Such alterations may produce a very dangerous situation, where serious injury or death may occur.

Safety Alert Symbol

The symbol shown is used to call your attention to instructions concerning your personal safety. Watch for this symbol; it points out important safety precautions. It means "ATTENTION", "WARNING", "CAUTION", and "DANGER". Read the message and be cautious to the possibility of personal injury or death.



WARNING! BE ALERT!

Personnel operating or working around electric fans should read this manual. This manual must be delivered with the equipment to its owner. Failure to read this manual and its safety instructions is a misuse of the equipment.

Electrical Safety

Provision of an adequate and safe power supply to the Centrifugal Fan unit is essential to your safety. GSI recommends that a competent and qualified electrician undertake all electrical wiring. All wiring is to be installed to the National Standards and Regulations relevant to your Country and Region.

A Mains Power Isolator should be installed with the Centrifugal Fan and is essential for your safety. This should be installed as indicated in the enclosed installation instructions and in accordance with the relevant Directives in force.

Users Manual

This manual contains information and instructions essential to the safe installation and use of this Centrifugal Fan. The manual should be read thoroughly **before** attempting any installation or use of the Centrifugal Fan. This manual should be kept with the Centrifugal Fan, or in a location where it can be readily accessed. Failure to read this manual and its safety instructions is a misuse of the equipment.

Correct Use of Your Centrifugal Fan

The Centrifugal Fan is designed solely for the purpose of ventilating agricultural products, bins and stores. Use of the system in any other way is a misuse of the system and may endanger your, or another person's, safety and health.

In the installation and use of the Centrifugal Fan, only genuine Airstream/GSI parts are to be used. Use of other non-genuine parts is a misuse of the system, and may lead to dangerous situations risking the safety and health of you and others.

This machine is not designed for use in atmospheres where the risk of explosion is foreseen. Such environments may include enclosed areas of high dust concentrations, gas, vapours and fumes. Use in such an environment is prohibited. If in doubt contact GSI or your dealer.

Safety Guards

The Centrifugal Fan contains many moving and electrical parts, which would cause serious injury, even death if touched. Guards are placed on the machine to protect you. Operating the machine at any time with the guards removed or incorrectly fitted is a serious misuse of the machine and endangers you and other people's safety.

Safety in Handling the Centrifugal Fan

Manual handling of the fans may result in serious injury. Fans are fitted with lifting eyes to facilitate mechanical handling. Generally fans should not be moved on pallet forks unless they are securely fixed to a suitable pallet to reduce the risk of the fan falling.

To Prevent injury, use suitable hand protection.

Safety in Maintenance

Whilst the Centrifugal Fan is designed to keep maintenance to a minimum, some repairs will be necessary in the course of the life of the machine. Do not attempt any repairs on the machine unless you are competent to do so. Remember that the Centrifugal Fan may in some cases operate under automatic control and will start without warning. Never attempt any work on the Centrifugal Fan without first isolating the machine from the main power, and locking the isolator so that only you can turn the power back on.

Dust

Under normal working conditions the Centrifugal Fan should create little or no dust hazard. However, dust will be created inside the bin or store if the fan is operating with a small amount of grain on the floor. This can be harmful to your health if inhaled. To prevent this, never enter the bin when the fan is operating.

Noise

Prolonged exposure to such noise without the use of hearing protection can result in serious damage to your hearing. Apart from starting and stopping the fan, there is no need for any person to work in the vicinity of the fan. If access around the fan is necessary whilst it is operating, a suitable set of ear defenders should be used.

SAFETY FIRST

General Safety Statements

The GSI Group Inc’s Principal concern is your safety and the safety of others associated with grain handling equipment. We want to keep you as a customer. This manual is to help you understand safe operating procedures and some problems which may be encountered by the operator and other personnel.

As owner and/or operator, it is your responsibility to know what requirements, hazards and precautions exist and inform all personnel associated with, or in the area of the product. Safety precautions may be required from the personnel. This product is ideal for the conditioning of corn, soy beans or other select grains. Avoid any alteration to the equipment, such alterations may produce a very dangerous situation, where serious injury or death may occur.



This is the safety alert symbol. It is used to alert you to potential personal injury hazards. Obey all safety messages that follow this symbol to avoid possible injury or death.



DANGER indicates an imminently hazardous situation which, if not avoided, will result in death or serious injury



WARNING indicates a potentially hazardous situation which , if not avoided, could result in death or serious injury.



CAUTION indicates a potentially hazardous situation which, if not avoided, may result in minor or moderate injury.



CAUTION used without the safety alert symbol indicates a potentially hazardous situation which, if not avoided, may result in property damage.

If a decal is damaged or missing contact:
 The GSI Group Inc.
 1004 E. Illinois St.
 Assumption, IL 62510
 217-226-4421
 A free replacement will be sent to you.



BE ALERT!
Danger!
 Personnel operating or working around electrical equipment should read this manual. This manual must be delivered with equipment to its owner. Failure to read this manual and its safety instructions is a misuse of the equipment.

The GSI Group Inc. recommends that you contact your local power company and have a representative review your installation so your wiring will be compatible with their system and so that you will have adequate power supplied to your unit.

Single Inlet Centrifugal Fan



Danger decals on front and back of the centrifugal fan and inside the control box.

Fan Pad Location

Fan pad should be poured 2" below the top of bin foundation for all centrifugal fans. The pad for GSI heaters is not required. If a downwind heater is to be installed at a later date, then it would be recommended to pour fan pad 48" wide and 84" long. Fan discharge should be centered on line of bin.

IMPORTANT! FAN PAD AND FAN MUST BE LEVEL AND SMOOTH FOR PROPER OPERATION. VIBRATION PROBLEMS CAN RESULT FROM IMPROPER FAN LEVELING.

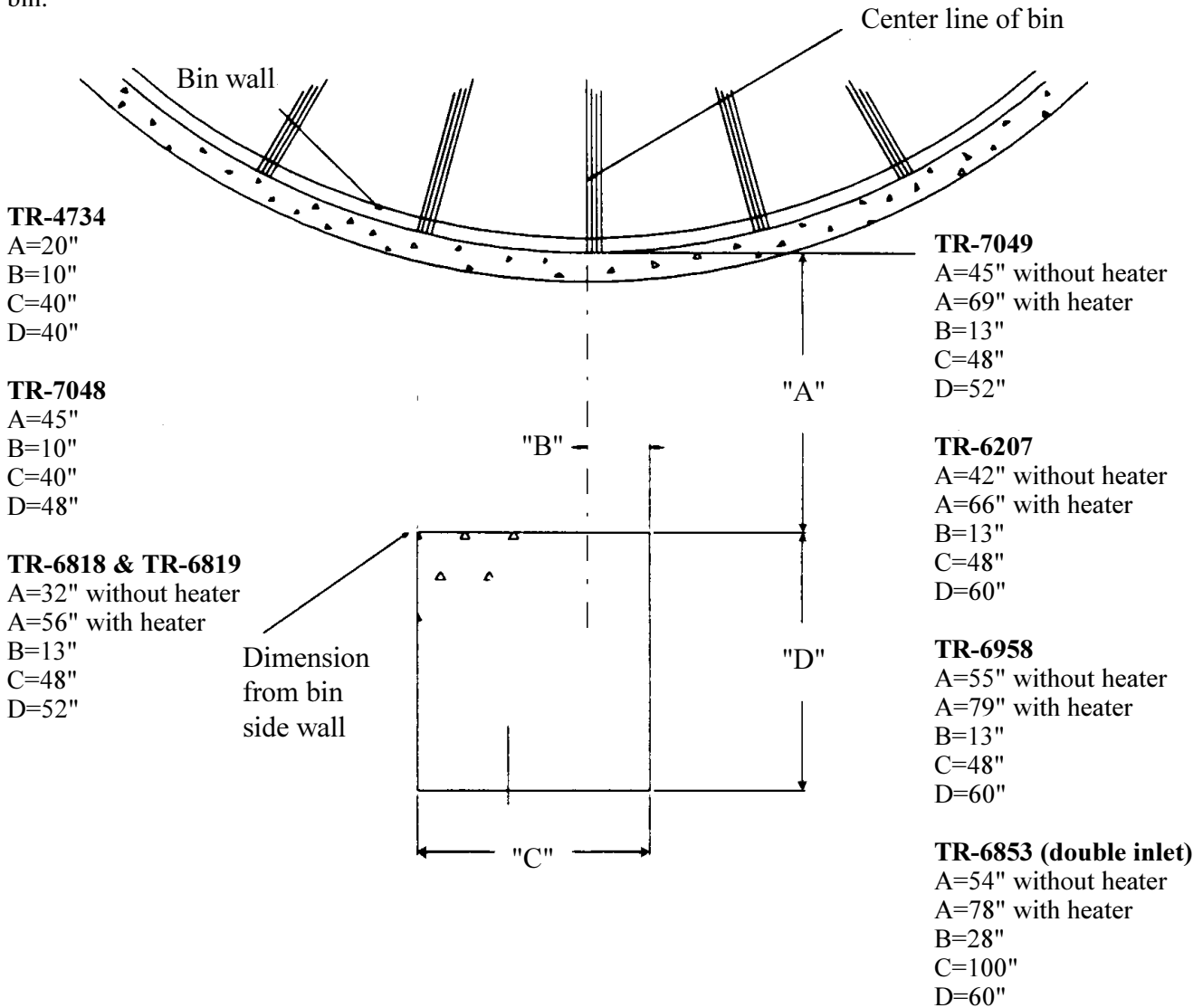

Note: Front of pad should be perpendicular to bin wall. Recommended thickness for fan pad is 4" minimum. Surface of pad should be 2" below the bin foundation. Pad for heater not required.

Figure 1: Fan pad installation guidelines.

Checklist Before Installing The Fan

1. One of the most important factors for installation is providing adequate power to run the unit. Undersized wire can lead to voltage drop and can cause motor overheating and shortened life. Therefore, it is necessary to know the distance from the unit to available transformer and the horsepower of your fan unit. These two factors will determine the size of wire needed for efficient operation. See Fan Specifications on the following pages.
2. It is recommended to contact your local power company, and have a representative survey your installation so the wiring is compatible with their system, and adequate power is supplied to your unit.
3. Each fan motor should be wired through a fused or circuit breaker disconnect switch.
4. Refer to Fan Specifications on pages 9 and 10 for the recommended slow blow fuse or breaker size to use when installing your particular fan.
5. Standard electrical safety practices and codes should be used. (Refer to National Electrical Code Standard Handbook by National Fire Protection Association).
6. A qualified electrician should make all electrical wiring installations.

Installation

1. Be sure that the disconnect and the fan are well grounded. See machine to earth ground on page 13.
2. Rotate the fan blade to be sure that it revolves easily and does not rub the housing.
3. Check all fasteners on motor mounts, fan blades and other bolted items to make sure they are tight. If any are loose, check for proper clearance and retighten fasteners. They may have loosened in shipping.
4. Fans should be mounted to set level and solid. It may be necessary to shim one or more corners of the foot mount to achieve a solid mounting. Fans not solidly mounted and properly shimmed may have excess vibration in them.
5. Check and retighten all electrical connections. They may have loosened in shipping.



**ALWAYS
DISCONNECT AND
LOCK OUT POWER
BEFORE WORKING
ON OR AROUND
HEATER**

1750 Rpm Fan Specifications

FAN HORSEPOWER	3				5				7.1/2				10			
RPM	1750															
PHASE	1		3		1		3		1		3		1		3	
VOLTS	230	230	460	575	230	230	460	575	230	230	460	575	230	230	460	575
FULL LOAD AMPS	15	12	6	3.6	25	14	7	5.5	35	22	11	7.9	40	28	14	10.2
MINIMUM WIRE SIZE	Copper Wire				Copper Wire				Copper Wire				Copper Wire			
50' RUN	10	12	14	14	8	10	12	12	8	10	12	12	6	6	10	10
100' RUN	8	12	12	12	6	10	12	12	6	10	12	12	6	6	10	10
200' RUN	6	8	10	10	4	8	12	12	4	8	12	12	4	4	8	8
300' RUN	4	6	8	8	2	6	10	10	2	6	10	10	2	3	6	6
MINIMUM WIRE SIZE	Aluminum Wire				Aluminum Wire				Aluminum Wire				Aluminum Wire			
50' RUN	8	10	12	12	6	8	10	10	6	8	10	10	4	4	8	8
100' RUN	6	10	10	10	4	8	10	10	4	8	10	10	4	4	8	8
200' RUN	4	6	8	8	2	6	10	10	2	6	10	10	2	2	6	6
300' RUN	2	4	6	6	0	4	8	8	0	4	8	8	0	2	4	4
FUSE SIZE (SLOW BLOW)	25	20	10	10	40	25	15	15	60	40	20	20	80	60	30	30
BREAKER SIZE	30	20	15	15	40	30	15	15	60	40	20	20	80	60	30	30

FAN HORSEPOWER	15				20			25			30			40			50		
RPM	1750																		
PHASE	1		3		3			3			3			3			3		
VOLTS	230	230	460	575	230	460	575	230	460	575	230	460	575	230	460	575	230	460	575
FULL LOAD AMPS	61	42	21	14	50	25	19.2	66	33	25	74	37	29	94	47	37	112	56	46
MINIMUM WIRE SIZE	Copper Wire				Copper Wire			Copper Wire			Copper Wire			Copper Wire			Copper Wire		
50' RUN	4	6	10	10	4	10	10	2	8	8	2	6	6	1	6	6	1	6	6
100' RUN	4	6	10	10	4	10	10	2	8	8	2	6	6	1	6	6	1	6	6
200' RUN	2	4	8	8	2	6	6	1	6	6	0	4	4	00	4	4	00	4	4
300' RUN	1	3	6	6	1	4	4	0	4	4	00	3	3	0000	2	2	0000	2	2
MINIMUM WIRE SIZE	Aluminum Wire				Aluminum Wire			Aluminum Wire			Aluminum Wire			Aluminum Wire			Aluminum Wire		
50' RUN	2	4	8	8	2	8	8	0	6	6	0	4	4	0	4	4	0	4	4
100' RUN	2	4	8	8	2	8	8	0	6	6	0	4	4	0	4	4	0	4	4
200' RUN	0	2	4	4	0	4	4	00	4	4	00	2	2	000	2	2	000	2	2
300' RUN	00	2	3	3	0	2	2	00	2	2	000	2	2	0000	0	0	0000	0	0
FUSE SIZE (SLOW BLOW)	80	60	30	30	80	40	40	100	60	60	150	80	80	200	100	100	200	100	100
BREAKER SIZE	100	60	30	30	80	40	40	100	60	60	150	80	80	200	100	100	200	100	100

3500 Rpm Fan Specifications

FAN HORSEPOWER	3				5				7.1/2				10			
RPM	3450								3450							
PHASE	1		3		1		3		1		3		1		3	
VOLTS	230	230	460	575	230	230	460	575	230	230	460	575	230	230	460	575
FULL LOAD AMPS	14.5	7.8	3.9	3	19.5	12	6	4.8	33	18.8	9.4	7.2	40	24	12	9.6
MINIMUM WIRE SIZE	Copper Wire				Copper Wire				Copper Wire				Copper Wire			
50' RUN	10	12	14	14	10	12	14	14	8	10	14	14	6	6	10	10
100' RUN	8	12	12	12	8	12	12	12	8	10	12	12	6	6	10	10
200' RUN	6	8	10	10	6	8	10	10	6	8	10	10	4	4	8	8
300' RUN	4	6	8	8	4	6	8	8	3	6	8	8	2	3	6	6
MINIMUM WIRE SIZE	Aluminum Wire				Aluminum Wire				Aluminum Wire				Aluminum Wire			
50' RUN	8	10	12	12	8	10	12	12	6	8	12	12	4	4	8	8
100' RUN	6	10	10	10	6	10	10	10	6	8	10	10	4	4	8	8
200' RUN	4	6	8	8	4	6	8	8	4	6	8	8	2	2	6	6
300' RUN	2	4	6	6	2	4	6	6	2	4	6	6	0	2	4	4
FUSE SIZE (SLOW BLOW)	25	20	10	10	40	25	15	15	60	40	20	20	80	60	30	30
BREAKER SIZE	30	20	15	15	40	30	15	15	60	40	20	20	80	60	30	30

FAN HORSEPOWER	15			20			30			40			50					
RPM	3450									3450								
PHASE	3			3			3			3			3					
VOLTS	230	460	575	230	460	575	230	460	575	230	460	575	230	460	575			
FULL LOAD AMPS	42	21	14	46	23	19	92	46	38	112	56	46	112	56	46			
MINIMUM WIRE SIZE	Copper Wire			Copper Wire			Copper Wire			Copper Wire			Copper Wire					
50' RUN	6	10	10	6	10	10	2	6	6	1	6	6	1	6	6			
100' RUN	6	10	10	6	10	10	2	6	6	1	6	6	1	6	6			
200' RUN	4	8	8	4	6	6	0	4	4	00	4	4	00	4	4			
300' RUN	3	6	6	3	4	4	00	3	3	0000	2	2	0000	2	2			
MINIMUM WIRE SIZE	Aluminum Wire			Aluminum Wire			Aluminum Wire			Aluminum Wire			Aluminum Wire					
50' RUN	4	8	8	4	8	8	0	4	4	0	4	4	0	4	4			
100' RUN	4	8	8	4	8	8	0	4	4	0	4	4	0	4	4			
200' RUN	2	4	4	2	4	4	00	2	2	000	2	2	000	2	2			
300' RUN	2	3	3	2	2	2	000	2	2	0000	0	0	0000	0	0			
FUSE SIZE (SLOW BLOW)	60	30	30	80	40	40	150	80	80	200	100	100	200	100	100			
BREAKER SIZE	60	30	30	80	40	40	150	80	80	200	100	100	200	100	100			

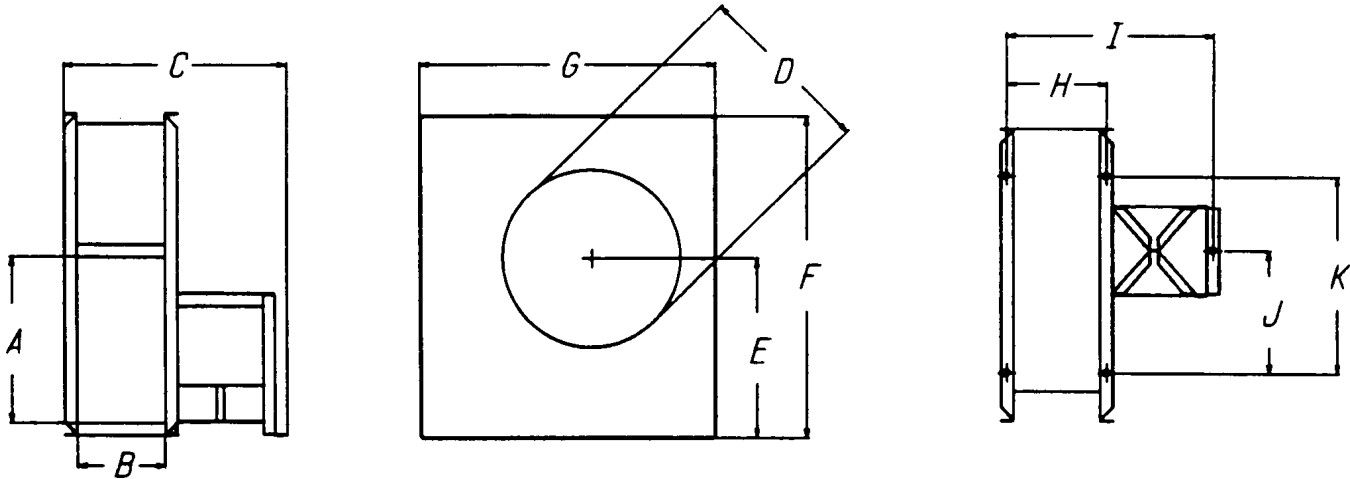

Figure 2: Fan dimensions

1750 Rpm Fan

FAN	A	B	C	D	E	F	G	H	I	J	K
3HP	23.9/16	13.1/2	41.1/8	24.7/8	25.1/4	46.13/16	42.15/16	15.11/16	31.1/8	22.7/16	37.1/16
5HP	27.3/8	14.1/4	31.1/8	27.3/8	27.3/4	51.1/8	45.1/8	16.1/2	29.3/16	19.7/16	31.3/4
7.1/2HP	27.3/8	18	34.7/8	27.3/8	27.3/4	51.1/8	45.1/8	20.1/4	32.15/16	19.7/16	31.3/4
10HP	30.1/4	16.15/16	34.3/16	30	30.3/16	54.7/16	49.9/16	19.1/8	34.13/16	20.1/2	34.5/16
15HP	30.1/4	19.1/2	39.5/16	30	30.3/16	54.7/16	49.9/16	21.11/16	34.13/16	20.1/2	34.5/16
20HP	33.1/4	19.9/16	39.9/16	33.1/2	32.15/16	56.1/2	51.3/4	21.3/4	37.7/16	22.3/8	38.7/16
25HP	33.1/4	21.7/8	41.13/16	33.1/2	32.15/16	56.1/2	51.3/4	24.1/16	39.3/4	22.3/8	38.7/16
30HP	33.1/4	21.7/8	43.3/8	36.1/2	33.3/8	58.11/16	54.5/8	23.3/8	42.5/16	23.1/4	41.5/16
40HP	33.1/4	23.11/16	45.7/8	36.1/2	33.3/8	58.11/16	54.5/8	25.13/16	44.1/8	23.1/4	41.5/16
30-50HP double	33.1/4	44	92.1/16	33.1/2	32.15/16	56.1/2	51.3/4	46.1/4	89.9/16	21.1/16	38.7/16

3500 Rpm Fan

FAN	A	B	C	D	E	F	G	H	I	J	K
3HP	16.1/2	8.1/8	26.15/16	16.1/2	17.3/8	34.13/16	32.3/4	10.3/8	24.15/16	13.15/16	22.1/8
5HP	16.1/2	10	28.13/16	16.1/2	17.3/8	34.13/16	32.3/4	12.3/16	26.13/16	13.15/16	22.1/8
7.1/2HP	19	10	29.9/16	20.1/2	20.11/16	39	37.3/16	12.3/16	27.9/16	12.11/16	20.11/16
10HP	19	11	30.9/16	20.1/2	20.11/16	39	37.3/16	13.3/16	28.9/16	12.11/16	20.11/16
15HP	19	13	32.9/16	20.1/2	20.11/16	39	37.3/16	15.3/16	30.9/16	12.11/16	20.11/16
20HP	23.9/16	12.9/16	40.3/16	24.7/8	25.1/4	46.13/16	42.15/16	14.3/4	38.3/16	18.7/16	29
30HP	23.9/16	14.1/16	41.11/16	24.7/8	25.1/4	46.13/16	42.15/16	16.1/4	39.11/16	18.7/16	29
40HP	23.9/16	16.1/2	44.1/16	24.7/8	25.1/4	46.13/16	42.15/16	18.11/16	42.1/8	18.7/16	29
50HP	27.3/8	15.3/4	45.1/16	27.3/8	27.3/4	51.1/8	45.1/8	17.15/16	43.1/8	20.1/4	32.11/16

Note: All Dimensions in inches.

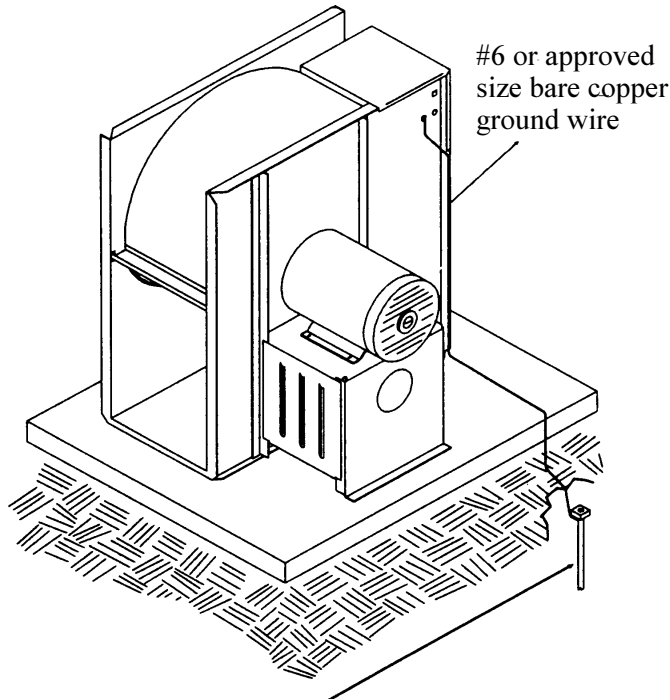

Figure 3: Use a #6 or approved size bare copper ground wire. Install a 5/8" diameter 8' long copper-clad ground rod, 2' away from the foundation and 1' below the surface of the ground or in accordance with local requirements.

Machine To Earth Ground

It is very important that a machine to earth ground rod be installed at the fan. This is true even if there is a ground at the pole 15 feet away. This ground needs to be as close to the fan as possible, but no more than 8 feet away. The ground rod should be connected to the fan control panel with at least a #6 solid bare copper ground wire, or in accordance with local requirements. The machine to earth ground provides additional safety if there is a short. It also provides the grounding necessary for long life and operation of the solid state circuit boards used on control circuits and the electronic ignition systems.

Proper Installation of the Ground Rod

(Ground rods and wires are not supplied). It is recommended that the rod not be driven into dry ground. The following steps ensure proper ground rod installation:

1. Dig a hole large enough to hold 1 to 2 gallons of water.
2. Fill hole with water.
3. Insert rod through water and jab it into the ground.
4. Continue jabbing the rod up and down, the water will work its way down the hole, making it possible to work the rod completely into the ground. This method of installing the rod gives a good conductive bond with the surrounding soil.
5. Connect the bare copper ground wire to the rod with the proper ground rod clamp.
6. Connect the bare ground wire to the fan control boxes with a grounding lug. See Figure 3.
7. Ground wire must not have any breaks or splices. Insulated wire is not recommended for grounding.

Dig a hole large enough to hold 1 or 2 gallons of water. Work the ground rod into the earth until it is completely in the ground.



Previously Installed Units

It is recommended that previously installed units be checked to see that a machine to earth ground has been installed by an electrician.

Start-up

On initial start-up of the fan, run it momentarily to make sure that the fan blade is rotating in the proper direction and airflow is correct. If not, change motor direction using instructions on the motor.

Proper installation and start-up ensures many years of trouble-free operation.

Maintaining Grain Quality

To properly maintain the quality of stored grain, it is necessary to keep the grain dry, cool and insect free. Any one of these problems can contribute to spoilage. Wet, warm grain promotes insect growth as well as grain spoilage. Cool, dry grain can keep for long periods of time.

It is recommended that the grain be kept cool (avoid freezing as freezing can reduce quality). Grain should be cooled through the fall and winter, warmed in the spring and summer.

Grain Storage

Average grain temperature should be above 35°F in the winter and below 65°F in the summer. Always try to keep the grain within 10-15°F of the average monthly outside temperature. This means grain may need to be aerated on warm days during the winter to stay above 35°F when freezing temperatures are predominate. During the summer it may be necessary to aerate the grain on cool nights, so the 65°F temperature is not exceeded during the hot days of summer.

Conditions and requirements may vary from area to area. We suggest that you contact your local Agriculture Extension Office or State Ag. University for more exact guidelines.

If the grain is to be stored more than one year, it has to be re-cooled the following fall and winter, repeating the process as long as the grain is in storage. **Frequent and regular inspection (at least weekly during fall and spring) is the best prevention against grain spoilage.**

Equilibrium Moisture Chart

Air Temperature	Percentage Relative Humidity													
	35	40	45	50	55	60	65	70	75	80	85	90	95	100
20°F	11.2	11.7	12.7	13.7	14.5	15.1	16.2	17.1	18.0	19.6	21.2	23.5	25.8	29.1
30°F	10.8	11.3	12.2	13.1	13.9	14.6	15.5	16.4	17.4	18.7	20.2	22.5	25.0	28.3
40°F	10.5	11.0	11.7	12.5	13.3	14.0	14.8	15.5	16.6	17.8	19.4	21.5	24.2	27.5
50°F	10.1	10.6	11.3	12.0	12.7	13.3	14.1	14.8	15.8	16.9	18.6	20.5	23.4	26.7
60°F	9.7	10.2	10.9	11.6	12.1	12.7	13.4	14.2	15.0	16.0	17.8	19.5	22.6	25.9
70°F	9.0	9.7	10.4	11.1	11.5	12.0	12.8	13.5	14.5	15.4	16.8	18.5	21.3	24.5
80°F	8.3	9.1	9.8	10.5	10.8	11.2	12.1	13.0	13.9	14.8	15.8	17.4	20.0	22.8

Safe moisture for normal winter storage of shelled corn is about 15%. Grain to be stored through the summer or long term, needs to be 1 to 3 points dryer.

Approximate Allowable Holding Time For Field-shelled Corn, To Maintain Grade*

Grain (°F) Temperature	15% days	18% days	20% days	22% days	24% days	26% days	28% days	30% days
40°F	898	195	85	54	38	28	24	20
50°F	451	102	46	28	19	16	13	11
60°F	242	63	26	16	10	8	6.5	5.5
70°F	147	37	13	8	5	4	3.5	3
80°F	109	27	10	6	4	3	2.5	2

*Allowable holding time for field-shelled corn at various grain temperatures and moisture

Drying fronts and/or temperature fronts move through grain at different rates depending on bin and fan size and different moistures and temperatures.

The table below lists the approximate time required to completely change the temperature of a bin. Current conditions can cause this time to vary greatly.

Therefore, this should only be used as a guide.

It may be necessary to run the fan only part of a day because of changing weather conditions. It would be necessary to run it a few hours each day on several days to complete the temperature change.

Approximate Hours Of Fan Time To Change Bin Temperature (1750 Rpm)

Fan Size H. P.	Approx. 32 ft. to eave-approx. hours of fan time required							Approx. 45 ft. to eave		
Bin Dia.	27	30	33	36	42	48	60	42	48	60
3	68	76	83	92	NR	NR	NR	NR	NR	NR
5	56	62	68	75	90	NR	NR	NR	NR	NR
7.5	51	53	58	62	72	85	NR	89	NR	NR
10	46	48	52	57	68	79	NR	82	96	NR
15	43	46	49	53	61	69	91	74	85	NR
20	NR	40	43	46	53	62	81	65	75	97
25	NR	40	40	42	48	55	72	60	68	86
30	NR	37	37	40	46	53	69	57	64	83
40	NR	38	38	39	41	47	60	52	58	76
App. BU	16,500	20,500	25,000	30,000	41,500	55,000	88,000	54,000	71,000	113,500

- Bushels are rounded and approximate.
- The hours required are based on clean grain. High moisture grain and grain containing fines or foreign material will require more time to complete the air change.
- Not Recommended: Bins in the NR range, may require fan(s) of a different size to get the cool time into the accepted range.
- Bins requiring more than 100 hours of aeration to totally change the temperature may require continuous aeration at about 1/10th cfm per bushel or some other acceptable method.

NR

Approximate Hours Of Fan Time To Change Bin Temperature (3500 Rpm)

Fan Size H. P.	Approx. 32 ft. to eave-approx. hours of fan time required									Approx. 45 ft. to eave		
Bin Dia.	21	24	27	30	33	36	42	48	60	42	48	60
3	71	82	93	NR	NR	NR	NR	NR	NR	NR	NR	NR
5	54	62	70	79	89	99	NR	NR	NR	NR	NR	NR
7.5	48	56	64	73	82	91	NR	NR	NR	NR	NR	NR
10	43	48	55	62	70	77	93	NR	NR	NR	NR	NR
15	36	40	44	50	55	61	75	89	NR	90	NR	NR
20	34	38	42	48	53	59	71	85	NR	86	NR	NR
30	NR	NR	37	41	46	51	61	72	97	74	87	NR
40	NR	NR	NR	36	40	44	52	61	81	63	74	97
50	NR	NR	NR	NR	36	39	46	54	71	56	65	85
App. BU	10,000	13,000	16,500	20,500	25,000	30,000	41,500	55,000	88,000	54,000	71,000	113,500

- Bushels are rounded and approximate.
- Not Recommended: Bins in the NR range, may require fan(s) of a different size to get the cool time into the accepted range.

NR

Motors used in the fan units are all standard NEMA frame motors and are specially designed for use in crop drying applications. Most of the replacement parts for these motors are handled by authorized service stations of the various motor manufacturers.

1. Always disconnect and lock out power before working on or around fan motor and electrical components.
2. Malfunctioning electrical components should be checked by a qualified electrician.
3. For extra motor life, any electric motor should be run for 30 minutes, once a month. This will help eliminate any damaging moisture

build-up in the motor and bearings.

4. Fans setting idle in the summer offer an excellent place for mud doblers to build their nests. A mud dobber nest on the back of the fan blade will cause the fan to be out of balance and vibrate.

Lubrication

This is a ball bearing motor. The bearings have been given initial lubrication at the factory. Motors without regreasing capability are factory lubricated for normal bearing life.

Relubrication Intervals (Motors With Regreasing Capability)

New motors having been in storage for over a year should be relubricated by the procedure noted in the chart to ensure long operating life.

Lubricant

Baldor motors are pre-greased normally with Shell Oil Company's "Dolium R". Several equivalent greases which are compatible with the Baldor furnished grease are Chevron Oil's "SRI No. 2" and Texaco Inc.'s "Premium RB".

Procedure

Overgreasing bearings can cause pre-

Hours of Service Per Year	Suggested Relube Interval		
	Nemaframe Size		
	42 to 215T	254 to 326T	364 to 447T
5000 Hrs.	215T	3 years	1 years
Continuous Normal Application	5 years	1 years	9 months
Seasonal Service Motor is idle for 6 months or more	2 years 1 year (beginning of season)	1 year (beginning of season)	1 year (beginning of season)
Continuous high ambients, dirty or moist locations, high vibration or where shaft end is hot (pumps-fans)	6 months	6 months	3 months

mature bearing failure. If motor is equipped with Alemite fitting, clean tip of fitting and apply grease gun. Use 1 to 2 full strokes on motors in NEMA 215 frame and smaller. Use 2 to 3 strokes on NEMA 254 thru NEMA 365 frame. Use 3 to 4 strokes on NEMA 404 frames and larger. On motors having drain plugs, remove grease drain plug and operate motor for 20 minutes before replacing drain plug.

On motors equipped with slotted head grease screw, remove screw and apply grease tube to hole. Insert 2 to 3 inch length of grease string into each hole on motors in NEMA 215 frame and smaller. Insert 3 to 5 inch length on larger motors. Motors having grease drain plugs, remove plug and operate motor for 20 minutes before replacing drain plug. **Keep grease clean. Lubricate motors at standstill. Remove and replace drain plugs at standstill. Do not mix petroleum grease and silicone grease in motor bearings.**

Hub Bolt Torque Requirement For Fan Blades

A. 3-15HP 3500RPM fans.....16ft. lbs. (Browning)

B. 20-50HP 3500RPM fans.....29ft. lbs. (Browning)

C. 3-50HP 1750RPM fans.....29ft. lbs. (Browning)

Fan Troubleshooting Chart

SYMPTOM	POSSIBLE CAUSE	SOLUTION
Fan will not run	Blown fuse or breaker in disconnect switch Main power not turned on Defective wiring or loose connection Incorrect wire size Overload kicked out Defective motor Defective magnetic contactor	Replace fuses or reset breakers Turn power on at all disconnects ahead of the unit Follow wiring diagram and tighten any loose connections See wire size charts for proper wire size and change if needed Check manual reset, push in to reset Replace motor Check the magnetic contactor
Fan runs for a short period of time then shuts off	Undersize wiring Low line voltage at the installation. Power failure Magnetic contactor malfunctioning Defective start/stop button Overload setting incorrect	Check to see that power supply wires are the proper size, contact your local power company. Call power company after making sure wire size is correct Change magnetic contactor Replace necessary part Adjust overload to proper setting
Fan makes ticking noise	Fan blade hitting fan housing Motor bearing bad	Stop fan and turn off electricity. Remove fan screen and check to see if fan blade is hitting the housing. Adjust motor position to obtain proper clearance. Replace motor bearing
Fan vibrates	Fan not level Fan has dirt deposit on blade Motor shaft is bent Blade not mounted properly on shaft Blade out of balance	Level fan Clean blade Replace motor Mount blade properly on shaft Replace or have blade rebalanced

1750 RPM Centrifugal Fan Parts

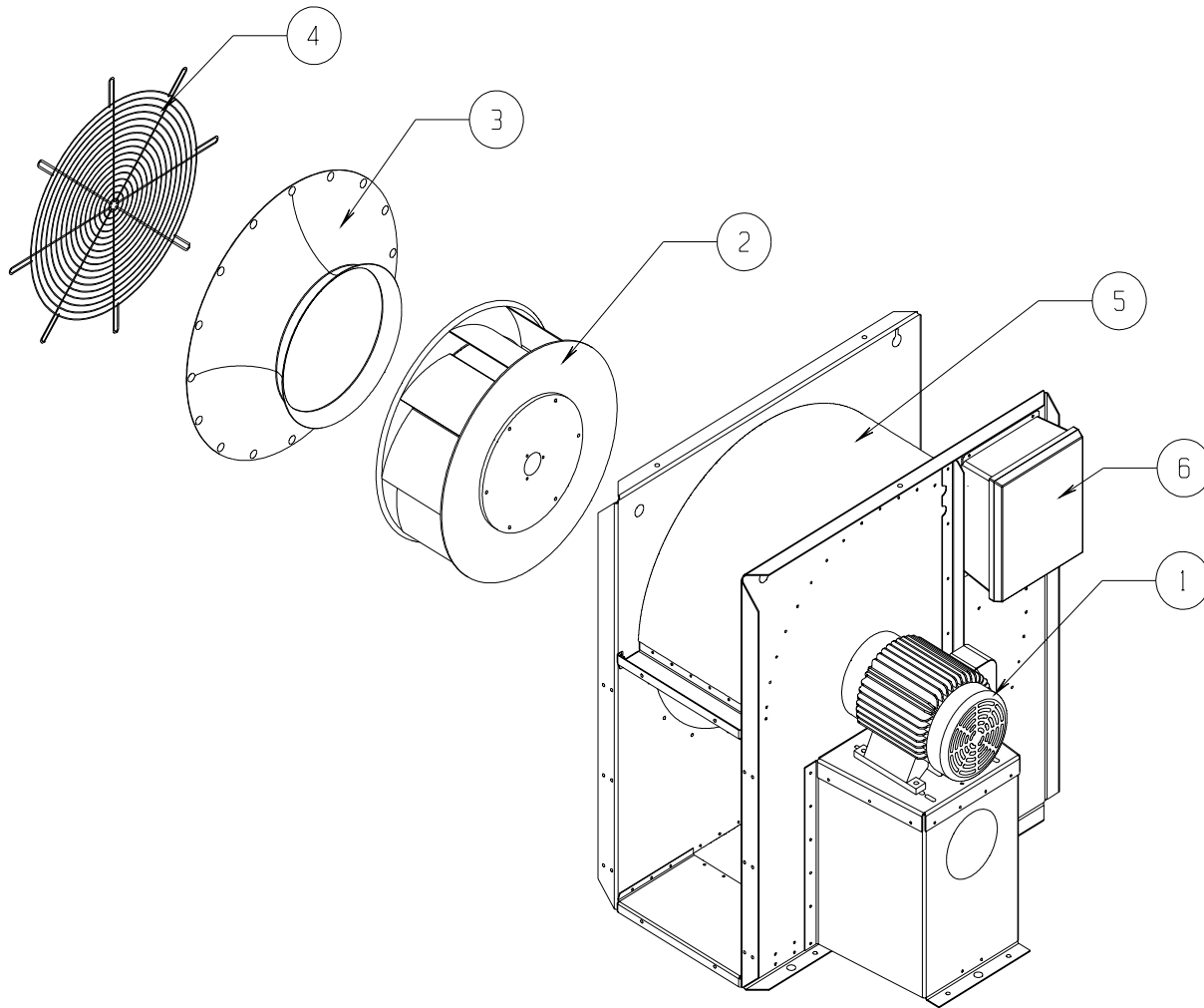

Key	Part Number									Description
	3HP	5HP	7.5HP	10HP	15HP	20HP	25HP	30HP	40HP	
1	CH-6879	CH-1044	CH-1046	CH-1048	CH-5753					1 Phase motor
1	CH-6866	CH-1045	CH-1047	CH-1049	CH-1050	CH-1051	C-2049	TFH-2011	CH-6848	3 Phase Motor
2	CH-6878	C-956	C-957	C-958	C-960	CH-2076	C-2046	C-7319	C-7320	Blade and Hub Assembly
3	FH-5473	C-962	C-962	C-963	C-963	CH-2047	CH-2047	CH-6876	CH-6876	Inlet Cone
4	FH-5488	CH-3692	CH-3692	F-3530	F-3530	CH-6877	CH-6877	CH-6877	CH-6877	Grill Guard
5	C-7062	C-7068	C-7069	C-7070	C-7071	C-7072	C-7073	C-7067	C-7127	Housing Assembly
6	IEBCF-3-1	IEBCF-5-1	IEBCF-7.5-1	IEBCF-10-1	IEBCF-15-1					230V 1Ph Control Box Assembly
6	IEBCF-3-3	IEBCF-5-3	IEBCF-7.5-3	IEBCF-10-3	IEBCF-15-3	IEBCF-20-3	IEBCF-25-3	IEBCF-30-3	IEBCF-40-3	230V 3Ph Control Box Assembly
6	IEBCF-3-4	IEBCF-5-4	IEBCF-7.5-4	IEBCF-10-4	IEBCF-15-4	IEBCF-20-4	IEBCF-25-4	IEBCF-30-4	IEBCF-40-4	460V 3Ph Control Box Assembly
6	IEBCF-3-5	IEBCF-5-5	IEBCF-7.5-5	IEBCF-10-5	IEBCF-15-5	IEBCF-20-5	IEBCF-25-5	IEBCF-30-5	IEBCF-40-5	575V 3Ph Control Box Assembly

3500 RPM Centrifugal Fan Parts

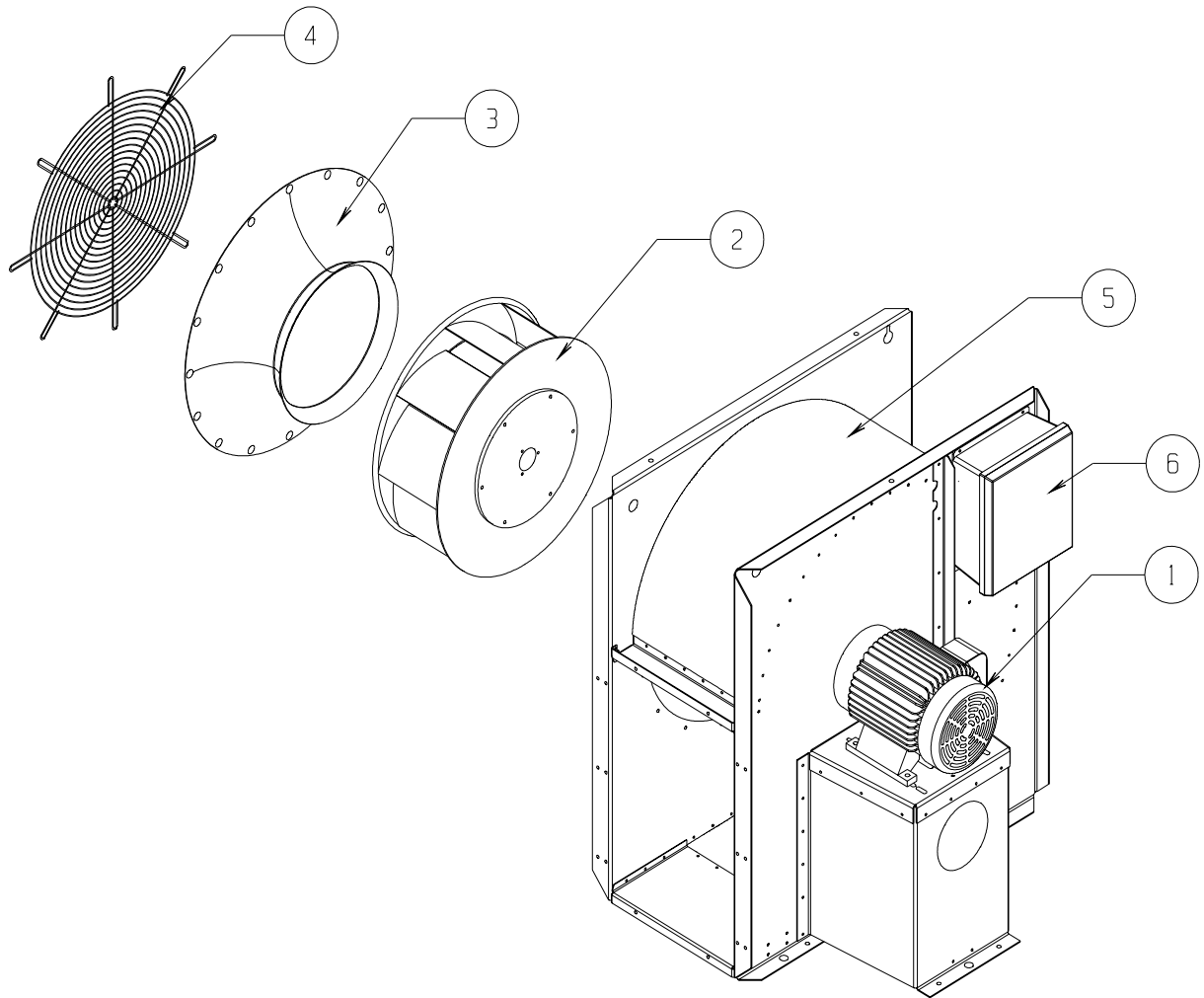

Key	Part Number									Description
	3HP	5HP	7.5HP	10HP	15HP	20HP	30HP	40HP	50HP	
1	FH-5474	FH-5476	FH-5478	FH-5480						1 Phase motor
1	FH-5475	FH-5477	FH-5479	FH-5481	FH-5483	FH-5484	FH-5485	CH-5582	CH-5583	3 Phase Motor
2	FH-5464	FH-5465	FH-5466	FH-5467	FH-5468	FH-5469	FH-5470	FH-5758	CH-5852	Blade and Hub Assembly
3	FH-5471	FH-5471	FH-5472	FH-5472	FH-5472	FH-5473	FH-5473	FH-5473	C-962	Inlet Cone
4	FH-5486	FH-5486	FH-5487	FH-5487	FH-5487	FH-5488	FH-5488	FH-5488	CH-3692	Grill Guard
5	C-7090	C-7091	C-7092	C-7093	C-7094	C-7095	C-7096	C-7097	C-7198	Housing Assembly
6	IEBCF-3-1	IEBCF-5-1	IEBCF-7.5-1	IEBCF-10-1						230V 1Ph Control Box Assembly
6	IEBCF-3-3	IEBCF-5-3	IEBCF-7.5-3	IEBCF-10-3	IEBCF-15-3	IEBCF-20-3	IEBCF-30-3	IEBCF-40-3	IEBCF-50-3	230V 3Ph Control Box Assembly
6	IEBCF-3-4	IEBCF-5-4	IEBCF-7.5-4	IEBCF-10-4	IEBCF-15-4	IEBCF-20-4	IEBCF-30-4	IEBCF-40-4	IEBCF-50-4	460V 3Ph Control Box Assembly
6	IEBCF-3-5	IEBCF-5-5	IEBCF-7.5-5	IEBCF-10-5	IEBCF-15-5	IEBCF-20-5	IEBCF-30-5	IEBCF-40-5	IEBCF-50-5	575V 3Ph Control Box Assembly

30-50HP 1750 RPM DOUBLE INLET CENTRIFUGAL FAN PARTS

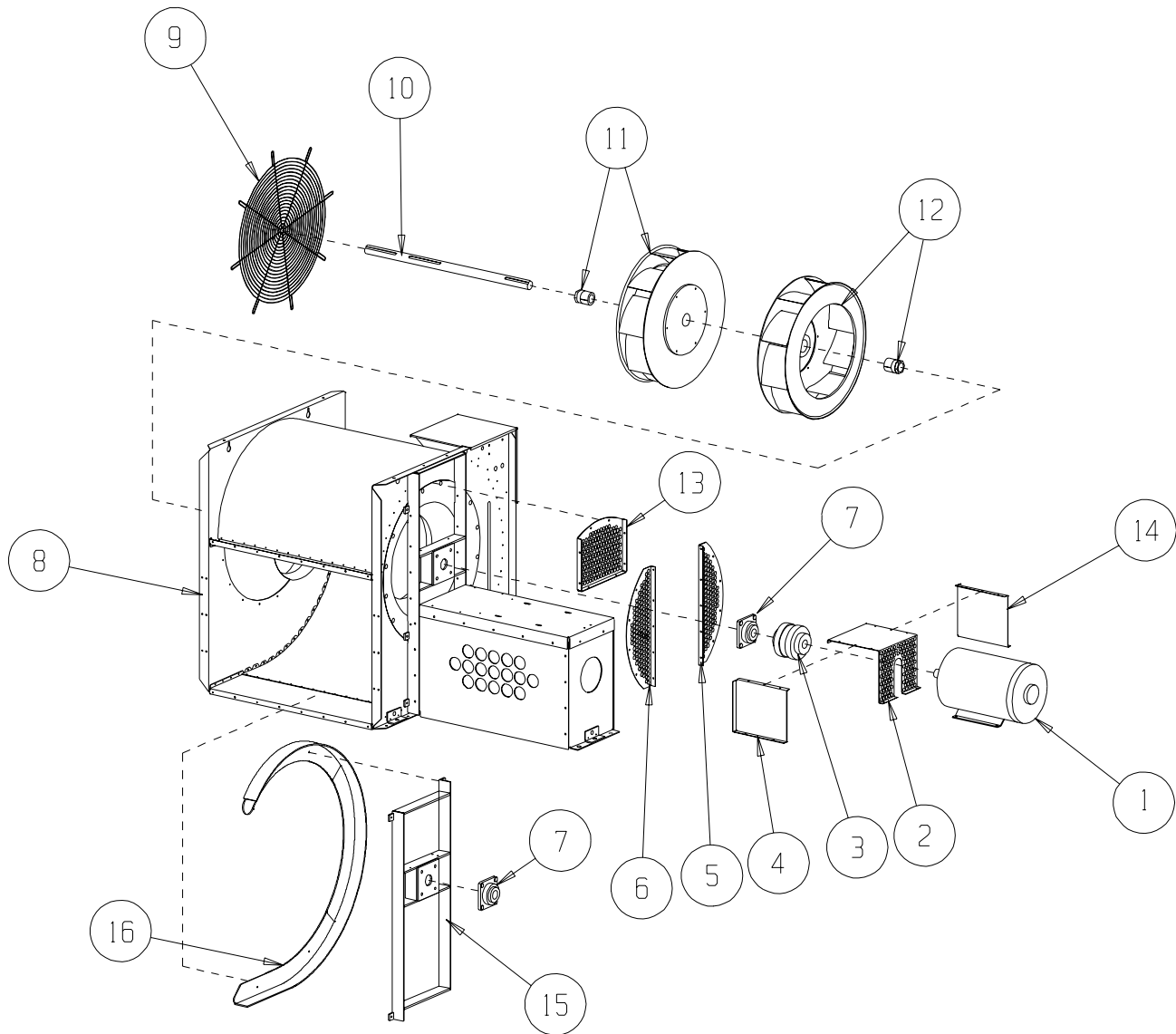

30-50HP 1750RPM DOUBLE INLET CENTRIFUGAL FAN PARTS

Key	Part Number	Description
1	TFH-2011	30 HP 3 PH Centrifugal Fan Motor
1	CH-6848	Motor 40 HP 3 PH
1	CH-6863	Motor 50 HP 3 PH
2	C-7464	Coupling Guard Top 30 HP
2	C-7443	Coupling Guard Top 40 & 50 HP
3	C-7423	Coupling Insert Type S Size 10
3	C-7422	Coupling Type S Size 10 2" Bore
3	C-7424	Coupling Type S Size 10 2.1/8" Bore
3	C-7425	Coupling Type S size 10 1.7/8" Bore
4	C-7445	Coupling Guard Left-Hand 30 HP
4	C-7447	Left-Hand Coupling Guard Side 40 & 50HP
5	C-7449	Right-Hand Motor Inlet Guard
6	C-7450	Left-Hand Motor Inlet Guard
7	C-7293	Bearing Flange 4 Bolt 2" Bore
8	C-7312	30-50 HP Double Inlet Direct Drive Housing
9	C-7754-Y	33" Inlet Cone (ochre)
10	C-7311	Double Inlet Drive Shaft
11	C-7041	Double Inlet Blade Standard 30 HP & Hub
11	C-7044	Double Inlet Blade Standard 50 HP & Hub
11	C-6931	Double Inlet Blade Standard 40 HP & Hub
12	C-7045	Double Inlet Blade Reverse 50 HP & Hub
12	C-7042	Double Inlet Blade Reverse 30 HP & Hub
12	C-6930	Double Inlet Blade Reverse 40 HP & Hub
13	C-7448	Top Motor Inlet Guard-Double Inlet Cent.
14	C-7444	Coupling Guard Right-Hand 30 HP
14	C-7446	Right-Hand Coupling Guard Side-40 & 50HP
15	C-7712	Internal Bearing Mount Weldment
16	C-7709	Bearing Arch Weldment

240 Volt 1 Phase Wiring Schematic

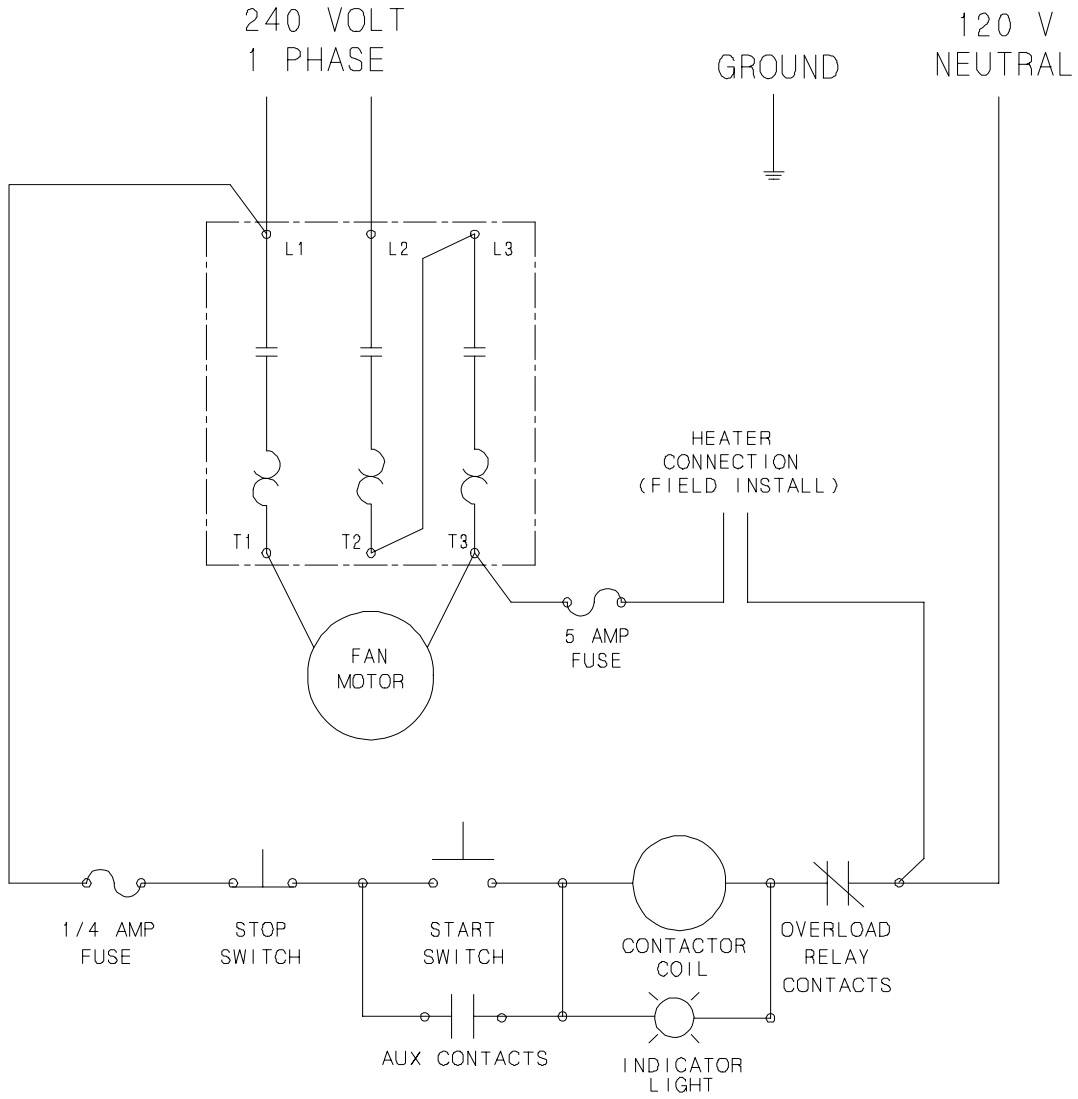

3, 5HP 1 Phase 240 Volt Wiring Diagram and Parts

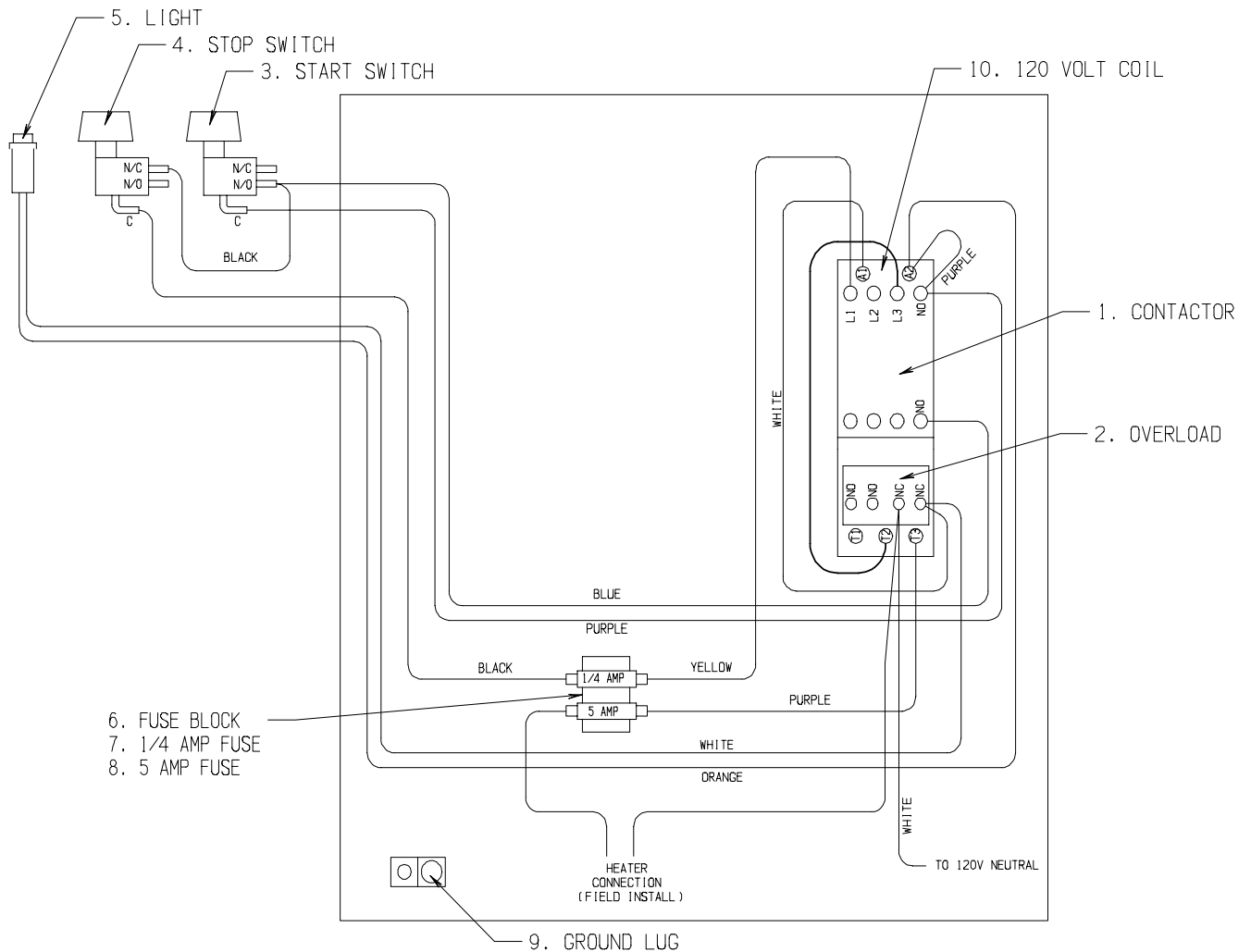

Key	Part Number		Description
	3HP	5HP	
1	D03-0492	D03-0492	Contactor
2	D03-0476	D03-0479	Overload
3	FH-999	FH-999	Start Switch
4	FH-1000	FH-1000	Stop Switch
5	TFH-2021	TFH-2021	Light
6	FH-1058	FH-1058	Fuse Block
7	00147938	00147938	1/4 Amp Fuse
8	FH-1059	FH-1059	5 Amp Fuse
9	FH-6634	FH-6634	Ground Lug
10	D03-0670	D03-0670	120 Volt Coil
	D03-0511	D03-0511	Auxiliary Contacts

240 Volt 1 Phase Wiring Schematic

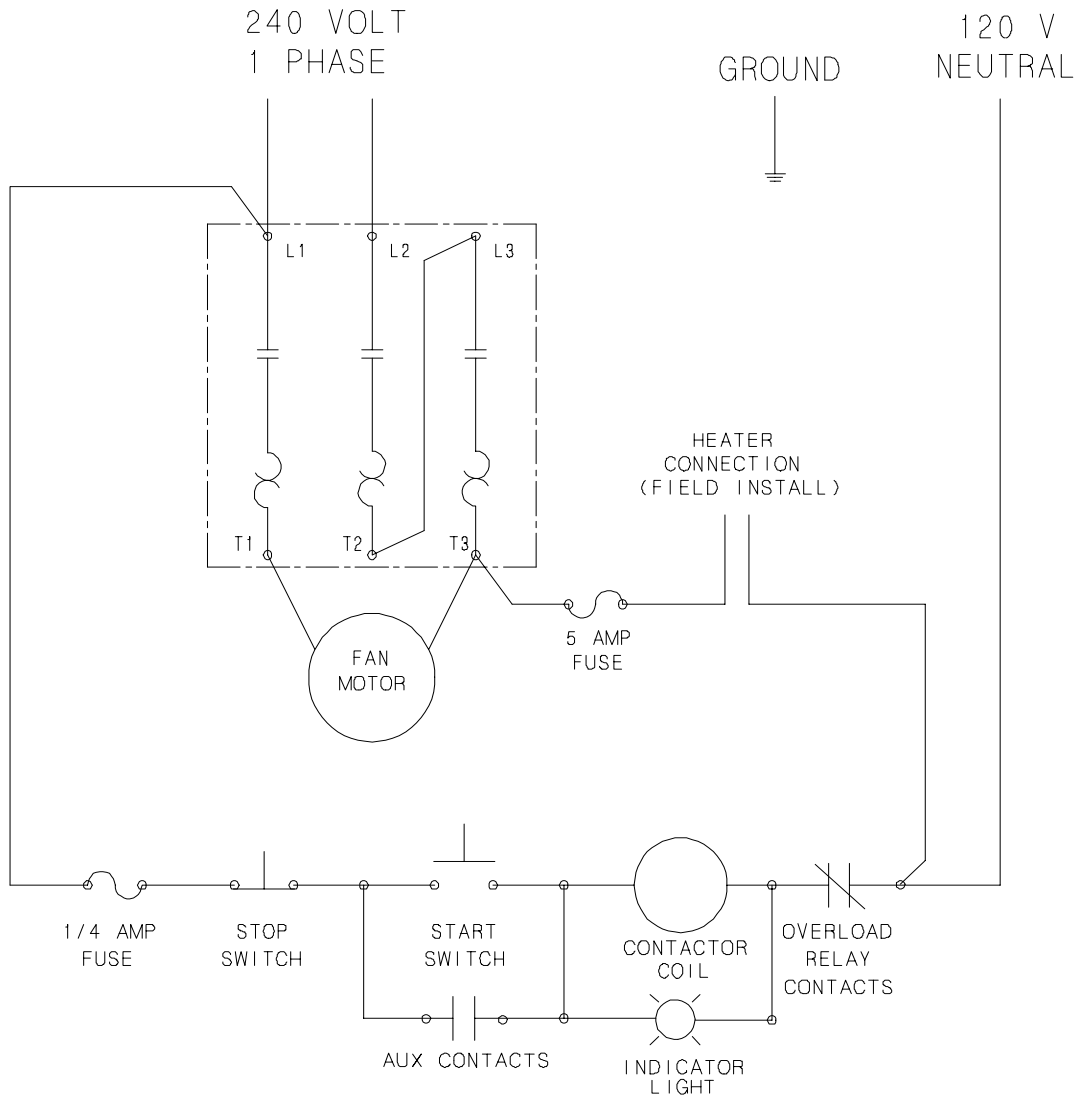

7.5, 10, 15HP 1 Phase 240 Volt Wiring Diagram and Parts

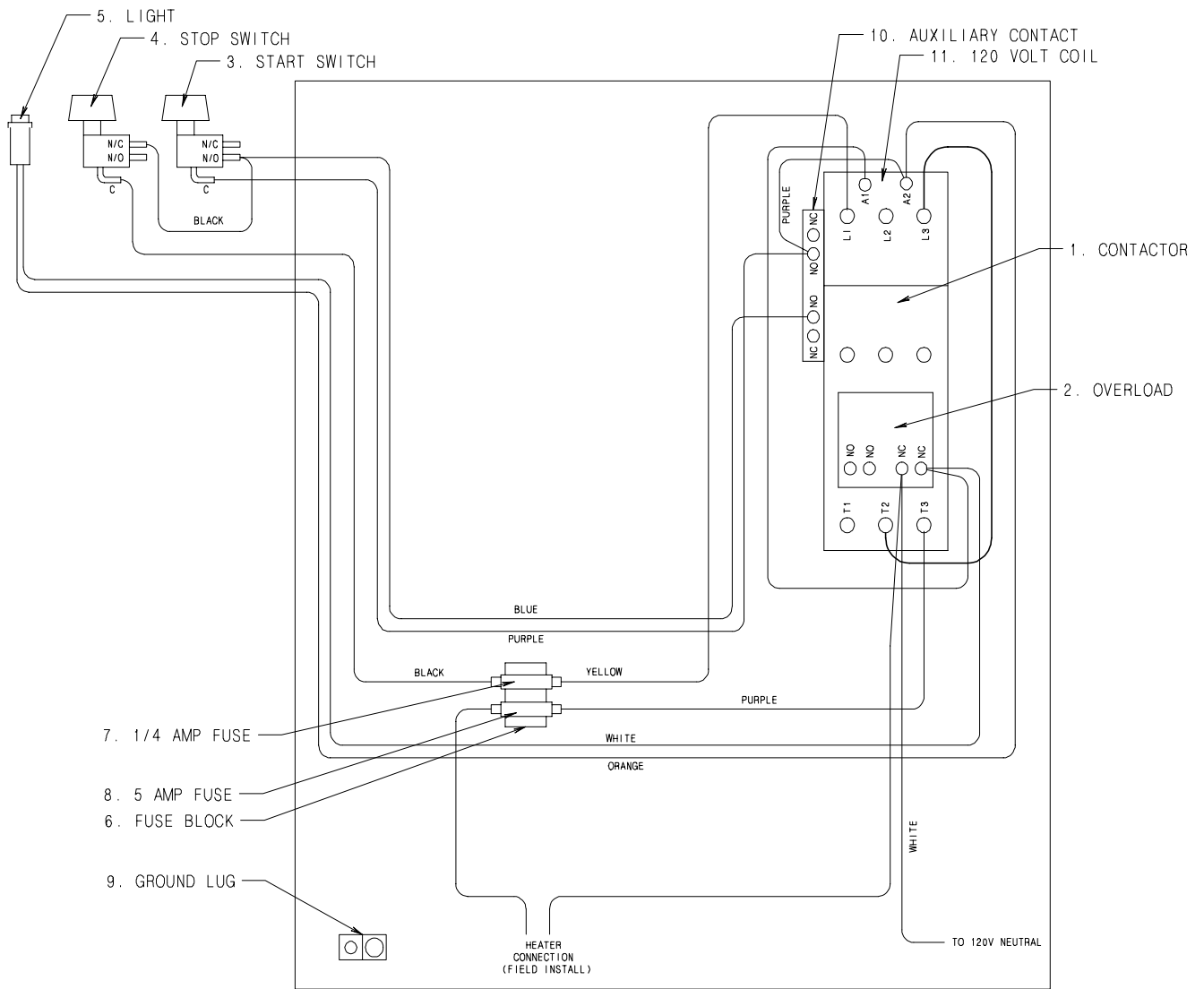

Key	Part Number			Description
	7.5 HP	10 HP	15 HP	
1	D03-0494	D03-0494	D03-0496	Contactor
2	D03-0482	D03-0483	D03-0485	Overload
3	FH-999	FH-999	FH-999	Start Switch
4	FH-1000	FH-1000	FH-1000	Stop Switch
5	TFH-2021	TFH-2021	TFH-2021	Light
6	FH-1058	FH-1058	FH-1058	Fuse Block
7	00147938	00147938	00147938	1/4 Amp Fuse
8	FH-1059	FH-1059	FH-1059	5 Amp Fuse
9	FH-6634	FH-6634	FH-6634	Ground Lug
10	D03-0511	D03-0511	D03-0511	Auxiliary Contacts
11	D03-0670	D03-0670	D03-0670	120 Volt Coil

3 Phase 240 Volt Wiring Schematic

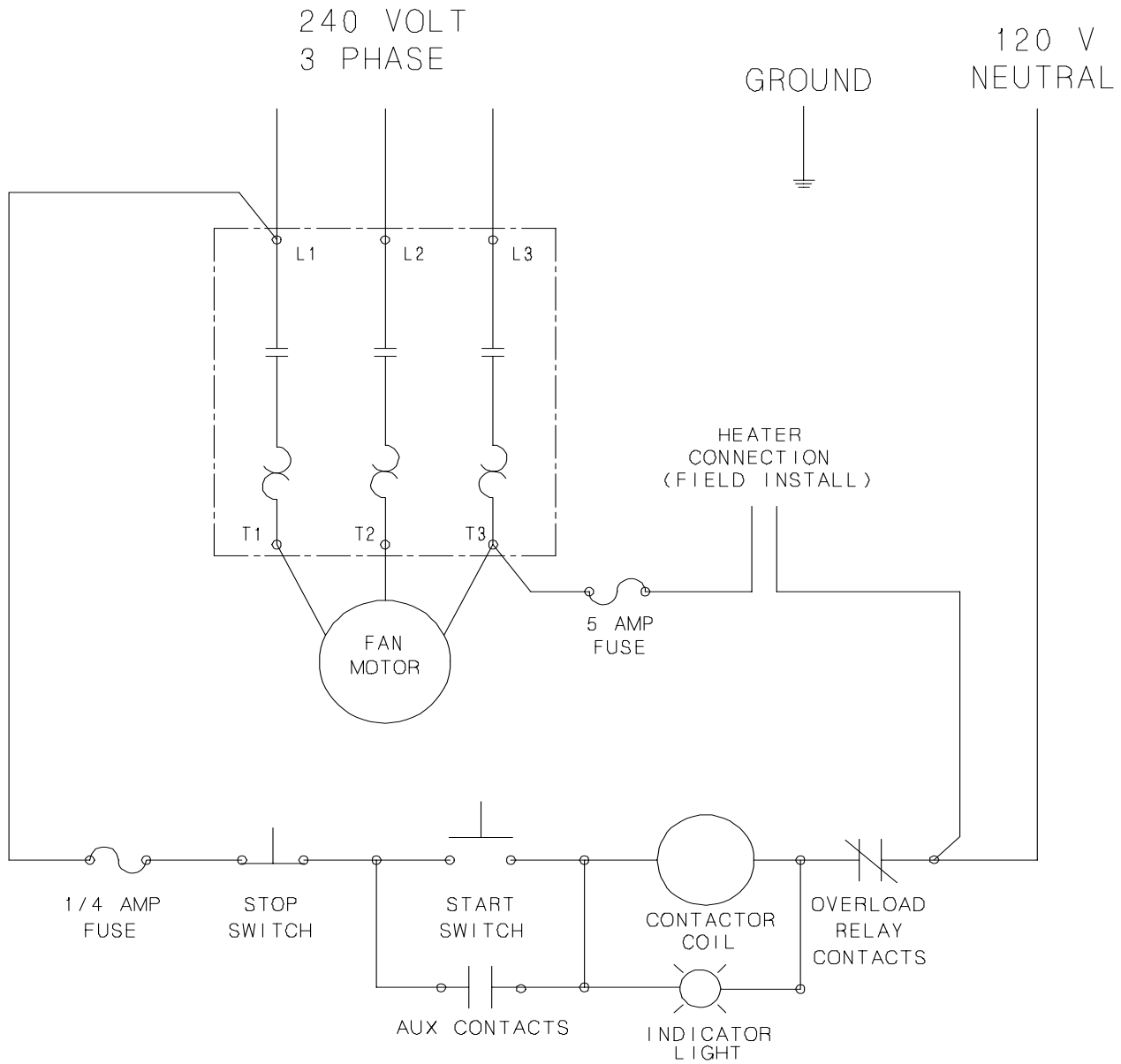

3, 5, 7.5, 10HP 240 Volt 3 Phase Wiring Diagram and Parts

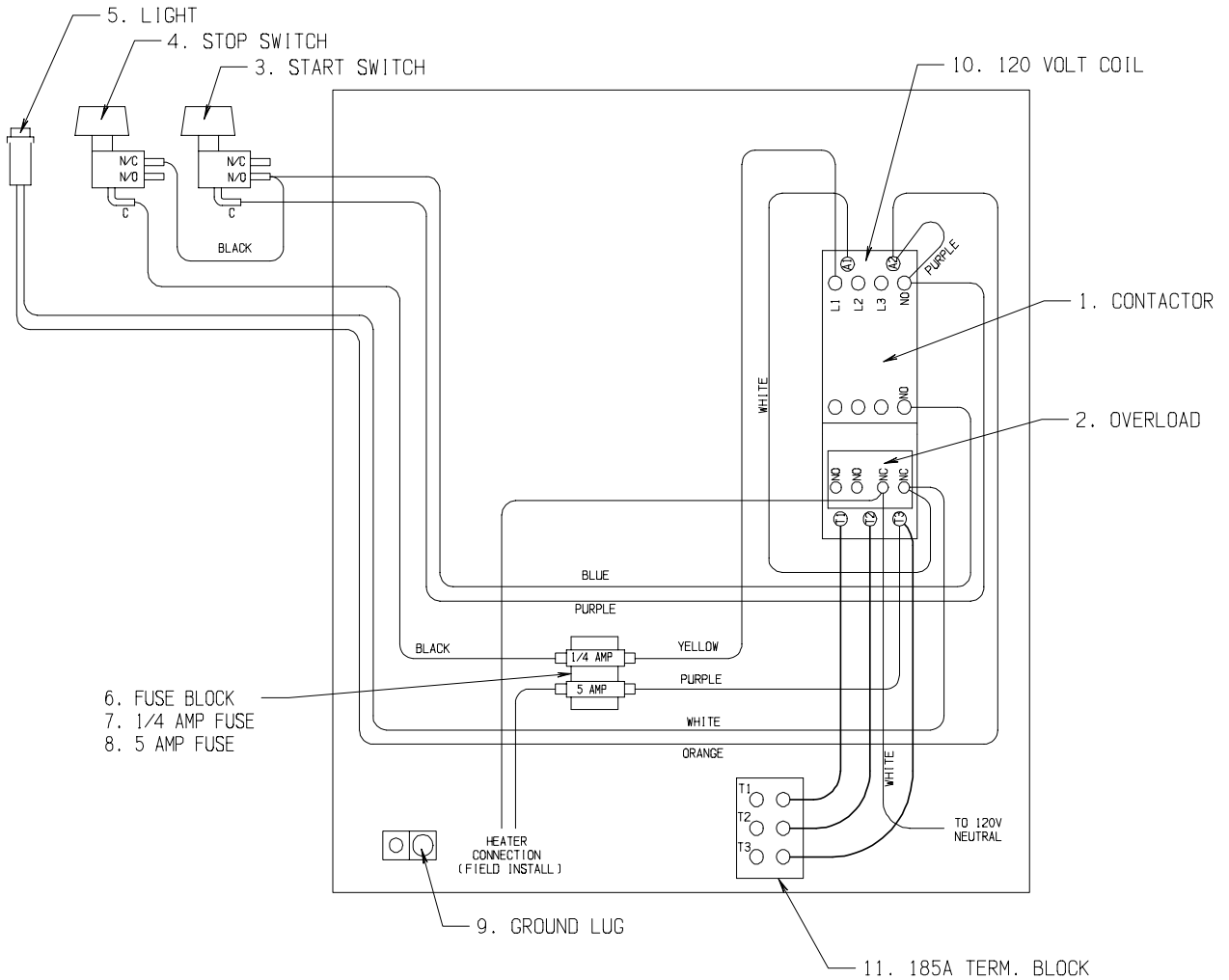

Key	Part Number				Description
	3 HP	5 HP	7.5 HP	10 HP	
1	D03-0490	D03-0490	D03-0492	D03-0492	Contactors
2	D03-0475	D03-0476	D03-0478	D03-0479	Overload
3	FH-999	FH-999	FH-999	FH-999	Start Switch
4	FH-1000	FH-1000	FH-1000	FH-1000	Stop Switch
5	TFH-2021	TFH-2021	TFH-2021	TFH-2021	Light
6	FH-1058	FH-1058	FH-1058	FH-1058	Fuse Block
7	00147938	00147938	00147938	00147938	1/4 Amp Fuse
8	FH-1059	FH-1059	FH-1059	FH-1059	5 Amp Fuse
9	FH-6634	FH-6634	FH-6634	FH-6634	Ground Lug
10	D03-0670	D03-0670	D03-0670	D03-0670	120 Volt Coil
11	C-8018	C-8018	C-8018	C-8018	185 amp Terminal Block

3 Phase 240 Volt Wiring Schematic

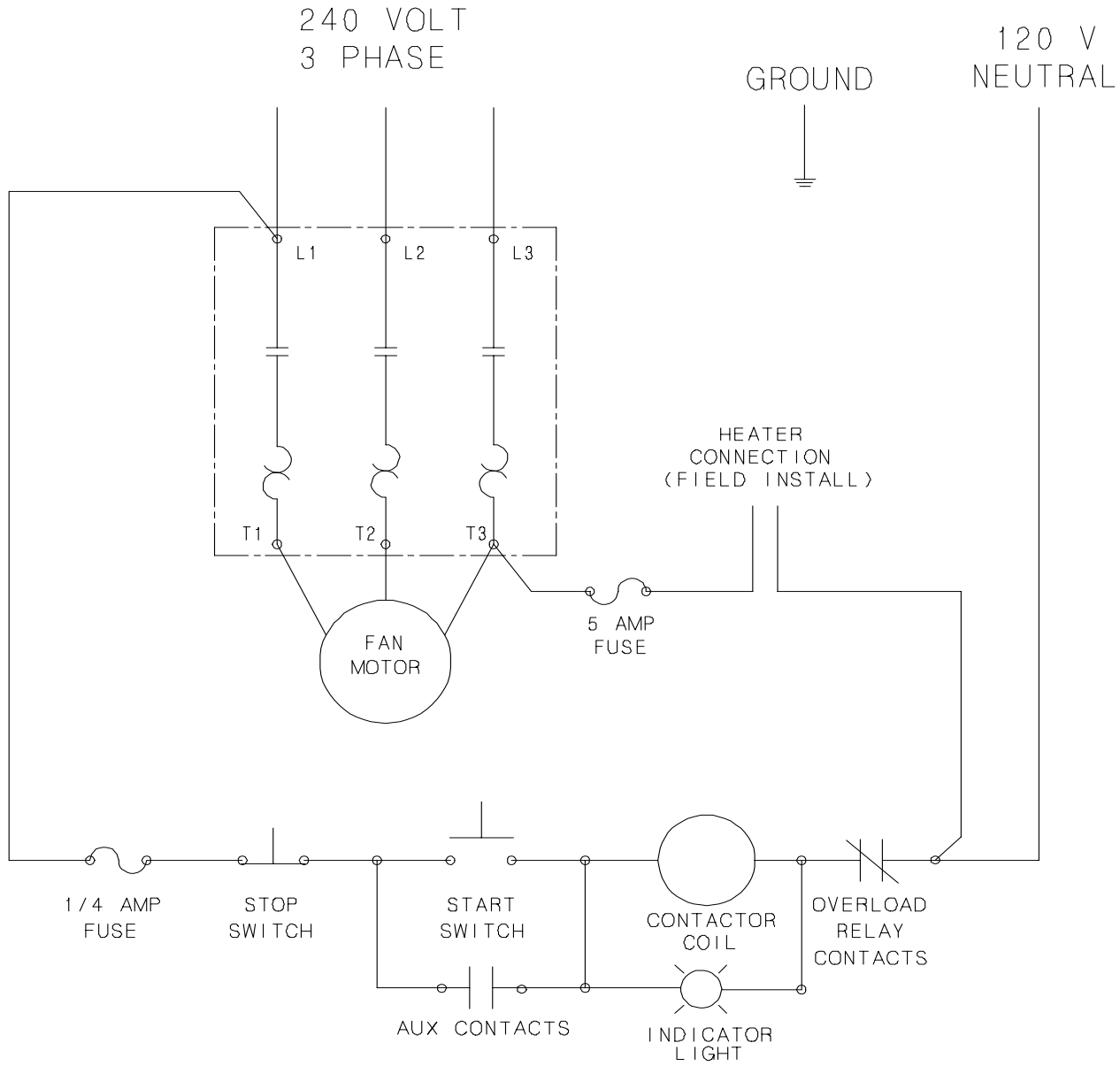

15, 20, 25, 30, 40, 50 HP 240 Volt 3 Phase Wiring Diagram and Parts

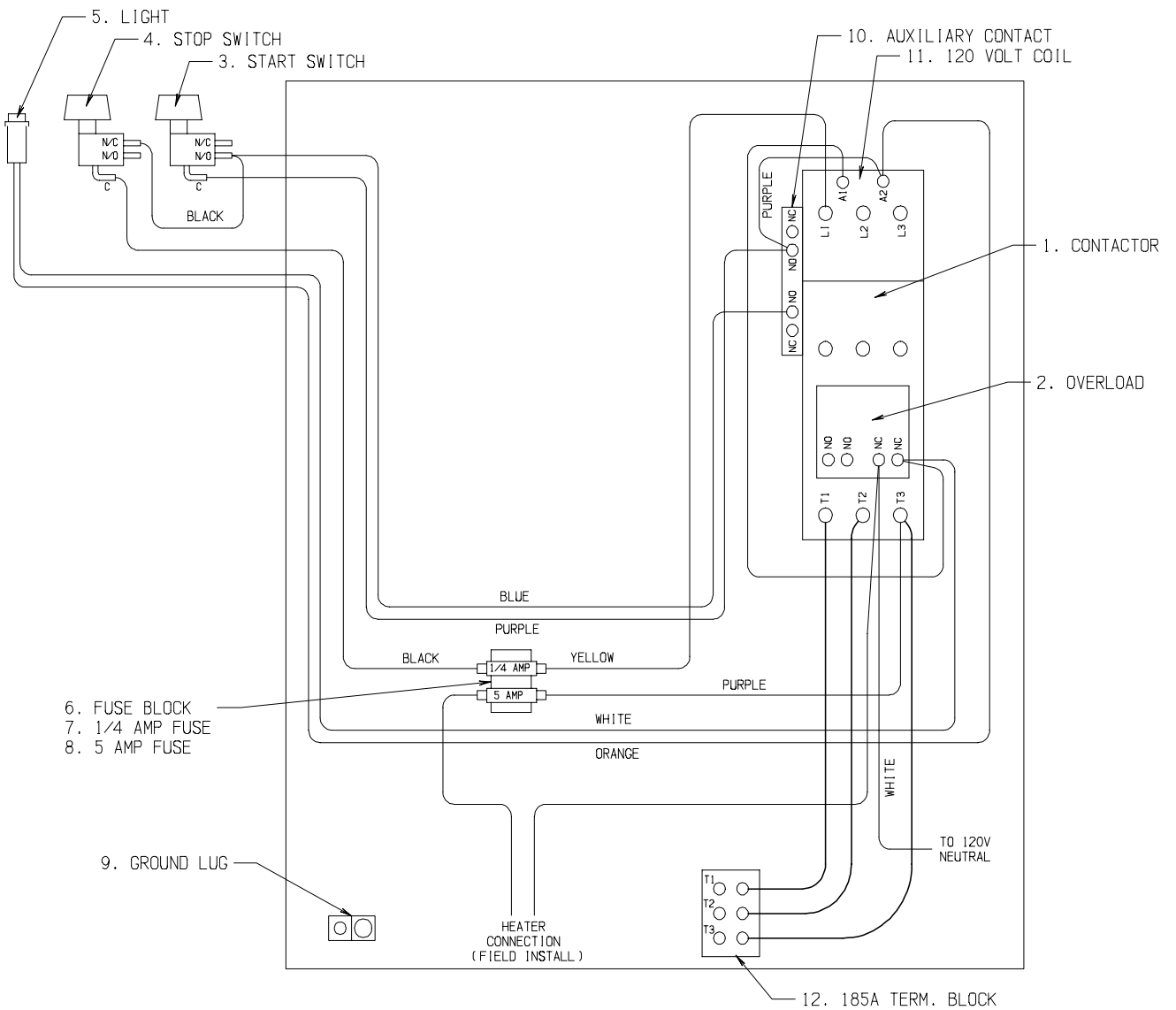

Part Number						Description
15HP	20HP	25HP	30HP	40HP	50HP	
D03-0494	D03-0495	D03-0496	D03-0497	D03-0539	D03-0539	Contactors
D03-0483	D03-0483	D03-0485	D03-0485	D03-0540	D03-0540	Overload
FH-999	FH-999	FH-999	FH-999	FH-999	FH-999	Start Switch
FH-1000	FH-1000	FH-1000	FH-1000	FH-1000	FH-1000	Stop Switch
TFH-2021	TFH-2021	TFH-2021	TFH-2021	TFH-2021	TFH-2021	Light
FH-1058	FH-1058	FH-1058	FH-1058	FH-1058	FH-1058	Fuse Block
00147938	00147938	00147938	00147938	00147938	00147938	1/4 Amp Fuse
FH-1059	FH-1059	FH-1059	FH-1059	FH-1059	FH-1059	5 Amp Fuse
FH-6634	FH-6634	FH-6634	FH-6634	FH-6634	FH-6634	Ground Lug
D03-0511	D03-0511	D03-0511	D03-0511	D03-0511	D03-0511	Auxiliary Contacts
D03-0670	D03-0670	D03-0670	D03-0670	D03-0670	D03-0670	120 Volt Coil
C-8019	C-8019	C-8019	C-8019	C-8019	C-8019	185 amp Terminal Block

3 Phase 460 Volt Schematic

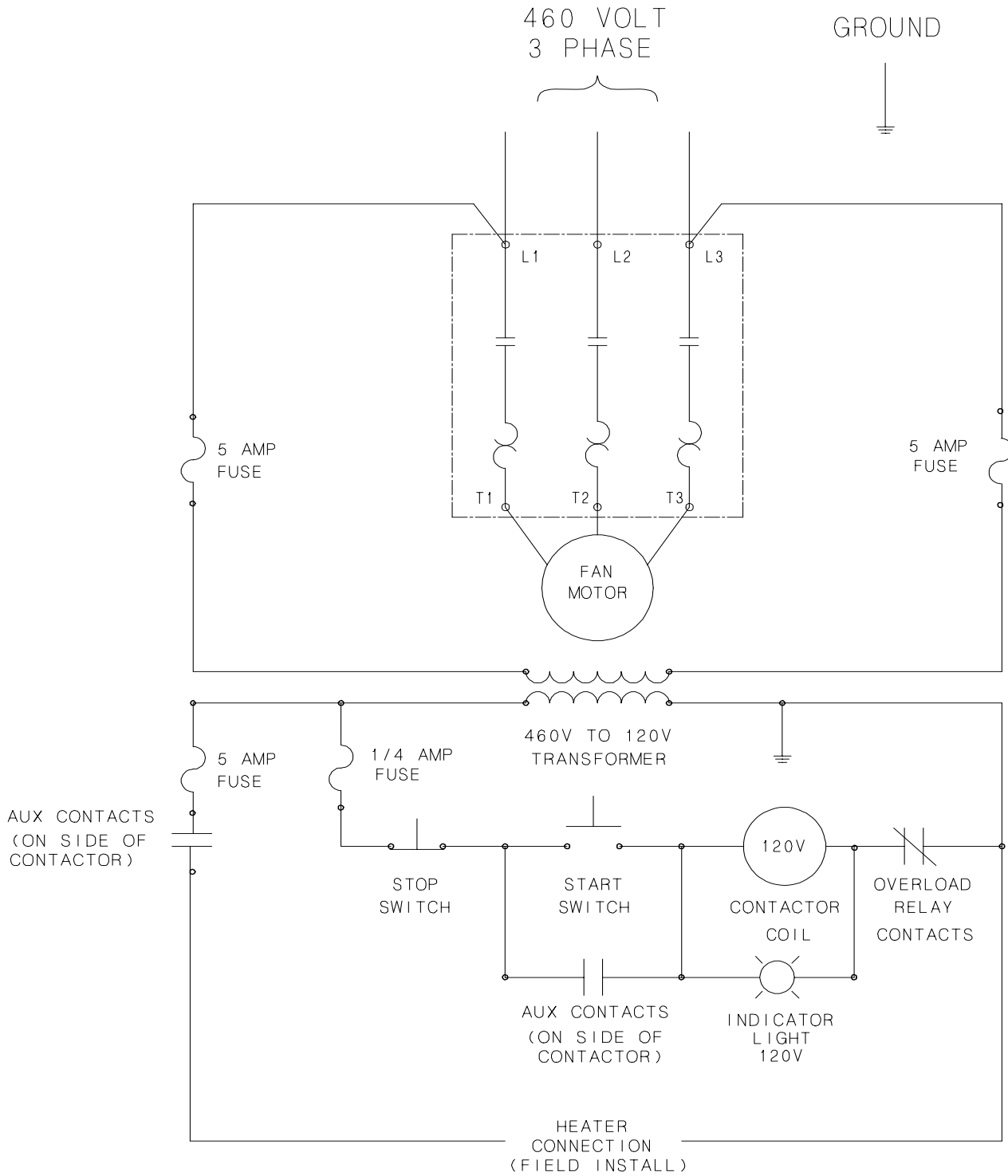

3, 5, 7.5, 10, 15, 20 HP 460 Volt 3 Phase Wiring Diagram and Parts

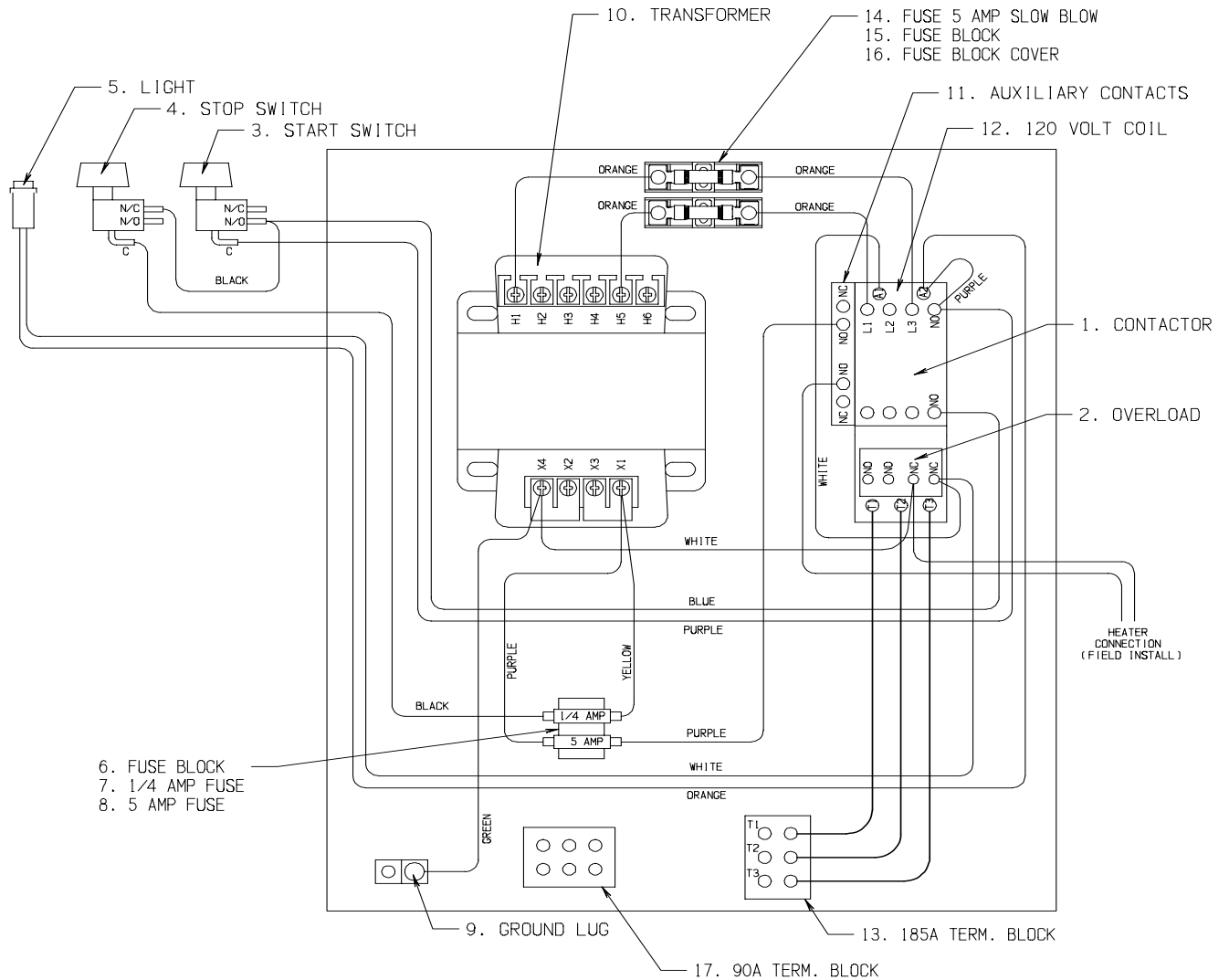

Key	Part Number						Description
	3HP	5HP	7.5HP	10HP	15HP	20HP	
1	D03-0488	D03-0488	D03-0490	D03-0490	D03-0492	D03-0492	Contactor
2	D03-0473	D03-0473	D03-0475	D03-0475	D03-0478	D03-0479	Overload
3	FH-999	FH-999	FH-999	FH-999	FH-999	FH-999	Start Switch
4	FH-1000	FH-1000	FH-1000	FH-1000	FH-1000	FH-1000	Stop Switch
5	TFH-2021	TFH-2021	TFH-2021	TFH-2021	TFH-2021	TFH-2021	Light
6	FH-1058	FH-1058	FH-1058	FH-1058	FH-1058	FH-1058	Fuse Block
7	00147938	00147938	00147938	00147938	00147938	00147938	1/4 Amp Fuse
8	FH-1059	FH-1059	FH-1059	FH-1059	FH-1059	FH-1059	5 Amp Fuse
9	FH-6634	FH-6634	FH-6634	FH-6634	FH-6634	FH-6634	Ground Lug
10	HF-7566	HF-7566	HF-7566	HF-7566	HF-7566	HF-7566	Transformer
11	D03-0511	D03-0511	D03-0511	D03-0511	D03-0511	D03-0511	Auxiliary Contacts
12	D03-0670	D03-0670	D03-0670	D03-0670	D03-0670	D03-0670	120 Volt Coil
13	C-8018	C-8018	C-8018	C-8018	C-8018	C-8018	185 amp Terminal Block
14	D36-0002	D36-0002	D36-0002	D36-0002	D36-0002	D36-0002	Slow Blow Fuse
15	D36-0003	D36-0003	D36-0003	D36-0003	D36-0003	D36-0003	Fuse Block
16	D03-0562	D03-0562	D03-0562	D03-0562	D03-0562	D03-0562	Fuse Block Cover
17	C-8021	C-8021	C-8021	C-8021	C-8021	C-8021	90 amp Terminal Block

3 Phase 460 Volt Schematic

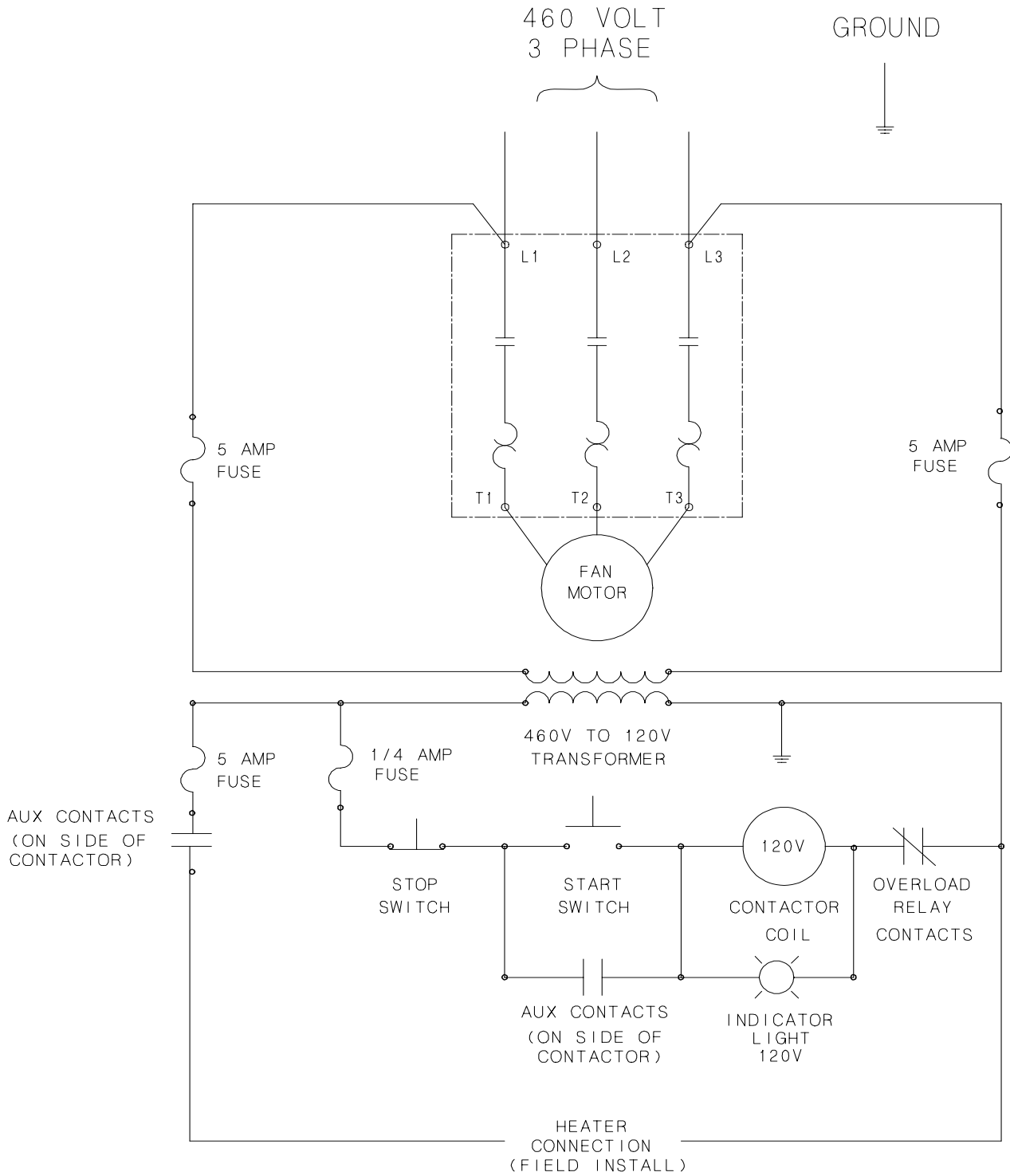

25, 30, 40, 50 HP 460 Volt 3 Phase Wiring Diagram and Parts

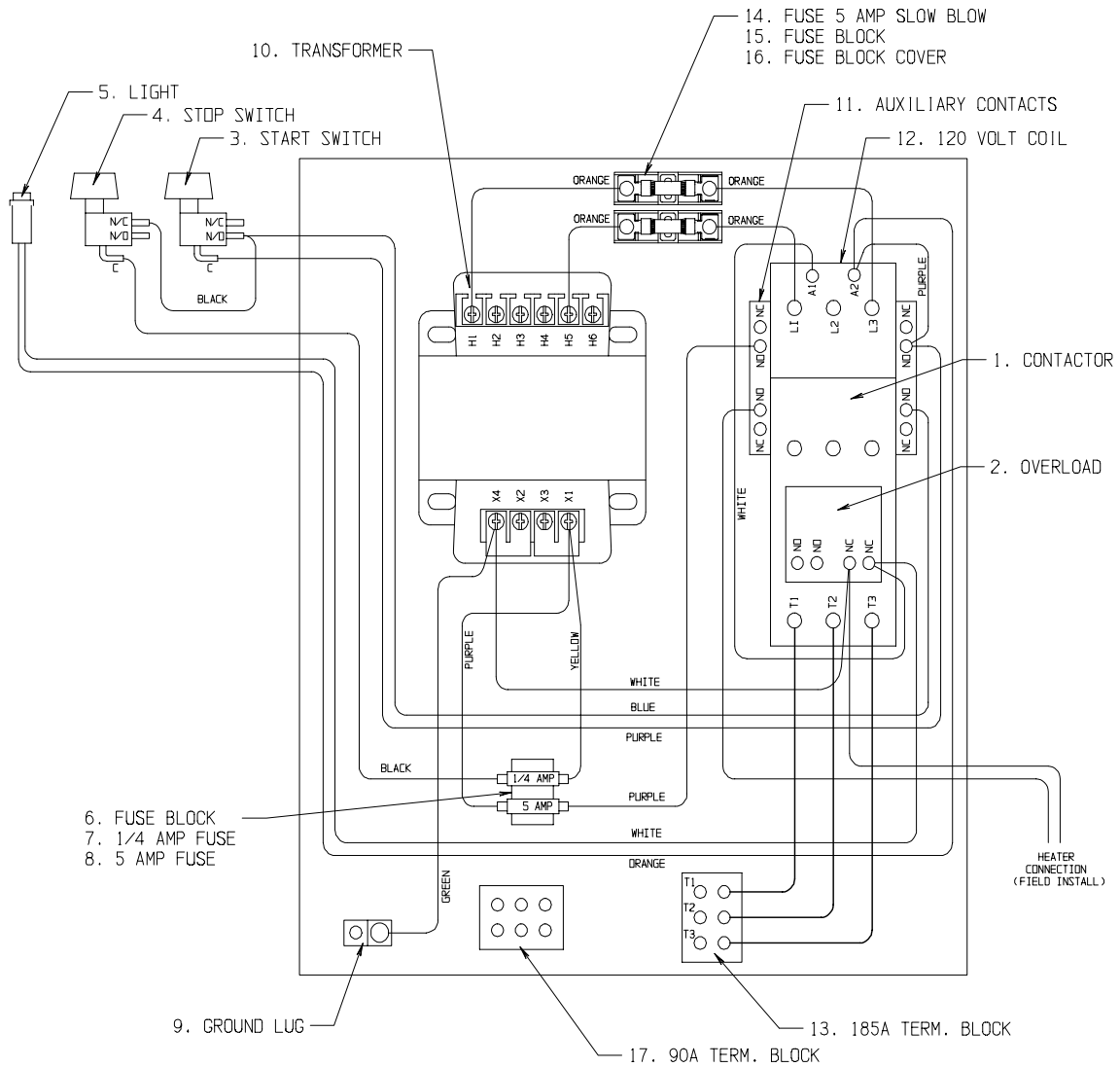

Key	Part Number				Description
	25HP	30HP	40HP	50HP	
1	D03-0493	D03-0494	D03-0495	D03-0495	Contactor
2	D03-0480	D03-0482	D03-0483	D03-0484	Overload
3	FH-999	FH-999	FH-999	FH-999	Start Switch
4	FH-1000	FH-1000	FH-1000	FH-1000	Stop Switch
5	TFH-2021	TFH-2021	TFH-2021	TFH-2021	Light
6	FH-1058	FH-1058	FH-1058	FH-1058	Fuse Block
7	00147938	00147938	00147938	00147938	1/4 Amp Fuse
8	FH-1059	FH-1059	FH-1059	FH-1059	5 Amp Fuse
9	FH-6634	FH-6634	FH-6634	FH-6634	Ground Lug
10	HF-7566	HF-7566	HF-7566	HF-7566	Transformer
11	D03-0511	D03-0511	D03-0511	D03-0511	Auxiliary Contacts
12	D03-0670	D03-0670	D03-0670	D03-0670	120 Volt Coil
13	C-8018	C-8018	C-8018	C-8018	185 amp Terminal Block
14	D36-0002	D36-0002	D36-0002	D36-0002	Slow Blow Fuse
15	D36-0003	D36-0003	D36-0003	D36-0003	Fuse Block
16	D03-0562	D03-0562	D03-0562	D03-0562	Fuse Block Cover
17	C-8021	C-8021	C-8021	C-8021	90 amp Terminal Block

3 Phase 575 Volt Schematic

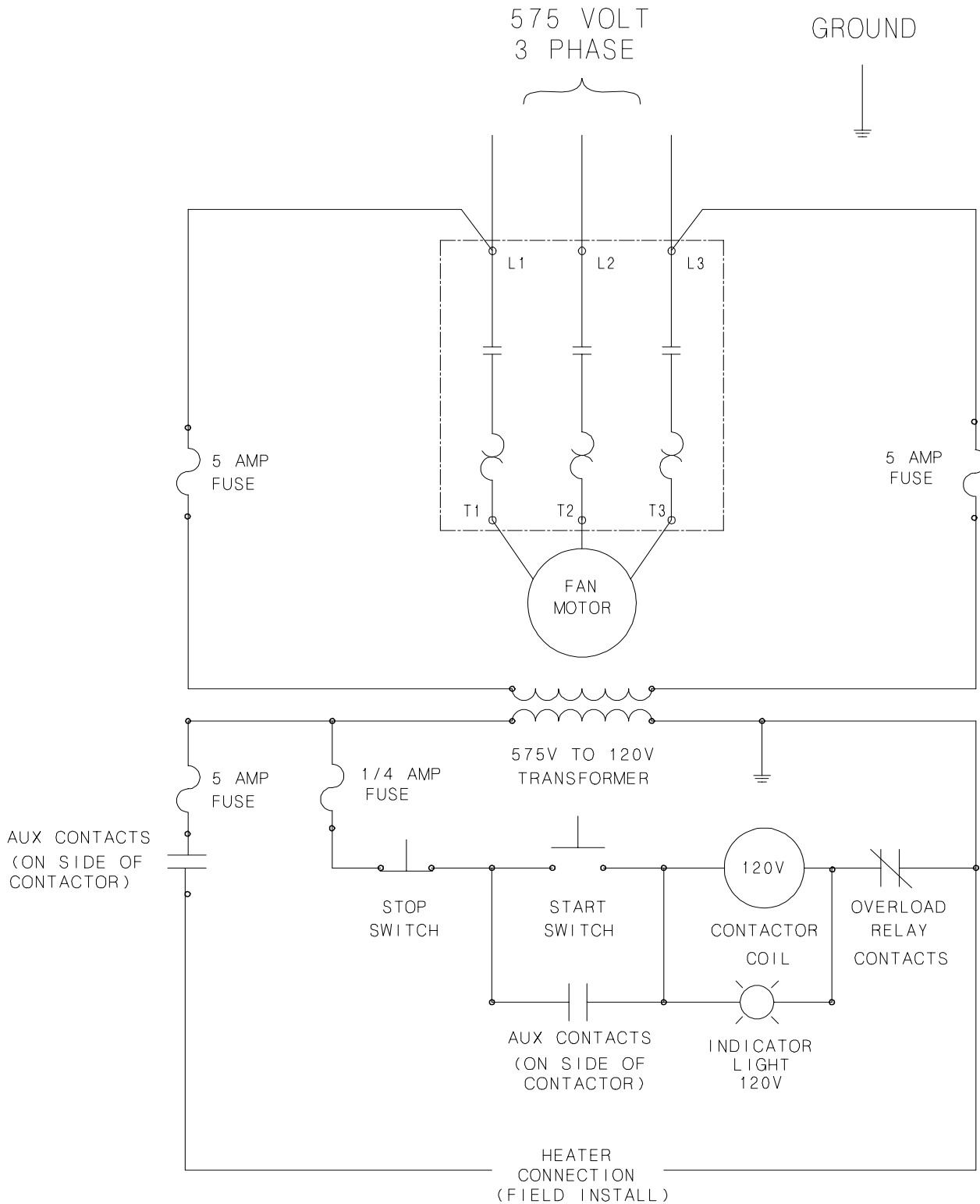

3, 5, 7.5, 10 HP 575 Volt 3 Phase Wiring Diagram and Parts

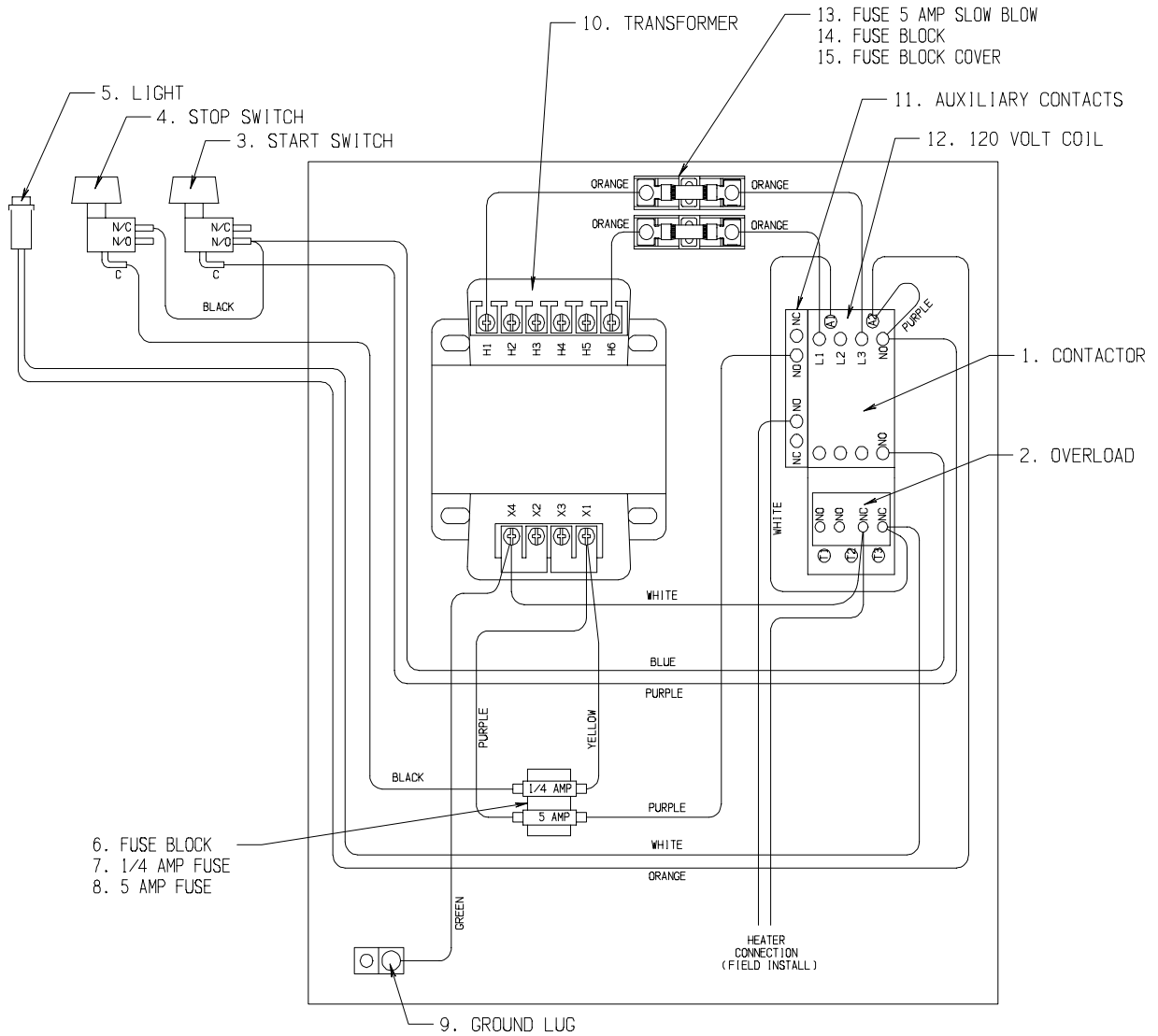

Key	Part Number				Description
	3HP	5HP	7.5HP	10HP	
1	D03-0488	D03-0488	D03-0488	D03-0489	Contactors
2	D03-0472	D03-0472	D03-0474	D03-0475	Overload
3	FH-999	FH-999	FH-999	FH-999	Start Switch
4	FH-1000	FH-1000	FH-1000	FH-1000	Stop Switch
5	TFH-2021	TFH-2021	TFH-2021	TFH-2021	Light
6	FH-1058	FH-1058	FH-1058	FH-1058	Fuse Block
7	00147938	00147938	00147938	00147938	1/4 Amp Fuse
8	FH-1059	FH-1059	FH-1059	FH-1059	5 Amp Fuse
9	FH-6634	FH-6634	FH-6634	FH-6634	Ground Lug
10	HF-7566	HF-7566	HF-7566	HF-7566	Transformer
11	D03-0511	D03-0511	D03-0511	D03-0511	Auxiliary Contacts
12	D03-0670	D03-0670	D03-0670	D03-0670	120 Volt Coil
13	D36-0002	D36-0002	D36-0002	D36-0002	Slow Blow Fuse
14	D36-0003	D36-0003	D36-0003	D36-0003	Fuse Block
15	D03-0562	D03-0562	D03-0562	D03-0562	Fuse Block Cover

3 Phase 575 Volt Schematic

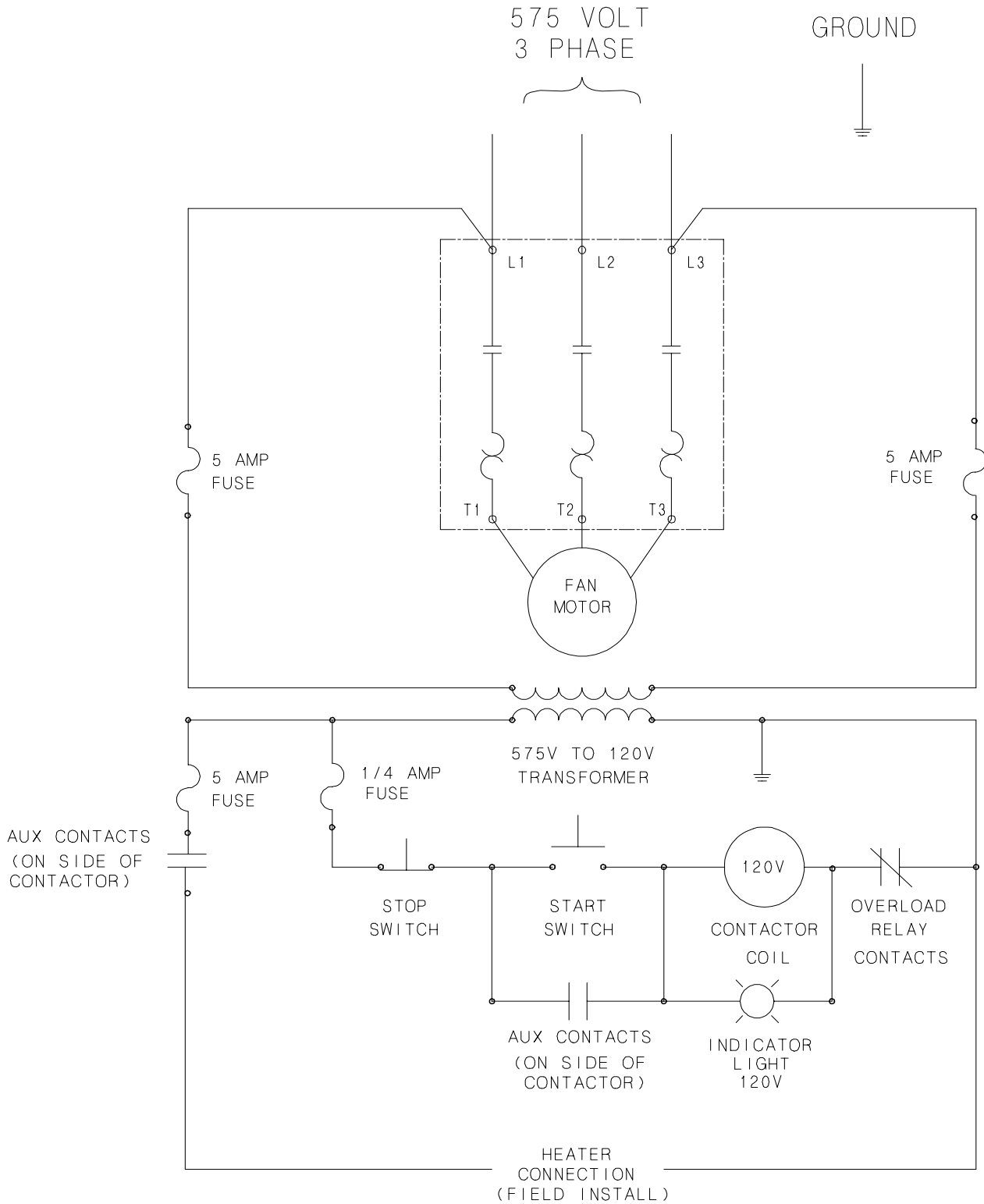

15, 20, 25, 30, 40, 50 HP 575 Volt 3 Phase Wiring Diagram and Parts

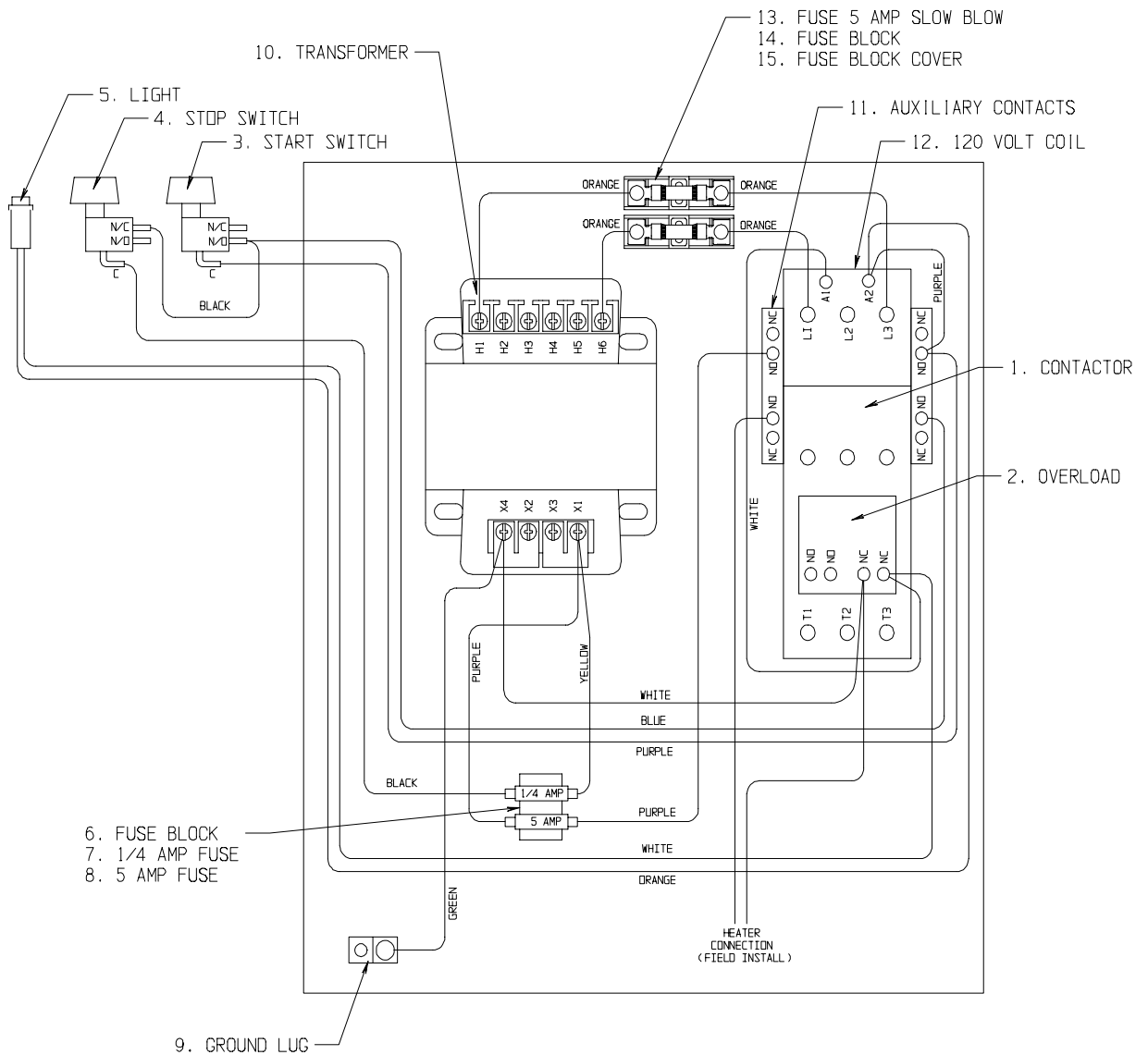

Key	Part Number						Description
	15HP	20HP	25HP	30HP	40HP	50HP	
1	D03-0491	D03-0491	D03-0493	D03-0493	D03-0494	D03-0495	Contactor
2	D03-0476	D03-0477	D03-0479	D03-0479	D03-0482	D03-0483	Overload
3	FH-999	FH-999	FH-999	FH-999	FH-999	FH-999	Start Switch
4	FH-1000	FH-1000	FH-1000	FH-1000	FH-1000	FH-1000	Stop Switch
5	TFH-2021	TFH-2021	TFH-2021	TFH-2021	TFH-2021	TFH-2021	Light
6	FH-1058	FH-1058	FH-1058	FH-1058	FH-1058	FH-1058	Fuse Block
7	00147938	00147938	00147938	00147938	00147938	00147938	1/4 Amp Fuse
8	FH-1059	FH-1059	FH-1059	FH-1059	FH-1059	FH-1059	5 Amp Fuse
9	FH-6634	FH-6634	FH-6634	FH-6634	FH-6634	FH-6634	Ground Lug
10	HF-7566	HF-7566	HF-7566	HF-7566	HF-7566	HF-7566	Transformer
11	D03-0511	D03-0511	D03-0511	D03-0511	D03-0511	D03-0511	Auxiliary Contacts
12	D03-0670	D03-0670	D03-0670	D03-0670	D03-0670	D03-0670	120 Volt Coil
13	D36-0002	D36-0002	D36-0002	D36-0002	D36-0002	D36-0002	Slow Blow Fuse
14	D36-0003	D36-0003	D36-0003	D36-0003	D36-0003	D36-0003	Fuse Block
15	D03-0562	D03-0562	D03-0562	D03-0562	D03-0562	D03-0562	Fuse Block Cover

GSI WARRANTS ALL PRODUCTS MANUFACTURED BY GSI TO BE FREE OF DEFECTS IN MATERIAL AND WORKMANSHIP UNDER NORMAL USAGE AND CONDITIONS FOR A PERIOD OF 12 MONTHS AFTER RETAIL SALE TO THE ORIGINAL END USER OF SUCH PRODUCTS. GSI'S ONLY OBLIGATION IS, AND PURCHASER'S SOLE REMEDY SHALL BE FOR GSI, TO REPAIR OR REPLACE, AT GSI'S OPTION AND EXPENSE, PRODUCTS THAT, IN GSI'S SOLE JUDGMENT, CONTAIN A MATERIAL DEFECT DUE TO MATERIALS OR WORKMANSHIP. ALL DELIVERY AND SHIPMENT CHARGES TO AND FROM GSI'S FACTORY WILL BE PURCHASER'S RESPONSIBILITY. EXPENSES INCURRED BY OR ON BEHALF OF THE PURCHASER WITHOUT PRIOR WRITTEN AUTHORIZATION FROM AN AUTHORIZED EMPLOYEE OF GSI SHALL BE THE SOLE RESPONSIBILITY OF THE PURCHASER.

EXCEPT FOR THE ABOVE STATED EXPRESS LIMITED WARRANTIES, GSI MAKES NO WARRANTY OF ANY KIND, EXPRESSED OR IMPLIED, INCLUDING, WITHOUT LIMITATION, WARRANTIES OF MERCHANTABILITY OR FITNESS FOR A PARTICULAR PURPOSE OR USE IN CONNECTION WITH (i) PRODUCT MANUFACTURED OR SOLD BY GSI OR (ii) ANY ADVICE, INSTRUCTION, RECOMMENDATION OR SUGGESTION PROVIDED BY AN AGENT, REPRESENTATIVE OR EMPLOYEE OF GSI REGARDING OR RELATED TO THE CONFIGURATION, INSTALLATION, LAYOUT, SUITABILITY FOR A PARTICULAR PURPOSE, OR DESIGN OF SUCH PRODUCT OR PRODUCTS.

IN NO EVENT SHALL GSI BE LIABLE FOR ANY DIRECT, INDIRECT, INCIDENTAL OR CONSEQUENTIAL DAMAGES, INCLUDING, WITHOUT LIMITATION, LOSS OF ANTICIPATED PROFITS OR BENEFITS. PURCHASER'S SOLE AND EXCLUSIVE REMEDY SHALL BE LIMITED TO THAT STATED ABOVE, WHICH SHALL NOT EXCEED THE AMOUNT PAID FOR THE PRODUCT PURCHASED. THIS WARRANTY IS NOT TRANSFERABLE AND APPLIES ONLY TO THE ORIGINAL PURCHASER. GSI SHALL HAVE NO OBLIGATION OR RESPONSIBILITY FOR ANY REPRESENTATIVE OR WARRANTIES MADE BY OR ON BEHALF OF ANY DEALER, AGENT OR DISTRIBUTOR OF GSI.

GSI ASSUMES NO RESPONSIBILITY FOR FIELD MODIFICATIONS OR ERECTION DEFECTS WHICH CREATE STRUCTURAL OR STORAGE QUALITY PROBLEMS. MODIFICATIONS TO THE PRODUCT NOT SPECIFICALLY COVERED BY THE CONTENTS OF THIS MANUAL WILL NULLIFY ANY PRODUCT WARRANTY THAT MIGHT HAVE BEEN OTHERWISE AVAILABLE.

THE FOREGOING WARRANTY SHALL NOT COVER PRODUCTS OR PARTS WHICH HAVE BEEN DAMAGED BY NEGLIGENT USE, MISUSE, ALTERATION OR ACCIDENT. THIS WARRANTY COVERS ONLY PRODUCTS MANUFACTURED BY GSI. THIS WARRANTY IS EXCLUSIVE AND IN LIEU OF ALL OTHER WARRANTIES EXPRESS OR IMPLIED. GSI RESERVES THE RIGHT TO MAKE DESIGN OR SPECIFICATION CHANGES AT ANY TIME.

PRIOR TO INSTALLATION, PURCHASER HAS THE RESPONSIBILITY TO RESEARCH AND COMPLY WITH ALL FEDERAL, STATE AND LOCAL CODES WHICH MAY APPLY TO THE LOCATION AND INSTALLATION.

