

# Vane Axial Heater Installation and Operation - Canadian

Model #: \_\_\_\_\_

Owner's Manual

PNEG-1775

Date: 10-10-12



Intertek



G S I G R O U P



---

## Heater Check List

1. All wire connections
2. Spark plug gap 0.125
3. Pipe train tightness and gas leaks
4. Flame sensor tight
5. Fuse in place, extra fuse provided
6. Indicator light
7. Pressure gauge
8. Regulator adjusted
9. Shut off valve operates correctly
10. Vapor high-limit
11. Unit cycles ON to OFF
12. Heat rise even across transition
13. Unit cycles high to low (high-low only)
14. All decals and serial number tag
15. Aesthetic appearance
16. Manual

Tester Signature: \_\_\_\_\_

Date: \_\_\_\_\_

## Contents

<b>Chapter 1 Introduction</b> .....	<b>4</b>
<b>Chapter 2 Safety</b> .....	<b>5</b>
Safety Guidelines .....	5
Fuel Warning .....	6
Power Warning .....	6
Proper Use of Product .....	6
Heater Operation .....	6
Safety Instructions .....	7
<b>Chapter 3 Safety Decals</b> .....	<b>9</b>
Roof Damage Warning and Disclaimer .....	9
Heater Access Door Decals .....	10
Control Box Decals .....	11
<b>Chapter 4 Specifications</b> .....	<b>12</b>
Heater Specifications .....	12
<b>Chapter 5 Installation</b> .....	<b>13</b>
Machine to Earth Ground .....	13
Previously Installed Units .....	13
Fuel Connection .....	13
Liquid Propane Models .....	13
Propane Vapor Models .....	13
Natural Gas Models .....	13
CSA Heater Electrical Installation .....	14
Standard Heater - Second Heater Installation .....	15
Bin Configuration .....	16
Plenum Thermostat Transition High-Limit Installation .....	16
Plenum Thermostat Mounting .....	17
Heater Orifice Setup .....	18
<b>Chapter 6 Operation</b> .....	<b>19</b>
Operating Temperature Table .....	19
Cycling Heater Operation .....	19
High-Low Heater Operation .....	20
Adjusting the Vaporizer .....	21
BTUs for Gauge Pressure (PSI) Reading Propane Models (Approximate) .....	22
BTUs for Gauge Pressure (PSI) Reading Natural Gas Models (Approximate) .....	23
<b>Chapter 7 Service</b> .....	<b>24</b>
<b>Chapter 8 Troubleshooting - Heater</b> .....	<b>25</b>
<b>Chapter 9 Wiring Diagrams</b> .....	<b>26</b>
Heater Wiring .....	26
Standard Heater Schematic .....	27
<b>Chapter 10 Parts List</b> .....	<b>29</b>
CSA Heater Control Box Assembly (HF-8184) .....	30
18", 24" and 28" Gas Heater Parts .....	32
18" Vapor/NG Pipe Train Assembly .....	34
24" and 28" LP Pipe Train Assembly .....	35
24" and 28" LP High-Low Pipe Train Assembly .....	36
24" and 28" Propane Vapor Pipe Train Assembly .....	37
24" and 28" Propane Vapor High-Low Pipe Train Assembly .....	38
24" and 28" Vapor/NG High-Low Pipe Train Assembly .....	39
LP Supply Pipe Train Assembly .....	40
<b>Chapter 11 Warranty</b> .....	<b>41</b>

## 1. Introduction

---

Thank you for choosing a GSI product. It is designed to give excellent performance and service for many years.

This manual describes the operation of the CSA Vane Axial Heater. It is designed for low to medium temperature grain conditioning and is ideal for the aeration of rice, popcorn or other select grains. It is available in both propane vapor and natural gas models.

Our foremost concern is your safety and the safety of others associated with this equipment. We want to keep you as a customer. This manual is to help you understand safe operating procedures and some problems which may be encountered by the operator and other personnel.

As owner and/or operator, it is your responsibility to know what requirements, hazards and precautions exist and to inform all personnel associated with the equipment or in the area. Safety precautions may be required from the personnel. Avoid any alterations to the equipment. Such alterations may produce a very dangerous situation where **SERIOUS INJURY** or **DEATH** may occur.

This equipment shall be installed in accordance with the current installation codes and applicable regulations which should be carefully followed in all cases. Authorities having jurisdiction should be consulted before installations are made.

## Safety Guidelines

This manual contains information that is important for you, the owner/operator, to know and understand. This information relates to protecting **personal safety** and **preventing equipment problems**. It is the responsibility of the owner/operator to inform anyone operating or working in the area of this equipment of these safety guidelines. To help you recognize this information, we use the symbols that are defined below. Please read the manual and pay attention to these sections. Failure to read this manual and its safety instructions is a misuse of the equipment and may lead to serious injury or death.



**This is the safety alert symbol. It is used to alert you to potential personal injury hazards. Obey all safety messages that follow this symbol to avoid possible injury or death.**



**DANGER** indicates a hazardous situation which, if not avoided, will result in death or serious injury.



**WARNING** indicates a hazardous situation which, if not avoided, could result in death or serious injury.



**CAUTION**, used with the safety alert symbol, indicates a hazardous situation which, if not avoided, could result in minor or moderate injury.



**NOTICE** is used to address practices not related to personal injury.

### Fuel Warning



*Do not use propane tanks which have previously been used for ammonia unless they have been purged according to procedures of the National LP Association.*

*Be sure fuel supply system complies with all local codes for LP gas installations.  
DO NOT USE FLAME FOR LEAK TESTING.*

### Power Warning

Be sure power is disconnected and locked out before installation. Failure to do so may cause serious injury or death.

**IMPORTANT:** *Heater must be interlocked with fan for safe operation.*

**IMPORTANT:** *Thermostat must be installed for safe operation.*

### Proper Use of Product

This product is intended for the use of grain drying only. Any other use is a misuse of this product. This product has sharp edges. These sharp edges may cause serious injury. To avoid injury handle sharp edges with caution and use proper protective clothing and equipment at all times. Guards are removed for illustration only. All guards must be in place before and during operation.

### Heater Operation

Thank you for choosing a GSI product. It is designed to give excellent performance and service for many years.

This manual describes the operation of the GSI CSA Vane Axial Heater. Many models are available to accommodate low, medium or high temperature grain conditioning.

## Safety Instructions

Our foremost concern is your safety and the safety of others associated with this equipment. We want to keep you as a customer. This manual is to help you understand safe operating procedures and some problems that may be encountered by the operator and other personnel.

As owner and/or operator, it is your responsibility to know what requirements, hazards, and precautions exist, and to inform all personnel associated with the equipment or in the area. Safety precautions may be required from the personnel. Avoid any alterations to the equipment. Such alterations may produce a very dangerous situation where **SERIOUS INJURY** or **DEATH** may occur.

This equipment shall be installed in accordance with the current installation codes and applicable regulations, which should be carefully followed in all cases. Authorities having jurisdiction should be consulted before installations are made.

### Follow Safety Instructions

Carefully read all safety messages in this manual and safety signs on your machine. Keep signs in good condition. Replace missing or damaged safety signs. Be sure new equipment components and repair parts include the current safety signs. Replacement safety signs are available from the manufacturer.

Learn how to operate the machine and how to use controls properly. Do not let anyone operate without instruction.

Keep your machinery in proper working condition. Unauthorized modifications to the machine may impair the function and/or safety and affect machine life.

If you do not understand any part of this manual or need assistance, contact your dealer.

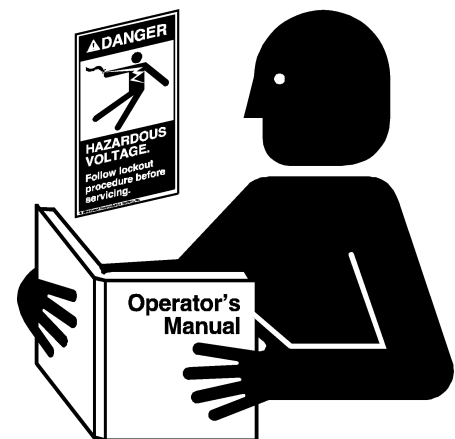

**Read and Understand Manual**

### Install and Operate Electrical Equipment Properly

Electrical controls should be installed by a qualified electrician and must meet the standards set by the National Electrical Code and all local and state codes.

Disconnect and lock out all power sources before installing wires/cables or servicing equipment.



**Electric Shock Hazard**

## 2. Safety

### Install and Operate Gas-Fired Equipment Properly

Fuel supply should be installed by a qualified gas technician and must meet local and state codes for gaseous fuel supplies.

Disconnect and lock out all fuel sources before servicing equipment.



### Prepare for Emergencies

Be prepared if fire starts.

Keep a first aid kit and fire extinguisher handy.

Keep emergency numbers for doctors, ambulance service, hospital and fire department near your telephone.

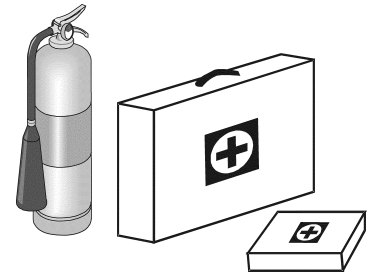

**Keep Emergency Equipment Quickly Accessible**

### Wear Protective Clothing

Wear close-fitting clothing and safety equipment appropriate to the job.

Remove all jewelry.

Tie long hair up and back.

Wear safety glasses at all times to protect eyes from debris.

Wear gloves to protect your hands from sharp edges on plastic or steel parts.

Wear steel-toed boots to help protect your feet from falling debris. Tuck in any loose or dangling shoestrings.

A respirator may be needed to prevent breathing potentially toxic fumes and dust.

Wear a hard hat to help protect your head.

Wear appropriate fall protection equipment when working at elevations greater than six feet (6').

**Eye Protection**

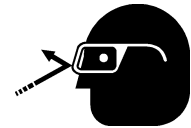

**Gloves**



**Steel-Toed Boots**



**Respirator**



**Hard Hat**



**Fall Protection**





If a decal is damaged or missing, contact:

**GSI Decals**

1004 E. Illinois St.  
Assumption, IL. 62510  
Phone: 1-217-226-4421

A free replacement will be sent to you.

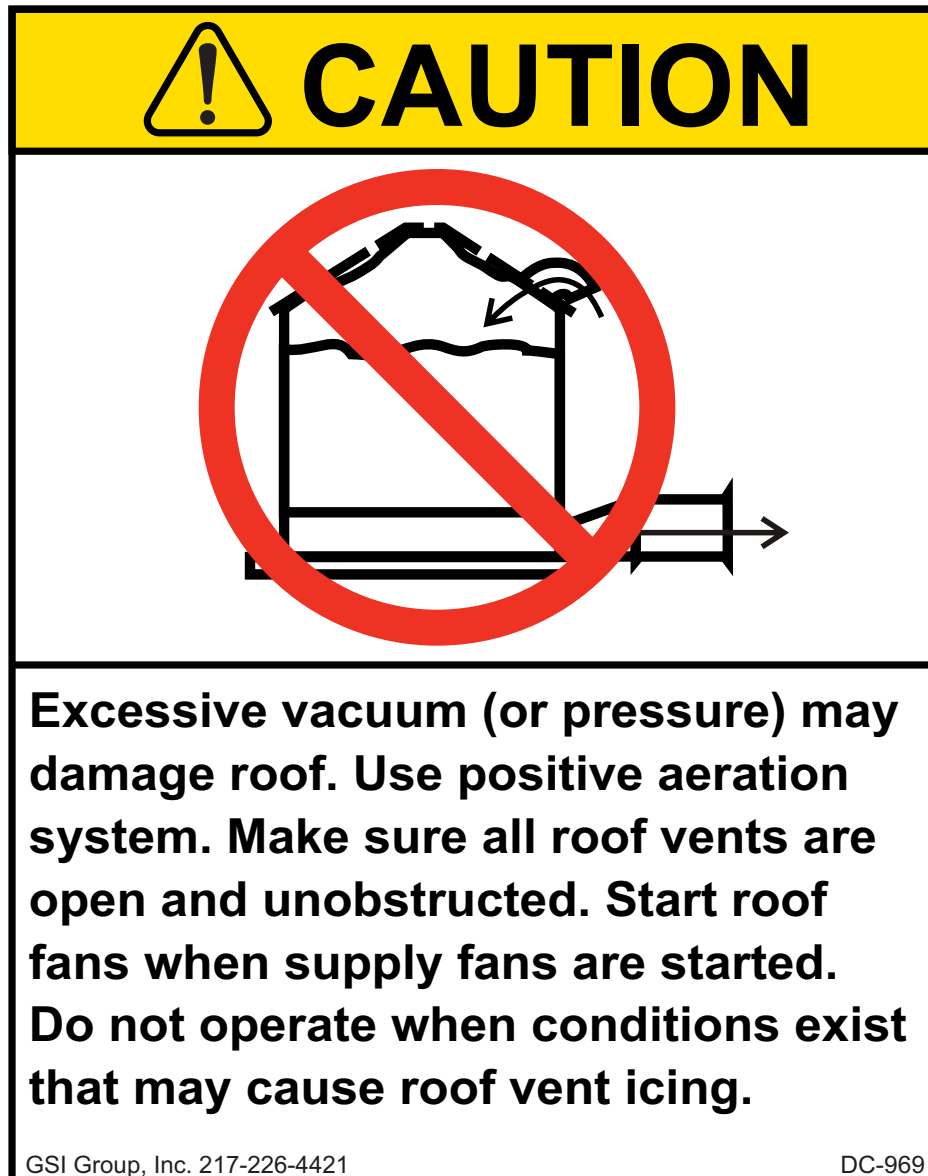

## Roof Damage Warning and Disclaimer

The manufacturer does not warrant any roof damage caused by excessive vacuum or internal pressure from fans or other air moving systems. Adequate ventilation and/or “makeup air” devices should be provided for all powered air handling systems. The manufacturer does not recommend the use of downward flow systems (suction). Severe roof damage can result from any blockage of air passages. Running fans during high humidity/cold weather conditions can cause air exhaust or intake ports to freeze.



### 3. Safety Decals

## Heater Access Door Decals

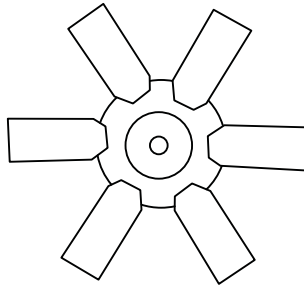
<p><b>⚠ WARNING</b></p> <p>Stay clear of rotating blade. Blade could start automatically. Can cause serious injury. Disconnect power before servicing.</p> <p>GSI Group Inc. 217-226-4421</p>		<p><b>⚠ AVERTISSEMENT</b></p> <p>Restez éloigné de la lame tournante. La lame peut se mettre en marche automatiquement. Peut causer de sérieuses blessures. Vérifiez le courant avant l'entretien.</p> <p>DC-1949</p>	<p><b>DC-1949</b></p> <p>Size: 4-7/8" x 3" Located above access door on heater housing.</p>
<p><b>⚠ WARNING</b></p> <p>Flame and pressure beyond door can cause serious injury. Do not operate with service door removed. Keep head and hands clear.</p> <p>GSI Group Inc. 217-226-4421</p>		<p><b>⚠ AVERTISSEMENT</b></p> <p>La flamme et la pression au-delà de la porte peuvent causer des dommages sérieux. Ne pas faire fonctionner si la porte de service est enlevée. Gardez les mains et la tête éloignés.</p> <p>DC-1959</p>	<p><b>DC-1959</b></p> <p>Size: 4-7/8" x 3" Located above access door on heater housing.</p>
<p>AIRFLOW →</p> <p>← AIRFLOW</p>		<p>→ CIRCULATION D'AIR</p> <p>← CIRCULATION D'AIR</p> <p>DC-1971</p>	<p><b>DC-1971</b></p> <p>Size: 4-3/4" x 1-5/8" Located above access door on heater housing.</p>

Control Box Decals

**DANGER**  
**HIGH VOLTAGE**  
 Will cause serious injury or death.  
 Lockout power before servicing.

GSI Group 217-226-4421



**DANGER**  
**HAUTE TENSION**  
 Causera de sérieuses blessures ou la mort.  
 Couper/verrouiller le courant avant l'entretien.

DC-1948

DC-1948

Size: 4-3/8" x 1-3/8"  
 Located in control box on side opposite switches.

**DANGER**  
**HIGH VOLTAGE**  
 Will cause injury or death.  
 Lockout power before servicing.  
**HAUTE TENSION**  
 Causera des blessures ou la mort.  
 Fermez le courant avant l'entretien.

Remove plug to reset high limit.  
 Enlevez le contact pour reinitialiser la limite élevée.

DC-1165

DC-1165

← →

**WARMER**                      **COLDER**  
**PLUS CHAUD**                      **PLUS FROID**

**VAPORIZER ADJUSTMENT**  
**AJUSTEMENT DU VAPORISATEUR**

Vaporizer coil should be adjusted so that vapor pipe train is warm (100-125 degrees F) to the touch.  
 La bobine du vaporisateur devrait être ajustée pour que la vapeur du conduit de transmission soit chaude au toucher (100-125 degrés F°).

DC-535

DC-535

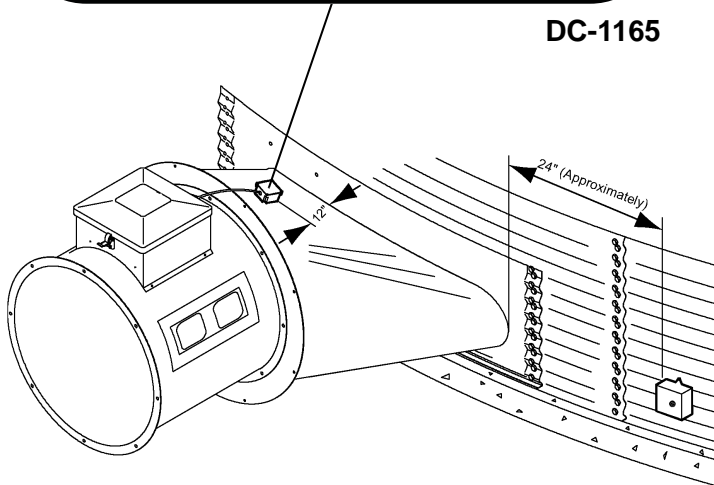

**NOTICE**

Thermostat must be installed for operation.

Failure to do so may damage equipment and cause fire.



**NOTICE**

Le thermostat doit être installé pour fonctionner.

Omettre cette installation peut endommager l'équipement et provoquer un feu.

DC-1702

DC-1702

Size: 5.825" x 1-1/2"

## 4. Specifications

### Heater Specifications

		18"	24"	28"
All Models	Inside Diameter	18-5/16"	24-1/4"	28-1/8"
	Bole Circle Diameter	19-7/16"	25-3/4"	29-5/8"
	Length	22"	22-1/2"	25-1/4"
	High Temp BTU Rating	1,400,000	2,100,000	3,000,000
	Low Temp BTU Rating	400,000	500,000	500,000
High Temperature Liquid Propane	Maximum Fuel Flow (GPH)	N/A	23	34
	Orifice	N/A	15/64	9/32
	Operating Pressure Range	N/A	2-20	2-20
	Min Line Size	N/A	3/8"	3/8"
High Temperature Natural Gas	Maximum Fuel Flow (CFH)	1473	2210	3157
	Orifice	17/64	5/16	3/8
	Operating Pressure Range	1-7	1-7	1-7
	Min Line Size	1"	1-1/4"	1-1/4"
Low Temperature Liquid Propane	Maximum Fuel Flow (GPH)	N/A	6	6
	Orifice	N/A	5/32	5/32
	Operating Pressure Range	N/A	2-20	2-20
	Min Line Size	N/A	1/4"	1/4"
Low Temperature Natural Gas	Maximum Fuel Flow (CFH)	421	736	736
	Orifice	9/64	3/32	3/32
	Operating Pressure Range	1-7	1-7	1-7
	Min Line Size	1/2"	1/2"	1/2"

## Machine to Earth Ground

It is very important that a machine to earth ground rod be installed at the fan. This is true even if there is a ground at the pole 15' away. This ground needs to be as close to the fan as possible, but no more than 8' away. The ground rod should be connected to the fan control panel with at least a #6 solid bare copper ground wire, or in accordance with local requirements. The machine to earth ground provides additional safety if there is a short. It also provides the grounding necessary for long life and operation of the solid state circuit boards used on control circuits and the electronic ignition systems.

## Previously Installed Units

It is recommended that previously installed units be checked to see that a machine to earth ground has been installed by an electrician.

## Fuel Connection



***Do not use propane tanks which have previously been used for ammonia unless they have been purged according to procedures of the national LP association.***

***Investigate to be sure that the fuel supply system complies with all local codes for LP gas installations.***

## Liquid Propane Models

1. LP models are designed to run on liquid propane, with liquid draw from the propane tank. Avoid using propane supply tanks that have been use for vapor draw for long periods of time. When using liquid draw systems any moisture that may be present in tank or lines may freeze when system is used in cold weather. To avoid this, the usual precaution is to purge the system with methanol.
2. Run proper size line ([See Specifications on Page 12](#)) to pipe train on heater. Have a qualified gas service person inspect installation to be sure everything is installed according to local codes and ordinances.
3. After installation is complete check all connections for leaks. Use liquid detergent or comparable substance. Wear rubber gloves and eye protection. Avoid contact with liquid propane. **DO NOT USE FLAME FOR LEAK TESTING.**

## Propane Vapor Models

1. Propane vapor models are designed to run directly off of supply tank or from a separate external vaporizer.
2. Run proper size line ([See Specifications on Page 12](#)) to pipe train on heater. Have a qualified gas service person inspect installation to be sure everything is installed according to local codes and ordinances.
3. After installation is complete check all connections for leaks.

## Natural Gas Models

1. Natural gas models are similar to vapor models, but have a larger orifice to accommodate lower pressure, sometimes found with natural gas.
2. Run proper size line ([See Specifications on Page 12](#)) to pipe train on heater. Have a qualified gas service person inspect installation to be sure everything is installed according to local codes and ordinances.
3. After installation is complete check all connections for leaks.

## 5. Installation

### CSA Heater Electrical Installation



**Always disconnect and lock out power before working on or around heater.**

Standard electrical safety practices and codes should be used when working with a heater. Refer to the National Electric Code Standard Handbook by the National Fire Protection Association. A *qualified electrician* should make all wiring installations.

**IMPORTANT:** Heater must be interlocked with fan for safe operation.

#### Heater Power Connection

1. Connect power cord to fan control box.
2. Make field connections in fan box as shown in [Figure 5A](#).
3. Connect deluxe thermostat control as shown in [Figure 5A](#).

**IMPORTANT:** Thermostat must be installed for safe operation.

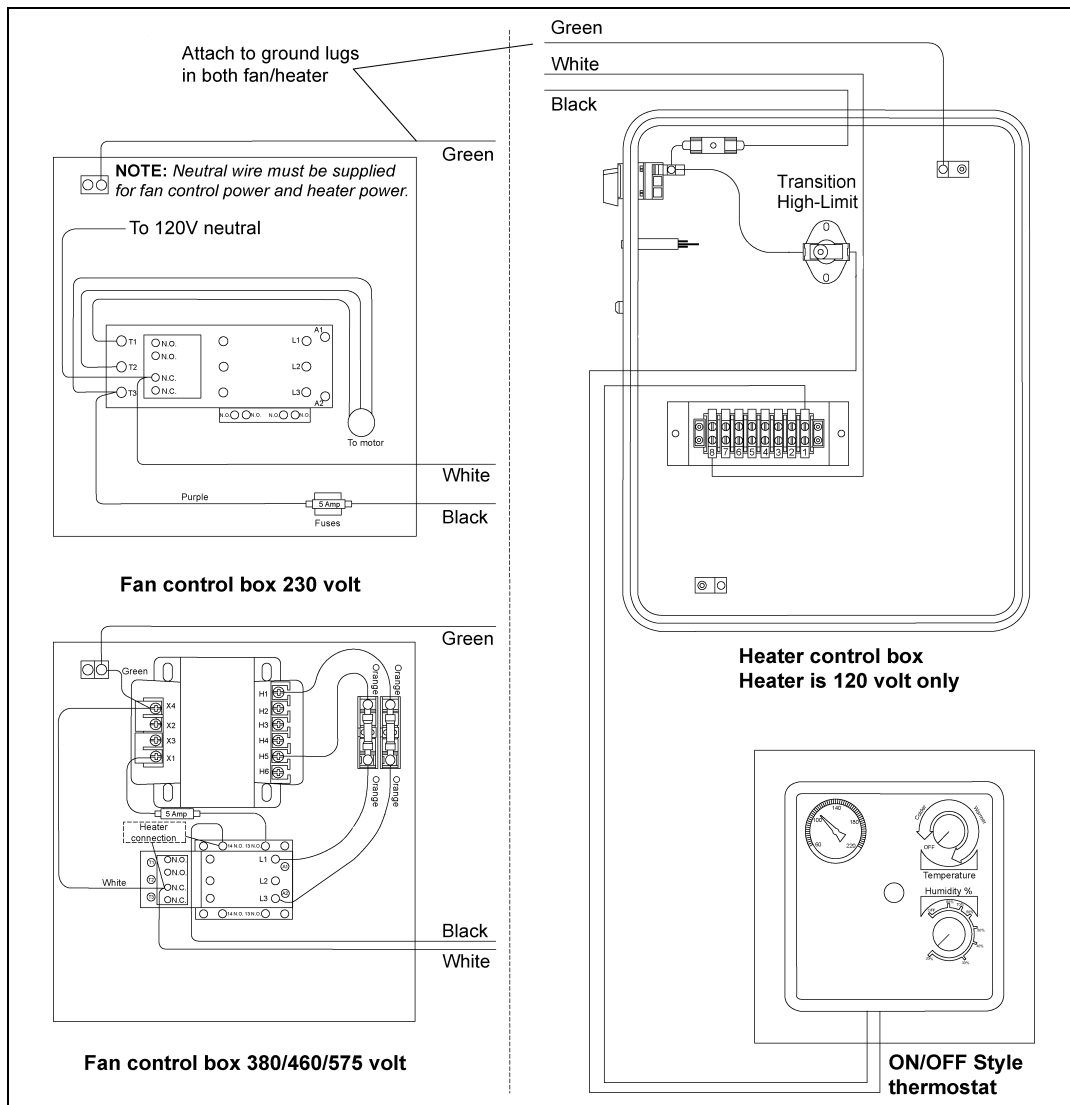

**Figure 5A** Heater Wiring Installation on a Fan Unit

## Standard Heater - Second Heater Installation

Two (2) standard heaters may be connected to one grain drying system and wired so they cycle together. One of the heaters should have a thermostat connected to it as per the installation instructions. That heater will be referred to as the primary. The other heater (without the thermostat) will be referred to as the secondary.

1. Install relay base (TD-100283) in primary heater control box.
2. Connect wire between terminal 13 on relay base to terminal 5 on terminal strip in primary heater.
3. Connect wire between terminal 14 on relay base to terminal 6 on terminal strip in primary heater.
4. Run two (2) wires (18 gauge) between primary and secondary heater.
5. Connect wires to terminals 5 and 9 (points A and B) on relay base in primary heater.
6. Connect wire from terminal 9 in primary to (point F) in secondary unit.
7. Connect wire from terminal 5 in primary to (point G) in secondary unit.
8. Install relay (TD-100282) in relay base.

Follow these additional steps for HIGH-LOW units.

1. Install relay base (TD-100283) in master heater control box.
2. Connect wire between terminal 13 on relay base to green wire from HIGH-LOW thermostat in master unit. Do not disconnect other wires from green wire 3. Connect wire between terminal 14 on relay base to terminal 14 on other relay base in master heater.
3. Run two (2) wires (18 gauge) between master and slave heater.
4. Connect wires to terminals 5 and 9 (points A and B) on relay base in master heater.
5. Connect wire from terminal 9 in master to terminal 6 (point G) in slave unit.
6. Connect wire from terminal 5 in master to cycle solenoid and red light in slave unit. Do not connect wire to side of cycle solenoid and light that are connected to terminal.

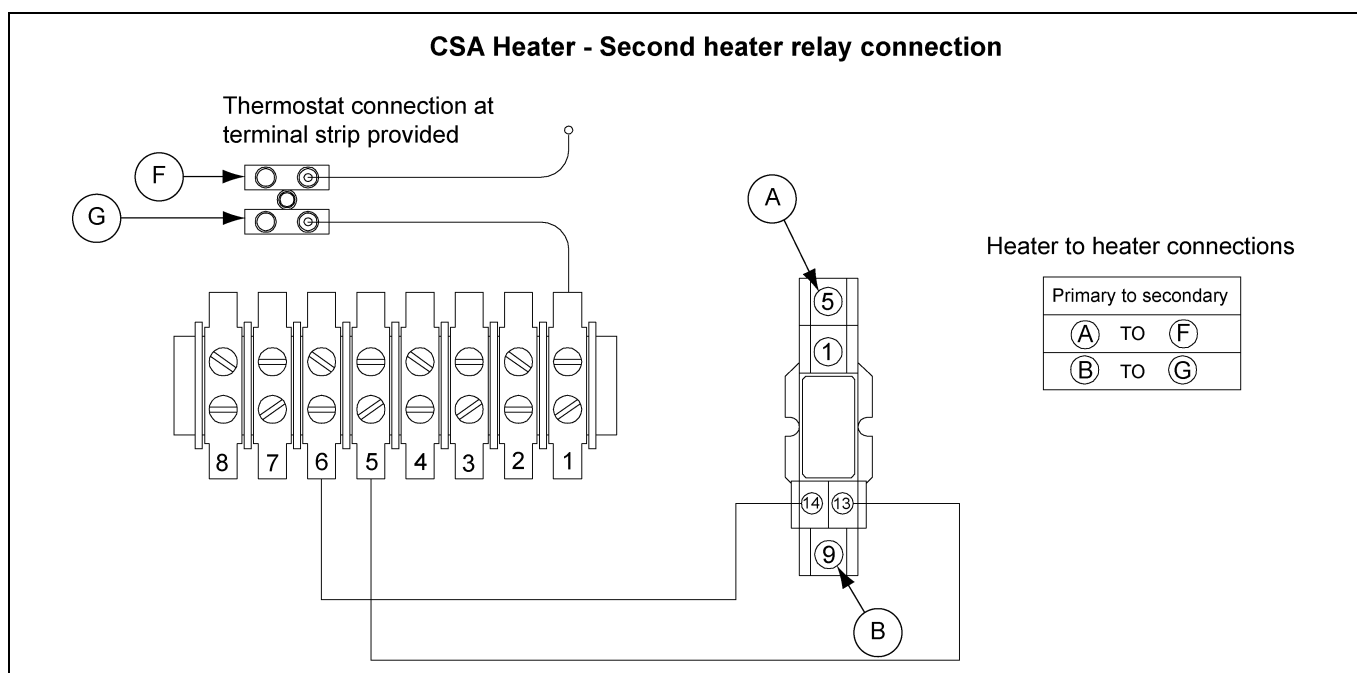

**Figure 5B CSA Heater - Second Heater Relay Connection**

## 5. Installation

### Bin Configuration

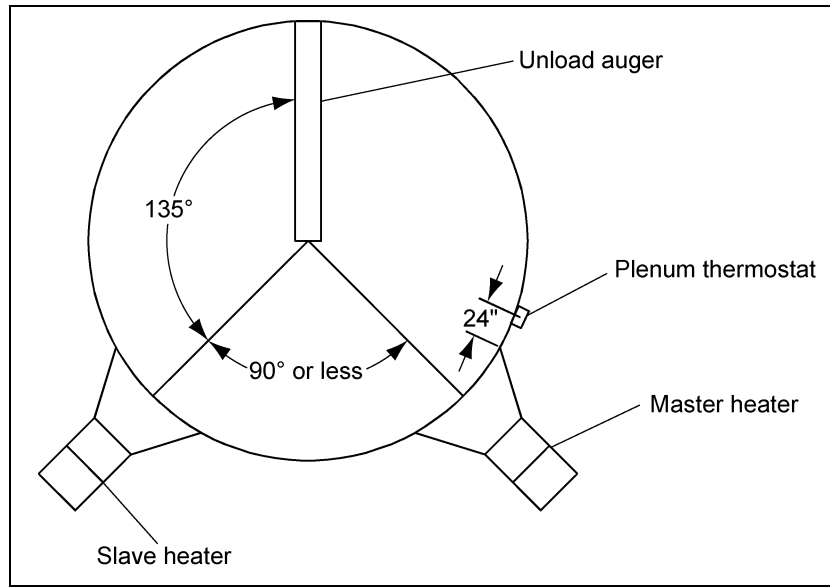

Figure 5C

**IMPORTANT:** When mounting two (2) heaters on a bin it is imperative that they be situated as shown in [Figure 5C](#). Plenum thermostat must be to the right of master heater and master heater must be to the right of slave heater.

### Plenum Thermostat Transition High-Limit Installation

1. Mark location on transition one foot up from the bottom (entrance collar) and centered in the transition.
2. Drill or knock out 7/8" diameter hole on marked location.
3. Install transition high-limit using supplied self-drilling screws.

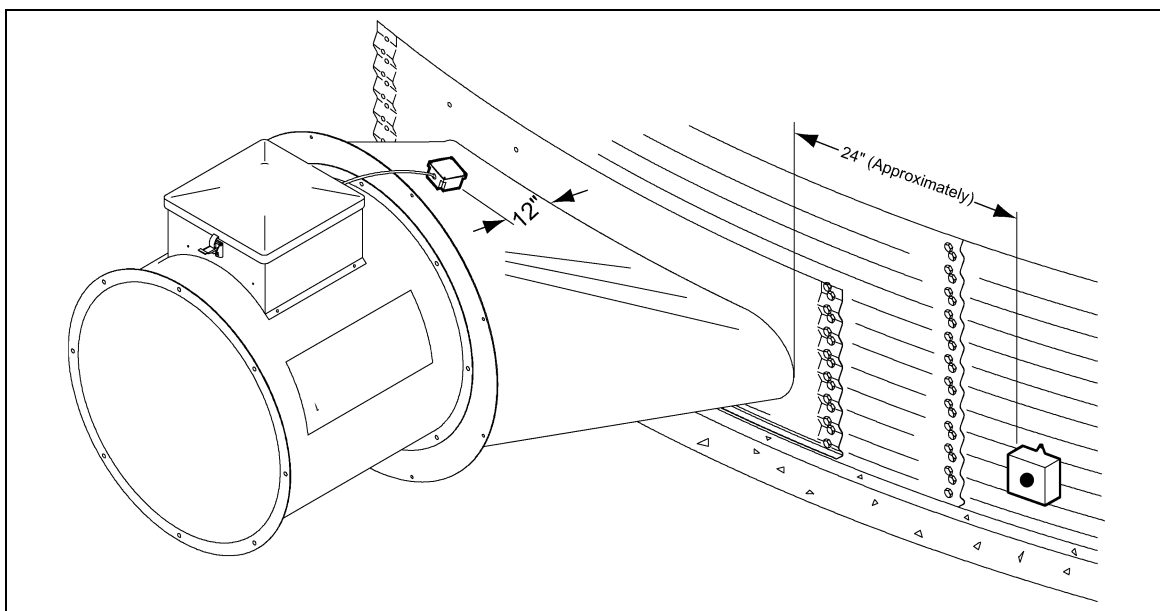

Figure 5D The transition connecting the Vane Axial Heater to the bin with the plenum sensor in place.



## Plenum Thermostat Mounting

The plenum thermostat must be ordered separately from the heater unit.

1. Follow installation instructions provided with the thermostat assembly.
2. Position the housing so that the bolt flanges are vertical and the cord exits the housing from the bottom. Mark position.
3. Use 6 (4.00") or 8 (2.66") self-drilling screws to mount the housing to the bin sidewall. **DO NOT TIGHTEN COMPLETELY.** Insert corrugation seal into gap between housing and sidewall. Tighten screws.
4. Caulk between the housing and the sidewall to seal.



***Thermostat must be installed to operate as plenum high-limit safety.***

Heater control device (thermostat or humidistat) is required for heater warranty on all heaters.

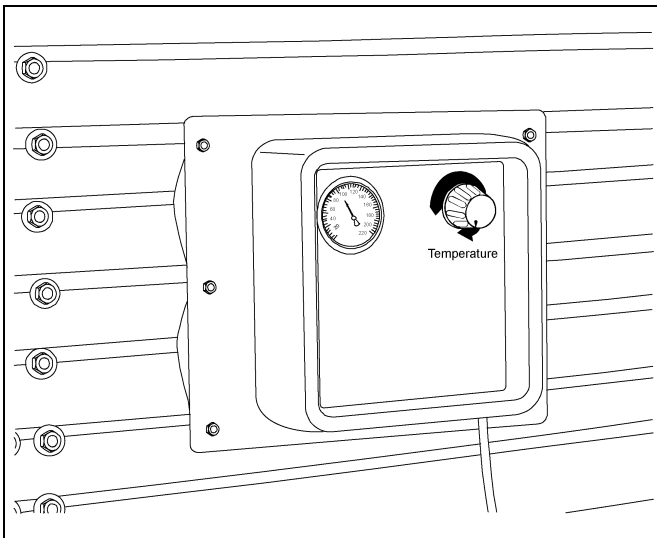

**Figure 5E** *Plenum thermostat mounted on bin wall.*

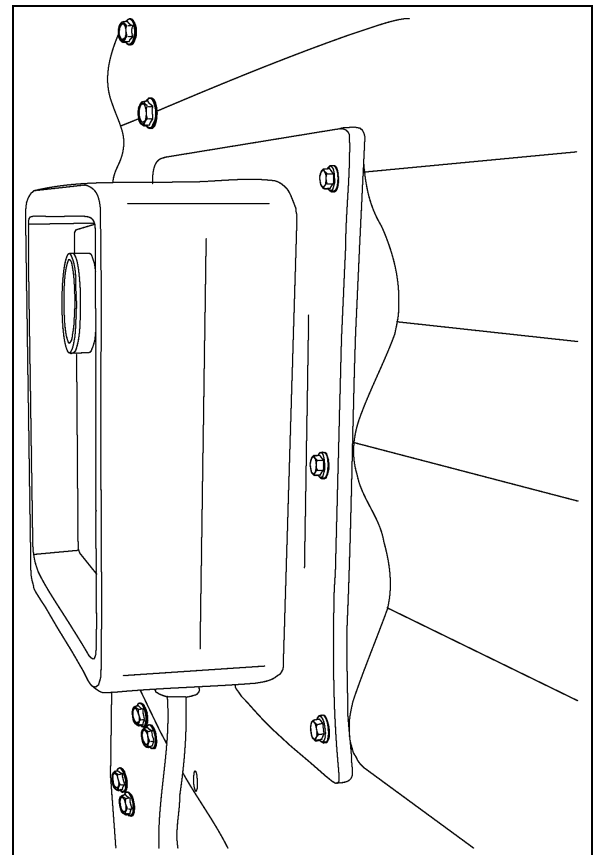

**Figure 5F** *Side view of thermostat showing corrugation seal.*

## 5. Installation

### Heater Orifice Setup

The factory has set the orifices size for propane, high temperature and natural gas, low temperature.

1. Determine the type of gas to be used: Propane or natural gas.
2. Determine the operating temperature ranges to be used: High or low. Refer to tables on [Page 22](#) and [Page 23](#).
3. For natural gas high temperature applications remove reducer bushing with pressure gauge and remove primary orifice from system. Replace reducer bushing and check connections for leaks. For natural gas high temperature configuration there is no primary orifice in the system. Refer to [Fuel - Temperature Table below](#).
4. For propane low temperature applications remove reducer bushing with pressure gauge and replace the supplied primary orifice with orifice supplied in control box. Replace reducer bushing and check connections for leaks. Refer to [Fuel - Temperature Table below](#).

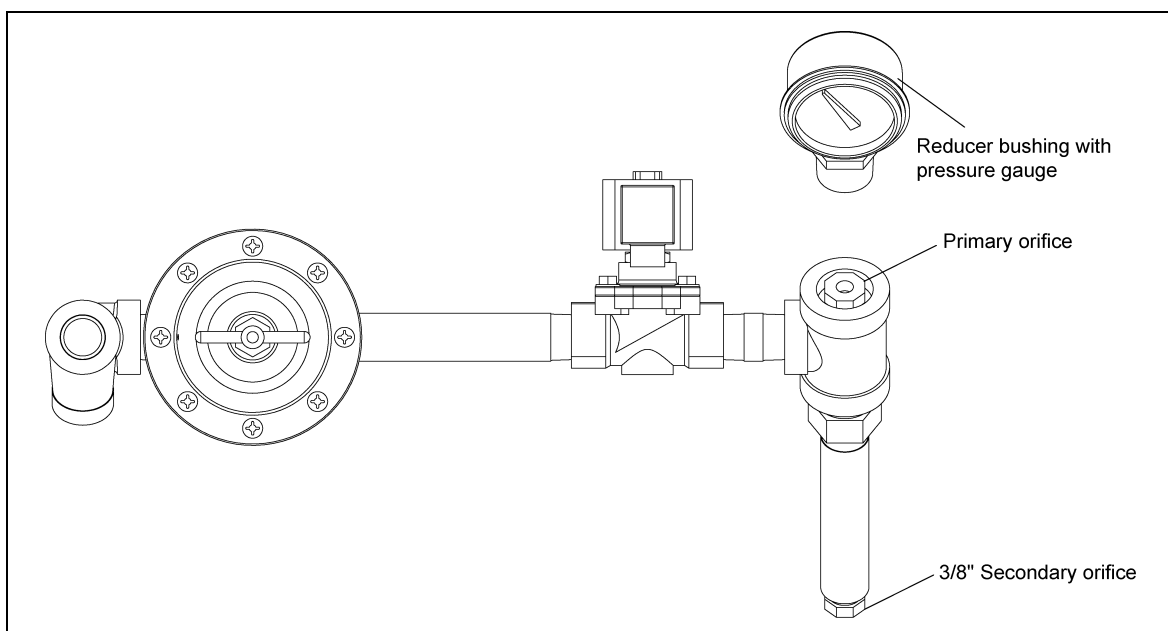

Figure 5G

#### Fuel - Temperature

Fuel	Temperature	
	High	Low
Natural Gas	Remove primary orifice completely.	No modifications required. Standard with 7/32" orifice.
Propane	No modifications required. Standard with 7/32" orifice.	Replace primary orifice with 3/32" orifice supplied in control box.



**Make sure the configuration matches the appropriate application in the [Fuel - Temperature Table above](#). Propane has a higher BTU content than natural gas. Do not remove 3/8" secondary orifice. Excessive heat rise due to improper orifice sizing or removing the 3/8" secondary orifice will damage grain or cause fire.**

## Operating Temperature Table

**IMPORTANT:** *The **below table** is not intended as a drying guide. It should be used as a reference for setting maximum plenum temperature for safe operation.*



*Do not exceed plenum temperatures listed in **table below**.*

	Low Temperature Batch	High Temperature Batch Dry No Stirring	High Temperature with Stirring	Continuous Flow (Recirculating)
<b>Corn</b>	5°-20° above Ambient Temperature	120°	140°	160°
<b>Rice</b>	5°-10° above Ambient Temperature	100°	100°	Not Recommended
<b>Beans and Wheat</b>	5°-20° above Ambient Temperature	110°	120°	Not Recommended

## Cycling Heater Operation

1. Thermostat must be wired into heater control box for heater to operate.
2. Open all manual shut off valves to heater unit.
3. Start fan. This will supply power to heater.
4. Turn thermostat dial to its highest setting.
5. Turn toggle switch ON.
6. Heater will lite after purge. If heater fails to lite check to see that all gas is ON.
7. Watch thermometer on plenum and when it reaches desired temperature turn thermostat back slowly until heater cycles OFF.
8. Gas pressure should be adjusted so burner is ON 75% of the time.
9. Watch plenum temperature as burner goes through a few cycles, to be sure that it is operating properly.

## 6. Operation

### High-Low Heater Operation

1. High-Limit and cycling thermostat must be wired into heater control box for heater to operate.
2. Open all manual shut off valves to heater unit.
3. Start fan. This will supply power to heater.
4. Turn thermostat dial to its highest setting.
5. Turn toggle switch ON. Both lights should illuminate indicating power to the control circuit.
6. Heater will lite after purge. If heater fails to lite check to see that all gas is ON.
7. Open adjustment screw on solenoid valve all the way.
8. Turn thermostat dial back slowly until heater cycles to low flame.
9. Adjust screw on solenoid valve so that low flame pressure is at desired setting. (As low as possible.)
10. Turn thermostat dial to desired setting and wait for bin plenum to come up to temperature. Heater should cycle to low flame after a few minute.
11. If heater does not cycle to low flame increase high flame gas pressure by adjusting the regulator.
12. High flame should be adjusted so the heater cycles 75% of the time. Low flame should be adjusted so there is enough flame for unit to keep operating.
13. Watch as burner goes through a few cycles, to be sure that it is operating properly back to high flame.

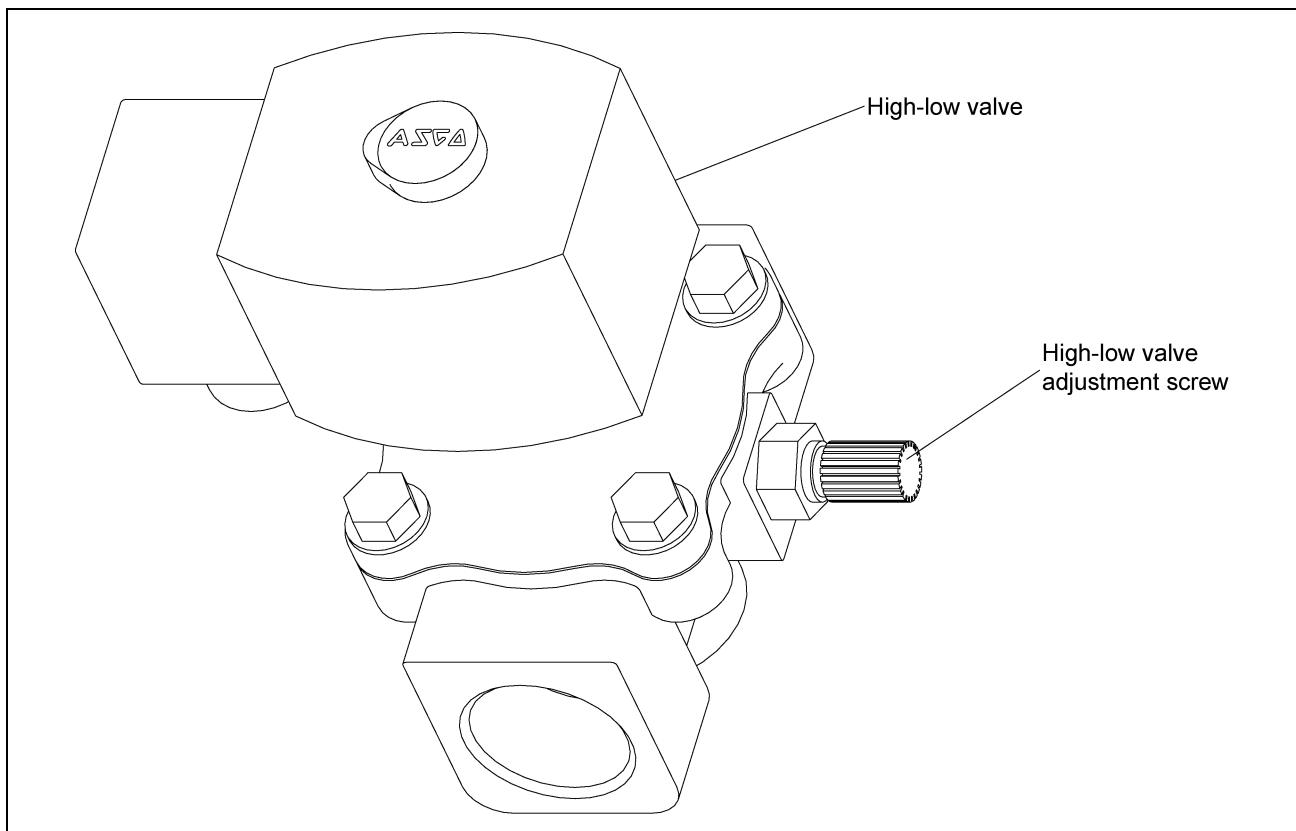

Figure 6A

## Adjusting the Vaporizer

1. Vaporizer should be adjusted so the vapor pipe train runs warm to the touch (100°-120°F).
2. Loosen 5/16" pivot bolts on adjustment bracket.
3. Tilt vaporizer away from burner to cool. Tilt toward burner to heat. Vaporizer may be raised or lowered for vertical adjustments.
4. Tighten 5/16" pivot bolts to fix vaporizer position.

**IMPORTANT:** Only move vaporizer 1" at a time. Allow heater to run a few minutes for temperature to equalize.

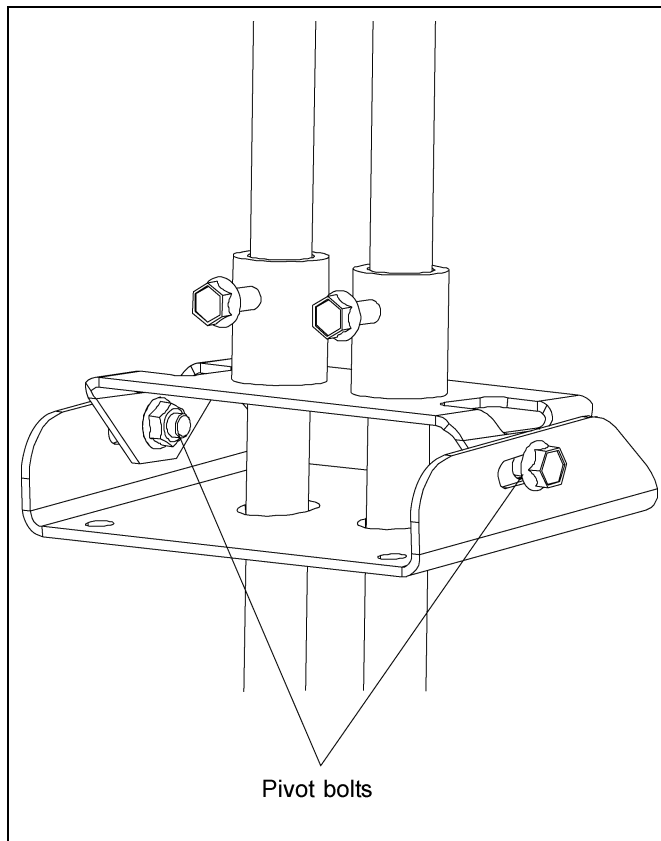

Figure 6B

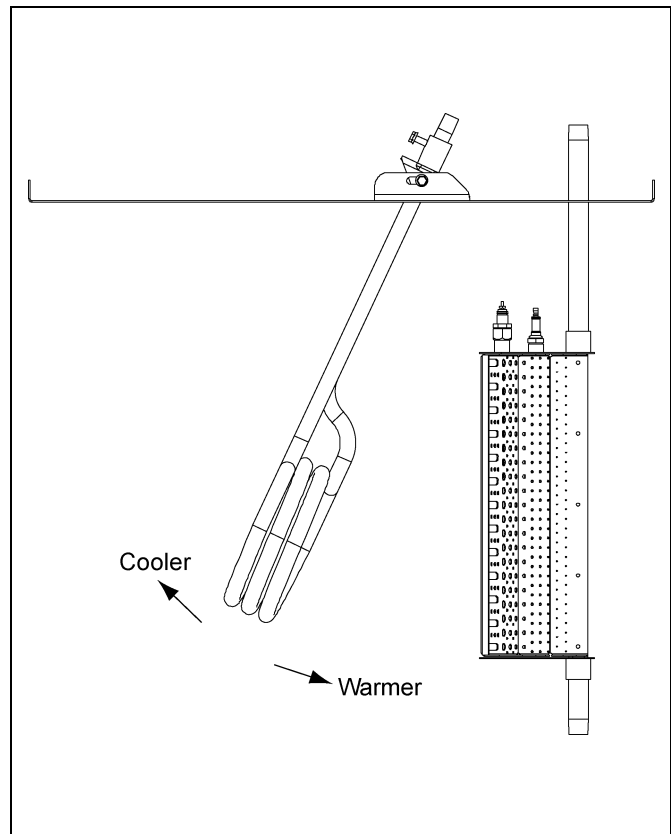

Figure 6C

**Vaporizer adjustment:** Away from burner to cool. Toward burner to heat.

## 6. Operation

### BTUs for Gauge Pressure (PSI) Reading Propane Models (Approximate)

#### High Temperature

Diameter	Operating Pressure (PSI)									
	2	4	6	8	10	12	14	16	18	20
24"	1,821,128	2,487,296	3,054,193	3,539,643	3,960,025	4,330,275	4,663,886	4,972,904	5,267,934	5,558,136
28"	2,622,425	3,581,706	4,398,038	5,097,085	5,702,436	6,235,596	6,715,995	7,160,981	7,585,825	8,003,715

#### Low Temperature

Diameter	Operating Pressure (PSI)									
	2	4	6	8	10	12	14	16	18	20
24" and 28"	455,282	621,824	763,548	884,911	990,006	1,082,569	1,165,971	1,243,226	1,316,983	1,389,534

#### Gauge Pressure (PSI) Reading to Maintain Temp (Approximate)

Diameter	Static Pressure	Heat Rise (F)						
		60	80	100	120	140	160	180
5 HP - 24"	1"	1	3	4	6	7	9	12
	2"	1	2	3	5	6	8	10
	3"	Low Temp	1	2	3	4	5	7
	4"	Low Temp	Low Temp	1	2	2	3	4
7 HP - 24"	1"	2	3	5	6	8	11	13
	2"	1	2	4	5	7	9	11
	3"	Low Temp	2	3	4	5	7	8
	4"	Low Temp	Low Temp	1	2	3	4	5
10 HP - 24"	1"	2	3	5	7	10	12	16
	2"	1	3	4	6	8	10	12
	3"	Low Temp	2	3	4	6	7	9
	4"	Low Temp	Low Temp	2	2	3	4	5
15 HP - 28"	1"	2	3	5	7	9	12	16
	2"	2	3	4	6	8	10	13
	3"	1	2	3	5	6	8	10
	4"	Low Temp	2	3	4	5	6	8
	5"	Low Temp	Low Temp	2	2	3	4	5

## BTUs for Gauge Pressure (PSI) Reading Natural Gas Models (Approximate)

### High Temperature

Diameter	Operating Pressure (PSI)									
	1	2	3	4	5	6	7	8	9	10
18"	659,337	831,044	989,238	1,135,039	1,269,526	1,393,734	1,508,661	1,615,262	1,714,449	1,807,097
24"	912,577	1,150,234	1,369,188	1,570,989	1,757,129	1,929,044	2,088,112	2,235,656	2,372,940	2,501,172
28"	1,314,110	1,656,337	1,971,631	2,262,224	2,530,266	2,777,823	3,006,882	3,219,345	3,417,034	3,601,688

### Low Temperature

Diameter	Operating Pressure (PSI)									
	1	2	3	4	5	6	7	8	9	10
18"	184,797	232,922	277,261	318,125	355,819	390,631	422,843	452,720	480,520	506,487
24" and 28"	82,132	103,521	123,227	141,389	158,142	173,614	187,930	201,209	213,565	225,105

### Gauge Pressure (PSI) Reading to Maintain Temp (Approximate)

Diameter	Static Pressure	Heat Rise (F)						
		60	80	100	120	140	160	180
3 HP - 18"	1"	Low Temp	Low Temp	2	2	3	4	5
	2"	Low Temp	Low Temp	Low Temp	1	2	3	3
5 HP - 24"	1"	1	2	3	5	6	8	10
	2"	Low Temp	2	3	4	5	6	8
	3"	Low Temp	Low Temp	2	3	3	4	5
7 HP - 24"	1"	1	2	4	5	7	8	10
	2"	1	2	3	4	6	7	9
	3"	Low Temp	1	2	3	4	5	7
	4"	Low Temp	Low Temp	1	2	2	3	4
10 HP - 24"	1"	1	3	4	6	8	10	10
	2"	1	2	3	5	6	8	10
	3"	Low Temp	2	3	4	5	6	7
	4"	Low Temp	Low Temp	1	2	3	3	4
15 HP - 28"	1"	1	3	4	6	8	10	10
	2"	1	2	3	5	6	8	10
	3"	1	2	3	4	5	7	8
	4"	Low Temp	1	2	3	4	5	6
	5"	Low Temp	Low Temp	1	2	2	3	4

## 7. Service

---

All heaters are constructed of durable weather-resistant materials, so a minimum amount of service should be required. Before the unit is started for the first time each season there are a few items that need to be checked out. All damaged parts should be repaired or replaced.

1. Disconnect and lock out power to fan/heater. Open control box lid and inspect all components for moisture, vibration or rodent damage. Inspect and tighten all loose terminal connections. Replace any damaged wiring.
2. Remove burner orifice tube and inspect for dirt or foreign material. Clean out if necessary.
3. Inspect holes in burner ring for possible corrosion or plugging with dirt or rust. Clean if necessary.
4. Be sure primary air inlet screen is intact and clean for proper burn.
5. Check perforated ring on natural gas models to be sure it is clean and no holes are plugged.
6. Inspect flame probe and ignitor and adjust or replace if necessary.



***Always disconnect and lock out power before working on or around heater.***



## 8. Troubleshooting - Heater

Trouble	Probable Cause	Check-out Procedure
Burner will not fire. No gas pressure on gauge. No ignition spark.	1. Heater not wired.	1. Visually check fan control box to see if wires are connected.
	2. Fan not running.	2. Fan contactor must be energized for heater to run.
	3. Blown fuse.	3. Visually check fuse.
	4. Bad ON/OFF switch.	4. Check ON/OFF switch contact block for proper installation and continuity. Check for power on terminals 1 and 8.
	5. Housing high-limit switch.	5. Reset switch. Check for power on terminals 1 and 8.
	6. Thermostat open.	6. Plenum temperature above set point temperature or open circuit.
	7. Flame probe open.	7. Remove wires from flame probe and check with ohm meter. Probe should be closed when cold.
Burner will not fire. No gas pressure on gauge. Constant ignition spark.	1. Gas supply.	1. Make sure all valves are open to heater and gas tank is not empty.
Burner will not fire. Gas pressure on gauge. No ignition spark.	1. Loose wire.	1. Check for power on terminals 4 and 7. Look for loose wires or incorrect wiring.
	2. Ignitor/spark plug.	2. Turn gas OFF to heater. Check gap on ignitor. Check porcelain for any sign of cracks. Remove plug wire from spark plug/ignitor. Carefully holding wire by insulation. Try to get an arc between end of wire and heater housing (or other wire using two (2) pole transformer).
	3. Ignition transformer/wire.	3. Turn gas OFF to heater. If no spark present after checking ignitor, remove wire from ignition transformer. Check for spark at ignition transformer with an insulated screwdriver. Spark should jump a minimum 1/4" gap. Replace transformer if no spark is established, replace the ignition wires.
Burner will not fire or fires for 30 second and locks out. Gas pressure on gauge. Spark is ON.	1. Plugged orifice.	1. Check for gas at burner. If no gas, remove pipe train and check orifice and burner ring for blockage.
	2. Flame probe.	2. Check to be sure flame probe is in good condition and is located in flame. Flame probe contacts should open when probe gets hot.
	3. Incorrect supply voltage.	3. Voltage to heater must be 110V AC.
	4. Regulator set too low.	4. See that flame burns continuous and is not intermittent. On ring burners be sure flame burns completely around ring.
	5. Moisture in fuel.	5. Have tank and lines checked by a qualified gas service man.

# Heater Wiring

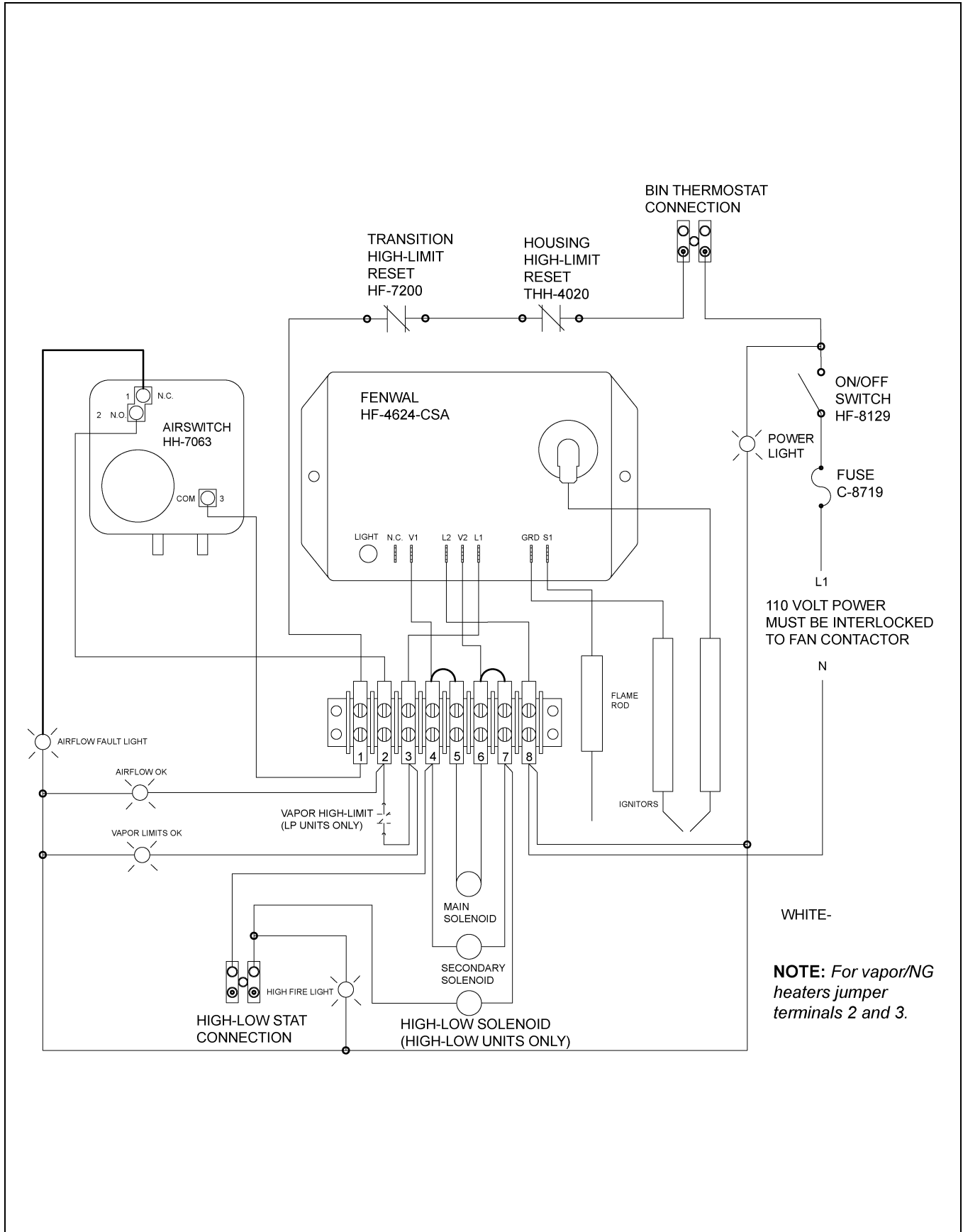

# Standard Heater Schematic

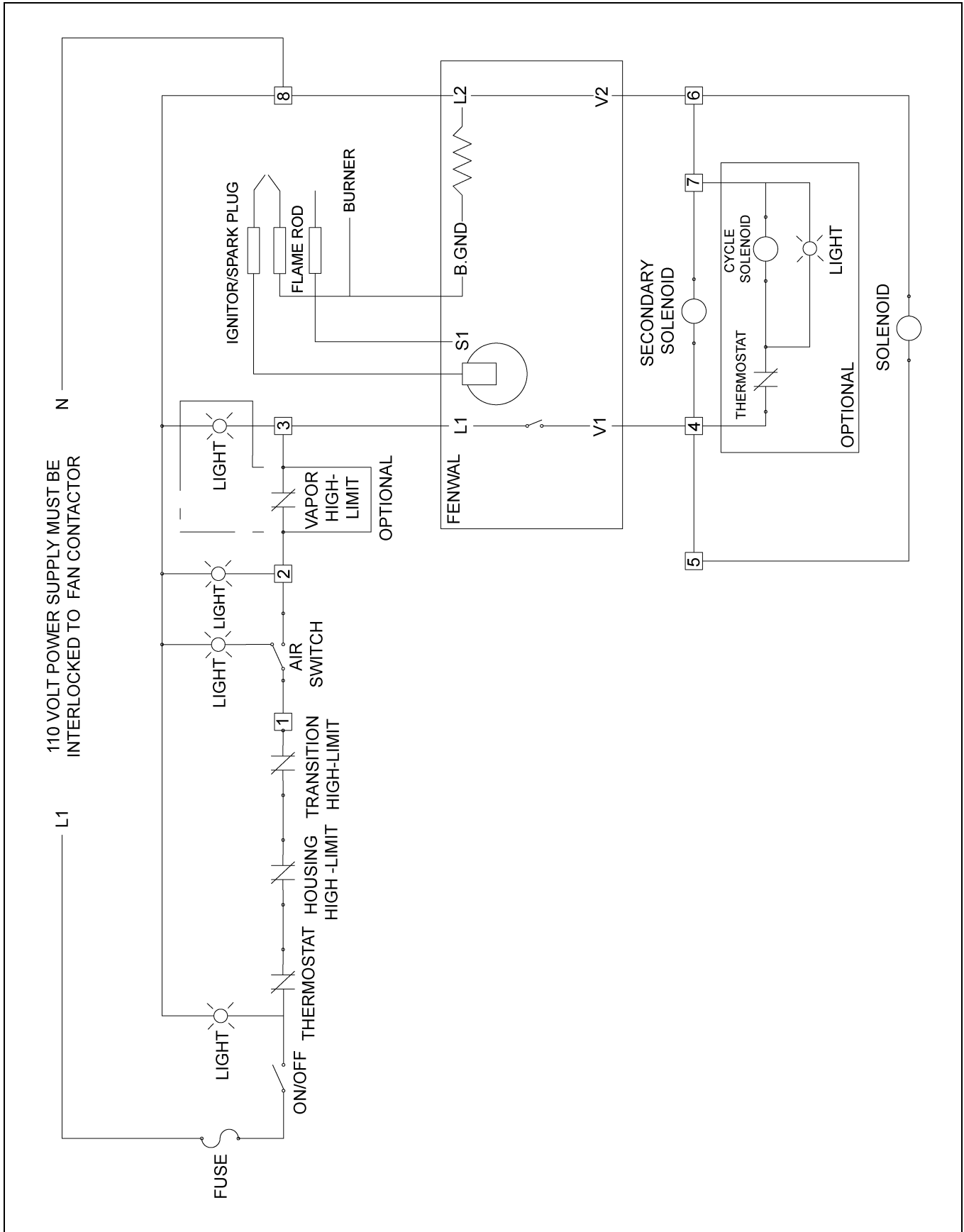

---

# NOTES

1. **CSA Heater Control Box Assembly (HF-8184)** - *(See Pages 30-31.)*
2. **18", 24" and 28" Gas Heater Parts** - *(See Pages 32-33.)*
3. **18" Vapor/NG Pipe Train Assembly** - *(See Page 34.)*
4. **24" and 28" LP Pipe Train Assembly** - *(See Page 35.)*
5. **24" and 28" LP High-Low Pipe Train Assembly** - *(See Page 36.)*
6. **24" and 28" Propane Vapor Pipe Train Assembly** - *(See Page 37.)*
7. **24" and 28" Propane Vapor High-Low Pipe Train Assembly** - *(See Page 38.)*
8. **24" and 28" Vapor/NG High-Low Pipe Train Assembly** - *(See Page 39.)*
9. **LP Supply Pipe Train Assembly** - *(See Page 40.)*

# CSA Heater Control Box Assembly (HF-8184)

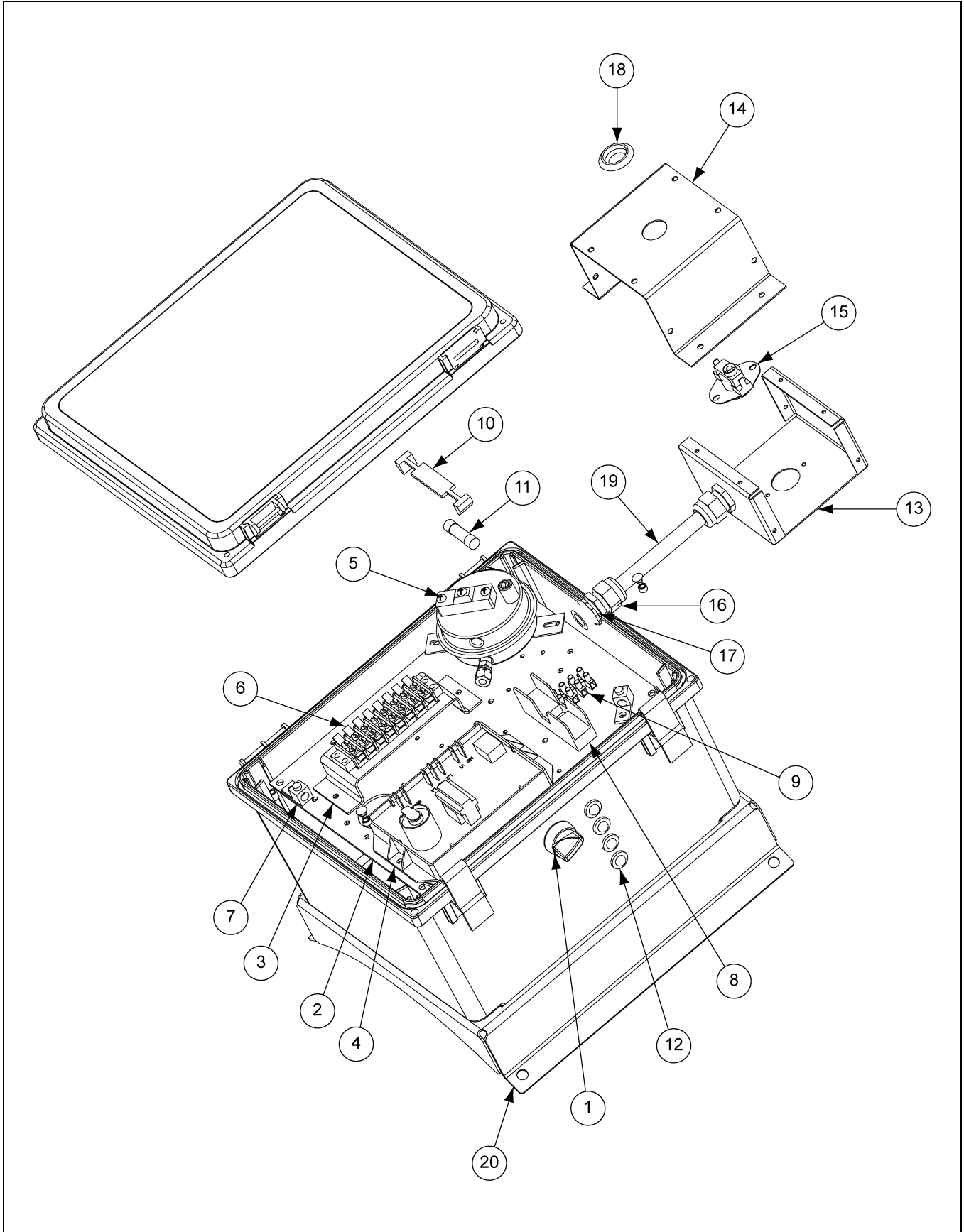

## CSA Heater Control Box Assembly (HF-8184) Parts List

Ref #	Part #	Description	Qty
1	DSA-VIS-POWR	Dryer Switch Assembly Vis Power ON/OFF	1
2	C-8707	Control Box Backing Plate - C-8705	1
3	HF-7697	Term Strip Bracket	1
4	HF-4624-CSA	Fenwal, Flame Detection Board - CSA Version 15 Sec Purge	1
5	AIRSWITCH	Switch, Air (Antunes)	1
6	TFH-2013	Terminal, Strip 8 Conductor ELD-8-009	1
7	E160-1137	Lug Ground, #TA-2 (CSA)	2
8	C-8718	Single Pole Midget Fuse Block	1
9	E240-1107	Terminal Strip 12 Position 10A 12 Gauge	1
10	C-8715	1-1/2" x 13/32" Fuse Puller	1
11	C-8719	Slow Blow 2A Midget Fuse 500 VAC, 10 KA I.R.	1
12	90-0009	Lamp, Oil Tight 1/4" Tab 120V Amber	4
13	HF-7454	High-Limit Box Body	1
14	HF-7455	High-Limit Box Lid	1
15	HF-7439	Switch High-Limit 250°	1
16	FH-1310	Cord Connector, Heyco	2
17	FH-1309	Lock Nut 1/2" #401 ARL.	2
18	048-1018-0	Hole Plug - BP - 7/8"	1
19	WR-163SOOWA	Wire, 16/3 Type Soow-A Yellow	1
20	FH-7401	C-8705 Adapter Plate - 24" VA	1
20	FH-7402	C-8705 Adapter Plate - 28" VA	1
20	FH-7403	C-8705 Adapter Plate - 18" VA	1

## 10. Parts List

### 18", 24" and 28" Gas Heater Parts

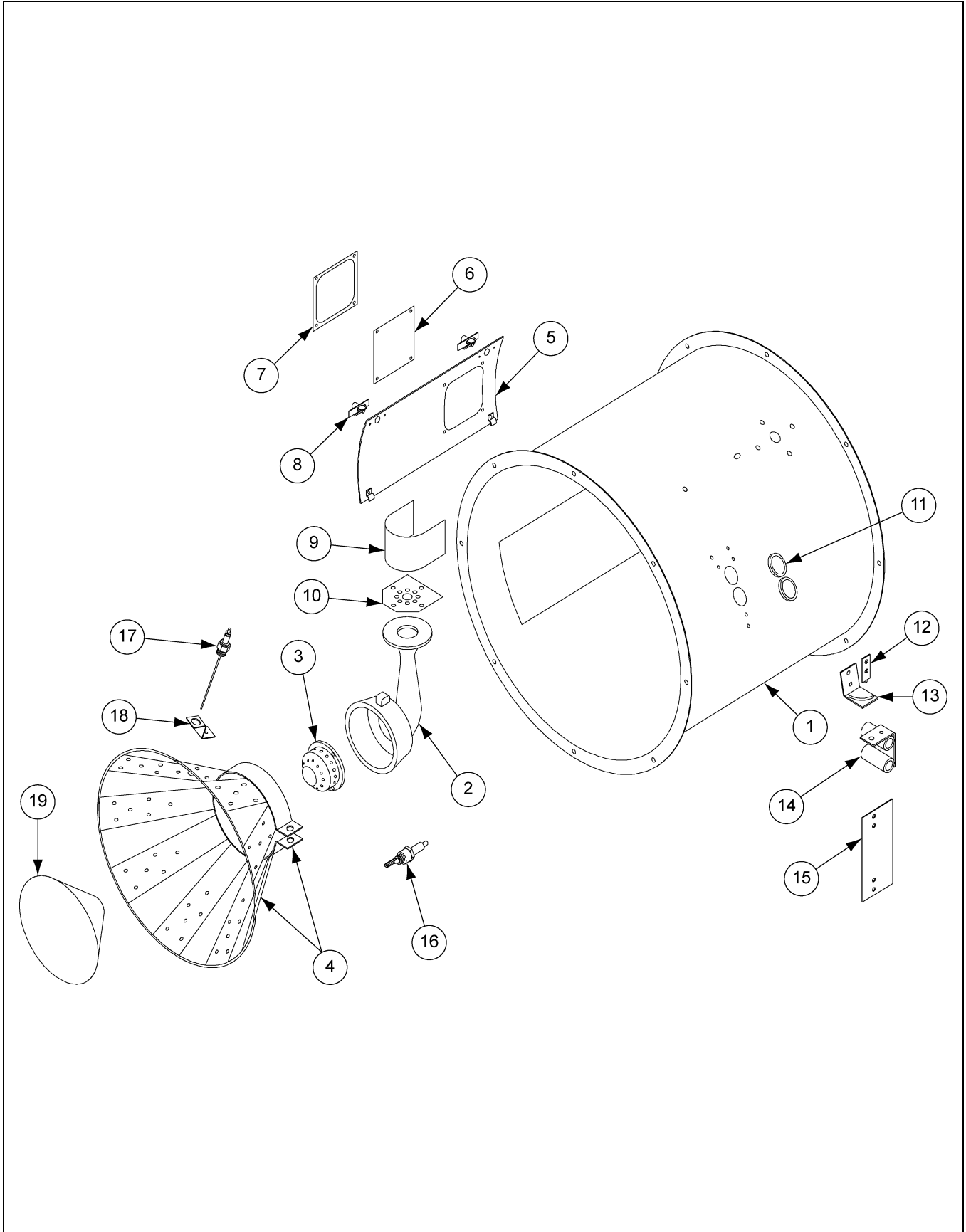



## 18", 24" and 28" Gas Heater Parts List

Ref #	Part #			Description
	18"	24"	28"	
1	HF-8211	HF-8212	HF-8213	Heater Housing
2	HH-3934	HH-3934	HH-3934	Burner Casting
3	HF-6757	HF-6757	HF-6757	Flame Spreader (Low Temperature)
4	HF-992	HF-992	HF-992	Flame Diverter Weldment
5	HF-6062-18	HF-6065-24	HF-6065-28	Access Panel
6	HF-7380	HF-7380	HF-7380	Plastic View Window
7	HF-7379	HF-7379	HF-7379	Access Panel Cover Plate
8	TFH-2046	TFH-2046	TFH-2046	Access Panel Latch
9	HF-986	HF-983	HF-7517	Burner Collector
10	HF-978	HF-978	HF-978	Burner Collector Plate
11	N/A	HH-7016	HH-7016	Rubber Grommet - LP Model Only
12	N/A	HF-7056	HF-7056	Pivot Bracket - LP Model Only
13	N/A	HF-7057	HF-7057	Adjustment Bracket - LP Model Only
14	N/A	HF-7060	HF-7060	Vaporizer Support Weldment - LP Model Only
15	N/A	THF-3237	THF-3237	Vaporizer Cover - Vapor/NG Only
16	HH-1650	HH-1650	HH-1650	Spark Plug
17	THH-4179	THH-4179	THH-4179	Flame Sensor
18	CD-0187	CD-0187	CD-0187	Flame Sensor Bracket
19	N/A	HH-7054	HH-7054	Burner Cone
N/S	053-1004-0	053-1004-0	053-1004-0	Spark Plug Nut
N/S	HF-7262	HF-7262	HF-7262	Flame Sensor Wire Assembly
N/S	HH-5430	HH-5430	HH-5430	Flame Probe Wire Assembly
N/S	HF-7260	HF-7260	HF-7260	Spark Plug Wire Assembly
N/S	7098556	7098556	7098556	Shroud, for 16" Motor Cord

## 10. Parts List

### 18" Vapor/NG Pipe Train Assembly

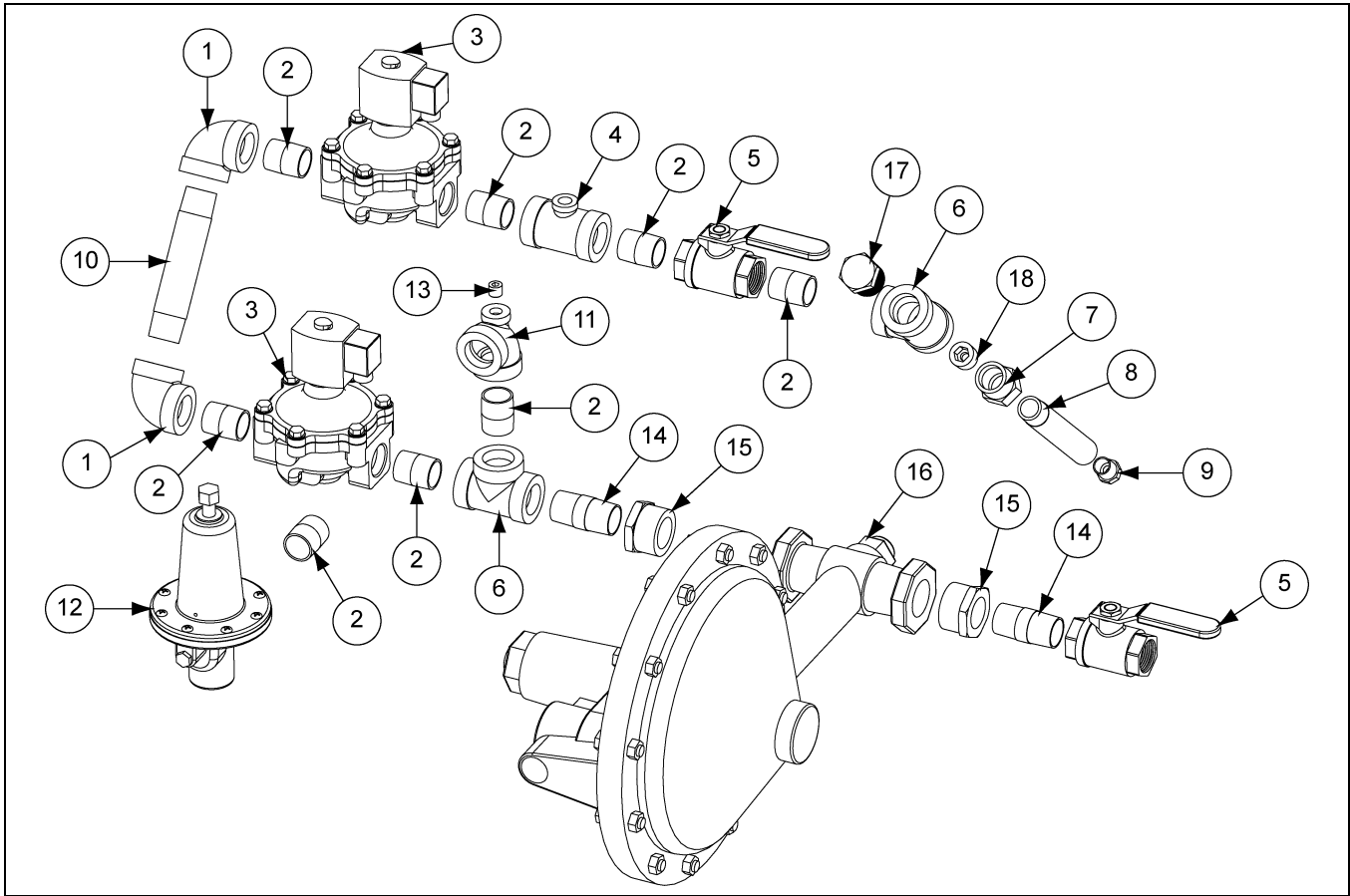

**18" Vapor/NG Pipe Train Assembly Parts List**

Ref #	Part #	Description	Qty	Diameter
1	THH-4115	Elbow, 1"-90° SCH 40 Black	2	All
2	THH-4117	Nipple, 1" Close SCH 40 Black	8	All
3	056-2224-6	Valve, Solenoid 1" NPT 115V Din	2	All
4	THH-4152	Tee, 1" x 1" x 1/4" SCH 40 Black	1	All
5	D03-0838	Valve, 1" NPT Full Port, Lever, CSA, Brass	2	All
6	THH-4137	Tee, 1" x 1" x 1" SCH 40 Black	2	All
7	HF-7794	Orifice Holder - Quad Heater - 3/4"	1	All
8	HH-7027	Orifice Pipe, 3/4" x 6-1/2"	1	All
9	HH-7126	Orifice (3/4") Drilled 3/8"	1	All
10	THH-4116	Nipple, 1" x 6" SCH 40 Black	1	All
11	THH-4163	Tee, 1" x 1/4" x 1" SCH 40 Black	1	All
12	D03-0881	Valve, Relief - 15-50 PSI Spring LP, 1" NPT, 300F Rating	1	All
13	FLX-3788	Plug, 1/4" NPT Pipe	1	All
14	THH-4037	Nipple, 1" x 2-1/2" SCH 40 Black	2	All
15	D08-0007	Reducer, 1-1/2" x 1" Hex Bushing	2	All
16	D08-0819	Regulator, NG 4-10 PSI Spring, 1.19 Orifice, 1-1/2" NPT	1	All
17	D08-0014	Plug, 1" Square Black	1	All
18	HF-7915	Orifice Plug, (3/4") Drill: 19/64"	1	18" High
18	406-2456-1	Orifice Plug, 3/4" NPT x 0.344"	1	24" High
18	406-2441-3	Orifice Plug, 3/4" NPT x 0.406"	1	28" High

## 24" and 28" LP Pipe Train Assembly

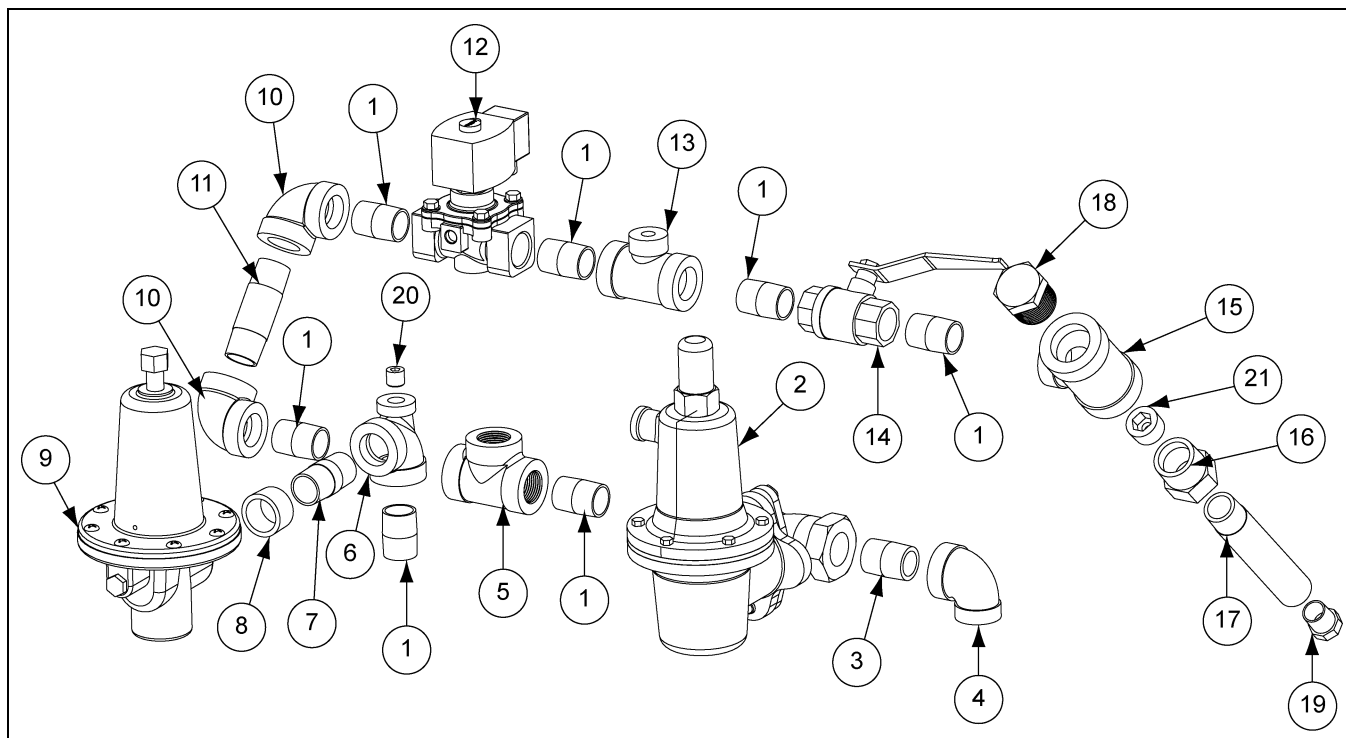

### 24" and 28" LP Pipe Train Assembly Parts List

Ref #	Part #	Description	Qty	Diameter
1	THH-4121	Nipple, 3/4" Close SCH 40 Black	7	24" and 28"
2	D03-0880	Regulator, LP 5-20 PSI Spring, 0.5 Orifice, 3/4" NPT	1	24" and 28"
3	D67-0021	Nipple, 3/4" Close SCH 80 Black	1	24" and 28"
4	THH-4149	Elbow, 3/4" x 1/2" Reducing 90° SCH 40 Black	1	24" and 28"
5	THH-4124	Tee, 3/4" x 3/4" x 3/4" SCH 40 Black	1	24" and 28"
6	THH-4158	Tee, 3/4" x 1/4" x 3/4" SCH 40 Black	1	24" and 28"
7	THH-4125	Nipple, 3/4" x 2" SCH 40 Black	1	24" and 28"
8	007-1338-8	Bushing, Flush 1" to 3/4"	1	24" and 28"
9	D03-0881	Valve, Relief - 15-50 PSI Spring LP, 1" NPT, 300F Rating	1	24" and 28"
10	THH-4120	Elbow, 3/4"-90° SCH 40 Black	2	24" and 28"
11	THH-4136	Nipple, 3/4" x 3" SCH 40 Black	1	24" and 28"
12	056-2223-8	Valve, Solenoid 3/4" NPT 115V Din 50 PSI	1	24" and 28"
13	THH-4154	Tee, 3/4" x 3/4" x 1/4" SCH 40 Black	1	24" and 28"
14	D03-0837	Valve, 3/4" NPT Full Port, Lever, CSA, Brass or Bronze	1	24" and 28"
15	D08-0017	Tee, 1" x 1" x 3/4" SCH 40 Black	1	24" and 28"
16	HF-7794	Orifice Holder - Quad Heater - 3/4"	1	24" and 28"
17	HH-7026	Orifice Pipe, 3/4" x 5-1/2"	1	24" and 28"
18	D08-0014	Plug, 1" Square Black	1	24" and 28"
19	HF-7126	Orifice (3/4) Drilled 3/8"	1	24" and 28"
20	FLX-3788	Plug, 1/4" NPT Pipe	1	24" and 28"
21	HF-7749	Orifice Plug (3/4) Drill: 17/64"	1	24"
21	HF-7809	Orifice Plug (3/4) Drill: 5/16"	1	28"

## 10. Parts List

### 24" and 28" LP High-Low Pipe Train Assembly

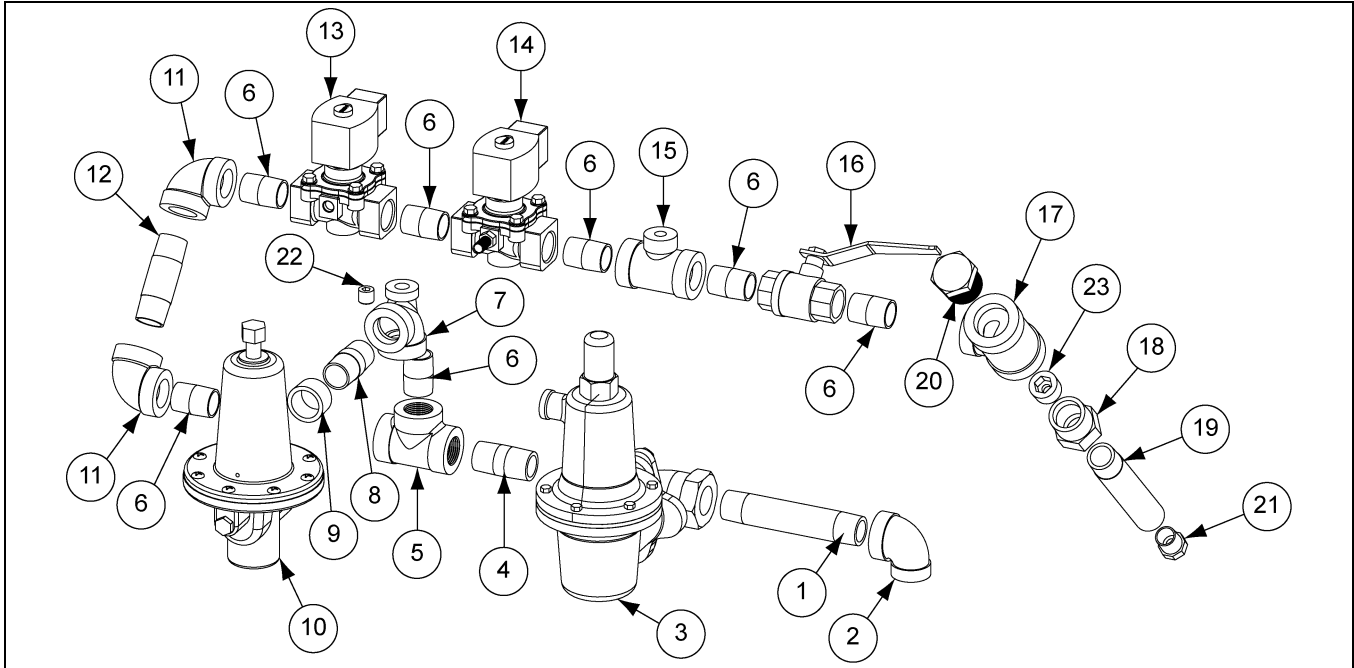

**24" and 28" LP High-Low Pipe Train Assembly Parts List**

Ref #	Part #	Description	Qty	Diameter
1	007-1913-8	Nipple, 3/4" x 5" SCH 80 Black	1	24" and 28"
2	THH-4149	Elbow, 3/4" x 1/2" Reducing 90° SCH 40 Black	1	24" and 28"
3	D03-0880	Regulator, LP 5-20 PSI Spring, 0.5 Orifice, 3/4" NPT	1	24" and 28"
4	007-1793-4	Nipple, 3/4" x 2" SCH 80 Black	1	24" and 28"
5	THH-4124	Tee, 3/4" x 3/4" x 3/4" SCH 40 Black	1	24" and 28"
6	THH-4121	Nipple, 3/4" Close SCH 40 Black	7	24" and 28"
7	THH-4158	Tee, 3/4" x 1/4" x 3/4" SCH 40 Black	1	24" and 28"
8	THH-4125	Nipple, 3/4" x 2" SCH 40 Black	1	24" and 28"
9	007-1338-8	Bushing, Flush 1" to 3/4"	1	24" and 28"
10	D03-0881	Valve, Relief - 15-50 PSI Spring LP, 1" NPT, 300F Rating	1	24" and 28"
11	THH-4120	Elbow, 3/4"-90° SCH 40 Black	2	24" and 28"
12	THH-4136	Nipple, 3/4" x 3" SCH 40 Black	1	24" and 28"
13	056-2223-8	Valve, Solenoid 3/4" NPT 115V Din 50 PSI	1	24" and 28"
14	056-2228-7	Valve, Solenoid 3/4" NPT 115V Din Bypass 30 PSI	1	24" and 28"
15	THH-4154	Tee, 3/4" x 3/4" x 1/4" SCH 40 Black	1	24" and 28"
16	D03-0837	Valve, 3/4" NPT Full Port, Lever, CSA, Brass or Bronze	1	24" and 28"
17	D08-0017	Tee, 1" x 1" x 3/4" SCH 40 Black	1	24" and 28"
18	HF-7794	Orifice Holder - Quad Heater - 3/4"	1	24" and 28"
19	HH-7026	Orifice Pipe, 3/4" x 5-1/2"	1	24" and 28"
20	D08-0014	Plug, 1" Square Black	1	24" and 28"
21	HF-7126	Orifice (3/4) Drilled 3/8"	1	24" and 28"
22	FLX-3788	Plug, 1/4" NPT Pipe	1	24" and 28"
23	HF-7749	Orifice Plug (3/4) Drill: 17/64"	1	24"
23	HF-7809	Orifice Plug (3/4) Drill: 5/16"	1	28"

## 24" and 28" Propane Vapor Pipe Train Assembly

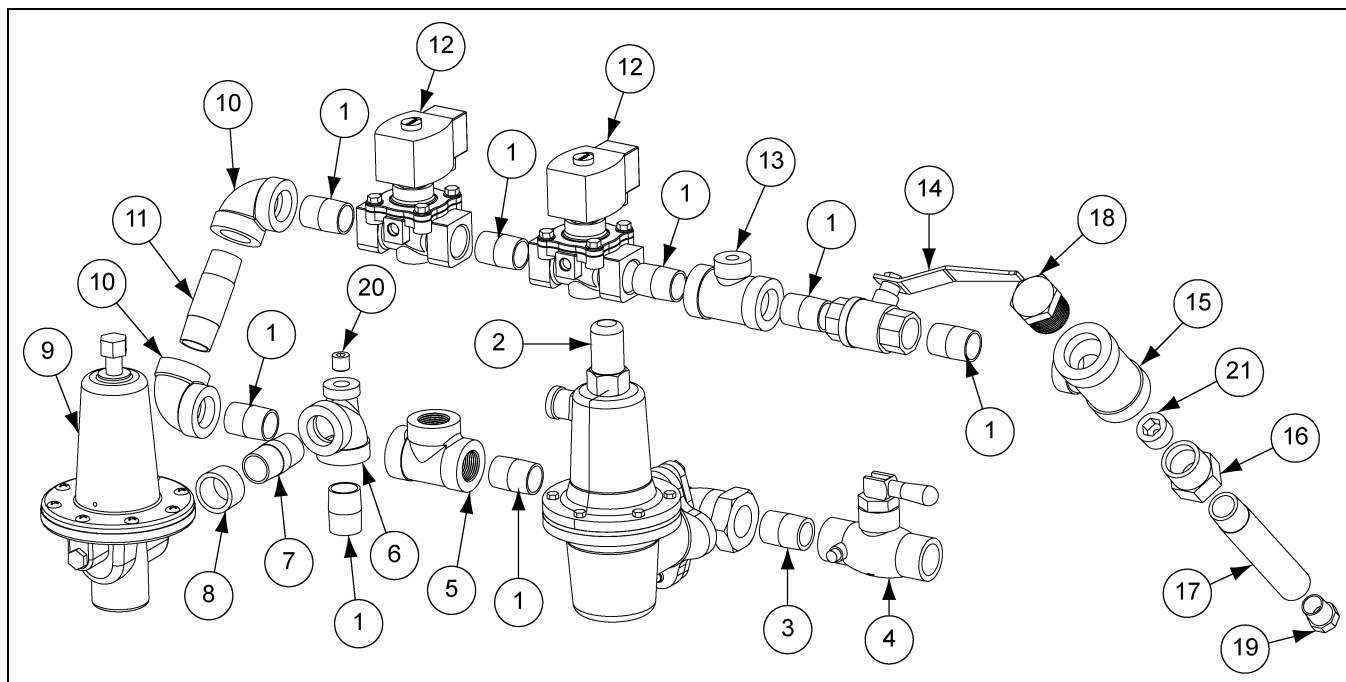

### 24" and 28" Propane Vapor Pipe Train Assembly Parts List

Ref #	Part #	Description	Qty	Unit
1	THH-4121	Nipple, 3/4" Close SCH 40 Black	8	All
2	D03-0880	Regulator, LP 5-20 PSI Spring, 0.5 Orifice, 3/4" NPT	1	All
3	D67-0021	Nipple, 3/4" Close SCH 80 Black	1	All
4	D03-0841	Valve, 3/4" NPT LP Quick Shut Off CSA	1	All
5	THH-4124	Tee, 3/4" x 3/4" x 3/4" SCH 40 Black	1	All
6	THH-4158	Tee, 3/4" x 1/4" x 3/4" SCH 40 Black	1	All
7	THH-4125	Nipple, 3/4" x 2" SCH 40 Black	1	All
8	007-1338-8	Bushing, Flush 1" to 3/4"	1	All
9	D03-0881	Valve, Relief - 15-50 PSI Spring LP, 1" NPT, 300F Rating	1	All
10	THH-4120	Elbow, 3/4"-90° SCH 40 Black	2	All
11	THH-4136	Nipple, 3/4" x 3" SCH 40 Black	1	All
12	056-2223-8	Valve, Solenoid 3/4" NPT 115V Din 50 PSI	2	All
13	THH-4154	Tee, 3/4" x 3/4" x 1/4" SCH 40 Black	1	All
14	D03-0837	Valve, 3/4" NPT Full Port, Lever, CSA, Brass or Bronze	1	All
15	D08-0017	Tee, 1" x 1" x 3/4" SCH 40 Black	1	All
16	HF-7794	Orifice Holder - Quad Heater - 3/4"	1	All
17	HH-7026	Orifice Pipe, 3/4" x 5-1/2"	1	All
18	D08-0014	Plug, 1" Square Black	1	All
19	HF-7126	Orifice (3/4) Drilled 3/8"	1	All
20	FLX-3788	Plug, 1/4" NPT Pipe	1	All
21	HF-7931	Orifice Plug (3/4) Drill: 13/64"	1	18" High
21	HF-7749	Orifice Plug (3/4) Drill: 17/64"	1	24" High
21	HF-7809	Orifice Plug (3/4) Drill: 5/16"	1	28" High

## 10. Parts List

### 24" and 28" Propane Vapor High-Low Pipe Train Assembly

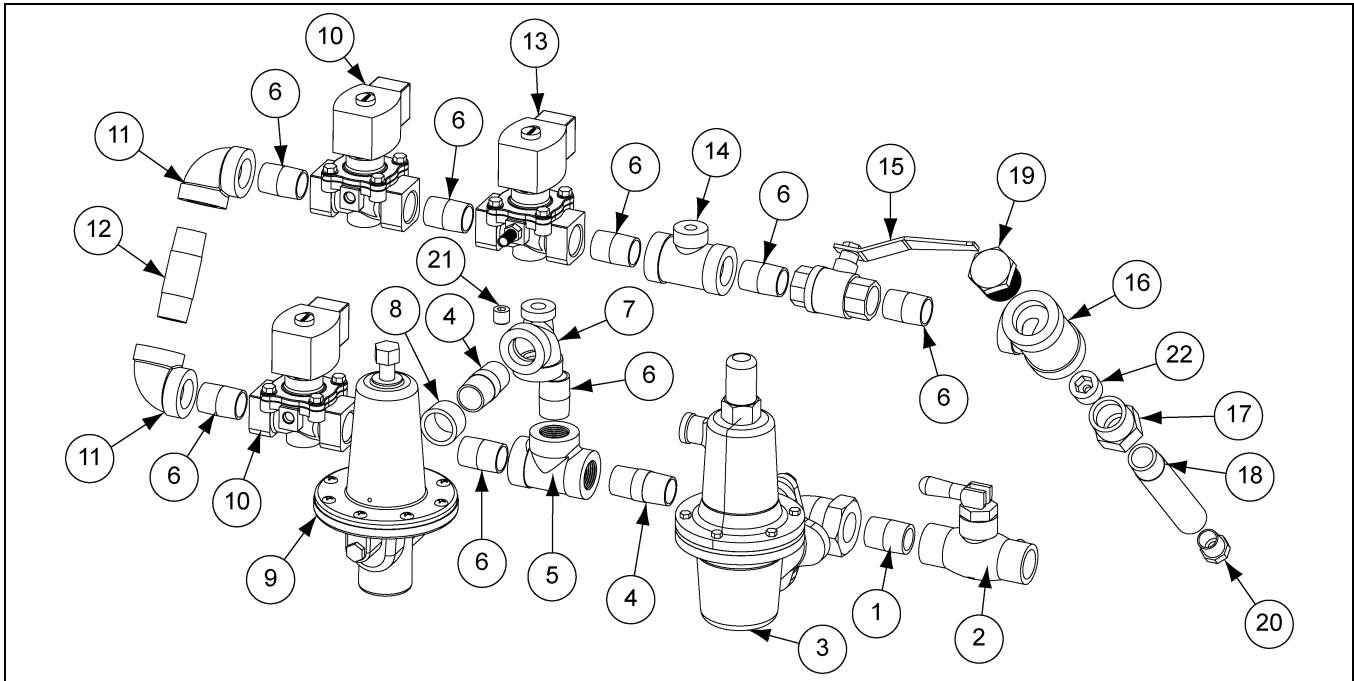

**24" and 28" Propane Vapor High-Low Pipe Train Assembly Parts List**

Ref #	Part #	Description	Qty	Unit
1	D67-0021	Nipple, 3/4" Close SCH 80 Black	1	All
2	D03-0841	Valve, 3/4" NPT LP Quick Shut Off CSA	1	All
3	D03-0880	Regulator, LP 5-20 PSI Spring, 0.5 Orifice, 3/4" NPT	1	All
4	THH-4125	Nipple, 3/4" x 2" SCH 40 Black	2	All
5	THH-4124	Tee, 3/4" x 3/4" x 3/4" SCH 40 Black	1	All
6	THH-4121	Nipple, 3/4" Close SCH 40 Black	8	All
7	THH-4158	Tee, 3/4" x 1/4" x 3/4" SCH 40 Black	1	All
8	007-1338-8	Bushing, Flush 1" to 3/4"	1	All
9	D03-0881	Valve, Relief - 15-50 PSI Spring LP, 1" NPT, 300F Rating	1	All
10	056-2223-8	Valve, Solenoid 3/4" NPT 115V Din 50 PSI	2	All
11	THH-4120	Elbow, 3/4"-90° SCH 40 Black	2	All
12	THH-4136	Nipple, 3/4" x 3" SCH 40 Black	1	All
13	056-2228-7	Valve, Solenoid 3/4" NPT 115V Din Bypass 30 PSI	1	All
14	THH-4154	Tee, 3/4" x 3/4" x 1/4" SCH 40 Black	1	All
15	D03-0837	Valve, 3/4" NPT Full Port, Lever, CSA, Brass or Bronze	1	All
16	D08-0017	Tee, 1" x 1" x 3/4" SCH 40 Black	1	All
17	HF-7794	Orifice Holder - Quad Heater - 3/4"	1	All
18	HH-7026	Orifice Pipe, 3/4" x 5-1/2"	1	All
19	D08-0014	Plug, 1" Square Black	1	All
20	HF-7126	Orifice (3/4) Drilled 3/8"	1	All
21	FLX-3788	Plug, 1/4" NPT Pipe	1	All
22	HF-7749	Orifice Plug (3/4) Drill: 17/64"	1	24"
22	HF-7809	Orifice Plug (3/4) Drill: 5/16"	1	28"

## 24" and 28" Vapor/NG High-Low Pipe Train Assembly

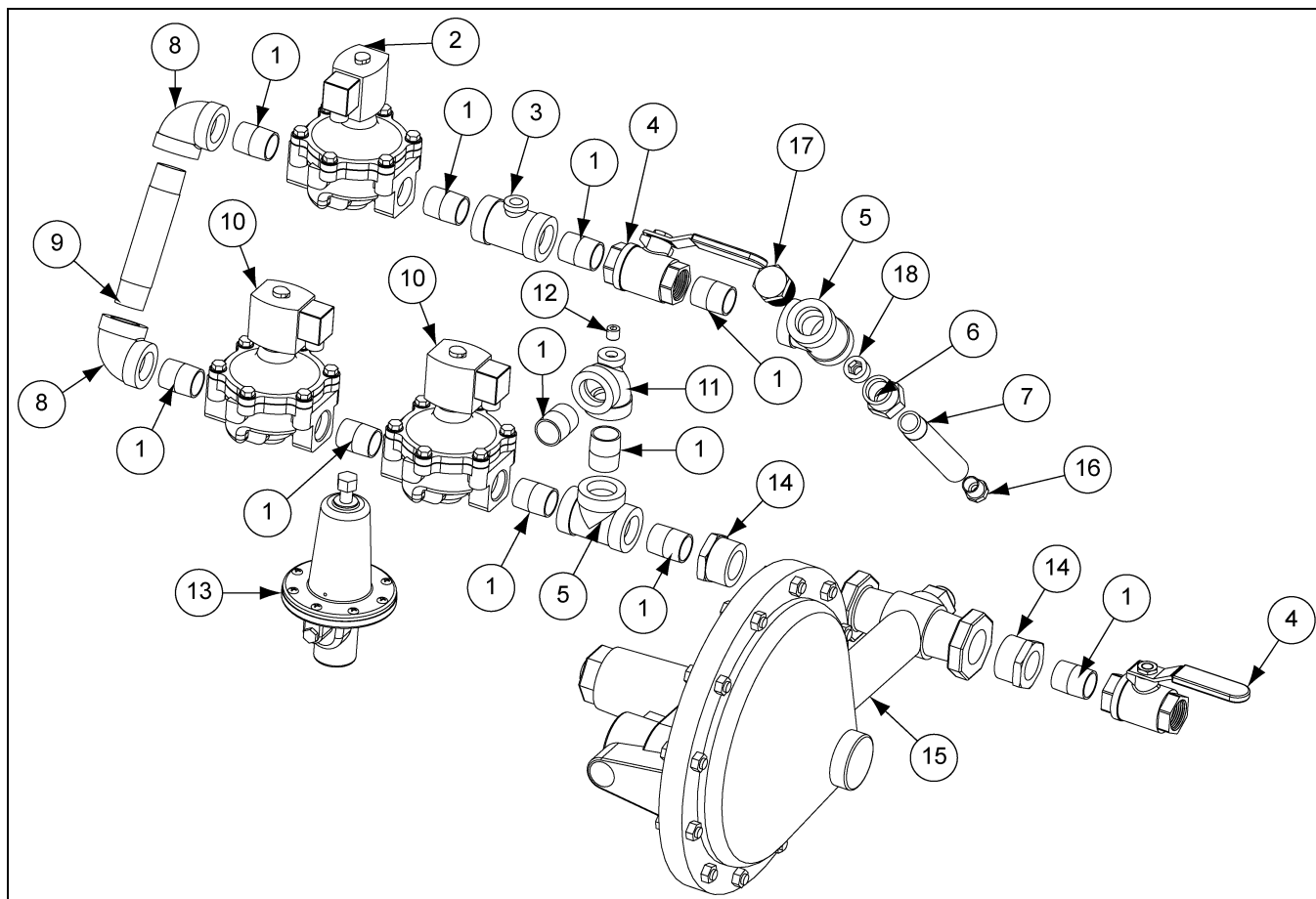

### 24" and 28" Vapor/NG High-Low Pipe Train Assembly Parts List

Ref #	Part #	Description	Qty	Diameter
1	THH-4117	Nipple, 1" Close SCH 40 Black	11	24" and 28"
2	056-2230-3	Valve, Solenoid 1" NPT 115V Din w/ Bypass	1	24" and 28"
3	THH-4152	Tee, 1" x 1" x 1/4" SCH 40 Black	1	24" and 28"
4	D03-0838	Valve, 1" NPT Full Port, Lever, CSA, Brass	2	24" and 28"
5	THH-4137	Tee, 1" x 1" x 1" SCH 40 Black	2	24" and 28"
6	HF-7794	Orifice Holder - Quad Heater - 3/4"	1	24" and 28"
7	HH-7027	Orifice Pipe, 3/4" x 6-1/2"	1	24" and 28"
8	THH-4115	Elbow, 1"-90° SCH 40 Black	2	24" and 28"
9	THH-4116	Nipple, 1" x 6" SCH 40 Black	1	24" and 28"
10	056-2224-6	Valve, Solenoid 1" NPT 115V Din	2	24" and 28"
11	THH-4163	Tee, 1" x 1/4" x 1" SCH 40 Black	1	24" and 28"
12	FLX-3788	Plug, 1/4" NPT Pipe	1	24" and 28"
13	D03-0881	Valve, Relief - 15-50 PSI Spring LP, 1" NPT, 300F Rating	1	24" and 28"
14	D08-0007	Reducer, 1-1/2" x 1" Hex Bushing	2	24" and 28"
15	D03-0819	Regulator, NG 4-10 PSI Spring, 1.19 Orifice, 1-1/2" NPT	1	24" and 28"
16	HF-7126	Orifice (3/4") Drilled 3/8"	1	24" and 28"
17	D08-0014	Plug, 1" Square Black	1	24" and 28"
18	406-2456-1	Orifice Plug, 3/4" NPT x 0.344"	1	24" NG
18	406-2441-3	Orifice Plug, 3/4" NPT x 0.406"	1	28" NG

## 10. Parts List

### LP Supply Pipe Train Assembly

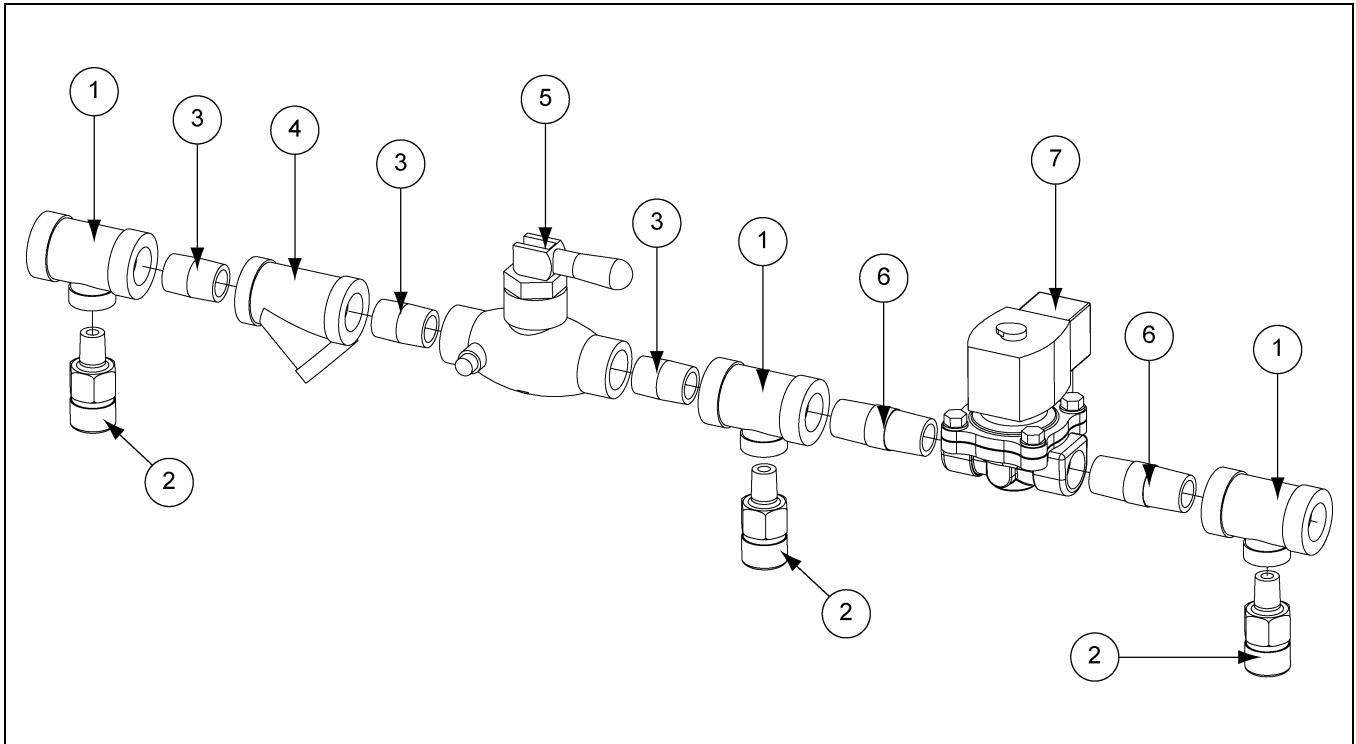

#### LP Supply Pipe Train Assembly Parts List

Ref #	Part #	Description	Qty
1	HH-4846	Tee, 1/2" x 1/2" x 1/4" SCH 80 Black	3
2	TFC-0027	Valve, 1/4" NPT 250# Relief	3
3	THH-4113	Nipple, 1/2" x Close SCH 80 Black	3
4	HH-1251	Strainer, 1/2" Y 250# WOG SCH 80	1
5	D03-0840	Valve, 1/2" NPT LP Quick Shut Off CSA	1
6	HF-7586	Nipple, 1/2" x 2" SCH 80 Black	2
7	TFC-0100	Valve, 1/2 NPT Solenoid LP w/ Din	1



## GSI Group, LLC Limited Warranty

The GSI Group, LLC ("GSI") warrants products which it manufactures to be free of defects in materials and workmanship under normal usage and conditions for a period of 12 months after sale to the original end-user or if a foreign sale, 14 months from arrival at port of discharge, whichever is earlier. The end-user's sole remedy (and GSI's only obligation) is to repair or replace, at GSI's option and expense, products that in GSI's judgment, contain a material defect in materials or workmanship. Expenses incurred by or on behalf of the end-user without prior written authorization from the GSI Warranty Group shall be the sole responsibility of the end-user.

### Warranty Extensions:

The Limited Warranty period is extended for the following products:

	Product	Warranty Period	
<b>AP Fans and Flooring</b>	Performer Series Direct Drive Fan Motor	3 Years	* Warranty prorated from list price: 0 to 3 years - no cost to end-user 3 to 5 years - end-user pays 25% 5 to 7 years - end-user pays 50% 7 to 10 years - end-user pays 75%
	All Fiberglass Housings	Lifetime	
	All Fiberglass Propellers	Lifetime	
<b>Cumberland Feeding/Watering Systems</b>	Feeder System Pan Assemblies	5 Years **	** Warranty prorated from list price: 0 to 3 years - no cost to end-user 3 to 5 years - end-user pays 50%
	Feed Tubes (1-3/4" and 2.00")	10 Years *	
	Centerless Augers	10 Years *	
	Watering Nipples	10 Years *	
<b>Grain Systems</b>	Grain Bin Structural Design	5 Years	
<b>Grain Systems Farm Fans Zimmerman</b>	Portable and Tower Dryers	2 Years	† Motors, burner components and moving parts not included. Portable dryer screens included. Tower dryer screens not included.
	Portable and Tower Dryer Frames and Internal Infrastructure †	5 Years	

GSI further warrants that the portable and tower dryer frame and basket, excluding all auger and auger drive components, shall be free from defects in materials for a period of time beginning on the twelfth (12<sup>th</sup>) month from the date of purchase and continuing until the sixtieth (60<sup>th</sup>) month from the date of purchase (extended warranty period). During the extended warranty period, GSI will replace the frame or basket components that prove to be defective under normal conditions of use without charge, excluding the labor, transportation, and/or shipping costs incurred in the performance of this extended warranty.

### Conditions and Limitations:

THERE ARE NO WARRANTIES THAT EXTEND BEYOND THE LIMITED WARRANTY DESCRIPTION SET FORTH ABOVE. SPECIFICALLY, GSI MAKES NO FURTHER WARRANTY OF ANY KIND, EXPRESS OR IMPLIED, INCLUDING, WITHOUT LIMITATION, WARRANTIES OF MERCHANTABILITY OR FITNESS FOR A PARTICULAR PURPOSE OR USE IN CONNECTION WITH: (I) PRODUCT MANUFACTURED OR SOLD BY GSI OR (II) ANY ADVICE, INSTRUCTION, RECOMMENDATION OR SUGGESTION PROVIDED BY AN AGENT, REPRESENTATIVE OR EMPLOYEE OF GSI REGARDING OR RELATED TO THE CONFIGURATION, INSTALLATION, LAYOUT, SUITABILITY FOR A PARTICULAR PURPOSE, OR DESIGN OF SUCH PRODUCTS.

GSI shall not be liable for any direct, indirect, incidental or consequential damages, including, without limitation, loss of anticipated profits or benefits. The sole and exclusive remedy is set forth in the Limited Warranty, which shall not exceed the amount paid for the product purchased. This warranty is not transferable and applies only to the original end-user. GSI shall have no obligation or responsibility for any representations or warranties made by or on behalf of any dealer, agent or distributor.

GSI assumes no responsibility for claims resulting from construction defects or unauthorized modifications to products which it manufactured. Modifications to products not specifically delineated in the manual accompanying the equipment at initial sale will void the Limited Warranty.

This Limited Warranty shall not extend to products or parts which have been damaged by negligent use, misuse, alteration, accident or which have been improperly/inadequately maintained. This Limited Warranty extends solely to products manufactured by GSI.

Prior to installation, the end-user has the responsibility to comply with federal, state and local codes which apply to the location and installation of products manufactured or sold by GSI.

This equipment shall be installed in accordance with the current installation codes and applicable regulations which should be carefully followed in all cases. Authorities having jurisdiction should be consulted before installations are made.

G S I G R O U P



**GSI Group**  
**1004 E. Illinois St.**  
**Assumption, IL 62510-0020**  
**Phone: 1-217-226-4421**  
**Fax: 1-217-226-4420**  
**[www.gsiag.com](http://www.gsiag.com)**