



ETL Listed Vane Axial Heater

Owner's Manual

PNEG-1775

Version: 5.0

Date: 11-30-17



Intertek



PNEG-1775

Models

VHC; followed by -18, -24 or -28; followed by -NGC, -NGH, -VPC, -VPH, -LPC or -LPH

Heater Check List

1. All wire connections
2. Spark plug gap 0.125
3. Pipe train tightness and gas leaks
4. Flame sensor tight
5. Fuse in place, extra fuse provided
6. Indicator light
7. Pressure gauge
8. Regulator adjusted
9. Shut off valve operates correctly
10. Vapor high-limit
11. Unit cycles ON to OFF
12. Heat rise even across transition
13. Unit cycles high to low (high-low only)
14. All decals and serial number tag
15. Aesthetic appearance
16. Manual

Tester Signature: _____

Date: _____

The equipment shall be installed in accordance with the **Natural Gas and Propane Installation Code, CSA B149.1 and the Propane Storage and Handling Code, CSA B149.2** or applicable provincial regulations, which should be carefully followed in all cases. Authorities having jurisdiction should be consulted before installations are made.

Contents

Chapter 1 Safety	5
Safety Guidelines	5
Cautionary Symbols Definitions	6
Safety Cautions	7
Safety Sign-Off Sheet	11
Chapter 2 Safety Decals	12
Fan/Heater Decals	12
Heater Access Door Decals	13
Control Box Decals	14
Chapter 3 Installation	15
Machine to Earth Ground	15
Previously Installed Units	15
Fuel Connection	15
Liquid Propane Models	16
Propane Vapor Models	16
Natural Gas Models	16
Heater Specifications	17
CSA Heater Electrical Installation	18
Standard Heater - Second Heater Installation	19
Bin Configuration	20
Plenum Thermostat Transition High-Limit Installation	21
Plenum Thermostat Mounting	21
Heater Orifice Setup	22
Chapter 4 Operation	23
Operating Temperature Table	23
Cycling Heater Operation	23
High-Low Heater Operation	24
Adjusting the Vaporizer	25
BTUs for Gauge Pressure (PSI) Reading Propane Models (Approximate)	26
BTUs for Gauge Pressure (PSI) Reading Natural Gas Models (Approximate)	27
Chapter 5 Service	28
Seasonal Inspection and Service	28
Internal (Seat) Leakage Testing for Safety Shut Off Valves	29
Chapter 6 Troubleshooting - Heater	31
Chapter 7 Wiring Diagrams	32
CSA (LP, High-Low) Heater Wiring Diagram	32
Ladder Logic Control for LP, High-Low CSA Heater	33
CSA (LP, Non-High-Low) Heater Wiring Diagram	34
Ladder Logic Control for LP, Non-High-Low CSA Heater	35
CSA (NG, High-Low) Heater Wiring Diagram	36
Ladder Logic Control for NG, High-Low CSA Heater	37
CSA (NG, Non-High-Low) Heater Wiring Diagram	38
Ladder Logic Control for NG, Non-High-Low CSA Heater	39
CSA Heater Operation Flow Chart	40

Table of Contents

Chapter 8 Parts List	41
CSA VA Heater Control Box Sub-Assembly (HF-8453)	42
18", 24" and 28" Gas Heater Parts	44
CSA 18" Vane Axial Propane Pipe Train Sub-Assembly (HF-8216)	46
CSA Vane Axial Propane Pipe Train Cycling (HF-8378)	47
CSA Vane Axial Propane High-Low Pipe Train (HF-8379)	48
CSA 24" Propane Vapor Pipe Train Sub-Assembly (HF-8217)	49
CSA 28" Vane Axial LP Pipe Train Sub-Assembly (HF-8201)	50
CSA 24" Propane Vapor LP High-Low Pipe Train Sub-Assembly (HF-8218)	51
CSA 28" Propane Vapor LP High-Low Pipe Train Sub-Assembly (HF-8220)	52
CSA Vapor/NG High-Low Pipe Train Assembly (HF-8381)	53
CSA Vapor/NG Pipe Train Cycling (HF-8380)	54
CSA LP Supply Pipe Train Sub-Assembly (HF-8203)	55
Chapter 9 Warranty	57

Safety Guidelines

Safety guidelines are general-to-specific safety rules that must be followed at all times. This manual is written to help you understand safe operating procedures and problems that can be encountered by the operator and other personnel when using this equipment. Save these safety guidelines for future reference.

As owner or operator, you are responsible for understanding the requirements, hazards, and precautions that exist and to inform others as required. Unqualified persons must stay out of the work area at all times.

Alterations must not be made to the equipment. Alterations can produce dangerous situations resulting in **SERIOUS INJURY** or **DEATH**.

This equipment must be installed in accordance with the current installation codes and applicable regulations, which must be carefully followed in all cases. Authorities having jurisdiction must be consulted before installations are made.

When necessary, you must consider the installation location relative to electrical, fuel and water utilities.

Personnel operating or working around equipment must read this manual. This manual must be delivered with equipment to its owner. Failure to read this manual and its safety instructions is a misuse of the equipment.

ST-0001-3

Cautionary Symbols Definitions

Cautionary symbols appear in this manual and on product decals. The symbols alert the user of potential safety hazards, prohibited activities and mandatory actions. To help you recognize this information, we use the symbols that are defined below.



This symbol indicates an imminently hazardous situation which, if not avoided, **will result in serious injury or death.**



This symbol indicates a potentially hazardous situation which, if not avoided, **can result in serious injury or death.**



This symbol indicates a potentially hazardous situation which, if not avoided, **can result in minor or moderate injury.**



This symbol is used to address practices not related to personal injury.



This symbol indicates a general hazard.



This symbol indicates a prohibited activity.

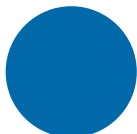

This symbol indicates a mandatory action.

ST-0005-2

Safety Cautions

Use Personal Protective Equipment

- Use appropriate personal protective equipment:

Eye Protection



Respiratory Protection



Foot Protection



Hearing Protection



Head Protection



Fall Protection



Hand Protection



- Wear clothing appropriate to the job.
- Remove all jewelry.
- Tie long hair up and back.

ST-0004-1

Follow Safety Instructions

- Warning:** If the information in the manual is not followed exactly, a fire or explosion can result, causing property damage, personal injury or loss of life.
- Carefully read all safety messages in this manual and safety signs on your machine. Keep signs in good condition. Replace missing or damaged safety signs. Be sure new equipment components and repair parts include the current safety signs. Replacement safety signs are available from the manufacturer.
- Learn how to operate the machine and how to use controls properly. Do not let anyone operate without instruction.
- If you do not understand any part of this manual or need assistance, contact your dealer.
- Retain these instructions for future reference.



ST-0025-3

1. Safety

For Your Safety

- If you smell gas:
 - Do not try to light any appliance.
 - Extinguish any open flames.
 - Do not touch any electrical switch.
 - Immediately call your gas supplier. Follow the gas supplier's instructions.
 - If you cannot reach your gas supplier, call the fire department.
- The use and storage of gasoline and other flammable vapors and liquids in open containers in the vicinity of this appliance is hazardous.
- Improper installation, adjustment, alteration, service or maintenance can cause property damage, injury or death. Read the installation, operating and maintenance instructions thoroughly before installing or servicing this equipment. Installation and service must be performed by a qualified installer, service agency or the gas supplier.



ST-0024-1

Maintain Equipment and Work Area

- Understand service procedures before doing work.
- Keep area clean and dry.
- Do not service equipment while it is operating. Disconnect and lock-out power and fuel supply before entering equipment or before performing maintenance.
- Keep your equipment in proper working condition. Replace worn or broken parts immediately.
- Depressurize the fuel train before disassembling for service.
- Allow the fan to operate for 20 minutes with the burner off to purge products of combustion and to cool the components before entering.
- Check regularly for any developing gas plumbing leaks. Do not operate the dryer if any gas leak is detected. Shut down and repair before further operation.



ST-0030-2

Handle and Use Equipment Properly

- Equipment is intended for the use of grain drying only. Any other use is a misuse of this equipment.
- The operating instructions in this manual pertain to the common cereal grains as indicated. When drying any other grain, contact GSI for additional recommendations.
- On LP fired units, set pressure regulator to avoid excessive gas pressure applied to the burner during ignition and operation. Do not exceed maximum recommended drying temperatures.
- Equipment has sharp edges that may cause serious injury. To avoid injury, handle sharp edges with caution and use proper protective clothing and equipment at all times.
- All guards must be in place before and during operation. Images of guards removed in this manual are for illustration purposes only.
- Use caution when working around high-speed fans, gas burners, augers and auxiliary conveyors which can start automatically.
- Keep hands, feet, and clothing away from moving parts.
- Do not bypass any safety device or interlock.
- Do not enter the dryer or bin while it is operating.
- Do not operate in an area where combustible material will be drawn into the dryer.



ST-0029-2

Install and Operate Electrical Equipment Properly

- Electrical controls must be installed by a qualified electrician and must meet the standards set by the National Electric Code, Canadian Electrical Code, and all local and state codes.
- Lock-out power source before making adjustments, cleaning, or maintaining equipment.
- Heater must be interlocked with an appropriately sized fan and a thermostat must be installed for safe operation.



ST-0026-2

1. Safety

Prevent Roof Damage Due to Vacuum Pressure

- Roof damage can result from excessive vacuum or internal pressure from fans or other air moving systems. The manufacturer does not warrant this type of roof damage.
- Adequate ventilation or “makeup air” devices must be provided for all powered air handling systems.
- The manufacturer does not recommend the use of downward flow systems (suction).
- Severe roof damage can result from any blockage of air passages.
- Operating fans during high humidity or cold weather conditions can cause air exhaust or intake ports to freeze.

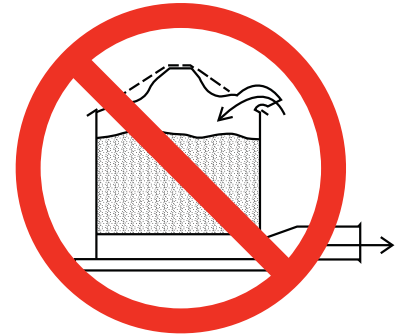

ST-0028-2

Exercise Caution When Drying Flammable Grains

- Be aware that some grains are highly flammable including but not limited to, rapeseed, canola, linseed, sunflower and milo.
- All grain and seed must be whole (minimal cracking or crushing), clean and, dust free before drying.
- Avoid dust and chaff from being drawn into the fan and heater.
- To reduce risk of fire, keep the fan, heater, drying plenum and ducts clean at all times.
- In the event of a fire (or suspected fire):
 1. Shut down the entire dryer.
 2. Turn off fuel at the tank or supply valve.
 3. Shut off and lock electrical power.
 4. Evacuate the area.
 5. Call the fire department.



ST-0032-1

2. Safety Decals







The safety decals on your equipment are safety indicators which must be carefully read and understood by all personnel involved in the installation, operation, service and maintenance of the equipment.

To replace a damaged or missing decal, contact us to receive a free replacement.



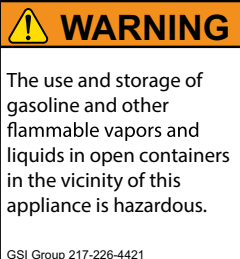

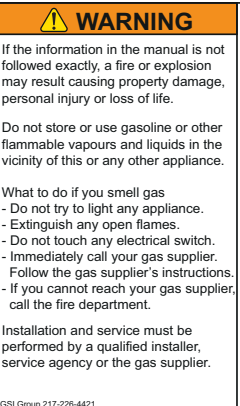
GSI Decals

1004 E. Illinois St.
Assumption, IL 62510
Tel: 1-217-226-4421

Fan/Heater Decals

Location	Decal No.	Decals	Description
Fan/Heater unit	DC-2330	 	Read manual warning decal
Fan/Heater unit	DC-2331	 	Flammable vapor warning decal
Fan/Heater unit	DC-2392	 	Flammable vapor warning decal

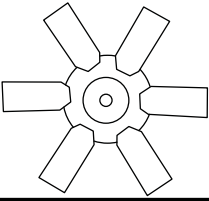
Heater Access Door Decals

Location	Decal No.	Decals	Description
<p>Above Access Door on Heater Housing</p>	<p>DC-1949</p>	<div style="display: flex; justify-content: space-between;"> <div style="width: 30%; border: 1px solid black; padding: 5px;"> <p>⚠ WARNING</p> <p>Stay clear of rotating blade. Blade could start automatically. Can cause serious injury. Disconnect power before servicing.</p> <p><small>GSI Group Inc. 217-226-4421</small></p> </div> <div style="width: 30%; text-align: center;">  </div> <div style="width: 30%; border: 1px solid black; padding: 5px;"> <p>⚠ AVERTISSEMENT</p> <p>Restez éloigné de la lame tournante. La lame peut se mettre en marche automatiquement. Peut causer de sérieuses blessures. Vérifiez le courant avant l'entretien.</p> <p><small>DC-1949</small></p> </div> </div>	<p>Warning Rotating Blade, CE, CSA Harmonized</p>
<p>Above Access Door on Heater Housing</p>	<p>DC-1959</p>	<div style="display: flex; justify-content: space-between;"> <div style="width: 30%; border: 1px solid black; padding: 5px;"> <p>⚠ WARNING</p> <p>Flame and pressure beyond door can cause serious injury. Do not operate with service door removed. Keep head and hands clear.</p> <p><small>GSI Group Inc. 217-226-4421</small></p> </div> <div style="width: 30%; text-align: center;">  </div> <div style="width: 30%; border: 1px solid black; padding: 5px;"> <p>⚠ AVERTISSEMENT</p> <p>La flamme et la pression au-delà de la porte peuvent causer des dommages sérieux. Ne pas faire fonctionner si la porte de service est enlevée. Gardez les mains et la tête éloignés.</p> <p><small>DC-1959</small></p> </div> </div>	<p>Warning Fire (Small), CE, CSA Harmonized</p>
<p>Above Access Door on Heater Housing</p>	<p>DC-1971</p>	<div style="display: flex; justify-content: space-between; align-items: center;"> <div style="width: 30%; text-align: center;"> <p>AIRFLOW</p>  <p>AIRFLOW</p> </div> <div style="width: 30%; text-align: center;">  </div> <div style="width: 30%; text-align: center;"> <p>CIRCULATION D'AIR</p>  <p>CIRCULATION D'AIR</p> <p><small>DC-1971</small></p> </div> </div>	<p>Air Flow, CE, CSA Harmonized</p>

2. Safety Decals

Control Box Decals

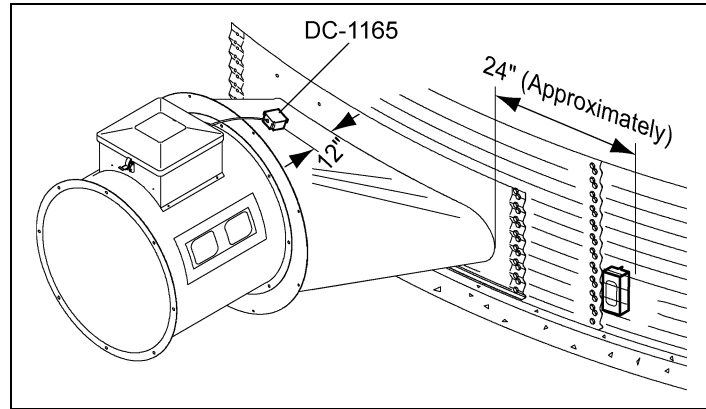

Location	Decal No.	Decals	Description
Control Box	DC-1948		Decal, Danger High-Voltage (LG), CE, CSA Harmonized
Control Box	DC-535		Decal, 24"-28" Vaporizer Adjustment
Control Box	DC-1165		Decal, Danger Transition High-Limit
Control Box	DC-1702		Decal, Caution Use TSTAT with Heater

Machine to Earth Ground

It is very important that a machine to earth ground rod be installed at the fan. This is true even if there is a ground at the pole 15' away. This ground needs to be as close to the fan as possible, but no more than 8' away. The ground rod should be connected to the fan control panel with at least a #6 solid bare copper ground wire or in accordance with local requirements. The machine to earth ground provides additional safety if there is a short. It also provides the grounding necessary for long life and operation of the solid state circuit boards used on control circuits and the electronic ignition systems.

Previously Installed Units

It is recommended that previously installed units be checked to see that a machine to earth ground has been installed by an electrician.

Standard electrical safety practices and codes should be used when working with a heater. Refer to the National Electric Code Standard Handbook by the National Fire Protection Association. *A qualified electrician should make all wiring installations.*



Always disconnect and lock out power before working on or around heater.

Fuel Connection

IMPORTANT: *Do not use propane tanks that have previously been used for ammonia unless they have been purged according to procedures of the National LP association.*

Fuel supply system must comply with local codes for LP gas installation.

Dryer/heater and individual shut off valve must be disconnected from the gas supply piping system during any pressure testing of the system at test pressures in excess of 1/2 PSI. The dryer/heater must be isolated from the gas supply piping by closing its individual manual shut off valve during any pressure testing of the gas supply piping system at test pressures equal to or less than 1/2 PSI.

Refer to the dryer/heater rating plate for determining the minimum gas supply pressure for obtaining the maximum gas capacity for which this dryer is specified.

The equipment shall be installed in accordance with the Natural Gas and Propane Installation Code, CSA B149.1 and the Propane Storage and Handling Code, CSA B149.2 or applicable provincial regulations, which should be carefully followed in all cases. Authorities having jurisdiction should be consulted before installations are made. Bleeds and vents that require venting by authorities having jurisdiction shall be vented away from any sources of ignition by the gas piping installer. The installer shall also locate a manual emergency shut off valve in an appropriate location that allows access to the valve to shut off the fuel to the dryer in case of a fire or explosion at the dryer.

3. Installation

Liquid Propane Models

1. LP models are designed to run on liquid propane, with liquid draw from the propane tank. Avoid using propane supply tanks that have been use for vapor draw for long periods of time. When using liquid draw systems any moisture that may be present in tank or lines may freeze when system is used in cold weather. To avoid this, the usual precaution is to purge the system with methanol.
2. Run proper size line ([See Specifications on Page 17](#)) to pipe train on heater. Have a qualified gas service person inspect installation to be sure everything is installed according to local codes and ordinances.
3. After installation is complete check all connections for leaks. Use liquid detergent or comparable substance. Wear rubber gloves and eye protection. Avoid contact with liquid propane. **DO NOT USE FLAME FOR LEAK TESTING.**

Propane Vapor Models

1. Propane vapor models are designed to run directly off of supply tank or from a separate external vaporizer.
2. Run proper size line ([See Specifications on Page 17](#)) to pipe train on heater. Have a qualified gas service person inspect installation to be sure everything is installed according to local codes and ordinances.
3. After installation is complete check all connections for leaks. **DO NOT USE FLAME FOR LEAK TESTING.**

Natural Gas Models

1. Natural gas models are similar to vapor models, but have a larger orifice to accommodate lower pressure, sometimes found with natural gas.
2. Run proper size line ([See Specifications on Page 17](#)) to pipe train on heater. Have a qualified gas service person inspect installation to be sure everything is installed according to local codes and ordinances.
3. After installation is complete check all connections for leaks. **DO NOT USE FLAME FOR LEAK TESTING.**

Heater Specifications

		18"	24"	28"
All Models	Inside Diameter	18-5/16"	24-1/4"	28-1/8"
	Bole Circle Diameter	19-7/16"	25-3/4"	29-5/8"
	Length	22"	22-1/2"	25-1/4"
	High Temp BTU Rating	1,400,000	2,100,000	3,000,000
	Low Temp BTU Rating	400,000	500,000	500,000
High Temperature Liquid Propane	Maximum Fuel Flow (GPH)	N/A	23	34
	Orifice	N/A	15/64	9/32
	Operating Pressure Range	N/A	2-20	2-20
	Min Line Size	N/A	3/8"	3/8"
High Temperature Natural Gas	Maximum Fuel Flow (CFH)	1473	2210	3157
	Orifice	17/64	5/16	3/8
	Operating Pressure Range	1-7	1-7	1-7
	Min Line Size	1"	1-1/4"	1-1/4"
Low Temperature Liquid Propane	Maximum Fuel Flow (GPH)	N/A	6	6
	Orifice	N/A	5/32	5/32
	Operating Pressure Range	N/A	2-20	2-20
	Min Line Size	N/A	1/4"	1/4"
Low Temperature Natural Gas	Maximum Fuel Flow (CFH)	421	736	736
	Orifice	9/64	3/32	3/32
	Operating Pressure Range	1-7	1-7	1-7
	Min Line Size	1/2"	1/2"	1/2"

3. Installation

CSA Heater Electrical Installation



Always disconnect and lock out power before working on or around heater.

Standard electrical safety practices and codes should be used when working with a heater. Refer to the National Electric Code Standard Handbook by the National Fire Protection Association. A *qualified electrician* should make all wiring installations.

IMPORTANT: Heater must be interlocked with fan for safe operation.

Heater Power Connection

1. Connect power cord to fan control box.
2. Make field connections in fan box as shown in [Figure 3A](#).
3. Connect deluxe thermostat control as shown in [Figure 3A](#).

IMPORTANT: Thermostat must be installed for safe operation.

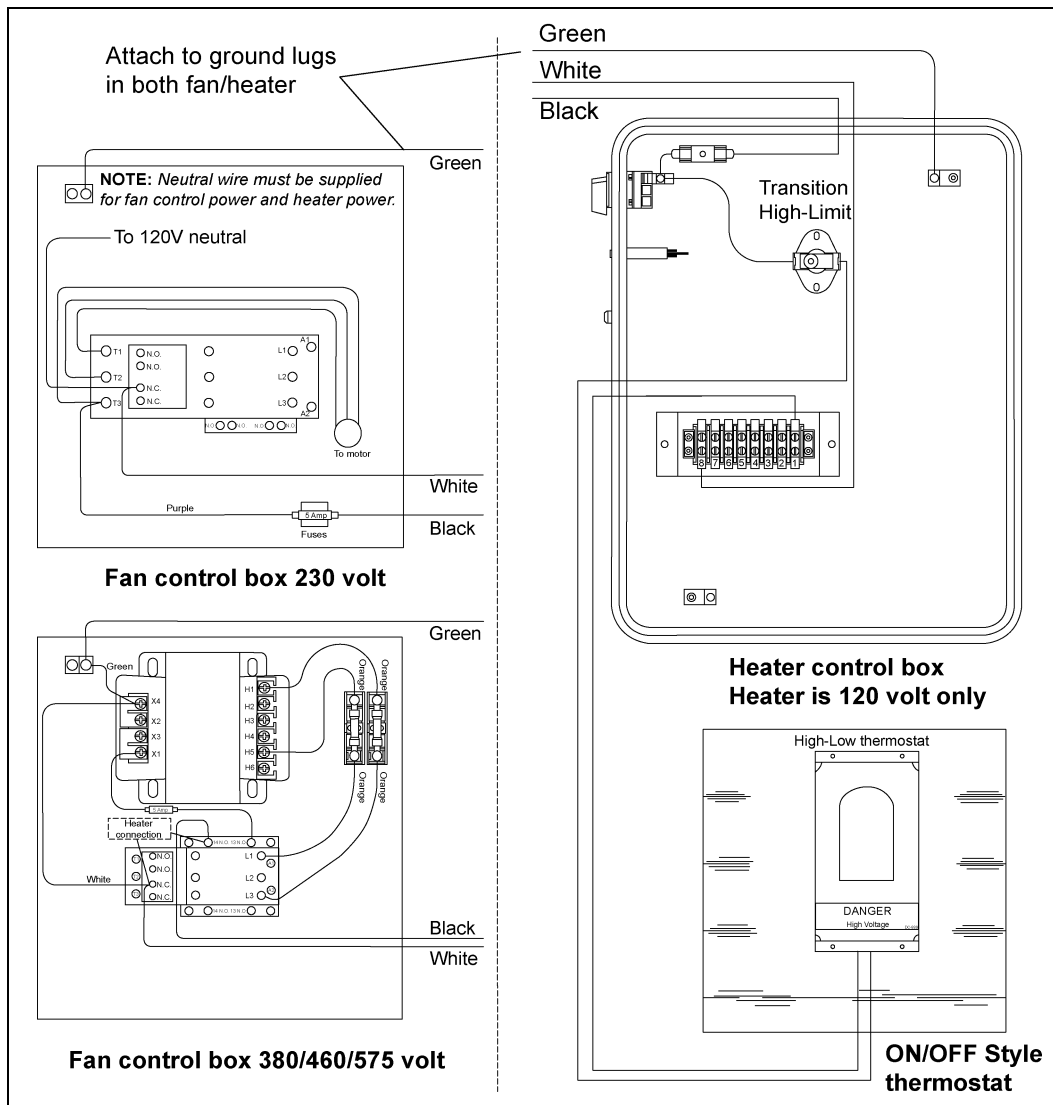

Figure 3A Heater Wiring Installation on a Fan Unit

Standard Heater - Second Heater Installation

Two (2) standard heaters may be connected to one grain drying system and wired so they cycle together. One of the heaters should have a thermostat connected to it as per the installation instructions. That heater will be referred to as the primary. The other heater (without the thermostat) will be referred to as the secondary.

1. Install relay base (TD-100283) in primary heater control box.
2. Connect wire between terminal 13 on relay base to terminal 5 on terminal strip in primary heater.
3. Connect wire between terminal 14 on relay base to terminal 6 on terminal strip in primary heater.
4. Run two (2) wires (18 gauge) between primary and secondary heater.
5. Connect wires to terminals 5 and 9 (points A and B) on relay base in primary heater.
6. Connect wire from terminal 9 in primary to (point F) in secondary unit.
7. Connect wire from terminal 5 in primary to (point G) in secondary unit.
8. Install relay (TD-100282) in relay base.

Follow these additional steps for HIGH-LOW units.

1. Install relay base (TD-100283) in master heater control box.
2. Connect wire between terminal 13 on relay base to green wire from HIGH-LOW thermostat in master unit. Do not disconnect other wires from green wire 3. Connect wire between terminal 14 on relay base to terminal 14 on other relay base in master heater.
3. Run two (2) wires (18 gauge) between master and slave heater.
4. Connect wires to terminals 5 and 9 (points A and B) on relay base in master heater.
5. Connect wire from terminal 9 in master to terminal 6 (point G) in slave unit.
6. Connect wire from terminal 5 in master to cycle solenoid and red light in slave unit. Do not connect wire to side of cycle solenoid and light that are connected to terminal.

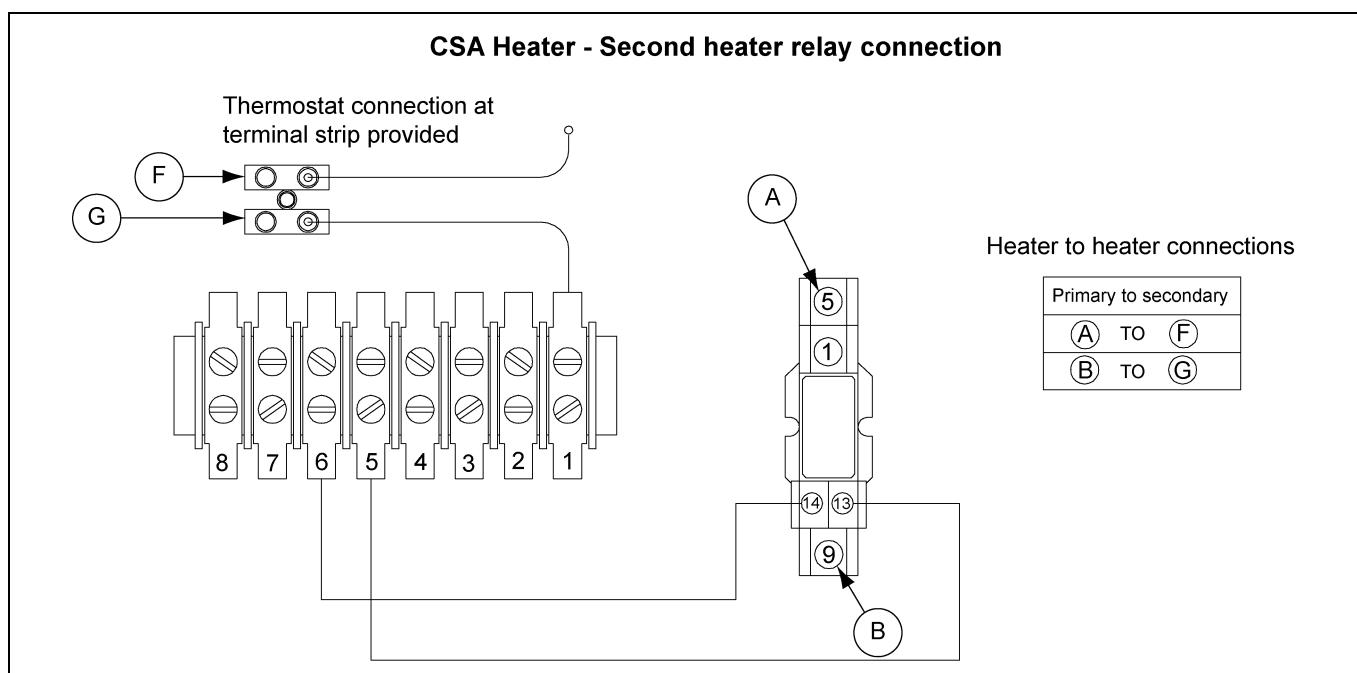

Figure 3B CSA Heater - Second Heater Relay Connection

Bin Configuration

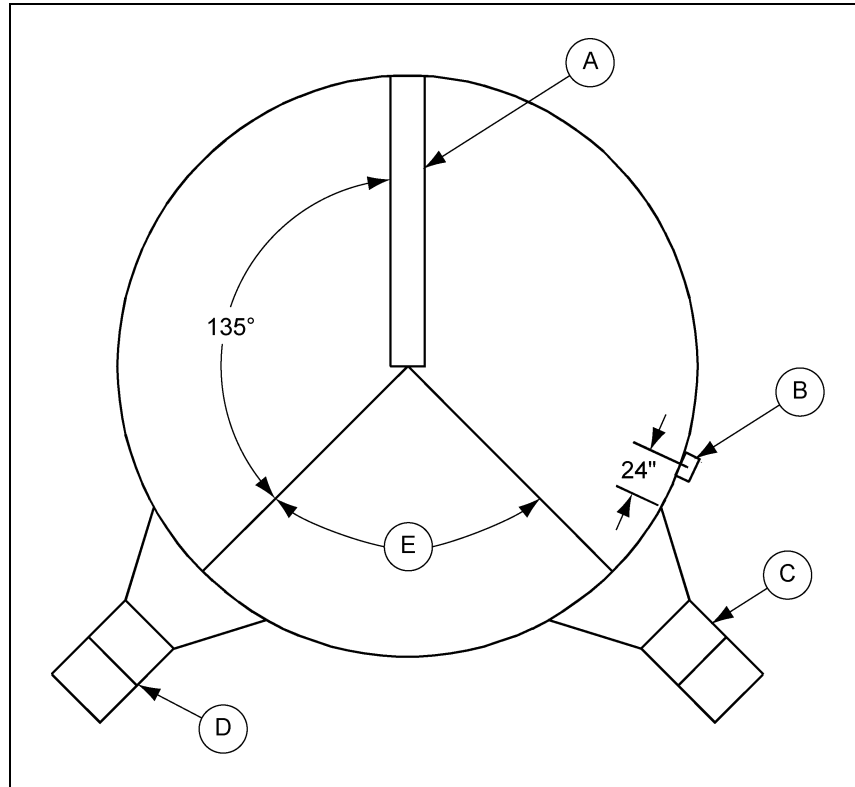

Figure 3C

Ref #	Description
A	Unload Auger
B	Plenum Thermostat
C	Master Heater
D	Slave Heater
E	90° or Less

IMPORTANT: When mounting two (2) heaters on a bin it is imperative that they be situated as shown in [Figure 3C](#). Plenum thermostat must be to the right of master heater and master heater must be to the right of slave heater.

Plenum Thermostat Transition High-Limit Installation

1. Mark location on transition one foot up from the bottom (entrance collar) and centered in the transition.
2. Drill or knock out 7/8" diameter hole on marked location.
3. Install transition high-limit using supplied self-drilling screws.

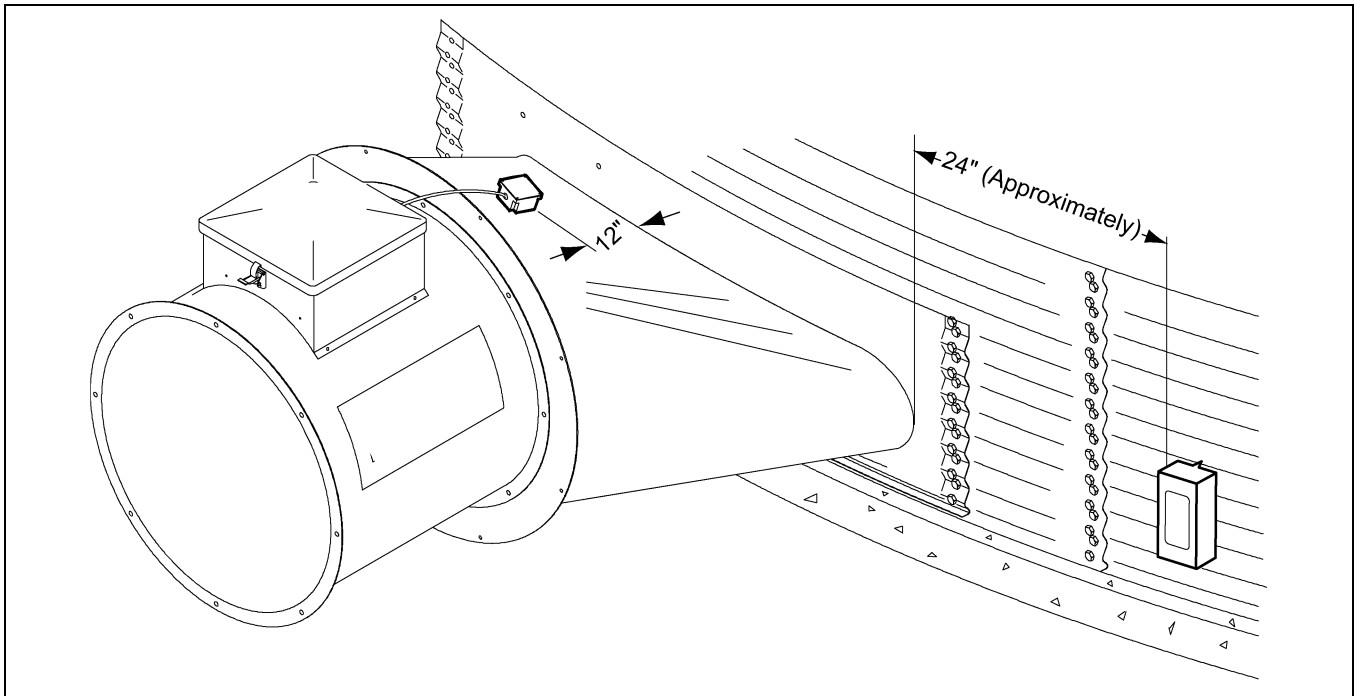

Figure 3D The transition connecting the Vane Axial Heater to the bin with the plenum sensor in place.

Plenum Thermostat Mounting

The plenum thermostat must be ordered separately from the heater unit.

1. Follow installation instructions provided with the thermostat assembly.
2. Position the housing so that the bolt flanges are vertical and the cord exits the housing from the bottom. Mark position.
3. Use self-drilling screws to mount the housing to the bin sidewall. **DO NOT TIGHTEN COMPLETELY.** Insert corrugation seal into gap between housing and sidewall. Tighten screws.
4. Caulk between the housing and the sidewall to seal.



Thermostat must be installed to operate as plenum high-limit safety.

Heater control device (thermostat or humidistat) is required for heater warranty on all heaters.

3. Installation

Heater Orifice Setup

The factory has set the orifices size for propane, high temperature and natural gas, low temperature.

1. Determine the type of gas to be used: Propane or natural gas.
2. Determine the operating temperature ranges to be used: High or low. Refer to tables on [Page 26](#) and [Page 27](#).
3. For natural gas high temperature applications remove reducer bushing with pressure gauge and remove primary orifice from system. Replace reducer bushing and check connections for leaks. For natural gas high temperature configuration there is no primary orifice in the system. Refer to [Fuel - Temperature Table below](#).
4. For propane low temperature applications remove reducer bushing with pressure gauge and replace the supplied primary orifice with orifice supplied in control box. Replace reducer bushing and check connections for leaks. Refer to [Fuel - Temperature Table below](#).

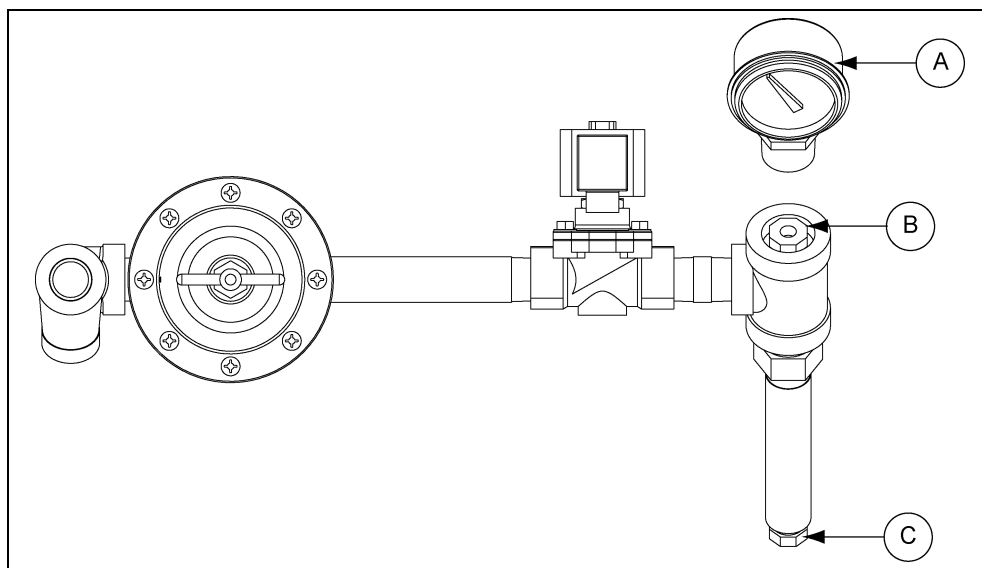

Figure 3E

Ref #	Description
A	Reducer Bushing with Pressure Gauge
B	Primary Orifice
C	3/8" Secondary Orifice

Fuel - Temperature

Fuel	Temperature	
	High	Low
Natural Gas	Remove primary orifice completely.	No modifications required. Standard with 7/32" orifice.
Propane	No modifications required. Standard with 7/32" orifice.	Replace primary orifice with 3/32" orifice supplied in control box.



Make sure the configuration matches the appropriate application in the [Fuel - Temperature Table above](#). Propane has a higher BTU content than natural gas. Do not remove 3/8" secondary orifice. Excessive heat rise due to improper orifice sizing or removing the 3/8" secondary orifice will damage grain or cause fire.

Operating Temperature Table

IMPORTANT: *The **below table** is not intended as a drying guide. It should be used as a reference for setting maximum plenum temperature for safe operation.*



*Do not exceed plenum temperatures listed in **table below**.*

	Low Temperature Batch	High Temperature Batch Dry No Stirring	High Temperature with Stirring	Continuous Flow (Recirculating)
Corn	5°-20° above Ambient Temperature	120°	140°	160°
Rice	5°-10° above Ambient Temperature	100°	100°	Not Recommended
Beans and Wheat	5°-20° above Ambient Temperature	110°	120°	Not Recommended

Cycling Heater Operation

1. Thermostat must be wired into heater control box for heater to operate.
2. Open all manual shut off valves to heater unit.
3. Start fan. This will supply power to heater.
4. Turn thermostat dial to its highest setting.
5. Turn toggle switch ON.
6. Heater will light after purge. If heater fails to light check to see that all gas is ON.
7. Watch thermometer on plenum and when it reaches desired temperature turn thermostat back slowly until heater cycles OFF.
8. Gas pressure should be adjusted so burner is ON 75% of the time.
9. Watch plenum temperature as burner goes through a few cycles, to be sure that it is operating properly.

4. Operation

High-Low Heater Operation

1. High-Limit and cycling thermostat must be wired into heater control box for heater to operate.
2. Open all manual shut off valves to heater unit.
3. Start fan. This will supply power to heater.
4. Turn thermostat dial to its highest setting.
5. Turn toggle switch ON. Both lights should illuminate indicating power to the control circuit.
6. Heater will light after purge. If heater fails to light check to see that all gas is ON.
7. Open adjustment screw on solenoid valve all the way.
8. Turn thermostat dial back slowly until heater cycles to low flame.
9. Adjust screw on solenoid valve so that low flame pressure is at desired setting. (As low as possible.)
10. Turn thermostat dial to desired setting and wait for bin plenum to come up to temperature. Heater should cycle to low flame after a few minute.
11. If heater does not cycle to low flame increase high flame gas pressure by adjusting the regulator.
12. High flame should be adjusted so the heater cycles 75% of the time. Low flame should be adjusted so there is enough flame for unit to keep operating.
13. Watch as burner goes through a few cycles, to be sure that it is operating properly back to high flame.

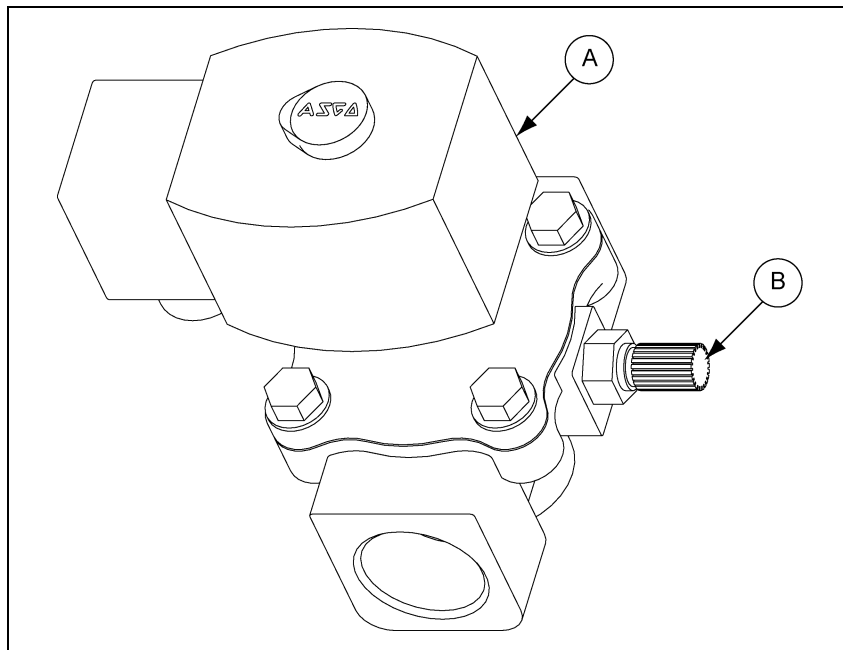

Figure 4A

Ref #	Description
A	High-Low Valve
B	High-Low Valve Adjustment Screw

Adjusting the Vaporizer

1. Vaporizer should be adjusted so the vapor pipe train runs warm to the touch (100°-120°F).
2. Loosen 5/16" pivot bolts on adjustment bracket.
3. Tilt vaporizer away from burner to cool. Tilt toward burner to heat. Vaporizer may be raised or lowered for vertical adjustments.
4. Tighten 5/16" pivot bolts to fix vaporizer position.

IMPORTANT: Only move vaporizer 1" at a time. Allow heater to run a few minutes for temperature to equalize.

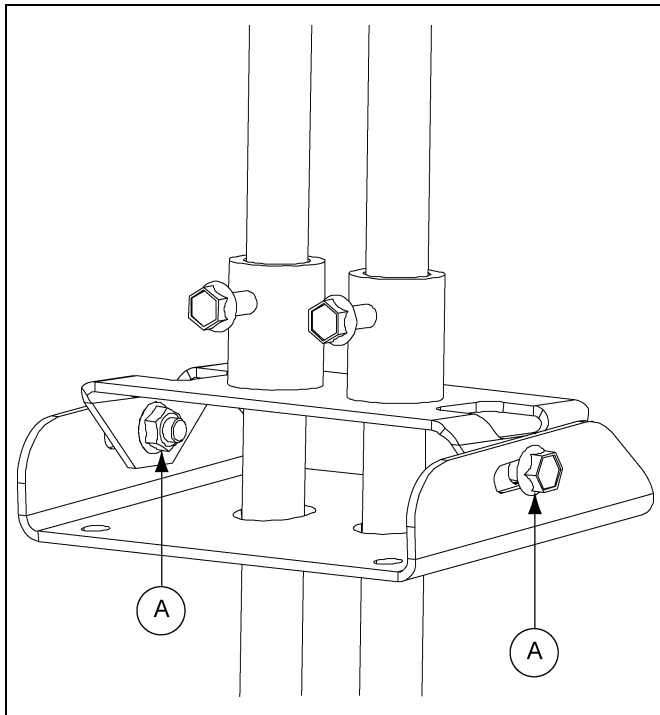

Figure 4B

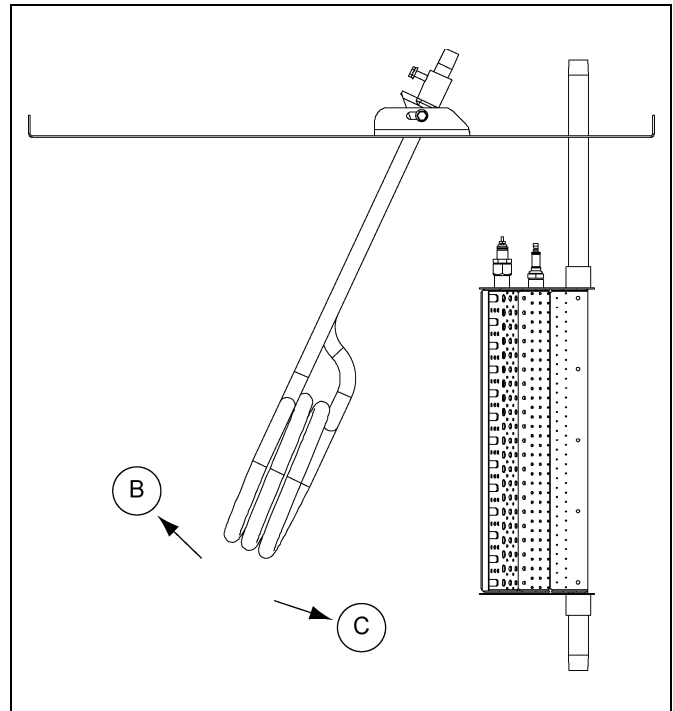

Figure 4C

Ref #	Description
A	Pivot Bolts
B	Cooler
C	Warmer

Vaporizer adjustment: Away from burner to cool. Toward burner to heat.

4. Operation

BTUs for Gauge Pressure (PSI) Reading Propane Models (Approximate)

High Temperature

Diameter	Operating Pressure (PSI)									
	2	4	6	8	10	12	14	16	18	20
24"	1,821,128	2,487,296	3,054,193	3,539,643	3,960,025	4,330,275	4,663,886	4,972,904	5,267,934	5,558,136
28"	2,622,425	3,581,706	4,398,038	5,097,085	5,702,436	6,235,596	6,715,995	7,160,981	7,585,825	8,003,715

Low Temperature

Diameter	Operating Pressure (PSI)									
	2	4	6	8	10	12	14	16	18	20
24" and 28"	455,282	621,824	763,548	884,911	990,006	1,082,569	1,165,971	1,243,226	1,316,983	1,389,534

Gauge Pressure (PSI) Reading to Maintain Temp (Approximate)

Diameter	Static Pressure	Heat Rise (F)						
		60	80	100	120	140	160	180
5 HP - 24"	1"	1	3	4	6	7	9	12
	2"	1	2	3	5	6	8	10
	3"	Low Temp	1	2	3	4	5	7
	4"	Low Temp	Low Temp	1	2	2	3	4
7 HP - 24"	1"	2	3	5	6	8	11	13
	2"	1	2	4	5	7	9	11
	3"	Low Temp	2	3	4	5	7	8
	4"	Low Temp	Low Temp	1	2	3	4	5
10 HP - 24"	1"	2	3	5	7	10	12	16
	2"	1	3	4	6	8	10	12
	3"	Low Temp	2	3	4	6	7	9
	4"	Low Temp	Low Temp	2	2	3	4	5
15 HP - 28"	1"	2	3	5	7	9	12	16
	2"	2	3	4	6	8	10	13
	3"	1	2	3	5	6	8	10
	4"	Low Temp	2	3	4	5	6	8
	5"	Low Temp	Low Temp	2	2	3	4	5

BTUs for Gauge Pressure (PSI) Reading Natural Gas Models (Approximate)

High Temperature

Diameter	Operating Pressure (PSI)									
	1	2	3	4	5	6	7	8	9	10
18"	659,337	831,044	989,238	1,135,039	1,269,526	1,393,734	1,508,661	1,615,262	1,714,449	1,807,097
24"	912,577	1,150,234	1,369,188	1,570,989	1,757,129	1,929,044	2,088,112	2,235,656	2,372,940	2,501,172
28"	1,314,110	1,656,337	1,971,631	2,262,224	2,530,266	2,777,823	3,006,882	3,219,345	3,417,034	3,601,688

Low Temperature

Diameter	Operating Pressure (PSI)									
	1	2	3	4	5	6	7	8	9	10
18"	184,797	232,922	277,261	318,125	355,819	390,631	422,843	452,720	480,520	506,487
24" and 28"	82,132	103,521	123,227	141,389	158,142	173,614	187,930	201,209	213,565	225,105

Gauge Pressure (PSI) Reading to Maintain Temp (Approximate)

Diameter	Static Pressure	Heat Rise (F)						
		60	80	100	120	140	160	180
3 HP - 18"	1"	Low Temp	Low Temp	2	2	3	4	5
	2"	Low Temp	Low Temp	Low Temp	1	2	3	3
5 HP - 24"	1"	1	2	3	5	6	8	10
	2"	Low Temp	2	3	4	5	6	8
	3"	Low Temp	Low Temp	2	3	3	4	5
7 HP - 24"	1"	1	2	4	5	7	8	10
	2"	1	2	3	4	6	7	9
	3"	Low Temp	1	2	3	4	5	7
	4"	Low Temp	Low Temp	1	2	2	3	4
10 HP - 24"	1"	1	3	4	6	8	10	10
	2"	1	2	3	5	6	8	10
	3"	Low Temp	2	3	4	5	6	7
	4"	Low Temp	Low Temp	1	2	3	3	4
15 HP - 28"	1"	1	3	4	6	8	10	10
	2"	1	2	3	5	6	8	10
	3"	1	2	3	4	5	7	8
	4"	Low Temp	1	2	3	4	5	6
	5"	Low Temp	Low Temp	1	2	2	3	4

5. Service

Seasonal Inspection and Service

All heaters are constructed of durable weather-resistant materials, so a minimum amount of service should be required. Before the unit is started for the first time each season there are a few items that need to be checked out. All damaged parts should be repaired or replaced.

1. Disconnect and lock out power to fan/heater. Open control box lid and inspect all components for moisture, vibration or rodent damage. Inspect and tighten all loose terminal connections. Replace any damaged wiring.
2. Remove burner orifice tube and inspect for dirt or foreign material. Clean out if necessary.
3. Inspect holes in burner ring for possible corrosion or plugging with dirt or rust. Clean if necessary.
4. Be sure primary air inlet screen is intact and clean for proper burn.
5. Check perforated ring on natural gas models to be sure it is clean and no holes are plugged.
6. Inspect flame probe and ignitor and adjust or replace if necessary.



Always disconnect and lock out power before working on or around heater.

Internal (Seat) Leakage Testing for Safety Shut Off Valves

NOTE: These instructions were adapted from ASCO valve installation and maintenance instructions and are used with permission. Please refer to the specific installation and maintenance instructions for your specific ASCO valve model for additional details.

1. Shut off both the upstream and downstream manual shut off valves. The downstream manual shut off valve should remain closed during the entire test procedure.
2. Operate the safety shut off valve(s) through five (5) cycles. Listen carefully for the solenoid coil to click indicating proper operation.
3. Open the upstream manual shut off valve. Program the control system to energize and maintain the valve in the open (energized) position. Check all valve and piping connections for external leaks with a rich soap and water solution.
4. Shut off the upstream manual shut off valve and de-energize the safety shut off valve (A). Remove the plug from the leak test tap (B) or downstream pressure tap (F) in the valve body. Connect leak test equipment with the test petcock (G) in the closed position. (See Figure 5A.)

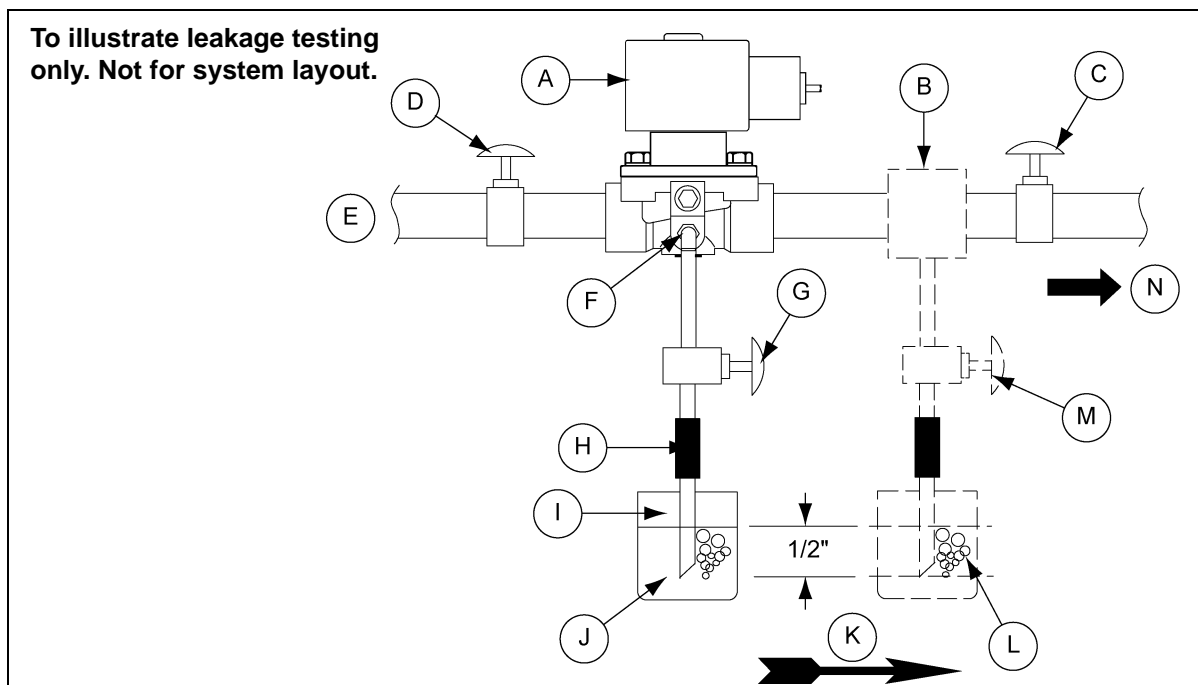

Figure 5A Testing for Internal Seat Leakage

Ref #	Description
A	Safety Shut Off Valve
B	Leak Test Tap
C	Downstream Manual Gas Cock
D	Upstream Manual Gas Cock
E	Gas Supply
F	Downstream Pressure Tap
G	Test Petcock

Ref #	Description
H	1/4" Flex Tubing
I	1/4" Aluminum or Copper Pilot Tubing
J	45° Cut
K	Flow
L	Glass Jar Filled with Water
M	External Leak Text Tap Option
N	To Burner

Internal (Seat) Leakage Testing for Safety Shut Off Valves (Continued)



Some gas will be released to the atmosphere when the pipe plug is removed.

5. Open the upstream manual shut off valve. Program the control system to energize the valve to the full open position, then immediately de-energize it to seat the valve operationally.
6. Immerse the 1/4" leak test tubing vertically into a jar of water to a depth of about 1/2". Slowly open the test petcock (G). Bubbles may appear in the water as the pressure equalizes.
7. After the rate of bubbles coming through the water stabilizes, count the number of bubbles appearing in a 10 seconds period. The allowable leakage in 10 seconds for an orifice diameter of 1" (25.4 mm) or less is six (6) bubbles (3 cc/min). If leakage exceeds this rate, please replace valve.

NOTE: *The leakage rate above recognizes that some wear and contamination from use can result in a slight amount of leakage. The allowable leakage rate is well within the leakage limits as recognized by applicable approval agencies.*

8. Close the upstream manual shut off valve and the test petcock (G). Then remove the test equipment. Apply a small amount of Loctite Corporation's PST Pipe Sealant 567 (or equivalent) to the pipe plug threads. Re-install the pipe plug and tighten securely.



Some gas will be released to the atmosphere when the test equipment is removed.

9. Turn ON the gas supply (E) at the upstream manual shut off valve and energize the safety shut off valve.
10. Open the upstream manual shut off valve. Program the control system to energize and maintain the valve in the open (energized) position. Check the 1/8" NPT pipe plug connection for external leaks with a rich soap and water solution.
11. De-energize the valve. Open the downstream manual gas shut off valve.
12. Restore the system to normal operation.

6. Troubleshooting - Heater

Trouble	Probable Cause	Check-out Procedure
Burner will not fire. No gas pressure on gauge. No ignition spark.	1. Heater not wired.	1. Visually check fan control box to see if wires are connected.
	2. Fan not running.	2. Fan contactor must be energized for heater to run.
	3. Blown fuse.	3. Visually check fuse.
	4. Bad ON/OFF switch.	4. Check ON/OFF switch contact block for proper installation and continuity. Check for power on terminals 1 and 8.
	5. Housing high-limit switch.	5. Reset switch. Check for power on terminals 1 and 8.
	6. Thermostat open.	6. Plenum temperature above set point temperature or open circuit.
	7. Flame probe open.	7. Remove wires from flame probe and check with ohm meter. Probe should be closed when cold.
Burner will not fire. No gas pressure on gauge. Constant ignition spark.	1. Gas supply.	1. Make sure all valves are open to heater and gas tank is not empty.
Burner will not fire. Gas pressure on gauge. No ignition spark.	1. Loose wire.	1. Check for power on terminals 4 and 7. Look for loose wires or incorrect wiring.
	2. Ignitor/spark plug.	2. Turn gas OFF to heater. Check gap on ignitor. Check porcelain for any sign of cracks. Remove plug wire from spark plug/ignitor. Carefully holding wire by insulation. Try to get an arc between end of wire and heater housing (or other wire using two (2) pole transformer).
	3. Ignition transformer/wire.	3. Turn gas OFF to heater. If no spark present after checking ignitor, remove wire from ignition transformer. Check for spark at ignition transformer with an insulated screwdriver. Spark should jump a minimum 1/4" gap. Replace transformer if no spark is established, replace the ignition wires.
Burner will not fire or fires for 30 second and locks out. Gas pressure on gauge. Spark is ON.	1. Plugged orifice.	1. Check for gas at burner. If no gas, remove pipe train and check orifice and burner ring for blockage.
	2. Flame probe.	2. Check to be sure flame probe is in good condition and is located in flame. Flame probe contacts should open when probe gets hot.
	3. Incorrect supply voltage.	3. Voltage to heater must be 110V AC.
	4. Regulator set too low.	4. See that flame burns continuous and is not intermittent. On ring burners be sure flame burns completely around ring.
	5. Moisture in fuel.	5. Have tank and lines checked by a qualified gas service man.

7. Wiring Diagrams

CSA (LP, High-Low) Heater Wiring Diagram

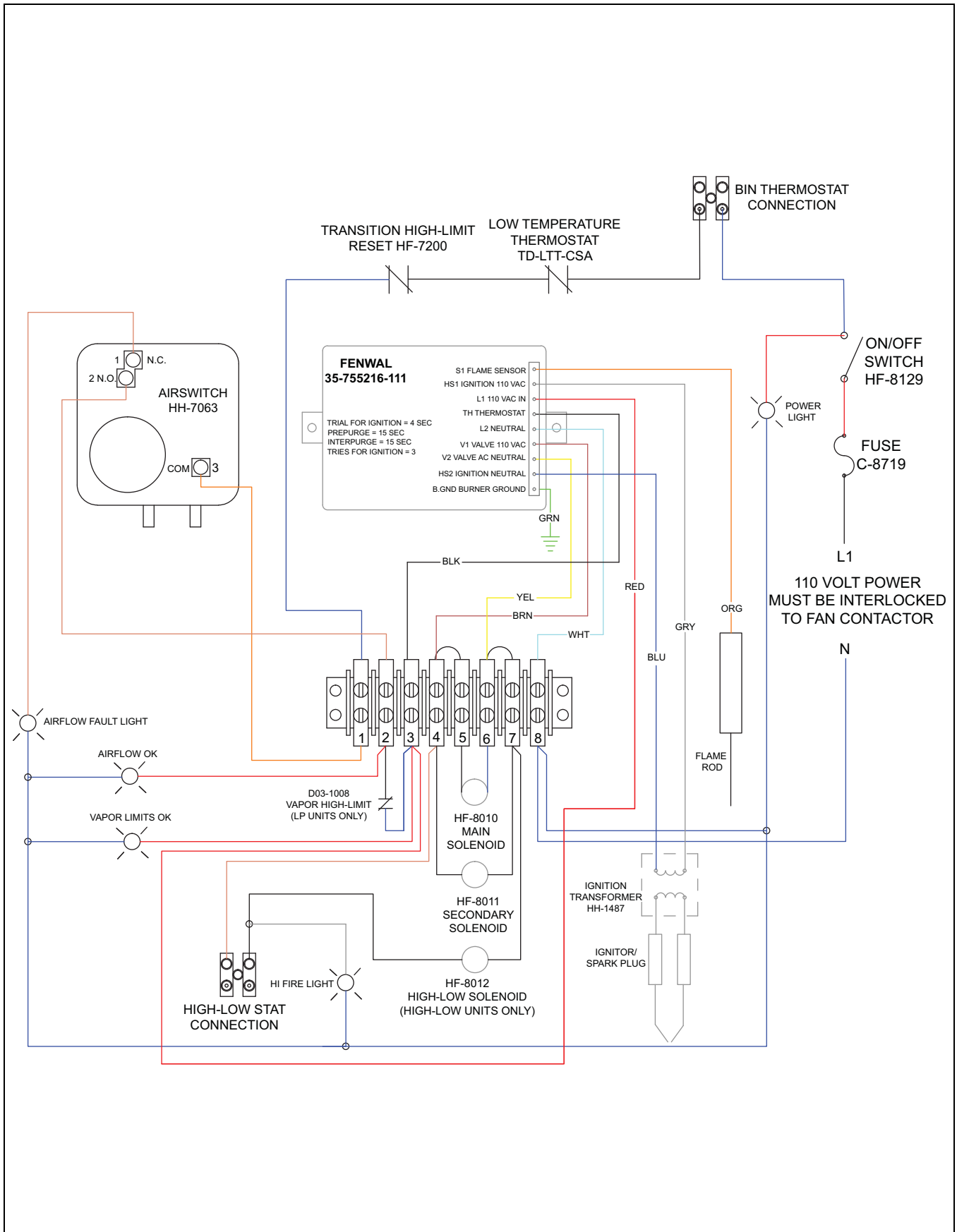

Ladder Logic Control for LP, High-Low CSA Heater

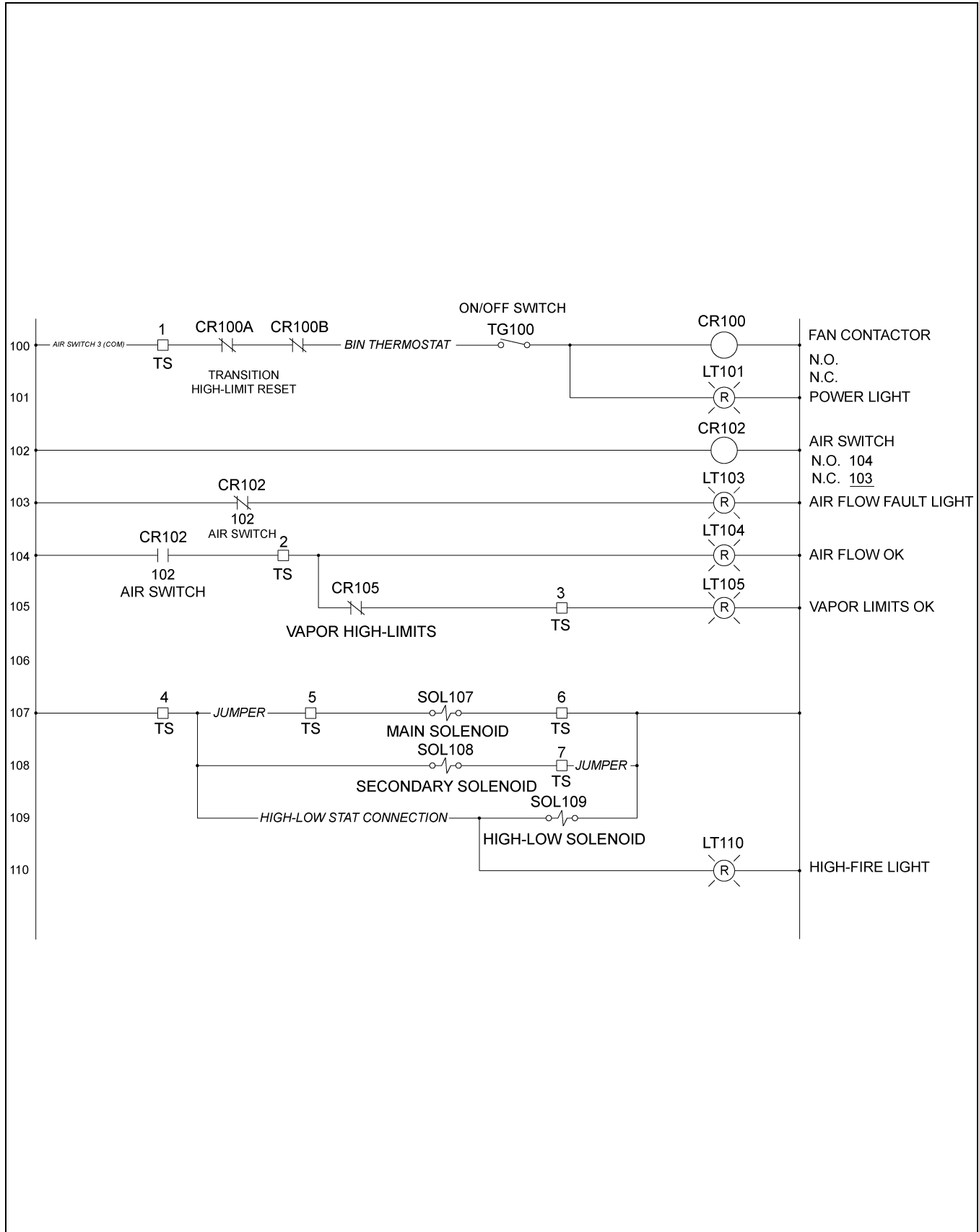

7. Wiring Diagrams

CSA (LP, Non-High-Low) Heater Wiring Diagram

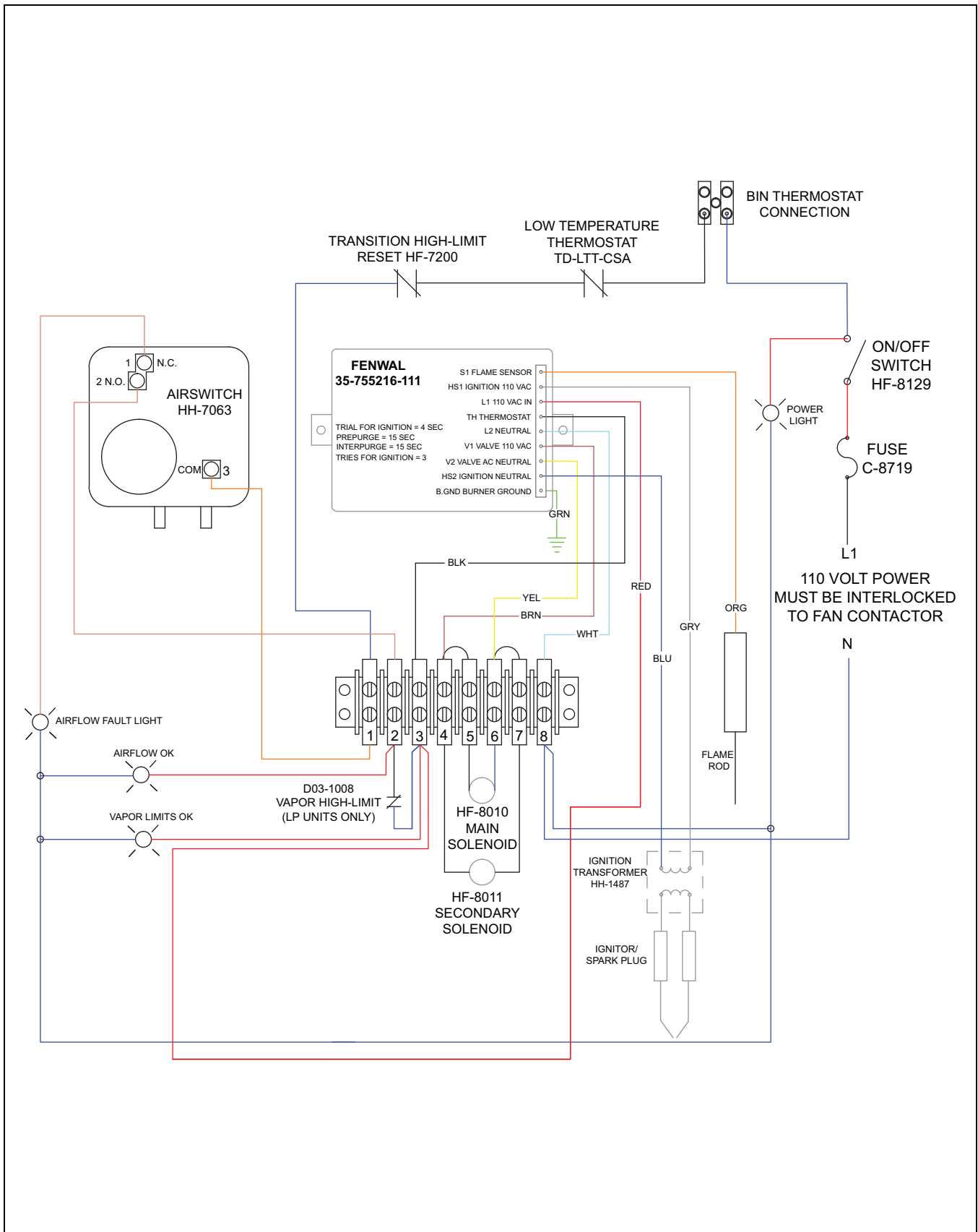

Ladder Logic Control for LP, Non-High-Low CSA Heater

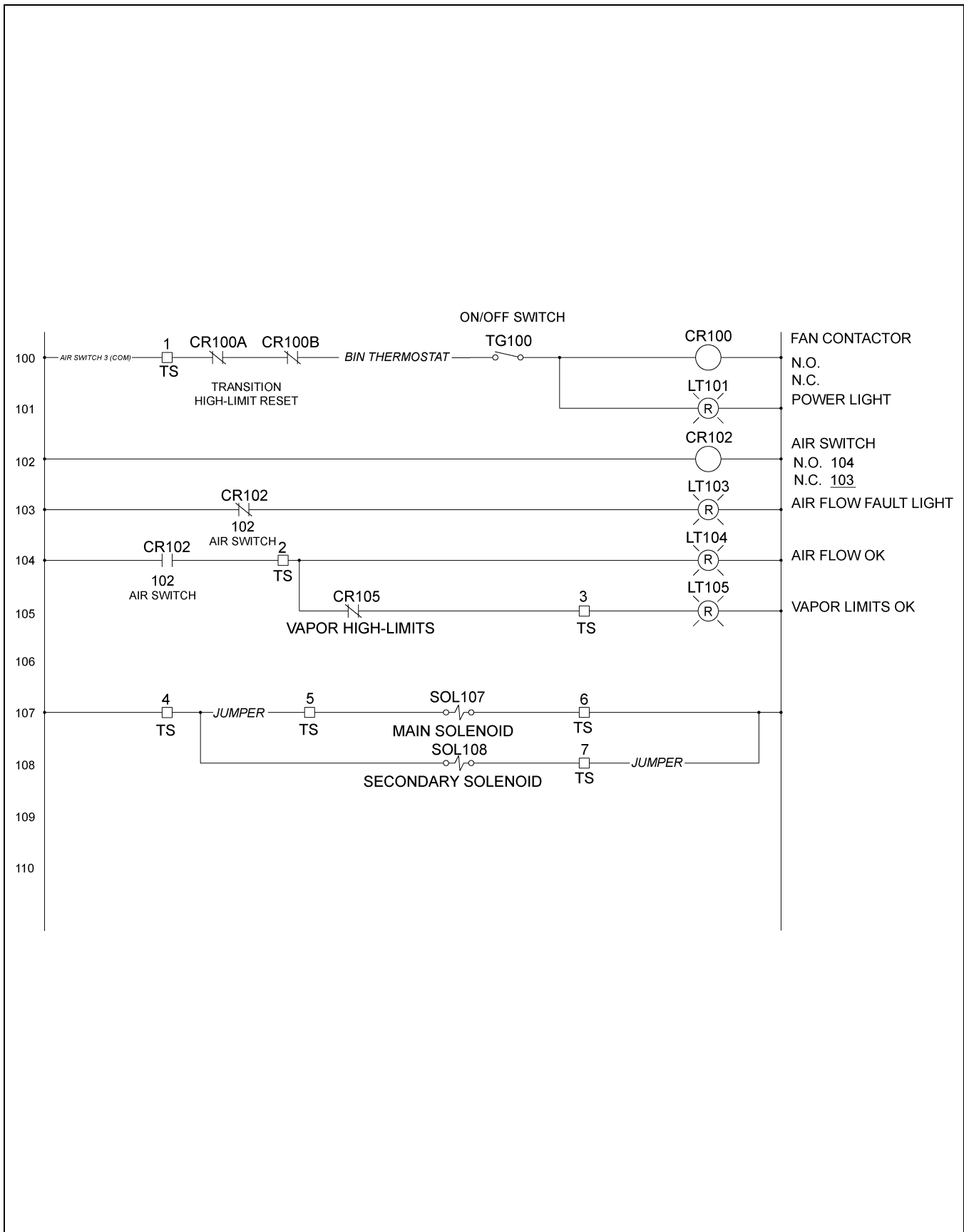

7. Wiring Diagrams

CSA (NG, High-Low) Heater Wiring Diagram

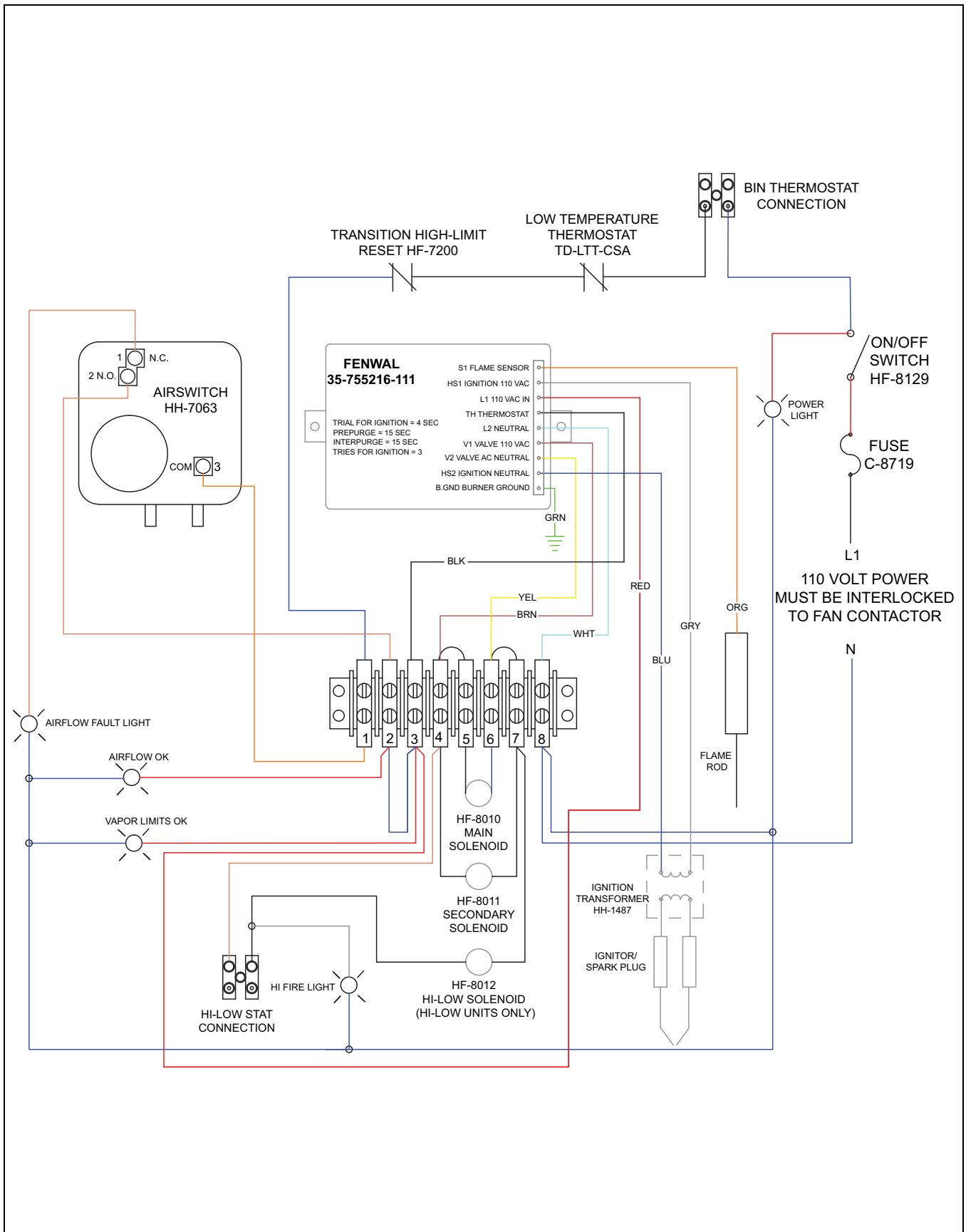

Ladder Logic Control for NG, High-Low CSA Heater

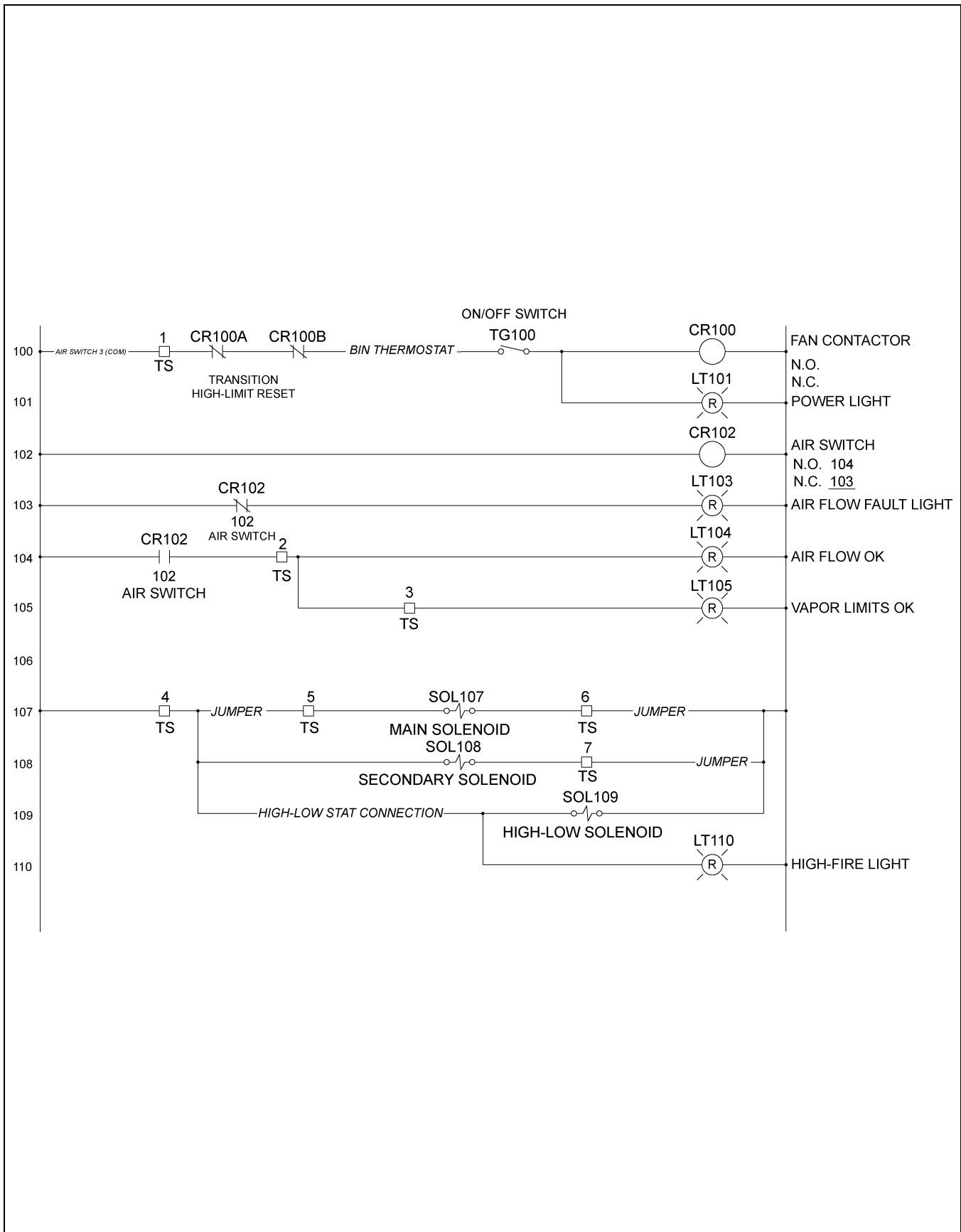

7. Wiring Diagrams

CSA (NG, Non-High-Low) Heater Wiring Diagram

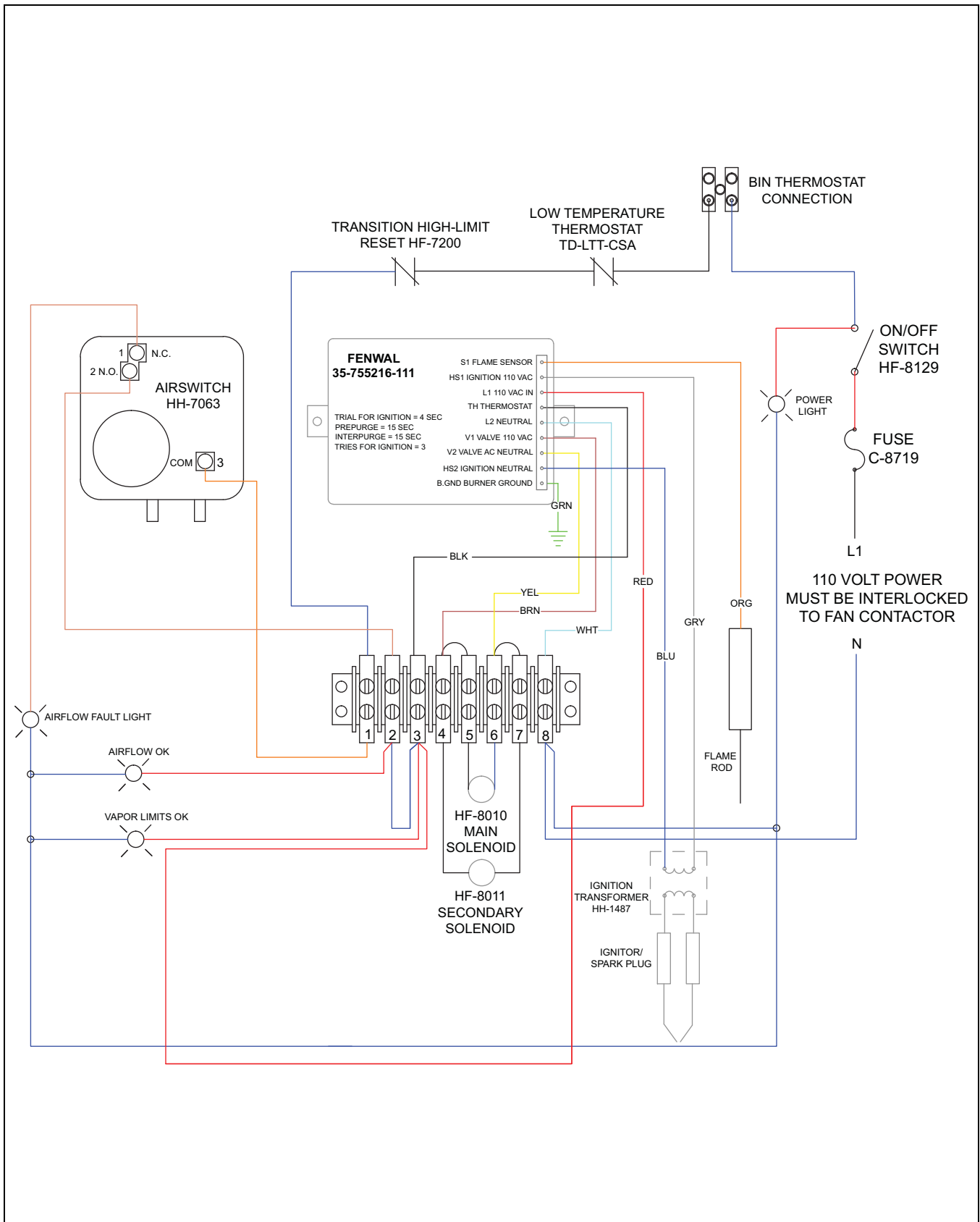

Ladder Logic Control for NG, Non-High-Low CSA Heater

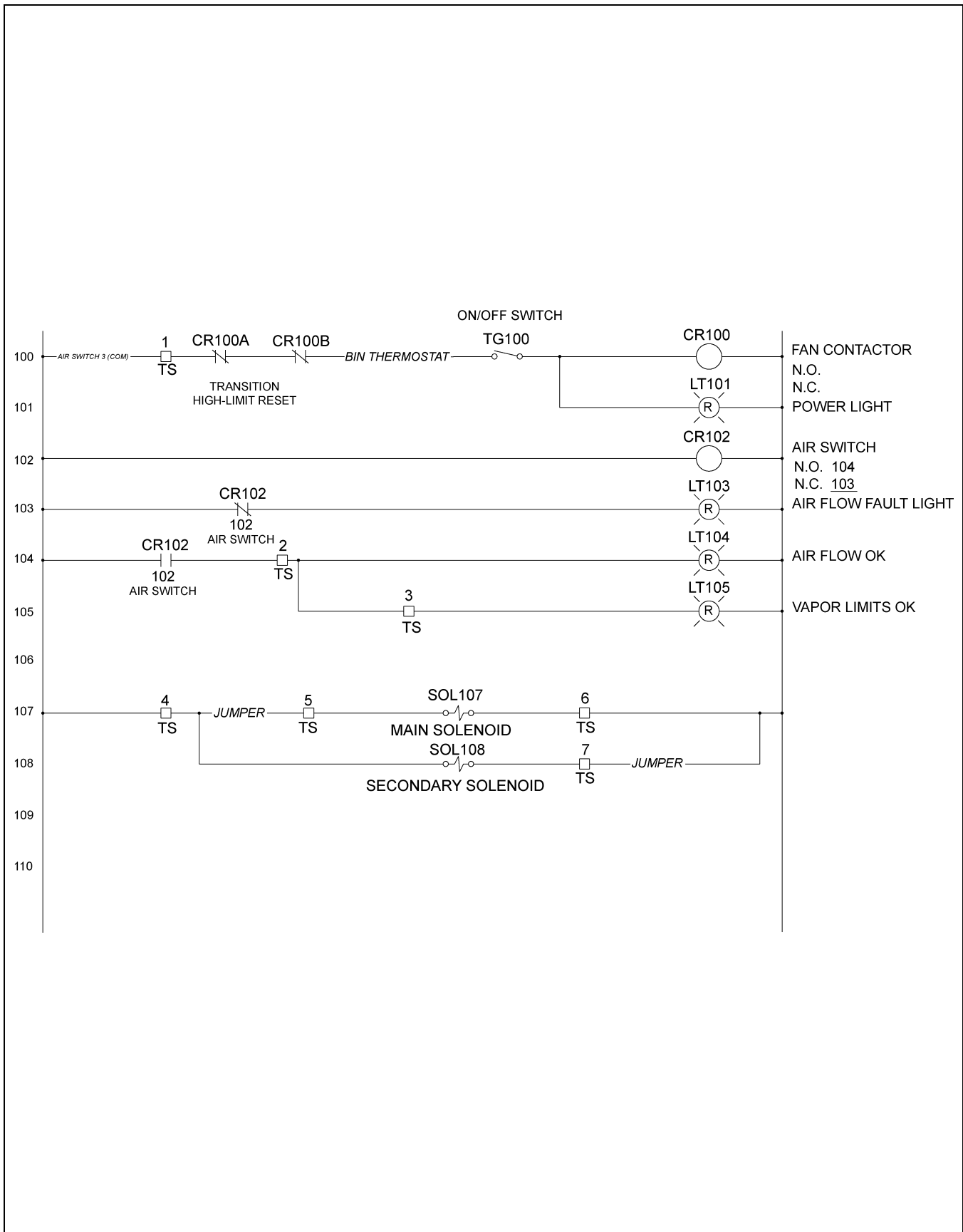

CSA Heater Operation Flow Chart

Heater Global State High/Low-Fire

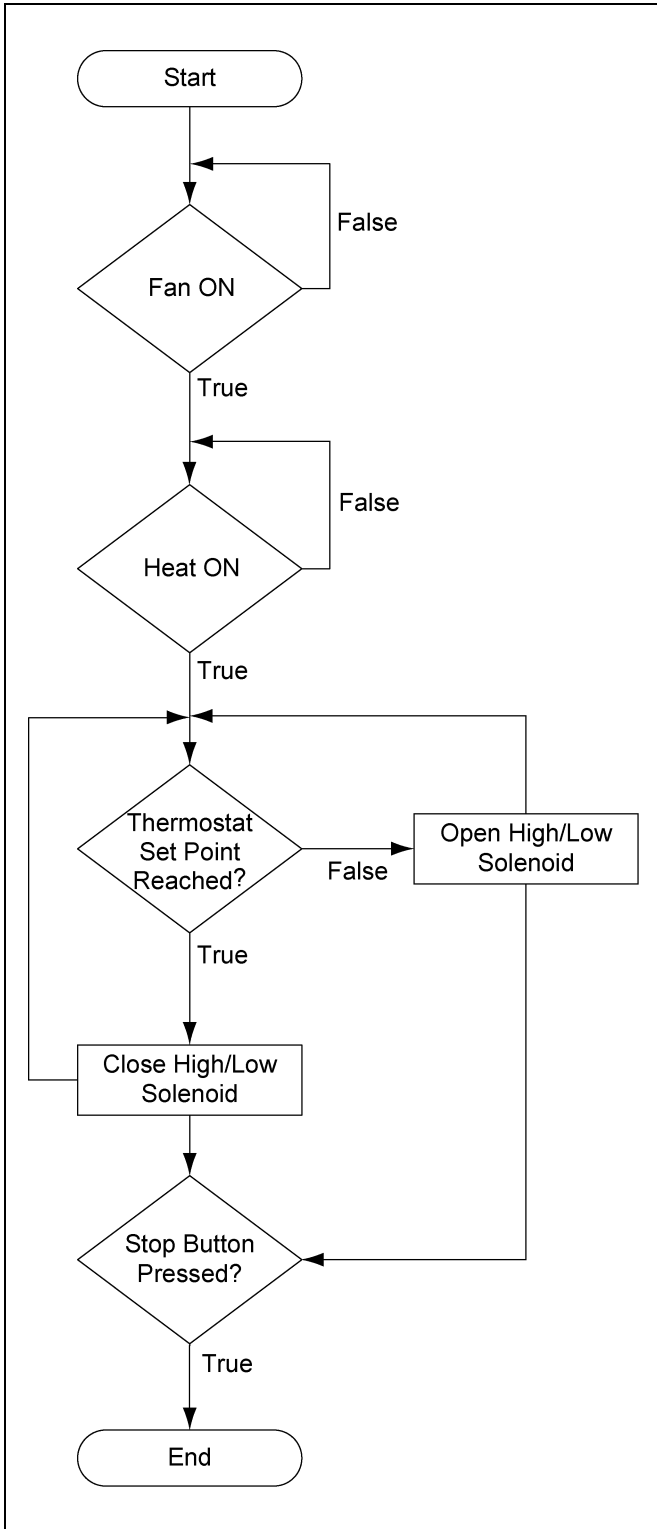

Heater Global State ON/OFF

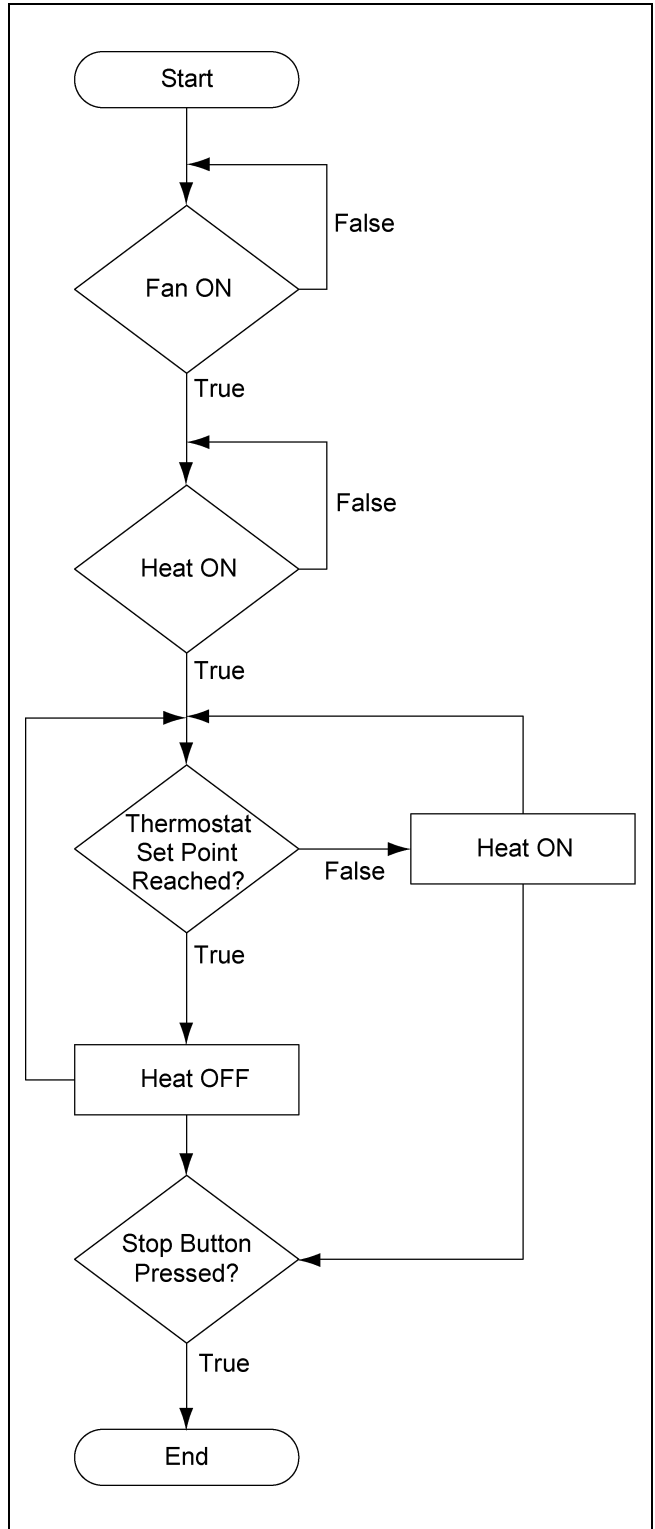

1. **CSA VA Heater Control Box Sub-Assembly (HF-8453)** - *(See Pages 42-43.)*
2. **18", 24" and 28" Gas Heater Parts** - *(See Pages 44-45.)*
3. **CSA 18" Vane Axial Propane Pipe Train Sub-Assembly (HF-8216)** - *(See Page 46.)*
4. **CSA Vane Axial Propane Pipe Train Cycling (HF-8378)** - *(See Page 47.)*
5. **CSA Vane Axial Propane High-Low Pipe Train (HF-8379)** - *(See Page 48.)*
6. **CSA 24" Propane Vapor Pipe Train Sub-Assembly (HF-8217)** - *(See Page 49.)*
7. **CSA 28" Vane Axial LP Pipe Train Sub-Assembly (HF-8201)** - *(See Page 50.)*
8. **CSA 24" Propane Vapor LP High-Low Pipe Train Sub-Assembly (HF-8218)** - *(See Page 51.)*
9. **CSA 28" Propane Vapor LP High-Low Pipe Train Sub-Assembly (HF-8220)** - *(See Page 52.)*
10. **CSA Vapor/NG High-Low Pipe Train Assembly (HF-8381)** - *(See Page 53.)*
11. **CSA Vapor/NG Pipe Train Cycling (HF-8380)** - *(See Page 54.)*
12. **CSA LP Supply Pipe Train Sub-Assembly (HF-8203)** - *(See Page 55.)*

CSA VA Heater Control Box Sub-Assembly (HF-8453)

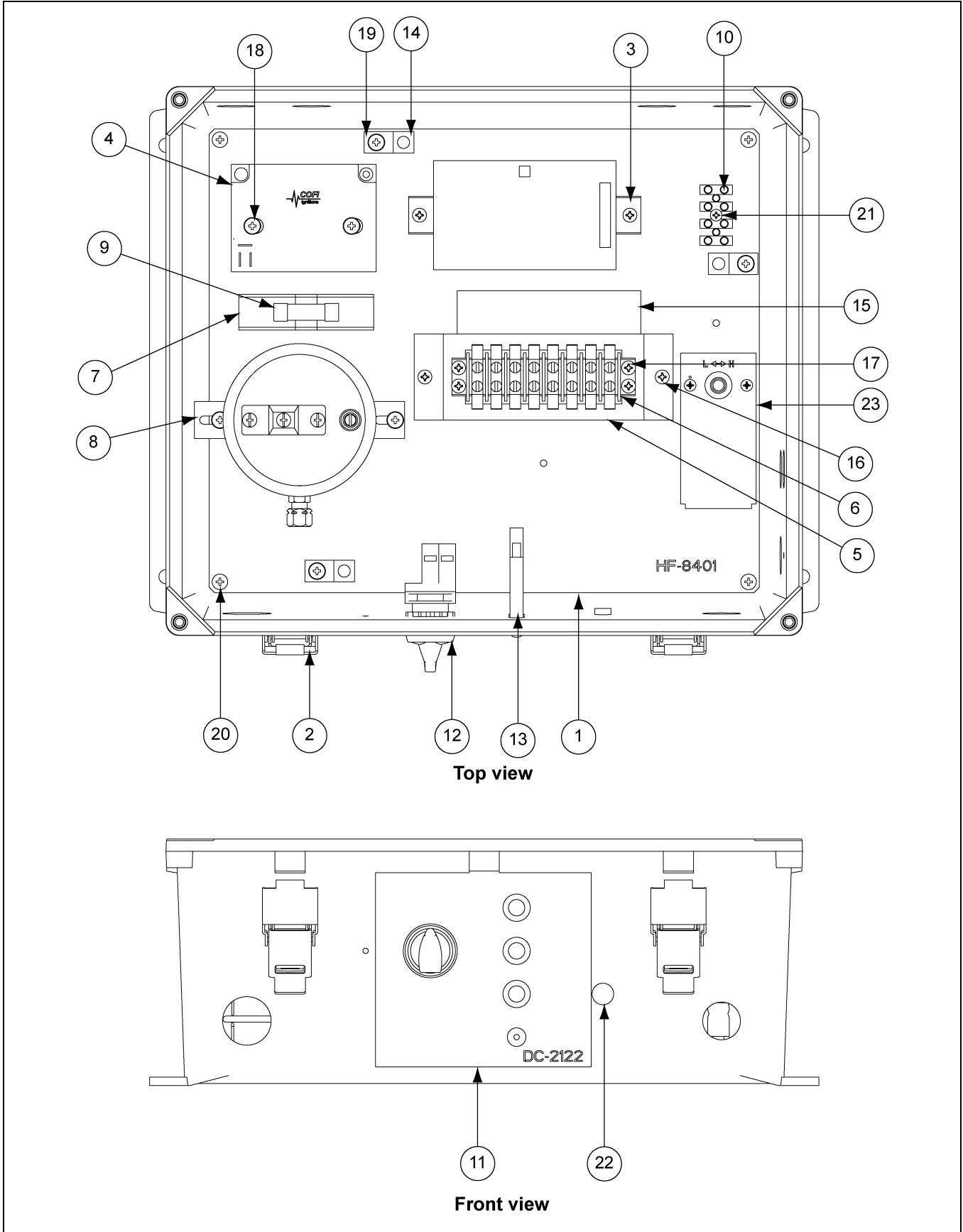

CSA VA Heater Control Box Sub-Assembly (HF-8453) Parts List

Ref #	Part #	Description	Qty
1	HF-8401	Backing Plate, Heater Cont C-8838	1
2	C-8838	Enclosure, Heater Non-Metalic 14" x 12" x 7" Nema 4 x VYNC RVJ	1
3	HF-4624-DWH	Fenwal, Flame CSA 15 Sec Purge, 3 Retries	1
4	GT3-1457	Single Pole Cofi Ignition Transformer CE Rated	1
5	HF-7697	Term Strip Bracket	1
6	TFH-2013	Terminal, Block 8 Pole	1
7	C-8718	Single Pole Midget Fuse Block	1
8	HH-7063	Switch, Air (Antunes)	1
9	C-8719	Slow Blow 3A Midget Fuse 500 VAC, 10KA I.R.	1
10	E240-1107	Terminal Strip 12 Position 10A 12 Gauge	1
11	DC-2122	Decal, CSA Heater Control	1
12	DSA-VIS-POWR	Dryer Switch Assembly Vis Power ON/OFF	1
13	90-0009	Lamp, 120V Amber	3
14	E160-1137	Lug Ground, #TA-2 (CSA)	3
15	DC-2106	Decal, Standard Heater Terminal Strip	1
16	S-2786	Screw, TCSF #8-32 x 3/8" PHP ZN	5
17	S-7192	Screw, TCSF #8-32 x 5/8" PHP ZN	6
18	S-10176	Screw, TCSF #10-32 x 1-3/4" PHP ZN	2
19	090-1701-3	Screw, MS #10-24 x 1/2" PHS ZN	5
20	S-8976	Screw, MS #10-32 x 3/8" PHP ZN Grade 2	4
21	S-9111	Screw, TCSF #6-32 x 3/4" PHP ZN	1
22	048-1042-0	Hole Plug 3/8"	1
23	VIS-LTT-CSA	Low Temp Thermostat with Cover, Vision CSA	1
N/S	DC-2419	Decal, Tag, Attention, CE, CSA Harmonized	1
N/S	C-8719	Slow Blow 3A Midget Fuse 500 VAC, 10KA I.R.	1
N/S	D03-0099	Adapter, Tab 3/16" x 3/16"	3
N/S	D03-0562	Cover, Fuse Block Bussman Sami - 7N	1
N/S	D03-0649	Elbow, 1/4" CMP x 1/8" NPT Brass	4
N/S	D03-1140	Connector, Ignition Wires Cofi #112010	1
N/S	HF-7463	Tube, 1/4" O.D. 3/16" I.D. UV Resist	6
N/S	HF-8008	Wire, Spark Plug Suppression	5
N/S	HF-8422	Wiring Harness for HF-4624-DWH Made in House	1
N/S	HH-7046	Crimp, Disconnect 3/16" Female	6
N/S	HH-7203	Plug, Hole 7/8" D 1/16" - 1/4" T C2070	2
N/S	S-4764	Terminal, Fork Part Insulated x 2 Wire Blue	6
N/S	TFC-0048	Disconnect, 1/4" Insul Fem CSA Panduit #DVI4-250B-M	4

8. Parts List

18", 24" and 28" Gas Heater Parts

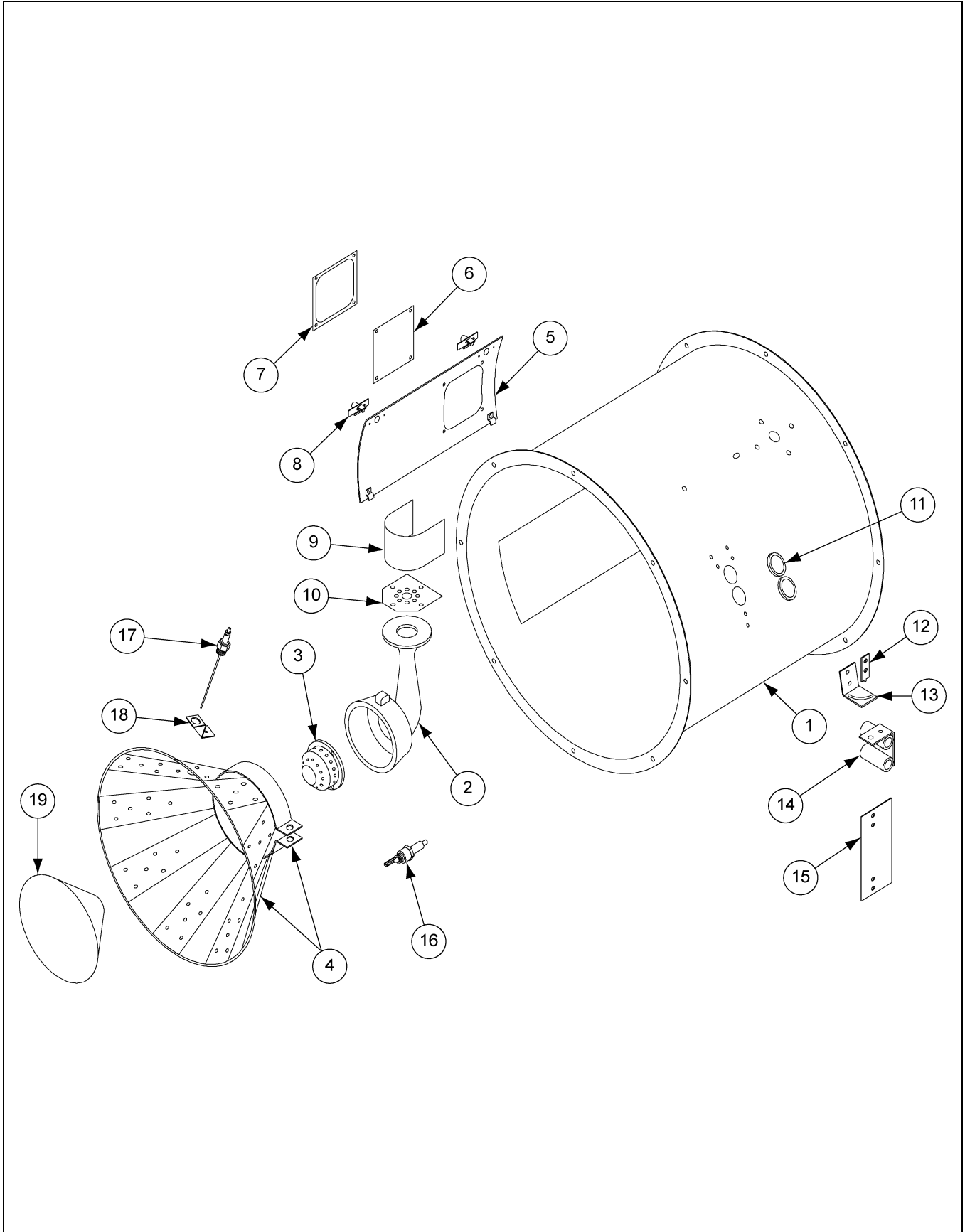

18", 24" and 28" Gas Heater Parts List

Ref #	Part #			Description
	18"	24"	28"	
1	HF-8211	HF-8212	HF-8213	Heater Housing
2	HH-3934	HH-3934	HH-3934	Burner Casting
3	HF-6757	HF-6757	HF-6757	Flame Spreader (Low Temperature)
4	HF-992	HF-992	HF-992	Flame Diverter Weldment
5	HF-6062-18	HF-6065-24	HF-6065-28	Access Panel
6	HF-7380	HF-7380	HF-7380	Plastic View Window
7	HF-7379	HF-7379	HF-7379	Access Panel Cover Plate
8	TFH-2046	TFH-2046	TFH-2046	Access Panel Latch
9	HF-986	HF-983	HF-7517	Burner Collector
10	HF-978	HF-978	HF-978	Burner Collector Plate
11	N/A	HH-7016	HH-7016	Rubber Grommet - LP Model Only
12	N/A	HF-7056	HF-7056	Pivot Bracket - LP Model Only
13	N/A	HF-7057	HF-7057	Adjustment Bracket - LP Model Only
14	N/A	HF-7060	HF-7060	Vaporizer Support Weldment - LP Model Only
15	N/A	THF-3237	THF-3237	Vaporizer Cover - Vapor/NG Only
16	HH-1650	HH-1650	HH-1650	Spark Plug
17	THH-4179	THH-4179	THH-4179	Flame Sensor
18	CD-0187	CD-0187	CD-0187	Flame Sensor Bracket
19	N/A	HH-7054	HH-7054	Burner Cone
N/S	053-1004-0	053-1004-0	053-1004-0	Spark Plug Nut
N/S	HF-7262	HF-7262	HF-7262	Flame Sensor Wire Assembly
N/S	HH-5430	HH-5430	HH-5430	Flame Probe Wire Assembly
N/S	HF-7260	HF-7260	HF-7260	Spark Plug Wire Assembly
N/S	7098556	7098556	7098556	Shroud, for 16" Motor Cord

8. Parts List

CSA 18" Vane Axial Propane Pipe Train Sub-Assembly (HF-8216)

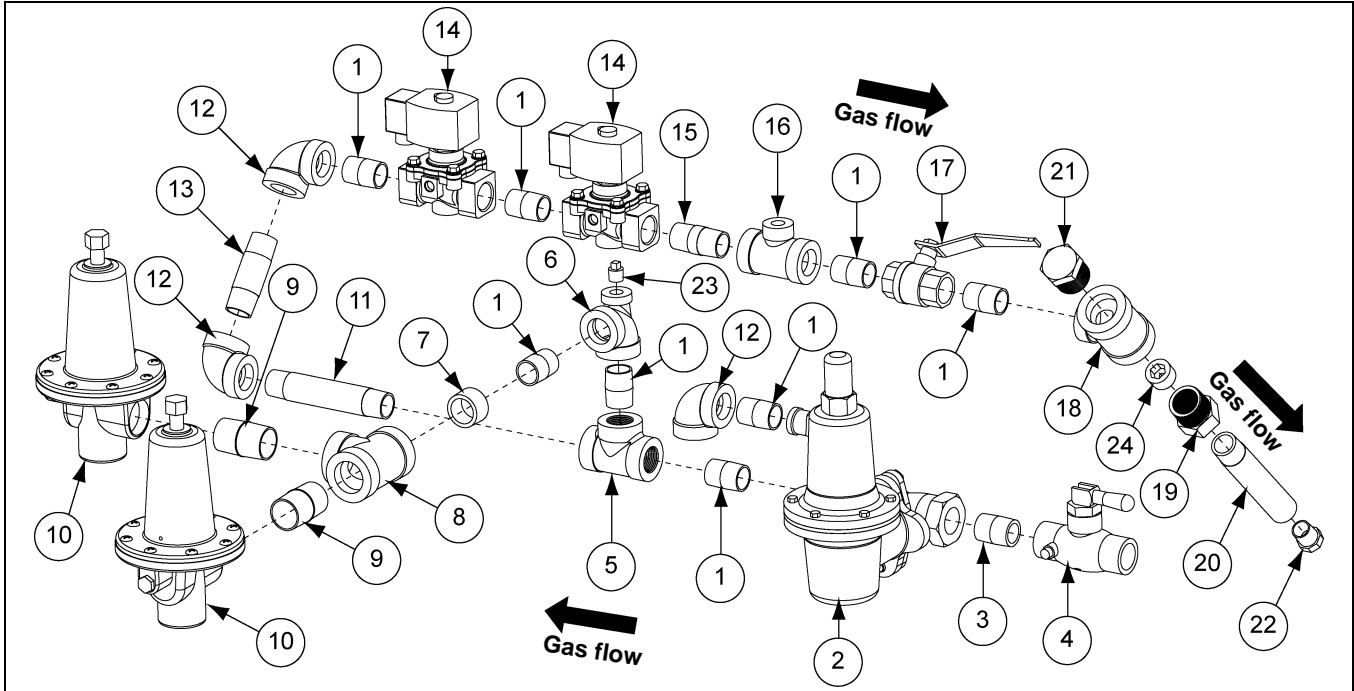

CSA 18" Vane Axial Propane Pipe Train Sub-Assembly (HF-8216) Parts List

Ref #	Part #	Description	Qty
1	THH-4121	Nipple, 3/4" Close SCH 40 Black	8
2	D03-0880	Regulator, LP 5-20 PSI Spring, 0.5 Orifice, 3/4" NPT	1
3	D67-0021	Nipple, 3/4" Close SCH 80 Black	1
4	D03-0841	Valve, 3/4" NPT LP Quick Shut Off CSA	1
5	THH-4124	Tee, 3/4" x 3/4" x 3/4" SCH 40 Black	1
6	THH-4158	Tee, 3/4" x 1/4" x 3/4" SCH 40 Black	1
7	007-1338-8	Bushing, Flush 1" to 3/4"	1
8	THH-4137	Tee, 1" x 1" x 1" SCH 40 Black	1
9	007-1242-2	Nipple, 1" x 2" SCH 40 Black	2
10	D03-0881	Valve, Relief - 15-50 PSI Spring LP, 1" NPT, 300F Rating, Preset	2
11	007-1264-6	Nipple, 3/4" x 5" SCH 40 Black	1
12	THH-4120	Elbow, 3/4"-90° SCH 40 Black	3
13	THH-4136	Nipple, 3/4" x 3" SCH 40 Black	1
14	056-2223-8	Valve, Solenoid 3/4" NPT 115V Din 50 PSI	2
15	THH-4125	Nipple, 3/4" x 2" SCH 40 Black	1
16	THH-4154	Tee, 3/4" x 3/4" x 1/4" SCH 40 Black	1
17	D03-0837	Valve, 3/4" NPT Full Port, Lever, CSA, Brass or Bronze	1
18	D08-0017	Tee, 1" x 1" x 3/4" SCH 40 Black	1
19	HF-7794	Orifice Holder - Quad Heater - 3/4"	1
20	HH-7026	Orifice Pipe 3/4" x 5-1/2"	1
21	D08-0014	Plug, Hex-Head, Black Steel, 1" NPT	1
22	HF-7126	Orifice (3/4") Drilled 3/8"	1
23	007-1747-0	Plug, 1/4" NPT Square Black	1
24	HF-7931	Orifice Plug (3/4) Drill: 13/64"	1

CSA Vane Axial Propane Pipe Train Cycling (HF-8378)

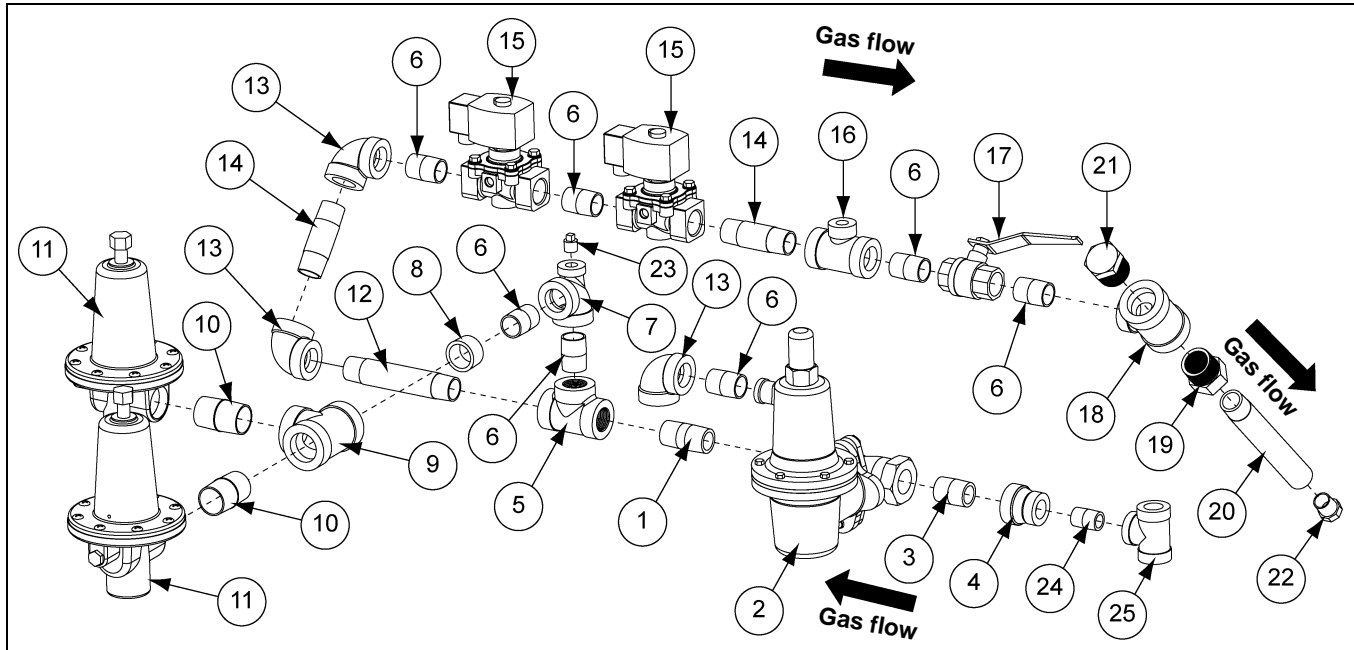

CSA Vane Axial, Propane Pipe Train Cycling (HF-8378) Parts List

Ref #	Part #	Description	Qty
1	GT3-0743	Nipple, 3/4" x 2" SCH 80 Black	1
2	D03-0880	Regulator, LP 5-20 PSI Spring, 0.5 Orifice, 3/4" NPT	1
3	D67-0021	Nipple, 3/4" Close SCH 80 Black	1
4	007-1930-2	Bell, Reducer 3/4" to 1/2" SCH 80	1
5	THH-4124	Tee, 3/4" x 3/4" x 3/4" SCH 40 Black	1
6	THH-4121	Nipple, 3/4" Close SCH 40 Black	7
7	THH-4158	Tee, 3/4" x 1/4" x 3/4" SCH 40 Black	1
8	007-1338-8	Bushing, Flush 1" to 3/4"	1
9	THH-4137	Tee, 1" x 1" x 1" SCH 40 Black	1
10	007-1242-2	Nipple, 1" x 2" SCH 40 Black	2
11	D03-0881	Valve, Relief - 15-50 PSI Spring LP, 1" NPT, 300F Rating, Preset	2
12	007-1264-6	Nipple, 3/4" x 5" SCH 40 Black	1
13	THH-4120	Elbow, 3/4"-90° SCH 40 Black	3
14	THH-4136	Nipple, 3/4" x 3" SCH 40 Black	2
15	056-2223-8	Valve, Solenoid 3/4" NPT 115V Din 50 PSI	2
16	THH-4154	Tee, 3/4" x 3/4" x 1/4" SCH 40 Black	1
17	D03-0837	Valve, 3/4" NPT Full Port, Lever, CSA, Brass or Bronze	1
18	D08-0017	Tee, 1" x 1" x 3/4" SCH 40 Black	1
19	HF-7794	Orifice Holder - Quad Heater - 3/4"	1
20	HF-7539	Orifice Pipe 3/4" x 7" NPT One End	1
21	D08-0014	Plug, Hex-Head, Black Steel, 1" NPT	1
22	HF-7126	Orifice (3/4") Drilled 3/8"	1
23	007-1747-0	Plug, 1/4" NPT Square Black	1
24	THH-4113	Nipple, 1/2" Close SCH 80 Black	1
25	THH-4058	Tee, 1/2" x 1/2" x 1/2" SCH 80 Black	1

8. Parts List

CSA Vane Axial Propane High-Low Pipe Train (HF-8379)

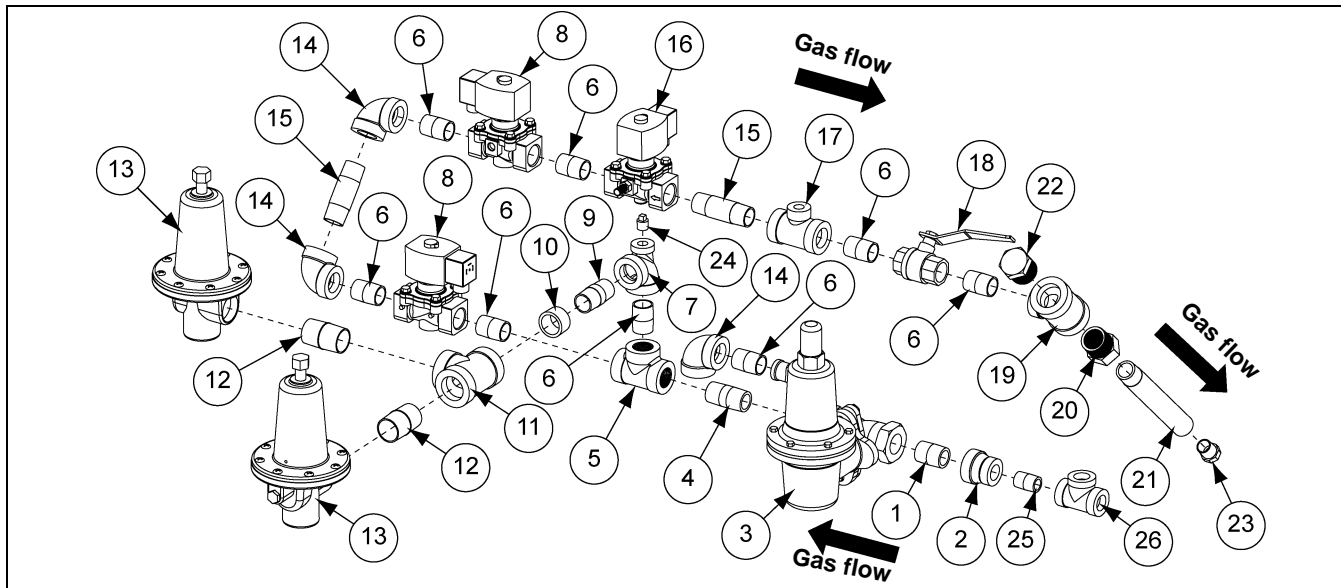

CSA Vane Axial, Propane High-Low Pipe Train (HF-8379) Parts List

Ref #	Part #	Description	Qty
1	D67-0021	Nipple, 3/4" Close SCH 80 Black	1
2	007-1930-2	Reducer, Bell 3/4" x 1/2" SCH 80	1
3	D03-0880	Regulator, LP 5-20 PSI Spring, 0.5 Orifice, 3/4" NPT	1
4	GT3-0743	Nipple, 3/4" x 2" SCH 80 Black	1
5	THH-4124	Tee, 3/4" x 3/4" x 3/4" SCH 40 Black	1
6	THH-4121	Nipple, 3/4" Close SCH 40 Black	8
7	THH-4158	Tee, 3/4" x 1/4" x 3/4" SCH 40 Black	1
8	056-2223-8	Valve, Solenoid 3/4" NPT 115V Din 50 PSI	2
9	THH-4125	Nipple, 3/4" x 2" SCH 40 Black	1
10	007-1338-8	Bushing, Flush 1" to 3/4"	1
11	THH-4137	Tee, 1" x 1" x 1" SCH 40 Black	1
12	007-1242-2	Nipple, 1" x 2" SCH 40 Black	2
13	D03-0881	Valve, Relief - 15-50 PSI Spring LP, 1" NPT, 300F Rating, Preset	2
14	THH-4120	Elbow, 3/4"-90° SCH 40 Black	3
15	THH-4136	Nipple, 3/4" x 3" SCH 40 Black	2
16	056-2228-7	Valve, Solenoid 3/4" NPT 115V Din 50 PSI	1
17	THH-4154	Tee, 3/4" x 3/4" x 1/4" SCH 40 Black	1
18	D03-0837	Valve, 3/4" NPT Full Port, Lever, CSA, Brass or Bronze	1
19	D08-0017	Tee, 1" x 1" x 3/4" SCH 40 Black	1
20	HF-7794	Orifice Holder - Quad Heater - 3/4"	1
21	HF-7539	Orifice Pipe 3/4" x 7" NPT One End	1
22	D08-0014	Plug, Hex-Head, Black Steel, 1" NPT	1
23	HF-7126	Orifice (3/4") Drilled 3/8"	1
24	007-1747-0	Plug, 1/4" NPT Square Black	1
25	THH-4113	Nipple, 1/2" Close SCH 80 Black	1
26	THH-4058	Tee, 1/2" x 1/2" x 1/2" SCH 80 Black	1

CSA 24" Propane Vapor Pipe Train Sub-Assembly (HF-8217)

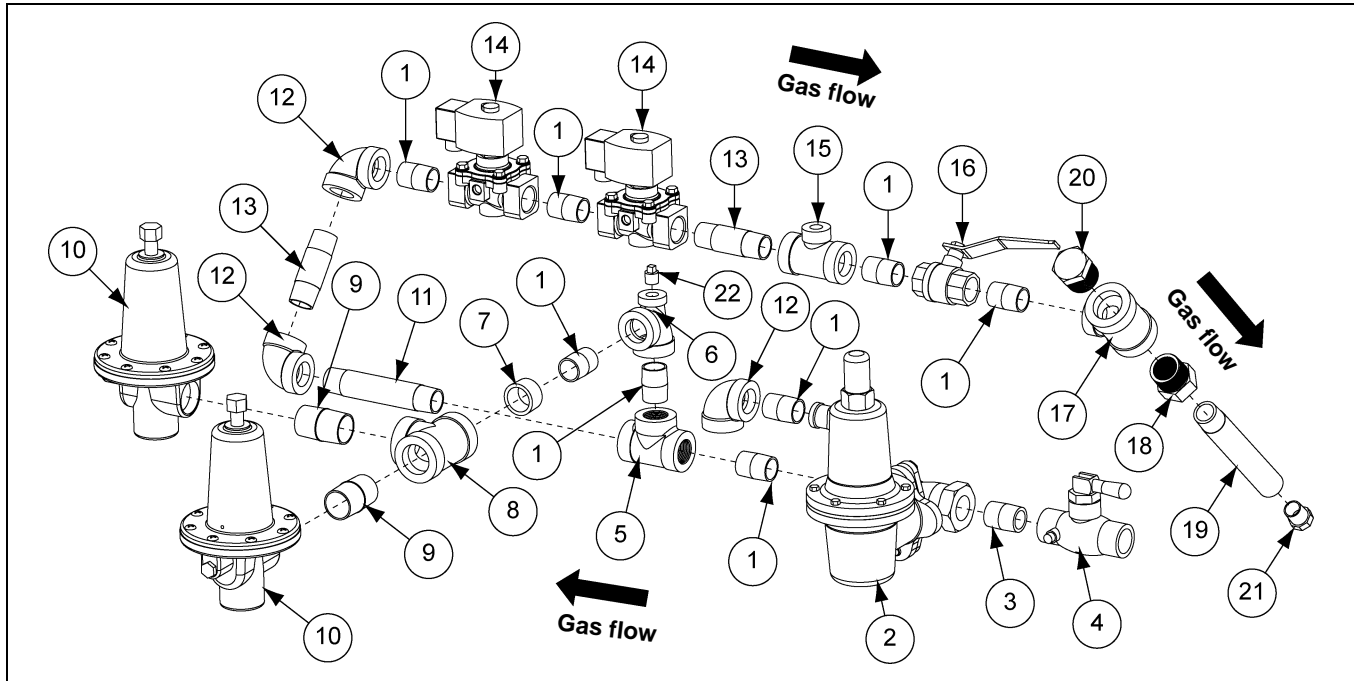

CSA 24" Propane Vapor Pipe Train Sub-Assembly (HF-8217) Parts List

Ref #	Part #	Description	Qty
1	THH-4121	Nipple, 3/4" Close SCH 40 Black	8
2	D03-0880	Regulator, LP 5-20 PSI Spring, 0.5 Orifice, 3/4" NPT	1
3	D67-0021	Nipple, 3/4" Close SCH 80 Black	1
4	D03-0841	Valve, 3/4" NPT LP Quick Shut Off CSA	1
5	THH-4124	Tee, 3/4" x 3/4" x 3/4" SCH 40 Black	1
6	THH-4158	Tee, 3/4" x 1/4" x 3/4" SCH 40 Black	1
7	007-1338-8	Bushing, Flush 1" to 3/4"	1
8	THH-4137	Tee, 1" x 1" x 1" SCH 40 Black	1
9	007-1242-2	Nipple, 1" x 2" SCH 40 Black	2
10	D03-0881	Valve, Relief - 15-50 PSI Spring LP, 1" NPT, 300F Rating, Preset	2
11	007-1264-6	Nipple, 3/4" x 5" SCH 40 Black	1
12	THH-4120	Elbow, 3/4"-90° SCH 40 Black	3
13	THH-4136	Nipple, 3/4" x 3" SCH 40 Black	2
14	056-2223-8	Valve, Solenoid 3/4" NPT 115V Din 50 PSI	2
15	THH-4154	Tee, 3/4" x 3/4" x 1/4" SCH 40 Black	1
16	D03-0837	Valve, 3/4" NPT Full Port, Lever, CSA, Brass or Bronze	1
17	D08-0017	Tee, 1" x 1" x 3/4" SCH 40 Black	1
18	HF-7794	Orifice Holder - Quad Heater - 3/4"	1
19	HH-7027	Orifice Pipe, 3/4" x 6-1/2"	1
20	D08-0014	Plug, Hex-Head, Black Steel, 1" NPT	1
21	HF-7126	Orifice (3/4") Drilled 3/8"	1
22	007-1747-0	Plug, 1/4" NPT Square Black	1

8. Parts List

CSA 28" Vane Axial LP Pipe Train Sub-Assembly (HF-8201)

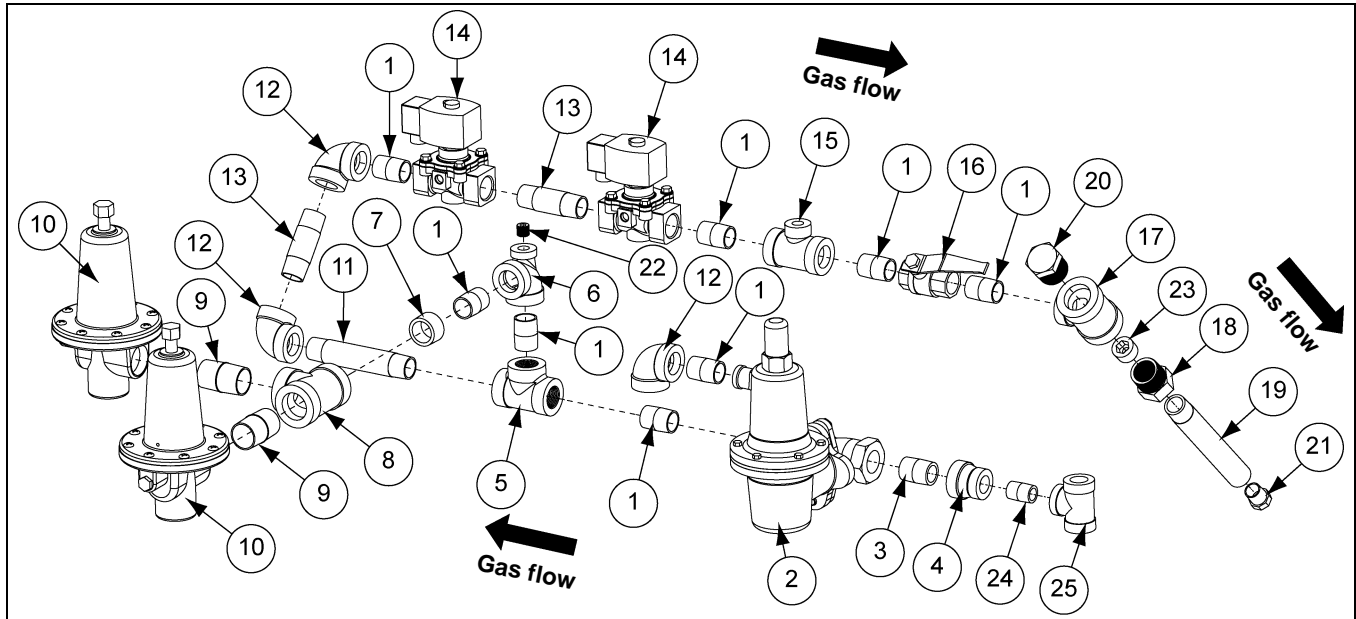

CSA 28" Vane Axial LP Pipe Train Sub-Assembly (HF-8201) Parts List

Ref #	Part #	Description	Qty
1	THH-4121	Nipple, 3/4" Close SCH 40 Black	8
2	D03-0880	Regulator, LP 5-20 PSI Spring, 0.5 Orifice, 3/4" NPT	1
3	D67-0021	Nipple, 3/4" Close SCH 80 Black	1
4	007-1930-2	Bell, Reducer 3/4" to 1/2" SCH 80	1
5	THH-4124	Tee, 3/4" x 3/4" x 3/4" SCH 40 Black	1
6	THH-4158	Tee, 3/4" x 1/4" x 3/4" SCH 40 Black	1
7	007-1338-8	Bushing, Flush 1" to 3/4"	1
8	THH-4137	Tee, 1" x 1" x 1" SCH 40 Black	1
9	007-1242-2	Nipple, 1" x 2" SCH 40 Black	2
10	D03-0881	Valve, Relief - 15-50 PSI Spring LP, 1" NPT, 300F Rating, Preset	2
11	007-1264-6	Nipple, 3/4" x 5" SCH 40 Black	1
12	THH-4120	Elbow, 3/4"-90° SCH 40 Black	3
13	THH-4136	Nipple, 3/4" x 3" SCH 40 Black	2
14	056-2223-8	Valve, Solenoid 3/4" NPT 115V Din 50 PSI	2
15	THH-4154	Tee, 3/4" x 3/4" x 1/4" SCH 40 Black	1
16	D03-0837	Valve, 3/4" NPT Full Port, Lever, CSA, Brass or Bronze	1
17	D08-0017	Tee, 1" x 1" x 3/4" SCH 40 Black	1
18	HF-7794	Orifice Holder - Quad Heater - 3/4"	1
19	HF-7539	Orifice Pipe 3/4" x 7"	1
20	D08-0014	Plug, Hex-Head, Black Steel, 1" NPT	1
21	HF-7126	Orifice (3/4") Drilled 3/8"	1
22	FLX-3788	Plug, 1/4" NPT Recessed Hex Galvanized	1
23	HF-7809	Orifice Plug (3/4") Drilled 5/16"	1
24	THH-4113	Nipple, 1/2" x Close SCH 80 Black	1
25	THH-4058	Tee, 1/2" x 1/2" x 1/2" SCH 80 Black	1

CSA 24" Propane Vapor LP High-Low Pipe Train Sub-Assembly (HF-8218)

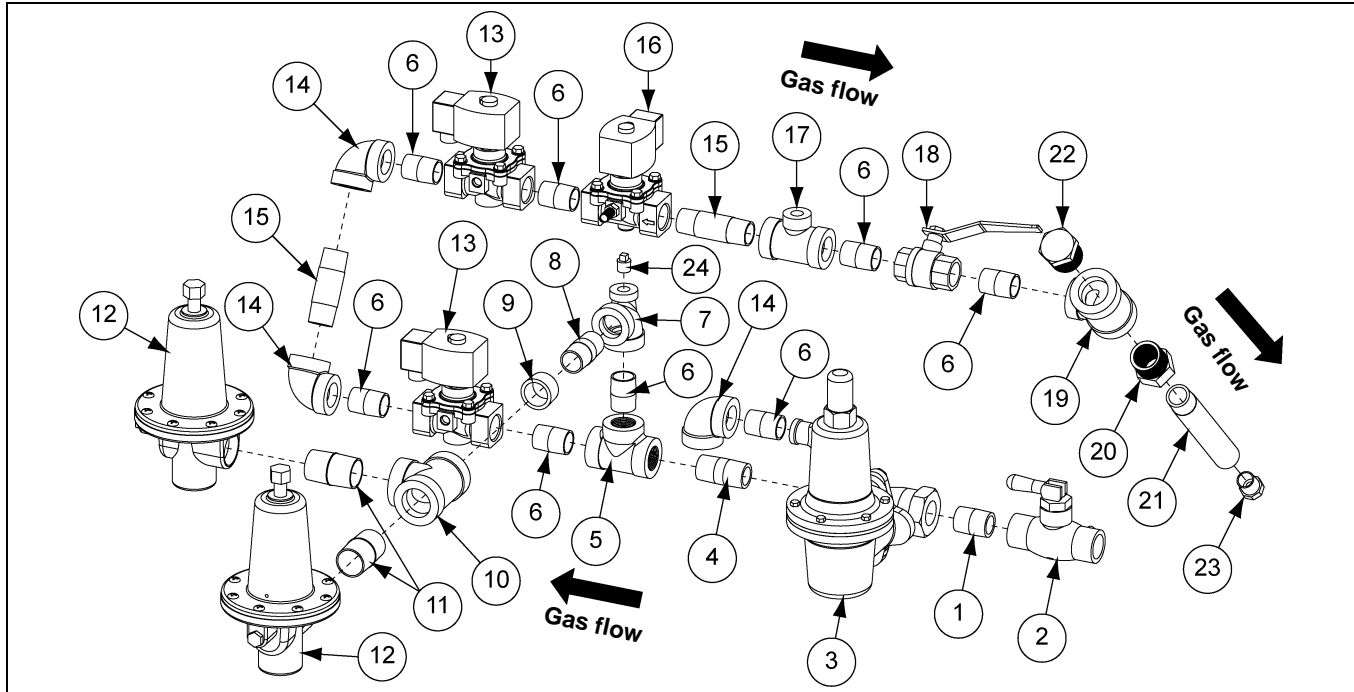

CSA 24" Propane Vapor LP High-Low Pipe Train Sub-Assembly (HF-8218) Parts List

Ref #	Part #	Description	Qty
1	D67-0021	Nipple, 3/4" Close SCH 80 Black	1
2	D03-0841	Valve, 3/4" NPT LP Quick Shut Off CSA	1
3	D03-0880	Regulator, LP 5-20 PSI Spring, 0.5 Orifice, 3/4" NPT	1
4	GT3-0743	Nipple, 3/4" x 2" SCH 40 Black	1
5	THH-4124	Tee, 3/4" x 3/4" x 3/4" SCH 40 Black	1
6	THH-4121	Nipple, 3/4" Close SCH 40 Black	8
7	THH-4158	Tee, 3/4" x 1/4" x 3/4" SCH 40 Black	1
8	THH-4125	Nipple, 3/4" x 2" SCH 40 Black	1
9	007-1338-8	Bushing, Flush 1" to 3/4"	1
10	THH-4137	Tee, 1" x 1" x 1" SCH 40 Black	1
11	007-1242-2	Nipple, 1" x 2" SCH 40 Black	2
12	D03-0881	Valve, Relief - 15-50 PSI Spring LP, 1" NPT, 300F Rating, Preset	2
13	056-2223-8	Valve, Solenoid 3/4" NPT 115V Din 50 PSI	2
14	THH-4120	Elbow, 3/4"-90° SCH 40 Black	3
15	THH-4136	Nipple, 3/4" x 3" SCH 40 Black	2
16	056-2228-7	Valve, Solenoid 3/4" NPT 115V Din Bypass 30 PSI Max ASCO Rebuild Kit	1
17	THH-4154	Tee, 3/4" x 3/4" x 1/4" SCH 40 Black	1
18	D03-0837	Valve, 3/4" NPT Full Port, Lever, CSA, Brass or Bronze	1
19	D08-0017	Tee, 1" x 1" x 3/4" SCH 40 Black	1
20	HF-7794	Orifice Holder - Quad Heater - 3/4"	1
21	HH-7027	Orifice Pipe, 3/4" x 6-1/2"	1
22	D08-0014	Plug, Hex-Head, Black Steel, 1" NPT	1
23	HF-7126	Orifice (3/4") Drilled 3/8"	1
24	007-1747-0	Plug, 1/4" NPT Square Black	1

8. Parts List

CSA 28" Propane Vapor LP High-Low Pipe Train Sub-Assembly (HF-8220)

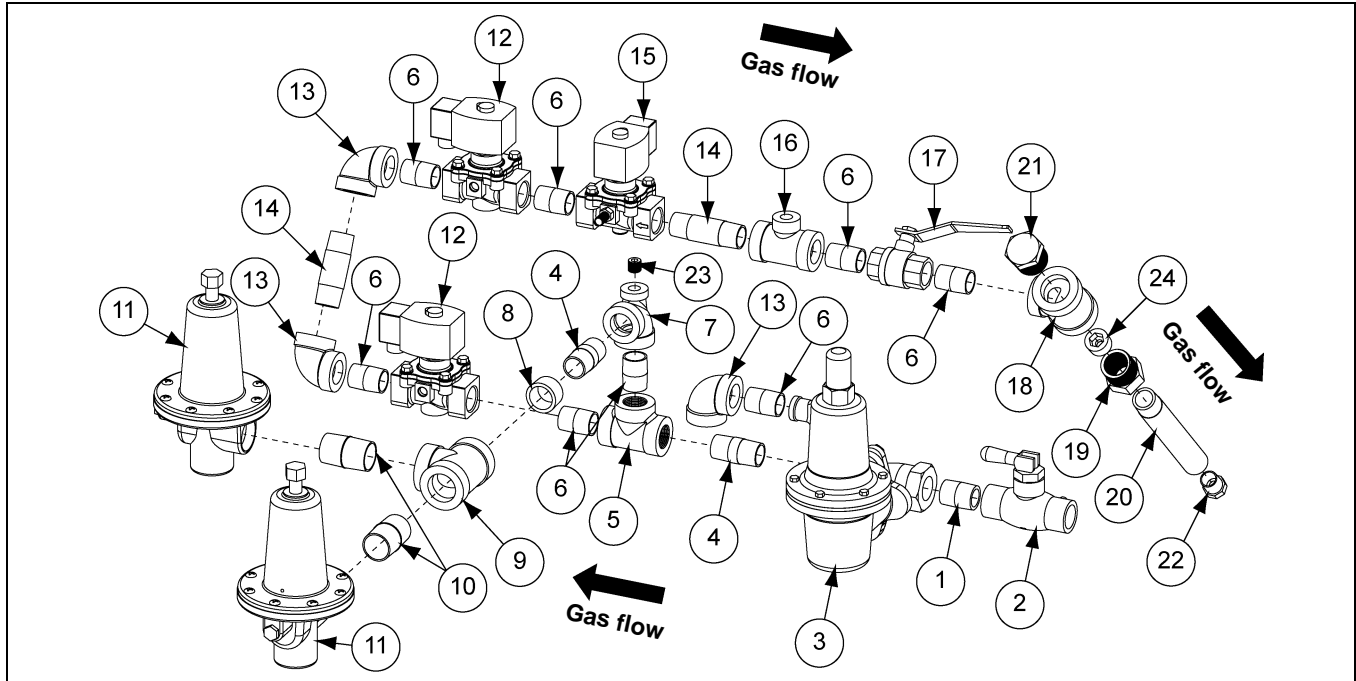

CSA 28" Propane Vapor LP High-Low Pipe Train Sub-Assembly (HF-8220) Parts List

Ref #	Part #	Description	Qty
1	D67-0021	Nipple, 3/4" Close SCH 80 Black	1
2	D03-0841	Valve, 3/4" NPT LP Quick Shut Off CSA	1
3	D03-0880	Regulator, LP 5-20 PSI Spring, 0.5 Orifice, 3/4" NPT	1
4	THH-4125	Nipple, 3/4" x 2" SCH 40 Black	2
5	THH-4124	Tee, 3/4" x 3/4" x 3/4" SCH 40 Black	1
6	THH-4121	Nipple, 3/4" Close SCH 40 Black	8
7	THH-4158	Tee, 3/4" x 1/4" x 3/4" SCH 40 Black	1
8	007-1338-8	Bushing, Flush 1" to 3/4"	1
9	THH-4137	Tee, 1" x 1" x 1" SCH 40 Black	1
10	007-1242-2	Nipple, 1" x 2" SCH 40 Black	2
11	D03-0881	Valve, Relief - 15-50 PSI Spring LP, 1" NPT, 300F Rating, Preset	2
12	056-2223-8	Valve, Solenoid 3/4" NPT 115V Din 50 PSI	2
13	THH-4120	Elbow, 3/4"-90° SCH 40 Black	3
14	THH-4136	Nipple, 3/4" x 3" SCH 40 Black	2
15	056-2228-7	Valve, Solenoid 3/4" NPT 115V Din Bypass 30 PSI	1
16	THH-4154	Tee, 3/4" x 3/4" x 1/4" SCH 40 Black	1
17	D03-0837	Valve, 3/4" NPT Full Port, Lever, CSA, Brass or Bronze	1
18	D08-0017	Tee, 1" x 1" x 3/4" SCH 40 Black	1
19	HF-7794	Orifice Holder - Quad Heater - 3/4"	1
20	HF-7539	Orifice Pipe 3/4" x 7"	1
21	D08-0014	Plug, Hex-Head, Black Steel, 1" NPT	1
22	HF-7126	Orifice (3/4") Drilled 3/8"	1
23	FLX-3788	Plug, 1/4" NPT Recessed Hex Galvanized	1
24	HF-7809	Orifice Plug (3/4") Drill: 5/16"	1

CSA Vapor/NG High-Low Pipe Train Assembly (HF-8381)

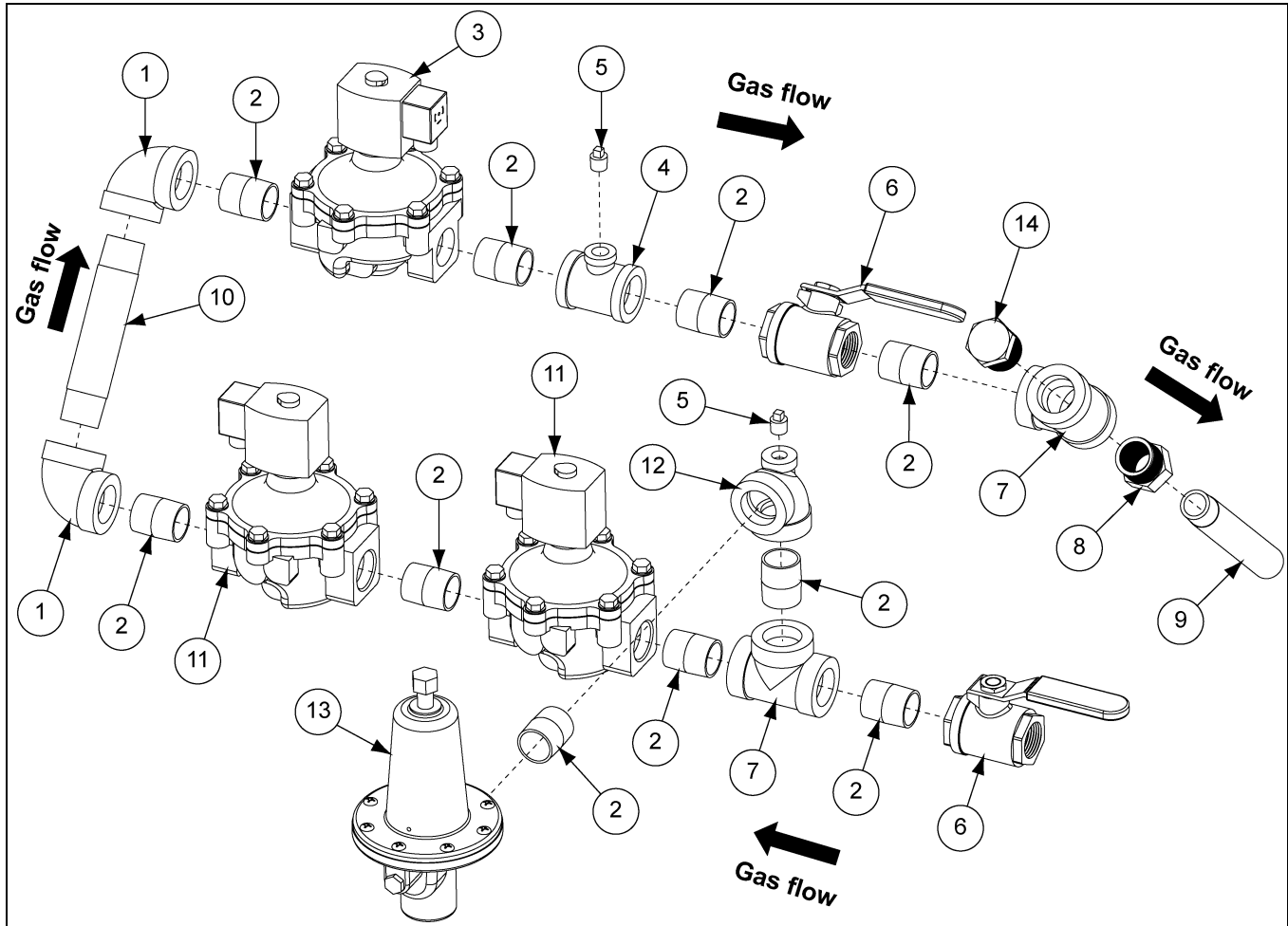

CSA Vapor/NG High-Low Pipe Train Assembly (HF-8381) Parts List

Ref #	Part #	Description	Qty
1	THH-4115	Elbow, 1"-90° SCH 40 Black	2
2	THH-4117	Nipple, 1" Close SCH 40 Black	10
3	056-2230-3	Valve, Solenoid 1" NPT 115V Din with Bypass 30 PSI Max ASCO Rebuild Kit	1
4	THH-4152	Tee, 1" x 1" x 1/4" SCH 40 Black	1
5	007-1747-0	Plug, 1/4" NPT Square Black	2
6	D03-0838	Valve, 1" NPT Full Port, Lever, CSA, Brass	2
7	THH-4137	Tee, 1" x 1" x 1" SCH 40 Black	2
8	HF-7794	Orifice Holder - Quad Heater - 3/4"	1
9	HF-7539	Orifice Pipe 3/4" x 7	1
10	THH-4116	Nipple, 1" x 6" SCH 40 Black	1
11	056-2224-6	Valve, Solenoid 1" NPT 115V Din 25 PSI Max ASCO Rebulid Kit #31891	2
12	THH-4163	Tee, 1" x 1/4" x 1" SCH 40 Black	1
13	D03-0881	Relief Valve - 15-50 PSI Spring LP, 1" NPT, 300F Rating, Preset	1
14	D08-0014	Plug, Hex-Head, Black Steel, 1" NPT	1

8. Parts List

CSA Vapor/NG Pipe Train Cycling (HF-8380)

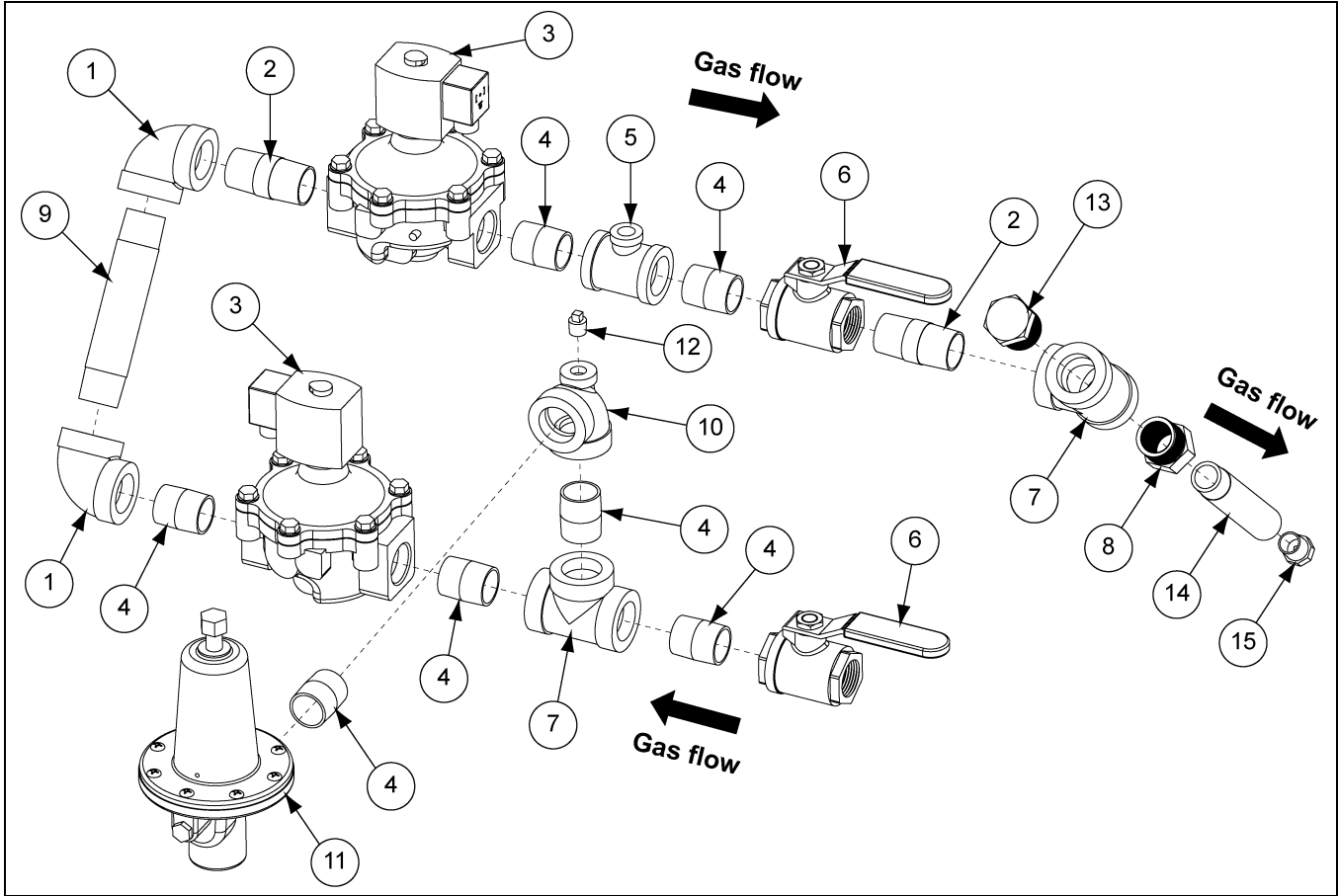

CSA Vapor/NG Pipe Train Cycling (HF-8380) Parts List

Ref #	Part #	Description	Qty
1	THH-4115	Elbow, 1"-90° SCH 40 Black	2
2	THH-4037	Nipple, 1" x 2-1/2" SCH 40 Black	2
3	056-2224-6	Valve, Solenoid 1NPT 115V Din 25 PSI Max ASCO Rebuild Kit #31891	2
4	THH-4117	Nipple, 1" Close SCH 40 Black	7
5	THH-4152	Tee, 1" x 1" x 1/4" SCH 40 Black	1
6	D03-0838	Valve, 1" NPT Full Port, Lever, CSA, Brass	2
7	THH-4137	Tee, 1" x 1" x 1" SCH 40 Black	2
8	HF-7794	Orifice Holder - Quad Heater - 3/4"	1
9	THH-4116	Nipple, 1" x 6" SCH 40 Black	1
10	THH-4163	Tee, 1" x 1/4" x 1" SCH 40 Black	1
11	D03-0881	Relief Valve - 15-50 PSI Spring LP, 1" NPT, 300F Rating, Preset	1
12	007-1747-0	Plug, 1/4" NPT Square Black	1
13	D08-0014	Plug, Hex-Head, Black Steel, 1" NPT	1
14	HH-7026	Orifice Pipe 3/4" x 5-1/2"	1
15	HF-7434	Orifice (3/4") Drilled 3/16"	1

CSA LP Supply Pipe Train Sub-Assembly (HF-8203)

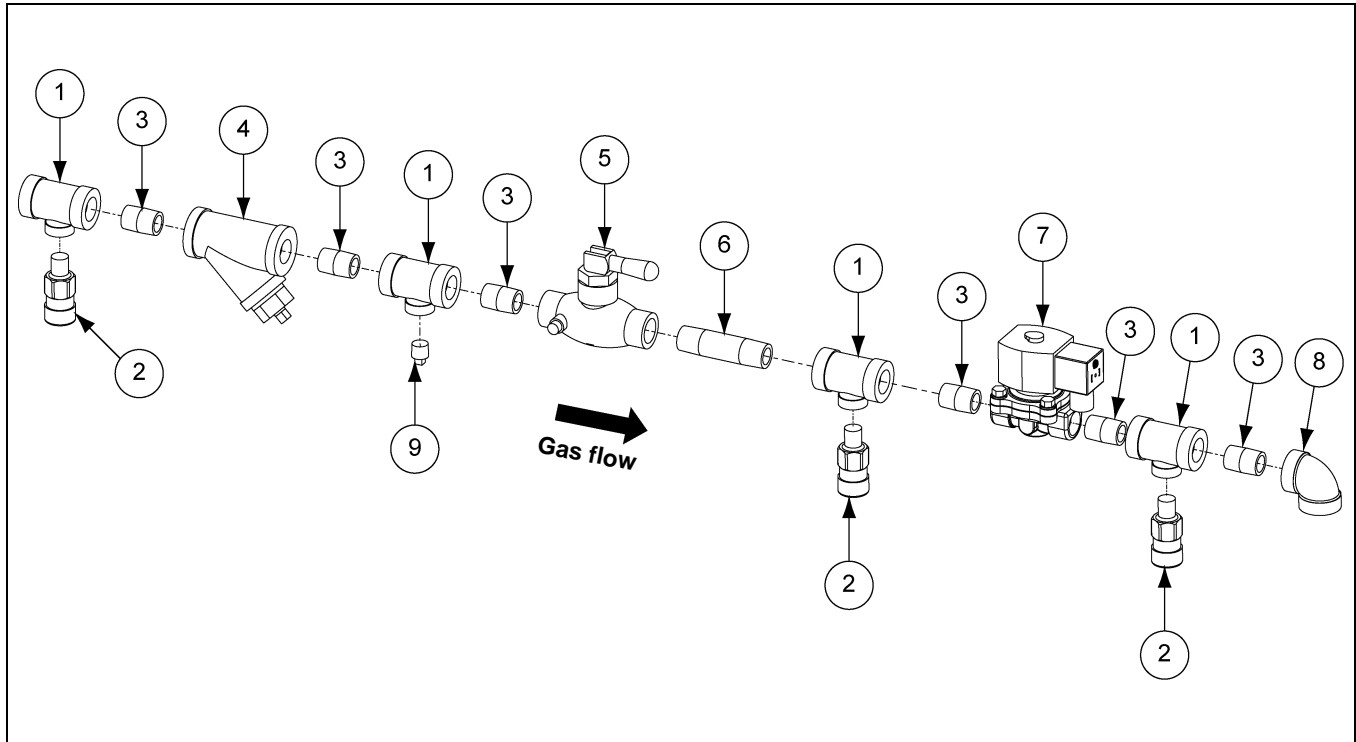

CSA LP Supply Pipe Train Sub-Assembly (HF-8203) Parts List

Ref #	Part #	Description	Qty
1	HH-4846	Tee, 1/2" x 1/2" x 1/4" SCH 80 Black	4
2	031-1008-7	Valve, Pressure Relief 300 PSI	3
3	THH-4113	Nipple, 1/2" Close SCH 80 Black	6
4	HH-1251	Strainer, 1/2" Y 250# WOG SCH 80 Black	1
5	D03-0840	Valve, 1/2" NPT LP Quick Shut-Off CSA	1
6	D07-0023	Nipple, 1/2" x 3" SCH 80 Black	1
7	TFC-0100	Valve, 1/2" NPT Solenoid LP with Din Connector 5-250 PSI	1
8	HH-4847	Elbow, 1/2"-90° SCH 80 Black	1
9	007-1747-0	Plug, 1/4" NPT Square Black	1

NOTES

GSI Group, LLC Limited Warranty

The GSI Group, LLC ("GSI") warrants products which it manufactures to be free of defects in materials and workmanship under normal usage and conditions for a period of 12 months after sale to the original end-user or if a foreign sale, 14 months from arrival at port of discharge, whichever is earlier. The end-user's sole remedy (and GSI's only obligation) is to repair or replace, at GSI's option and expense, products that in GSI's judgment, contain a material defect in materials or workmanship. Expenses incurred by or on behalf of the end-user without prior written authorization from the GSI Warranty Group shall be the sole responsibility of the end-user.

Warranty Extensions:

The Limited Warranty period is extended for the following products:

	Product	Warranty Period	
AP Fans and Flooring	Performer Series Direct Drive Fan Motor	3 Years	* Warranty prorated from list price: 0 to 3 years - no cost to end-user 3 to 5 years - end-user pays 25% 5 to 7 years - end-user pays 50% 7 to 10 years - end-user pays 75%
	All Fiberglass Housings	Lifetime	
	All Fiberglass Propellers	Lifetime	
AP and Cumberland	Flex-Flo/Pan Feeding System Motors	2 Years	
Cumberland Feeding/Watering Systems	Feeder System Pan Assemblies	5 Years **	** Warranty prorated from list price: 0 to 3 years - no cost to end-user 3 to 5 years - end-user pays 50%
	Feed Tubes (1-3/4" and 2.00")	10 Years *	
	Centerless Augers	10 Years *	
	Watering Nipples	10 Years *	
Grain Systems	Grain Bin Structural Design	5 Years	
Grain Systems Farm Fans Zimmerman	Portable and Tower Dryers	2 Years	† Motors, burner components and moving parts not included. Portable dryer screens included. Tower dryer screens not included.
	Portable and Tower Dryer Frames and Internal Infrastructure †	5 Years	

GSI further warrants that the portable and tower dryer frame and basket, excluding all auger and auger drive components, shall be free from defects in materials for a period of time beginning on the twelfth (12th) month from the date of purchase and continuing until the sixtieth (60th) month from the date of purchase (extended warranty period). During the extended warranty period, GSI will replace the frame or basket components that prove to be defective under normal conditions of use without charge, excluding the labor, transportation, and/or shipping costs incurred in the performance of this extended warranty.

Conditions and Limitations:

THERE ARE NO WARRANTIES THAT EXTEND BEYOND THE LIMITED WARRANTY DESCRIPTION SET FORTH ABOVE. SPECIFICALLY, GSI MAKES NO FURTHER WARRANTY OF ANY KIND, EXPRESS OR IMPLIED, INCLUDING, WITHOUT LIMITATION, WARRANTIES OF MERCHANTABILITY OR FITNESS FOR A PARTICULAR PURPOSE OR USE IN CONNECTION WITH: (I) PRODUCT MANUFACTURED OR SOLD BY GSI OR (II) ANY ADVICE, INSTRUCTION, RECOMMENDATION OR SUGGESTION PROVIDED BY AN AGENT, REPRESENTATIVE OR EMPLOYEE OF GSI REGARDING OR RELATED TO THE CONFIGURATION, INSTALLATION, LAYOUT, SUITABILITY FOR A PARTICULAR PURPOSE, OR DESIGN OF SUCH PRODUCTS.

GSI shall not be liable for any direct, indirect, incidental or consequential damages, including, without limitation, loss of anticipated profits or benefits. The sole and exclusive remedy is set forth in the Limited Warranty, which shall not exceed the amount paid for the product purchased. This warranty is not transferable and applies only to the original end-user. GSI shall have no obligation or responsibility for any representations or warranties made by or on behalf of any dealer, agent or distributor.

GSI assumes no responsibility for claims resulting from construction defects or unauthorized modifications to products which it manufactured. Modifications to products not specifically delineated in the manual accompanying the equipment at initial sale will void the Limited Warranty.

This Limited Warranty shall not extend to products or parts which have been damaged by negligent use, misuse, alteration, accident or which have been improperly/inadequately maintained. This Limited Warranty extends solely to products manufactured by GSI.

Prior to installation, the end-user has the responsibility to comply with federal, state and local codes which apply to the location and installation of products manufactured or sold by GSI.

This equipment shall be installed in accordance with the current installation codes and applicable regulations, which should be carefully followed in all cases. Authorities having jurisdiction should be consulted before installations are made.



**1004 E. Illinois St.
Assumption, IL 62510-0020
Phone: 1-217-226-4421
Fax: 1-217-226-4420
www.gsiag.com**



GSI is a worldwide brand of AGCO Corporation.