

# Downwind Series 2000 Centrifugal Heater Installation And Operating Instructions

MODEL # CH\_\_ - \_\_ \_\_ - \_\_ \_\_ - 2 \_\_ (HIGH)

MODEL # CL\_\_ - \_\_ \_\_ - \_\_ \_\_ - 2 \_\_ (LOW)

## Owner's Manual

PNEG-591



a division of  

---

THE GSI GROUP

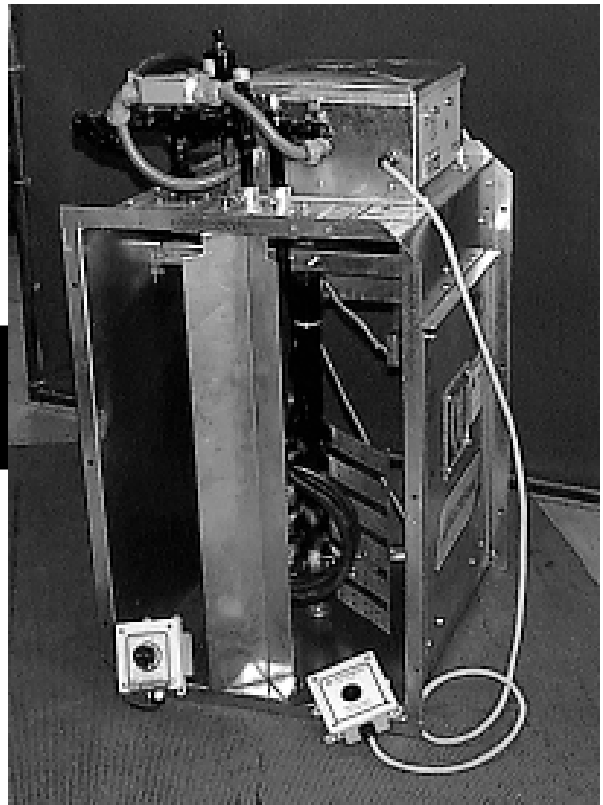



---

Safety .....	4
Series 2000 Heater Installation.....	6
High Temperature Heater Specifications.....	6
Low Temperature Heater Specifications.....	6
Air Pressure Switch and Temperature Sensor Box.....	7
Transition Hi-Limit Installation.....	7
Bin Configuration/Operating Temperature Table.....	8
Heater Unit Wiring.....	9
Secondary Heater Unit Wiring.....	9
Machine To Earth Ground.....	10
Proper Installation Of The Ground Rod.....	10
Previously Installed Units.....	10
Fuel Connection For Liquid Propane Models.....	11
Fuel Connection For Propane Vapor Models.....	11
Fuel Connection For Natural Gas Models.....	11
Installing Optional Humidity Sensor.....	12
Series 2000 Operating Procedure.....	13
Power Up.....	13
Normal Operating Displays With Heater Not Running.....	14
Starting The Dryer.....	15
Setting Gas Pressure .....	15
BTU's Per Gauge Pressure (PSI) 10-15 hp Models (Approximate).....	17
BTU's Per Gauge Pressure (PSI) 20-40 hp Models (Approximate).....	18
BTU's Per Gauge Pressure (PSI) Lo-temp Models (Approximate).....	20
Adjusting the Air Pressure Switch.....	21
Adjusting The Vaporizer.....	22
Running The Dryer.....	22
Programming Set Points.....	23
Programming Hours To Shutdown.....	24
Drying Grain In The Hours To Shutdown Mode.....	24
Run Hours Display.....	24
Multiple Heater Notes.....	24
Modulating Valve Operation.....	25
Factory Configuration.....	26
Configuration Dip Switches (Normally Done At GSI).....	26
Error Conditions.....	27
Limit Switches.....	27
Multiple Heater Error Conditions.....	27
Misc Error Numbers.....	27
Series 2000 Heater Service.....	28
Series 2000 Wiring Diagram.....	29
Series 2000 Heater Parts.....	30
10-15hp DW High Temp Heater.....	30
10-15hp DW Low Temp Heater.....	31
20-30hp DW High Temp Heater.....	32
20-30hp DW Low Temp Heater.....	33
40hp DW High Temp Heater.....	34
40hp DW Low Temp Heater.....	35
DW Heater Control Box.....	36
Air Switch Temperature Sensor Box.....	37
DW Propane Vapor Pipetrain.....	38
DW Natural Gas Pipetrain.....	39
DW Propane Vapor Hi-Lo Pipetrain.....	40
DW Natural Gas Hi-Lo Pipetrain.....	41
DW LP Pipetrain.....	42
Warranty.....	44

---

**SAFETY FIRST****General Safety Statements**

The GSI Group Inc's Principal concern is your safety and the safety of others associated with grain handling equipment. We want to keep you as a customer. This manual is to help you understand safe operating procedures and some problems which may be encountered by the operator and other personnel.

As owner and/or operator, it is your responsibility to know what requirements, hazards and precautions exist and inform all personnel associated with, or in the area of the product. Safety precautions may be required from the personnel. This product is ideal for the conditioning of corn, soy beans or other select grains. Avoid any alteration to the equipment, such alterations may produce a very dangerous situation, where serious injury or death may occur.



This is the safety alert symbol. It is used to alert you to potential personal injury hazards. Obey all safety messages that follow this symbol to avoid possible injury or death.



DANGER indicates an imminently hazardous situation which, if not avoided, will result in death or serious injury



WARNING indicates a potentially hazardous situation which, if not avoided, could result in death or serious injury.



CAUTION indicates a potentially hazardous situation which, if not avoided, may result in minor or moderate injury.



CAUTION used without the safety alert symbol indicates a potentially hazardous situation which, if not avoided, may result in property damage.

If a decal is damaged or missing contact:  
 The GSI Group Inc.  
 1004 E. Illinois St.  
 Assumption, IL 62510  
 217-226-4421  
 A free replacement will be sent to you.

**BE ALERT!  
Danger!**

Personnel operating or working around electrical equipment should read this manual. This manual must be delivered with equipment to its owner. Failure to read this manual and its safety instructions is a misuse of the equipment.

The GSI Group Inc. recommends that you contact your local power company and have a representative review your installation so your wiring will be compatible with their system and so that you will have adequate power supplied to your unit.

**Roof Damage Warning And Disclaimer**

**⚠ CAUTION!**

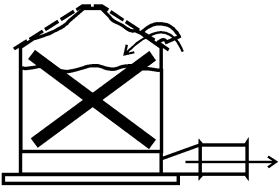

Excessive vacuum (or pressure) may damage roof. Use positive aeration system. Make sure all roof vents are open and unobstructed. Start roof fans when supply fans are started. Do not operate when conditions exist that may cause roof vent icing.

DC-989

GSI DOES NOT WARRANT ANY ROOF DAMAGE CAUSED BY EXCESSIVE VACUUM OR INTERNAL PRESSURE FROM FANS OR OTHER AIR MOVING SYSTEMS. ADEQUATE VENTILATION AND/OR "MAKEUP AIR" DEVICES SHOULD BE PROVIDED FOR ALL POWERED AIR HANDLING SYSTEMS. GSI DOES NOT RECOMMEND THE USE OF DOWNWARD FLOW SYSTEMS (SUCTION). SEVERE ROOF DAMAGE CAN RESULT FROM ANY BLOCKAGE OF AIR PASSAGES. RUNNING FANS DURING HIGH HUMIDITY/COLD WEATHER CONDITIONS CAN CAUSE AIR EXHAUST OR INTAKE PORTS



**⚠ WARNING**

Stay clear of rotating blade. Blade could start automatically. Can cause serious injury. Disconnect power before servicing.

DC-1225



**⚠ WARNING**

Flame and pressure beyond door. Do not operate with service door removed. Keep head and hands clear. Can cause serious injury.

DC-1227

**⚠ DANGER!**



**High voltage. Will cause serious injury or death. Lockout power before servicing.**

DC-1224

**⚠ DANGER**



Rotating flighting can kill or dismember.



Flowing material can trap and suffocate.



Crusted material can collapse and suffocate.

**Keep clear of all augers. DO NOT ENTER this bin!**

If you must enter this bin:

1. Shut off and lock out all power.
2. Use safety harness and safety line.
3. Station another person outside the bin.
4. Avoid the center of the bin.
5. Wear proper breathing equipment or respirator.

**Failure to heed these warnings will result in serious injury or death.**

DC-552

**Centrifugal Heater Specifications**

		Hi-Temp 10-15HP	Hi-Temp 20-40HP	Lo-Temp Model All units
All Models	BTU Rating	2225000	4500000	500000
	Weight	145	145	135
Liquid Models	Maximum Fuel flow (GPH)	24	49	N/A
	Orifice size	0.2188	0.3125	N/A
	Mod Valve Bypass Orifice	Blue	Aluminum	Yellow
	Minimum operating pressure	1	1	N/A
	Maximum operating pressure	15	15	N/A
	Minimum line size	3/8"	3/8"	N/A
Vapor Models	Maximum Fuel flow (CFH)	931	1898	210
	Orifice size	0.2188	0.3125	0.109
	Mod Valve Bypass Orifice	Blue	Aluminum	Yellow
	Minimum operating pressure	1	1	1
	Maximum operating pressure	15	15	15
	Minimum line size	3/8"	3/8"	1/2"
Natural Gas Models	Maximum Fuel flow (CFH)	2496	4643	500
	Orifice size	0.3438	0.4688	0.156
	Mod Valve Bypass Orifice	Aluminum	Aluminum	Green
	Minimum operating pressure	0.5	0.5	1
	Maximum operating pressure	7	7	7
	Minimum line size	1.1/4"	1.1/4"	1"

**Heater Dimensional Specifications**

Heater Size	10-15	20-30	40
Inside Height	30.1/4"	33.1/4"	33.1/4"
Inside Width	19.1/2"	21.3/4"	23.11/16"
Inside length	24"	24"	24"

### Air Pressure Switch and Temperature Sensor Box Installation

1. Using air switch box as a guide, mark 2 holes on plenum side wall approximately 24" to right of transition centered up and down in plenum.
2. Drill air switch filter hole 5/8" diameter for snug fit. Drill temperature sensor hole 5/8" or larger to accommodate mounting nut.
3. Mount Box to Bin using (4) self drilling screws
4. Caulk between housing and side-wall to seal.

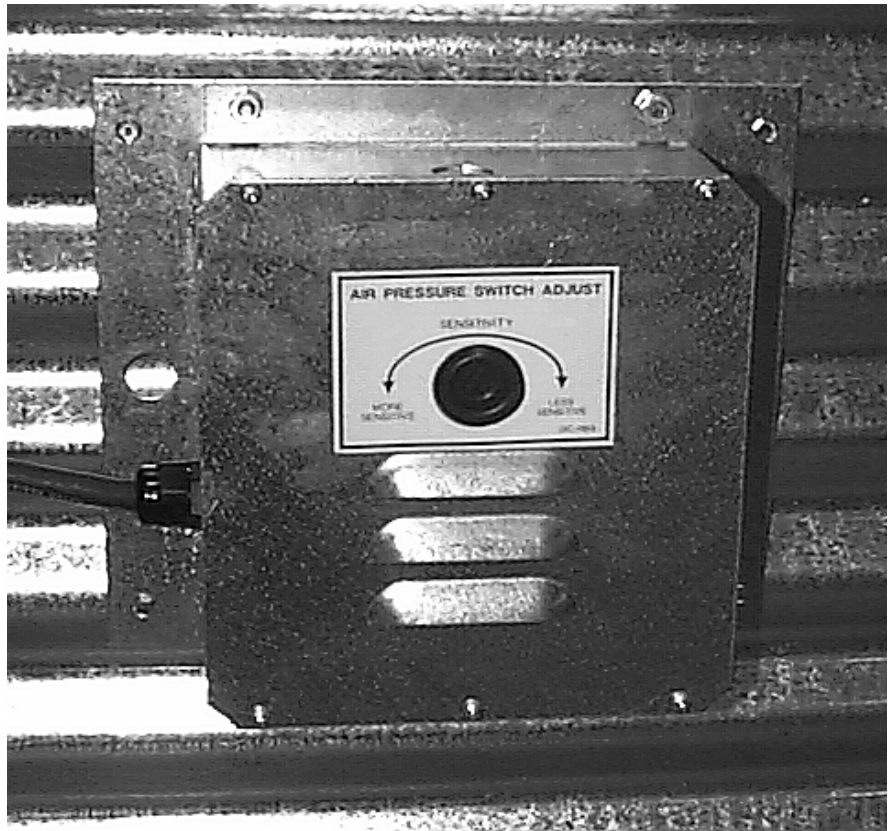

Air Switch Box Assembly

### Transition Hi-limit Installation

1. Mark location on transition one (1) foot up from the bottom (entrance collar) and centered in the transition.
2. Drill or knock out 7/8" diameter hole on marked location.
3. Install transition hi-limit using supplied self drilling screws.

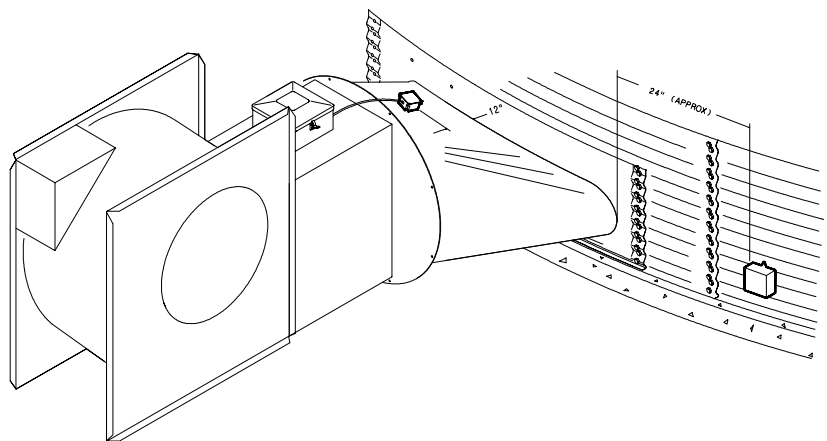
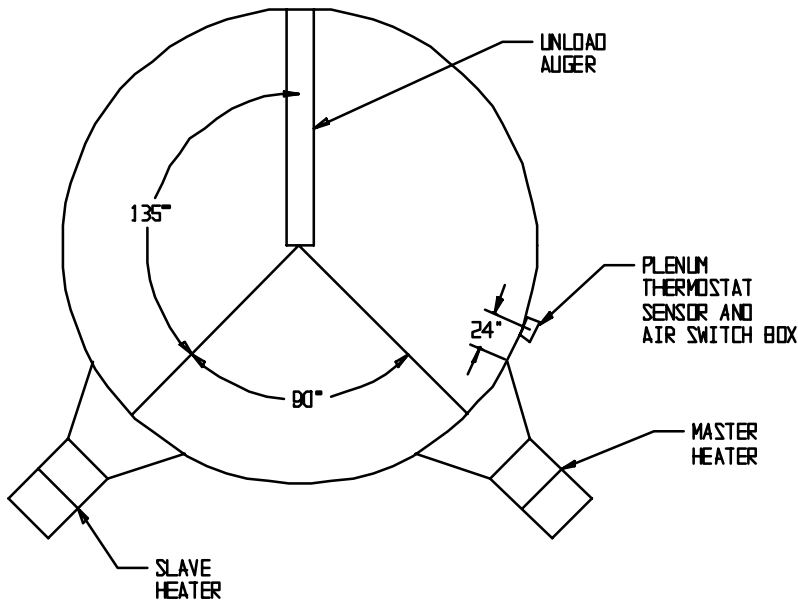

Figure 1: The transition connecting the Series 2000 Heater to the bin with the sensor in place.

**Bin Configuration**



**IMPORTANT!** When mounting (2) heaters on a bin it is imperative that they be situated as illustrated in this drawing. Plenum thermostat must be to the right of master heater and master heater must be to the right of slave heater.

**THIS TABLE IS NOT INTENDED AS A DRYING GUIDE. IT SHOULD BE USED AS A REFERENCE FOR SETTING MAXIMUM PLENUM TEMPERATURE FOR SAFE OPERATION.**

**Operating Temperature Table**

	LO-TEMP BATCH	HIGH-TEMP BATCH DRY NO STIRRING	HIGH-TEMP WITH STIRRING	CONTINUOUS FLOW (RECIRCULATING)
CORN	5-20° ABOVE AMBIENT TEMP	120°	140°	160°
RICE	5-10° ABOVE AMBIENT TEMP	100°	100°	NOT RECOMMENDED
BEANS & WHEAT	5-20° ABOVE AMBIENT TEMP	110°	120°	NOT RECOMMENDED

**IMPORTANT! DO NOT EXCEED PLENUM TEMPERATURES LISTED IN TABLE**



**Heater Unit**

1. Be sure fan unit is installed and wired to meet local codes. Be sure equipment is well grounded (see page 10).
2. A separate neutral is required for 120 volt heater circuit in 220 volt 1PH and 3PH fan units. For 460 volt fan units a separate 120 volt power supply or transformer is required.
3. Run 5-wire black cord from heater unit to fan unit and secure to fan.
4. Orange and red wires should be connected in series with coil in fan. When contacts in heater between these wires open fan

**Wiring**

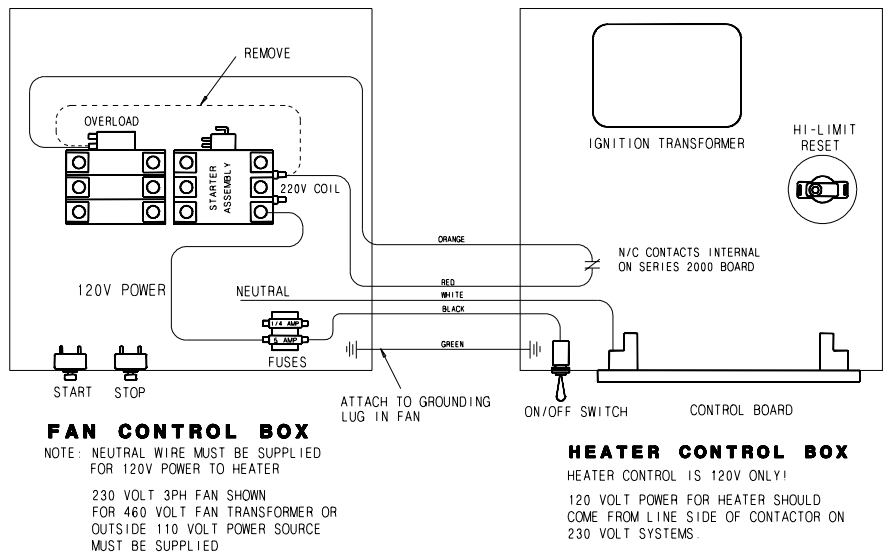

**Figure 2: Wiring diagram for the fan and heater unit.**

shuts down. Recommended wiring is shown in Figure 2.

5. Black and white wires should be connected to a fused 120V power supply as shown. Green wire should be connected to ground in fan. Heater should have power, even with fan off.

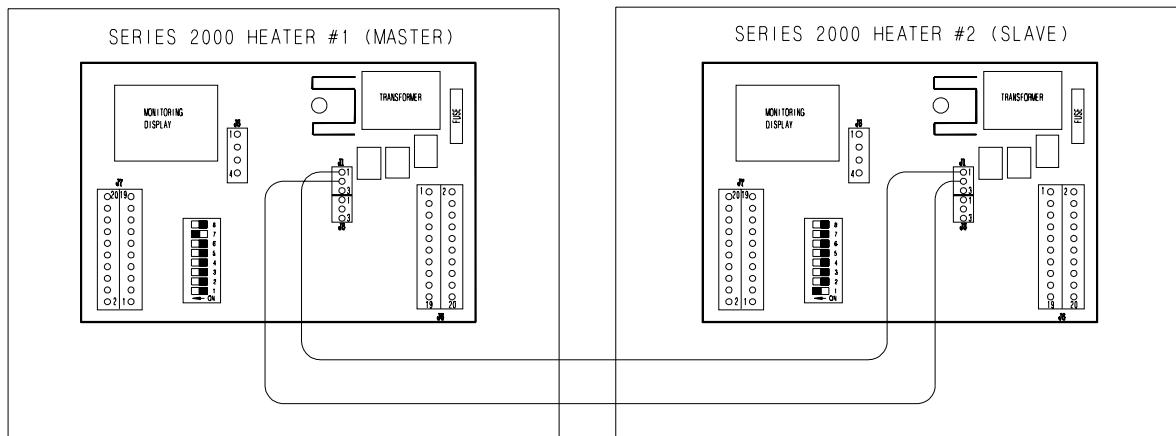

**Figure 3: Secondary heater wiring diagram.**

**SECONDARY HEATER UNIT**

1. Secondary heater unit runs as a slave of heater unit #1 and requires no plenum temperature sensor.
2. Run (2) 20 gauge (minimum) wires from secondary heater unit (slave) to heater unit #1

(master).

3. Connect wires as shown in Figure 3.
4. Third heater unit may also be added to system. If adding third unit, run connections to master unit #1 and connect them in parallel with secondary heater unit.

### Machine To Earth Ground

It is very important that a machine to earth ground rod be installed at the fan. This is true even if there is a ground at the pole 15 feet away. This ground needs to be as close to the fan as possible, but no more than 8 feet away. The ground rod should be connected to the fan control panel with at least a #6 solid bare copper ground wire, or in accordance with local requirements. The machine to earth ground provides additional safety if there is a short. It also provides the grounding necessary for long life and operation of the solid state circuit boards used on control circuits and the electronic ignition systems.



**Dig a hole large enough to hold 1 or 2 gallons of water. Work the ground rod into the earth until it is completely in the ground.**

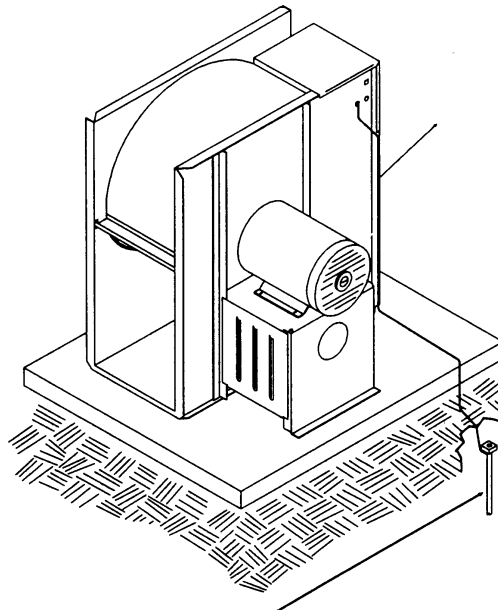

**Figure 4: Use a #6 or approved size bare copper ground wire. Install a 5/8" diameter 8' long copper-clad ground rod, 2' away from the foundation and 1' below the surface of the ground or in accordance with local requirements.**

### Proper Installation Of The Ground Rod

(Ground rods and wires are not supplied by Airstream). It is recommended that the rod not be driven into dry ground. The following steps ensure proper ground rod installation:

1. Dig a hole large enough to hold 1 to 2 gallons of water.
2. Fill hole with water.
3. Insert rod through water and jab it into the ground.
4. Continue jabbing the rod up and down, the water will work its way down the hole, making it possible to work the rod completely into the ground. This method of installing the rod gives a good conductive bond with the surrounding soil.
5. Connect the bare copper ground wire to the rod with the proper ground rod clamp.
6. Connect the bare ground wire to the fan control boxes with a grounding lug. See figure 4.
7. Ground wire must not have any breaks or splices. Insulated wire is not recommended for grounding.

### Previously Installed Units

It is recommended that previously installed units be checked to see that a machine to earth ground has been installed by an electrician.

<p>Standard electrical safety practices and codes should be used when working with a heater. Refer to the National Electric Code Standard Handbook by the National Fire Protection Association. <i>A qualified electrician should make all wiring installations.</i></p>	 <p><b>ALWAYS DISCONNECT AND LOCK OUT POWER BEFORE WORKING ON OR AROUND HEATER</b></p>	<p><b>IMPORTANT!</b> Do not use propane tanks that have previously been used for ammonia unless they have been purged according to procedures of the National L.P. Association.</p> <p>Fuel supply system must comply with local codes for L.P. gas installation.</p>
--	---	---

**Fuel Connection**

**Liquid Propane Models**

1. L.P. models are designed to run on liquid propane with liquid draw from the propane tank. Avoid using propane supply tanks that have been used for vapor draw for long periods of time. When using liquid draw systems any moisture that may be present in tank or lines may freeze when system is used in cold weather. To avoid this situation, purge the system with methanol.
2. Run proper size line (see specification on page 7) to liquid pipetrain on heater. Have a qualified gas service person inspect installation to be sure that everything is installed according to local codes and ordinances.
3. After installation is complete check all connections for leaks with liquid detergent or comparable. Wear rubber gloves and eye protection. Avoid contact with liquid propane. **DO NOT USE FLAME FOR LEAK TESTING.**

**Propane Vapor Models**

1. Propane vapor models are designed to run directly off of a supply tank or from a separate

external vaporizer.

2. Run proper size line (see specifications on page 7) to pipetrain on heater. Have a qualified gas service person inspect installation to be sure that everything is installed according to local codes and ordinances.
3. After installation is complete check all connections for leaks. **DO NOT USE FLAME FOR LEAK TESTING.**

**Natural Gas Models**

1. Natural gas models are designed to run directly off of a supply tank or from a separate external vaporizer.
2. Run proper size line (see specification on page 7) to pipetrain on heater. Have a qualified gas service person inspect installation to be sure everything is installed according to local codes and ordinances.
3. After installation is complete check all connections for leaks. **DO NOT USE FLAME FOR LEAK TESTING.**



Figure A

### Installing Optional Humidity Sensor

1. Humidity sensor should be mounted 6-8" right of the airswitch/temperature sensor box. See Figure A.
2. Using sensor as a guide drill or knock-out 7/8" diameter hole in the center of the plenum on the bin sidewall. If you are using sensor to sense drying air humidity.
3. Insert pipe nipple from sensor housing through hole in side wall and use self-drilling screws to mount to sidewall. Figure B
4. Do not caulk sensor box openings on side of box, they are for air escape.

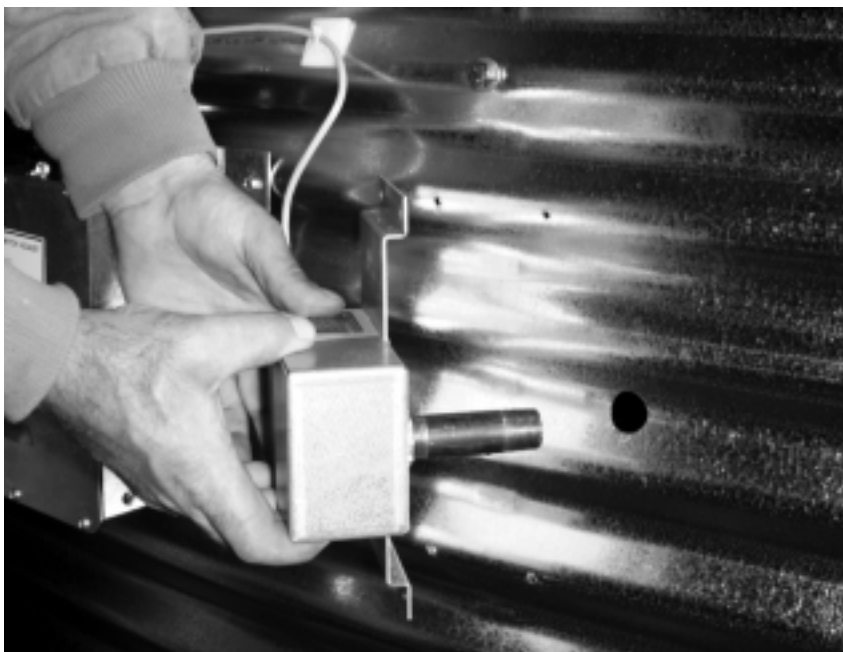
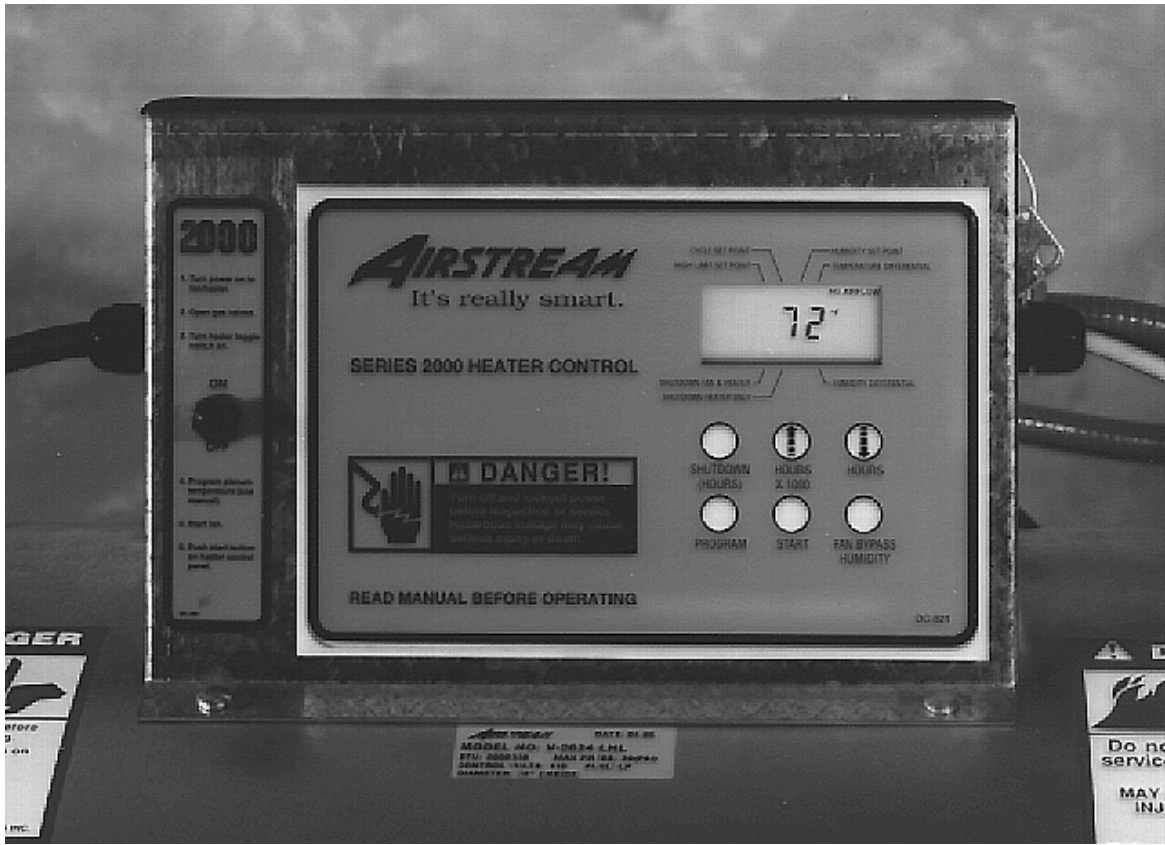

Figure B



The control panel display showing initial start up.

Standard electrical safety practices and codes should be used when working with a heater. Refer to the National Electric Code Standard Handbook by the National Fire Protection Association. A *qualified electrician should make all wiring installations.*

**ALWAYS DISCONNECT AND LOCK OUT POWER BEFORE WORKING ON OR AROUND HEATER**



**Power Up**

All safety and high limit switches are checked upon power up. If a safety or limit is open, the control displays it. The control cannot operate with a safety switch error, and the fan cannot turn on with an error condi-

tion. There is no way to bypass an error condition. It must be fixed. (See errors on page 21)

The air switch is also checked on power up. The air switch must indicate no airflow. This is necessary to check the function of the air switch. However, if the operator forgets and turns the fan on before the controller has been powered up, The controller locks up with the main display alternating between a "FAN" and "ON" message. This may be bypassed by depressing and holding the "FAN BYPASS" switch (lower right switch). Normal operating procedure should be to power up the controller with the fan off.

If multiple heaters are tied together, and the master detects that the slave fan is on (the air switch stuck?), the master will lock up displaying "SLA ERROR". This condition may be bypassed with the "FAN BYPASS" switch.

## Normal Operating Displays With Heater Not Running

The main display shows the plenum temperature. If the dryer has not been running, the display should show outside temperature. The control is preset at the factory to display temperature in centigrade or fahrenheit.

"AIRFLOW" or "NO AIRFLOW" is displayed if air is flowing or not flowing. "RX TX" (receive, transmit) is displayed if multiple heaters are connected.

All safeties or high limits are continuously checked during the off mode. A limit switch open,

or any other error condition will cause the display to show the limit or error condition.

When drying is not occurring, and the limit or error condition is corrected, the display returns to its normal output. This is not the case with an error or limit condition during the drying operation. This causes the display to lock up in the error display mode. This is to keep the display locked up with the condition illuminated. ( see section on "Running the Dryer" for mode explanation on page 17).



The heater display with fan on (airflow).

### Starting The Dryer

After heater power is turned on, the fan must be turned on. Attempting to start the dryer without the air switch indicating there is airflow will cause an air-flow alarm to go off when the start switch is depressed. The airflow alarm is simply the entire display going blank, and the "NO AIRFLOW" message flashing for a few seconds. The display must show "AIRFLOW" before the dryer can be started.

To start the dryer, just push the "START" switch. The first message to come up will be the "PURGE" message--the drying process begins with a 10 second purge.

When multiple heaters are connected together, drying may be started from any heater control.

### Setting Gas Pressure

1. At heater turn toggle switch to "ON" position.
2. Press the "PROGRAM TEMPERATURE" button.
3. Use the increase or decrease button to set the "PLENUM HIGH LIMIT SET POINT" to desired setting (100°-160°\*).
4. Press the "PROGRAM TEMPERATURE" button to continue to set the "CYCLE SETPOINT". (hi-lo units only)
5. Use the increase or decrease buttons to set the "CYCLE SET POINT" to desired setting (90°-150°\*) (hi-lo units only).
6. Press "programs temperature" button to continue to set the desired "relative humidity" setting, lower setting will run heater longer. (humidity sensor units only) Use arrow keys to set.



**Programming the temperature differential.**

7. Press the "PROGRAM TEMPERATURE" button to continue to set the "TEMPERATURE DIFFERENTIAL".
8. Use the increase or decrease buttons to set the "TEMPERATURE DIFFERENTIAL" to 10°\*.
9. Press "program temperature" button to continue to set "relative humidity differential". Use arrow keys to adjust to 5%. (Humidity sensor units only).
10. Open all manual gas shut off valves, on and to the heater unit.
- 11 Start the fan unit.
12. Make sure that the blade is spinning in the right direction. If not place the toggle switch in the "OFF" position and correct the problem.
13. After the fan reaches full speed the display should read "AIRFLOW" in the upper right hand corner. If not adjust air switch. (See page 19)
14. Press the start button on the heater control.
15. After 10 seconds the burner should ignite. If not, turn "OFF" the toggle switch and then back "ON". Repeat 12-15.

\*Temperatures are fahrenheit.

16. When the burner ignites the display should read "HI-FLAME " at the left of the display. Loosen the nut on the main regulator and turn screw in, to increase pressure and out to decrease pressure. The pressure gauges should be set at 10-15 lbs. for LP units, or 4-6 lbs.. for natural gas units. (use the charts on the following pages to set pressure)
17. Press the "PROGRAM TEMPERATURE" button to change the high limit set point. Press it again to change the "CYCLE SET POINT". (hi-lo units only)
18. Decrease the "CYCLE SET POINT TEMPERATURE" until the heater cycles to low flame. (hi-lo units only)
19. Open or close the low cycle ball valve until the gas pressure is 3-5 lbs. for LP, or 1-2 lbs. for natural gas. (hi-lo units only)
20. Increase the cycle set point to return to high flame. (hi-lo units only)
21. Watch heater run several minutes to make sure it cycles between hi and lo flame or on and off properly.
22. Hi-flame pressure should be adjusted so plenum reaches cycling temperature easily.
23. Adjust pressure on on/off units so that unit is on approximately 75% of the time.





**10-15 hp Units**

**BTUs Per Gauge Pressure (psi) PROPANE MODELS (Approximate)**

High Temperature 10-15hp 7/32" (0.219") Orifice  
OPERATING PRESSURE (psi)

	2	4	6	8	10	12	14	15
ALL MODELS	816,013	1,148,640	1,409,477	1,632,026	1,825,859	1,995,762	2,153,700	2,227,883

Gauge Pressure (psi) Required to Maintain Temperature (Approximate)  
(10-15 hp High Temperature Propane Units Only)

Fan Model	Static Pressure	Heat Rise (°F)						
		60	80	100	120	140	160	180
10 hp	2"	2	4	6	8	10	13	
	4"	1	3	5	6	8	11	14
	6"	1	1	3	5	6	8	10
15 hp	2"	3	6	9	12	15		
	4"	3	5	7	10	13		
	6"	2	3	5	6	9	11	14

**10-15 hp Units**

**BTUs Per Gauge Pressure (psi) NATURAL GAS MODELS (Approximate)**

High Temperature 10-15hp 11/32" (0.344") Orifice  
OPERATING PRESSURE (psi)

	1	2	3	4	5	6	7
ALL MODELS	859,104	1,218,432	1,489,296	1,718,208	1,921,584	2,107,632	2,276,352

Gauge Pressure (psi) Required to Maintain Temperature (Approximate)  
(10-15 hp High Temperature Natural Gas Units Only)

Fan Model	Static Pressure	Heat Rise (°F)						
		60	80	100	120	140	160	180
10 hp	2"	1	1.75	2.5	3.5	4.75	6	
	4"	0.75	1.25	2	2.75	3.75	4.75	6
	6"	0.5	1	1.5	2	2.75	3.5	4.25
15 hp	2"	1.5	2.5	3.75	5.5			
	4"	1.25	2	3	4.25	5.75		
	6"	0.75	1.25	2	2.75	3.75	5	6

**20-40 hp Units**

**BTUs Per Gauge Pressure (psi) PROPANE MODELS (Approximate)**

High Temperature 20-40hp 5/16" (0.313") Orifice  
 OPERATING PRESSURE (psi)

	2	4	6	8	10	12	14	15
ALL MODELS	1,663,135	2,345,140	2,878,779	3,328,663	3,721,115	4,068,100	4,393,548	4,541,914

Gauge Pressure (psi) Required to Maintain Temperature (Approximate)  
 (20-40 hp High Temperature Propane Units Only)

Fan Model	Static Pressure	Heat Rise (°F)						
		60	80	100	120	140	160	180
20 hp	2"	2	2	4	5	7	8	10
	4"	1	2	3	4	5	7	8
	6"	1	2	3	4	5	6	7
25 hp	2"	2	3	5	7	9	12	15
	4"	2	3	4	6	8	10	13
	6"	2	2	4	5	6	8	10
30 hp	2"	2	4	6	8	11	15	
	4"	2	4	5	7	10	13	
	6"	2	3	4	6	8	10	13
40 hp	2"	3	6	8	12			
	4"	3	5	7	11	14		
	6"	3	4	7	9	12		

**20-40 hp Units**

**BTUs Per Gauge Pressure (psi) NATURAL GAS MODELS (Approximate)**

High Temperature 20-40hp 15/32" (0.469") Orifice  
 OPERATING PRESSURE (psi)

	1	2	3	4	5	6	7
ALL MODELS	1,597,824	2,266,320	2,770,656	3,195,648	3,573,216	3,919,776	4,234,416

Gauge Pressure (psi) Required to Maintain Temperature (Approximate)  
 (20-40 hp High Temperature Natural Gas Units Only)

Fan Model	Static Pressure	Heat Rise (°F)						
		60	80	100	120	140	160	180
20 hp	2"	0.75	1.25	1.75	2.5	3.25	4.25	5.5
	4"	0.5	1	1.5	2	2.75	3.5	4.5
	6"	0.5	0.75	1.25	1.75	2.25	3	3.75
25 hp	2"	1	1.75	2.25	3.5	4.75	6.25	
	4"	0.75	1.5	2.25	3.25	4	5.25	6.25
	6"	0.5	1.25	1.75	2.5	3.25	4.25	5.5
30 hp	2"	1.25	2	3	4.5	6		
	4"	1	1.75	2.75	3.75	5	7	
	6"	0.75	1.5	2.25	3	4	5.25	7
40 hp	2"	1.75	3	4.5	6.25			
	4"	1.5	2.5	4	5.5			
	6"	1.25	2.25	3.5	4.75	6.75		

**Lo-Temp Units**  
**BTUs Per Gauge Pressure (psi)**  
**PROPANE MODELS**  
**(Approximate)**

Low Temperature All hp 7/64" (0.109") Orifice  
OPERATING PRESSURE (psi)

	2	4	6	8	10	12	14	15
ALL MODELS	203,405	287,160	351,771	409,203	457,063	497,744	538,425	555,176

**Lo-Temp Units**  
**BTUs Per Gauge Pressure (psi)**  
**NATURAL GAS MODELS**  
**(Approximate)**

Low Temperature All hp 5/32" (0.156") Orifice  
OPERATING PRESSURE (psi)

	1	2	3	4	5	6	7
ALL MODELS	177,840	251,712	308,256	355,680	397,632	435,936	470,592

### Adjusting the Air Pressure Switch

1. Air pressure switch must be adjusted so that it will activate with lowest level of grain that will be dried in bin.
2. Put grain in bin to level desired (low).
3. With heater on and fan off display on heater should read "no airflow".
4. Start fan. Heater display should now read "airflow".
5. If display does not read "airflow" remove cap from adjustment port and slowly turn screw counter clockwise until display does read "Airflow". Figure C
6. Shut fan off display should read "no air flow" when fan gets to half speed. If not repeat step 5.

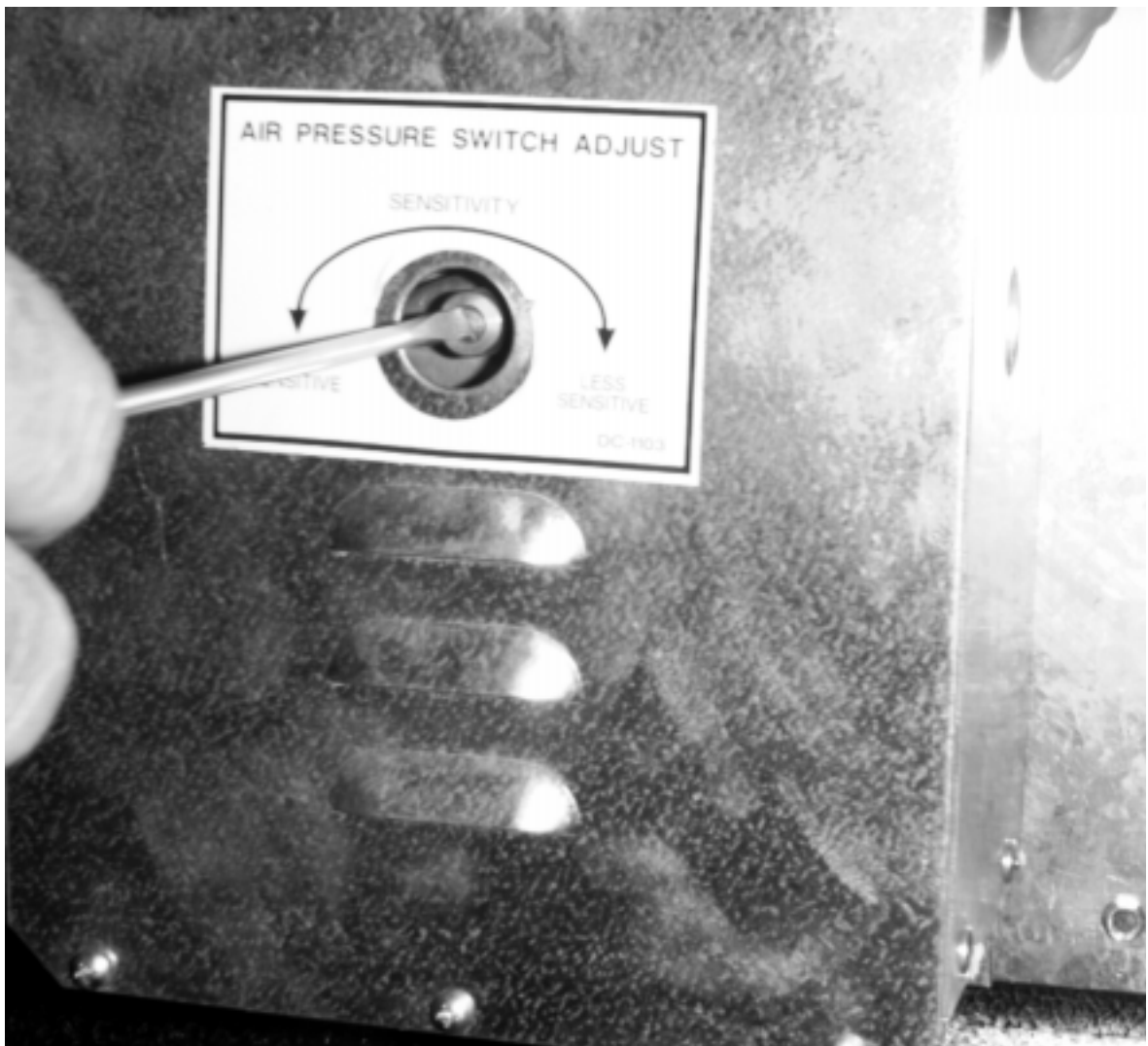
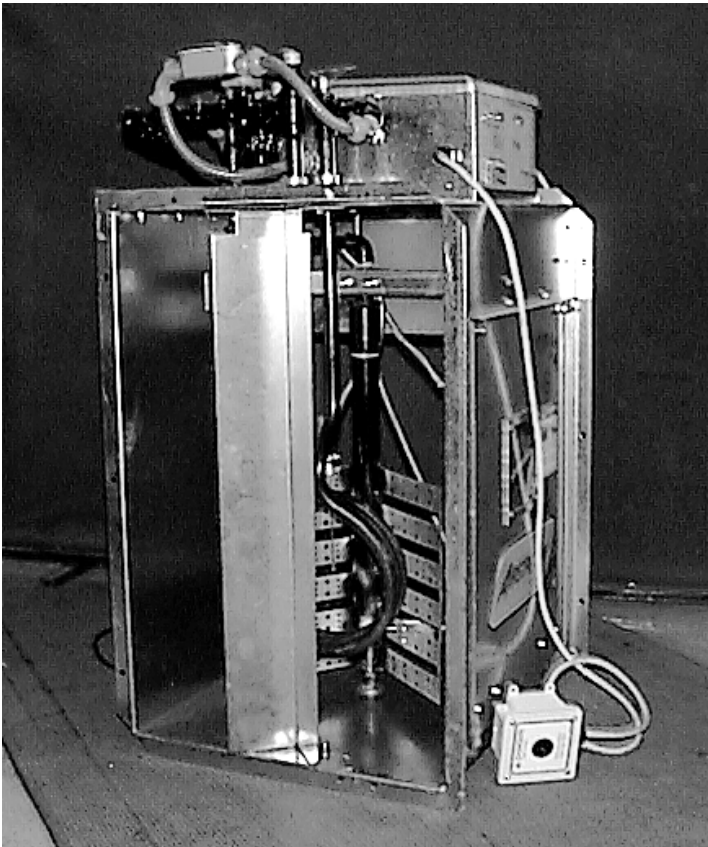
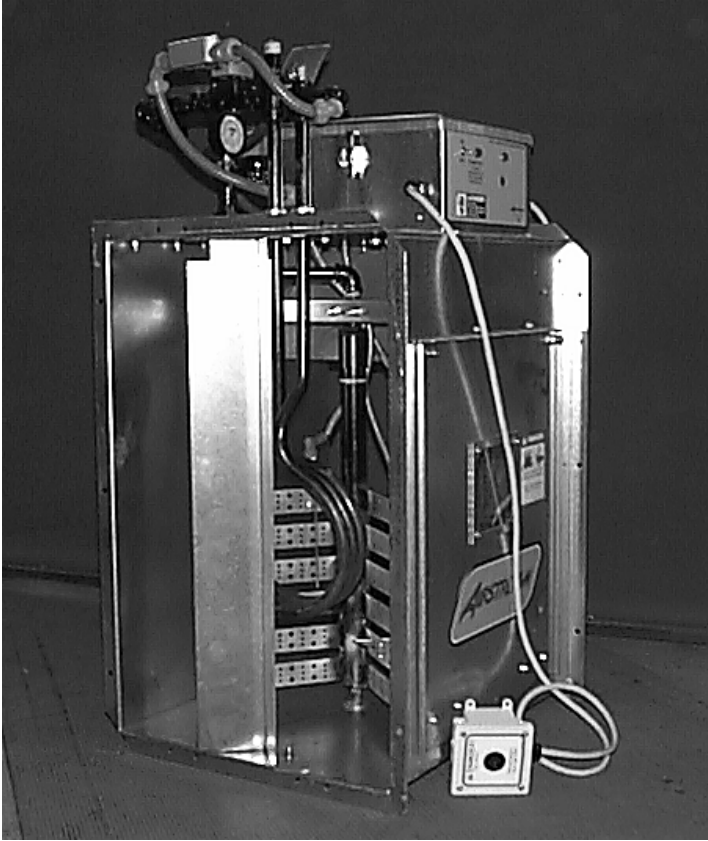

Figure C



Adjusting the vaporizer coil on a liquid propane model. The top photo shows the setting in, and the bottom photo shows the coil out.

### Adjusting The Vaporizer

1. Vaporizer should be adjusted so the vapor pipetrain runs warm to the touch (100°-120°F).
2. Loosen 5/16" bolt on adjustment bracket.
3. Swivel vaporizer away from flame if running too hot, closer to flame if too cold.
4. Move vaporizer only 1" at a time and allow a few minutes for temperature to equalize.
5. Tighten 5/16" bolt and watch heater run for several minutes to verify adjustment.

### Running The Dryer

The display will indicate "FLAME" when flame is sensed. If no flame is sensed, the "FLAME" message will be off. The display indicates what part of the cycle it is in. If the unit is a hi-lo dryer, the display will indicate whether it is in the "HI-FLAME" or "LO-FLAME" part of the cycle. (See "programming set points" page 21 for setting the hi-lo flame temperature). If the temperature is above the high temperature setting, the flame will be off, the "FLAME" message will be out and the display will be flashing "OFF-CYCLE".

If the flame is shut off because of the humidity sensor (humidistat), the display flashes "OFF-CYCLE HUMIDISTAT".

The limits are continuously checked during the drying operation. A limit switch open or any other error condition will cause the dryer to shutdown, and the fan will be shut-down. **If a limit opens, or an error condition occurs during drying, the control will lockup in the error display mode. Power must be shut off and back on to the control to clear the error condition--even if the error or limit that caused the shutdown has been corrected.** This is to keep the display locked up with the condition that caused the error, allowing the operator time to determine what caused the shutdown.

### Programming Set Points

Depressing the "PROGRAM" switch (lower left) causes the display to enter the program mode. Each item below is programmed by using the up and down arrow switches. Holding down these up and down arrow switches for about 2 seconds will cause the numbers to increase/decrease rapidly until the switch is released. When finished programming an item, depressing the "PROGRAM" switch again will cause the new setting to be entered into memory, and the display will advance to the next function to be programmed.

**Programming may be done at anytime (unless an error condition exists) even while the dryer is in operation.**

Programming a system with

Multiple heaters may be done at any heater control console. The information programmed is automatically transmitted to all other heaters when the programming is complete.

**Hi Limit Set Point**--The upper left cursor is flashing indicating the mode. If the plenum temperature increases above this point, the flame is shut off--"OFF-CYCLE" is displayed on screen.

**Cycle Set Point**--The upper 2nd from left cursor is flashing indicating the mode. **If the dryer is not a hi-lo dryer, this function is skipped.** If the plenum temperature increases above this point, the flame reduces to "LO-FLAME".

**Humidity Set Point**--The upper 2nd from right cursor is flashing indicating the mode. If the humidity is above this point the dryer operates normally--flame on and off at the high limit and cycle set points. If the humidity is below this point the dryer goes into the "OFF-CYCLE" mode.

**Temperature Differential**--The upper right cursor is flashing indicating the mode. If the flame shuts off because the temperature is greater than the high limit set point, the temperature must fall below the (Set Point minus Temperature Differential) for the flame to come back on.



Programming the high-limit set point.

On hi-lo units when the unit reaches cycle set point, the flame will switch to lo-flame and unit will not cycle back to hi-flame until (Set Point minus Temperature Differential) is reached.

Temperature differential would normally be set for 10-15 degrees F for high temp units, and 2-5 degrees F for lo-temp units.

**Humidity Differential**--The upper right cursor is flashing indicating the mode. If the flame shuts off because the humidity set point, the humidity must rise above the ( Set Point plus Humidity Differential) for the flame to come back on. (Normally set to 5%)

## Programming Hours To Shutdown

To change the hours to shutdown, depress and hold the "SHUTDOWN HOURS" switch. While holding in on the switch, depress the up and

down arrow switches to alter the hours. Setting range is 0 to 200 hours.

## Drying Grain In The Hours To Shutdown Mode

While drying grain, depress and hold the "SHUTDOWN HOURS" switch. While holding in on that switch, depress the "START" switch. After depressing the start switch one time, the heater is in the shutdown mode. Then, the fan and heater shutdown when the time expires. This is indicated by the lower left cursor flashing.

Depressing the start switch again (while holding in on the "SHUTDOWN HOURS" switch) will cause only the heater to shut off. This leaves the fan on when the time expires. This is indicated by the 2nd from lower left cursor flashing. Depressing the start switch one more time returns the heater into the continuous--non-shutdown mode.

## Run Hours Display

Run hours are recorded when the controller detects that the fan is on (airflow). The hours may be viewed by depressing the "HOURS" to get hours and "HOURS X 1000" to get the number of 1000 hours accumulated.

## Multiple Heater Notes

When multiple heaters are connected together, the temperature and humidity sensors must be connected to the master.



Setting the cycle set point.



## Modulating Valve Operation

1. The modulating valve regulates gas flow through the heater based on sensing unit in the plenum, and maintains a constant drying air temperature.
2. The sensing bulb of the modulating valve should be mounted through the bin wall with the side reading "top" up. The bulb reacts to temperature. It changes the amount of gas (increase or decrease), burning warmer or cooler depending on the position of the valve SET POINT. If the bulb is cooler than it was at the SET POINT, the bulb senses the cooler temperature and opens the valve further so more heat is applied to the drying air. If the bulb is warmer than it was at the SET POINT, the valve closes further and reduces the temperature until the air is at the valve SET POINT.
3. It is important that the pressure regulator be set high enough to allow the modulating valve to deliver enough gas to maintain the plenum temperature necessary. The regulator is normally factory set at 15 psi (propane units). To set the regulator, run the heater and turn the modulating valve T-handle in. This gets full line pressure to the burner. Then adjust regulator to read 15 psi (depending on the plenum temperature needed).
4. Turn the fan and heater on. To set the modulating valve, turn the T-handle out (counterclockwise) until loose and wait a few minutes for the plenum temperature to equalize. When the temperature under the bin has equalized, gradually turn T-handle in (clockwise) about 1/2 turn at a time.

Wait until temperature under bin has equalized as before. If temperature under bin is less than the desired temperature, continue turning T-handle in, increasing gas flow and waiting for plenum temperature to equalize until the desired temperature is the stable temperature of the plenum. If temperature under bin is the same 10 minutes after you last made any adjustments to the T-handle you can be certain that the temperature under the bin is the SET POINT of the valve. **1 turn of the T-handle equals approximately 7 degrees F of temperature.**
5. The valve will now keep the plenum temperature at the set point regardless of ambient conditions as long as humidistat or thermostat do not shut down the heater. A bypass orifice is used to maintain a small flame when outside temperature is near or above the set point of the valve. The bypass insures steady application of heat at minimum gas flow operation. Bypass orifice will only operate correctly if pressure regulator is set correctly.
6. To observe how the modulating valve increases the efficiency of bin drying, check the gas pressure of the unit in the morning and compare to the pressure read mid-afternoon. If the ambient (outside) temperature is significantly greater later in the day (as normal), the gas pressure will be less. Since less heat is required to maintain the same temperature in the plenum, the modulating valve will have reduced the amount of gas used by the heater.

**Configuration Dip Switches (Normally Done At GSI)**

These switches are used to configure the heater control for various types of heaters.

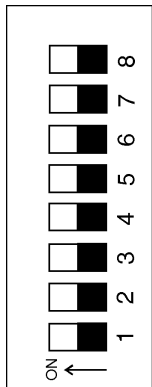

Stand alone heater with no slaves, all dip switches in the off state.

Multiple heaters connected together through the serial link.

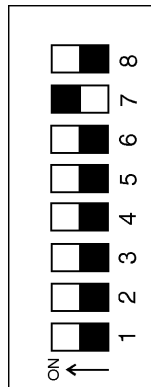

Master with one slave-dip switch 7 on/all others off.



Slave #1-dip switch one and three on/all others off.

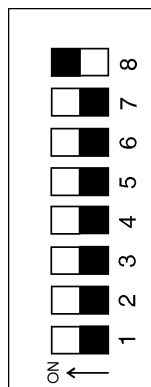

Master with two slaves-dip switch 8 on/all others off.



Slave #2-dip switch two and three on/all others off.

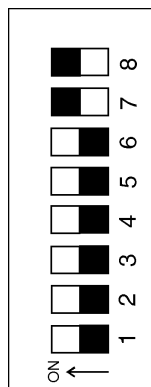

Master with 3 slaves-dip switch 7 & 8 on/all others off.



Slave #3-dip switch one, two and three on/all others off.

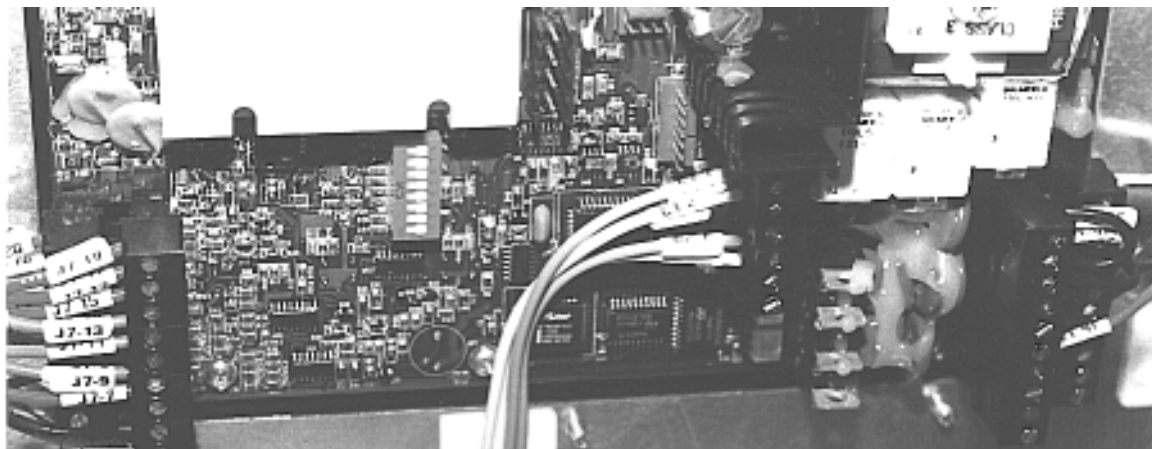

The backside of the control board, showing the dip switch placement.

**Limit Switches**

The following limit switch errors light up individually on the heaters LCD screen: PLENUM, HOUSING, VAPOR, TEMP HI LIMIT.

Note: When a shutdown does occur due to an error condition, the amount of time elapsed since the shutdown can be viewed by pressing the down arrow switch (up to 218 Hours).

**Multiple Heater Error Conditions**

If two or more heaters are connected together through the serial link, and the master cannot communicate with a slave controller, the master will display

"SLA" on the main display and the "RX" "TX" symbols will be flashing.

**If a limit switch error or one of the error numbers 1 through 8 occurs, that error is displayed on the slave where the error originates. The master displays "SLA ERROR".**

**Misc Error Numbers**

**1**

Temperature probe 1 open.

**2**

Temperature probe 1 short.

**3**

Temperature probe 2 open.

**4**

Temperature probe 2 short.

**5**

Airflow open.

**6**

Airflow short.

**7**

Illegal flame sense.  
Error 7 is most likely caused by stuck open solenoid. Error 7 will not shutdown fan until loss of flame is detected by control.

**8**

Flame probe short error.

**9**

Slave #1 inconsistent with master with either the drying grain flag or the LP main solenoid or cycle solenoid.  
Most likely the slave got re-set powering up with the solenoids off.

**10**

Slave #2 inconsistent.  
Same as error 9 for slave #1.

**11**

Slave #3 inconsistent.  
Same as error 9 for slave #1.

**12**

Wrong voltage.  
Dip switch #5 is the voltage selector switch. If dip switch #5 in "ON" that selects 240 VAC. If the unit has only 120 VAC applied, error 12 will show up. If dip switch #5 is "OFF" that selects 120 VAC. If the unit has 240 VAC applied error 12 will show up.

**13**

+11 volt DC shorted to ground.

**000**

This indicates that one of the other on screen errors (vapor, plenum or housing temp hi-limit or flame out or no airflow has occurred).

(Errors 9 through 11 are displayed only if multiple heaters are tied together through serial link).

*Note: Temperature sensor connection-the temperature sensor (bolt) must always be connected to the master.*

This is important because if the fan heater is set up at GSI for 120 VAC and the customer connects to 240 VAC the heater control will work, but if allowed to operate the solenoids will have 240 VAC applied to them which will damage solenoids.

**The heater control display showing error #7.**



All Airstream heaters are constructed of durable weather-resistant materials, so a minimum amount of service should be required; however before the unit is started for the first time each season there are a few items that need to be checked out. All damaged parts should be repaired or replaced.

1. Disconnect and lock out power to fan and heater. Open control box lid and inspect all components for moisture, vibration or rodent damage.

Inspect and tighten all loose terminal connections. Replace any damaged wiring.

2. Remove burner orifice tube and inspect for dirt or foreign material. Clean out if necessary.
3. Inspect burner for wear or foreign material in any of the ports. Clean or replace parts if necessary.
4. Inspect the spark plug and flame probe for corrosion and damage. Clean or replace if necessary.

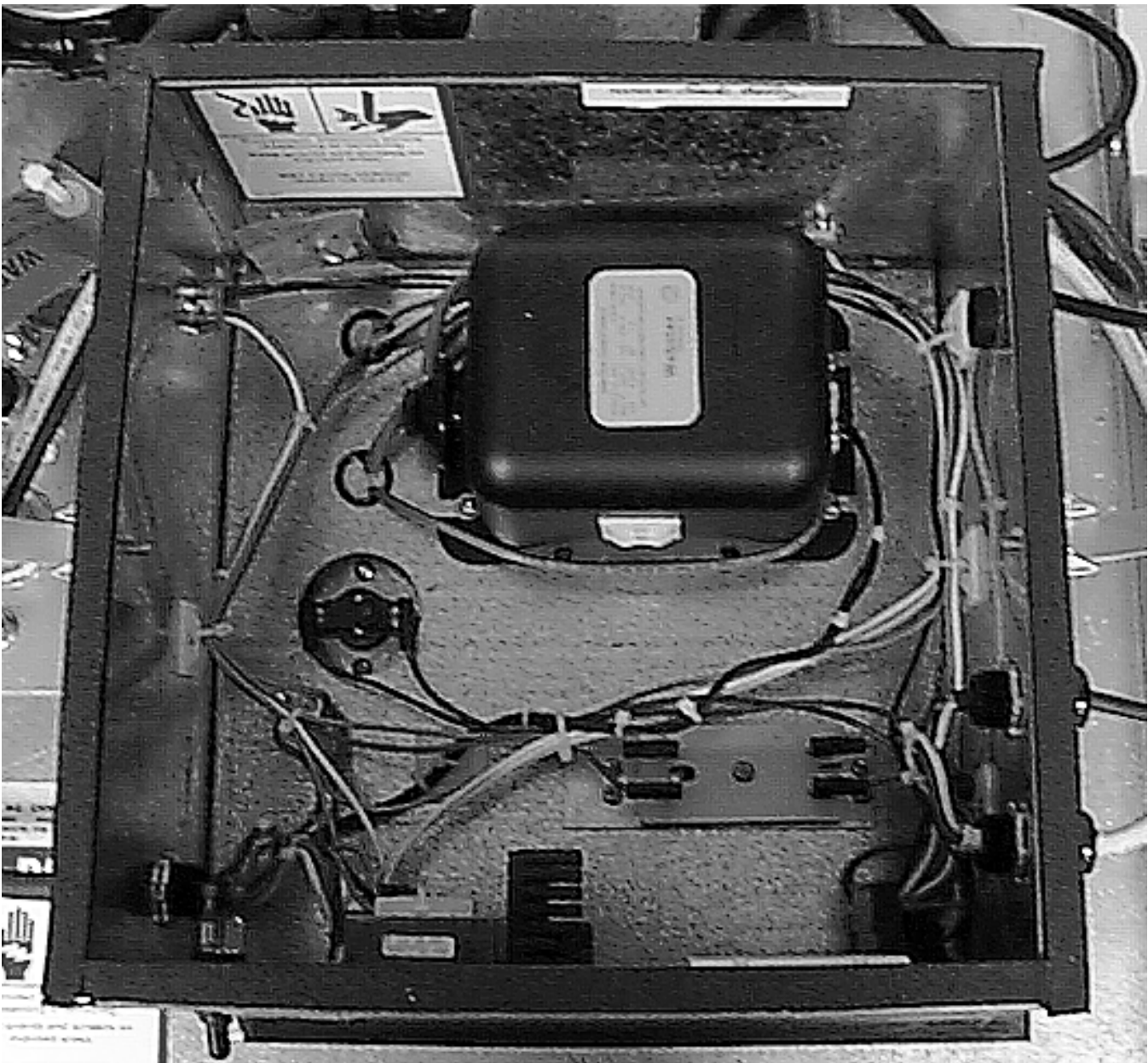

The Series 2000 control box.

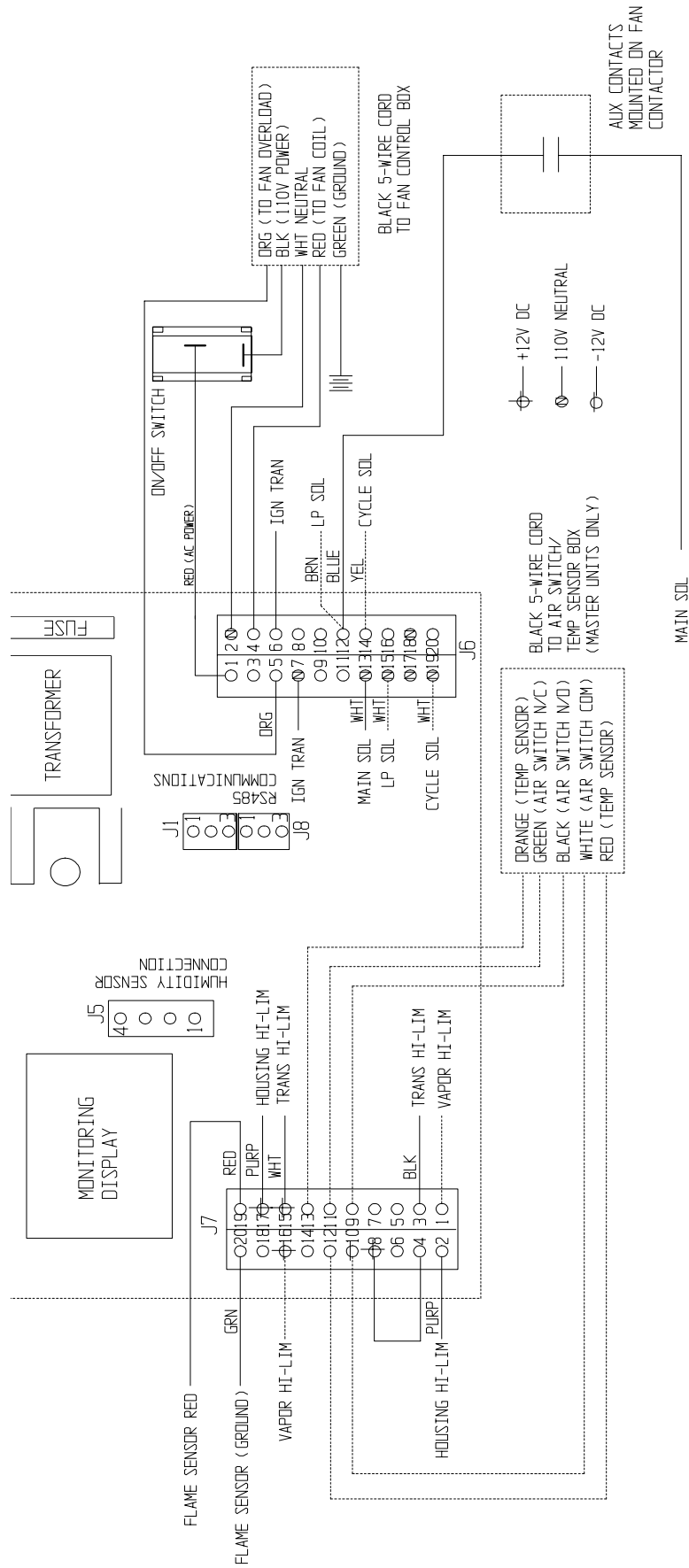

**10-15 Dw High Temp Heater Parts**

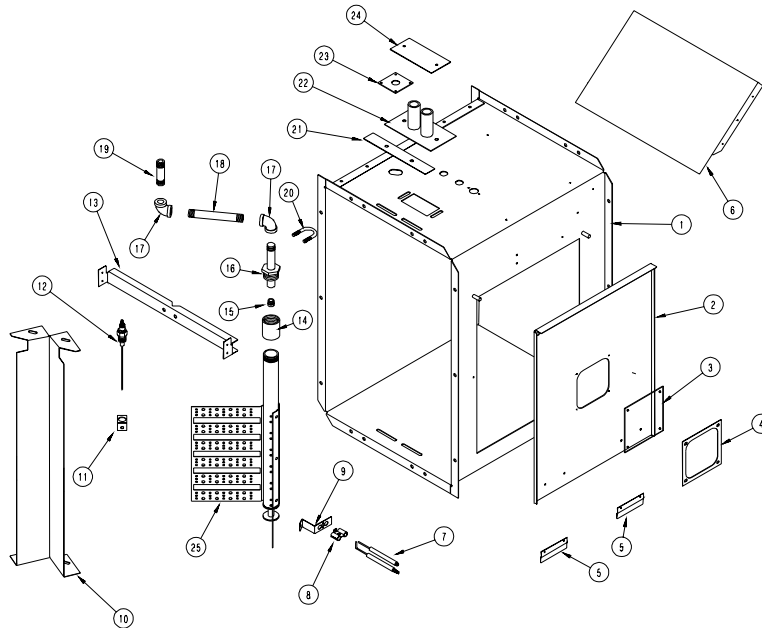

1	HF-7076	10-15 HP Housing Assembly
2	HF-7288	Access Side Cover
3	HF-7380	Plastic View Window
4	HF-7379	Access Panel Cover Plate
5	HF-7287	Access Panel Holders
6	HF-7063	10-15 Diverter Plate
7	CD-0238	Ignitor (2 Required)
8	HF-7201	Ignitor Clamp Half (2 Required)
9	HF-7204	Ignitor Bracket
10	HF-7101	10-15 Diverter Angle
11	CD-0187	Flame Sensor Bracket (Deluxe, Sr 2000)
12	*THH-4179	Flame Sensor (Deluxe, Sr 2000)
13	HF-7290	10-15 Burner Brace
14	HH-7035	1 1/4" Coupling
15	HF-7083	1/4" Orifice (Propane)
15	HF-7034	3/8" Orifice (Natural Gas)
16	HF-7027	Orifice Tube Weldment
17	THH-4071	1/2" Elbow
18	HH-3854	1/2" x 6" Nipple
19	HH-3670	1/2" x 2.1/2" Nipple
20	S-7259	5/16" U-Bolt
21	HF-7079	Diverter Angle Cover
22	HF-7020	Vaporizer Support Weldment
23	HF-7297	Burner Support Plate
24	HF-7032	Vapor Cover Plate
25	HF-7023	HI-Fire Burner Assembly
NS	HF-7261	10-40HP Spark Plug Wire
NS	HF-7263	10-40HP Flame Probe Wire

**10-15 Dw Low Temp Heater Parts**

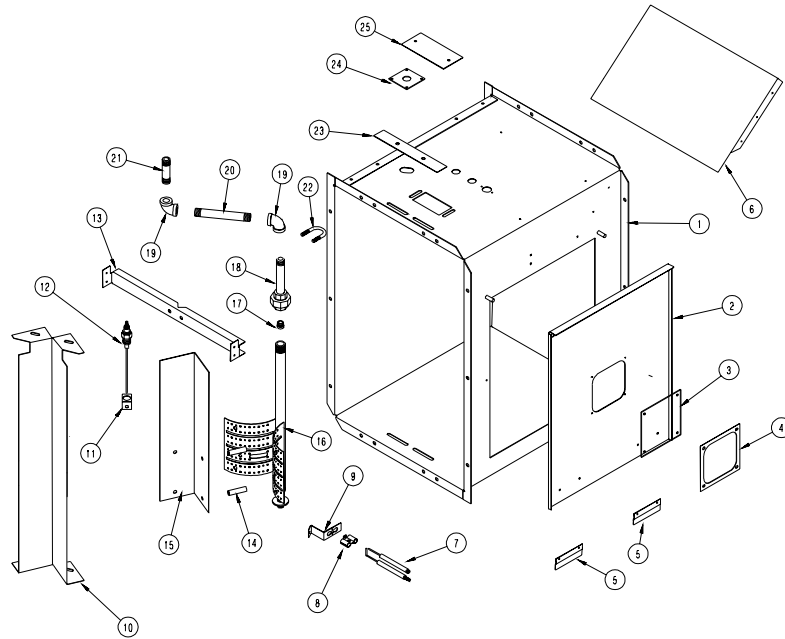

1	HF-7076	10-15 HP Housing Assembly
2	HF-7288	Access Side Cover
3	HF-7380	Plastic View Window
4	HF-7379	Access Panel Cover Plate
5	HF-7287	Access Panel Holders
6	HF-7063	10-15 Diverter Plate
7	CD-0238	Ignitor (2 Required)
8	HF-7201	Ignitor Clamp Half (2 Required)
9	HF-7204	Ignitor Bracket
10	HF-7101	10-15 Diverter Angle
11	CD-0187	Flame Sensor Bracket (Deluxe, Sr 2000)
12	*THH-4179	Flame Sensor (Deluxe, Sr 2000)
13	HF-7290	10-15 Burner Brace
14	HF-7072	LO-Fire Diverter Spacer
15	HF-7071	LO-Fire Diverter
16	HF-7070	LO-Fire Burner Assembly
17	HF-7035	7/64" Orifice (Propane)
17	HF-7036	5/32" Orifice (Natural Gas)
18	HF-7069	LO-fire Orifice Weldment
19	THH-4071	1/2" Elbow
20	HH-3854	1/2" x 6" Nipple
21	HH-3670	1/2" x 2.1/2" Nipple
22	S-7259	5/16" U-Bolt
23	HF-7079	Diverter Angle Cover
24	HF-7297	Burner Support Plate
25	HF-7032	Vapor Cover Plate
NS	HF-7261	10-40HP Spark Plug Wire
NS	HF-7263	10-40HP Flame Probe Wire

## 20-30 Dw High Temp Heater Parts

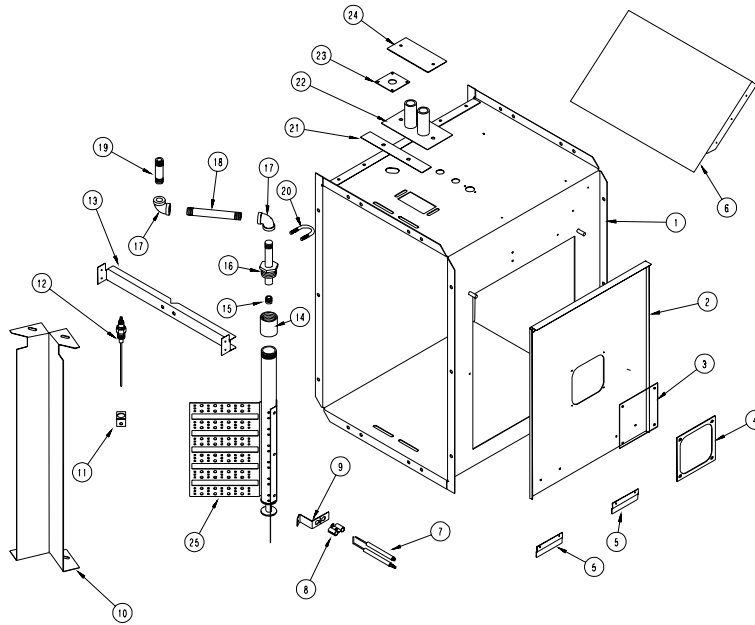

1	HF-7077	20-30 HP Housing Assembly
2	HF-7288	Access Side Cover
3	HF-7380	Plastic View Window
4	HF-7379	Access Panel Cover Plate
5	HF-7287	Access Panel Holders
6	HF-7064	20-30 Diverter Plate
7	CD-0238	Ignitor (2 Required)
8	HF-7201	Ignitor Clamp Half (2 Required)
9	HF-7204	Ignitor Bracket
10	HF-7102	20-30 Diverter Angle
11	CD-0187	Flame Sensor Bracket (Deluxe, Sr 2000)
12	*THH-4179	Flame Sensor (Deluxe, Sr 2000)
13	HF-7300	20-30 Burner Brace
14	HH-7035	1 1/4" Coupling
15	HF-7083	1/4" Orifice (Propane)
15	HF-7034	3/8" Orifice (Natural Gas)
16	HF-7027	Orifice Tube Weldment
17	THH-4071	1/2" Elbow
18	HH-3854	1/2" x 6" Nipple
19	HH-3670	1/2" x 2.1/2" Nipple
20	S-7259	5/16" U-Bolt
21	HF-7079	Diverter Angle Cover
22	HF-7020	Vaporizer Support Weldment
23	HF-7297	Burner Support Plate
24	HF-7032	Vapor Cover Plate
25	HF-7023	HI-Fire Burner Assembly
NS	HF-7261	10-40HP Spark Plug Wire
NS	HF-7263	10-40HP Flame Probe Wire



**20-30 Dw Low Temp Heater Parts**

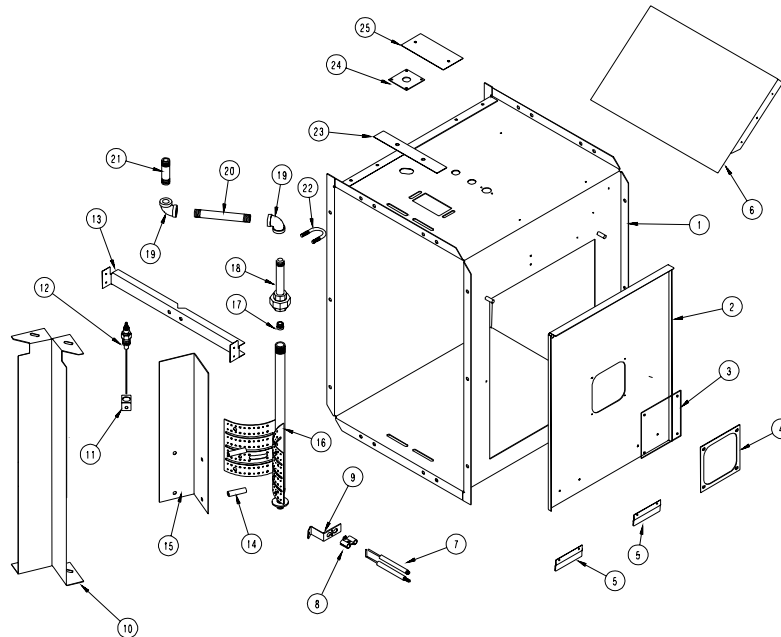

1	HF-7077	20-30 HP Housing Assembly
2	HF-7288	Access Side Cover
3	HH-2020	Plastic View Window
4	HF-6914	Access Cover Plate
5	HF-7287	Access Panel Holders
6	HF-7064	20-30 Diverter Plate
7	CD-0238	Ignitor (2 Required)
8	HF-7201	Ignitor Clamp Half (2 Required)
9	HF-7204	Ignitor Bracket
10	HF-7102	20-30 Diverter Angle
11	CD-0187	Flame Sensor Bracket (Deluxe, Sr 2000)
12	*THH-4179	Flame Sensor (Deluxe, Sr 2000)
13	HF-7300	20-30 Burner Brace
14	HF-7072	LO-Fire Diverter Spacer
15	HF-7071	LO-Fire Diverter
16	HF-7070	LO-Fire Burner Assembly
17	HF-7035	7/64" Orifice (Propane)
17	HF-7036	5/32" Orifice (Natural Gas)
18	HF-7069	LO-fire Orifice Weldment
19	THH-4071	1/2" Elbow
20	HH-3854	1/2" x 6" Nipple
21	HH-3670	1/2" x 2.1/2" Nipple
22	S-7259	5/16" U-Bolt
23	HF-7079	Diverter Angle Cover
24	HF-7297	Burner Support Plate
25	HF-7032	Vapor Cover Plate
NS	HF-7261	10-40HP Spark Plug Wire
NS	HF-7263	10-40HP Flame Probe Wire

### 40hp Dw High Temp Heater Parts

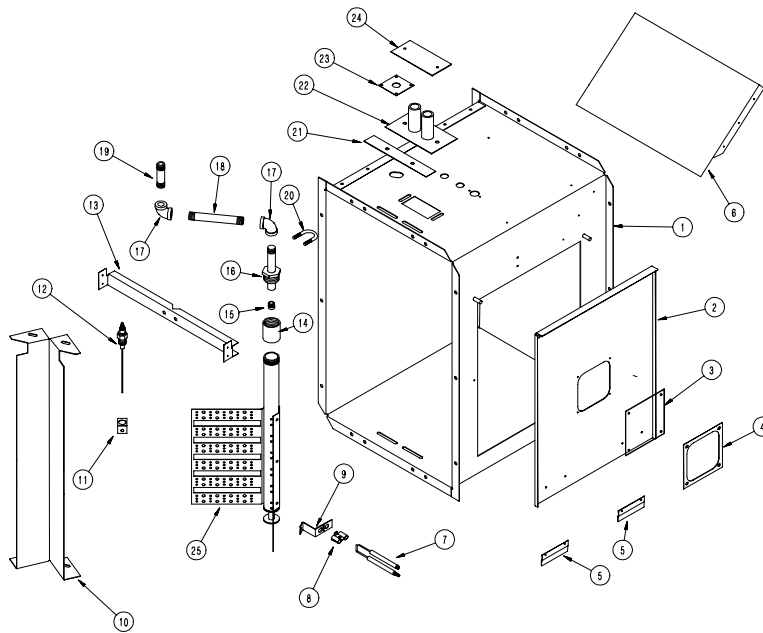

1	HF-7472	40 HP Housing Assembly
2	HF-7288	Access Side Cover
3	HF-7380	Plastic View Window
4	HF-7379	Access Panel Cover Plate
5	HF-7287	Access Panel Holders
6	HF-7140	40 HP Diverter Plate
7	CD-0238	Ignitor (2 Required)
8	HF-7201	Ignitor Clamp Half (2 Required)
9	HF-7204	Ignitor Bracket
10	HF-7102	20-40 Diverter Angle
11	CD-0187	Flame Sensor Bracket (Deluxe, Sr 2000)
12	*THH-4179	Flame Sensor (Deluxe, Sr 2000)
13	HF-7304	40 Burner Brace
14	HH-7035	1 1/4" Coupling
15	HF-7083	1/4" Orifice (Propane)
15	HF-7034	3/8" Orifice (Natural Gas)
16	HF-7027	Orifice Tube Weldment
17	THH-4071	1/2" Elbow
18	HH-3854	1/2" x 6" Nipple
19	HH-3670	1/2" x 2.1/2" Nipple
20	S-7259	5/16" U-Bolt
21	HF-7079	Diverter Angle Cover
22	HF-7020	Vaporizer Support Weldment
23	HF-7297	Burner Support Plate
24	HF-7032	Vapor Cover Plate
25	HF-7023	HI-Fire Burner Assembly
NS	HF-7261	10-40HP Spark Plug Wire
NS	HF-7263	10-40HP Flame Probe Wire

**40hp Dw Low Temp Heater Parts**

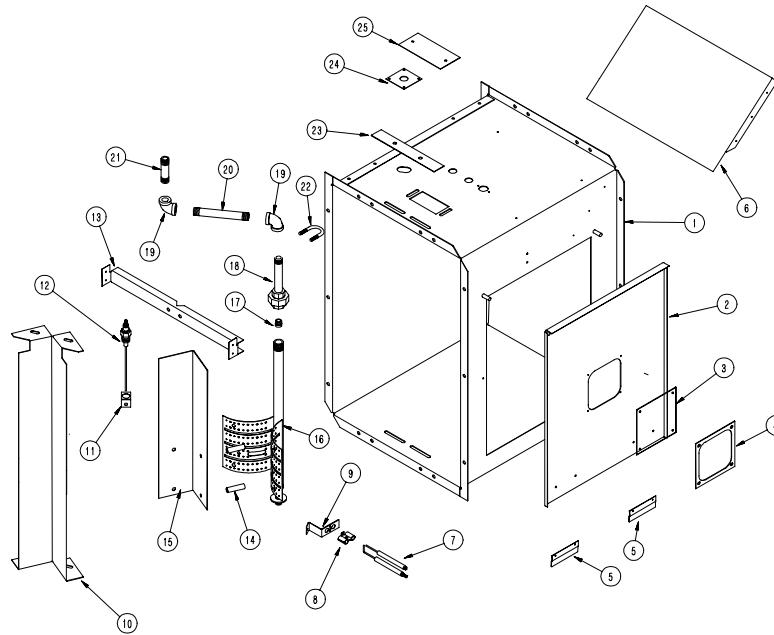

1	HF-7472	40 HP Housing Assembly
2	HF-7288	Access Side Cover
3	HH-2020	Plastic View Window
4	HF-6914	Access Cover Plate
5	HF-7287	Access Panel Holders
6	HF-7140	40 Diverter Plate
7	CD-0238	Ignitor (2 Required)
8	HF-7201	Ignitor Clamp Half (2 Required)
9	HF-7204	Ignitor Bracket
10	HF-7102	20-40 Diverter Angle
11	CD-0187	Flame Sensor Bracket (Deluxe, Sr 2000)
12	*THH-4179	Flame Sensor (Deluxe, Sr 2000)
13	HF-7304	40 Burner Brace
14	HF-7072	LO-Fire Diverter Spacer
15	HF-7071	LO-Fire Diverter
16	HF-7070	LO-Fire Burner Assembly
17	HF-7035	7/64" Orifice (Propane)
17	HF-7036	5/32" Orifice (Natural Gas)
18	HF-7069	LO-fire Orifice Weldment
19	THH-4071	1/2" Elbow
20	HH-3854	1/2" x 6" Nipple
21	HH-3670	1/2" x 2.1/2" Nipple
22	S-7259	5/16" U-Bolt
23	HF-7079	Diverter Angle Cover
24	HF-7297	Burner Support Plate
25	HF-7032	Vapor Cover Plate
NS	HF-7261	10-40HP Spark Plug Wire
NS	HF-7263	10-40HP Flame Probe Wire

### Series 2000 DW Gas Heater Control Box Parts

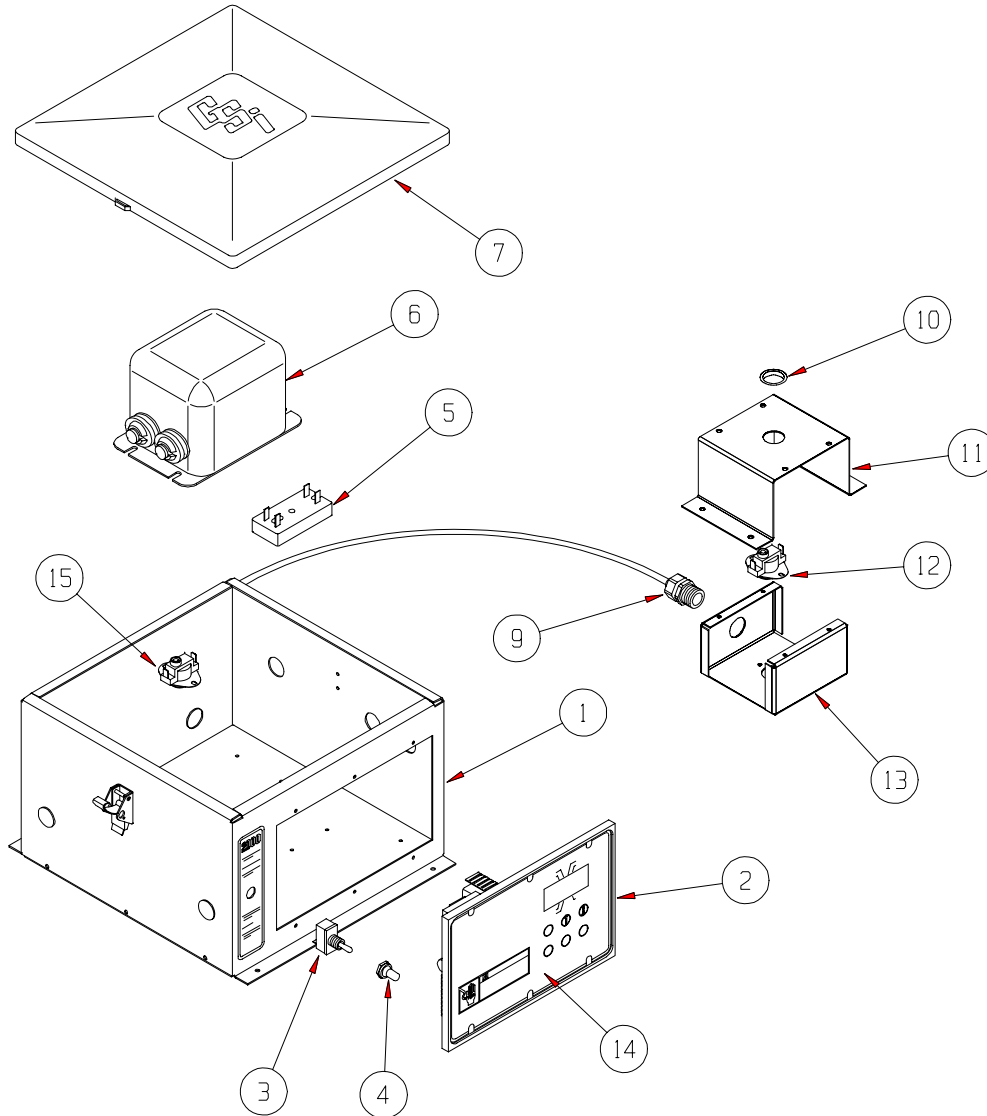

Key	Part Number	Description
1	HF-7316	Control Box Housing (Series 2000)
2	*HF-7276RH	*Series 2000 rebuilt board assembly (w/decal)
2	HF-7276H	Series 2000 board assembly (w/decal)
3	HH-1442	Toggle Switch
4	HF-7277	Switch Boot
5	HF-7255	Ballast Resistor
6	HH-1093	Transformer 2 pole
7	F-942	Control Box Lid
8	HH-1092	High Limit Switch 180 Degree
9	FH-1310	Cord Connector
10	HF-7414	Recessed Plastic Plug
11	HF-7454	High Limit Switch Box Top
12	HF-7439	High Limit Switch 250 Degree
13	HF-7455	High Limit Switch Box Bottom
14	DC-821	Front Panel Decal

Air Switch Temperature Sensor Box

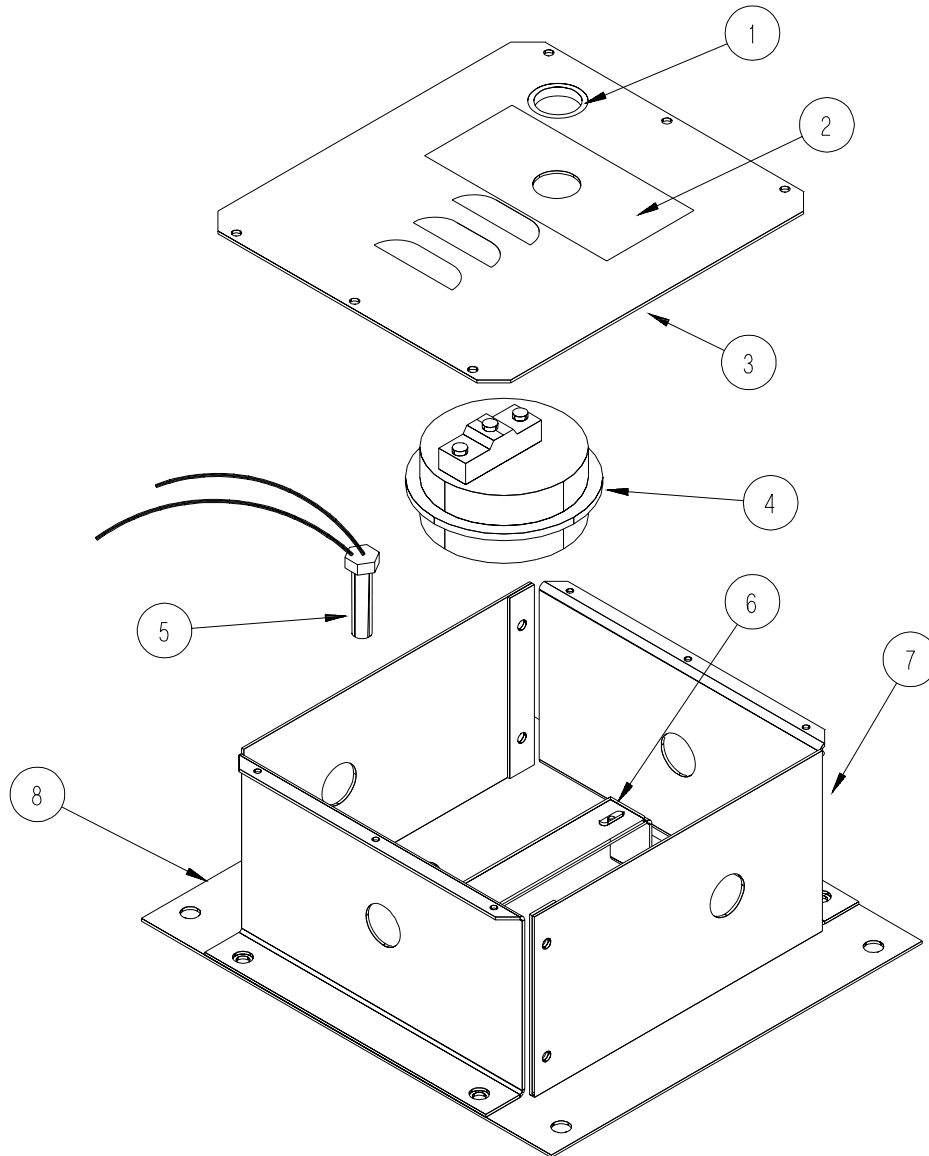

Key	Part Number	Description
1	HF-7414	Recessed Plastic Plug
2	DC-1103	Adjustment Decal
3	HF-7461	Box Lid
4	HH-7063	Air Pressure Switch
5	HF-7236	Thermistor Temp Sensor
6	HF-7460	Switch Mounting Bracket
7	HF-7458	Box Half (Requires 2)
8	HF-7459	Bin Mounting Plate
NS	D03-0322	Filter
NS	HF-7462	Air Switch Assembly w/ Temp Sensor
NS	HF-7471	Air Switch Assembly w/o Temp Sensor

### Dw Propane Vapor Pipetrain Parts

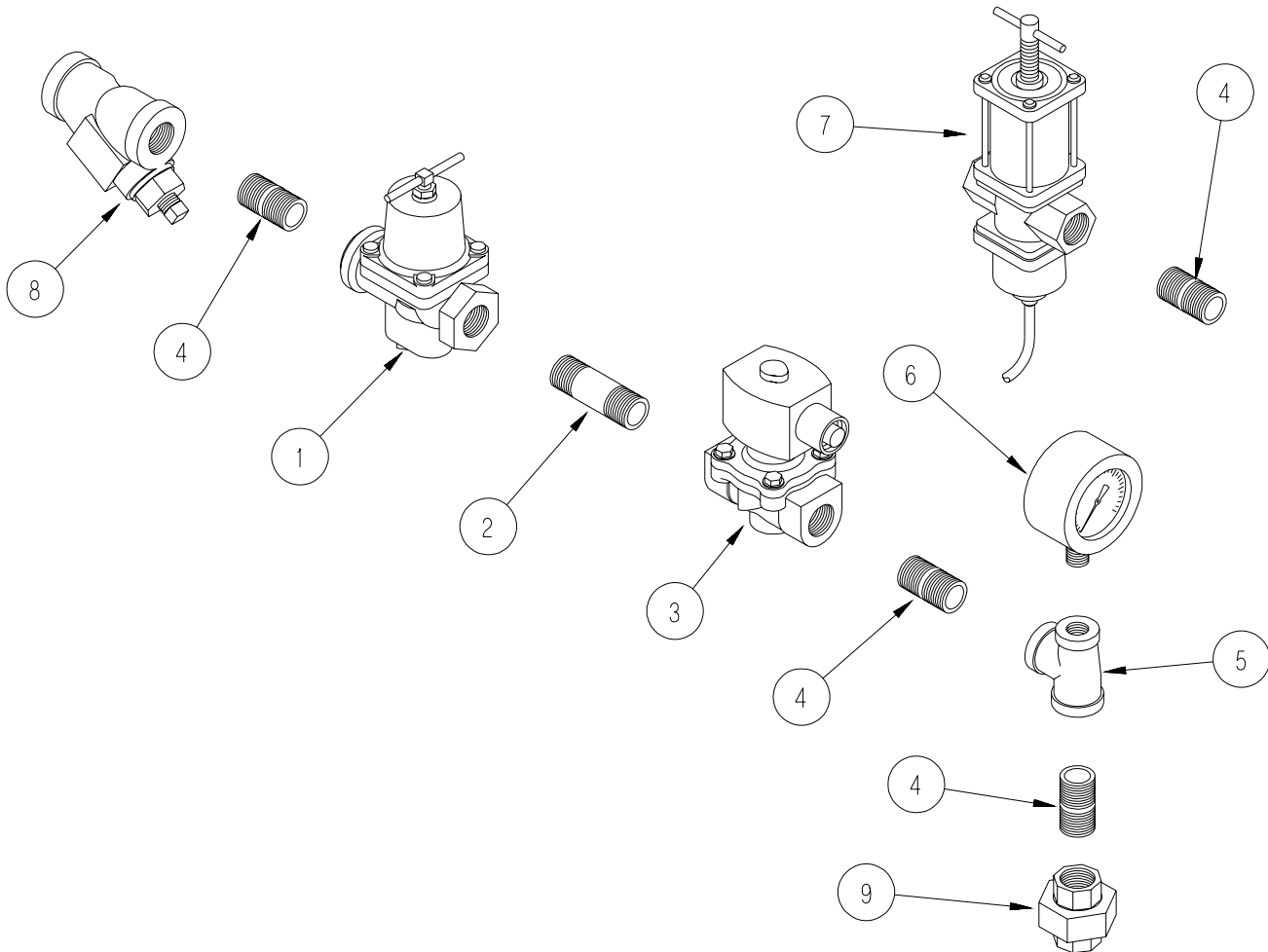

1	TFC-0023	1/2" 0-30 PSI Regulator (Deluxe, Sr 2000)
2	HH-3670	1/2" x 2 1/2" Nipple
3	TFC-0032	1/2" Solenoid (Deluxe, Sr. 2000)
4	HH-2029	1/2" x 1 1/2" Nipple
5	S-3853	1/2" x 1/4" x 1/2" Tee
6	HH-2984	30 PSI gauge
7	HH-2653	Modulating Valve
8	HH-1251	1/2" Strainer
9	HH-2028	1/2" Female Union

**Dw Natural Gas Vapor Pipetrain Parts**

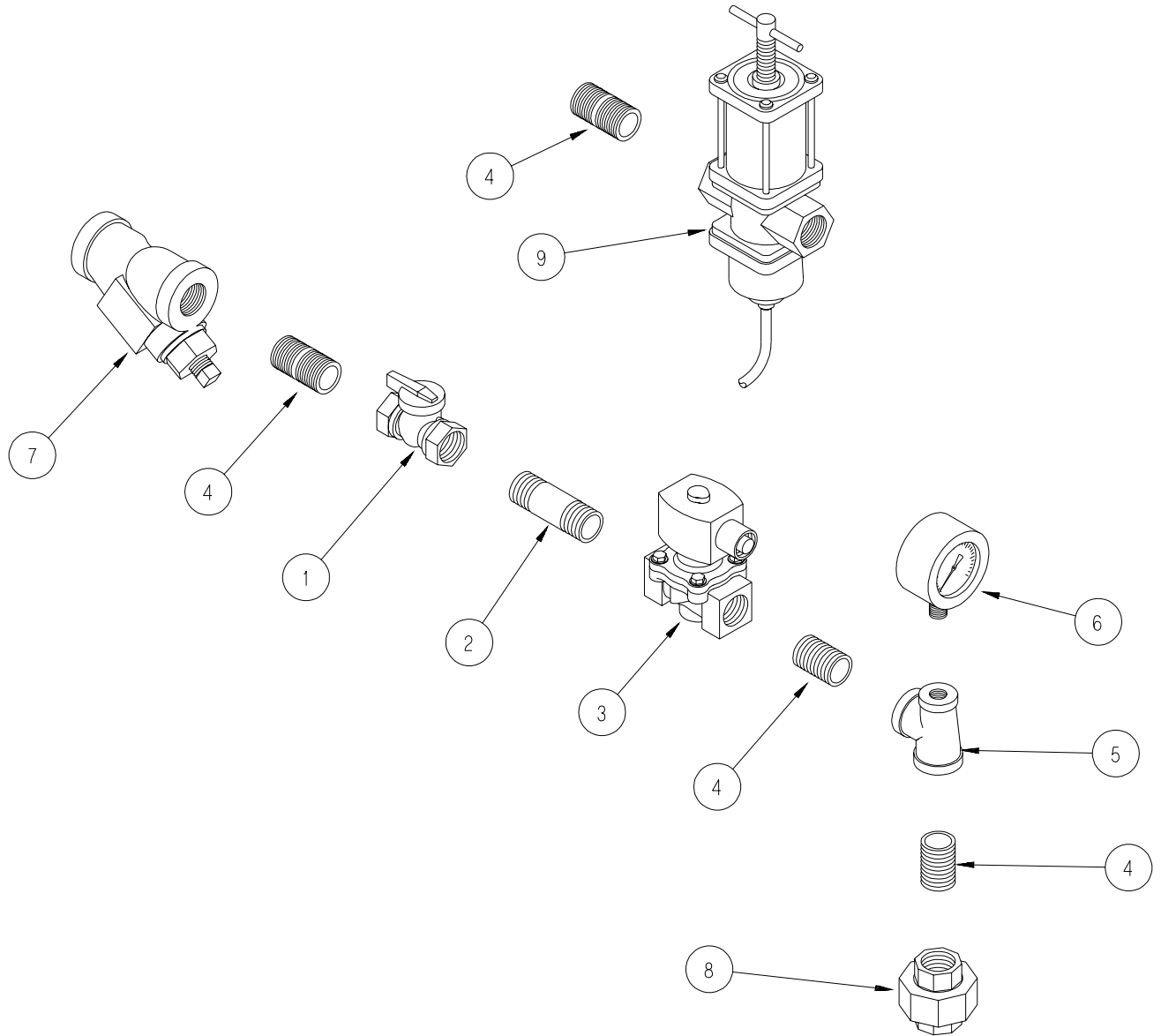

1	TFC-0051	3/4" Ball Valve
2	THH-4136	3/4" x 3" Nipple
3	TFC-0081	3/4" Solenoid (Deluxe, Sr 2000)
4	THH-4121	3/4" Close Nipple
5	THH-4158	3/4" x 1/4" x 3/4" Tee
6	D08-0022	15 PSI Gauge
7	D67-0008	3/4" Strainer
8	HF-7230	3/4" Female Union
9	HH-7064	3/4" Modulating Valve (Optional)

### Dw Propane Vapor Hi-lo Pipetrain Parts

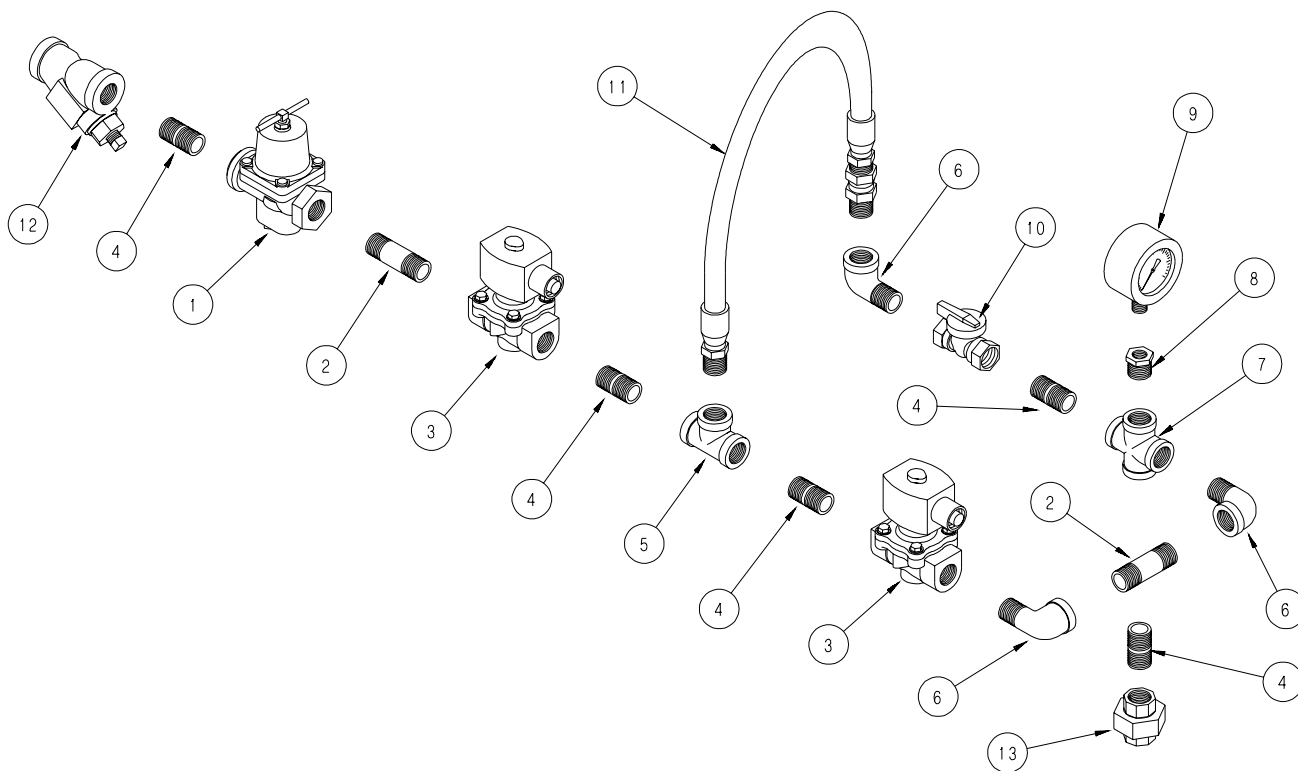

1	TFC-0023	1/2" 0-30 PSI Regulator (Deluxe, Sr 2000)
2	HH-3670	1/2" x 2 1/2" Nipple
3	TFC-0032	1/2" Solenoid (Deluxe, Sr 2000)
4	HH-2029	1/2" x 1 1/2" Nipple
5	HH-1453	1/2" x 1/2" x 1/2" Tee
6	THH-4067	1/2" Street Elbow
7	THH-4127	1/2" Cross
8	THH-4032	1/2" x 1/4" Reducer Bushing
9	HH-2984	30 PSI gauge
10	TFC-0030	1/2" Ball Valve
11	HH-7019	1/2" Gas Hose
12	HH-1251	1/2" Strainer
13	HH-2028	1/2" Female Union



**Dw Natural Gas Hi-lo Pipetrain Parts**

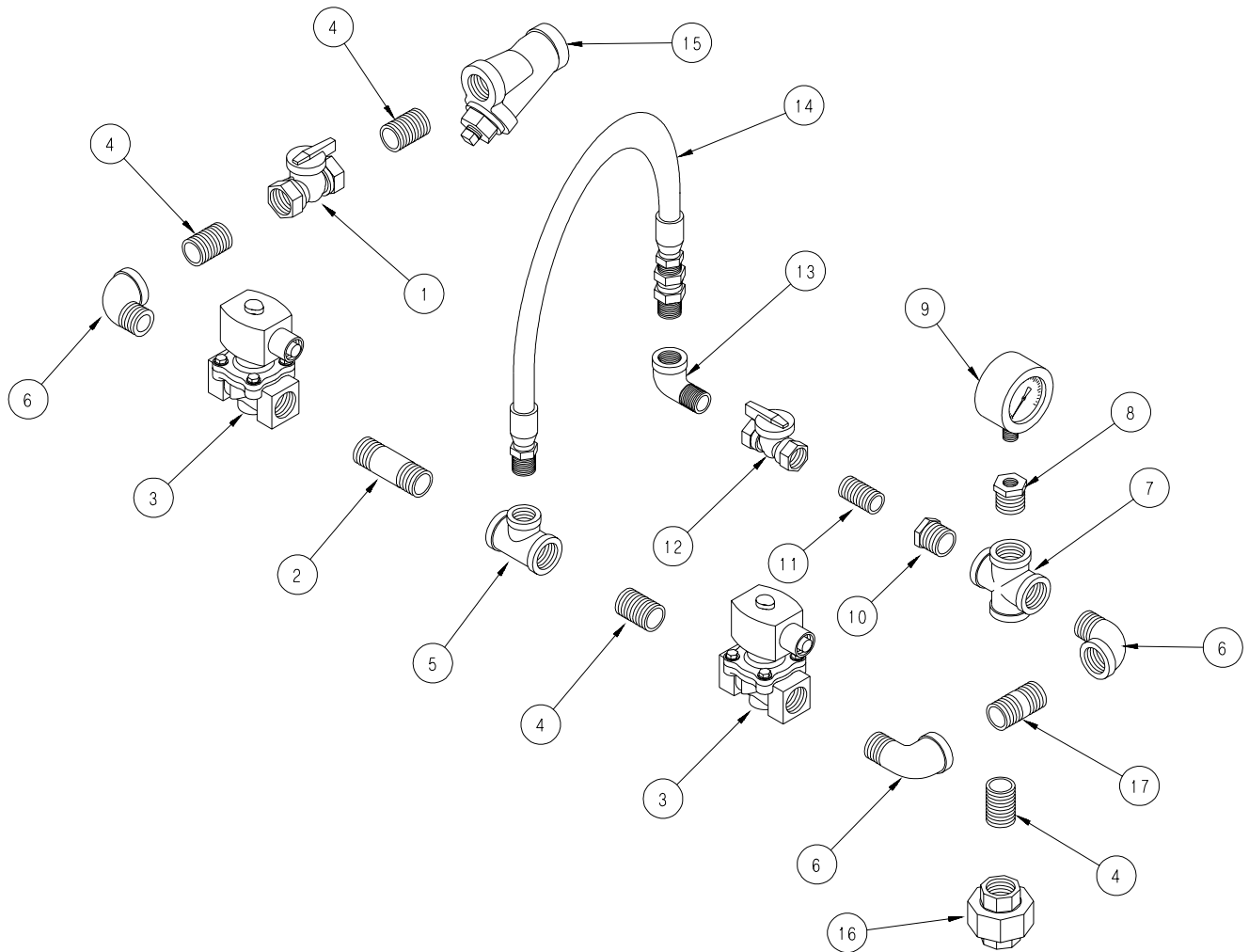

1	TFC-0051	3/4" Ball Valve
2	THH-4136	3/4" x 3" Nipple
3	TFC-0081	3/4" Solenoid (Deluxe, Sr 2000)
4	THH-4121	3/4" Close Nipple
5	THH-4174	3/4" x 3/4" x 1/2" Tee
6	THH-4066	3/4" Street Elbow
7	THH-4068	3/4" Cross
8	THH-4042	3/4" x 1/4" Reducer Bushing
9	D08-0022	15 PSI Gauge
10	D07-0028	3/4" x 1/2" Reducer Bushing
11	HH-2029	1/2" x 1 1/2" Nipple
12	TFC-0030	1/2" Ball Valve
13	THH-4067	1/2" Street Elbow
14	HH-7019	1/2" Gas Hose
15	D67-0008	3/4" Strainer
16	HF-7230	3/4" Female Union
17	THH-4125	3/4" x 2" Nipple

### Dw Lp Pipetrain Parts

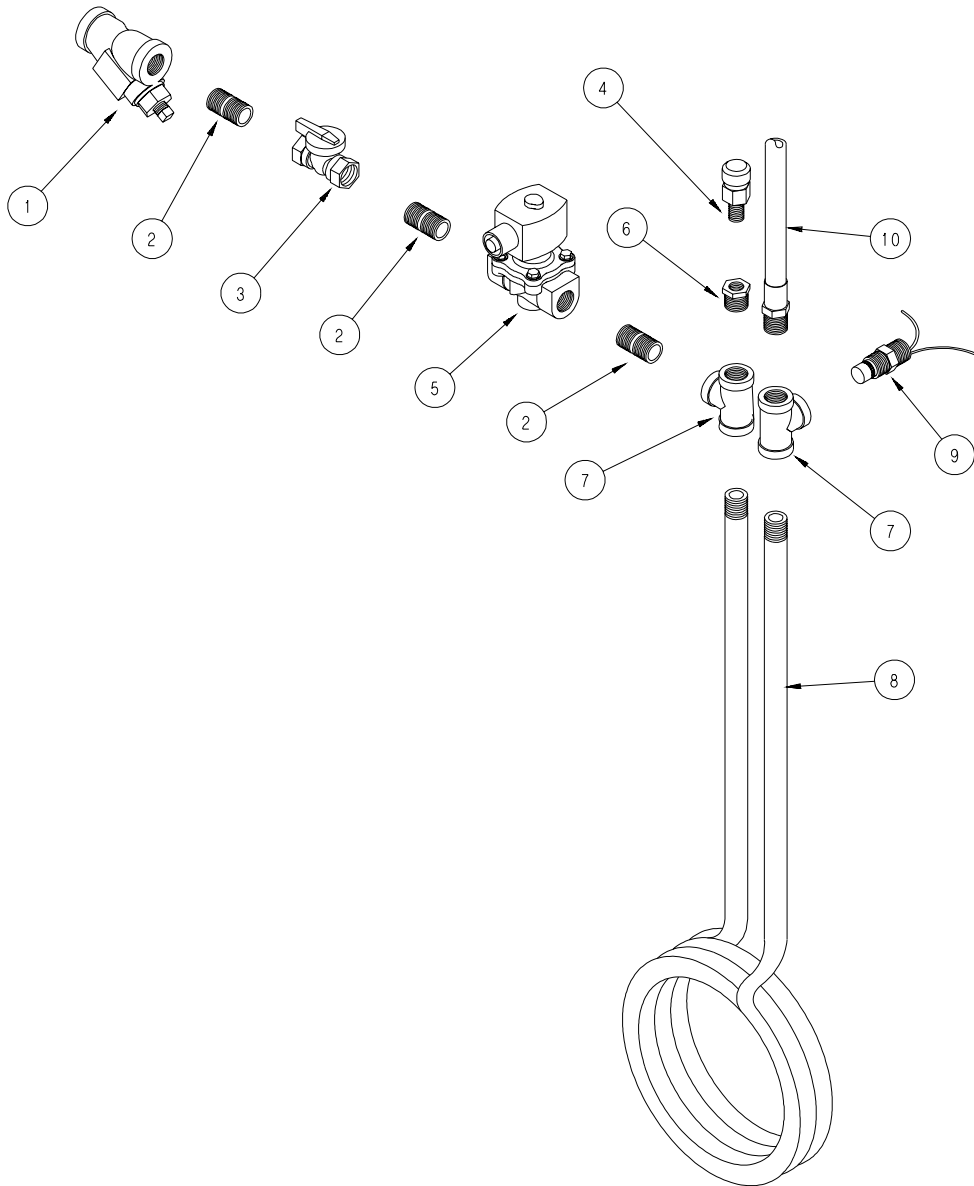

1	HH-1251	1/2" Strainer
2	D07-0019	1/2" x 1 1/2" Nipple Sh. 80
3	TFC-0030	1/2" Ball Valve
4	HH-4845	1/4" Relief Valve
5	TFC-0092	1/2" Solenoid Valve 300 PSI
6	THH-4023	1/2" x 1/4" Reducer Bushing
7	THH-4058	1/2" x 1/2" x 1/2" Tee Sh. 80
8	CD-0197	Vaporizer Coil
9	HH-7013	200 Degree Vapor High Limit
10	D07-0009	5/16" x 24" LP Gas Hose



THE GSI GROUP, INC. ("GSI") WARRANTS ALL PRODUCTS MANUFACTURED BY GSI TO BE FREE OF DEFECTS IN MATERIAL AND WORKMANSHIP UNDER NORMAL USAGE AND CONDITIONS FOR A PERIOD OF 36 MONTHS AFTER RETAIL SALE TO THE ORIGINAL END USER OF SUCH PRODUCTS. GSI'S ONLY OBLIGATION IS, AND PURCHASER'S SOLE REMEDY SHALL BE FOR GSI, TO REPAIR OR REPLACE, AT GSI'S OPTION AND EXPENSE, PRODUCTS THAT, IN GSI'S SOLE JUDGMENT, CONTAIN A MATERIAL DEFECT DUE TO MATERIALS OR WORKMANSHIP. ALL DELIVERY AND SHIPMENT CHARGES TO AND FROM GSI'S FACTORY WILL BE PURCHASER'S RESPONSIBILITY. EXPENSES INCURRED BY OR ON BEHALF OF THE PURCHASER WITHOUT PRIOR WRITTEN AUTHORIZATION FROM AN AUTHORIZED EMPLOYEE OF GSI SHALL BE THE SOLE RESPONSIBILITY OF THE PURCHASER.

EXCEPT FOR THE ABOVE STATED EXPRESS LIMITED WARRANTIES, GSI MAKES NO WARRANTY OF ANY KIND, EXPRESSED OR IMPLIED, INCLUDING, WITHOUT LIMITATION, WARRANTIES OF MERCHANTABILITY OR FITNESS FOR A PARTICULAR PURPOSE OR USE IN CONNECTION WITH (i) PRODUCT MANUFACTURED OR SOLD BY GSI OR (ii) ANY ADVICE, INSTRUCTION, RECOMMENDATION OR SUGGESTION PROVIDED BY AN AGENT, REPRESENTATIVE OR EMPLOYEE OF GSI REGARDING OR RELATED TO THE CONFIGURATION, INSTALLATION, LAYOUT, SUITABILITY FOR A PARTICULAR PURPOSE, OR DESIGN OF SUCH PRODUCT OR PRODUCTS.

IN NO EVENT SHALL GSI BE LIABLE FOR ANY DIRECT, INDIRECT, INCIDENTAL OR CONSEQUENTIAL DAMAGES, INCLUDING, WITHOUT LIMITATION, LOSS OF ANTICIPATED PROFITS OR BENEFITS. PURCHASER'S SOLE AND EXCLUSIVE REMEDY SHALL BE LIMITED TO THAT STATED ABOVE, WHICH SHALL NOT EXCEED THE AMOUNT PAID FOR THE PRODUCT PURCHASED. THIS WARRANTY IS NOT TRANSFERABLE AND APPLIES ONLY TO THE ORIGINAL PURCHASER. GSI SHALL HAVE NO OBLIGATION OR RESPONSIBILITY FOR ANY REPRESENTATIVE OR WARRANTIES MADE BY OR ON BEHALF OF ANY DEALER, AGENT OR DISTRIBUTOR OF GSI.

GSI ASSUMES NO RESPONSIBILITY FOR FIELD MODIFICATIONS OR ERECTION DEFECTS WHICH CREATE STRUCTURAL OR STORAGE QUALITY PROBLEMS. MODIFICATIONS TO THE PRODUCT NOT SPECIFICALLY COVERED BY THE CONTENTS OF THIS MANUAL WILL NULLIFY ANY PRODUCT WARRANTY THAT MIGHT HAVE BEEN OTHERWISE AVAILABLE.

THE FOREGOING WARRANTY SHALL NOT COVER PRODUCTS OR PARTS WHICH HAVE BEEN DAMAGED BY NEGLIGENT USE, MISUSE, ALTERATION OR ACCIDENT. THIS WARRANTY COVERS ONLY PRODUCTS MANUFACTURED BY GSI. THIS WARRANTY IS EXCLUSIVE AND IN LIEU OF ALL OTHER WARRANTIES EXPRESS OR IMPLIED. GSI RESERVES THE RIGHT TO MAKE DESIGN OR SPECIFICATION CHANGES AT ANY TIME.

PRIOR TO INSTALLATION, PURCHASER HAS THE RESPONSIBILITY TO RESEARCH AND COMPLY WITH ALL FEDERAL, STATE AND LOCAL CODES WHICH MAY APPLY TO THE LOCATION AND INSTALLATION.



a division of  

---

THE GSI GROUP

---



1004 E. Illinois St.  
Assumption, IL 62510  
Phone 217-226-4421  
Fax 217-226-4498

August 1999