



This transition is designed to attach to a 55-1/4" x 12-1/4" air entrance opening in the grain bin sidewall below the perforated floor. The transition is fabricated from galvanized material and will be shipped "knocked down" for field assembly. Ample caulking is provided for complete weather-proof construction.

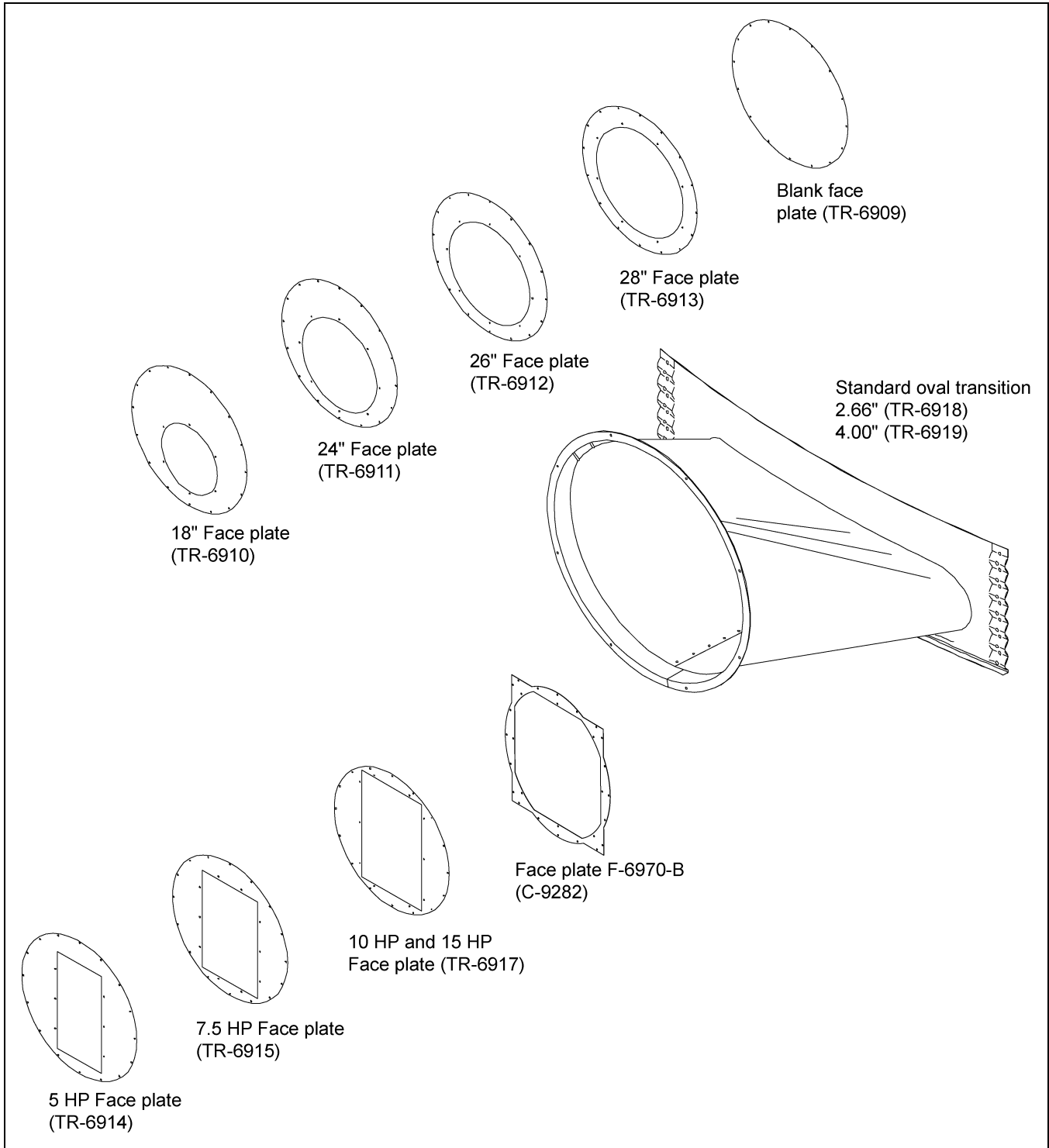

Figure 1 Transition Face Plate Assembly



Standard Oval Transition Assembly

Pad Location

IMPORTANT: Fan pad/fan must be level for proper operation. Vibration problems can result from improper fan leveling.

NOTE: Please note new fan pad location. All fan pads should start 32" from the bin wall. If heater is to be used or possibly used in the future, it is recommended that a full fan/heater pad is poured.

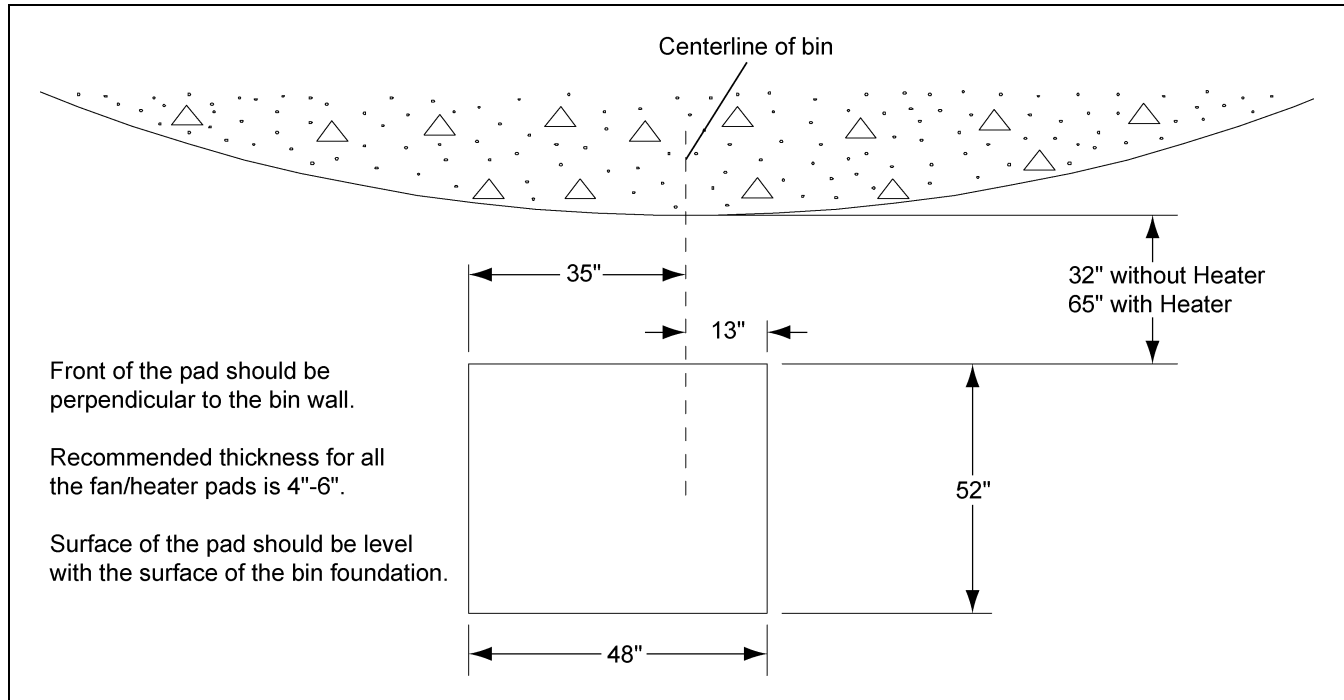

Figure 2 Centrifugal Pad Location

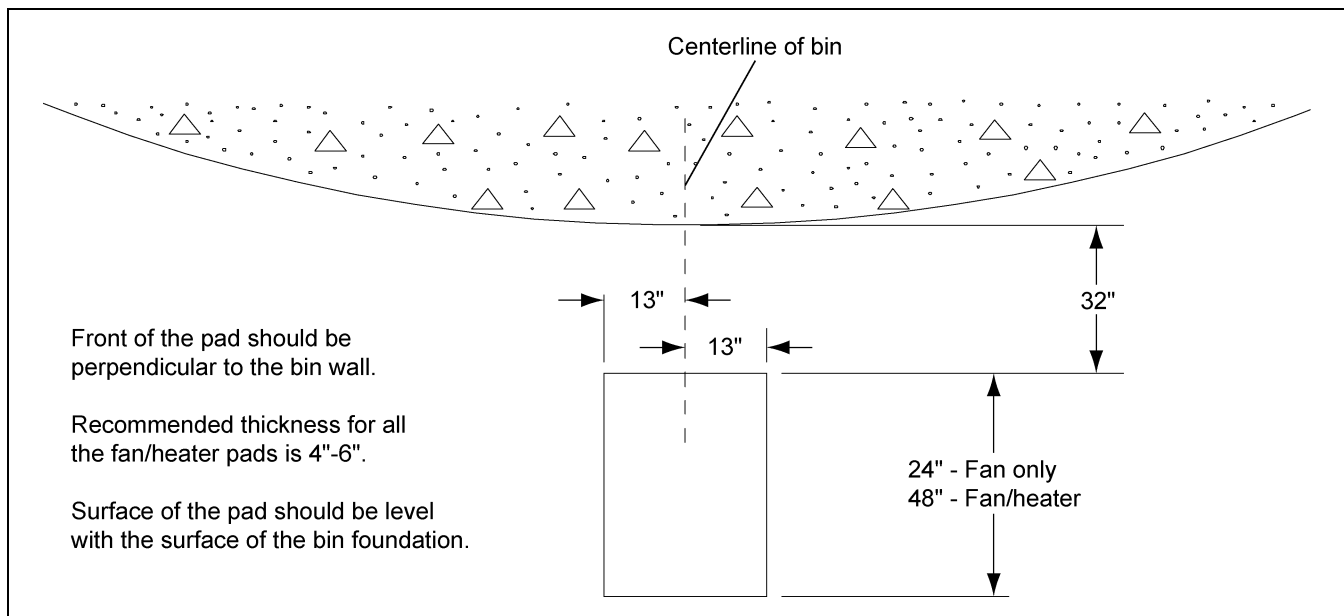

Figure 3 Vane Axial Pad Location

Transition Instructions

1. Fold and lap opposite ends of housing wrapper. Using 1/4"-20 x 1/2" bolts, bolt the seams together leaving the end two (2) holes open.
2. Rotate housing wrapper until bolted seam is on bottom. Slip housing through entrance collar until front edge is flush with extruded lip.

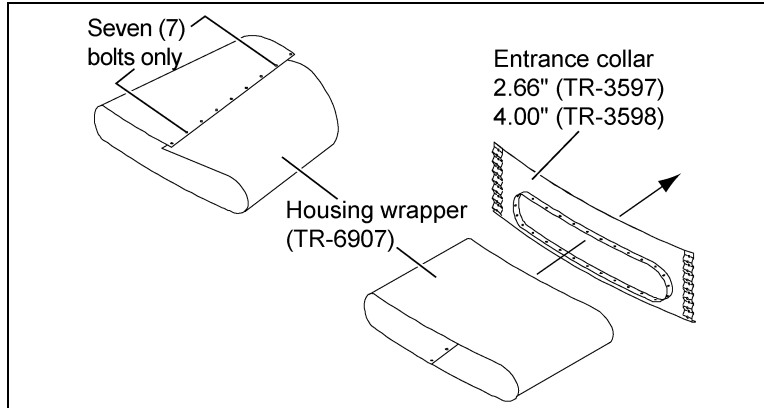

Figure 4

3. Align holes designated "A" and bolt them first. Place center brace into position and bolt top and bottom. Complete by bolting remaining holes and inserting remaining braces as shown in [Figure 5](#).

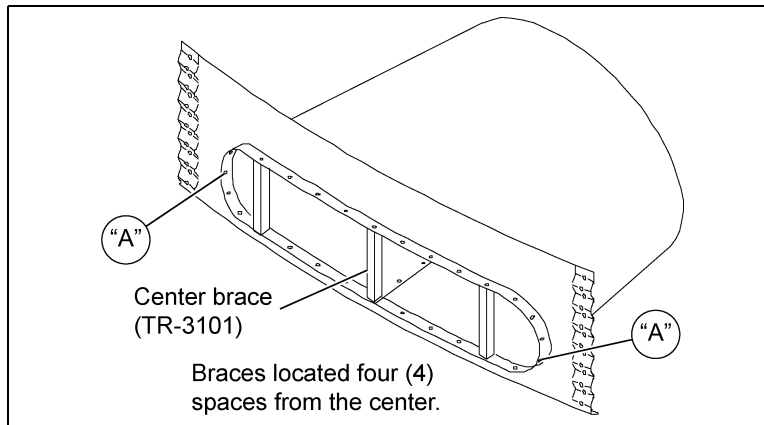

Figure 5

4. Slide transition face collar into opening, with crimped surface at top. Secure with remaining bolts.

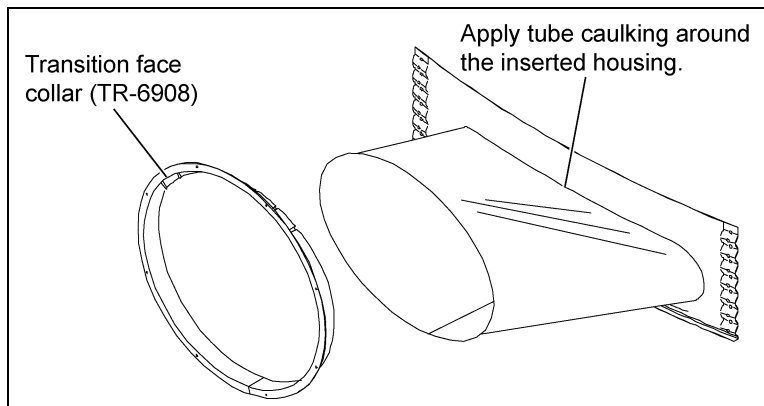

Figure 6

Standard Oval Transition Assembly

Transition Instructions (Continued)

5. Cut 55-1/4" x 12-1/4" hole through base sheet as shown in *Figure 7*. Use stiffener angle as a template and field drill three (3) 3/8" diameter holes per stiffener angle as shown in *Figure 7*. Use 5/16" x 3/4" bin bolts to attach stiffener angles to the sidewall.
6. Apply a generous bead of caulk around perimeter of opening. Using self-drilling screws attach transition housing assembly as shown in *Figure 7*.

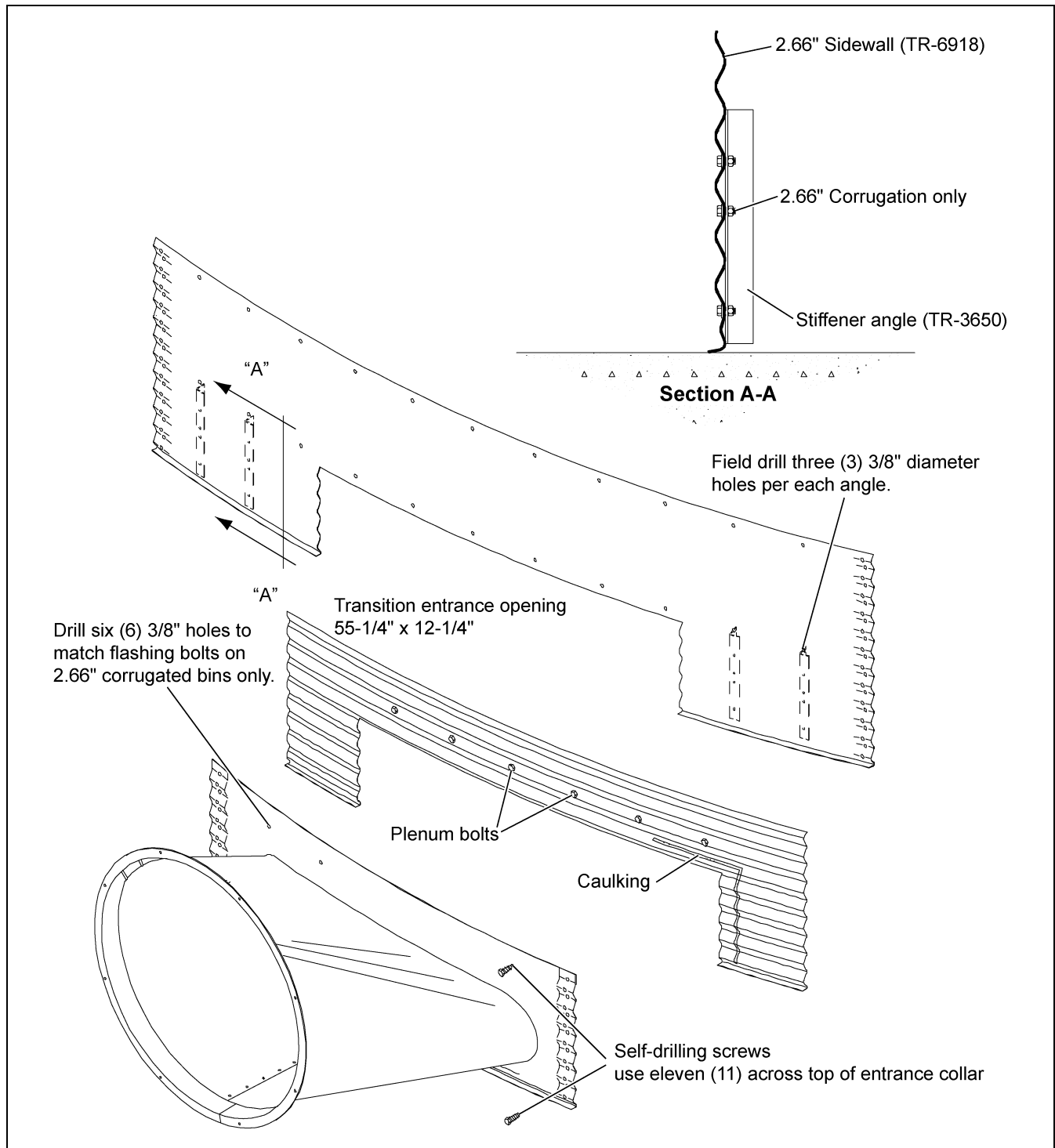

Figure 7