



Introduction

This kit is for the replacement of the mercury tilt switch with a Solid State Electronic Tilt Switch on the Red Giant Stir-Ator. This switch consists of an electronic controller (power supply and microprocessor) in a separate enclosure assembly and an accelerometer assembly.

On the Red Giant Stir-Ator, the electronic controller will be installed on to top surface of the outboard end pivot yoke. The accelerometer assembly will be installed in the tilt switch bracket in place of the mercury tilt switch. It can be manually adjusted by repositioning the bracket to adjust down auger trail-back in the same manner as the mercury switch. The Solid State Electronic Tilt Switch is powered by 230 volt and directly controls the 230 volt 1 phase power to the track drive motor.

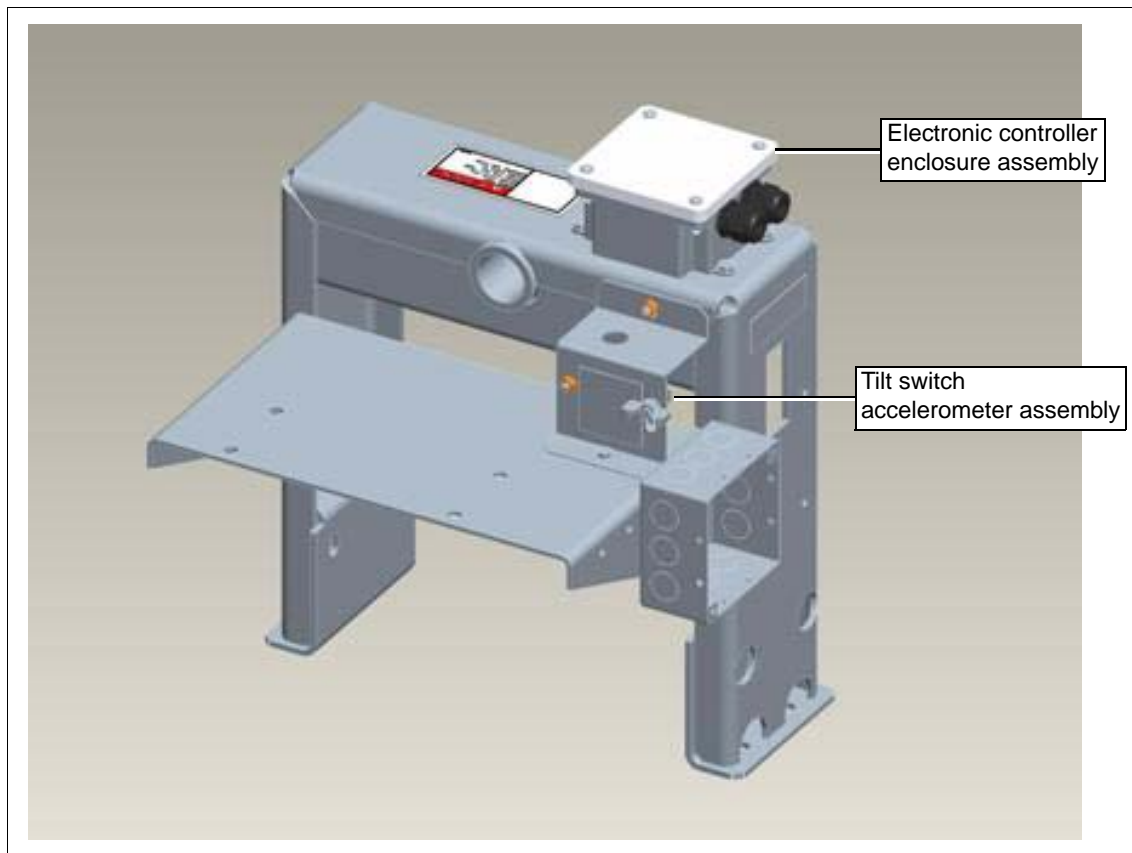

Figure 1



Solid State Electronic Tilt Switch for the Red Giant Stir-Ator

The service kit part number is:

104N2092 - For Red Giant 230 volt 1 or 3 phase, 460 volt 3 phase, 575 volt 3 phase, and 380 volt 3 phase units.

The tilt switch electronic controller printed circuit board and the accelerometer assembly will be available for service as service kit part #106E110. These components will only be supplied as a matched set.

The 460 volt, 575 volt, and 380 volt units will require the transformer for the track drive power to be rewired to place the Solid State Electronic Tilt Switch on the 230 volt side of the transformer. These changes are necessary to provide 230 volt power for the Solid State Electronic Tilt Switch and allow the tilt switch to power the track drive motor.

Installation Instructions

1. Disconnect the electrical power to the Red Giant Stir-Ator at the shut off switch box mounted to the inside of the bin roof near the roof manhole opening.



Hazard of electrical shock or burn. Always disconnect the power before attempting to perform any service function. Follow lock out/tag out procedures as outlined in O.S.H.A. section 1910.147 where appropriate.



Electrical controls and wiring should be installed by a qualified electrician.

2. Layout and drill four (4) 9/32" diameter holes in the top surface of the outboard end pivot yoke (right hand side near the tilt switch mounting bracket) to mount the electronic controller enclosure assembly. Use the dimensions shown in [Figure 2](#) or use the controller enclosure assembly as a template.

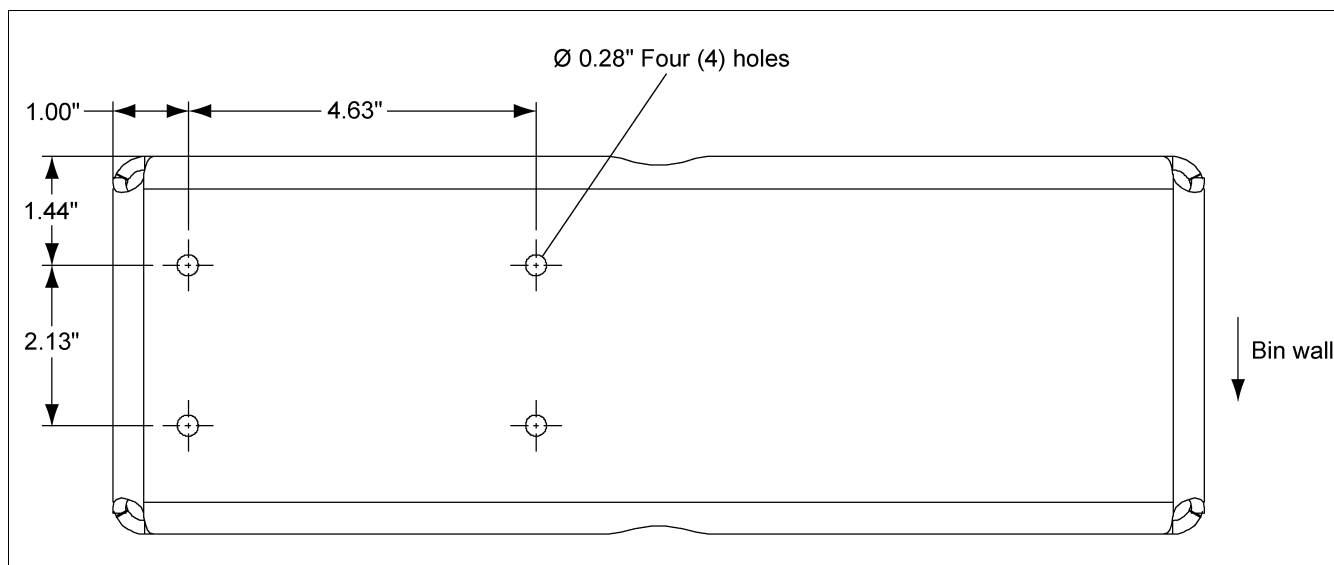

Figure 2 Drilled Hole Layout

Installation Instructions (Continued)

3. Disconnect and remove the mercury tilt switch. Install the electronic controller enclosure assembly onto the top of the outboard end pivot yoke with the two (2) cable connectors pointed toward to the right using three (3) 1/4"-20 UNC flange bolts and three (3) 1/4"-20 UNC flange nuts. Install the tilt switch accelerometer assembly into the tilt switch mounting bracket in place of the mercury tilt switch and route the accelerometer assembly electrical cord so that it will not be damaged. Install the accelerometer assembly with the arrow on the side of the accelerometer aligned with their respective directions **SWEEP** (meaning direction of travel) and **EARTH**. (See Figure 3.)



Figure 3 Accelerometer Assembly Installation

4. Wire the electronic controller according the voltage of the Red Giant Stir-Ator being retrofit. Refer to [Step 5](#) for 230 volt 1 phase and 3 phase. Refer to [Step 6 on Page 4](#) for 460 volt 3 phase or 575 volt 3 phase. Refer to [Wiring Diagrams on Pages 6-10](#) for the particular voltage for additional information.
5. Wiring for 230 volt 1 phase and 3 phase units:
 - a. Disconnect the track drive power cord from the fuse holders.
 - b. Install two (2) cable connectors, part #1EL0425, into the bin wall side of the fuse holder electrical box. Install one of these in place of the grommet through which the mercury tilt switch lead wires previously passed.
 - c. Using the cable connectors just installed, route two (2) of wire (18/3), part #106E101, from the fuse holder box to the electronic controller enclosure assembly.
 - d. Connect the black and white wires of one of the 18/3 wires to the black and white wires from the track drive power cord. (**NOTE: The green wire in this 18/3 wire will not be used.**) Leave the green wire of the track drive power cord connected to the track drive motor cord. Route the other end of this 18/3 wire through the right hand inner (bin center side) cable connector on the electronic controller enclosure assembly and connect the black and white wires to the power connector (4 terminal) on left hand side of the printed circuit board. Connect the black wire to the innermost (farthest from bin wall) terminal and connect the white wire to the inside terminal next to the black wire. (See [Figure 4 on Page 4.](#)) **NOTE: The top portion of the 4 terminal power connector pulls OFF for access.**

Installation Instructions (Continued)

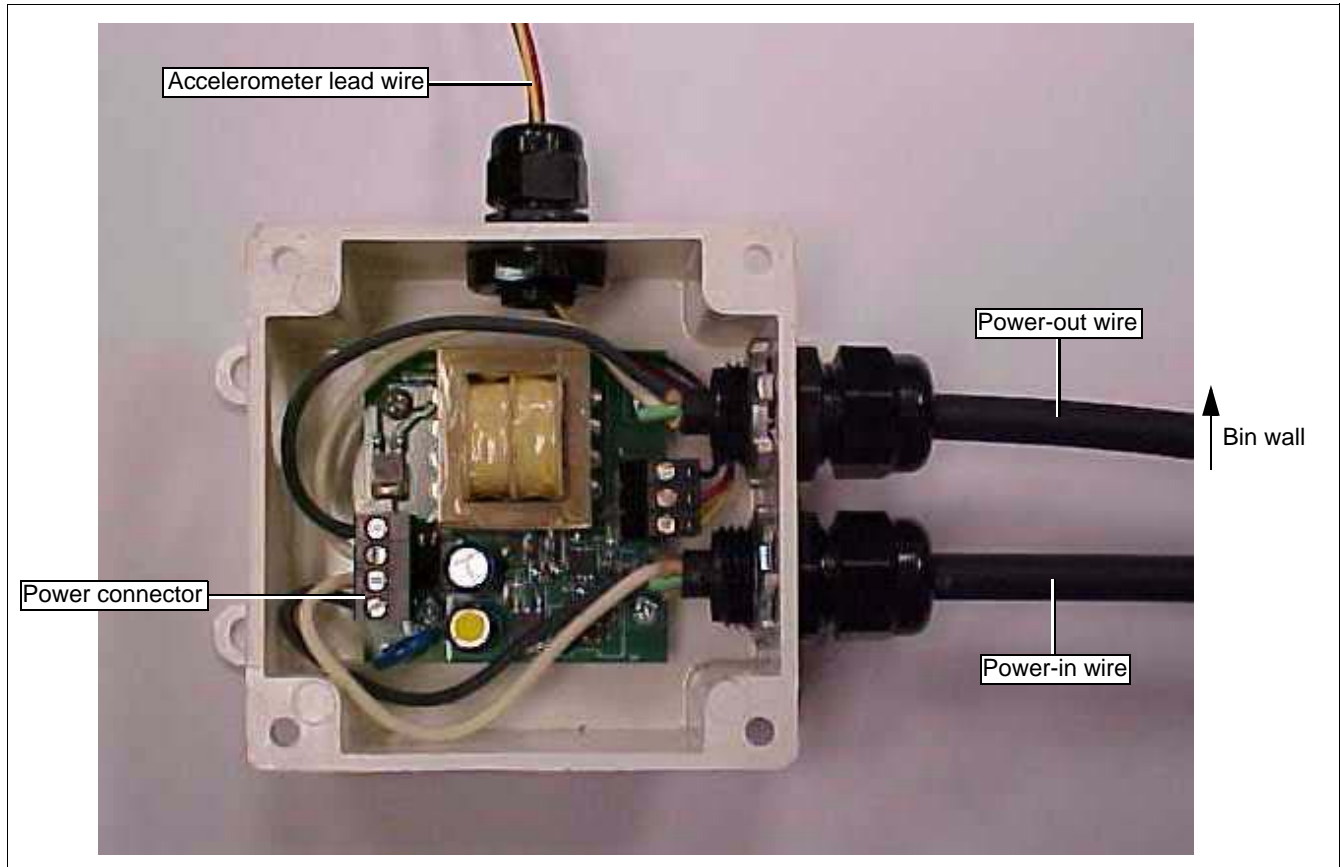

Figure 4 Electronic Controller Enclosure Assembly Power Wire Routing

- e. Connect the other 18/3 wire to the fuse holders input lead wires. (Where the track drive power cord and mercury tilt switch wires were previously connected.) Route the other end of this 18/3 wire through the right hand outer (bin center side) cable connector on the electronic controller enclosure assembly and connect the black and white wires to the power connector (4 terminal) on left hand side of the printed circuit board. Connect the black wire to the outermost (nearest bin wall) terminal and connect the white wire to the inside terminal next to the black wire. *(See Figure 4.)* **NOTE:** Both white wires of the power-in and power-out 18/3 wires should be side by side.
6. Wiring for 460 volt 3 phase, 575 volt 3 phase, and 380 volt 3 phase:
 - a. The 460 volt 3 phase, 575 volt 3 phase, and 380 volt 3 phase units all include a transformer to step the voltage down to 230 volt for the track drive motor. On these units, the Solid State Electronic Tilt Switch must be wired on the 230 volt output side of the transformer. If the transformer on the unit being retrofit is not wired with the mercury tilt switch on the 230 volt output side of the transformer, it must be rewired. Route the track drive power cord directly to the transformer. Wire the transformer according to the appropriate [Wiring Diagrams on Pages 6-10](#) for the unit primary voltage. Route the 230 volt output power cord from the transformer back to the fuse holder box. The Solid State Electronic Tilt Switch can now be installed and wired according to the [Step 5 on Page 3](#) for 230 volt units. The two (2) cable connectors, part #1EL0425, should be installed into the top of the fuse holder electrical box. The grommet through which the mercury tilt switch lead wires previously passed will not be used and should be plugged.

Installation Instructions (Continued)

7. Adjustment procedure

- a. Once installed the Solid State Electronic Tilt Switch can be adjusted to adjust down auger trail-back by moving the tilt switch accelerometer assembly in the tilt switch mounting bracket in the same manner as the with the mercury tilt switch. Adjust the accelerometer to the right for more trail-back and to the left for less trail-back.
- b. In order to check the electronic tilt switch function and make trail-back adjustments, the electronic tilt switch must have power applied to the controller.



Failure to follow these instructions may result in injury or death.

- c. Turn OFF the main power at the shut off switch box mounted to the inside of the bin roof near the roof manhole opening.
- d. Disengage all the down auger belt drives on the trolley to prevent down auger operation and remove the fuses from the fuse holders in the track drive gear motor fuse box to prevent track drive operation.
- e. In the trolley junction box, connect a 230 volt test light or a voltmeter to the electronic tilt switch controller power-out black and white wires. There is also a red indicator light (LED) on the controller printed circuit board which will illuminate when the controller is ON and sending power to the track motor and may be used to observe power ON and OFF for trail-back adjustment. The cover of the controller enclosure must be removed to see this indicator light.
- f. Turn ON the main power at the shut off switch box mounted to the inside of the bin roof near the roof manhole opening to apply power to the Stir-Ator and the electronic tilt switch controller.
- g. Adjust down auger trail-back by observing the test light, voltmeter, or controller indicator light to determine when the track drive gear motor will turn ON.
- h. When adjustment is complete, disconnect power; remove the test light or voltmeter or re-install the cover on the controller enclosure; reengage the trolley down auger belt drives; and re-install the track drive gear motor fuses.

Solid State Electronic Tilt Switch for the Red Giant Stir-Ator

Wiring Diagrams

Red Giant Wiring Diagram - 1 Phase - 230V - 60 Hz

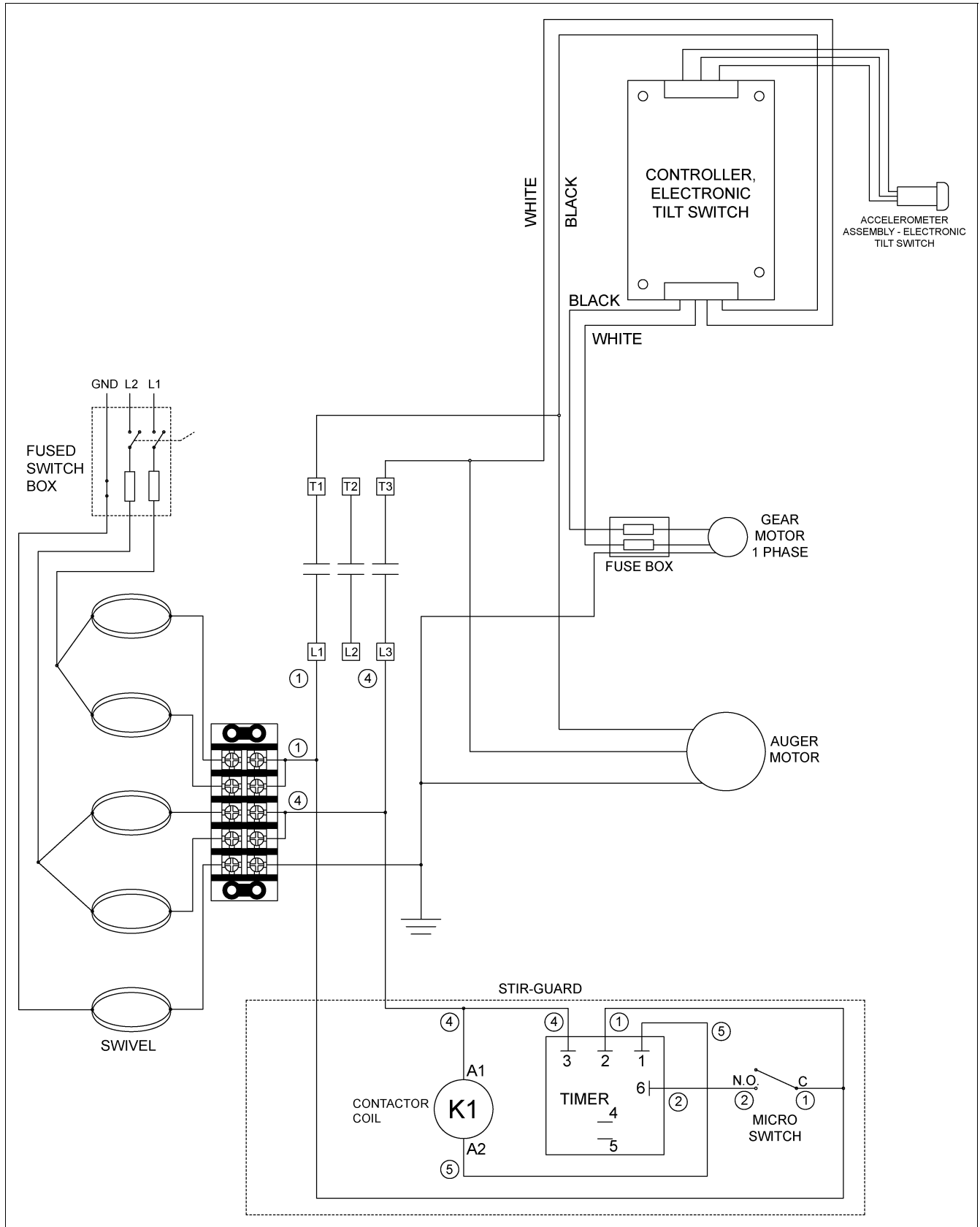

Solid State Electronic Tilt Switch for the Red Giant Stir-Ator

Red Giant Wiring Diagram - 3 Phase - 230V - 60 Hz

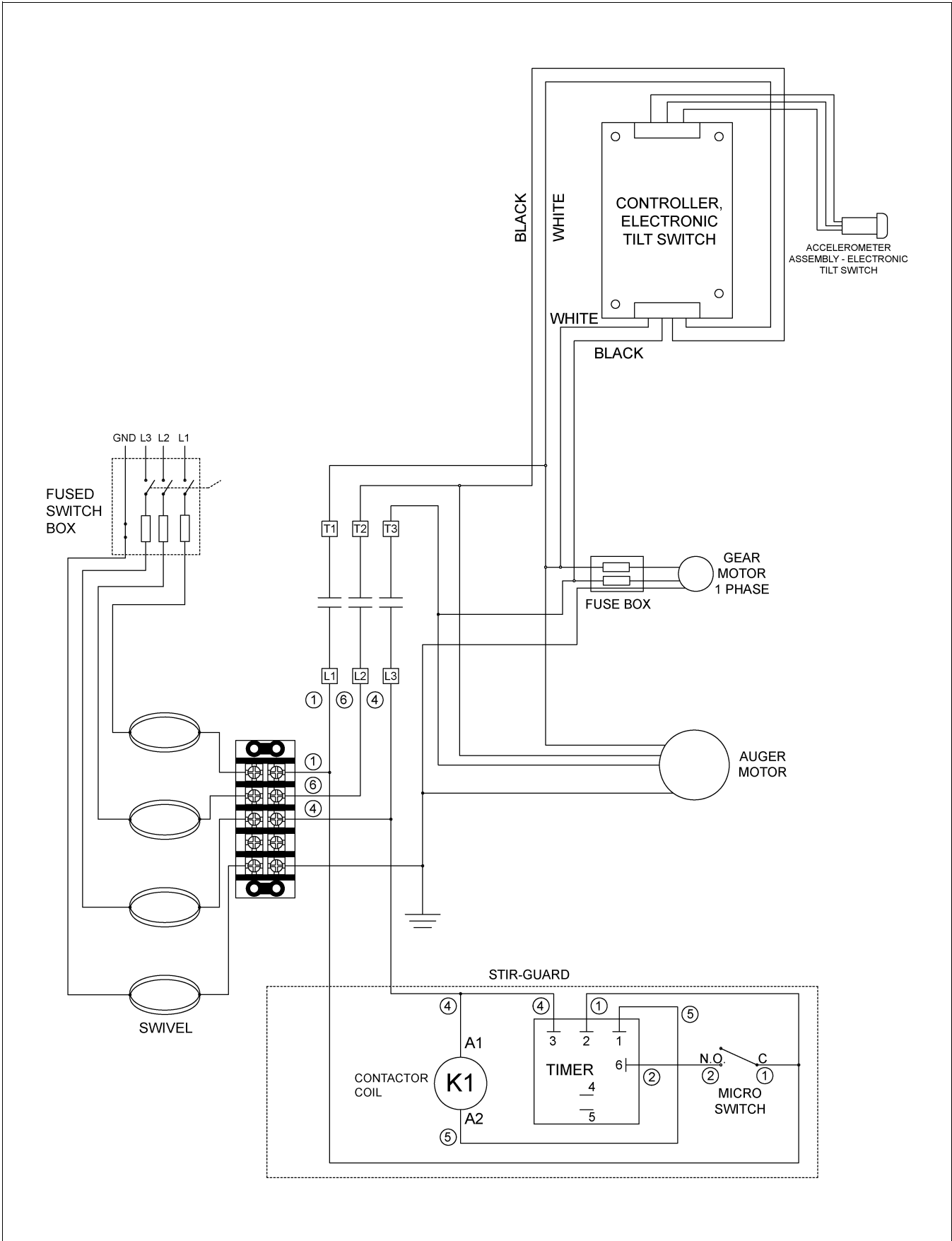

Solid State Electronic Tilt Switch for the Red Giant Stir-Ator

Red Giant Wiring Diagram - 3 Phase - 460V - 60 Hz

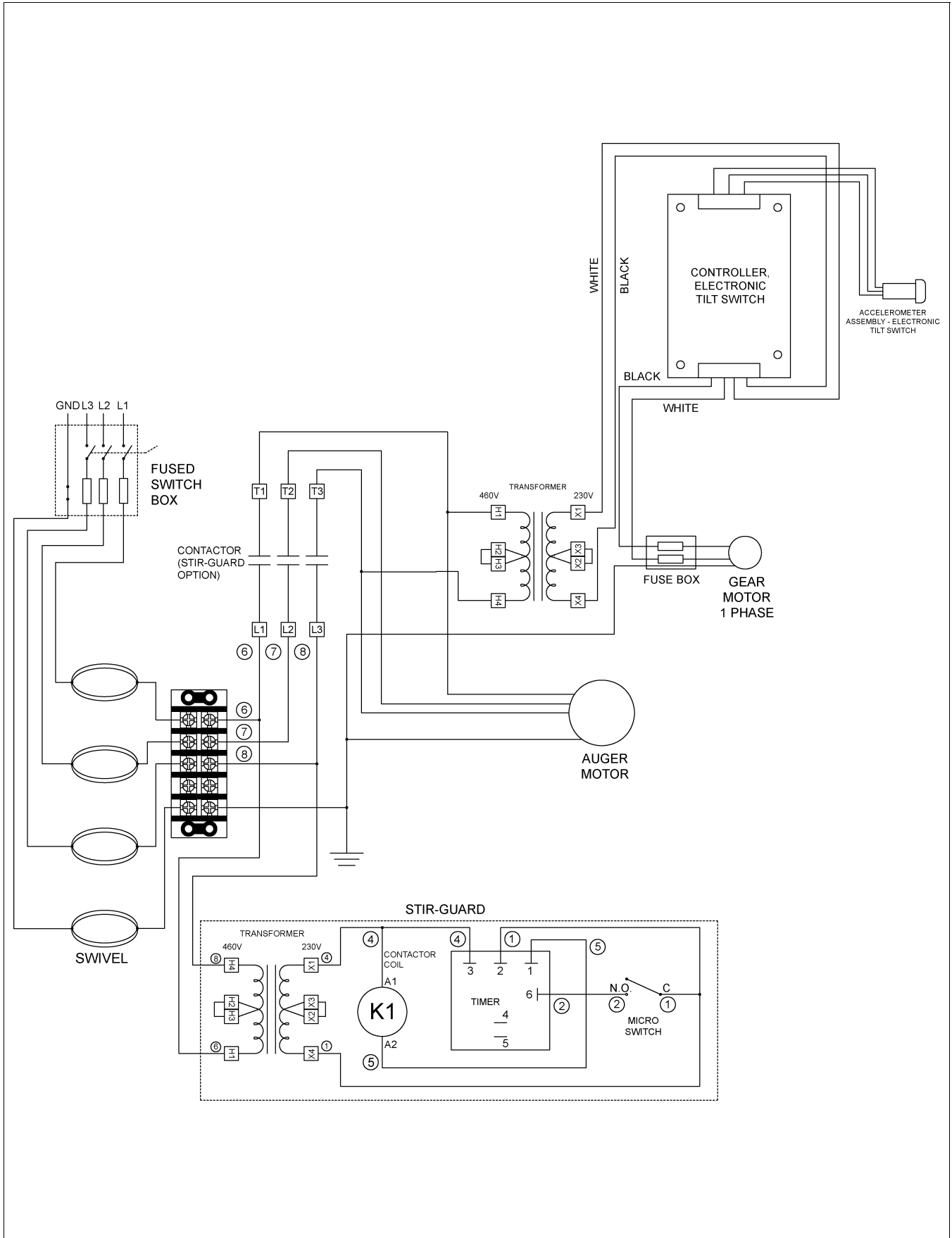

Solid State Electronic Tilt Switch for the Red Giant Stir-Ator

Red Giant Wiring Diagram - 3 Phase - 380V - 50/60 Hz

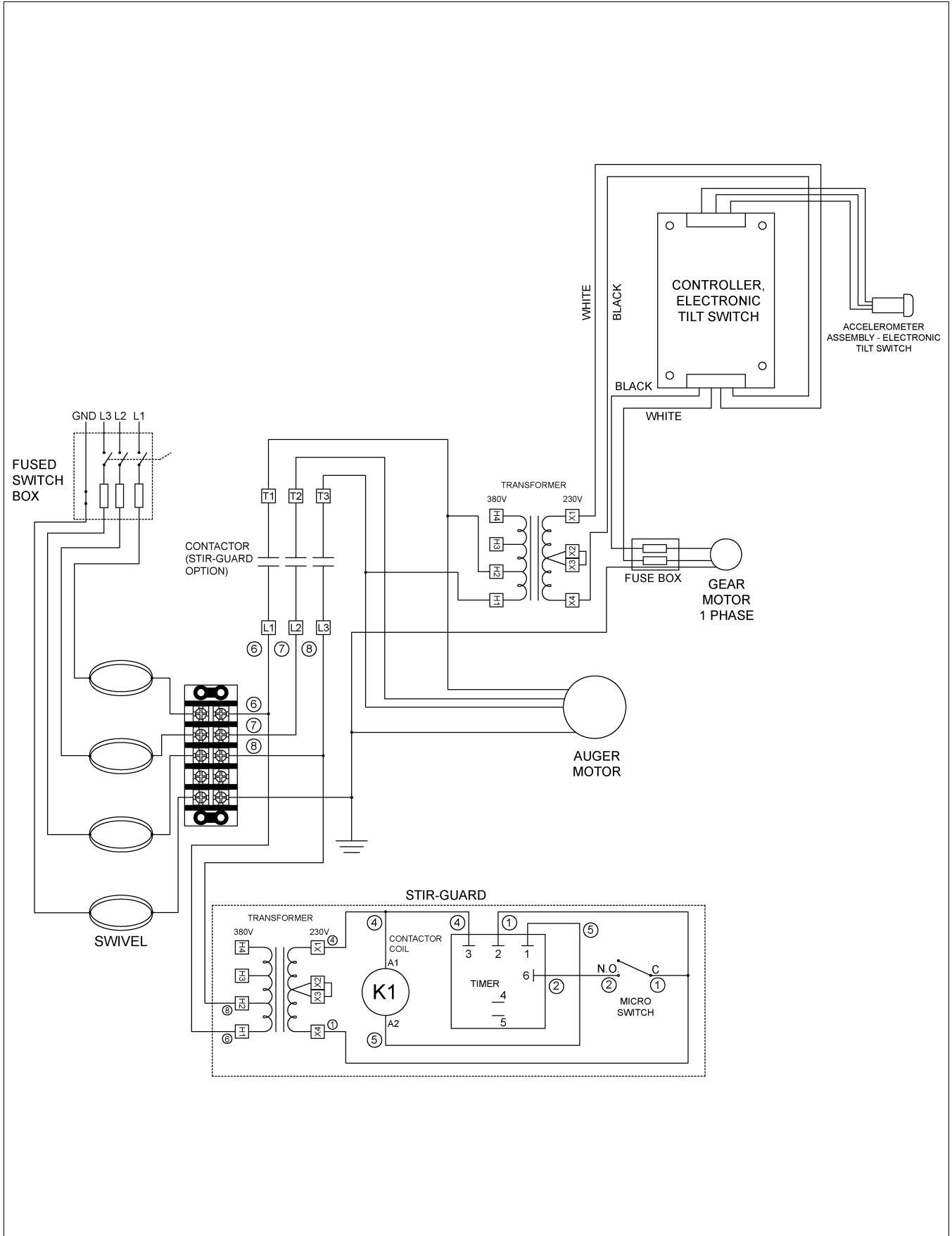

Solid State Electronic Tilt Switch for the Red Giant Stir-Ator

Red Giant Wiring Diagram - 3 Phase - 575V - 60 Hz

