



GSI Modular Tower Dryer

TM-1008, TM-1010, TM-1012 and TM-1015

Construction Manual

PNEG-1708

Date: **09-22-20**



PNEG-1708

Contents

Chapter 1 Introduction	5
Chapter 2 Safety	6
Safety Guidelines	6
General Safety Statement	7
Electrical Power Supply	7
Chapter 3 Safety Decals	8
Safety Decal # DC-GBC-1A	9
Safety Decal # DC-1943	10
Safety Decals # DC-985, DC-990 and DC-991	11
Safety Decals # DC-987, DC-988 and DC-989	12
Safety Decals # DC-1061 and 420-1473-8	13
Safety Decals # DC-1063 and DC-1064	14
Information Decals	15
Chapter 4 Dryer Overview and Specifications	16
Dimensions and Capacities for all Models	19
Dimensions - TM-1008	20
Dimensions - TM-1010	21
Dimensions - TM-1012	22
Dimensions - TM-1015	23
Chapter 5 Required Tools and Critical Tool Characteristics	24
Critical Tool Characteristics	24
Comprehensive Tool List	29
Chapter 6 Unloading and Staging the Modules	30
Chapter 7 Placing and Installing the Base/Unload Module	31
Base/Unload Module Placement Considerations	31
Securing the Unload Module	33
Chapter 8 Assembling Ladders, Platforms and Catwalks	35
Crate as Work Bench	35
Installing Outside Ladder with Safety Cage	36
Overview Catwalk and Platform Assembly	40
Attaching Catwalks and Platforms to Dryer Modules	41
Chapter 9 Lifting and Stacking the Modules	49
Overview for Safety	49
Recommended Stacking Order: Model 800 Series Dryer	50
Recommended Stacking Order: Model 1010 Series Dryer	51
Recommended Stacking Order: Model 1200 Series Dryer	52
Recommended Stacking Order: Model 1500 Series Dryer	53
Lifting	54
Chapter 10 Electrical Connections	61
Electrical Overview Minimal Connections	61
Air Switch	62
Flame Sensor and Ignitor Wires (Spark Plug)	64
Indicator, Outside Overheat and Moisture Sensor	66
Plenum Temperature	67
Chapter 11 Gas Pipe Train Overview	68
Gas Pipe Train (Natural or LP) Overview Minimal Connections	68
Chapter 12 Finishing Touches: Removing Wrinkles and Dents from Screens	70

Table of Contents

Chapter 13 Appendix A - TM-1008 Ladders	71
Chapter 14 Appendix B - TM-1010 Ladders	80
Chapter 15 Appendix C - TM-1012 Ladders	89
Chapter 16 Appendix D - TM-1015 Ladders	99
Chapter 17 Appendix E - Peak Walk Around Onsite Install Parts	114
Chapter 18 Warranty	115

READ THIS MANUAL carefully to learn how to properly use and install equipment. Failure to do so could result in personal injury or equipment damage.

INSPECT the shipment immediately upon arrival. The customer is responsible for ensuring that all quantities are correct. The customer should report and note any damage or shortage on the bill of lading to justify their claim to the transport company.

THIS MANUAL SHOULD BE CONSIDERED a permanent part of your equipment and should be easily accessible when needed.

This warranty provides you the assurance that the company will back its products when defects appear within the warranty period. In some circumstances, the company also provides field improvements, often without charge to the customer, even if the product is out of warranty. Should the equipment be abused, or modified to change its performance beyond the factory specifications, the warranty will become void and field improvements may be denied.

Safety Guidelines

This manual contains information that is important for you, the owner/operator, to know and understand. This information relates to protecting **personal safety** and **preventing equipment problems**. It is the responsibility of the owner/operator to inform anyone operating or working in the area of this equipment of these safety guidelines. To help you recognize this information, we use the symbols that are defined below. Please read the manual and pay attention to these sections. Failure to read this manual and its safety instructions is a misuse of the equipment and may lead to serious injury or death.



This is the safety alert symbol. It is used to alert you to potential personal injury hazards. Obey all safety messages that follow this symbol to avoid possible injury or death.



This symbol indicates an imminently hazardous situation which, if not avoided, **will result in serious injury or death**.



This symbol indicates a potentially hazardous situation which, if not avoided, **may result in serious injury or death**.



This symbol indicates a potentially hazardous situation which, if not avoided, **may result in minor or moderate injury**.



This symbol indicates a potentially hazardous situation which, if not avoided, **may result in property damage**.

General Safety Statement

Our foremost concern is your safety and the safety of others associated with tower dryer. This manual is to help you understand safe operating procedures and some problems that may be encountered by the operator and other personnel.

As owner and/or operator, you are responsible to know what requirements, hazards, and precautions exist and inform all personnel associated with the equipment or in the area. Safety precautions may be required from the personnel. Avoid any alterations to the equipment, which may produce a very dangerous situation, where SERIOUS INJURY or DEATH may occur.

You should consider the location of the tower dryer site relative to power line locations or electrical transmission equipment. Contact your local power company to review your installation plan or for information concerning required equipment clearance. Clearance of portable equipment that may be taken to the tower dryer site should also be reviewed and considered. Any electrical control equipment in contact with the tower dryer should be properly grounded and installed in accordance with National Electric Code provisions and other local or national codes.

This product is intended for the use of grain drying. Any other use is a misuse of the product.



This product has sharp edges, which may cause serious injury. To avoid injury, handle sharp edges with caution and always use proper protective clothing and equipment.

Sidewall bundles or sheets must be stored in a safe manner. The safest method of storing sidewall bundles is laying horizontally with the arch of the sheet upward, like a dome. Sidewall sheets stored on edge must be secured so that they cannot fall over and cause injury. Use care when handling and moving sidewall bundles.

Personnel operating or working around equipment should read this manual. This manual must be delivered with equipment to its owner. Failure to read this manual and its safety instructions is a misuse of the equipment.

NOTE: *A careful operator reduces risk of personal injury and equipment damage.*

Electrical Power Supply

GSI recommends you contact your local power company and request that a representative inspect the dryer installation. Be sure the wiring is compatible with the power company's system and that adequate power is supplied to the dryer.

3. Safety Decals

Some of the required safety decals are placed on the dryer before shipping. The remainder are placed on the dryer during electrical installations. The purpose of the safety decals is to immediately alert all personnel to the hazards of an operating dryer. The safety decal does not replace the need for all personnel to know and understand safe dryer operations and requirements. Read the “Dryer Operations and Service Manual”.

NOTE: *Safety decals should be read and understood by all people in or around the dryer area.*

Safety decals on [Pages 9-14](#) identify and give the location of all safety decals that should be on each tower dryer. Safety decals are listed in numerical order.

If the safety decals on the following pages are not on the dryer, or if they are damaged, immediately contact GSI for replacement safety decals.

GSI Decals

1004 E. Illinois St.
Assumption, IL. 62510
Phone: 1-217-226-4421

Safety Decal # DC-GBC-1A

Location of Decals

English and spanish decals are placed on inside of tower roof access port before shipping.

DANGER

 Rotating flighting will kill or dismember.	 Flowing material will trap and suffocate.	 Crusted material will collapse and suffocate.
--	---	---

Keep clear of all augers.
 DO NOT ENTER this bin!

If you must enter the bin:

1. Shut off and lock out all power.
2. Use a safety harness and safety line.
3. Station another person outside the bin.
4. Avoid the center of the bin.
5. Wear proper breathing equipment or respirator.

Failure to heed these warnings will result in serious injury or death.

GSI GROUP, INC. 217-226-4421 DC-GBC-1A



Tower roof access port with decals in place.



Inside view - Access port installed with decals in place.



Outside view - Access port installed with decals in place.

3. Safety Decals

Safety Decal # DC-1943

Location of Decal

On outside of main power box and inside main power box door.



Example - Electrical control system

<p>⚠ DANGER HIGH VOLTAGE.</p> <p>Will cause injury or death.</p> <p>Lockout power before servicing.</p> <p><small>GSI Group 217-226-4421</small></p>		<p>⚠ DANGER HAUTE TENSION.</p> <p>Causera des blessures ou la mort.</p> <p>Bloquez le courant avant de faire l'entretien.</p> <p>DC-1943</p>
--	---	---

Safety Decals # DC-985, DC-990 and DC-991

Location of Decal

Inside main power box door, on same side as main electrical disconnect.

WARNING

All maintenance procedures must be performed by qualified personnel who are familiar with the operation of this equipment. Failure to observe this warning can result in serious or even fatal injury and/or equipment damage.

DC-990

Be sure that charge light and all LED's are out before touching any components.

All test equipment should be connected and disconnected with power OFF.

Grounded test equipment, such as oscilloscopes, may damage the inverter.

Isolate all instruments from ground before using. The DC bus remains charged for several minutes after power is removed.

DC-991

FUSE TABLE 1

F#	TYPE	AMP	F#	TYPE	AMP
FU1	_____	_____	FU8	_____	_____
FU2	_____	_____	FU9	_____	_____
FU3	_____	_____	FU10	_____	_____
FU4	_____	_____	FU11	_____	_____
FU5	_____	_____	FU12	_____	_____
FU6	_____	_____	FU13	_____	_____
FU7	_____	_____	FU14	_____	_____

DC-985

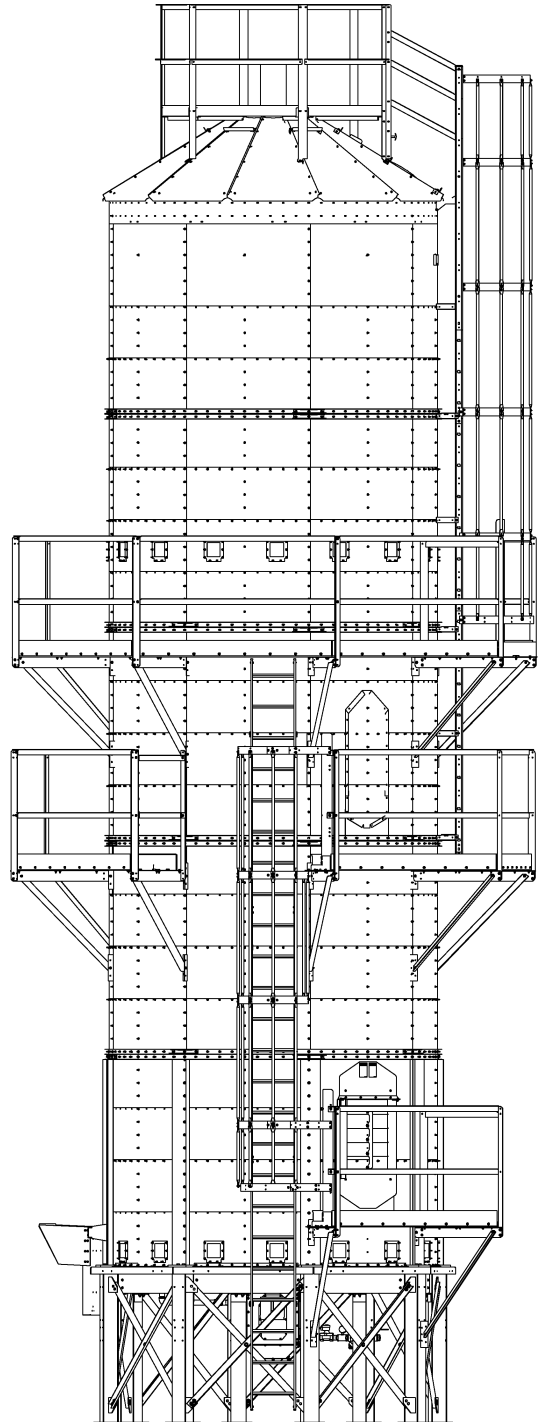

3. Safety Decals

Safety Decals # DC-987, DC-988 and DC-989

Location of Decal

Inside main power box door, on same side as main electrical disconnect.

WARNING

Ensure that the incoming AC power and all separate power sources are turned OFF and locked before working on this equipment. Failure to observe this practice may result in severe injury, death, and/or equipment damage.

DC-989

WARNING

Line side of disconnect is energized.
Hazardous voltage can shock, burn or cause death.
This unit may contain one or more voltages.

DC-987

WARNING

To maintain overcurrent short circuit and ground fault protection, the manufacturer's instructions for selecting overload relays and setting the instantaneous trip circuit breaker must be followed.

DC-988

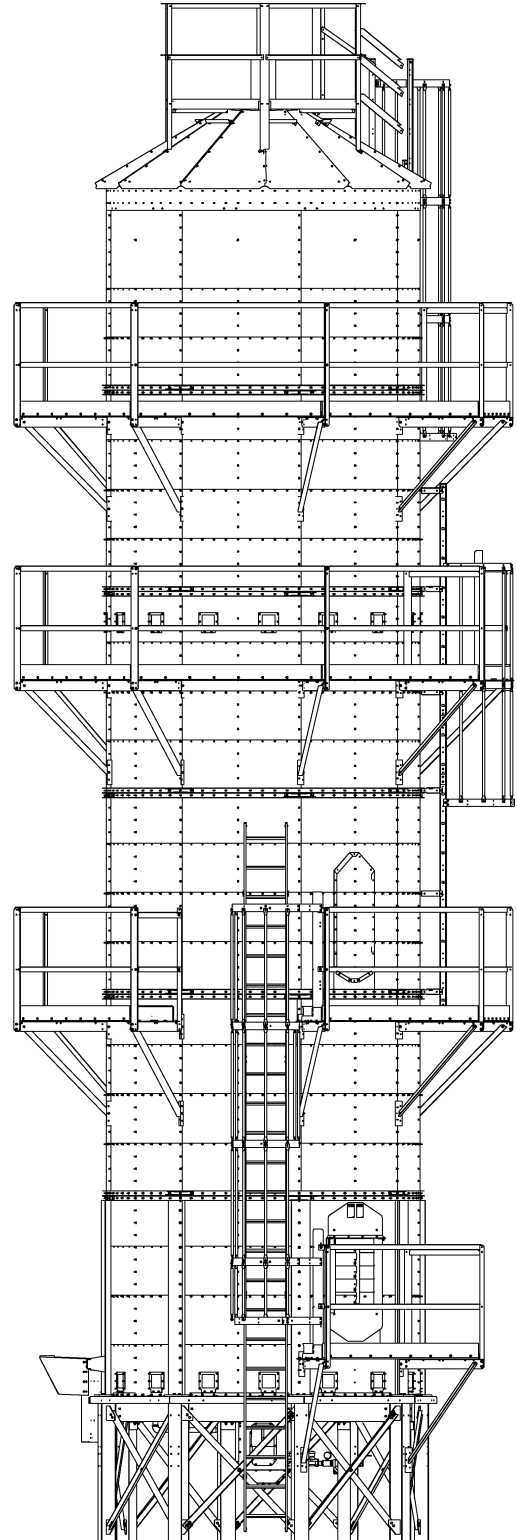

Safety Decals # DC-1061 and 420-1473-8

Location of Decal

On outside of heat module door.



 WARNING

<p>Flame and pressure beyond door. May cause serious injury. Do not enter when dryer is running.</p>
<p>GSI Group Inc. 217-226-4421 DC-1061</p>

 CONFINED SPACE
AUTHORIZED PERSONNEL ONLY
<p>420-1473-8</p>

3. Safety Decals

Safety Decals # DC-1063 and DC-1064

Location of Decal

On outside of cool module door.



! WARNING



High speed belt drive operating overhead. Can cause serious injury. Keep head and hands clear. Do not enter when dryer is running.

GSI Group 217-226-4421 DC-1064

! CAUTION



AIRBORNE PARTICLES DURING OPERATION.
May impair vision and breathing. Do not enter when dryer is running.

GSI Group Inc. 217-226-4421 DC-1063

Information Decals

Nameplate for Main Power Box

Location of Decal

Inside main power box door, on same side as main electrical disconnect.

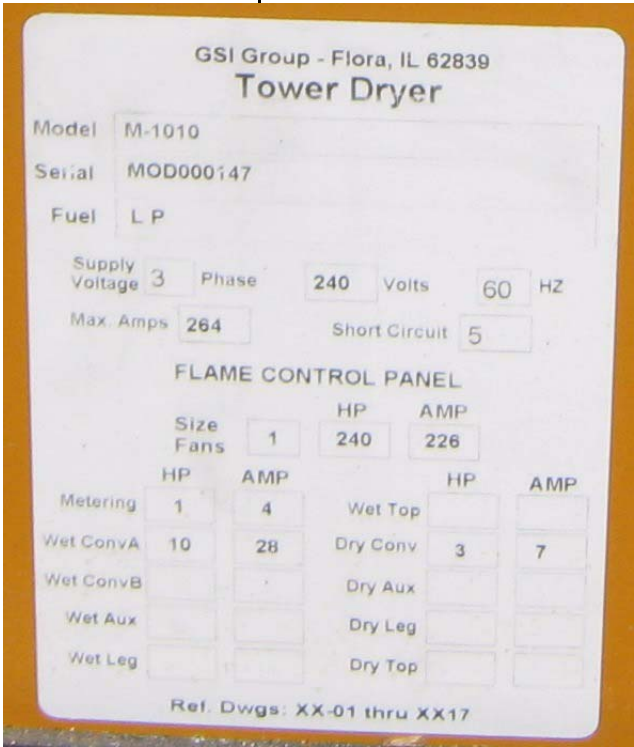

Example - Information decal

4. Dryer Overview and Specifications

All models of the GSI Modular Tower Dryer include a base/unload module, a burner/blower module, a roof module and one or more heat modules. Heat modules can be “empty” or with turners based on owner preference.

Module 1 on ALL models.

NOTE: *New dryers ship with corrugated sheets.*



Figure 4A *Base/Unload Module*

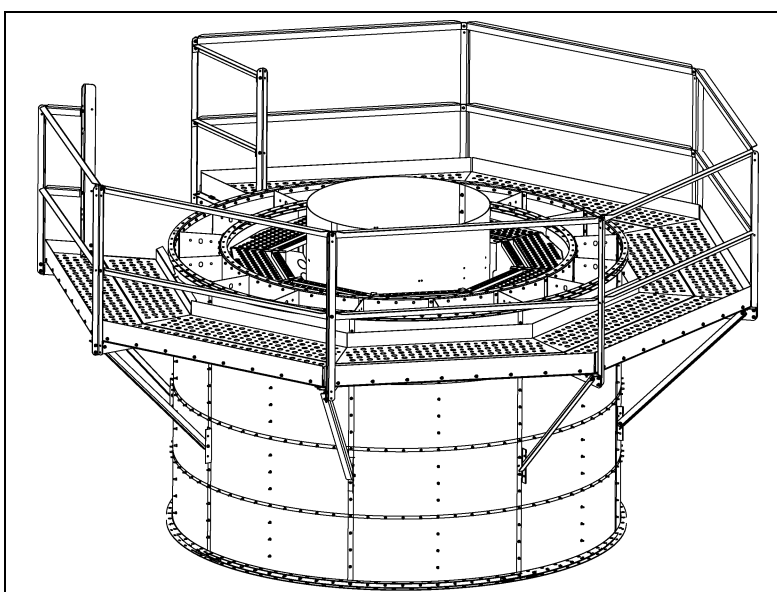

Figure 4B *Burner/Blower Module*



Figure 4C Heat Module - w/ Turners

NOTE: *TM-1010 and TM-1015 section shown. TM-1008 and TM-1012 have the turners located at the bottom of the section.*



Figure 4D Empty Heat Module

4. Dryer Overview and Specifications



Figure 4E Heat Module - w/ Door Kit



Figure 4F Roof Module

Dimensions and Capacities for all Models

There are four (4) models of the GSI Modular Tower Dryer. Each model is 10'-10" in diameter.

1. TM-1008
2. TM-1010
3. TM-1012
4. TM-1015

Model	TM-1008	TM-1010	TM-1012	TM-1015
	900	1125	1350	1690
BPH Capacity (20%-15%)	542	670	720	1010
BPH Capacity (25%-15%)	800	1000	1200	1500
BPH (Set in Maximum Cool) (20%-15%)	480	600	720	900
BPH (Set in Maximum Cool) (25%-15%)	900	1125	1350	1690

4. Dryer Overview and Specifications

Dimensions - TM-1008

Total weight = 18000 lbs.

NOTE: Please refer to [Page 49](#) for individual section weights.

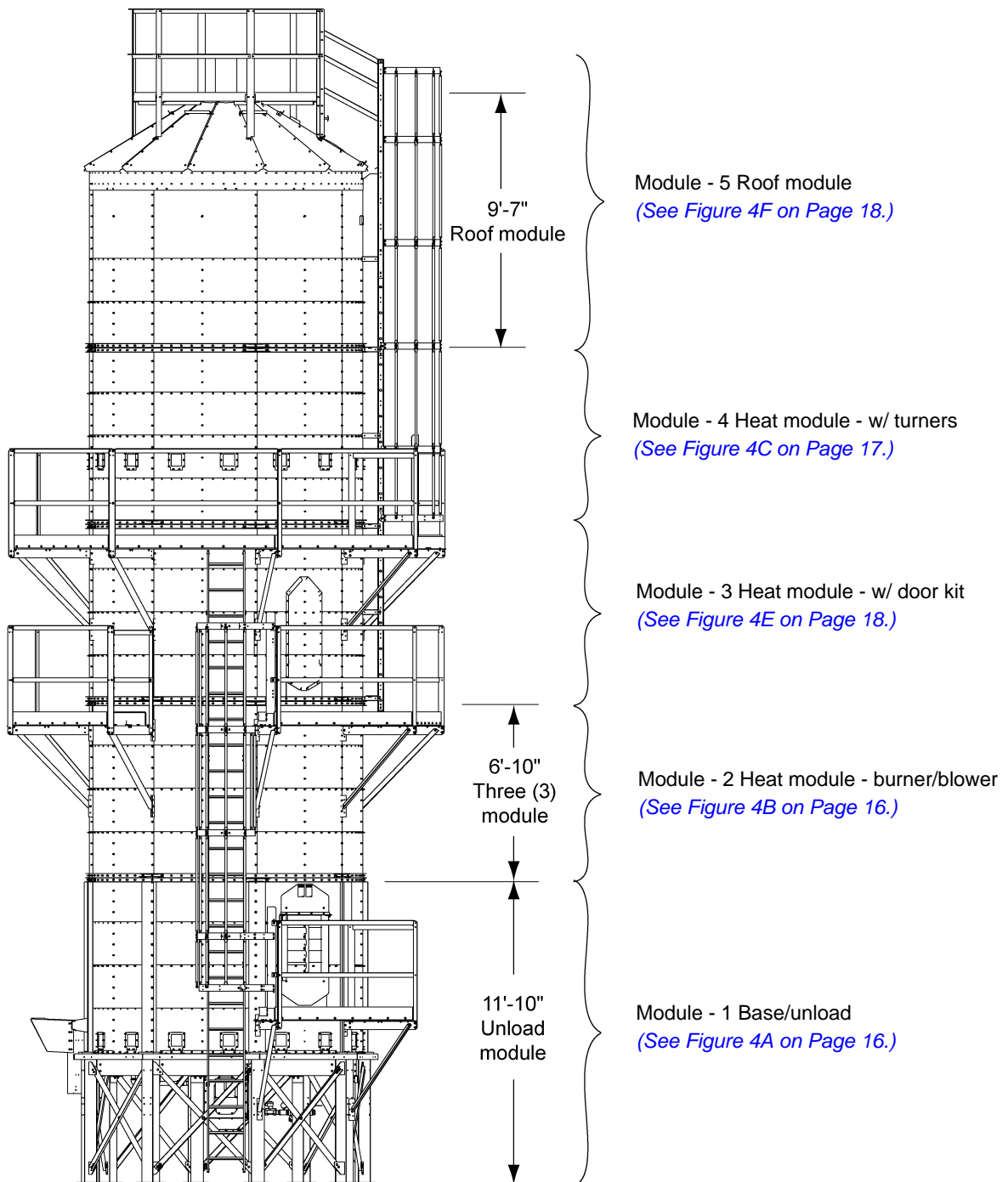

M-1008T - Five (5) modules total, usually ships on two (2) trucks. All five (5) modules are 10'-10" in diameter.

The 1008 model includes a platform at the base/unload, ladders and safety cages to a catwalks, ladders and safety cages to a full catwalk and ladders and safety cages to the roof access.

Figure 4G TM-1008

Dimensions - TM-1010

Total weight = 21645 lbs.

NOTE: Please refer to [Page 49](#) for individual section weights.

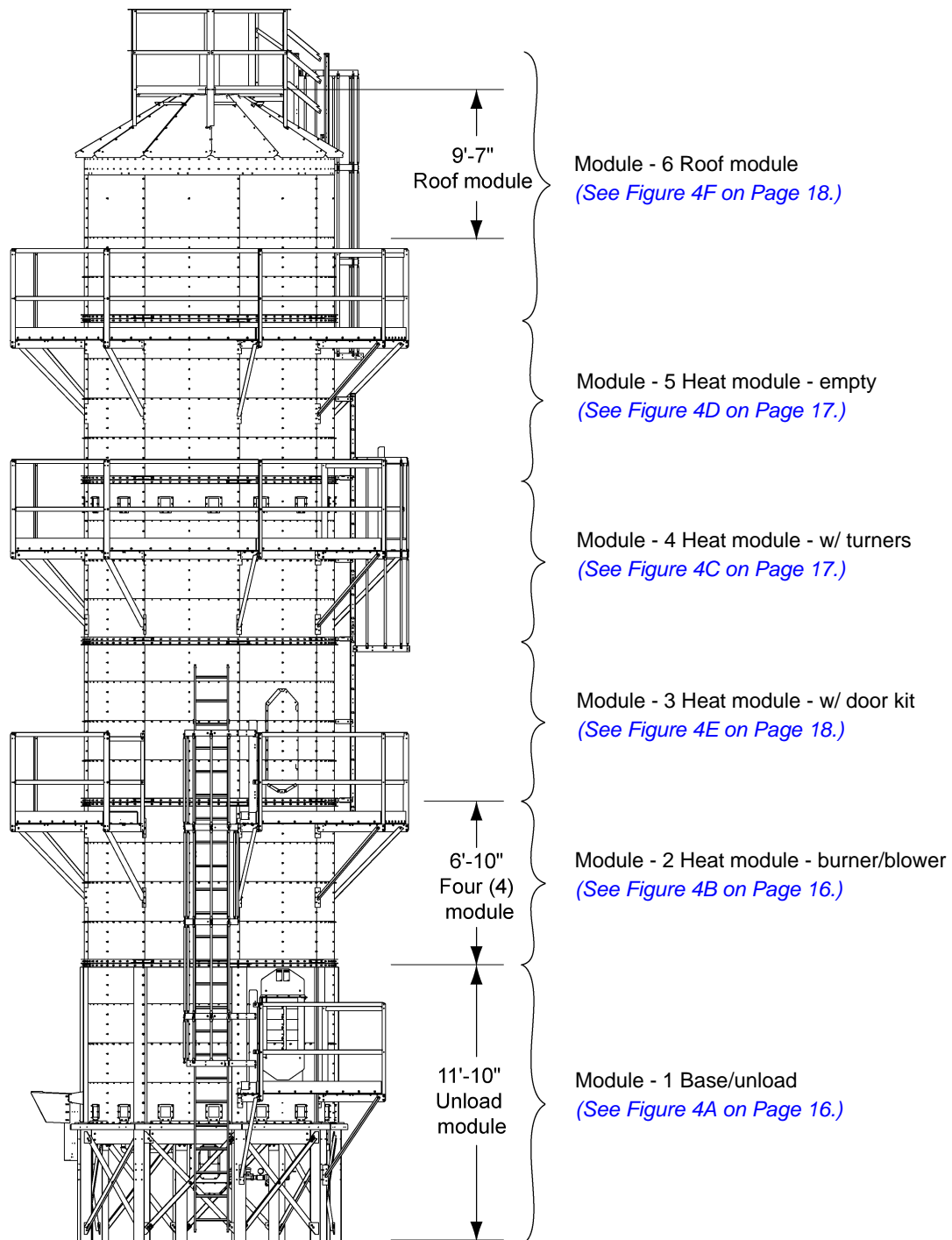

M-1010T - Six (6) modules total, usually ships on two (2) trucks. All six (6) modules are 10'-10" in diameter.

The 1010 model includes a platform at the base/unload, ladders and safety cages to three (3) full catwalks and ladders and safety cages to the roof access.

Figure 4H TM-1010

4. Dryer Overview and Specifications

Dimensions - TM-1012

Total weight = 23095 lbs.

NOTE: Please refer to [Page 49](#) for individual section weights.

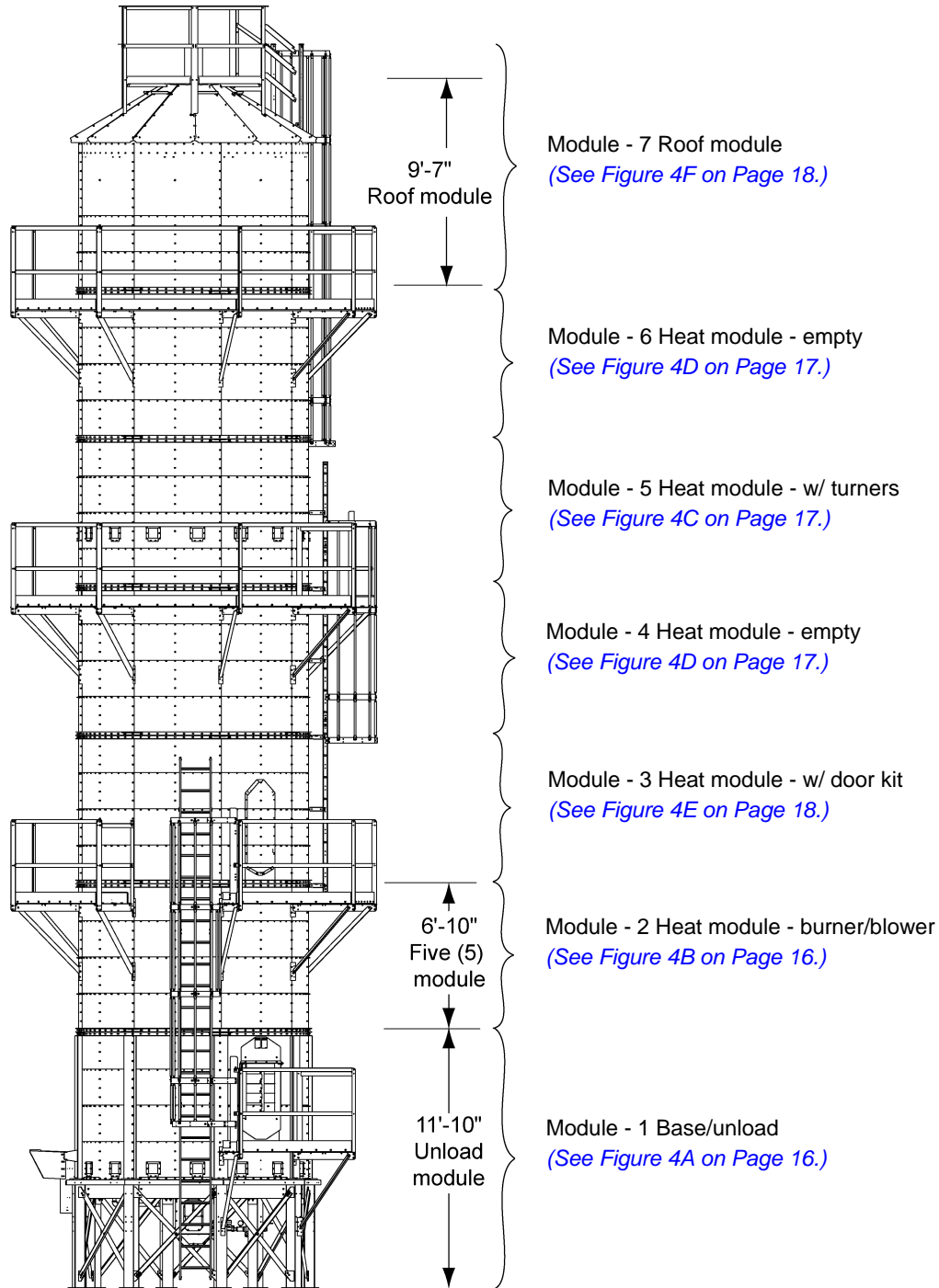

M-1012T - Seven (7) modules total, usually ships on three (3) trucks. All seven (7) modules are 10'-10" in diameter.

The 1012 model includes a platform for the base/unload module, ladders and cages to a full catwalk steppover platform, ladders and cages to three (3) catwalks and ladders and cages to the roof access.

Figure 4I TM-1012

Dimensions - TM-1015

Total weight = 24545 lbs.

NOTE: Please refer to [Page 49](#) for individual section weights.

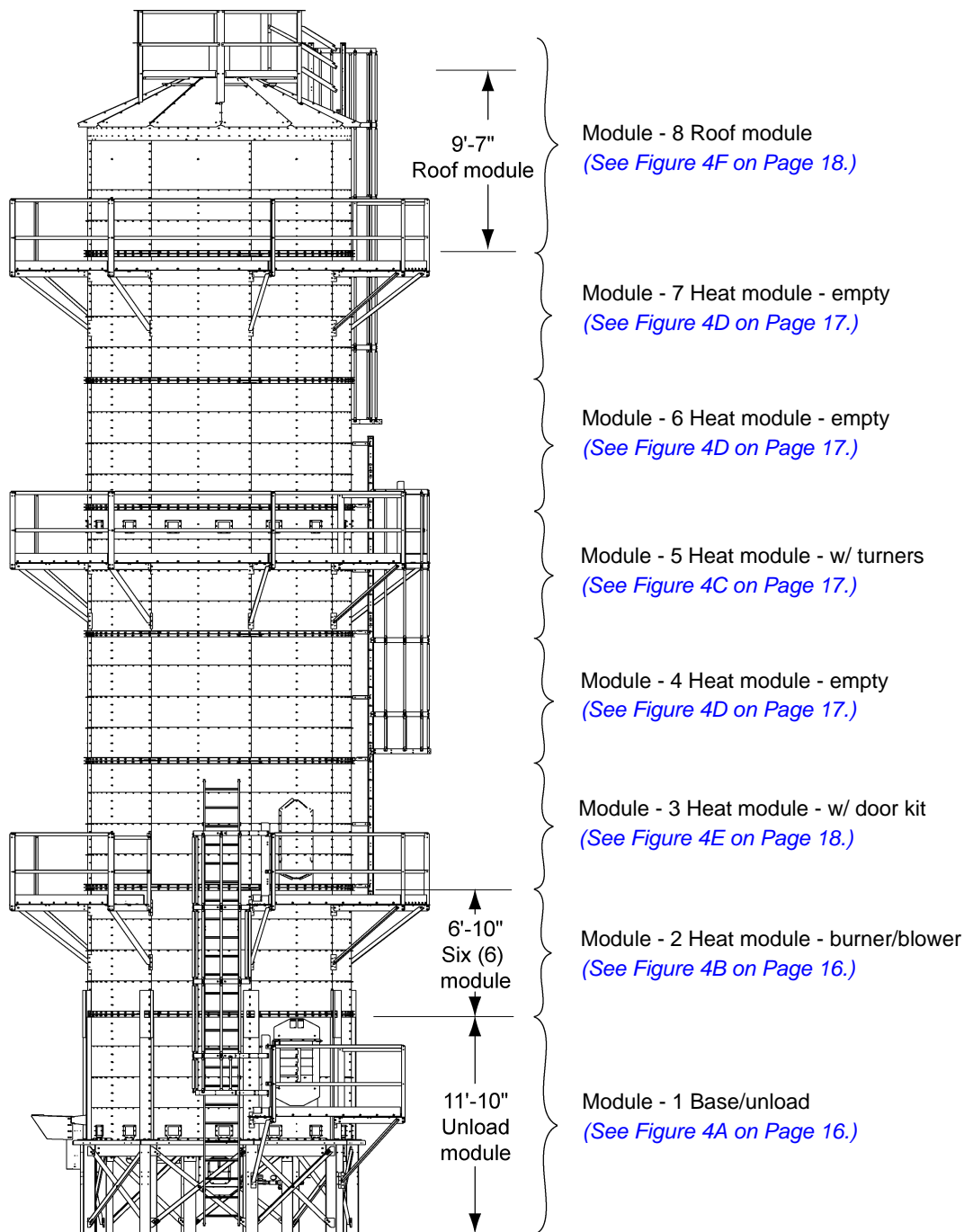

M-1015T - Eight (8) modules total, usually ships on three (3) trucks. All eight (8) modules are 10'-10" in diameter.

The 1015 model includes a platform for the base/unload module, ladders and cages to a full catwalk stepover platform, ladders and cages to three (3) catwalks and ladders and cages to the roof access.

Figure 4J TM-1015

5. Required Tools and Critical Tool Characteristics

Equipping the field crew with the right tools is essential for a smooth installation. The GSI Modular Tower Dryer requires a number of standard tools. Please pay particular attention to the following item descriptions as the characteristics of the following tools are extremely important information for proper installation. A comprehensive list of tools required to assemble and install the GSI Modular Tower Dryer is included later in this chapter.

Critical Tool Characteristics

1. **1-1/8" Hammer drill star bit at least 12" long is REQUIRED.** While the anchor bolts are 1" in diameter, the holes for the anchor bolts **MUST** be 1-1/8" in diameter to allow room for the required epoxy. Additionally, anchor bolts must be sunk deep enough so that no more than 2"-3" is above the plate.

An air compressor hose is needed to blow out the dust from the holes prior to dropping in the anchor bolts and epoxy. *(See Figure 5A.)*

2. **Air compressor with hose:** After drilled the holes for the anchor bolts, an air compressor with hose is REQUIRED in order to blow all dust and debris out of the holes.



Figure 5A Anchor Bolts Sunk - No More than 3" Remains above Plate

3. **Punches:** 5/8" Line up punches - at least 8

Ideally, during the installation process, crews will work in two (2) person teams with one team working inside the dryer and one team working outside the dryer. Each crew member should have at least two (2) punches available to them and a hammer.

Punches should be long enough to provide significant leverage to the user and should have narrow and pointed tips to facilitate the initial punch placement. *(See Figure 5B and Figure 5C on Page 25.)*

5. Required Tools and Critical Tool Characteristics



Figure 5B *Line Up Punch and Hammer*



Figure 5C *Line Up Punch Inserted Through Connecting Channels of Dryer*

5. Required Tools and Critical Tool Characteristics

4. Socket sets and impact wrenches:

- 3/8" Drive 1/2" socket set
- 3/8" Drive 9/16" socket set
- 1/2" Drive socket set
- 15/16" Deep well 1/2" drive sockets
- 1/2" Deep well 1/2" drive sockets
- Short 1/2" 1/2" drive sockets
- 9/16" Deep well 1/2" drive sockets
- 1/2" Impact wrenches
- 3/8" Drive extensions (6" to 10") for 9/16" shallow socket

Accessing the bolts that connect sections of the dryer together requires passing through the hole in the channel as shown in [Figure 5D](#).

When installing, **in all possible situations, place the impact on the bolt.** Do NOT tighten the nut as it will not lock down on the ring. Always tighten the bolt. ([See Figure 5D.](#))



Figure 5D Connecting channels often requires the use of socket extensions. Please plan accordingly.

5. Required Tools and Critical Tool Characteristics

5. **Laser transit level tool:** After placing the unload/base module on the concrete foundation and establishing its proper orientation to other equipment it must be leveled. **GSI strongly recommends using a Laser transit leveling tool to level the unit.** (See Figure 5E.) If a Laser transit is not available, a carpenter's level may be used.

It is critical to establish the base/unload module as level. **Even a minor deviation at this level will be a significantly greater deviation at the top section.** Therefore, pay particular attention to confirming the levelness of the base/unload module. Shims are available to assist with leveling the base/unload module. (See Figure 5F.)



Figure 5E Laser Transit Level



Figure 5F

5. Required Tools and Critical Tool Characteristics

- a. **Compression channel:** Regardless of what leveling tool is used, the proper reference point for leveling the unload module of the dryer is the **Compression Channel** and NOT the base/leg plates on the concrete. *See Figure 5G* for reference.

The **Compression Channel** is the “ledge” around the unload module of the dryer. Use this as the reference point for leveling the unit. Do **NOT** use base plates/feet to determine whether or not unit is level.



Figure 5G Unload Module with Compression Channel Marked

Comprehensive Tool List

- C6 Epoxy gun
- 1/4" Line up punches
- 1/2" x 9/16" Box end combination wrenches
- 1/2" Open end wrenches
- 9/16" Open end wrenches
- 32 OZ Ball peen hammers
- 5/8" Line up punches
- Small pry bars
- 3/8" Drive socket and extension
- 3/8" Drive 1/2" socket set
- 3/8" Drive 9/16" socket set
- 1/2" Drive socket set
- 4' Level
- Vice grips
- 25' Tape measures
- 15/16" Wrenches
- 15/16" Deep well 1/2" drive sockets
- 1/2" Deep well 1/2" drive sockets
- Short 1/2" 1/2" drive sockets
- 9/16" Deep well 1/2" drive sockets
- Caulk gun and 2 tubes of clear silicone
- 36" Pipe wrenches (rigid aluminum)
- 48" Pipe wrench (rigid aluminum)
- 18" Pipe wrenches
- Torque wrench (all 3/8" grade 8 bolts will need 45 ft./lbs.)
- 20' Ladders
- 6' Ladders
- 3/8" High speed drill bits
- 5/16" High speed drill bits
- 1/2" Impact wrenches
- 1/2" Drills
- 1-1/2" Sockets
- Cordless sawzall
- 1-1/2" Hammer drill
- 1-1/8" Bits (hammer drill star bits)
- 3/8" and 5/16" Bit for impact driver
- 100' with a four (4) way box
- Air compressor with hose



6. Unloading and Staging the Modules

1. Place modules on ground that is as solid and level as possible. Soft ground/grass will make preparation for installation more difficult. Concrete or gravel ground is preferable for pre-installation work. If no gravel or concrete area is available for staging the modules, consider placing the modules on 2 x 4's or other blocking material to prevent the modules from sinking into the ground. Use 8' blocks that are 2' long sitting on inside, outside rings/sitting on channels level as possible.
2. Place modules next to sequential modules (i.e. place Module 2 near Module 3 and Module 3 near Module 4, etc.) to make the stacking and connection of multiple modules easier.
3. Leave at least 4' to 5' of space between each module. Catwalks and/or platforms are attached to appropriate modules before modules are stacked upon each other and lifted into place.
(See Figure 6A.)

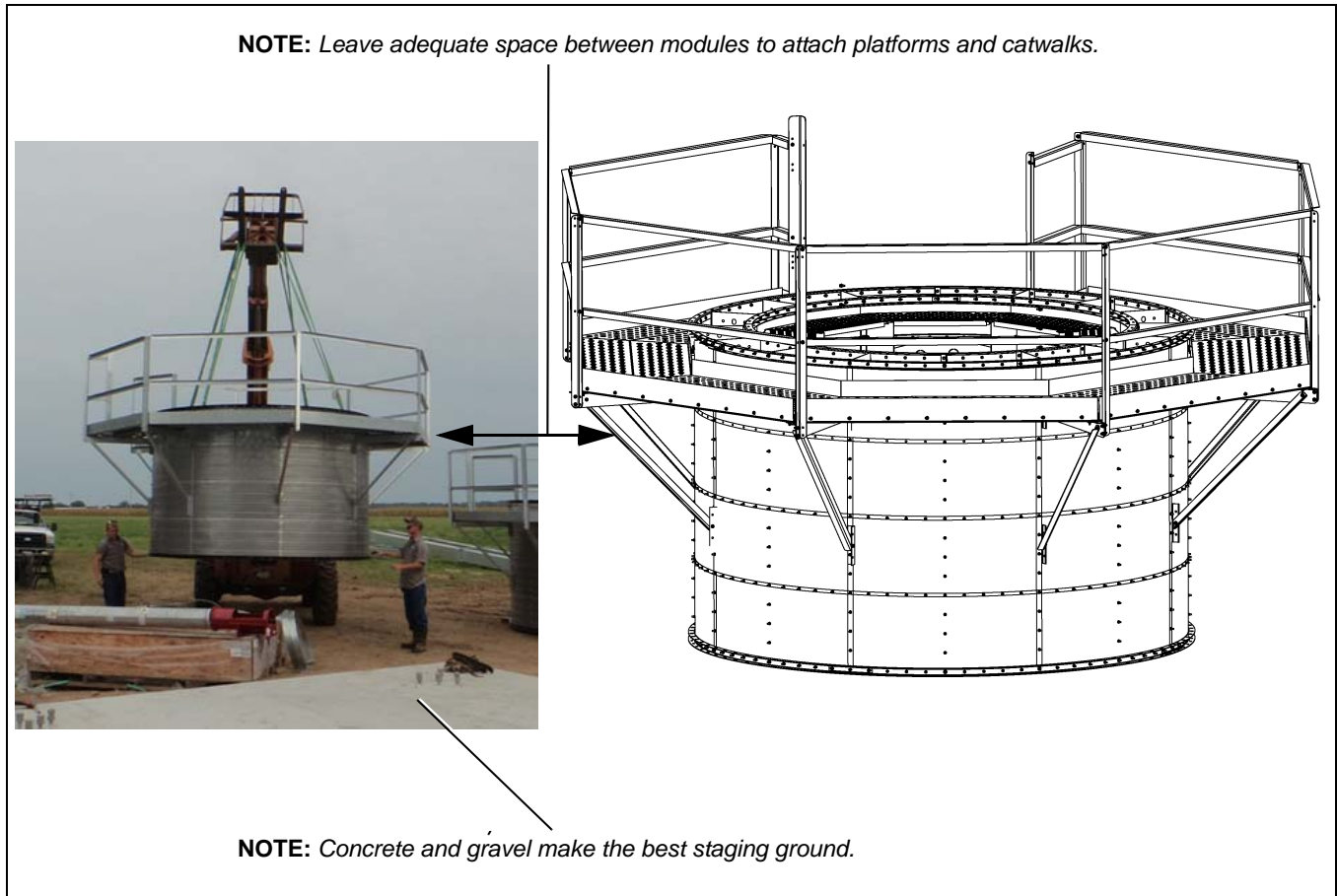

Figure 6A Unload and Staging Considerations

Base/Unload Module Placement Considerations

If the concrete foundation is ready and adequately cured, place the base/unload module on it and take careful and complete consideration of the surrounding equipment. Be sure to consider any planned options such as augers and any potential equipment to be added later.

1. Consider the location of the electrical box and control panel. Orient base/unload module so that personnel will have adequate and safe access to the electrical box and control panel. Remember, the Vision control box can be remote mounted. (See [Figure 7A.](#))
2. Consider any auxiliary equipment that will be used with the GSI Modular Dryer. One set of X-braces on the unload may be removed without compromising structural integrity to allow for easier access.
3. Ensure that there is adequate overhead clearance for the entire tower dryer height and that the clearance between the dryer walls and other equipment is sufficient to allow for catwalks and/or platforms. (See [Figure 7B on Page 32.](#))



Figure 7A

7. Placing and Installing the Base/Unload Module



Figure 7B Consider overhead clearance for the entire height of the dryer.

4. Ladder brackets are not pre-installed on modules. Consider installation location of ladders and brackets. Note that ladder brackets will be offset at each catwalk and will not line up in a straight line. (See Figure 7C.)

IMPORTANT: When planning dryer location, ladders brackets will serve as good reference point for where catwalks and/or platforms will be placed higher up on the dryer. Be sure to allow for adequate spacing and clearance between the module dryer wall AND the platforms and/or catwalks that will be attached higher up and any other equipment in the area.



Figure 7C Ladder Brackets - Identify location on each module and surrounding equipment considerations.

Securing the Unload Module

1. After determining the orientation of the unload module, use a 1-1/8" drill bit at least 12" long to drill holes for the anchor bolts.

NOTE: Anchor bolts are 1" in diameter but the hole for them must be 1-1/8" in diameter to allow for the required epoxy.

NOTE: It may be necessary to remove one X-brace to gain easier access to the holes for the anchor bolts. If X-braces are removed or loosened to drill the anchor bolt holes, be sure to tighten the X-braces again when done.



While it is normal to encounter rebar on occasion when drilling the holes for anchor bolts, should this happen more than 3 or 4 times, it is necessary to contact GSI for splice plates to complete the drilling of the anchor bolt holes. (See Figure 7D.)



Figure 7D

2. Use a laser transit to level the unload module.

IMPORTANT: ALWAYS use the compression channel as the point of reference for establishing the levelness of the unit. Never use the feet/anchor plates to determine levelness. (See Figure 7E.)



Figure 7E

7. Placing and Installing the Base/Unload Module

NOTE: Shims are provided to assist with leveling if necessary. (See Figure 7F.)

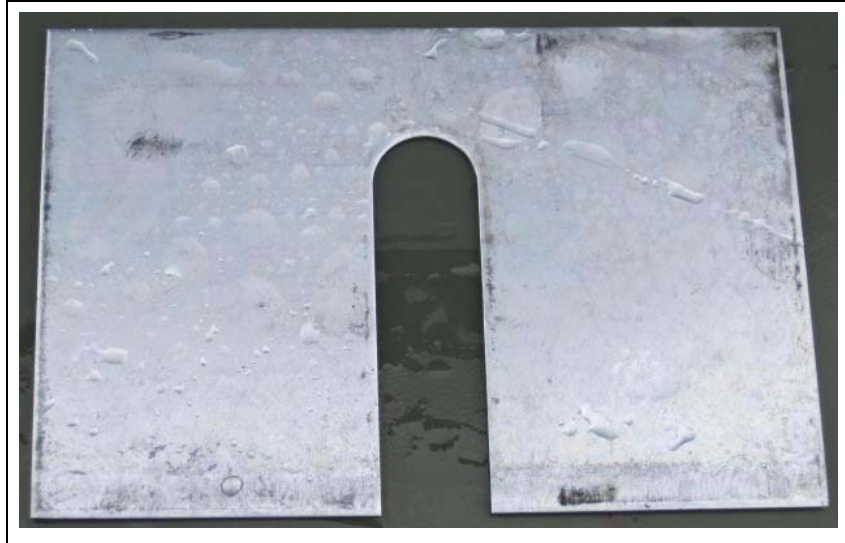

Figure 7F

3. After drilling the holes, all debris and fine material must be removed from the holes.
4. Use a compressed air hose to blow the dust and debris out. Then, drop anchor bolt in holes to confirm depth is adequate.
5. Once the unit is level, fill anchor bolt holes approximately 1/2" full with the provided epoxy. Press anchor bolts in holes. (See Figure 7G.)

NOTE: Epoxy should not ooze above concrete. If epoxy does this could interfere with shims. No more than 2" to 3" of the bolt should remain above the plate. (See Figure 7G.)

6. After all anchor bolt holes have been filled with epoxy and all anchor bolts have been inserted into the holes to the proper depth, allow epoxy to set for 4 to 6 hours before installing and tightening nuts or stacking another module of the dryer on top of it.



Do NOT remove more than one set of X-braces on the base/unload module as doing so may compromise the structural integrity of the dryer. One set may be removed to accommodate auxiliary equipment.



Figure 7G

Crate as Work Bench

Because the base/unload module requires the epoxy to set for a MINIMUM of 4 hours before other modules can be set on top of it, this is an excellent time to begin assembly of the catwalks. Once the crate is empty, use a hammer to pound the exposed nails and/or staples back into the frame so that the surface is smooth.

The crate makes an excellent work bench for assembling items throughout the installation process. (See [Figure 8A](#) and [Figure 8B](#).)



Figure 8A *Crate as Work Bench*

Once the modules have been staged, open the crate that shipped with the dryer modules.

The crate contains catwalk and/or platform materials, ladders and safety cages, as well as the hoses for pipe train.

Optional items such as an auger kit will also ship in crates. Installation instructions for optional accessories are in separate installation manuals.

Unload the materials from the crate and place them nearby in like-item groups (i.e. gas train pipes together, catwalk and platform flooring together, etc). (See [Figure 8B](#).)



Figure 8B *Shipping Crate*

8. Assembling Ladders, Platforms and Catwalks

Installing Outside Ladder with Safety Cage

NOTE: Refer to the appendix sections on [Pages 71-99](#) for ladder layout and positioning.

Outside Ladder Bracket

Outside ladder brackets are not pre-installed prior to shipping. Pre-assemble safety cages on the ground prior to attaching to the dryer.

Top Safety Cage

Pre-assemble the top safety cage as follows. (See [Figure 8C](#), [Figure 8D](#) below and [Figure 8F](#) to [Figure 8H](#) on [Page 37](#).)

1. Snug bolt one formed ladder section to two (2) outside ladder stiffeners. Snug bolt four (4) safety cage brackets to outside ladder stiffeners. (See [Figure 8C](#).)

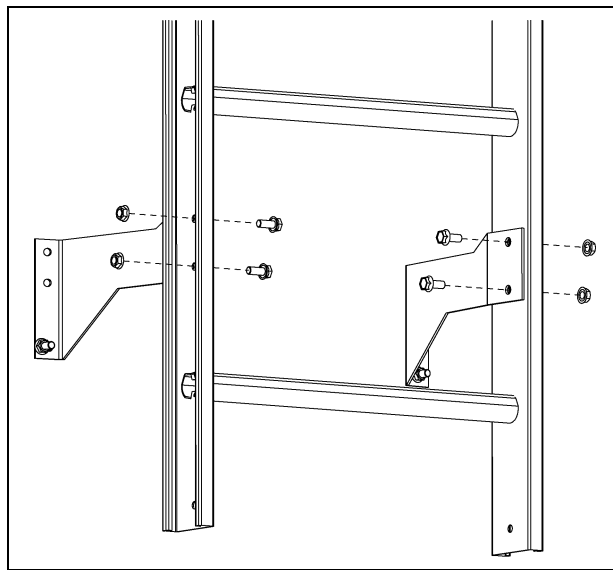

Figure 8C

2. Bolt pairs of safety cage hoop halves together. (See [Figure 8D](#).)

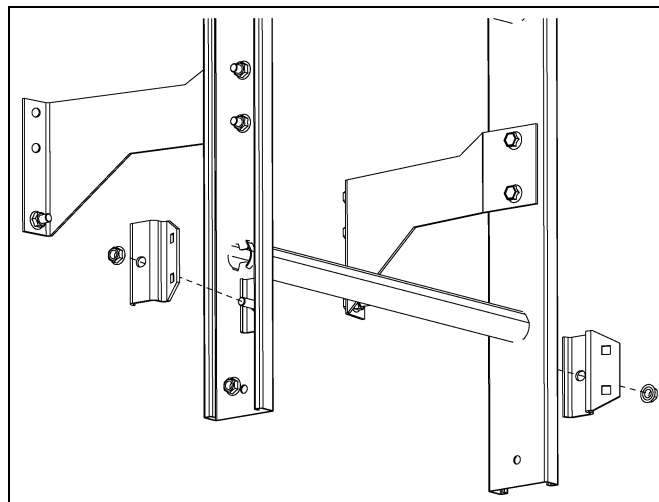

Figure 8D

8. Assembling Ladders, Platforms and Catwalks

3. Snug bolt safety cage hoops to safety cage brackets. *(See Figure 8E and Figure 8F.)*

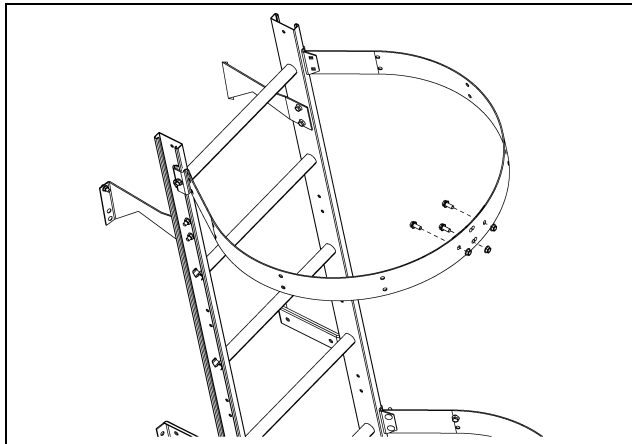

Figure 8E

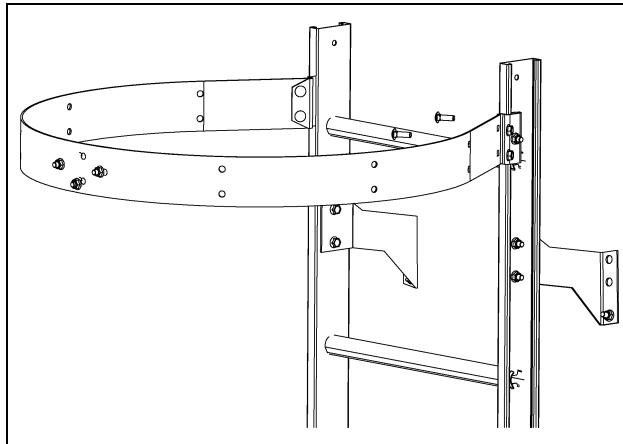

Figure 8F

4. Snug bolt seven (7) vertical supports to safety cage hop halves. *(See Figure 8G.)*
5. Snug bolt top safety cage assembly to outside ladder brackets. *(See Figure 8G.)*
6. Tighten all bolts.
7. Use splice plate between ladders sections to connect. *(See Figure 8H.)*

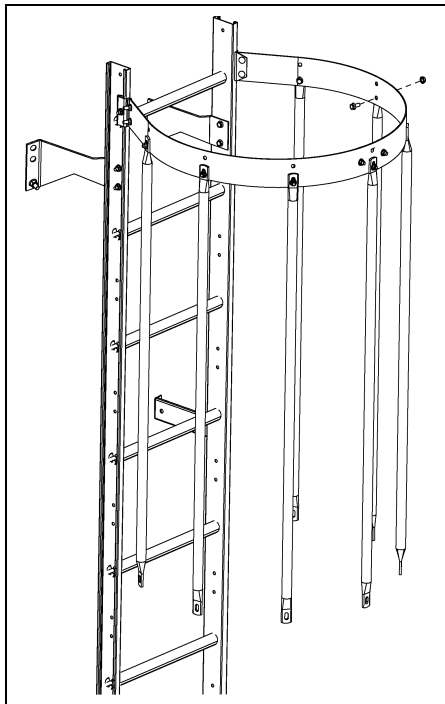

Figure 8G

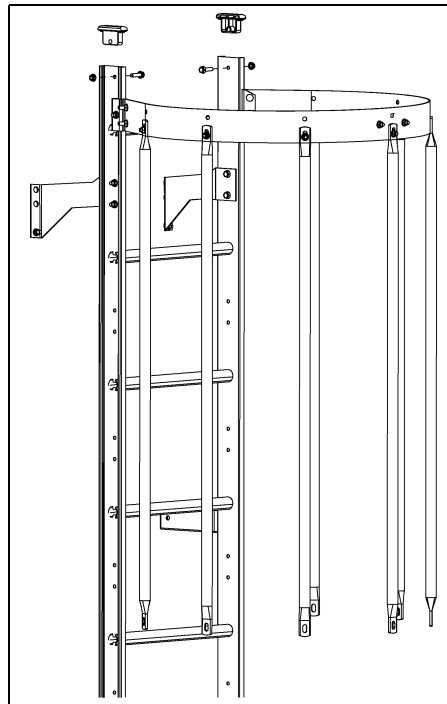

Figure 8H



LADDER BOLTS - insert bolts toward outside of ladder, so climbers do not snag on bolt shafts.



Install all formed ladder sections so rungs with rough, textured side for gripping are on top, so climbers do not slip.

8. Assembling Ladders, Platforms and Catwalks

Safety Cage Extensions

Install safety cage extensions from top safety cage to bell safety cage just above foundation as follows.

Quantity depends upon dryer model.

1. Splice outside ladder stiffeners with ladder stiffener splices. Snug bolt outside ladder stiffeners behind formed ladder sections. (See Figure 8I.)

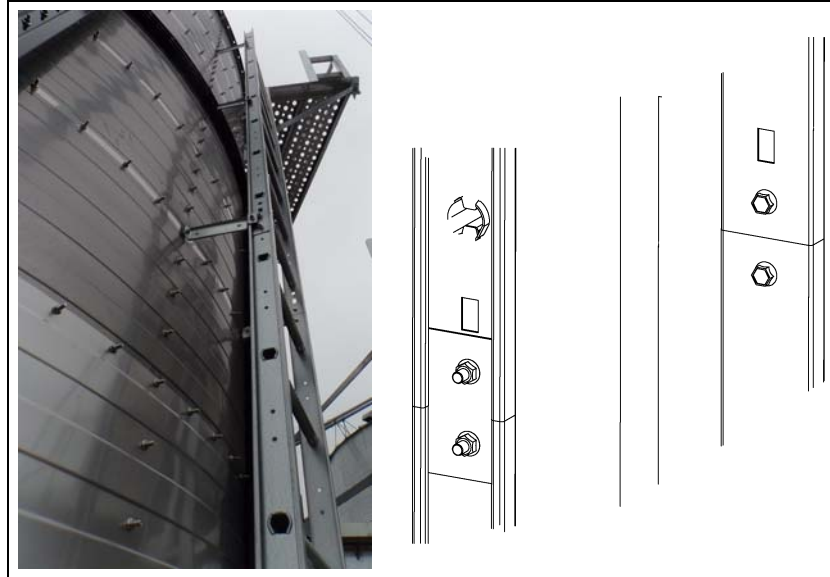

Figure 8I Close Up - Ladder Stiffener Splice

2. Install safety cage brackets and safety cage hoops like top safety cage.
3. Before lifting each section, tighten bolts in outside ladder with safety cage for that section.

As dryer is constructed, continue installing safety cage extensions to each section of dryer before lifting it. (See Figure 8J.)

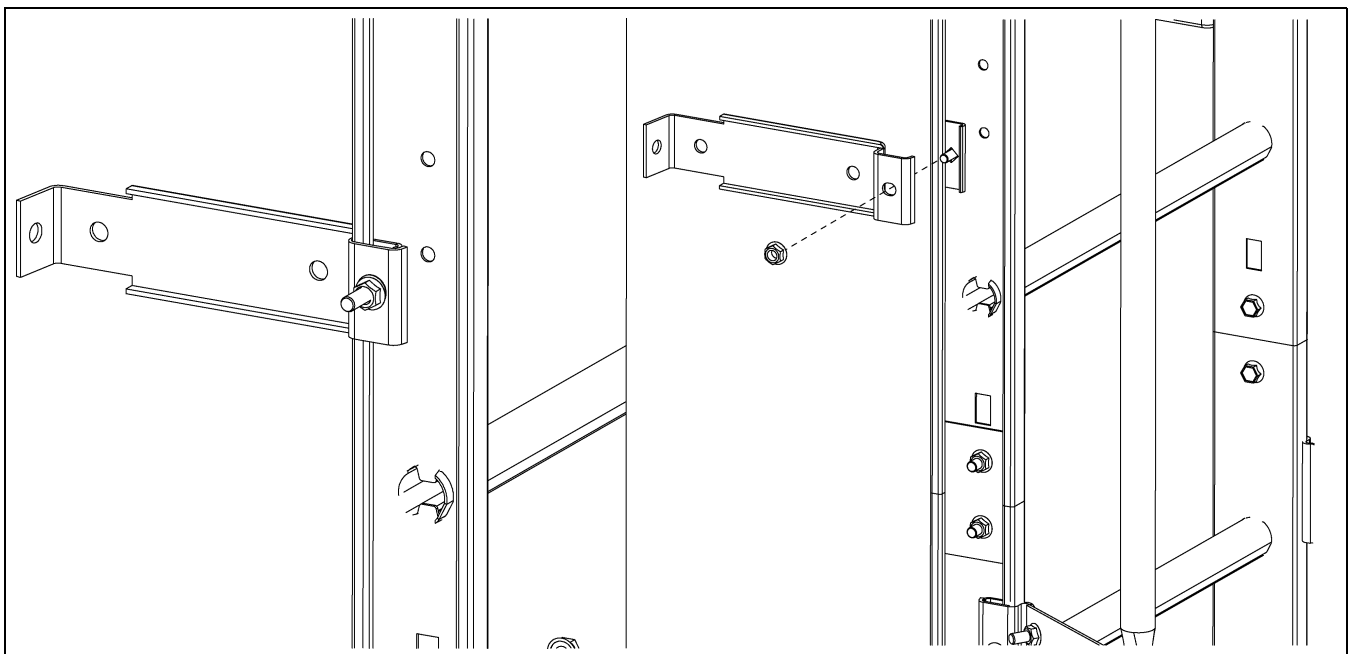

Figure 8J Close Up - Outside Ladder Brackets



Figure 8K *Ladder Bracket for Rings*



Figure 8L *Ladder Bracket for Sheets*

8. Assembling Ladders, Platforms and Catwalks

Overview Catwalk and Platform Assembly

NOTE: This is a basic overview of the process as it relates to the Modular Tower Dryers and is intended to be a general guide for catwalks and platforms as they are assembled on the GSI Modular Tower Dryer.

Catwalk and platform parts are shipped in the shipping crate that accompanies the modules. Assemble all floor planks and kick plates before assembling the dryer or stacking and connecting the modules. Use the shipping crate as a work bench to assist in the assembly of kick plates, catwalks and platforms.

1. Match longer kick plates to longer catwalk platforms and match shorter kick plates to shorter catwalk platforms.
2. Attach kick plates to planks with nuts and bolts. For safety purposes, all nuts should be to the inside.
3. Tighten fully with power impact. (See Figure 8M and Figure 8N.)

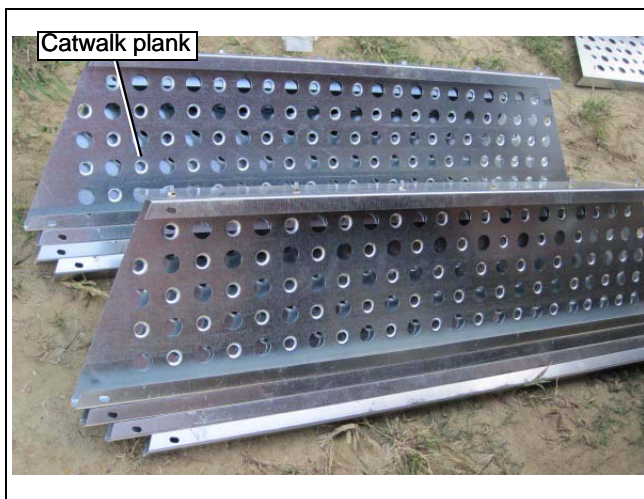

Figure 8M Catwalk Planks

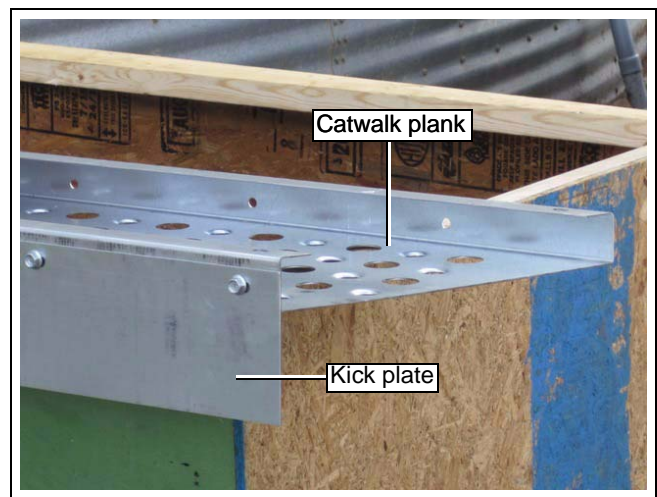

Figure 8N Kick plate attached to catwalk plank.
Assembled on shipping crate as work bench.
NOTE: The assembly is shown lying upside down.

4. Attach the curved kick plates to the catwalk planks that will be used at the stepover sections immediately off of ladders. Curved kick plates are provided for safety purposes and help prevent feet or boots from slipping and getting wedged between the platform and the dryer wall. (See Figure 80.)

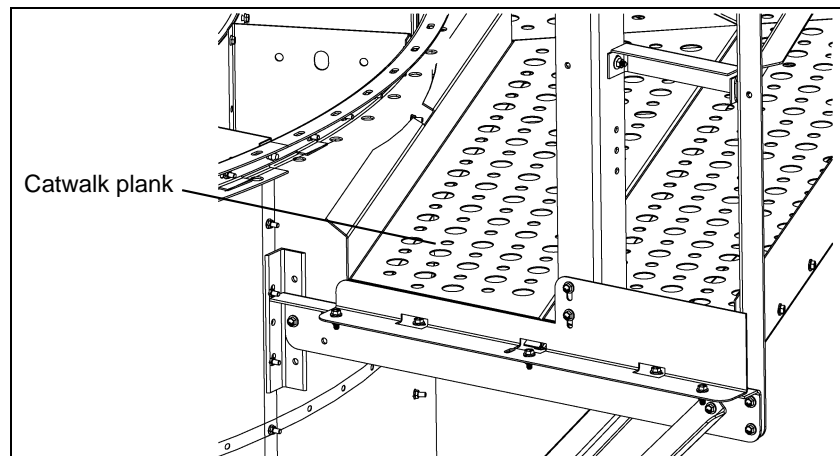

Figure 80 Catwalk plank with curved kick plate for use at stepover locations.

Attaching Catwalks and Platforms to Dryer Modules

Catwalks and platforms are attached to the appropriate modules while they are on the ground, before modules are stacked on other modules or lifted into place on the unload module.

5. Remove four (4) bolts per seam on sections to attach catwalk support braces. Be careful not to push bolts back into channel between the screens. If bolts are accidentally pushed back into the channel when installing the catwalk support brackets, the easiest way to remove them is by creating an extra-long handled wrench. An example of this is shown in [Figure 8P](#). Attach a regular wrench to a long pole, in this case one of the long safety cage bars was used. A crew member can then access the bolt from the channel by reaching in with the extra-long wrench. Carpenter's putty can be placed on the end to help pick up the bolt if needed. The wrench can then be used to hold the bolt in place back in the proper hole as it is re-tightened.



Figure 8P



Figure 8Q

8. Assembling Ladders, Platforms and Catwalks

6. Attach catwalk brackets as shown in [Figure 8R](#).

NOTE: All brackets must attach facing/angling the same direction. In the example, all brackets will face left to match the bracket being installed.

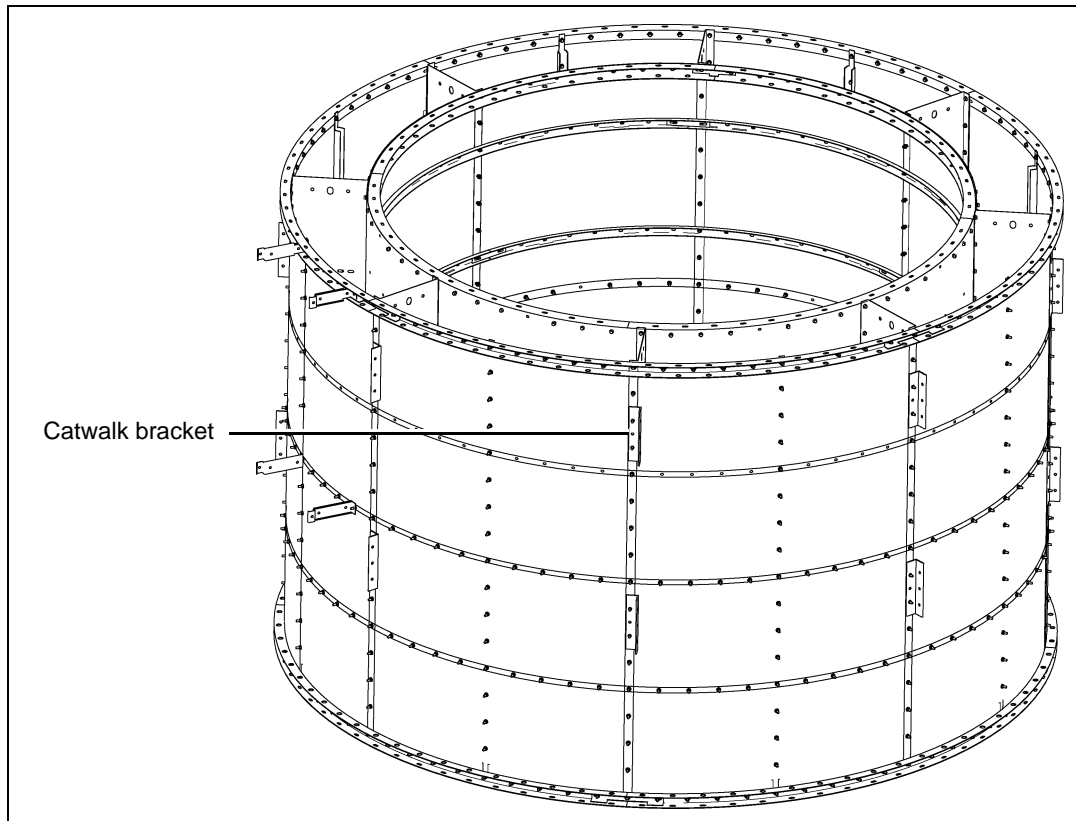

Figure 8R Attaching catwalk bracket to dryer module.

7. Assemble catwalk brace/support braces by connecting as shown in [Figure 8S](#) and [Figure 8T](#) using one nut and one bolt.

IMPORTANT: Finger-tighten only at this time so that the pieces act like a hinge. Place nut to the inside as shown in [Figure 8S](#) and [Figure 8T](#). This helps prevent snagging.

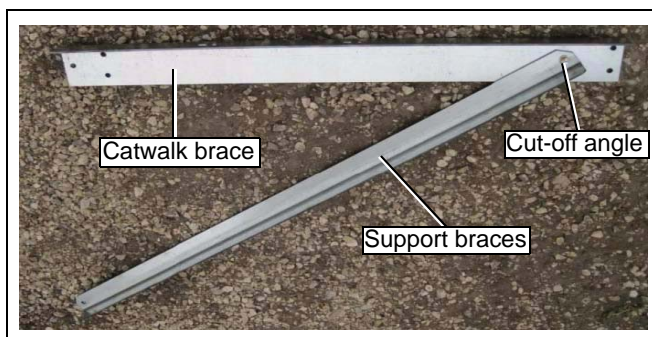

Figure 8S

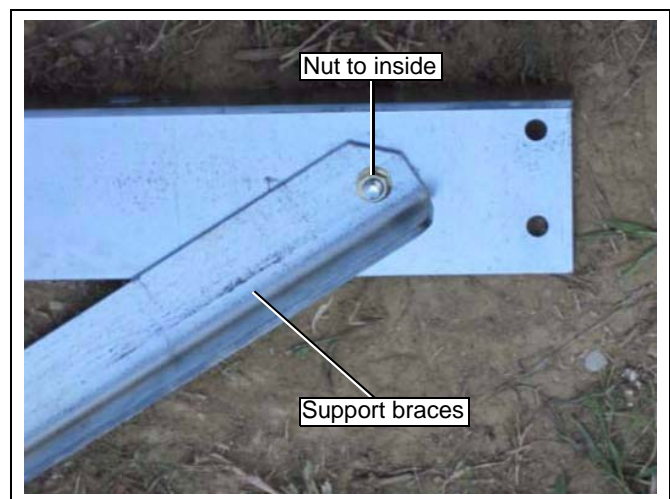

Figure 8T

8. Assembling Ladders, Platforms and Catwalks

8. Attach catwalk brace to dryer wall using the previously installed catwalk brackets. Catwalk brace attach to inside of bracket. (See Figure 8U.) Leave loose.

Lower arm of catwalk brace connects to middle hole of bracket and upper catwalk brace arm connects to middle hole of bracket. (See Figure 8U.)

In Figure 8U, the catwalk brackets all face ←. The catwalk brace attach to the inside of the bracket and the catwalk brace all face ←.

9. Make sure, all catwalk brace should face the same direction.

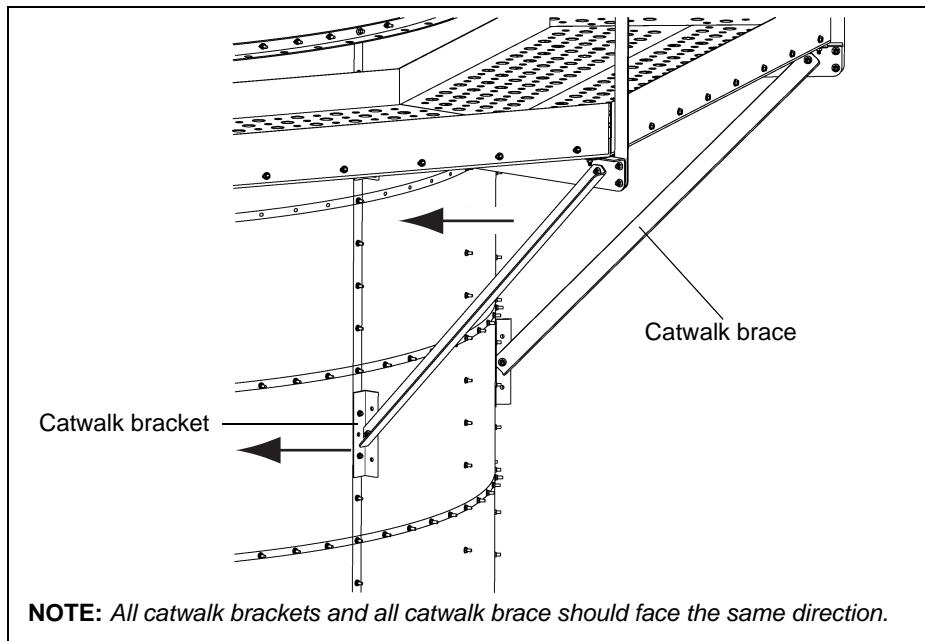

Figure 8U

10. Make sure brackets and/or catwalk brace are NOT installed over the ladder braces as this would block ladder installation. (See Figure 8V.)

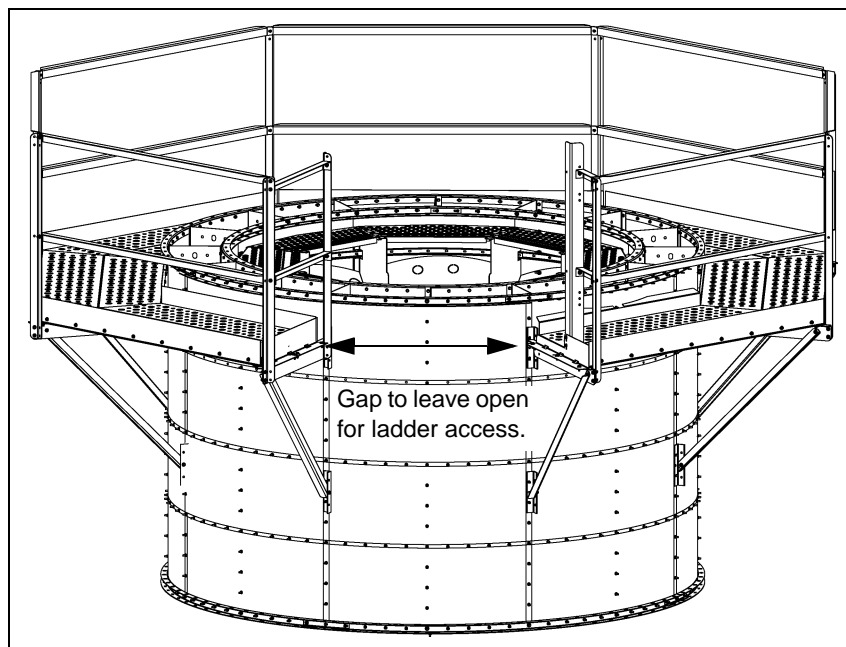

Figure 8V

8. Assembling Ladders, Platforms and Catwalks

11. After attaching the catwalk brace to the catwalk brackets on the dryer wall, attach a catwalk transition to the top of each catwalk brace. (See [Figure 8X](#).)

IMPORTANT: Note the hole alignment on the catwalk transition. The “five (5) hole” pattern near the center of the transition **MUST** be oriented so that the center hole is **AWAY** from the dryer wall. (See [Figure 8W](#) and [Figure 8X](#).)

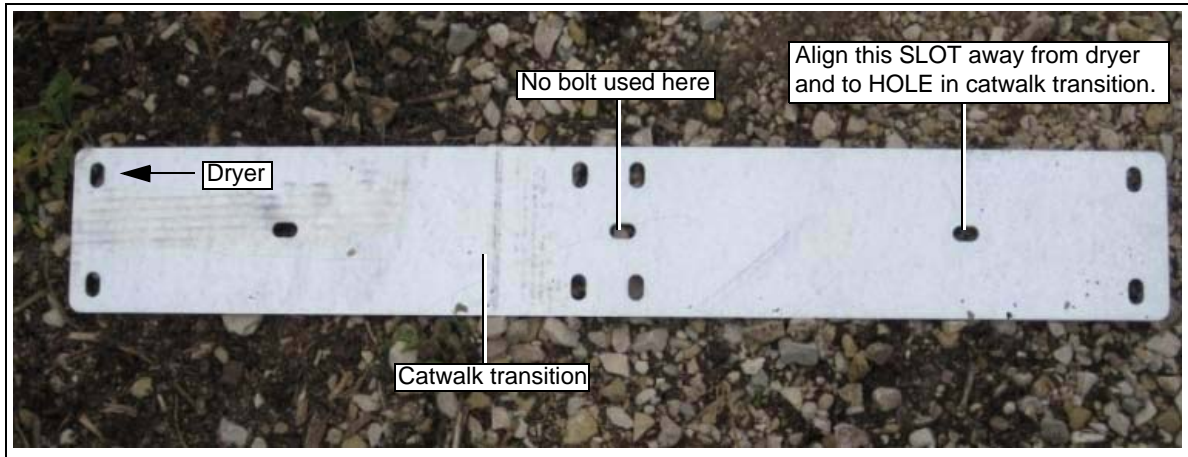

Figure 8W

NOTE: Transition must line up on catwalk brace slot to hole. The SLOT indicated in the [Figure 8W](#) must be oriented away from the dryer wall. Do NOT fill the middle hole of the transition.

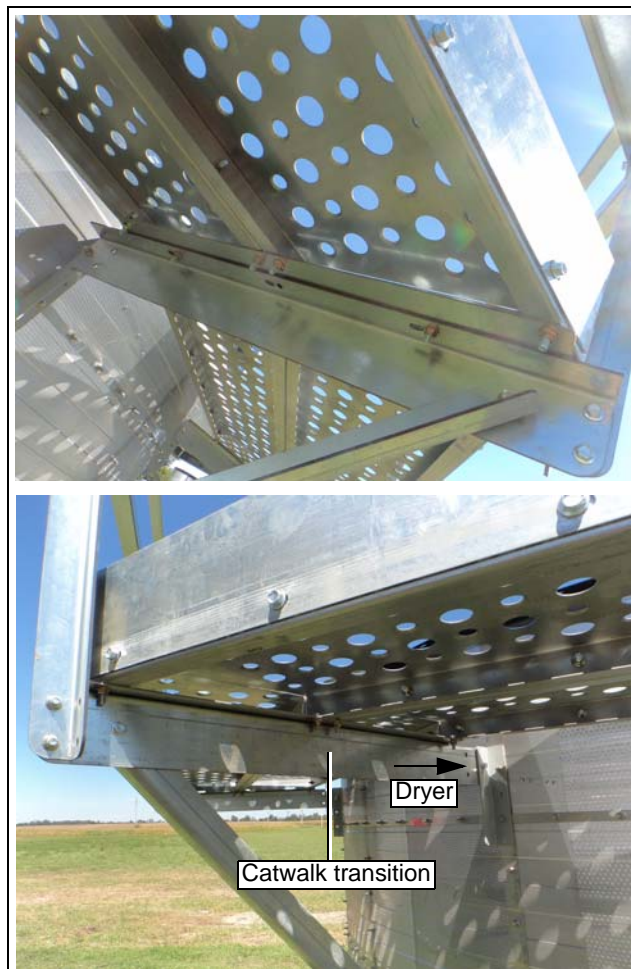

Figure 8X

8. Assembling Ladders, Platforms and Catwalks

12. Attach catwalk planks (with kick plates attached) to catwalk transitions.
13. There are two (2) planks between catwalk brace. The longer plank with the kick plate goes farther away from the dryer wall with the kick plate on the outside and the shorter plank goes closest to the dryer wall with the kick plate to the inside (to prevent stepping or slipping between the plank and the dryer). (See Figure 8Y.)

Use nuts and bolts to connect catwalk planks to catwalk transitions.

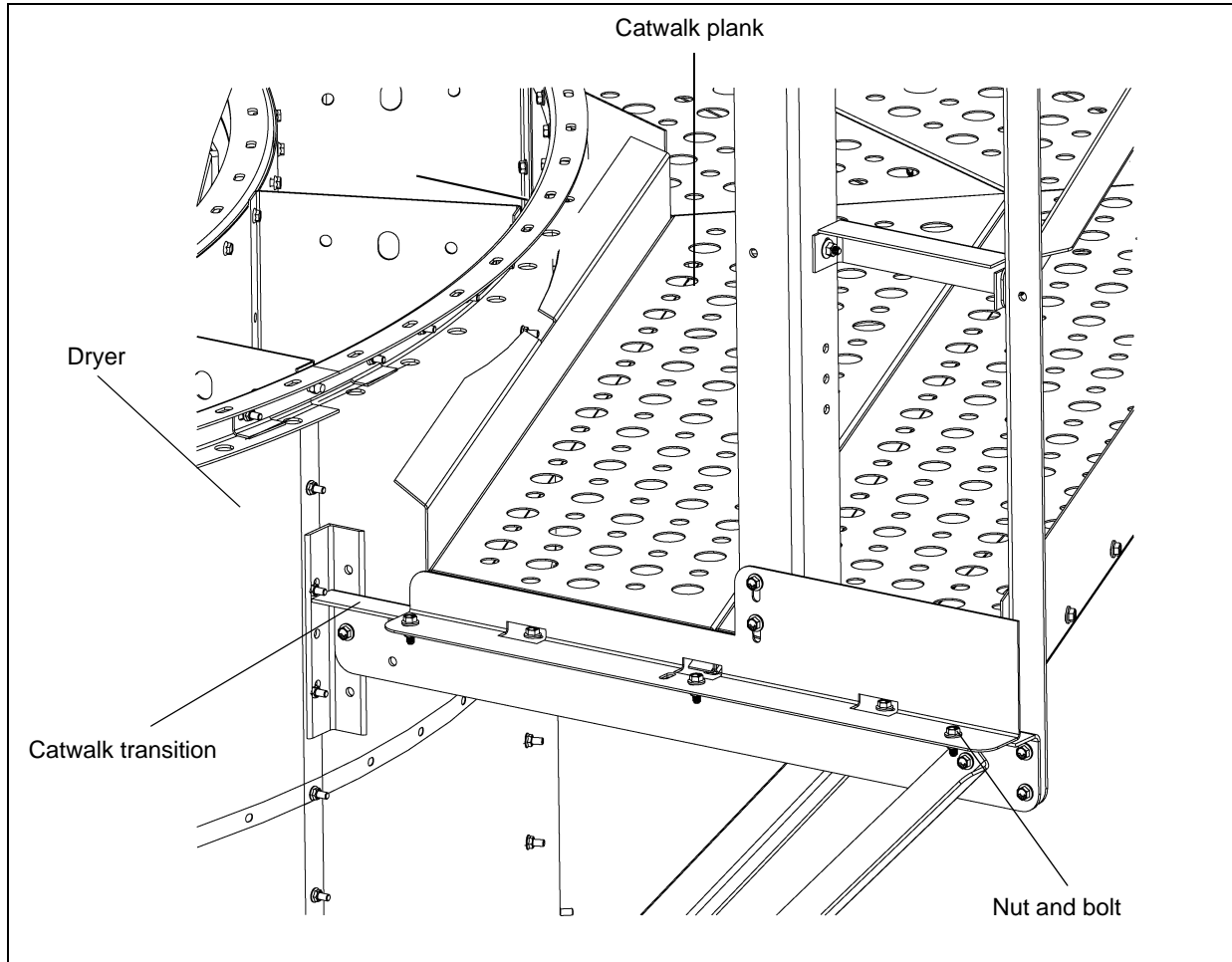

Figure 8Y

8. Assembling Ladders, Platforms and Catwalks

14. Install the catwalk plank with the curved kick plate at the stepover point immediate beside ladders. This is an added safety feature to help prevent feet from being wedged between the catwalk and the dryer wall when stepping over or off a ladder. (See [Figure 8Z.](#)) This is the stepover section immediately beside a ladder. Use ladder brackets for placement guidance.

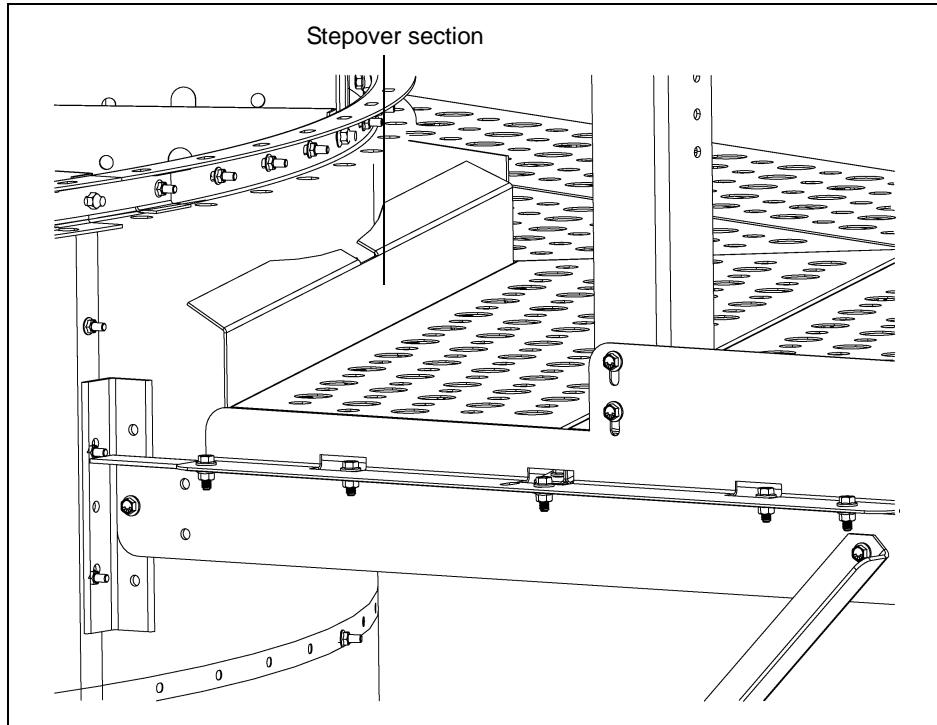

Figure 8Z

15. Stepper kick plates are installed at stepover locations. These kick plates are lower to step-in and higher where the handrail supports attach. (See [Figure 8AA below](#), [Figure 8AB](#) and [Figure 8AC on Page 47.](#))



Figure 8AA

8. Assembling Ladders, Platforms and Catwalks

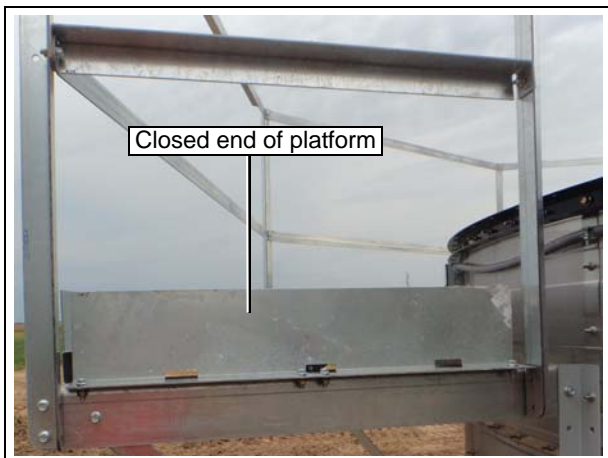

Figure 8AB

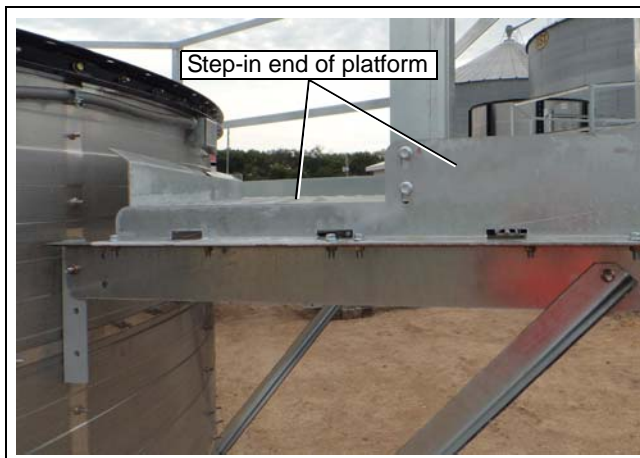

Figure 8AC

16. Attach handrail supports to catwalk brace as shown in [Figure 8AD](#) and [Figure 8AE](#).
17. Attach handrails to handrail supports as shown in [Figure 8AD](#) and [Figure 8AE](#). Make sure curved side of handrails is to the inside for use. The sharper flat sides should be to the outside.



Figure 8AD



Figure 8AE

8. Assembling Ladders, Platforms and Catwalks

18. Connect handrails to the inside of supports as shown in *Figure 8AF*. Nuts should be to the outside and the curved side of the handrail should be to the inside of the platform or catwalk for use. (*See Figure 8AF.*) Note handrail orientation. Flat side goes to the outside away from the dryer. Rounded side goes to the inside for hand safety. Outside away from the dryer. (*See Figure 8AF.*) Also note the placement of connecting handrails to handrail support.



Figure 8AF

19. When assembling catwalks and platforms be sure to leave open the area between seams where ladder brackets are located. Ladders will be installed at these points to connect the platforms and catwalks.
20. Attach ladder to roof module at this time, BEFORE lifting roof to be connected to other modules.
21. Do not attach other ladders at this time. Ladders for all other modules below the roof module will be attached AFTER the roof module and/or other modules are lifted and placed.
22. Tighten all hardware.

Overview for Safety

Before lifting any modules make sure the lifting capacity of the crane is adequate for the total combined weight of the module or modules, as well as any attached accessories such as catwalks, platforms and ladders.

- Roof = 2200 lbs.
- Turner = 2550 lbs.
- Heat = 1450 lbs.
- TM-1008 Blower section = 4000 lbs.
- TM-1010 Blower section = 4100 lbs.
- TM-1012 Blower section = 4200 lbs.
- TM-1015 Blower section = 4500 lbs.
- Unload = 6250 lbs.
- Heat section with 15 channels = 1675 lbs. (3rd Module on every dryer.)
- Catwalks = 1140 lbs.

NOTE: Section weights do NOT include the additional weight of the catwalk that will be attached to the appropriate section(s). Catwalk weight is approximately 1140 lbs.

The GSI Modular Tower Dryer is designed for quick and safe on-site installation. In order to maximize safety, always perform as much work as possible as close to the ground as possible. Use the illustration guides included later in this section for reference.

All sections of the GSI Modular Tower Dryer come labeled by the factory. Separate labels identify the dryer sections by name and by their sequential placement in the overall stacking of the Modular Tower Dryer.

To determine the weight of multiple sections when lifting them together, simply add the section weights together and if applicable, add the weight of the catwalk as well.

NOTE: It is recommended to attach ladder to roof module BEFORE lifting roof off of ground. Attach ladder to section below roof module AFTER roof module is placed upon it.

NOTE: 8' Ladder section will only be able to be attached after the section is stacked on another section.

Venturi

Make sure venturi is inside unload section or pre-installed before stacking burner/blower on unload.

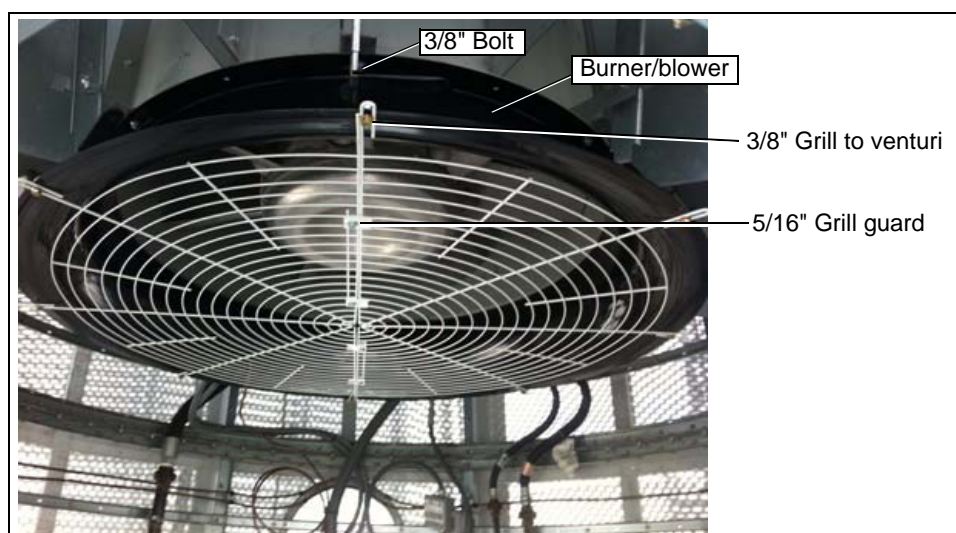

Figure 9A

9. Lifting and Stacking the Modules

The GSI Modular Tower Dryer is designed to maximize safety and minimize assembly time. All models will be assembled in similar fashion by: Lifting the roof module, stacking it on to the dryer module to be directly underneath it and connecting those modules together. Then, the conjoined modules are lifted and stacked on the next highest dryer module and connecting the modules. In this way, the vast majority of work will be completed no more than ten feet (10') off of the ground. See the following figures on [Pages 50-53](#) for the specific recommendations for each model of the GSI Modular Tower Dryer.

NOTE: In all instances, six feet (6') lifting straps are recommended.

Recommended Stacking Order: Model 800 Series Dryer

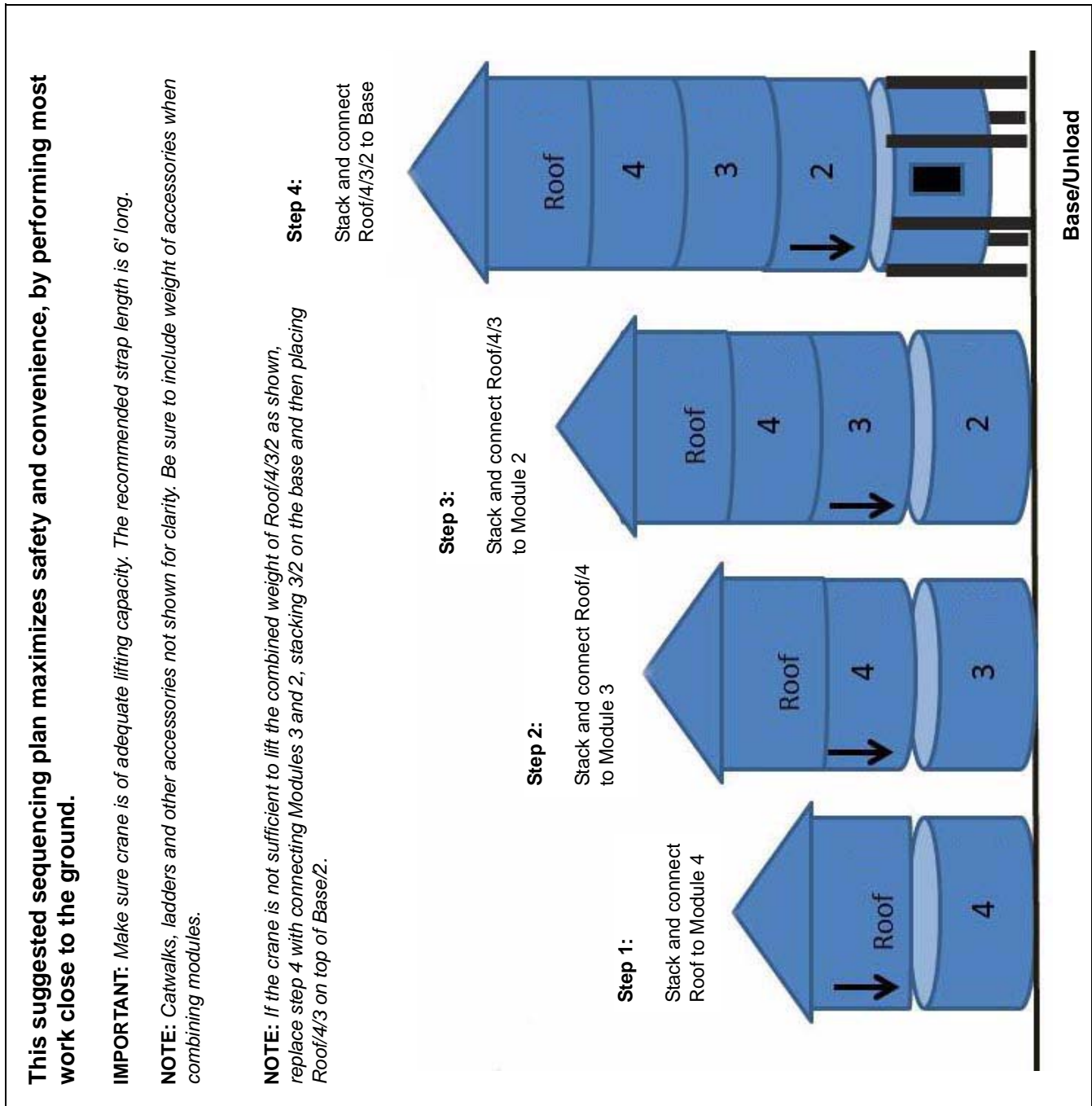

Figure 9B Model 800

Recommended Stacking Order: Model 1010 Series Dryer

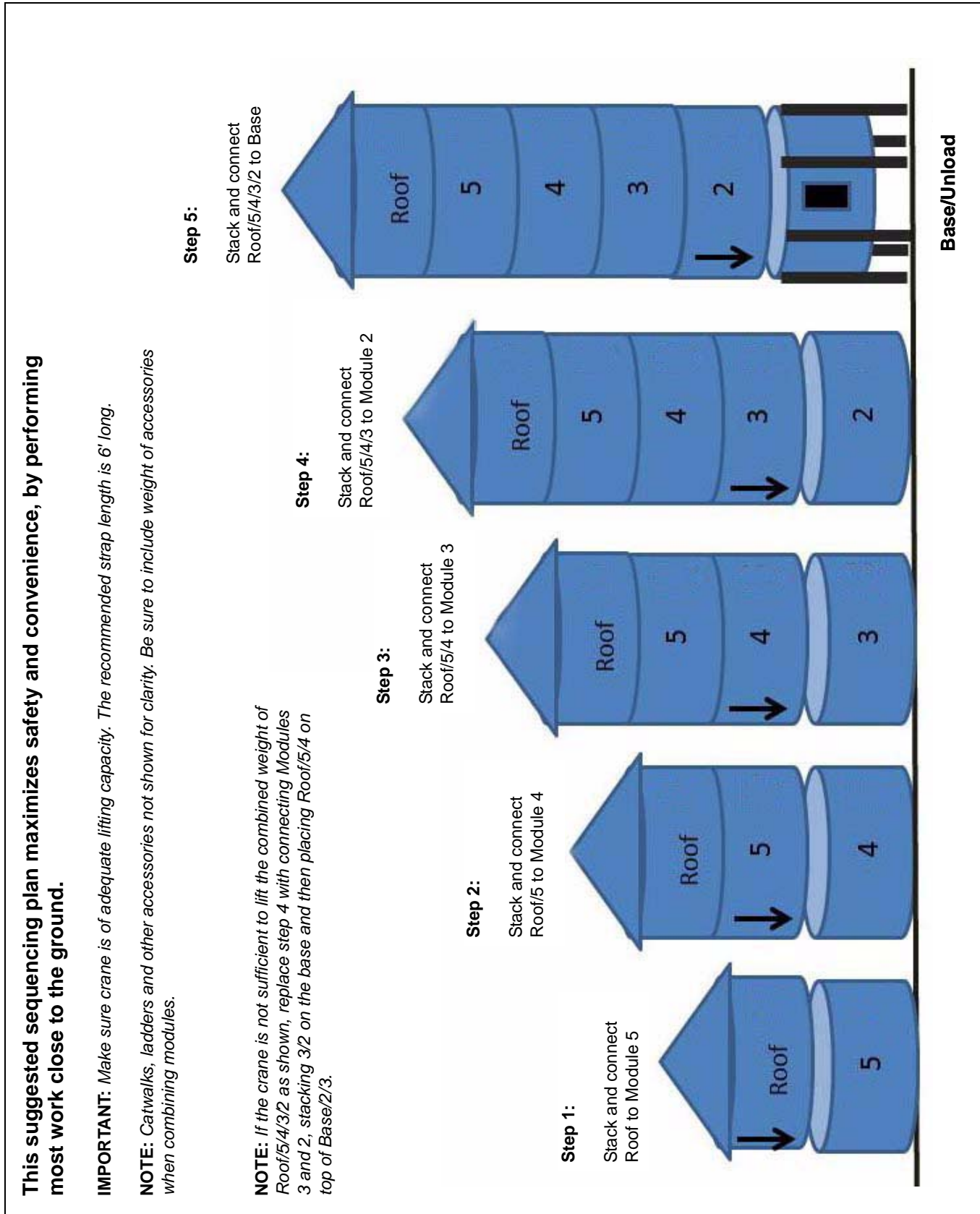

Figure 9C Model 1010

Recommended Stacking Order: Model 1200 Series Dryer

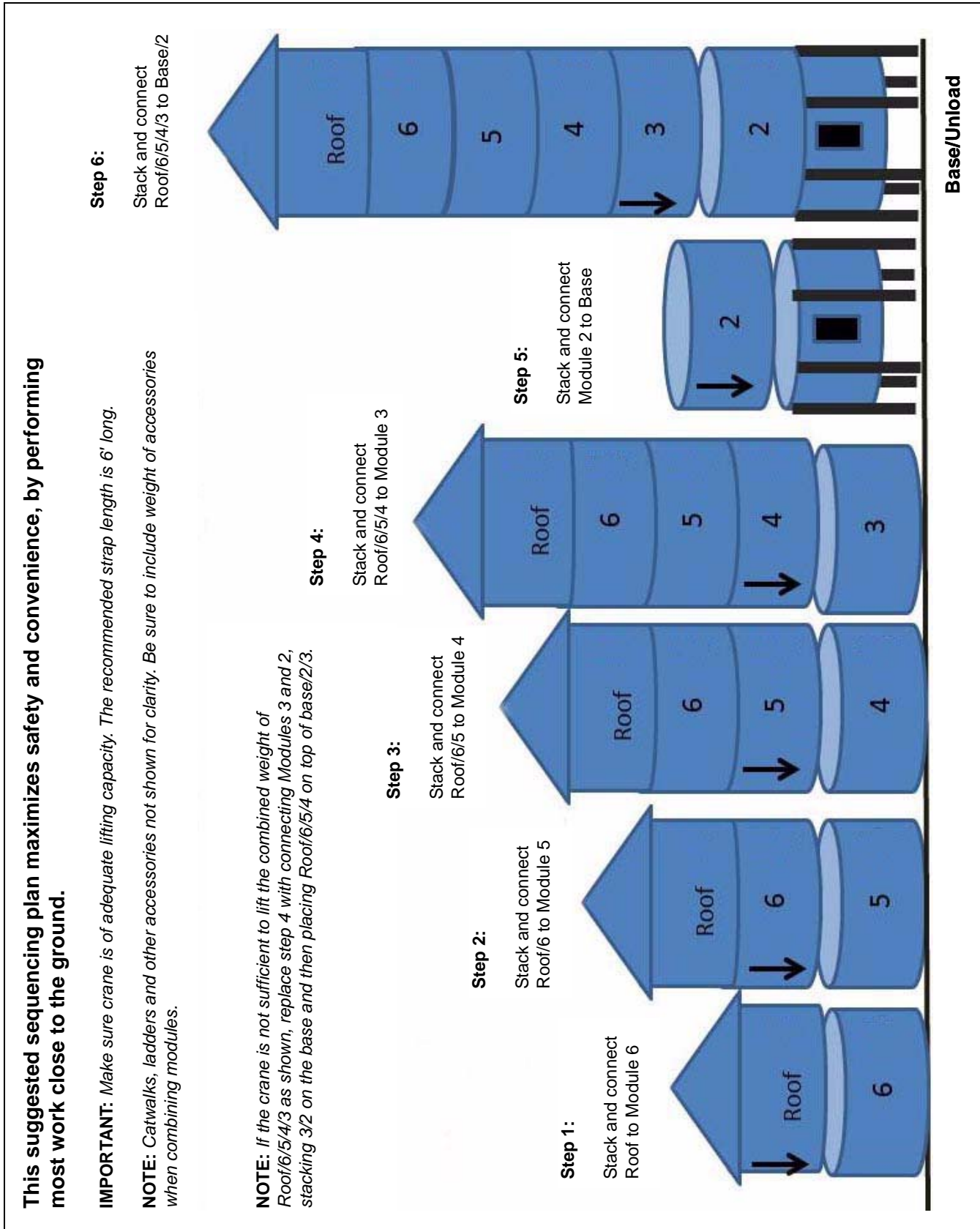

Figure 9D Model 1200

Recommended Stacking Order: Model 1500 Series Dryer

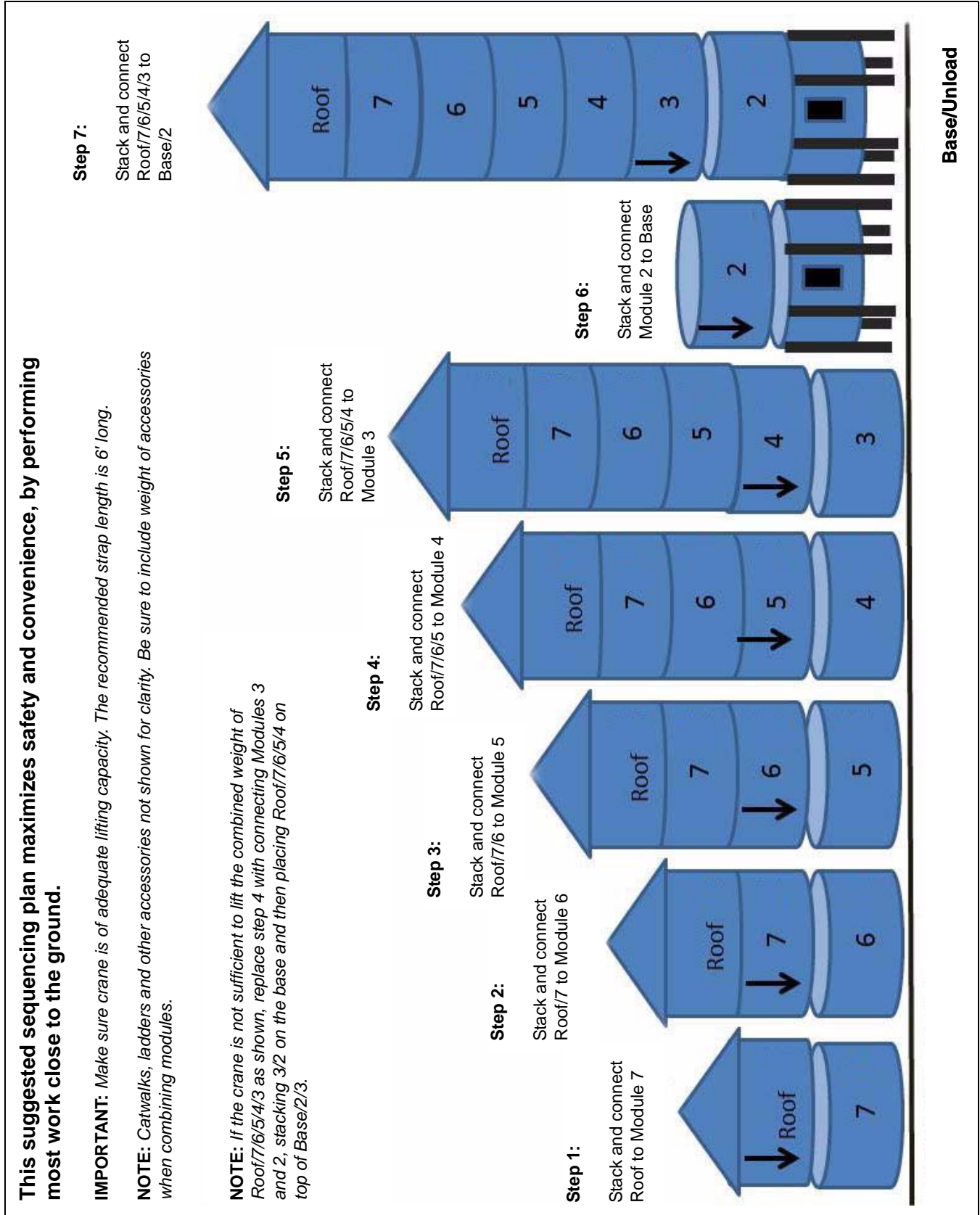

Figure 9E Model 1500

9. Lifting and Stacking the Modules

Lifting



Lifting hazard. Use all personnel protective equipment during lifting.

1. Use four (4) clevis hooks to connect the crane's lifting straps to the module.
2. Remember, all modules except the roof, lift from four (4) equally spaced holes located in the channels. (See [Figure 9G.](#))

NOTE: The recommended strap length for lifting is 6' long.



Figure 9F



Figure 9G



Figure 9H

9. Lifting and Stacking the Modules

3. When maneuvering lifted modules across open ground, have personnel beside it to guide it and minimize sway. When lifting the module on top of another module, be sure personnel have hard hats.
4. Carefully lower the module so that the connecting channels of each module are touching and can be connected with nuts and bolts, however, do NOT lower fully at this time.

DO NOT REST THE UPPER MODULE(S) ON THE LOWER MODULE(S) AT THIS TIME. KEEP SOME DEGREE OF TENSION ON THE MODULE FROM THE CRANE. ONLY FULLY LOWER THE UPPER MODULE(S) ONCE ALL ARE MADE AT THE CONNECTING CHANNELS WITH NUTS AND BOLTS.

Connecting Modules

5. Use the punches to line up connecting holes so that nuts and bolts can be loosely inserted at this time.

NOTE: *Significant hammering and prying to accomplish hole alignment is to be expected.*



Figure 9I



Figure 9J

NOTE: *Ideally, crews will work in two (2) person teams with one team working inside the dryer and one team working outside the dryer. Each person should have at least two (2) punches with narrow pointed tips and long enough to provide significant leverage. Place step ladders and tools INSIDE modules before stacking for ease of access.*

9. Lifting and Stacking the Modules

6. When stacking one module on top of another, be sure to line up ladder brackets.

In [Figure 9K](#), ladder brackets are circled.



Figure 9K

7. Installation should proceed with a team of two (2) working to connect the modules from inside of the dryer and two (2) working to connect the modules on the outside of the module.

For ease of assembly, place all tools, hardware, caulk and step ladders inside the module before stacking another module on top of it.

[Figure 9L](#) shows a team of two (2) working to connect the modules on the inside.

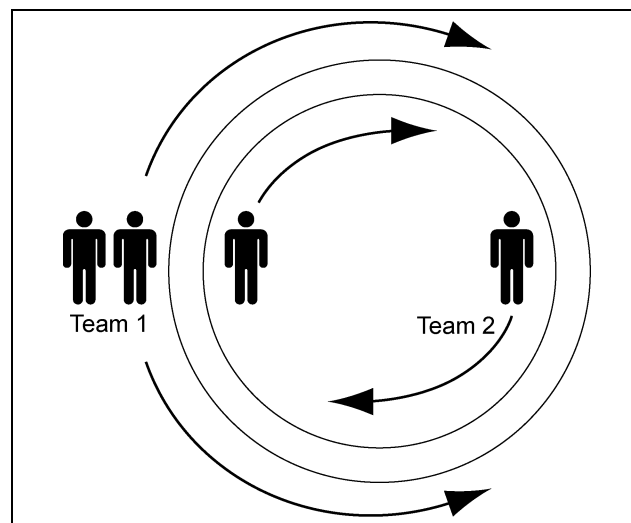

Figure 9L

NOTE: Caulk any gaps as the teams work around the modules. As it will be very difficult to do after the unit is built.

9. Lifting and Stacking the Modules

8. On all models of the GSI Modular Tower Dryer, the first two (2) connecting seams - between the base/unload module and Module 2 and between Module 2 and Module 3 - require a nut and bolt in EVERY hole of the connecting channel, both INSIDE and OUTSIDE of the dryer.

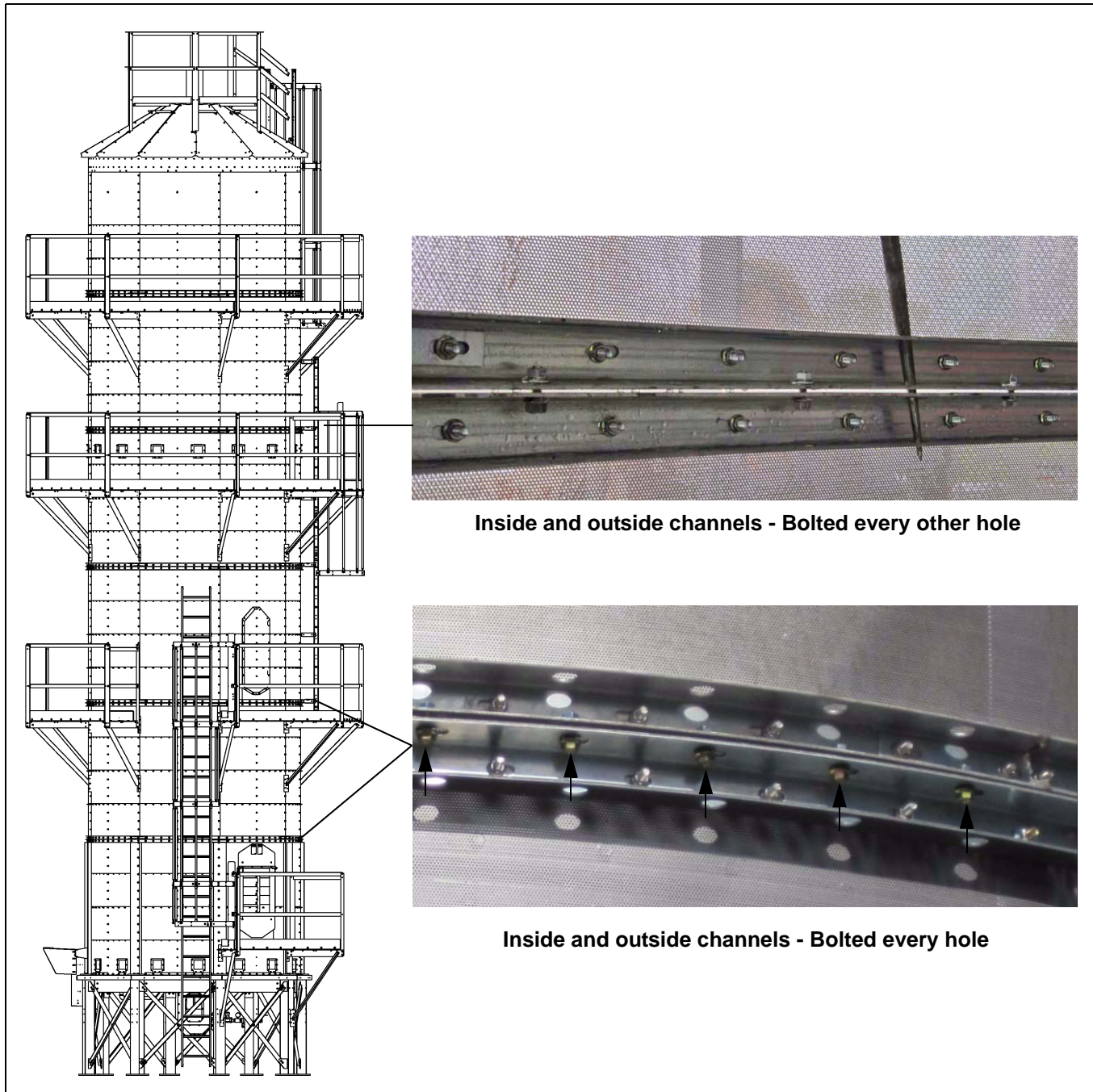

Figure 9M

- a. For all other connecting seam after/above the first two (2), every other hole may be bolted.

9. Lifting and Stacking the Modules

9. Once all holes (or every other hole based upon which seam of the dryer you are working on at the time) have a nut and bolt installed and are finger tightened, tighten with an electric impact: torque to 45 ft./lbs.

NOTE: When installing, in all possible situations, place the impact on the bolt. Do NOT tighten the nut as it will not lock down on the ring. Always tighten the bolt. (See Figure 90.)

NOTE: Accessing the bolts that connect sections of the dryer together requires passing through the hole in the channel as shown. Narrow 3/8" drive sockets and/or extensions are required. (See Figure 9N.)



All cordless impacts are NOT recommended for installation as they will not sufficiently torque the bolts. Use electric impact and torque to 45 ft./lbs. If bolts are not torqued properly, channels will compress when filled and bolts will become loose.



Figure 9N Connecting Dryer Sections on Outside

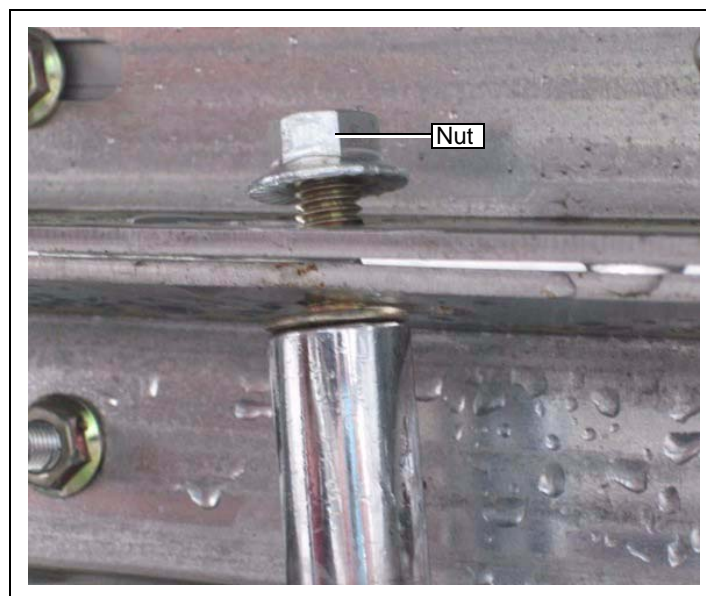

Figure 9O Always tighten the bolt, not the nut to achieve torque specifications.

9. Lifting and Stacking the Modules

10. To stack additional sections, repeat the process as described - always remember to line up the ladder brackets on the modules -- and follow the suggested sequence illustrated earlier in this chapter.
- Consider the orientation of each module as it pertains to ladders and catwalks before placing it on the module for connection.
 - Secure the module with clevis hooks and lifting straps. Lift with crane and place on top of next module.
 - Place section together but do not fully rest upper section on lower section.
 - Use hammers and punches to line up connecting holes in channels both inside and outside of dryer.
 - Insert nut and bolt and finger tighten in every hole or every other hole as appropriate.
 - Tighten with power impact.



Caulk gaps with clear food-grade silicone as needed.

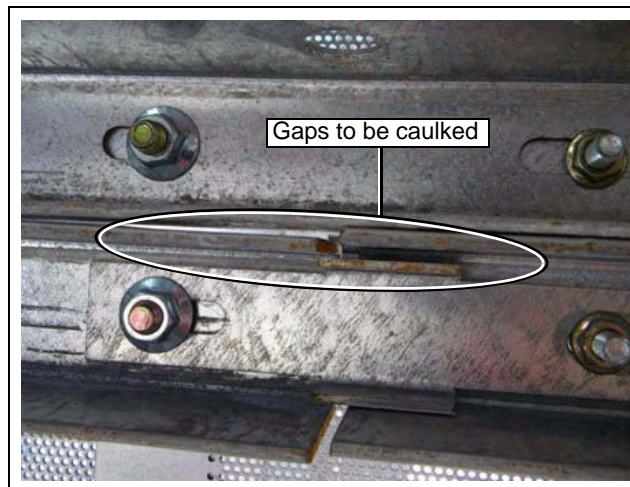

Figure 9P *Gap Un-Caulked*

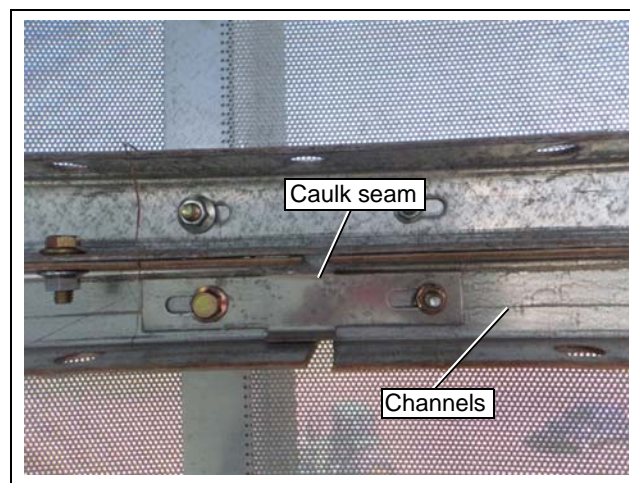

Figure 9Q *Gap Caulked*

NOTE: *ALWAYS stack and connect so that as much work as possible is done as close to the ground as possible. Use the illustrations at the beginning of this chapter as a guide to accomplish this.*

IMPORTANT: *It must silicone any gaps to prevent leaks.*

9. Lifting and Stacking the Modules



Figure 9R

NOTE: It is normal for “dents” or “wrinkles” to appear in the screen during this process of stacking and connecting. Most “dents” and/or “wrinkles” will be eliminated or greatly reduced in the final step of the installation process.

Stiffener Splice

Place stiffener splice plate over stiffener at joint of section 1 (base/unload section) and section 2 (burner/blower section).

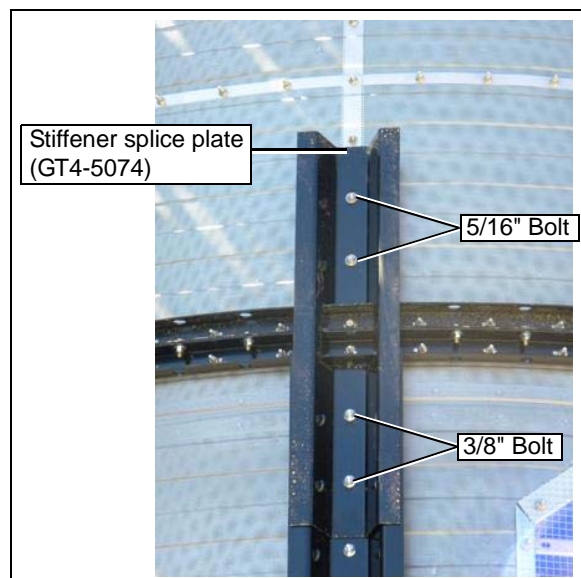

Figure 9S TM-1015

NOTE: Seal the upper bolts 5/16" with e-clip. To avoid drop into the dryer while placing stiffener splice.

Electrical Overview Minimal Connections

One of the most beneficial features of GSI Module Tower Dryers is the fact that much of the electrical wiring is done at the plant prior to shipping. This is an advantage for the customer as fewer electrical connections need to be made in field, thereby making is a quicker and safer installation. The connections to be made in the field by the customer are:

- Air switch
- Flame sensor and ignitor wires (spark plug)
- Bindicator, outside overheat and moisture sensor
- Plenum temperature
- Gas pipe train (natural or LP) overview minimal connections

Adjustable overheat honeywell thermostat capillary is ran up to burner section.

These connections are reviewed in greater detail this section.

Another advantage of the GSI Modular Tower Dryer is the ability of the vision control box to be remote mounted. The control box can remain on the unload module as shown and shipped or if the customer prefers, it can be remote mounted in a more convenient location for user access or to allow auxiliary equipment access to the tower dryer.

If the vision control panel remains mounted on the unload module of the GSI Modular Tower Dryer, the protective rain shield should be installed as shown in [Figure 10A](#) to help protect it from the elements.



Figure 10A

Air Switch

1. The air flow sensor connects to the grill guard on the fan with a rubber grommet and feeds through to a connecting point on the outside of the electrical control box, which connects to the sensor on the inside of the control box. (See [Figure 10B](#), [Figure 10C](#) below and [Figure 10D](#) on Page 63.)

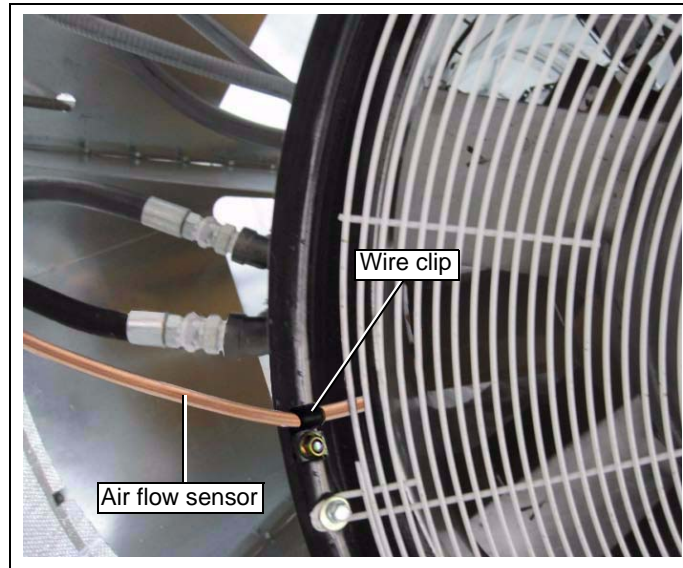

Figure 10B

2. Connect the air flow sensor (copper tubing) from the grill guard inside of dryer burner/blower to the rubber grommet on the side of the outside control box. (See [Figure 10C](#).)

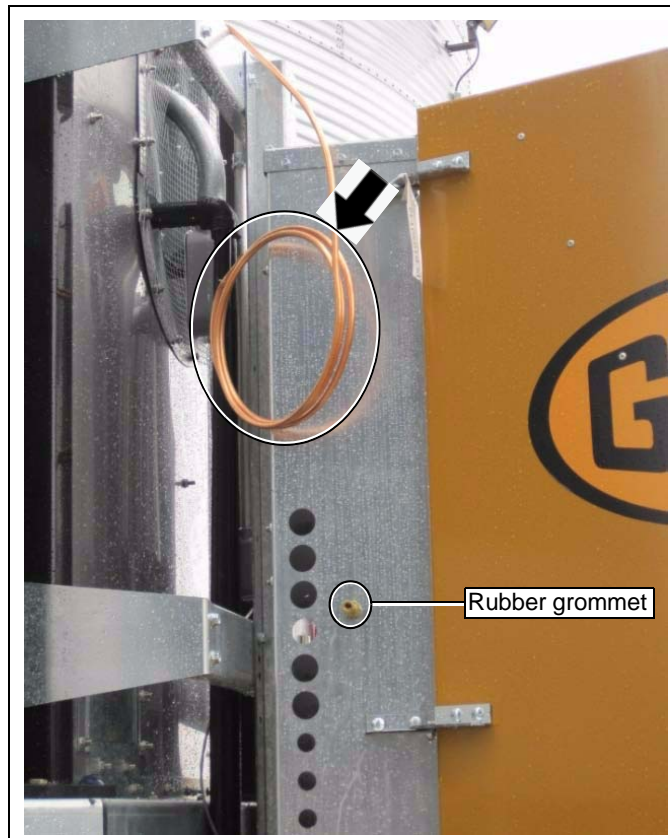

Figure 10C

3. The rubber grommet connects to the air flow sensor inside of the control box. (See Figure 10D.)

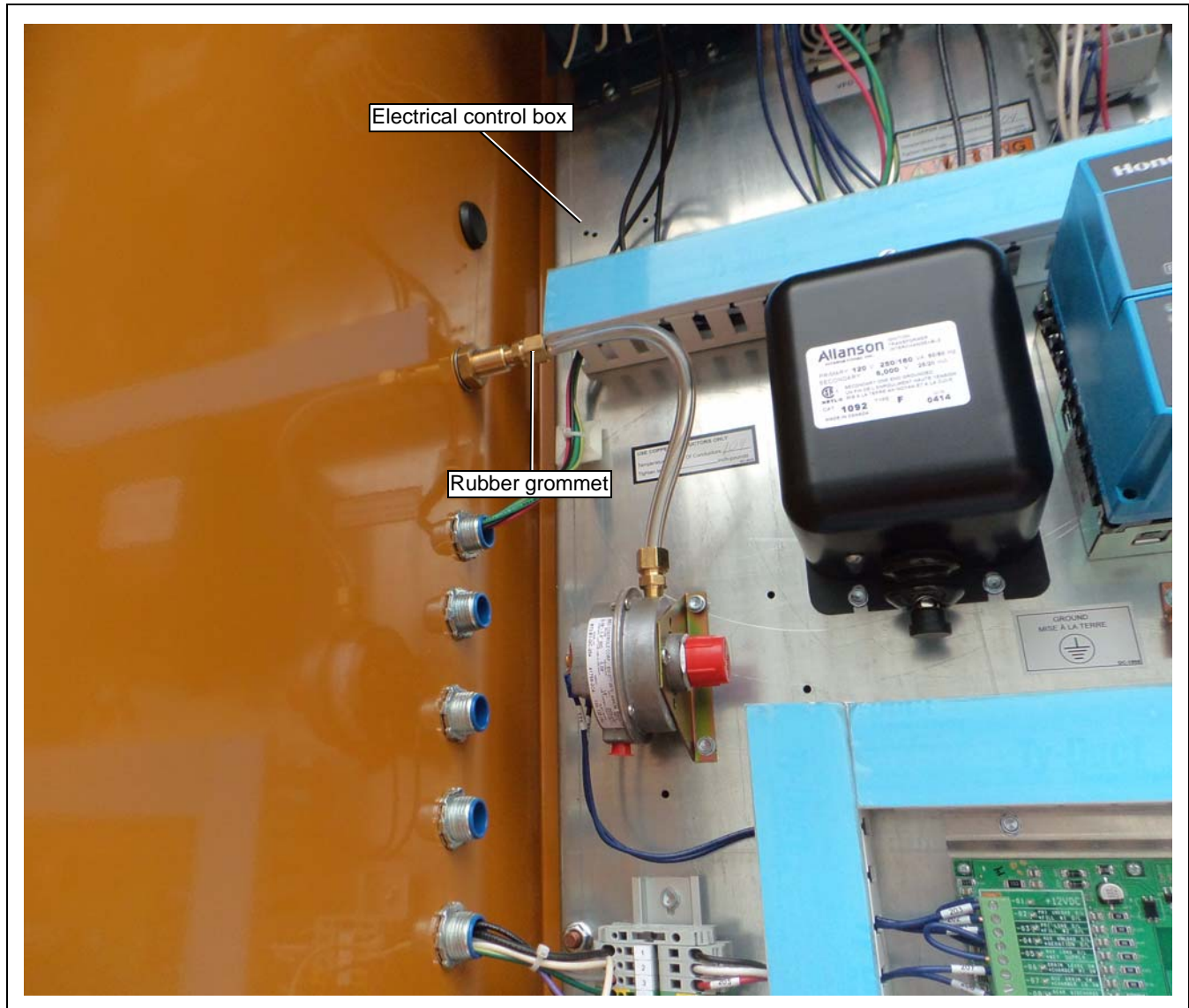

Figure 10D

Flame Sensor and Ignitor Wires (Spark Plug)

1. From inside the burner/blower module, the flame rod wire and the spark plug wire will be passed through these holes as shown in [Figure 10F](#).
2. The flame sensor and ignitor wires connect to the electrical control box.

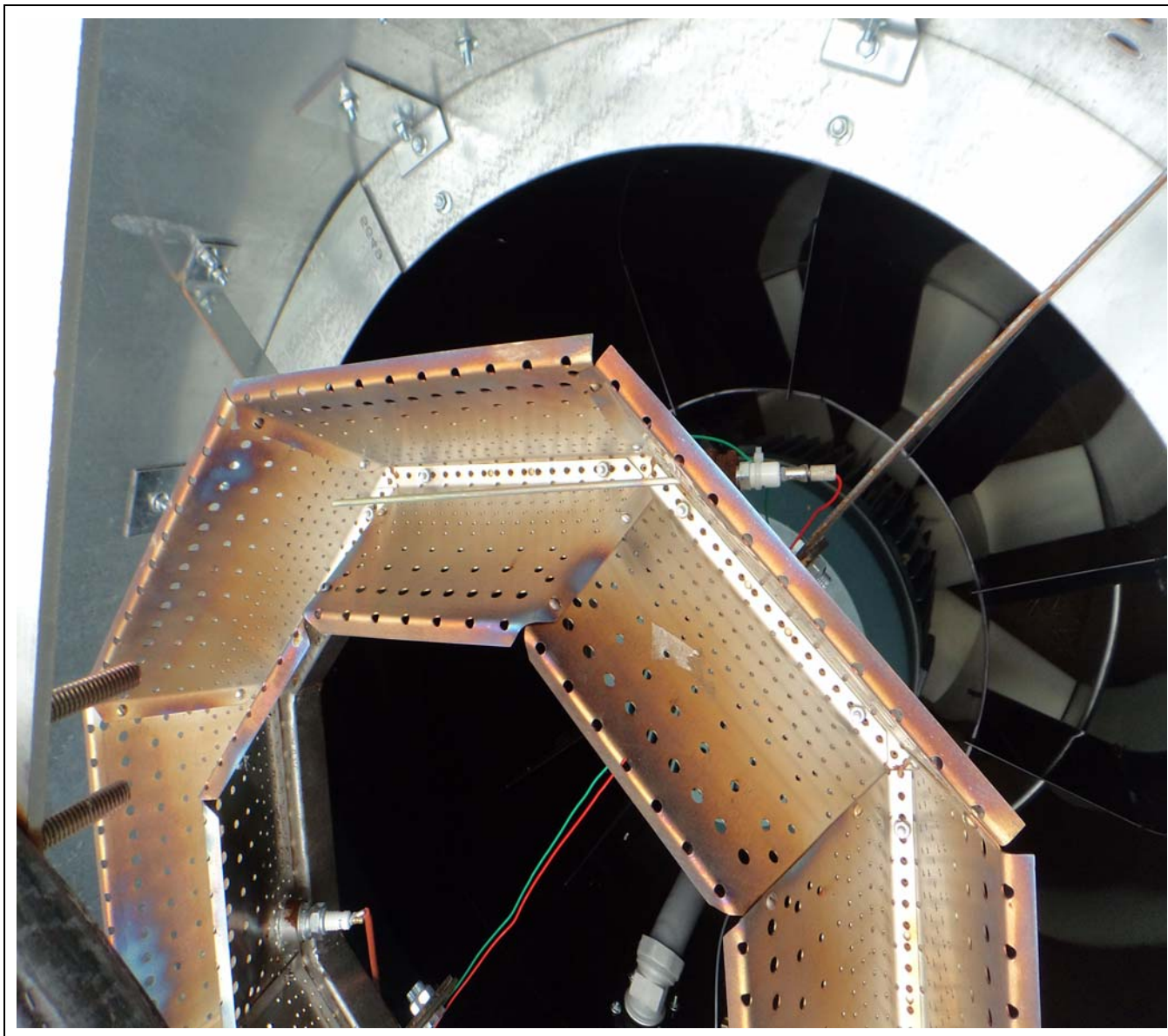

Figure 10E

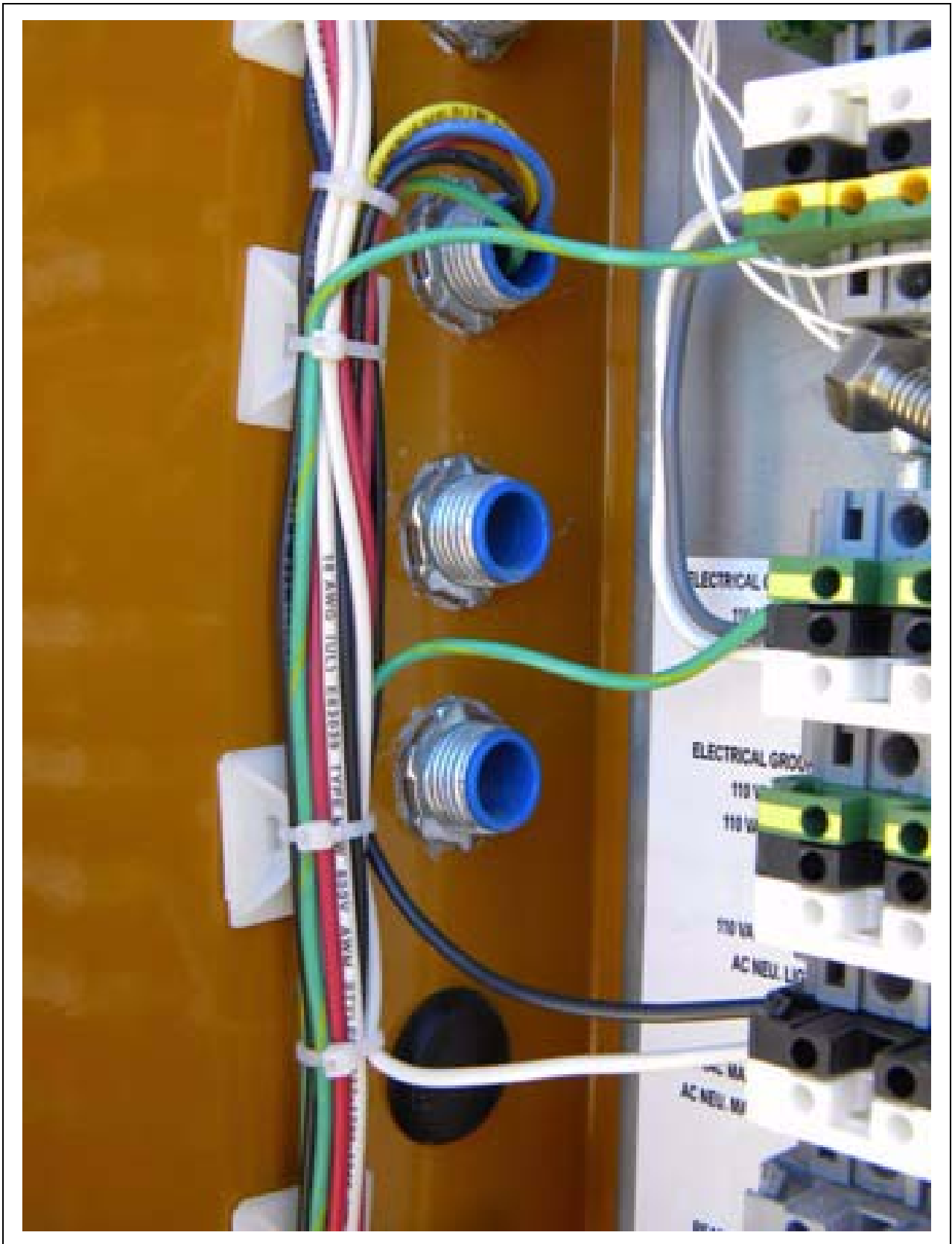

Figure 10F

Bindicator, Outside Overheat and Moisture Sensor

The bindicator is mounted on the roof with its wiring running the height of the dryer in sealtite and is connected by the customer in the field. (See [Figure 10G.](#))

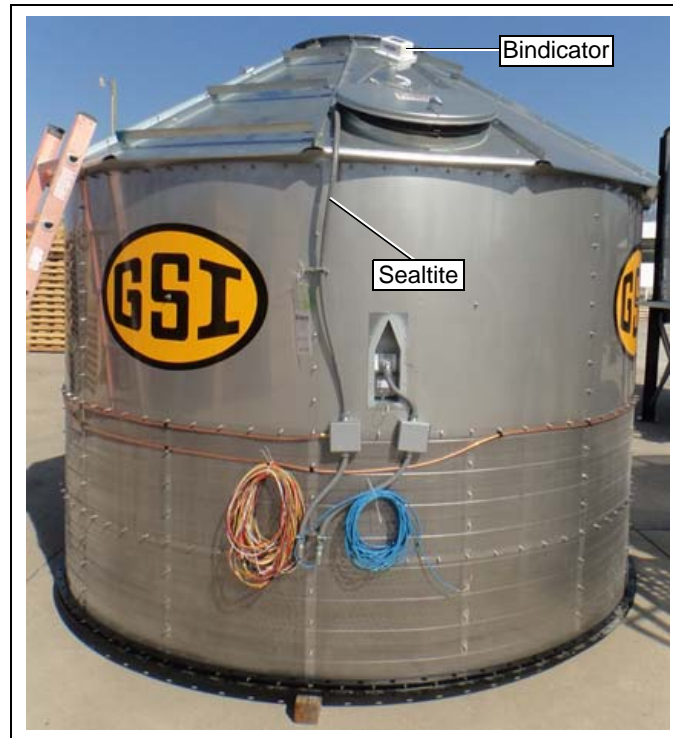

Figure 10G

The outside overheat (copper tubing) runs the circumference of the dryer on the roof module. It connects to a junction box with conduit running the height of the dryer and is connected to the control panel by the customer in the field. (See [Figure 10H.](#))

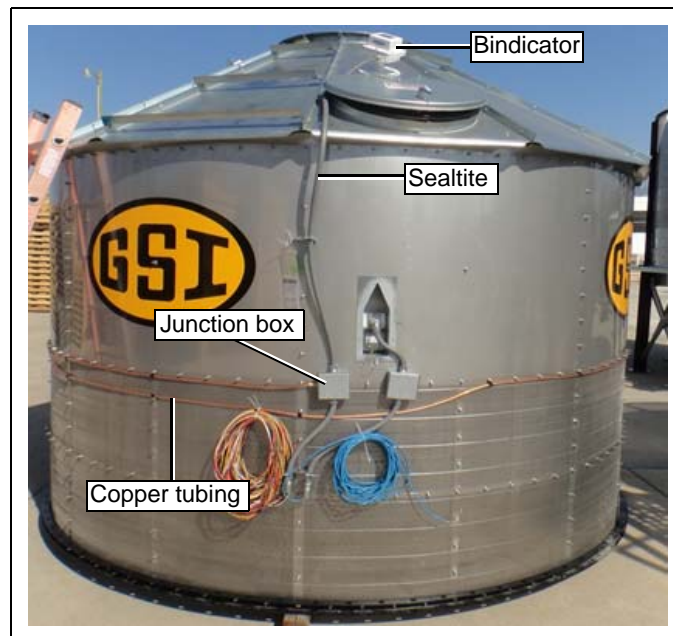

Figure 10H

Plenum Temperature

Plenum temperature is monitored through the wiring in the conduit that runs up through the burner/blower floor. This was referenced in burner/blower module on [Page 48](#), when installing the floor planks in the burner/blower module as it was necessary to cut a floor plank to fit around the conduit.

Connecting this is also done in the field by the customer. ([See Figure 10I.](#))



Figure 10I

After installing the conduit clamps, simply route the conduit through the clamps and close them. ([See Figure 10J.](#))

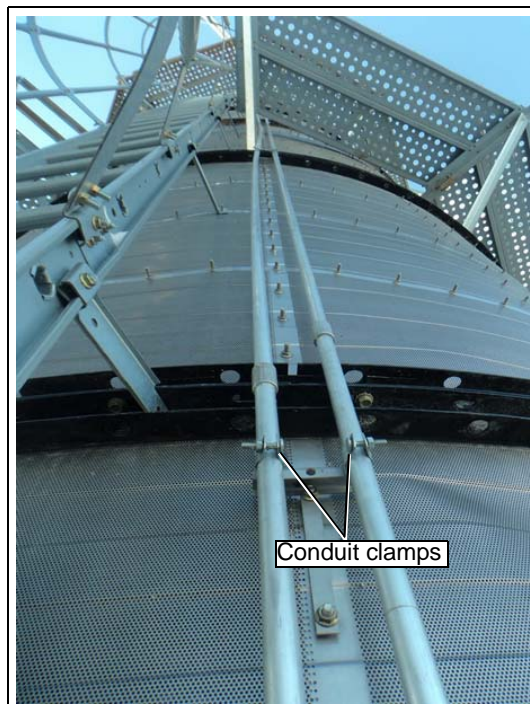

Figure 10J

11. Gas Pipe Train Overview

Gas Pipe Train (Natural or LP) Overview Minimal Connections

Another beneficial feature of the GSI Modular Tower Dryer is the fact that the gas pipe train comes pre-fitted and pre-assembled from the factory. This minimizes the connections that need to be made in the field. The result, is a quicker and simpler installation process.

Only three (3) connections need to be made in the field to complete the gas train. (*See Figure 11B.*)



Figure 11A

The three (3) connecting hoses for the gas train are for:

- Liquid in
- Vapor out
- Return to burner

All three (3) are shown in the *Figure 11A* and ship in the crate along with catwalks, platforms and other hardware.

Each hose has unique fittings and can only be installed in the proper location.



Figure 11B

1. The largest connecting hose connects inside the dryer for the return to blower. (See Figure 11C.)

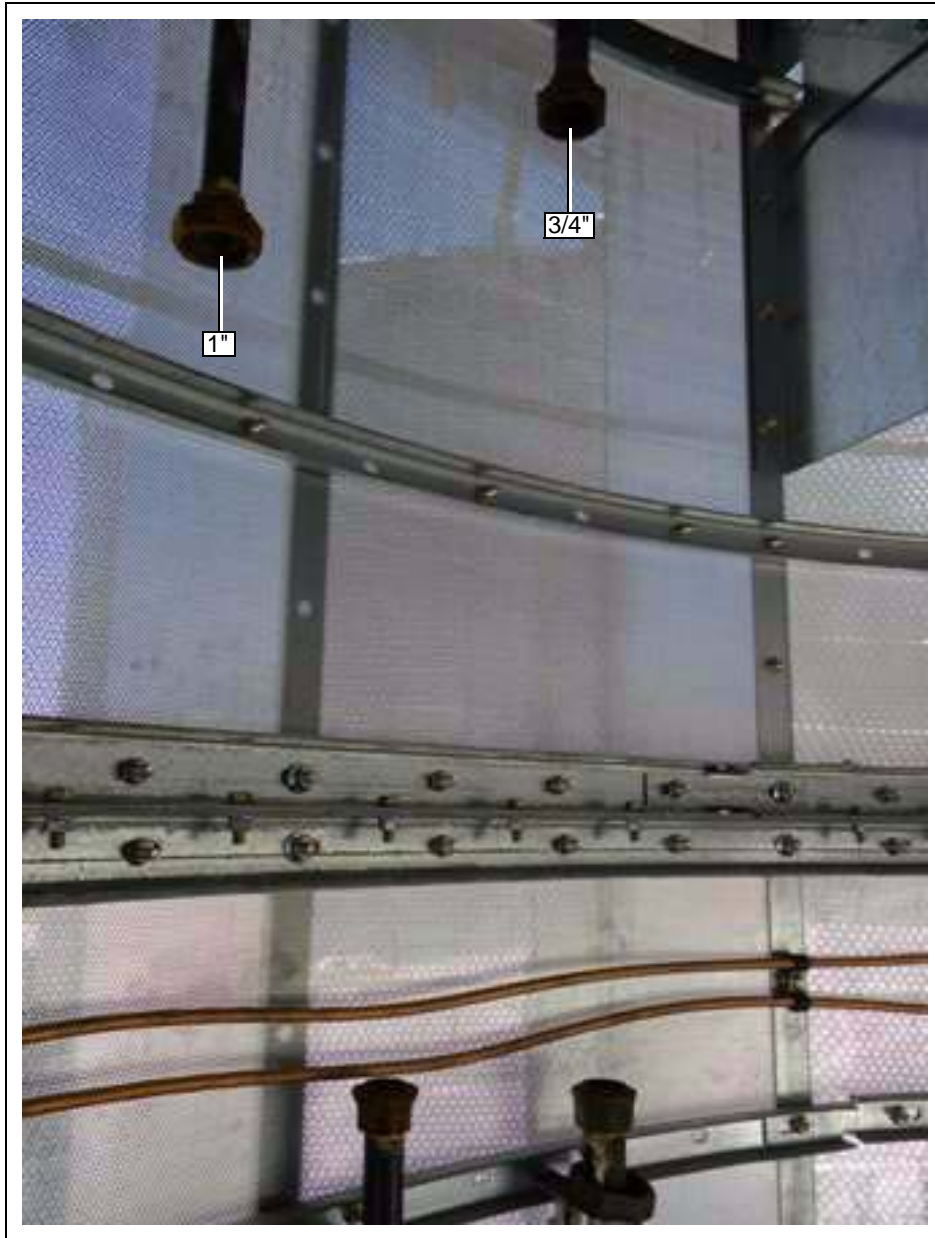

Figure 11C

2. The remaining two (2) connecting hoses are installed inside the dryer as shown.

NOTE: All three (3) connecting hoses are pre-sized for correct connections and cannot be connected in the wrong location as a result.

12. Finishing Touches: Removing Wrinkles and Dents from Screens

During the installation process it is common for screen to “dent” or “wrinkle” from the pressures and stresses of assembling. Examples of “denting” and “wrinkling” in the screens are circled in the [Figure 12A](#). They are often most visible in bright, reflective sunlight. Removing (or greatly minimizing) these dents and wrinkles is one of the final steps in the installation process. When removing wrinkles, work from the top down.

1. Using all proper safety equipment and precautions, crew members should loosen the nuts on the nearest columns one at a time until the “dent/wrinkle” literally “pops” out. Then, the nut(s) can be re-tightened.

In [Figure 12A](#), the columns in which the nuts should be loosened are between the arrow marks.

NOTE: In [Figure 12A](#), the circles area highlights the wrinkle or dent in the dryer screen. The boxes indicate the seams on which the nuts/bolts should be loosened to “pop” it out. Re-tighten after the sheet has been “popped” back out. DO NOT loosen nuts that connect the modules together.

NOTE: New dryers ship with corrugated sheets.



Figure 12A

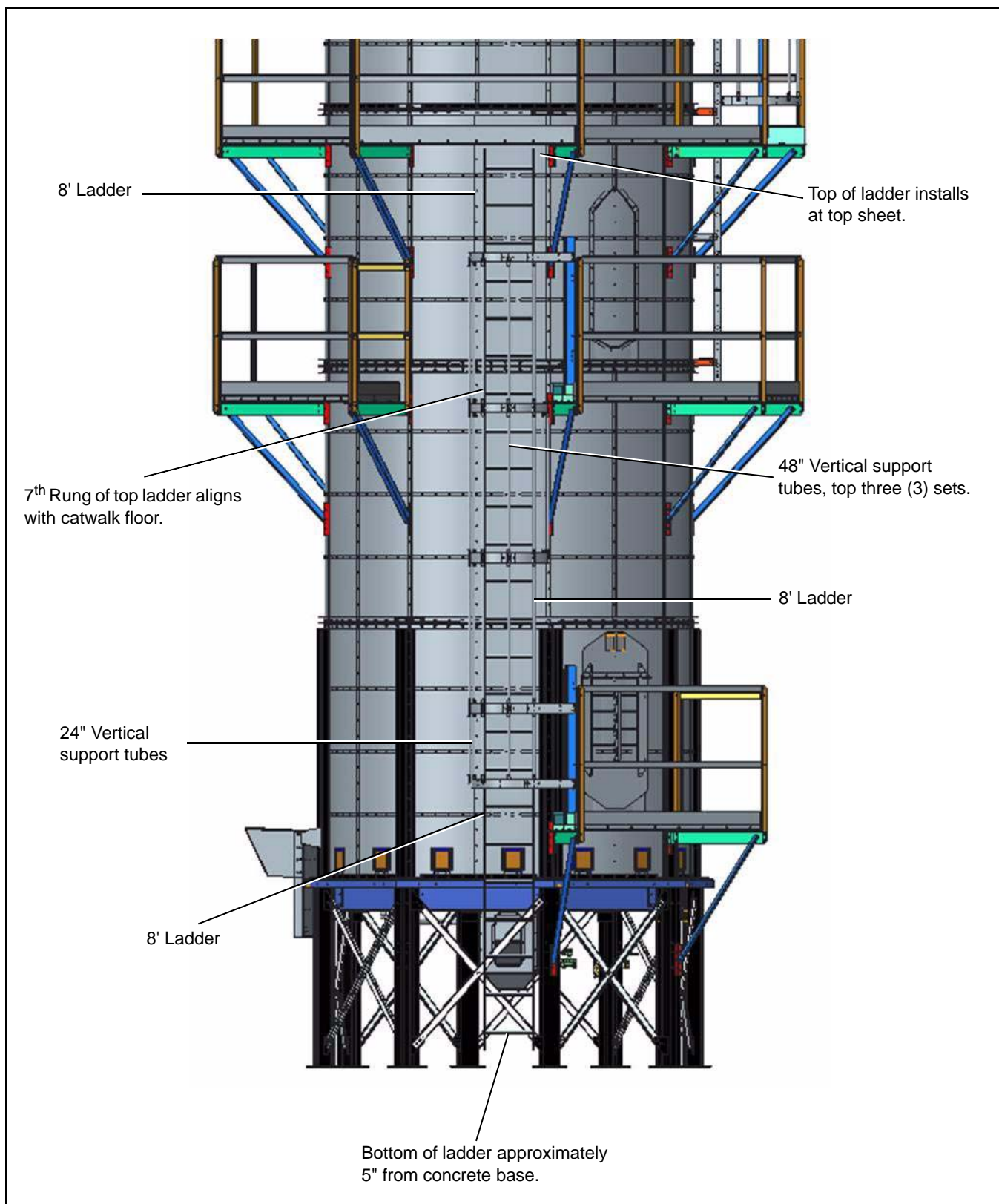

Figure 13A

13. Appendix A - TM-1008 Ladders

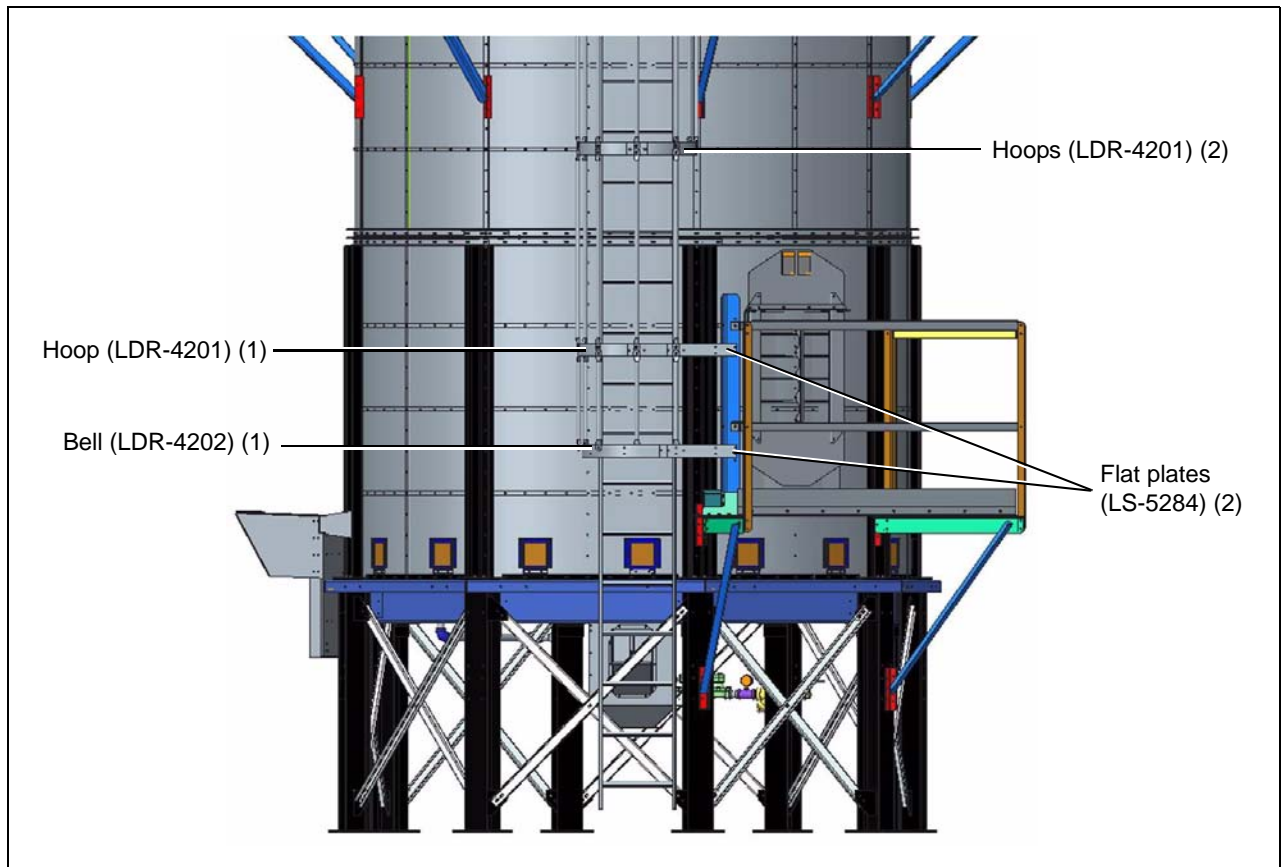

Figure 13B

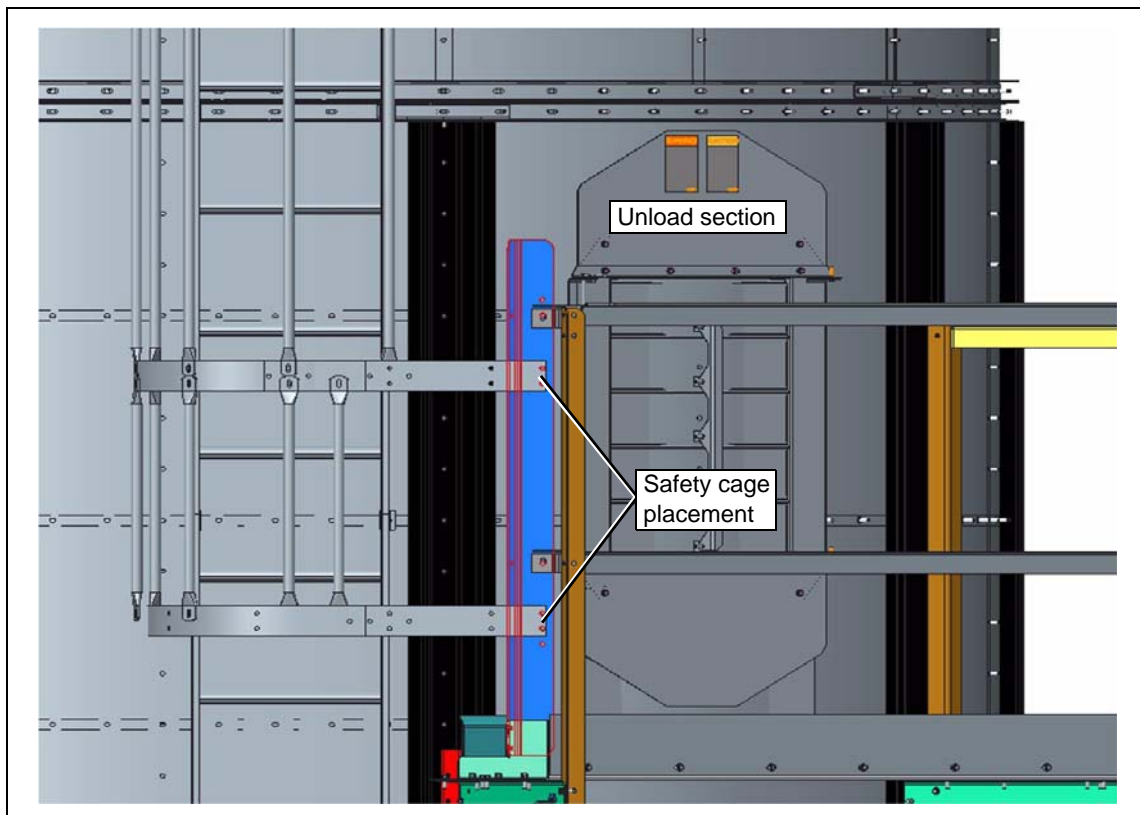

Figure 13C

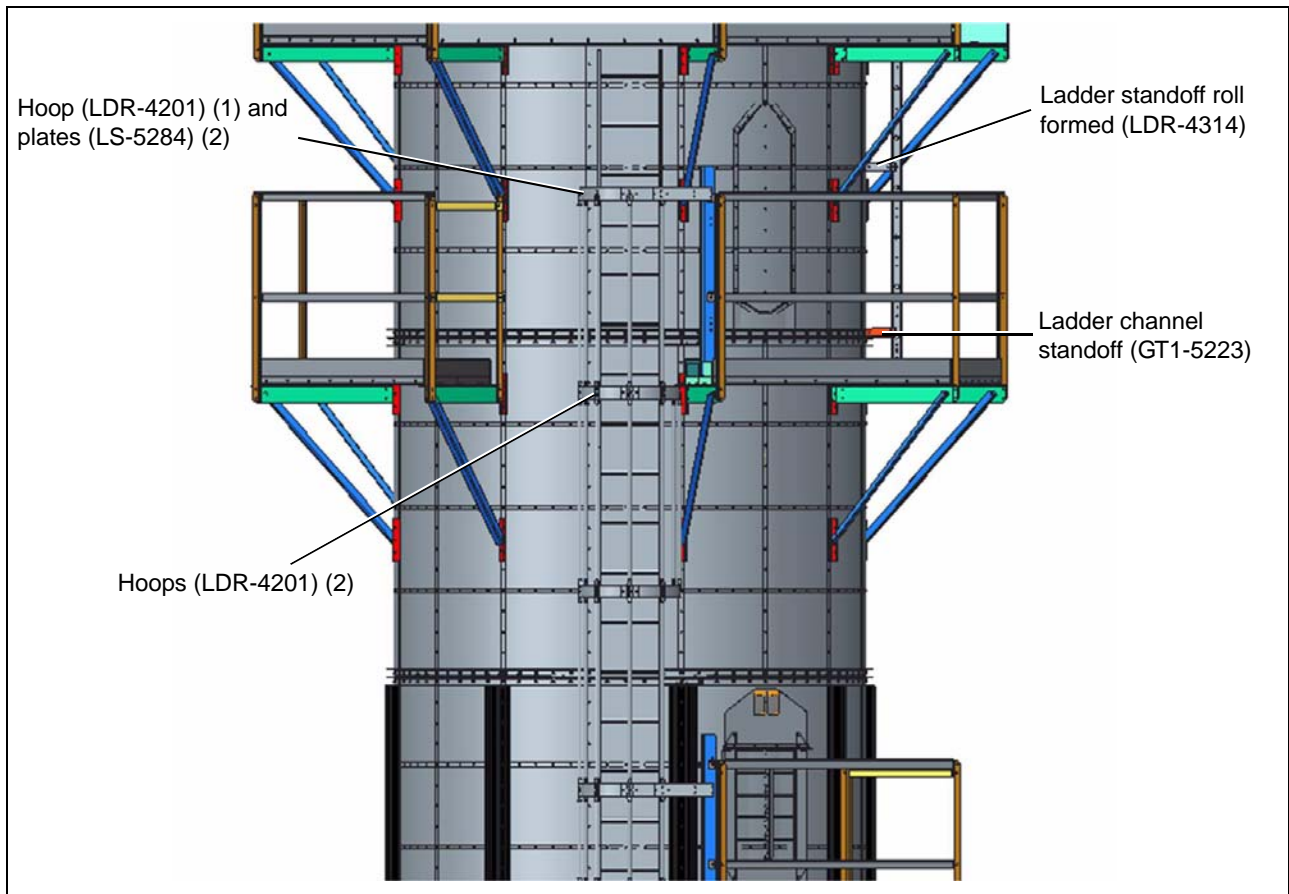

Figure 13D

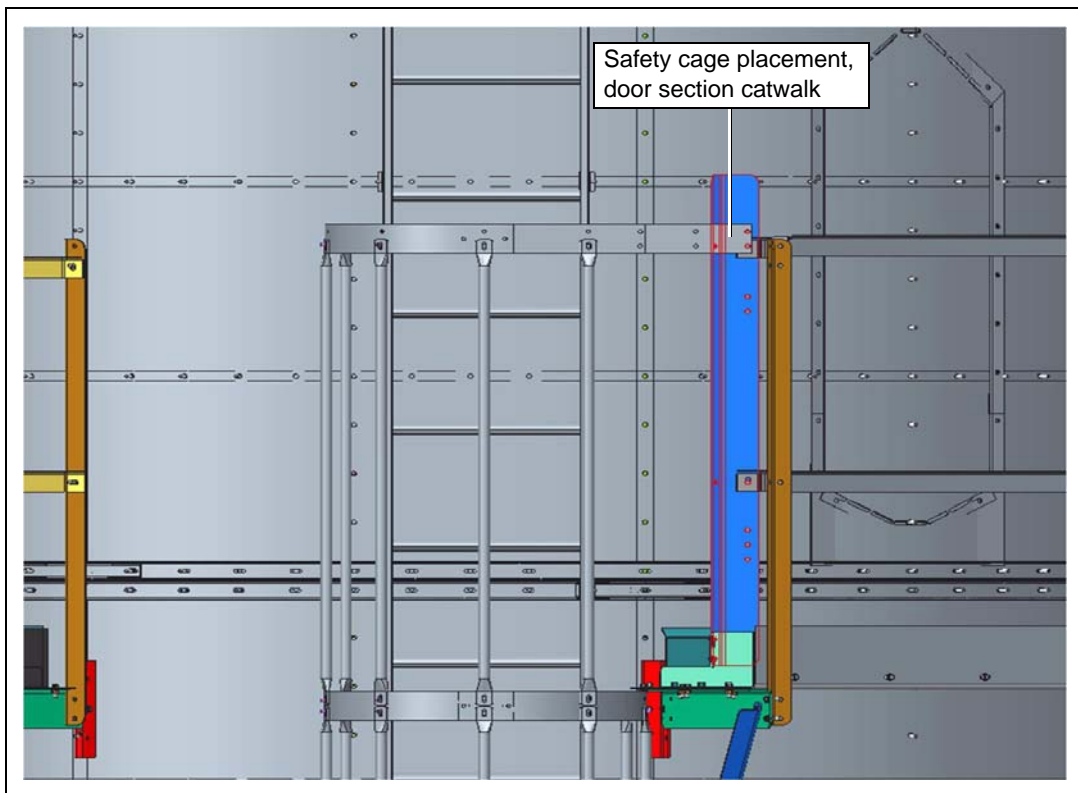

Figure 13E

13. Appendix A - TM-1008 Ladders

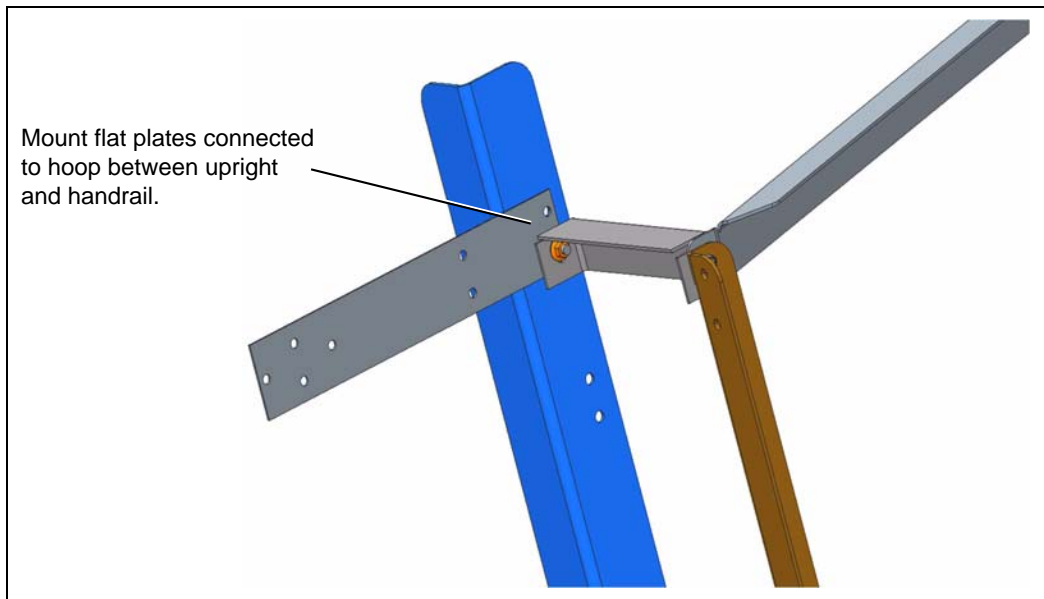

Figure 13F

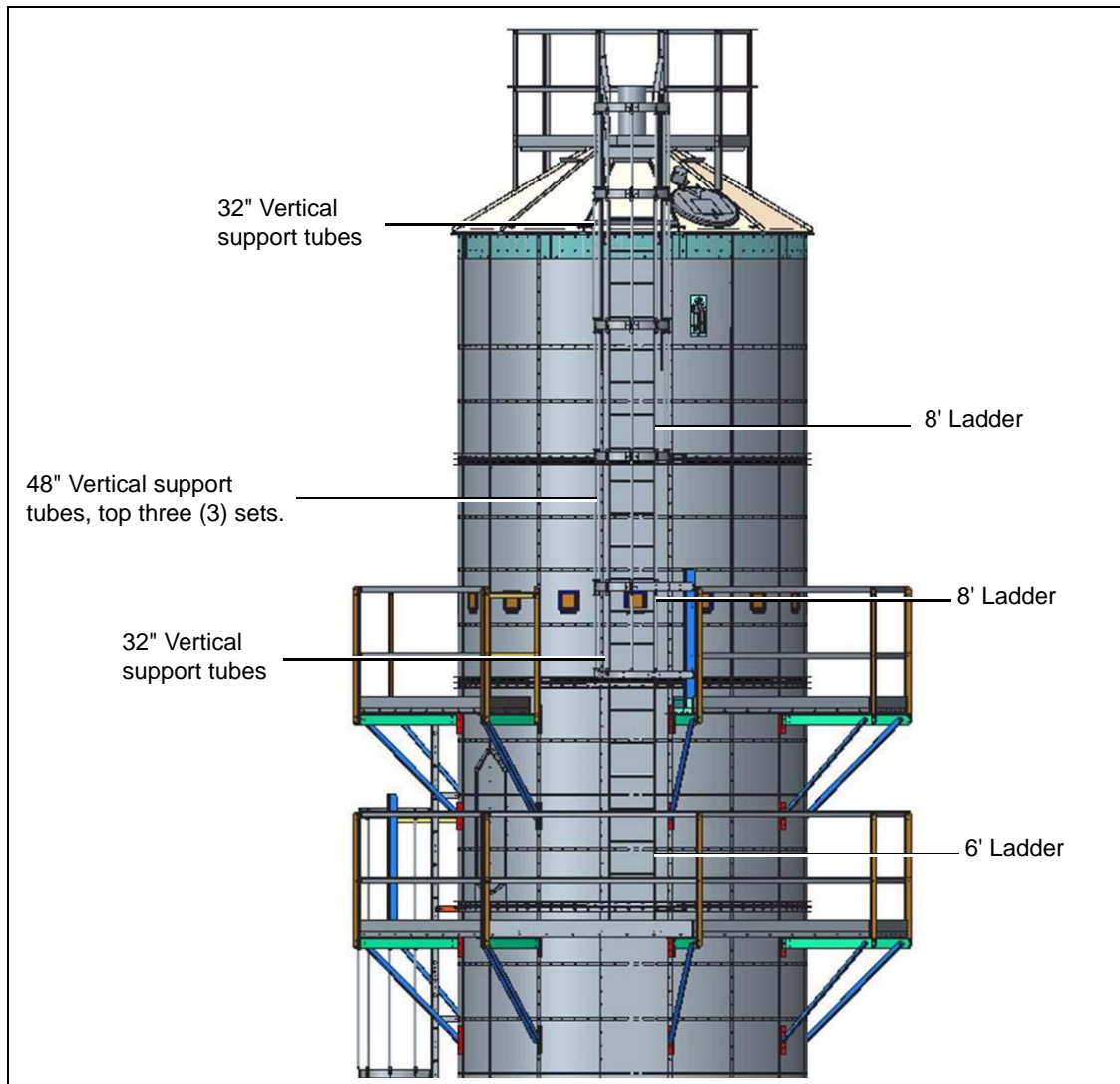

Figure 13G

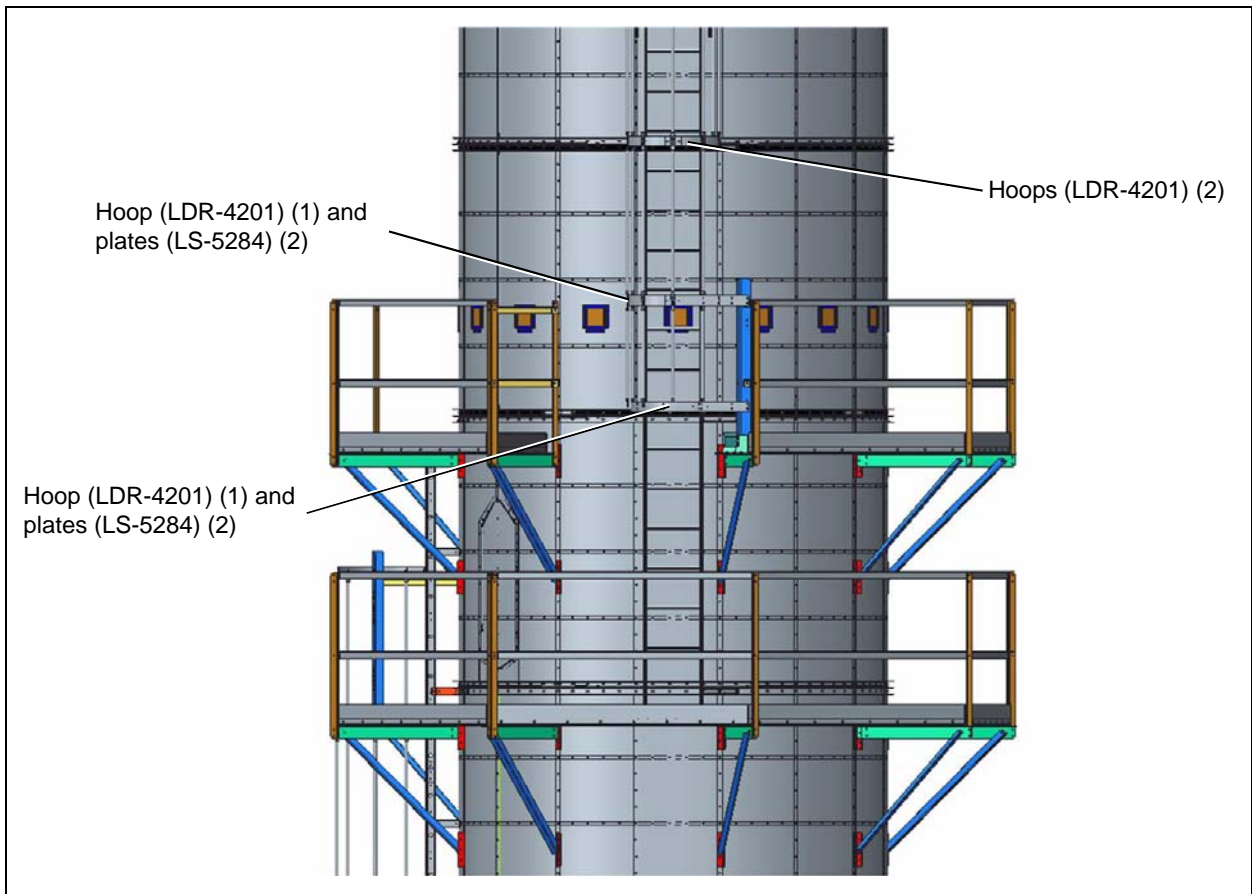

Figure 13H

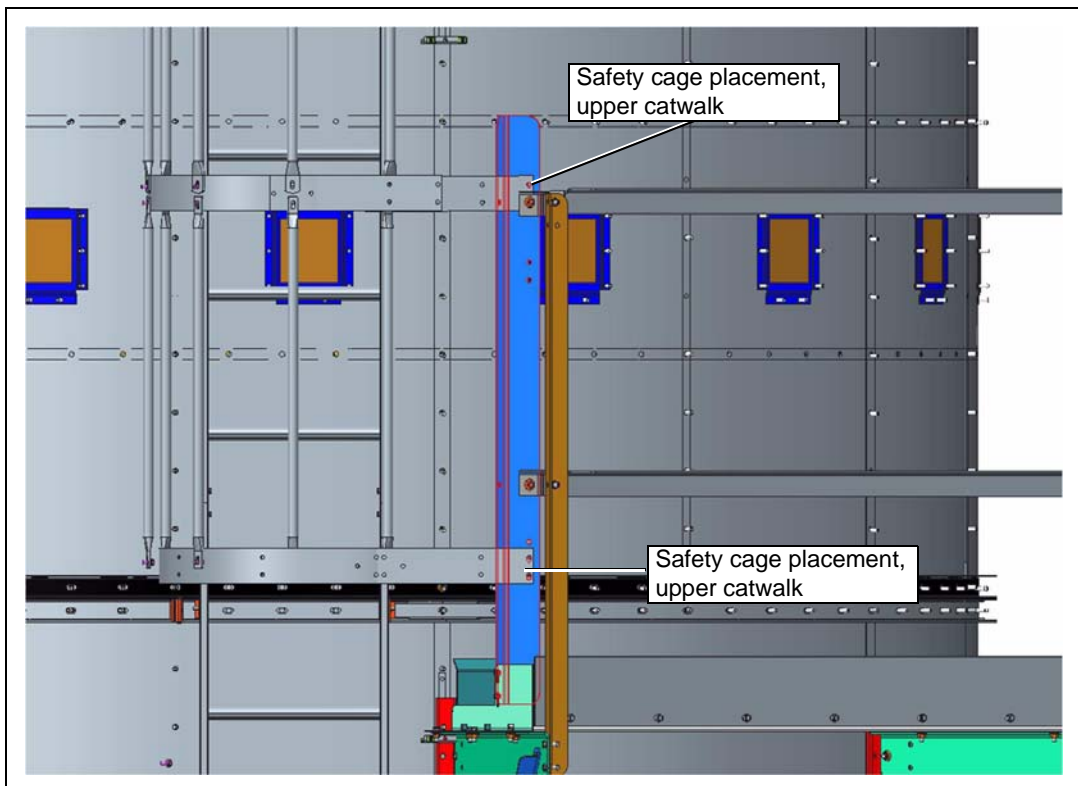

Figure 13I

13. Appendix A - TM-1008 Ladders

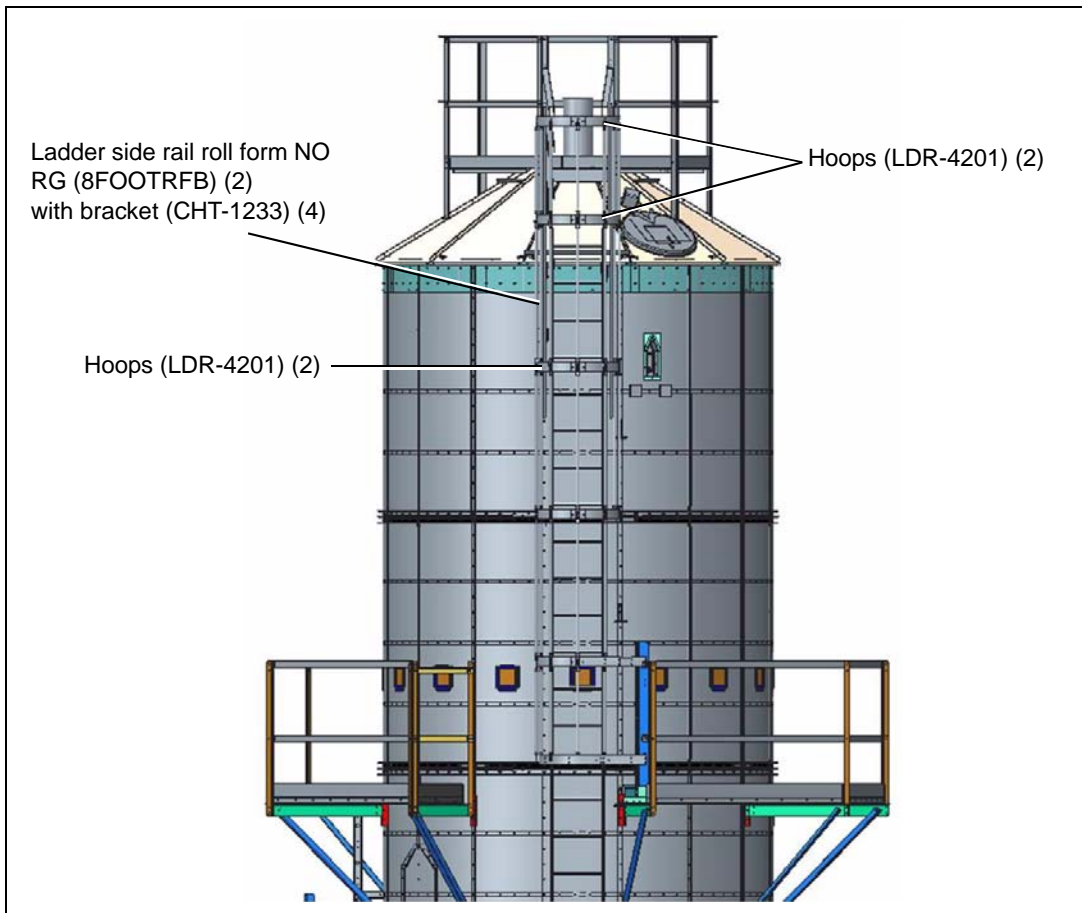

Figure 13J

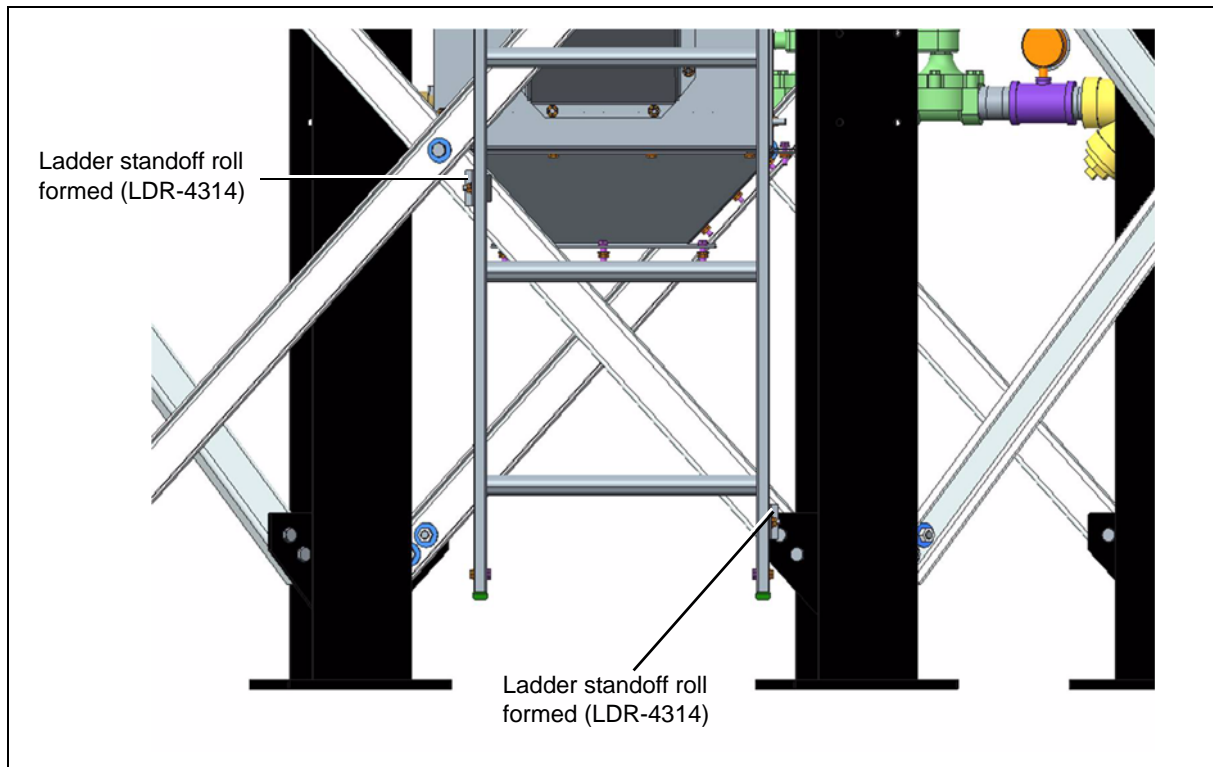

Figure 13K

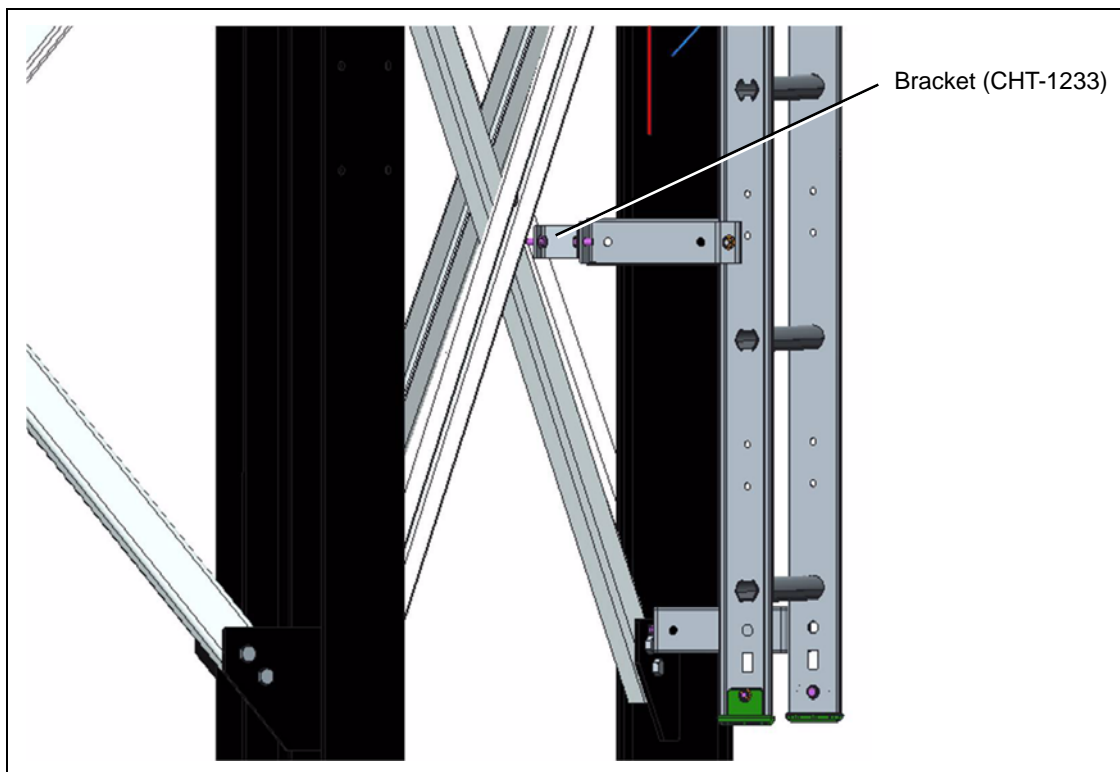

Figure 13L



Figure 13M

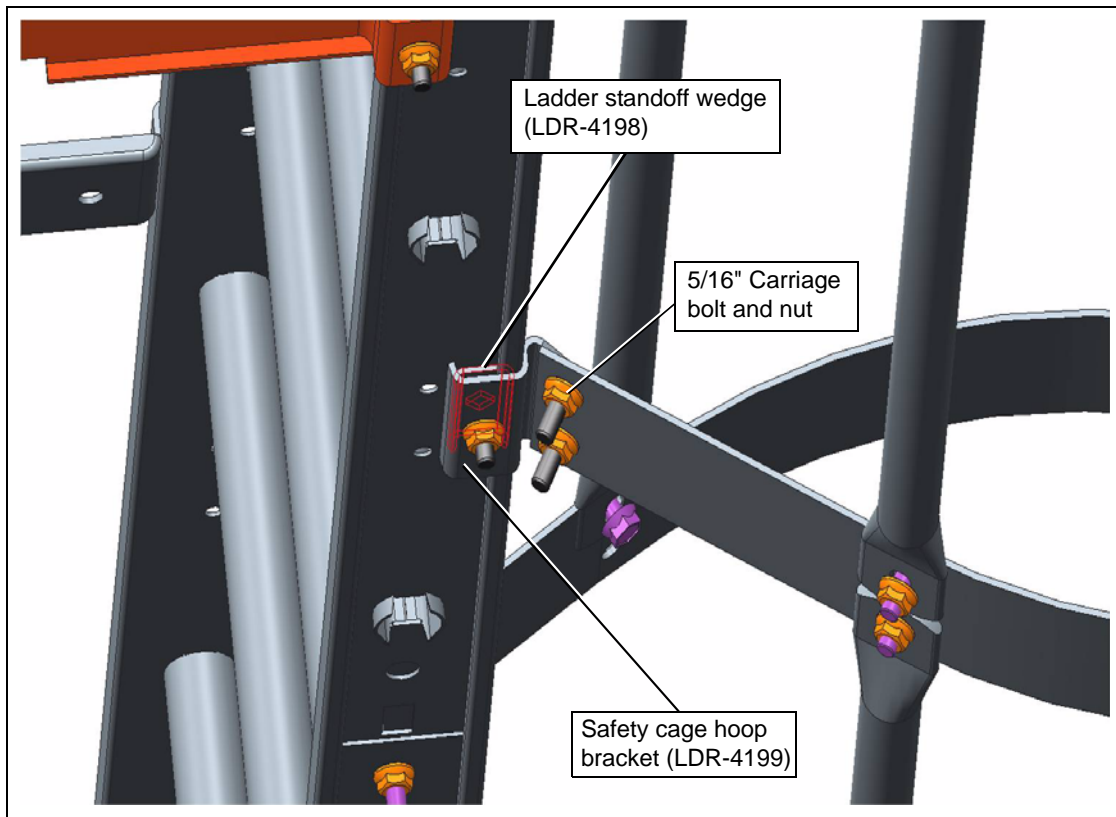

Figure 13N

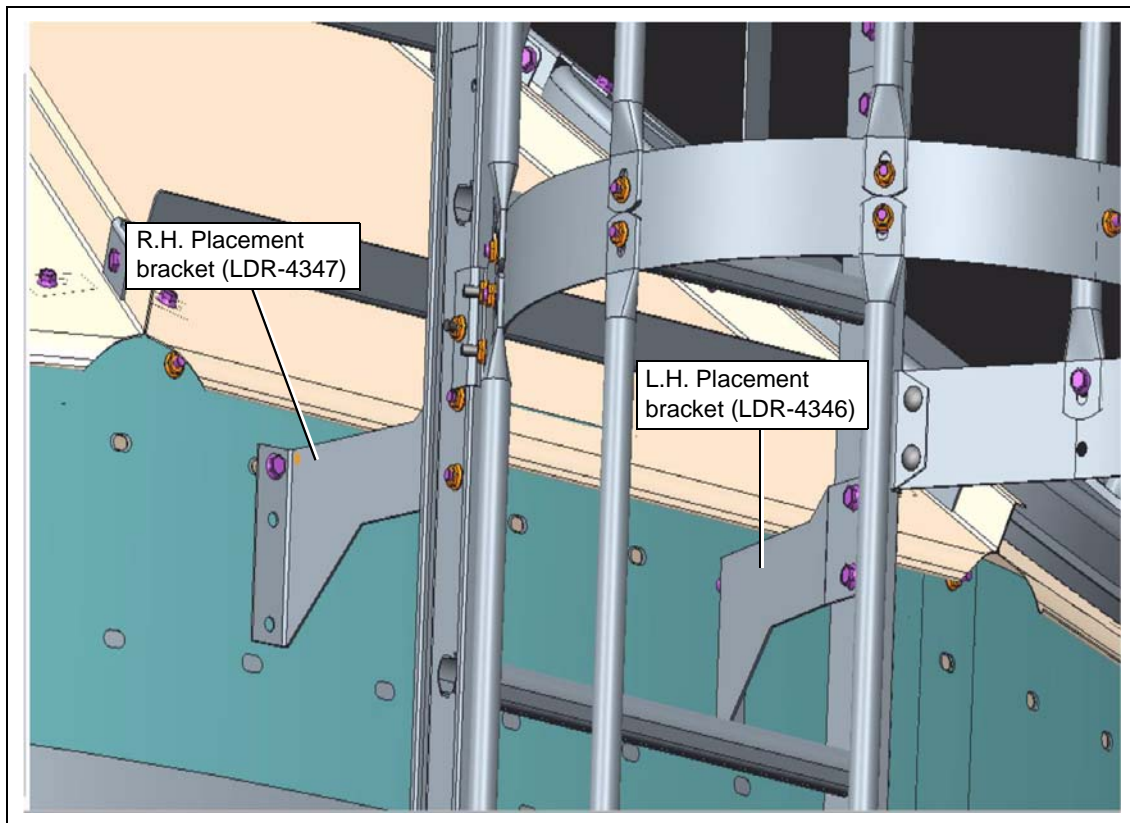

Figure 13O

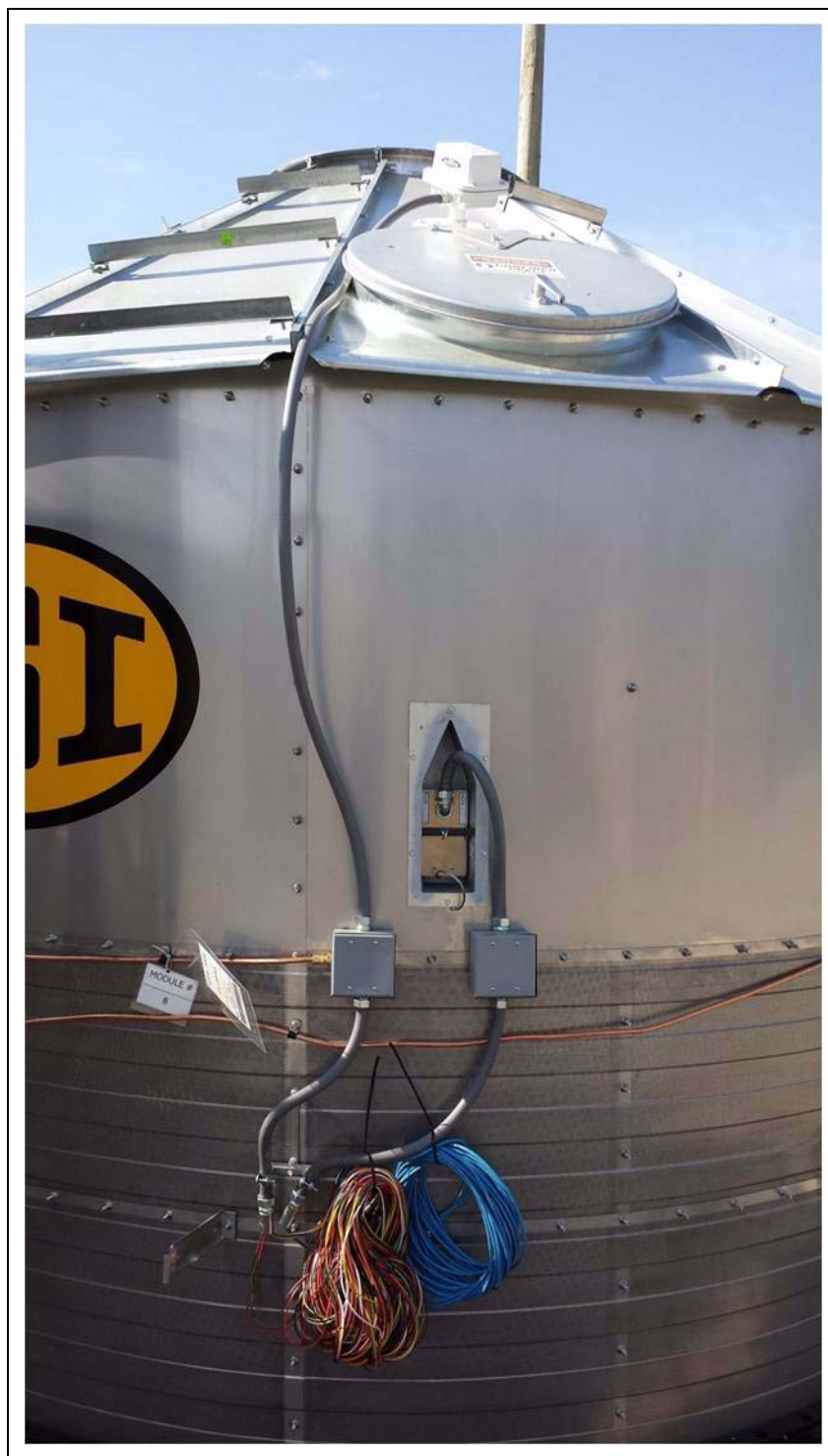

Figure 13P

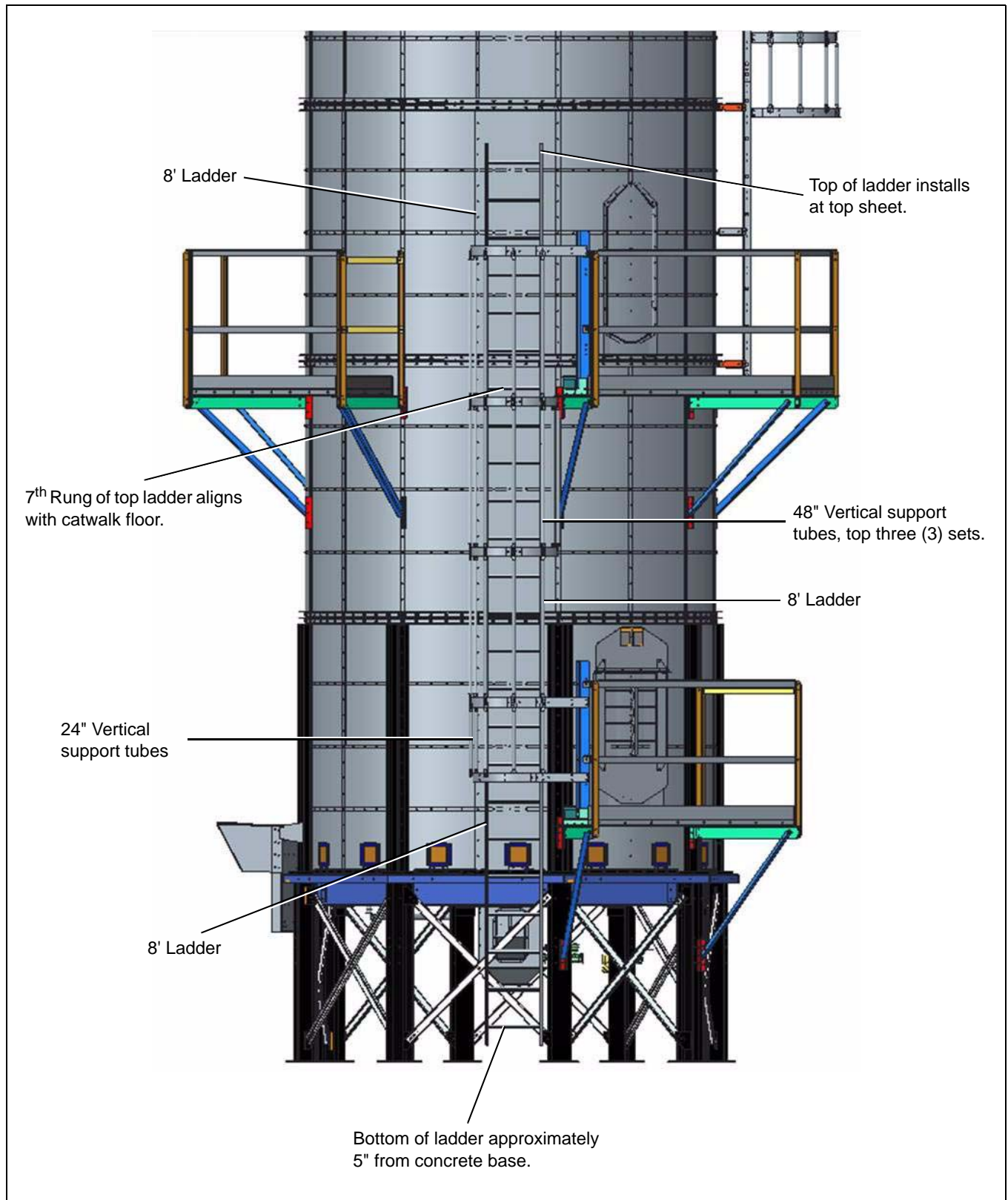

Figure 14A

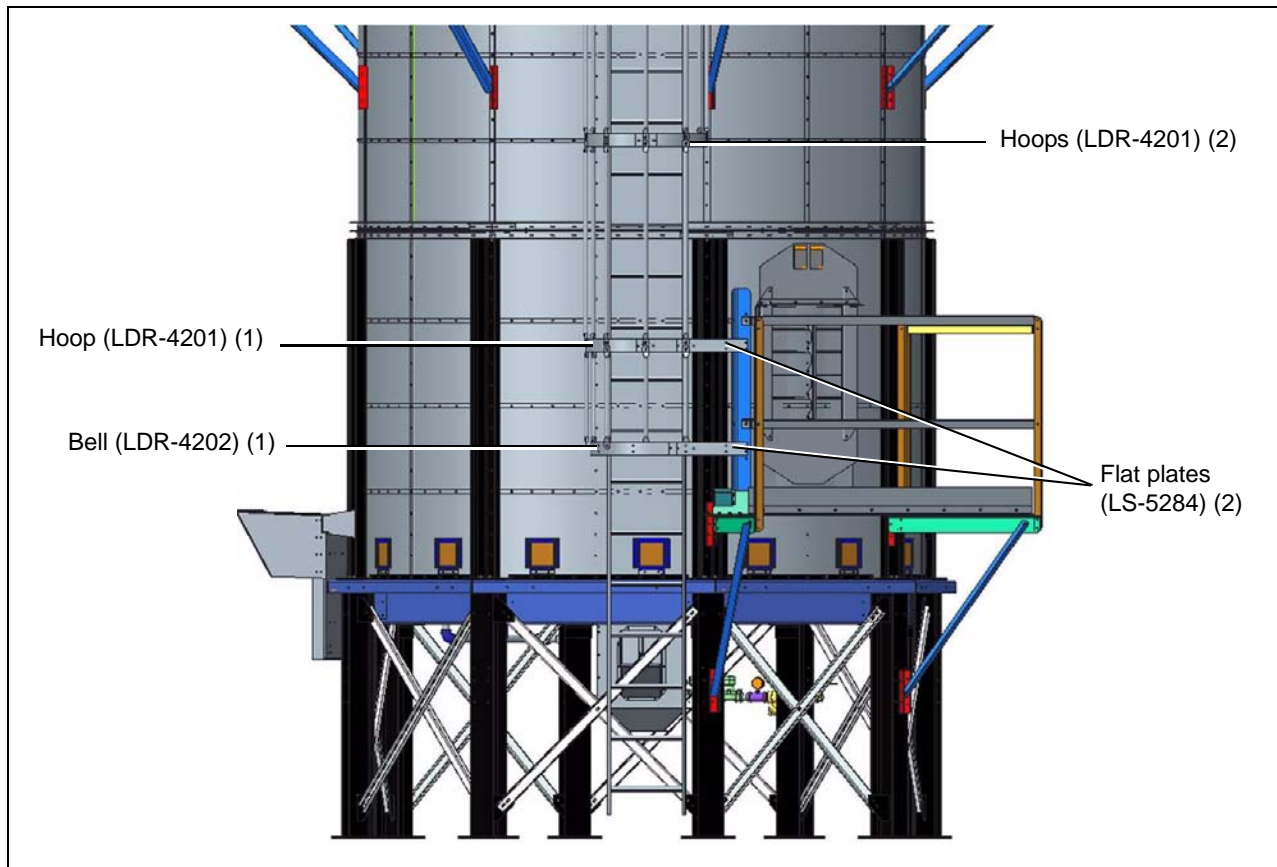

Figure 14B

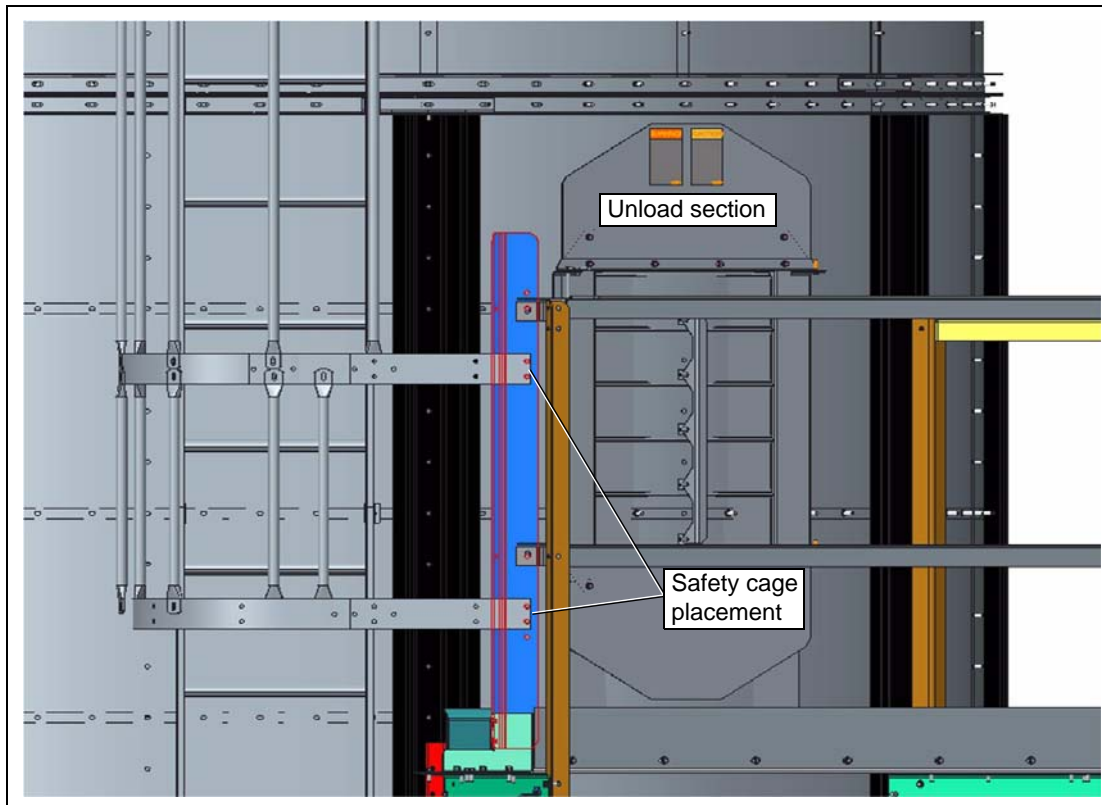

Figure 14C

14. Appendix B - TM-1010 Ladders

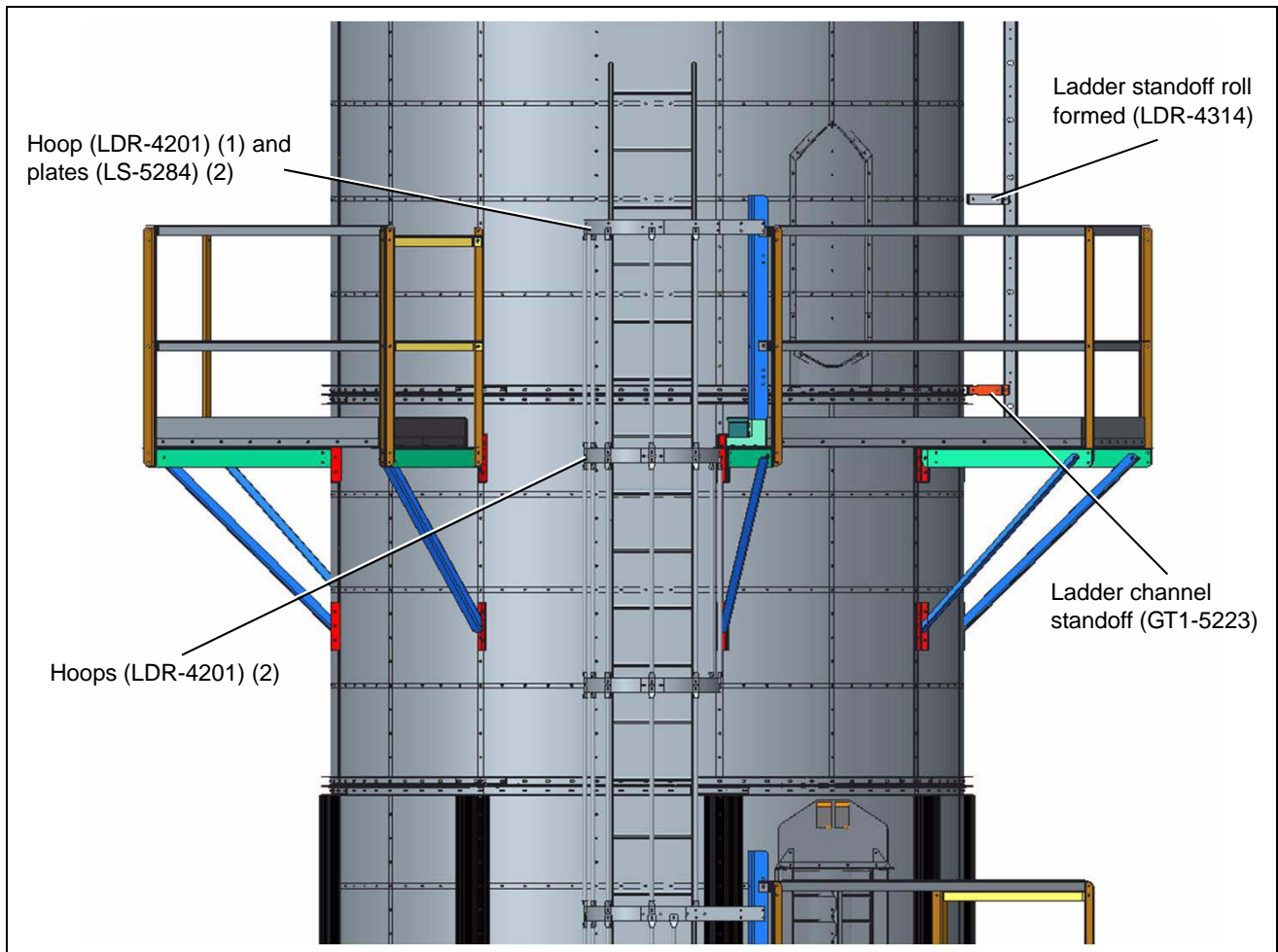

Figure 14D

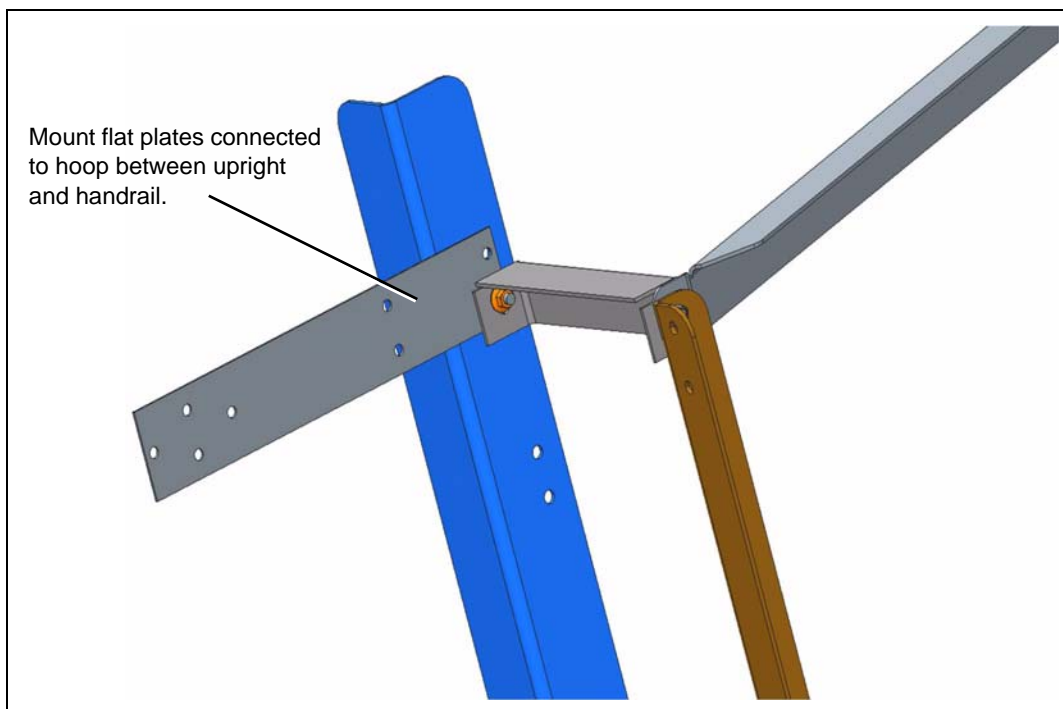

Figure 14E

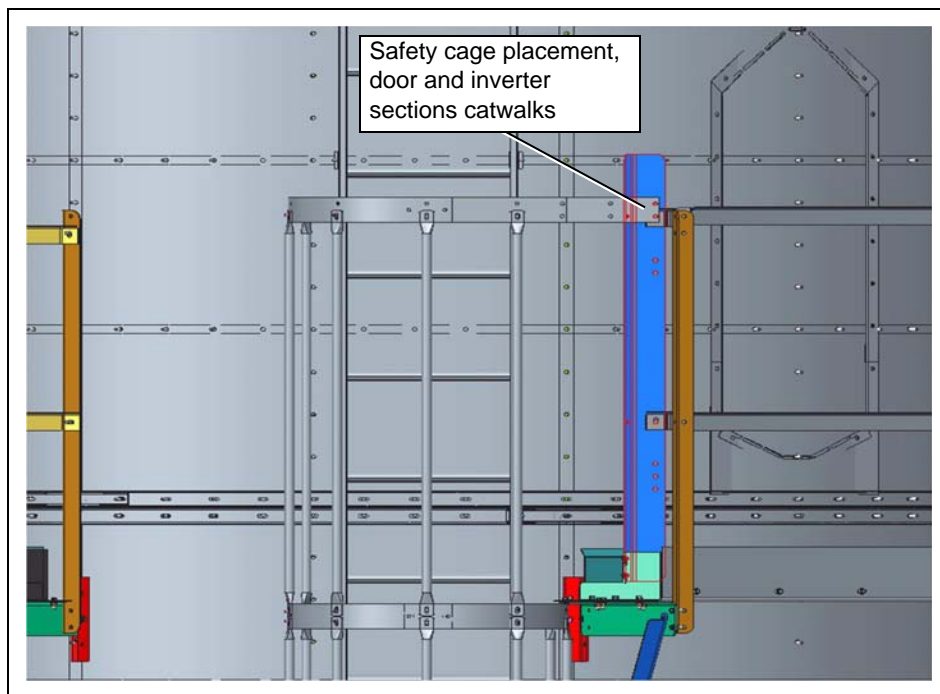

Figure 14F

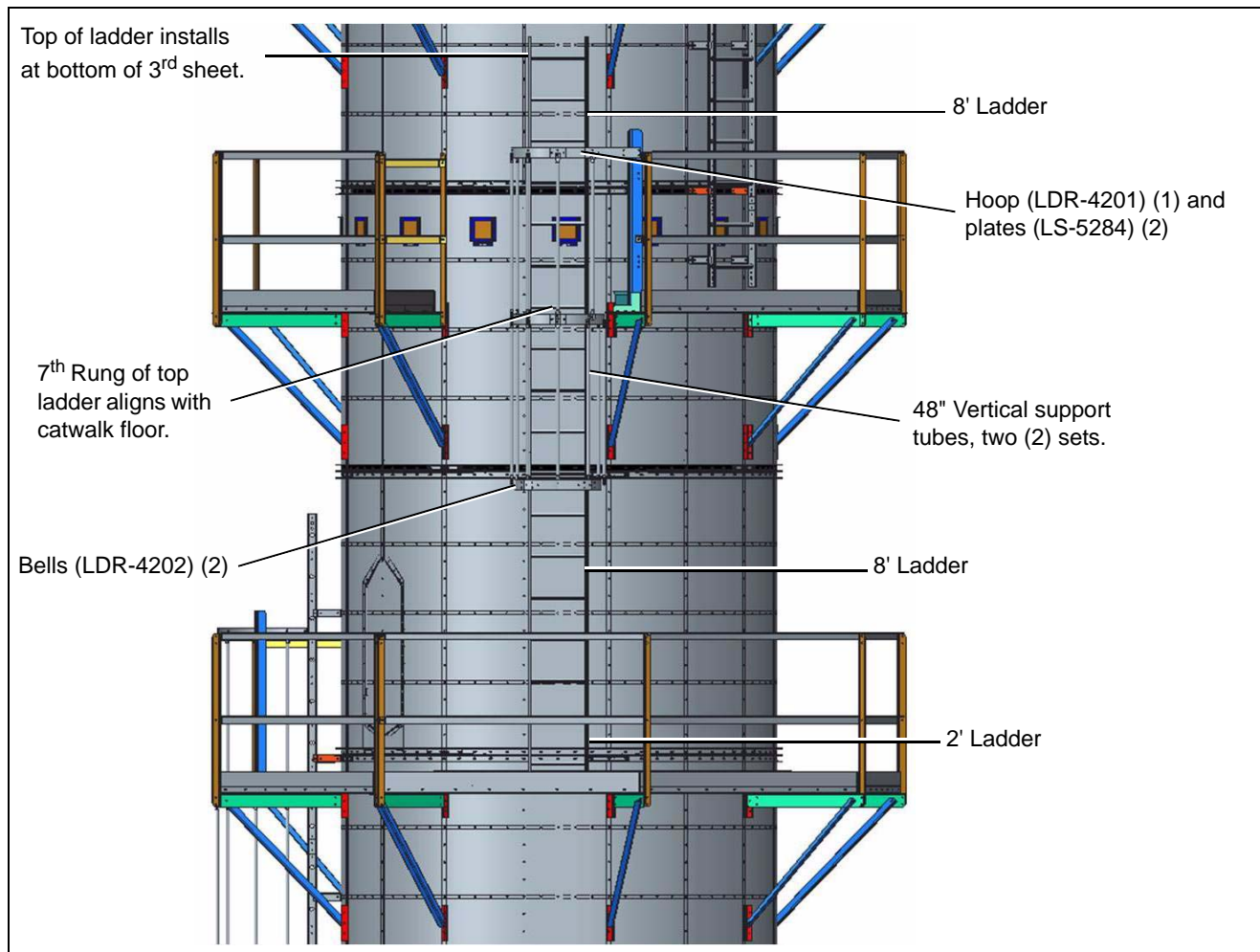

Figure 14G

14. Appendix B - TM-1010 Ladders

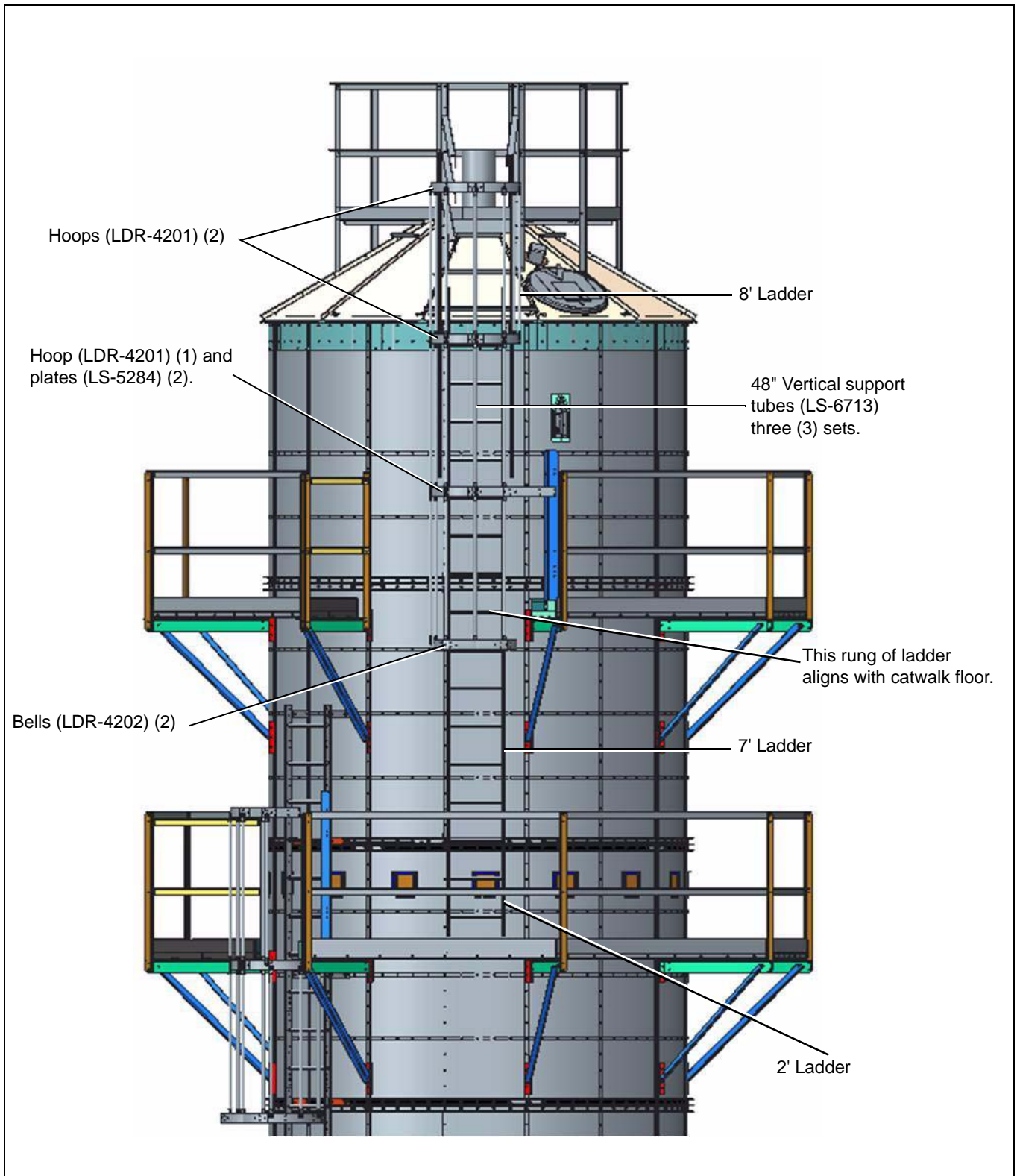

Figure 14H

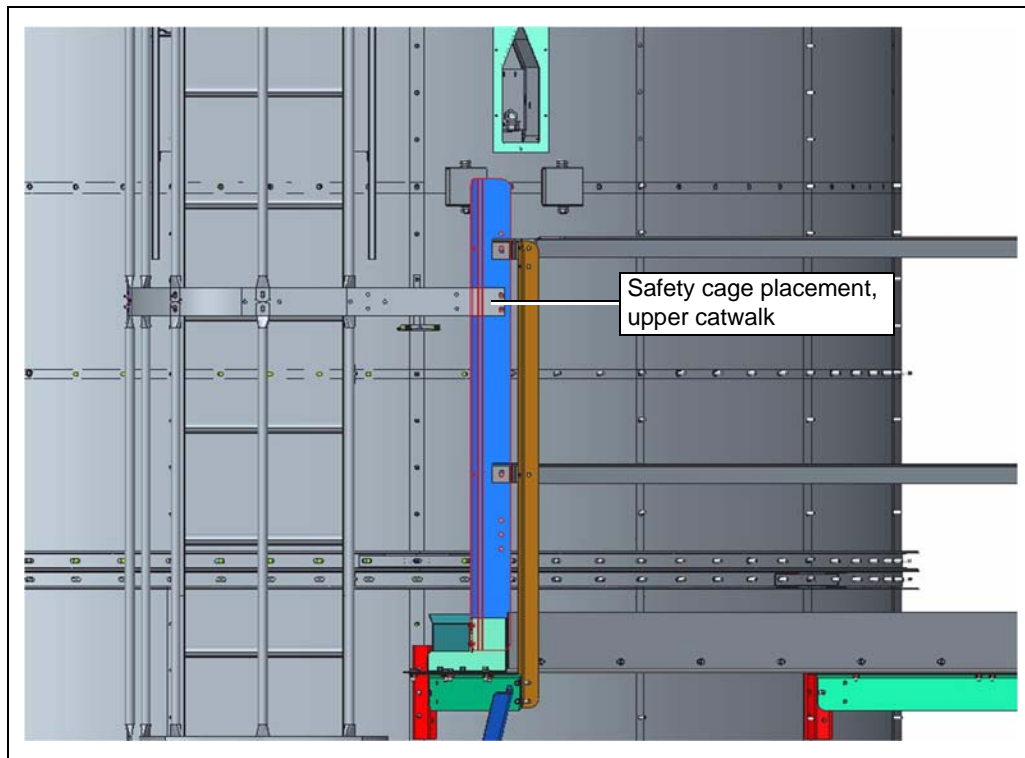

Figure 14I

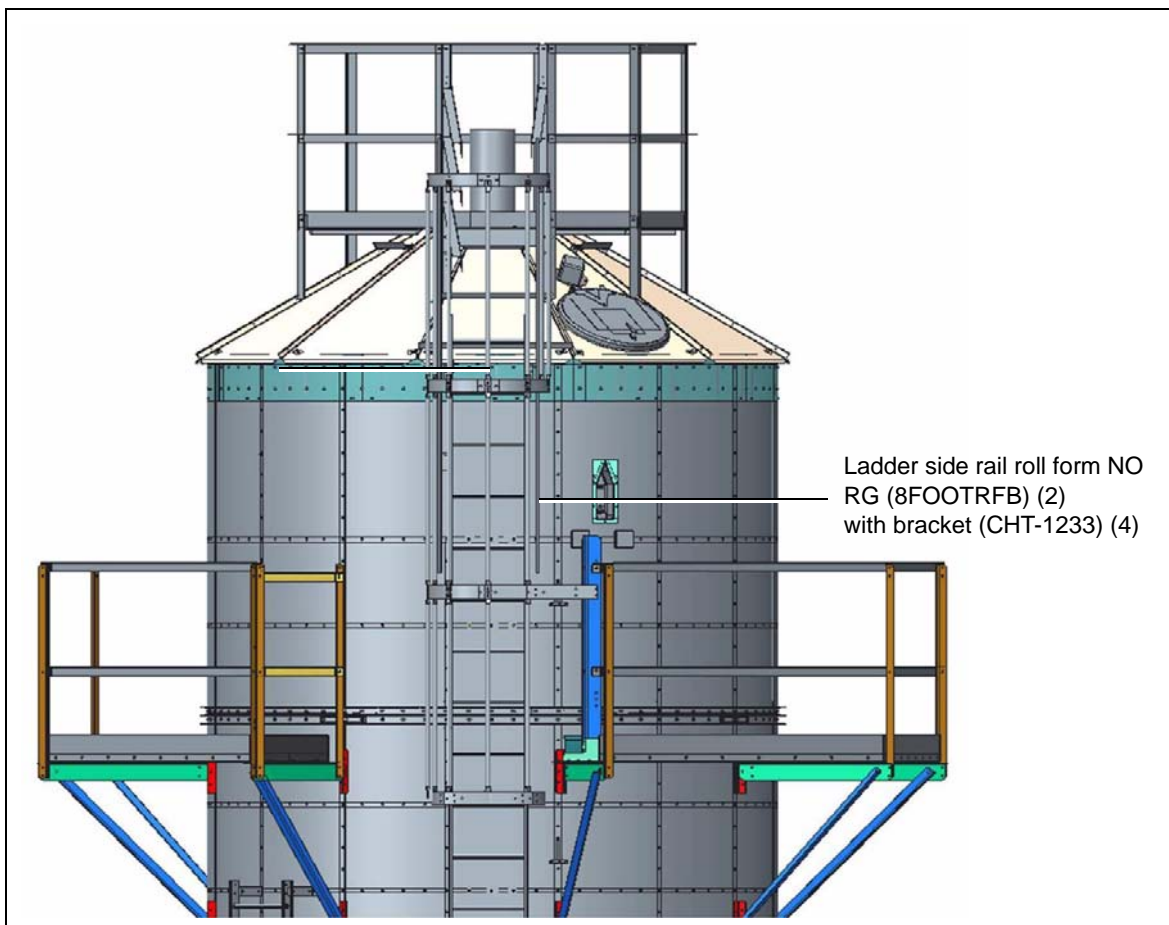

Figure 14J

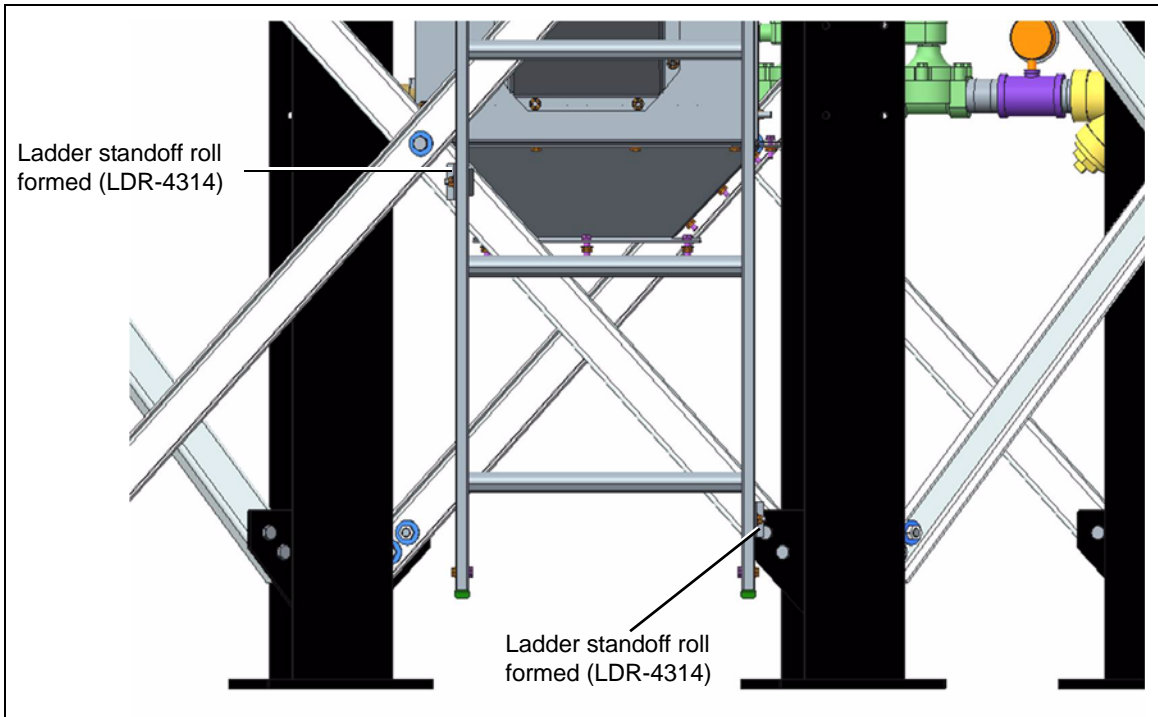

Figure 14K

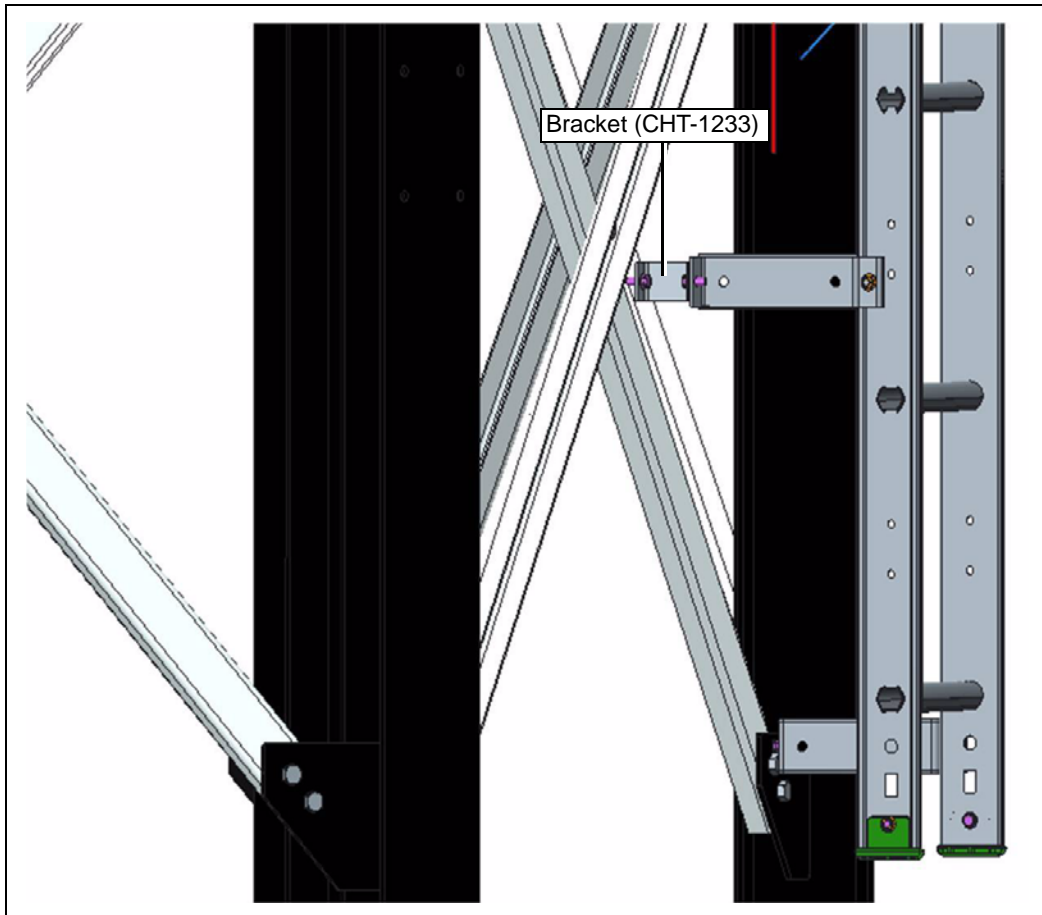

Figure 14L



Figure 14M

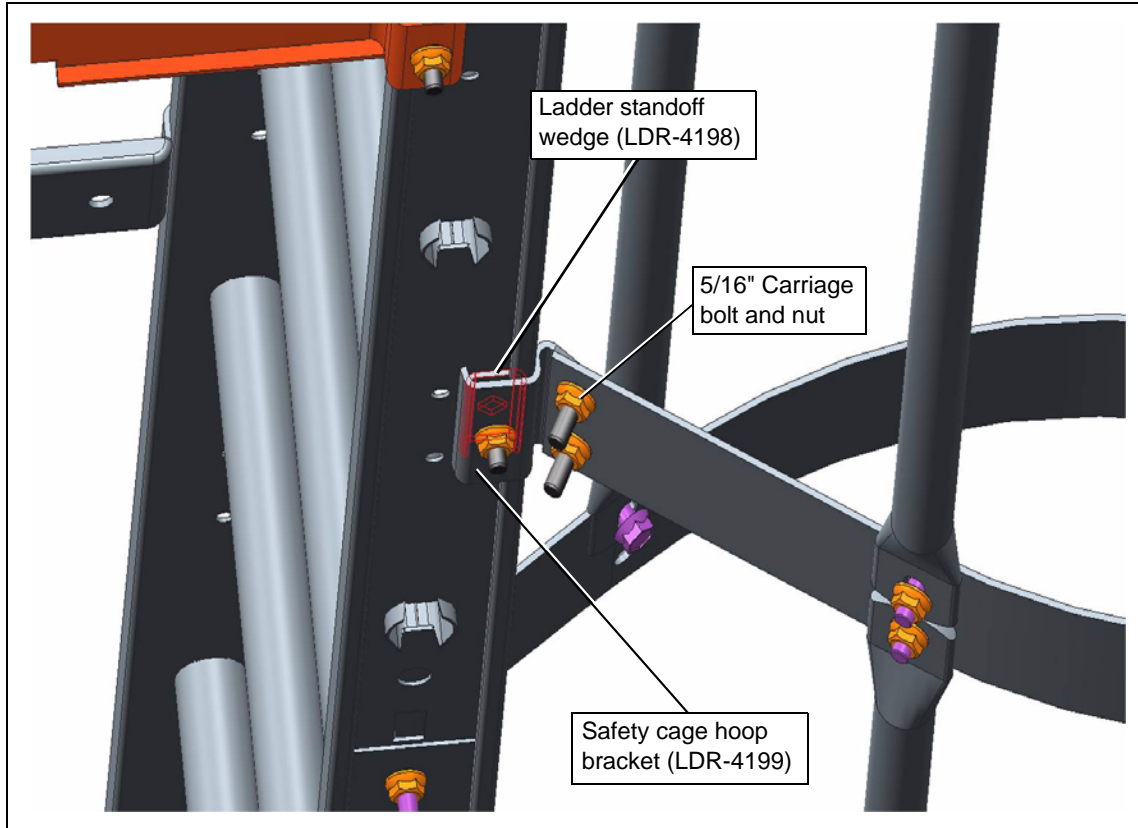

Figure 14N

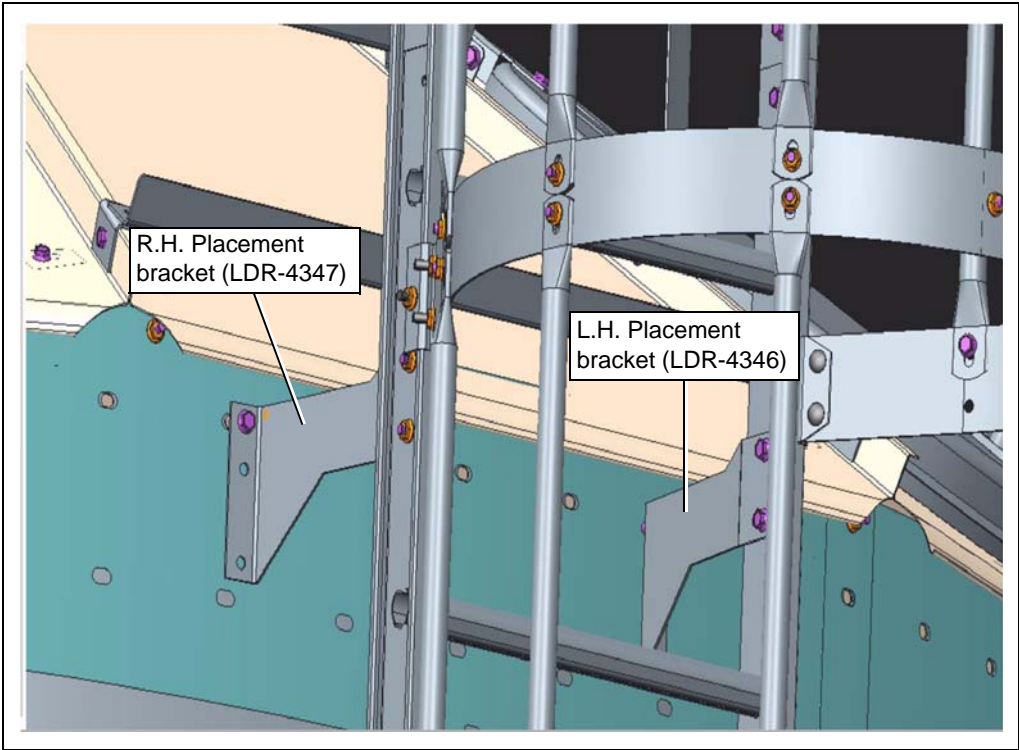

Figure 14O

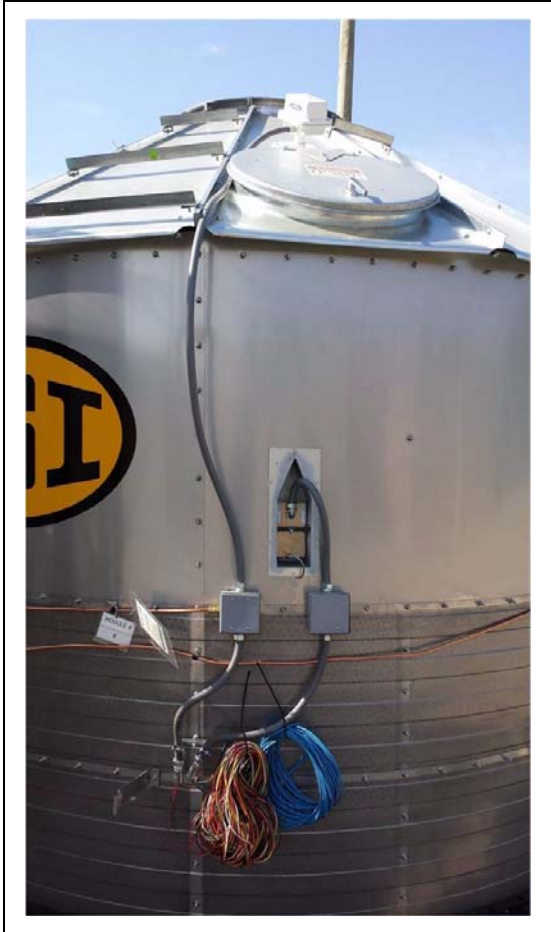

Figure 14P

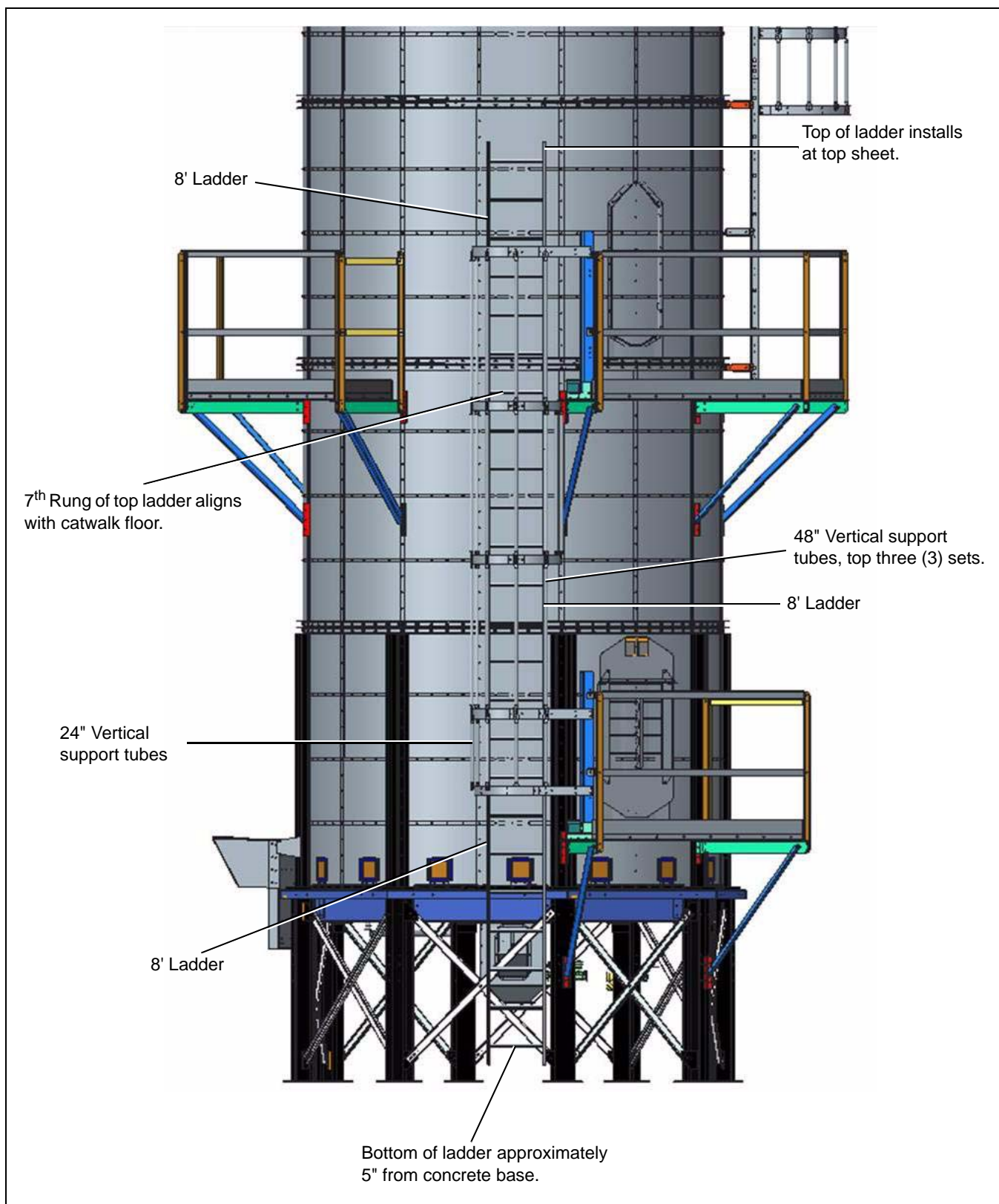

Figure 15A

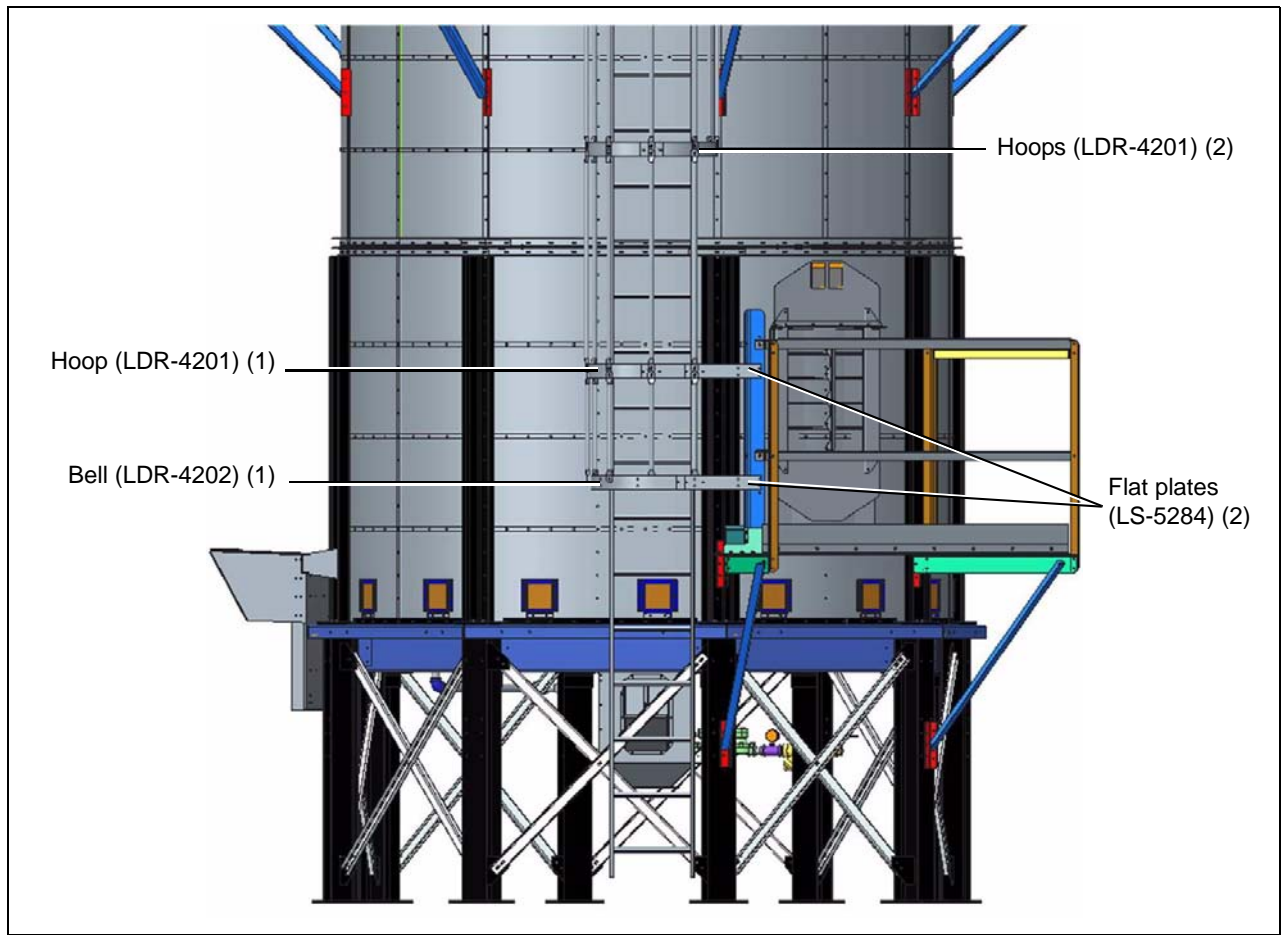

Figure 15B

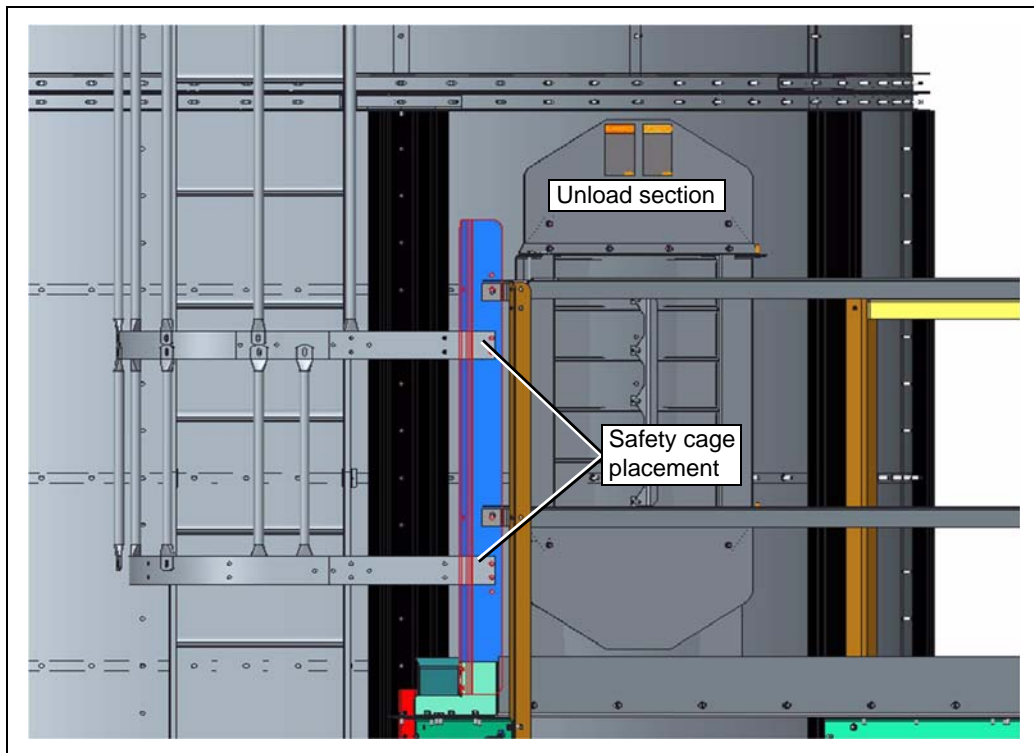

Figure 15C

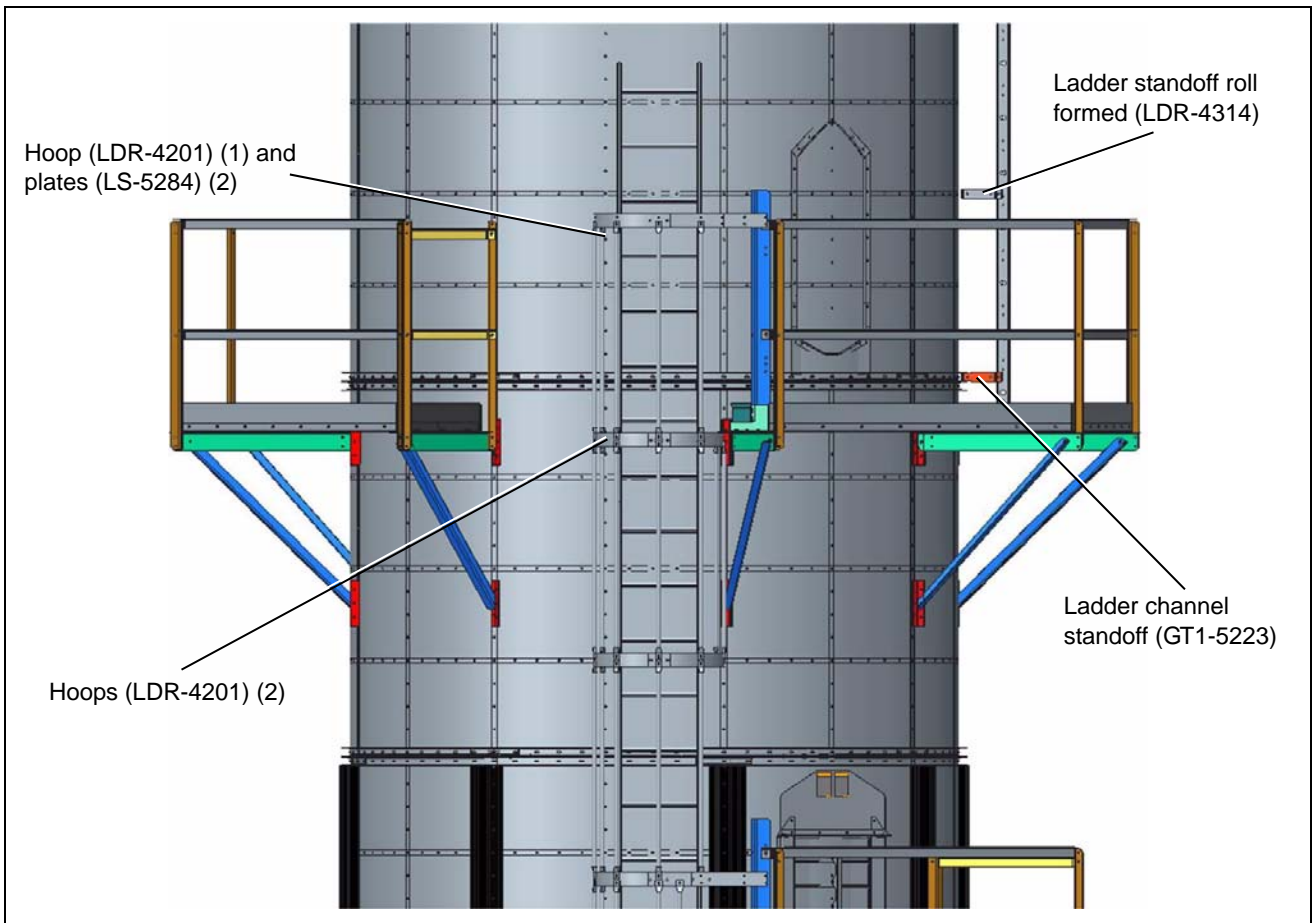

Figure 15D

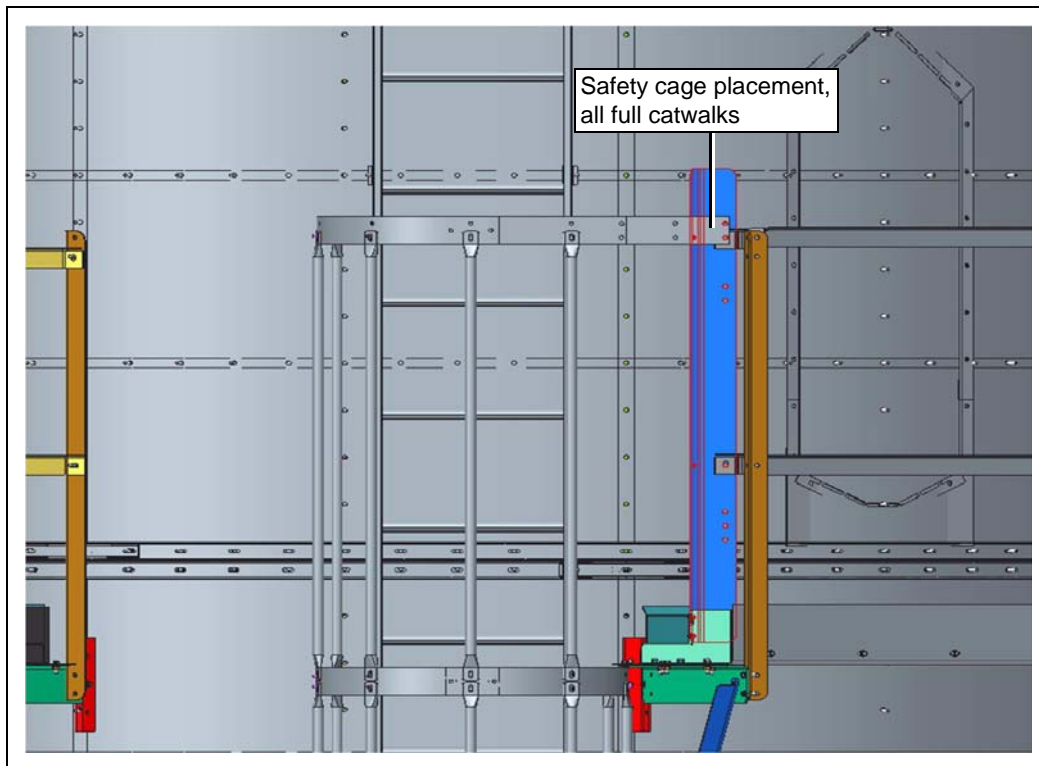

Figure 15E

15. Appendix C - TM-1012 Ladders

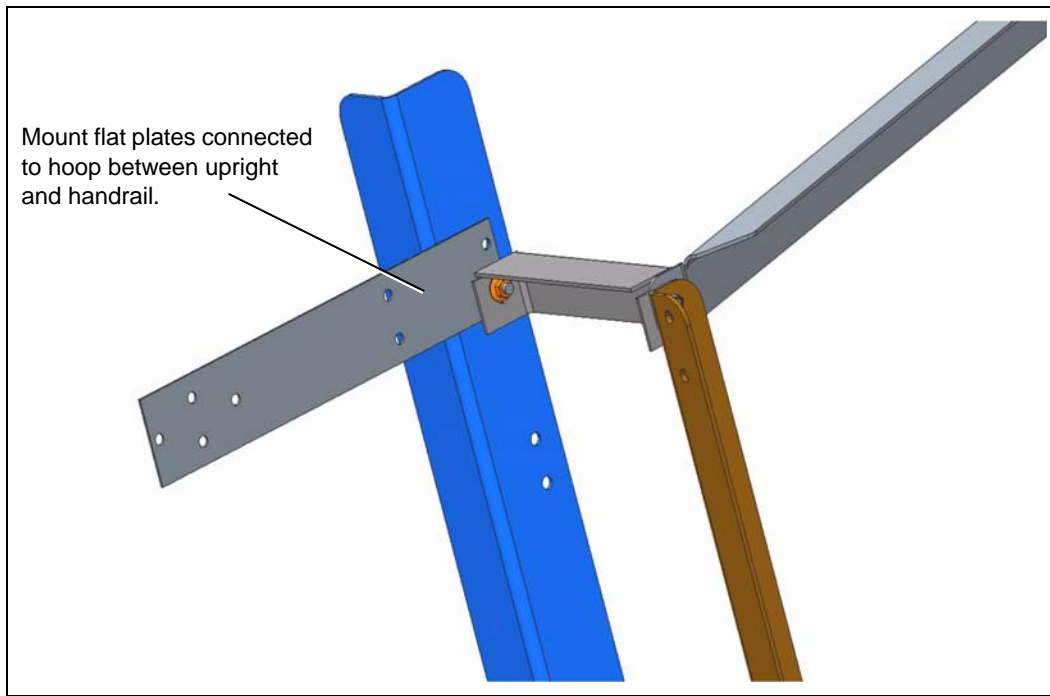

Figure 15F

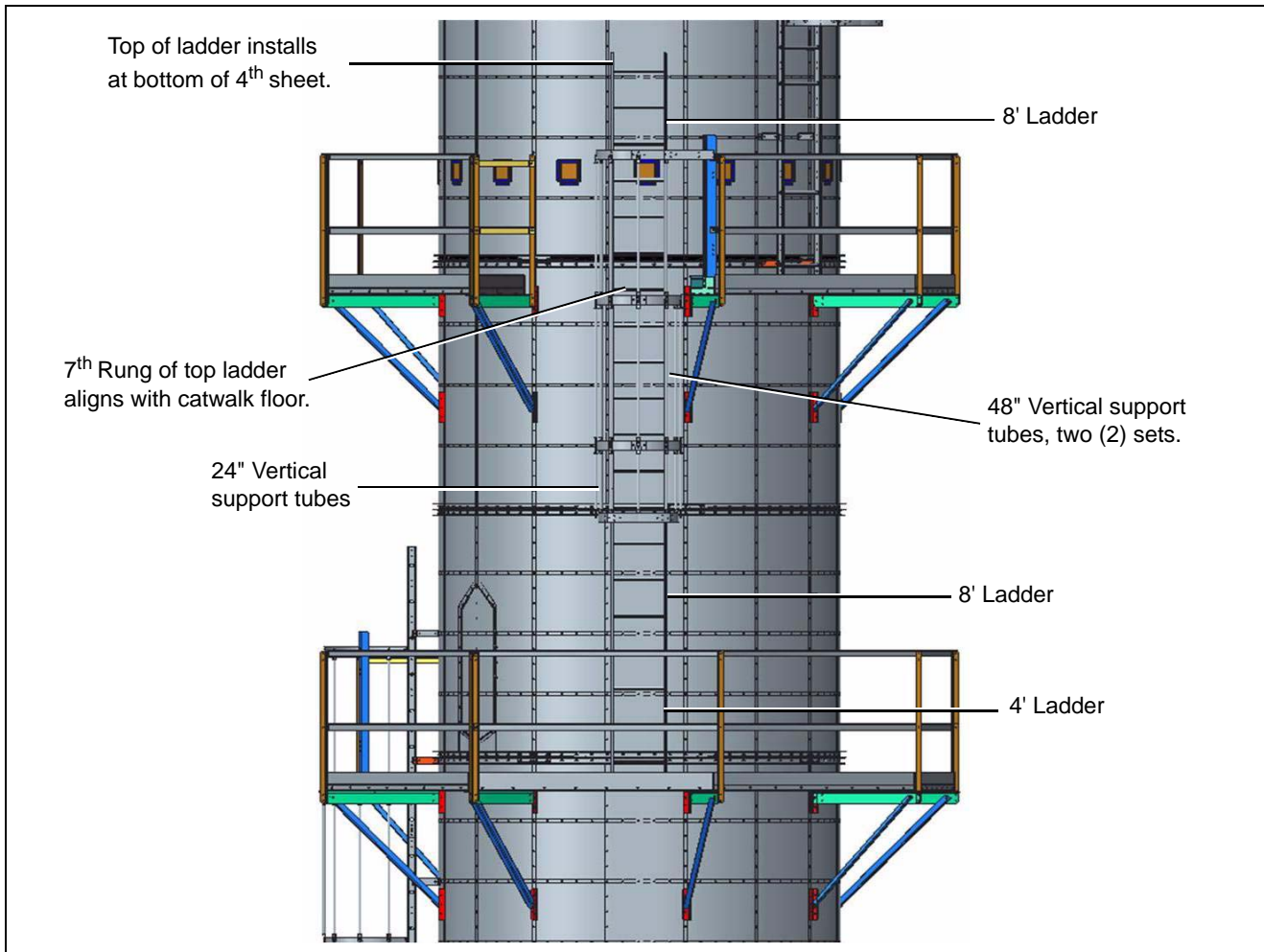

Figure 15G

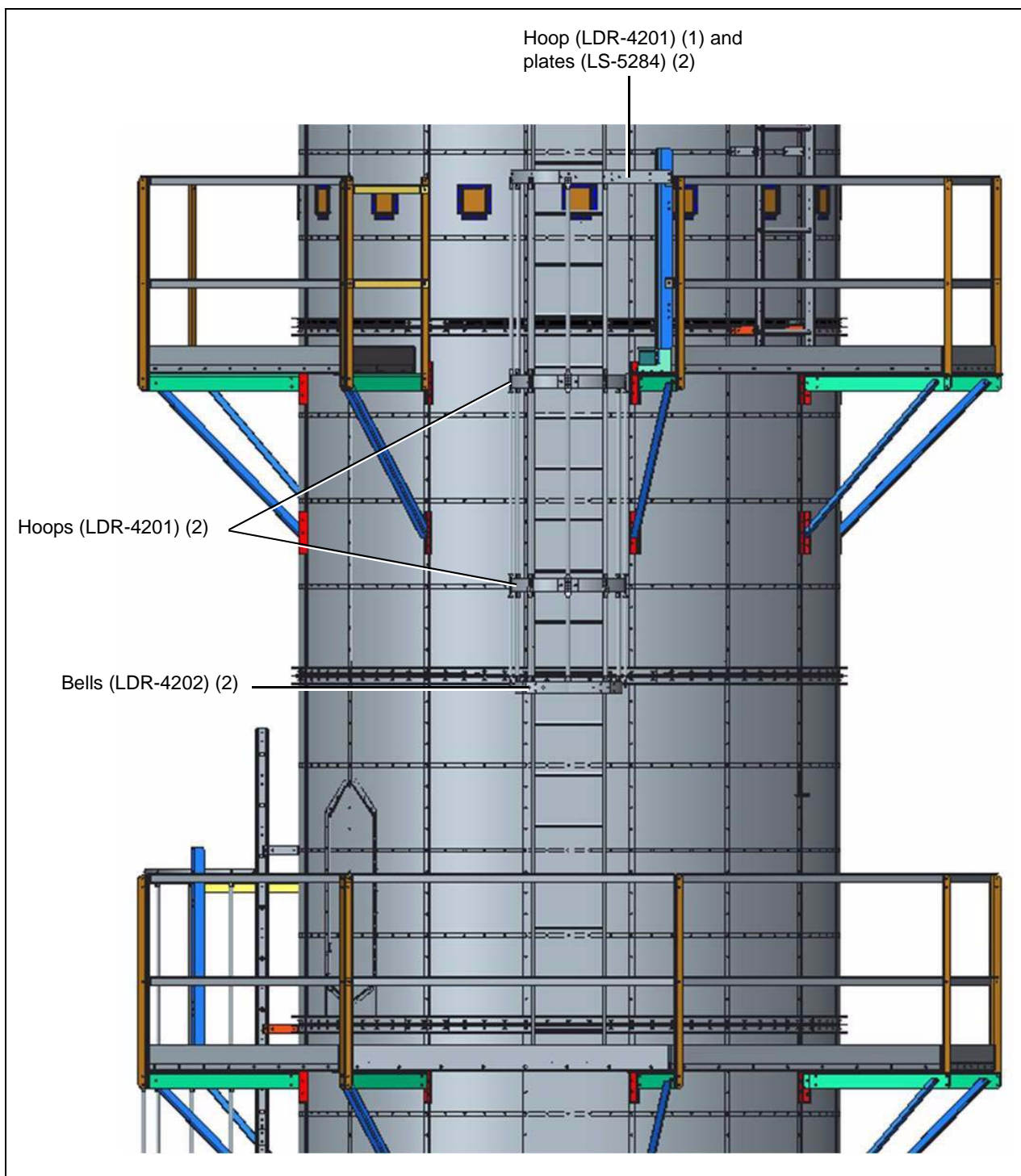

Figure 15H

15. Appendix C - TM-1012 Ladders

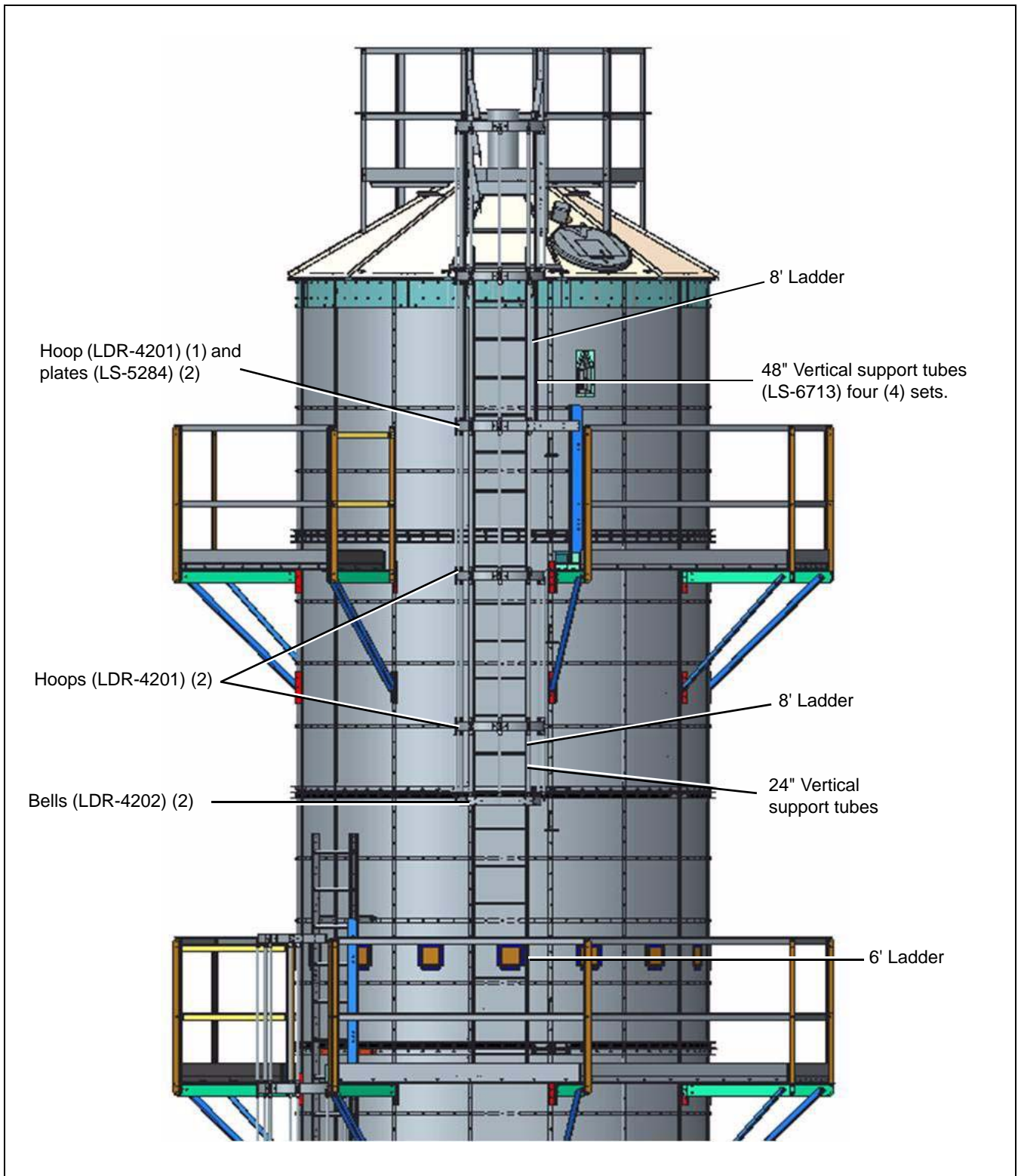

Figure 15I

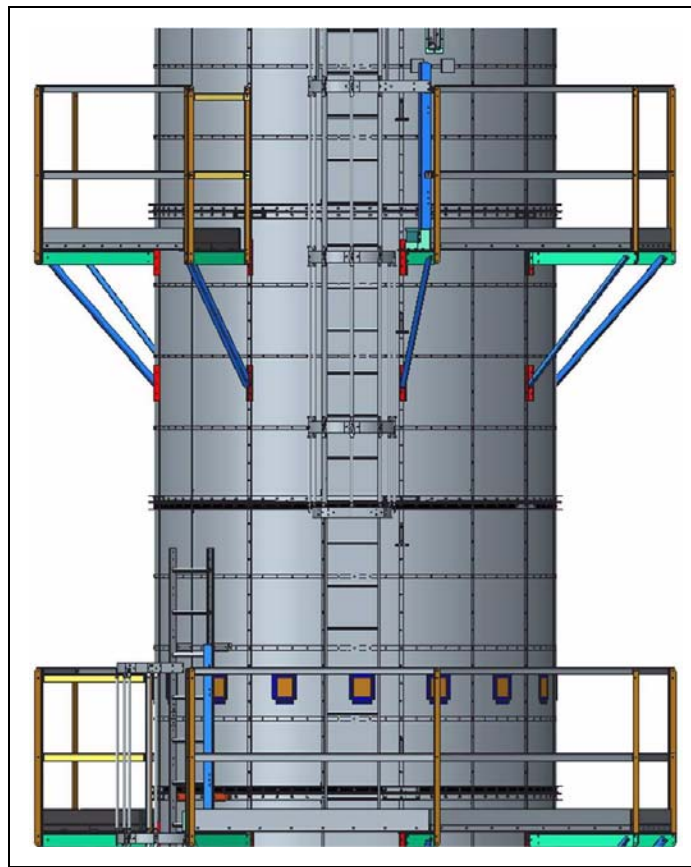

Figure 15J

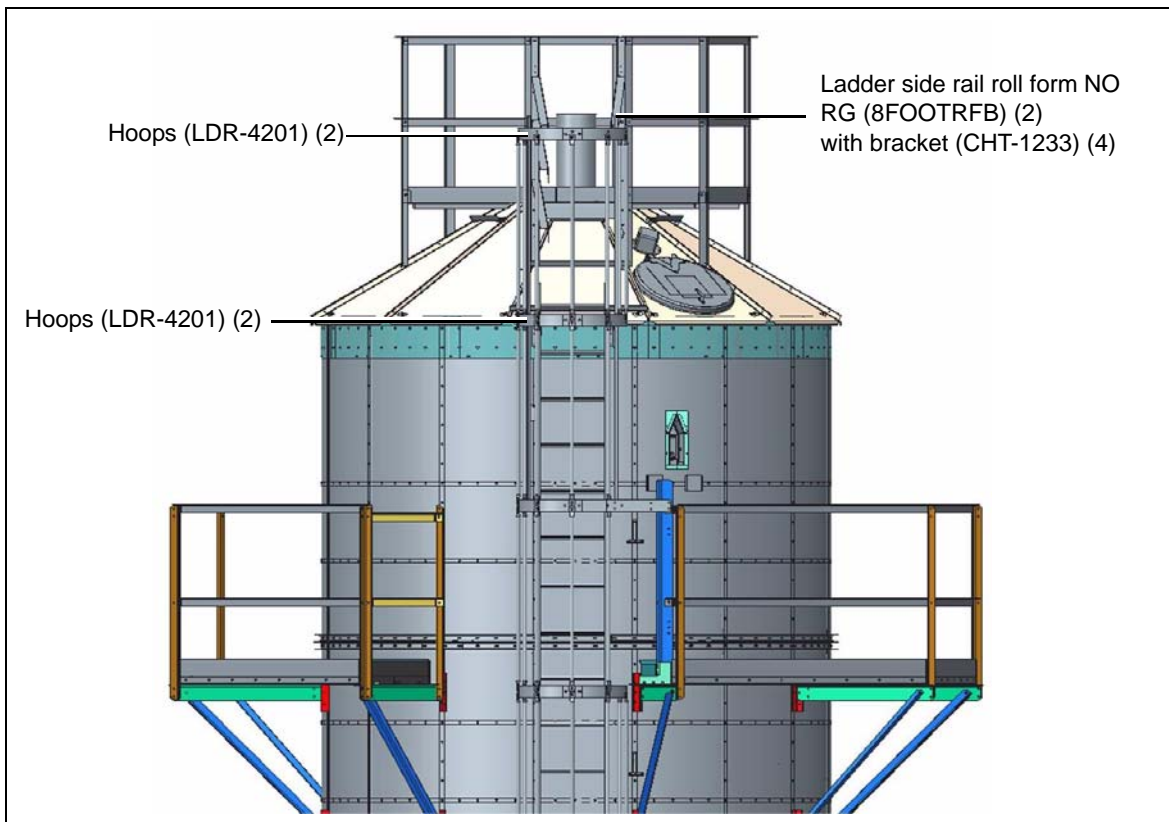

Figure 15K

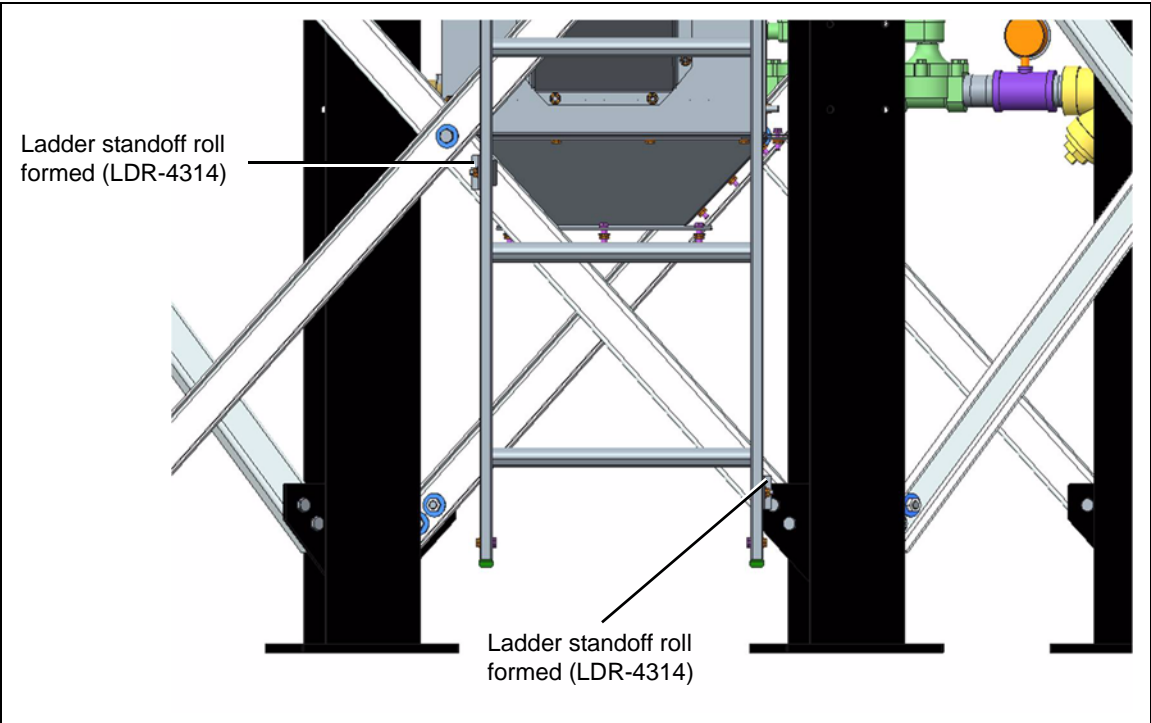

Figure 15L

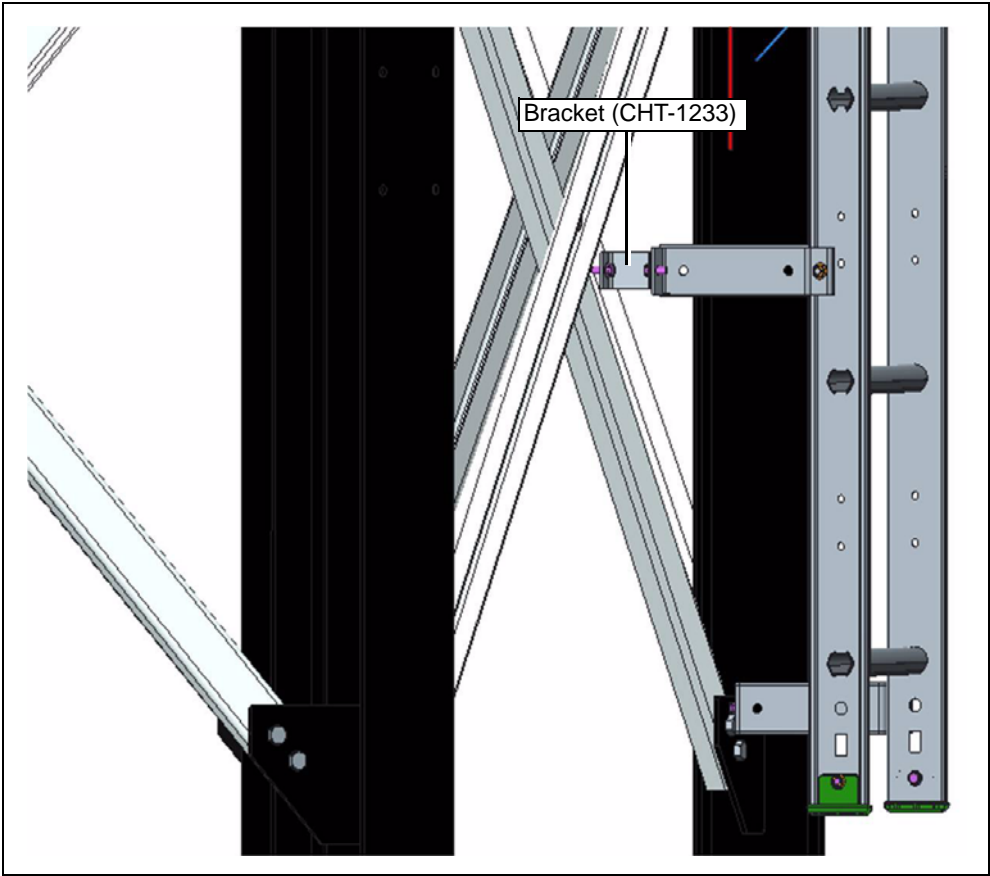

Figure 15M



Figure 15N

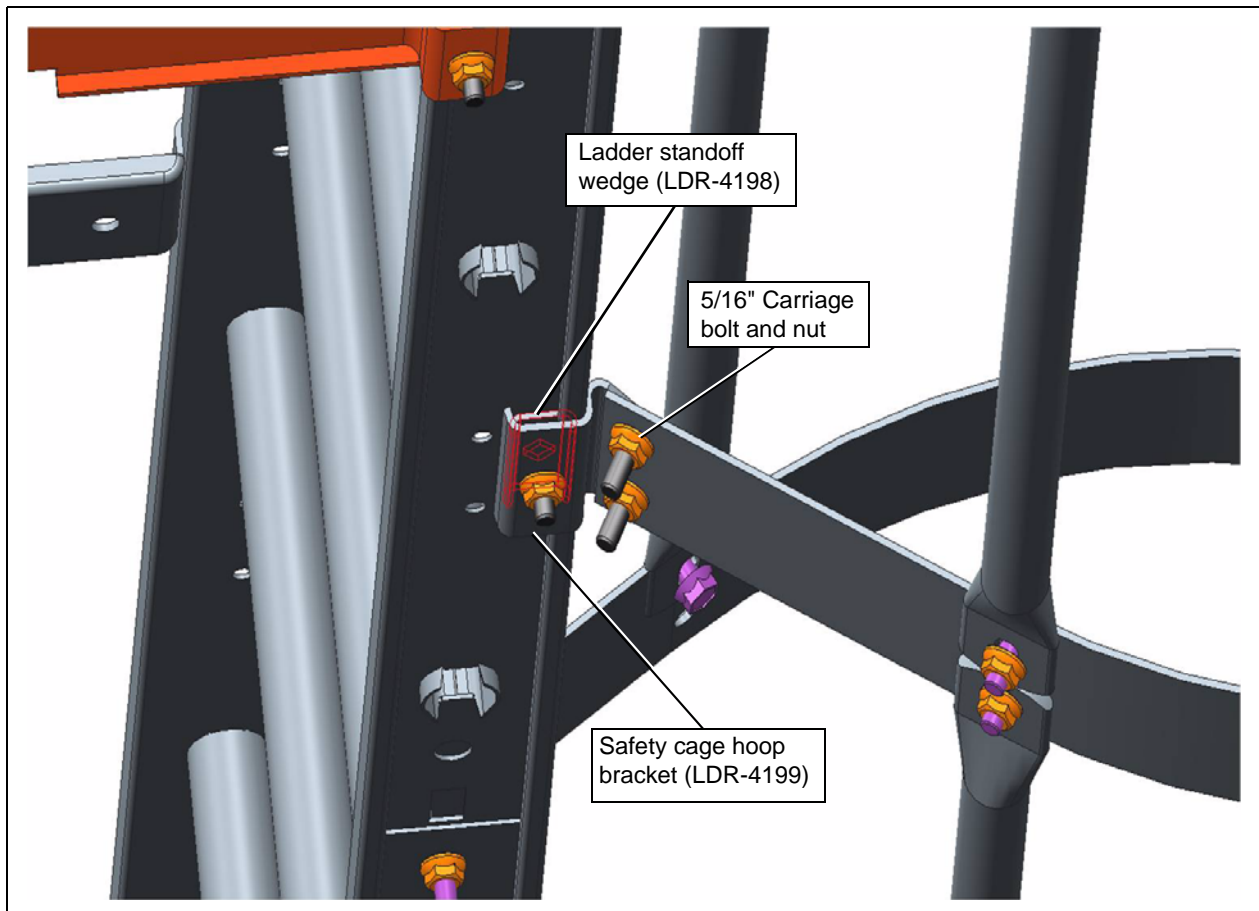

Figure 15O

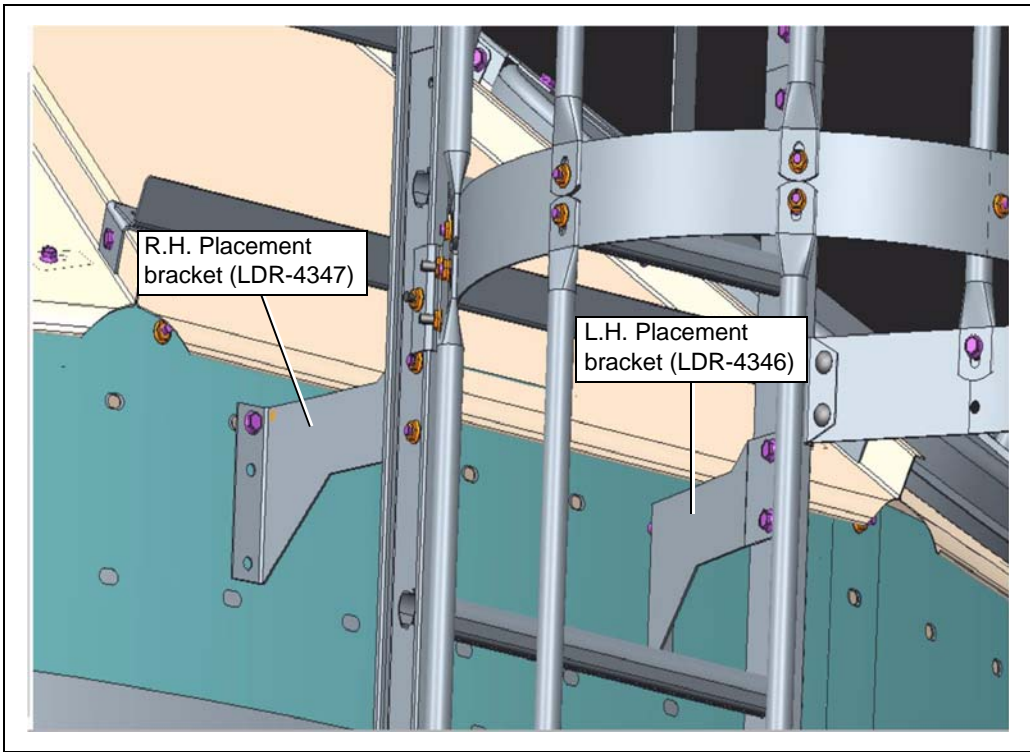

Figure 15P

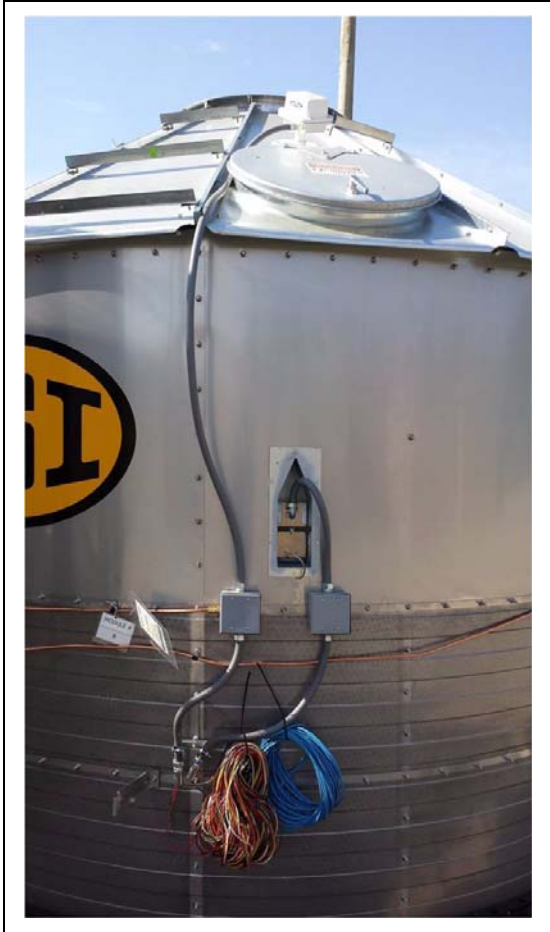

Figure 15Q

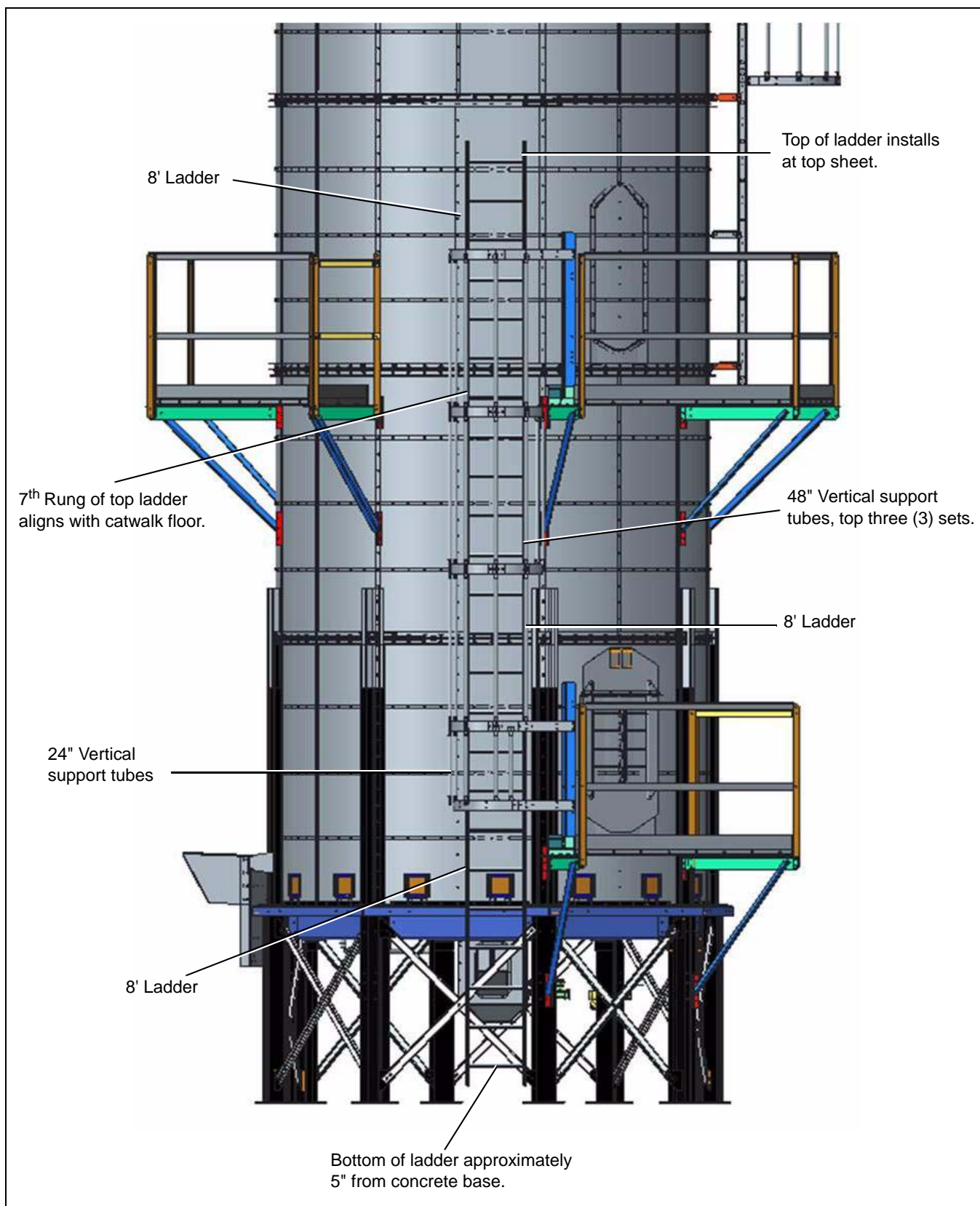

Figure 16A

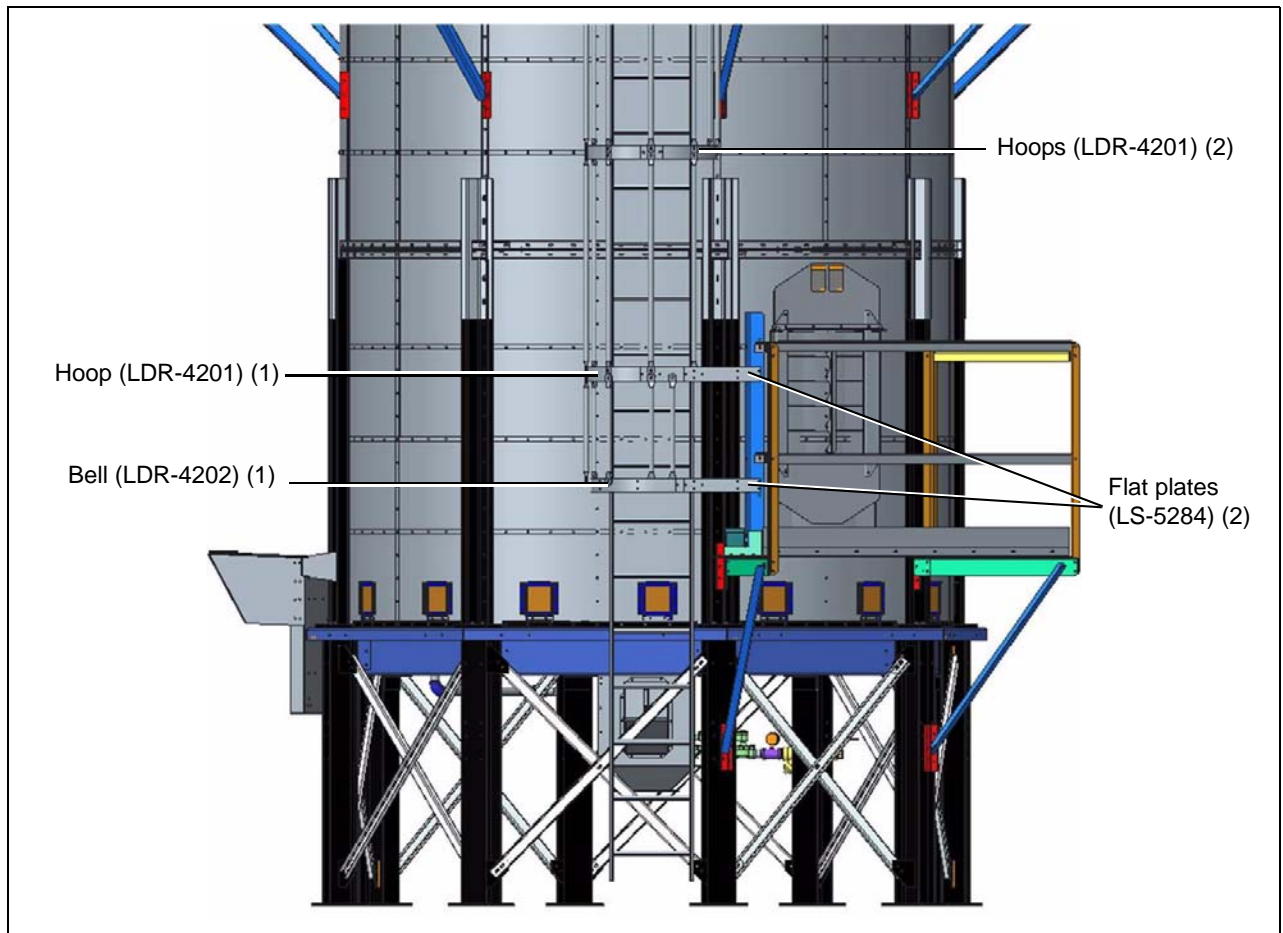

Figure 16B

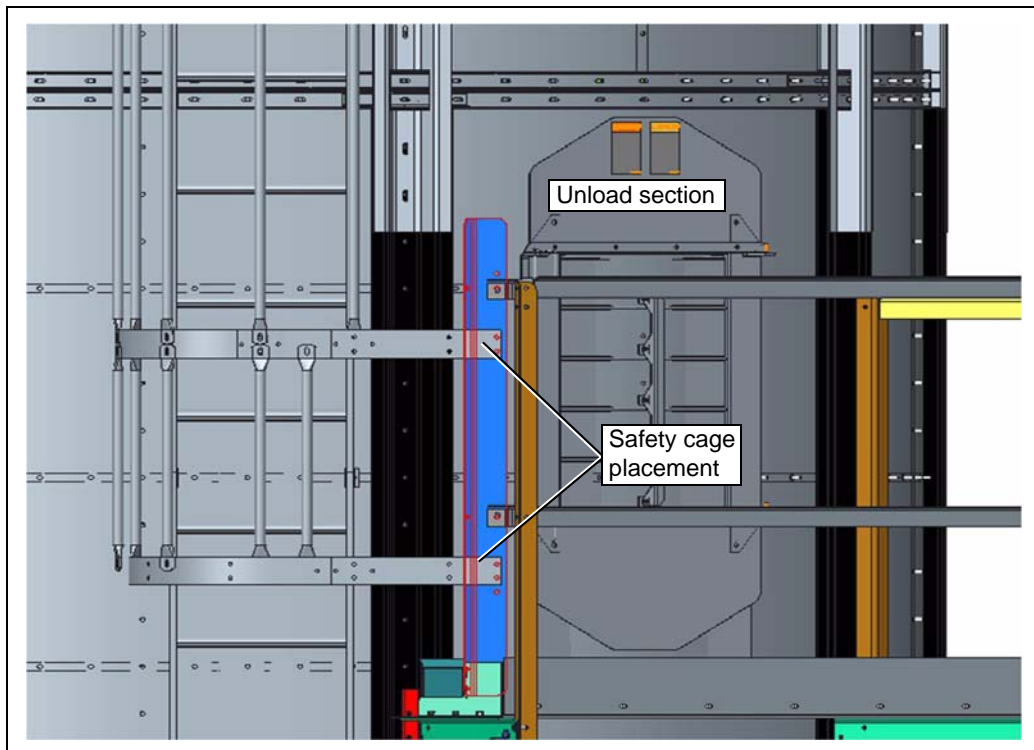

Figure 16C

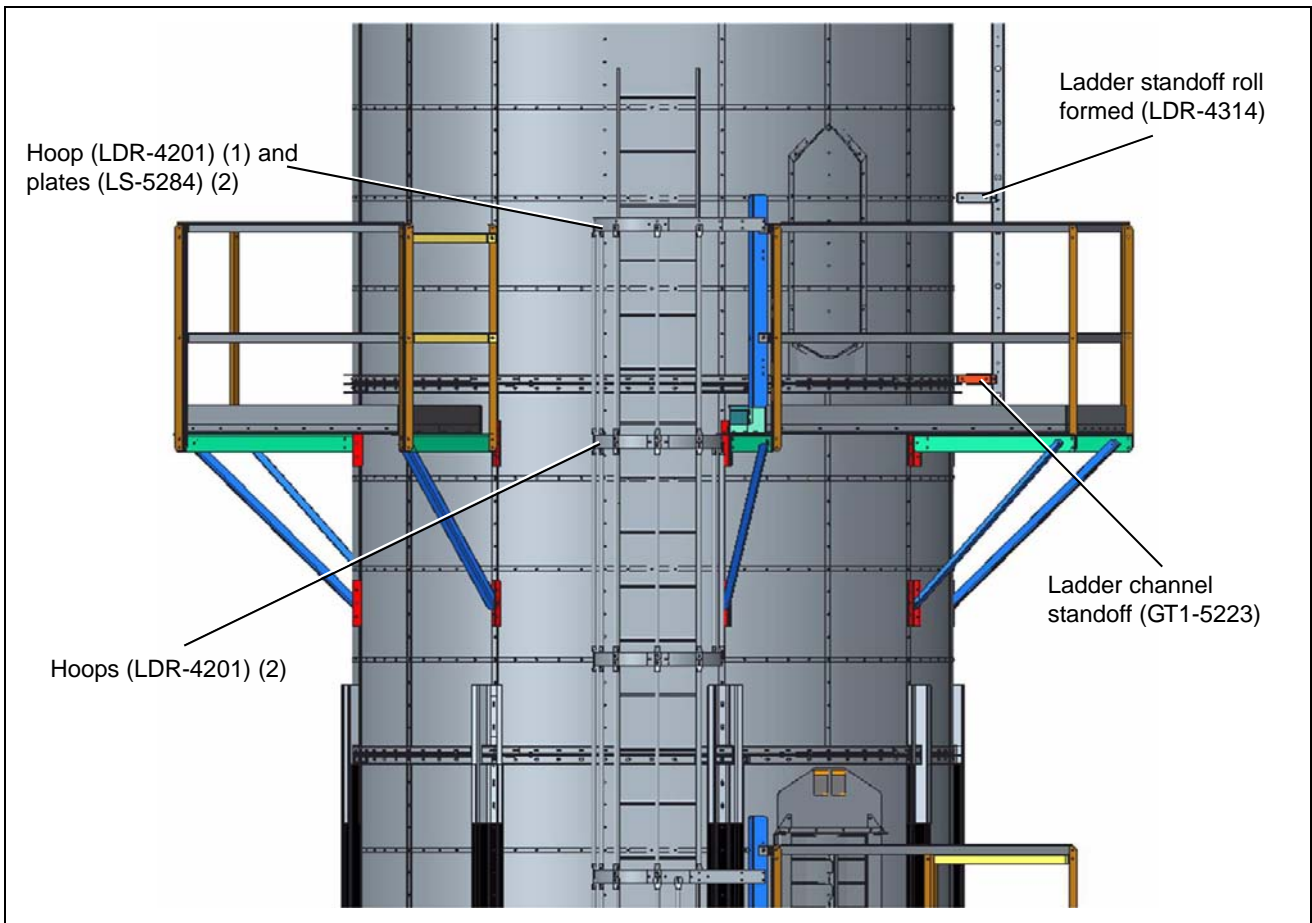

Figure 16D

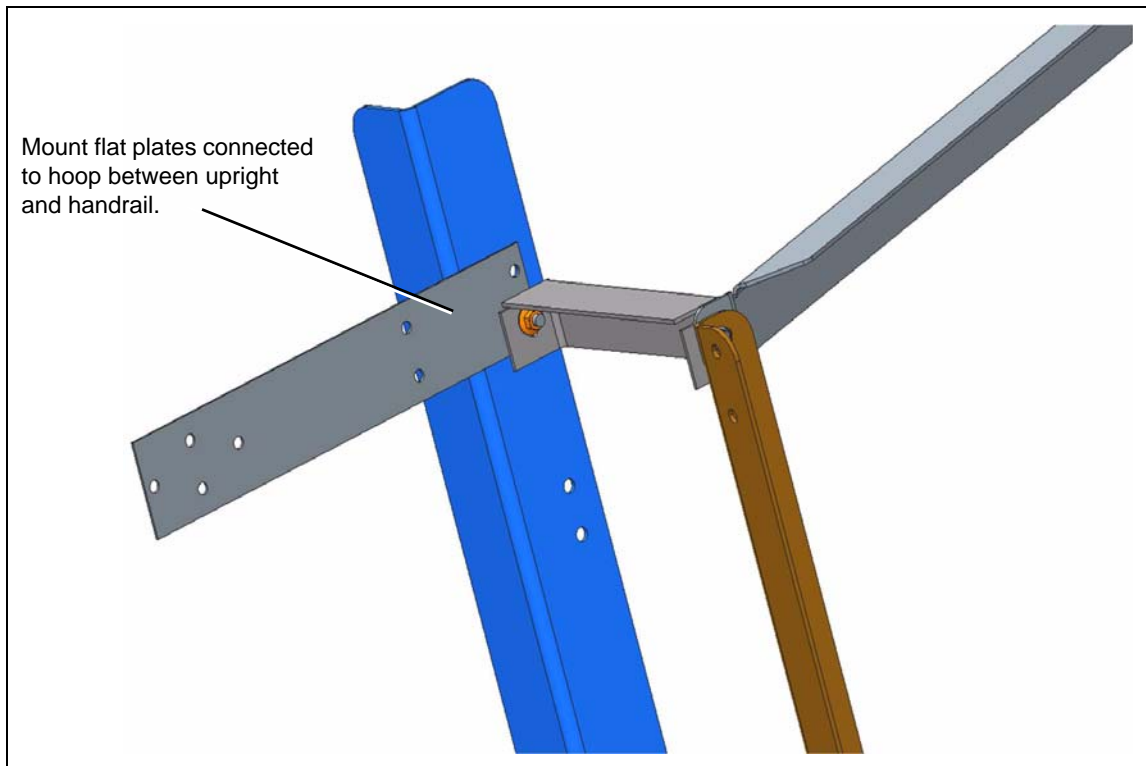

Figure 16E

16. Appendix D - TM-1015 Ladders

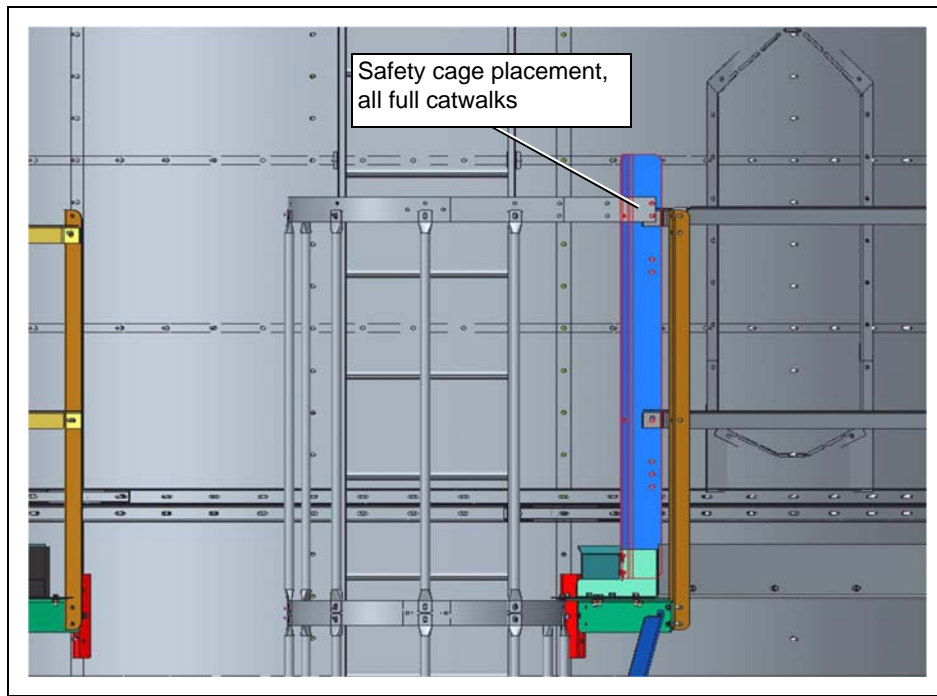

Figure 16F

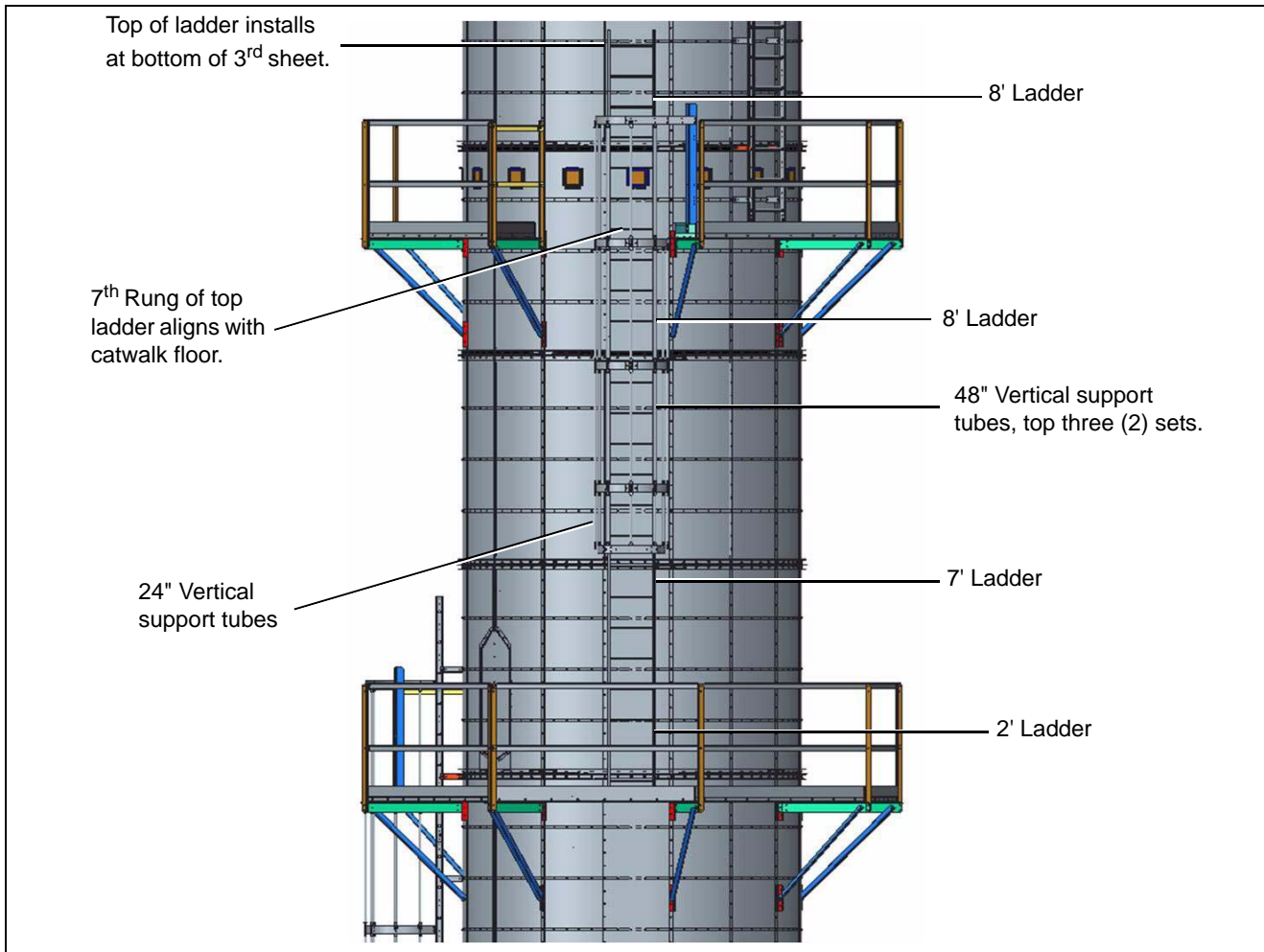

Figure 16G

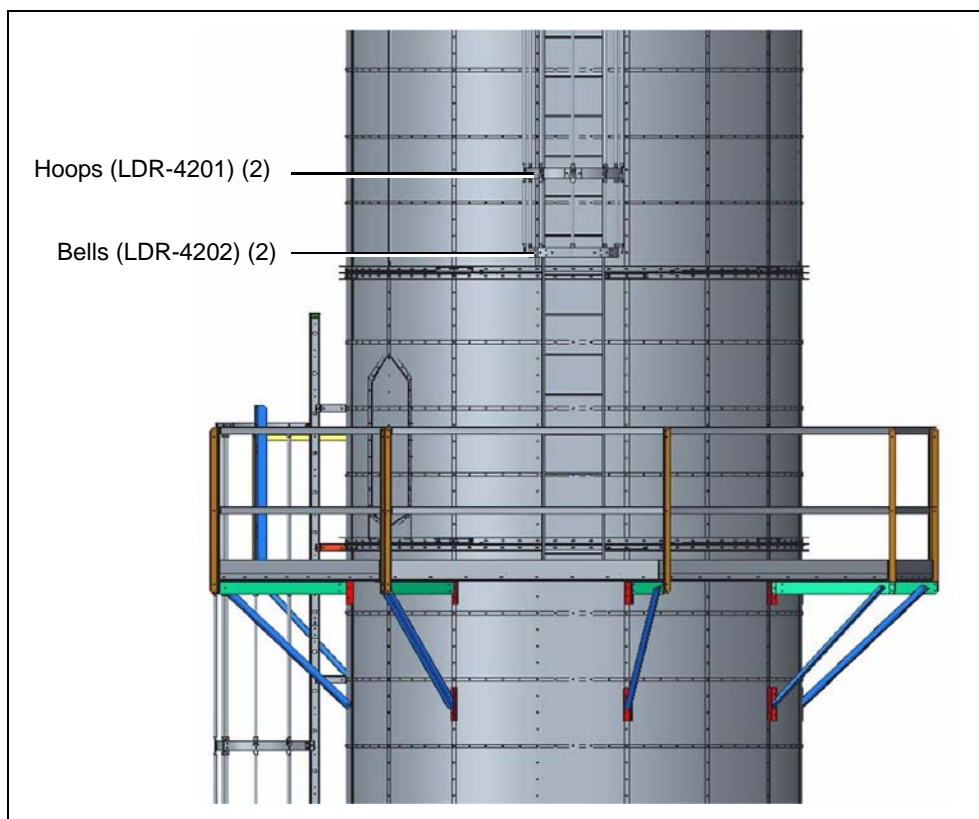

Figure 16H

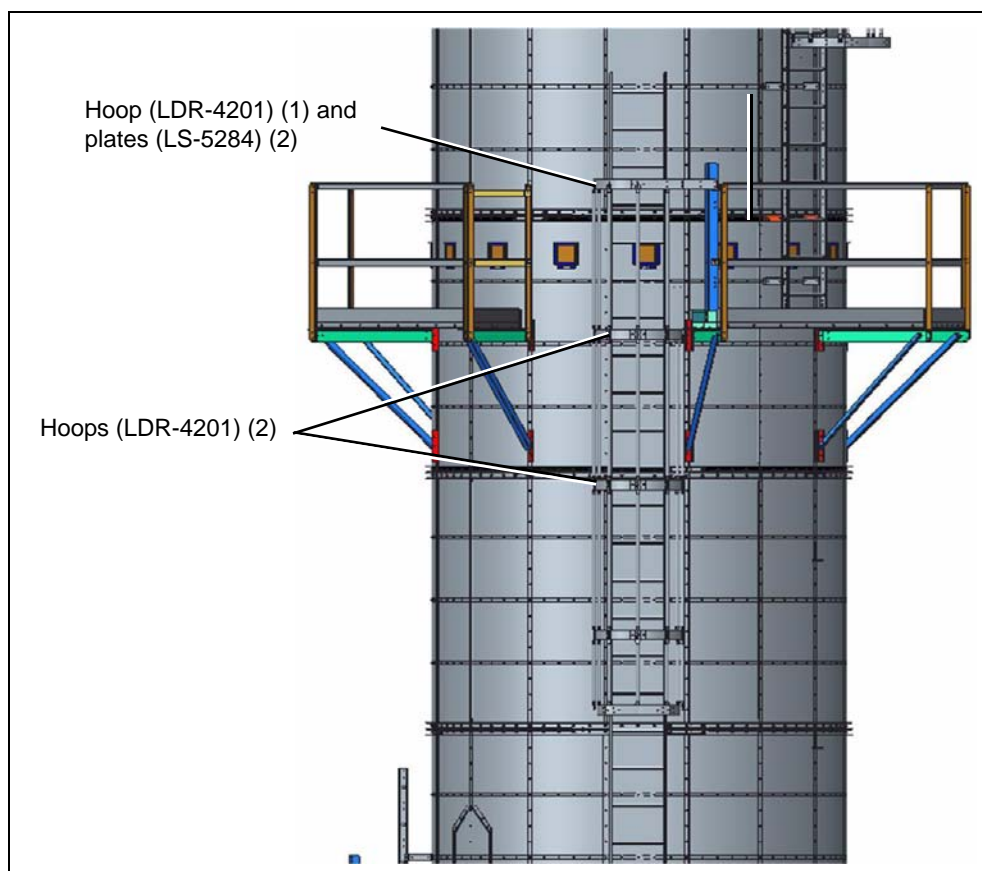

Figure 16I

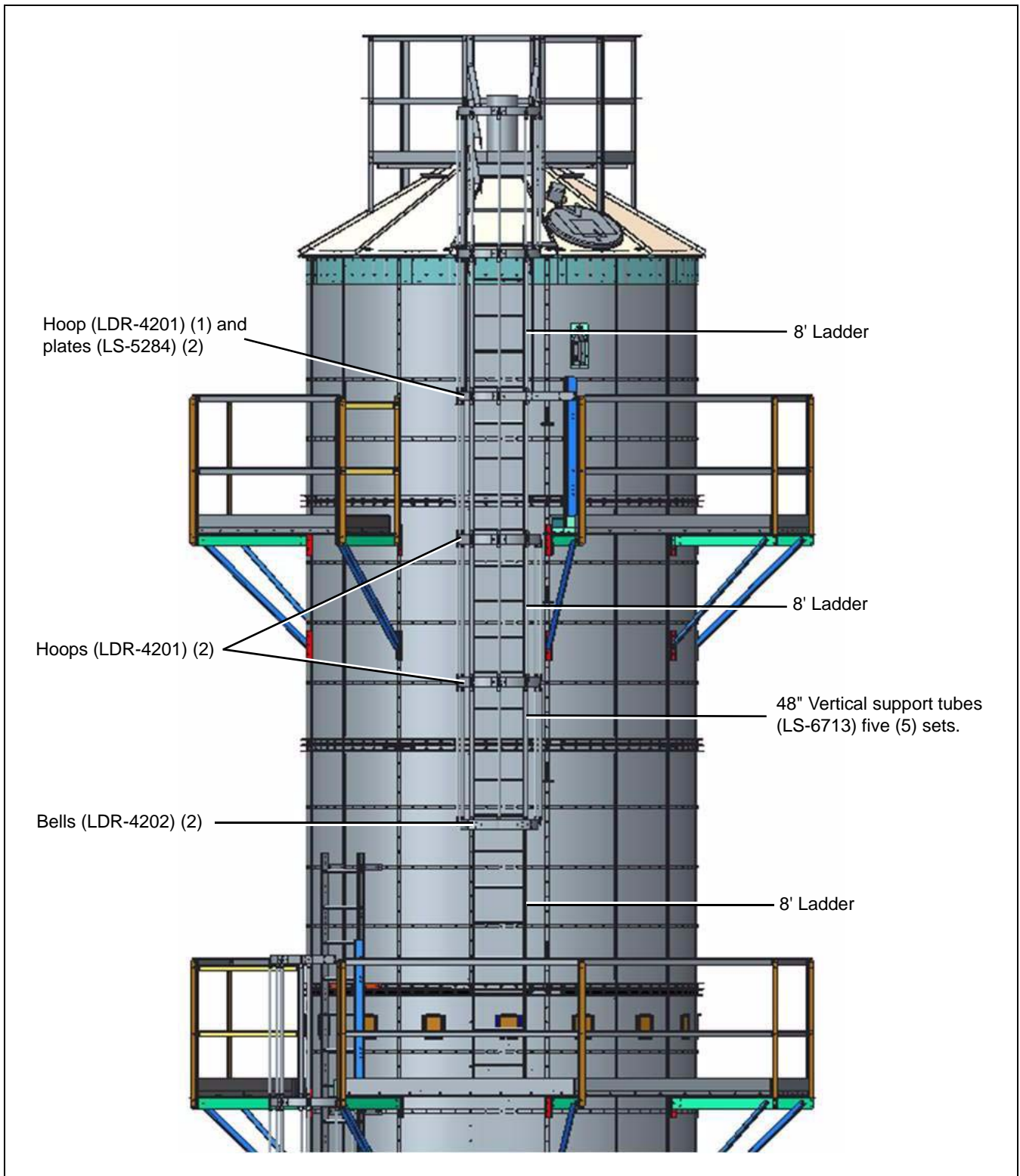

Figure 16J

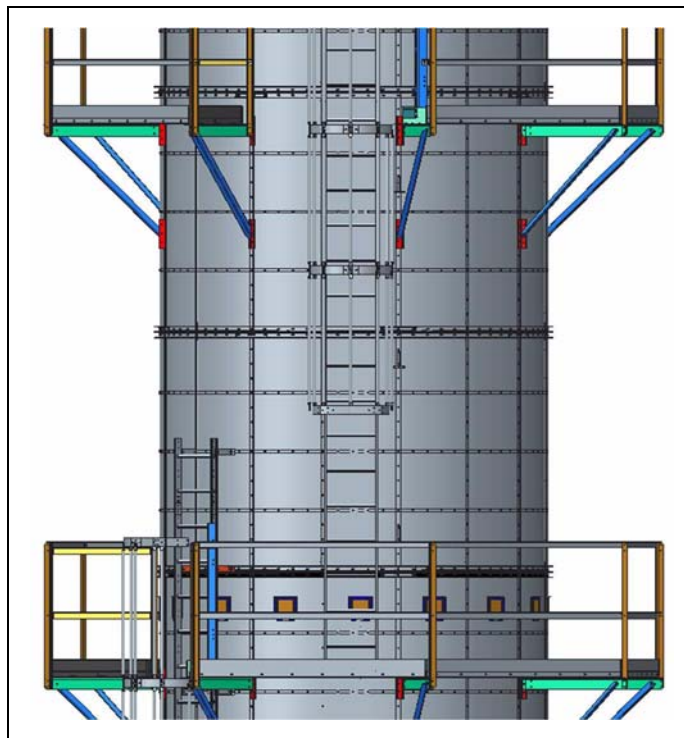

Figure 16K

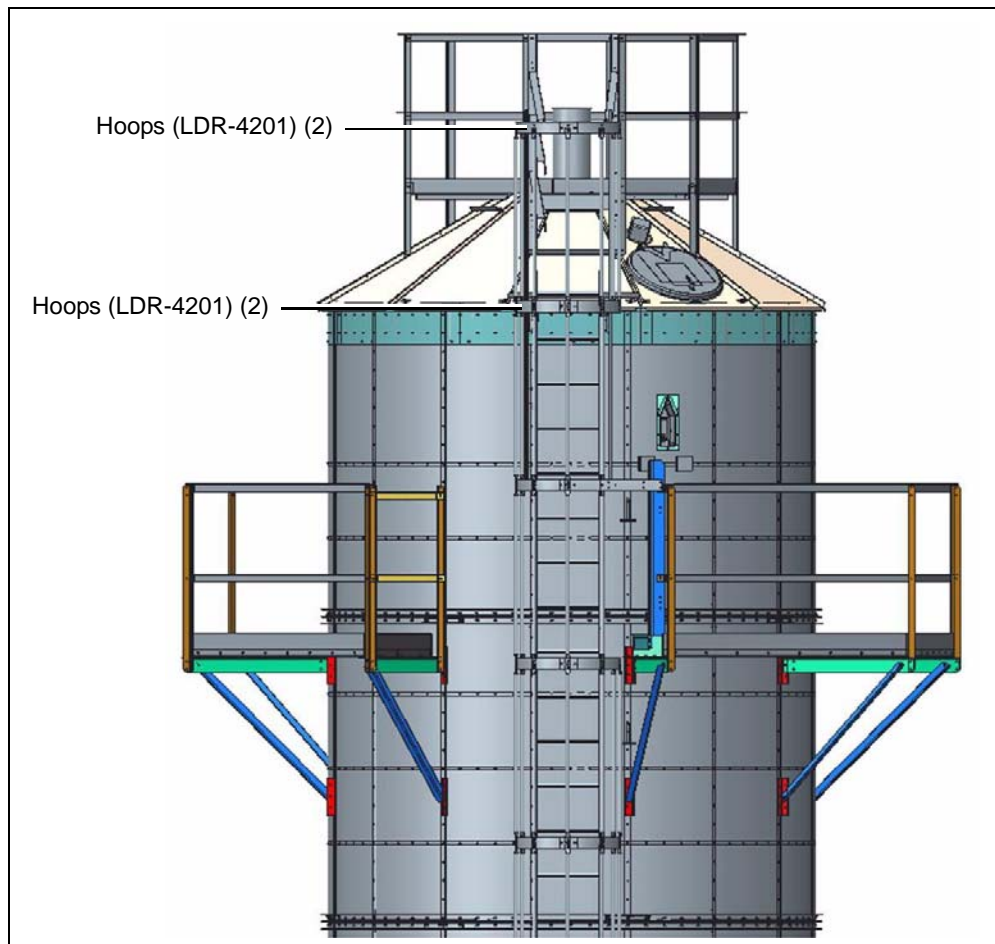

Figure 16L

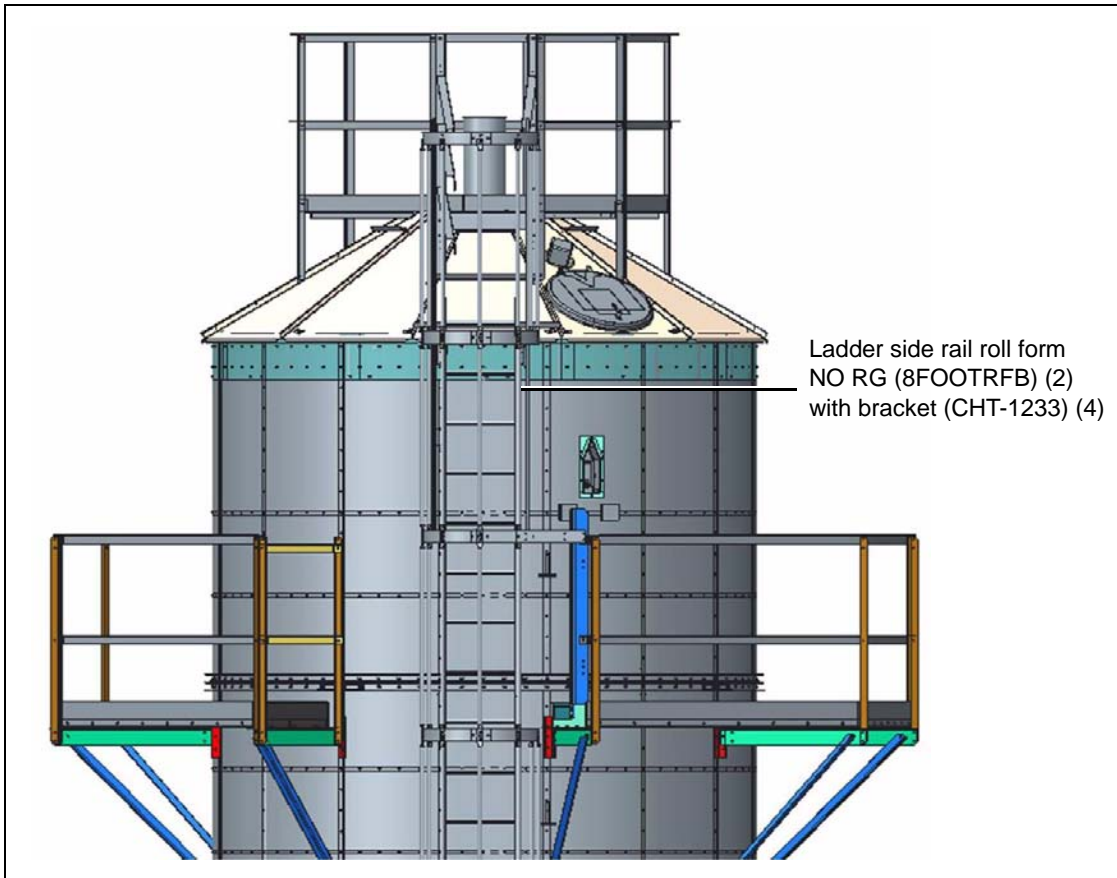

Figure 16M

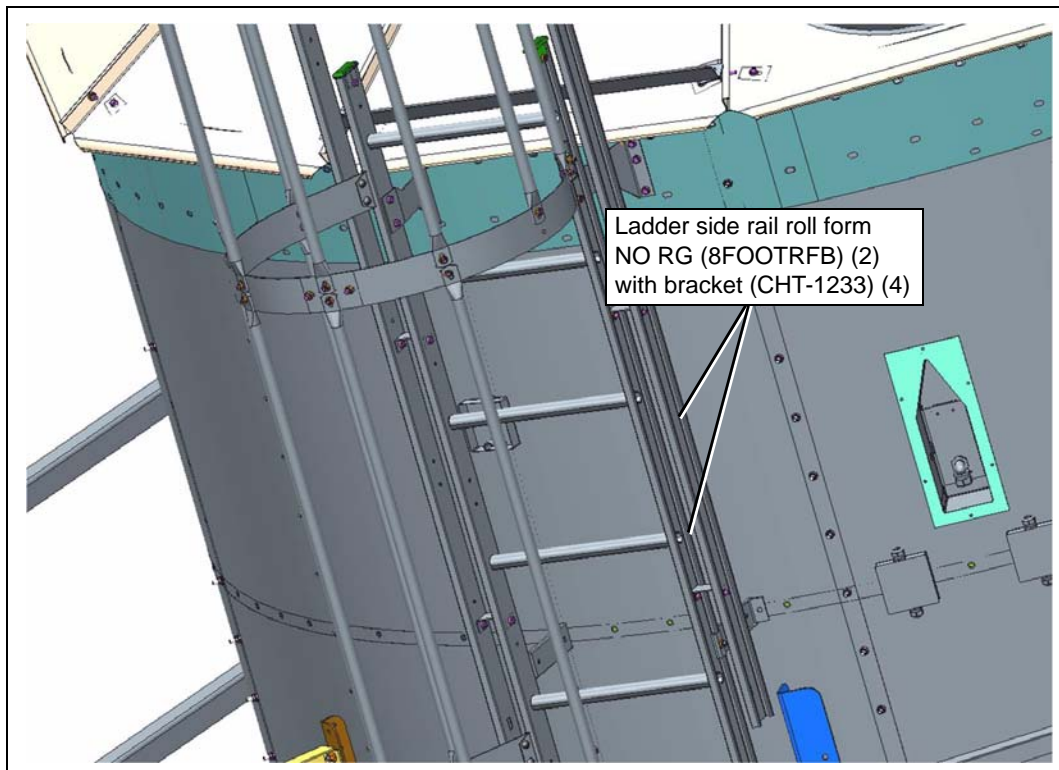

Figure 16N



Figure 16O

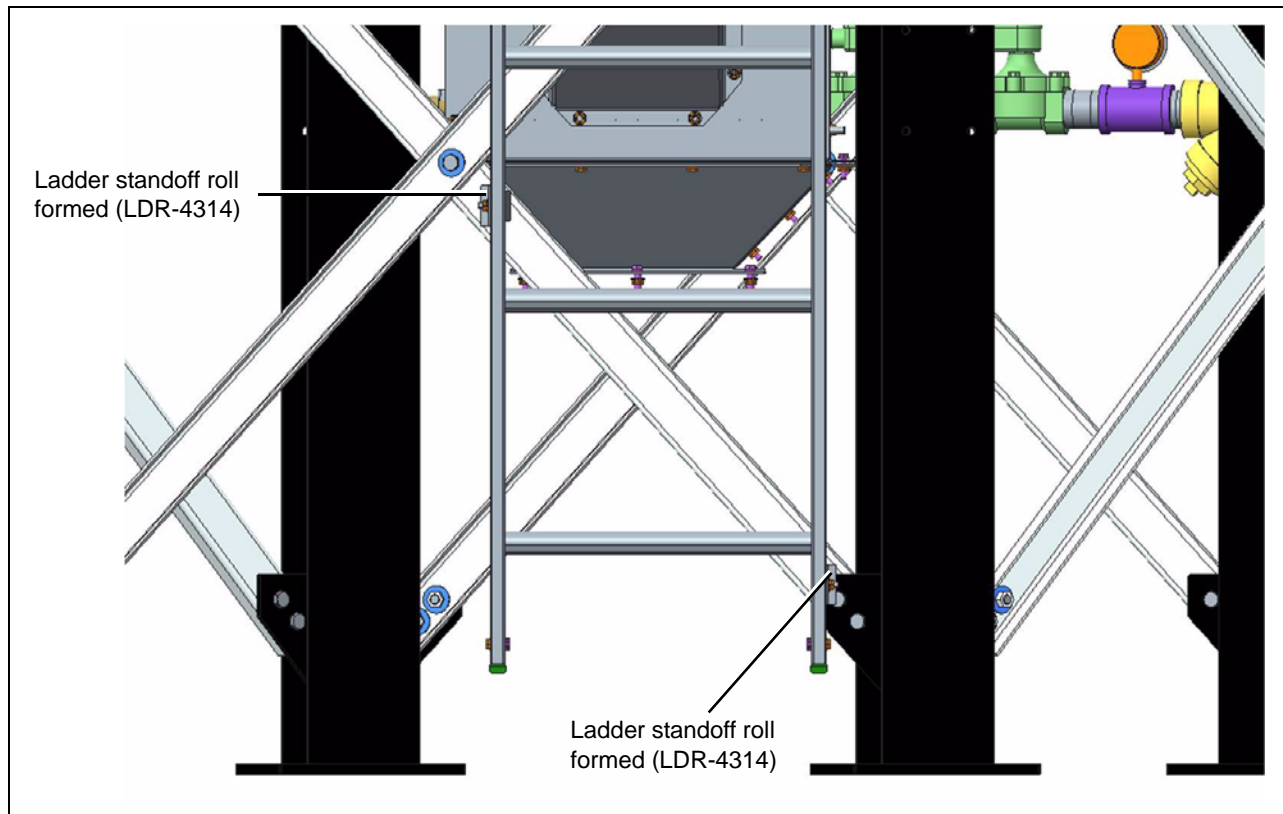

Figure 16P

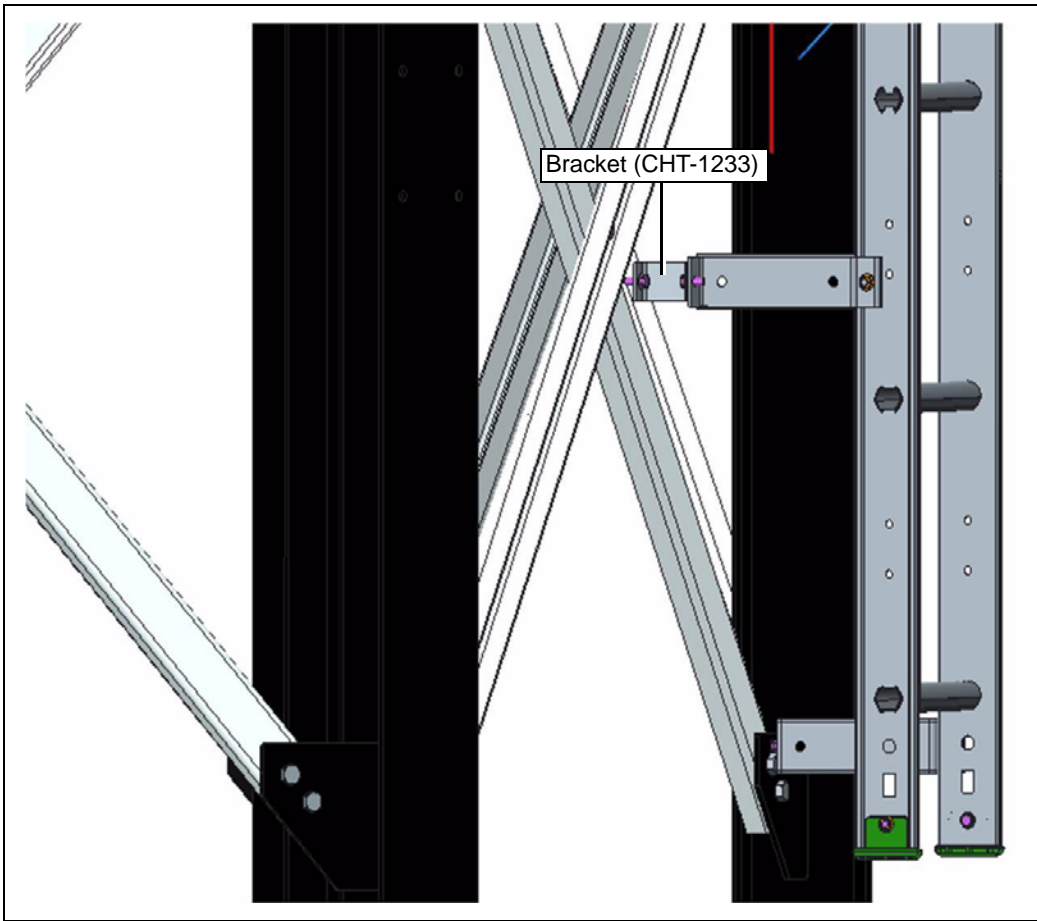

Figure 16Q

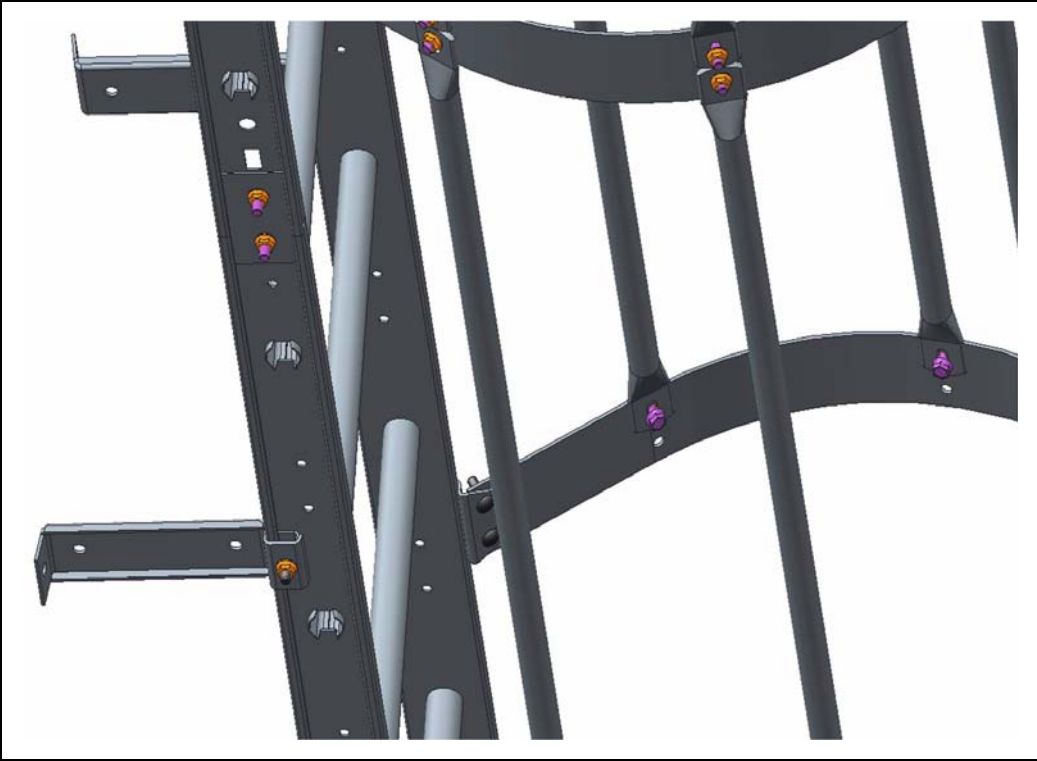

Figure 16R

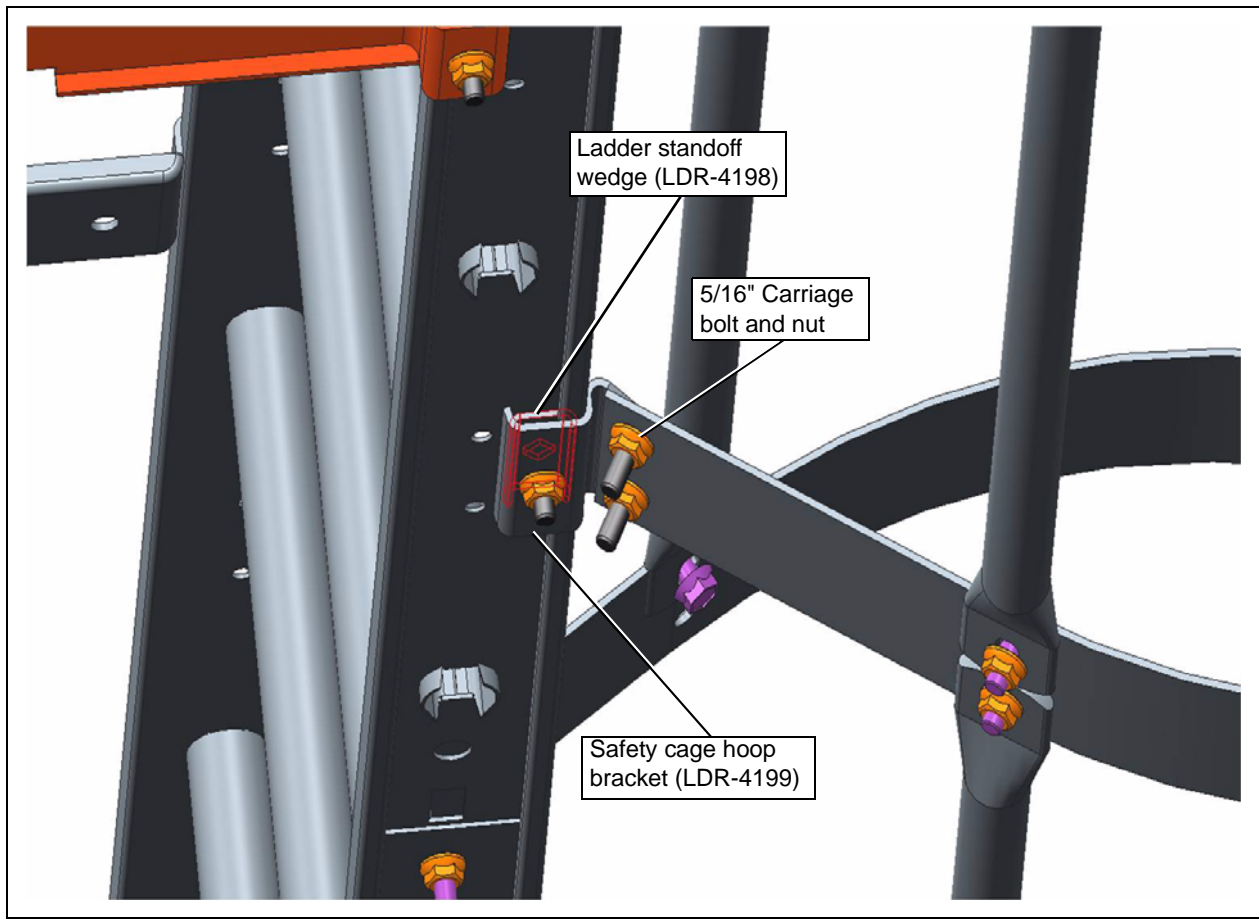

Figure 16S

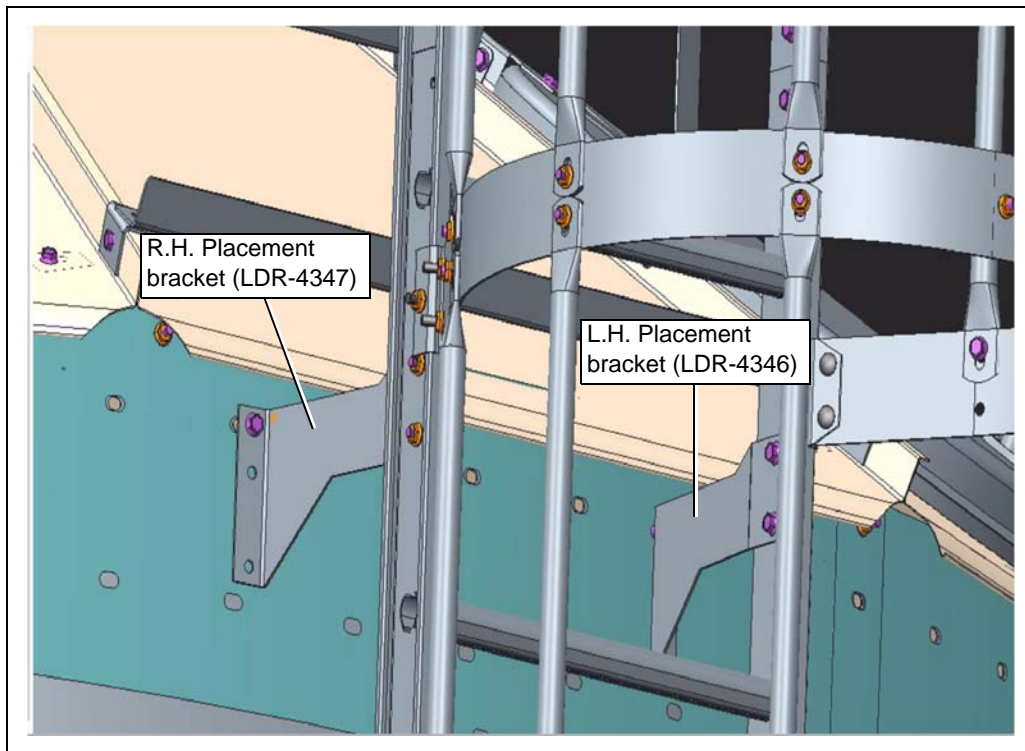

Figure 16T

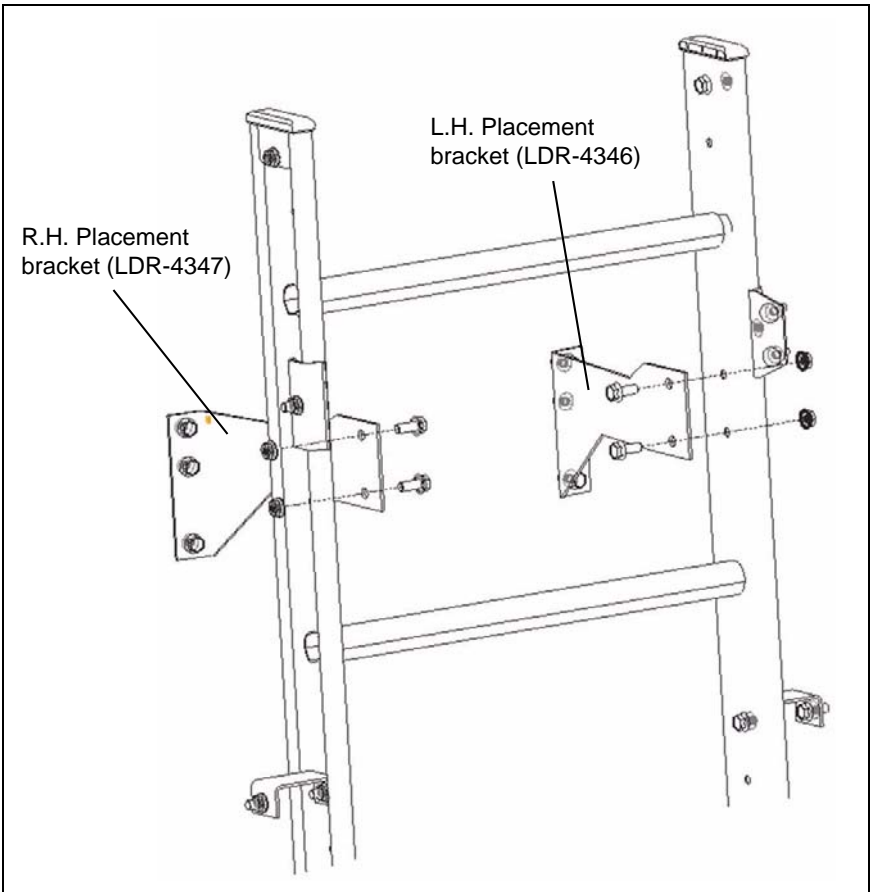

Figure 16U



Figure 16V



Figure 16W



Figure 16X



Figure 16Y



Figure 16Z

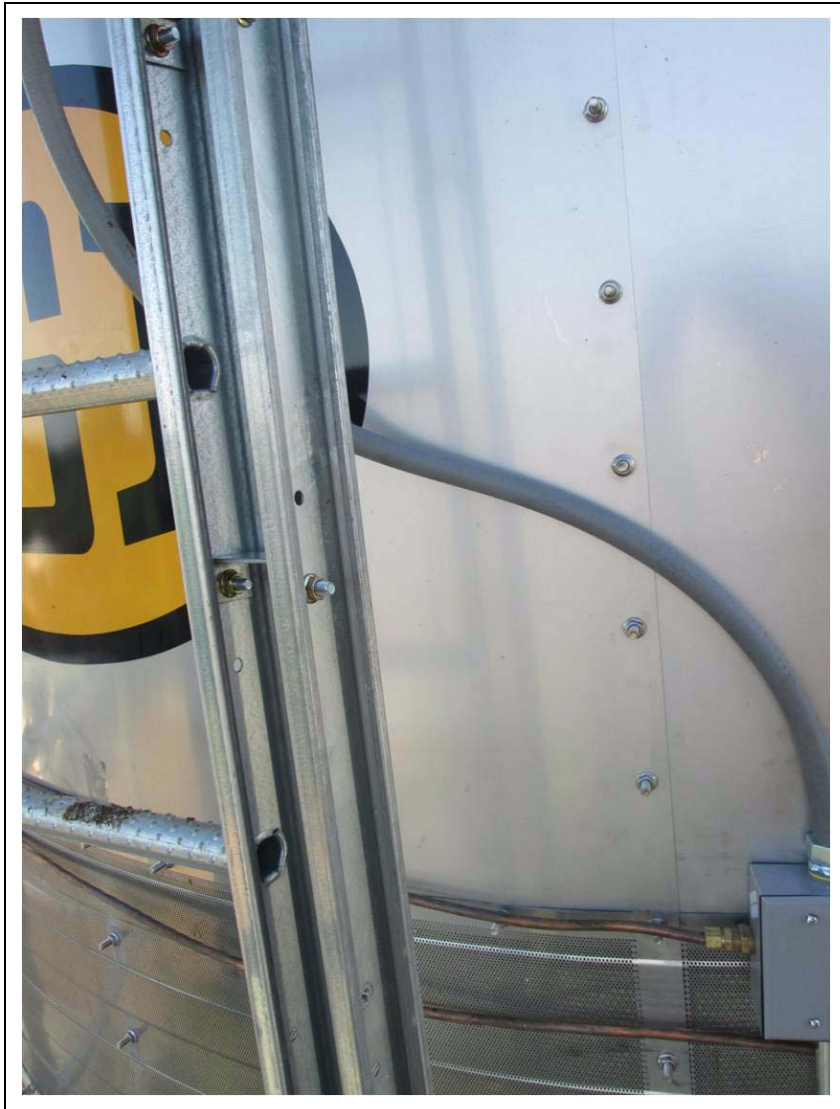

Figure 16AA

17. Appendix E - Peak Walk Around Onsite Install Parts

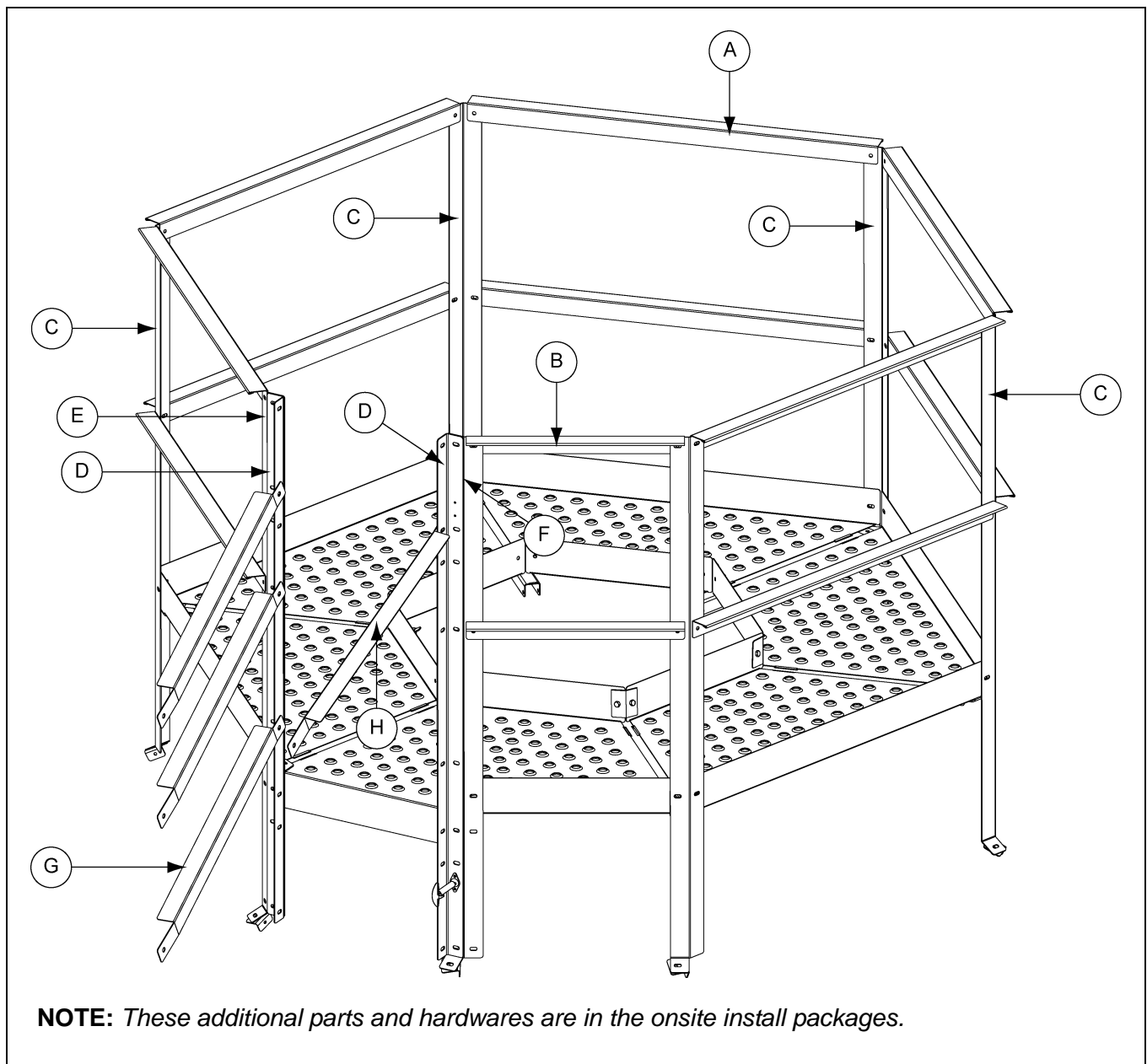

Figure 17A

Ref #	Part #	Description	Qty
A	GT1-5137	Handrail, Roof Top Walk Around, Long	5
B	GT1-5145	Handrail, Roof Top Walk Around, Short	1
C	GT1-5749	Support, Upper Peak Walk Around	4
D	GT1-5750	Support, 60/30 Upper Peak Walk Around	2
E	GT1-5751	Angle, Upper Peak Walk Around Entry	2
F	GT1-5752	Support, 30/30 Upper Peak Walk Around	1
G	GT1-5131	Support, Transition	3
H	GT1-5132	Support, Transition	1

Limited Warranty — N.A. Grain Products

The GSI Group, LLC. ("GSI") warrants products which it manufactures, to be free of defects in materials and workmanship under normal usage and conditions for a period of 12 months from the date of shipment (or, if shipped by vessel, 14 months from the date of arrival at the port of discharge). If, in GSI's sole judgment, a product is found to have a defect in materials and/or workmanship, GSI will, at its own option and expense, repair or replace the product or refund the purchase price. This Limited Warranty is subject to extension and other terms as set forth below.

Warranty Enhancements: The warranty period for the following products is enhanced as shown below and is in lieu of (and not in addition to) the above stated warranty period. (Warranty Period is from date of shipment.)

	Product	Warranty Period
Storage	Grain Bin Structural Design • Sidewall, roof, doors, platforms and walkarounds • Flooring (when installed using GSI specified floor support system for that floor) • Hopper tanks (BFT, GHT, NCHT, and FCHT)	5 Years
Conditioning	Dryer Structural Design – (Tower, Portable and TopDry) • Includes (frame, portable dryer screens, ladders, access doors and platforms)	5 Years
	All other Dryer parts including: • Electrical (controls, sensors, switches and internal wiring)	2 Years
	All Non-PTO Driven Centrifugal and Axial Fans	3 Years
	Bullseye Controllers	2 Years
Material Handling	Bucket Elevators Structural Design	5 Years
	Towers Structural Design	5 Years
	Catwalks Structural Design	5 Years
	Accessories (stairs, ladders and platforms) Structural Design	5 Years

Conditions and Limitations:

THERE ARE NO WARRANTIES THAT EXTEND BEYOND THE LIMITED WARRANTY DESCRIPTION SET FORTH HEREIN; SPECIFICALLY, GSI DISCLAIMS ANY AND ALL OTHER WARRANTIES OF ANY KIND, EXPRESS OR IMPLIED, INCLUDING, WITHOUT LIMITATION, WARRANTIES OF MERCHANTABILITY OR FITNESS FOR A PARTICULAR PURPOSE OR USE IN CONNECTION WITH: (I) ANY PRODUCT MANUFACTURED OR SOLD BY GSI, OR (II) ANY ADVICE, INSTRUCTION, RECOMMENDATION OR SUGGESTION PROVIDED BY AN AGENT, REPRESENTATIVE OR EMPLOYEE OF GSI REGARDING OR RELATED TO THE CONFIGURATION, INSTALLATION, LAYOUT, SUITABILITY FOR A PARTICULAR PURPOSE, OR DESIGN OF SUCH PRODUCTS.

The sole and exclusive remedy for any claimant is set forth in this Limited Warranty and shall not exceed the amount paid for the product purchased. This Warranty only covers the value of the warranted parts and equipment, and does not cover labor charges for removing or installing defective parts, shipping charges with respect to such parts, any applicable sales or other taxes, or any other charges or expenses not specified in this Warranty. GSI shall not be liable for any other direct, indirect, incidental or consequential damages, including, without limitation, loss of anticipated profits or benefits. Expenses incurred by or on behalf of a claimant without prior written authorization from the GSI warranty department shall not be reimbursed. This warranty is not transferable and applies only to the original end-user. GSI shall have no obligation or responsibility for any representations or warranties made by or on behalf of any dealer, agent or distributor. Prior to installation, the end-user bears all responsibility to comply with federal, state and local codes which apply to the location and installation of the products.

This Limited Warranty extends solely to products sold by GSI and does not cover any parts, components or materials used in conjunction with the product, that are not sold by GSI. GSI assumes no responsibility for claims resulting from construction defects, unauthorized modifications, corrosion or other cosmetic issues caused by storage, application or environmental conditions. Modifications to products not specifically delineated in the manual accompanying the product at initial sale will void all warranties. This Limited Warranty shall not extend to products or parts which have been damaged by negligent use, misuse, alteration, accident or which have been improperly/inadequately maintained.

Notice Procedure:

In order to make a valid warranty claim a written notice of the claim must be submitted, using the RMA form, within 60 days of discovery of a warrantable nonconformance. The RMA form is found on the OneGSI portal.

Service Parts:

GSI warrants, subject to all other conditions described in this Warranty, Service Parts which it manufactures for a period of 12 months from the date of purchase unless specified in Enhancements above.

This equipment shall be installed in accordance with the current installation codes and applicable regulations, which should be carefully followed in all cases. Authorities having jurisdiction should be consulted before installations are made.



**1004 E. Illinois St.
Assumption, IL 62510-0020
Phone: 1-217-226-4421
Fax: 1-217-226-4420
www.gsiag.com**



GSI is a worldwide brand of AGCO Corporation.