



CE Approved PLC Tower Dryers

Operators Manual

PNEG-1796CE

Version: 2.2

Date: 06-17-16



PNEG-1796CE

This product is protected under one or more of the following U.S. patents:

6233843, 6189235, 6141886, 6101742, 6098305, 6088929, 6076276, 6073367, 6073364, 5570521, 6457256, 6035544, 5860221, 5653043, 5651193, 5604996, 5566470, 5400525

	CE Declaration MACHINERY DIRECTIVE 2006/42/EC
1004 East Illinois Street, Assumption, IL, 62510, USA +1 217 226 4429	

We, the GSI Group LLC, declare that

GSI Tower Dryers and Zimmerman Tower Dryers

With the following model numbers

***** 3 L T E *****
***** 6 L T E *****
***** 3 N T E *****
***** 6 N T E *****
***** 3 L M E *****
***** 6 L M E *****
***** 3 N M E *****
***** 6 N M E *****

Meet the Essential Requirements of the Machinery Directive 2006/42/EC and has been constructed to using the following standards:

- EN746-2:1996 *Industrial Thermo Processing Equipment.*
- EN298:2003 *Automatic gas burner control systems for gas burners and gas burning appliances with or without fans.*
- EN 161:2008 *Automatic shut off valves for gas burners and gas appliances.*
- ISO 14121-1 *Safety of machinery - Risk assessment.*

We further declare that the above machines also fulfill the requirements of the Electromagnetic Compatibility Directive (EMC) 2004/108/EC being tested and certified under the following standards by EU Notified Body Intertek Testing Service Inc:

- EN61000-6-2 *Generic standards - Immunity for industrial environments.*
- EN61000-6-4 *Generic standards - Emission standard for industrial environments.*

These declarations apply solely to the equipment as supplied by GSI and described in the attached manual. It does not imply compliance for any equipment connected to or associated with the dryer, modifications of any sort made to the dryer, nor for any electrical, fuel or other energy supplies connected to the incoming terminations on the dryer.

GSI GROUP



**CE Declaration
MACHINERY DIRECTIVE
2006/42/EC**

1004 East Illinois Street, Assumption, IL, 62510, USA

+1 217 226 4429

The equipment above must not be put into service until the machinery into which it is to be incorporated has been declared in conformity with the provisions for all relevant Directives, or until these components have been assembled in the manner recommended in the attached manufacturers instructions.

Signed:

F. Q. Ward

Tower Dryer Gas Train Commissioning Check List and Sign-Off

Component	Set Point	Function Pass/Fail/NA
Check Fuel Supply Shut Off Valve		
Check Main Fuel Supply Pressure		
Set/Test Main Gas Regulator Pressure		
Set/Test Over Pressure Shut Off (OPSO) Pressure		
Set/Test Pressure Relief Valve		
Set/Test Maximum Gas Pressure Switch		
Set/Test Minimum Gas Pressure Switch		
Set Pilot Burner Pressure		
Set Burner High Flame Pressure		
Set Burner Low Flame Pressure		
Test Pilot Line Manual Shut Off Valve		
Test Main Gas Manual Shut Off Valve		
Set/Test Plenum High-Limit		
Carry Out Leak Test		
Check Purge Time		
Check Pilot Ignition		
Check Main Flame Ignition		
Check Modulating Valve Operation		
Check Burner Shut Down		

Name: _____ Signed: _____ Date: _____

Contents

Chapter 1 Safety	6
Safety Guidelines	6
Cautionary Symbols Definitions	7
Safety Cautions	8
Safety Sign-Off Sheet	14
Safety Precautions	15
Precautions to Reduce Risk of Fire	15
Chapter 2 Decals	16
Chapter 3 Installation Requirements	22
Electrical	22
Tower Dryer Minimum Power Requirements	22
Fuel	23
Tower Dryer Pipe Train Assembly	25
Inlet Section	26
Regulator Section	27
Pilot Section	28
Safety Shut Off Section	29
Modulator Section	30
PLC Dryer Control Panel	31
Chapter 4 Dryer Commissioning	33
Electrical	33
Gas Train	33
Chapter 5 Dryer Operation	37
Start-Up	37
Shut Down	41
Viewing Temperature/Moisture History	41
Viewing Burner/Fuel Train Status	41
Viewing Grain Flow Status	41
Modifying the Bushel per Hour Factor	41
Chapter 6 Tri-Point Moisture Controller	43
Control Operation Principles	43
Set-Up Controller	44
Operation Procedure	45
Alarms	46
Access Drying History	46
Chapter 7 Maintenance	48
Pre-Season Inspection and Service	48
Mid Season Inspection and Service	49
In Case of Fire	50
End of Season Service	50
Lubrication Table	51
Chapter 8 Troubleshooting	52
Troubleshooting - Drying Issues	52
Troubleshooting - Burner	53
Troubleshooting - General	54
Troubleshooting - OIU (Screen) Messages	55
Chapter 9 Tower Dryer Control Panel Wiring Diagrams	58
Chapter 10 Warranty	89

Safety Guidelines

Safety guidelines are general-to-specific safety rules that must be followed at all times. This manual is written to help you understand safe operating procedures and problems that can be encountered by the operator and other personnel when using this equipment. Save these safety guidelines for future reference.

As owner or operator, you are responsible for understanding the requirements, hazards, and precautions that exist and to inform others as required. Unqualified persons must stay out of the work area at all times.

Alterations must not be made to the equipment. Alterations can produce dangerous situations resulting in **SERIOUS INJURY or DEATH**.

This equipment must be installed in accordance with the current installation codes and applicable regulations, which must be carefully followed in all cases. Authorities having jurisdiction must be consulted before installations are made.

When necessary, you must consider the installation location relative to electrical, fuel and water utilities.

Personnel operating or working around equipment must read this manual. This manual must be delivered with equipment to its owner. Failure to read this manual and its safety instructions is a misuse of the equipment.

ST-0001-3

Cautionary Symbols Definitions

Cautionary symbols appear in this manual and on product decals. The symbols alert the user of potential safety hazards, prohibited activities and mandatory actions. To help you recognize this information, we use the symbols that are defined below.



This symbol indicates an imminently hazardous situation which, if not avoided, **will result in serious injury or death.**



This symbol indicates a potentially hazardous situation which, if not avoided, **can result in serious injury or death.**



This symbol indicates a potentially hazardous situation which, if not avoided, **can result in minor or moderate injury.**



This symbol is used to address practices not related to personal injury.



This symbol indicates a general hazard.



This symbol indicates a prohibited activity.

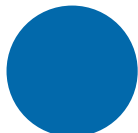

This symbol indicates a mandatory action.

ST-0005-2

1. Safety

Safety Cautions

Use Personal Protective Equipment

- Use appropriate personal protective equipment:

Eye Protection



Respiratory Protection



Foot Protection



Hearing Protection



Head Protection



Fall Protection



Hand Protection



- Wear clothing appropriate to the job.
- Remove all jewelry.
- Tie long hair up and back.

ST-0004-1

Follow Safety Instructions

- Warning: If the information in the manual is not followed exactly, a fire or explosion can result, causing property damage, personal injury or loss of life.
- Carefully read all safety messages in this manual and safety signs on your machine. Keep signs in good condition. Replace missing or damaged safety signs. Be sure new equipment components and repair parts include the current safety signs. Replacement safety signs are available from the manufacturer.
- Learn how to operate the machine and how to use controls properly. Do not let anyone operate without instruction.
- If you do not understand any part of this manual or need assistance, contact your dealer.
- Retain these instructions for future reference.



ST-0025-3

Install and Operate Equipment Properly

- Before attempting to remove and re-install the fan blade, contact GSI for the recommended procedure.



ST-0033-2

Install and Operate Gas-Fired Equipment Properly

- Gas-fired equipment should be installed by a qualified pipe fitter and must conform with local codes.
- For Canada: The equipment shall be installed in accordance with the *Natural Gas and Propane Installation Code, CSA B149.1*, or the *Propane Storage and Handling Code, CSA B149.2*, or applicable provincial regulations, which should be carefully followed in all cases. Authorities having jurisdiction should be consulted before installations are made.
- For the United States: The equipment shall be installed in accordance with the *National Fuel Gas Code ANSI Z223.1/NFPA 54*.



ST-0016-2

For Your Safety

- If you smell gas:
 - Do not try to light any appliance.
 - Extinguish any open flames.
 - Do not touch any electrical switch.
 - Immediately call your gas supplier. Follow the gas supplier's instructions.
 - If you cannot reach your gas supplier, call the fire department.
- The use and storage of gasoline and other flammable vapors and liquids in open containers in the vicinity of this appliance is hazardous.
- Improper installation, adjustment, alteration, service or maintenance can cause property damage, injury or death. Read the installation, operating and maintenance instructions thoroughly before installing or servicing this equipment. Installation and service must be performed by a qualified installer, service agency or the gas supplier.



ST-0024-1

1. Safety

Install and Operate Electrical Equipment Properly

- Electrical controls must be installed by a qualified electrician and must meet the standards set by applicable local codes (National Electric Code for the US, Canadian Electric Code, or EN60204:2006 along with applicable European Directives for Europe).
- Be sure equipment and bins are properly grounded.
- Lock-out power source before making adjustments, cleaning, or maintaining equipment.

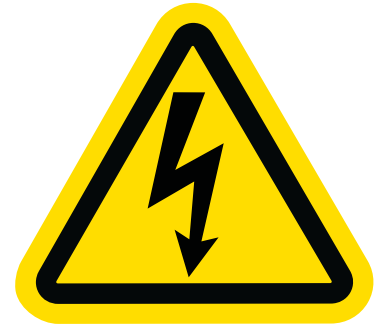

ST-0027-3

Maintain Equipment and Work Area

- Understand service procedures before doing work.
- Keep area clean and dry.
- Do not service equipment while it is operating. Disconnect and lock-out power and fuel supply before entering equipment or before performing maintenance.
- Keep your equipment in proper working condition. Replace worn or broken parts immediately.
- Depressurize the fuel train before disassembling for service.
- Allow the fan to operate for 20 minutes with the burner off to purge products of combustion and to cool the components before entering.
- Check regularly for any developing gas plumbing leaks. Do not operate the dryer if any gas leak is detected. Shut down and repair before further operation.



ST-0030-2

Fall Hazard

- Keep access door closed while on a platform to avoid falls.
- Always use proper personal protective equipment and proper clothing when using equipment. Failure to follow safety precautions can result in severe injury or death.



ST-0042-2

Exercise Caution When Drying Flammable Grains

- Be aware that some grains are highly flammable including, but not limited to, rapeseed, canola, linseed, sunflower and milo.
- All grain and seed must be whole (minimal cracking or crushing), clean, and dust free before drying.
- Avoid dust and chaff from being drawn into the fan and heater.
- To reduce risk of fire, keep the fan, heater, drying plenum, and ducts clean at all times.
- In the event of a fire (or suspected fire):
 1. Shut down the entire dryer.
 2. Turn off fuel at the tank or supply valve.
 3. Shut off and lock electrical power.
 4. Evacuate the area.
 5. Call the fire department.



ST-0032-1

Stay Clear of Hoisted Equipment

- Always use proper lifting or hoisting equipment when assembling or disassembling equipment.
- Do not walk or stand under hoisted equipment.
- Always use sturdy and stable supports when needed for installation. Not following these safety precautions creates the risk of falling equipment, which can crush personnel and cause serious injury or death.



ST-0047-1

Maintain Equipment and Work Area

- Equipment is intended for the use of grain drying only. Any other use is a misuse of this equipment.
- The operating instructions in this manual pertain to the common cereal grains as indicated. When drying any other grain, contact GSI for additional recommendations.
- Be certain that capacities of auxiliary conveyors are matched to dryer metering capacities.
- On LP fired units, set pressure regulator to avoid excessive gas pressure applied to the burner during ignition and operation. Do not exceed maximum recommended drying temperatures.
- Equipment has sharp edges that can cause serious injury. To avoid injury, handle sharp edges with caution and use proper protective clothing and equipment at all times.
- All guards must be in place before and during operation. Images of guards removed in this manual are for illustration purposes only.
- Use caution when working around high-speed fans, gas burners, augers and auxiliary conveyors which can start automatically.
- Keep hands, feet, and clothing away from moving parts.
- Do not bypass any safety device or interlock.
- Do not enter the dryer or bin while it is operating.
- Do not operate in an area where combustible material will be drawn into the dryer.

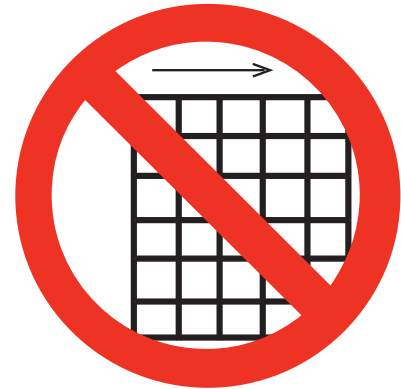

ST-0034-2

Confined Space Hazards and Entry Procedures

- Note that the interior of this equipment is considered a confined space. Maintenance of this equipment can require access to the confined space.
- Access doors must be shut and locked except when access is required.
- Doors giving access to dangerous equipment must be safety interlocked.
- The following entry procedures must be followed:
 - Be aware of all possible hazards present inside the confined space and wear personal protective equipment (PPE) as needed.
 - Complete a permit to work and follow all permit required confined space entry procedures defined by the site manager.
 - Make sure that the area has been purged of any hazardous products or gases. Check the atmosphere for harmful gases or vapors with a suitable gas analyzer and make sure levels are safe before entering.
 - Do not smoke or use naked flames.
 - Lock out and tag out power supplies and fuel supplies to all equipment.
 - Do not work alone. Work in teams of at least three so that help is immediately available in the event of an emergency.
 - Confirm that all personnel have safely exited the equipment and tools have been recovered once work is complete.



ST-0055-1

Fall Hazard

- Ladders, stairways and platforms are for use by competent and trained personnel only. Do not allow children or other unauthorized persons to have access to the equipment.
- Access to the equipment must be restricted by the use of security fencing and lockable gates.
- Lower sections of ladders must be fitted with a lockable safety gate to prevent unauthorized access.
- Make sure that hot surfaces have had adequate time to cool before working on or in the equipment.
- Lock out and tag out power supplies and fuel supplies to all equipment.
- Do not attach lifting equipment to ladders or platforms.
- Do not go outside of the safety rails provided on elevated platforms.
- Do not work at heights during high winds, rain, snow, or ice storms.



ST-0056-1

Safety Sign-Off Sheet

Below is a sign-off sheet that can be used to verify that all personnel have read and understood the safety instructions. This sign-off sheet is provided for your convenience and personal record keeping.

<i>Date</i>	<i>Employee Name</i>	<i>Supervisor Name</i>

ST-0007

Safety Precautions

1. Gas/liquid fuel supply must be in accordance with European Standards, EU Directives and Local Codes/Regulations.
2. **DISCONNECT** and **LOCK OUT** all power and fuel before adjusting, servicing, accessing or entering the dryer or associated equipment. The **ONLY** safe place to do this is at the main power panel. **TURN OFF** the incoming power at the main disconnect, **LOCK** the handle and **TAG** it to prevent inadvertent re-start. Be sure to lock out any other equipment attached to the dryer such as elevators and conveyors.

NEVER rely on the ON/OFF controls at the PLC interface. These are not safety shut offs.

In addition, ensure the gas supply has been locked out at the main gas valve feeding the dryer.

3. Observe recommended drying temperatures.
4. Keep fan inlets clear of any foreign objects.
5. Keep drive belts correctly tensioned.
6. Dryer operators must be trained and competent.

Precautions to Reduce Risk of Fire

Whilst the dryer has been designed to minimize the risk of ignition of combustible dust and dirt, this can only be ensured by regular inspection and cleaning. **At least every five (5) days.**

1. Refer the required precautions before entering the dryer. The dryer must be locked out and tagged at the main power and fuel supply before entering.
2. Open the dryer access hatches and check for any significant build-up of dust or particles of grain.
3. Using an industrial vacuum cleaner, clean the plenum. **Do not use compressed air.**
4. Check inside other dryer accesses and clean as required.
5. Check all personnel are out of the dryer, close and lock all accesses before re-starting drying.
6. This procedure may be carried out more regularly in conditions of extreme dust and dirt.

2. Decals

Safety decals must be read and understood by all people in and around the dryer area. If any safety decals are not displayed on the dryer or if they are damaged, contact The GSI Group, Inc. for replacement:

International Decals

International, translated versions of the decals fitted to the equipment are available as part of the Language Pack that was supplied with the product. If you need further copies or a different language, please contact GSI or your dealer.

The international decals have been designed to be placed directly over the USA standard versions. Normally these will be factory fitted, but if you need to change them, please refer to the decal cross reference sheet, provided with the Language Pack and the decal locations given in the user's manual.

Decals

1004 E. Illinois St.
Assumption, IL. 62510
Phone: 1-217-226-4421





- Automatic Machinery
- Automatické stroje a zařízení
- Automatikus Machinery
- автоматични машини
- automatische machines
- Автоматические машины
- автоматичні машини
- Automātiskā Mašīnas
- Automatinis Machinery
- machines automatiques
- Maquinaria automática
- macchine automatiche
- automatiska maskiner
- Otomatik Makina
- Máquinas automáticas
- Aparate
- Automaattinen Machinery



GSI Group 217-226-4421

DC-2161

DC-2161

DC-2161 is located on the inside and outside of the roof access hatches.

Size: 8.860" x 5.910"

Quantity: 2



GSI Group 217-226-4421

DC-2163

DC-2163

DC-2163 is located on the outside and inside of the main power panel doors.

Size: 3.940" x 1.970"

Quantity: 3

2. Decals



- Automatic Machinery
- Automatické stroje a zařízení
- Automatikus Machinery
- автоматични машини
- automatische machines
- Автоматические машины
- автоматичні машини
- Automātiskā Mašīnas
- Automatinis Machinery
- machines automatiques
- Maquinaria automática
- macchine automatiche
- automatiska maskiner
- Otomatik Makina
- Máquinas automáticas
- Aparate
- Automaattinen Machinery

GSI Group 217-226-4421



DC-2164

DC-2164

Background: White

Size: 3.940" x 1.970"

Colors: Black, ANSI Yellow and ANSI Blue



- Automatic Machinery
- Automatické stroje a zařízení
- Automatikus Machinery
- автоматични машини
- automatische machines
- Автоматические машины
- автоматичні машини
- Automātiskā Mašīnas
- Automatinis Machinery
- machines automatiques
- Maquinaria automática
- macchine automatiche
- automatiska maskiner
- Otomatik Makina
- Máquinas automáticas
- Aparate
- Automaattinen Machinery

GSI Group 217-226-4421

DC-2165



DC-2165

DC-2165 is located on the heat section inner and outer access hatches.

Size: 3.940" x 5.910"

Quantity: 2



GSI Group 217-226-4421

DC-2212

DC-2212

DC-2212 is located on the outside of the hopper service access hatch.

Size: 5.000" x 3.000"

Quantity: 2



- Automatic Machinery
- Automatické stroje a zařízení
- Automatikus Machinery
- автоматични машини
- automatische machines
- Автоматические машины
- автоматичні машини
- Automātiskā Mašīnas
- Automatinis Machinery
- machines automatiques
- Maquinaria automática
- macchine automatiche
- automatiska maskiner
- Otomatik Makina
- Máquinas automáticas
- Aparate
- Automaattinen Machinery

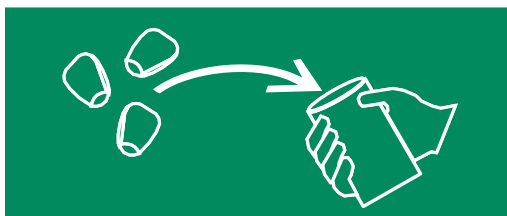
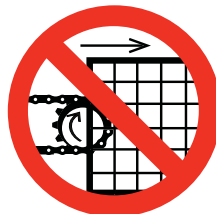

GSI Group 217-226-4421

DC-2214

DC-2214

DC-2214 is located on the grain sampling access hatch.

Size: 3.000" x 4.000"

Quantity: 1



GSI Group 217-226-4421

DC-2215

DC-2215

DC-2215 is located on the upper and middle level access hatches.

Size: 6.000" x 8.000"

Quantity varies with size of dryer.

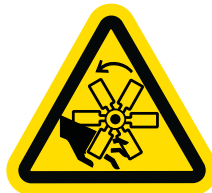

GSI Group 217-226-4421

DC-2216

DC-2216

DC-2216 is located on the cool section (intake plenum) access hatch.

Size: 6.000" x 8.000"

Quantity: 1

2. Decals



GSI Group 217-226-4421

DC-2217

DC-2217

DC-2217 is located adjacent to the electrical lock out handle on the main power panel.

Size: 2.000" x 3.000"

Quantity: 1

- Automatic Machinery
- Automatické stroje a zařízení
- Automatikus Machinery
- автоматични машини
- automatische machines
- Автоматические машины
- автоматичні машини
- Automātiskā Mašīnas
- Automatinis Machinery
- machines automatiques
- Maquinaria automática
- macchine automatiche
- automatiska maskiner
- Otomatik Makina
- Máquinas automáticas
- Aparate
- Automaattinen Machinery



GSI Group 217-226-4421

DC-2230

DC-2230

Background: White

Colors: Black, ANSI Yellow and ANSI Blue

Size: 6.000" x 3.000"

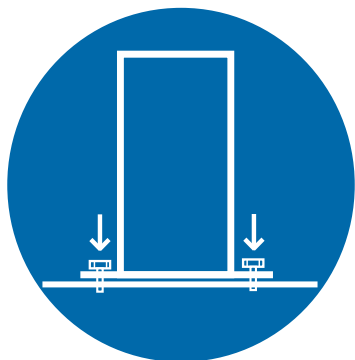

GSI Group 217-226-4421

DC-2231

DC-2231

DC-2231 is located on the outside of the main power panel doors.

Size: 6.000" x 3.000"

Quantity: 2



GSI Group 217-226-4421

DC-2232

DC-2232

DC-2232 is located on roof panels adjacent to roof steps.
 Size: 4.875" x 3.000"
 Quantity: 4

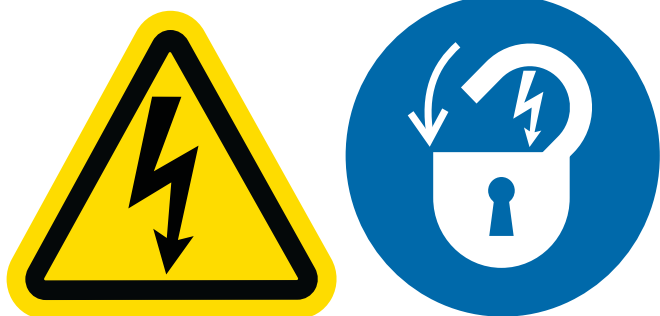

GSI Group 217-226-4421

DC-2235

DC-2235

DC-2235 is located on the inside and outside main power panel door.
 Size: 4.875" x 3.000"
 Quantity: 2



- All maintenance procedures must be performed by qualified personnel who are familiar with the operation of this equipment.
- Failure to observe this warning can result in serious or even fatal injury and/or equipment damage.

- If an overload or a fault current interruption occurs, circuits must be checked to determine the cause of the interruption.
- If a fault condition exists, the current-carrying components should be examined and replaced if damaged, and the integral current sensors must be replaced.
- To maintain overcurrent short circuit and ground fault protection, the manufacturer's instructions for selecting overload relays and setting the instantaneous trip circuit breaker must be followed.
- Be sure that charge light and all LED's are out before touching any components.
- All test equipment should be connected and disconnected with power off.
- Ground test equipment, such as oscilloscopes, may damage the inverter.
- Isolate all instruments from ground before using. The DC bus remains charged for several minutes after power is removed.

GSI Group 217-226-4421

DC-2305

DC-2305

DC-2305 is located on the inside main power panel door.
 Size: 6.000" x 5.250"
 Quantity: 1

For precise location of all safety decals, please refer to manual provided with the language pack for the dryer.

3. Installation Requirements

Electrical

Standard voltages are:

1. 240, 480 or 575V, 60 Hz
2. 380V, 400V or 415V, 50 Hz

The power panel includes:

1. Main power disconnect.
2. Motor starters and overloads. (Standard direct on line, star/delta and soft start are options.)
3. Control circuit breakers for the individual blower motors.
4. Auxiliary 7.5 kW motor starters for dry and wet grain handling equipment.
5. A correctly designed power supply is required, including safety earth connection.

Please note that the figures given [on Page 58](#) are minimum figures and do not take into account starting currents. Please allow for these when designing the required power supply for your dryer.

Tower Dryer Minimum Power Requirements

Supply Voltage	3 Phase Minimum Power Requirements (A)						
	230	380	400	415	440	460	575
Model #							
Z-1210	218	132	125	121	114	109	87
Z-1512	250	151	144	138	131	125	100
Z-1816	250	151	144	138	131	125	100
Z-2018	308	186	177	171	161	154	123
Z-2420	308	186	177	171	161	154	123
Z-2521	361	219	208	200	189	181	144
Z-3026	433	262	249	240	226	217	173
Z-3531	499	302	287	277	261	250	200
Z-4036	595	360	342	330	311	298	238
Z-4742	595	360	342	330	311	298	238
Z-5046	771	466	443	427	403	385	308
Z-6055	771	466	443	427	403	385	308
Z-7060	945	571	543	523	494	472	378
Z-10090	1235	747	710	684	646	618	494
T-1050	204	123	117	113	106	102	81
T-1260	226	136	130	125	118	113	90
T-1575	258	156	148	143	135	129	103

Tower Dryer Minimum Power Requirements (Continued)

Supply Voltage	3 Phase Minimum Power Requirements (A)						
	230	380	400	415	440	460	575
Model #							
T-1875	258	156	148	143	135	129	103
T-20100	316	191	181	175	165	158	126
T-24100	316	191	181	175	165	158	126
F-1050	204	123	117	113	106	102	81
F-1260	226	136	130	125	118	113	90
F-1575	258	156	148	143	135	129	103
F-1875	258	156	148	143	135	129	103
F-20100	316	191	181	175	165	158	126
F-24100	316	191	181	175	165	158	126
G-1200	228	138	131	126	119	114	91
G-1500	260	157	150	144	136	130	104
G-1800	260	157	150	144	136	130	104
G-2000	318	192	183	176	166	159	127
G-2400	318	192	183	176	166	159	127
G-2500	370	224	213	205	193	185	148
G-3000	442	267	254	245	231	221	177
G-3500	508	307	292	281	266	254	203
G-4000	604	365	347	335	316	302	242
G-4718	604	365	347	335	316	302	242
G-5000	778	471	447	431	407	389	311
G-6000	778	471	447	431	407	389	311
G-7000	952	576	547	527	498	476	381
G-10000	1240	750	713	687	648	620	496

Fuel

- Fuel types are LPG or natural gas vapor.
- Minimum supply pressure is,
 - 350 mBar natural gas at full burner flow rate.
 - 350 mBar LPG vapor at full burner flow rate. Higher pressures may be required to obtain maximum burner output.
- Burner flow rates are as shown [on Page 24](#). Liquid propane vaporization is either in tank or via external vaporizer.

3. Installation Requirements

Dryer Fuel Specification and Commissioning Set Points

T and F Series	T/F-1260	T/F-1575	T/F-1875	T/F-1054	T/F-20100	T/F-24100								
Zimmerman	Z-1210	Z-1512	Z-1816	Z-2018	Z-2420	Z-2521	Z-3026	Z-3531	Z-4036	Z-4742	Z-5046	Z-6055	Z-7060	Z-10090
GSI	G-1200	G-1500	G-1800	G-2000	G-2400	G-2500	G-3000	G-3500	G-4000	G-4718	G-5000	G-6000	G-7000	G-10000
Max. Burner Output (kW)	3831	4882	5180	6244	6858	7722	9195	11133	12206	13526	17628	19301	21372	31662
Average Burner Output (kW)	2203	2807	2979	3590	3943	4440	5287	6401	7018	7777	10268	11098	12289	18206
LPG Fuel	LPG Gross CV 93.8 MJ/m³													
Max. Gas Flow LPG (m ³ /h)	147	187	199	240	263	296	353	427	468	519	677	741	820	1215
Average Gas Flow LPG (m ³ /h)	85	108	114	138	151	170	203	246	269	298	394	426	472	699
Supply Pressure (mBar) ¹	350-700	350-700	350-700	350-700	350-700	350-700	350-700	350-700	350-700	350-700	350-700	350-700	350-700	350-700
Regulator Setting (mBar) ²	206	206	206	206	206	206	206	206	206	206	206	206	206	206
Regulator Spring	Cadmium	Cadmium	Cadmium	Cadmium	Cadmium	Cadmium	Cadmium	Cadmium	Cadmium	Cadmium	Cadmium	Cadmium	Cadmium	Cadmium
Burner Pressure High-Fire (mBar) ⁶	42	137	81	119	145	97	139	142	196	193	145	110	75	152
Burner Pressure Low-Fire (mBar) ⁷	1.7	5.5	3.2	4.8	5.8	3.9	5.6	5.7	7.8	7.7	5.8	4.4	3.0	6.1
Pilot Pressure (mBar) ³	40	40	40	40	40	40	40	40	40	40	40	40	40	40
Natural Gas Fuel	NG Gross CV 39 MJ/m³													
Max. Gas Flow NG (m ³ /h)	357	455	483	582	640	720	858	1038	1138	1262	1644	1800	1993	NA
Average Gas Flow NG (m ³ /h)	205	262	278	335	368	414	493	597	655	725	958	1035	1146	NA
Supply Pressure (mBar) ¹	350-700	350-700	350-700	350-700	350-700	350-700	350-700	350-700	350-700	350-700	350-700	350-700	350-700	NA
Regulator Setting (mBar) ²	206	206	206	206	206	206	206	206	206	206	206	206	206	NA
Regulator Spring	Cadmium	Cadmium	Cadmium	Cadmium	Cadmium	Cadmium	Cadmium	Cadmium	Cadmium	Cadmium	Cadmium	Cadmium	Cadmium	NA
Burner Pressure High-Fire (mBar) ⁶	72	119	70	101	124	86	122	121	137	167	127	96	63	NA
Burner Pressure Low-Fire (mBar) ⁷	2.9	4.8	2.8	4.0	5.0	3.4	4.9	4.8	5.5	6.7	5.1	3.8	2.5	NA
Pilot Pressure (mBar) ³	40	40	40	40	40	40	40	40	40	40	40	40	40	NA
Pressure Relief Set Point (mBar) ⁴	250	250	250	250	250	250	250	250	250	250	250	250	250	250
Pilot Valve Max. Pressure Switch (mBar)	400	400	400	400	400	400	400	400	400	400	400	400	400	400
Main Valve Max. Pressure Switch (mBar)	400	400	400	400	400	400	400	400	400	400	400	400	400	400
Main Valve Min. Pressure Switch (mBar)	50	50	50	50	50	50	50	50	50	50	50	50	50	50
Over Pressure Valve Set Point (mBar) ⁵	450	450	450	450	450	450	450	450	450	450	450	450	450	450
Regulator Size	2	2	2	2	2	3	3	3	3	3	3	3	3	3
SSOV Size	DN65	DN65	DN65	DN80	DN80	DN80	DN100	DN100	DN125	DN125	DN125	DN125	DN125	DN125
CV Valve Size	2	2	3	3	3	3	3	4	4	4	4	4	4	6
Pipe to Burner	2	2	3	3	3	3	3	4	4	4	4	6	6	6

1. Pressure from supply read at inlet gauge. (See Figure 3B on Page 26.)
2. Pressure after regulator read at sensing line gauge. (See Figure 3C on Page 27.)
3. Pressure set with pilot flow adjuster on pilot valve (See Figure 3D on Page 28) read at pilot gauge. (See Figure 3D on Page 28).
4. Relief valve. (See Figure 3C on Page 27.)
5. OPSO valve. (See Figure 3C on Page 27.)
6. Burner pressure with modulating valve at maximum read at burner pressure gauge. (See Figure 3F on Page 30.)
7. Burner pressure with modulating valve at minimum read at burner pressure gauge. (See Figure 3F on Page 30.)

Tower Dryer Pipe Train Assembly

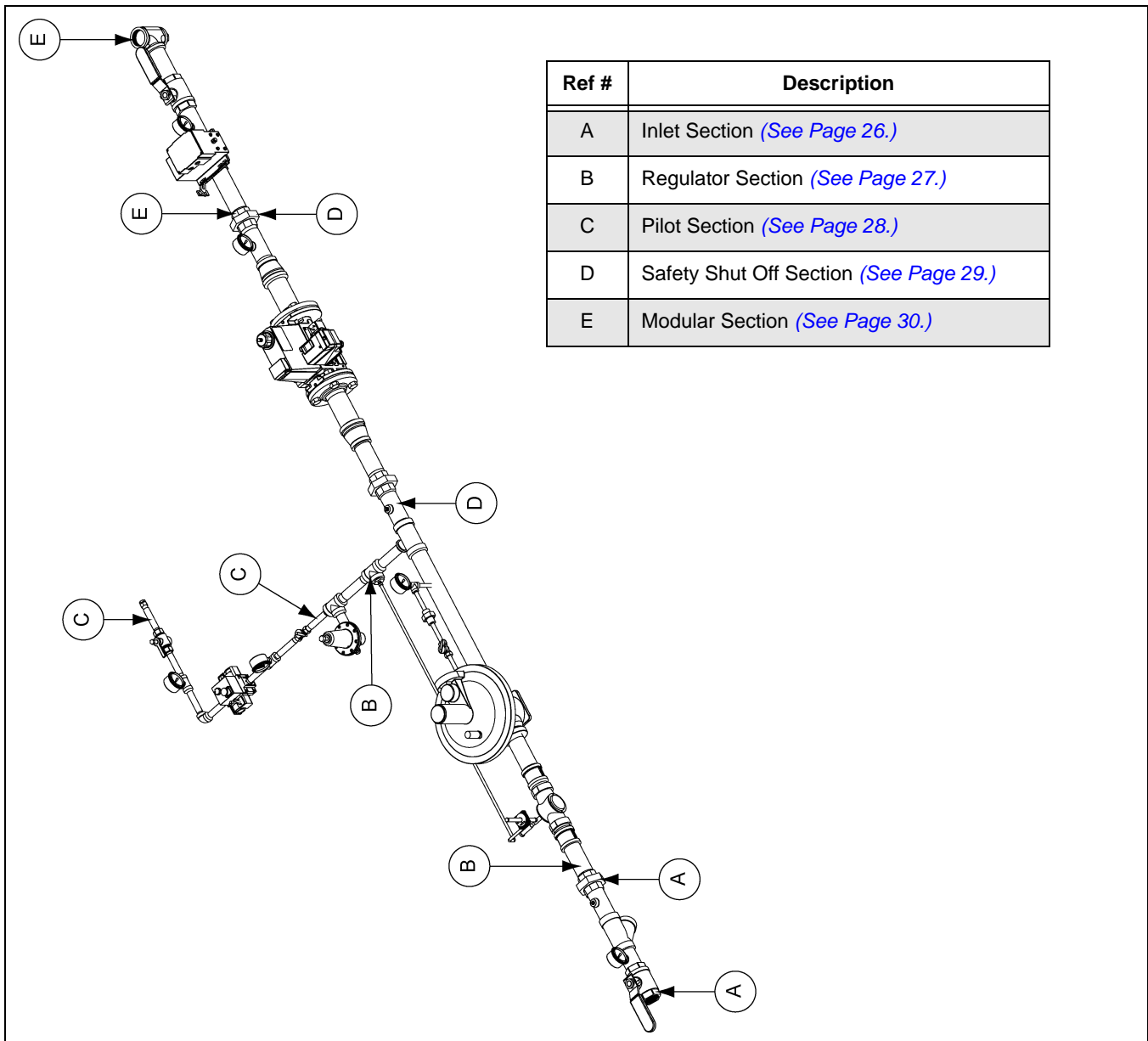

Figure 3A Tower Dryer Pipe Train (2" Shown)

3. Installation Requirements

Inlet Section

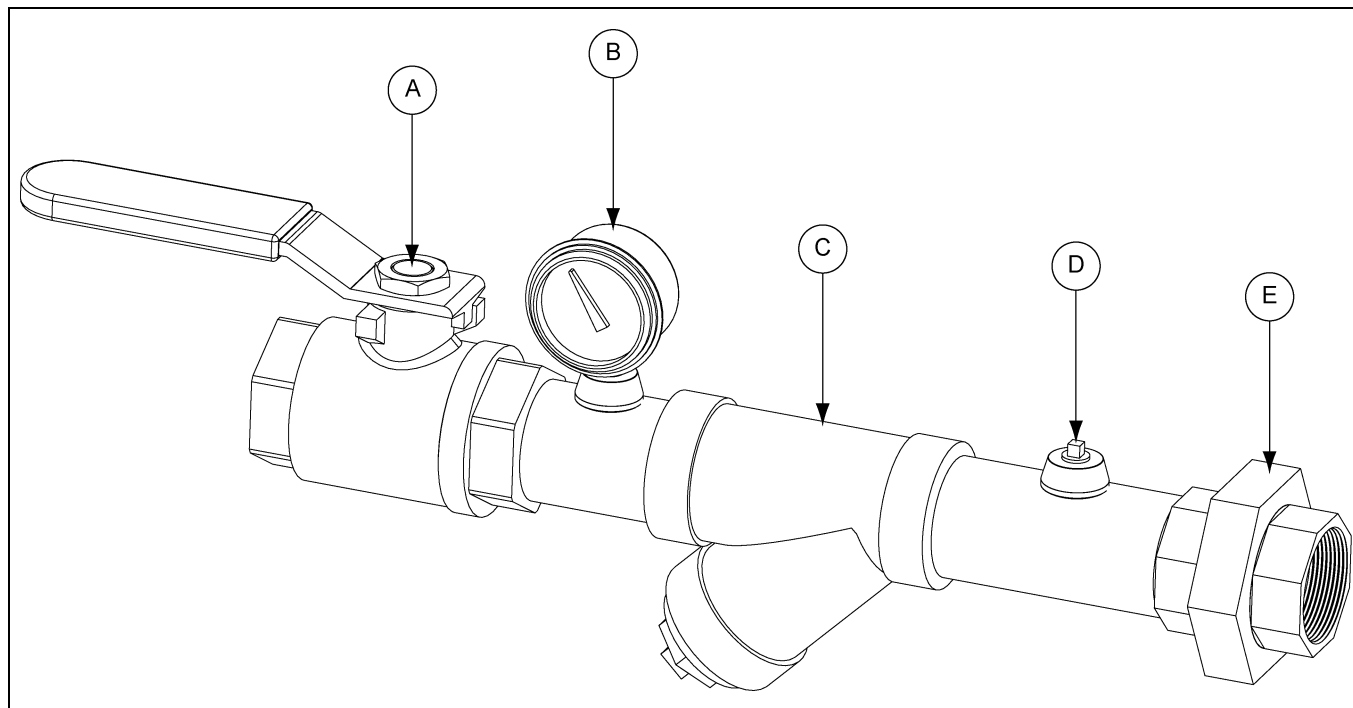

Figure 3B

Ref #	Description
A	Manual Shut Off
B	Inlet Pressure Gauge
C	Filter
D	Test Point
E	Union

Regulator Section

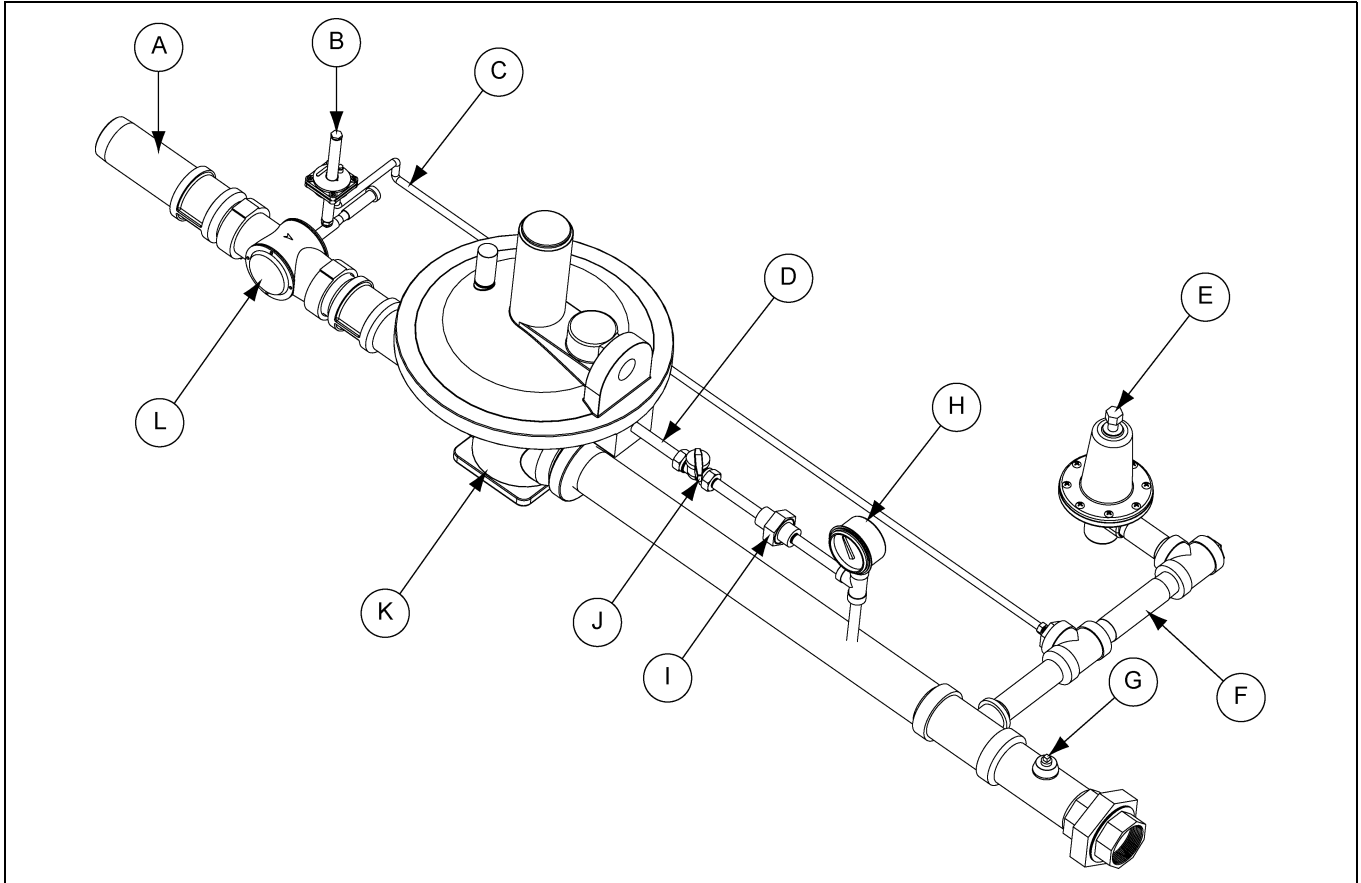

Figure 3C

Ref #	Description
A	Nipple
B	OPSO Adjuster
C	OPSO Sensing Line
D	Regulator Sensing Line
E	Pressure Relief
F	Pilot Line
G	Test Point
H	Pressure Gauge
I	Union
J	Sensing Line Trim Valve
K	Pressure Regulator
L	Over Pressure Shut Off (OPSO)

3. Installation Requirements

Pilot Section

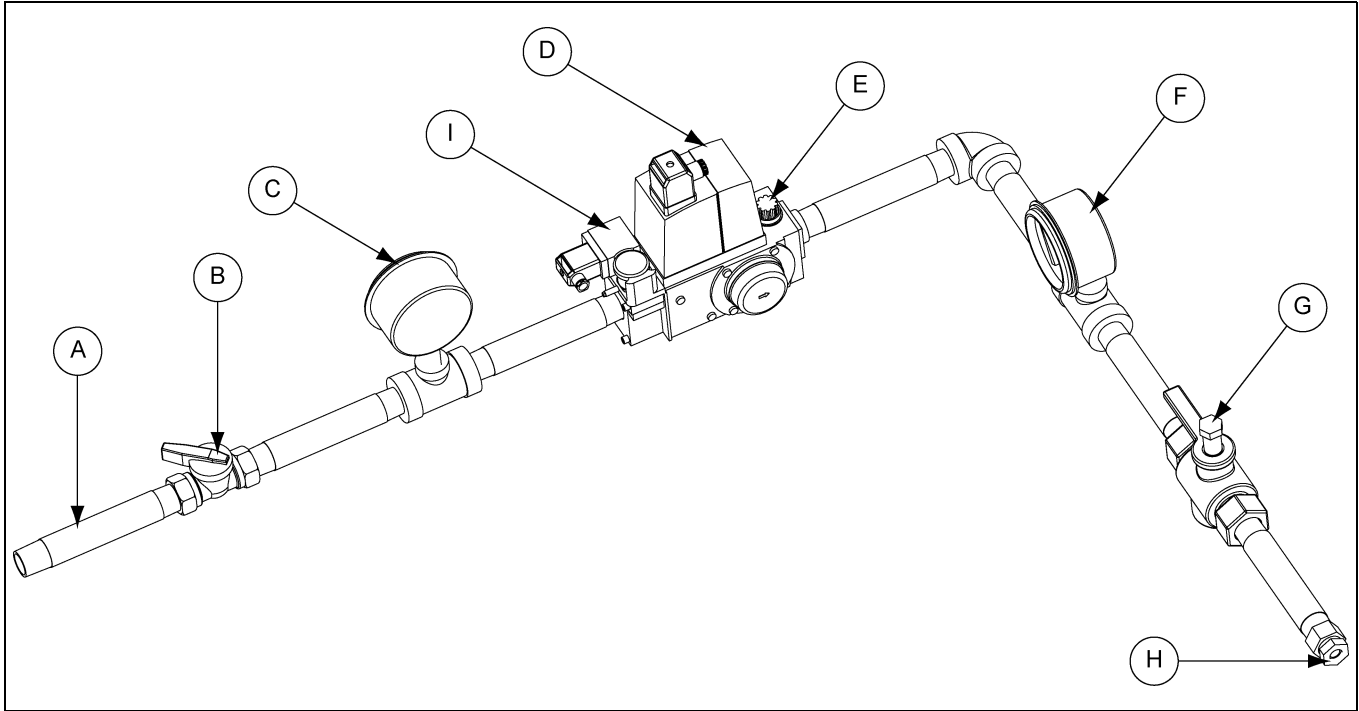

Figure 3D

Ref #	Description
A	Nipple
B	Pilot Shut Off Valve (Manual)
C	Pressure Gauge
D	Pilot Line Double Safety Shut Off Solenoid Valve
E	Pilot Flow Adjuster
F	Pilot Pressure Gauge
G	Manual Shut Off
H	Pilot Line Connection Point
I	Pilot Low Pressure Switch

Safety Shut Off Section

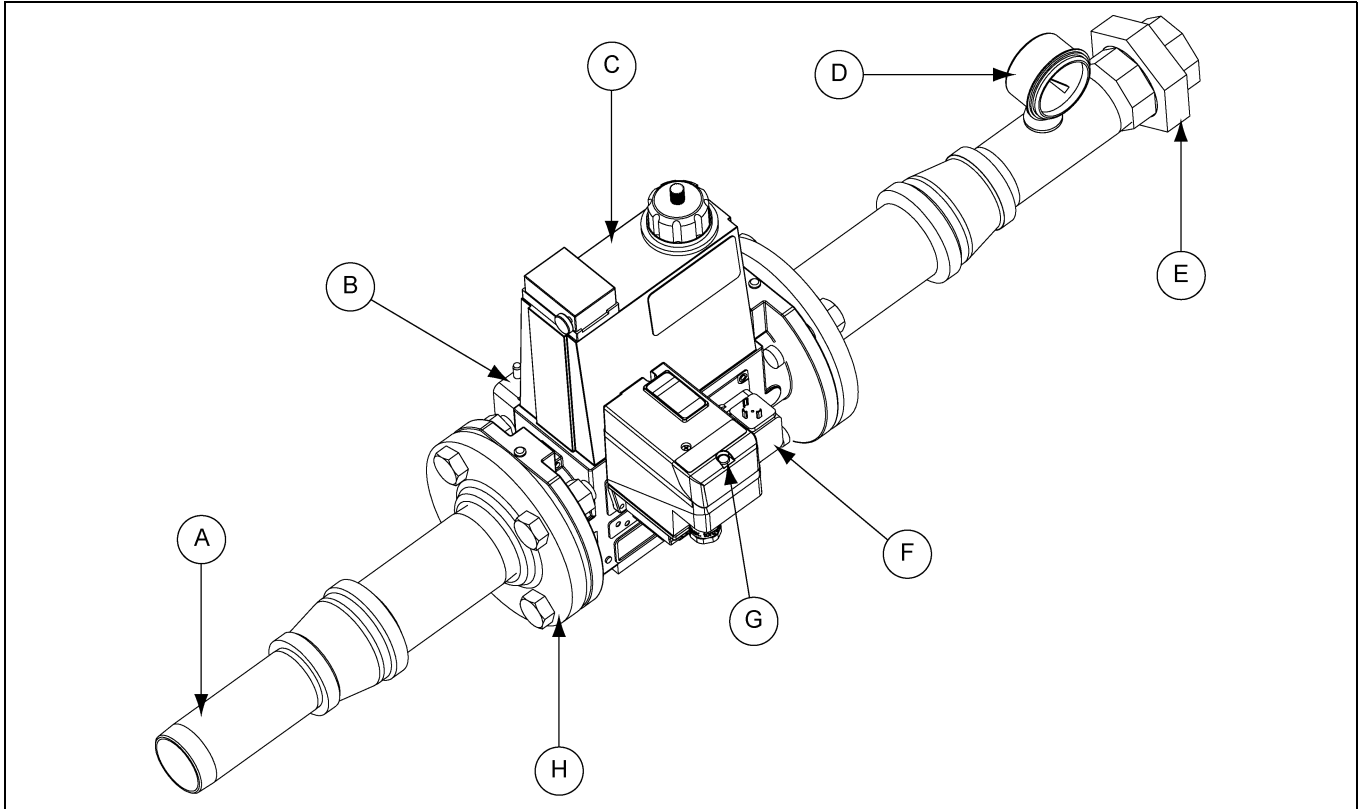

Figure 3E

Ref #	Description
A	Nipple
B	Low Pressure Switch
C	Double Safety Shut Off Solenoid Valve
D	Pressure Gauge
E	Union
F	High Pressure Switch
G	Valve Proving System
H	Din Flange

3. Installation Requirements

Modulator Section

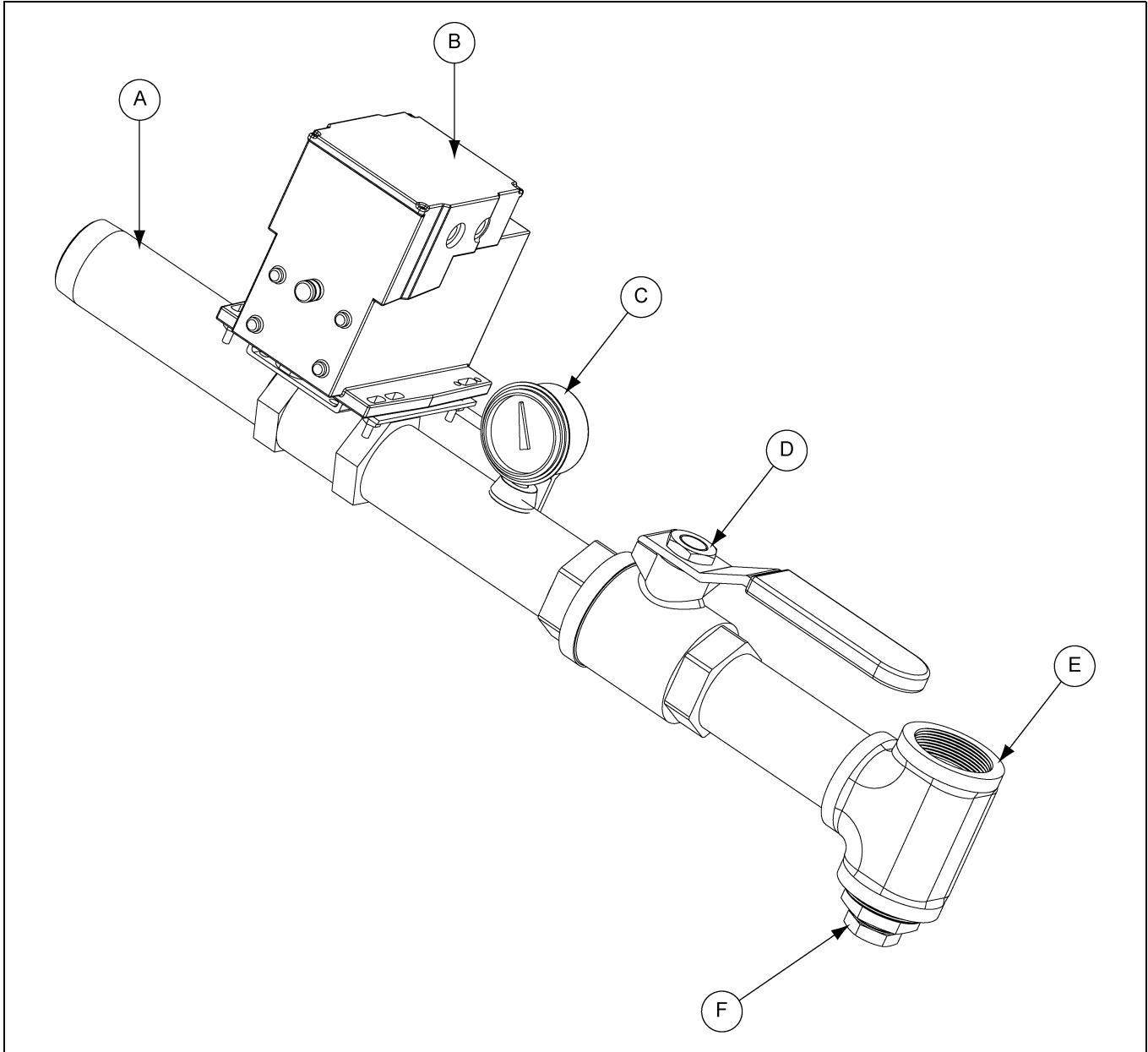

Figure 3F

Ref #	Description
A	Nipple
B	Maxon Valve Motor
C	Pressure Gauge
D	Firing Valve
E	Connection to Burner Line
F	Drain Point (Valve not shown.)

PLC Dryer Control Panel

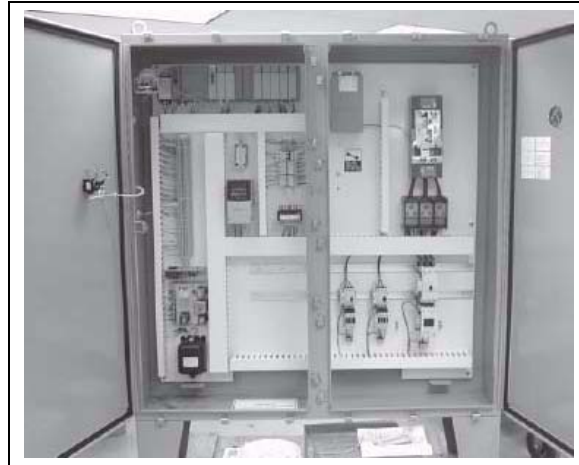

Figure 3G PLC Dryer Control Panel

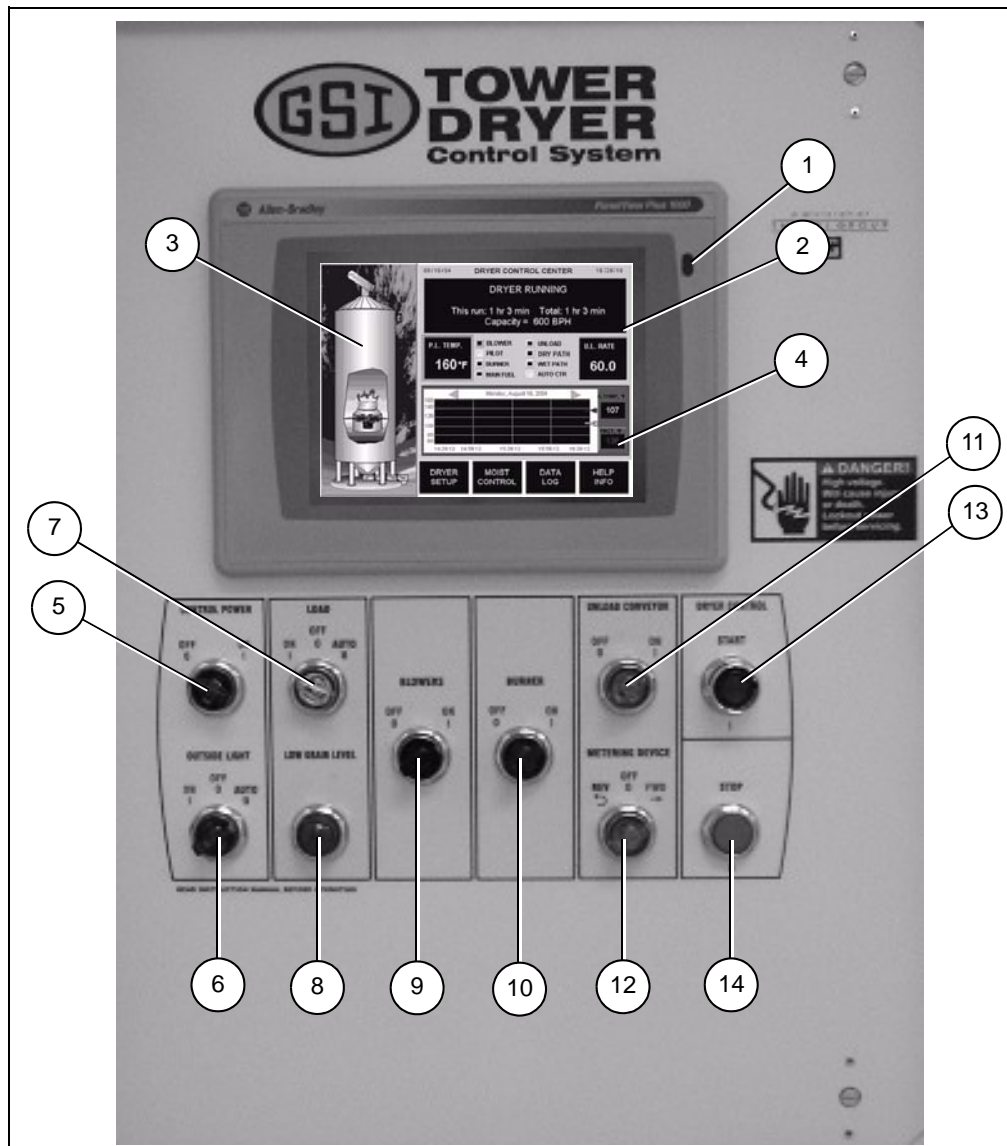

Figure 3H PLC Control Screen

3. Installation Requirements

1. **Display** provides visual feedback and touch screen control.
2. **Message Center** displays current dryer conditions and alarm messages and troubleshooting.
3. **Dryer View** provides indication of dryer functions and access to burner and grain flow status screens.
4. **Temperature/Moisture History Chart** records up to 32 hours of dryer temperature and/or moisture data.
5. **Control Power switch** allow 60 seconds for start-up.
6. **Outside Light switch** ON/OFF/AUTO.
7. **Load switch** controls dryer filling ON/OFF/AUTO.
 - 'On demand' filled dryers (conveyor or slide gate):
 - a. ON or AUTO - Fill system starts/opens or stops/closes according to grain level.
 - b. AUTO - As above plus dryer shuts down on low grain after the OUT OF GRAIN TIMER expires.
 - 'Choke' filled dryers:
 - a. AUTO - Dryer shuts down on low grain after the OUT OF GRAIN TIMER expires.
 - b. ON or OFF - OUT OF GRAIN TIMER is disabled, the LOAD switch illuminates when load system is powered.
8. **Low Grain Light**
 - a. Flashes when grain level is low before shut down.
 - b. Continuous after low grain shut down.
9. **Blowers switch** - Controls blowers.
 - a. Blowers start sequentially.
 - b. Switch flashes during blower start-up.
 - c. Continuous when air switch closes.
10. **Burner switch** - Controls burner. When ON,
 - a. Valve proving system checks valves.
 - b. Burner control checks air switch function.
 - c. Modulating valve drives to low-fire position.
 - d. 35 Seconds purge.
 - e. Pilot light ignition.
 - f. Main burner automatic ignition.
11. **Unload Conveyor switch** - Continuous light when unload is running.
12. **Metering Device switch** - Controls metering system (forward/off/reverse).
 - a. Unload conveyor must be ON.
 - b. Illuminates when system runs.
13. **Dryer Power Start button** initiates operation of the dryer.
14. **Dryer Power Stop button**
 - a. Stops all dryer functions and automatic equipment in a controlled shut down sequence.
 - b. Also effects a reset after automatic shut down.

Electrical

1. Carry out earth bonding test per EN60204 and local electrical laws and regulations.
2. Check adequate power supply. (Refer to table [on Pages 22 and 23.](#))
3. Voltage at phases must be within 5% of rated voltage.
4. Voltage drop must not exceed 5% when under full load.
5. Check overload settings for each motor circuit.
6. Complete full electrical tests in accordance with EU Directives and local laws, regulations and codes.

Gas Train

1. Pressure test
 - a. Close inlet valve. ([See Figure 3B on Page 26.](#))
 - b. Close firing valve. ([See Figure 3F on Page 30.](#))
 - c. Close pilot line valve. ([See Figure 3D on Page 28.](#))
 - d. Fit pressure test nipple into main solenoid inlet flange.
 - e. Attach hand bellows and pressure gauge.
 - f. Pressures gas train with air to 35 kPa (350 mBar).
 - g. Check from pressure loss at gauge.
 - h. Use leak detection to test for leaks.
 - i. Repeat on outlet flange.
 - j. Repeat on pilot line.
2. Set inlet pressure per table [on Page 24.](#)
3. Set relief valve per table [on Page 24.](#)
 - a. Apply air pressure via main solenoid inlet flange.
 - b. Increase/decrease spring pressure in relief valve.
 - c. Valve should open at 50 kPa maximum.
4. Set over pressure shut off (OPSO) per table [on Page 24.](#)
 - a. Apply air pressure via main solenoid inlet flange.
 - b. Increase/decrease spring pressure in OPSO.
 - c. Valve should shut open at 45 kPa maximum.
5. Set operational pressure per table [on Page 24.](#)
 - a. Open main gas valve.
 - b. Adjust pressure at regulator.

4. Dryer Commissioning

6. Set pilot flow rate.
 - a. Close pilot line manual shut off valve. (See Figure 3D on Page 28.)
 - b. Close 'firing valve' on main gas line. (See Figure 3F on Page 30.)
 - c. Start blowers.
 - d. Start burners.
 - e. When pilot solenoid valve opens, adjust flow rate to give required pilot pressure per table on Page 24.
 - f. Adjustment is on pilot solenoid valve. (See Figure 4A.)
 - g. Open pilot line manual shut off valve. (See Figure 3D on Page 28.)
 - h. Re-set burner control. (It will have gone to lock out after previous attempt to light.) Reset can be done by cycling the burner switch on the PLC panel.
 - i. Start burner.
 - j. Pilot should now light and stay alight. After 10 seconds, main valve should open and after further 4 seconds burner control revert to lock out and pilot extinguish (main flame is shut off). If pilot does not stay alight, then the pressure and/or flame rod will need to be adjusted to ensure the burner control is getting a strong flame current. See Step 7 below.

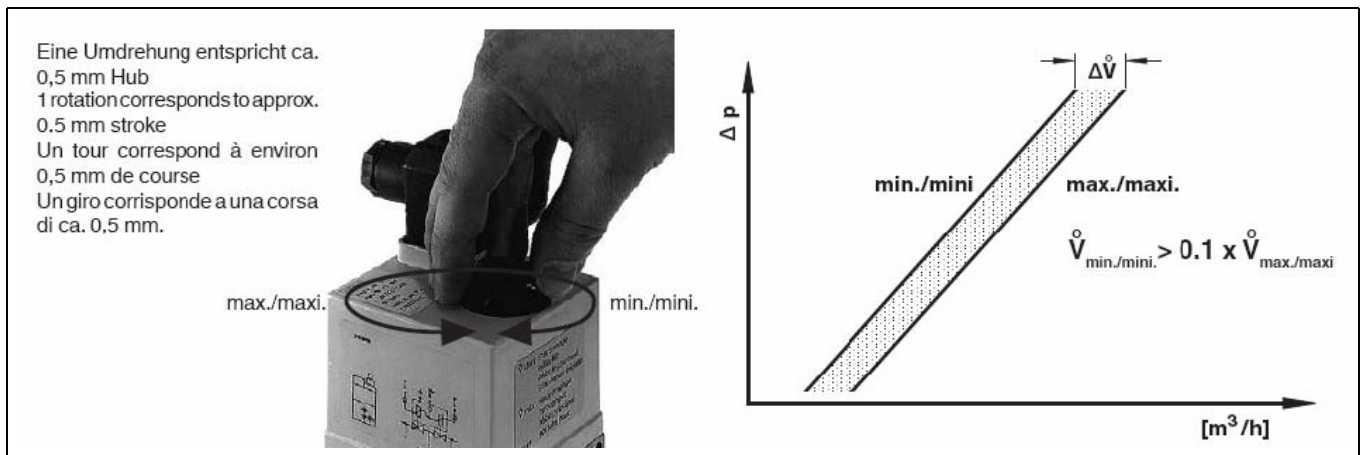
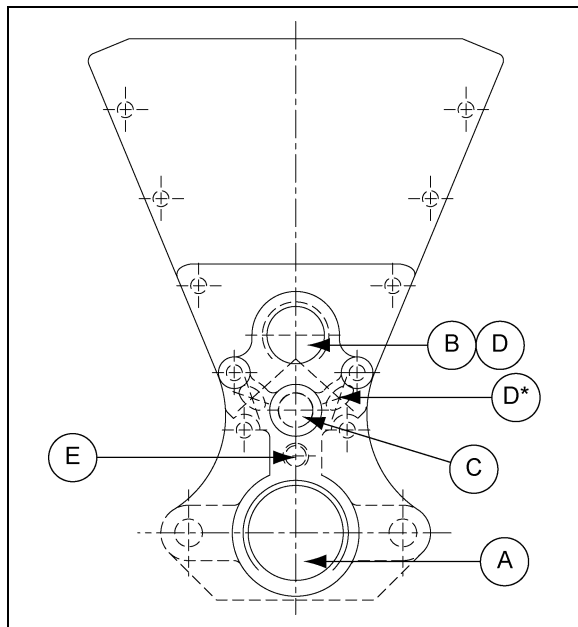

Figure 4A Pilot Valve Flow Adjustment

7. Checking pilot flame current.
 - a. The minimum flame signal, measured at the burner control, should be 1.25 VDC.
 - b. Flame signal can be checked at the Honeywell burner control, located in the main power panel, as shown in Figure 4C on Page 35.
 - c. Flame rod may be re-positioned or gently bent to get better contact with the flame. Ensure rod is well clear of burner to prevent grounding when hot. Be careful not to damage ceramic insulator surrounding flame rod. (See Figure 4B on Page 35.)
 - d. Check burner is properly grounded.
 - e. Check neutral supply to burner control is 0 VAC.



Ref #	Description
A	Main Gas
B	UV Sensor Connection (Optional)
C	Spark Ignitor
D	Flame Rod Locations
D*	Flame Rod Alternate Locations
E	Pilot Gas

Figure 4B Burner End Plate, Spark, Pilot and Flame Rod Locations

NOTE: Minimum acceptable flame signal is 1.25 VDC.

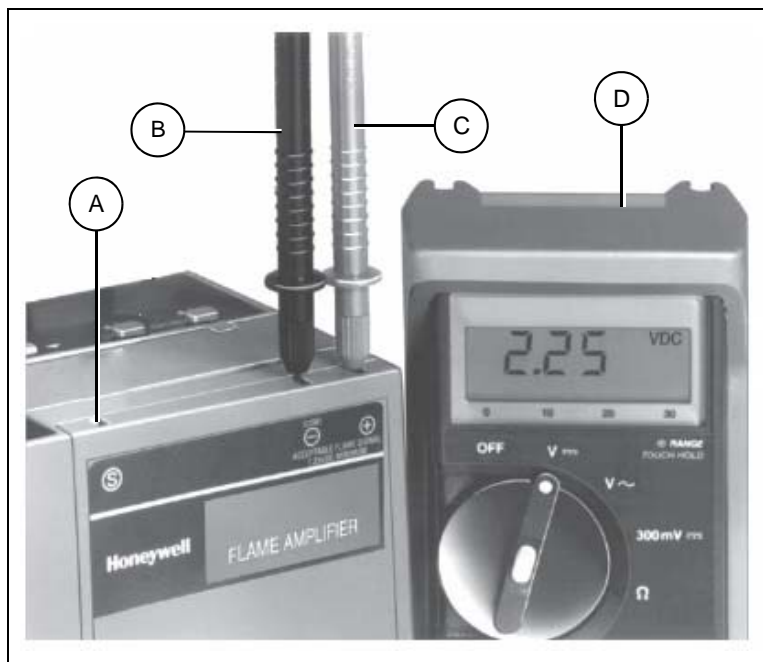

Figure 4C Honeywell Test Flame

Ref #	Description
A	Flame Simulator Test Jack
B	Negative (-) Meter Lead
C	Positive (+) Meter Lead
D	One Mega Ohm/Volt Meter

4. Dryer Commissioning

8. Set burner high-fire pressure.
 - a. Re-open main gas 'firing valve'. *(See Figure 3F on Page 30.)*
 - b. Note required high-fire pressure from table *on Page 24.*
 - c. Set plenum temperature to approximately 200°F above ambient.
 - d. Light burners.
 - e. Check modulating valve has driven fully open.
 - f. Read pressure at burner gauge. *(See Figure 3F on Page 30.)*
 - g. Adjust pressure a regulator to give required pressure.
 - h. Lock regulator.
9. Set burner low-fire pressure.
 - a. Set plenum temperature to approximately 10°F above ambient.
 - b. Light burners.
 - c. On low-fire, adjust modulating valve minimum setting to give pressure as per table *on Page 24.*
 - d. Read pressure at burner gauge. *(See Figure 3F on Page 30.)*
10. Run burners and check burner modulates correctly.
11. Check gas pressure remains stable.
12. Fill out gas train commissioning check sheet. *(See Page 4.)*

Start-Up

NOTICE

Complete pre-season inspection and service as per maintenance section on Page 48.



Close all discharge, clean out, cooling, grain exchange and heat section doors.



Make sure that all personnel are clear of the dryer and associated machinery.

1. Open main gas valve.
2. Switch ON electrical power (main disconnect to ON).
3. Check Emergency Stop buttons are fully out.
4. Switch on CONTROL POWER. Wait whilst control boots up.
5. Press Start on touch screen.
6. Press Dryer Power Start button.
7. Start auxiliary fill equipment.
8. Turn LOAD selector switch to ON. Dryer should start filling.
9. When the horn sounds (dryer full), turn the LOAD selector switch to the AUTO position to silence the alarm and begin normal dryer operation.
10. Set plenum temperature by touching the "P.L. Temp" box on the LCD display. Enter drying temperature.

Recommended drying temperatures,

- a. Corn 180°F to 210°F
 - b. Soybeans 140°F to 160°F
 - c. Wheat 140°F to 160°F
 - d. Milo 160°F to 180°F
 - e. Barley 140°F to 160°F
 - f. Oats 140°F to 160°F
11. Turn **BLOWERS selector switch to ON.**

5. Dryer Operation

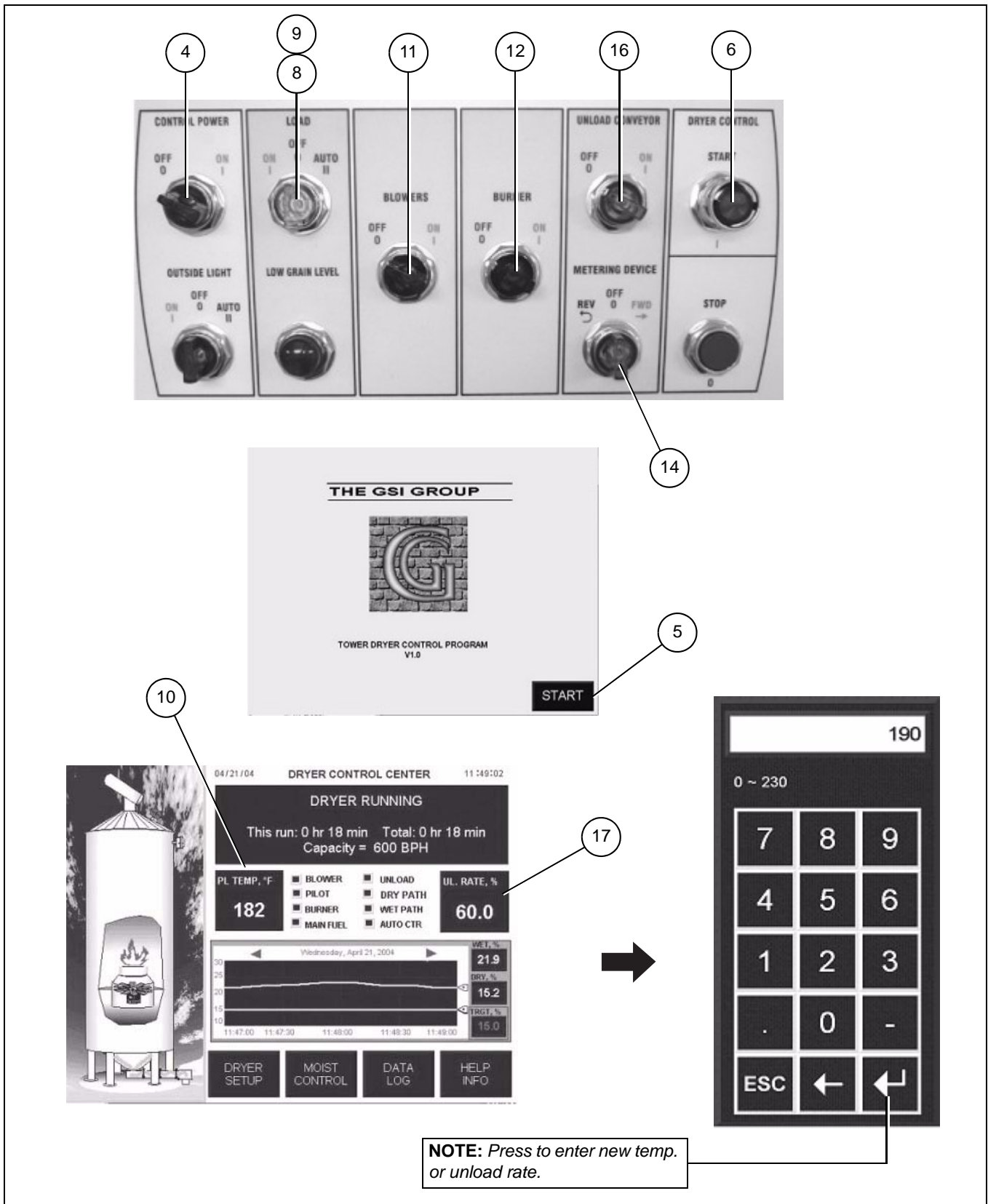

Figure 5A

12. **Start the burner.** Turn BURNER selector switch to the “ON” position.
 - a. Burner will purge for 30 seconds.
 - b. Pilot will automatically light.
 - c. If the pilot fails to light in 10 seconds the burner will lock out and must be re-set. Turn BURNER switch “OFF” then back “ON”.
13. Once pilot is established the main burner will automatically light in low flame.
14. The dryer’s plenum temperature will be automatically controlled at the selected temperature.
15. **Let plenum come up to temperature and begin drying.** Depending upon ambient conditions, the dryer may take 10 minutes or more to reach the drying temperature.
16. **Start unload system.** Check that elevators and conveyors are all running dryer. Turn the UNLOAD CONVEYOR switch to ON.

Turn the METERING DEVICE switch to “FORWARD”. Grain should now start discharging.
17. **Set Unload Rate/Moisture Control Temperature.** While operating the dryer in MANUAL mode, set the unload rate by touching the “U.L. Rate” box on the screen. On the keypad, enter the new unload rate and press return. Starting unload rates will vary with moisture, grain and temperatures, however in the absence of other data, GSI suggests starting at 30% unload rate.
18. Check discharge moisture content after 10 minutes. Take five (5) small samples from the discharge and mix before taking a moisture reading.
19. When the discharge moisture content has stabilized for 20 to 30 minutes switch to Automatic Moisture Control or Temperature Control.
 - a. Press the MOISTURE CONTROL on the screen.
 - b. On the Moisture Control Setup screen, set the upper and lower limits by touching the corresponding box and using the pop-up keypad. These values prevent the unload from moving too fast or too slow should the incoming moisture be significantly greater or less than anticipated.
 - c. Press the CONTROL MODE box to toggle between Manual and Automatic moisture control. Note that the current and target grain temperatures are displayed next to the Temperature History Chart.

NOTICE *If the discharge moisture content is consistently too high or too low, adjust the target grain temperature as follows:*

5°F Increases - 1 Moisture point decrease
5°F Decrease - 1 Moisture point increases

Allow 30 minutes between adjustments.

5. Dryer Operation

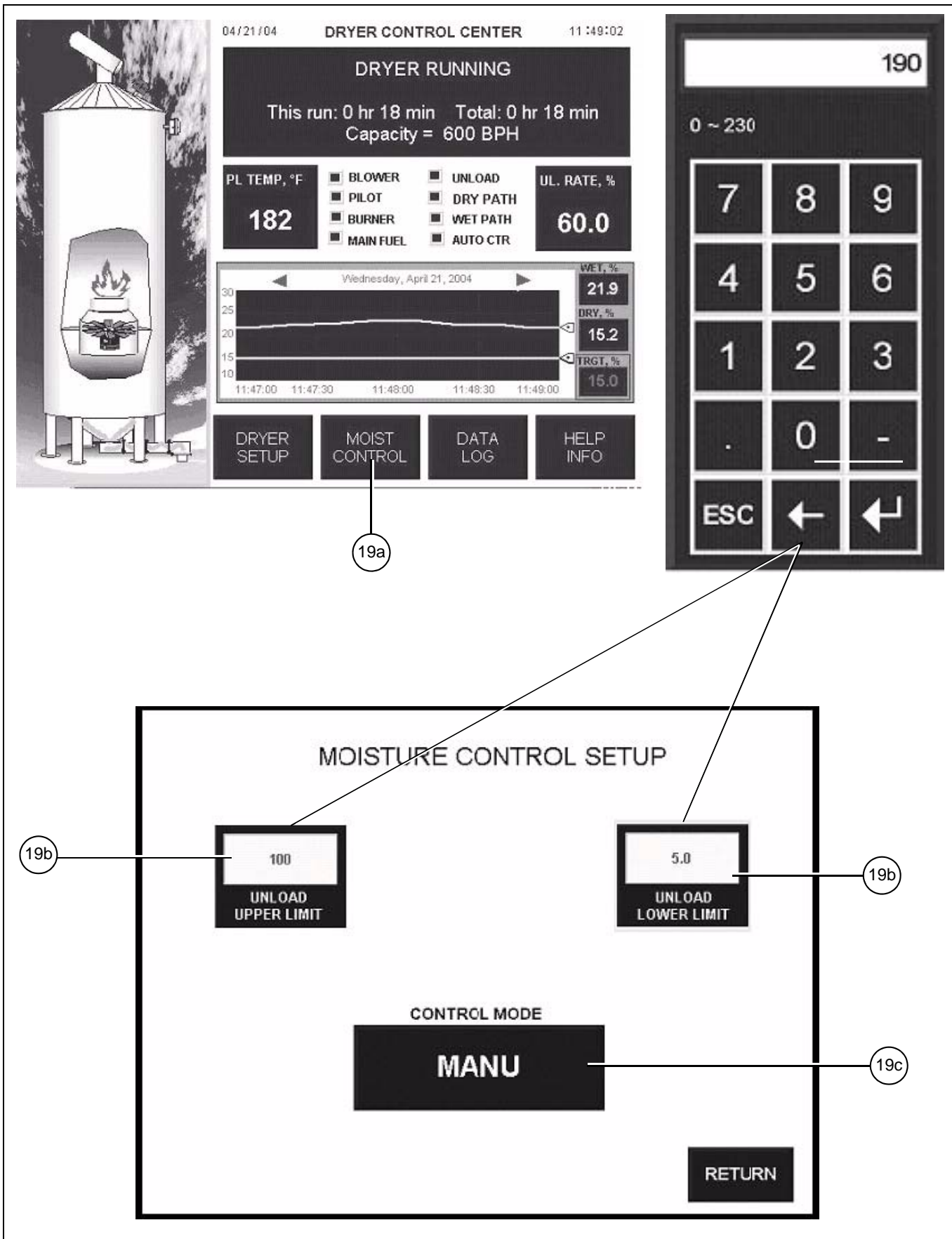

Figure 5B

Shut Down

1. Short shut downs - **Less than 4 hours**

- a. Press Dryer Power Stop button.
- b. Press Dryer Power Start to re-starting. The PLC will re-start the dryer automatically based on selector switch settings.

2. Extended shut downs - **4 hours or more**

- a. **Shut off the burner.** Turn the BURNER switch to “OFF”.
- b. **Cool down grain.** Blowers will continue to cool grain. Keep unloading during cool down to avoid overdrying grain.
- c. **Shut off unload equipment.** Turn METERING DEVICE and UNLOAD CONVEYOR switches to “OFF”.
- d. **Shut off blowers.** Turn BLOWER switch to “OFF”.
- e. **Shut off control panel.** Turn the CONTROL POWER switch to “OFF”.
- f. **Turn OFF main power.**
- g. **Close manual gas valve.**
- h. **Inspect the inside of the dryer** after operation to ensure against the possibility of hot spots or fires.

Viewing Temperature/Moisture History

Scroll left and right in the Temperature/Moisture History chart using left and right arrows.

Viewing Burner/Fuel Train Status

Press the Burner region in the Dryer View on the screen to view status of all valves as well as the modulating valve position.

Viewing Grain Flow Status

Press the Unload region in the Dryer View on the screen to view the status of all controlled/interlocked equipment in the grain flow path.

Modifying the Bushel per Hour Factor

To get a true throughput reading, the correction factor may need to be calibrated.

By default the factor is 1.0.

Calculate the percentage difference between the dryer reading as follows:

$$\% \text{ Difference} = \frac{(\text{Actual} - \text{Reading}) \times 100}{\text{Reading}}$$

5. Dryer Operation

% Difference	Calibration Factor
+25%	1.25
+20%	1.20
+15%	1.15
+10%	1.10
+5%	1.05
0%	1.00
-5%	0.95
-10%	0.90
-15%	0.85
-20%	0.80
-25%	0.75

Interpolate and extrapolate for differences not given.

To adjust the correction factor, press DRYER SETUP then the BUSHEL COUNTER button then CORRECTION FACTOR box to adjust the value.

Control Operation Principles

The controller continuously monitors incoming and outgoing moisture as well as grain temperature at the end of the drying section. The control action is mainly based on the dry sensor at the outlet of the dryer. If the moisture coming out of the dryer is not right at the target, the controller will speed up or slow down the unload device accordingly. The wet sensor and the column grain temperature sensor are intended to detect moisture spikes coming into the dryer so that the moisture controller can react ahead of time. For example, if the wet sensor detects a jump of moisture coming into the dryer, the controller will start slowing down the unload speed right away. However, the controller does not act to the full scale immediately. Instead, it slows down the dryer gradually so that the grain currently in the dryer will not be over-dried too much.

In the first pass after the dryer started, the controller does not have enough information of the grain in the dryer. It controls the dryer by using the manual speed setting as a starting point. In other words, the manual speed setting is most responsible for the first pass of drying. Therefore, set the manual unloading speed as close as it should be for the grain currently in the dryer before switching to **AUTO** control mode. The manual speed setting does not have to be adjusted after the controller is switched into **AUTO** mode.

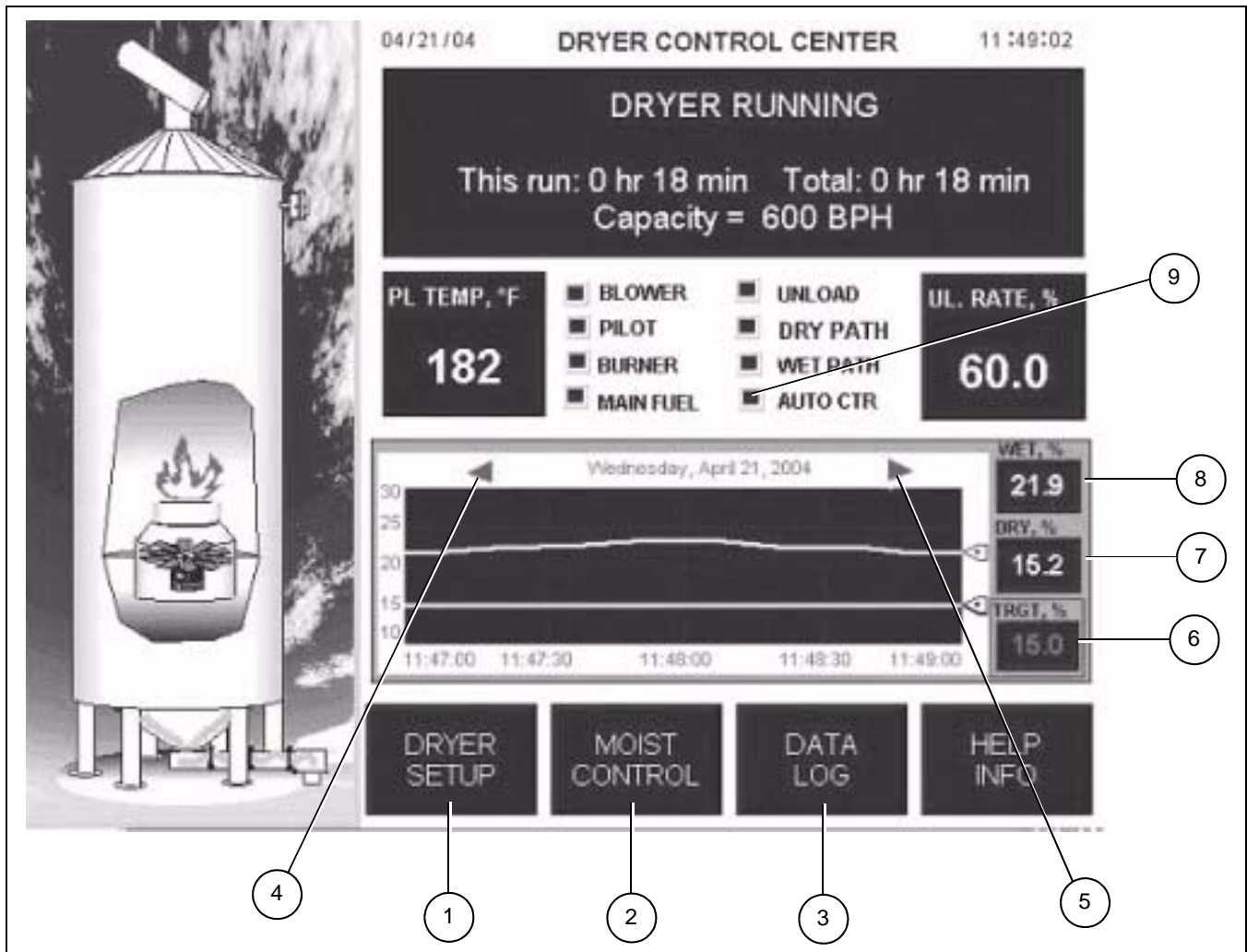

Figure 6A

6. Tri-Point Moisture Controller

1. **Moisture history chart.** View dryer history.
2. **Moisture Control button.** Set moisture control.
3. **Data Log button.** Access dryer history.
4. **Scroll Back button.**
5. **Scroll Forward button.**
6. **Target moisture.** Set required moisture.
7. **Current outgoing moisture.**
8. **Current incoming moisture.**
9. **Moisture control status.** On = Auto

Set-Up Controller

1. Press the “MOIST CONTROL” button from the main screen to access the moisture set-up.

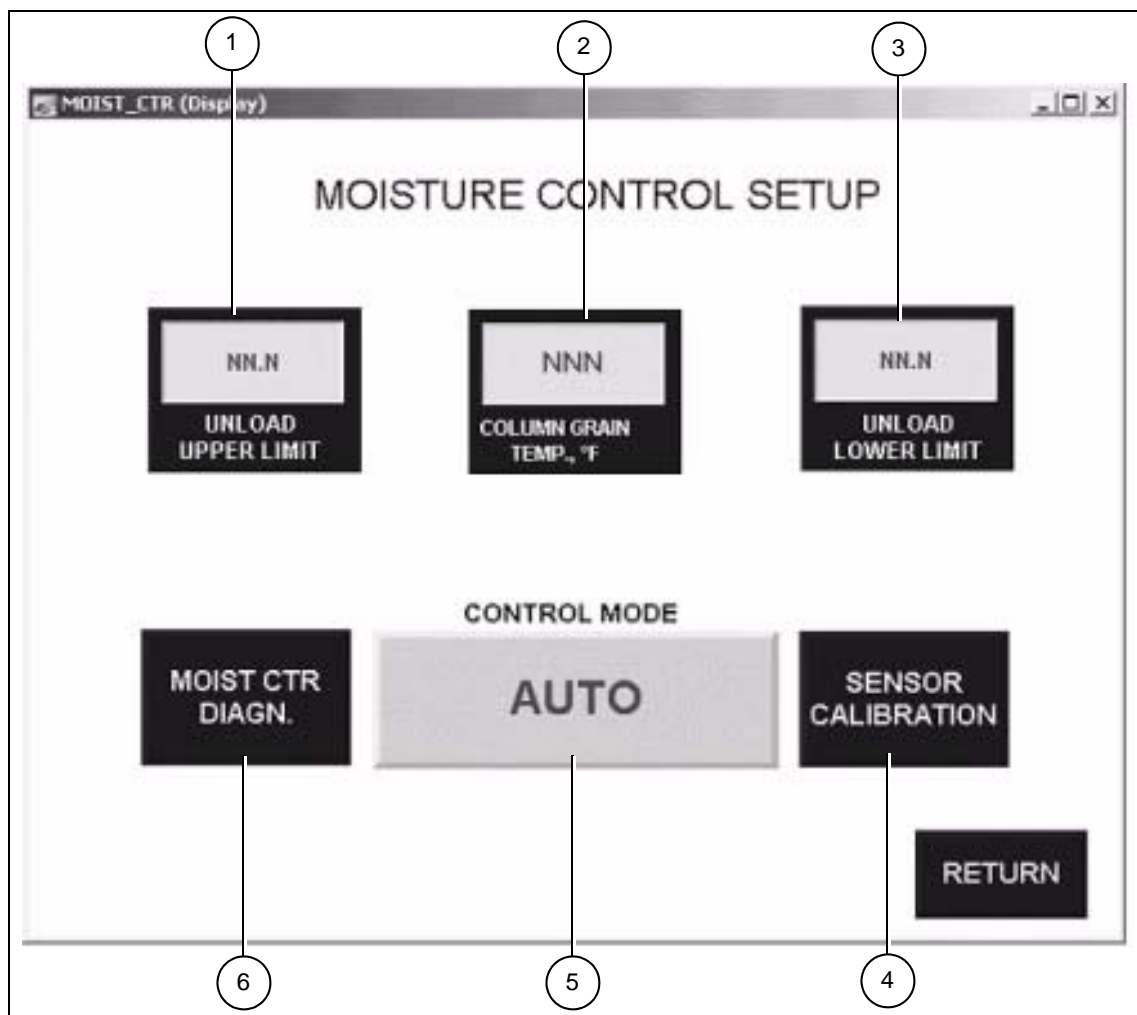

Figure 6B

1. **Unload upper limit** - Set maximum unload limit for the handling equipment.
2. **Current column grain temperature** - From the end of the drying section.
3. **Unload lower limit** - Set minimum unloading speed to keep moisture sampler covered with grain.
4. **Calibration button** - To calibrate moisture sensor.
5. **Control Mode button** - To toggle between AUTO and MANUAL.
6. **Moisture Control Diagnosis button** - To allow diagnostics.

Operation Procedure

1. Start the dryer and set dryer unload at the required speed.
2. Let the dryer run in manual until the column grain temperature has stabilized and the outgoing moisture is $\pm 2\%$ of the target moisture.
3. Calibrate wet and dry sensors against an accurate moisture meter.
 - a. Press “**SENSOR CALIBRATION**” in the moisture control set-up screen.
 - b. Adjust the moisture sensor offset to compensate for differences between the average sample reading and the on-screen reading.
 - c. Example: If the dryer is reading 15.0% and the average sample is 14.0%, alter the offset to -1.0%.

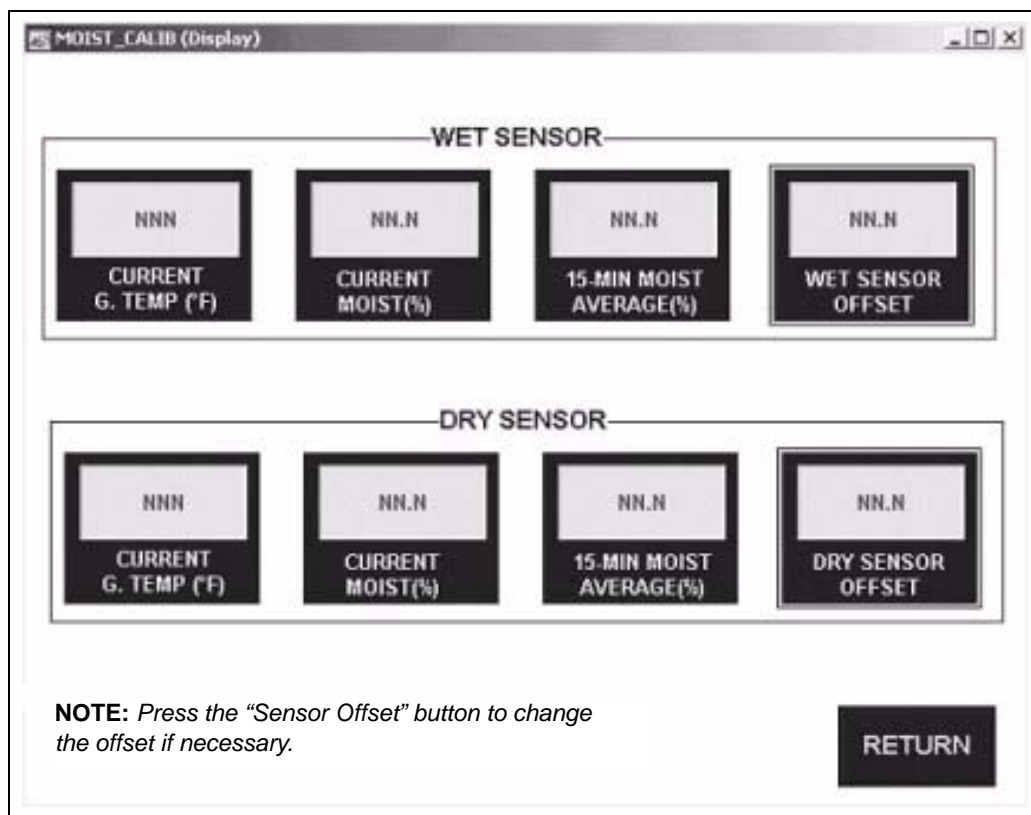

Figure 6C

6. Tri-Point Moisture Controller

- d. Calibrate three (3) times per day.
 - e. Clean the sensor regularly.
 - f. Grain must flow freely over the sensor.
4. Check or change the target moisture from the main screen.
 - a. Press “**MOIST CONTROL**” to access set-up screen.
 5. Check upper/lower unloading limits and change them if needed.
 6. Press the “**CONTROL MODE**” (moisture control set-up screen) and set mode to **AUTO**. The moisture controller will start adjusting the unload rate between the upper and lower limits of the unload speed to maintain the moisture coming out of the dryer.

Alarms

The controller checks the sensors and control status regularly. If abnormal conditions are detected, an alarm will go OFF and a message will come up on the main screen. **The dryer will be shut down.**

Alarm	Causes	Solution
Moisture out of range - Outgoing moisture has deviated by more than 2.5% from set point for more than one hour (AUTO mode only).	<ol style="list-style-type: none"> 1. Sensor box plugged/sensor was not covered by grain. 2. Dry sensor out of calibration. 3. Large fluctuation in wet grain moisture. 	<ol style="list-style-type: none"> 1. Clear the sampler and sensor box. 2. Calibrate the sensor. 3. Run in MANUAL for one pass.
Dry sensor error - Sensor reading is less than 6% or higher than 40%.	<ol style="list-style-type: none"> 1. Bad wiring. 2. Bad sensor. 3. Bad circuit board. 	<ol style="list-style-type: none"> 1. Check connection. 2. Change the sensor. 3. Change the circuit board.
Dry grain temperature out of range (0-300F).	<ol style="list-style-type: none"> 1. Bad wiring. 2. Bad sensor. 3. Bad circuit board. 	<ol style="list-style-type: none"> 1. Check connection. 2. Change the sensor. 3. Change the circuit board.
Wet sensor error - Sensor reading is less than 6% or higher than 40%.	<ol style="list-style-type: none"> 1. Bad wiring 2. Bad sensor 3. Bad circuit board 	<ol style="list-style-type: none"> 1. Check connection. 2. Change the sensor. 3. Change the circuit board.
Wet grain temperature out of range (0-300°F).	<ol style="list-style-type: none"> 1. Bad wiring. 2. Bad sensor. 3. Bad circuit board. 	<ol style="list-style-type: none"> 1. Check connection. 2. Change the sensor. 3. Change the circuit board.
Column grain temperature RTD out of range (0-300°F).	<ol style="list-style-type: none"> 1. Bad wiring. 2. Bad sensor. 3. Bad circuit board. 	<ol style="list-style-type: none"> 1. Check connection. 2. Change the sensor. 3. Change the circuit board.

Access Drying History

1. Press the “**DATA LOG**” button (main screen).
2. Press the browse buttons to browse the History screen. The controller logs quarterly data up to 120 records (i.e. 30 hours) into the archive.

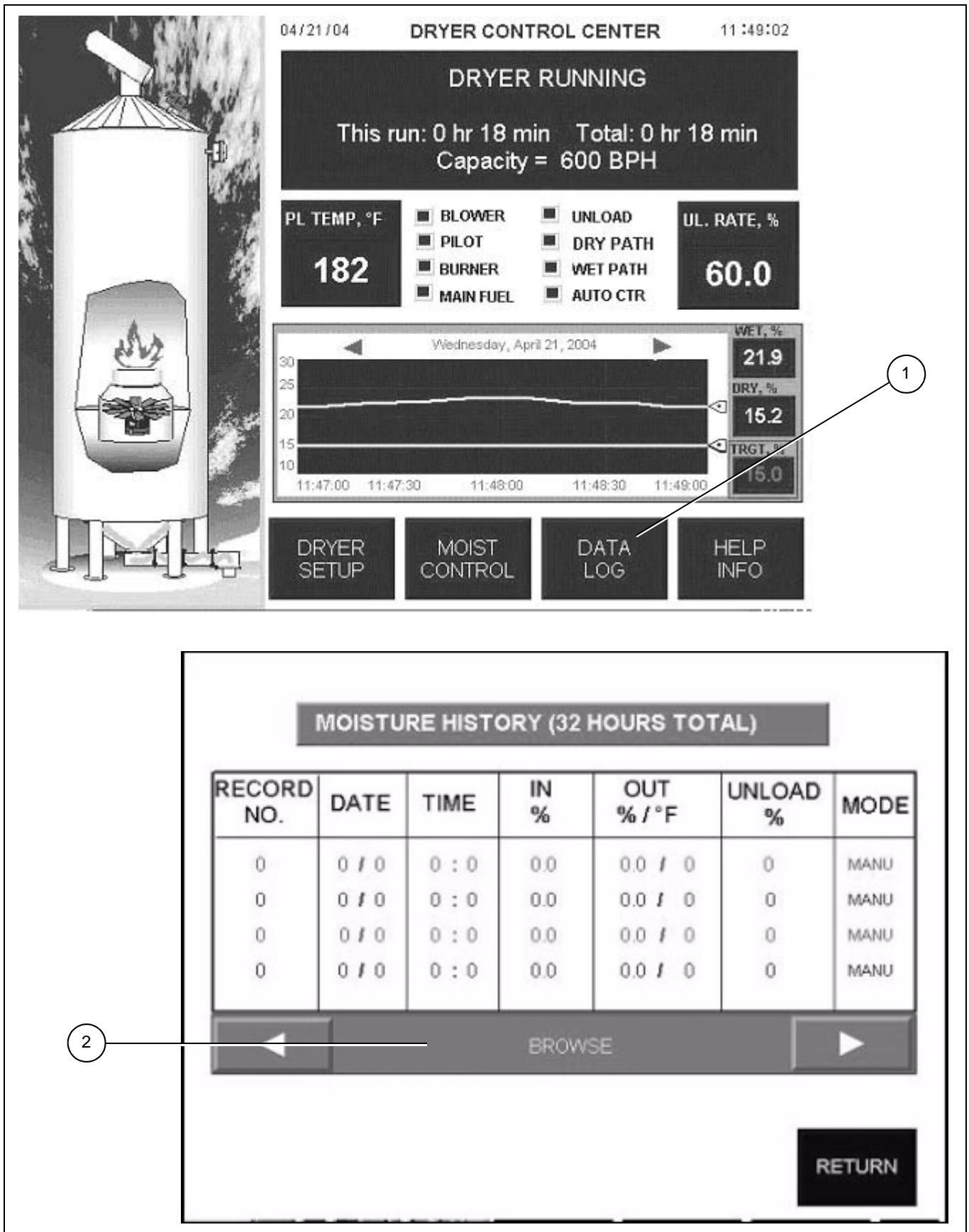

Figure 6D

7. Maintenance

Before and inspection, service or maintenance:



Shut off electrical power and lock.



Shut off fuel and lock.

Pre-Season Inspection and Service

Each season we recommend the checks,

Inspect	Action
Open power and control box and inspect for:	
Moisture.	1. Dry and address leak.
Rodent damage.	1. Replace/repair.
Foreign material.	1. Remove.
Loose terminal connections.	1. Tighten.
Damaged wiring	1. Replace.
Fans, motors and metering system	
Lubricate	1. Refer to lubrication table on Page 51 .
Belt tension	1. Re-tension if slipping.
Sweep unload (Zimmerman models)	1. Clean.
Hopper unload (GSI models)	2. Check for excessive wear. 3. Replace damaged parts.
Discharge cover plates	1. Must be in placed and clamped down. 2. Lube metering system access door cover hold-down latches.
Check burner	
	1. Remove any 'end of season' covers.
Air mixing plate	1. Clear all air holes.
Burner ports	1. Remove rust and debris (if required drill out with 2.2 mm drill).
Flame rod/spark igniter connections	1. Replace if damaged.

Pre-Season Inspection and Service (Continued)

Inspect	Action
Gas train	
Drain valve	1. Drain out condensate/dirt.
Modulating valve	1. Lubricate linkage. 2. Check butterfly operation in modulating valve.
Solenoid valves/pressure switches	1. Check and if required replace damaged connections.
Pressure test	1. Pressures with hand bellows to 350 mBar. 2. Check for leaks (repair). 3. Check slam-shut. 4. Check relief valve. 5. Check gas pressure gauges.
General	1. Inspect Bindicator grain level switches. 2. Inspect metering system access door cover seals.

Mid Season Inspection and Service

Inspect	Action
Moving parts.	1. Lubricate as per lubrication table on Page 51 .
Cooling section	1. Drying milo, check and clean every day.
	2. Other products, check and clean every week.
	3. Sweep down the cooling section sheets if necessary.
Heating section	1. Every day check hopper divider between heat and cool section. Must be clean and open.
Grain discharge area	1. Keep clean every day.
Plenum roof	1. After idle period clean off and stuck, wet grain.
Grain columns	1. Check loading evenly.
Upper outer sheets	1. Wash off/dry off any wet sludge. Stop loading system and allow grain to drop below dirty area. Allow dirt to dry and knock/sweep off.

In Case of Fire



Call emergency fire department.



Evacuate area.



If safe to do so, shut off power and fuel supply to entire dryer and auxiliary equipment.

1. Locate the area of the fire.
2. If safe to do so tackle fire with a fire extinguisher, water hose or by removing the burning material.
3. Be aware of secondary fires.
4. Emergency discharge slide gates permit grain column emergency dumping. (Bottom of each column and hopper discharge area.)
5. A number of fire extinguishers should be kept with the dryer.

End of Season Service

1. Empty the dryer. Do not use for storage.
2. Clean out the plenum roof grain cushion and plenum roof.
3. Clean the grain exchangers.
4. Clean the diving hopper between heating and cooling section.
5. Clean the cooling chamber floor.
6. Clean the metering drum floor. Rake out by hand through slide gates in the hopper bottom of the dryer.
7. Open the gas train drain valve (gas must be OFF).
8. Cover the burner with a tarpaulin or plastic to maintain a clean burner.

Lubrication Table

Location	Method	Lubrication	Interval
Metering drum drive shaft bearing. (GSI hopper bottom dryers only.)	1. Apply until grease shows past seal. 2. Wipe clean.	High quality; grade #2 lithium based grease.	Annual (start of season)
Accutrol (sweep unload) top and bottom drive bearings. (On Zimmerman flat bottom dryers only.)			
Accutrol (sweep unload) coupling hub. (On Zimmerman dryers.)	1. Remove the two (2) plugs from the cover. 2. Apply until grease shows through relief plug.		
Blower shaft bearings.	1. Count the grease gun pumps until grease shows past the seal. 2. Wipe clean. 3. Apply same amount for top bearing.	High quality; grade #2 lithium based grease.	Every 4 weeks.
Blower motor bearings.	1. Operate motor for 20 minutes. 2. Clean grease fitting. 3. Remove grease relief plug and apply required grease.	High quality, grade #2 lithium based grease.	1. 2 years (normal operation). 2. 8-10 months (continuous operation).
Metering variable speed drive motor.	1. Allow motor to run for 10 minutes before replacing relief hardware. <i>Do NOT overgrease.</i>		
12' Diameter Accutrol gearbox. (Zimmerman dryers only.)	1. Apply to first stage (upper) reduction mechanism through grease fitting provided (approximately 8 ml grease).	High quality, grade #2 lithium based grease.	1. Annually. 2. 3 years do complete change.
18' and 24' Diameter Accutrol gearbox. (Zimmerman dryers only.)	1. Maintain to upper red line on oil level gauge.	ISO VG 100 to 150 mineral-based oil.	1. Annual. 2. 10000 hours or 2 years do complete change.
Metering drum gearbox. (GSI hopper bottom dryers only.)	1. Fill to check plug.	ISO VG 220 mineral-based oil.	

8. Troubleshooting

1. Most electrical or operating problems are displayed on the screen.
2. Ensure correct supply voltage.
3. Control circuits are 120V AC.
4. Safety circuits are 24V DC.

Troubleshooting - Drying Issues

Problem	What to do
Low dryer capacity.	<ol style="list-style-type: none"> 1. Check to make sure the dryer is always full of grain. 2. Check all grain columns to make sure they are all moving. 3. Check outside dryer screen for dirt build up. Clean if necessary.
Grain moisture discharges too wet.	<ol style="list-style-type: none"> 1. Reduce unload rate. 2. Or increase drying temperature.
Grain moisture discharges too dry.	<ol style="list-style-type: none"> 1. Increase unload rate. 2. Or decrease drying temperature.
Grain moisture discharges inconsistently.	<ol style="list-style-type: none"> 1. Check that plenum temperature is being held consistent. 2. Check for widely varying incoming moistures. 3. Check for plugged grain columns. 4. Verify that an adequate supply of grain is being provided to the dryer to maintain a grain seal within the dryer.
Burnt or scorched kernels appear during drying.	<ol style="list-style-type: none"> 1. Some varieties of grain or frost damaged grain are sensitive to higher drying temperatures. Lower drying temperatures. 2. If dryer is equipped with an external LP vaporizer, ensure that liquid propane is not passing through the vaporizer and going to the dryer.
Grain not moving through grain columns.	<ol style="list-style-type: none"> 1. Check the dryer for fines build up within the column. Empty if necessary. 2. Do not leave the dryer full for extended periods of time or during rainy weather without occasionally moving grain through it.

Troubleshooting - Burner

Problem	What to do
Pilot will not light.	<ol style="list-style-type: none"> 1. Check the gas shut off valve is open. 2. Check overpressure shut off valve is open. 3. Check the pressure gauge located in the pilot line. 4. Check for click from pilot valve to indicate opening. 5. Disconnect pilot line from pilot solenoid. Blow line out with compressed air. 6. Refit the pilot line and adjust of flow of gas by adjusting flow. 7. Check voltage at pilot solenoid (120 VAC). 8. Check voltage at spark transformer (120 VAC). 9. Check burner control is not locked out. Re-set. 10. Check pilot area on burner. Clean if necessary. 11. If pilot area is hot (pilot lit but did not prove), check flame rod wiring/replace flame rod. 12. Check flame rod is not shorting to earth. 13. If pilot area is cold, replace spark plug/check HT lead/adjust spark gap. 14. If pilot still does not light replace burner control.
Pilot lights but main burner will not light.	<ol style="list-style-type: none"> 1. Check for water in gas train by opening drain valve. 2. Check main valves are opening (indicator lights on solenoid body). 3. Check burner ports are clean. 4. Check burner pressure.
Dryer will not reach operating temperature.	<ol style="list-style-type: none"> 1. Check modulating valve. 2. Check gas pressure. 3. Turn OFF gas and drain gas train.
Dryer loses flame at regular intervals while running.	<ol style="list-style-type: none"> 1. Check connections to flame rod. 2. Check flame rod is not touching burner. 3. Check pressure is stable.
Modulating valve does not open.	<ol style="list-style-type: none"> 1. Check operation of modulating valve. Check 120 VAC to black and white wires. 2. Short between "F" and "-" terminal to check motor drives fully open. 3. Check plenum set point.
Dryer not reaching temperature.	<ol style="list-style-type: none"> 1. Check dryer is completely fully. 2. Check burner pressures. 3. Check modulating valve function.

8. Troubleshooting

Troubleshooting - General

Problem	What to do
Control power switch will not light.	<ol style="list-style-type: none">1. Check main circuit breaker.2. Check fuses "F1", "F2", "F3" in power box.3. Check circuit breaker "CB-04" in power box.4. Check MicroLogix PLC in control box.
Dryer shuts down, red light lights and horn sounds, display shows: "OVERHEAT AT _____" "POSSIBLE FIRE".	<ol style="list-style-type: none">1. Follow procedure for possible fire.2. Check for a plugged or slow moving grain column.
Message: "UNLOAD DRIVE FAULT".	<ol style="list-style-type: none">1. Indicates that the metering system inverter drive has tripped.2. Check for plugged metering drum or Accutrol metering system.3. Reset drive by turning OFF the main circuit breaker for 15 seconds, or by pressing the "Stop" button on the inverter.
Message: "CONTACT FAILED TO CLOSE" "DRYCONVEYOR" "WET CONVEYOR" or any auxiliary starter.	<ol style="list-style-type: none">1. Indicates that any overload has occurred in the item indicated.2. Reset the overload of the starter indicated in the power panel and fix the overload conditions.
Message: "OVERLOAD TRIPPED" "BLOWER ___ STARTER".	<ol style="list-style-type: none">1. Indicates that any overload has occurred in the item indicated.2. Reset the overload of the starter indicated in the power panel and fix the overload conditions.

Troubleshooting - OIU (Screen) Messages

Message	What to do
Lost comm. to micro	Cycle the power
Overheat at top left possible fire	Check overheat condition and term. 101
Overheat at top right possible fire	Check overheat condition and term. 102
Overheat at middle left possible fire	Check overheat condition and term. 103
Overheat at middle right possible fire	Check overheat condition and term. 104
Overheat at lower left possible fire	Check overheat condition and term. 105
Overheat at lower right possible fire	Check overheat condition and term. 106
Overheat at inside left possible fire	Check overheat condition and term. 107
Overheat at inside right possible fire	Check overheat condition and term. 108
Overheat at plenum possible fire	Check overheat condition and term. 109
Overload tripped tri-starter	Check term. 300
Overload tripped blower 1 starter	Check term. 301
Overload tripped blower 2 starter	Check term. 302
Overload tripped blower 3 starter	Check term. 303
Overload tripped blower 4 starter	Check term. 304
Auxiliary stuck closed tri-starter	Check term. 200
Auxiliary stuck closed blower 1 starter	Check term. 201
Auxiliary stuck closed blower 2 starter	Check term. 202
Auxiliary stuck closed blower 3 starter	Check term. 203
Auxiliary stuck closed blower 4 starter	Check term. 204
Auxiliary contact failed to close tri-starter	Check term. 200
Auxiliary contact failed to close blower 1 starter	Check term. 201
Auxiliary contact failed to close blower 2 starter	Check term. 202
Auxiliary contact failed to close blower 3 starter	Check term. 203
Auxiliary contact failed to close blower 4 starter	Check term. 204
Switch open air pressure switch 1	Check term. 205
Switch open air pressure switch 2	Check term. 206
Switch open air pressure switch 3	Check term. 207
Switch open air pressure switch 4	Check term. 306
Switch open air pressure switch of combustion blower	Check term. 115
Lost flame	Check BCU and term. 114
Switch stuck closed Maxon valve	Check term. 113

8. Troubleshooting

Troubleshooting - OIU (Screen) Messages (Continued)

Message	What to do
Flame detected while burner is OFF.	Check if pilot or Maxon valves stuck open and check flame rod, BCU and term. 114.
High gas pressure switch open	Check term. 111
Low gas pressure switch open make sure main gas valve is ON.	Check gas pressure and term. 110
High gas pressure switch open gas pressure too high.	Check term. 111
Low gas pressure switch open gas pressure too low	Check term. 110
Maxon valves not turn ON	Reset and try again
Plenum temperature RTD circuit open or shorted	Check the RTD wiring
Grain temperature RTD circuit open or shorted	Check the RTD wiring
Auxiliary stuck closed oil pump starter	Check term. 307
Auxiliary stuck closed combustion blower starter	Check term. 308
Auxiliary contact failed to close oil pump starter	Check term. 307
Auxiliary contact failed to close combustion blower starter	Check term. 308
Plug switch open dry path plugged	Clear dry path and check term. 309
Plug switch open hopper plugged	Clear hopper and check term. 310
Unload drive fault	Check the drive and term. 208
Overload tripped dry conveyor	Check term. 305
Plug switch open wet path plugged	Clear wet path and check term. 311
Auxiliary stuck closed dry conveyor	Check term. 209
Auxiliary stuck closed auxiliary dry conveyor	Check term. 210
Auxiliary stuck closed dry leg	Check term. 211
Auxiliary stuck closed top dry conveyor	Check term. 212
Unload monitor proximity switch open	Check the unload device and term. 313
Auxiliary stuck closed auxiliary wet conveyor	Check term. 215
Auxiliary stuck closed wet leg	Check term. 214
Auxiliary stuck closed top wet conveyor	Check term. 213
Contact failed to close dry conveyor	Check term. 209
Contact failed to close auxiliary dry conveyor	Check term. 210
Contact failed to close dry leg	Check term. 211
Contact failed to close top dry conveyor	Check term. 212
Contact failed to close auxiliary wet conveyor	Check term. 215
Contact failed to close wet leg	Check term. 214
Contact failed to close top wet conveyor	Check term. 213
Bindicator error UBS closed while LBS still open	Check term. 314 and 315

Troubleshooting - OIU (Screen) Messages (Continued)

Message	What to do
Shut down out of grain occurred at — dry sensor error moisture signal out of range.	Check the sensor wiring
Dry sensor error grain temperature signal out of range	Check the sensor wiring
Wet sensor error moisture signal out of range	Check the sensor wiring
Wet sensor error grain temperature signal out of range	Check the sensor wiring
Column grain RTD sensor error RTD out of range	Check the sensor wiring
Shut down by moisture controller failed to maintain to the target	Try again w/ close supervision
Ready to start	Press the dryer control START
Ready to start blower	Turn blower switch to ON to start
Ready to start burner	Turn burner switch to ON to start
Out of grain	Will shut down in ___ seconds
Start unload now	Or will shut down ___ seconds
Dryer cooling off current grain temperature = ____	Blower will shut down in ____ seconds/*N:5 or turn the Blower switch OFF to shut down now.
Wet path not on	Turn load switch to MANUAL or AUTO to start.
Filling the dryer	Please wait...
Dryer is full	Press Control Stop button to reset alarm, then press Control Start button to re-start.
Emptying the dryer	Please wait...
No power to SLC Start checking please wait ___ seconds left Tri-Start ON ___ seconds left Starting blower 1 Starting blower 2 Starting blower 3 Starting blower 4 Purging ____ seconds left Open main fuel valves or will shut down in ____ seconds Ignition trial ____ seconds left	Pull E-Stop button out and check term. 100 for 24 VDC.
Firing valve limit switch open, open the firing valve Interlocked start dry conveyor first Interlocked start auxiliary dry conveyor first Interlocked start dry leg first Interlocked start top dry conveyor first Interlocked start auxiliary wet conveyor first Interlocked start wet leg first Interlocked start top wet conveyor first	Check term. 112

9. Tower Dryer Control Panel Wiring Diagrams

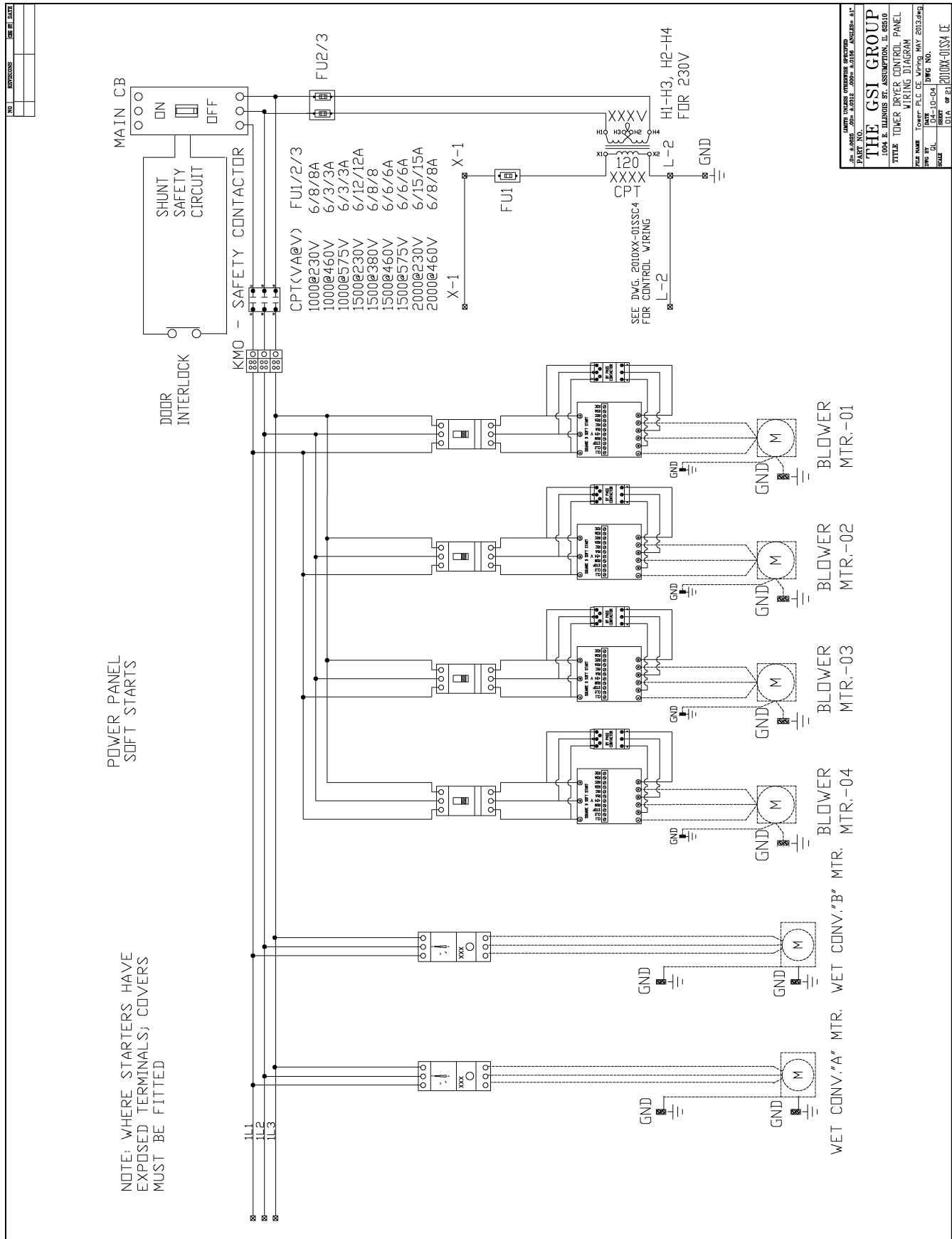

THE GSI GROUP	
104 E. ILLINOIS ST. ASSUMPTION, IL 62510	
TITLE TOWER DRYER CONTROL PANEL WIRING DIAGRAM	
DATE: Tower PLC CE Wiring, MAY 2013.dwg	SCALE: 1:1
DWG NO. 04-10-04	REV. NO. 01
ISSUED BY: [Signature]	
CHECKED BY: [Signature]	
DATE: 05/21/2013	

Figure 9A

9. Tower Dryer Control Panel Wiring Diagrams

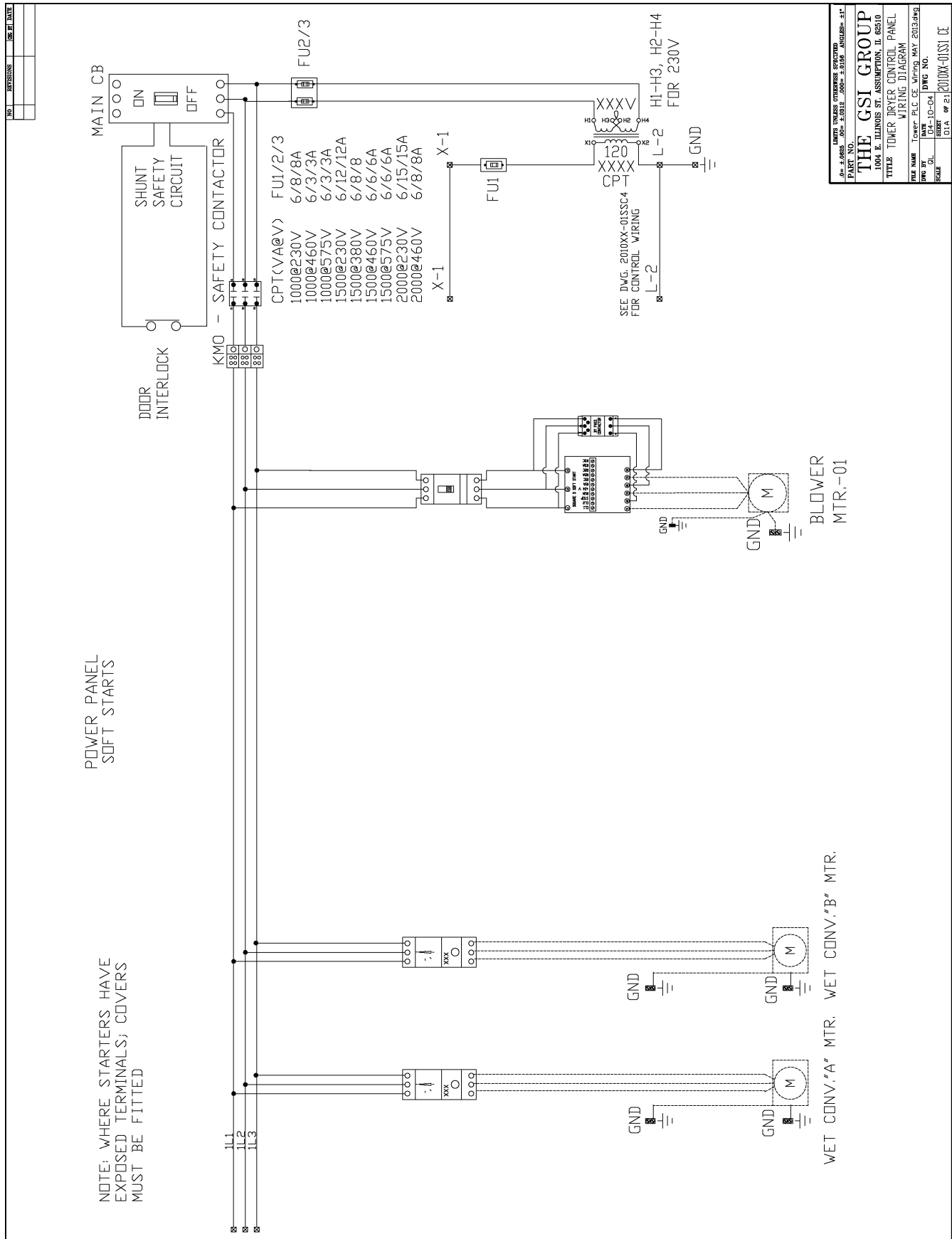

Figure 9C

9. Tower Dryer Control Panel Wiring Diagrams

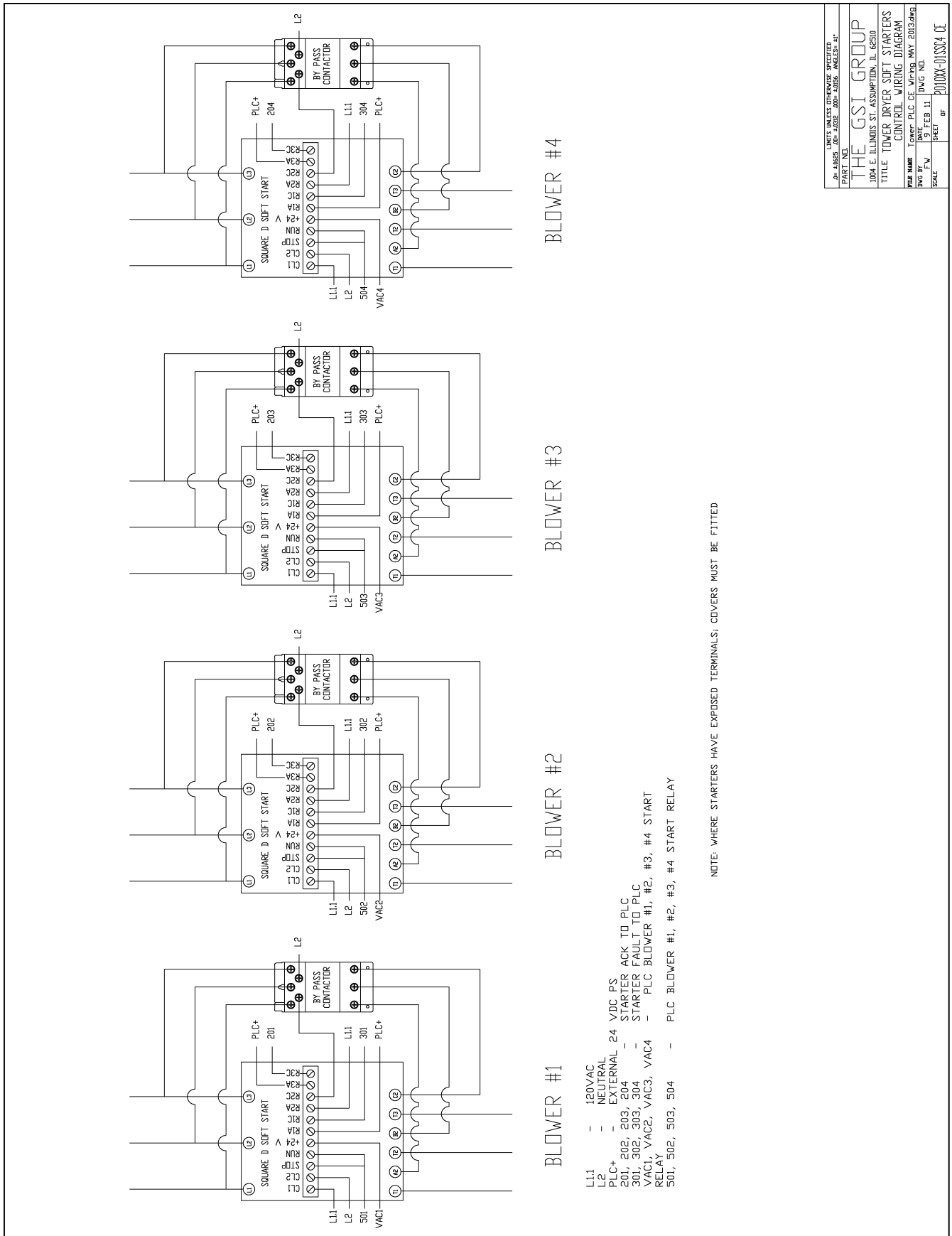
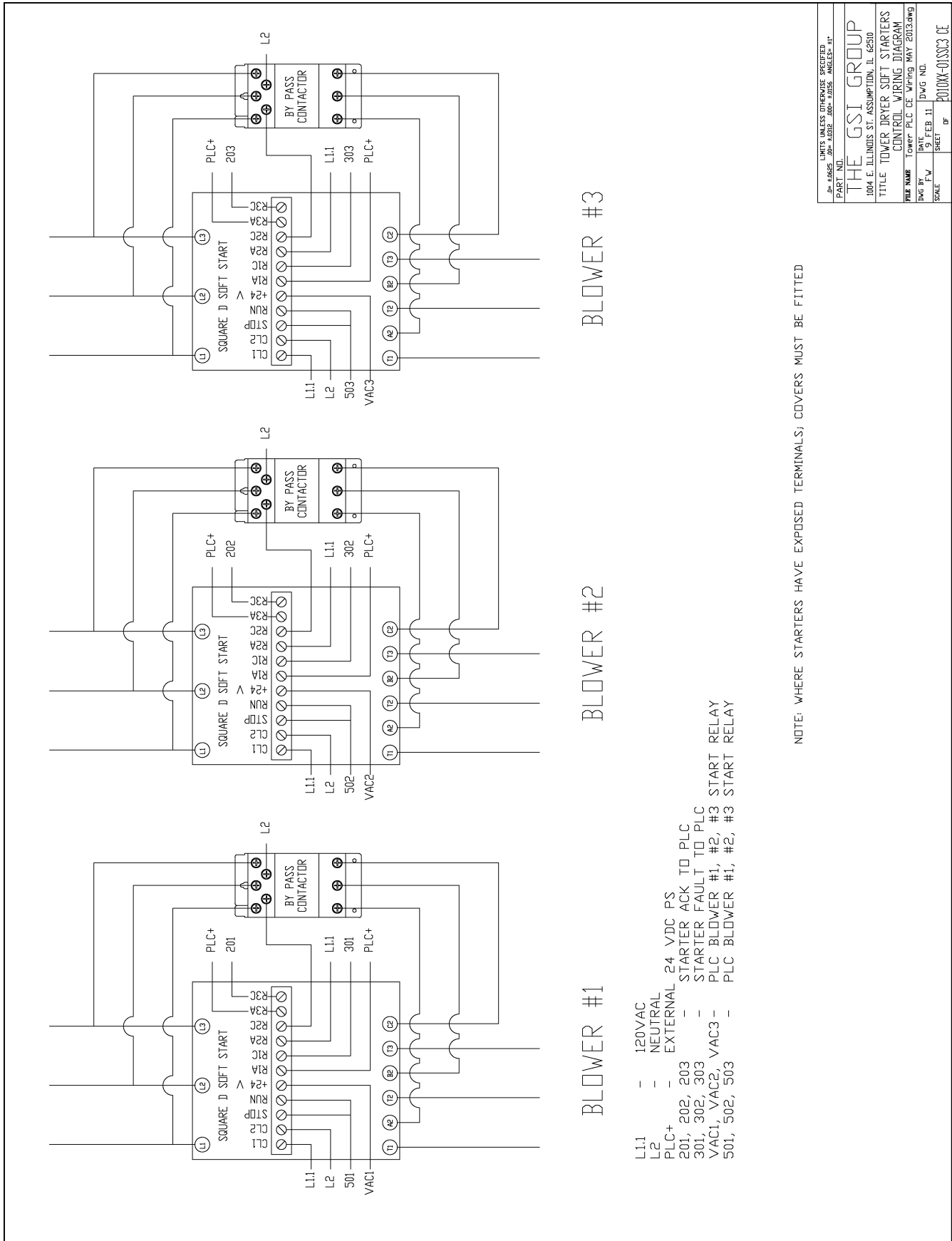

Figure 9D

9. Tower Dryer Control Panel Wiring Diagrams



UNITS IN LINES OVERLAP AS SPECIFIED	
PART NO.	1004 E. JLLINOIS ST. ASSUMPTION, IL 62510
THE GSI GROUP	
TITLE TOWER DRYER SOFT STARTERS	
CONTROL WIRING DIAGRAM	
FILE NAME	TOWER PLC CE WIRING MAY 2013.dwg
DWG BY	DATE
FV	9 FEB 11
SHEET	DWG NO.
3	2010W-015533 CE

Figure 9E

9. Tower Dryer Control Panel Wiring Diagrams

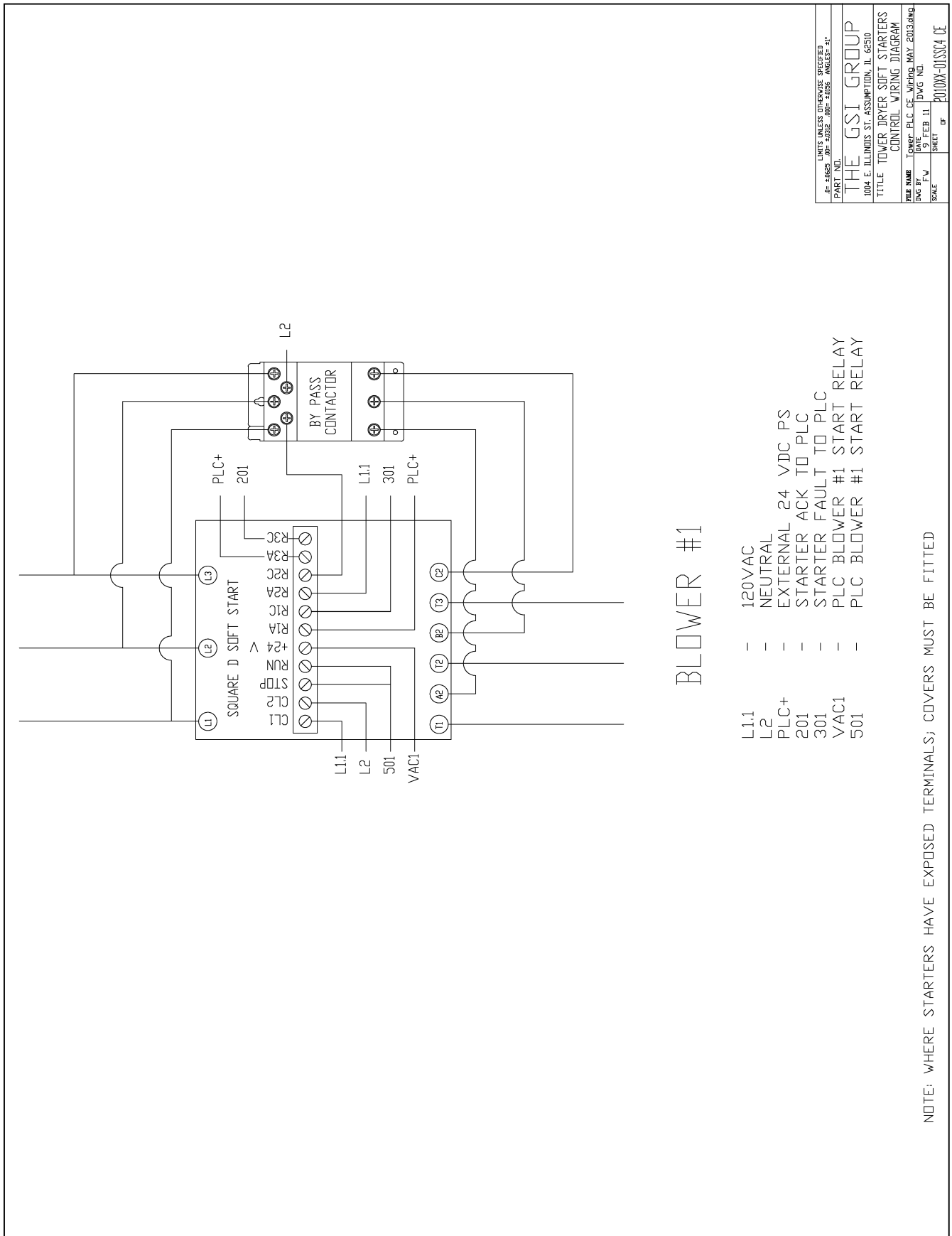

BLOWER #1

- 120VAC
- NEUTRAL
- EXTERNAL 24 VDC PS
- STARTER ACK TO PLC
- STARTER FAULT TO PLC
- PLC BLOWER #1 START RELAY
- PLC BLOWER #1 START RELAY

NOTE: WHERE STARTERS HAVE EXPOSED TERMINALS; COVERS MUST BE FITTED

LIMITS UNLESS OTHERWISE SPECIFIED			
PART NO.	JOB NO.	DATE	ANALYST
THE GSI GROUP			
1004 E. ILLINOIS ST. ASSUMPTION, IL 62510			
TITLE TOWER DRYER SOFT STARTERS			
CONTROL WIRING DIAGRAM			
FILE NAME	TOWER-PLC-CE	WIRING	MAY 2013.dwg
DWG. NO.	F.V.	FEB. 11	DWG. NO.
SCALE			SHEET
			OF 0100W-0155CA-CE

Figure 9F

9. Tower Dryer Control Panel Wiring Diagrams

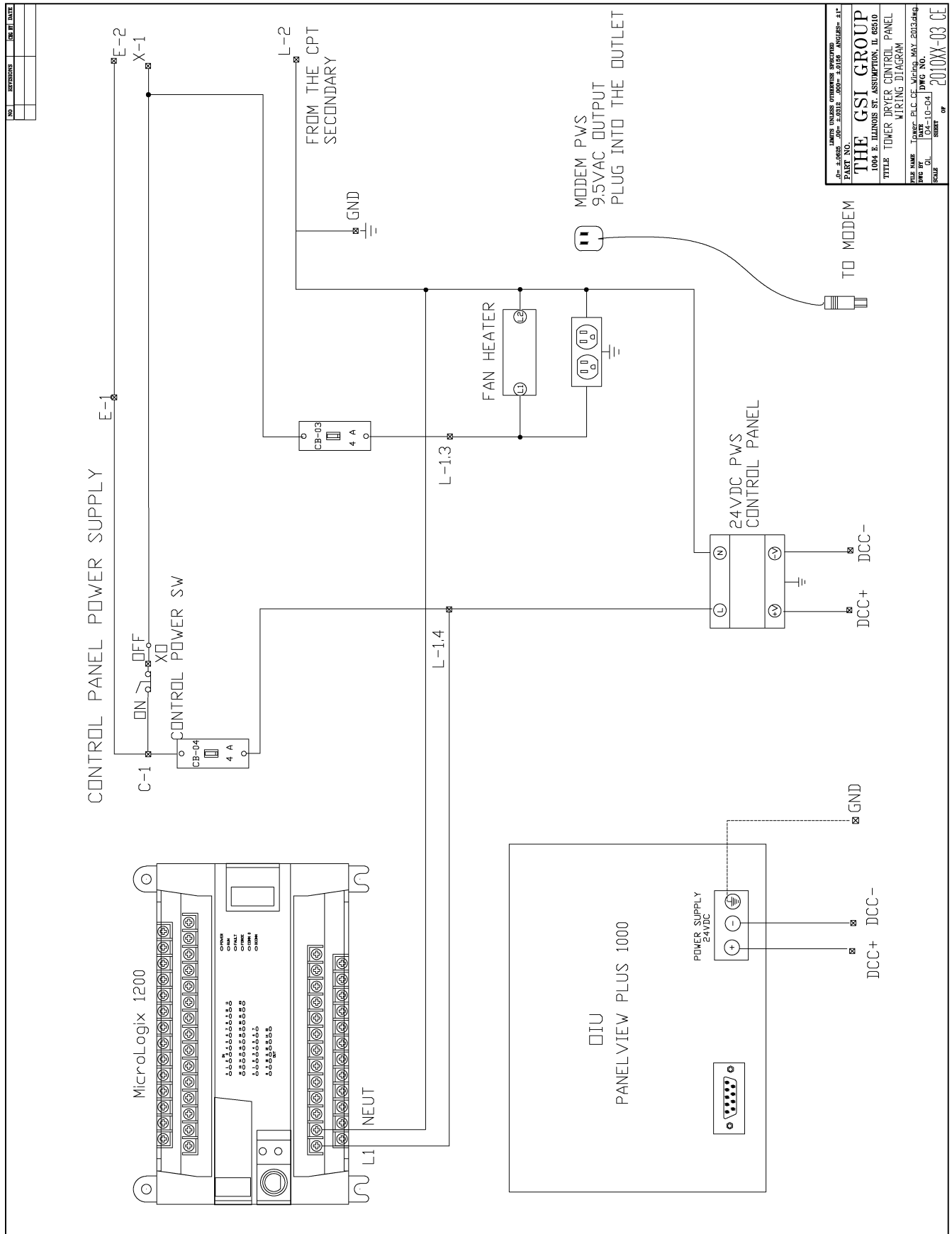

Figure 9G

9. Tower Dryer Control Panel Wiring Diagrams

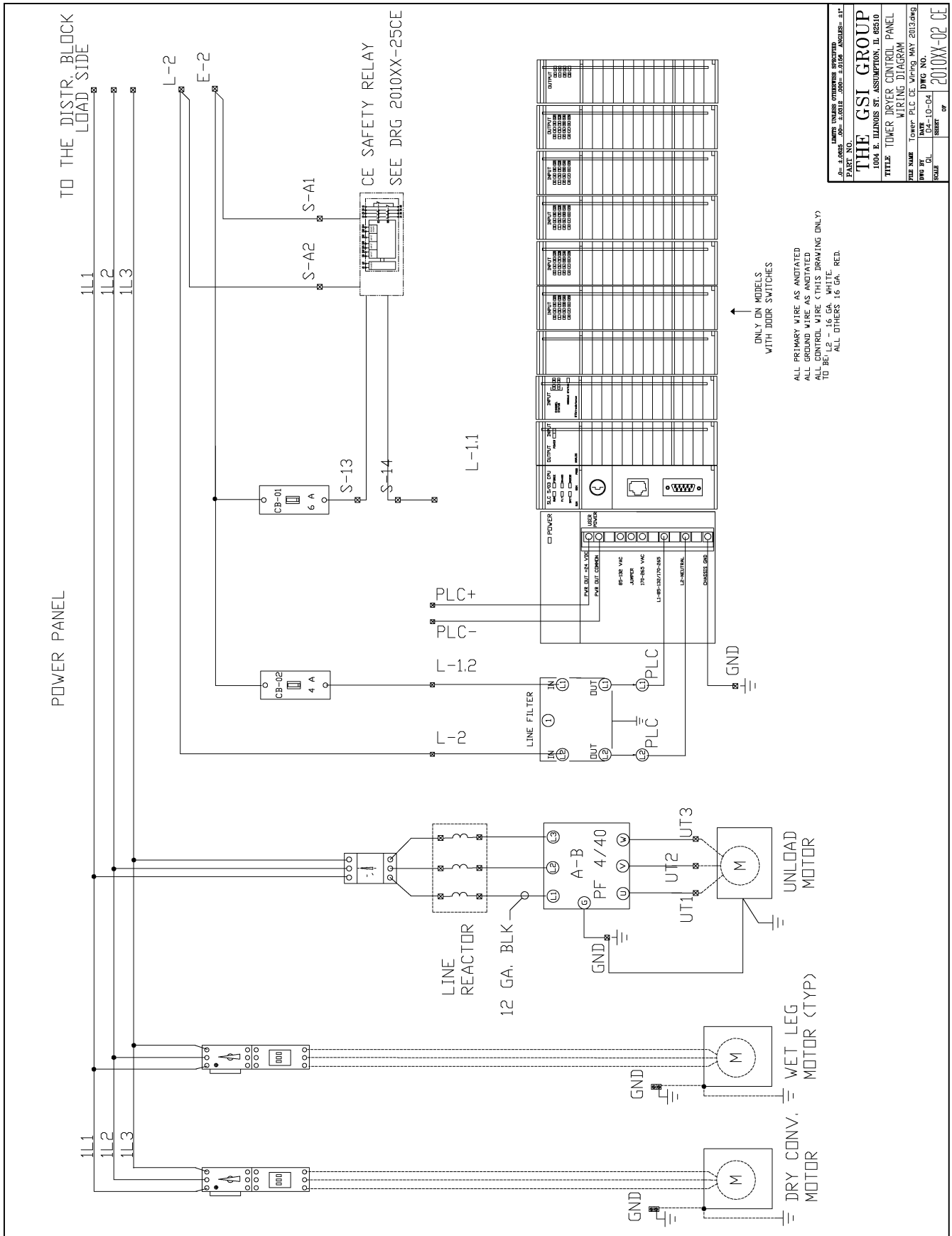
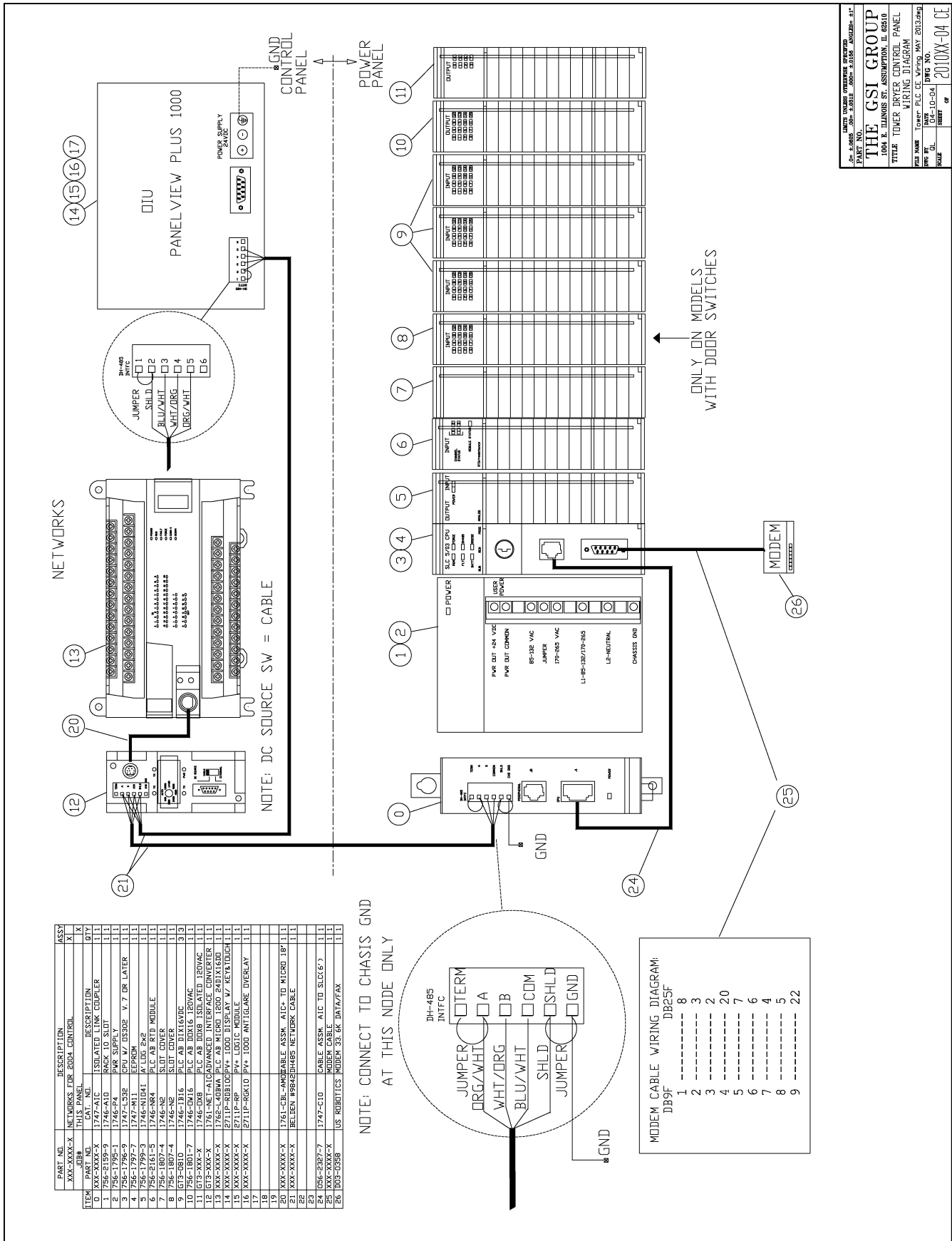

Figure 9H

9. Tower Dryer Control Panel Wiring Diagrams



DATE: 04-10-04
 PART NO.: 2010XX-04 CE
 THE GSI GROUP
 1004 E. ILLINOIS ST., ASSUMPTION, IL 62510
 TITLE: TOWER DRYER CONTROL PANEL WIRING DIAGRAM
 REV. NAME: Tower-PLC CE-Wiring MAY 2003/24g
 REV. NO.: 04-10-04
 SCALE: 1:1

Figure 91

9. Tower Dryer Control Panel Wiring Diagrams

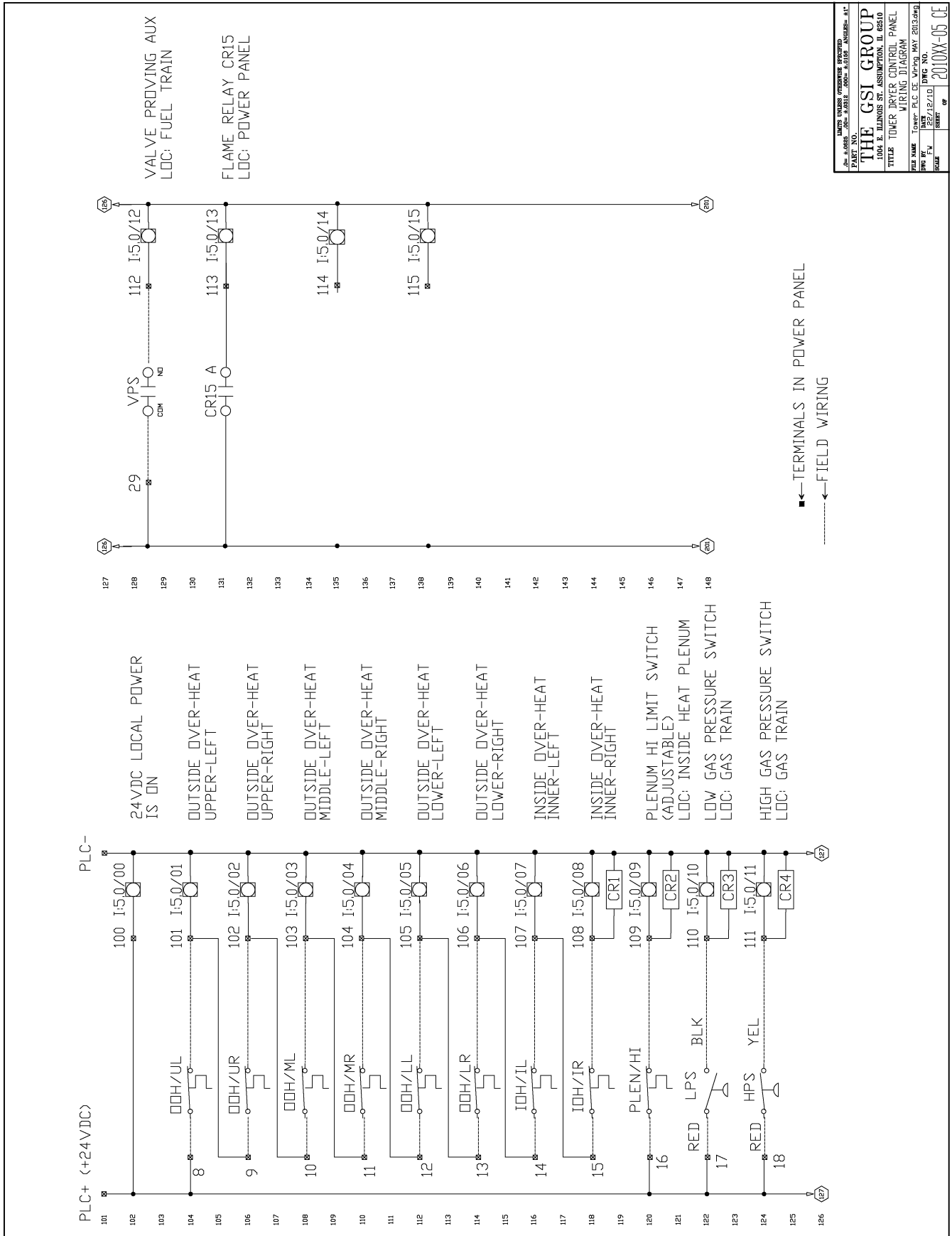

<small>THE GSI GROUP 1004 E. ILLINOIS ST. ASSUMPTION, IL 62610</small>	
THE GSI GROUP	
<small>PLC PART NO. 2010WX-05 CE</small>	
TOWER DRYER CONTROL PANEL WIRING DIAGRAM	
<small>DATE: 05/22/10</small>	<small>REV: 01</small>
<small>SCALE: 1/8" = 1'-0"</small>	<small>DATE: 05/22/10</small>
<small>BY: J. W. WILSON</small>	<small>CHK: J. W. WILSON</small>
<small>APP: J. W. WILSON</small>	<small>DATE: 05/22/10</small>

Figure 9J

9. Tower Dryer Control Panel Wiring Diagrams

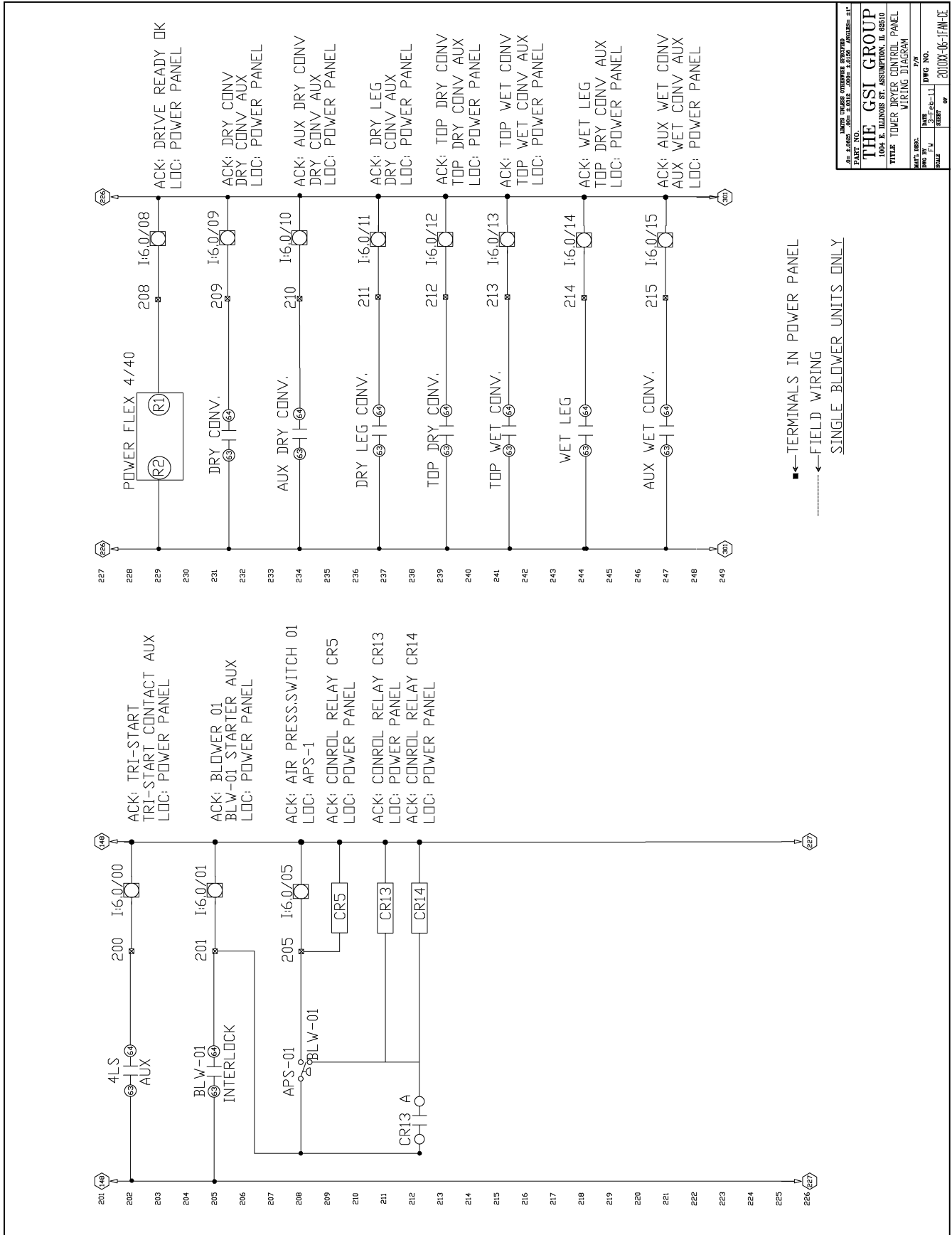
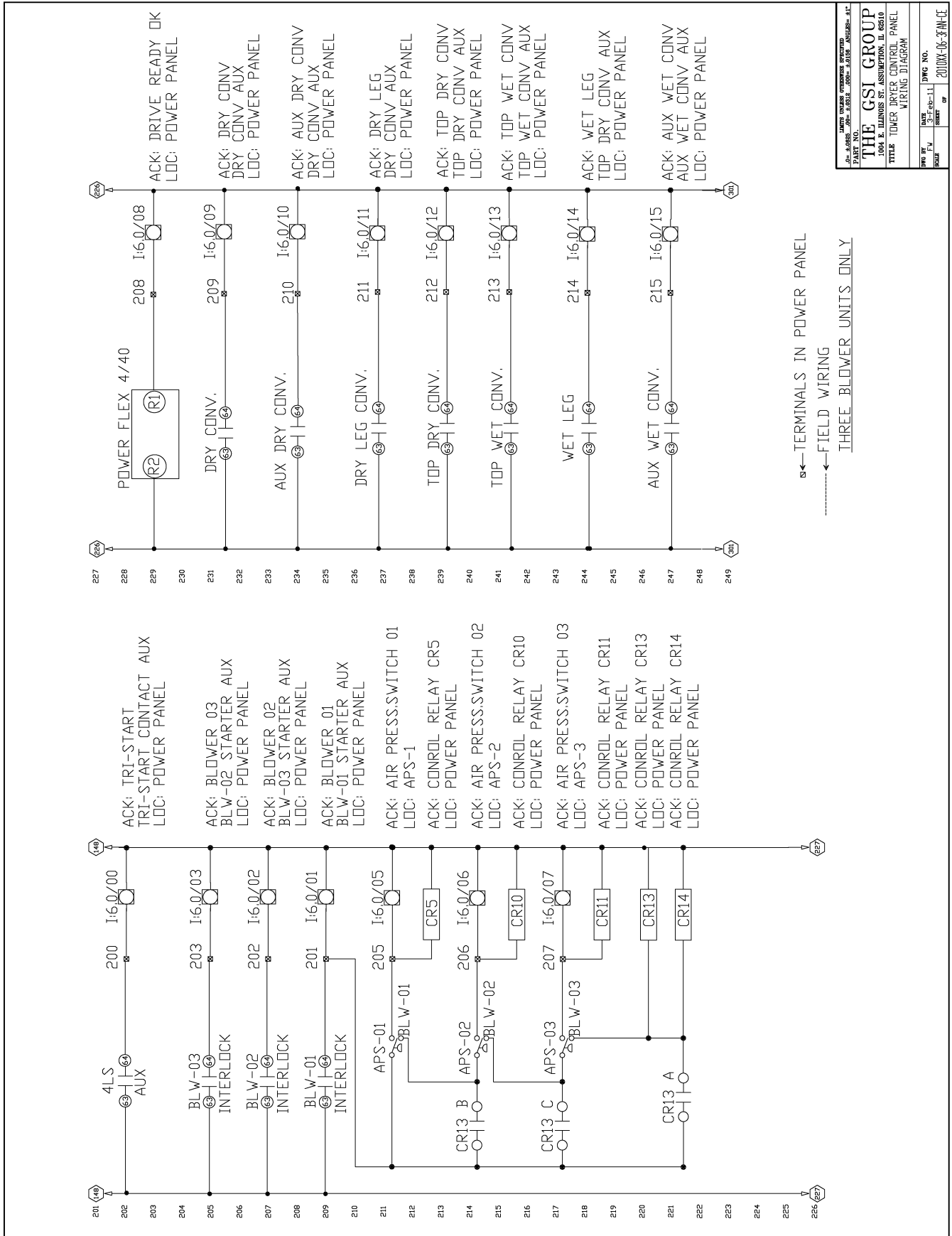

Figure 9K

9. Tower Dryer Control Panel Wiring Diagrams



THE GSI GROUP 100 & 110000 ST. ASSUMPTION, IL 60410 TITLE: TOWER DRYER CONTROL PANEL WIRING DIAGRAM	
DATE: 05-11-11 DRAWN BY:	DWG NO.: 2000X-05-3A-ACE

Figure 9L

9. Tower Dryer Control Panel Wiring Diagrams

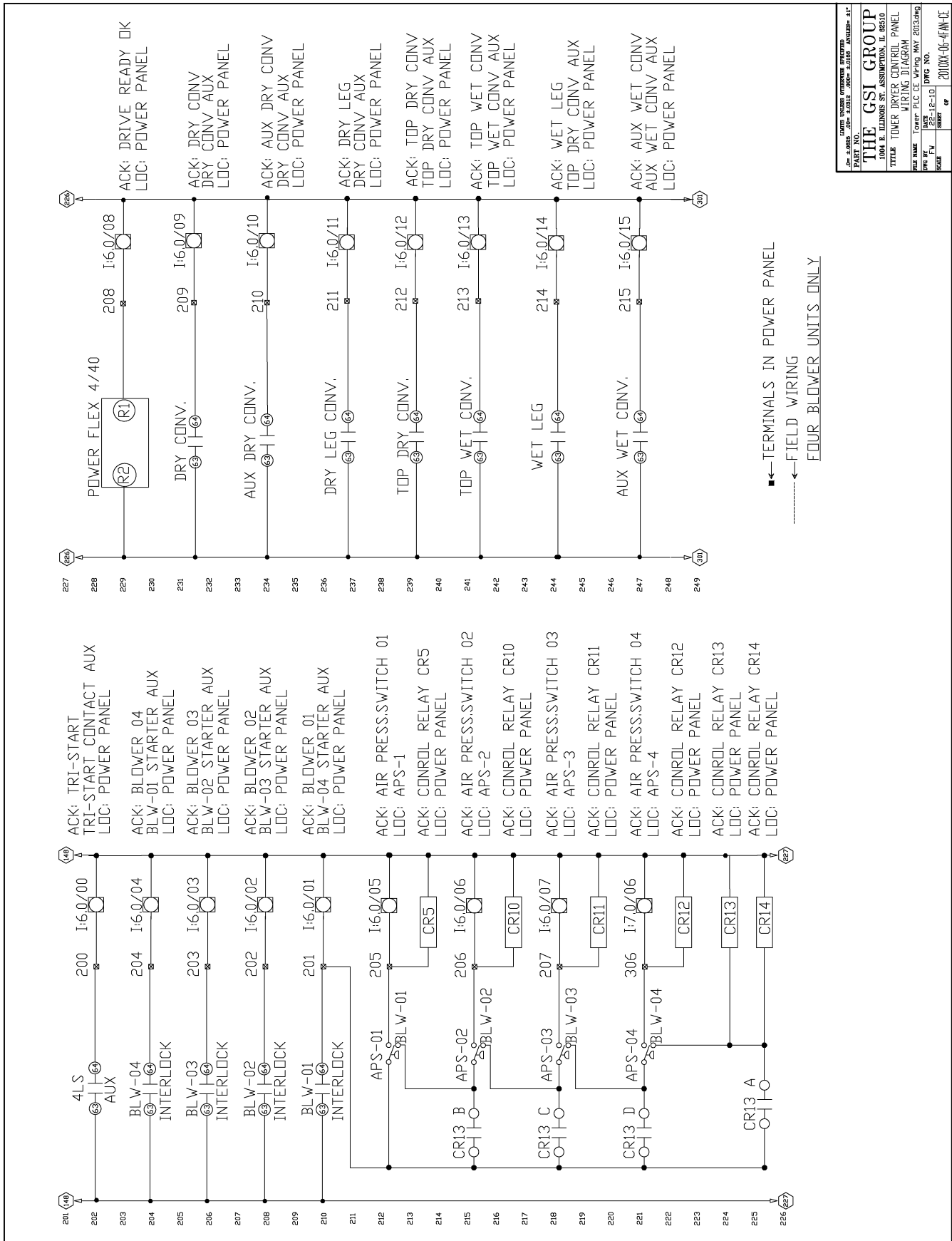

DATE	10/12/10	BY	W. J. BROWN
REV	001	DATE	10/12/10
THE GSI GROUP			
1004 E. TULLOHAN ST. ASSUMPTION, IL 62510			
TITLER TOWER DRYER CONTROL PANEL			
WIRING DIAGRAM			
FILE NAME	TOWER-PLC CE-WIRING-MAT-2010-09	DATE	10/12/10
PROJ. NO.	22-12-10	DRWG. NO.	01
SCALE	AS SHOWN	REVISION	201009-06-4FAN-CE

Figure 9M

9. Tower Dryer Control Panel Wiring Diagrams

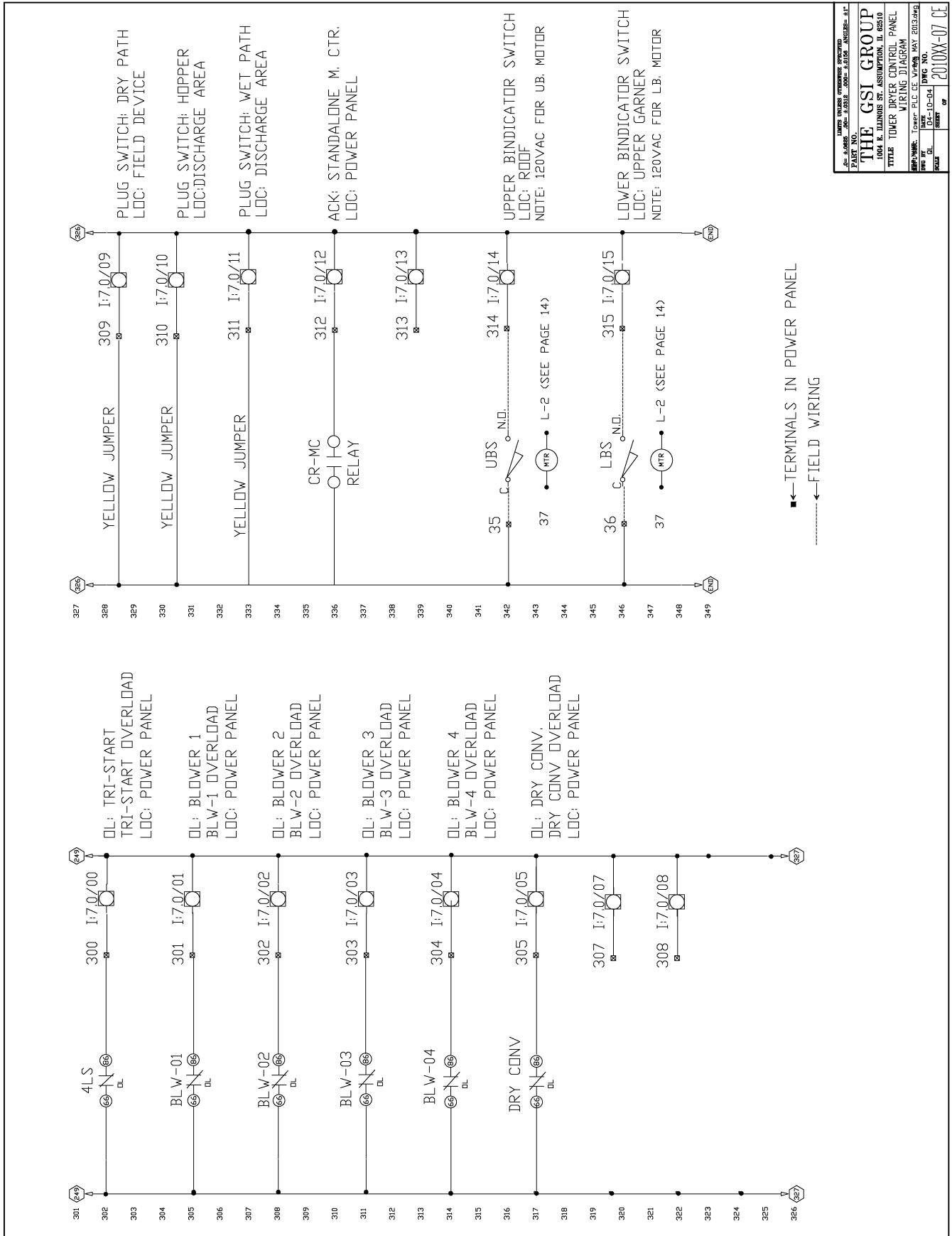

<small>THE GSI GROUP</small> <small>1004 E. ILLINOIS ST. ASSUMPTION, IL 62510</small> <small>TEL: 618-241-1111 FAX: 618-241-1112</small>	
THE GSI GROUP 1004 E. ILLINOIS ST. ASSUMPTION, IL 62510 TITLE: TOWER DRYER CONTROL PANEL WIRING DIAGRAM	
<small>REV. NO.</small> 001	<small>DATE</small> 0-01
<small>SCALE</small> 1:1	<small>DRG. NO.</small> 2010WX-07 CE

Figure 9N

9. Tower Dryer Control Panel Wiring Diagrams

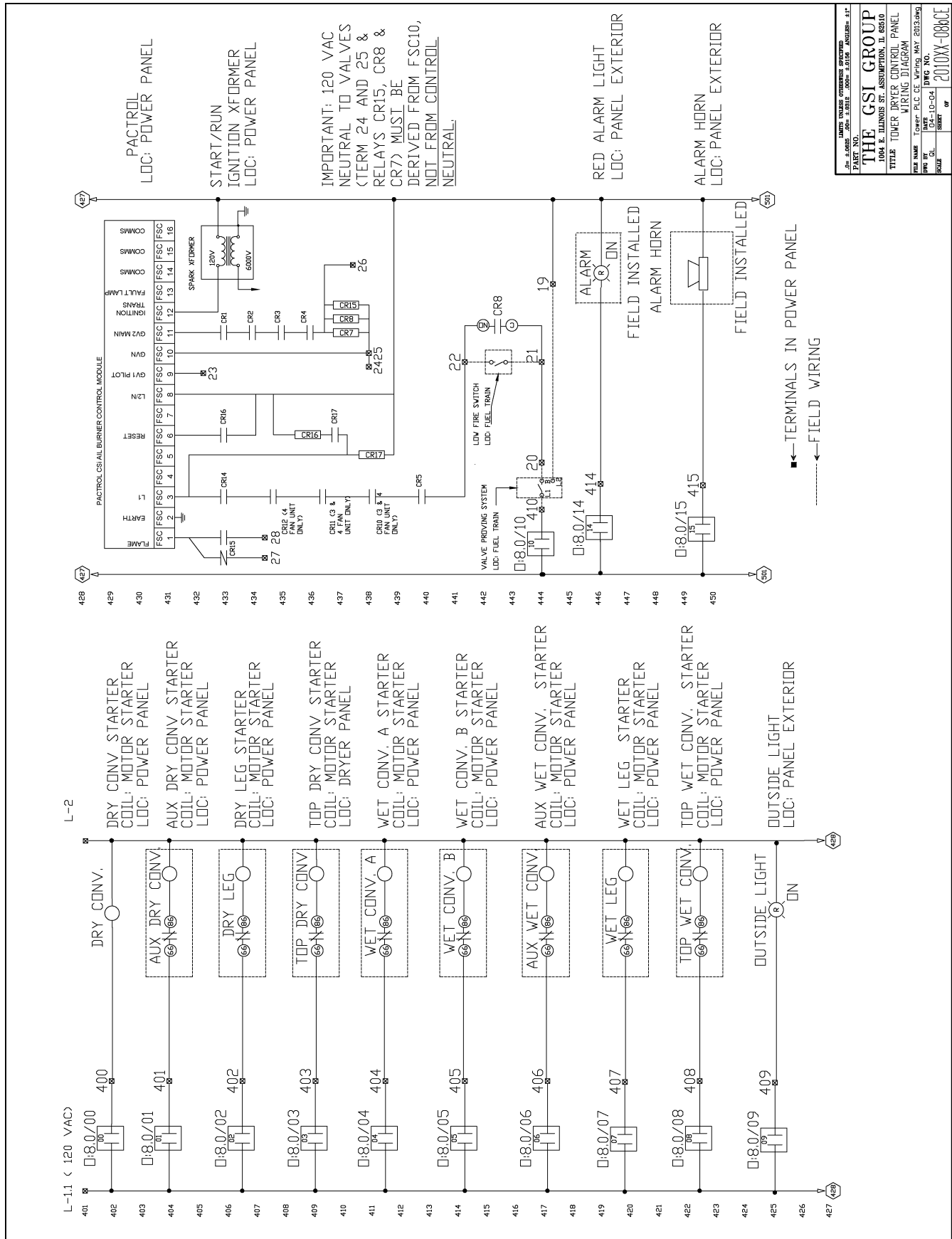

REV. NO.	DATE	BY	UNIT NO.
001	05/20/04	PLC	001
002	05/20/04	PLC	001
003	05/20/04	PLC	001
004	05/20/04	PLC	001
005	05/20/04	PLC	001
006	05/20/04	PLC	001
007	05/20/04	PLC	001
008	05/20/04	PLC	001
009	05/20/04	PLC	001
010	05/20/04	PLC	001
011	05/20/04	PLC	001
012	05/20/04	PLC	001
013	05/20/04	PLC	001
014	05/20/04	PLC	001
015	05/20/04	PLC	001
016	05/20/04	PLC	001
017	05/20/04	PLC	001
018	05/20/04	PLC	001
019	05/20/04	PLC	001
020	05/20/04	PLC	001
021	05/20/04	PLC	001
022	05/20/04	PLC	001
023	05/20/04	PLC	001
024	05/20/04	PLC	001
025	05/20/04	PLC	001
026	05/20/04	PLC	001
027	05/20/04	PLC	001
028	05/20/04	PLC	001
029	05/20/04	PLC	001
030	05/20/04	PLC	001
031	05/20/04	PLC	001
032	05/20/04	PLC	001
033	05/20/04	PLC	001
034	05/20/04	PLC	001
035	05/20/04	PLC	001
036	05/20/04	PLC	001
037	05/20/04	PLC	001
038	05/20/04	PLC	001
039	05/20/04	PLC	001
040	05/20/04	PLC	001
041	05/20/04	PLC	001
042	05/20/04	PLC	001
043	05/20/04	PLC	001
044	05/20/04	PLC	001
045	05/20/04	PLC	001
046	05/20/04	PLC	001
047	05/20/04	PLC	001
048	05/20/04	PLC	001
049	05/20/04	PLC	001
050	05/20/04	PLC	001

Figure 90

9. Tower Dryer Control Panel Wiring Diagrams

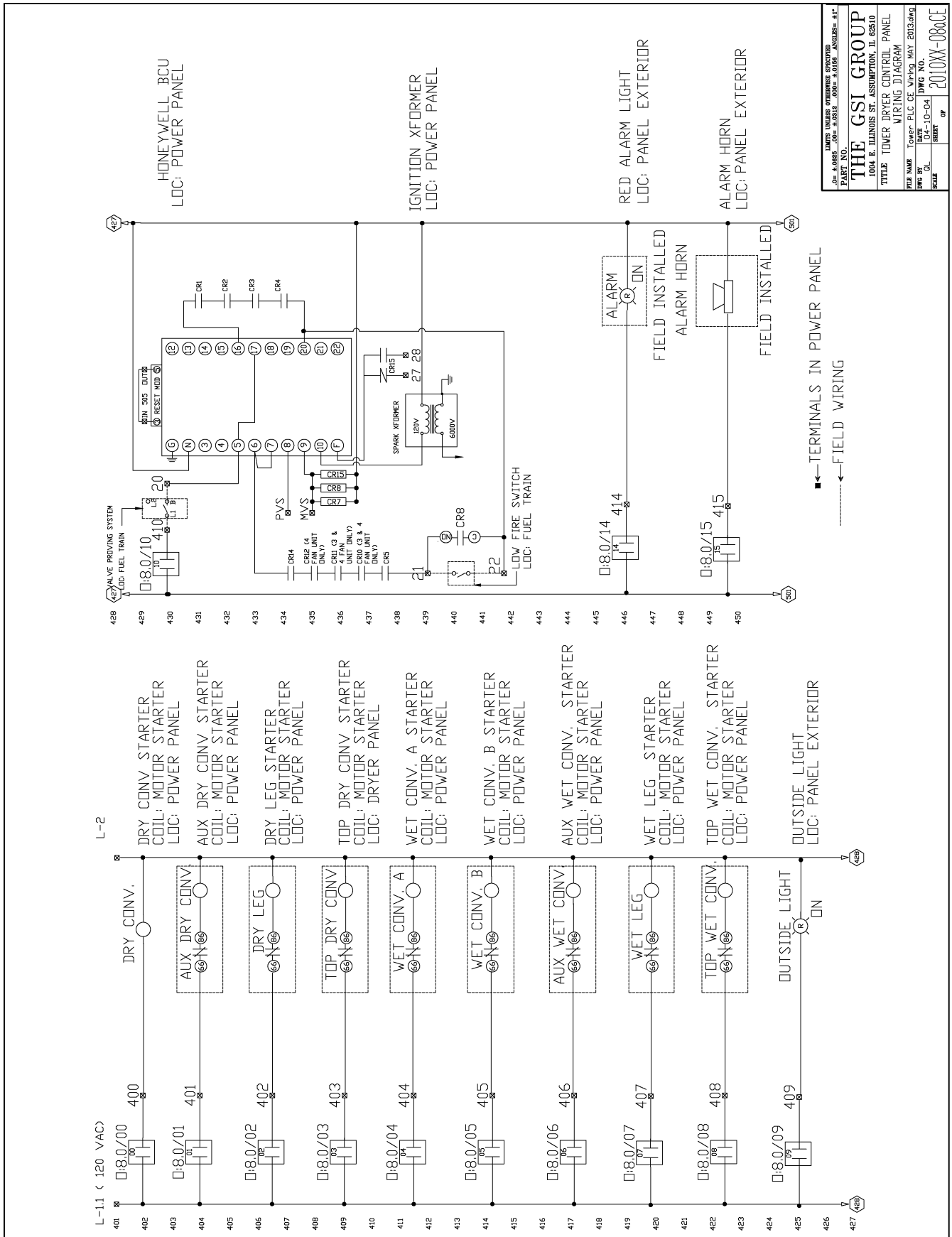

Figure 9P

9. Tower Dryer Control Panel Wiring Diagrams

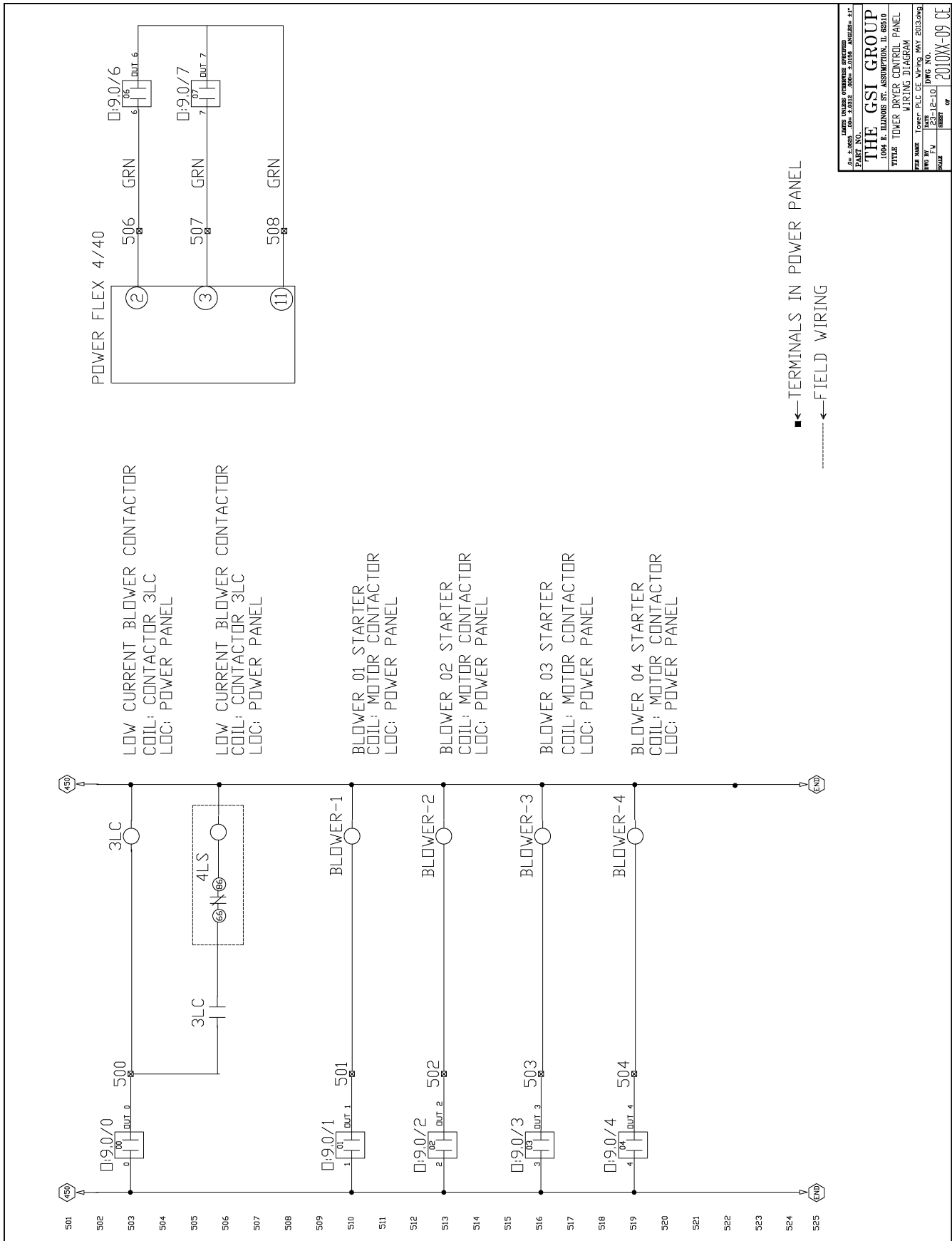
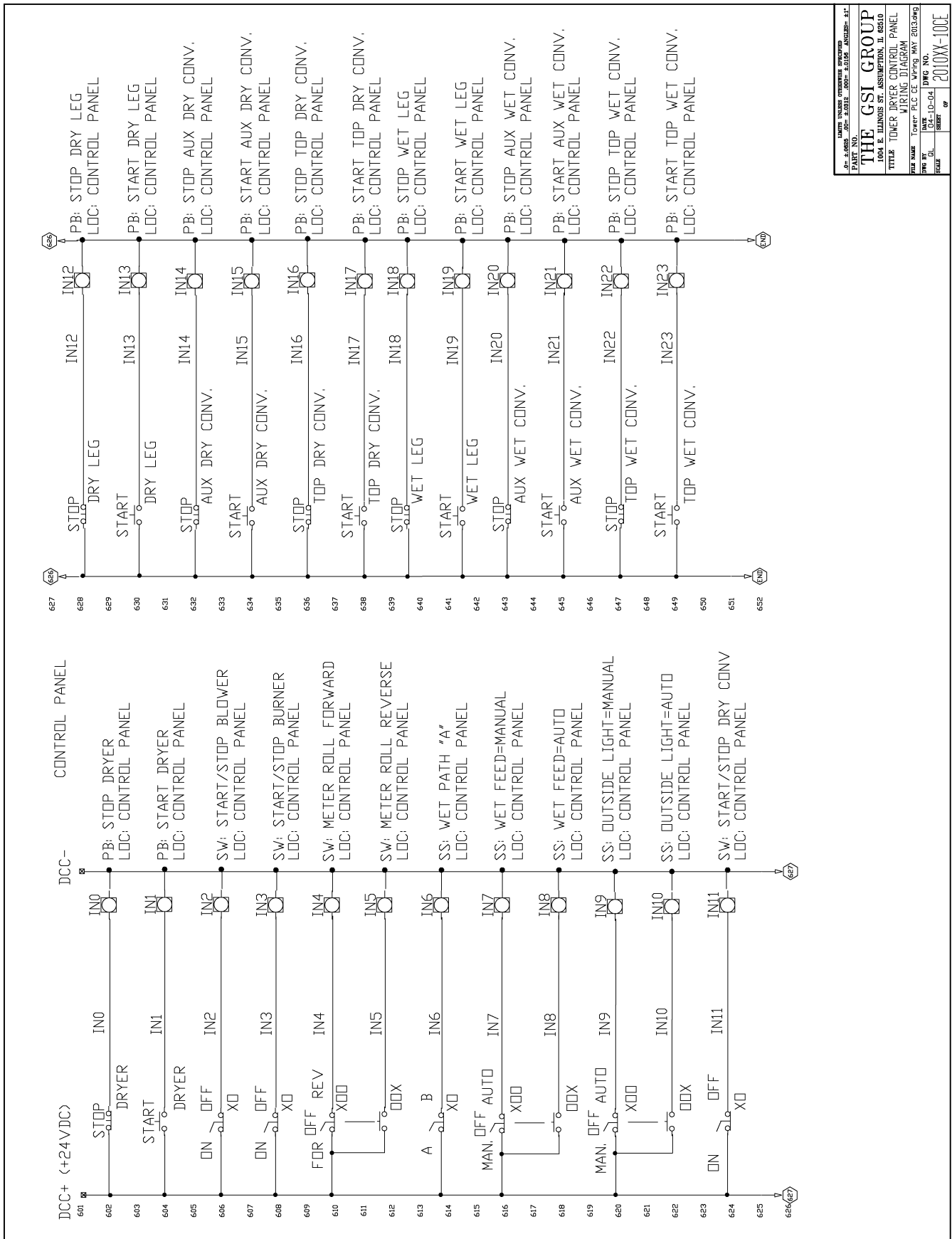

Figure 9Q

9. Tower Dryer Control Panel Wiring Diagrams



THE GSI GROUP	
1004 E. ILLINOIS ST. ASSUMPTION, IL 62510	
TITLE: TOWER DRYER CONTROL PANEL WIRING DIAGRAM	
DATE: 05-04	DRG NO. 2010WX-100E
SCALE:	OF:

Figure 9R

9. Tower Dryer Control Panel Wiring Diagrams

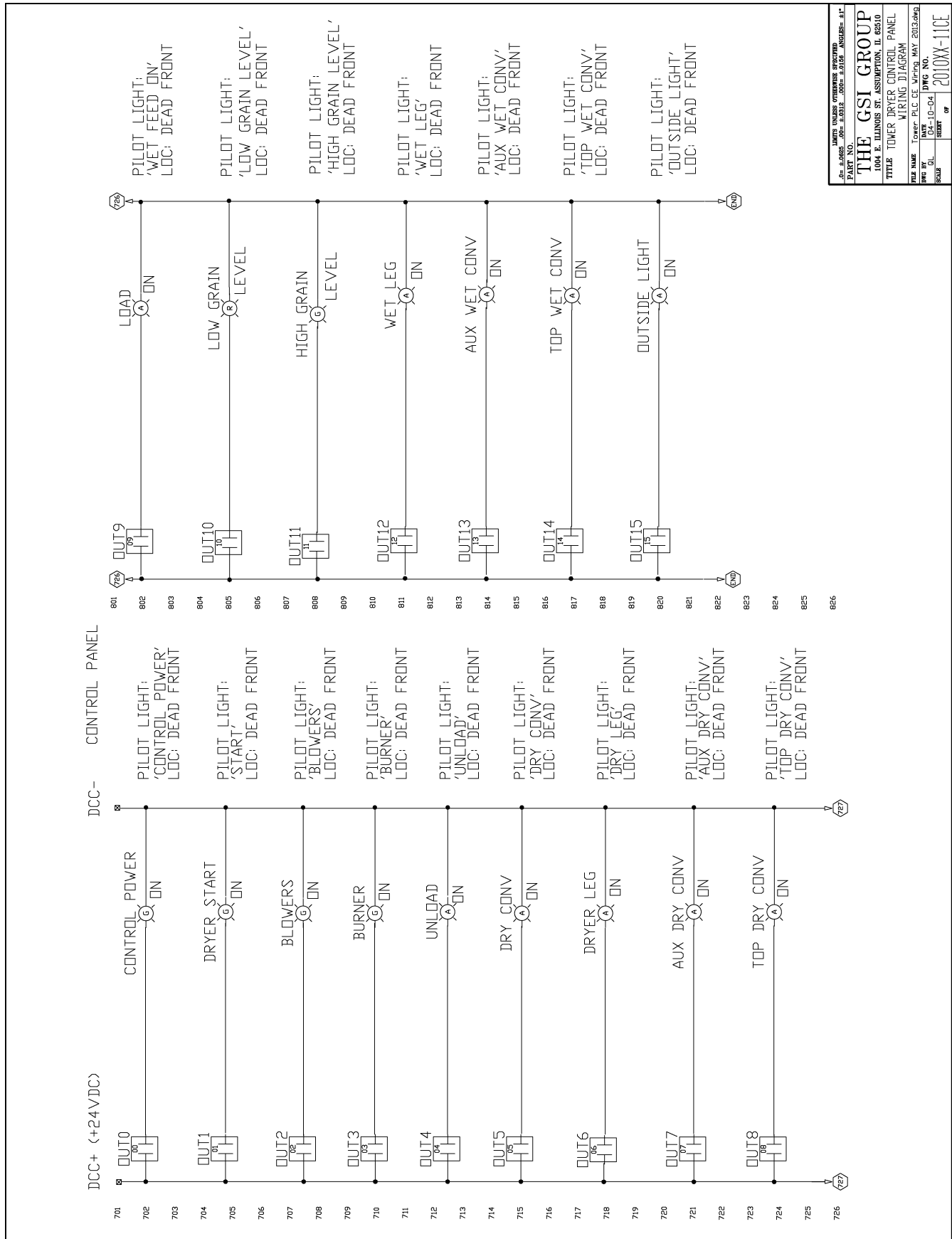

Figure 9S

9. Tower Dryer Control Panel Wiring Diagrams

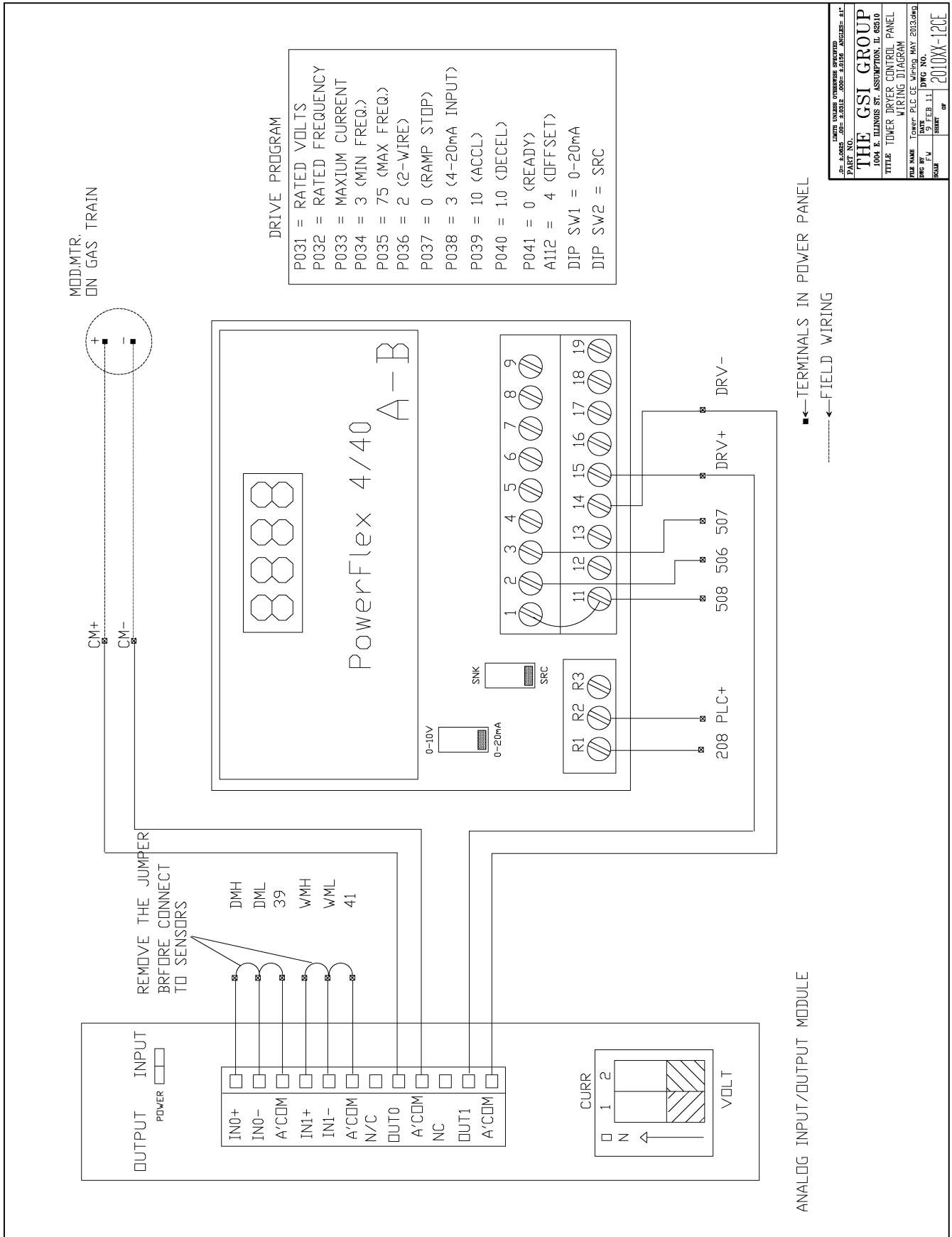

Figure 9T

9. Tower Dryer Control Panel Wiring Diagrams

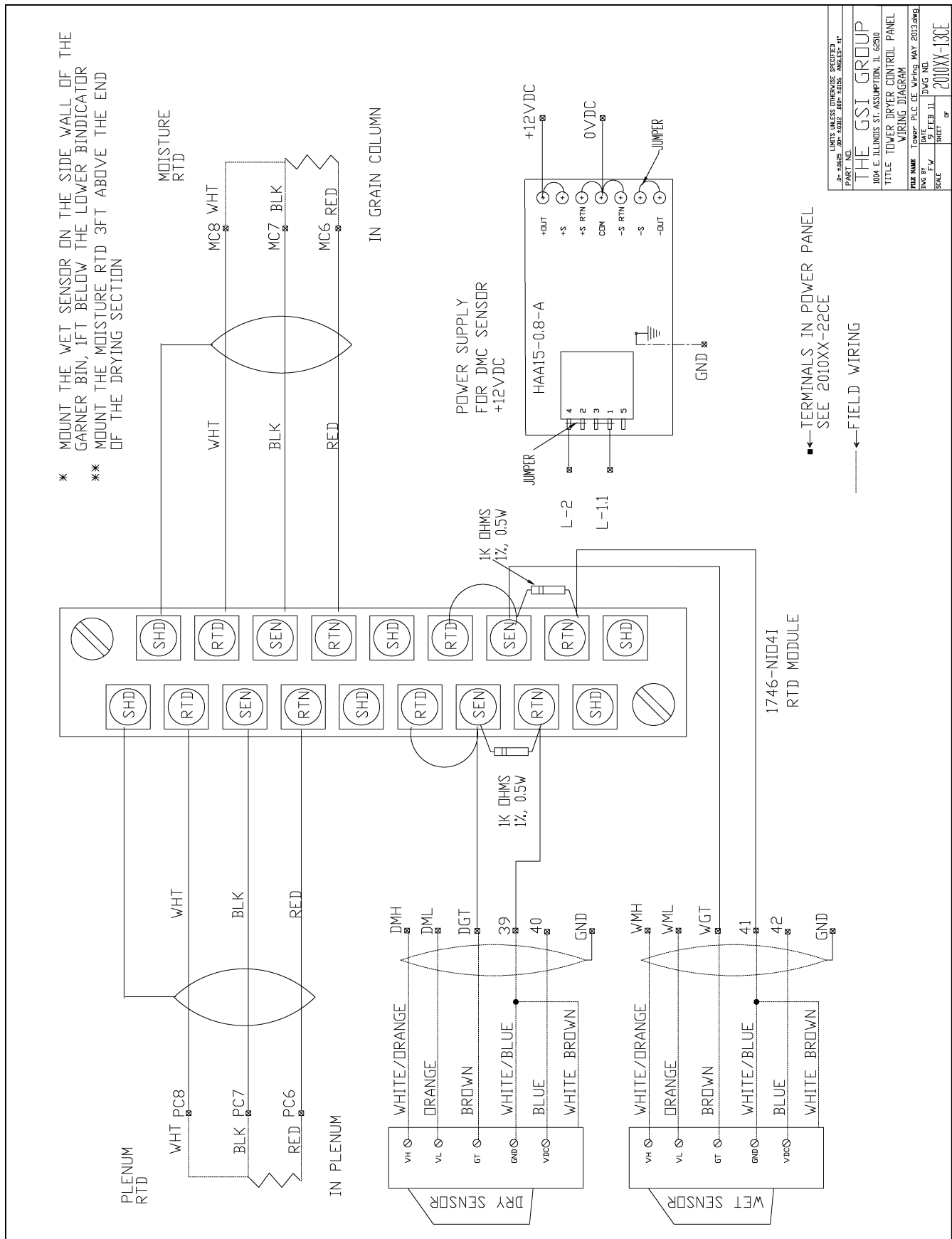
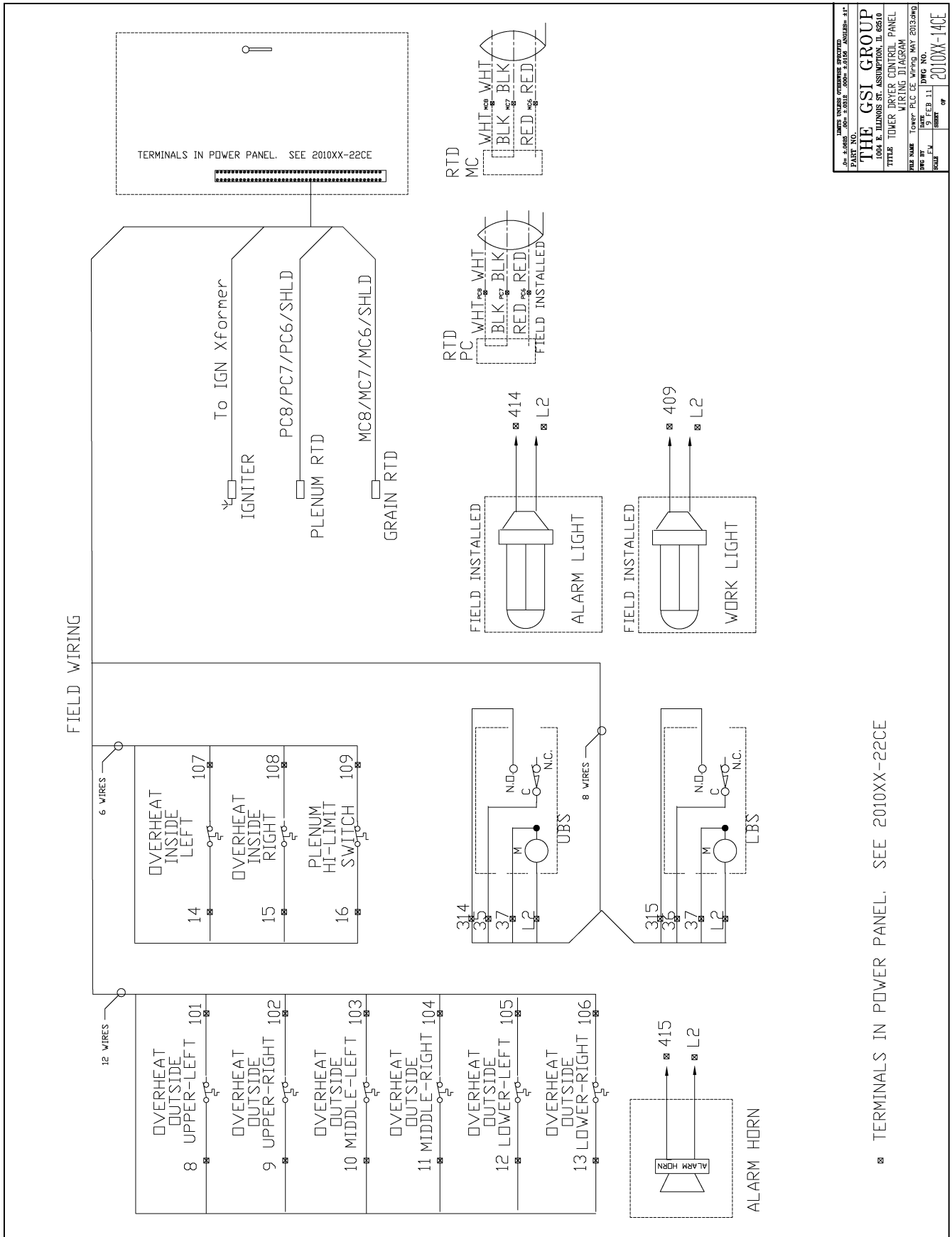

Figure 9U

9. Tower Dryer Control Panel Wiring Diagrams



THE GSI GROUP	
1004 E. ILLINOIS ST., ASSUMPTION, IL 62510	
TITLE: TOWER DRYER CONTROL PANEL WIRING DIAGRAM	
FILE NAME: Tower_PLC_CE_Wiring_May_2013.dwg	DWG NO. 2010XX-14CE
DATE: FEB 11 2013	REVISED BY: [REDACTED]
SCALE: 1"=1'	OR

⊗ TERMINALS IN POWER PANEL. SEE 2010XX-22CE

Figure 9V

9. Tower Dryer Control Panel Wiring Diagrams

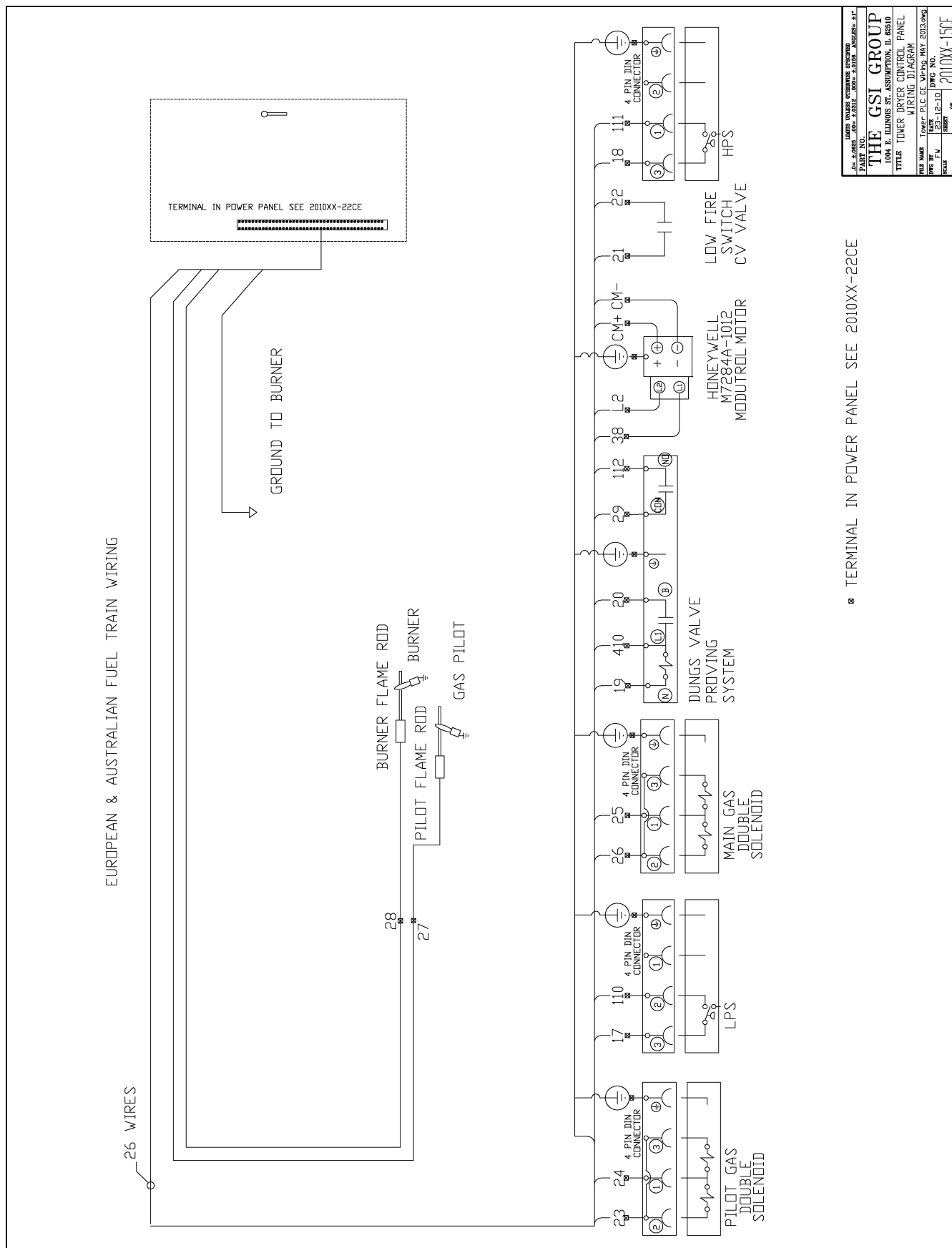

Figure 9W

LIMIT INQUIRY OR ORDERING INFORMATION	
PLC NO. 2010XX-15CE	PLC NO. 2010XX-15CE
THE GSI GROUP	
1004 E. TILDEN ST. ASSUMPTION, IL 62610	
TITLE TOWER DRYER CONTROL PANEL WIRING DIAGRAM	
REV. NAME: Tower-PLC CE Wiring, May 2013/2014	DATE: 12-10-10
SCALE: 1/1	SHEET: OF
2010XX-15CE	

9. Tower Dryer Control Panel Wiring Diagrams

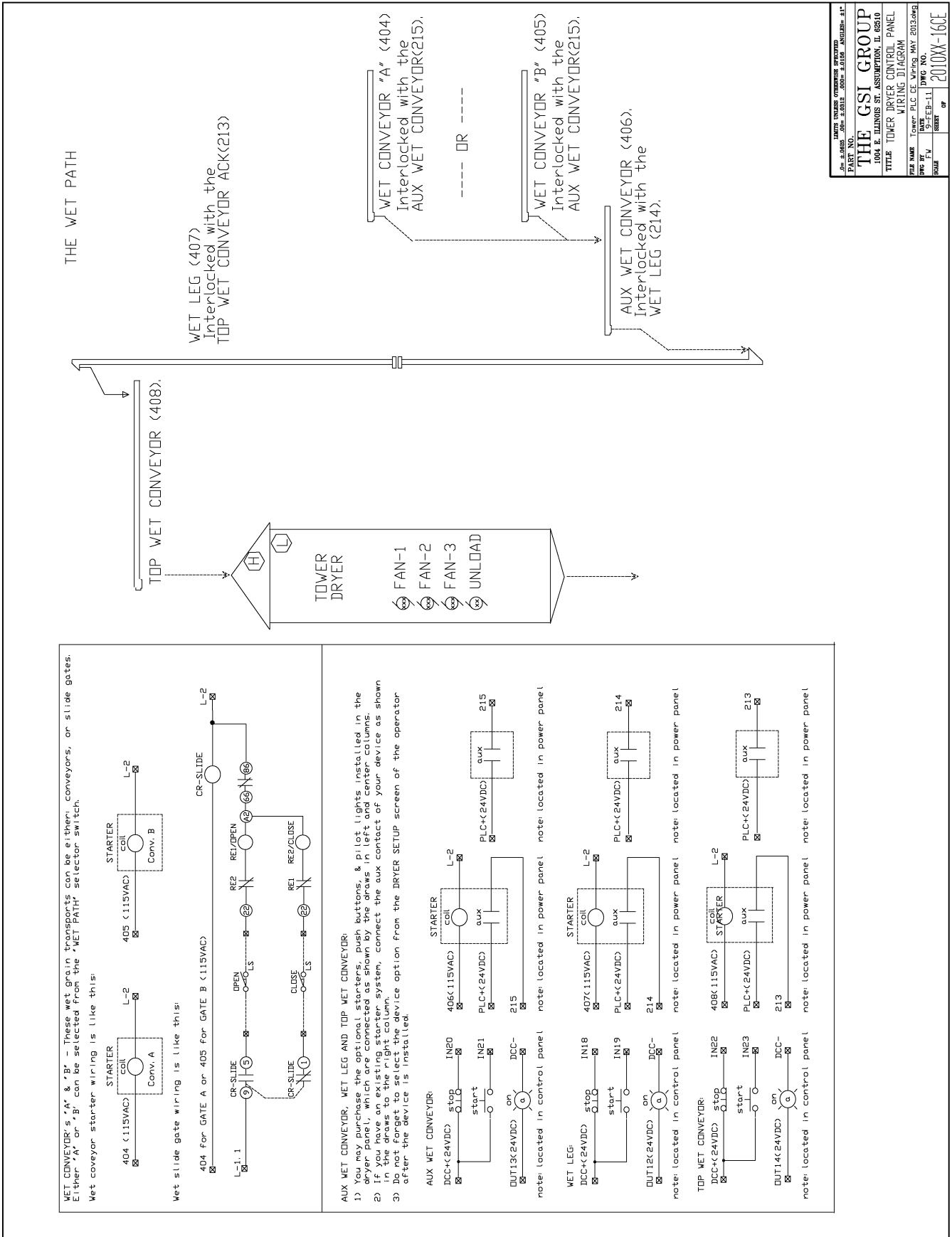

Figure 9X

9. Tower Dryer Control Panel Wiring Diagrams

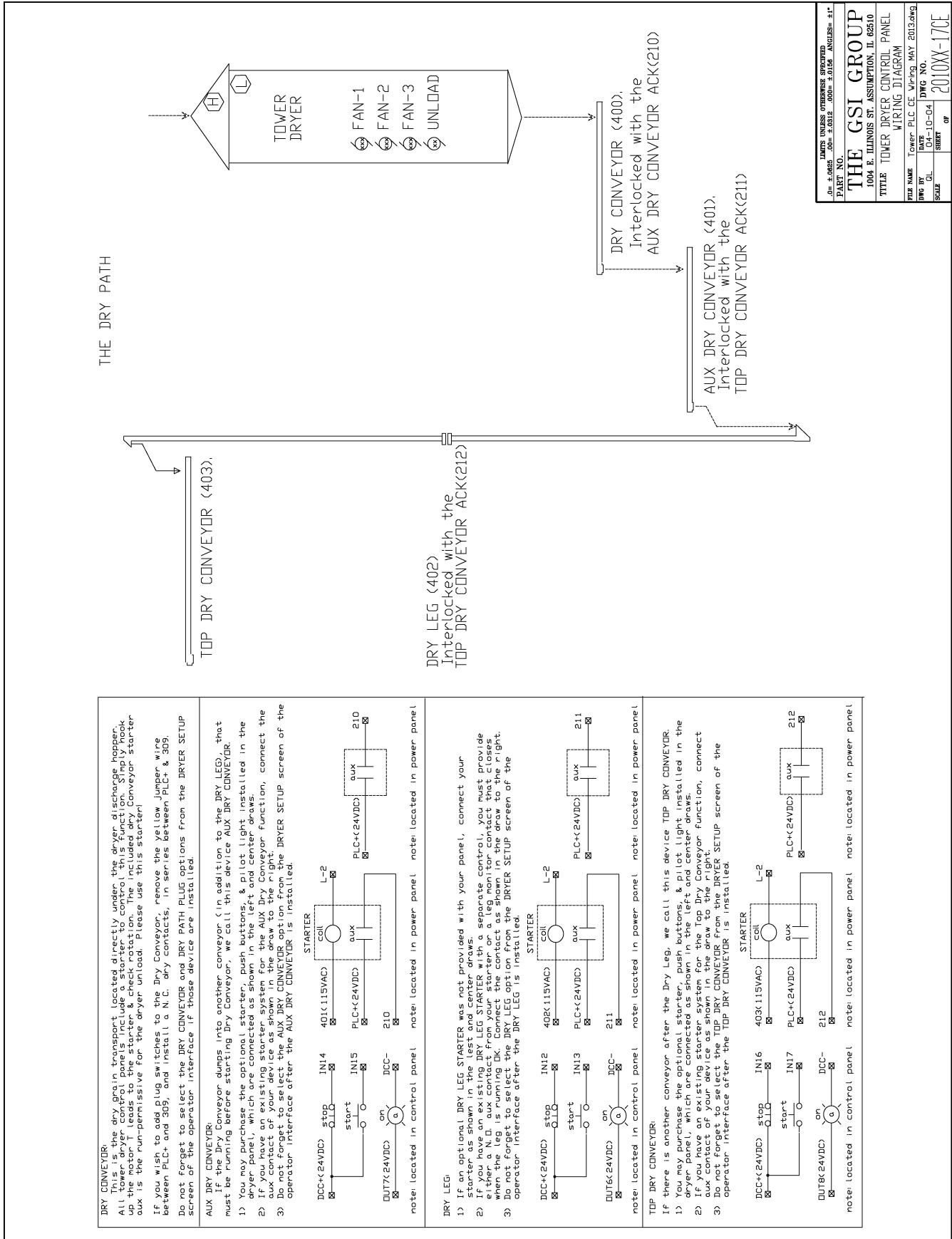

Figure 9Y

9. Tower Dryer Control Panel Wiring Diagrams

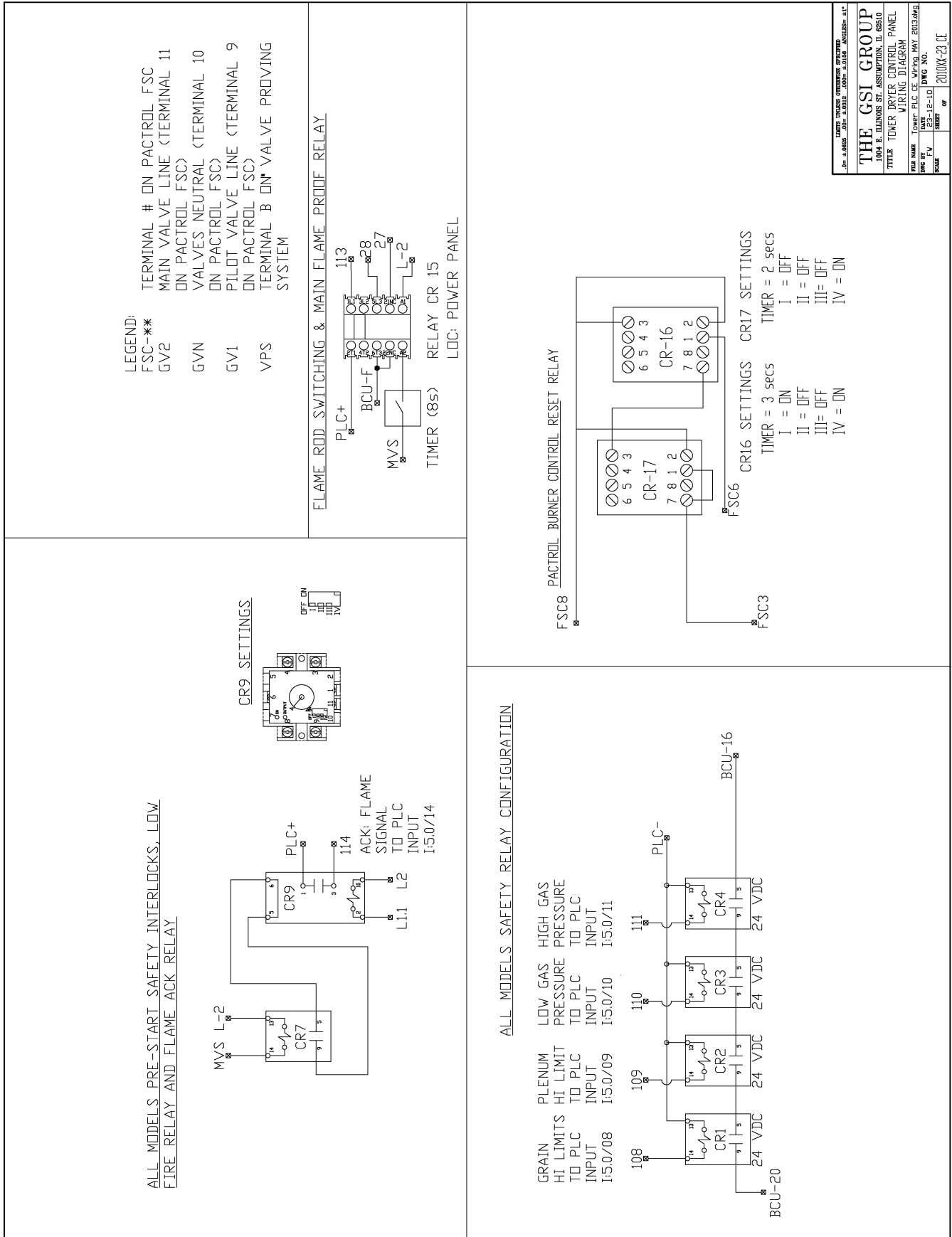
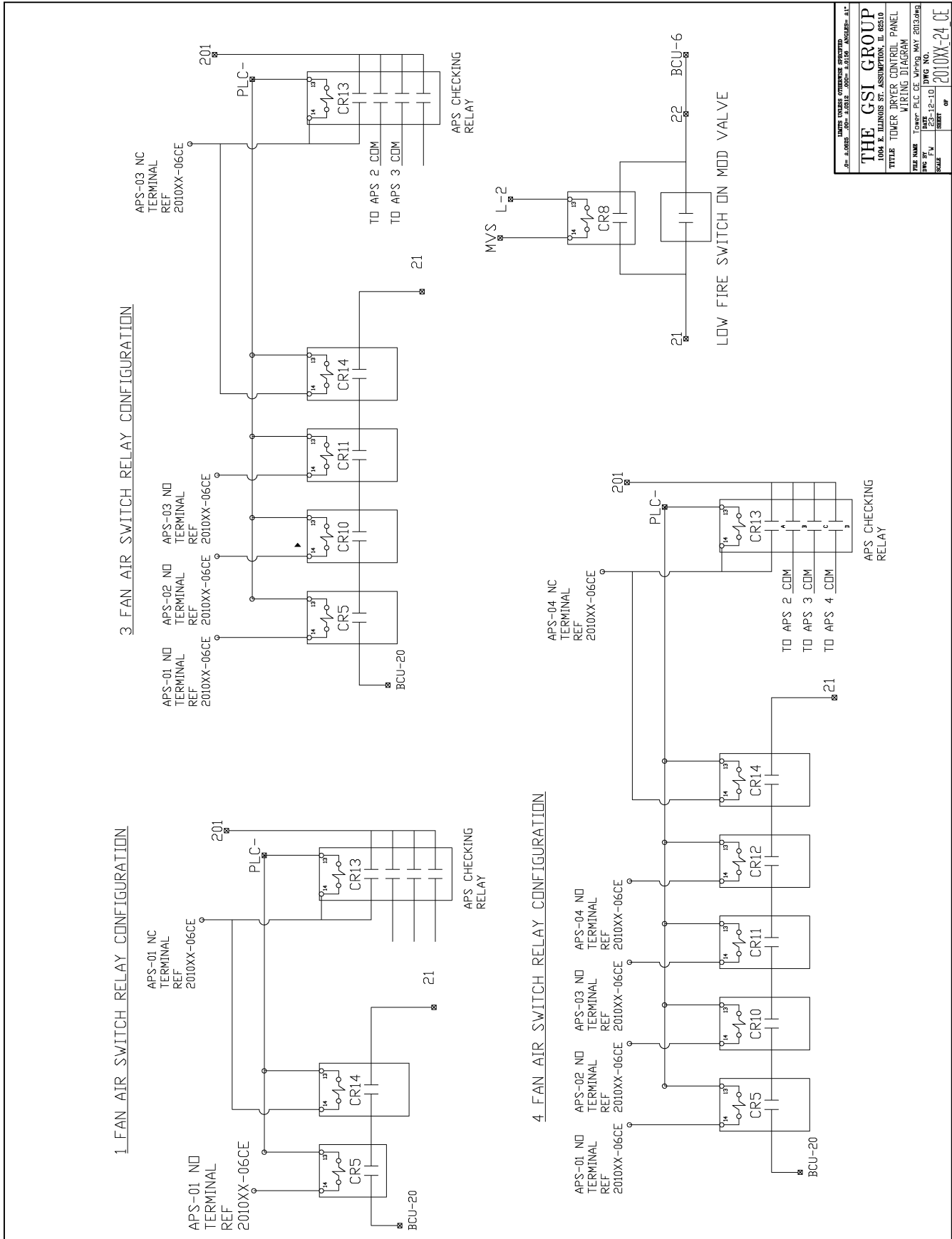

Figure 9Z

9. Tower Dryer Control Panel Wiring Diagrams



LIMITS UNDER OPERATING CONDITIONS	
AP-1000	AP-1000
AP-1000	AP-1000
THE GSI GROUP	
1004 N. HAZARD ST. ASSUMPTION, IL 62510	
TITLE TOWER DRYER CONTROL PANEL	
WIRING DIAGRAM	
DATE	DATE
BY	BY
REV	REV
SCALE	SCALE
2010XX-24-CE	2010XX-24-CE

Figure 9AA

9. Tower Dryer Control Panel Wiring Diagrams

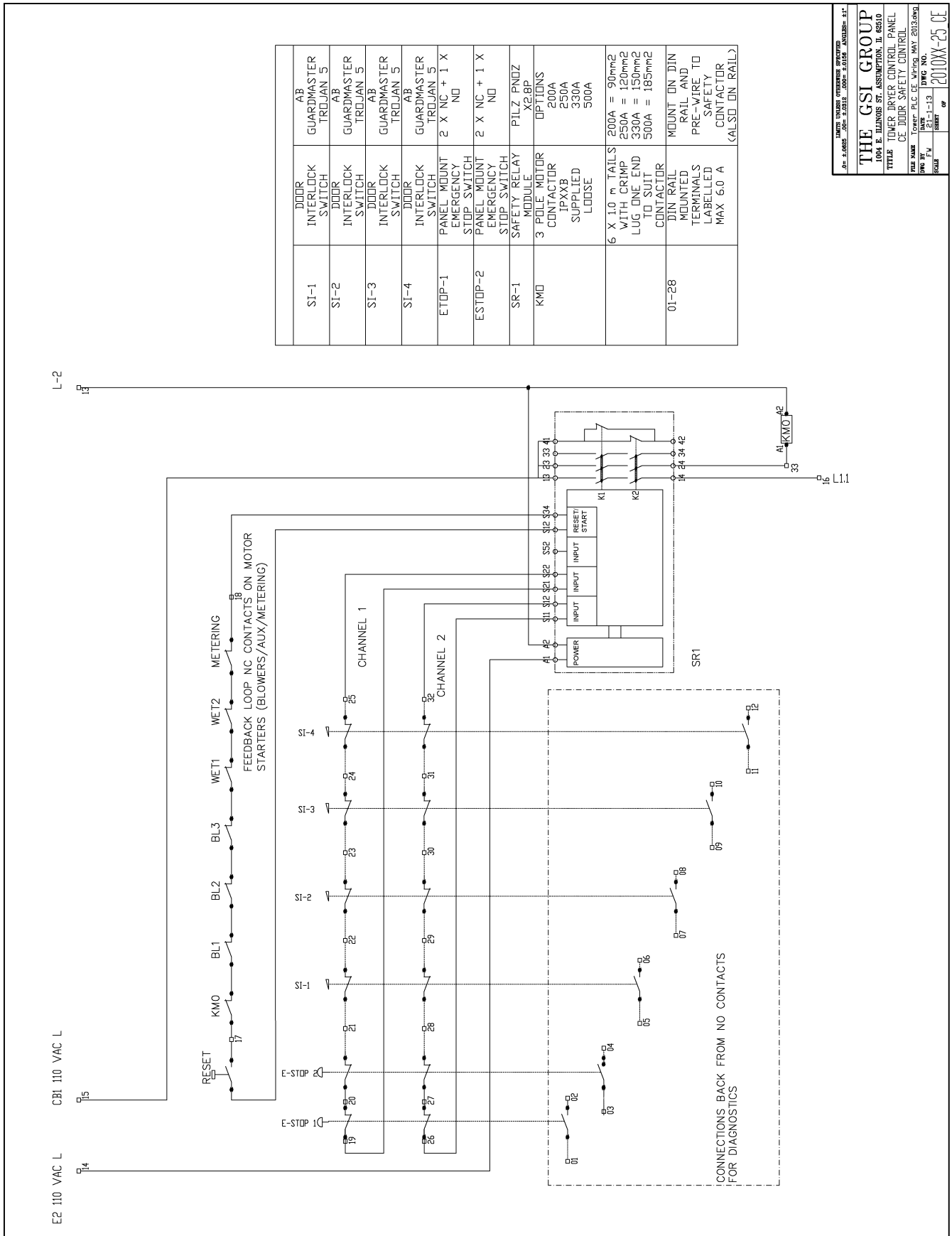

Figure 9AB

9. Tower Dryer Control Panel Wiring Diagrams

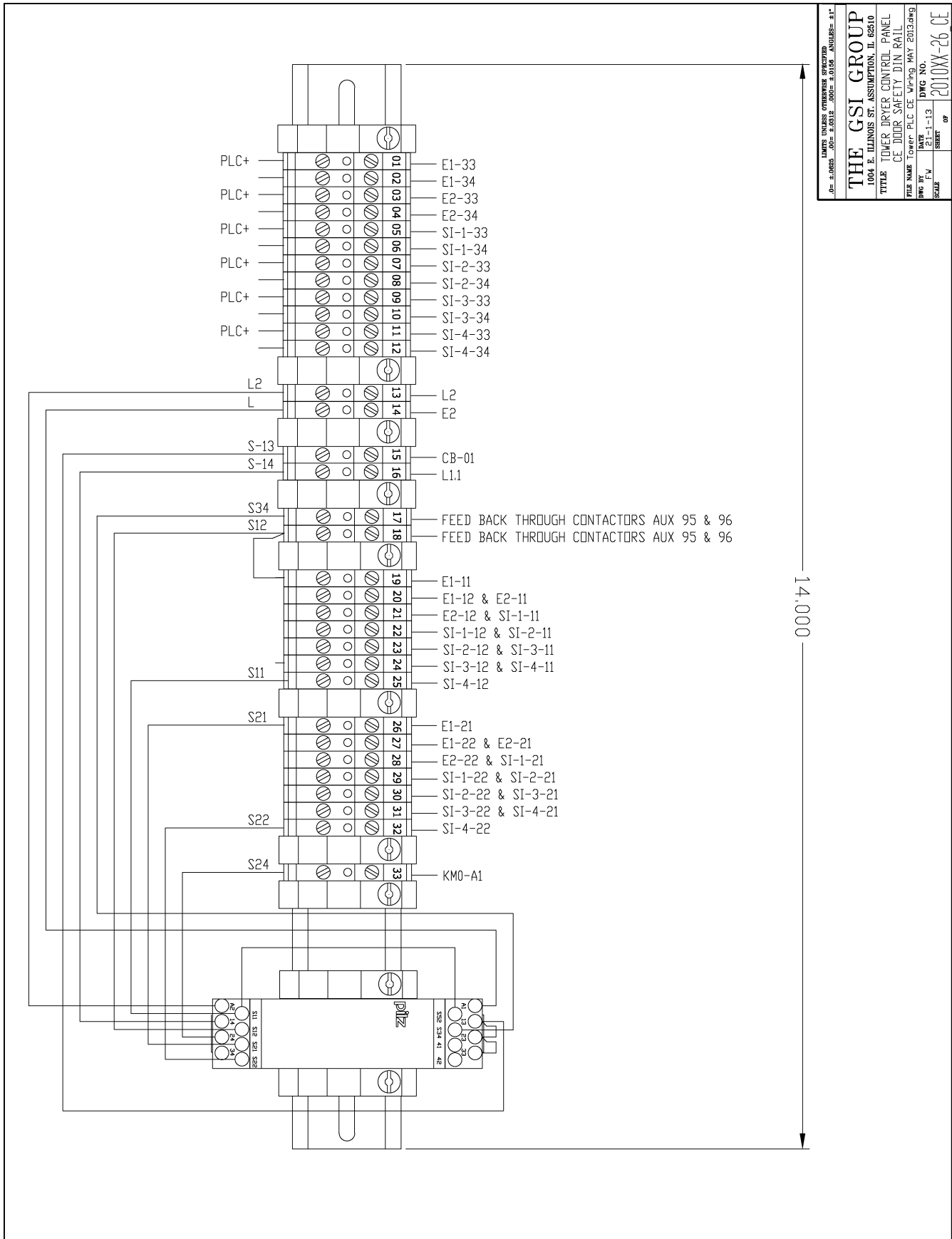

Figure 9AC

9. Tower Dryer Control Panel Wiring Diagrams

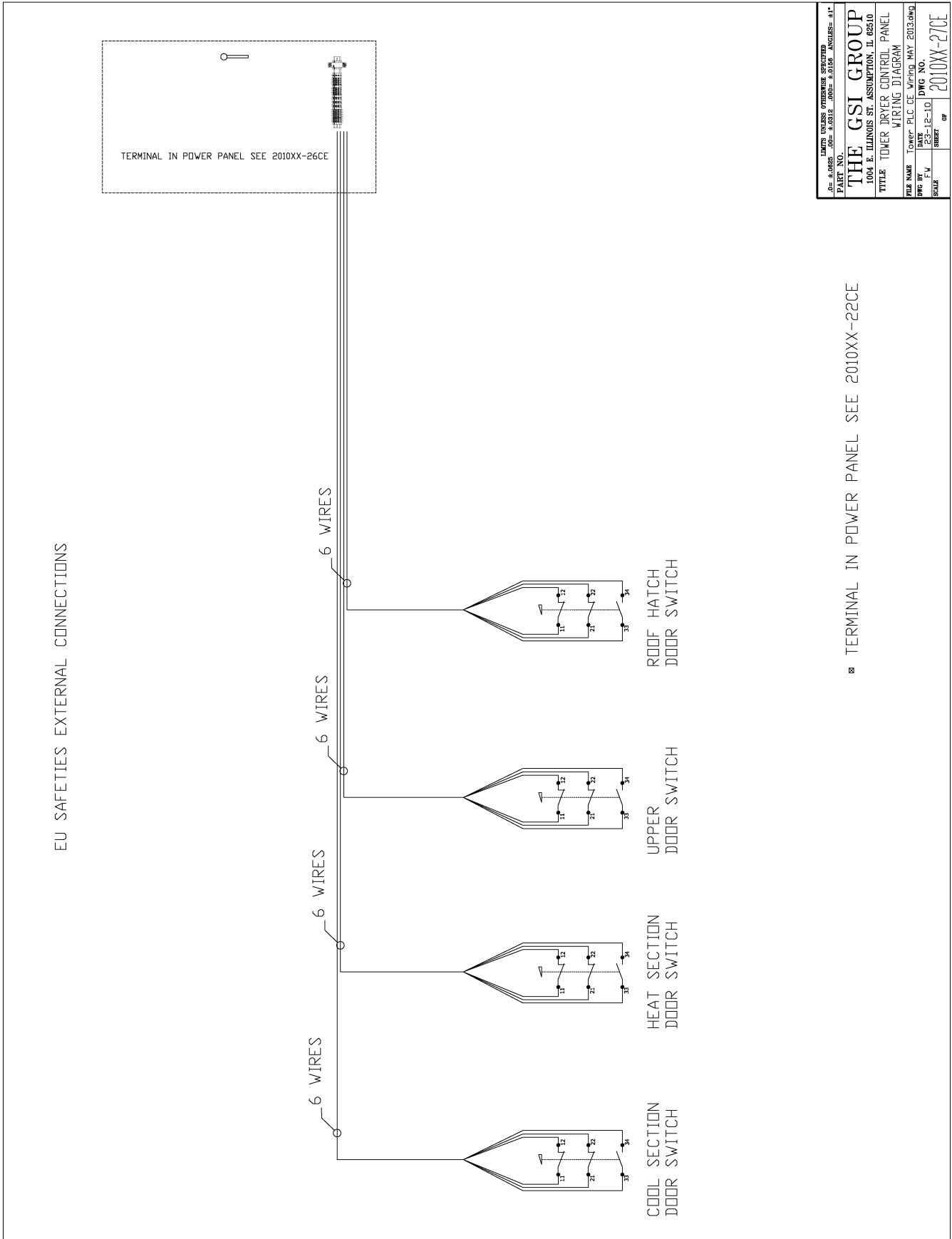

Figure 9AD

NOTES

GSI Group, LLC Limited Warranty

The GSI Group, LLC ("GSI") warrants products which it manufactures to be free of defects in materials and workmanship under normal usage and conditions for a period of 12 months after sale to the original end-user or if a foreign sale, 14 months from arrival at port of discharge, whichever is earlier. The end-user's sole remedy (and GSI's only obligation) is to repair or replace, at GSI's option and expense, products that in GSI's judgment, contain a material defect in materials or workmanship. Expenses incurred by or on behalf of the end-user without prior written authorization from the GSI Warranty Group shall be the sole responsibility of the end-user.

Warranty Extensions:

The Limited Warranty period is extended for the following products:

	Product	Warranty Period	
AP Fans and Flooring	Performer Series Direct Drive Fan Motor	3 Years	* Warranty prorated from list price: 0 to 3 years - no cost to end-user 3 to 5 years - end-user pays 25% 5 to 7 years - end-user pays 50% 7 to 10 years - end-user pays 75%
	All Fiberglass Housings	Lifetime	
	All Fiberglass Propellers	Lifetime	
AP and Cumberland	Flex-Flo/Pan Feeding System Motors	2 Years	** Warranty prorated from list price: 0 to 3 years - no cost to end-user 3 to 5 years - end-user pays 50%
Cumberland Feeding/Watering Systems	Feeder System Pan Assemblies	5 Years **	
	Feed Tubes (1-3/4" and 2.00")	10 Years *	
	Centerless Augers	10 Years *	
	Watering Nipples	10 Years *	
Grain Systems	Grain Bin Structural Design	5 Years	† Motors, burner components and moving parts not included. Portable dryer screens included. Tower dryer screens not included.
Grain Systems Farm Fans Zimmerman	Portable and Tower Dryers	2 Years	
	Portable and Tower Dryer Frames and Internal Infrastructure †	5 Years	

GSI further warrants that the portable and tower dryer frame and basket, excluding all auger and auger drive components, shall be free from defects in materials for a period of time beginning on the twelfth (12th) month from the date of purchase and continuing until the sixtieth (60th) month from the date of purchase (extended warranty period). During the extended warranty period, GSI will replace the frame or basket components that prove to be defective under normal conditions of use without charge, excluding the labor, transportation, and/or shipping costs incurred in the performance of this extended warranty.

Conditions and Limitations:

THERE ARE NO WARRANTIES THAT EXTEND BEYOND THE LIMITED WARRANTY DESCRIPTION SET FORTH ABOVE. SPECIFICALLY, GSI MAKES NO FURTHER WARRANTY OF ANY KIND, EXPRESS OR IMPLIED, INCLUDING, WITHOUT LIMITATION, WARRANTIES OF MERCHANTABILITY OR FITNESS FOR A PARTICULAR PURPOSE OR USE IN CONNECTION WITH: (I) PRODUCT MANUFACTURED OR SOLD BY GSI OR (II) ANY ADVICE, INSTRUCTION, RECOMMENDATION OR SUGGESTION PROVIDED BY AN AGENT, REPRESENTATIVE OR EMPLOYEE OF GSI REGARDING OR RELATED TO THE CONFIGURATION, INSTALLATION, LAYOUT, SUITABILITY FOR A PARTICULAR PURPOSE, OR DESIGN OF SUCH PRODUCTS.

GSI shall not be liable for any direct, indirect, incidental or consequential damages, including, without limitation, loss of anticipated profits or benefits. The sole and exclusive remedy is set forth in the Limited Warranty, which shall not exceed the amount paid for the product purchased. This warranty is not transferable and applies only to the original end-user. GSI shall have no obligation or responsibility for any representations or warranties made by or on behalf of any dealer, agent or distributor.

GSI assumes no responsibility for claims resulting from construction defects or unauthorized modifications to products which it manufactured. Modifications to products not specifically delineated in the manual accompanying the equipment at initial sale will void the Limited Warranty.

This Limited Warranty shall not extend to products or parts which have been damaged by negligent use, misuse, alteration, accident or which have been improperly/inadequately maintained. This Limited Warranty extends solely to products manufactured by GSI.

Prior to installation, the end-user has the responsibility to comply with federal, state and local codes which apply to the location and installation of products manufactured or sold by GSI.

This equipment shall be installed in accordance with the current installation codes and applicable regulations, which should be carefully followed in all cases. Authorities having jurisdiction should be consulted before installations are made.



**1004 E. Illinois St.
Assumption, IL 62510-0020
Phone: 1-217-226-4421
Fax: 1-217-226-4420
www.gsiag.com**



GSI is a worldwide brand of AGCO Corporation.