



Tower Dryer Construction Manual



a division of

THE GSI GROUP



18'

PNEG 707

Printed: March 1999

Introduction

Thank you for choosing a Grain Systems tower grain dryer. This manual describes how to assemble tower dryers, all models. This dryer is one of the finest grain conditioning products ever built. It is designed to give excellent performance and service for many years.

GSI Mission

"Provide our customers with awesome service and products in order to grow our company to be the world leader, using a best cost producer strategy, with empowered associates who enjoy their jobs."



Welcome to The GSI Group, Inc. in Assumption, Illinois.



- This product is intended for grain conditioning only. Any other application is a misuse of product. Misuse of product may cause injury. Misuse of product may void warranty.
- This product has sharp edges. These sharp edges may cause serious injury. To avoid injury use proper protective clothing and equipment at all times.
- It is important to read and understand this manual. Know and use safe operating procedures. Know and prevent safety hazards.
- It is the responsibility of the dryer owner and/or the dryer operator to read this manual and to know the equipment requirements and safety hazards. Inform all personnel who work with the equipment, or who are in the dryer area, about safety hazards to prevent injury or damage.



A careful operator reduces risk of personal injury and equipment damage.

Electrical Power Supply: Grain Systems recommends you contact your local power company and request that a representative inspect your dryer installation. Be sure your wiring is compatible with your power company's system and that you will have adequate power supplied to dryer.

Material Safety Data Sheets (MSDS): MSDS are available upon request.

Safety Icon:



This icon indicates safety and hazards to people and equipment. This icon is used to call your attention to instructions for your personal safety and/or safety of the equipment. Watch for this symbol. Use safety precautions to prevent injury to people and damage to equipment.

Safety Words:*

“DANGER” (red) this word means the hazard or unsafe practice **will** result in **severe** injury or **death**.

“WARNING” (orange) this word means the hazard or unsafe practice **could** result in **severe** injury or **death**.

“CAUTION” (yellow) this word means the hazard or unsafe practice **could** result in **minor** injury or **property damage**.

* These safety words conform to the American National Standards Institute draft standard ANSI Z535.4, “American National Standards for Product Safety Signs and Labels,” 1989.

Safety Decals :

Some of the required safety decals are placed on the dryer before shipping. The remainder are placed on the dryer during electrical installations. The purpose of the safety decals is to immediately alert all personnel to the hazards of an operating dryer. The safety decal does not replace the need for all personnel to know and understand safe dryer operations and requirements. Read the “Dryer Operations and Service Manual”.



Safety decals should be read and understood by all people in or around the dryer area.

The following pages of “SAFETY DECALS ” identify and give the location of all safety decals that should be on each tower dryer. Safety decals are listed in numerical order.



If the safety decals on the following pages are not on your dryer, or if they are damaged, immediately contact Grain Systems for replacement safety decals.

U.S. telephone: 217.226.4421
U.S. toll free fax: 1.800.800.5329
International fax: 217.226.3404
e-mail: gsisales@grainsystems.com
internet: <http://www.grainsystems.com>



1004 East Illinois Street
Post Office Box 20
Assumption, IL 62510-0020
United States of America



Safety Decal # DC-552

Location of Decals (1) (English and Spanish) decals are placed on inside of tower roof access port before shipping.

Safety Decal



Tower roof access port with decals in place.



Inside View - access port installed with decals in place.



Outside View - access port installed with decals in place.

Safety Decal # DC-889

- Location of Decal**
- (1) on outside of main power box, on right door.
 - (2) on outside of main power box, on left door.
 - (3) inside main power box door, on same side as main electrical disconnect.

Safety Decal

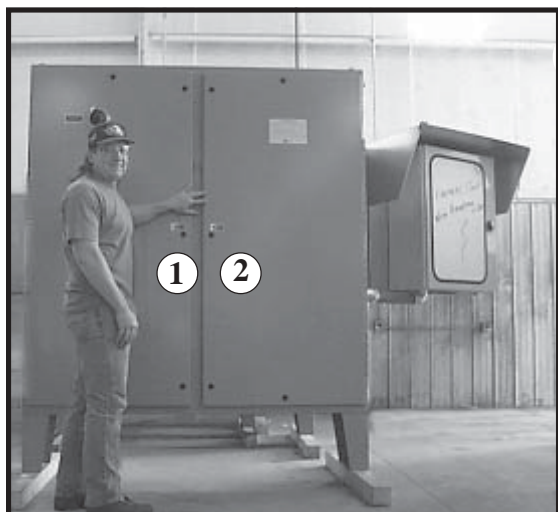
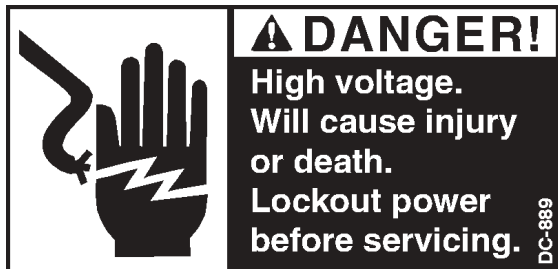

Example - Electrical Control System.

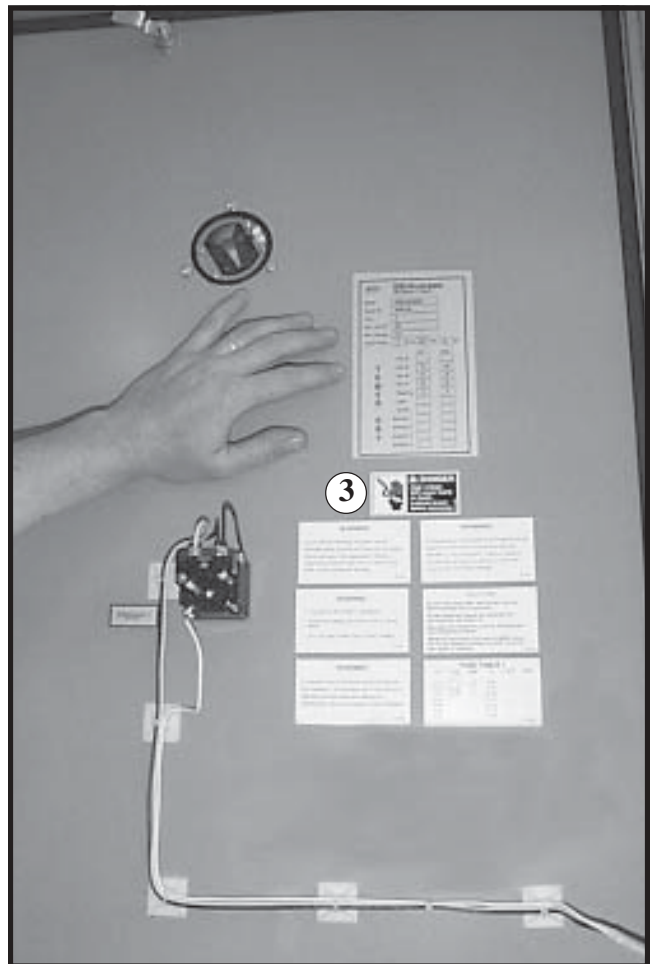



Safety Decal # DC-985

Location of Decal (1) inside main power box door,
on same side as main electrical disconnect.

Safety Decal

FUSE TABLE 1					
F#	TYPE	AMP	F#	TYPE	AMP
FU1	_____	_____	FU8	_____	_____
FU2	_____	_____	FU9	_____	_____
FU3	_____	_____	FU10	_____	_____
FU4	_____	_____	FU11	_____	_____
FU5	_____	_____	FU12	_____	_____
FU6	_____	_____	FU13	_____	_____
FU7	_____	_____	FU14	_____	_____

DC-985

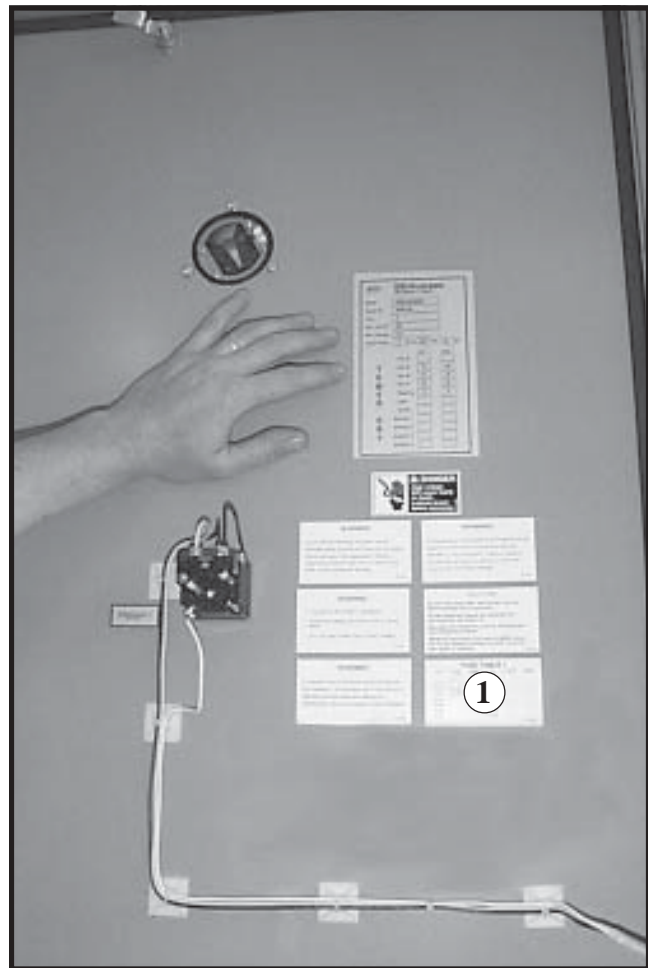

Safety Decal # DC-987

Location of Decal (1) inside main power box door,
on same side as main electrical disconnect.

Safety Decal

<p style="text-align: center;">WARNING</p> <p>Line side of disconnect is energized.</p> <p>Hazardous voltage can shock, burn or cause death.</p> <p>This unit may contain one or more voltages.</p> <p style="text-align: right;">DC-987</p>





Safety Decal # DC-988

Location of Decal (1) inside main power box door,
on same side as main electrical disconnect.

Safety Decal

WARNING

To maintain overcurrent short circuit and ground fault protection, the manufacturer's instructions for selecting overload relays and setting the instantaneous trip circuit breaker must be followed.

DC-988

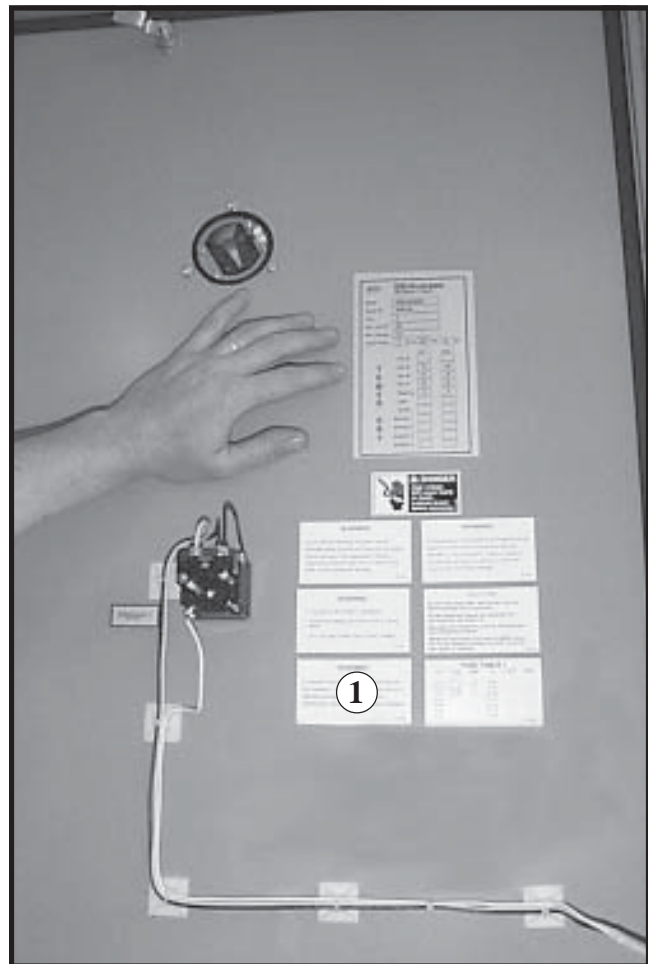

Safety Decal # DC-989

Location of Decal (1) inside main power box door,
on same side as main electrical disconnect.

Safety Decal**WARNING**

Insure that the incoming AC power and all separate power sources are turned off and locked before working on this equipment. Failure to observe this practice may result in severe injury, death, and/or equipment damage.

DC-989

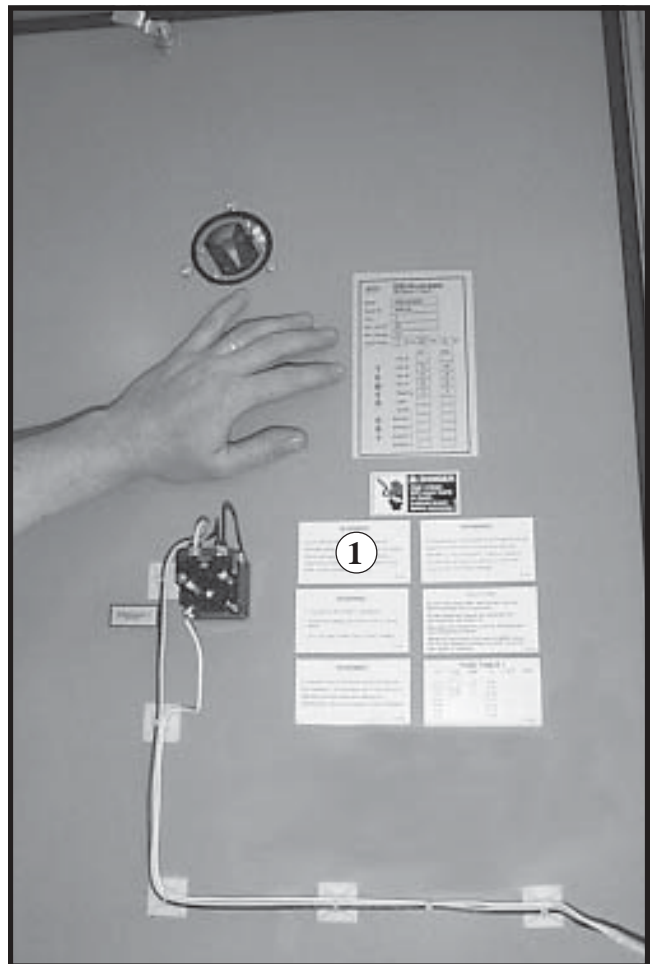



Safety Decal # DC-990

Location of Decal (1) inside main power box door,
on same side as main electrical disconnect.

Safety Decal

WARNING

All maintenance procedures must be performed by qualified personnel who are familiar with the operation of this equipment. Failure to observe this warning can result in serious or even fatal injury and/or equipment damage.

DC-990

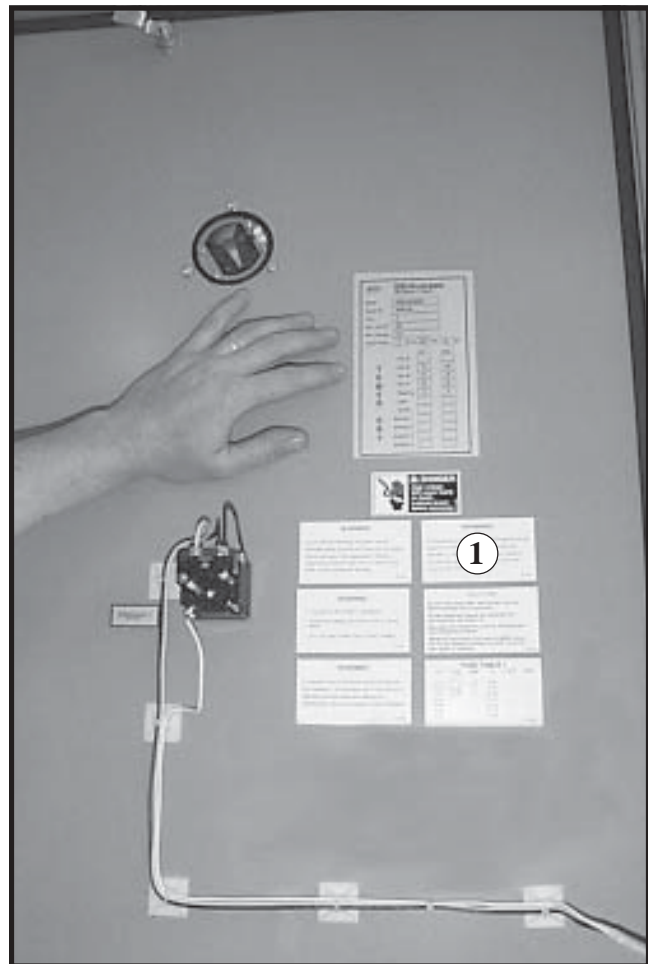

Safety Decal # DC-991

Location of Decal (1) inside main power box door,
on same side as main electrical disconnect.

Safety Decal

Be sure that charge light and all LED's are out before touching any components.

All test equipment should be connected and disconnected with power off.

Grounded test equipment, such as oscilloscopes, may damage the inverter.

Isolate all instruments from ground before using. The DC bus remains charged for several minutes after power is removed.

DC-991

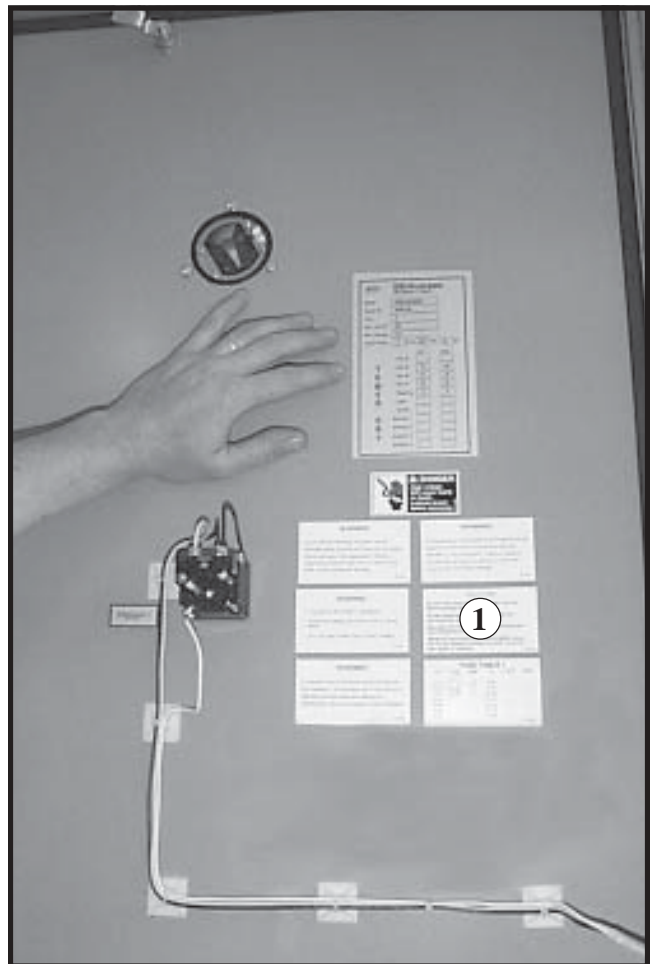



Safety Decal # DC-1060

Location of Decal (1) on outside of hopper service door.
(2) on outside of hopper service door.

Safety Decal

! DANGER!

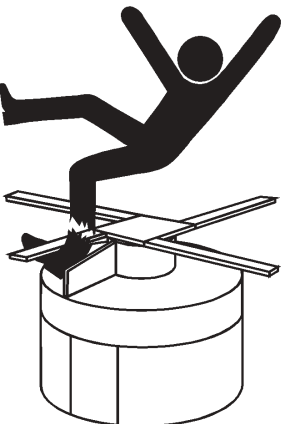

Rotating drum below.
Will cause serious injury
or death. Lockout power
before entering
or servicing.

DC-1060

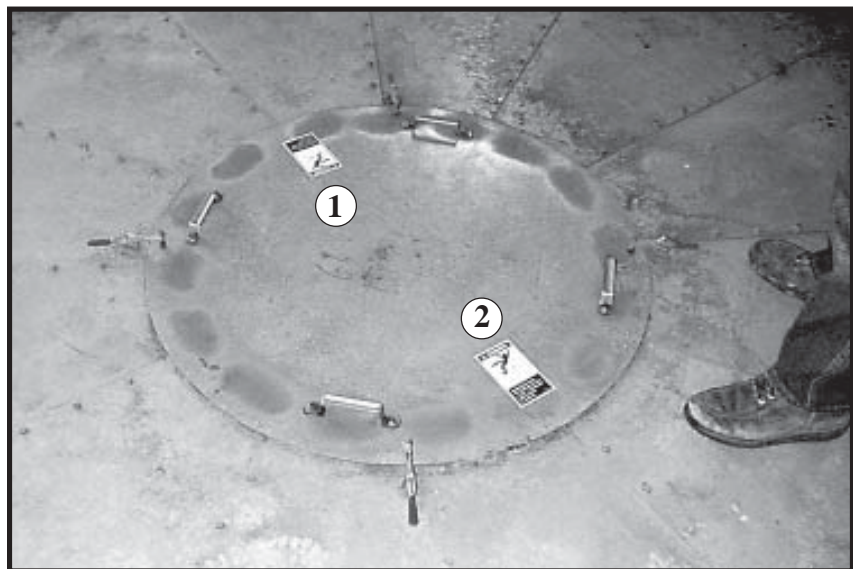

Safety Decal # DC-1061

Location of Decal (1) on outside of heat section door.

Safety Decal

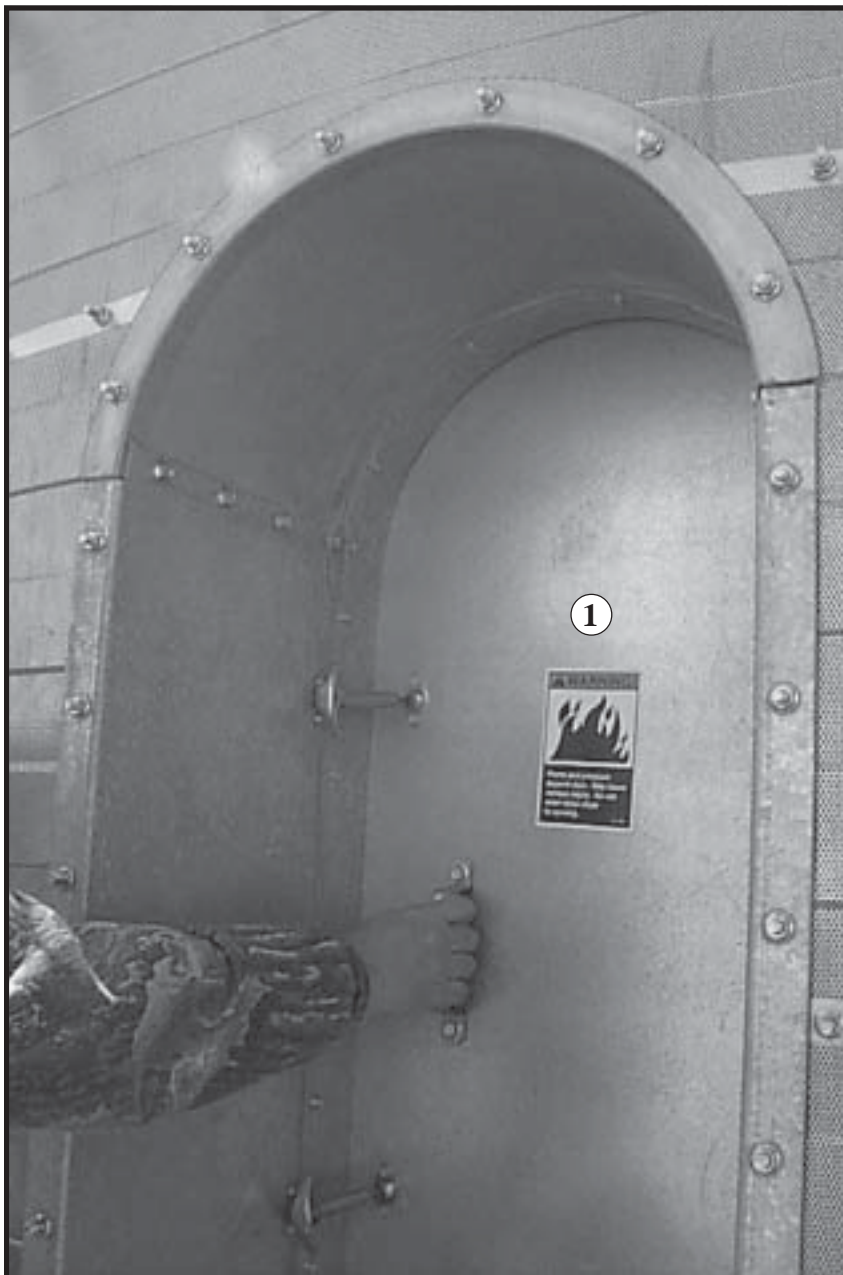



Safety Decal # DC-1062

- Location of Decal**
- (1) on upper ring around hopper access door opening.
 - (2) on upper ring around hopper access door opening.

Safety Decal



Close-up of safety decal #DC-1062.

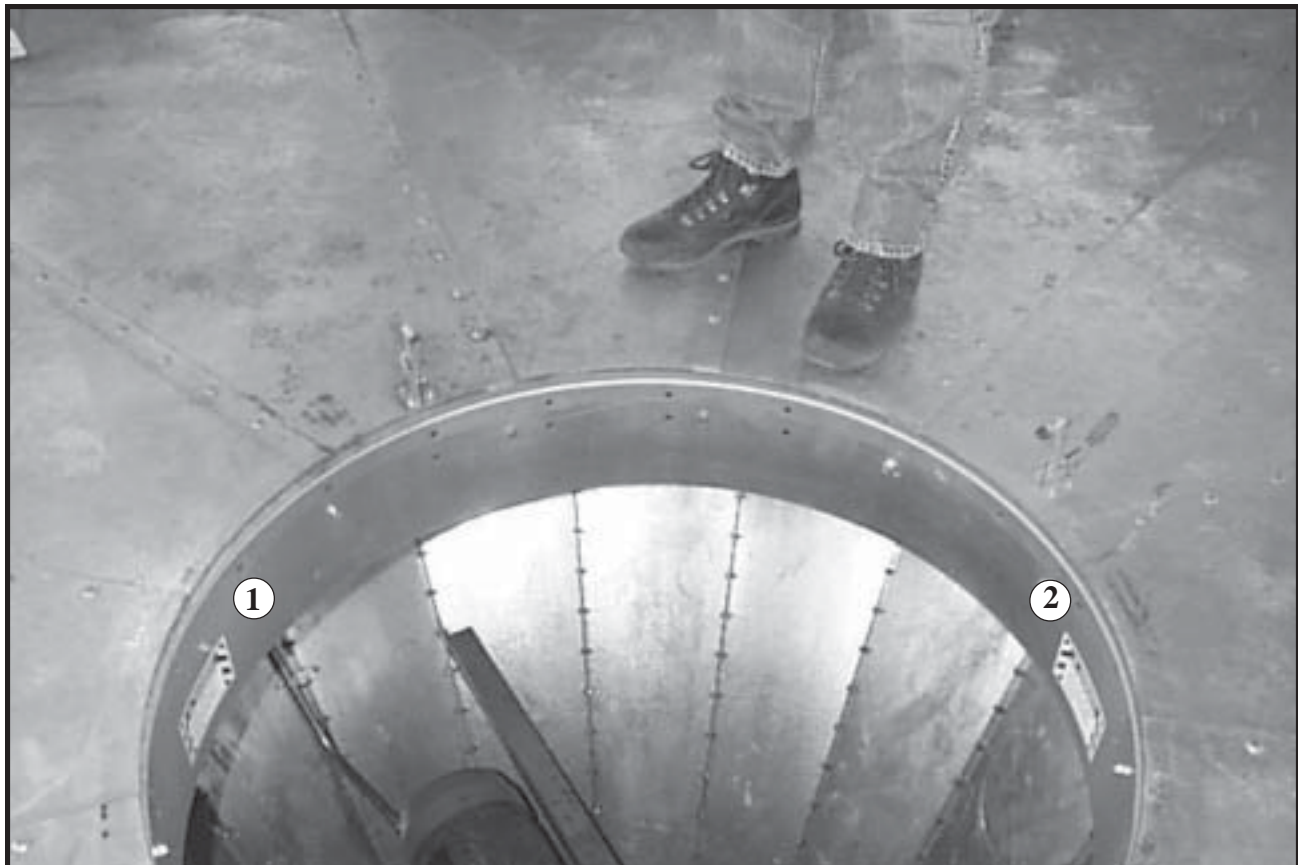

Safety Decal # DC-1063

Location of Decal (1) on outside of cool section door.

Safety Decal

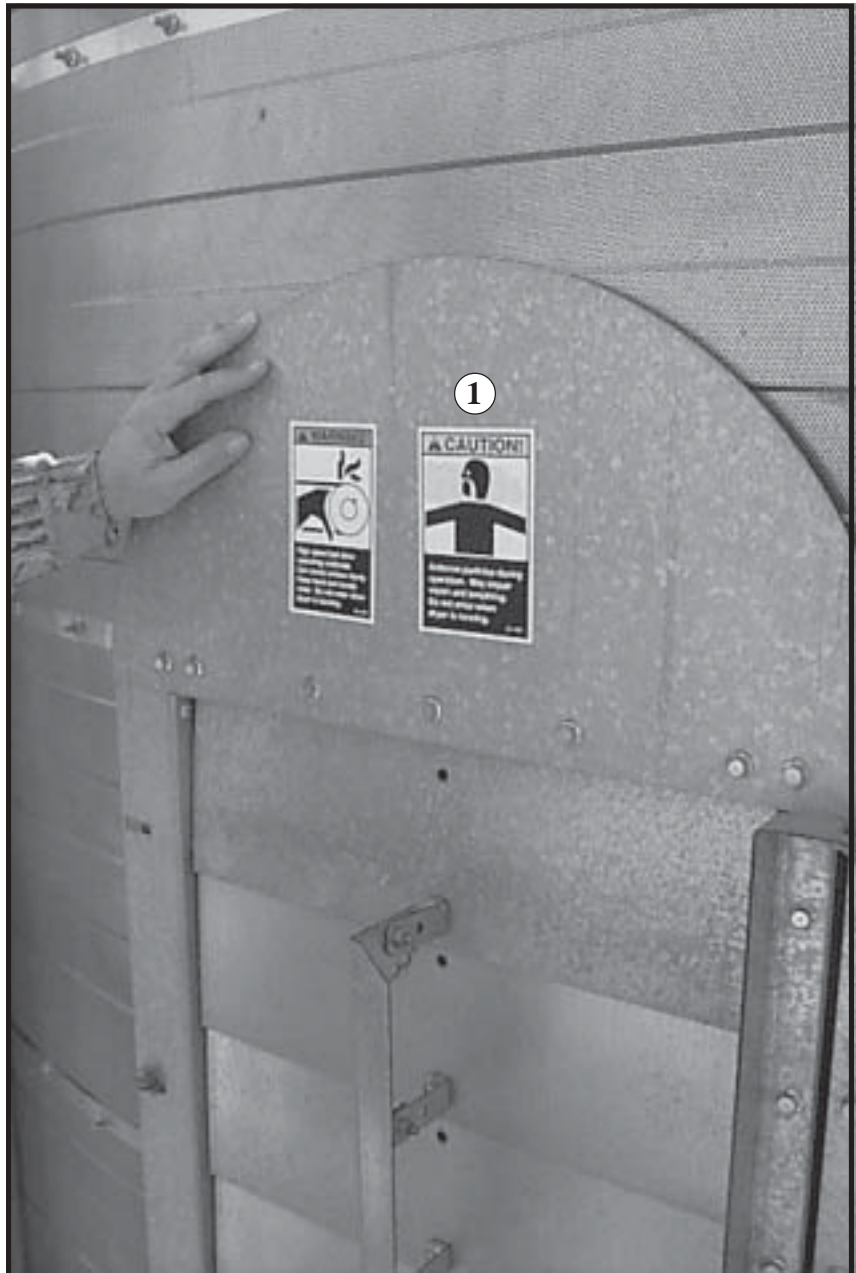
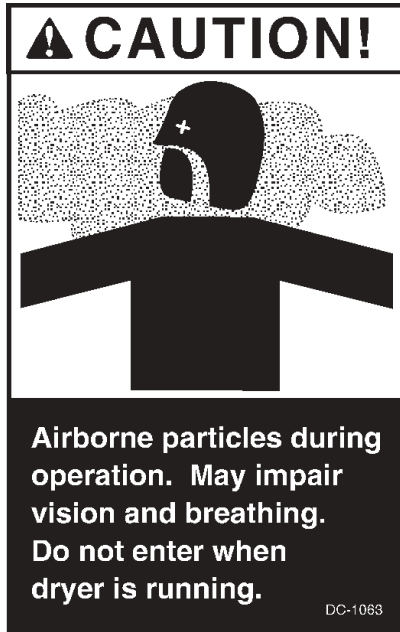

Safety Decal # DC-1064

Location of Decal (1) on outside of cool section door.

Safety Decal

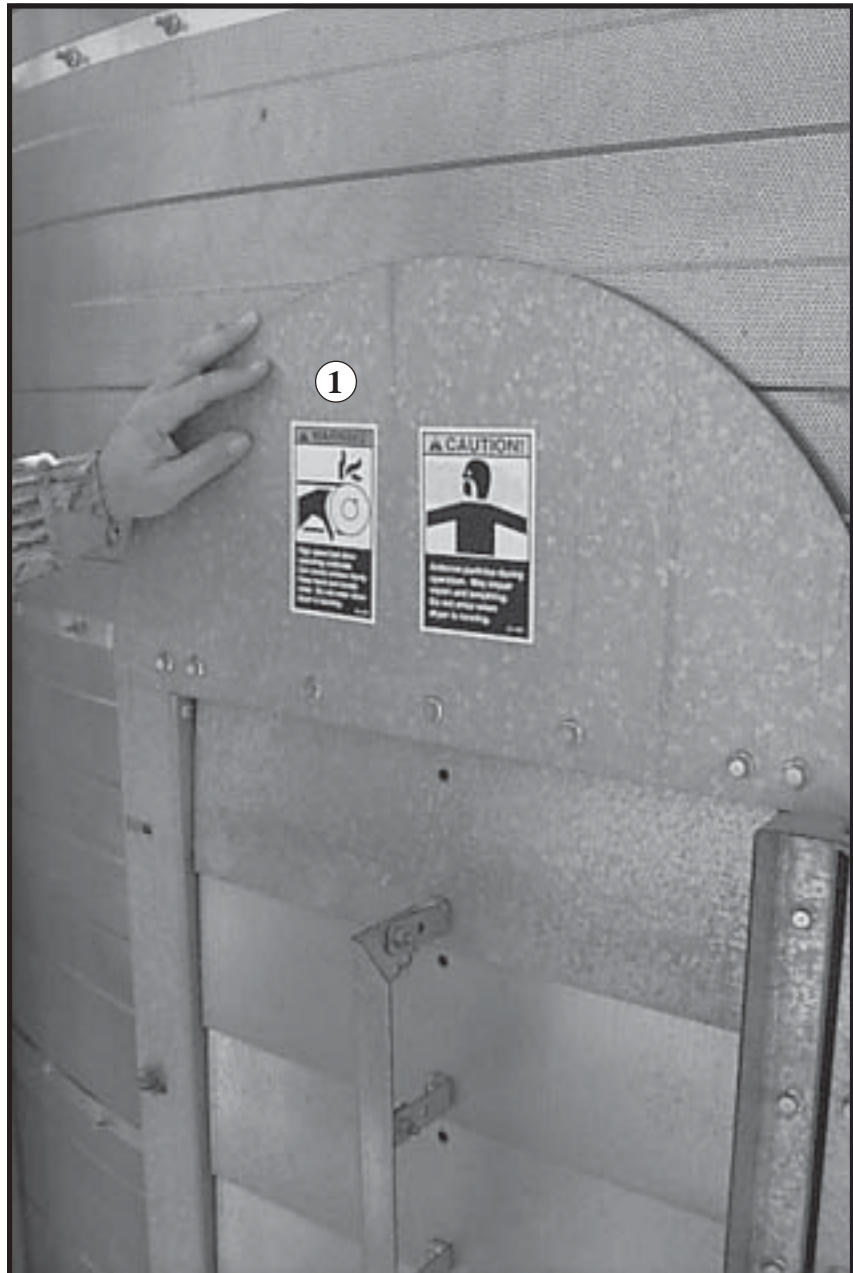

Safety Decal # DC-1182

Location of Decal (1) inside main power box,
on power panel next to fuse block.

Safety Decal

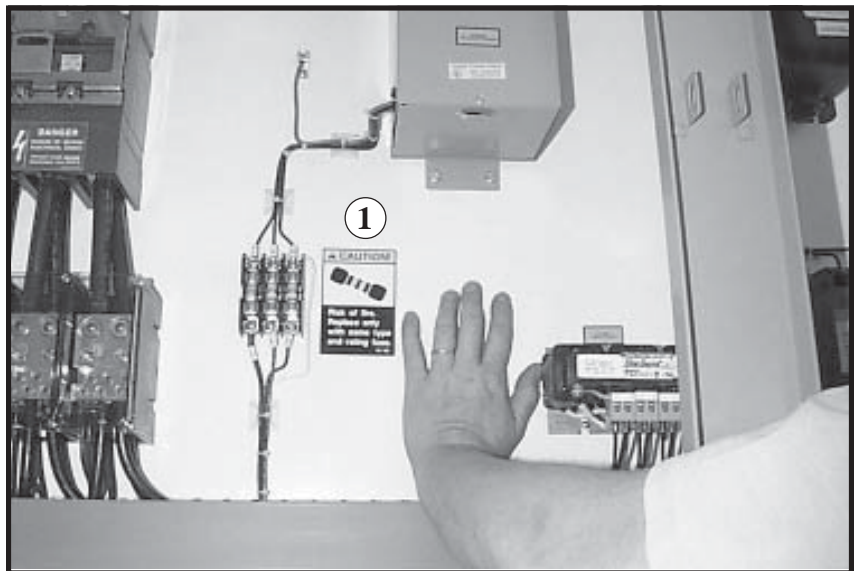



Safety Decal # DC-1223

Location of Decal (1) on outside of main power box door,
to left of main electrical disconnect.

Safety Decal

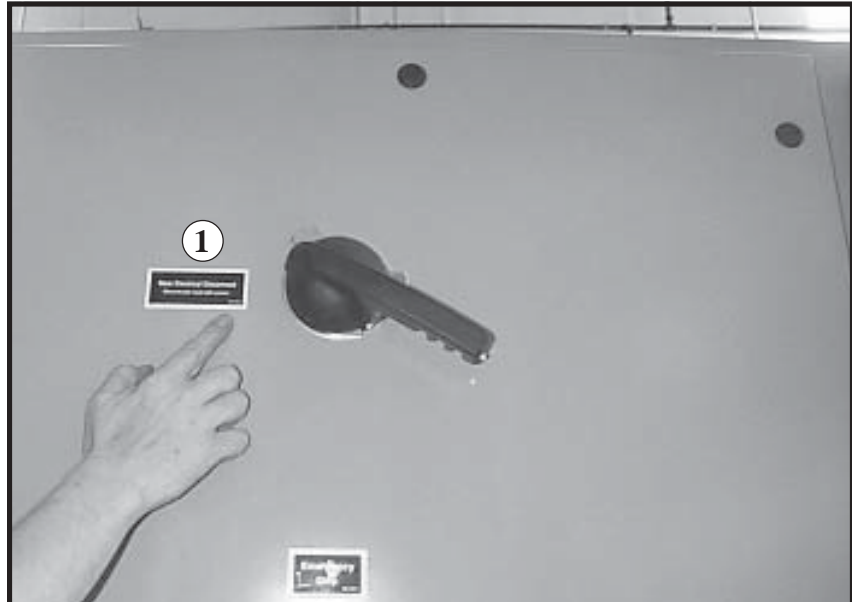
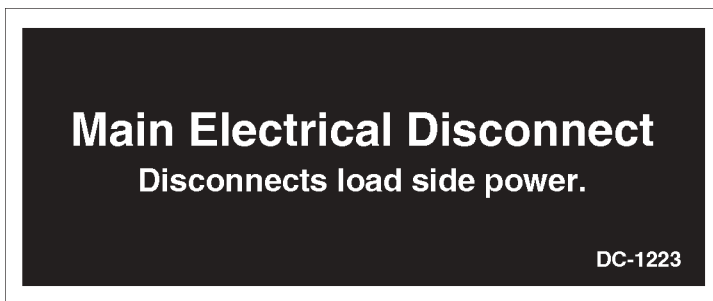

Safety Decal # DC-1317

Location of Decal (1) on outside of main power box door,
above emergency stop disconnect.

Safety Decal



Name Plate for Main Power Box

Location of Decal (1) inside main power box door,
on same side as main electrical disconnect.

Information Decal

Example

GSI		GSI	
		Assumption, IL 62510	
Model	4500T134NED		
Serial No.	03981032		
Fuel	NATURAL GAS		
Max. Total H.P.	230		
Max. Amperage	275		
Supply Voltage	3	Phase	400
		Volts	60
			HZ
		H.P.	Amp
Fan #4			
Fan #3	75		80
Fan #2	75		80
Fan #1	75		80
Metering	5		9
Load			
Unload			
Auxiliary 1			
Auxiliary 2			
Auxiliary 3			
Auxiliary 4			

**T
O
W
E
R

D
R
Y**

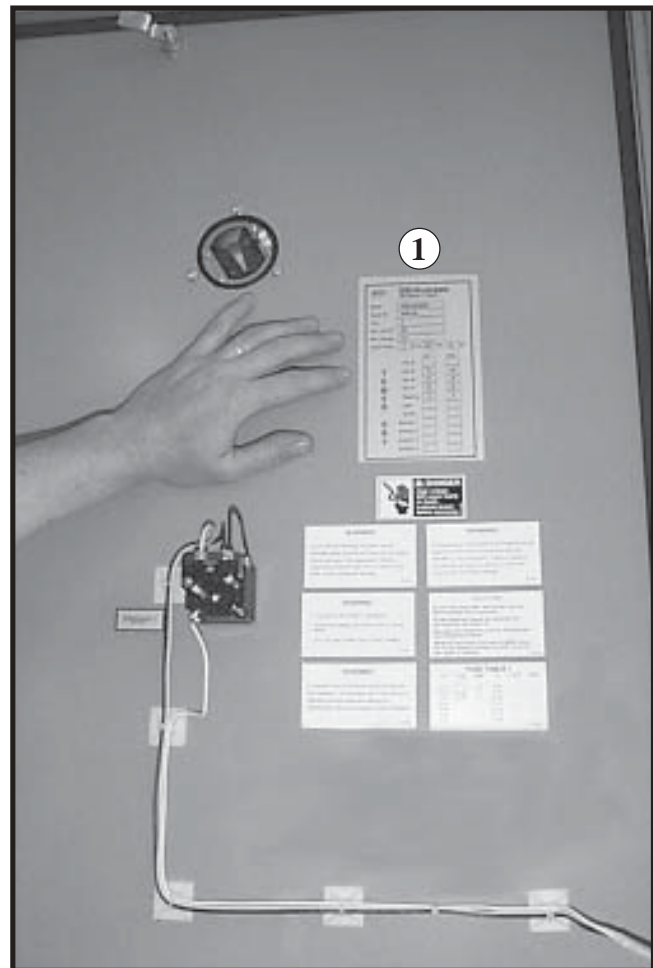

Illustration 1-1
Dryer Sections

Heat Section

Cool Section

Hopper

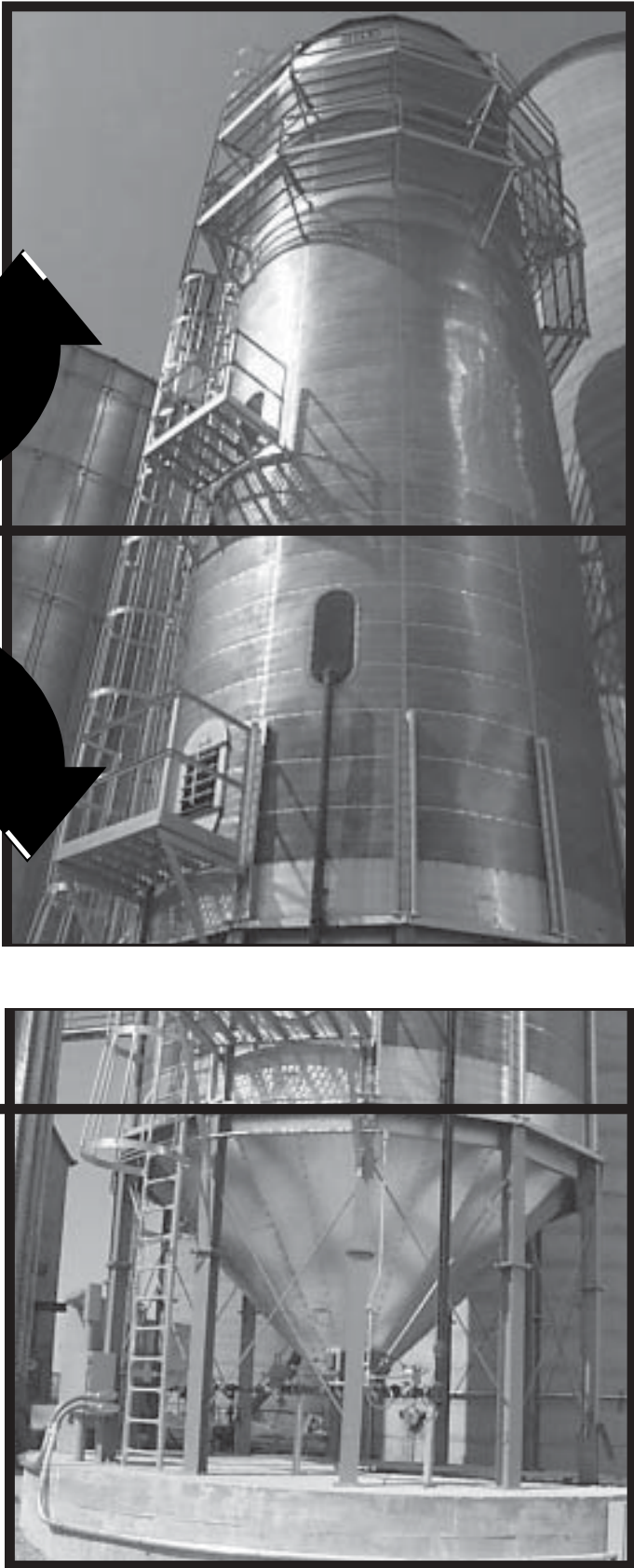

Photo 1-1

Dryer Structure Overview

The Tower Dryer is divided into three sections: Heat Section, Cool Section, and Hopper. The following major features are installed in these sections.

Heat Section is about 70% of dryer. Grain is loaded into top of tower dryer (between Tower Roof and Plenum Roof), and dried in Heat Section.

- Grain Turners, which turn grain so it dries uniformly, are located about midpoint.
- Inside Ladders and Catwalk give access to Slide Gates (clean-out) for Grain Turners.
- Burner, Burner Housing and Reducer are installed with X-bracing.
- There is (1) door to Heat Section. Larger dryers also have (1) door to Burner Housing.
- Reducer Walkway gives access to Burner.
- Outside Ladder with Safety Cage, Platforms, and Catwalks give access to Heat Section and outside sensors.
- Heat Section is separated from Cool Section by Divider Hopper. Fine grain debris falls from Heat Section, through Divider Hopper, for collection in Cool Section.

Cool Section is about 30% of dryer. Grain is cooled in Cool Section.

- Blowers are installed with X-bracing.
- Windows provide free air.
- There is (1) door to Cool Section.
- Outside Ladder with Safety Cage and Platform give access to Cool Section.
- Debris-tight Cool Section floor separates Cool Section from Hopper.
- There is (1) door to Hopper in Cool Section Floor.

Hopper unloads grain from dryer.

- Hopper is formed by Outside and Inside Hopper Wall Sheets.
- Metering Drum, Motor, and supports are installed in Hopper.
- Slide Gates (discharge) provide emergency discharge of grain.
- Compression Angles form base of grain columns and support Hopper.

Additional Features

Vertical Channels support the dryer from foundation to roof. Vertical Channels support rings of Inside Wall Sheets and Outside Wall Sheets to form grain columns through which grain flows down dryer. Dryer Legs install with X-rods at base of Vertical Channels.

Illustration 1-2
Components
all Models

- Fill Tube Weldment
- Tower Roof
- Tower Roof Access Port
- Outside Ladder & Safety Cage
- Outside Landings
- Wall Sheets & Grain Column
- Grain Exchangers & Slide Gates - Cleanout
- Inside Landings & Ladder
- Heat Section - Burner
- Reducer & Reducer Walkway
- Cool Section - Blowers
- Blower X-Bracing
- Divider Hopper
- Blower Motors
- Windows & Doors
- Base Stiffeners
- Compression Angles
- Dryer Legs
- Discharge Hopper
- Metering Drum & Metering Drum Motor
- Slide Gates - Emergency Discharge
- Electrical Control System

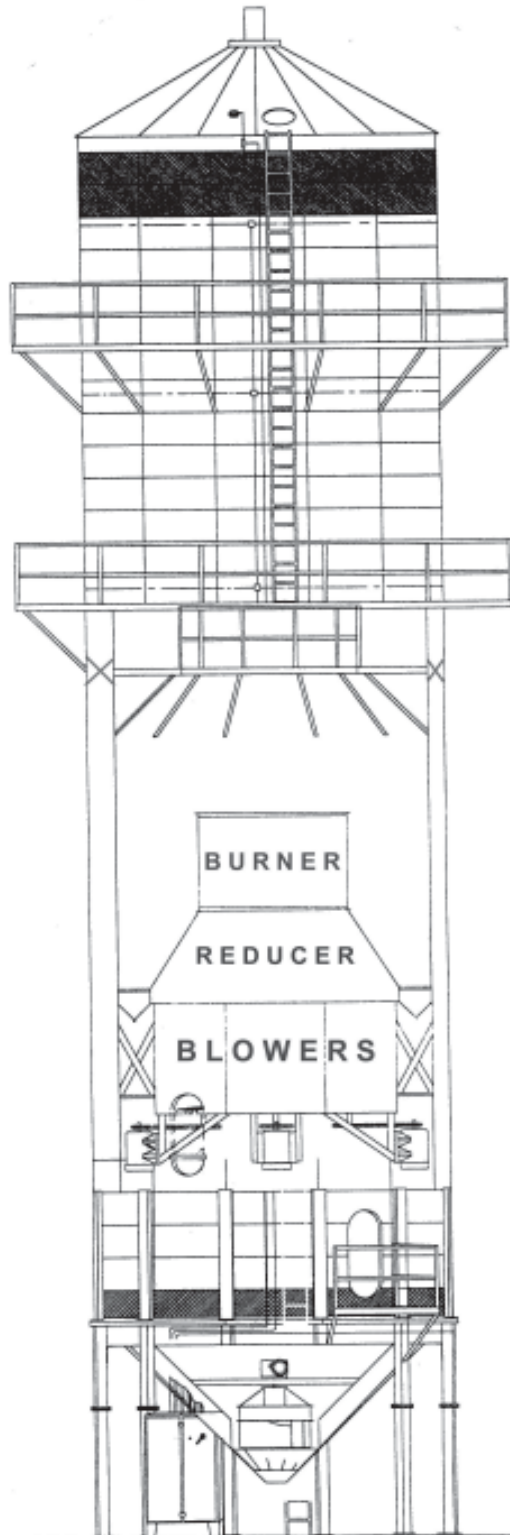

- Indicator(s)
- Grain Temperature Sensors
- Outside Hi-Limits (overheats)

1 Orientation Wall Sheets & Vertical Channels

18' Tower Dryer Construction

Illustration 1-3

Dimensions for *all Models*

There are four models of 18' diameter dryers, #2500, #3000, #3500, and #4000. These dryers are named for their bph (Bushels Per Hour capacity based on 20% to 15% moisture content).

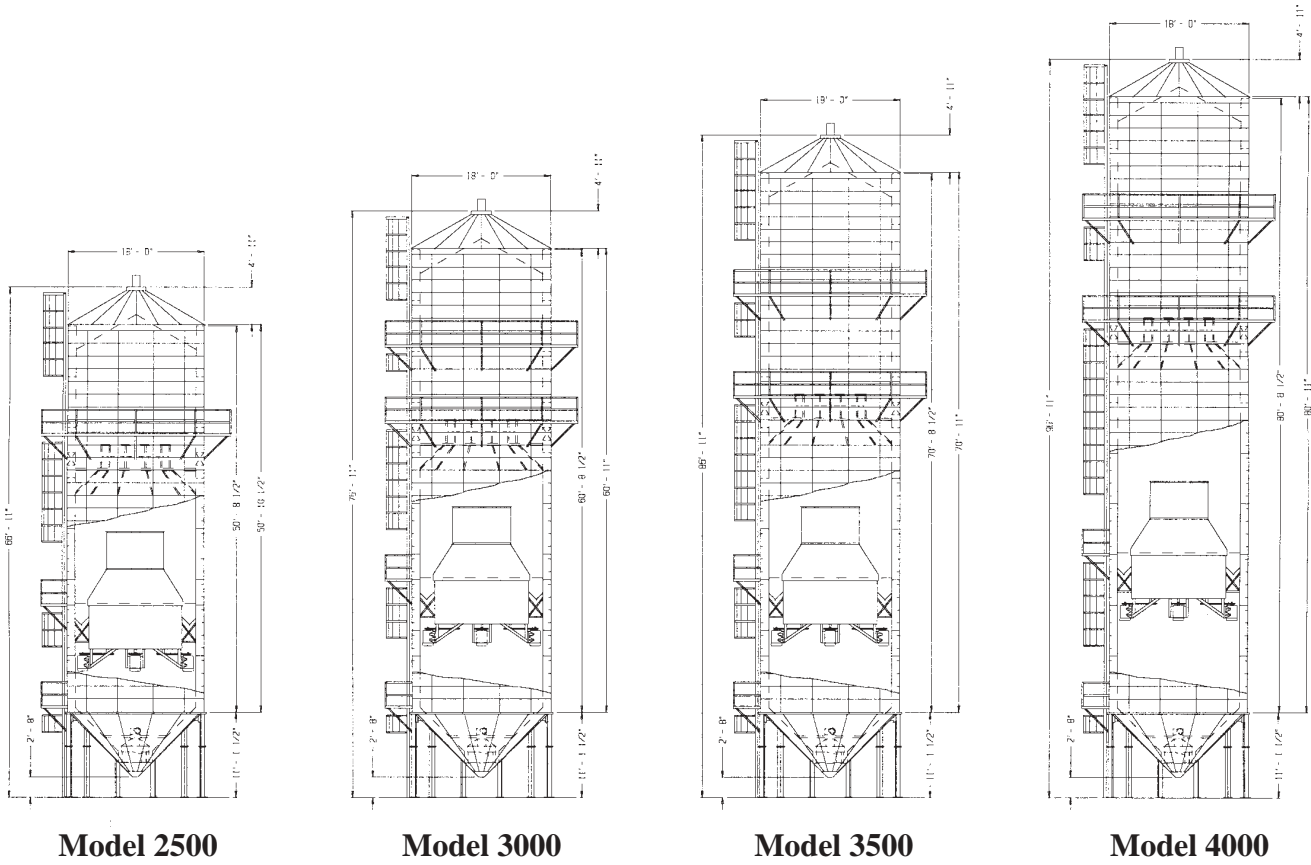

Aerial View

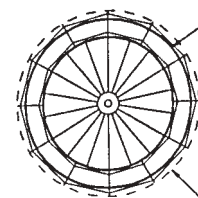

Minimum Foundation = 23'

Catwalk Clearance = 12' 8"
(from center of dryer)

	Model #			
	2500	3000	3500	4000
Grain Column Depth	12"	12"	12"	12"
Tower Diameter	18'	18'	18'	18'
Grainwall Height	50'-8"	60'-8"	70'-8"	80'-8"
# of Grain Columns	12	12	12	12

Illustration 1-4
Dryer Dimensions - Detail
Model 2500

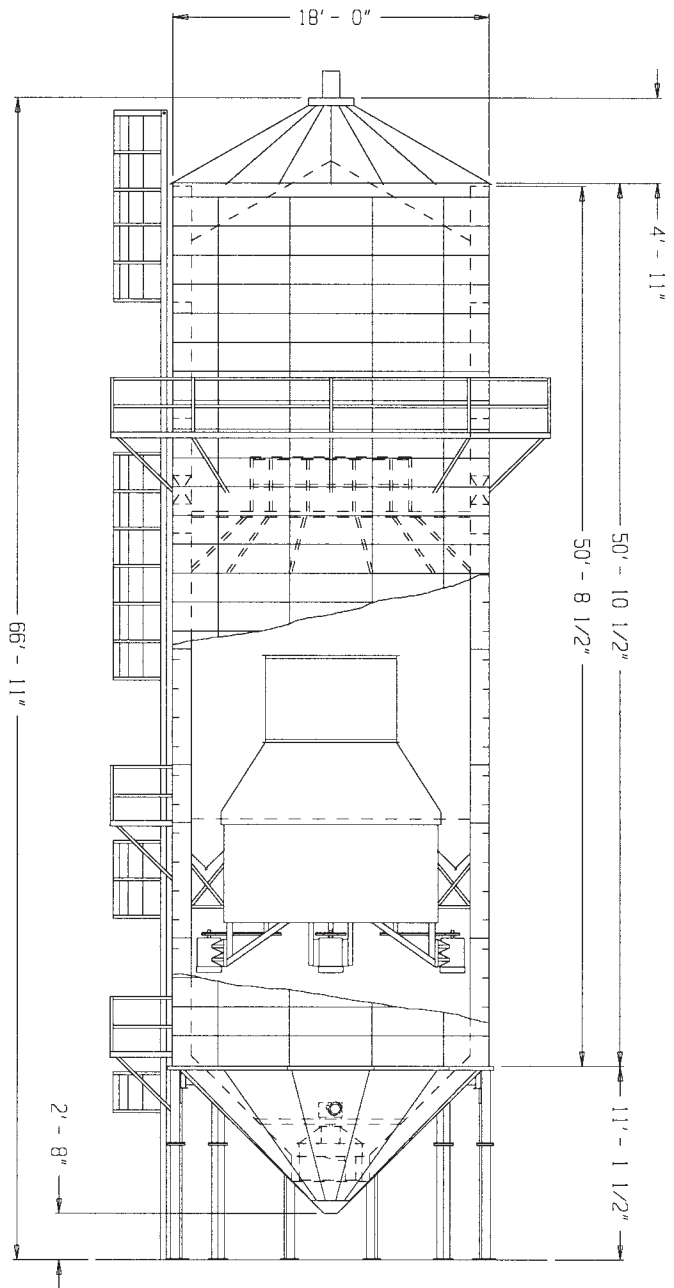

1 Orientation Wall Sheets & Vertical Channels

18' Tower Dryer Construction

Illustration 1-5
Dryer Dimensions - Detail
Model 3000

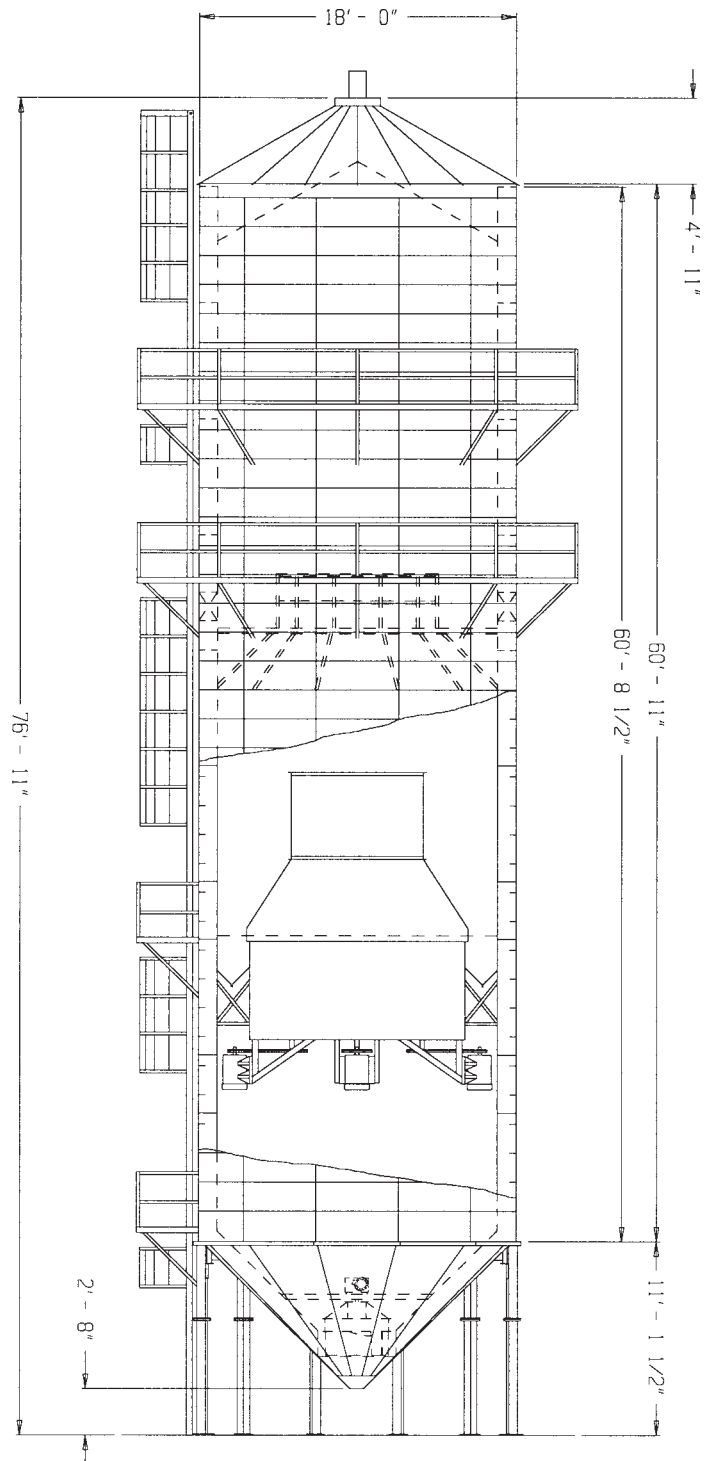
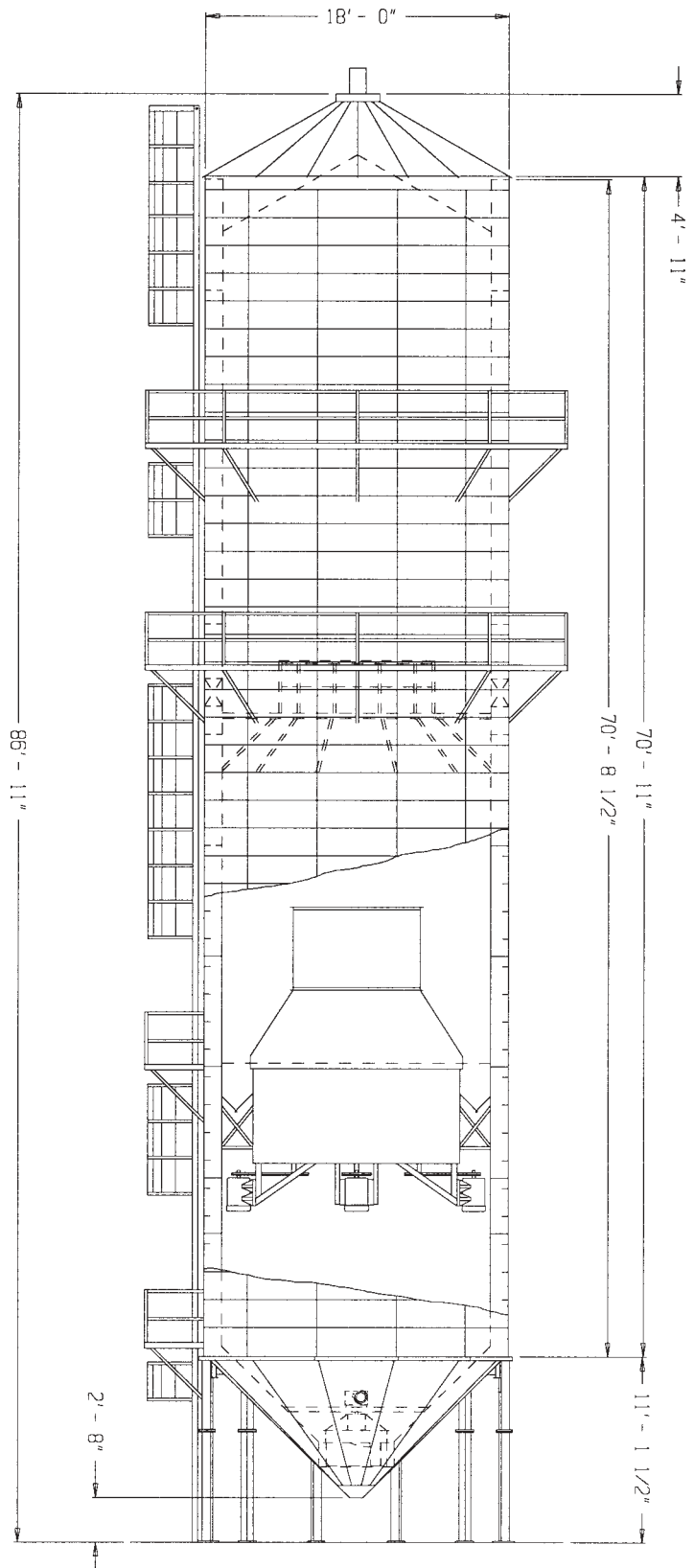

Illustration 1-6
Dryer Dimensions - Detail
Model 3500



1 Orientation Wall Sheets & Vertical Channels

18' Tower Dryer Construction

Illustration 1-7
Dryer Dimensions - Detail
Model 4000

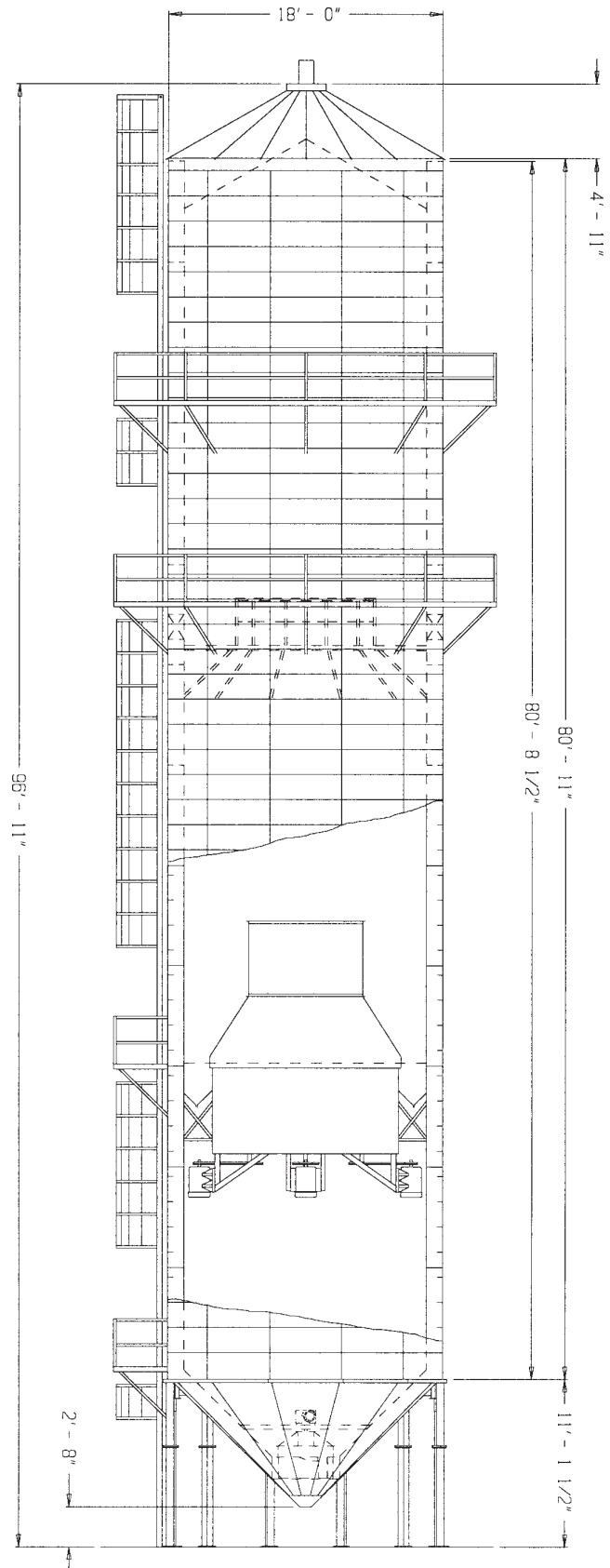

Pre-Assembly

This construction manual provides directions for installation of parts starting at the top section of the dryer and building down. Some installations can be done simultaneously, and some can be pre-assembled.

The following installations can be pre-assembled on the ground before installing them to the dryer.

- Interior and Exterior walkway sections. (Catwalk and Platform)
- May need to pre-assemble Reducer Housing.
- May need to pre-assemble Burner Housing.
- Bolt a splice to each channel before installing it to the preceding channel.
- Top Safety Cage can be pre-assembled on the ground before installing it to the dryer.

It is recommended that the remaining ladder and safety cage sections not be pre-assembled. Install them directly to the dryer.

Ladder Installation

- Roof Access Port, Bindicator(s), and Grain Temperature Sensors must be accessible from outside tower ladder.
- Install Outside Ladder one bolt hole to the left of a Vertical Channel. Install Outside Ladder so it will terminate with clearance from dryer legs.

Layout & Clearance

Plan ahead to locate tower dryer for the convenience of the dryer operator, and in correct orientation to existing equipment and structures.

Consider the following when planning dryer layout.

- Dryer orientation cannot be rotated after start of construction.
- Determine where utilities will come into dryer. Locate dryer electric and fuel intake accordingly.
- Plan dryer leg placement so that when dryer is complete, grain unload conveyor is centered between two dryer legs.
- Landings (Catwalks and Platforms) are 42" wider than the perimeter (wall) of the dryer. Plan an additional 42" for lateral clearance from existing equipment and structures. Total lateral clearance with landings is 12'-8" from center of dryer.
- Estimate finished dryer height and check for overhead clearance from electrical power lines, equipment and structures.
- Follow Wall Sheet assembly diagram for ladder, platforms, door, windows and sensor placement. However, these components can be relocated to some degree for convenience.

1 Orientation

Wall Sheets & Vertical Channels

18' Tower Dryer Construction

Layout & Clearance continued

- Locate the Electrical Control System (consists of Power Box and Control Box) for the convenience of the dryer operator, where visibility and access are best.

Can locate Control Box directly below a Motor Window to allow installation of wiring conduit in a direct run.
- The Fuel Train (with Maxon Gas Valves, Modutrol Motor, Pilot Fuel Train, and Pilot Solenoid) is usually anchored to the foundation directly below the dryer, or secured to dryer legs.
- The Fuel Piping enters the dryer through a window in the Cool Section, then runs up the center of the dryer to the Burner in the Heat Section.

Contact Grain Systems for assistance in planning tower dryer layout.

Foundation

Tower dryers should be installed on reinforced concrete foundations.

For such foundations, engineering usually requires the following information:

- Soil analysis and bearing strength.
- Climatic and seismic conditions for the location.
- Size and weights of the dryer, both empty and full of grain.
- Specifications for the concrete and reinforcing steel to be used in the construction.

Contact Grain Systems for assistance in assessing tower dryer foundation requirements.



✓ Safety Check

before each lift of dryer.

Check for clearance from existing power lines, equipment and structures.

Illustration 1-8
Sheet Layouts
Model 2500

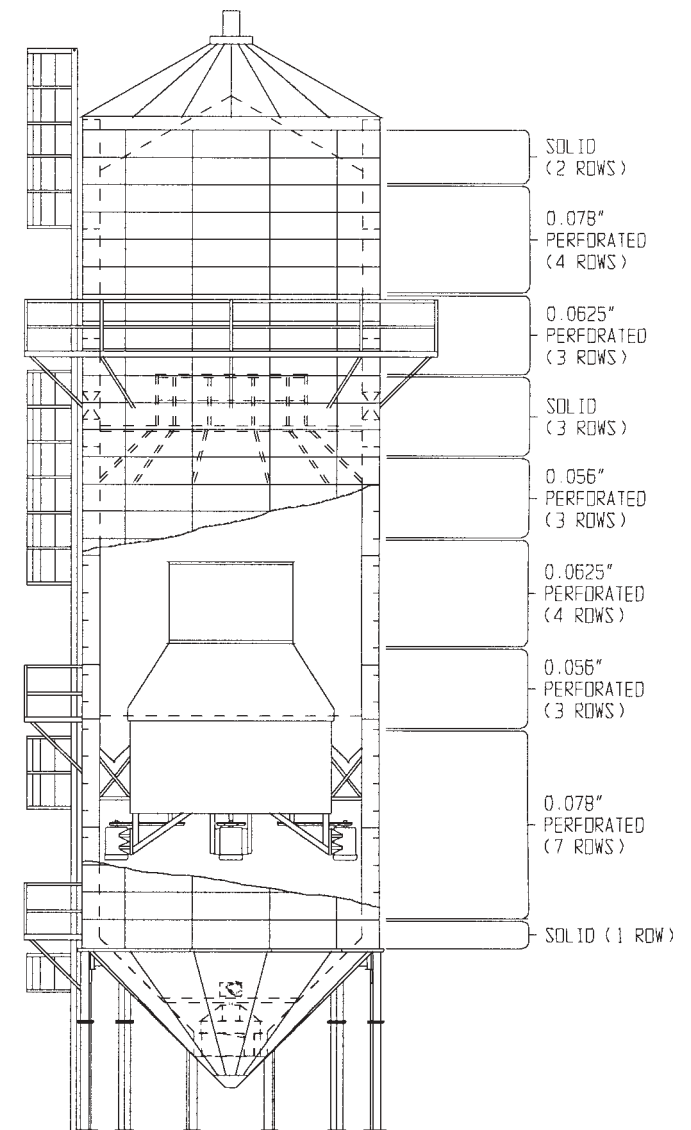

1 Orientation Wall Sheets & Vertical Channels

18' Tower Dryer Construction

Illustration 1-9
Sheet Layouts
Model 3000

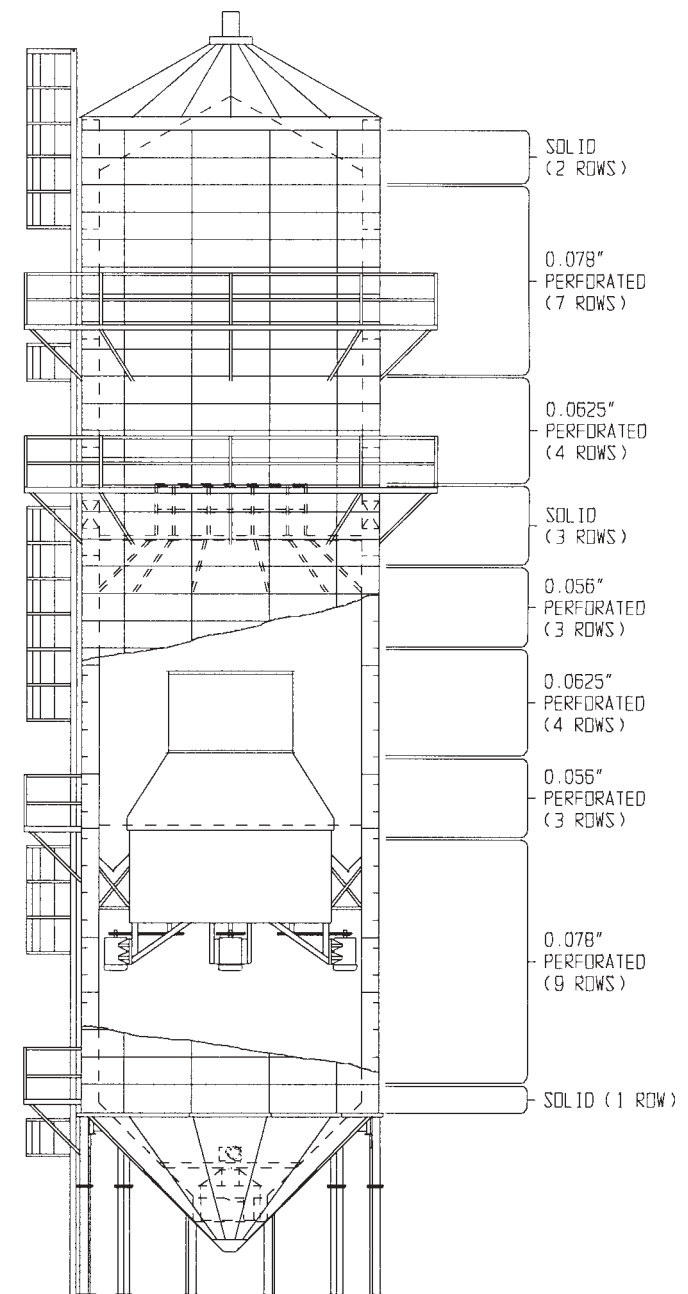
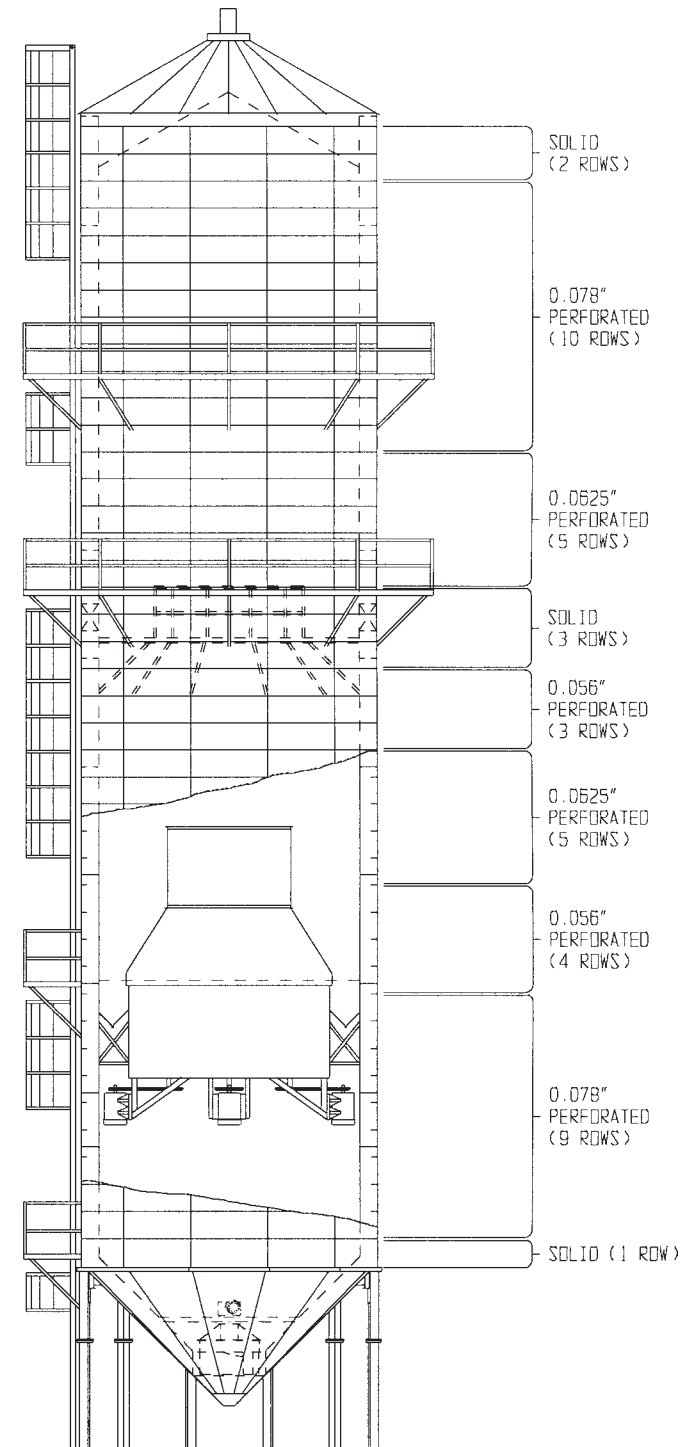

Illustration 1-10
Sheet Layouts
Model 3500



1 Orientation Wall Sheets & Vertical Channels

18' Tower Dryer Construction

Illustration 1-11
Sheet Layouts
Model 4000

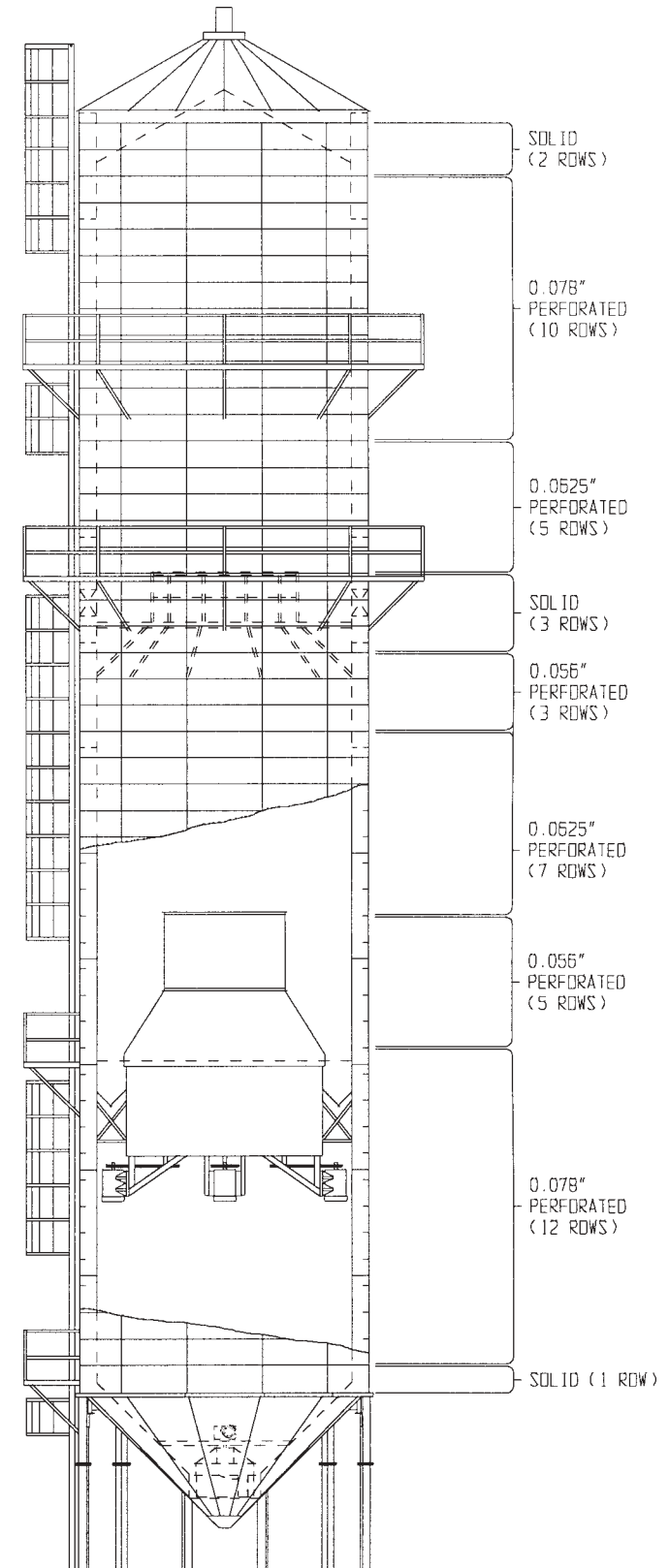
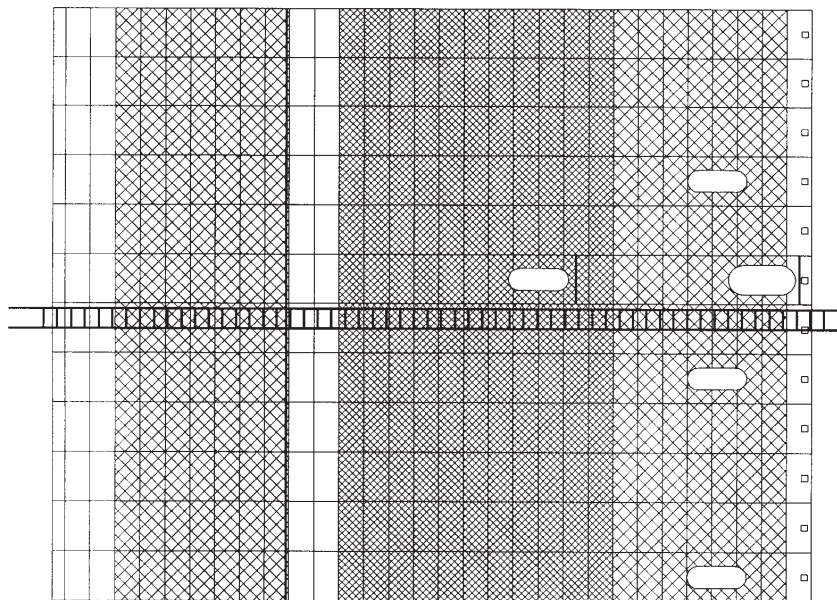
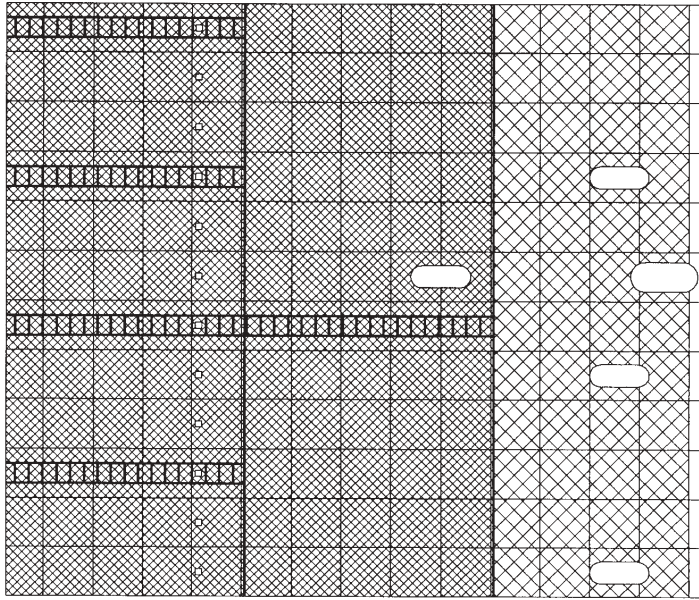

Illustration 1-12
Flat Layout
Model 2500



1 Orientation Wall Sheets & Vertical Channels

18' Tower Dryer Construction

Illustration 1-13
Flat Layout
Model 3000

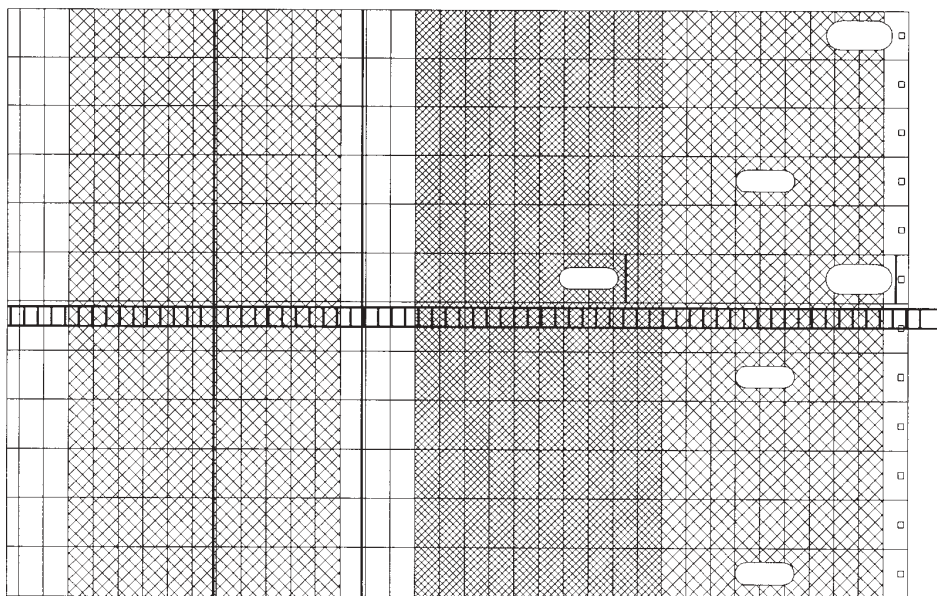
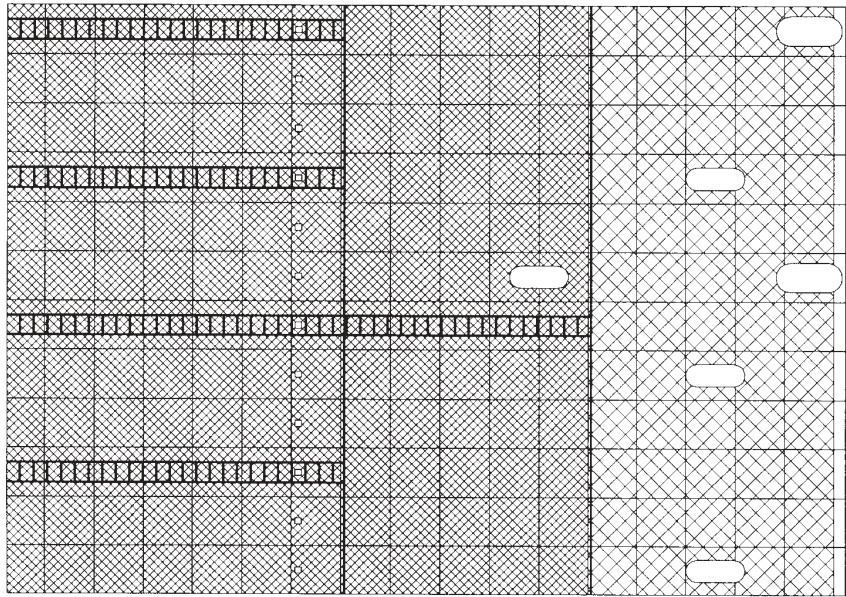
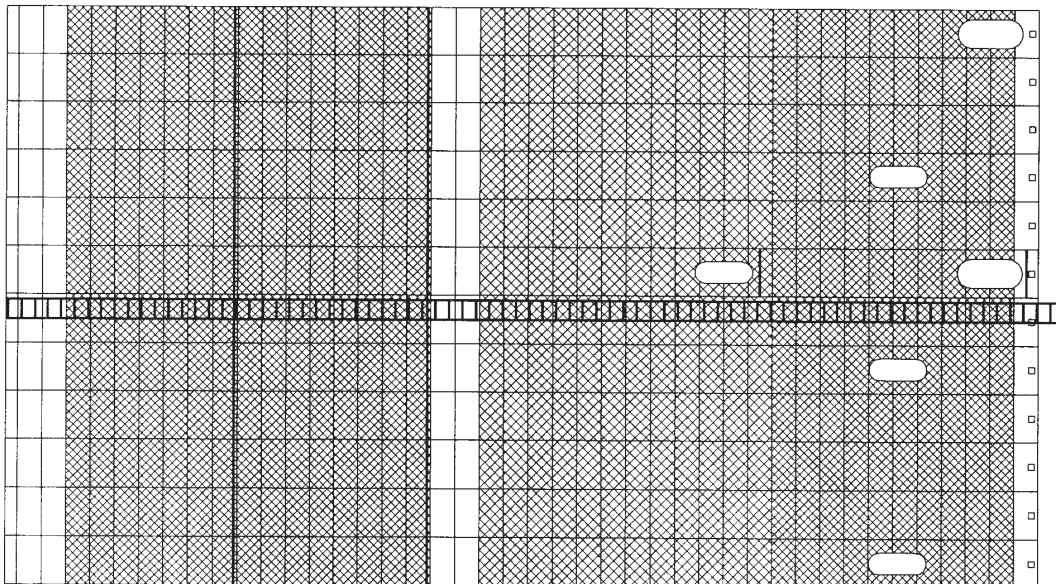
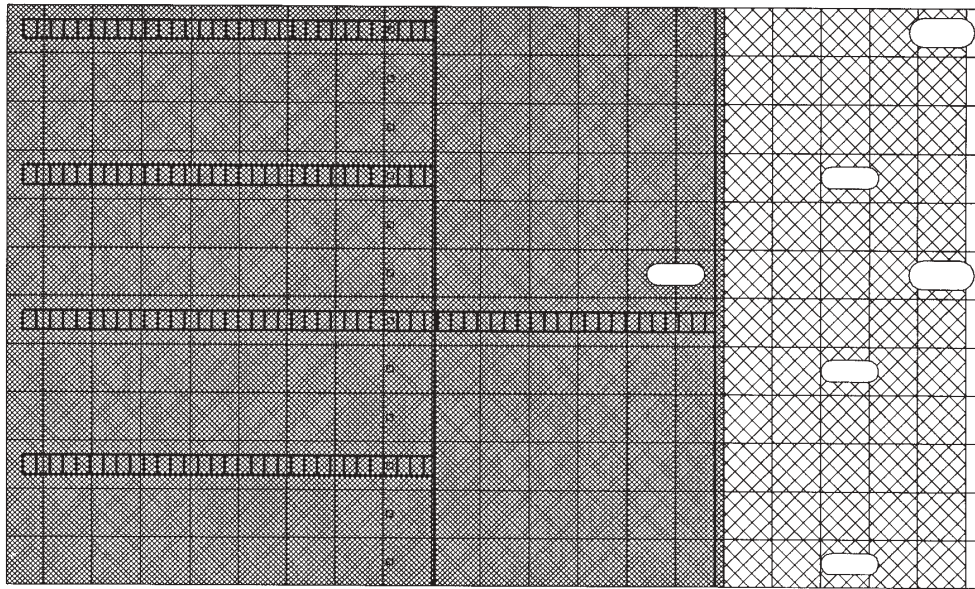

Illustration 1-14
Flat Layout
Model 3500



1 Orientation Wall Sheets & Vertical Channels

18' Tower Dryer Construction

Illustration 1-15
Flat Layout
Model 4000

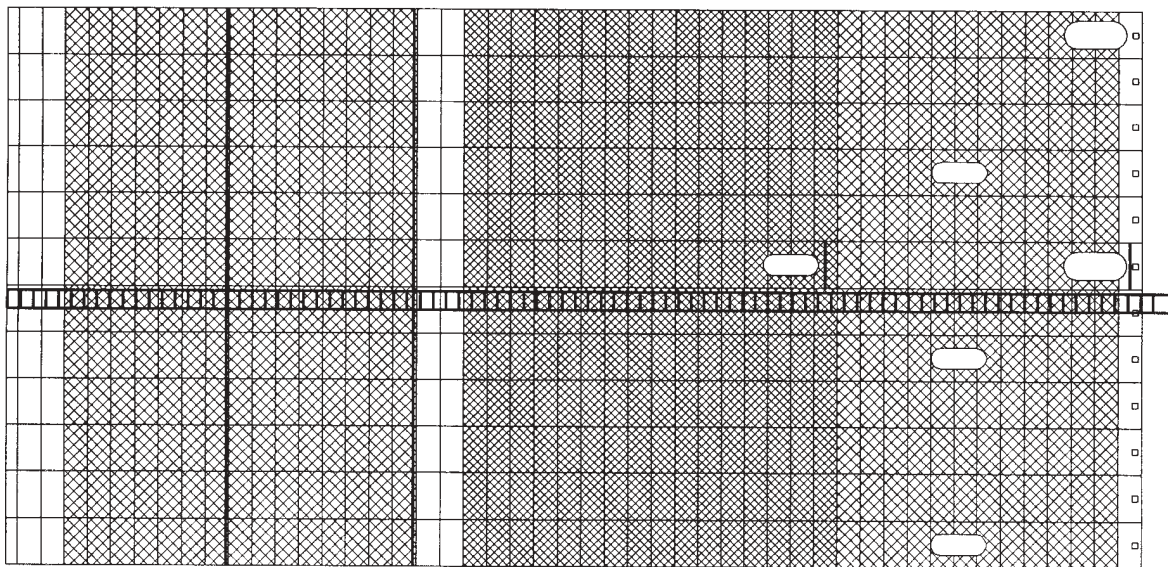
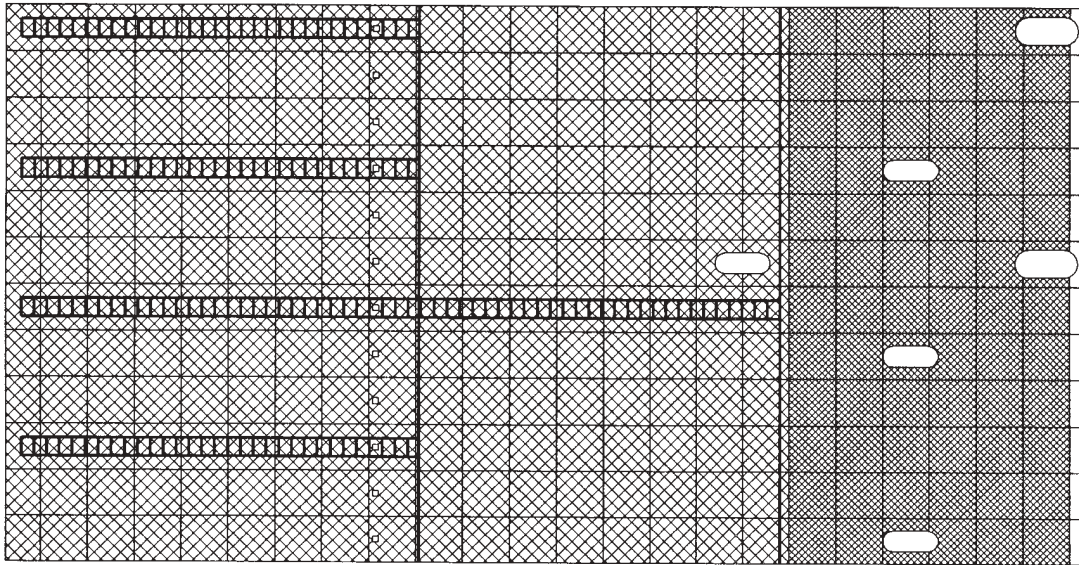

Illustration 1-16
Wall Sheets Overlap
(exterior view)



Photo 1-2

Throughout Dryer
Wall Sheets are installed in overlapping rings around dryer, starting at dryer top and working down. Each ring of sheets vertically overlaps the ring of sheets above it so that grain does not lodge between. Each sheet installed horizontally overlaps the previous sheet in the ring. In Illustration 1-8 above, sheet (B) laps sheet (1A), (C) laps (B), and so on around the dryer. Each ring of sheets is installed to lap over previous ring sheets already installed above it on dryer: (2) laps (1A), (3) laps (2), and on down dryer.

(cross section)

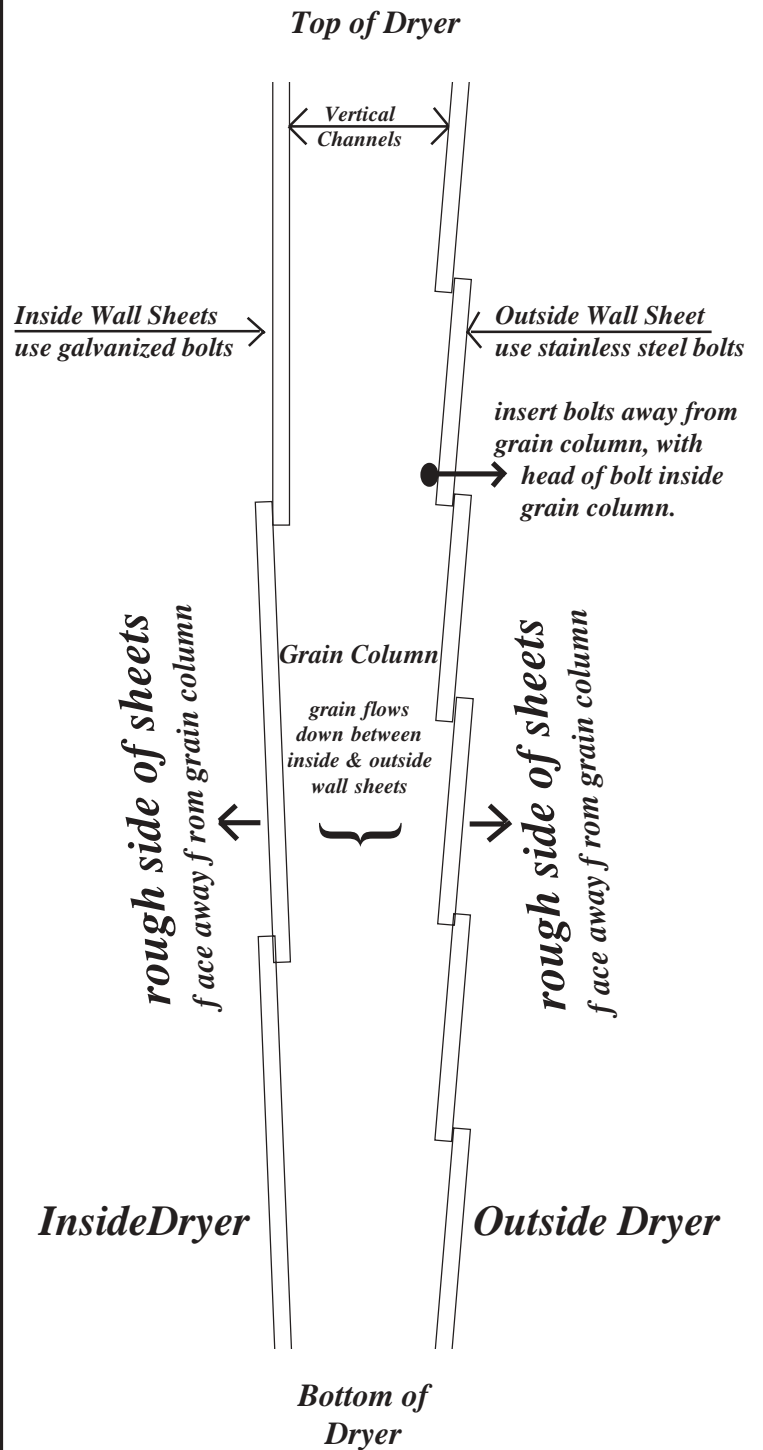

Wall Sheet Comparison

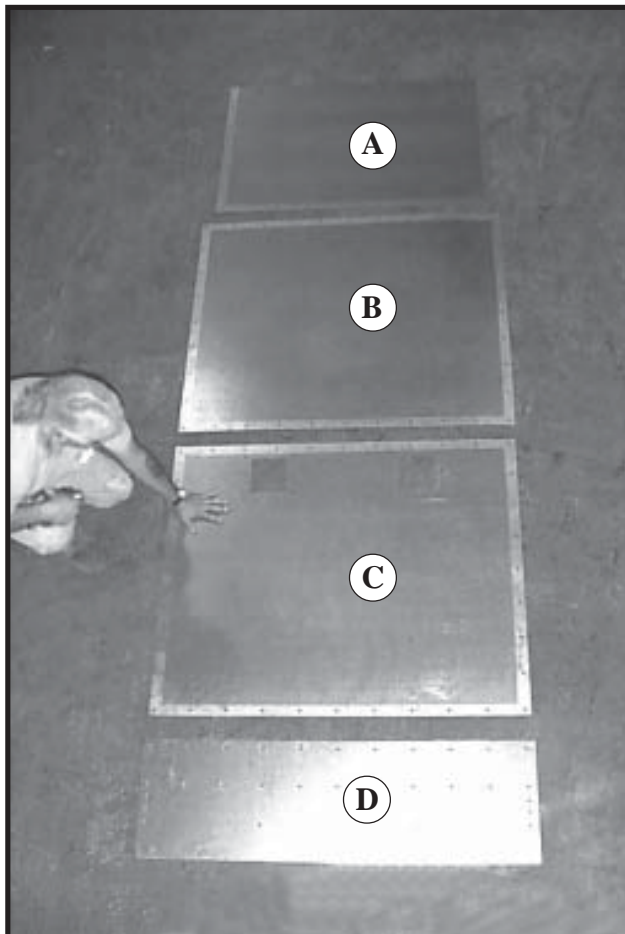

Photo 1-3

INSIDE WALL SHEETS - GALVANIZED

- A. Inside Top Wall Sheet (perforated), 30" high
Use for inside Plenum Roof wall.
- B. Inside Heat/Cool Wall Sheet (perforated), 40" high
Use same part to form Inside Heat Wall
and Inside Cool Wall.
- C. Inside Cleanout Wall Sheet (perforated), 40" high
(with Slide Gate cut outs for Grain Turner clean out)
- D. Inside Bottom Wall Sheet, Solid, 15-1/2" high

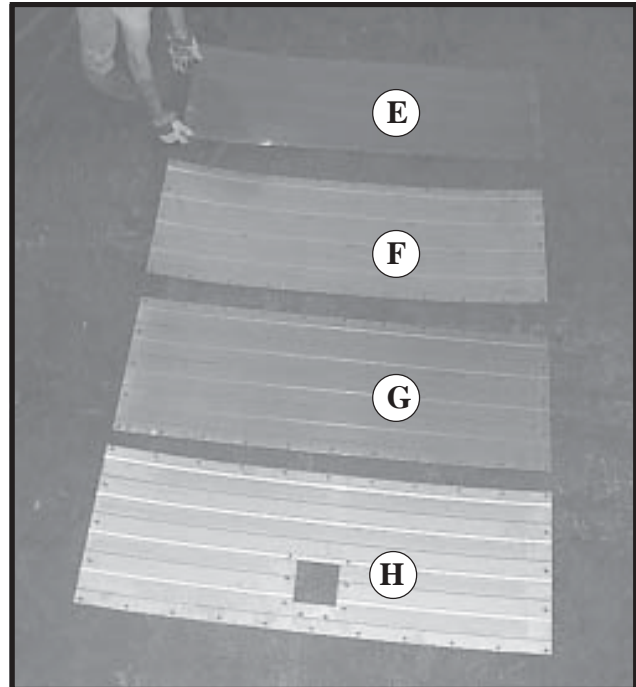

Photo 1-4

OUTSIDE WALL SHEETS - STAINLESS STEEL

- E. Outside Wall Sheet, Perforated, 20" high
.078" (big hole)
- F. Outside Wall Sheet, Solid, 20" high
Use for first 2 rows of wall of outside Tower Roof
and rows where Grain Turners are installed.
- G. Outside Wall Sheet, Perforated, 20" high
.0625" (little hole)
- H. Outside Bottom Wall Sheet, Solid, 20" high
(with Slide Gate cut outs for base of dryer
emergency discharge)

To minimize the release of fine debris from dryer, install sheets as follows. Install .078" perforated sheets down to Grain Turners. After grain is turned, install .0625" perforated sheets. Install solid sheets at Grain Turners, and at top and bottom of grain columns.

Wall Sheet Guidelines

Inside Wall Sheets (& hardware) are galvanized, and form plenum chamber wall of dryer.

Outside Wall Sheets (& hardware) are stainless steel, and form tower wall of dryer.

These two walls of the dryer are separated by columns of Vertical Channels. This structure forms Grain Columns through which grain flows.

Each perforated Wall Sheet has a rough side and a smooth side. Install Wall Sheets so the rough side is away from grain column. This reduces grain sticking to Wall Sheets and allows grain to flow freely down grain column. (See Illustration 1-8, "Wall Sheets - Overlap")

Install Wall Sheets to Vertical Channels so Wall Sheets overlap as explained in Illustration 1-8.

Plan ahead and leave out a Vertical Channel and some wall sheets where necessary to bring Burner, Reducer, and Blowers into dryer. (Install Rolled Plenum Channels temporarily as required to maintain shape and stability.)

Bolts. In each section of dryer, loosely install all bolts to Wall Sheets and common bolts through Rolled Plenum Channels reinforcing Wall Sheets before tightening bolts in that section of dryer.

Insert bolts so that bolt head is in the grain column. This reduces collection of fines (fine debris from grain), and allows grain to flow freely. (See Illustration 1-8.)

Do not fill bottom bolt holes in ring of Wall Sheets. Install next ring of Wall Sheets with common bolts in bottom bolt holes in previous Wall Sheets.

Leave out some bolts for lifting brackets.



On vertical Wall Sheet seams, (plumb, up and down) use 5/16" x 1" hex head bolts and nuts.

On horizontal Wall Sheet seams, (level, left and right) use 5/16" x 3/4" hex head bolts and nuts.



Use washers where there is a possibility of leaking.

To tighten bolts, work around the ring of Wall Sheets, tightening horizontal seams, then vertical seams.

To avoid wrinkling Wall Sheets when tightening bolts, work in pairs. One person (standing in grain column) holds alignment punches in top and bottom holes of Wall Sheets to align them to Vertical Channel holes. Second person (standing outside grain column) tightens each nut with impact wrench. Drill out misaligned stainless steel Wall Sheets. While one worker is tightening horizontal bolts on outside sheets, second worker (inside grain column) presses outside sheets outward.

When installing wall sheets, install support clips to them for parts such as catwalks, platforms, bracing, etc.

Rolled Plenum Channels

Rolled Plenum Channels are spliced with Plenum Channel Splices, and installed in rings to inside Wall Sheets. Install 20" apart, and down length of dryer. If necessary to clear another part, shift a Rolled Plenum Channel ring up or down 5" (10" maximum).



Splice to Rolled Plenum Channel, use 5/16" x 1" whiz bolts. Rolled Plenum Channel to Wall Sheet, use 5/16" x 3/4" whiz bolts.

1 Orientation Wall Sheets & Vertical Channels

18' Tower Dryer Construction

Illustration 1-17 Wall Sheet Attachment Guidelines *all Models*

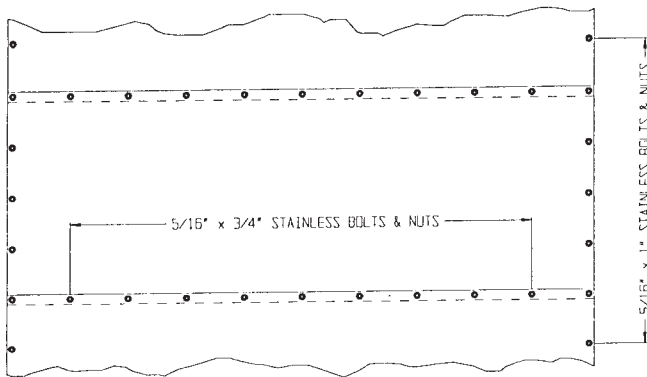

Outside Sheets

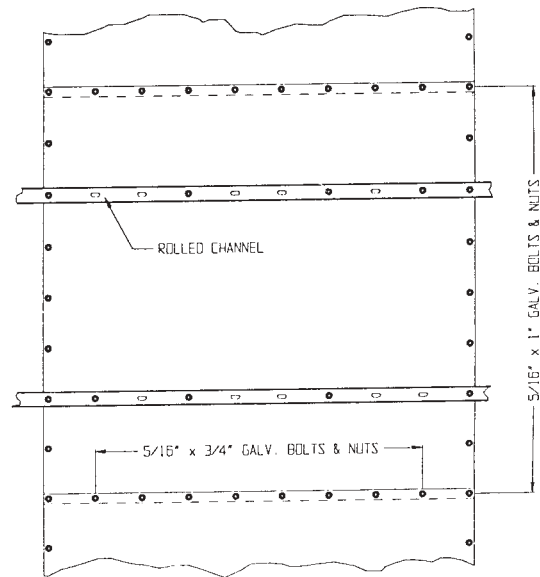

Inside Sheets

Illustration 1-18
Inside Wall Sheet Placement
all Models

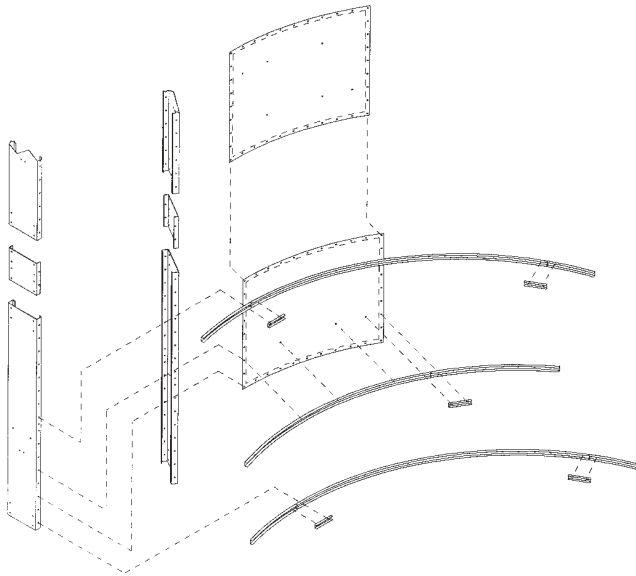

Inside Wall Sheet
(expanded view)

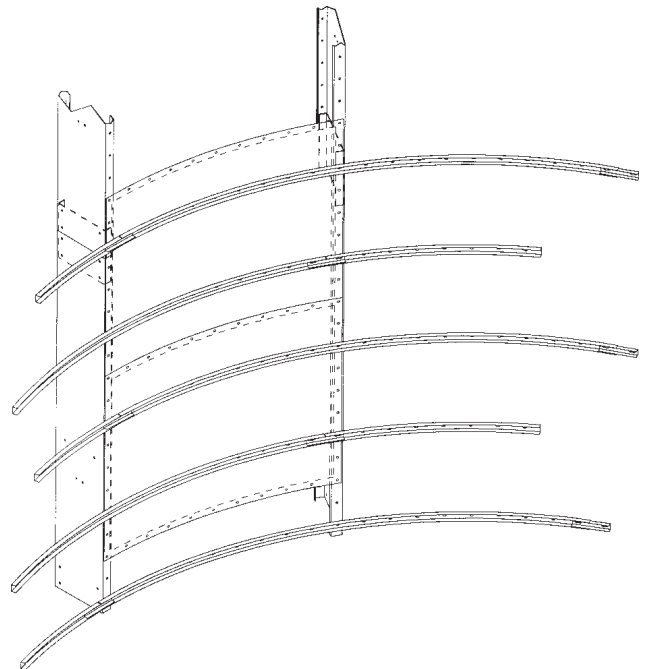

Inside Wall Sheet
(assembled view)

1 Orientation Wall Sheets & Vertical Channels

18' Tower Dryer Construction

Illustration 1-19
Outside Wall Sheet Placement
all Models

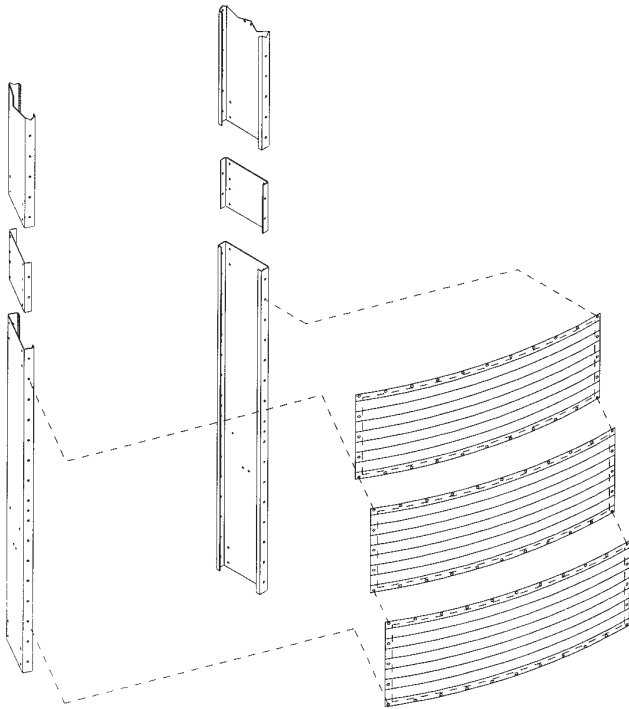

Outside Wall Sheet
(expanded view)

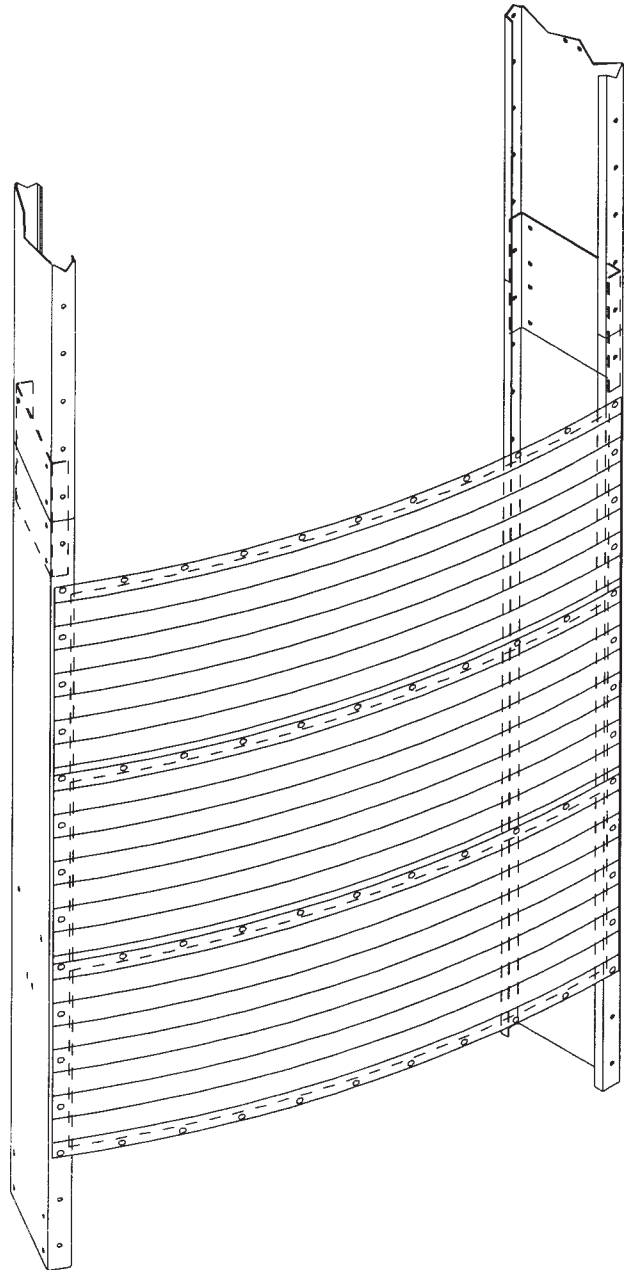

Outside Wall Sheet
(assembled view)

Example - Installing Wall Sheets to Roof



Photo 1-5 Hanging Inside Wall Sheets.



Photo 1-6 Installing Rolled Plenum Channels.



Photo 1-7 Close Up - Installing Rolled Plenum Channels.



Photo 1-8 Tightening Inside Wall Sheets.



Photo 1-9 Installing Lift Brackets to Outside Wall Sheets of Tower Roof.

Lifting Dryer Guidelines

Tower Dryer is built from roof down, rather than from the ground up. Dryer is lifted to install each set of Vertical Channels and other components. From below dryer roof to Hopper, each lift will have two rows of Inside Wall Sheets and four Rows of Outside Wall Sheets installed to each set of Vertical Channels.

Customarily, jacks are used to lift dryer during construction. Eight 10,000 pound, 14' lift jacks with hoisting tackle should be sufficient.

Place jacks 11-1/2" to 12" from dryer wall. Place first jack on LH side of Outside Ladder (Safety Cage may obstruct RH side). Space remaining jacks equally around dryer so that each jack will lift approximately the same share of the dryer weight. Center each jack between the (2) Vertical Channels it will lift. Level and plumb jacks. Anchor jacks as specified by manufacturer.



Take care during lift of dryer to avoid injury to personnel or damage to dryer and other structures. Do not lift dryer when it is windy enough to shift jacked dryer.

The dryer is heavier with each successive lift. Use a sufficient number of jacks to support the increasing weight of the dryer. Begin with the number of jacks required (usually 4) and add more jacks as dryer weight increases.

Follow jack manufacturer's instructions to attach and operate jacks, and lift dryer. In general, place an even amount of tension on each jack cable so dryer will rise evenly and smoothly. Maintain a smooth, steady motion during the lift to avoid wrinkling Wall Sheets.

Refer any questions to a qualified rigger.

Lift Bracket Installation.

Install (2) Lift Brackets to dryer for each jack when bolting on the bottom row of Outside Wall Sheets. From bottom of Vertical Channel, use bolt holes 3, 4, 5, 6, 7, and 8.

Span (2) Lift Brackets with lift bar so jacks do not block vertical rows of bolt holes.



Use 3/8" x 1-1/4" galvanized bolts and nuts.



Initial Lifts.

Bolt through Vertical Channels and Outside Wall Sheets where Lift Brackets will go with 3/8" x 1", grade 8 bolts. Tighten nuts, then install Lift Brackets over them. Secure with a second nut.

Blower Lift through Hopper Lift.

Bolt Lift Brackets flat against Wall Sheets and Vertical Channels for stability. Use more jacks.



Sweep any dropped bolts, debris from under dryer after each lift.

Vertical Channel Comparison

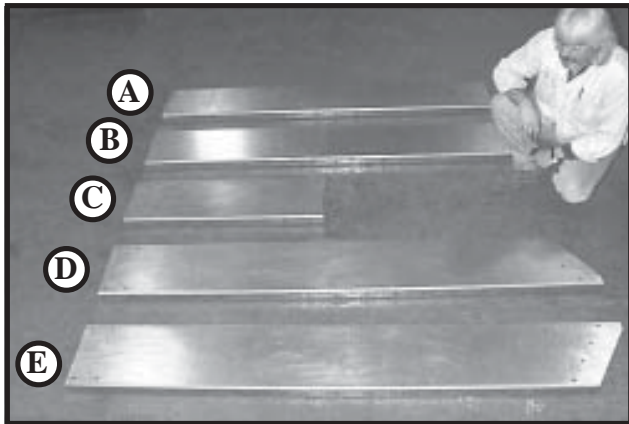

Photo 1-10 Vertical Channels.

- (A) Vertical Channel - 80", 10 gauge
- (B) Vertical Channel - 80", 8 gauge
- (C) Vertical Channel, 40", 8 gauge
Use as required to fill in Vertical Channel column.
- (D) RH Vertical Base Channel, 88-1/2",
installed at base of dryer,
- (E) LH Vertical Base Channel, 88-1/2",
installed at base of dryer,

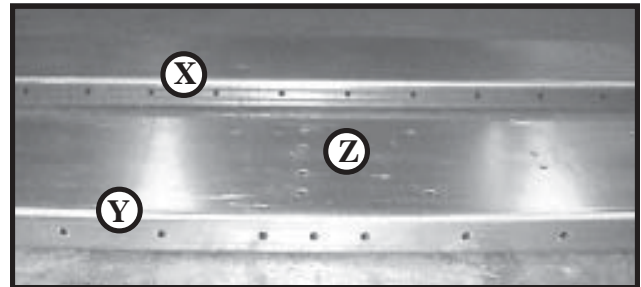

Photo 1-11 Close Up - Vertical Channels.

- (X) Vertical Channel - 80", 8 gauge
(Bolt holes in side are evenly spaced.)
- (Y) Vertical Channel - 80", 10 gauge
(Three bolt holes in center of side are spaced closely together.)
- (Z) On the widest side of all 10 gauge Vertical Channels there are two sets of bolt holes which are only used to install the Grain Turners.

VERTICAL CHANNELS

10 gauge Vertical Channels (lighter)
Generally installed from Roof down to Blower level.

8 gauge Vertical Channels (heavier)
Installed from Blower level down.

Larger dryers change gauge higher up.

Vertical Base Channels
Installed at base of dryer.

1 Orientation Wall Sheets & Vertical Channels

18' Tower Dryer Construction

Illustration 1-20 Column Layout

Model 2500

Model 3000

Model 3500

Model 4000

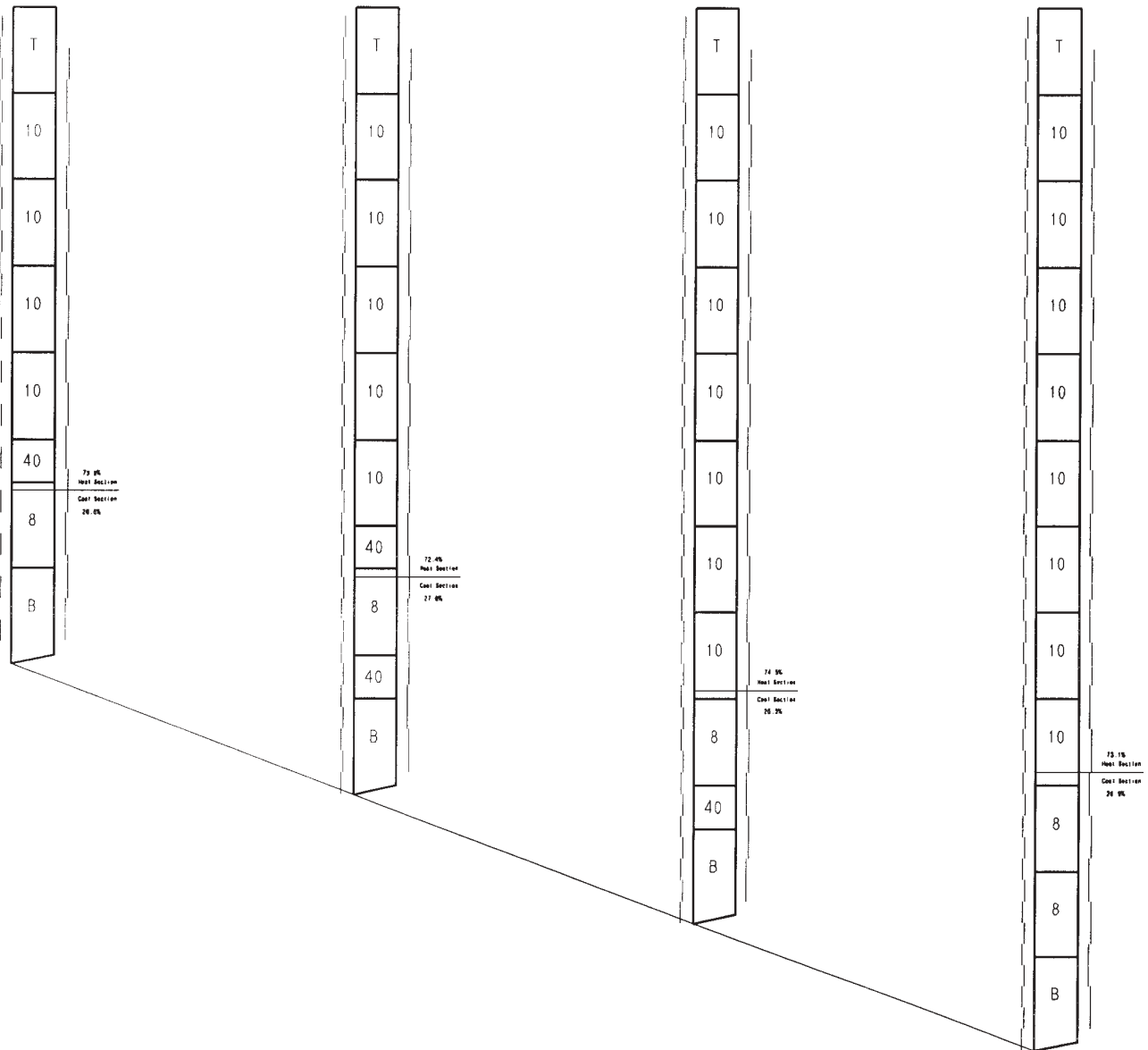

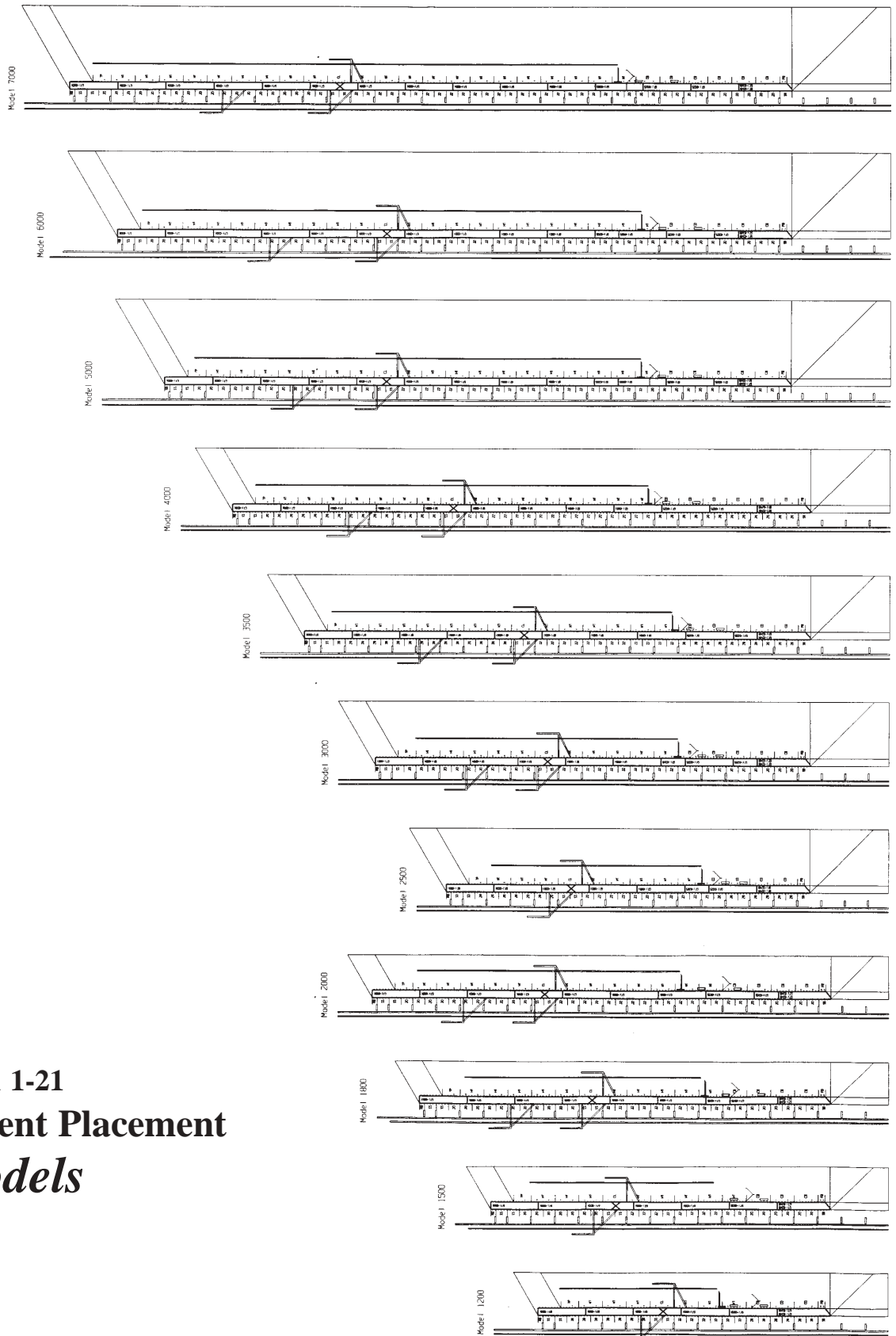
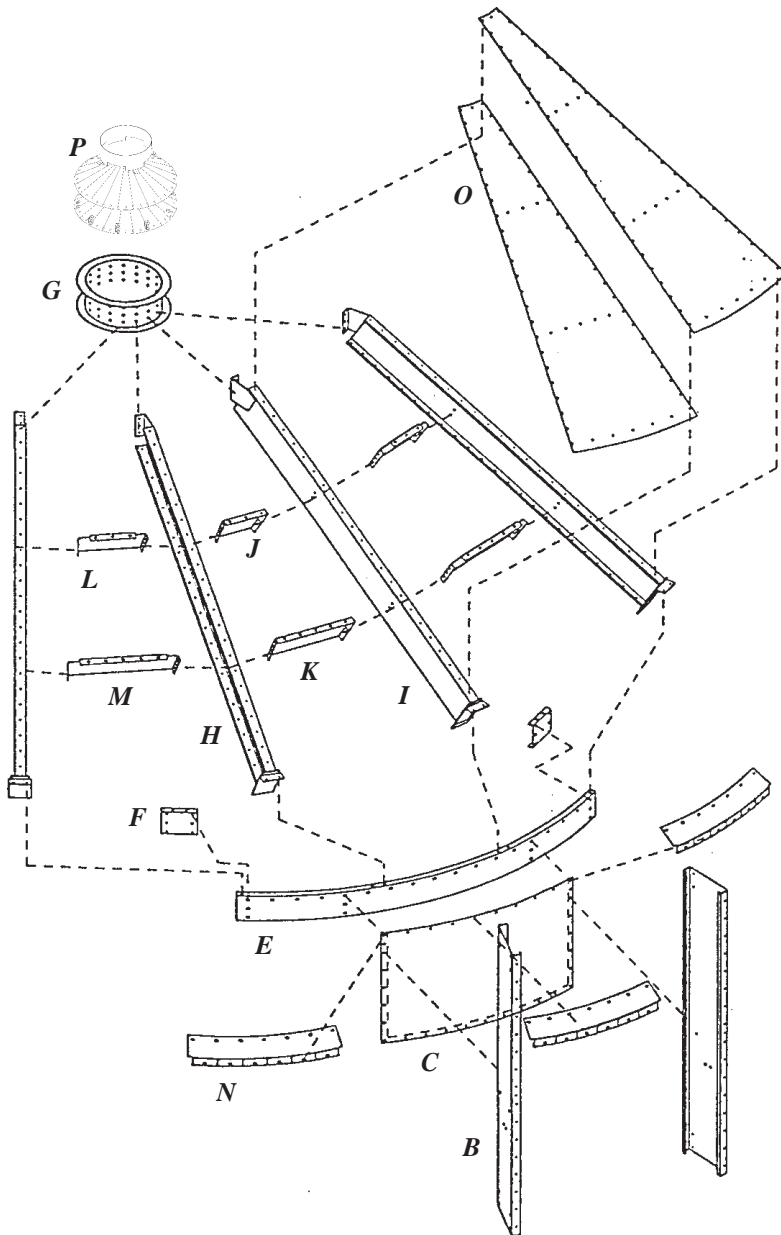

Illustration 1-21
Component Placement
All Models

Plenum Roof 2

Illustration 2-1

Plenum Roof Components (expanded view)



<i>Parts in Order of Installation</i>	<i>Quantity</i>
A. <i>Jig Clips (not shown)</i>	12
B. <i>Vertical Channels</i>	12
C. <i>Inside Top Wall Sheets</i>	12
D. <i>Rolled Plenum Channels (not shown)</i>	6
E. <i>Plenum Eave Channels</i>	6
F. <i>Plenum Eave Channel Splices</i>	6
G. <i>Plenum Roof Center Collar</i>	1
H. <i>Plenum Roof Rafters (RH)</i>	9
I. <i>Plenum Roof Rafters (LH)</i>	9
J. <i>Rafter CrossMember-Short Top</i>	9
K. <i>Rafter CrossMember-Short Bottom</i>	9
L. <i>Rafter CrossMember-Long Top</i>	9
M. <i>Rafter CrossMember-Long Bottom</i>	9
N. <i>Plenum Roof Flashing</i>	18
O. <i>Plenum Roof Sheets</i>	18
P. <i>Peak Cap</i>	1

2 Plenum Roof

18' Tower Dryer Construction

Illustration 2-2

Plenum Roof (aerial view)

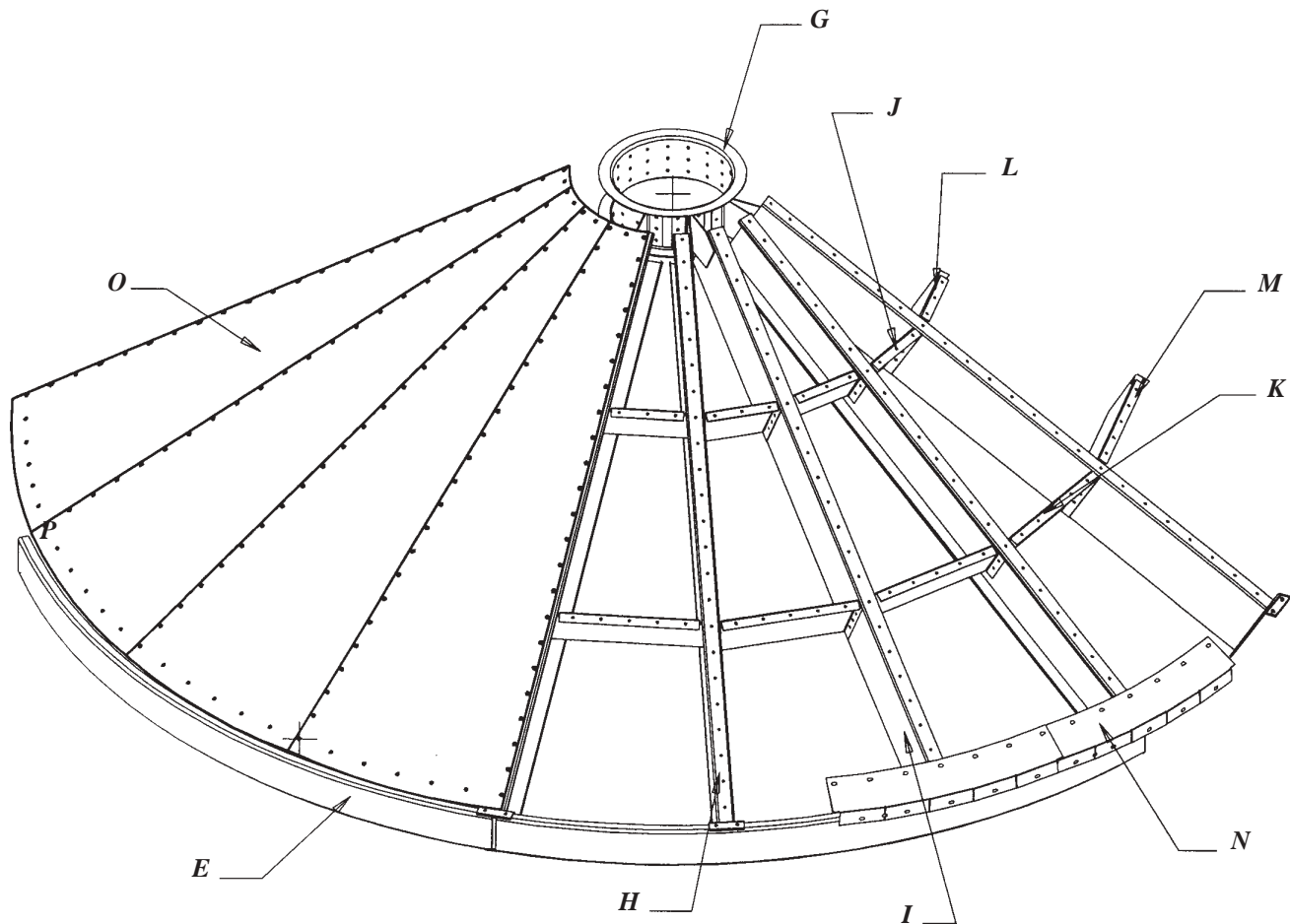

Parts

- E. Plenum Eave Channels
- G. Plenum Roof Center Collar
- H. Plenum Roof Rafters (RH)
- I. Plenum Roof Rafters (LH)
- J. Rafter CrossMember-Short Top
- K. Rafter CrossMember-Short Bottom
- L. Rafter CrossMember-Long Top
- M. Rafter CrossMember-Long Bottom
- N. Plenum Roof Flashing
- O. Plenum Roof Sheets

Note Plenum Eave Channel Splice is not shown.

Illustration 2-3
Plenum Roof (cross section)

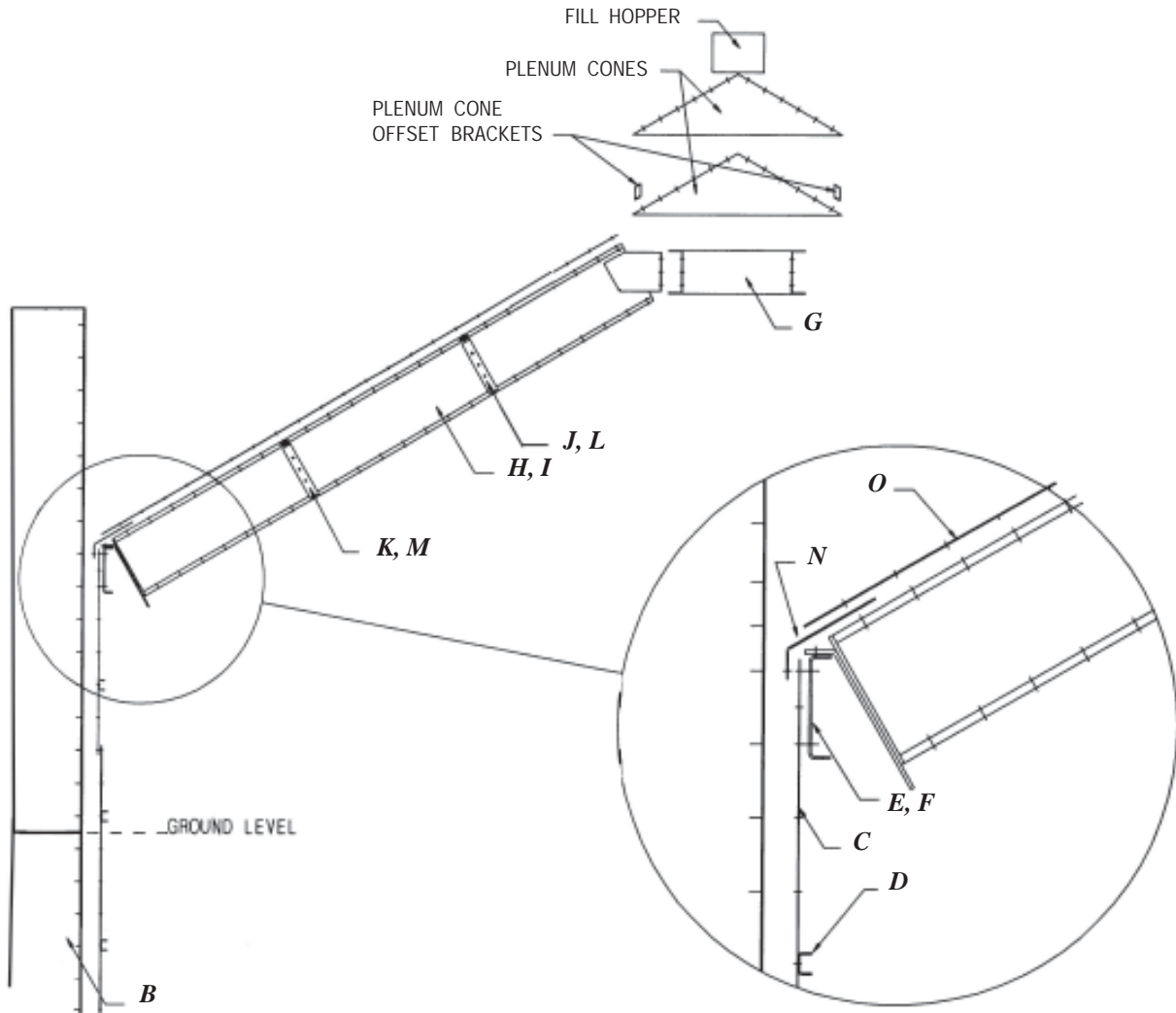

Parts

- B.** Vertical Channels
- C.** Inside Top Wall Sheets
- D.** Rolled Plenum Channels
- E.** Plenum Eave Channels
- F.** Plenum Eave Channel Splices (not shown)
- G.** Plenum Roof Center Collar
- H.** Plenum Roof Rafters (RH)
- I.** Plenum Roof Rafters (LH)
- J.** Rafter CrossMember-Short Top
- K.** Rafter CrossMember-Short Bottom
- L.** Rafter CrossMember-Long Top
- M.** Rafter CrossMember-Long Bottom
- N.** Plenum Roof Flashing
- O.** Plenum Roof Sheets

Illustration 2-4

JigClip and Vertical Channel Placement
All Models

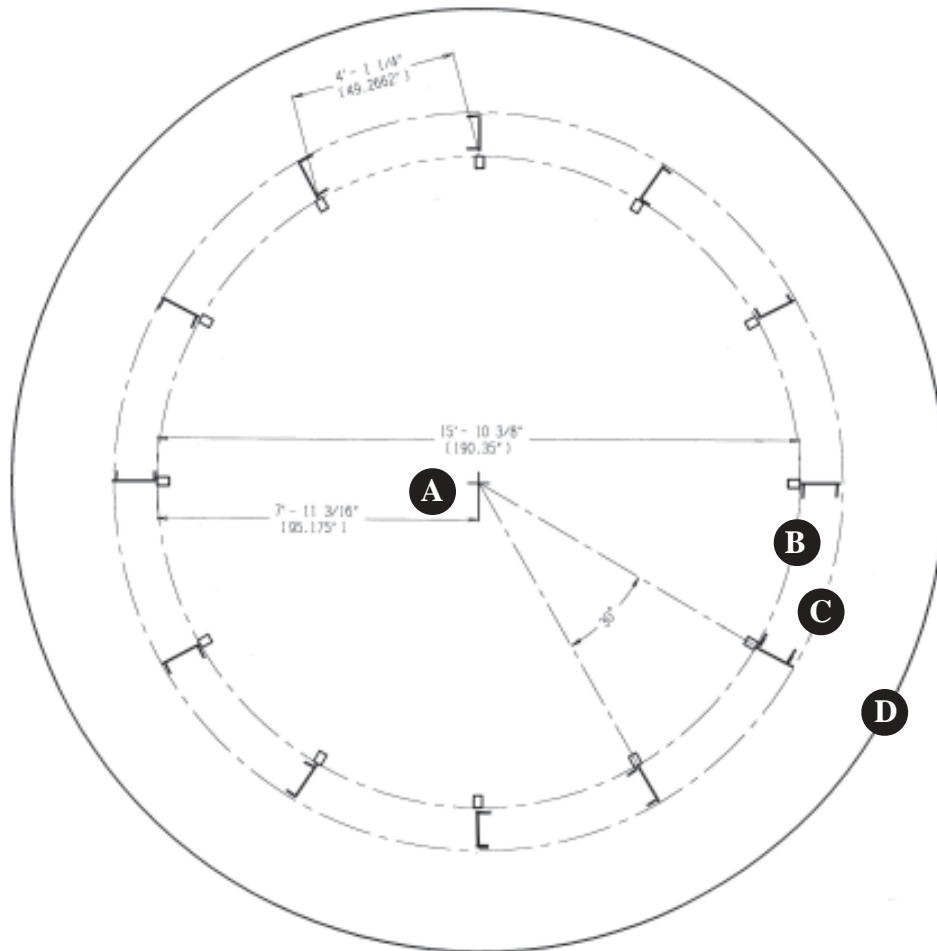

KEY

□ = Jig Clips
install to foundation
at intervals of 4' 1-1/4" around circle A.

[= Vertical Channels are bolted to Jig Clips.

☞ Note orientation of Vertical Channels.
Each Vertical Channel mirrors the
previous one.

A = center of foundation,
(marks center of dryer)

B = circle drawn for Jig Chip installation
radius is 7' 11-3/16"
(marks inside wall of dryer)

C = dryer perimeter
(marks outside wall of dryer)

D = foundation perimeter
minimum required is 23' diameter

**Important Safety Precautions:**

Dryer has sharp edges. These sharp edges may cause serious injury. Use appropriate Personal Protective Equipment. Use proper lifting techniques.



See Chapter 1 “Orientation” for dryer dimensions, components, wall sheet guidelines, etc. See Appendices for “Tools and Equipment”, “Hardware”, etc.

2. STEPS to Construct Plenum Roof

2.1. JIG CLIPS.

Install Jig Clips as follows.



See Illustration 2-4, “Jig Clip and Vertical Channel Placement”.

2.1.1. Mark center of concrete foundation. This will be dryer center.



Be sure foundation is level.



Foundation must be level, with no low or high spots. Jig Clips anchor columns of Vertical Channels to the foundation while the dryer is being constructed. Low or high spots can cause misalignment between Vertical Channels and Wall Sheets causing the Wall Sheets to wrinkle.

2.1.2. Hold a tape measure on dryer center mark with an alignment punch and stretch tape to a radius of 7' 11-3/16”.



Check orientation of dryer to existing equipment, structures, fuel and electric intake. Plan for placement of dryer features per Chapter 1, Orientation.”



Check for lateral clearance.



Check to be sure top of completed dryer will have height clearance.

Use marker, alignment punch, or nail to draw circle on foundation. This is circle B in Illustration 2-4, which is the circle drawn for Jig Clip installation.

2.1.3. Mark the first Jig Clip position on circle B. Be sure that when dryer is complete, grain unload conveyor will center between two Dryer Legs.



When dryer is complete, a dryer leg will buttress under each column of Vertical Channels.

- 2.1.4.** Mark the remaining Jig Clip positions at 4' 1-1/4" intervals around circle drawn for Jig Clip installation.

If last interval is less than, or greater than 4' 1-1/4", split error equally between all intervals. If Jig Clip positions are not accurate, the dryer may not be round, Wall Sheets may be misaligned, and the Divider Hopper between Heat Section and Cool Section may not fit.

- 2.1.5.** Center outside edge of Jig Clip flush with interval mark. Drill foundation through Jig Clip and bolt with 1/2" x 3-3/4" heavy duty expanding anchor bolt and washer. (Photos 2-1 and 2-2)

2.2. VERTICAL CHANNELS.

Bolt 10 gauge Vertical Channel to each Jig Clip. Use 3/8" x 1" bolts. Alternate the direction of each Vertical Channel so that each mirrors the previous one. In other words, bolt Vertical Channels so they are facing [], then opposing [], then facing, and so on around perimeter of dryer.



See Vertical Channel Comparison in Chapter 1, "Orientation".

Photo 2-3 Vertical Channels are facing [].

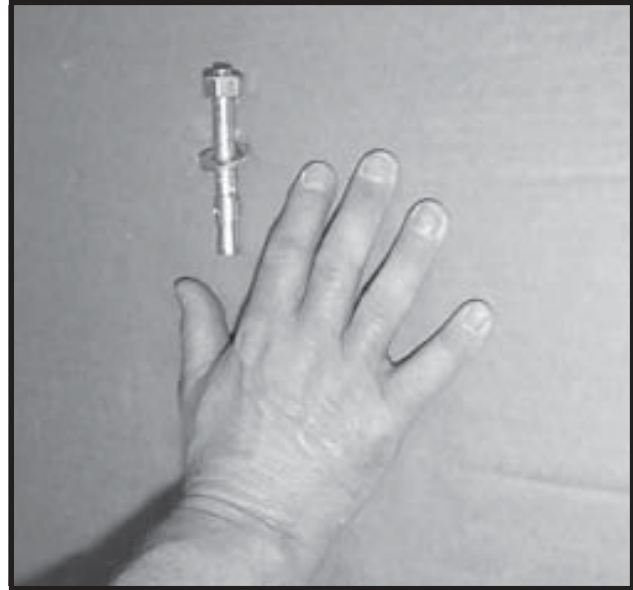

Photo 2-1 1/2" x 5-1/2" Expanding anchor bolt and washer.

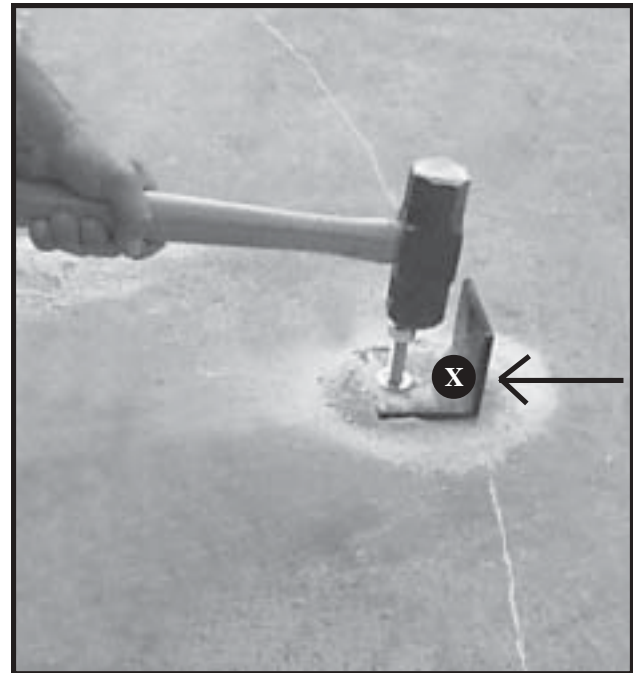

Photo 2-2 Center outside edge of Jig Clip flush with interval mark (under X).

2.3. INSIDE TOP WALL SHEETS.

Install (1) ring of Inside Top Wall Sheets around inside of dryer to form inside Plenum Roof wall as follows.

- 2.3.1.** Use Inside Top Wall Sheets. See Wall Sheet Comparison in Chapter 1, “Orientation” to identify correct Wall Sheet.
- 2.3.2.** Snug bolt perforated Inside Top Wall Sheets (30” high) to Vertical Channels. (Insert bolt toward inside of dryer so that bolt head is in grain column.)

Start Inside Top Wall Sheets at bolt hole #3 (BH3 from bottom of Vertical Channel) but do not fill BH3 because it will be used to install next row of sheets.

Do not fill BH5 from bottom of Vertical Channel. This is where Rolled Plenum Channel will be installed.

Do not fill 3 closely spaced bolts holes higher up on Vertical Channel. This is where Eave Channel will be installed.



Do not tighten bolts yet. (Tighten after Rolled Plenum Channels are installed.)

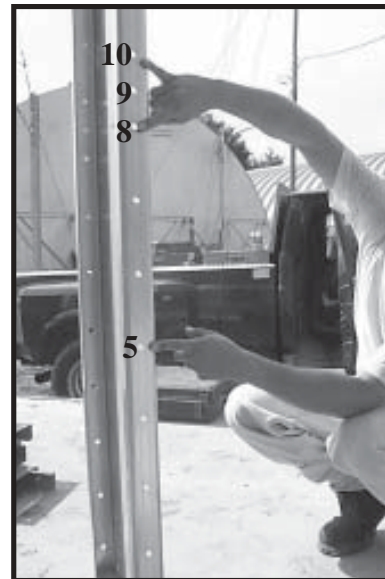

Photo 2-4 Do not fill bolt hole 5 (from bottom of Vertical Channel.) and 3 closely spaced bolts holes above, BH8, BH9, & BH10.



Photo 2-5



Photo 2-6

2.4. ROLLED PLENUM CHANNELS.

Install one ring of Rolled Plenum Channels to reinforce the ring of Inside Top Wall Sheets as follows.

- 2.4.1. Bolt (1) Plenum Channel Splice to each Rolled Plenum Channel with 5/16" x 1" whiz bolt and nut before installing to dryer.



- 2.4.2. Snug bolt Rolled Plenum Channels to Inside Top Wall Sheets with 5/16" x 3/4" whiz lock bolts and nuts.



Bolt in 5th bolt hole from bottom of Vertical Channel.



If necessary to fit last Rolled Plenum Channel into ring, remove bolts from Wall Sheets on both sides, pull one bolt out of Vertical Channel (above or below), bend and push it down into place.

- 2.4.3. Test fit. Install rings of Rolled Plenum Channels to Wall Sheets so closely that fingers will not fit between them.



Photo 2-7
Plenum Channel Splice.

Throughout Dryer

Install Rings of Rolled Plenum Channels to Wall Sheets so closely that fingers will not fit between them.



Photo 2-8 Plenum Channel Splices - as shipped.

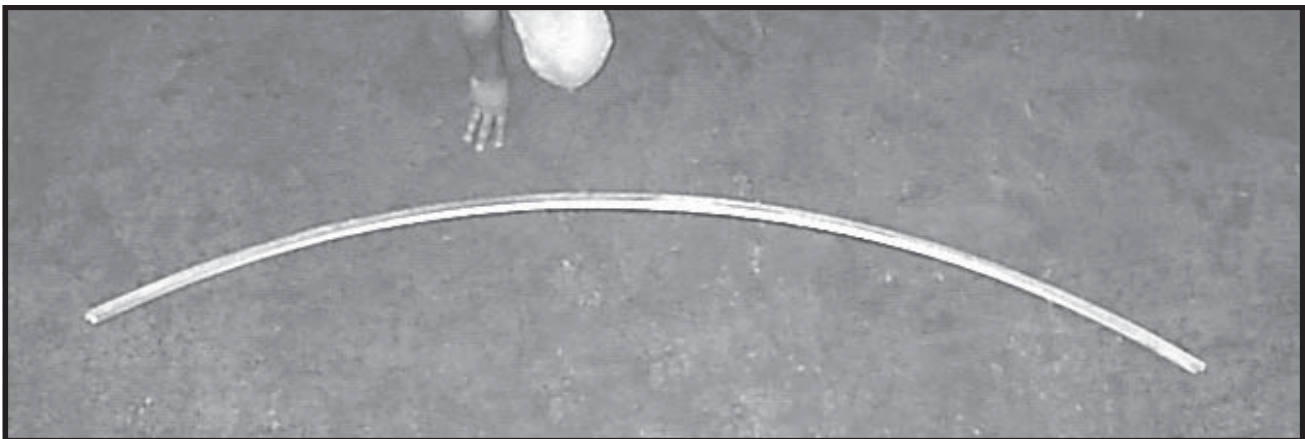

Photo 2-9 Rolled Plenum Channel.

2.4.4. After entire ring of Rolled Plenum Channels is installed to this section of the dryer, tighten bolts.



Photo 2-10 Installing Rolled Plenum Channel to Inside Top Wall Sheets.

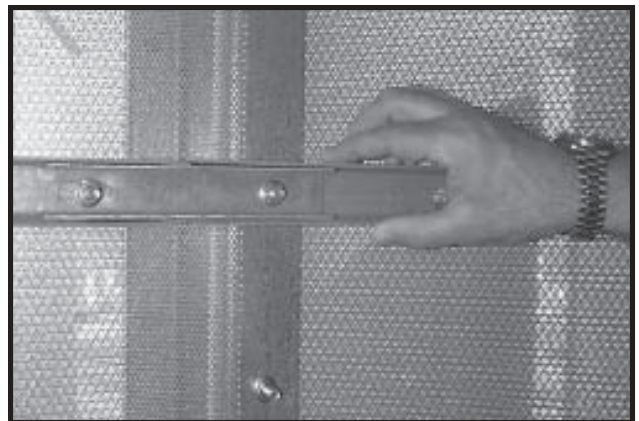

Photo 2-11 Plenum Channel Splice installed.



Photo 2-12 C-Clamp and Alignment Punches (5/8" & larger).

2.5. PLENUM EAVE CHANNELS & PLENUM EAVE CHANNEL SPLICES.



Snug bolt Plenum Eave Channels to Vertical Channels with two 3/8" x 2" grade 8 hex head bolts and nuts per Vertical Channel. Insert bolts in two bottom bolt holes of three bolt holes that are spaced closely together. (Plenum Roof Flashing will be installed in top bolt hole.)

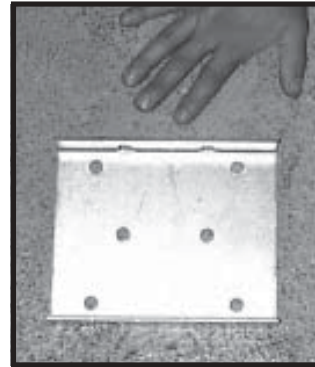

Photo 2-13 Plenum Eave Channel Splice.



Photo 2-14 Splicing Plenum Eave Channels.



Splice Plenum Eave Channels together with Plenum Eave Channel Splices. Use 3/8" x 2" grade 8 hex head bolts and nuts. Plenum Eave Channel Splice is installed on inside of dryer. Insert bolts toward center of dryer, through Wall Sheet, Plenum Eave Channel, and then Plenum Eave Channel Splice.



Photo 2-15 Plenum Eave Channels as shipped.

Tighten ring of Plenum Eave Channels after it is complete.



Photo 2-16 Installing Eave Channels to Vertical Channels.

2.6. PLENUM ROOF RAFTERS (Right Hand & Left Hand) and PLENUM ROOF CENTER COLLAR.

Install (18 RH and LH) Plenum Roof Rafters around roof of dryer as follows. See Illustrations 2-1, 2-2, and 2-3. See Photos 2-17 to 2-28.

2.6.1. From opposite sides of dryer, bring a pair of Plenum Roof Rafters together to Plenum Roof Center Collar in center of dryer. Orient to bolt holes in Plenum Roof Center Collar as shown in Illustration 2-7.

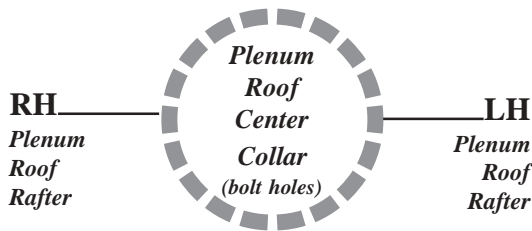

Illustration 2-7

Snug bolt tops of Plenum Roof Rafters to Plenum Roof Center Collar. Use 3/8" x 1" hex head galvanized bolts and nuts.

Snug bolt bottoms of Plenum Roof Rafters in pairs of bolt holes along top of Eave Channel. Use 3/8" x 2" grade 8 hex head bolts and nuts.

2.6.2. Snug bolt two more Plenum Roof Rafters to Plenum Roof Center Collar. Orient to bolt holes in Plenum Roof Center Collar as shown in Illustration 2-8.

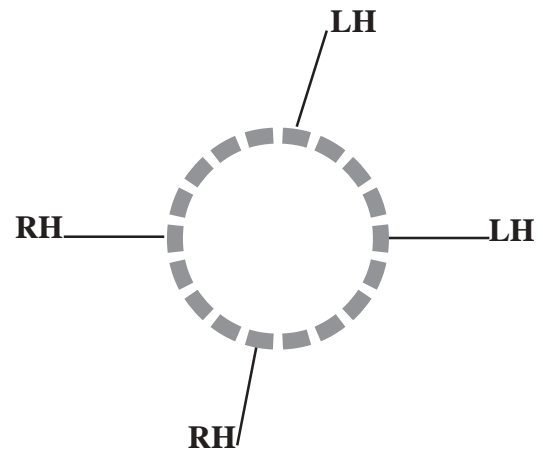

Illustration 2-8

2.6.3. Install remaining (16) Plenum Roof Rafters to Plenum Roof Center Collar as shown in Illustration 2-9.

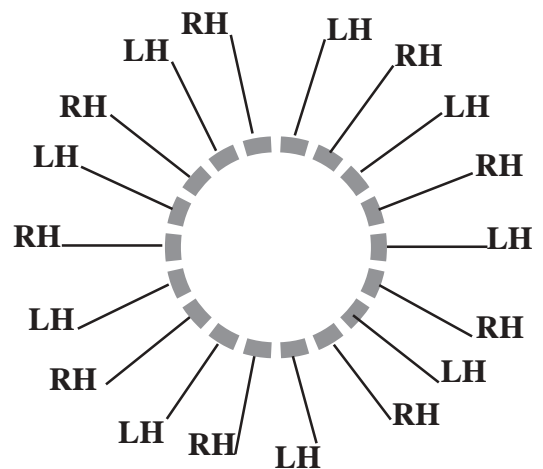

Illustration 2-9

2.6.4. Level Plenum Roof Center Collar, then tighten bolts in Plenum Roof Rafters.



Photo 2-17 Plenum Roof Center Collar.

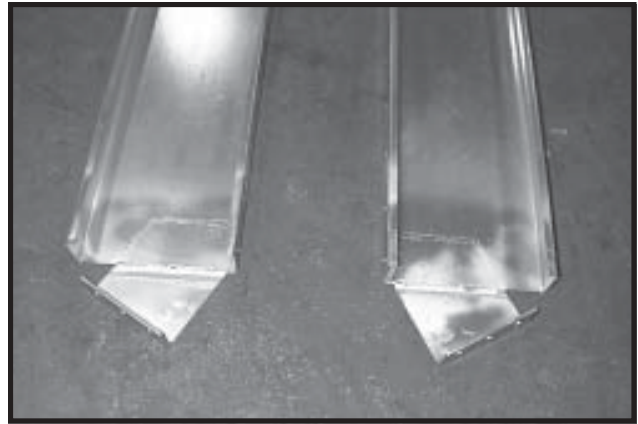

Photo 2-19 Top of Plenum Roof Rafters installs to Center Collar.

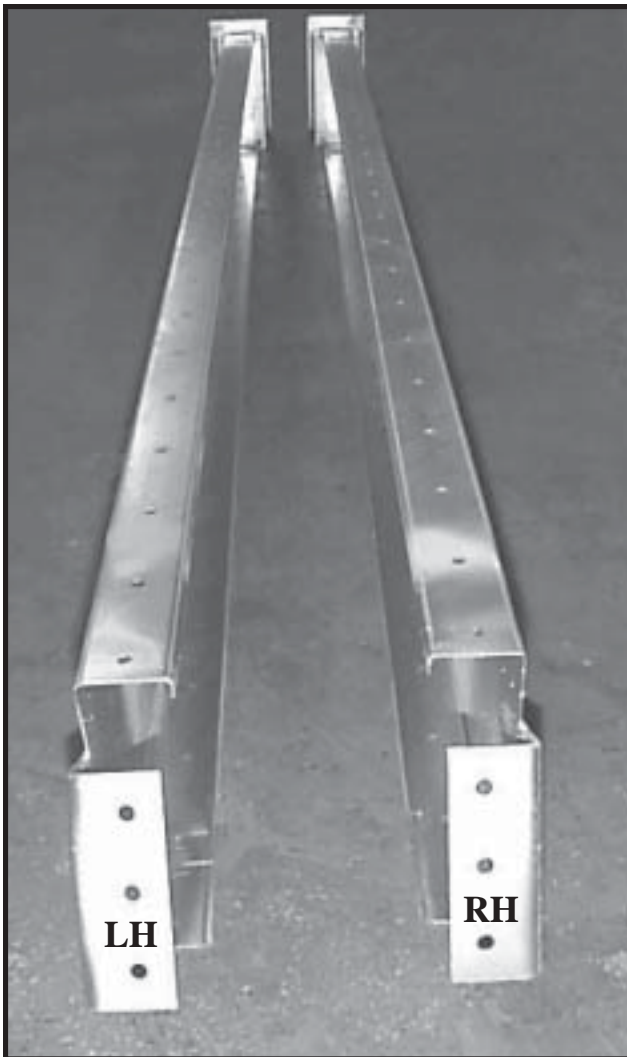

Photo 2-18 A pair of Plenum Roof Rafter are Right Hand and Left Hand. RH and LH mirror each other.



Photo 2-20 Bottom of Plenum Roof Rafters installs to Eave Channel.



Photo 2-21 From opposite sides of dryer, bring a (RH and LH) pair of Plenum Roof Rafters together in center of dryer.



Photo 2-24 Close Up - Bolt top of Plenum Roof Rafters to Plenum Roof Center Collar.



Photo 2-22 Bring first pair of Plenum Roof Rafters together to Plenum Roof Center Collar in center of dryer



Photo 2-25 Close Up - Bolt bottom of Plenum Roof Rafters to top of Plenum Roof Eave Channel (in pairs of bolt holes).



Photo 2-23 Bolt first pair of Plenum Roof Rafters to Plenum Roof Center Collar in center of dryer.

- 2.7. RAFTER CROSSMEMBERS.**
Install Rafter CrossMembers between Plenum Roof Rafters as illustrated in Photos 2-27 to 2-29)



Snug bolt with 5/16" x 1" hex head bolts and nuts until all are installed, then tighten.

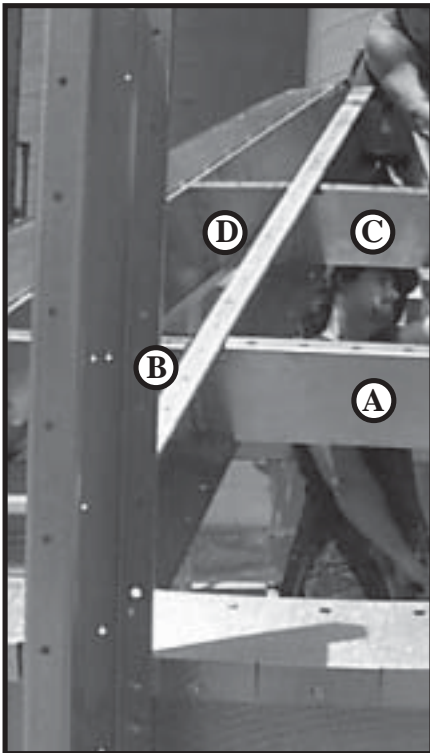

Photo 2-26 Install Rafter CrossMembers as marked.



Photo 2-28 Installing Rafter CrossMembers.

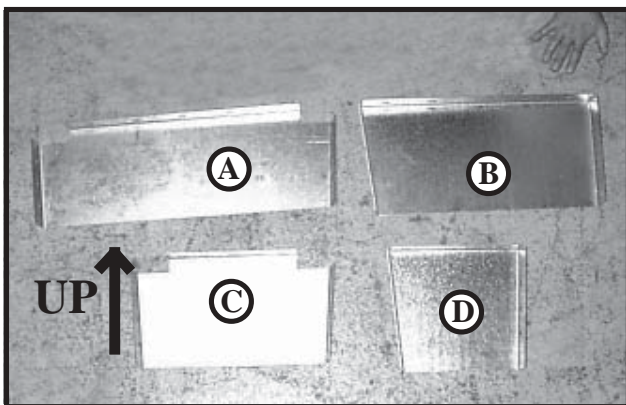

Photo 2-27 Facing dryer from the outside, install Rafter CrossMembers as shown.

- A. Rafter CrossMember - Long Bottom
- B. Rafter CrossMember - Short Bottom
- C. Rafter CrossMember - Long Top
- D. Rafter CrossMember - Short Top

2.8. PLENUM ROOF FLASHING.
Install Plenum Roof Flashing (with tabs down) over Inside Top Plenum Wall Sheets.

Overlap Plenum Roof Flashing.



Snug bolt with 5/16" x 1 whiz bolts and nuts.

Do not tighten bolts in tabs on Flashing until after Plenum Roof Sheets are installed.



Photo 2-29 Installing Plenum Roof Flashing with tabs over Inside Top Wall Sheets.

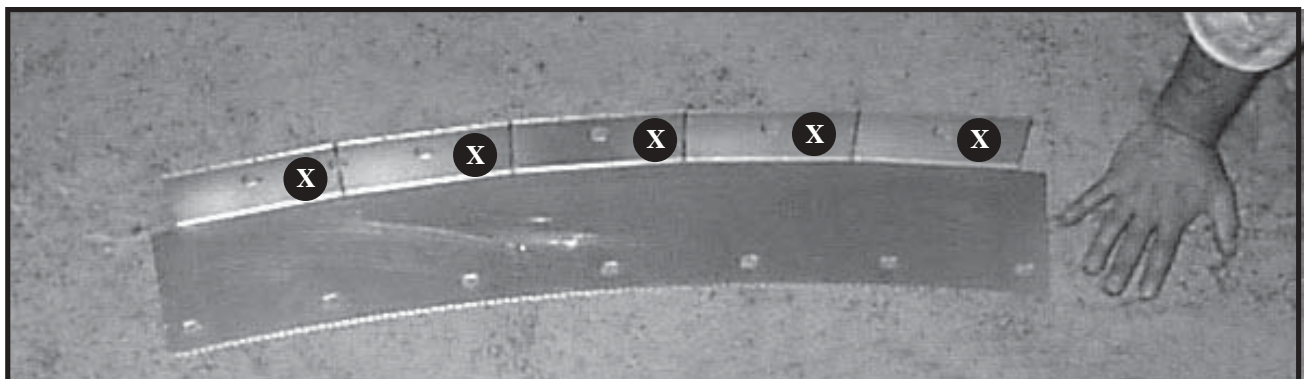

Photo 2-30 Tabs on Plenum Roof Flashing are marked by "X".

- 2.9. PLENUM ROOF SHEETS.**
Bolt Plenum Roof Sheets over Plenum Roof Rafters and over Plenum Roof Flashing as follows.



Use 5/16" x 1" Whiz Lock galvanized bolts and nuts.

Insert bolts toward inside of dryer.



Leave two outside bolt holes on peak of Plenum Roof Sheets open. Peak Cap will be installed there.

(Photo x-x)

Overlap Plenum Roof Sheets so that each sheet overlaps previous sheet with common bolts. In other words, if working counter-clockwise, left edge of each sheet goes over right edge of previous sheet.

When all Plenum Roof Sheets are in place, tighten bolts. Also tighten bolts on tabs of Plenum Roof Flashing.



Photo 2-31 Bolting Plenum Roof Sheets.

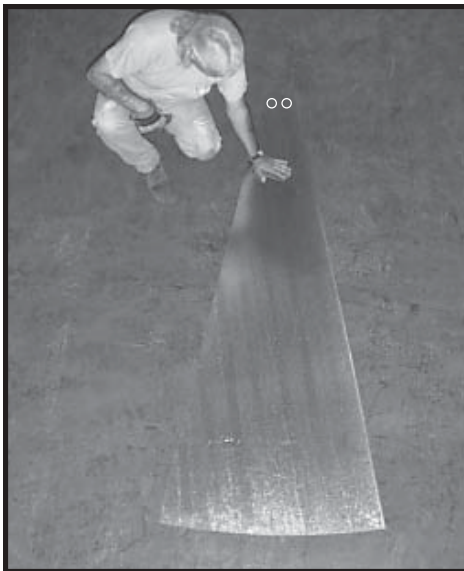

Photo 2-32 Plenum Roof Sheet.

Do not fill top two outside bolt holes on Plenum Roof Sheets (circled) until Peak Cap installation.



Photo 2-33 Aligning Plenum Roof Sheets.



Photo 2-34 Plenum Roof is ready for Peak Cap Assembly installation.

2.10. PEAK CAP & PLENUM ROOF CENTER COLLAR.

2.10.1. Bolt Plenum Cone Fill Hopper over Plenum Center Cone with (9) Plenum Cone Offset Brackets.



Use 5/16" x 1" Whiz Lock galvanized bolts and nuts.

2.10.2. Center and level Peak Cap over Plenum Roof Center Collar.

2.10.3. Bolt Peak Cap to top of Plenum Roof Sheets.



Use 5/16" x 1" Whiz Lock galvanized bolts and nuts in (2) bolt holes on outside of Plenum Roof Sheets.



Photo 2-36 Installing Peak Cap to Plenum Roof Sheets.

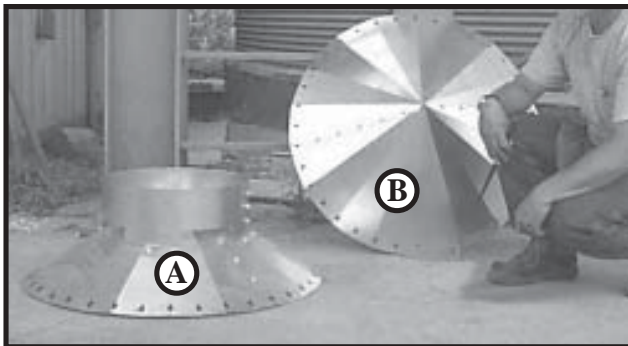

Photo 2-35 PEAK CAP components.

A. Plenum Cone with Fill Hopper

B. Plenum Center Cone

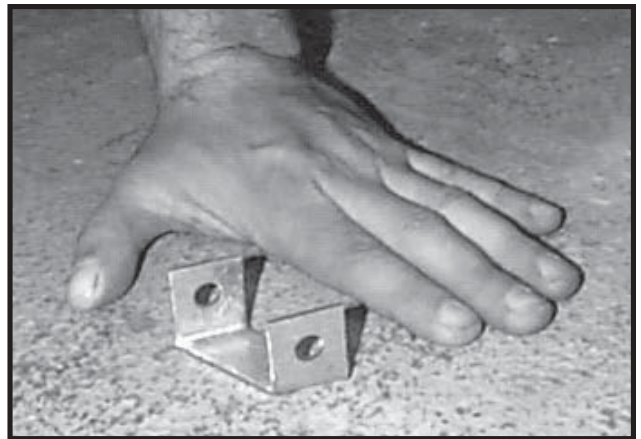

Photo 2-37 Close Up - Plenum Cone Offset Bracket.

2.11. Tighten remaining bolts on Plenum Roof.



Photo 2-38 Tightening Inside Top Wall Sheets.



Photo 2-39 Hand tightening Plenum Roof Rafters.



Photo 2-40 Hand tightening Rafter CrossMembers.

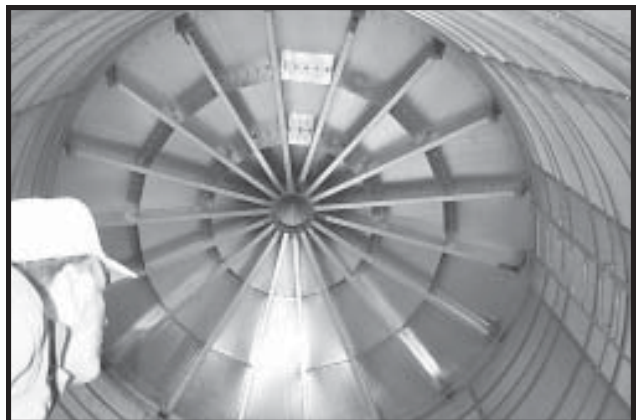
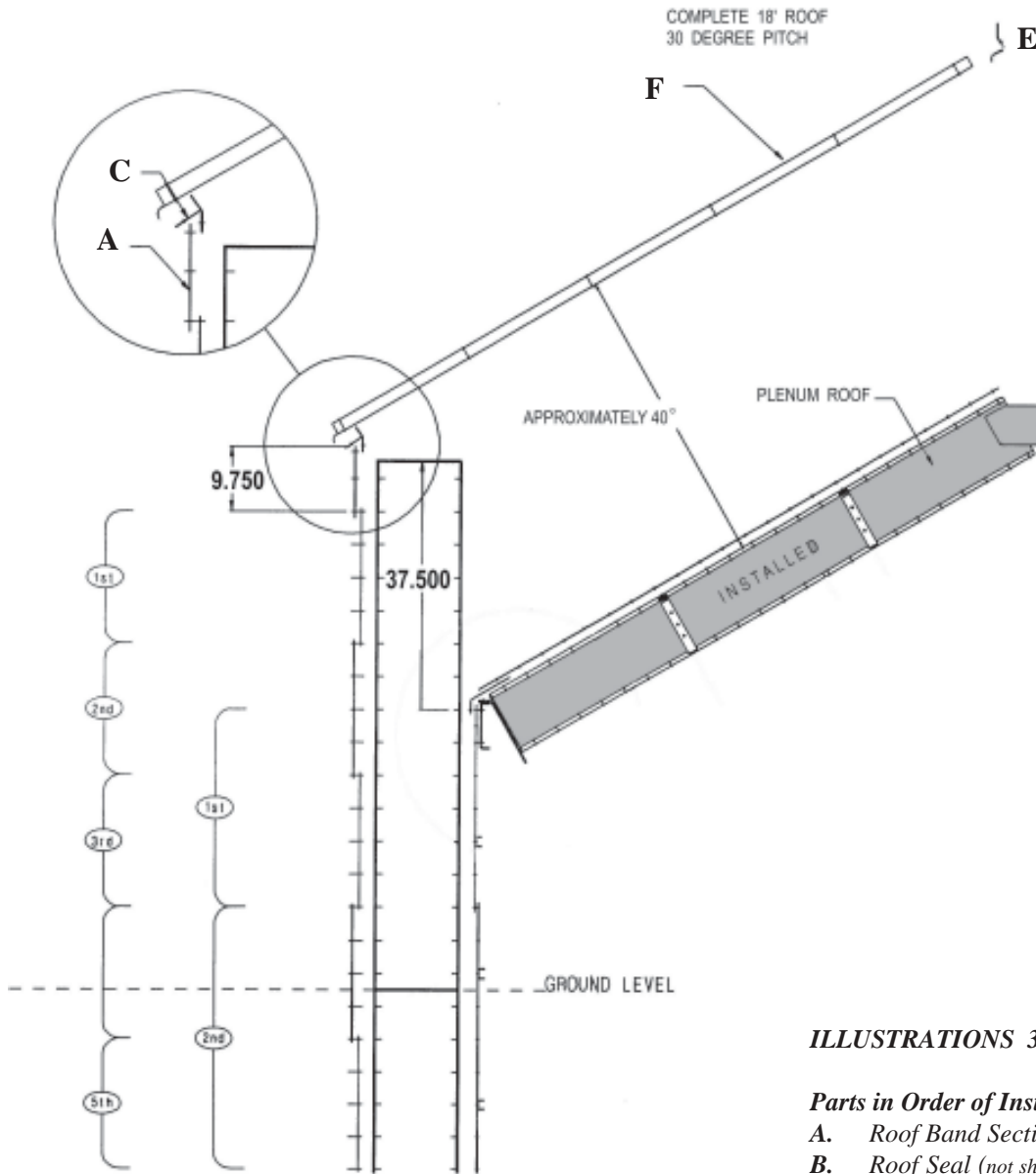

Photo 3-41 Interior view after lifting dryer - Completed Plenum Roof.

Tower Roof 3

Illustration 3-1
Tower Roof (assembled over Plenum Roof - cross section)



ILLUSTRATIONS 3-1 & 3-2

<i>Parts in Order of Installation</i>	<i>Quantity</i>
A. Roof Band Sections	6
B. Roof Seal (not shown)	75'
C. Eave Clips	18
D. Intermediate Eave Clips	18
E. Tower Roof Center Collar Sections	3
F. Tower Roof Sheets	18
G. Roof Rungs	13
H. Expansion Ring Clips (not shown)	18
I. Expansion Ring Sections (not shown)	3
J. Strip Caulking (not shown)	48'
K. Center Collar Flashing Sections	3
L. Fill Tube Weldment	1

3 Tower Roof

18' Tower Dryer Construction

Illustration 3-2
Tower Roof (aerial view)

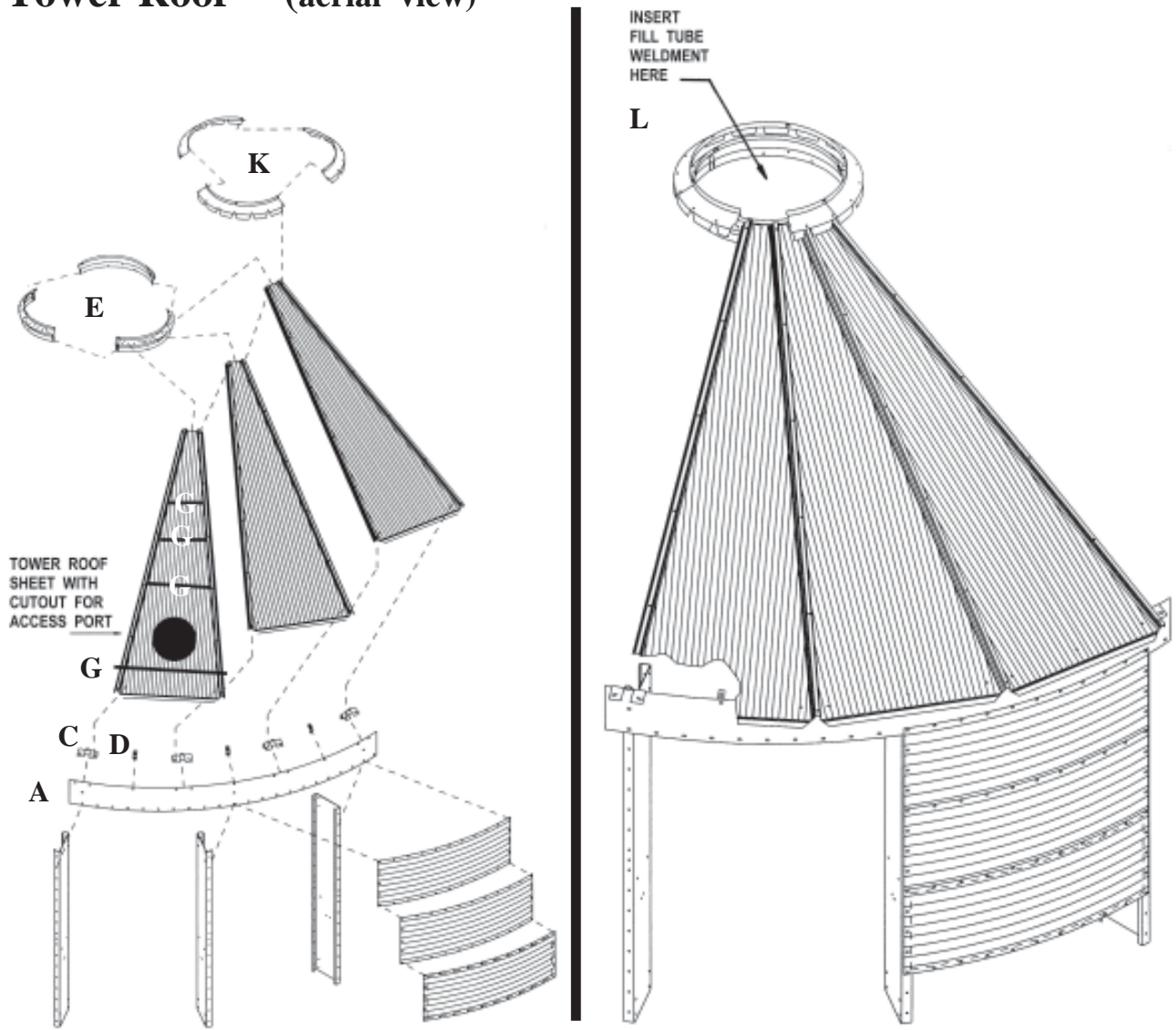

ILLUSTRATIONS 3-1 & 3-2

<i>Parts in Order of Installation</i>	<i>Quantity</i>
A. Roof Band Sections	6
B. Roof Seal (not shown)	75'
C. Eave Clips	18
D. Intermediate Eave Clips	18
E. Tower Roof Center Collar Sections	3
F. Tower Roof Sheets	18
G. Roof Rungs	13
H. Expansion Ring Clips (not shown)	18
I. Expansion Ring Sections (not shown)	3
J. Strip Caulking (not shown)	48'
K. Center Collar Flashing Sections	3
L. Fill Tube Weldment	1

Illustration 3-3 Tower Roof Access Port

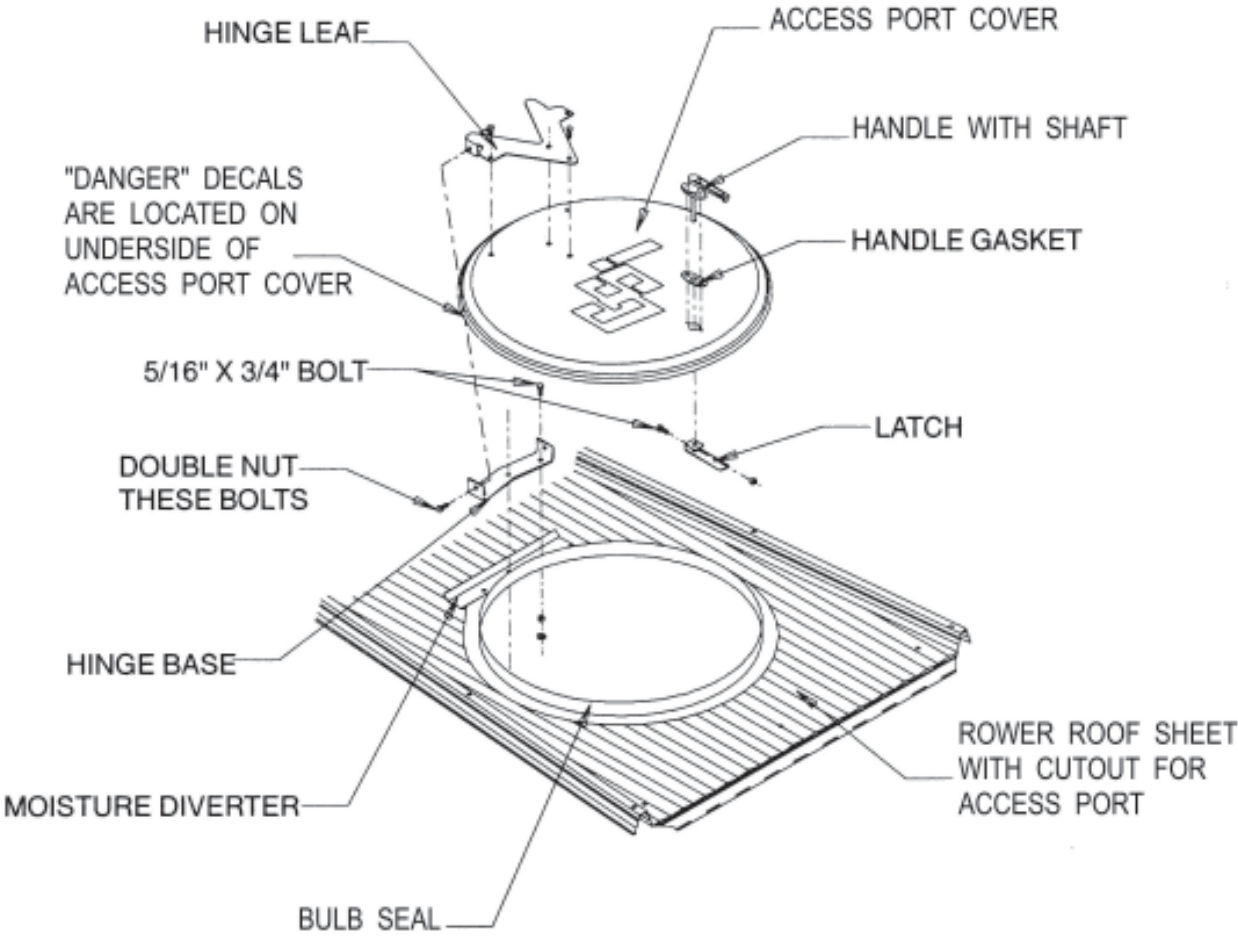

**Important Safety Precautions:**

Dryer has sharp edges. These sharp edges may cause serious injury. Use appropriate Personal Protective Equipment. Use proper lifting techniques.



See Chapter 1 “Orientation” for dryer dimensions, components, wall sheet guidelines, etc.
See Appendices for “Tools and Equipment”, “Hardware”, etc.

3. STEPS to Construct Tower Roof

3.1. Roof Band.



Use 5/16” x 3/4” Stainless Steel Whiz Lock Bolts and 5/16” Nuts.

Install Roof Band sections so they overlap around outside of dryer. Bolt each Roof Band section across three Vertical Channels, in top two bolt holes of each Vertical Channel.

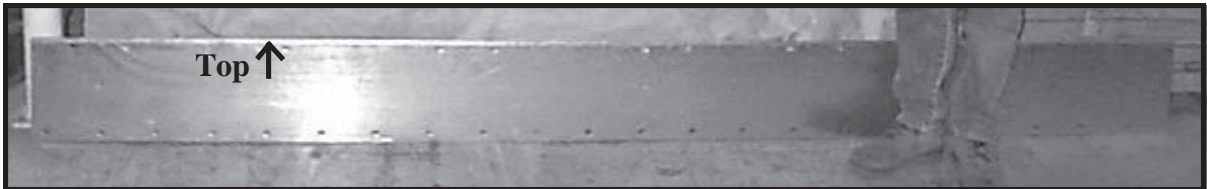

Photo 3-1 Roof Band Section. Top of Roof Band has pairs of bolt holes alternating with single bolt holes. Bottom of Roof Band has evenly spaced bolt holes.

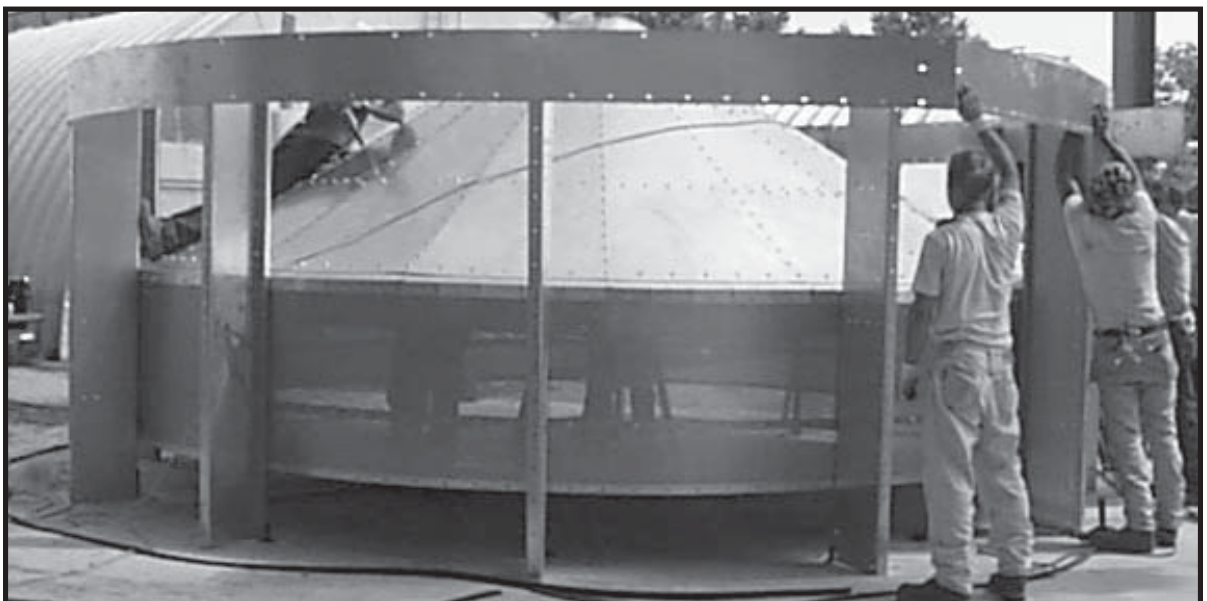

Photo 3-2 Installing Roof Band Sections to overlap around (outside) top of Vertical Channels.

3.2. Bulb Seal.

Press continuous strip of Bulb Seal over top of entire length of Roof Band.

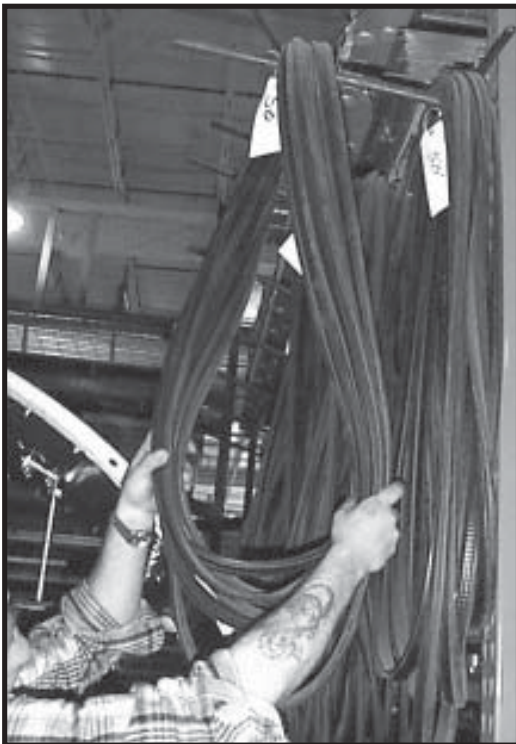



Photo 3-3 Bulb Seal as shipped.



Photo 3-4 Pressing Bulb Seal over top of Roof Band.

3.3. Eave Clip.

 Use 5/16" x 3/4" Stainless Steel Whiz Lock Bolts and 5/16" Nuts.

Snug bolt tabs of Eave Clips (over Roof Seal) to outside of Roof Band. Use pairs of bolt holes at top of Roof Band.

 Do not tighten bolts until after Expansion Ring is loosely installed to Tower Roof.

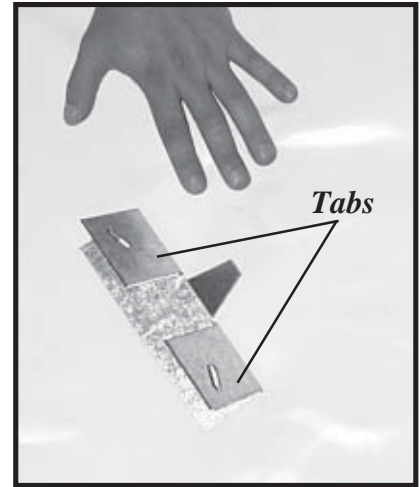



Photo 3-6 Eave Clip.

3.4. Intermediate Eave Clip.

See Illustrations 3-1, 3-2, & 3-3.

 Use 5/16" x 3/4" Stainless Steel Whiz Lock Bolts and Nuts.

Snug bolt Intermediate Eave Clips to inside of Roof Band. Use single holes at top of Roof Band.

 Do not tighten bolts until after Expansion Ring is loosely installed to Tower Roof.



Photo 3-7 Intermediate Eave Clip.



Photo 3-5 Installing Bulb Seal, Eave Clips, and Intermediate Eave Clips to Roof Band.



Photo3-8 Installing Eave Clip and Intermediate Eave Clips.

Tower Roof Hardware.



Photo 3-9

- (A) Bin Bolt, 5/16" x 3/4", grade 5 with neoprene washer
- (B) Hex Head Nut, 5/16", grade 2
- (C) Bin Bolt, 5/16" x 1-1/4", grade 5 with neoprene washer



Photo 3-10 Close Up - neoprene washers.

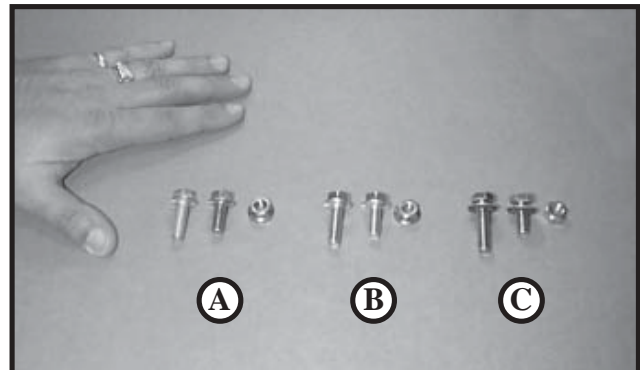



Photo 3-11 Comparison of 5/16" hardware.

- (A) Stainless Steel, Whiz Lock
 - Bolts = dull gray
 - Nuts = shiny gray (with flange)
- (B) Galvanized, Whiz Lock
 - Bolts = shiny gray
 - Nuts = yellow (with flange)
- (C) Bin, Hex Head
 - Bolts = yellow (with neoprene washers)
 - Nuts = yellow (no flange)

3.5. Tower Roof Center Collar.

3.5.1. Bolt (3) Tower Roof Center Collar Sections together.

 Use 5/16" x 3/4" Bin Bolts, grade 5 bolts, 5/16" Hex Head nuts, & Neoprene Washers.

 Insert bolts toward inside of Center Collar, with Neoprene Washers against outside of Center Collar to provide seal.

3.5.2. Position Tower Roof Center Collar above Peak Cap, in center of dryer.



Photo 3-12 Tower Roof Center Collar Section (1 of 3).

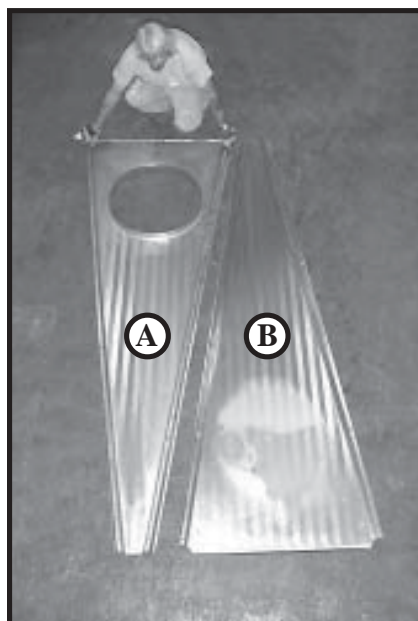



Photo 3-13 (A) Tower Roof Sheet with cutout for Tower Roof Access Port. (B) Tower Roof Sheet.

3.6. Tower Roof Sheets, Tower Roof Rungs, Expansion Ring Clips.

 Install Roof Rungs & Expansion Ring Clips to Tower Roof Sheets during Tower Roof Sheet installation.

Vertical Tower Roof Seams.

Use 5/16" x 1-1/4" Bin Bolts, grade 5 bolts, 5/16" Hex Head nuts, & Neoprene Washers.

Leave out second to top bolt in Tower Roof vertical seams for Center Collar Flashing installation.

Horizontal Tower Roof Seams.

Use 5/16" x 3/4" Bin Bolts, grade 5 bolts, 5/16" Hex Head nuts, & Neoprene Washers.

All Tower Roof Seams. Insert bolts toward inside of dryer, with Neoprene Washers against outside of dryer to provide seal.

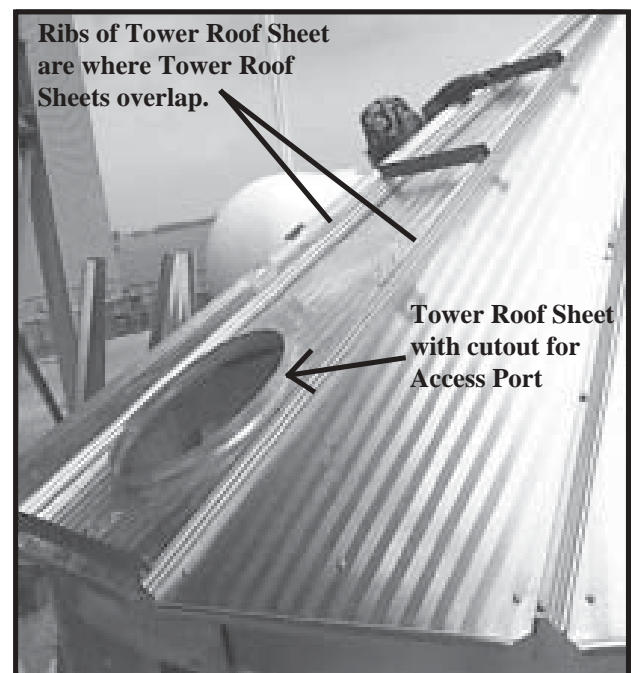

Photo 3-14 Install Roof Rungs on ribs of the Tower Roof Sheet with cutout for Access Port.

3.6. continued



Roof Access Port must be safely accessible from outside tower ladder.

Install Tower Roof Sheet with cutout for Roof Access Port directly above where outside ladder will be installed.

From opposing sides of dryer, bring first pair of Tower Roof Sheets together to Tower Roof Center Collar in center of dryer. Position Tower Roof Sheet with cutout for Roof Access Port directly above where Outside Ladder will be installed.

Snug bolt top bolt hole of Tower Roof Sheets to outside bottom of Tower Roof Center Collar. Snug bolt bottom bolt hole of Tower Roof Sheets to Eave Clips, and Intermediate Eave Clips. Leave other bolt holes on ribs (vertical seams) open.

Bring second pair of Tower Roof Sheets together to Tower Roof Center Collar and snug bolt at top and bottom like first pair.



Check to be sure peak assembly is centered on dryer.

Install remaining Tower Roof Sheets as above, then fill in vertical and horizontal seams. Leave second to top bolt hole open for Center Collar Flashing installation. Completed Tower Roof Sheets will overlap with common bolts in ribs.

Wait to tighten Tower Roof bolts until after Expansion Ring is loosely installed to Tower Roof



Photo 3-15 Bringing two opposing Tower Roof Sheets to Tower Roof Center Collar. Position Tower Roof Sheet with Access Port cutout directly above where outside ladder will be.



Photo 3-16 Inside view - peak of Tower Roof Sheets bolts to bottom of Tower Roof Center Collar.



Photo 3-17 Inside view - Tower Roof Sheets bolt to Eave Clips, and Intermediate Eave Clips.

Install Roof Rungs & Expansion Ring Clips to Tower Roof Sheets during Tower Roof Sheet installation.

Count Bolt Holes (BH) from bottom of rib of Tower Roof Sheet.

- **Set of (4) Roof Rungs - install across Tower Roof Sheet with cutout for Access Port in BH1, BH3, BH4, & BH5.**
- **Remaining Roof Rungs - install across every other Tower Roof Sheet in BH5.**
- **Install Expansion Ring Clips in every BH3.**



Photo 3-18 Bolt Holes (BH) for Tower Roof Rungs and Expansion Ring Clips.

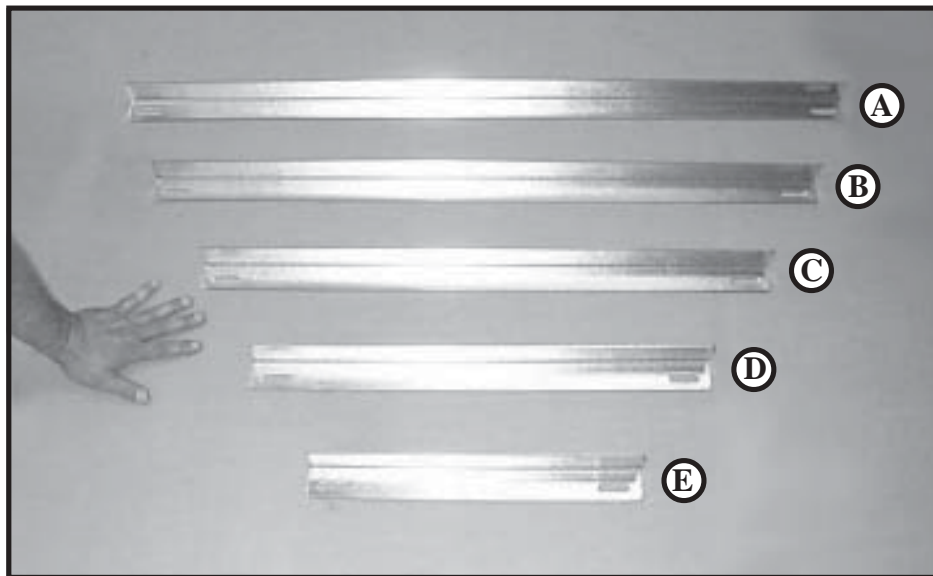

Photo 3-19

	<u>LENGTH</u>	<u>PART</u>	<u>QUANTITY</u>
(A)	41-1/4"	Tower Roof Rung	(1)
(B)	36"	Tower Roof Rung	(1)
(C)	29"	Tower Roof Rung	(1)
(D)	22"	Tower Roof Rung	(9)
(E)	15"	Tower Roof Rung	(1)



Photo 3-20 Expansion Ring Clip (4").

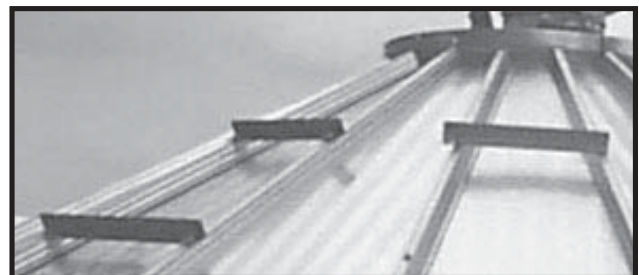

Photo 3-21 Close Up - Roof Rungs installed to ribs of Tower Roof Sheets.

3.7. Expansion Ring.

After Expansion Ring Clips are installed to Tower Roof Sheets, install Expansion Ring Sections as follows.



Use Expansion Ring Hardware. (Photo 3-24) Double nut (spin two nuts closely together) each expansion bolt.



Expansion bolts should be fully contracted during installation. In other words, leave double nuts spun closely together until after Expansion Ring is complete.

3.7.1. Insert first Expansion Ring Section into Expansion Ring Clips.

Double nut an expansion bolt and screw into first Expansion Safety Ring Section.

Insert next Expansion Ring Section into adjoining Expansion Ring Clips. Screw second Expansion Ring Section onto free end of first expansion bolt.

Continue installing Expansion Ring Sections until ring is complete around Tower Roof.

3.7.2. Tighten all Tower Roof bolts, including bolts on Eave Clips and Intermediate Eave Clips.

3.7.3. Tighten expansion bolts between Expansion Ring Sections by spinning double nuts apart. Spin nuts evenly around tower roof until Expansion Ring lifts Tower Roof to show a slight crown.



Photo 3-22 Expansion Ring Sections.

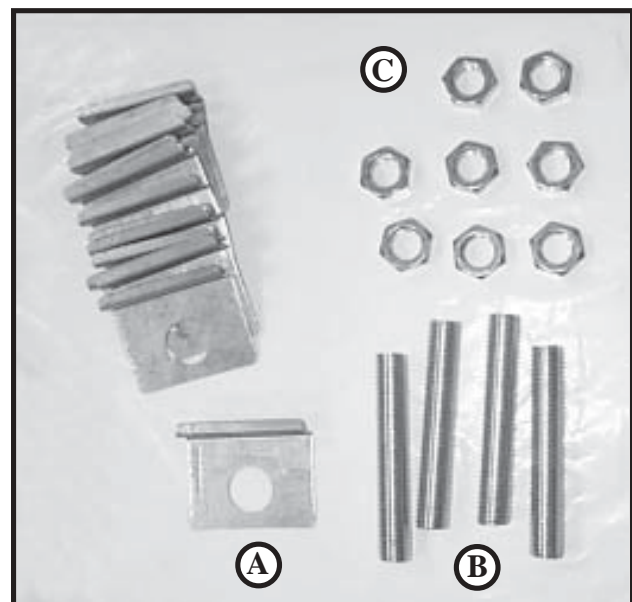

Photo 3-23 Expansion Ring Hardware.

- (A) Expansion Ring Clip (4")
- (B) 1" x 6" (full thread) Expansion Bolts
- (C) 1" Expansion Nuts



Photo 3-24 Installing Expansion Ring to Expansion Ring Clips.



Photo 3-25 Close Up - Installing Expansion Ring & Clips.

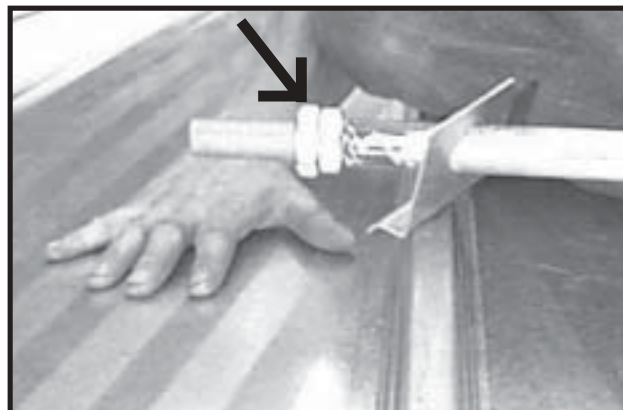

Photo 3-26 Double nut on fully contracted expansion bolt.

3.7. Install (3) Center Collar Flashing sections and caulk as follows.

3.7.1. Wipe oil from outside of Tower Roof Center Collar where Center Collar Flashing Section will join it. Press on Strip Caulking (24' rolls).

3.7.2. Align vertical edge of first Center Collar Flashing Section along a seam of Center Collar. Tabs of Center Collar Flashing will fit over ridges in Tower Roof Sheets.

Bolt using the following hardware.

Center Collar to Flashing Seam.

 Use 5/16" x 3/4" Bin Bolts, grade 5 bolts, 5/16" Hex Head nuts, & Neoprene Washers.

Flashing to Tower Roof Sheet Rib Seam.

 Use 5/16" x 1-1/4" Bin Bolts, grade 5 bolts, 5/16" Hex Head nuts, & Neoprene Washers.

3.7.3. Install (2) remaining Center Collar Flashing Sections in the same way.

 Apply Strip Caulking where Center Collar Flashing sections overlap.

 Insert bolts toward inside of dryer, with Neoprene Washers against outside of dryer to provide seal.

3.8. Fill Tube Weldment.

Insert Fill Tube Weldment into Center Collar.

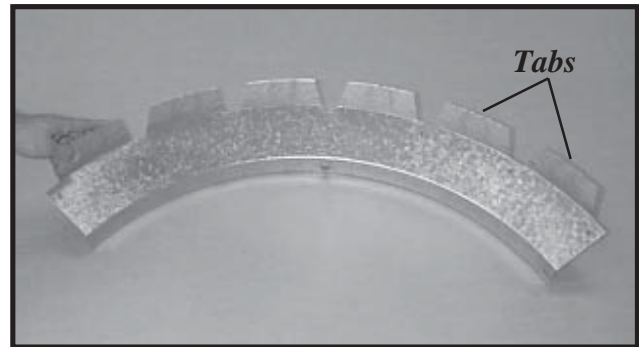

Photo 3-27 Center Collar Flashing Section (1 of 3).

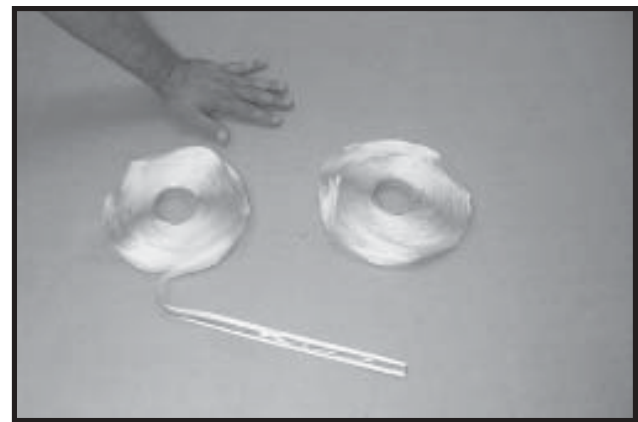

Photo 3-28 Strip Caulking (24' rolls).



Photo 3-29 Tightening Center Collar Flashing bolts.



Photo 3-30 Fill Tube Weldment.

3.9. Access Port Cover.

See Illustration 3-3.

Install Access Port Cover to the Tower Roof Sheet that has a cutout for the Access Port as follows.

3.9.1. Locate where Moisture Diverter will join Access Port Tower Roof Sheet. Wipe area clean of oil and press on Strip Caulking (24' rolls) to cover bolt holes.

3.9.2. With common bolts, bolt Moisture Diverter, then Hinge Base to Access Port Tower Roof Sheet. Use 5/16" x 3/4" Stainless Steel Whiz Lock bolts and nuts.

3.9.3. Use 3/8" x 1" Stainless Steel Whiz Lock bolts and nuts to bolt the following parts.

- Hinge Leaf to Access Port Cover.
- Hinge Leaf to Hinge Base. Use double nut.

3.9.4. Place Handle Gasket under Handle and bolt to Access Port Cover.

Use (2) 10-24 x 5/9" bolts and lock nuts.

Insert Handle shaft toward inside of dryer.

3.9.5. Bolt Latch to shaft of Handle as follows.

- Insert 5/16" x 1-1/4", grade 5 bolt with nut and neoprene washer into Latch.
- Spin nut onto bolt.
- Slide Latch onto shaft of Handle, up or down until it will catch bottom of Tower Roof Sheet.
- Tighten bolt to lock.

3.9.6. Bulb Seal. Press pre-cut Bulb Seal onto rim of Access Port cutout on Tower Roof Sheet.



Photo 3-31 Access Door Cover with "DANGER - Avoid Suffocation" Decals.

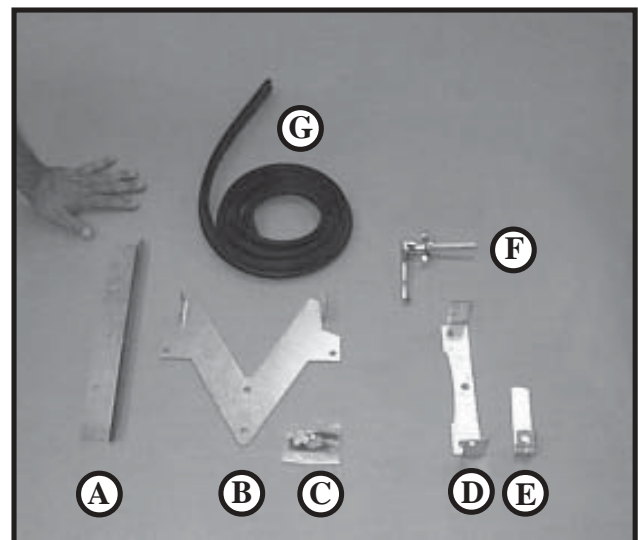

Photo 3-32 Access Port Cover hardware package.

- A. Moisture Diverter
- B. Hinge Leaf
- C. (4) 10-24 x 5/8" bolts and lock nuts, handle gasket.
- D. Hinge Base
- E. Latch
- F. Handle with shaft
- G. Pre-cut Bulb Seal



Photo 3-33 Pressing pre-cut Bulb Seal on rim of Access Port cutout on Tower Roof Sheet.



Photo 3-34 Close Up - Access Port Cover installed.



Photo 3-35 Inside View - Access Port Cover installed.

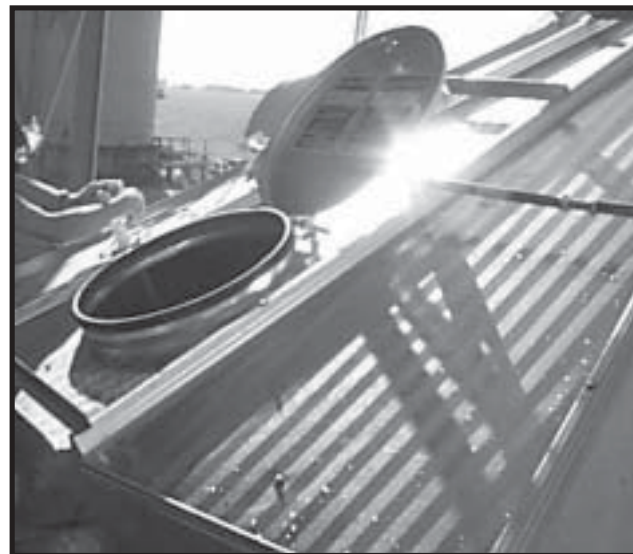



Photo 3-36 Outside View - Access Port Cover installed.

3.10. Outside Wall Sheets.

Install two rows of Solid Outside Wall Sheets (20" high) to Vertical Channels.

-  Use common bolts to install brackets for Outside Ladder with Safety Cage.
(See Chapter 4)

Install Perforated Sheets as required.

See Chapter 1, "Orientation" for illustrations and wall sheet installation guidelines.

Ladder - outside 4

Illustration 4-1

Outside Ladder with Top Safety Cage

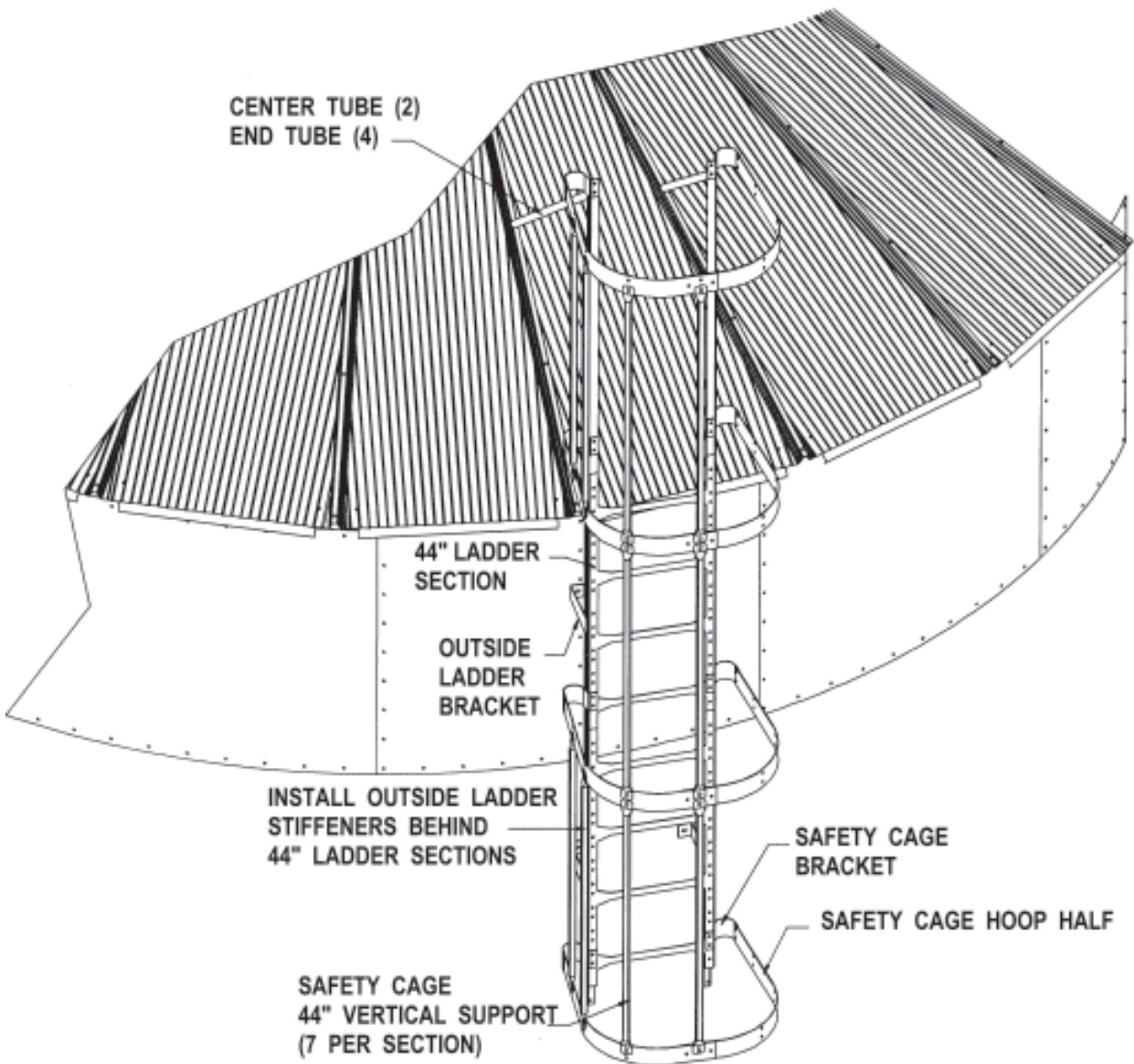

Illustration 4-2

**Outside Ladder with Safety Cage
Runs From Roof of Dryer to
Foundation.**

Top Safety Cage
install at top of dryer.

Safety Cage Extensions
install from Top Safety Cage at top of dryer
to Bell Safety Cage at bottom of dryer.

Bell Safety Cage
install 7' or 8' above foundation

Outside Ladder
install from eave of dryer to foundation.

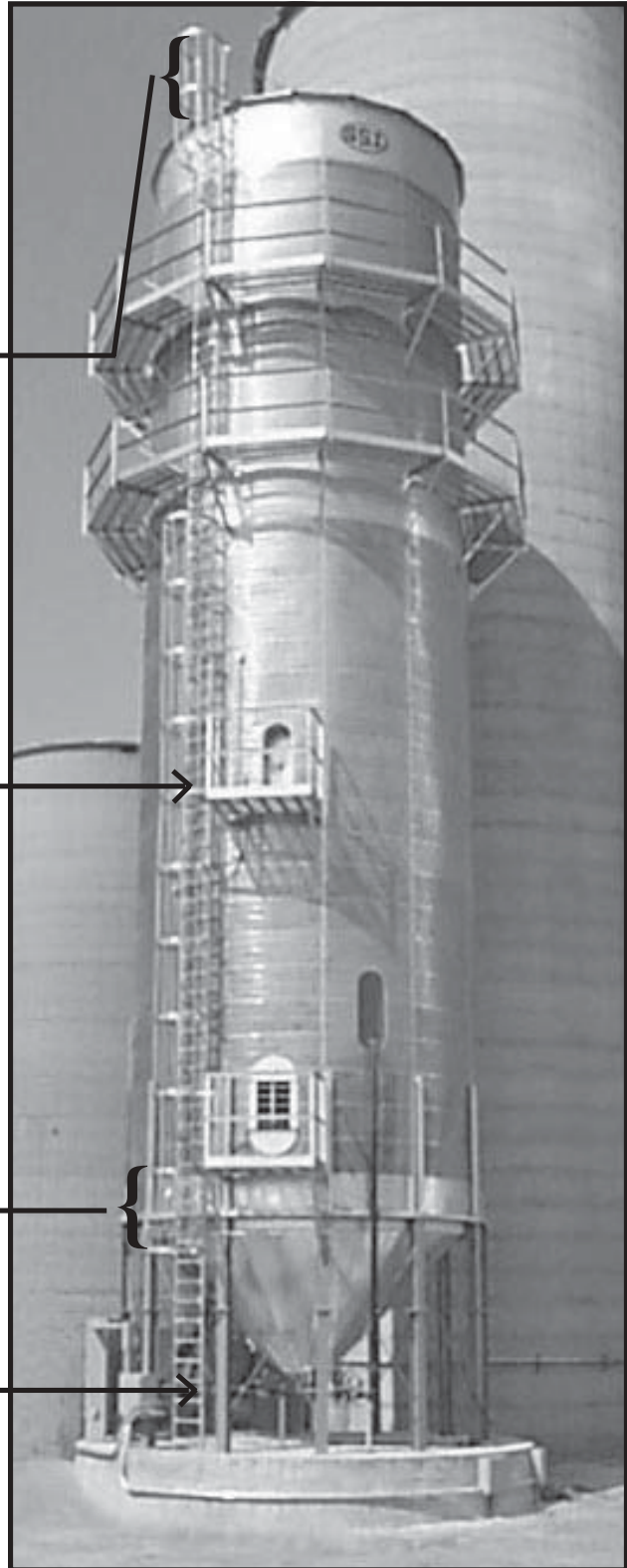

Photo 4-1

**Important Safety Precautions:**

Dryer has sharp edges. These sharp edges may cause serious injury. Use appropriate Personal Protective Equipment. Use proper lifting techniques.



See Chapter 1 “Orientation” for dryer dimensions, components, wall sheet guidelines, etc.
See Appendices for “Tools and Equipment”, “Hardware”, etc.

4. STEPS to Install Outside Ladder with Safety Cage

4.1. Outside Ladder Bracket.

Install Outside Ladder Brackets to Outside Wall Sheets as follows.



Use 5/16” x 3/4” Whiz Lock bolts and nuts. **Double nut** with second 5/16” Whiz Lock nut.

Outside Ladder Bracket Placement down length of Dryer.

Outside Ladder Brackets support Outside Ladder with Safety Cage from garner of dryer to foundation. Place Outside Ladder Brackets so that Top Safety Cage will be centered directly below Tower Roof Access Port.

Tower Roof Access Port was positioned so Outside Ladder with Safety Cage can be installed to the left of a Vertical Channel.

- Bolt first Outside Ladder Bracket on Roof Band to Solid Wall Sheet seam, in first bolt hole to left of Vertical Channel.
- Bolt second Outside Ladder Bracket on Roof Band to Solid Wall Sheet seam, in fourth bolt hole to left of Vertical Channel.
- Repeat above steps on next seam (which is between two solid Wall Sheets), then on every other seam on outside of dryer.

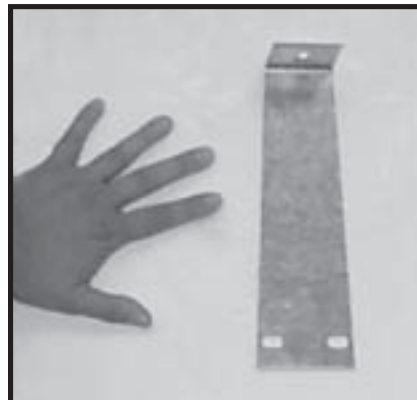

Photo 4-2 Outside Ladder Bracket.

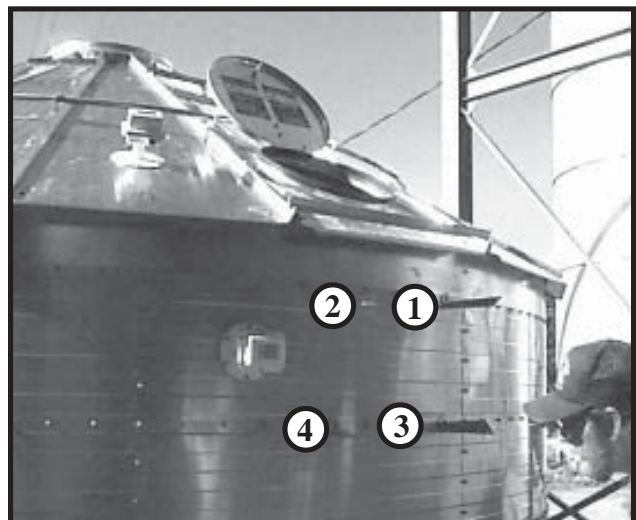

Photo 4-3 First four Outside Ladder Brackets loosely bolted below Tower Roof Access Port, marked (1),(2), (3) &(4).

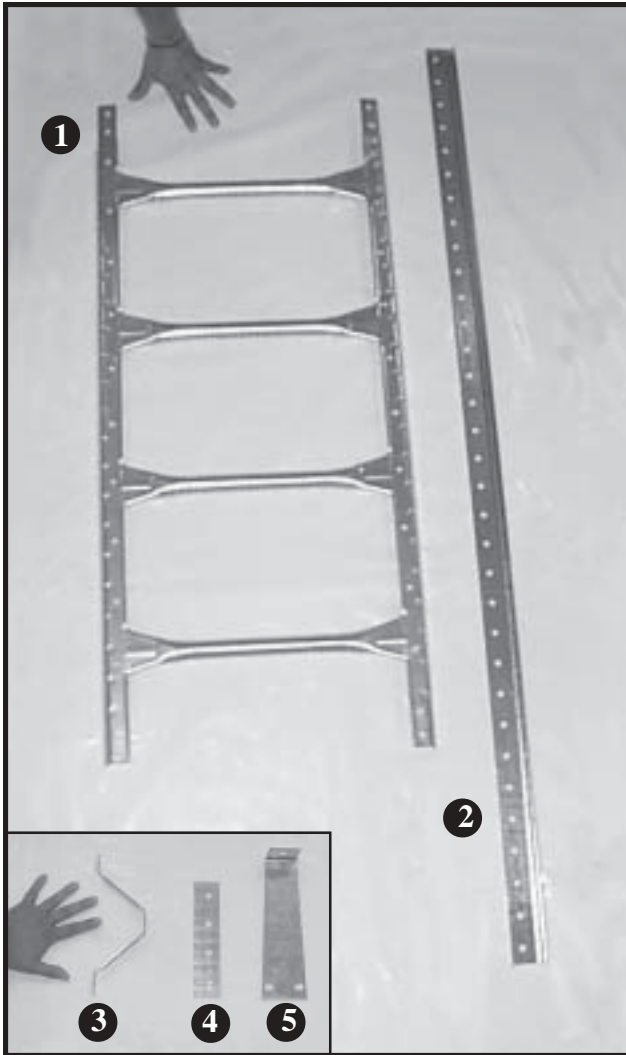

Photo 4-4

Outside Ladder

- (1) 44" Formed Ladder Section
(also used on Inside Ladder)
- (2) Outside Ladder Stiffener
- (3) Inside Ladder Standoff
(only used on Inside Ladder)
- (4) Ladder Stiffener Splice
- (5) Outside Ladder Bracket

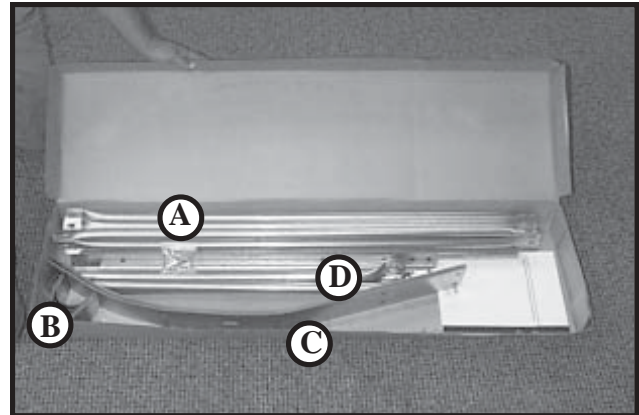

Photo 4-5 Top Safety Cage.

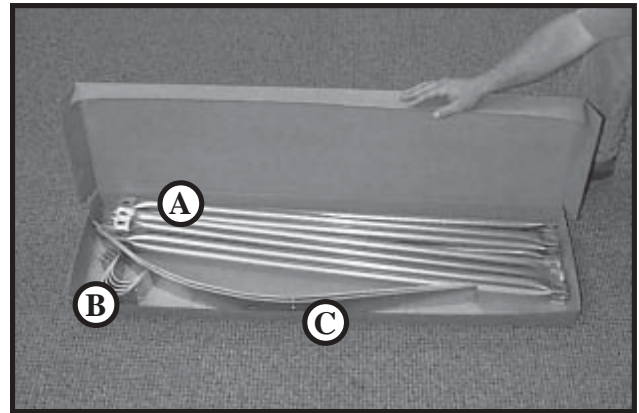

Photo 4-6 Safety Cage Extension.

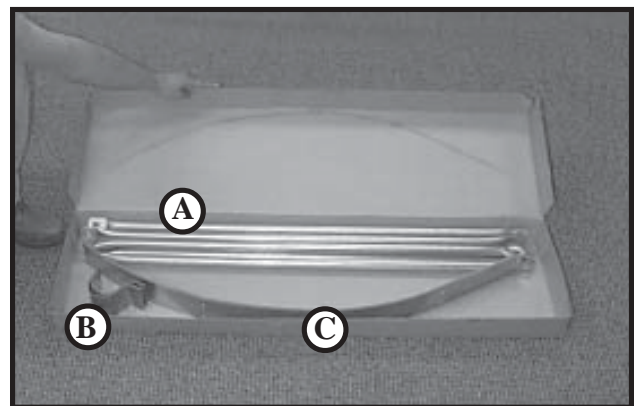

Photo 4-7 Bell Safety Cage has larger bell-shaped hoops.

Safety Cage

- (A) 44" Vertical Supports
- (B) Safety Cage Brackets
- (C) Safety Cage Hoop Halves
- (D) End Tubes and Center Tubes

4.2. Top Safety Cage

Pre-assemble Top Safety Cage as follows. (Photos 4-8 & 4-9)

- 4.2.1.** Snug bolt (1) 44" Formed Ladder Section to (2) Outside Ladder Stiffeners. Snug bolt (4) Safety Cage Brackets to Outside Ladder Stiffeners.
- 4.2.2.** Bolt pairs of Safety Cage Hoop Halves together. Snug bolt Safety Cage Hoops to Safety Cage Brackets.
- 4.2.3.** Snug bolt (7) 44" Vertical Supports to Safety Cage Hoop Halves.
- 4.2.4.** Snug bolt Top Safety Cage Assembly to Outside Ladder Brackets. Tighten bolts.



Photo 4-8

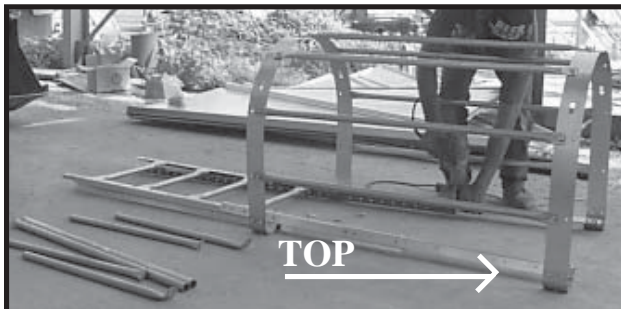

Photo 4-9



Install all 44" Formed Ladder Sections so rungs with rough, textured side for gripping are on top, so climbers do not slip.



When Assembling Ladder and Safety Cage

Use 5/16" x 3/4" galvanized Whiz Lock bolts and nuts.

When Installing Ladder and Safety Cage to Dryer

Use 5/16" x 3/4" stainless steel Whiz Lock bolts and nuts, and double nut Outside Ladder Brackets to Dryer.



LADDER BOLTS - insert bolts toward outside of ladder, so climbers do not snag on bolt shafts.



Photo 4-10 Close Up - Shaft of bolts point out of safety cage so climbers do not snag.

- 4.2.5.** Secure Top Safety Cage to Tower Roof ribs as follows.
- With common bolt, snug bolt first End Tube to Outside Ladder Stiffener.
 - Fit Center Tube into first End Tube.
 - Fit second End Tube into Center Tube.
 - Snug bolt second End Tube to rib of Tower Roof above Tower Roof Access Port with existing 5/16" x 1-1/4", grade 5 Bolts, Hex Head nuts, and Neoprene Washers.



- 4.2.6.** Square Top Safety Cage Assembly.



Check to be sure Top Safety Cage Assembly is plumb with dryer, then tighten bolts.



Install all 44" Formed Ladder Sections so rungs with rough, textured side for gripping are on top, so climbers do not slip.



Photo 4-11 Installing Top Safety Cage to Tower Roof.

4.3. Safety Cage Extensions.

Install Safety Cage Extensions from Top Safety Cage to Bell Safety Cage just above foundation as follows.

Quantity depends upon dryer model.

4.3.1. Splice Outside Ladder Stiffeners with Ladder Stiffener Splices. Snug bolt Outside Ladder Stiffeners behind 44" Formed Ladder Sections. Install Safety Cage Brackets and Safety Cage Hoops like Top Safety Cage.

4.3.2. Before lifting each section, tighten bolts in Outside Ladder with Safety Cage for that section.

As dryer is constructed, continue installing Safety Cage Extensions to each section of dryer before lifting it.



Photo 4-12 Close Up - pointing to Ladder Stiffener Slice. Install Ladder Stiffener Splice with 4 bolts (circle).



Photo 4-13 Outside Ladder Bracket bolts through 44" Formed Ladder Sections and Outside Ladder Stiffener.



Photo 4-14 Close Up - Outside Ladder Brackets.



Photo 4-15 As dryer is constructed, continue installing Outside Ladder with Safety Cage.

4.4. While installing each Catwalk, install Outside Ladder with Safety Cage.

4.4.1. **Above Catwalk.** Halt Safety Cage 7' 8' above Catwalk. Continue Outside Ladder through Catwalk.

4.4.2. **Below Catwalk.** Measure, cut, and install Safety Cage "44 Vertical Channel Supports to meet bottom of Catwalk. Continue installing Outside Ladder with Safety Cage.

4.5. **While installing each Platform, secure Outside Ladder with Safety Cage to it.** Bend and cut Safety Hoops to meet Vertical Uprights on Catwalk or Platform. Trim Safety Hoops back where necessary for access to Platform.



Photo 4-16 Close Up - Securing Safety Hoop to Vertical Support.



Photo 4-17 Ground View - Ladder with Safety Cage installed through Catwalks and to Platform.



Photo 4-18 Close Up - Installing upper and lower Safety Hoops to Platform Vertical Supports.



Photo 4-19 View from Platform - Safety Hoops installed to Platform Vertical Supports.

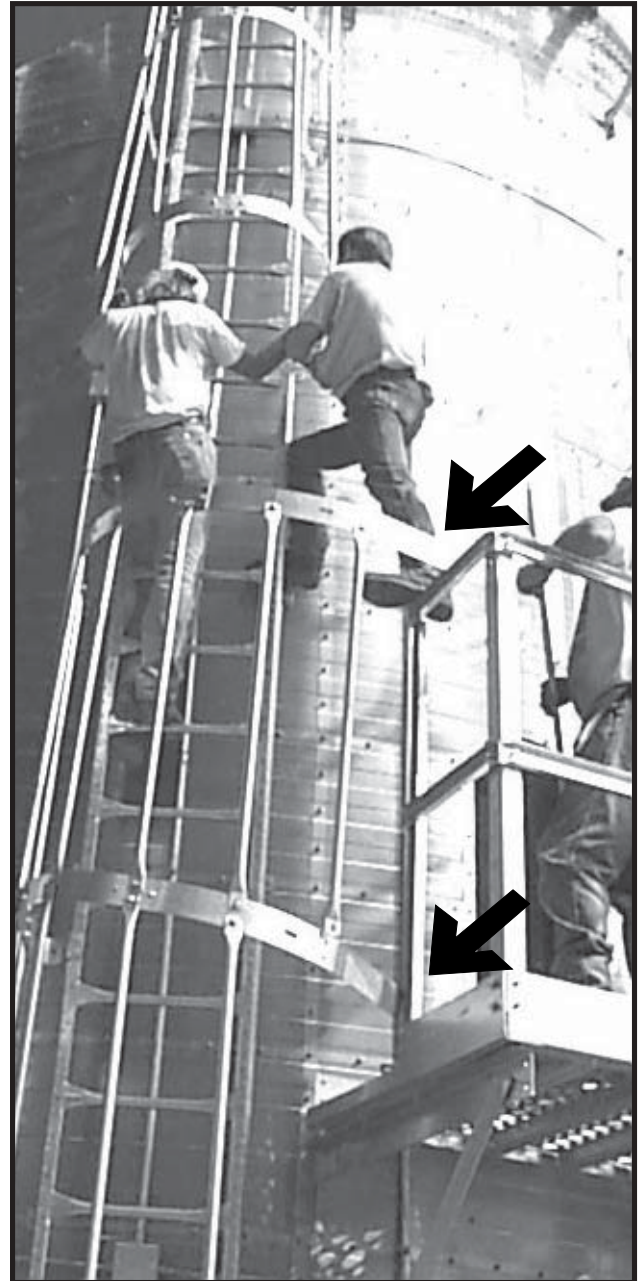

Photo 4-20 Trim and bolt Safety Hoops to Platform Vertical Support as necessary.



Photo 4-21 Close Up - installing Bell Safety Cage.

4.6. Bell Safety Cage.

About 10' above foundation, install Bell Safety Cage as the last section of the Outside Ladder with Safety Cage. Install like Safety Cage Extensions.



Photo 4-22 Bell Safety Cage installed.

4.7. Outside Ladder from Bell Safety Cage to foundation

4.7.1. Continue installing Outside Ladder (no safety cage) from Bell Safety Cage until Outside Ladder meets foundation.

4.7.2. Ladder Support Channels.

 Install Ladder Support Channels after X-Rods are installed.

 Use 5/16" x 3/4" stainless steel Whiz Lock bolts and nuts.

Measure and drill dryer Legs on both sides of Outside Ladder for (3) Ladder Support Channels. Space equally.

Bolt (3) Ladder Support Channels to span dryer Legs.

 Ladder Bracket Extensions offset Outside Ladder at base of dryer for ease in mounting ladder. Install as follows.

Bolt Outside Ladder Brackets to Outside Ladder.

Bolt Ladder Bracket Extensions to Outside Ladder Brackets. (The bracket [of both angle parts should face the same way.)

Bolt Ladder Bracket Extensions to Ladder Support Channels.

4.7.3. Outside Ladder Support.

Support bottom of Outside Ladder to concrete foundation. Length of support varies. Support not supplied by Grain Systems.

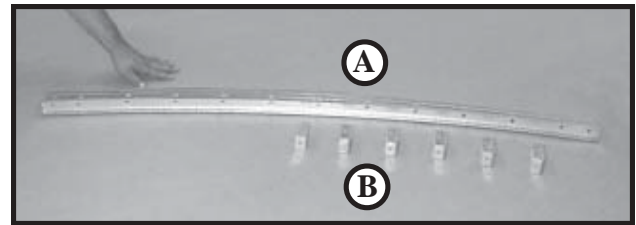

Photo 4-23

(A) Ladder Support Channel
(B) Ladder Bracket Extensions

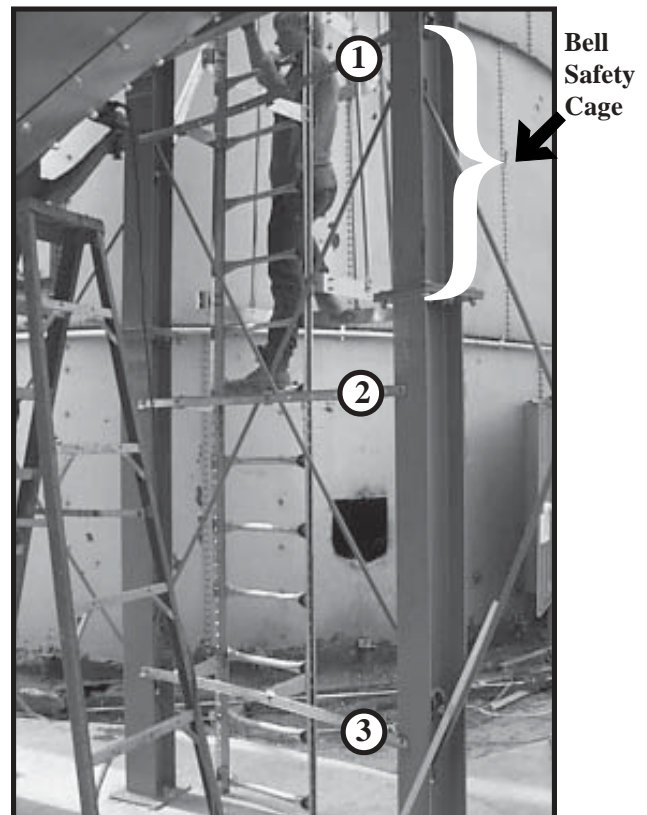
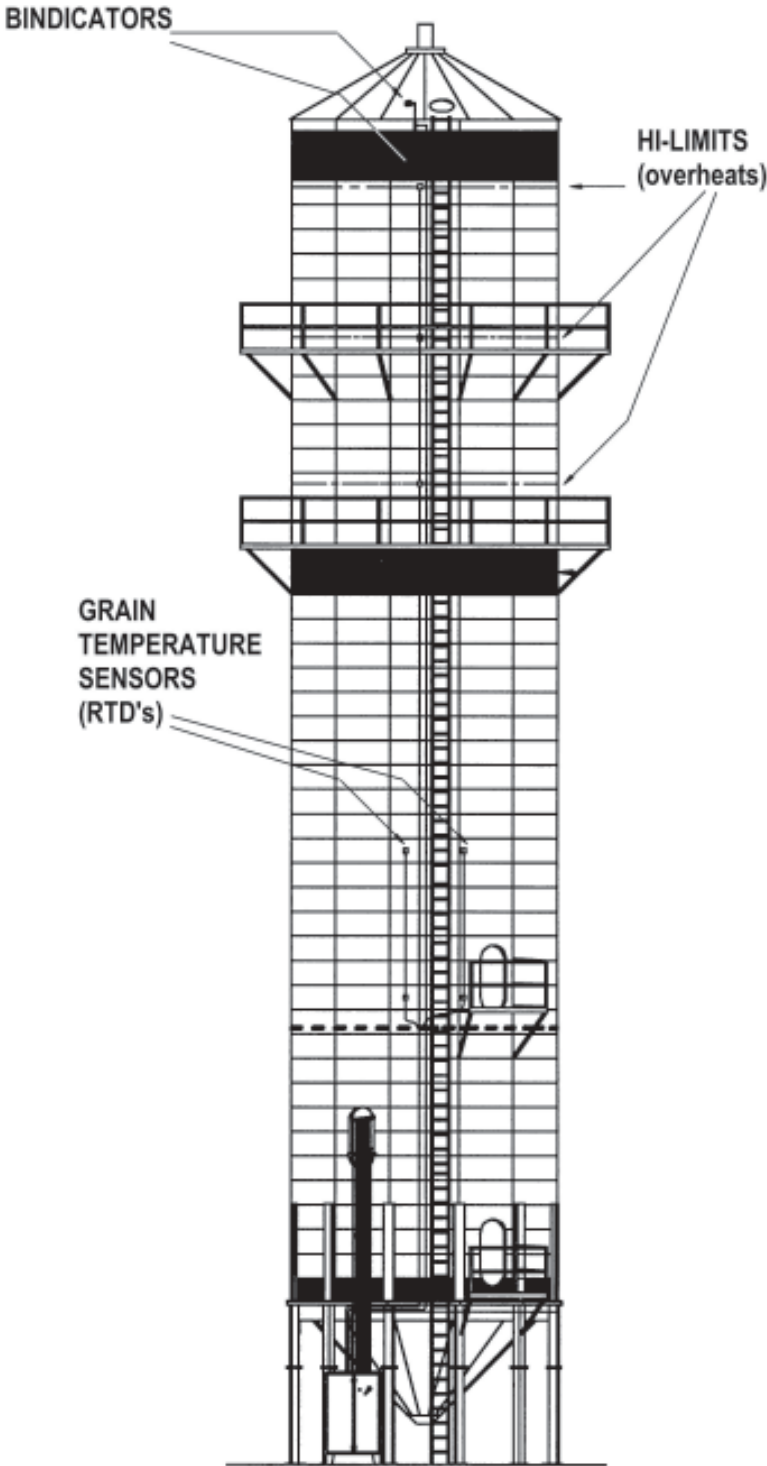

Photo 4-24 Bracing ladder at base of tower with Ladder Support Channels, marked (1),(2) & 3).

Usually Outside Ladder Support can be made of 1" x 1" x 1/8" angle iron bolted directly to Outside Ladder, using 5/16" x 1" bolts and nuts.

Illustration 5-1
Sensors Placement



18' Tower Dryer Construction

Illustration 5-2
Bindicator(s) Placement - detail

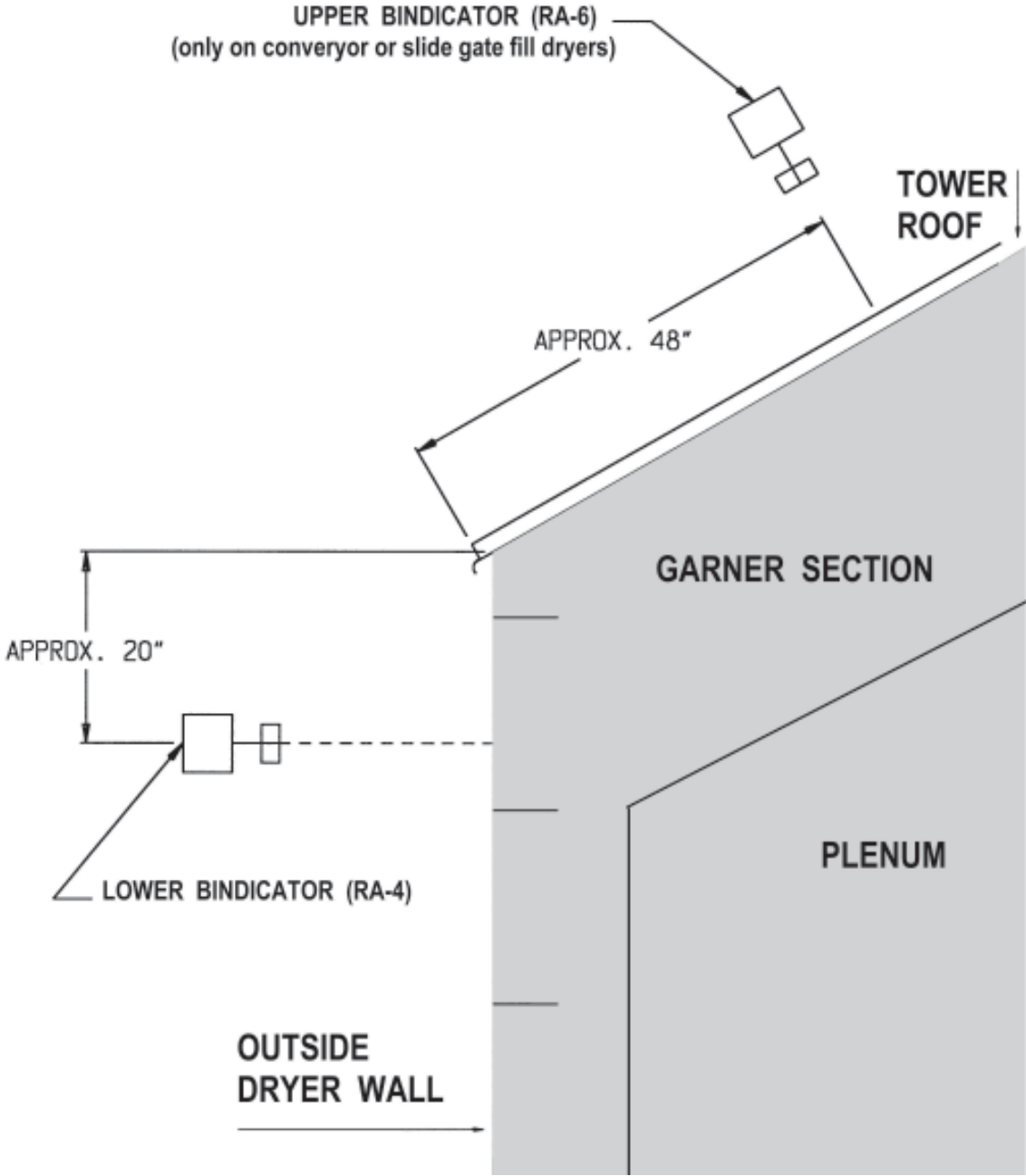



Important Safety Precautions:

Dryer has sharp edges. These sharp edges may cause serious injury. Use appropriate Personal Protective Equipment. Use proper lifting techniques.



See Chapter 1 “Orientation” for dryer dimensions, components, wall sheet guidelines, etc.
See Appendices for “Tools and Equipment”, “Hardware”, etc.

5. Sensors (outside)

Bindicator(s)

Grain Temperature Sensor (RTDs, Resistance Temperature Device)

Hi-Limits (overheats)

SUMMARY

Bindicator(s)

Lower Bindicator is installed on side of dryer, just below garner section of dryer.
Upper Bindicator is only installed on conveyor or slide gate fill dryers. Install Bindicator(s) within easy reach of Outside Ladder for later wiring.

Electricians will install conduit and wire Bindicator(s).

Grain Temperature Sensors (RTDs)

Two pairs of Grain Temperature Sensors (a total of four sensors on two 10' conduits) are installed within reach of Outside Ladder.

Electricians will install conduit and wire Grain Temperature Sensors.

Hi-Limits (overheats)

Upper Hi-Limit, Middle Hi-Limit, and Lower Hi-Limit (each with copper tubing) are installed on perforated sheets, between top row of solid sheets and (just above or just below) middle row of solid sheets (at Grain Turners). Locate Junction Boxes under Outside Ladder.

Construction crew will install conduit connecting Hi-Limits and continue conduit down to about 10' above foundation. Electricians will wire Hi-Limits.



Hardware



Photo 5-1 1/2" IMC rigid, threaded conduit.

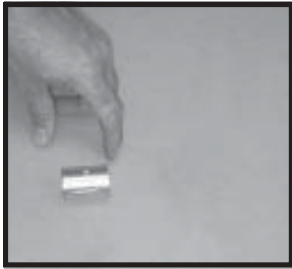

Photo5-2 1/2" Conduit Coupling.



Photo5-3 1/2" Conduit Hanger.



Photo 5-4 Insulated Clip.

Bindicator Parts

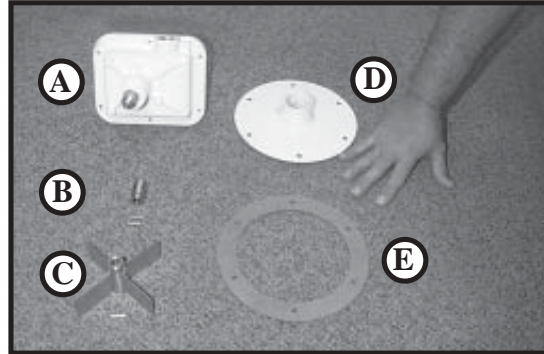

Photo 5-5 Bindicator as shipped.

- (A) Bindicator Base
- (B) 1-1/4" x 3/8" Pipe Coupling, with (2) Roll Pins
- (C) Four Vane Paddle, with (1) Roll Pin
- (D) Mounting Bracket
- (E) Gasket

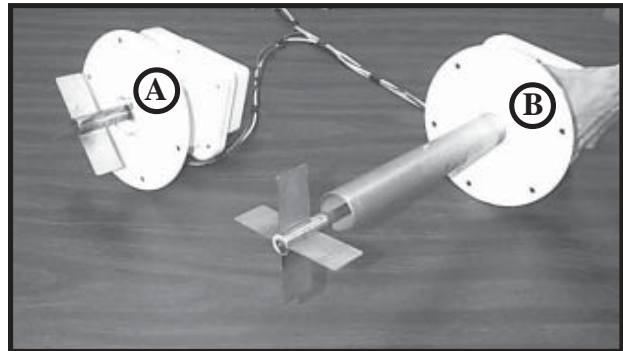

Photo 5-6 Bindicators (wired for demonstration)

- (A) Lower Bindicator, RA4 (installed on all dryers)
- (B) Upper Bindicator, RA6
(install only on conveyor or slide gate fill dryer)



Photo 5-7

- (A) 12" x 1/4" Pipe Guard
- (B) 12" x 1/8" Extension Pipe

5.1. Bindicator(s).

Assemble Bindicator(s) according to Instruction Sheet packed with them.

- ☞ See Illustration 6-2 for placement of Bindicator(s).

5.1.1. Lower Bindicator, RA4.

- ✓ Measure inner (not outer) diameter of Gasket. This is the diameter of hole needed to mount Lower Bindicator on Wall Sheet.

Locate Wall Sheet directly below Access Port. Center hole vertically on that Wall Sheet. Cut a hole in Wall Sheet that measures the same as Gasket inner diameter.

Install assembled Lower Bindicator into hole cut in Wall Sheet, fitting Gasket tight against Wall Sheet.



Bolt with 5/16" x 3/4" Whiz Lock bolts and 5/16" nuts.

5.1.2. Upper Bindicator, RA6.

If required (for conveyor or slide gate fill dryers only), install Upper Bindicator on dryer roof.

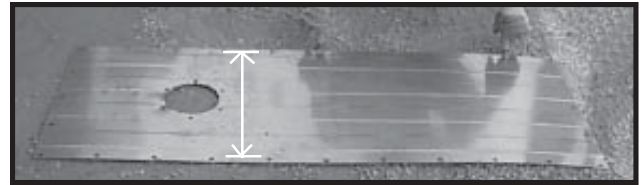

Photo 5-8 Center hole vertically for Bindicator (arrows).



Photo 5-9 Installing Upper Bindicator.

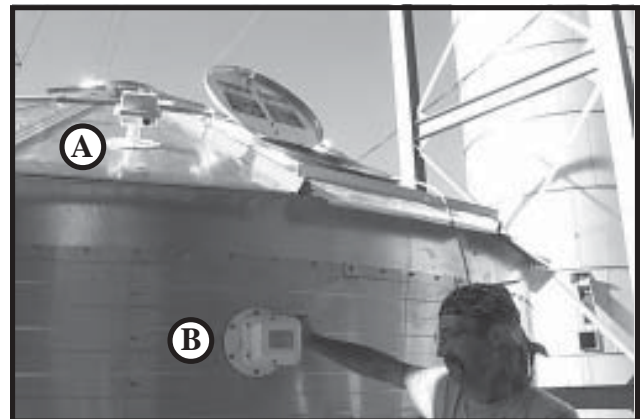

Photo 5-10 Upper Bindicator (A) and Lower Bindicator (B) installed.

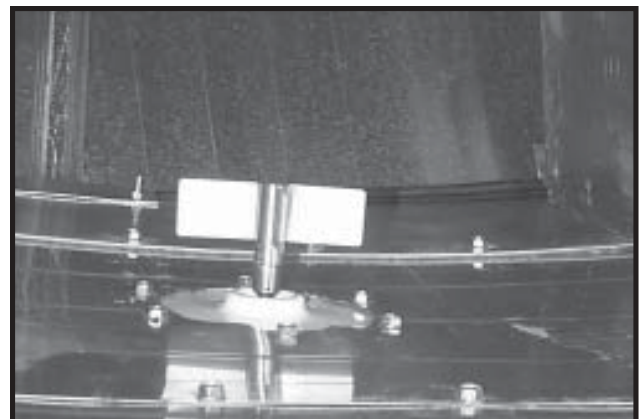



Photo 5-11 View inside dryer - Lower Bindicator.

5.2. Hi-Limits (overheats).

Install Upper, Middle and Lower Hi-Limits on outside of dryer.

 See Illustration 5-1 for placement.

 For sensors to work properly, it is important to install Hi-Limits on perforated sheets.

Position junction boxes with drainage holes down and behind Outside Ladder Screw in Conduit. Secure Conduit close to Junction Box with 1/2" Conduit Hangers on existing bolts on seam.

Wrap copper tubing entirely around dryer. Clip with Insulated Clips.

INSTALLING COPPER TUBING

- Install horizontal copper tubing as straight as possible and flush to dryer.

Secure copper tubing with Insulated Clips every 40". Insulated Clips can be nipped down with second nut over existing nut.

 **Caution:** do not kink or cut off end of gas-filled copper tubing.

INSTALLING CONDUIT FOR HI-LIMITS

- Install one 1/2", 10' IMC rigid, threaded Conduit between each Hi-Limits. Continue Conduit down to approximately 10' above foundation.
- Join Conduit lengths with 1/2" Conduit Couplings.
- Run conduit parallel or perpendicular to other conduits and dryer features.
- Vertical conduit run should be plumb, neat, and orderly.
- Conduit fittings must be dust-tight, rain-tight, and satisfy any hazard requirements for the site.
- Seal all threads with Pipe Thread Sealer to tighten seals and prevent leaks.
- Use 1/2" Conduit Hangers every 80", and 5/16" x 3/4" Whiz Lock bolts.

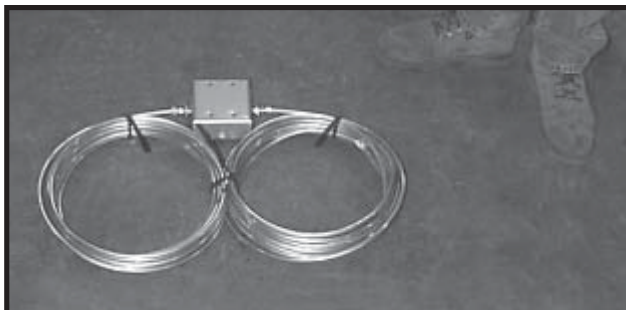

Photo 5-12 One (outside) Hi-Limit consists of (1) junction box and (2) copper tubings.

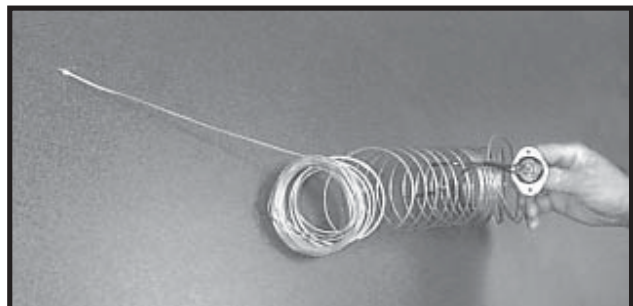

Photo 5-13 High Limits sensor with gas-filled capillary. Capillary is installed inside copper tubing at factory. Caution: do not kink or cut off end of copper tubing.

5.2.1. Install Upper Hi-Limits.



Photo 5-14 Upper Hi-Limit installed with junction box under Outside Ladder (arrow).

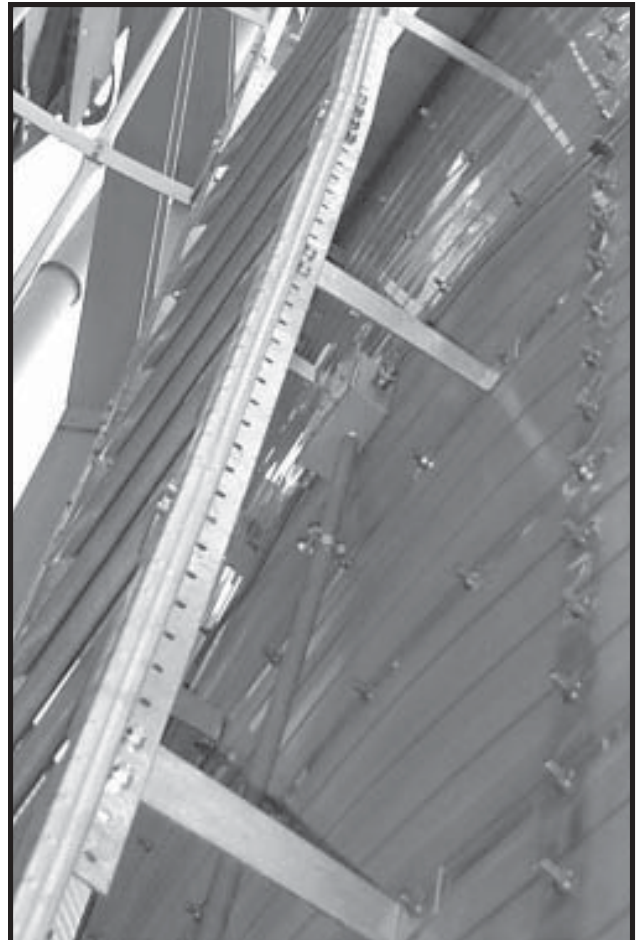

Photo 5-15 Close Up - Upper Hi-Limit installed with junction box positioned under Outside Ladder.

5.2.2. Install Middle Hi-Limits.

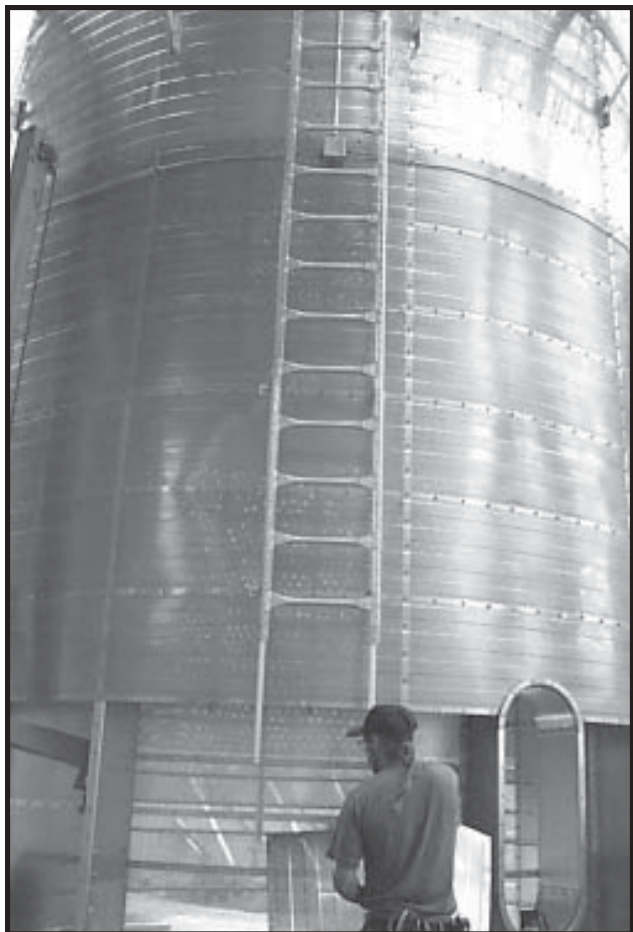

Photo 5-16 Middle Hi-Limit installed.



Photo 5-17 Caution - do not cut ends of Copper Capillary Tubing. Overlap them.

5.2.3. Install Lower Hi-Limits.



*Photo 5-18 Installing Lower Hi-Limit.
Note: Outside Ladder will install over Junction Box.*



*Photo 5-19 Installing copper capillary tubing with
Insulated Clips.*



Photo 5-20 Close Up.

5.3. Grain Temperature Sensors (RTDs).
 Install RTDs on outside of dryer, within safe reach of ladder.

There are (2) RTDs on each of two 10' lengths of 1/2" conduit.

Position RTDs according to Illustration 5-1. Drill hole in dryer wall for sensing bolt on each RTD. Add (1) 3/8" washer to bolt/washer already on each RTD. Insert sensing bolt in hole. Secure Conduit near RTD with 1/2" Conduit Hanger. Use existing bolts on seam.



Do not place nut on inside of Outside Screen.

PLACEMENT OF RTDs

Either RTD can be installed in top position.

RH PAIR

of RTDs. Install to right of Outside Ladder, and within reach of Outside Ladder.

Place RH-Bottom RTD just above heat section floor.

RH-Top RTD is on same conduit, 10' above Bottom RH Sensor.

LH PAIR

of RTDs. Install in next grain column over from RH pair of RTD, at the same level as RH pair, and within reach of Outside Ladder.

INSTALLING CONDUIT FOR RTDs

- Run conduit parallel or perpendicular to other conduits and dryer features.
- Vertical conduits should be plumb, neat, and orderly.



Photo 5-21 A pair of RTDs on (1) 10' length of conduit. Note either RTD on conduit can be installed in top position.

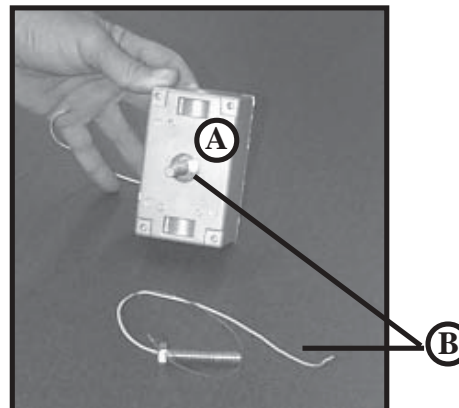

Photo5-22

- A. RTD - Grain Temperature Sensor
- B. Sensing bolt - grain sensor is embedded in stainless steel bolt



Photo 5-23 Installing LH pair of RTDs.



Photo 5-24 Close Up of LH-Bottom RTD - securing conduit near sensor with 1/2" conduit hanger on existing bolt on seam.

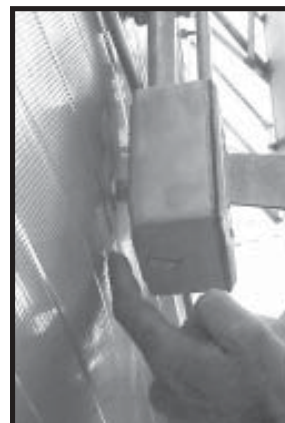

Photo 5-25 Close Up - RTD bolt with sensor.



Important Safety Precautions:
Dryer has sharp edges. These sharp edges may cause serious injury. Use appropriate Personal Protective Equipment. Use proper lifting techniques.



See Appendices for “Recommended Tools and Equipment List”, “Hardware”, etc.

6. Decal - GSI

The standard location for the GSI Decal is on the side of the dryer that can be seen from the operating facility and/or from access road. GSI Decal will be centered on top two solid Wall Sheets, just below roof section. Remove nuts and bolts from the seam of those two solid Wall Sheets.

Remove backing from GSI Decal. Center and apply GSI Decal to top two solid Wall Sheets. Smooth out air bubbles. Remove masking from front of GSI Decal. Drill out bolt holes and replace bolts.



Photo 6-1.



Photo 6-2.

**Important Safety Precautions:**

Dryer has sharp edges. These sharp edges may cause serious injury. Use appropriate Personal Protective Equipment. Use proper lifting techniques.



See Chapter 1 “Orientation” for dryer dimensions, components, wall sheet guidelines, etc. See Appendices for “Tools and Equipment”, “Hardware”, etc.

7. STEPS to Lift Dryer

Vertical Channel Splice.

Splice Vertical Channels together with Vertical Channel Splices.



Use 3/8” x 1” galvanized steel bolts and nuts.

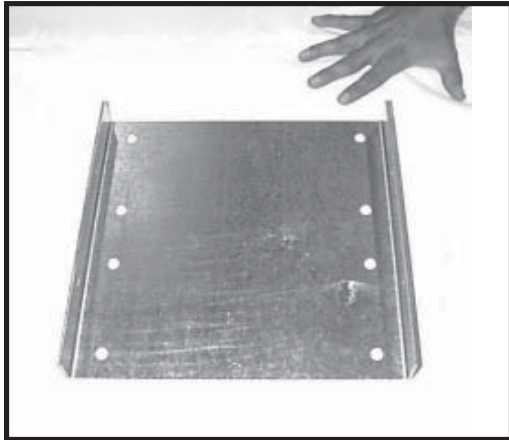

Photo 7-1 Vertical Channel Splice, 10 gauge

Universal Shim Plate.

To level dryer, shim dryer legs with Universal Shim Plates. Use Universal Shim Plates only for leveling jacks and completed dryer.

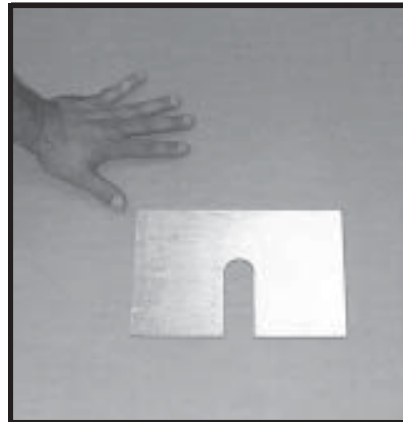



Photo 7-2 Universal Shim Plate.
Use only for leveling jacks and completed dryer.



✓ Safety Check before each lift.

- Tighten all bolts on dryer (except lower ladder parts).
- Check for clearance from existing power lines, equipment and structures (see Chapter 1).
- Do not lift dryer when it is windy enough to shift jacked dryer.
- Move next set of Vertical Channels near to dryer, and install Vertical Channel Splice to them.

EXAMPLE: Lifting Roof Section.

- ✓  Before lifting roof of dryer
Do safety check for wind or electrical hazards, clearance, etc. (see Chapter 1).

Tighten all bolts on dryer (except lower Ladder parts).

Apply GSI Decal.

- 7.1. Install Vertical Channel Splice Plates to Vertical Channels to be installed after lift. Move Vertical Channels near to dryer.
- 7.2. Place (4) jacks around dryer as explained in “Lifting Dryer Guidelines”, Chapter 1, “Orientation”.
- 7.3. Attach hoisting tackle from each jack to (2) Lift Brackets according to jack manufacturer’s instructions. Span (2) Lift Brackets with lift bar so jacks do not block vertical rows of bolt holes.
- 7.4. Unbolt Dryer from Jig Clips. Lift Dryer to clear next set of 80” Vertical Channels. Operate jacks according to jack manufacturer’s instructions.
- 7.5. Slide each Pre-spliced Vertical Channel (splice end up) to a Vertical Channel already on dryer, and position with alignment punches. Snug up lower Vertical Channel into upper Vertical Channel as tightly and evenly as possible.
- 7.6. Lower dryer.

- ✓ Check to be sure bottom of Vertical Channel is on outside of Jig Clip.

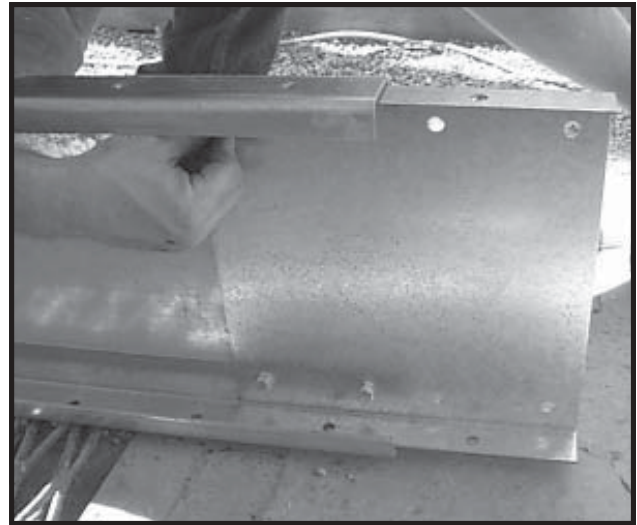

Photo 7-3 Splicing Vertical Channels.



Photo 7-4 Installing Lift Brackets.

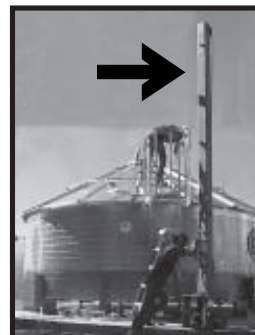

Photo 7-5 Placing jacks around dryer (arrow).

7.7. At top, loosely bolt Vertical Channel Splices to Vertical Channel already on dryer. At bottom, loose bolt Vertical Channels to Jig Clip to align dryer. Then tighten all bolts.

7.8. As each lift of dryer is constructed, install Wall Sheets, Ladders, Catwalks, Platforms, and other dryer features as required. (See Chapter 1, "Orientation".)



Photo 7-6 Positioning jack next to dryer.



Photo 7-8 Checking jack is plumb and level.

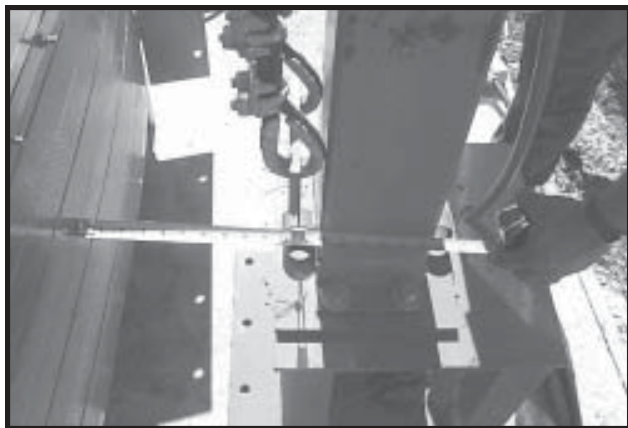

Photo 7-7 Checking jack is 11-1/2" to 12" from dryer.



Photo 7-9 Jacks in place around dryer.



Photo 7-10 Raising dryer.



Photo 7-12 Aligning Vertical Channels.



Photo 7-11 Sliding Vertical Channel up to Vertical Channel on dryer.



Photo 7-13 Bolting Vertical Channels.



Photo 7-14 Close Up - Bolting Vertical Channels.



Photo 7-16 Bolting Vertical Channel to Jig Clip.



Photo 7-15 Lowering Vertical Channel on outside of Jig Clip.



Photo 7-17 Removing Lift Bracket.

Catwalks 8 & Platforms

Illustration 8-1
Outside Catwalk

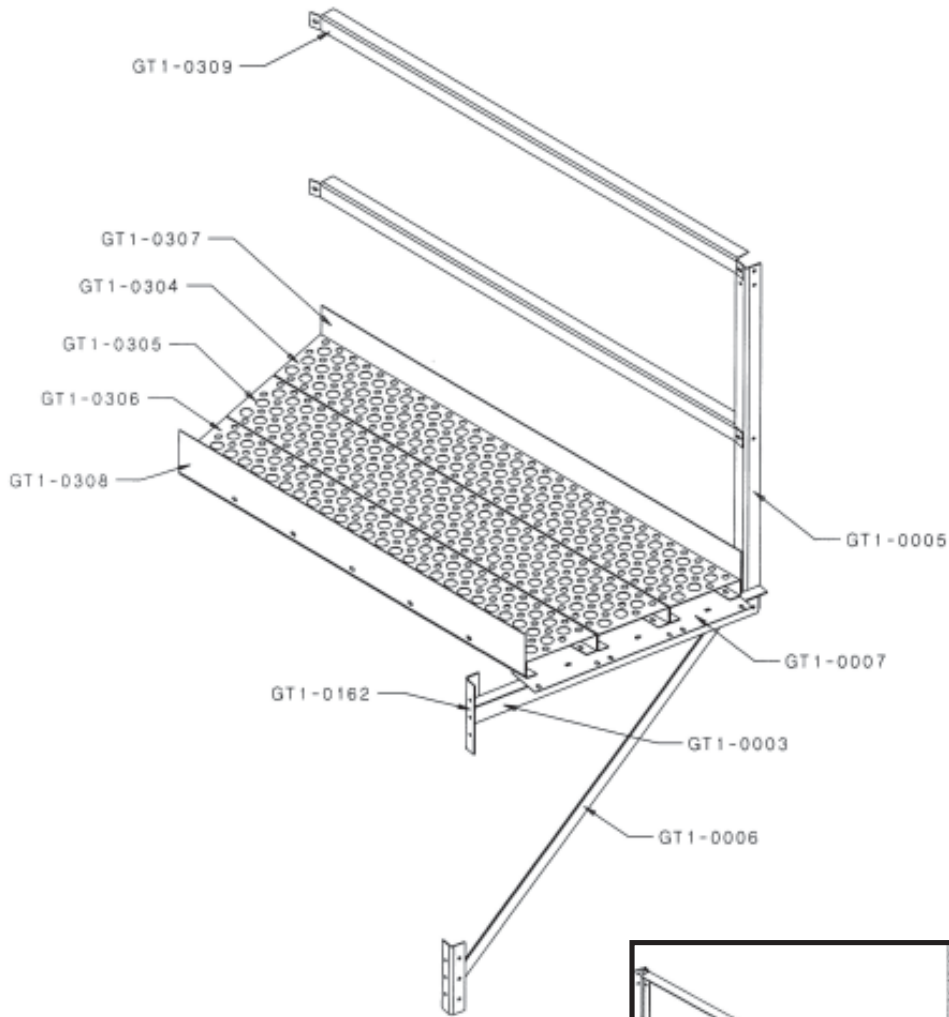

PART NO.	DESCRIPTION	QTY.
GT1-0003	CATWALK FLOOR SUPPORT	16
GT1-0005	CATWALK VERTICAL SUPPORT	16
GT1-0006	CATWALK 45 SUPPORT	16
GT1-0007	CATWALK SPLICE PLATE	16
GT1-0162	CATWALK SUPPORT CLIP	32
GT1-0304	LARGE FLOOR PLANK	15
GT1-0305	MEDIUM FLOOR PLANK	15
GT1-0306	SMALL FLOOR PLANK	15
GT1-0307	OUTER TOEBOARD	15
GT1-0308	INNER TOEBOARD	15
GT1-0309	CATWALK HANDRAIL	32

Quantity is for one Outside Catwalk.

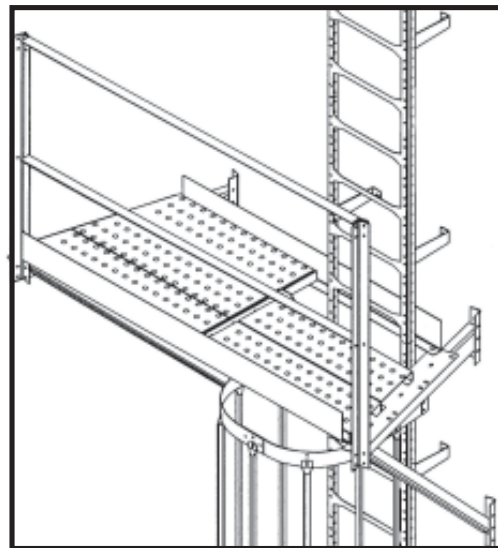

Note Ladder runs through Catwalk.

Illustration 8-2
Inside Catwalk

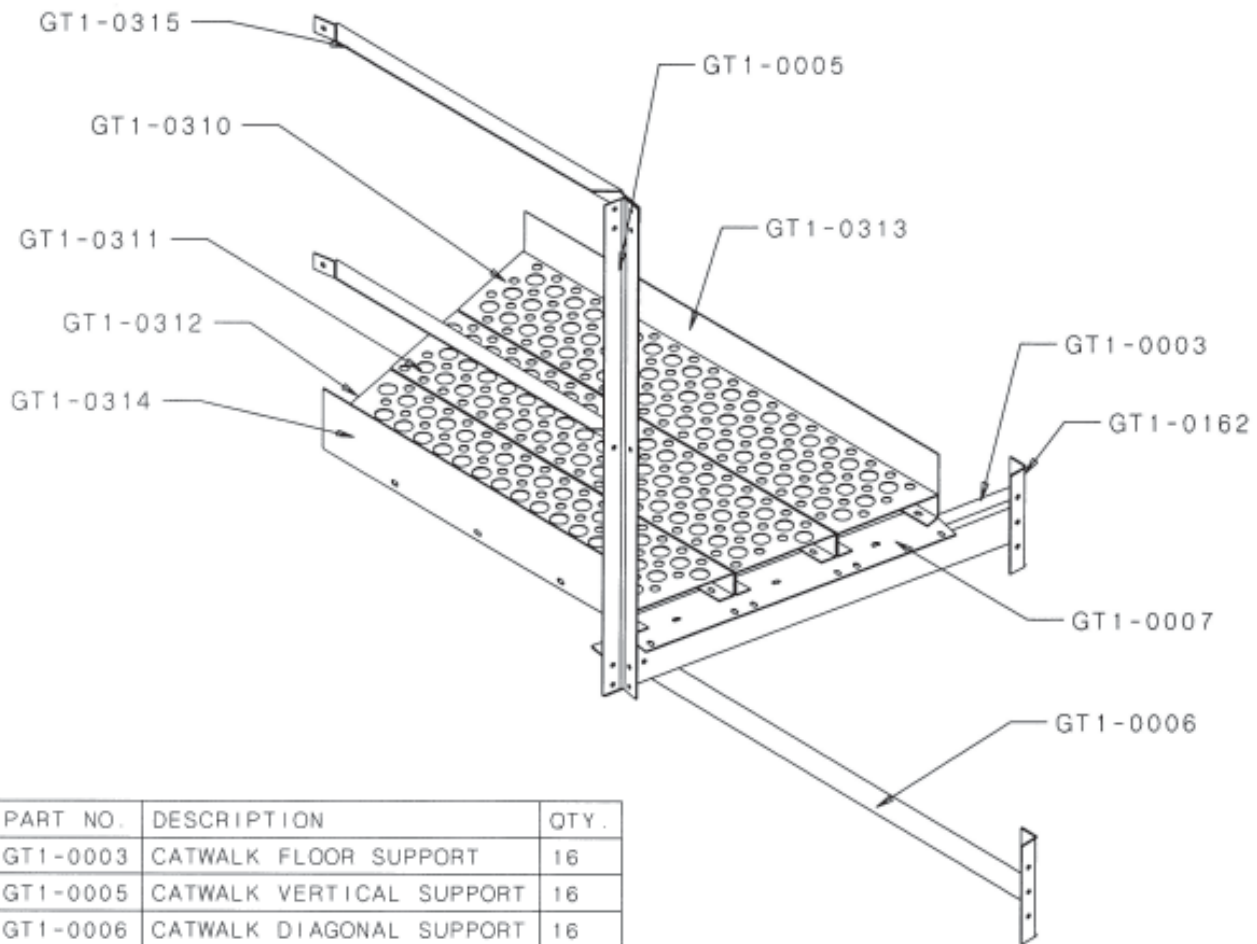

PART NO.	DESCRIPTION	QTY.
GT1-0003	CATWALK FLOOR SUPPORT	16
GT1-0005	CATWALK VERTICAL SUPPORT	16
GT1-0006	CATWALK DIAGONAL SUPPORT	16
GT1-0007	CATWALK SPLICE PLATE	16
GT1-0162	CATWALK SUPPORT CLIP	32
GT1-0310	LARGE FLOOR PLANK	16
GT1-0311	MEDIUM FLOOR PLANK	16
GT1-0312	SMALL FLOOR PLANK	16
GT1-0313	OUTER TOEBOARD	16
GT1-0314	INNER TOEBOARD	16
GT1-0315	INNER CATWALK HANDRAIL	32

Quantity is for one Inside Catwalk.

Illustration 8-3
Platform

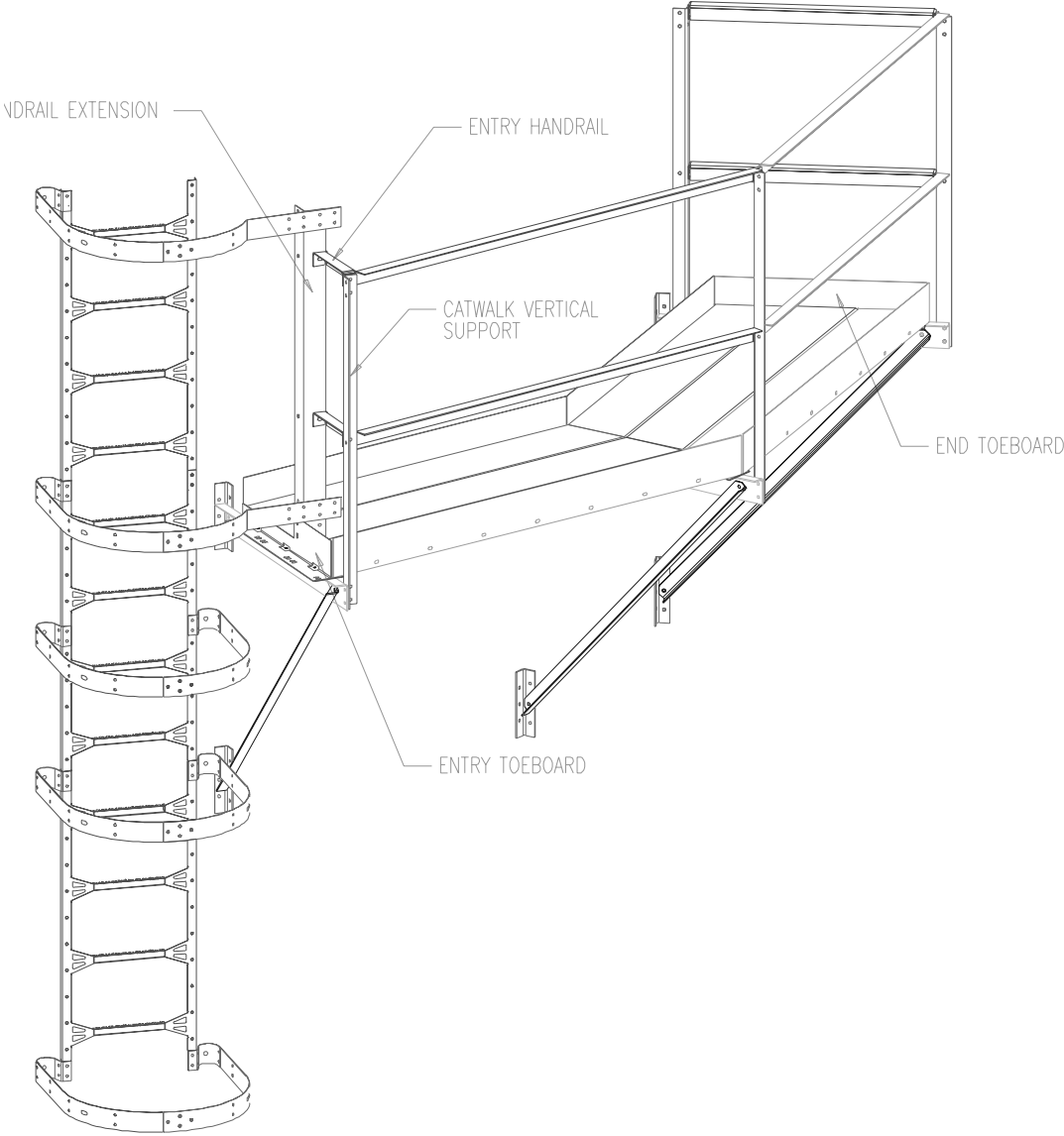

Note Safety Cage Tubing not shown for clarity.

Illustration 8-5
1st Outside Catwalk Position
Model 3000

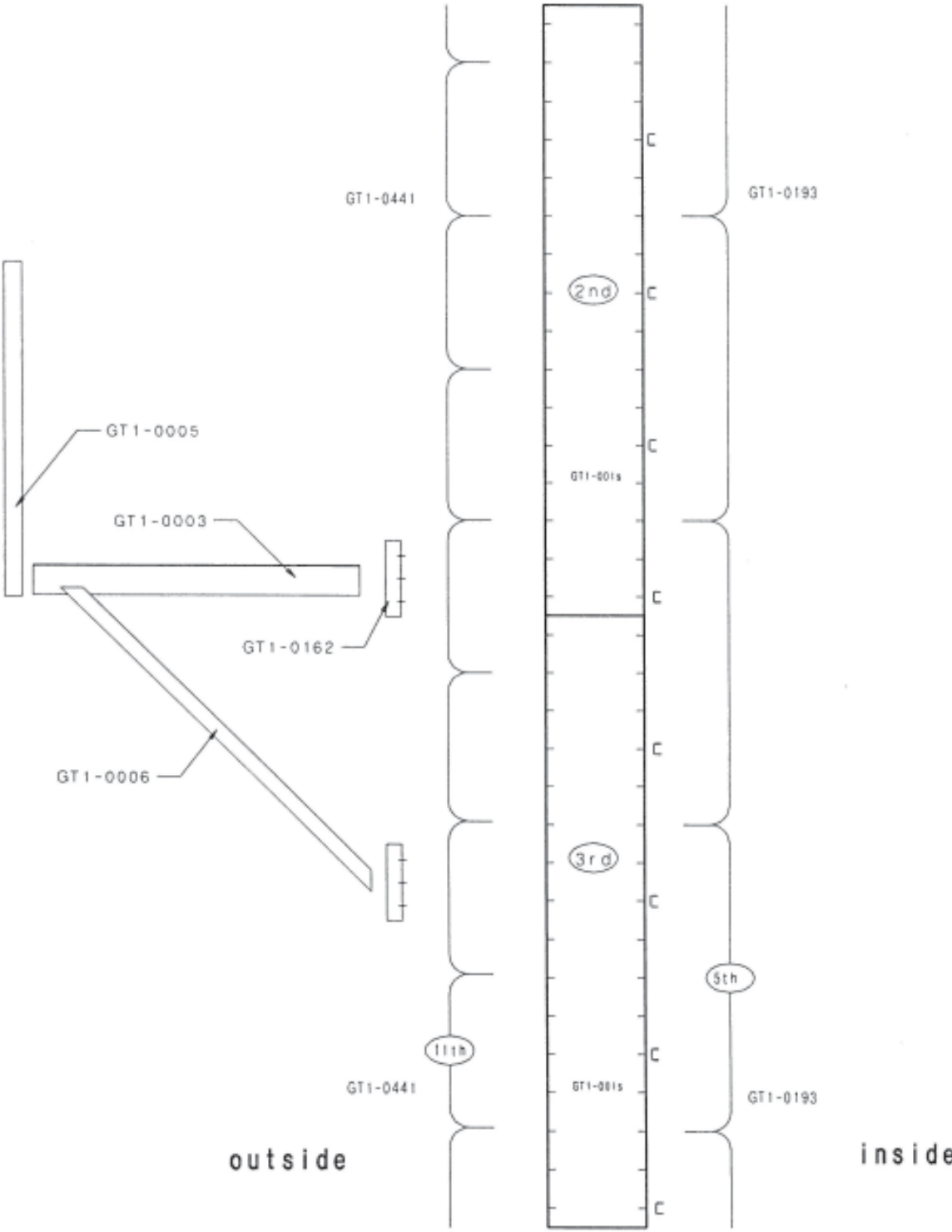

Illustration 8-6
2nd Outside Catwalk
& Inside Catwalk Positions
Model 3000

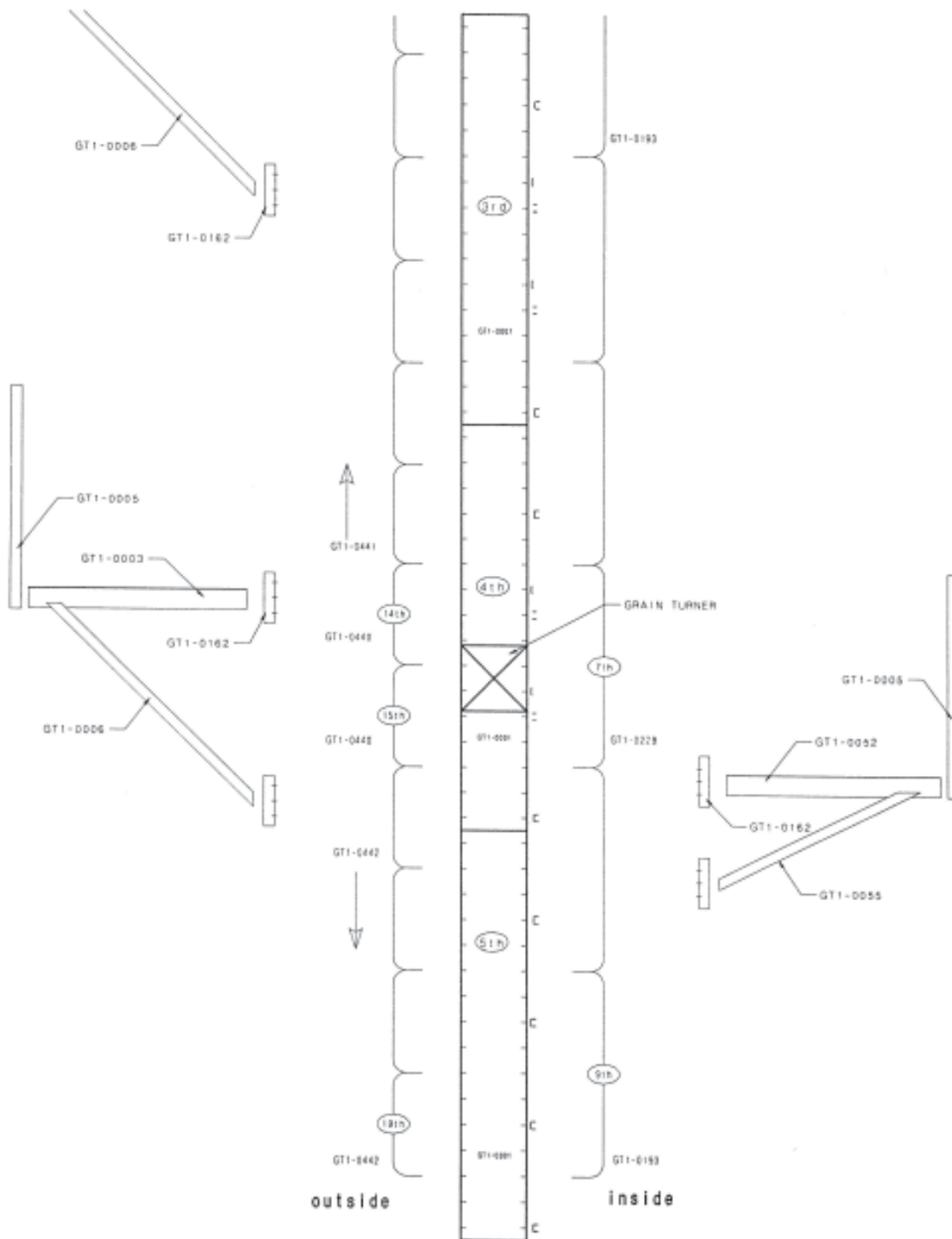

Illustration 8-7
1st Outside Catwalk Position
Model 3500

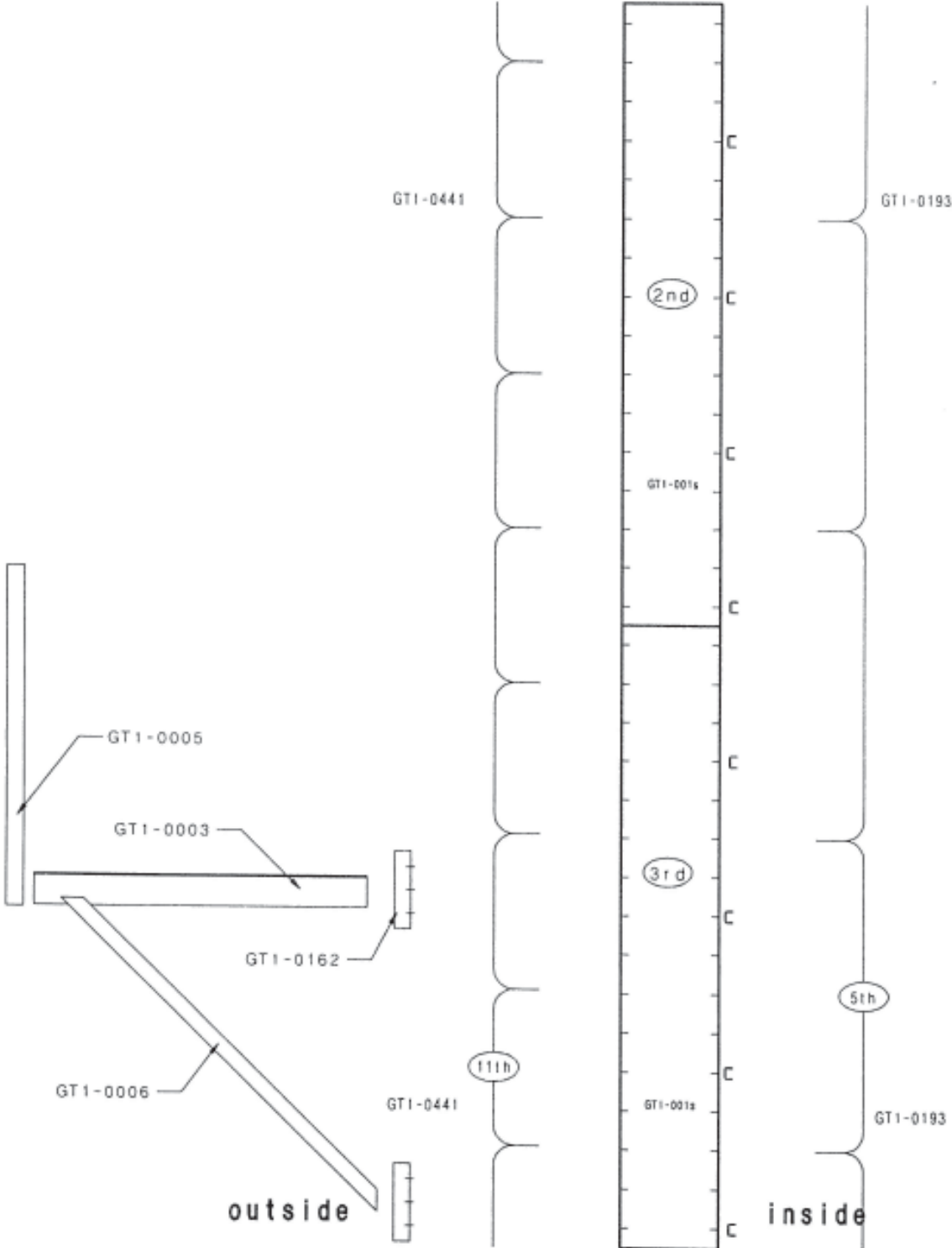

Illustration 8-8
2nd Outside Catwalk
& Inside Catwalk Positions
Model 3500

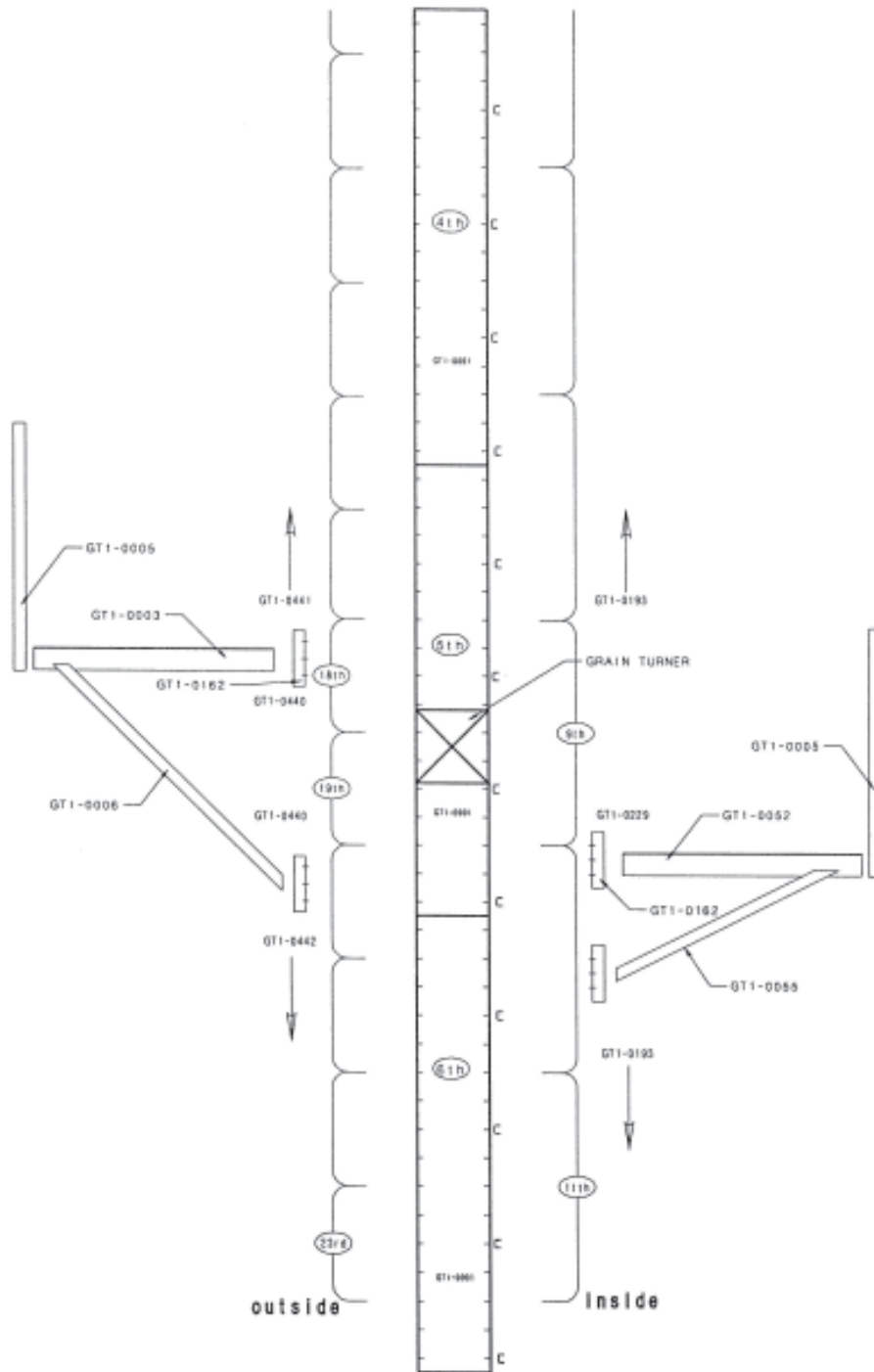

Illustration 8-9
First Outside Catwalk Position
Model 4000

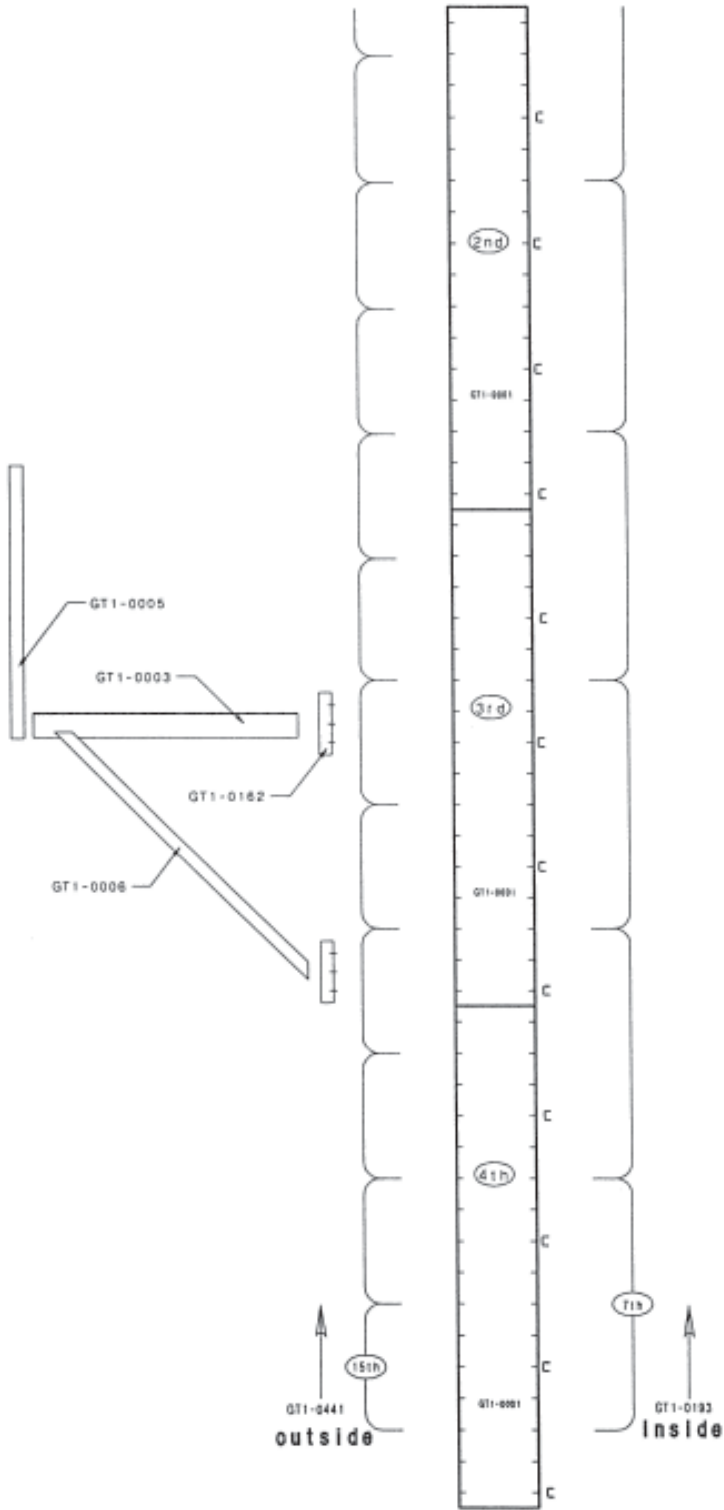
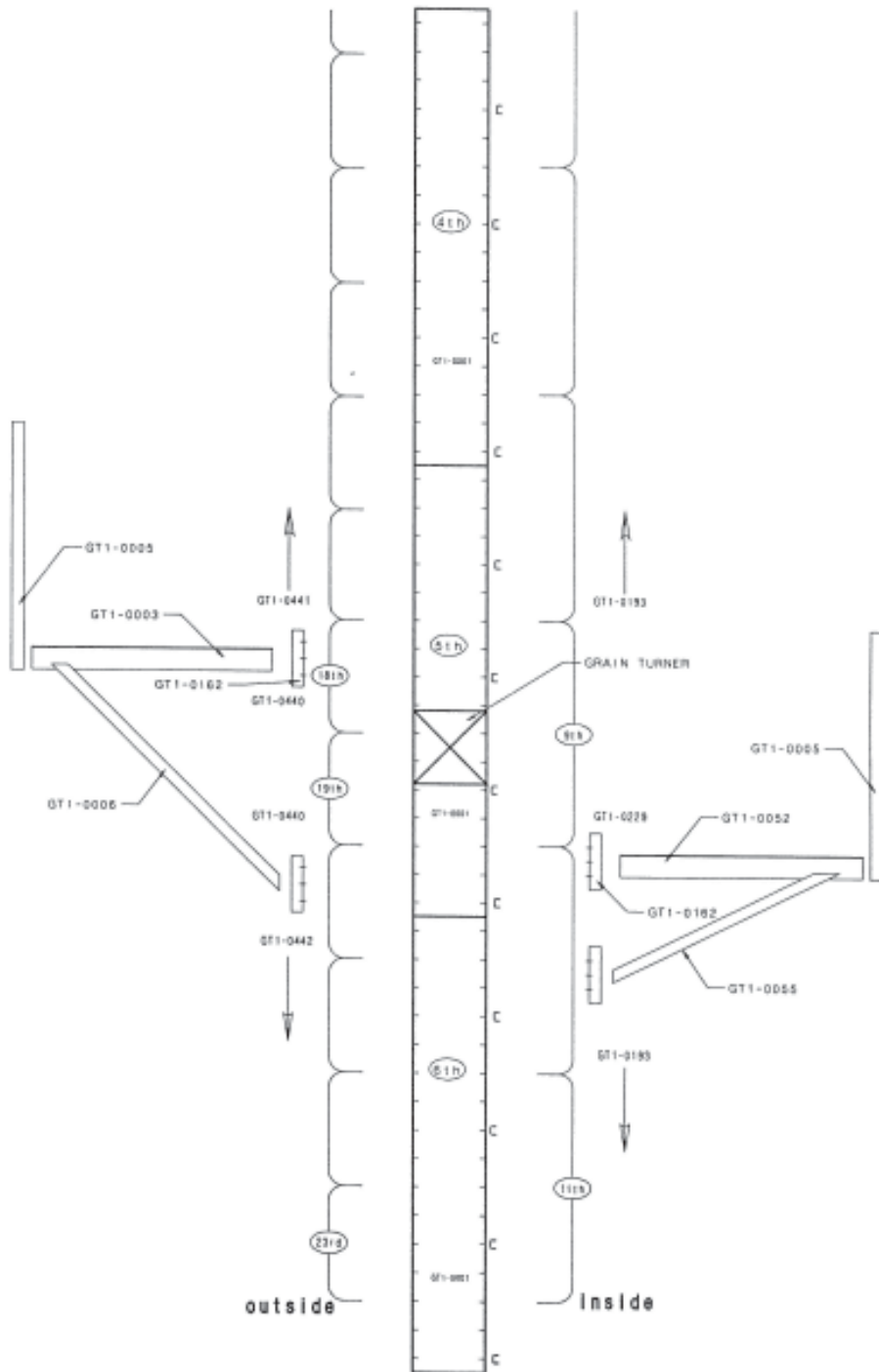

Illustration 8-10
2nd Outside Catwalk
& Inside Catwalk Positions
Model 4000



**Important Safety Precautions:**

Dryer has sharp edges. These sharp edges may cause serious injury. Use appropriate Personal Protective Equipment. Use proper lifting techniques.



See Chapter 1 “Orientation” for dryer dimensions, components, wall sheet guidelines, etc. See Appendices for “Tools and Equipment”, “Hardware”, etc.

8. STEPS - Catwalks & Platforms

8.1. Outside Catwalk(s). (1 or 2)

8.2. Inside Catwalk.

8.3. Platforms.

(1) Heat Section

(1) Cool Section

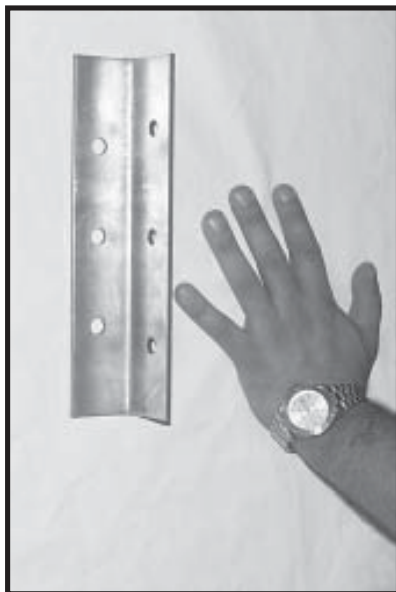

Photo 8-1 Catwalk Support Clip is used to install Outside Catwalk(s), Inside Catwalk, Heat Section Platform, and Cool Section Platform.

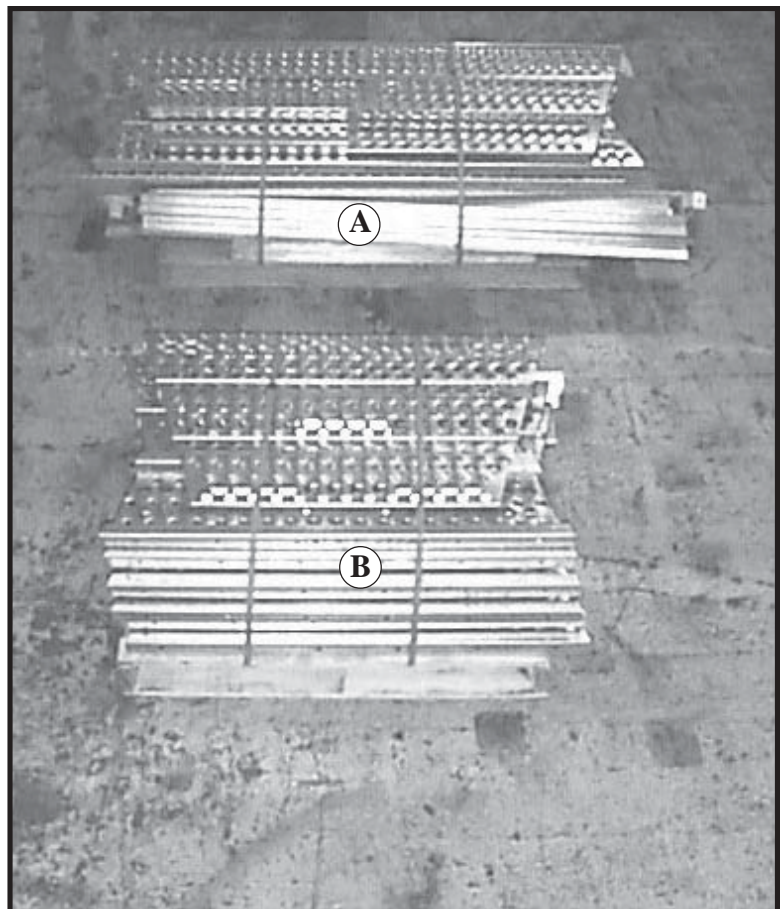

Photo 8-2

A. Outside Catwalk as shipped

B. Inside Catwalk as shipped

8.1. OUTSIDE CATWALK.

(* = door parts)

- A.* Outside Catwalk Hinged Door Section
- B.* Outside Catwalk Door Section
- C. Outside Catwalk Section
- D. Outside Catwalk Handrail
(use for upper and lower handrail)
- E.* Outside Catwalk Outside Door Toeboard
- F.* Outside Catwalk Inside Door Toeboard
- G. Outside Catwalk Outside Toeboard
- H. Outside Catwalk Inside Toeboard
- I. Outside Catwalk Diagonal Support
- J. Outside Catwalk Vertical Support
- K. Outside Catwalk Floor Support
- L. Outside Catwalk Splice Plate
- M. Catwalk Support Clip

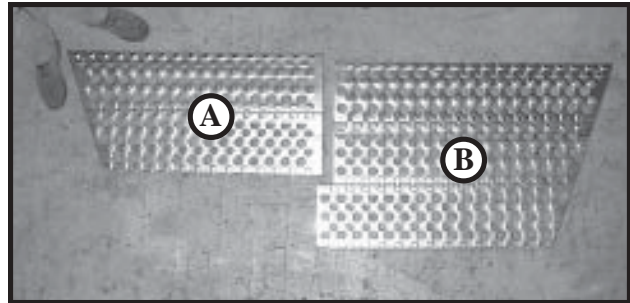

Photo 8-3

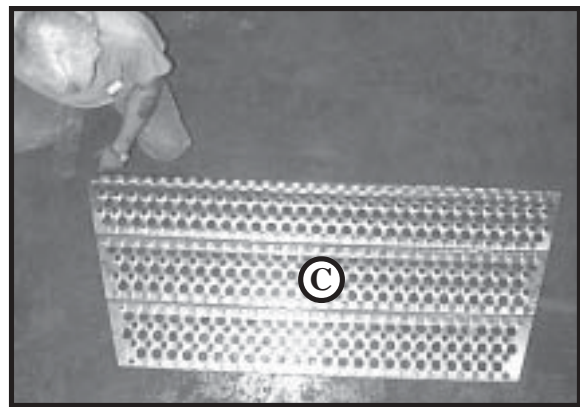

Photo 8-4

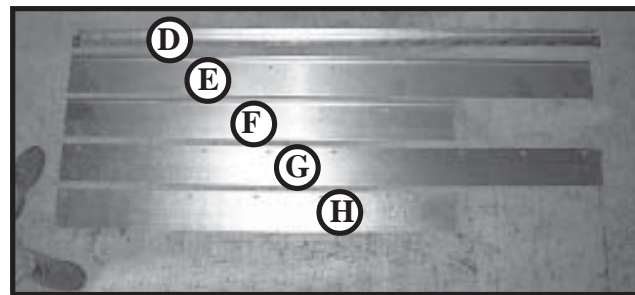

Photo 8-5

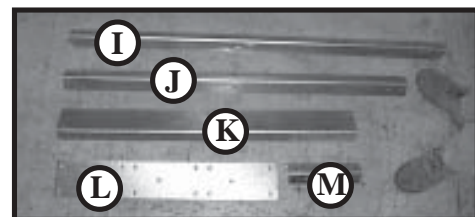

Photo 8-6

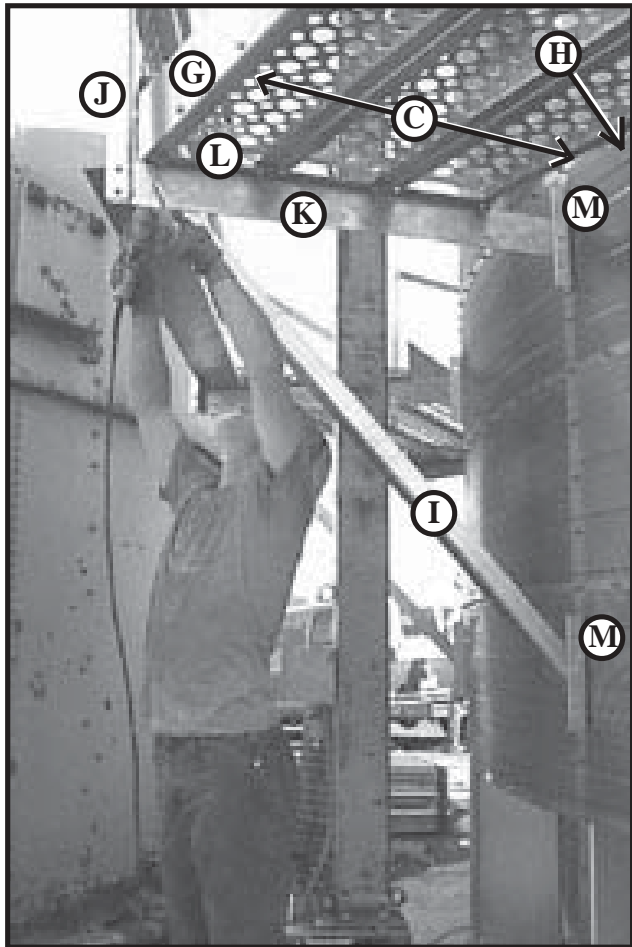

Photo 8-7 Parts are listed on previous page.

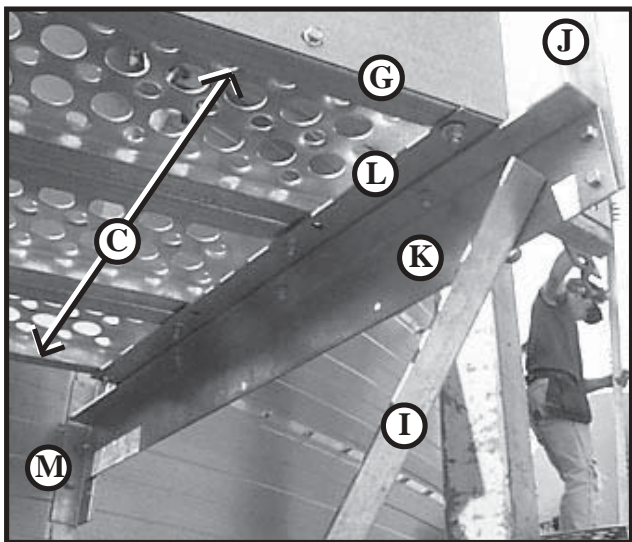



Photo 8-8 Parts are listed on previous page.

8.1. Outside Catwalk(s) continued.

 Use 5/16" x 3/4" Whiz Lock bolts and nuts to install Catwalk flooring.

Use 3/8" x 1" Whiz Lock bolts and nuts to install Handrails and Supports.

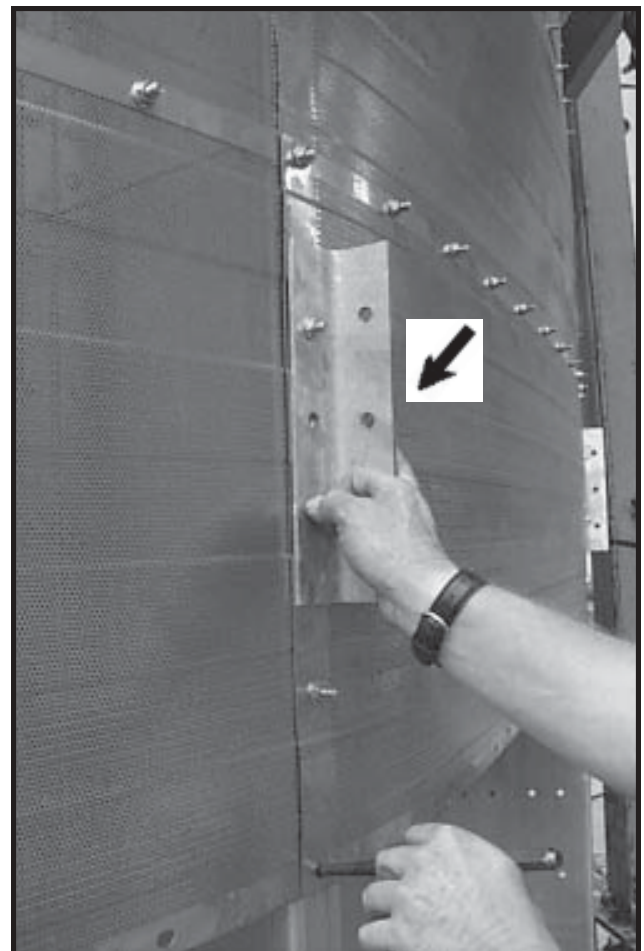

Photo 8-9 Catwalk Support Clip is installed with angle up on RH side.

8.1. Outside Catwalk continued

8.1.1. Snug bolt Outside Catwalk Diagonal Support to Outside Catwalk Support Clips around perimeter of dryer. (2 Catwalk Support Clips were installed on each Vertical Channel as Wall Sheets were installed.)

8.1.2. Pre-assemble Outside Catwalk Door (Photo 8-10) as follows. (Double nut at X for movement of parts.)

Bolt A at “X₁” to Outside Catwalk Outside Door Toeboard.

Bolt A at “X₂” to B.

Center Assembled Outside Catwalk Door between and just below ladder rung. Install.

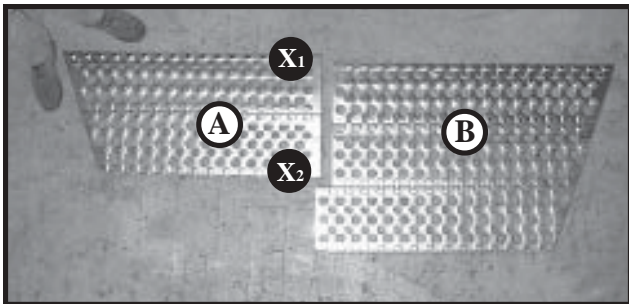

Photo 8-10 “X” marks hinge points for Outside Catwalk Door.

8.1.3. (On ground) assemble remaining catwalk flooring from Outside Catwalk Section and Outside Catwalk Toeboards.

8.1.4. Snug bolt Outside Catwalk Vertical Supports to Outside Catwalk Floor Supports.

8.1.5. Snug bolt upper and lower Outside Catwalk Handrails to Catwalk Vertical Supports.

8.1.6. Clamp pre-assembled catwalk flooring in each jack area (to be bolted after lifting dryer clear of jacks.) (Photo 8-11)

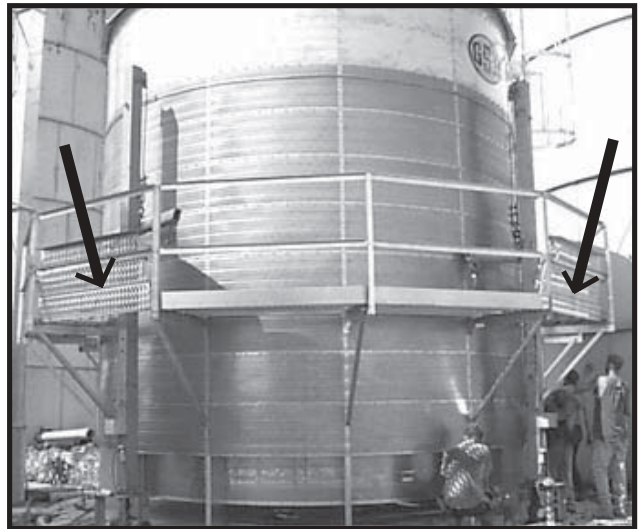

Photo 8-11 Catwalk installed with catwalk sections clamped where they will be installed after dryer is lifted clear of jacks.



8.1.7. Check uprights are plumb to the eye. Tighten bolts.

8.1.8. Lift dryer.

8.1.9. When catwalk is clear of jacks, place remaining catwalk flooring and bolt tight.



If required, install second Outside Catwalks using the same steps.

8.1. Outside Catwalk(s) continued.

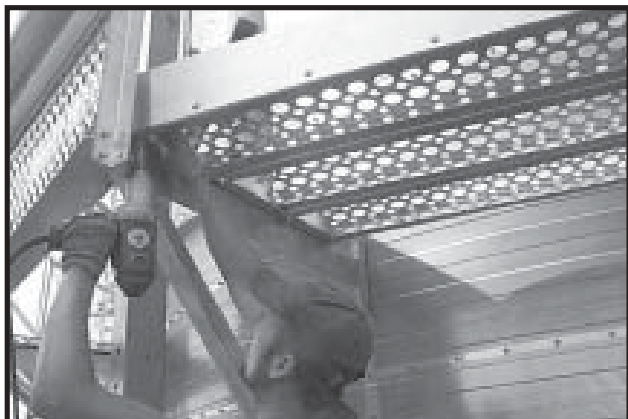

Photo 8-12 Tightening Outside Catwalk .



Photo 8-13 Tightening Outside Catwalk bottom Handrail.



Photo 8-14 Tightening Outside Catwalk top Handrail.



Photo 8-15 Outside Catwalk Door - open.



Photo 8-16 Outside Catwalk Door - closed.



Photo 8-17 Completed Outside Catwalks.

8.2. INSIDE CATWALK.

- A. Inside Catwalk Floor Brace
- B. Inside Catwalk Outside Toeboard
- C. Inside Catwalk Splice Plate
- D. Inside Catwalk Inside Toeboard
- E. Inside Catwalk Vertical Support
- F. Inside Catwalk Diagonal Support
- G. Inside Catwalk Handrail
- H. Catwalk Support Clip
- I. Inside Catwalk Section.

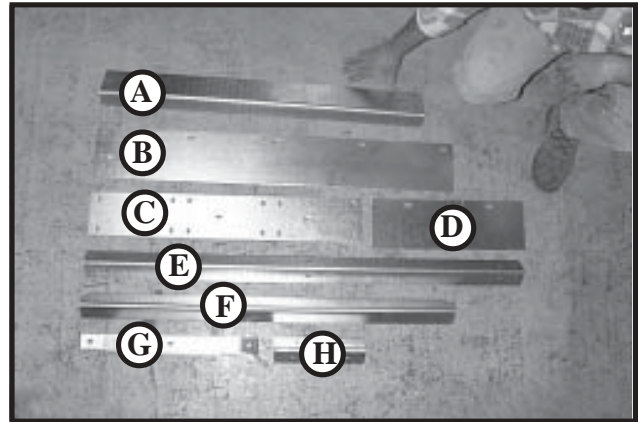

Photo 8-18

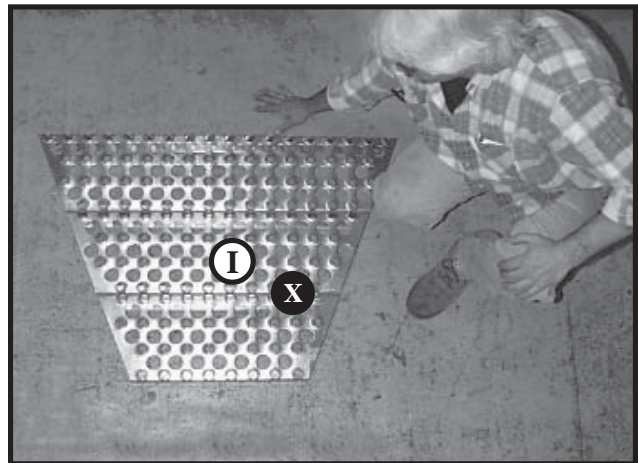



Photo 8-19 Inside Catwalk Section.
Also use for Inside Catwalk Door by hinging at "x".

For Inside Catwalk Door, install provided Continuous Hinge at "x" to (I) Inside Catwalk Section. See Photo 8-19.

 Use 5/16" x 3/4" Whiz Lock bolts and nuts to install Catwalk flooring.

Use 3/8" x 1" Whiz Lock bolts and nuts to install Handrails and Supports.

 Install Inside Catwalk parts in the same order as Outside Catwalk parts.

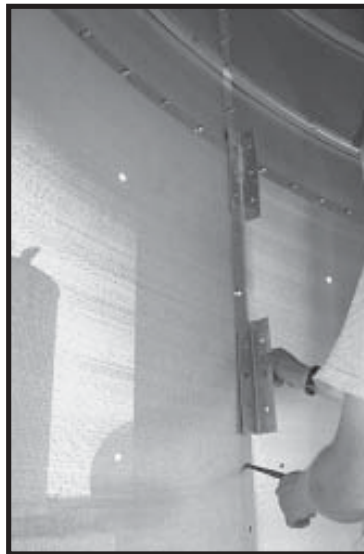

Photo 8-20 Catwalk Support Clip is installed with angle up on RH side.

8.2. INSIDE CATWALK.



Photo 8-21 Installing Inside Catwalk.

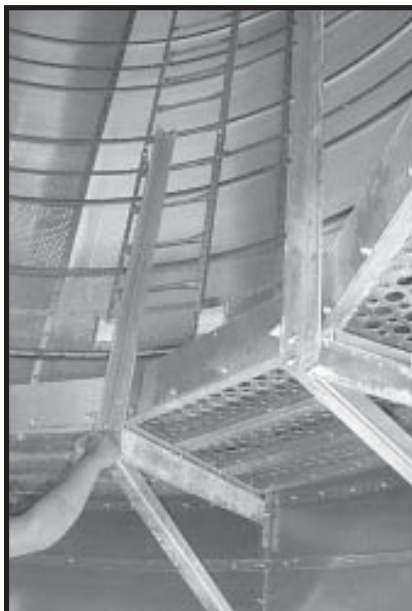

Photo 8-22 Bolting Inside Catwalk Vertical Support to Inside Catwalk Section.



Photo 8-23 Bolting Inside Catwalk Splice Plate to Inside Catwalk Section.

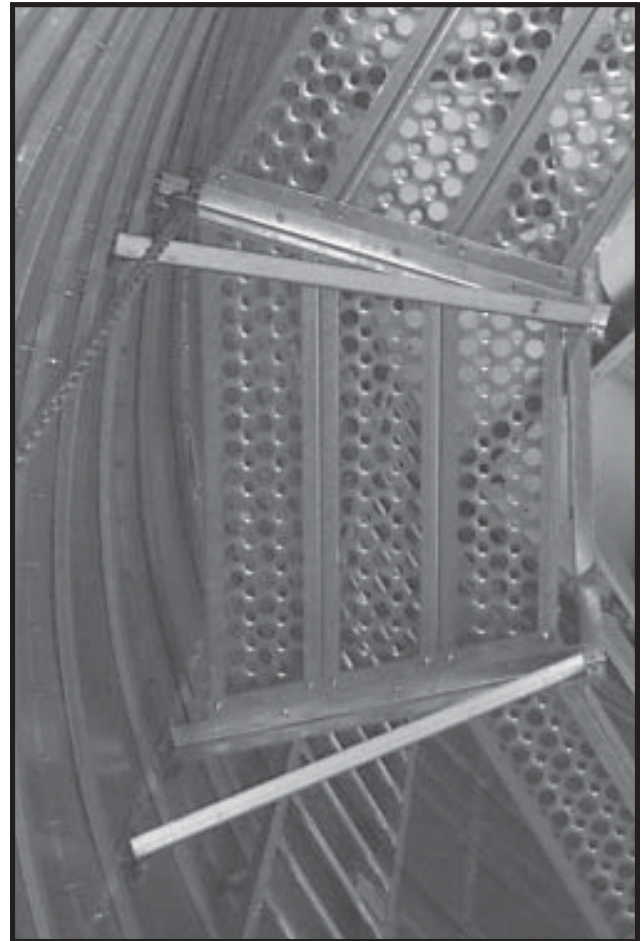

Photo 8-24 View from below - Completed Inside Catwalk.

8.2. INSIDE CATWALK. continued

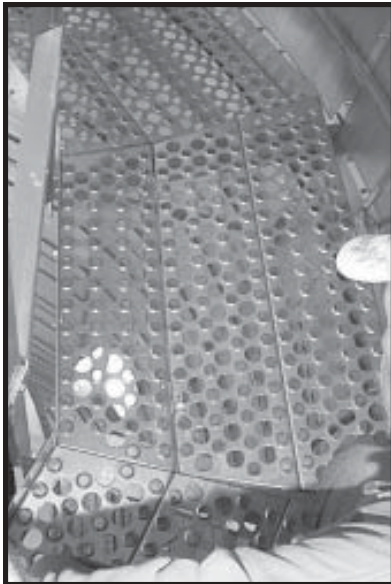

Photo 8-25 View from above - Inside Catwalk Door closed



Photo 8-26 View from above - Inside Catwalk Door open.



Photo 8-27 View from below - Inside Catwalk installed. (Inside Catwalk Door is closed.) (Ladder is not complete.)



Photo 8-28 View from below - Inside Catwalk installed. (Inside Catwalk Door is open.)

8.3. Platforms.

See Flat Layouts in Chapter 1, “Orientation” for placement of Platforms.

See Illustration 8-3, “Platform.”



Use 5/16” x 3/4” whiz lock bolts and nuts.

8.3.1. For each Platform, install two sections of catwalk flooring (with toeboards, diagonal supports, vertical supports, and handrails.)

8.3.2. Bolt Entry Toeboard and End Toeboard to catwalk flooring.

8.3.3. Bolt additional Catwalk Vertical Support (at dryer) to Horizontal Catwalk Support.

8.3.4. Bolt (2) End Handrails between Catwalk Vertical Supports.

8.3.5. Bolt Entry Handrail Extension to Entry Toeboard.

8.3.6. Bolt (2) Entry Handrails to Entry Handrail Extension and Catwalk Vertical Support.

8.3.7. Bolt Safety Cage Hoops to Platform Entry Handrail Extensions.



Check that all connections are made, and bolts are tight.

Additional Parts

- (1) Entry Toeboard
- (1) End Toeboard
- (2) End Handrail
- (2) Entry Handrail
- (1) Handrail Extension



Important Safety Precautions:

Dryer has sharp edges. These sharp edges may cause serious injury. Use appropriate Personal Protective Equipment. Use proper lifting techniques.



See Chapter 1 “Orientation” for dryer dimensions, components, wall sheet guidelines, etc.
See Appendices for “Tools and Equipment”, “Hardware”, etc.

9. Inside Ladders

(4) Auxiliary Ladders Burner Housing Ladder

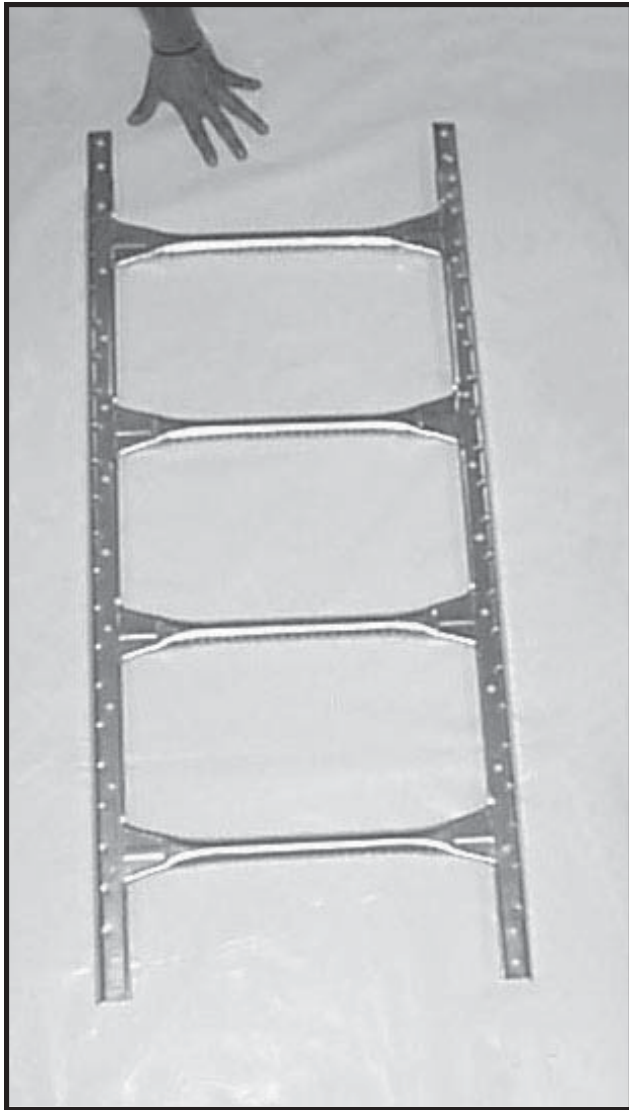

Photo 9-1 44" Formed Ladder Section.



Photo 9-2

- (1) Inside Ladder Standoff.
- (2) Outside Ladder Bracket
(only used on Outside Ladder).

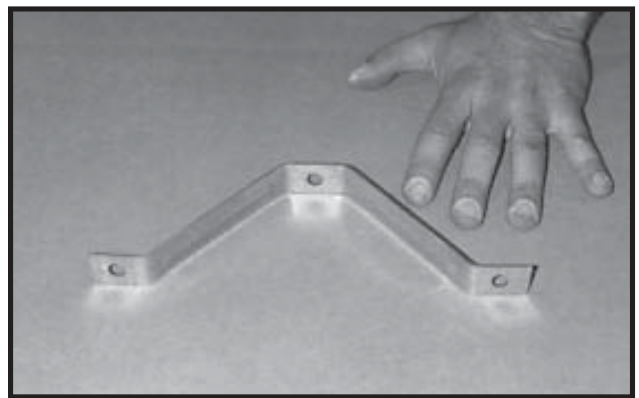

Photo 9-3 Close Up - Inside Ladder Standoff.

9.1. (4) Auxiliary Ladders

Install (4) Auxiliary Ladders to Inside Wall Sheets as follows.



Use existing 5/16" x 3/4" Whiz Lock bolts and nuts. **Double nut** with second 5/16" Whiz Lock nut.

9.1.1. Bolt first (2) Inside Ladder Standoffs on the horizontal seam between the Top Inside Wall Sheets. Start in 4th Bolt Hole left or right from edge of sheet. (Photo 9-5)

9.1.2. Bolt 4th bolt holes in 44" Formed Ladder Section to Inside Ladder Standoffs. (Photo 9-2)

9.1.3. Bolt next pair of Inside Ladder Standoffs on next horizontal seam down (directly below first pair). Join next 44" Formed Ladder Section to first and bolt to Inside Ladder Standoffs.

9.1.4. Install remaining (3) Auxiliary Ladders on every third Vertical Channel around inside wall of dryer.

9.1.5. Repeat steps to continue installing sections of (4) Auxiliary Ladders as dryer sections are completed.



Install all 44" Formed Ladder Sections so rungs with rough, textured side for gripping are on top, so climbers do not slip.

Placement of (4) Auxiliary Ladders.

Install first Auxiliary Ladder to left of same Vertical Channel as Outside Ladder (directly under Roof Access Port). First Auxiliary Ladder runs from Inside Top Wall Sheets, through Inside Catwalk, to Reducer Walkway.

Install remaining three Auxiliary Ladders on every third Vertical Channel. They run from Inside Top Wall Sheets to Inside Catwalk.

9.1. Auxiliary Ladder continued



Photo 9-4 Installing Auxiliary Ladder from roof section down.

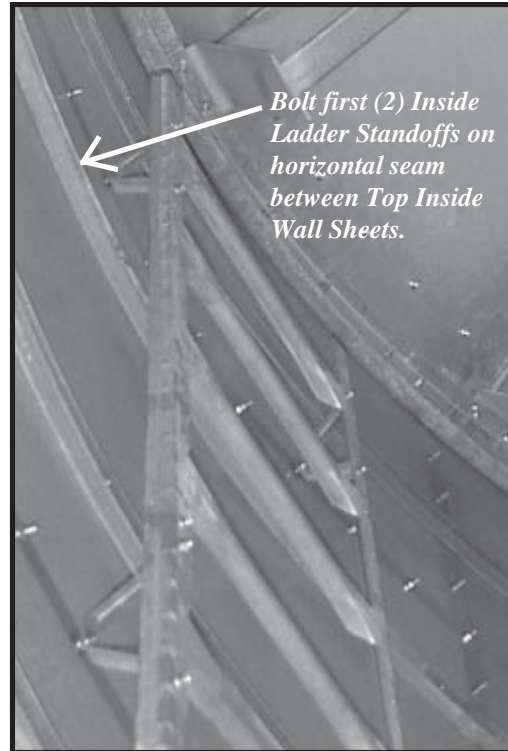

Bolt first (2) Inside Ladder Standoffs on horizontal seam between Top Inside Wall Sheets.

Photo 9-5 Close Up - Top of Auxiliary Ladder.



Photo 9-6 Installing first Auxiliary Ladder through Inside Catwalk.



Photo 9-7 Installing first Auxiliary Ladder past Slide Gates - Clean Out (Grain Turners).

9.1. Auxiliary Ladder continued

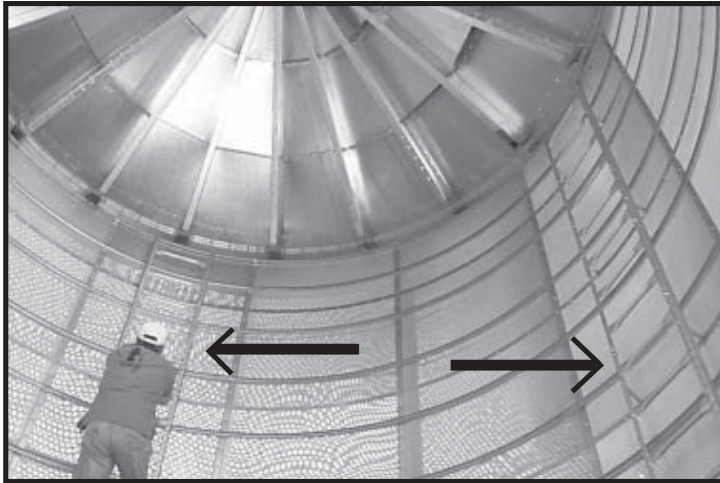

Photo 9-8 Auxiliary Ladders installed. (2 of 4 shown)





Photo 9-9



Photo 9-10.

9.2. (1) Burner Housing Ladder

-  Install Burner Housing Ladder after Reducer Walkway is complete.
-  Drill and use 5/16" x 3/4" Whiz Lock bolts and nuts.

9.2.1. Install (4) Inside ladder Standoffs to first 44" Formed Ladder Section as shown in Photos 9-11 and 9-12, then bolt it to Reducer Housing.

9.2.2. Install (4) Inside ladder Standoffs to second 44" Formed Ladder Section, join it to top of first 44" Formed Ladder Section, then bolt to Burner Housing.



Photo 9-11 Bolting Inside Ladder Standoff to 44" Formed Ladder Section.



Install all 44" Formed Ladder Sections so rungs with rough, textured side for gripping are on top, so climbers do not slip.

Placement of Burner Housing Ladder.



Burner Housing Ladder gives access to Burner. Check to be sure Burner Housing Ladder will top Burner Housing so it is centered on a corner of Burner. Avoid corner of Burner with pilot section.

Install Burner Housing Ladder so it is clear of Reducer Door.

9.2. Burner Housing Ladder continued



Photo 9-12 First 44" Formed Ladder Section installed to Reducer Housing.

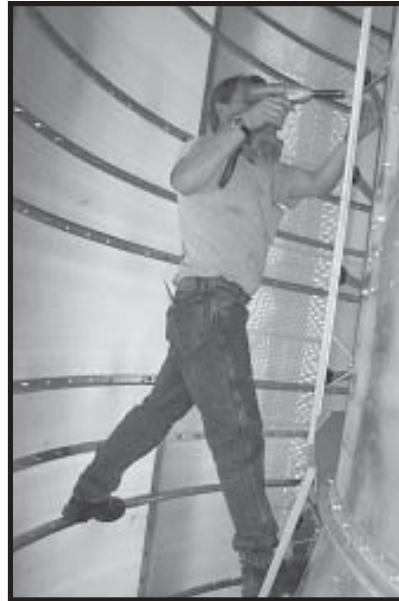

Photo 9-13 Bolting second 44" Formed Ladder Section to Burner Housing.



Photo 9-14 Installed Burner Housing Ladder.

**Important Safety Precautions:**

Dryer has sharp edges. These sharp edges may cause serious injury. Use appropriate Personal Protective Equipment. Use proper lifting techniques.



See Chapter 1 “Orientation” for dryer dimensions, components, wall sheet guidelines, etc. See Appendices for “Tools and Equipment”, “Hardware”, etc.

10. Slide Gates

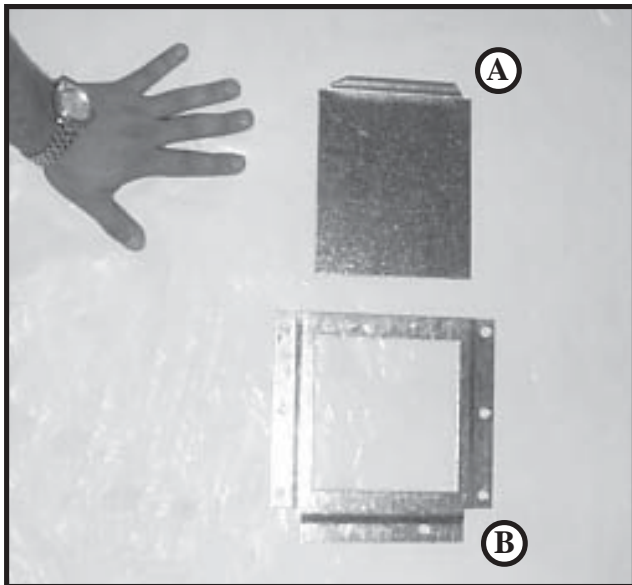

Photo 10-1

Use same Slide Gate parts for Grain Turner clean out and for emergency grain discharge at base of dryer.

(A) Slide Gate Plate

(B) Slide Gate Frame

10.1. Slide Gates (For Grain Turner clean out) (Photos 10-1 to 10-4)



After Inside Clean Out Wall Sheets with cutouts for Slide Gates are installed to dryer, install clean out Slide Gates.

10.1.1. Work from inside Dryer. Bolt Slide Gate Frame (with open end up), to each cutout in Inside Cleanout Wall Sheets.



Use 5/16" x 3/4" Whiz Lock bolts and nuts.



Install 5/16" x 3/4" truss head bolt (inserted into grain column) in bolt holes directly above Slide Gates. This allows insertion of Slide Gate Plates.

10.1.2. Insert Slide Gate Plate in each Slide Gate Frame.



Photo 10-2 Installing Slide Gate Frame to Inside Clean Out Wall Sheet. (For Grain Turner clean out.)

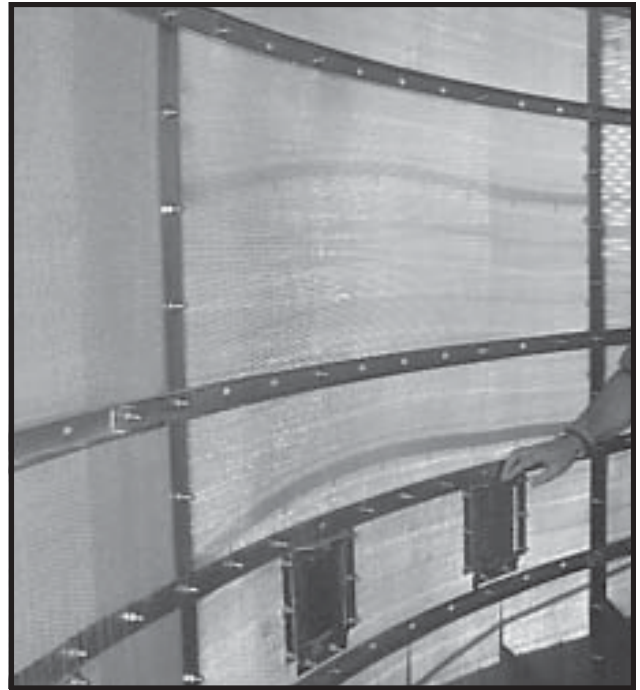

Photos 10-4 Slide Gates installed to Inside Clean Out Wall Sheets. (For Grain Turner clean out.)

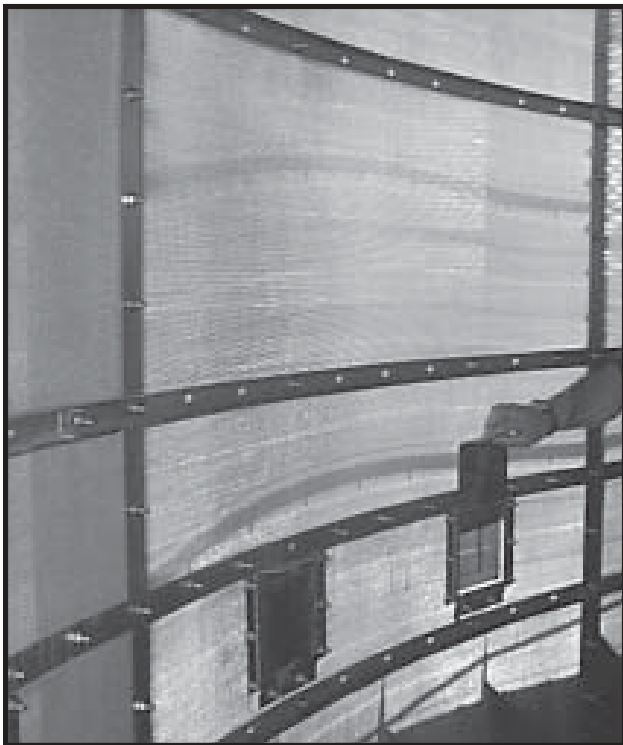

Photos 10-3 Inserting Slide Gate Plates in Slide Gate Frames on Inside Clean Out Wall Sheets. (For Grain Turner clean out.)

10.2. Slide Gates at Base of Dryer
(For emergency grain discharge.)

10.2.1. After Outside Bottom Wall Sheets (20" solid with cutouts) are installed at base of dryer, install Slide Gates as in Step 10.1.

(Photos 10-5 to 10-6)

10.2.2. After Outside Hopper panels with cutouts are installed, install Slide Gates as in Step 10.1.

(Photos 10-7 to 10-8)



Photos 10-7 Installing Slide Gate Plate to frame on Outside Hopper Panels. (For emergency discharge.)



Photos 10-5 Installing Slide Gate Plate to frame on Outside Bottom Wall Sheet. (For emergency discharge.)



Photos 10-6 Slide Gate installed to Outside Bottom Wall Sheet. (For emergency discharge.)



Photos 10-8 Slide Gate installed to Outside Hopper Panels. (For emergency discharge.)

**Important Safety Precautions:**

Dryer has sharp edges. These sharp edges may cause serious injury. Use appropriate Personal Protective Equipment. Use proper lifting techniques.



See Chapter 1 "Orientation" for dryer dimensions, components, wall sheet guidelines, etc. See Appendices for "Tools and Equipment", "Hardware", etc.

11. Grain Turners

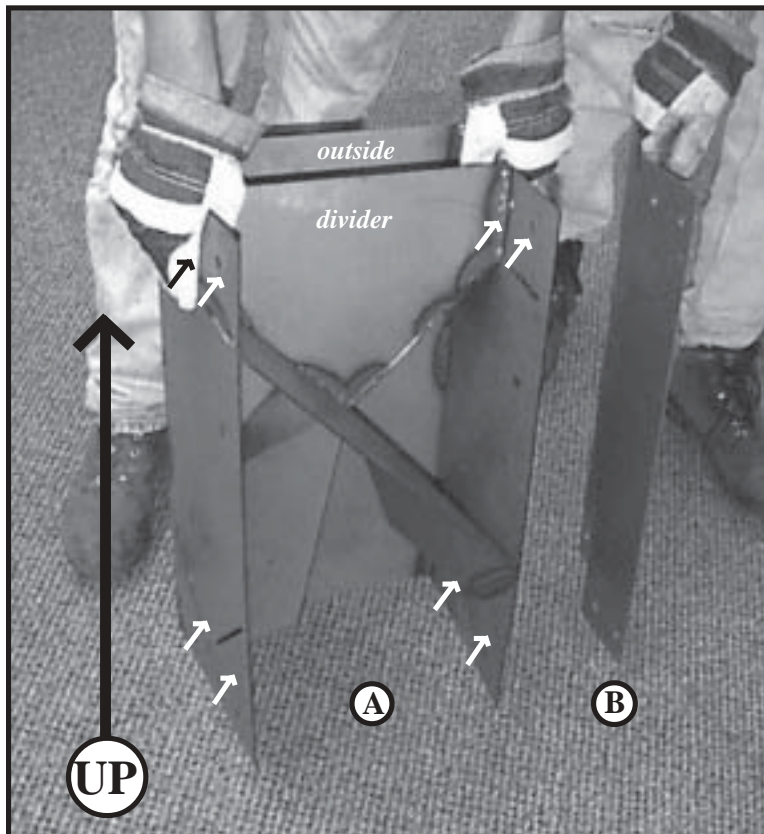

Photo 11-1

- (A) Grain Turner Section.
Install with *divider* edge up.
Install with *outside* of Grain Turner Section to outside of dryer.

Arrows indicate where Grain Turner Sections bolt to Vertical Channel, or to Grain Turner Offset Bracket, or to another Grain Turner Section.

- (B) Grain Turner Offset Bracket

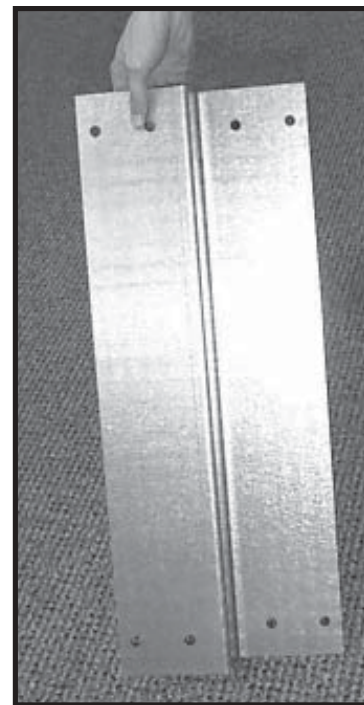

Photo 11-2 Close-Up - Grain Turner Offset Bracket.
(symmetrical - There is no up or down)

11. Grain Turners

Install (48) Grain Turner Sections with (12) Grain Turner Offset Brackets as follows.



(4) Grain Turner Sections are installed in each grain column make one Grain Turner.

Install after Inside Clean Out Sheets (for clean out Slide Gates) are installed.



Use 3/8" x 1" Hex Head bolts and nuts.

11.1. Bolt Grain Turner Offset Brackets inside Vertical Channels that face each other [].

Vertical Channels that face away from each other [] [] require no Grain Turner Offset Brackets.

11.2. In each grain column, loosely bolt (1) outside Grain Turner Section to each Vertical Channel (or to Grain Turner Offset Brackets).

Then loosely bolt (1) middle Grain Turner Sections to each outside Grain Turner Section.

Then loosely bolt (2) middle Grain Turner Sections together.



11.3. Tighten Grain Turners after all Grain Turner Sections are installed around dryer.

11.4. Test tightness by firmly tugging Grain Turners.

11.5. Install (2) rows Outside Wall Sheets (20" solid) over Grain Turners.



Photo 11-3 Installing outside Grain Turner Sections.



Photo 11-4 Installing middle Grain Turner Sections.



Photo 11-5 Tightening Grain Turner Sections.



Photo 11-6 Installed Grain Turners.

Burner 12 & Reducer

Illustration 12-1
Burner Housing
Model 2500/3000/3500

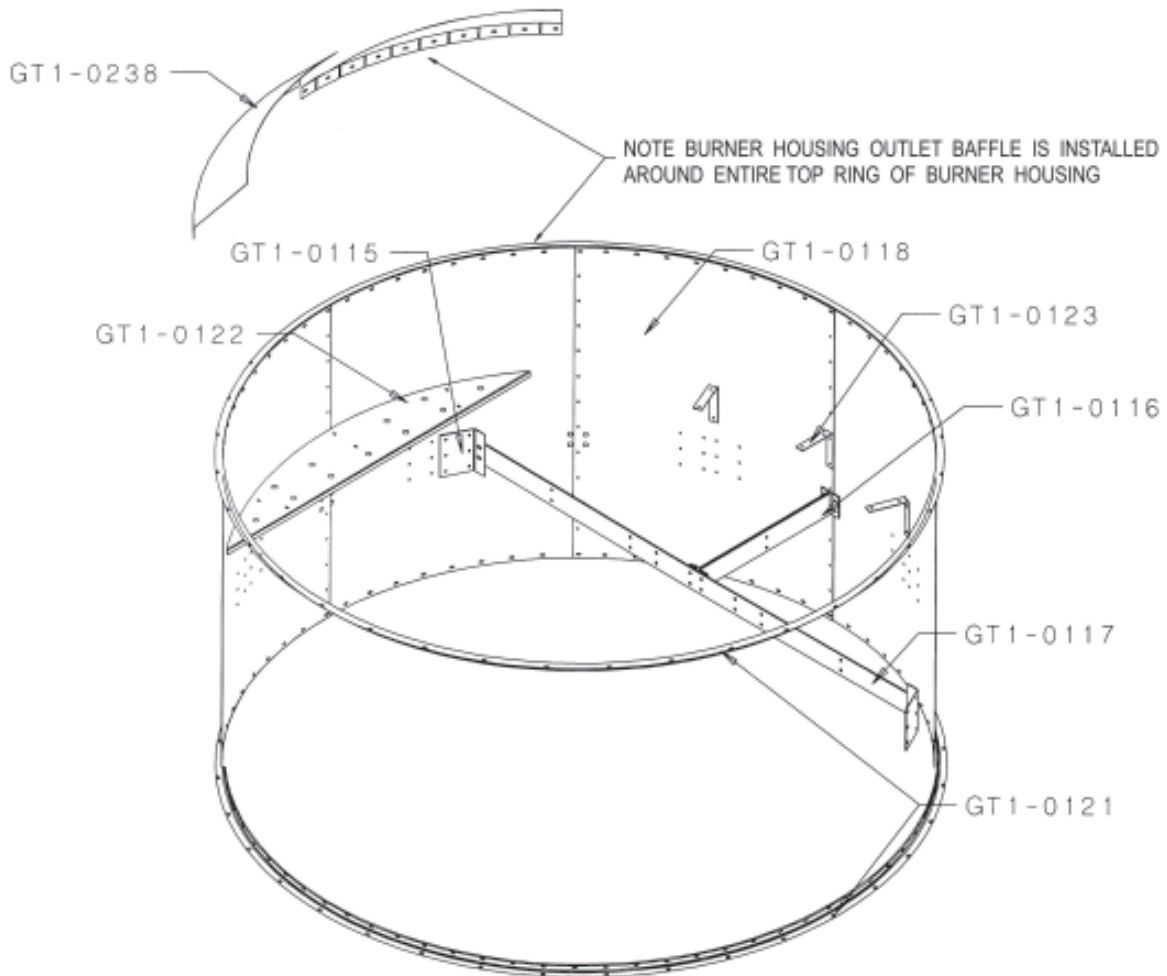

PART NO.	DESCRIPTION	QTY
GT1-0115	BURNER MOUNTING BRACKET	4
GT1-0116	BURNER SUPPORT TEE	4
GT1-0117	BURNER SUPPORT BRACKET	4
GT1-0118	BURNER HOUSING SHEET	8
GT1-0121	BURNER ANGLE RINGS	3
GT1-0122	BURNER BAFFLE	4
GT1-0123	BURNER BAFFLE SUPPORT	12
GT1-0238	BURNER HOUSING OUTLET BAFFLE	8

Illustration 12-2
Burner Housing
Model 4000

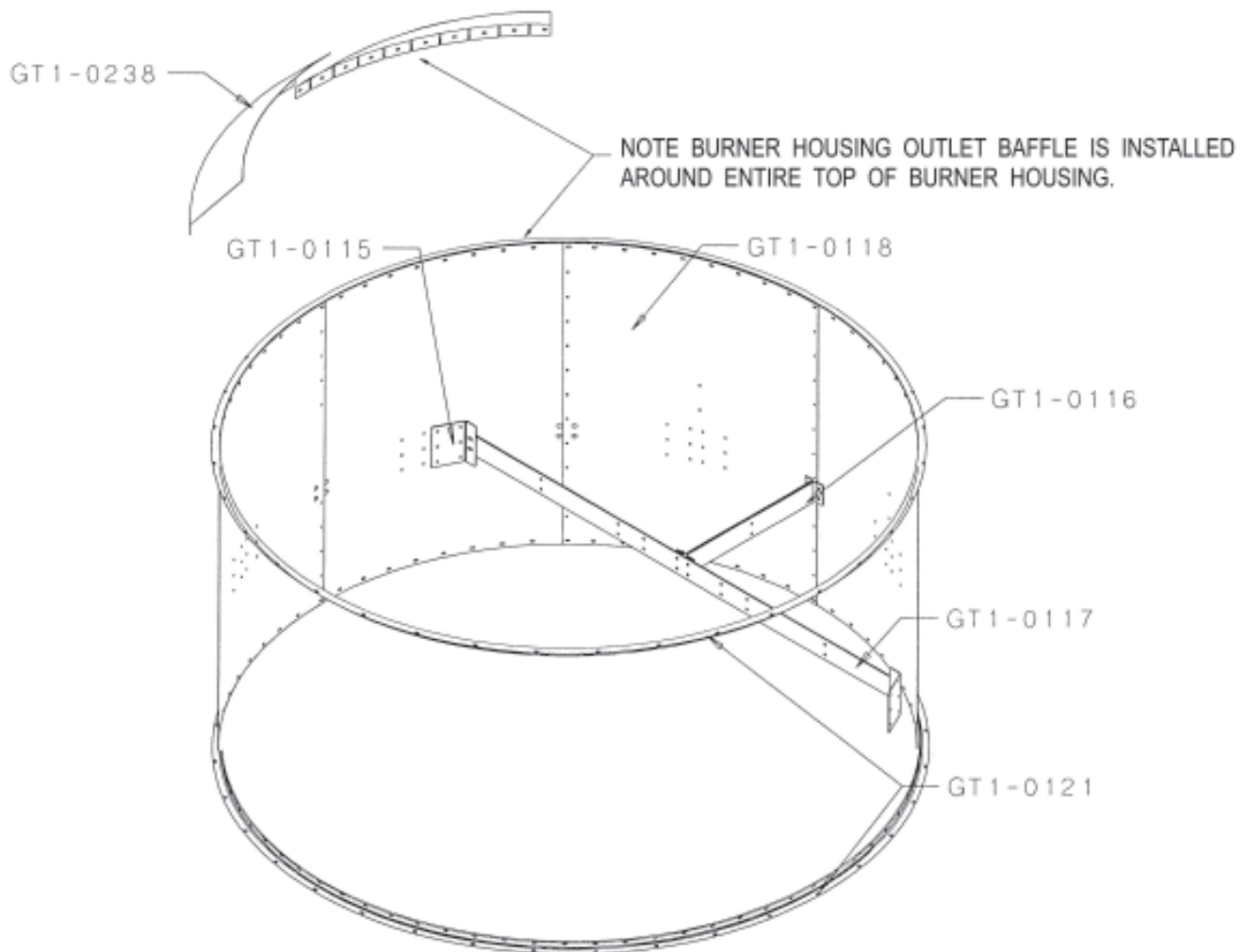

PART NO	DESCRIPTION	QTY
GT1-0115	BURNER MOUNTING BRACKET	4
GT1-0116	BURNER SUPPORT TEE	4
GT1-0117	BURNER SUPPORT BRACKET	4
GT1-0118	BURNER HOUSING SHEET	8
GT1-0121	BURNER ANGLE RINGS	3
GT1-0238	BURNER HOUSING OUTLET BAFFLE	8

**Important Safety Precautions:**

Dryer has sharp edges. These sharp edges may cause serious injury. Use appropriate Personal Protective Equipment. Use proper lifting techniques.



See Chapter 1 “Orientation” for dryer dimensions, components, wall sheet guidelines, etc. See Appendices for “Tools and Equipment”, “Hardware”, etc.

12. Burner & Reducer Example: Model 3000

12.1. Burner & Burner Housing.

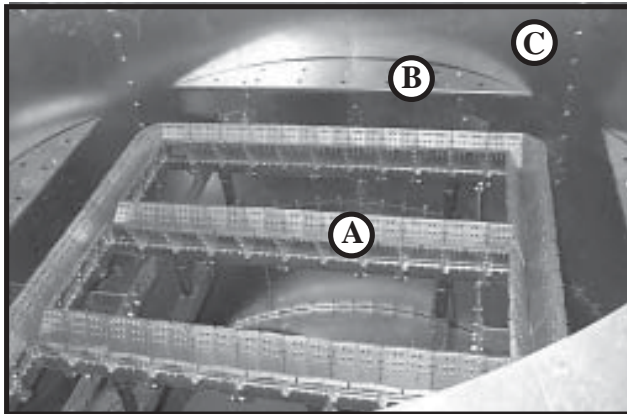

Photo 12-1 Burner installed inside Burner Housing.

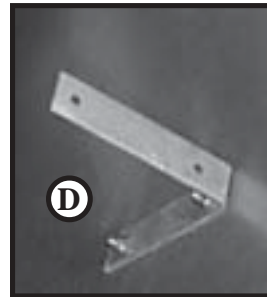

Photo 12-2



Photo 12-3



Burner Housing is straight vertical. Reducer is cone shaped to reduce air flow from Blowers to Burner Housing.

(Photos 12-1 to 12-4)

- (A) Burner
- (B) Burner Baffle
- (C) Burner Housing
- (D) Burner Baffle Support
- (E) Burner Housing Outlet Baffle
- (F) Burner Support Bracket
- (G) Burner Support Tee
- (H) Burner Mounting Bracket

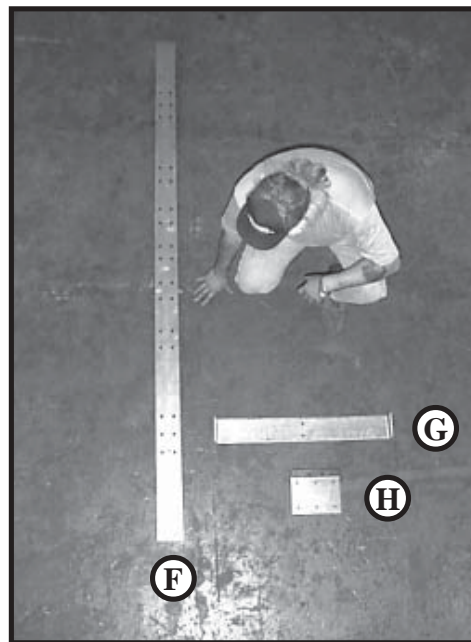

Photo 12-4



Photo 12-5 Install Rolled Plenum Channels across gap to maintain shape and stability. Remove Rolled Plenum Channels when ready to move burner into dryer.

12.1. Burner & Burner Housing

Depending on model, see Illustration 12-1 or 12-2, “Burner Housing”.

See Chapter 1, “Flat Layout” for Heat Section Door Frame Placement.

See Chapter 16, “Windows and Doors” for Heat Section Door and Reducer Door installation.

- 12.1.1. Remove Rolled Plenum Channels and bring in both halves of Burner Housing. See illustration for up/down orientation.

Also place Burner, Burner Baffle, and other parts inside Burner Housing to avoid lifting them in later. (Other parts are Burner Baffle Supports, Burner Mounting Brackets, Burner Support Brackets, and Burner Support Tees).

- 12.1.2.  Align and bolt halves of Burner Housing. Use 5/16” x 1” whiz lock bolts and nuts.

- 12.1.3.  Overlap and bolt sections of Burner Housing Outlet Baffle to top ring of Burner Housing. Use 5/16” x 1” whiz lock bolts and nuts.

- 12.1.4.  Check orientation of Burner pilot section (with installation points for Ignitor and Flame Sensor). Plan to install Burner so pilot section wiring will make direct run (usually through Motor Window to Control Box).

- 12.1.5. Measure to determine correct bolt hole knock-outs for Burner support parts. Knock out bolt holes as required.

- 12.1.6. Install Burner to Burner Housing as follows.

- 12.1.6.1.  Loosely bolt (4) Burner Mounting Brackets to Burner Housing. Bracket them (orient as mirror images). Use 3/8” x 1” bolts, nuts. Install washers on outside of Burner Housing.

- 12.1.6.2. Lift and temporarily support Burner while installing Burner Support Brackets below Burner.

- 12.1.6.2.  Loosely bolt (2) Burner Support Brackets to Burner Mounting Brackets. Use 1/2 x 1-1/2” bolts and nuts. Position Burner over Burner Support Brackets.

- 12.1.6.3.  Loosely bolt pairs of Burner Support Tees (back to back) to Burner Housing. Use 1/2” x 1-1/2” bolts, nuts. Install washers on outside of Burner Housing.

- 12.1.6.3.  Loosely bolt Burner Support Tees to Burner Support Brackets. Use 1/2” x 1” bolts and nuts.

- 12.1.6.4.  Bolt Burner Support Clips (already on Burner manifold) to Burner Support Brackets. Use 1/2” x 1” bolts and nuts.

12.1. Burner & Burner Housing continued

12.1.6.5. Tighten all bolts.

12.1.7. Models 2500/3000/3500.

 Bolt Burner Baffle Supports to Burner Housing. Bolt Burner Baffles to Burner Baffle Supports. Use 5/16" x 3/4" bolts and nuts.

 Fuel Piping will be installed in later step.

 After Reducer Walkway is installed, 44" Ladder Sections will be installed to outside of Burner Housing and Reducer.



Photo 12-7 Bolting together halves of Burner Housing.



Photo 12-6 Moving Burner, Burner Baffles and other parts inside Burner Housing.



Photo 12-8 Installing Burner Housing Outlet Baffle to top rim of Burner Housing.



Photo 12-9 Close up inside Burner Housing - Installing Burner Housing Outlet Baffle to top rim of Burner Housing.

12.1. Burner & Burner Housing continued



Photo 12-10 Measuring to determine correct knock-outs for bolt holes.



Photo 12-11 Knocking out bolt holes for Burner Mounting Bracket.



Photo 12-12 View inside Burner Housing - Installing Burner Mounting Bracket.



Photo 12-13 View outside Burner Housing - Installing Burner Mounting Bracket with washers.

12.1. Burner & Burner Housing continued

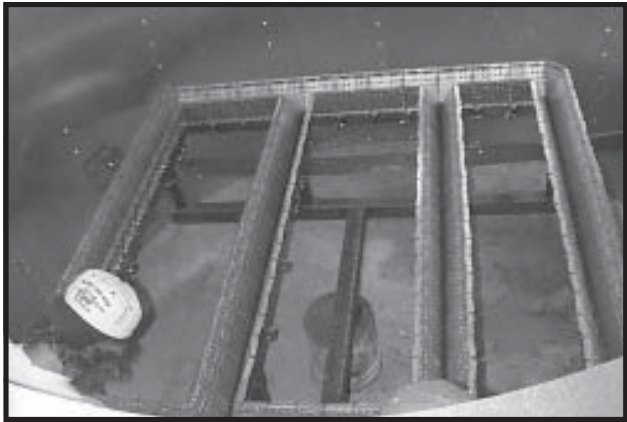

Photo 12-14 First Burner Support Bracket installed to Burner Mounting Brackets.



Photo 12-15 Installing second Burner Support Bracket to Burner Mounting Brackets.



Photo 12-16 Close up - Installing Burner Support Bracket to Burner Mounting Bracket.



Photo 12-17 Installing a pair of Burner Support Tees (back to back) to Burner Housing.

12.1. Burner & Burner Housing continued

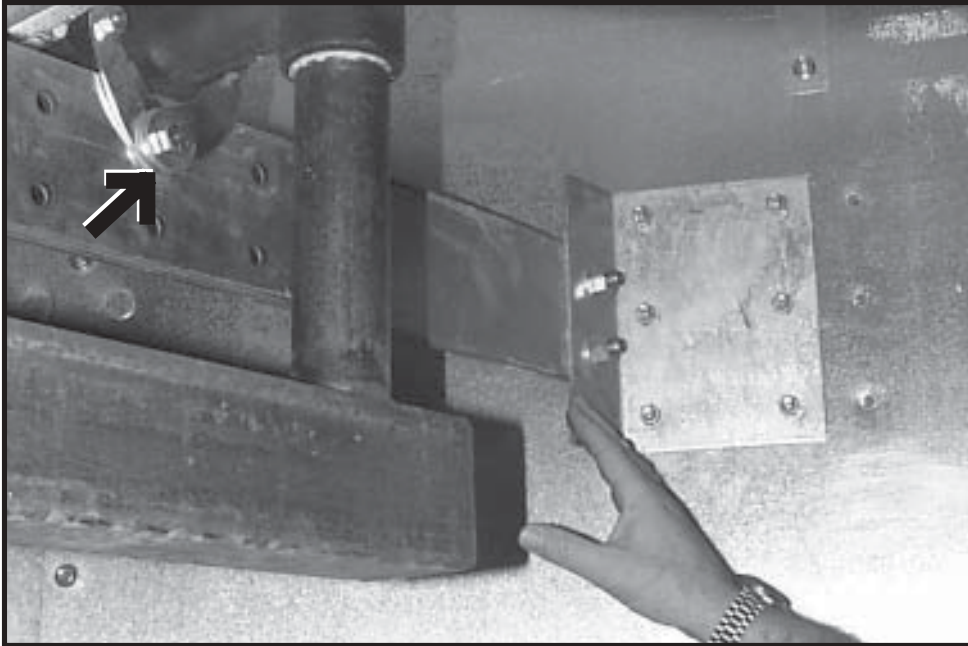

Photo 12-18 Burner Support Bracket bolted to Burner Support Clip (arrow).



Photo 12-19 Installing Burner Baffle Supports.



Photo 12-20 Installing Burner Baffles.

12.2. Reducer.

12.2.1. Lift Burner/Burner Housing. Move both halves of Reducer into dryer and under Burner Housing.

✓ **Orient Reducer Door Cutout so it faces same Vertical Channel as Heat Section Burner Door. This will ensure maximum light for entering completed Reducer area.**

On completed dryer, Burner will be accessed through Reducer Door. Orient pre-cut opening for Reducer Door so it will give easy access to Reducer by stepping onto top of a Fan or Fan Splicing.

12.2.2. Bolt side seams of Reducer.
 🔧 Use 5/16" x 1" whiz lock bolts and nuts.

Align and bolt Reducer to Burner Housing.

Lift Reducer 1" or 2" and bolt together bottom rim of Reducer halves.



Photo 12-22 Move Reducer under Burner Housing.



Photo 12-23 Orient Reducer Door Cutout so it faces same Vertical Channel as Heat Section Burner Door.



Photo 12-21 Remove Rolled Plenum Channels, and lift Burner/Burner Housing to provide access for Reducer.



Photo 12-24 Bolting halves of Reducer together.

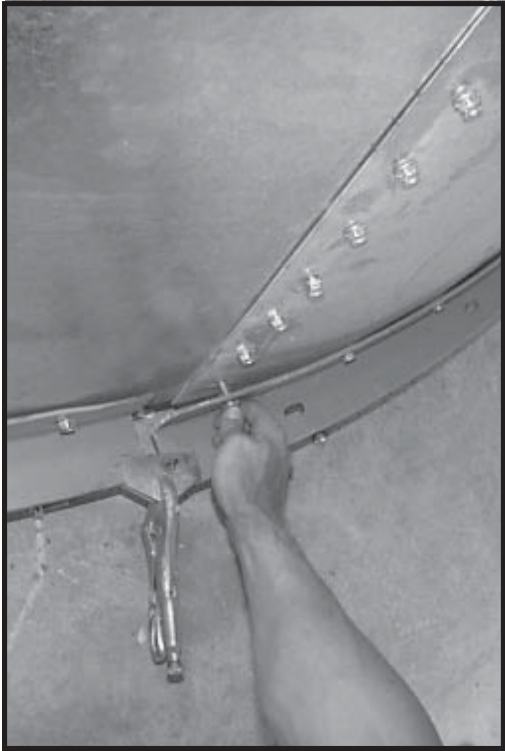

Photo 12-25 Close up - Bolting halves of Reducer Ring together.



Photo 12-26 Aligning and bolting Reducer to Burner Housing.

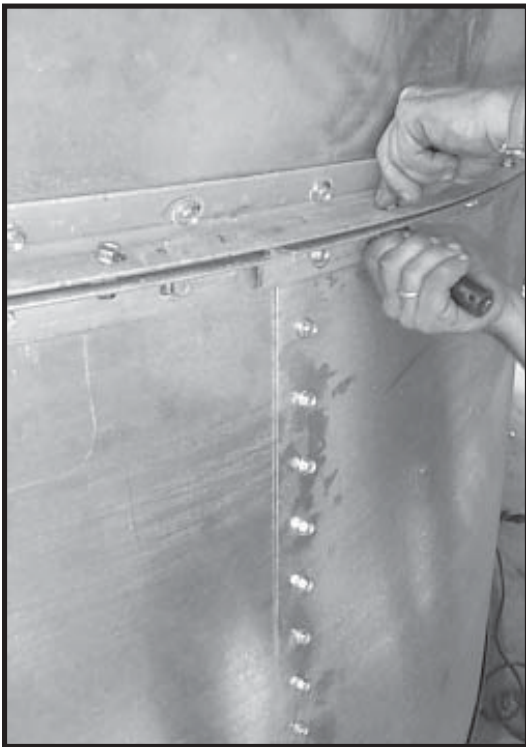
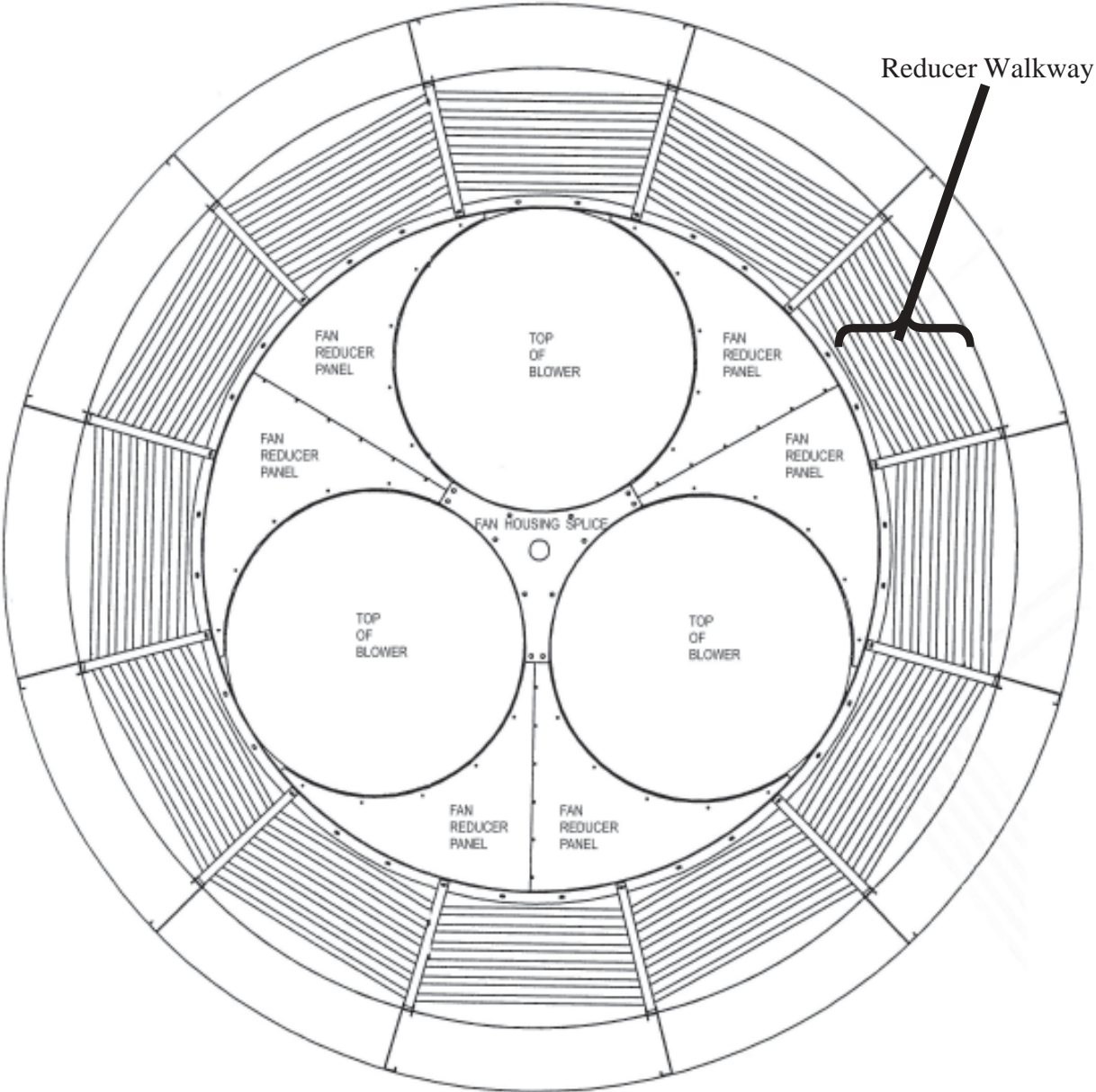

Photo 12-27 Close up - bolting Reducer to Burner Housing.

Fans Divider Hopper Reducer Walkway **13**

Illustration 13-1
Fan Splicing
Example - All Models



13 Fans
Divider Hopper
Reducer Walkway

18' Tower Dryer Construction

Illustration 13-2

Fan X-Bracing Clips
All Models

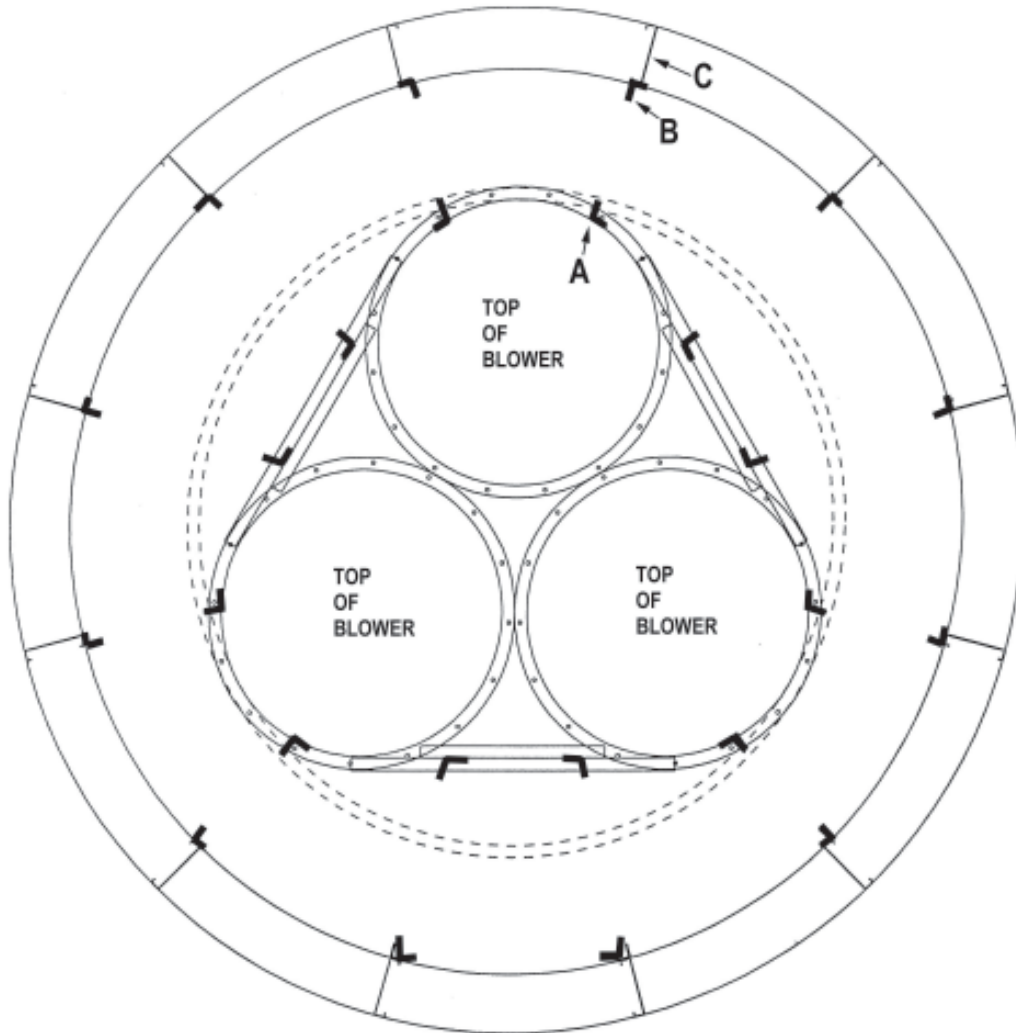

A = FAN CROSSBEAM CLIPS

B = FAN SUPPORT CLIPS

C = VERTICAL CHANNELS

Note orientation of A to B.

Illustration 13-3
Fan X-Bracing
All Models

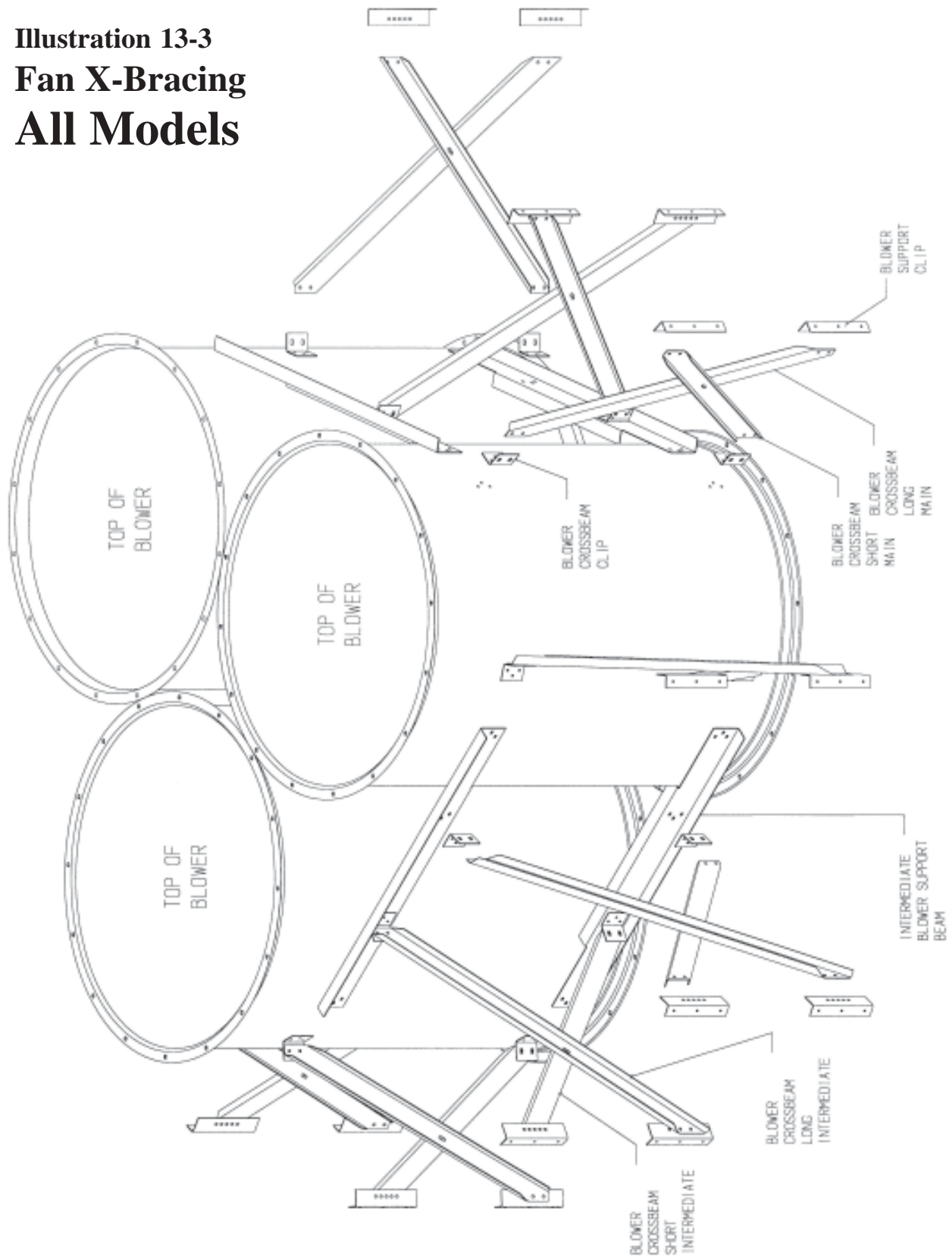

13 Fans
 Divider Hopper
 Reducer Walkway

18' Tower Dryer Construction

Illustration 13-4

Fan X-Bracing, Divider Hopper, & Reducer Walkway
 Model 2500

PART NO.	DESCRIPTION	QTY
GT1-0130	REDUCER WALKWAY SUPPORT CLIP	12
GT1-0131	REDUCER WALKWAY SUPPORT BEAM 445	12
GT1-0154	BLOWER SKIRTING 445	4
GT1-0165	OUTER DIVIDER HOPPER	12
GT1-0166	INNER DIVIDER HOPPER 445	12
GT1-0185	BLOWER SUPPORT CLIP	24
GT1-0186	BLOWER CROSSBEAM CLIP	24
GT1-0187	BLOWER CROSSBEAM SHORT MAIN 445	6
GT1-0188	BLOWER CROSSBEAM LONG MAIN 445	6
GT1-0189	INTERMEDIATE BLOWER SUPPORT BEAM 445	6
GT1-0190	BLOWER CROSSBEAM SHORT INTERMEDIATE 445	6
GT1-0191	BLOWER CROSSBEAM LONG INTERMEDIATE 445	6

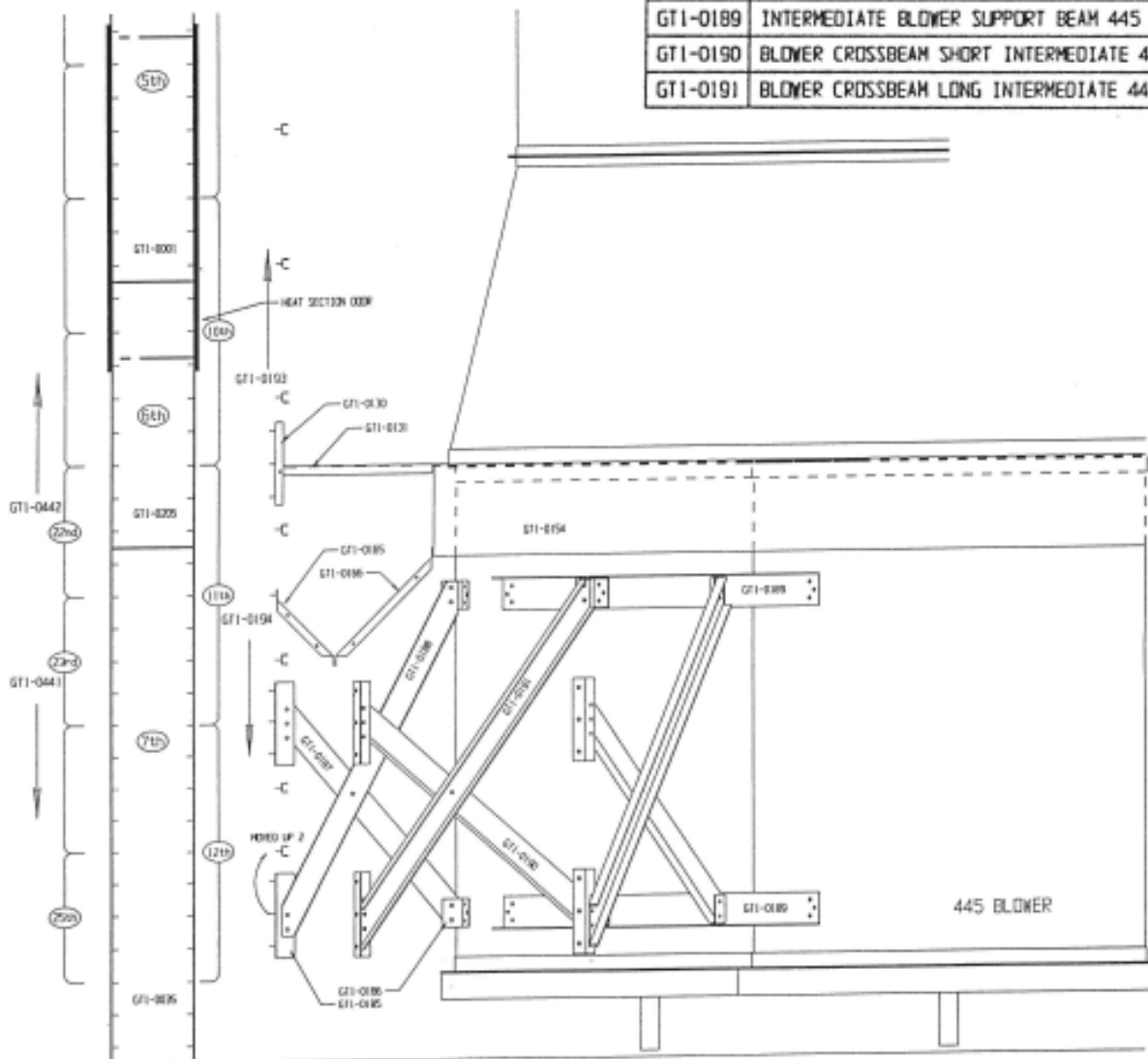
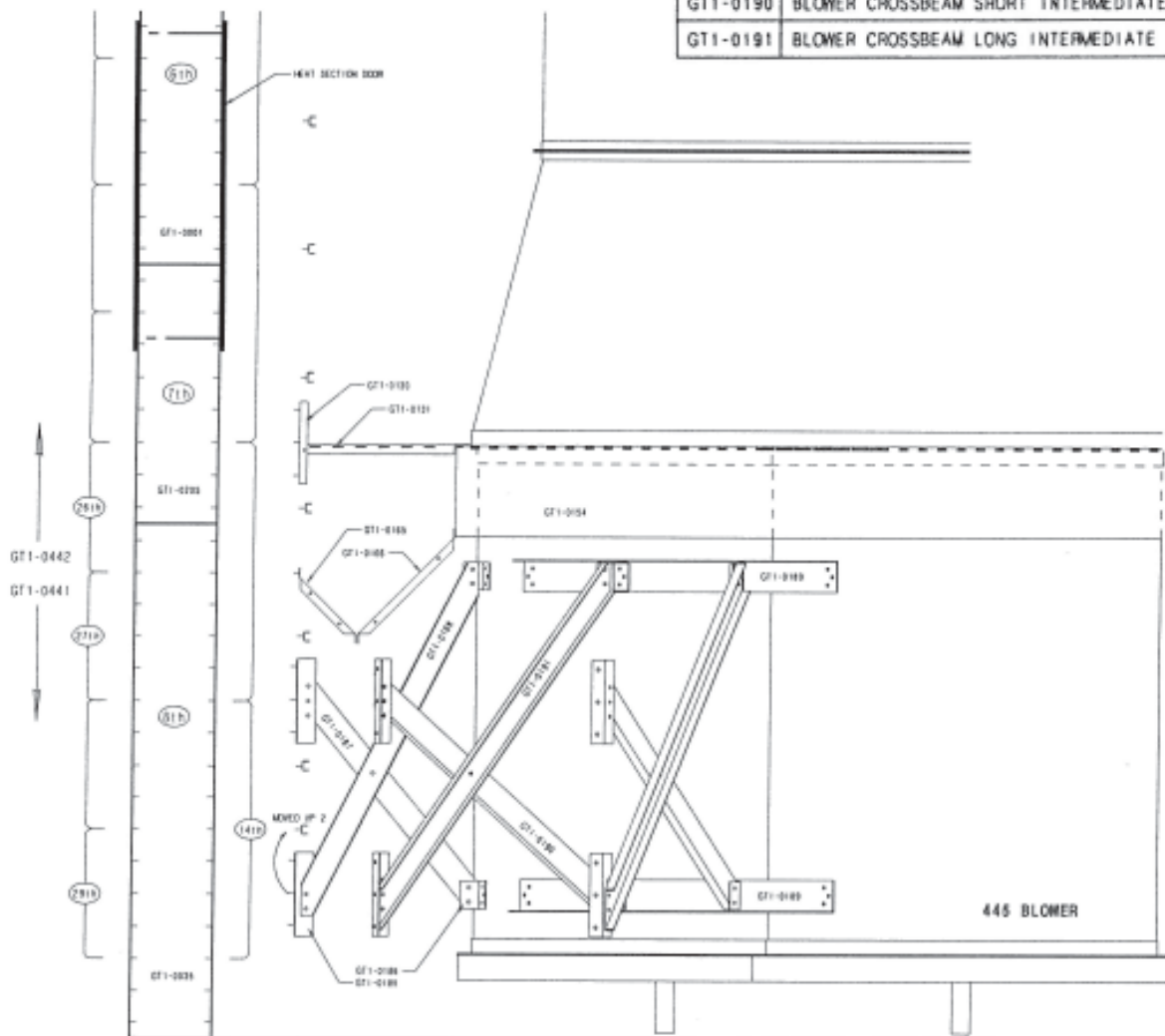

Illustration 13-5

Fan X-Bracing, Divider Hopper, & Reducer Walkway
 Model 3000

PART NO	DESCRIPTION	QTY
GT1-0130	REDUCER WALKWAY SUPPORT CLIP	12
GT1-0131	REDUCER WALKWAY SUPPORT BEAM 445	12
GT1-0154	BLOWER SKIRTING 445	4
GT1-0165	OUTER DIVIDER HOPPER	12
GT1-0166	INNER DIVIDER HOPPER 445	12
GT1-0185	BLOWER SUPPORT CLIP	24
GT1-0186	BLOWER CROSSBEAM CLIP	24
GT1-0187	BLOWER CROSSBEAM SHORT MAIN 445	6
GT1-0188	BLOWER CROSSBEAM LONG MAIN 445	6
GT1-0189	INTERMEDIATE BLOWER SUPPORT BEAM 445	6
GT1-0190	BLOWER CROSSBEAM SHORT INTERMEDIATE 445	6
GT1-0191	BLOWER CROSSBEAM LONG INTERMEDIATE 445	6



13 Fans
 Divider Hopper
 Reducer Walkway

18' Tower Dryer Construction

Illustration 13-6

Fan X-Bracing, Divider Hopper, & Reducer Walkway
 Model 3500

PART NO.	DESCRIPTION	QTY
GT1-0130	REDUCER WALKWAY SUPPORT CLIP	12
GT1-0165	OUTER DIVIDER HOPPER	12
GT1-0185	BLOWER SUPPORT CLIP	24
GT1-0186	BLOWER CROSSBEAM CLIP	24
GT1-0206	INNER DIVIDER HOPPER 490	12
GT1-0211	BLOWER SKIRTING 490	6
GT1-0218	REDUCER WALKWAY SUPPORT BEAM 490	12
GT1-0230	BLOWER CROSSBEAM SHORT MAIN 490	6
GT1-0231	BLOWER CROSSBEAM LONG MAIN 490	6
GT1-0232	BLOWER INTERMEDIATE SUPPORT BEAM 490	6
GT1-0233	BLOWER CROSS BEAM SHORT INTERMEDIATE 490	6
GT1-0234	BLOWER CROSSBEAM LONG INTERMEDIATE 490	6

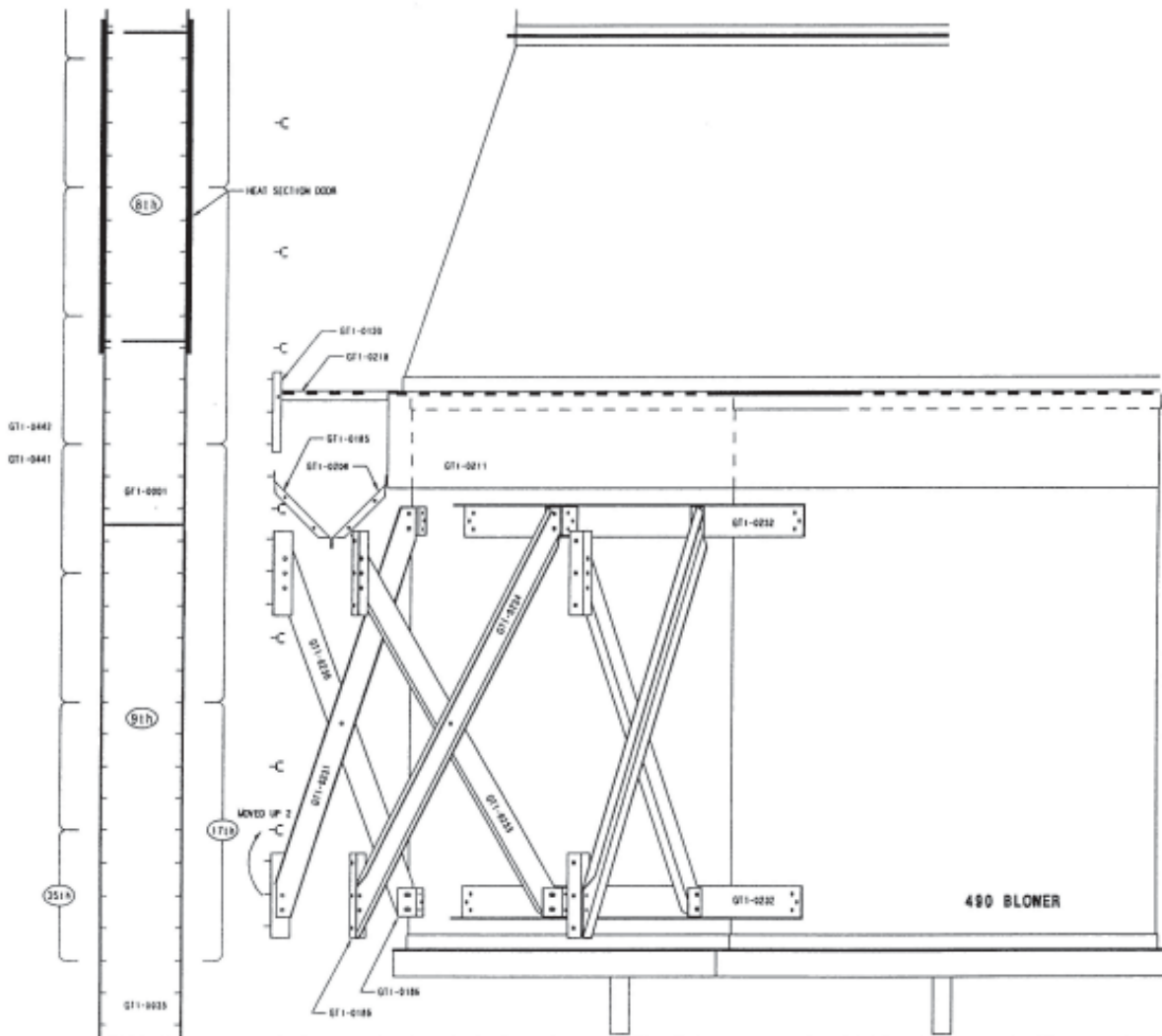



Important Safety Precautions:

Dryer has sharp edges. These sharp edges may cause serious injury. Use appropriate Personal Protective Equipment. Use proper lifting techniques.



See Chapter 1 “Orientation” for dryer dimensions, components, wall sheet guidelines, etc. See Appendices for “Tools and Equipment”, “Hardware”, etc.

13. Fans (3), Divider Hopper, Reducer Walkway

Fan Parts

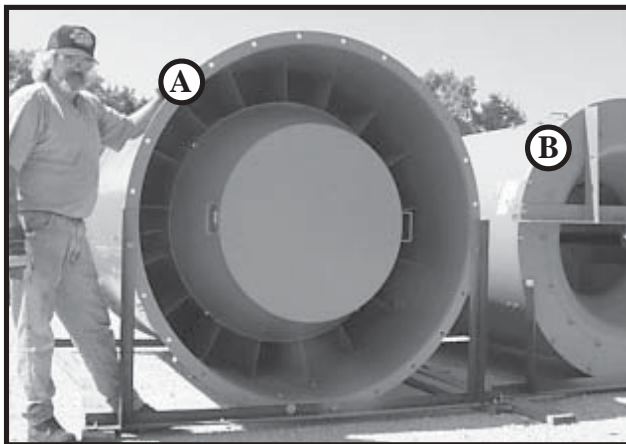

Photo 13-1 Fan (centrifugal fans).
Top View of Fan A.

(A) 490 Fan (3500 bph and 4000 bph dryers).

(B) 445 Fan (2500 bph and 3000 bph dryers).

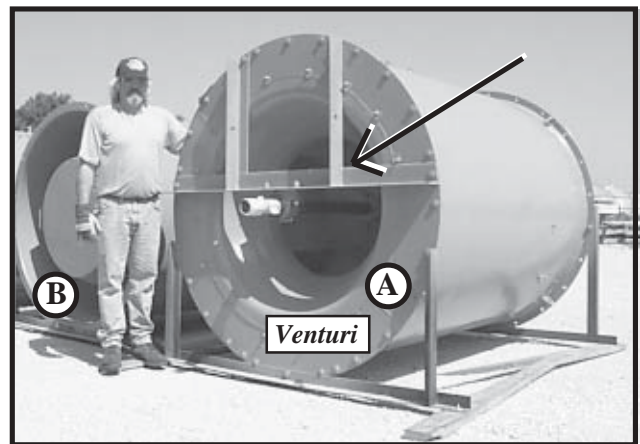

Photo 13-2 Bottom View of Fan A.

Motor Mount Angles - pre-installed at factory (arrow).

Venturi - is the curved inside wall of Fan.



Photo 13-3 Fan Housing Splice.

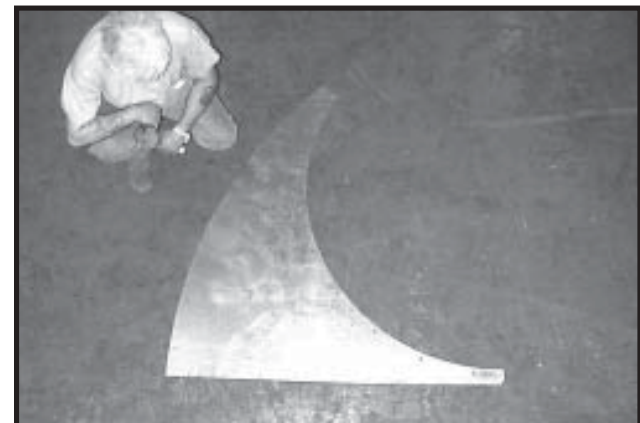

Photo 13-4 Fan Reducer Panel.

Fan Parts continued

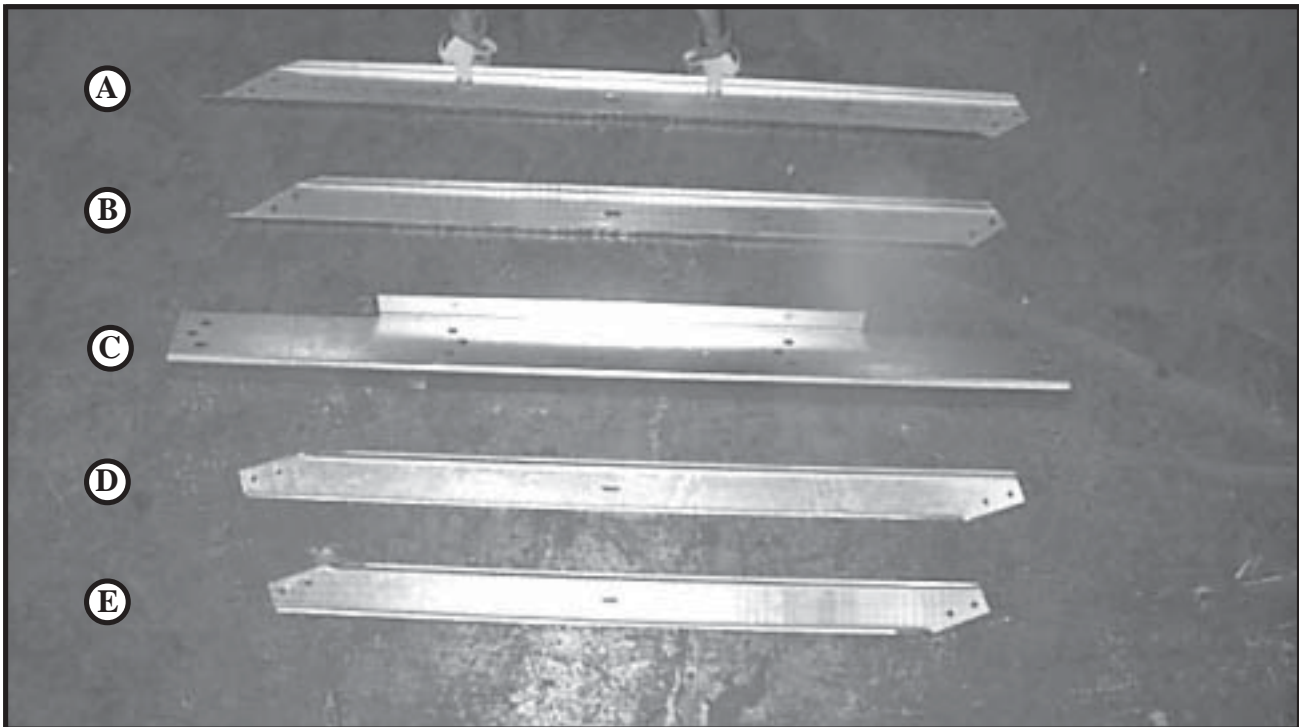

Photo 13-5

- (A) Fan Crossbeam Short Main
- (B) Fan Crossbeam Long Main
- (C) Intermediate Fan Support Beam

- (D) Fan Crossbeam Short Intermediate
- (E) Fan Crossbeam Long Intermediate

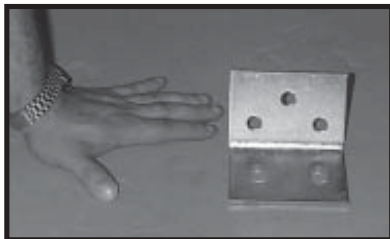

Photo 13-6
Fan Crossbeam Clip.

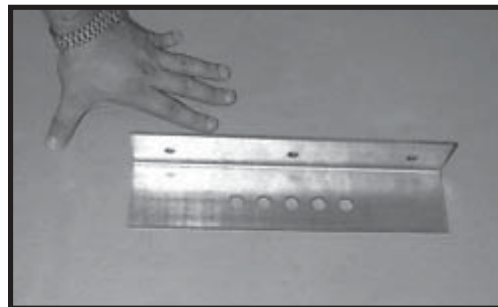

Photo 13-7
Fan Support Clip.

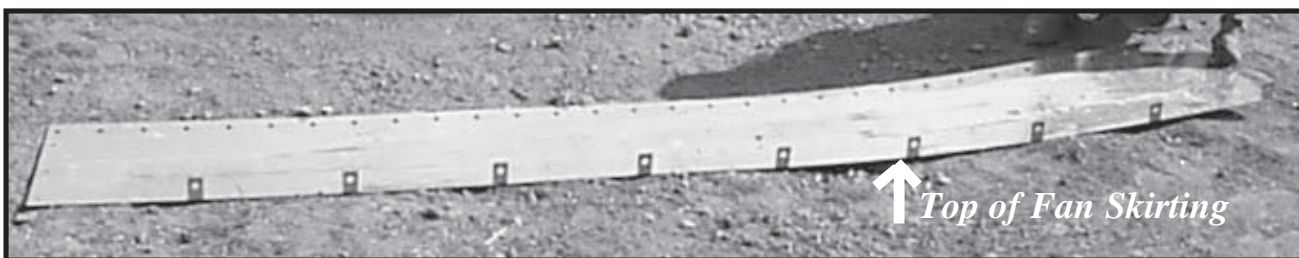



Photo 13-8 Fan Skirting section.

13.1. Move Fans into Dryer.

Lift Reducer/Burner to clear Fans and move all (3) Fans into dryer on moving dollies as follows.

 This is the beginning of Cool Section construction.

 Inside Ladder is not installed in Cool Section.

 Leave out bolts for Fan Support Clip in Vertical Channels as shown for your dryer model in Illustrations 13-4 to 13-7, "Fan X-Bracing..."

13.1.1. Remove tape from Fan Drive Shaft.

13.1.2. Remove Key from Fan Drive Shaft and save for later Motor Sheave and Belt installation.

13.1.3. Slide dolly on Fan Drive Shaft. Center it and tighten dolly bolts.  Check keyway is clear of bolts.

13.1.4. Attach lifting tackle to Fan Lift Eyelets. Lift Fan about 8".

 Check lifting tackle connections are secure.

13.1.5. Move all (3) Fans next to dryer. Stand Fans up vertical with Drive Shaft down on dolly.

13.1.6. Push Fans into dryer.

13.1.7. When all Fans are inside dryer, fill in Vertical Channel, Wall Sheets, and Rolled Plenum Channels.

13.1.8. Position three Fans inside dryer as follows.

- Fans form a cluster. To determine Fan cluster orientaton for your model, see Chapter 1 Illustation "Flat Layout" for your model.

Turn each Fan so that when Motor Mount is installed (in later step), each Fan Motor will be centered on an Inside Wall Sheet where free air windows will be installed. (Air draws over and cools Fan Motors.)

- Exactly center Fan cluster inside walls of dryer. (This allows installation of Divider Hopper between Fans and inside dryer walls in later step.)
- Adjust so top and bottom rings of Fans are level and touching.

13.1.9. Note position of upper Grease Zert on each Fan for installation of Grease Tube in later step.



Photo 13-9 Dolly - top.



Photo 13-10 Dolly - bottom.

13.1. Move Fans into Dryer continued



Photo 13-11 Checking clearance for Fan under Reducer/Burner.



Photo 13-12 Remove Fan Drive Shaft Key and save it.

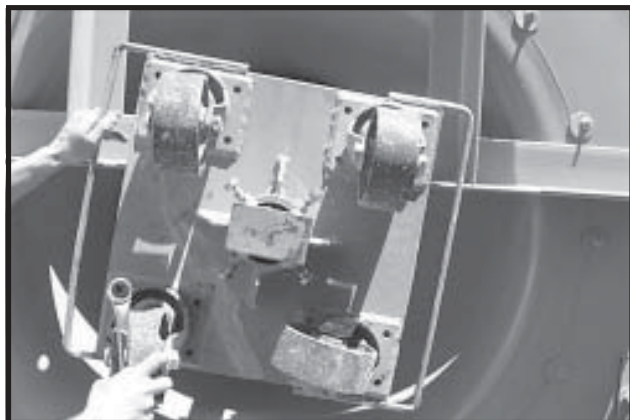

Photo 13-13 Dolly is bolted to Fan Drive Shaft.



Photo 13-14 Lifting tackle is attached to Fan Lift Eyelets.



Photo 13-15 Stand Fan up vertical with Drive Shaft down on dolly.



Photo 13-16 Close up - Fan with Drive Shaft down on dolly.

13.1. Move Fans into Dryer continued



Photo 13-17 Move Fans to dryer.



Photo 13-18 Pushing Fans into dryer.



Photo 13-19 Three Fans form a cluster inside dryer.



Photo 13-20 Re-installing Vertical Channel after Fans are inside dryer.

13.1. Move Blowers into Dryer continued

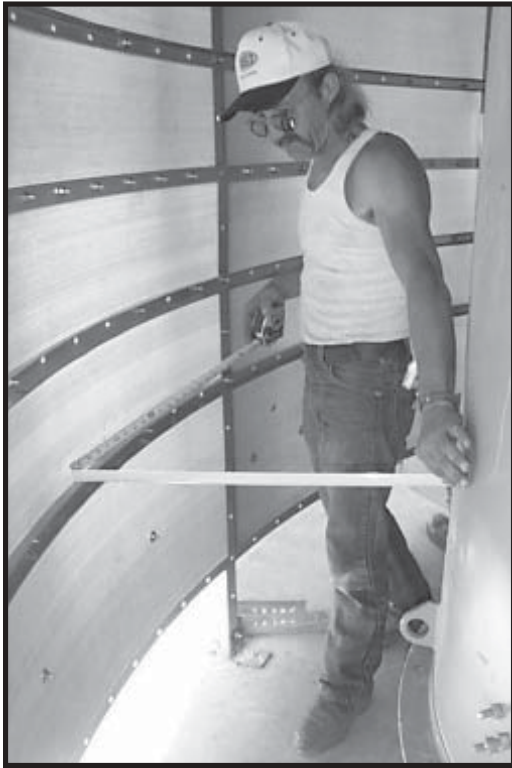

Photo 13-21 Measuring to exactly center Fan cluster inside walls of dryer.



Photo 13-22 Positioning Fans in a cluster with Top and Bottom rings level and touching.



Photo 13-23 Note location of upper Grease Zert for installation of Grease Tube in later step.



Photo 13-24 Close up - upper Grease Zert.

13.2. Splicing.

To close in space around Fans, install Fan Housing Splice and (6) Fan Reducer Panels as follows.

See Illustration 13-1, "Fan Splicing".

13.2.1. Lower Reducer/Burner down to top of Fans.

✓ Check lower ring of Reducer is centered over Fan cluster. Align lower Ring of Reducer with (2) outer bolt holes in top ring of each Fan.

✓ Check Fans are level.

✓ Check Reducer is exactly centered within inner wall of dryer.

13.2.2. Center Fan Housing Splice above Fan cluster, and bolt where it overlaps top rings of Fans.

🔧 Use 1/2" x 1" bolts and nuts with washer.

13.2.3. Bolt lower Ring of Reducer in (2) outer bolt holes in top ring of each Fan. Use 3/8" x 1" bolts and nuts with washer.**13.2.4.** Bolt Fan Reducer Panels to fill space around Fans as follows.

🔧 To bolt Fan Reducer Panels to top rings of Fans or bottom ring of Reducer, use 1/2" x 1" bolts and nuts with washer.

🔧 Where Fan Reducer Panels overlap, use 1/2" x 3/4" bolts and nuts with washer.



Photo 13-25 Bolting Fan Housing Splice, centered on top of Fan cluster.



Photo 13-26 Positioning Fan Reducer Panel.



Photo 13-27 Bolting Fan Reducer Panel.

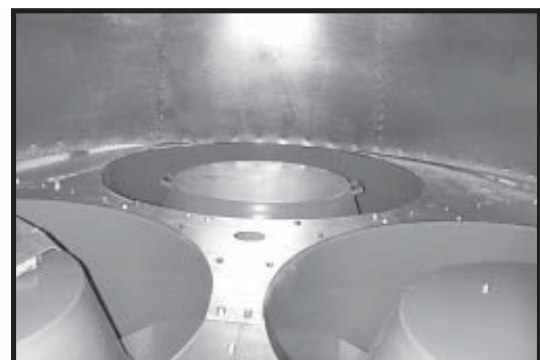



Photo 13-28 Fan Housing Splice installed.

13.3. X-Bracing.

X-Bracing forms an “X” between clips on Fans and clips on Vertical Channels. For placement of clips and X-Bracing, see Illustrations 13-4 to 13-7 for your dryer model.

 At this point, Reducer Walkway Support Clips can be installed to Inside Wall Sheets with existing bolts. Reducer Walkway is installed in later step.

13.3.1. Bolt (2) Fan Support Clips to each Vertical Channel. Use 3/8” x 1” bolts and 1/2” nuts.



13.3.2. Join each pair of Fans with (2) Intermediate Fan Support Beams. Use bolts and nuts that are already on Fans, add 1/2” washers.



13.3.3. Bolt Fan Crossbeam Clips to Fans and to Intermediate Fan Support Beams. Use 1/2” x 1” bolts and 1/2” nuts.



13.3.4. Bolt Fan Crossbeams (Short Main, Long Main, Short Intermediate, and Long Intermediate) to form “X” between Fan Support Clips and Fan Crossbeam Clips. Use 1/2” x 1” bolts and 1/2” nuts with washers.



Photo 13-30 Installing top Intermediate Fan Support Beam across (2) Fans.



Photo 13-31 Installing bottom Intermediate Fan Support Beam across (2) Fans.



Photo 13-29 Use existing bolts on Fans to install Intermediate Fan Support Beams and some Fan Cross Beam Clips.



Photo 13-32 Installing Fan Cross Beam Clip to Fan.

13.3. X-Bracing continued



Photo 13-33 Clips installed.

(A) Fan Support Clips

(B) Fan Crossbeam Clips

☞ (X) Reducer Walkway Support Clips can be installed at this point. Reducer Walkway is installed in later step.



Photo 13-34 Top of Fan - Installing Fan Crossbeam to Fan Crossbeam Clip.



Photo 13-35 LH view of Bracing installed to Fan Support Clip.

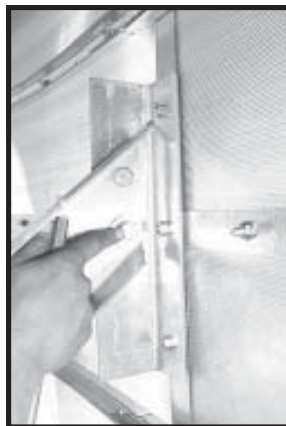

Photo 13-36 RH view of Bracing installed to Fan Support Clip.

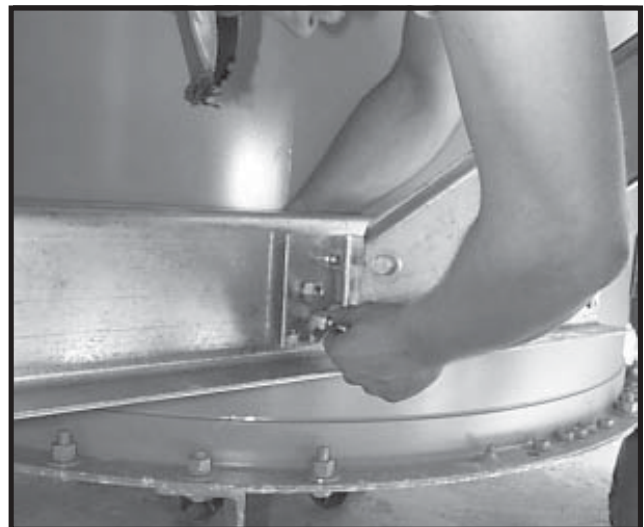

Photo 13-37 Bottom of Fan - Installing Fan Crossbeam to Fan Crossbeam Clip.

13.3. X-Bracing continued



Photo 13-38 X-Bracing installed.



Photo 13-39



Photo 13-40



Photo 13-41

13.4. Fan Skirting.

To install Fan Skirting sections around top of Fans, snug bolt widely spaced tabs on top of Fan Skirting sections to bottom ring of Reducer. Snug bolt Fan Skirting sections together. (Photo 13-43)



Leave Fan Skirting loose until after installing Reducer Walkway Support Beams.



Use 5/16" x 1" bolts and 1/2" nuts with washers.



Photo 13-42 Aligning Fan Skirting section to bottom ring of Reducer.

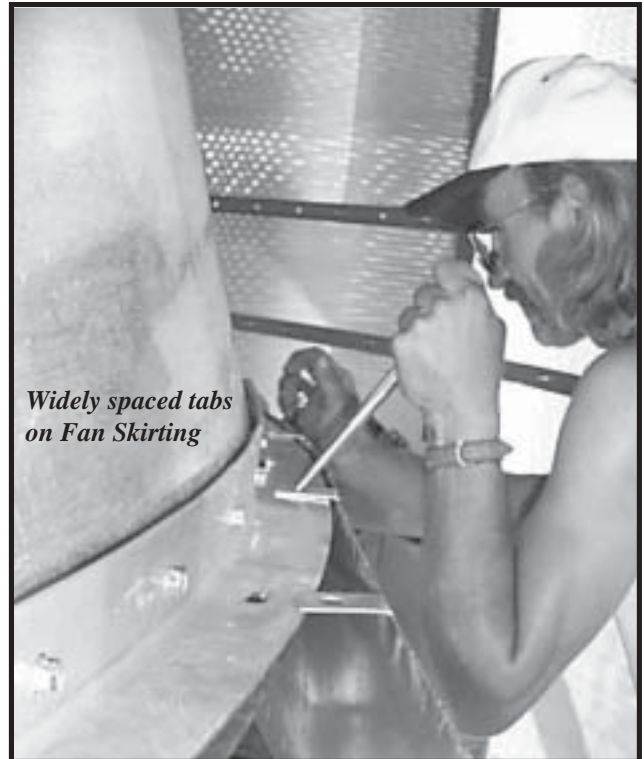

Photo 13-43 Bolting widely spaced tabs at top of Fan Skirting to bottom ring of Reducer.

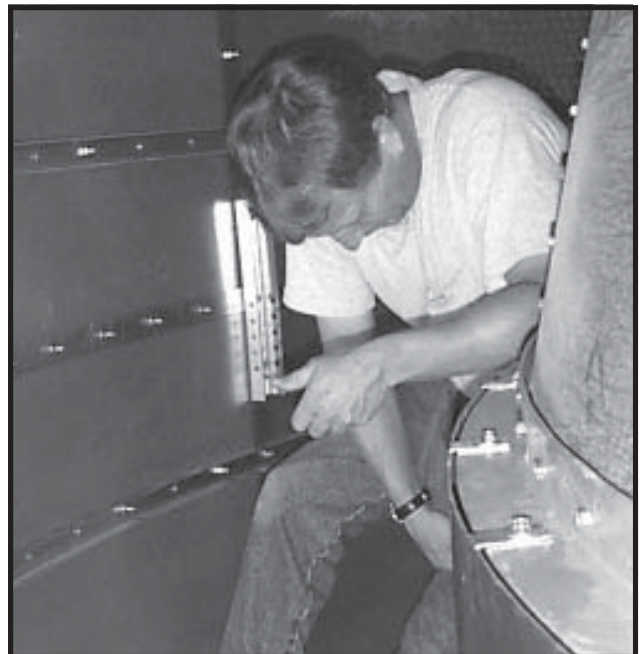

Photo 13-44

13.5. Divider Hopper.

Divider Hopper is formed by joining Inner Divider Hopper sections and Outer Divider Hopper sections in a “V” shape.

Divider Hopper encircles Fan cluster.

Divider Hopper divides Heat Section from Cool Section.

Divider Hopper fits between Fan Skirting and inner wall of dryer.

For Divider Hopper placement in your dryer model, see Illustrations 13-4 to 13-7.

✓ Keep “V” of Divider Hopper level.

13.5.1. Snug bolt top tabs (closely spaced) on Inner Divider Hopper sections to bottom of Blower Skirting. (Photo 13-46)

Snug bolt Inner Divider Hopper sections together.

✂ Use 5/16” x 3/4” bolts and nuts.

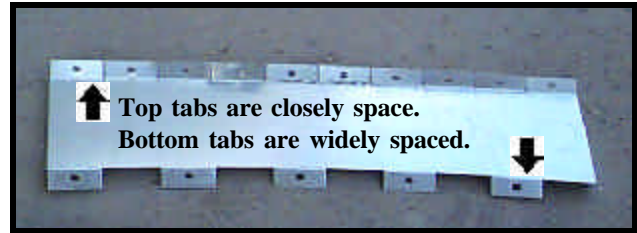

Photo 13-45 Inner Divider Hopper section.

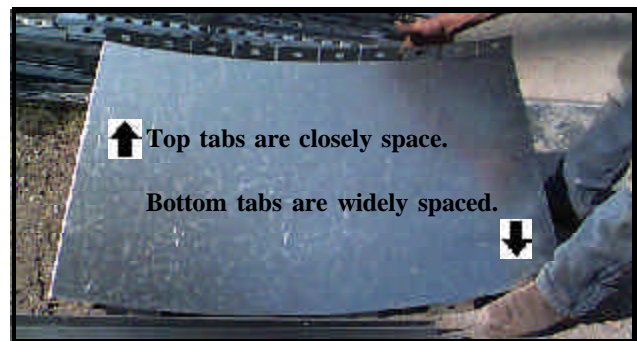



Photo 13-46 Outer Divider Hopper section.



Photo 13-47 Bolting top tabs of Inner Divider Hopper to bottom of Fan Skirting.

13.5. Divider Hopper continued

13.5.2. Align and snug bolt bottom tabs (widely spaced) on Outer Divider Hopper sections to bottom tabs on Inner Divider Hopper sections.

 Use 5/16" x 1-1/4" bolts and nuts. Space tabs with 3/8" nut in between. (Photo 13-50)

Snug bolt Outer Divider Hopper sections together.

 Use 5/16" x 3/4" bolts and nuts.

13.5.3. Drill Inside Wall Sheets to meet bolt holes in top tabs of Outer Divider Hopper. Snug bolt.

 Use 5/16" x 3/4" bolts and nuts.

 Leave Divider Hopper bolts loose, until after Reducer Walkway is installed.



Photo 13-48 Bolting Inner Divider Hopper Sections together.



Photo 13-49 Bolting Outer Divider Hopper to Inner Divider Hopper.



Photo 13-50 Close up - Using 3/8" nut (arrow) to space Outer Divider Hopper 1/4" from Inner Divider Hopper. Note: space between tabs will be 1/4" when outside nut is installed.

13.5. Divider Hopper continued



Photo 13-51 Drilling bolt holes in Inside Wall Sheets to bolt to Outer Divider Hopper.



Photo 13-52 Close up - Bolting Outer Divider Hopper to Inside Wall Sheet.



Photo 13-53 View from above Divider Hopper - Note: Wait to tighten Divider Hopper and Fan Skirting until after installing Reducer Walkway Support Beam (arrow).

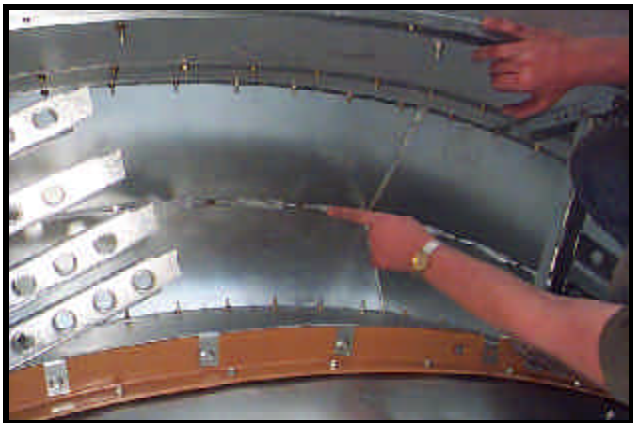

Photo 13-54 View from above Divider Hopper (in Heat Section) - completed Divider Hopper.

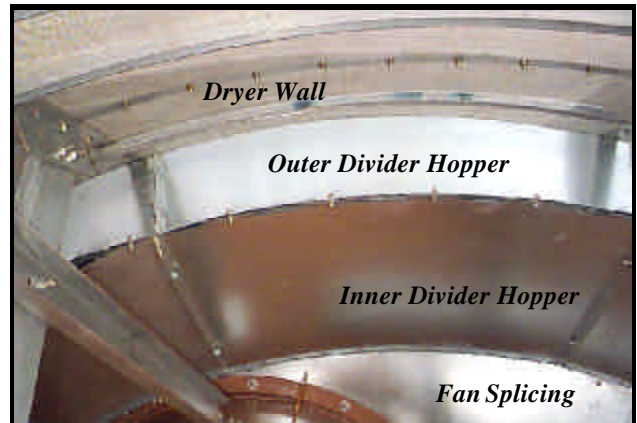

Photo 13-55 View from below Divider Hopper (in Cool Section) - completed Divider Hopper.

13.6. Reducer Walkway.

For Reducer Walkway placement in your dryer model, see Illustrations 13-4 to 13-7.

Reducer Walkway encircles Fans.

✓ Keep Reducer Walkway level.

13.6.1. Bolt Reducer Walkway Support Clips to Inside Wall Sheets with existing bolts (unless Reducer Walkway Support Clips were installed when Fan X-Bracing was installed.) (Photo 13-33)

13.6.2. Install all Reducer Walkway Support Beams as follows.

Snug bolt tab end of Reducer Walkway Support Beam over bottom ring of Reducer.

✎ Use common bolt (5/16" x 3/4") used to bolt Fan Skirting.

Snug bolt opposite end of Reducer Walkway Support Beam to Reducer Walkway Support Clip.

✓ Check with level to determine which bolt hole on Reducer Walkway Support Clips will keep Reducer Walkway level.

✎ Use 5/16" x 3/4" bolts and nuts.

13.6.4. Adjust and tighten bolts on Divider Hopper and Reducer Walkway Support Beams.

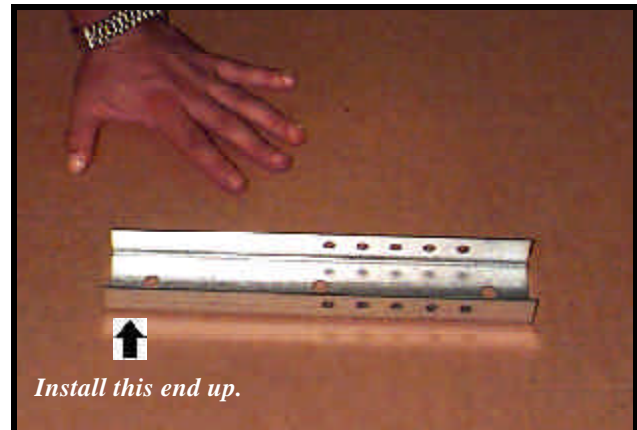

Photo 13-56 Reducer Walkway Support Clip.

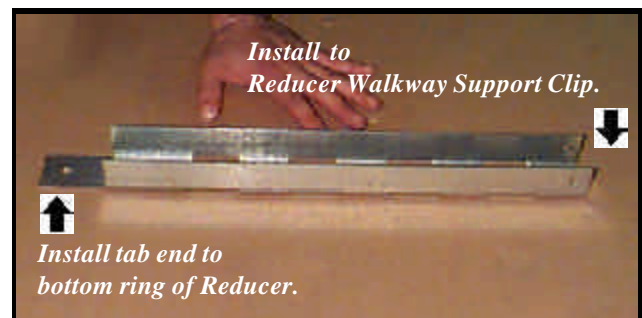

Photo 13-57 Reducer Walkway Support Beam.



Photo 13-58 Example - Reducer Walkway Slats.

13.6.5. Insert tabs on Reducer Walkway Slats into slots on Reducer Walkway Support Beams until Slats form Reducer Walkway that completely encircles Blowers.

Install shortest Slats next to Fan Skirting. Install increasing longer Slats as required.

13.6.4. Adjust and tighten bolts on Reducer Walkway and Fan Skirting.

13.6. Reducer Walkway continued



Photo 13-59 Close up - Inserting tab of Reducer Walkway Slat into slot on Reducer Walkway Support Beam.

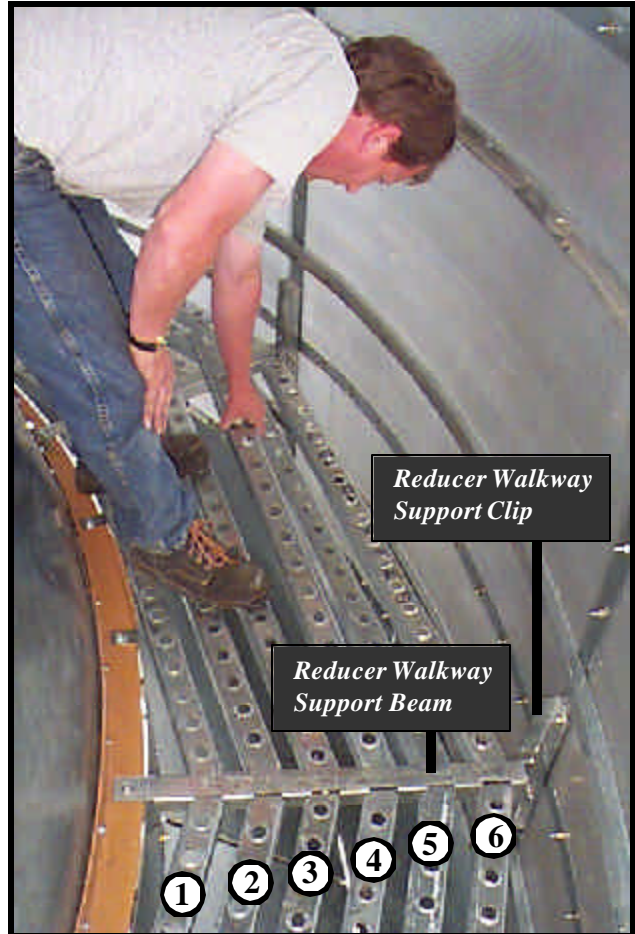

Photo 13-60



Photo 13-61 Aerial view - Completed installation of Burner, Reducer, Fans, & Divider Hopper under Reducer Walkway.

- Reducer Walkway Slat (1)
- Reducer Walkway Slat (2)
- Reducer Walkway Slat (3)
- Reducer Walkway Slat (4)
- Reducer Walkway Slat (5)
- Reducer Walkway Slat (6)

**Important Safety Precautions:**

Dryer has sharp edges. These sharp edges may cause serious injury. Use appropriate Personal Protective Equipment. Use proper lifting techniques.



See Chapter 1 “Orientation” for dryer dimensions, components, wall sheet guidelines, etc. See Appendices for “Tools and Equipment”, “Hardware”, etc.

14. Fan Motors



(Install Fan Motors before installing Dryer Windows.)

Fan Motor Mounts Fan Motors Sheaves & Fan Belts

14.1. Fan Motor Mounts

Install Fan Motor Mounts to each Fan as follows.



Use hardware in Standard Hardware Kit. (Photo 14-2)

14.1.2. If necessary, lift dryer for clearance to install Fan Motor Mounts.

14.1.3. Install Fan Motor Mount to bottom of Fan.



Photo 14-1 Fan Motor Mount (arrow).

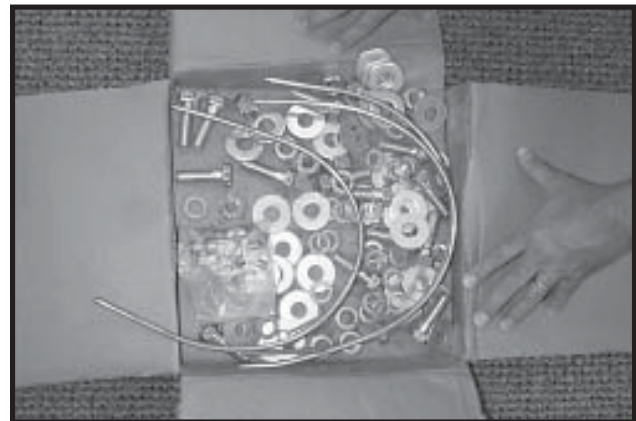

Photo 14-2 Standard Hardware Kit. (1 per fan)

14.1. Fan Motor Mounts continued



Photo 14-3 Moving Fan Motor Mount under Fan.



Photo 14-4 Align Fan Motor Mount and bolt to Fan.



Photo 14-5 Bolting Motor Mount to bottom ring of Fan.



Photo 14-6 Tighting bolts on Fan Motor Mount.



Photo 14-7 Fan Motor Mount installed.

14.2. Fan Motors

Install Fan Motor to each Fan Motor Mount as follows.

Lift or lower dryer as necessary to install Fan Motors.

14.2.1. Attach lifting tackle to Fan Motor.
(Photo 14-8) Lift Fan Motor onto Fan Motor Mount, with Drive Shaft up.

14.2.2. Bolt Fan Motor to Fan Motor Mount in bolt holes appropriate to motor size.

May be necessary to lift dryer to insert bolts.



Use 5/8" x 2" bolts, nuts and washers from standard hardware kit.



Photo 14-9 Moving Fan Motor to Fan Motor Mount.



Photo 14-10 Bolting Fan Motor to Fan Motor Mount.



Photo 14-8 Attach lifting tackle to Fan Motor.

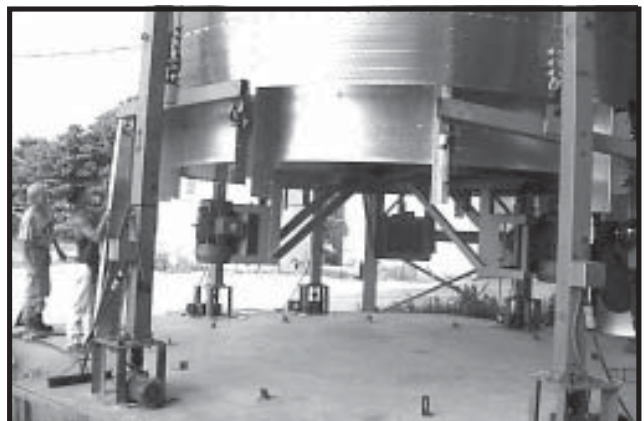

Photo 14-11 Fan Motors installed to Fan Motor Mounts.

14.3. Sheaves.

Install Sheaves to each Fan Motor as follows.

14.3.1. Lift dryer for clearance.

14.3.2. Motor Drive Shaft.

Install Motor Hub to Motor Drive Shaft. Insert Motor Hub Key. Set set screw. Slide Motor Sheave on Motor Drive Shaft and bolt.

14.3.3. Fan Drive Shaft.

Install Fan Hub to Fan Drive Shaft. Insert Fan Hub Key. Tighten set screw. Slide Fan Sheave on Fan Drive Shaft and bolt.

14.3.4. Align top of Motor Sheave level with top of Fan Sheave.



Check with level.



Note final tightening of bolts should be with torque wrench.

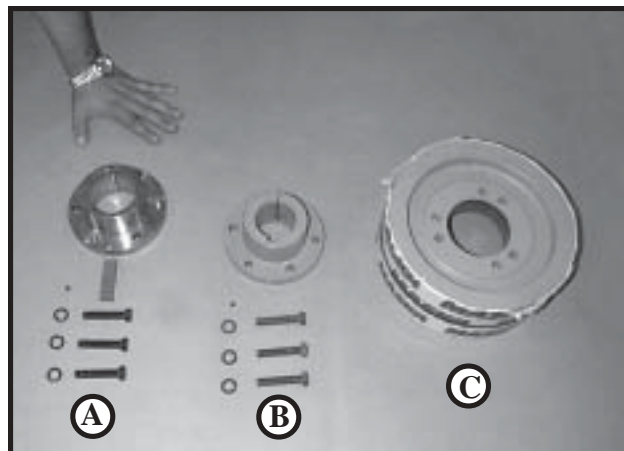

Photo 14-12

(A) Fan Hub, Fan Hub key, set screw, (3) tightening bolts, (3) lock washers

(B) Motor Hub, set screw, (3) tightening bolts, (3) lock washers (Motor Hub Key is shipped on drive shaft of Fan Motor)

(C) Motor Sheave



Photo 14-14 Sliding Motor Hub on Motor Drive Shaft.



Photo 14-13 Fan Sheave.

14.3. Sheaves continued



Photo 14-15 Tightening set screw on Motor Hub.



Photo 14-16 Sliding Motor Sheave on Motor Drive Shaft.



Photo 14-17 Inserting Motor Sheave to Motor Hub.



Photo 14-18 Sliding Fan Hub on Fan Drive Shaft.



Photo 14-19 Placing Fan Hub Key in Fan Hub.



Photo 14-20 Tightening set screw on Fan Hub.

14.3. Sheaves continued



Photo 14-21 Sliding Fan Sheave on Fan Drive Shaft.



Photo 14-23 Tightening Fan Sheave bolts.



Photo 14-22 Checking top of Motor Sheave is level with top of Fan Sheave.



*Photo 14-24 Tightening Motor Sheave bolts.
Note final tightening of bolts should be with torque wrench.*

14.4. Fan Belts



When installing Fan Belts, do not catch fingers in Fan Belts.

14.4.1. For each Fan, run Fan belts from Motor Sheave to Fan Sheave.

14.4.2 To tighten Fan Belts, tighten adjusting nuts on (2) rods on Motor Mount. Do not overtighten Fan Belts.



Check Fan Belt tension. Fan Belts will press down about one Fan Belt width.
(Photo 14-29)



*Photo 14-25
Fan Belts*



Photo 14-26 Running Fan Belts in grooves on sheaves.



Photo 14-27 (To tighten Fan Belts) tightening adjusting nuts on top rod of Motor Mount.



Photo 14-28 Tightening adjusting nuts on bottom rod of Motor Mount.



Photo 14-29 Checking Fan Belt tension. Can press down about one Fan Belt width.

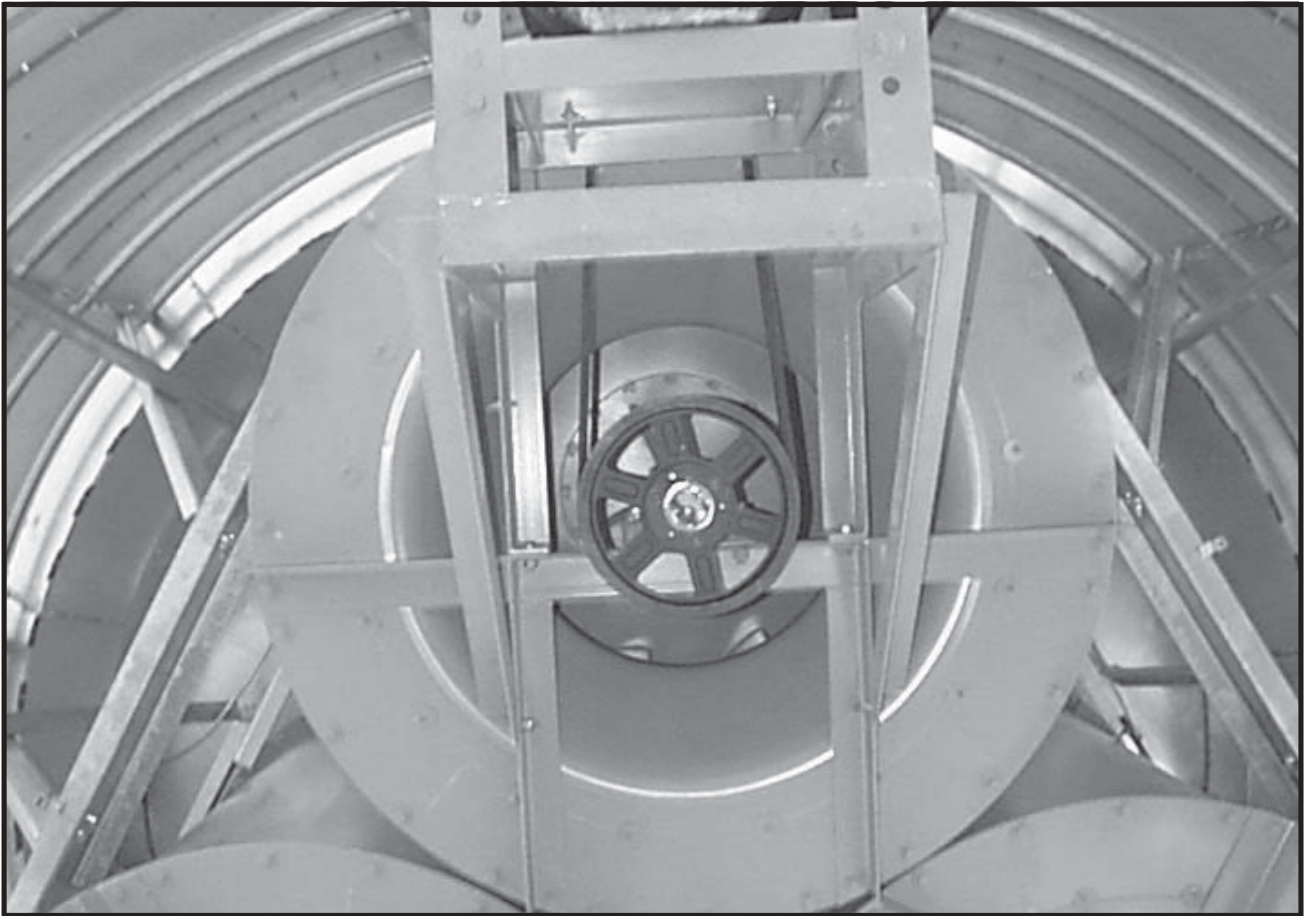

Photo 14-30 Fan Sheave and belts installed.

**Important Safety Precautions:**

Dryer has sharp edges. These sharp edges may cause serious injury. Use appropriate Personal Protective Equipment. Use proper lifting techniques.



See Chapter 1 “Orientation” for dryer dimensions, components, wall sheet guidelines, etc. See Appendices for “Tools and Equipment”, “Hardware”, etc.

15. Grease Tubes



Upper Bearing on Fan requires Grease Tube for access.



Lower Bearing on Fan requires no Grease Tube.



All required fittings are shipped attached to Grease Tube.

- 15.1. Unscrew Grease Zert from Fan.
- 15.2. Install Grease Zert to coupling on Beam Clamp end of Grease Tube.
- 15.3. Install Elbow end of Grease Tube to Fan.
- 15.4. Clamp Beam Clamp to bottom edge of Fan, or where convenient.



Photo 15-2 Grease Tube for upper bearing on Fan.

(A) elbow end
(B) beam clamp end

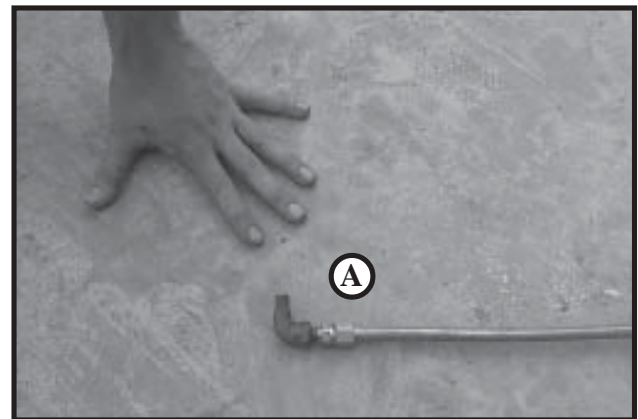

Photo 15-3 Close up - elbow end of Grease Tube (A).



Photo 15-1 Close up - Grease Zert on Fan.

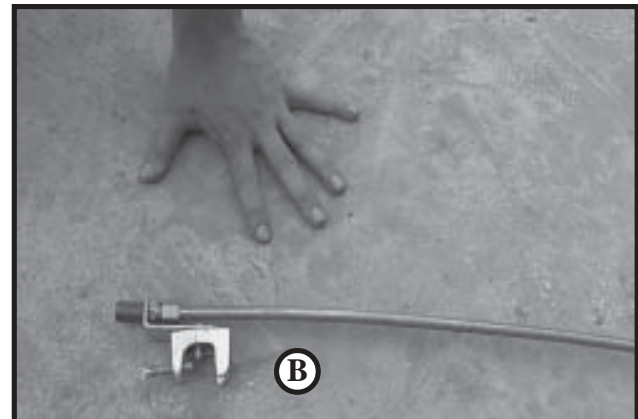

Photo 15-4 Close up - beam clamp end of Grease Tube (B).

15. Grease Tubes continued



Photo 15-5 Accessing upper Grease Zert.



Photo 15-7 Grease Zert removed from Fan.



Photo 15-8 Screwing Grease Zert into coupling on Beam Clamp end of Grease Tube.

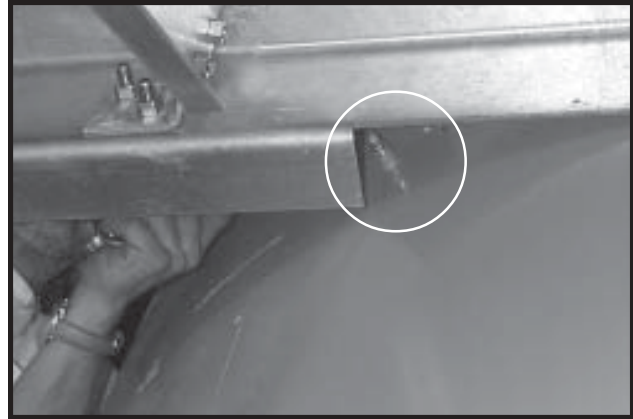

Photo 15-6 Grease Zert on Fan (circled).



Photo 15-9 Elbow and Brass Compression Union installed to Fan (circled).

15. Grease Tubes continued



Photo 15-10 Attaching Grease Tube to Brass Compression Union.



Photo 15-11 Attaching Beam Clamp to bottom edge of Fan.

**Important Safety Precautions:**

Dryer has sharp edges. These sharp edges may cause serious injury. Use appropriate Personal Protective Equipment. Use proper lifting techniques.



See Chapter 1 “Orientation” for dryer dimensions, components, wall sheet guidelines, etc.
See Appendices for “Tools and Equipment”, “Hardware”, etc.

16. Windows & Doors

- ☞ See Chapter 1, “Flat Layout” for Window and Door placement in your dryer model.
- ☞ Windows are installed in Cool Section Wall Sheets. See Chapter 1, “Flat Layout” for type of Wall Sheet to use.
- ☞ Window installation requires cutting Wall Sheets on-site.
- ✓ Check that Wall Sheets are lapped correctly, with rough side away from grain column.

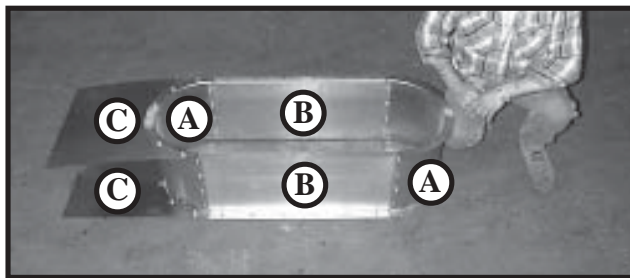

Photo 16-1 18” Window Kit
(assembled for demonstration)

- (A) Frame Top/Bottom
- (B) Frame Side
- (C) Air Deflectors
(install at bottom of frame)



24” Window Kit is not shown.
It has same parts (on larger scale)
as 18” Window Kit.

Overview

- 16.1. Pre-assembly of Window Kits**
Pre-assemble 18” Window Kit and 24” Window Kit in the same way.
- 16.2. Installation of Window Kits**
Install 18” Window Kit and 24” Window Kit to dryer in the same way.
- 16.3. Screened Windows**
Position at same level as Fan Motors.
Use 18” Window Kit and screening.
- 16.4. Louvered Windows**
Position at same level as Cool Section Door. Use 24” Window Kit and Louvered Assembly.
- 16.5. Cool Section Door**
Use 24” Window Kit, Louvered Assembly, and door parts.
- 16.6. Heat Section Door**
Use 18” Window Kit, and door parts.
- 16.7. Reducer Door**
- 16.8. Hopper Service Door**



Hardware

Assembling Window Frame
 Use 5/16" x 3/4" Slotted Truss Head bolts and 5/16" Whiz Lock nuts.

Installing Window Frame to Dryer Wall Sheets
 Drill for 5/16" x 1" whiz lock bolts and nuts.
 (stainless steel on outside, and galvanized on inside)

Window Screening
 Double nut Window Screening to Windows with existing bolts on Outside Wall Sheets.

Louvered Assembly
 5/16" x 3/4" whiz lock bolts and nuts



Photo 16-3 5/16" x 3/4" Slotted Truss Head bolt and 5/16" Whiz Lock nut.



Photo 16-4 Use Metal Shear to cut Wall Sheets and screen.



Photo 16-2 Louvered Assembly.



Photo 16-5 Bulb Seal.

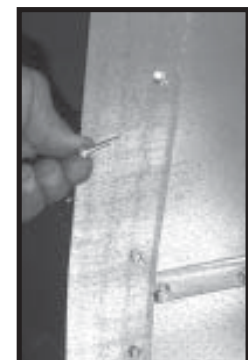

Photo 6-6 Self-tapping #10 x 1" screw.

16.1 Pre-assembly of Window Kits

Pre-assemble 18" & 24" Window Kits in the same way.



Photo 16-7 On a raised support, layout Inside Wall Sheets that will support assembled Window. Lap Wall Sheets as they should be lapped on dryer.



Photo 16-8 Align bolt holes in the two Wall Sheets.



Photo 16-9 Temporarily snug bolt corners of two Wall Sheets.

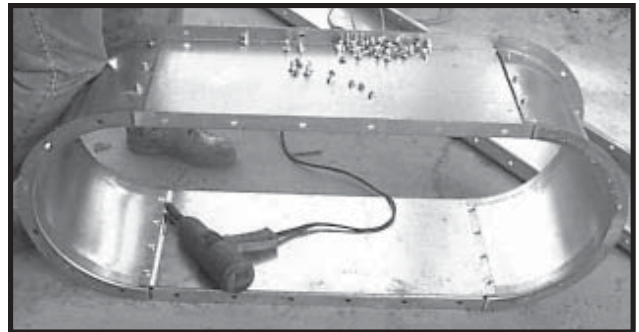

Photo 16-10 Assemble Window Frame, using 5/16" x 3/4" slotted truss head bolts & 5/16 whiz lock nuts.

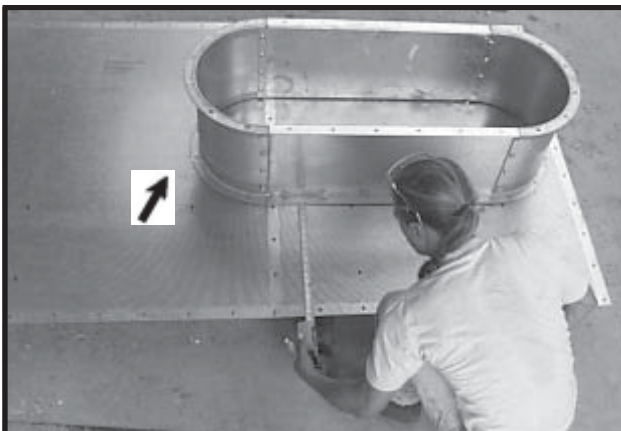

Photo 16-11 Check Chapter 1, "Assembly Layout" for placement of Window Frame on Wall Sheets. Leave room below Window Frame (arrow) for Air Deflector.



Photo 16-12 Mark around inside perimeter of Window Frame.

16.1 Pre-assembly of Window Kits continued

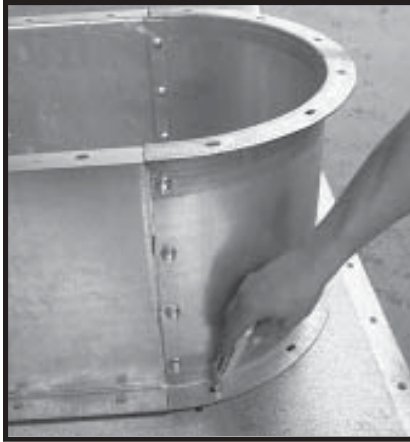

Photo 16-13 Close up - Mark Window Frame bolt holes.

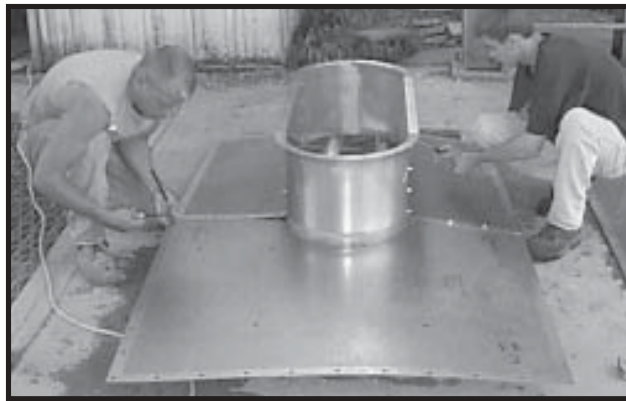

Photo 16-15 After cutting Window Outline, realign Window Frame to Wall Sheets and drill out bolt holes.

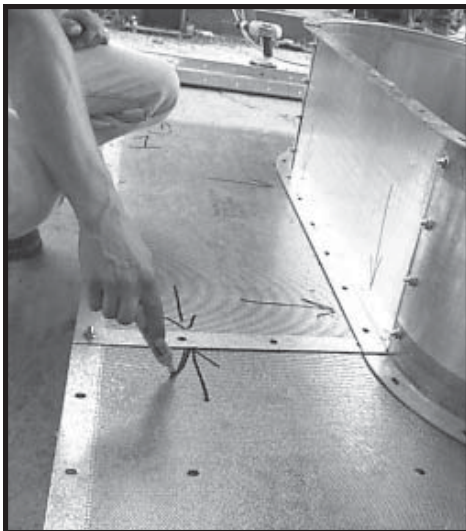

Photo 16-17 Match marks on each sheet. Draw arrow to indicate "up" direction for installation.

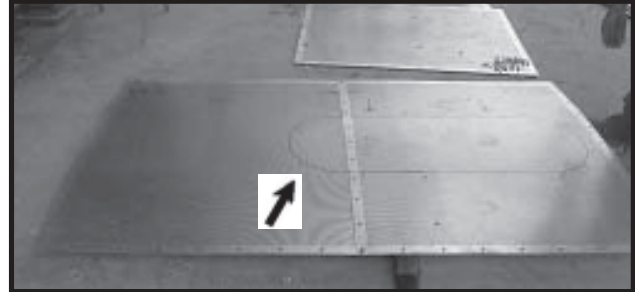



Photo 16-14 Line marked (by arrow) is inside perimeter of Window Frame. Cut on outside of line because Wall Sheets will lie inside Window Frames.

 Can save Wall Sheet cutout to use as a pattern on next dryer installed.

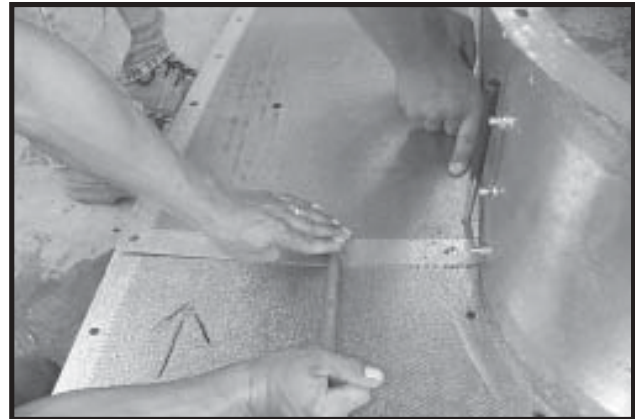

Photo 16-16 Close up - Aligning Wall Sheets to Window Frame so bolt holes can be drilled. Note Wall Sheets are installed on top of Window Frame flange.



Photo 16-18 Bolt Window Frame to Wall Sheets.

Drill bolt holes for Air Deflector at bottom of Window Frame, drilling 1" x 1" from corners.

16.2. Installation of Window Kits (18" & 24")

Install 18" & 24" Window Kits in the same way.

Read Steps 16.3 to 16.6 for additional installation information.



Photo 16-19 Hang Pre-assembled Wall Sheets, Window Frame, and Air Deflector.



Photo 16-20 Bolt Wall Sheets in place. Install Rolled Plenum Channels. Check that Window Frame is level and square to dryer.

16.2. Installation of Window Kits continued

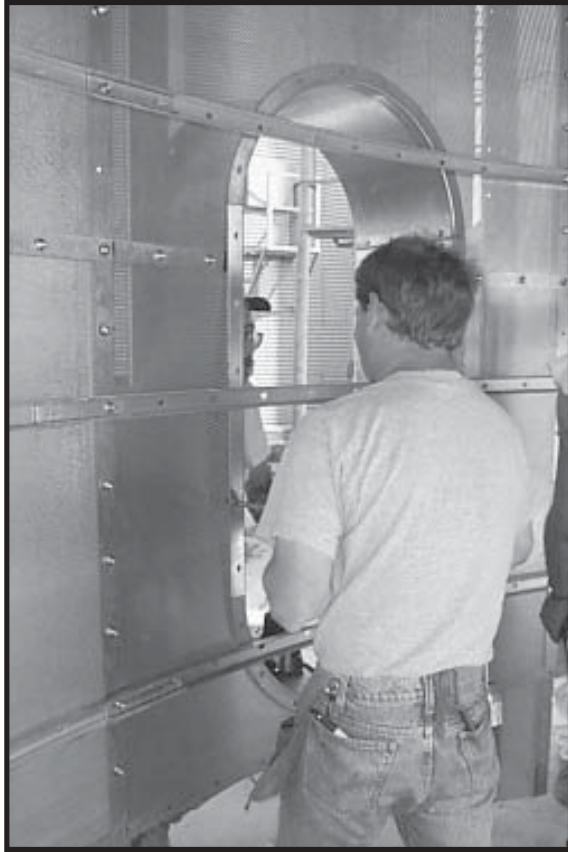

Photo 16-21 Install Rolled Plenum Channels.



Photo 16-22 Drill and bolt Rolled Plenum Channels, then cut away from Window Frames.



Photo 16-23 Mark Outside Wall Sheets so they will fit inside Window Frame.

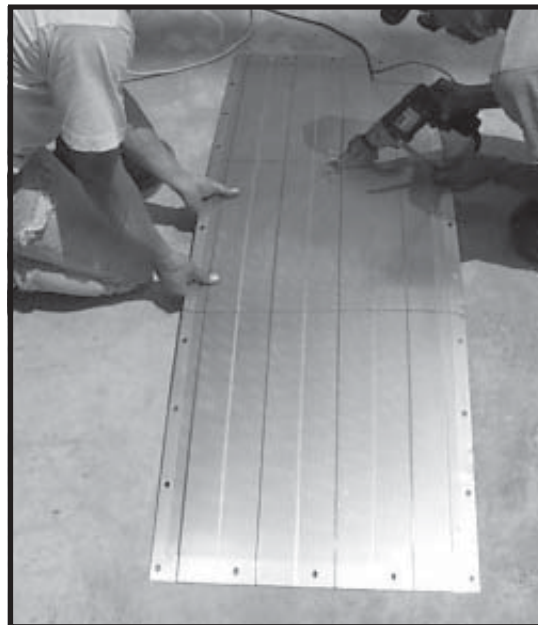

Photo 16-24 Cut Outside Wall Sheets on inside of marked line so they will fit inside Window Frame. Drill bolt holes and bolt cut Rolled Plenum Channels to Window Frame.

16.2. Installation of Window Kits continued



Photo 16-25 Fit Outside Wall Sheets to Window Frame.



Photo 16-26 Bolt Outside Wall Sheets inside Window Frame.



Photo 16-27 Bolt Window Frame to Outside Walls. Note Air Deflector (arrow) is below Window Frame and inside Outside Wall Sheets.

16.3. Screened Windows

See Chapter 1, “Flat Layout”, for Window placement in your dryer model.

 Screened Windows provide free air and cool Fan Motors.

 Be sure each Fan Motor is centered in a Screened Window. (Photo 16-x)

 Check that 18” Screened Windows are level and square to dryer.

16.3.1. Pre-assemble 18” Window Kit as in Step 16.1. This is the Window Frame.

16.3.2. Install Window Frame to dryer as in Step 16.2.

16.3.3. Trim window screening to size of Window Frame.

 Double nut screening to Window with existing bolts on Outside Wall Sheets.

Tighten bolts securely.

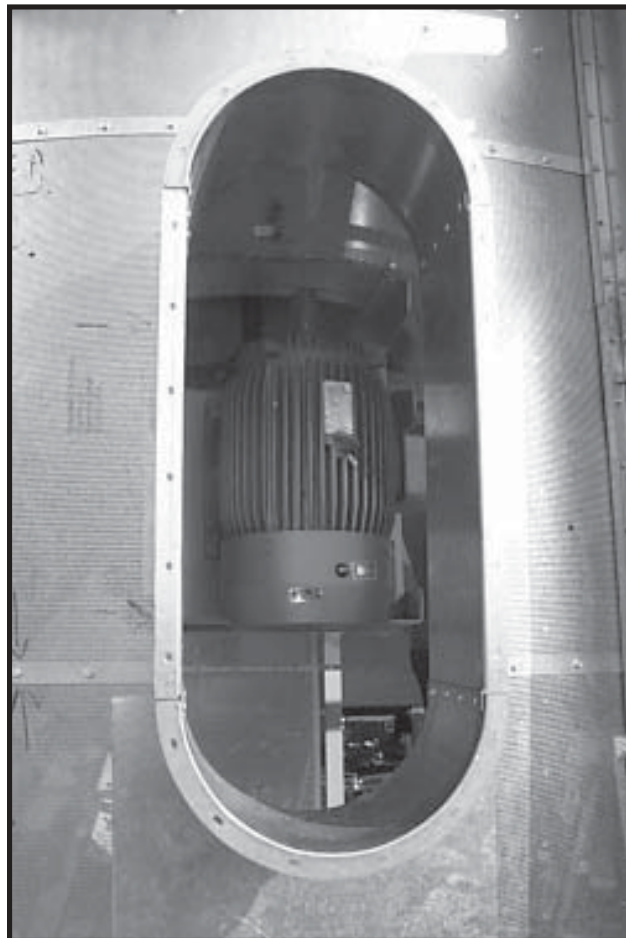

*Photo 16-28 Window is centered on Fan Motor.
Note Window Screen and Outside Wall Sheets are not yet installed.*



Photo 16-29 Inside View - Window is centered on Fan.

16.3. Screened Windows continued



Photo 16-30 18" Window is installed. (Screening is not yet installed.)

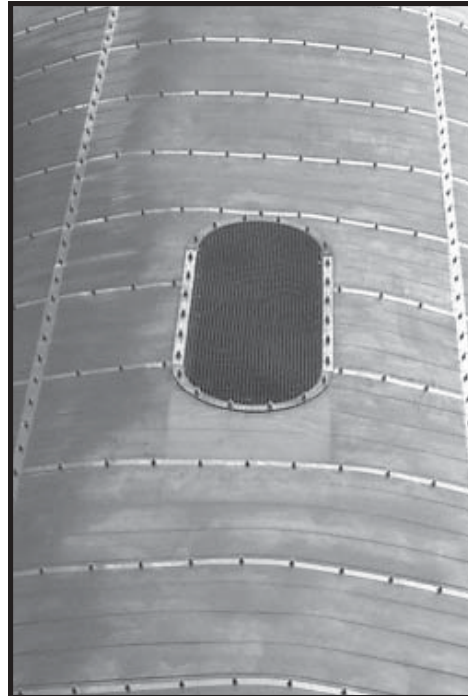

Photo 16-31 Screening is installed over Window.



Photo 16-32 Close up - 18" Window installed. (Screening is not yet installed.)

16.4. Louvered Windows

See Chapter 1, “Flat Layout”, for Window placement in your dryer model.

- ✓ Check that 24” Louvered Windows are level and square to dryer.

16.4.1. Pre-assemble 24” Window Kit as in Step 16.1. This is the Window Frame.

16.4.2. Install Window Frame to dryer as in Step 16.2.

16.4.3. Install Louvered Assembly to window frame as follows.

- 🔩 Use 5/16” x 3/4” whiz lock bolts and nuts.

With common bolts, install Latch/Hinge Bracket to both LH and RH sides of Window Frame, bolting through Outside Wall Sheets. (Photo 16-33)

Bolt Louvered Assembly to tabs on Latch/Hinge Bracket on one side.



Photo 16-33 Use common bolts on Latch/Hinge Bracket, Window Frame, and Outside Wall Sheets (arrow). Insert bolts toward inside of dryer.

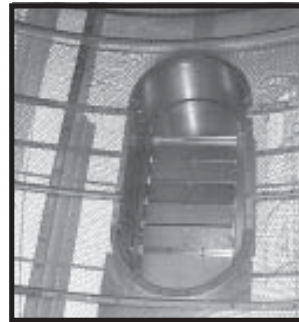

Photo 16-34 Installed 24” Louvered Window, with louvers closed.



Photo 16-35 Installed 24” Louvered Window, with louvers open.



Photo 16-36 Outsided view - installed 24” Louvered Window, with louvers open.

16.5. Cool Section Door

See Chapter 1, "Flat Layout", for Cool Section Door placement in your dryer model.

- ✓ Cool Section Door should allow comfortable step-in access to Cool Section.
- ✓ Check that Cool Section Door is level and square to dryer.
- ☞ Caulking and Bulb Strip are not required.

16.5.1. Pre-assemble 24" Window Kit as in Step 16.1. This is the Cool Section Door Frame.

16.5.2. Install Cool Section Door Frame to dryer as in Step 16.2.

16.5.3. Install Louvered Assembly to Cool Section Door Frame as follows.

- 🔧 Use 5/16" x 3/4" bolts and nuts.

With common bolts, install Latch/Hinge Bracket to both LH and RH sides of Window Frame, bolting through Outside Wall Sheets. (Photo 16-33)

Bolt Louvered Assembly to tabs on Latch/Hinge Bracket on one side. Pin closed.

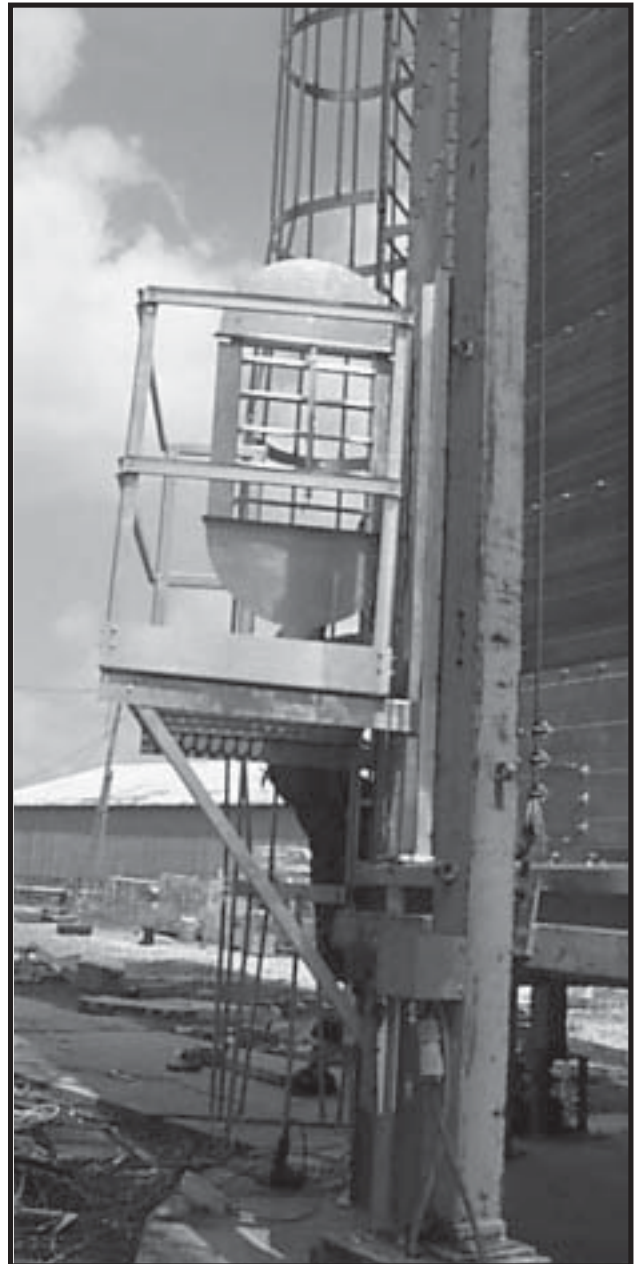

Photo 14-37 Cool Section Door is installed.

16.6. Heat Section Door

See Chapter 1, “Flat Layout”, for Heat Section Door placement in your dryer model.

Locate Heat Section Door to right of Outside Ladder. Center Heat Section Door between two Vertical Channels.

- ✓ Heat Section Door placement should give comfortable step-in access to Reducer Walkway.
- ✓ Check that Heat Section Door is level and square to dryer.

16.6.1. Pre-assemble 24” Window Kit as in Step 16.1. This is the Door Frame.

16.6.2. Install Door Frame to dryer as in Step 16.2.

16.6.3. Install Heat Section Door as follows.

☞ Flange on Heat Section Door faces to outside of dryer.

🔧 Use 5/16 x 3/4” whiz lock bolts and nuts, except where noted.

Bolt Hinge-Door Side to Heat Section Door.

Bolt Hinge-Frame Side to Hinge-Door Side.

Bolt Hinge-Frame Side to Door Frame.

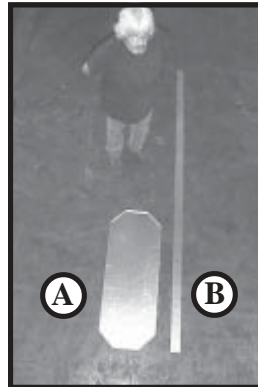

Photo 16-38
 (A) Heat Section Door
 (flange faces to outside.)
 (B) 3” wide Heat Section Door Sleeve

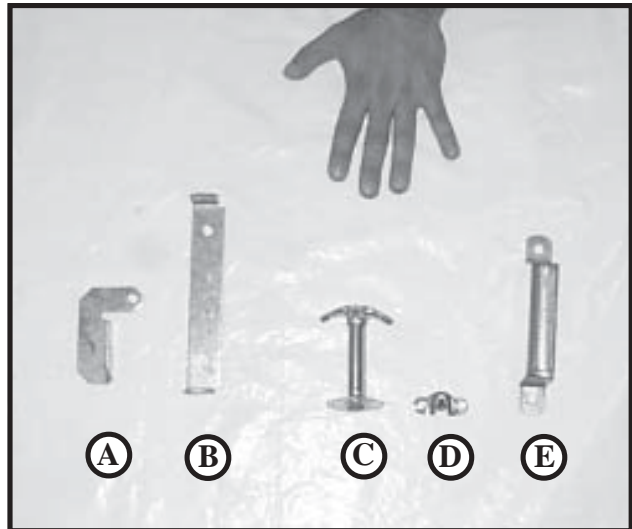
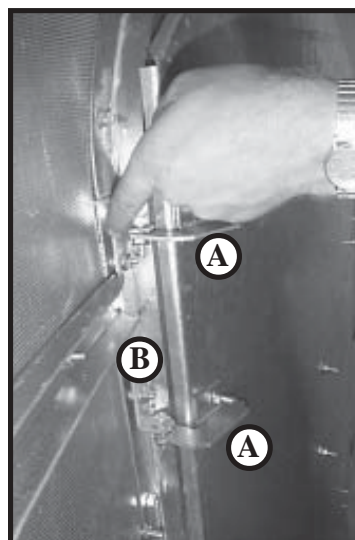

Photo 16-39



Photos 16-39 & 16-40
 (A) Hinge-Door Side
 (B) Hinge-Frame Side
 (C) Door Latch
 (D) Hooking Bracket
 (E) Door Handle

Photo 16-40

16.6. Heat Section Door continued

16.6.4. Wrap 3" wide Heat Section Door Sleeve around inside of Door Frame. Tap hammer it around inside of Door Frame to fit snugly.



Open and shut Heat Section Door to check fit of Heat Section Door Sleeve to seal door. Adjust as required.



Secure Heat Section Door Sleeve with self tapping # 10 x 1" screws.

16.6.5. Apply silicone injection caulking to seal any gaps between Heat Section Door Sleeve and Door Frame.

16.6.6. Press Bulb Seal along inside edge of Heat Section Door Sleeve.

16.6.7. Bolt Door Handle to pre-drilled bolt holes on outside of Heat Section Door.



Use 5/16" x 3/4" whiz lock bolts and nuts.

16.6.8. Install Door Latch and Hooking Bracket to outside of Heat Section Door as follows.



Use #10 x 1" self-tapping screws.



Photo 16-41 Installing 3" wide Heat Section Door Sleeve.



Photo 16-42 Wrapping Heat Section Door Sleeve around inside of Door Frame.

16.6. Heat Section Door continued

16.6.8. continued

Screw (2) Door Latches in pre-drilled holes on outside of Heat Section Door.

Screw (2) Hooking Brackets to Door Frame. Position to keep Heat Section Door tightly shut.

- ✓ Check fit of Heat Section Door in Door Frame, and adjust as required.

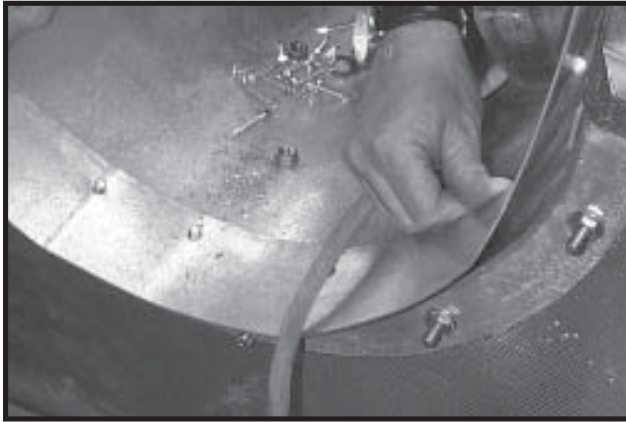

Photo 16-43 Close up -
Installing Heat Section Door Sleeve.



Photo 16-44 Tap hammering Heat Section Door Sleeve
around inside of Door Frame.

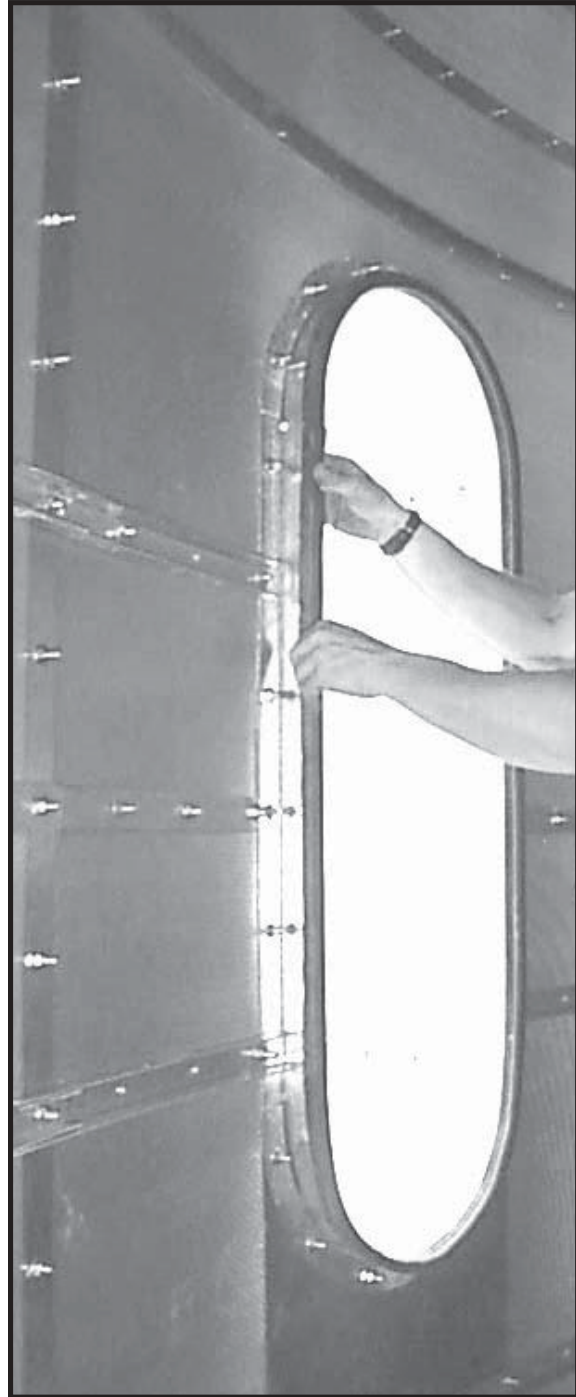

Photo 16-45 Pressing Bulb Seal around inside edge
of Heat Section Door Sleeve.

16.7. Reducer Door

Install Reducer Door to pre-cut opening in Reducer.



Use 5/16 x 3/4" whiz lock bolts and nuts.



Caulking and Bulb Seal are not required.

- 16.7.1.** Snug bolt Reducer Door Frame Top, Reducer Door Frame Bottom, and (2) Reducer Door Frame Sides to inside of pre-cut opening on Reducer. Fit Reducer Door Frame together as tightly as possible.



Check that Reducer Door Frame is level and square. Tighten bolts.



Do not tighten bolts on hinge-side of Reducer Door Frame, where Reducer Door Assembly will be installed.

- 16.7.2.** Bolt Door Latch in pre-drilled bolt holes inside Reducer.

- 16.7.3.** Install Reducer Door Assembly as follows.

Install hinge-side of Reducer Door Assembly to hinge-side of Reducer Door Frame.



Open and shut Reducer Door Assembly to check fit in Door Frame. If necessary, adjust Reducer Door Assembly.

- 16.7.4.** Adjust bolt on Door Latch so Reducer Door latches securely.

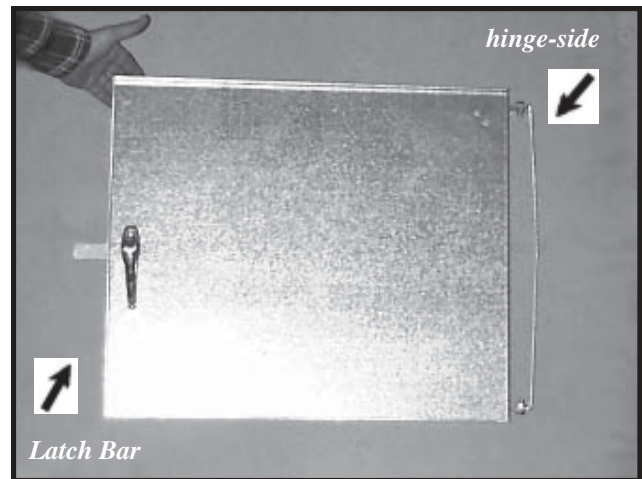

Photo 16-46 Reducer Door Assembly, with Latch Bar.
Note hinge-side.

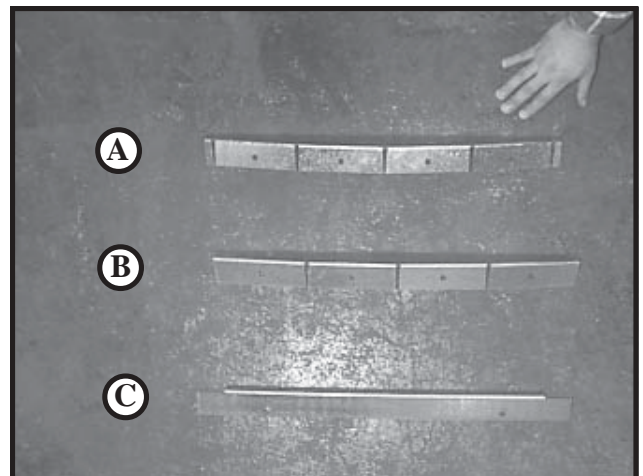

Photo 16-47
(A) Reducer Door Frame - Top
(note tabs at ends)
(B) Reducer Door Frame - Bottom
(C) Reducer Door Frame - Side

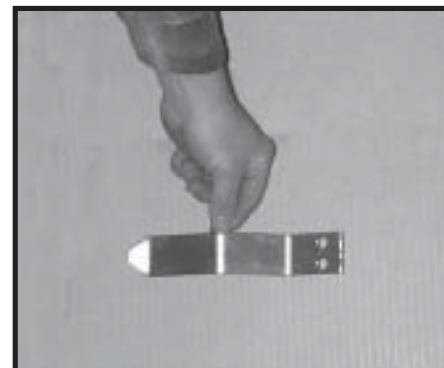

Photo 16-48 Door Latch.

16.7. Reducer Door continued

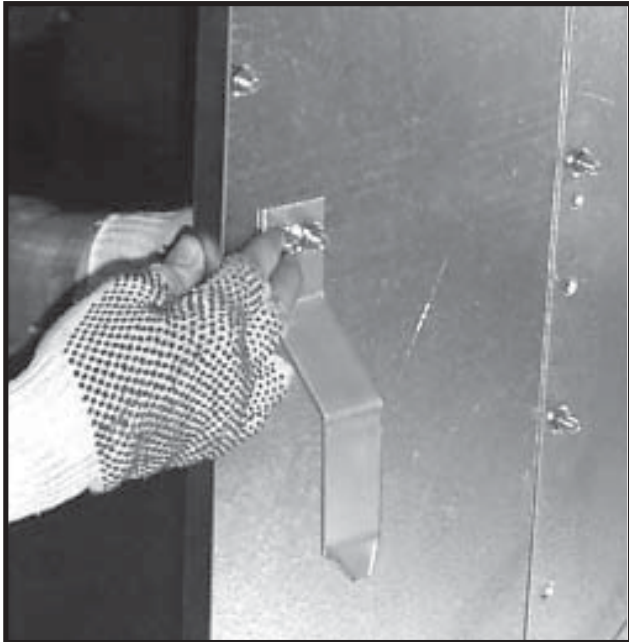

Photo 16-49 Bolting Door Latch in pre-drilled bolt holes inside Reducer.

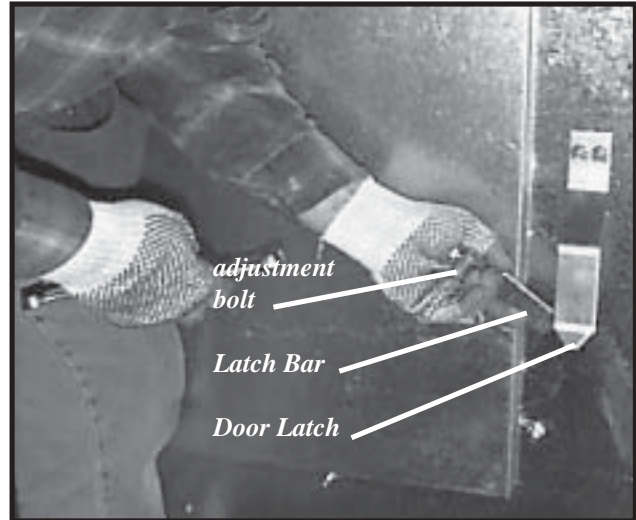

Photo 16-51 Checking latch on Reducer Door.



Photo 16-50 Adjusting bolt on Latch Bar.

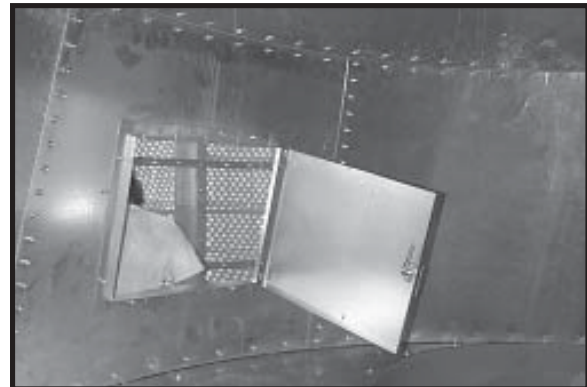

Photo 16-52 Reducer Door is installed.
Note hinges are on RH side in this example.



Photo 16-53 Reducer Door is installed.
Note hinges are on LH side in this example.

16.7. Reducer Door continued



Photo 16-54 Front of installed Reducer Door.

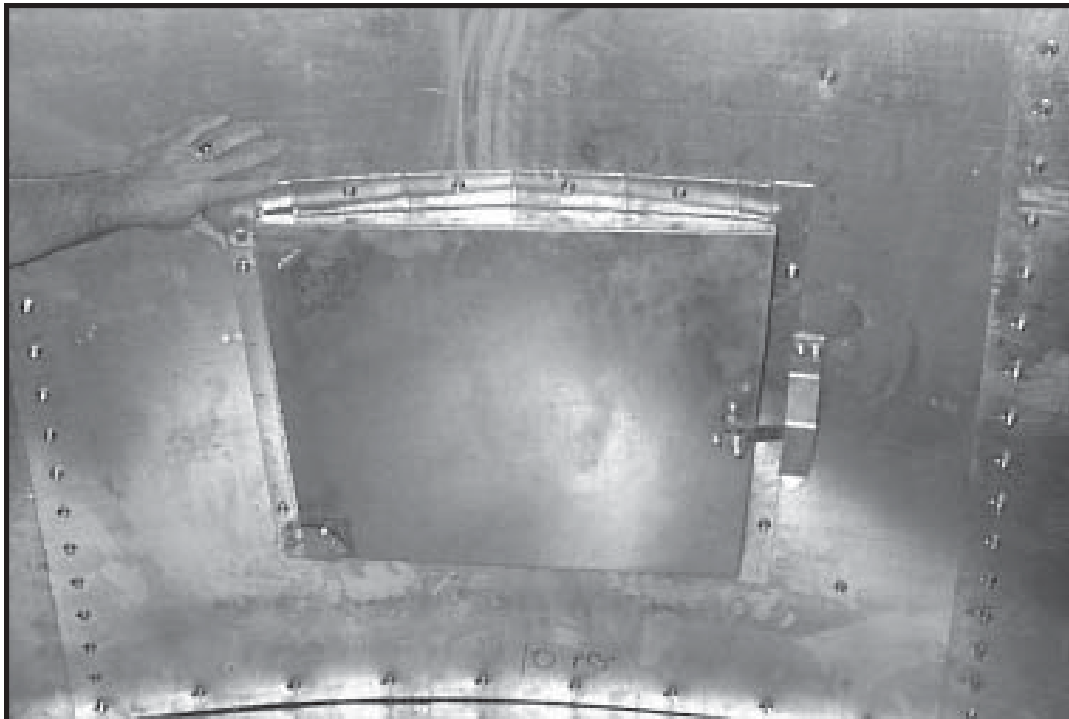



Photo 16-55 View inside Reducer - Reducer Door is installed and latched.

16.8. Hopper Service Door

After Cool Section floor is installed, install Hopper Service Door to opening in Cool Section floor.

 Hopper Service Door gives access to Metering Drum in Hopper.

16.8.1. Install (4) Door Handles in pre-drilled bolt holes in Hopper Service Door Weldment.

 Use 5/16 x 3/4" whiz lock bolts and nuts.

16.8.2. Pre-assemble (4) De Sta Co Clamps. (Photo 16-56.)

16.8.3. Press Bulb Seal around rim of Hopper Service Door Weldment.

16.8.4. Position (4) De Sta Co Clamps around opening at even intervals, to keep Hopper Service Door tightly shut.

 Install each De Sta Co Clamp with (4) #10 x 1" self-tapping screws.

Clamp Hopper Service Door in opening in Cool Section floor.

 Hopper Service Door must be in place when dryer is operating.



Photo16-56 Hopper Service Door Weldment.



Photo 16-57 Door Handle.

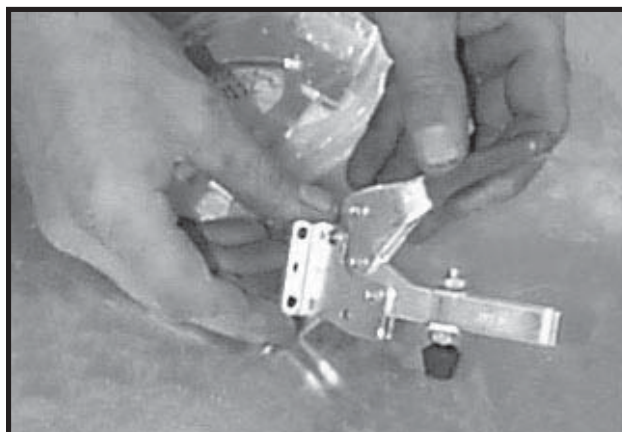

Photo 16-58 Assembled De Sta Co Clamp.

16.7. Hopper Service Door continued

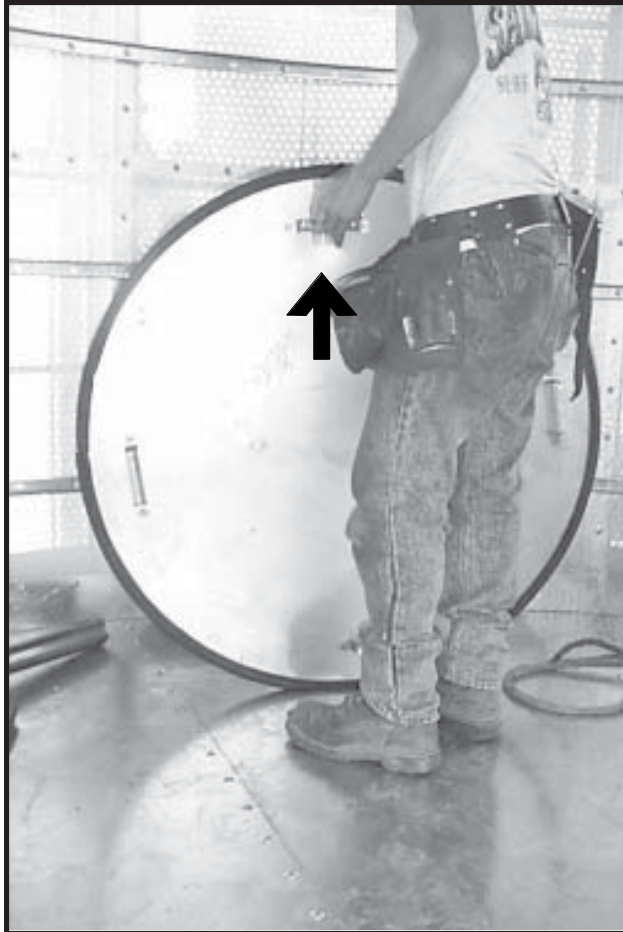

Photo 16-59 (4) Hopper Service Door Handles (arrows) installed to Hopper Service Door.

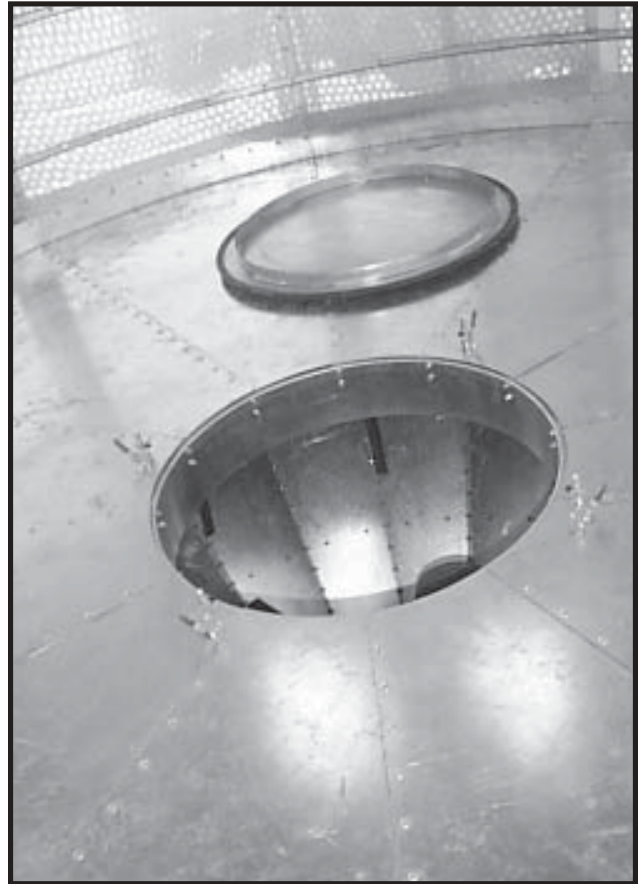

Photo 16-61 De Sta Co Clamps are installed in Cool Section Floor. Note Hopper Service Door is lifted off for access to Hopper.

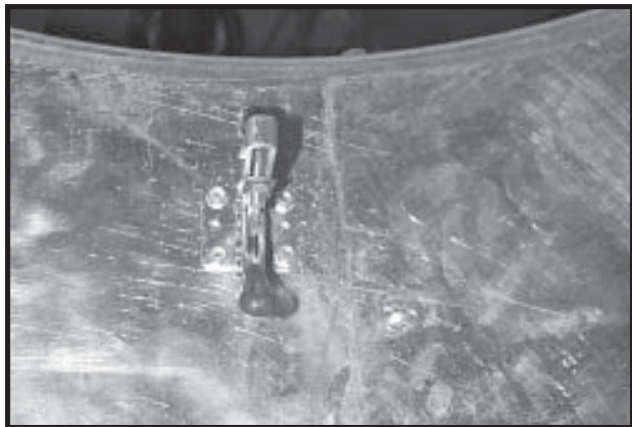

Photo 16-60 Close up - De Sta Co Clamp installed to Cool Section Floor.

Tower Base 17

Illustration 17-1
Compression Angle Weldments
Example - All Models

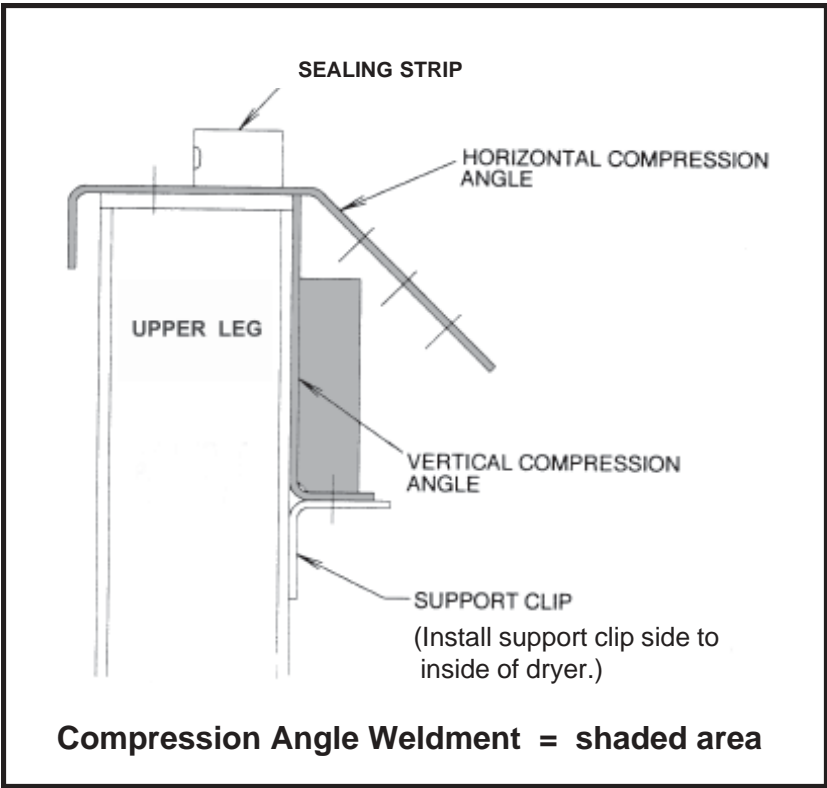
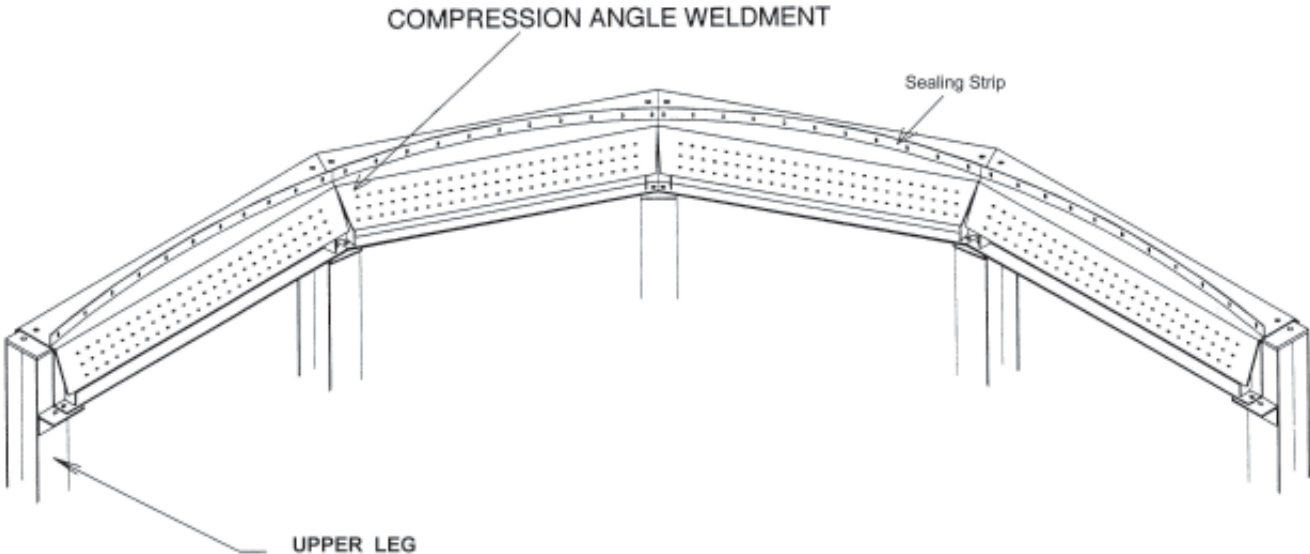
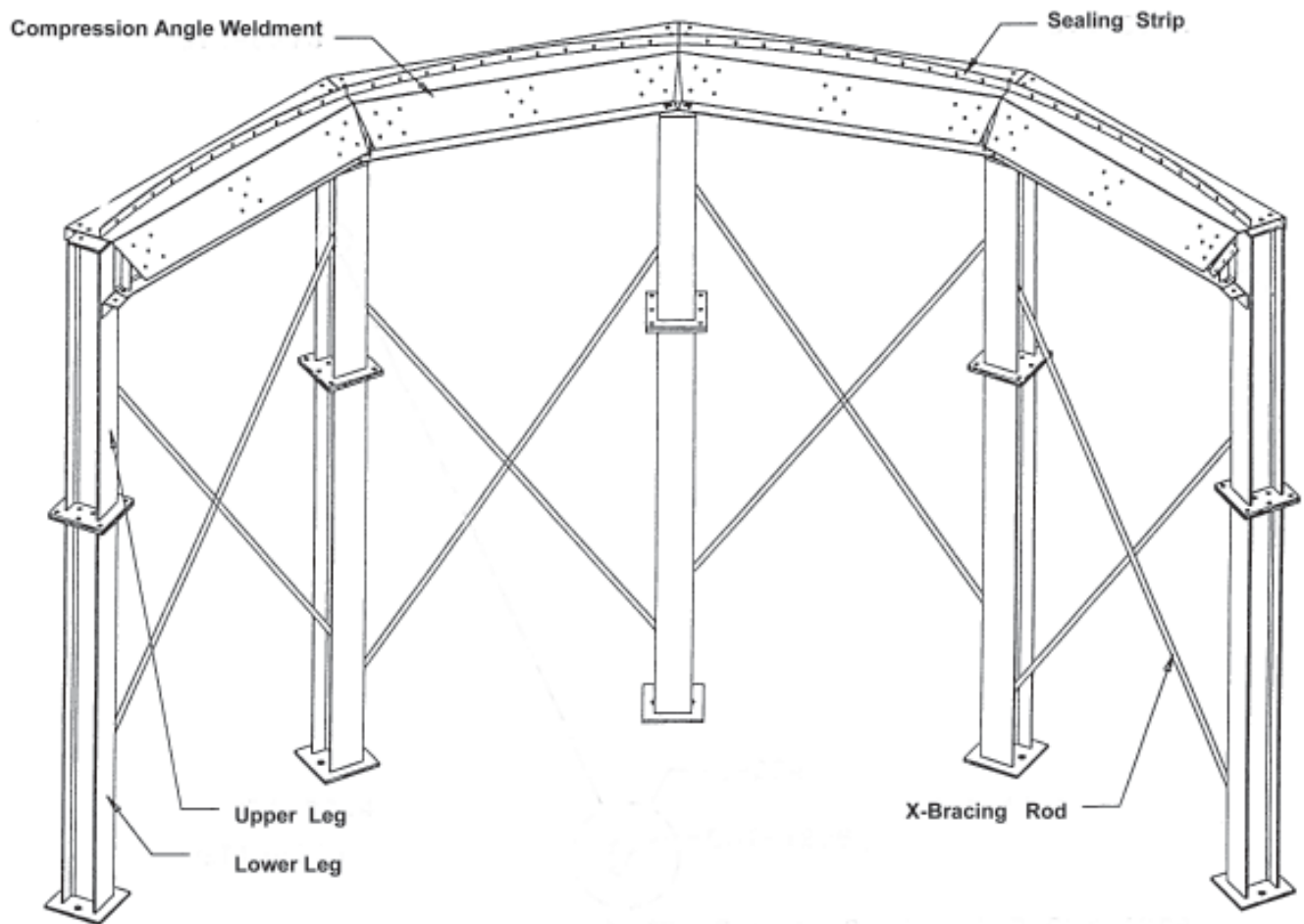

Illustration 17-2

Dryer Legs

Example - All Models



**Important Safety Precautions:**

Dryer has sharp edges. These sharp edges may cause serious injury. Use appropriate Personal Protective Equipment. Use proper lifting techniques.



See Chapter 1 “Orientation” for dryer dimensions, components, wall sheet guidelines, etc.
See Appendices for “Tools and Equipment”, “Hardware”, etc.

17. Tower Base

**Vertical Base Channels, Solid Wall Sheets, Sealing Strip,
Base Stiffener Weldments, Compression Angle Weldments,
Cool Section Floor Beam Brackets, Legs, & X-Bracing Rods**

Illustration 17-3

X-Bracing Rod Placement

Example - All Models

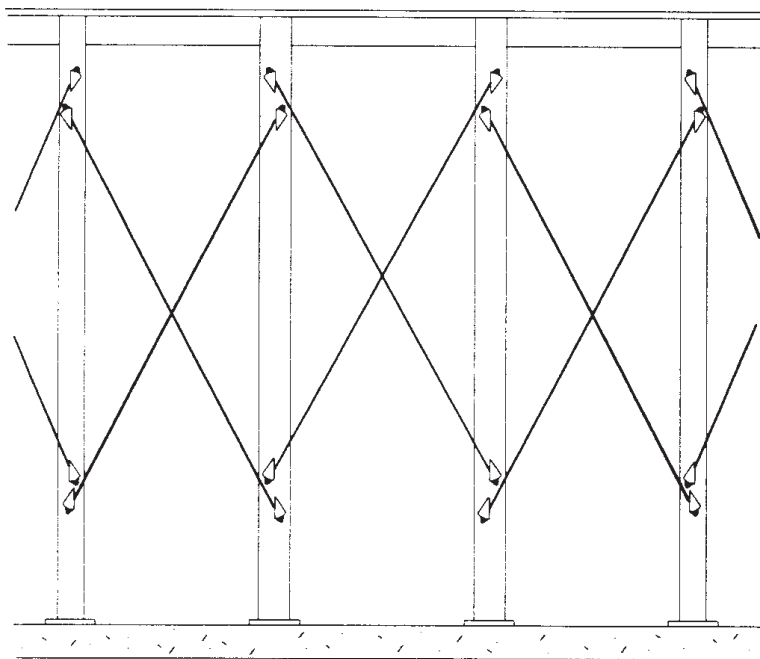

17.1. Vertical Base Channels.

Install RH Vertical Base Channels and LH Vertical Base Channels to bottom of Vertical Channel columns.

Bottom of Vertical Base Channel is angled. Attach short side of Vertical Base Channel to Jig Clip with Jig Clip Extender. (Photo 17-2)



Photo 17-1

(A) RH Vertical Base Channel

(B) LH Vertical Base Channel

17.2. Outside Solid Wall Sheets.

Last ring of Outside Wall Sheets and Inside Wall Sheets on Dryer are solid. See Chapter 1, “Assembly Layout” for placement.

Install Outside Solid Wall Sheets at base of Dryer.



After Compression Angle Weldment is installed in later step, install Inside Solid Wall Sheets at base of Dryer.

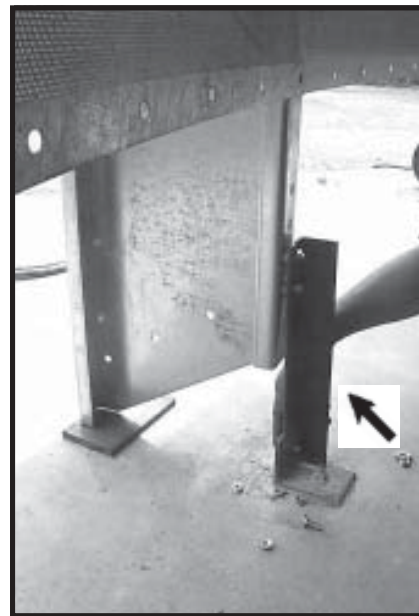

Photo 17-2 Use Jig Clips Extenders (Arrow) to attach Vertical Base Channel to Jig Clip.

17.3. Sealing Strip.

Bolt Sealing Strip (Photos 17-3 & 17-4) to bottom of Outside Solid Wall Sheets.



Use 5/16” x 3/4” whiz lock bolts and nuts.

17.4. Base Stiffener Weldment.

Bolt Base Stiffener Weldment to each Vertical Base Channel (with common bolts through Outside Wall Solid Sheets).



(Photos 17-5 to 17-7)

Use 3/8 x 1-1/2” Grade 8 bolts and nuts.

Insert bolts toward outside of dryer.



Photo 17-3 Sealing Strip.



Photo 17-4 Sealing Strip (arrow) is installed to bottom of Outside Solid Wall Sheets.

17.4. Base Stiffener Weldment. continued



IT IS IMPORTANT TO POSITION BASE STIFFENER WELDMENT CORRECTLY.

Entire weight of dryer transfers from columns of Vertical Channels through Base Stiffener Weldments to Dryer Legs. Position Base Stiffener Weldments over Sealing Strip and flush to foundation.



Check that Base Stiffener Weldment is flush (level and even) with Vertical Base Channel.



Photo 17-5 Base Stiffener Weldments as shipped.



Photo 17-6 Positioning Base Stiffener Weldment flush over Vertical Base Channel (that is under Outside Solid Wall Sheets).



Photo 17-7 Tightening Base Stiffener Weldment to Vertical Base Channel.

Note Base Stiffener Weldment is flush to foundation.

17.5. Compression Angle Weldments.

See Illustrations 17-1 & 17-2 for placement of Compression Angle Weldments.

From outside Dryer, bolt Compression Angle Weldment to Sealing Strip.
(Photos 17-9 to 17-11)



Use 5/16" x 1" bolts, nuts, and washers.

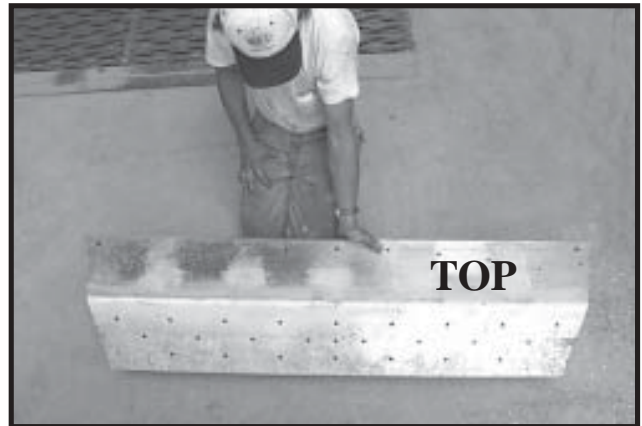

Photo 17-8 Compression Angle Weldment.

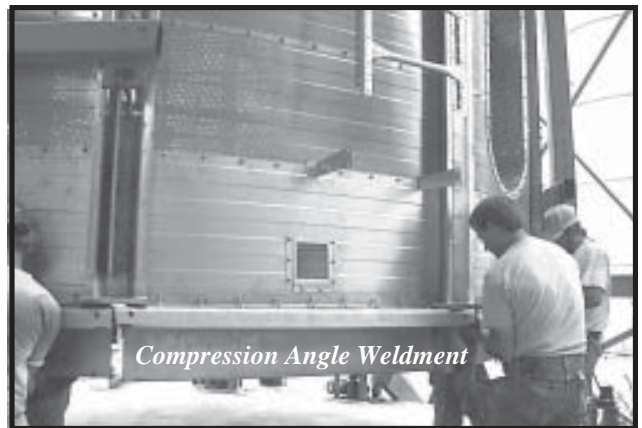

Photo 17-9 Bolting Compression Angle Weldments to bottom of Sealing Strip.

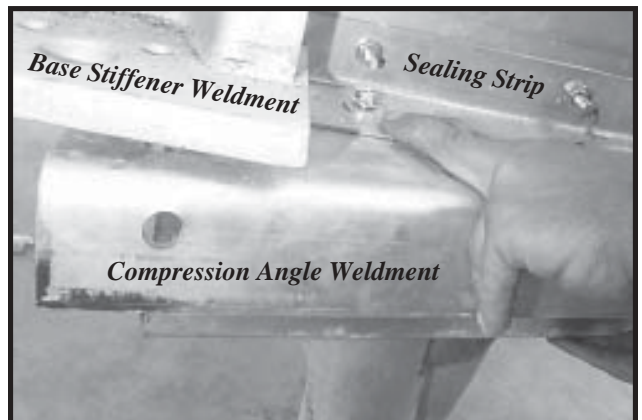

Photo 17-10 Close up - Bolting Compression Angle Weldments to Sealing Strip. Trim Sealing Strip if required.

17.5. Compression Angle Weldments. continued



Photo 17-11 Compression Angle Weldments encircle base of dryer.



*Photo 17-12 Inside View - Installing Compression Angle Weldments.
Note Inside Solid Wall Sheet will be installed after Compression Angle Weldment,
with one Rolled Plenum Channel in 4th bolt hole.*

17.6. Inside Solid Wall Sheets & Cool Section Floor Beam Brackets.

Install Inside Solid Wall Sheets at base of Dryer. Bolt Cool Section Floor Beam Brackets through Inside Solid Wall Sheets, to each Vertical Base Channel as shown in Photo 17-14. Cool Section Floor Beam Brackets face same way around perimeter of Dryer.

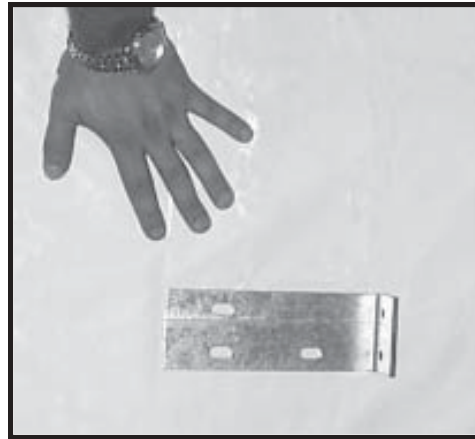

Photo 17-13 Cool Section Floor Beam Bracket.



Use 5/16" x 3/4" whiz lock bolts and nuts.



Photo 17-14 Bolt Cool Section Floor Beam Bracket (through Inside Solid Wall Sheets) to each Vertical Base Channel.



Photo 17-15

17.7. Upper Legs.

See Illustrations 17-1 & 17-2 for placement of Upper Legs. Install Upper Legs with support clip side to inside of Dryer.

Outside Dryer - Bolt Upper Leg through Compression Angle Weldment to Base Stiffener Weldment. (Photo 17-18)

 Use 5/8" x 2-3/4" Grade 8 bolts and nuts.

Inside Dryer - Bolt Support Clip on Upper Leg to Compression Angle Weldment. (Photo 17-19)

 Use 5/8 x 1-1/2" Grade 8 bolts and nuts.

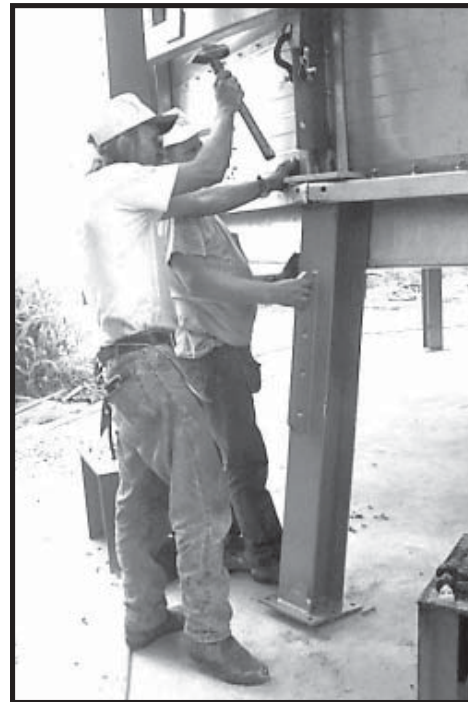

Photo 17-16 Aligning Upper Leg to Base Stiffener Weldment.



Photo 17-17 Placing Upper Leg directly under Base Stiffener Weldment.

17.7. Upper Legs. continued

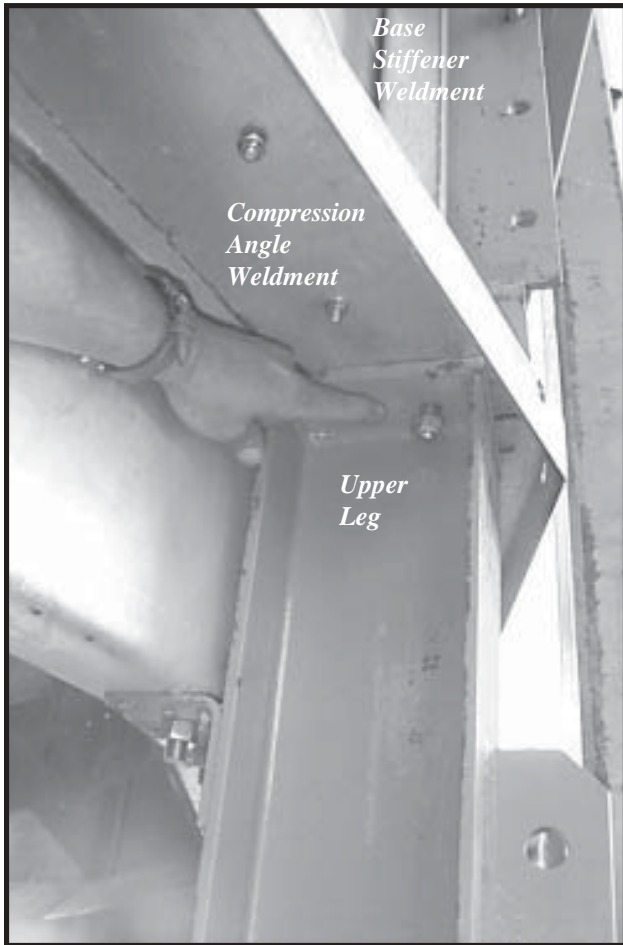

Photo 17-18 Underside View - Upper Leg is bolted through Compression Angle to Base Stiffener Weldment.

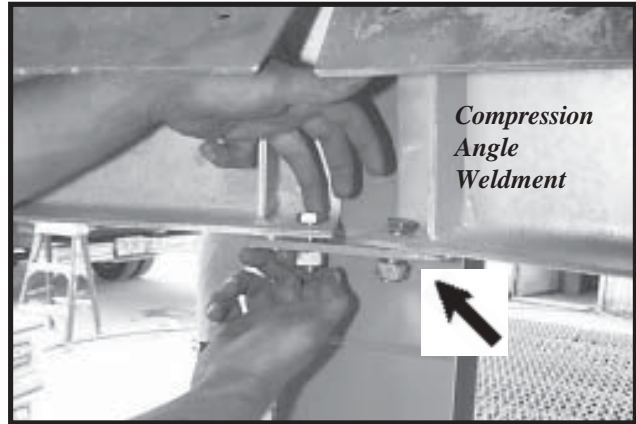

Photo 17-19 Bolting Support Clip on Upper Leg (arrow) to Compression Angle Weldment.

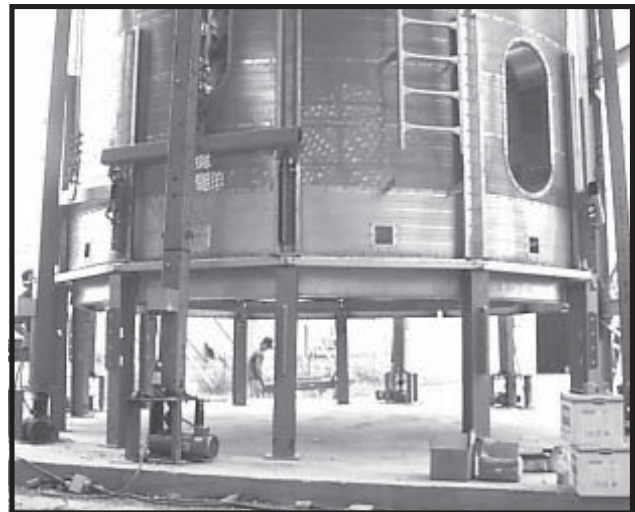

Photo 17-20 Upper Legs are installed.

17.8. Lower Leg.

Lower Legs are installed **AFTER** Outside Hopper Panels are installed.

See Illustration 17-2 for placement of Lower Legs.



Bolt Lower Leg directly below each Upper Leg. Use (2) 5/8" x 2" Grade 8 bolts, (2) 5/8" nuts, and (2) 3/4" washers. Insert bolts down, with (1) washer above and (1) washer below flange on Legs.



Photo 17-21 Bolting Lower Leg to Upper Leg.

17.9. Adjust Dryer to Round & Vertical.

Dryer must be round at the base and vertical along its entire length.

All 18' Dryers are 9"-1" from center to middle of Leg. Measure each Leg and adjust as necessary to bring Legs into position.

Adjust Dryer as required to make entire length of Dryer vertical.
(Photos 17-22 to 17-23)



**IT IS IMPORTANT
ENTIRE LENGTH OF DRYER
IS VERTICAL.**

Vertical is perpendicular to the horizon.



Check by sighting dryer from distance. Also measure with level-transit, surveyor's level, transom, or plumb line.



Photo 17-22 Sighting from a distance to check entire length of dryer is vertical.

17.9. Adjusting Dryer to Round & Vertical. continued



Photo 17-23 Tapping Dryer Legs into position.

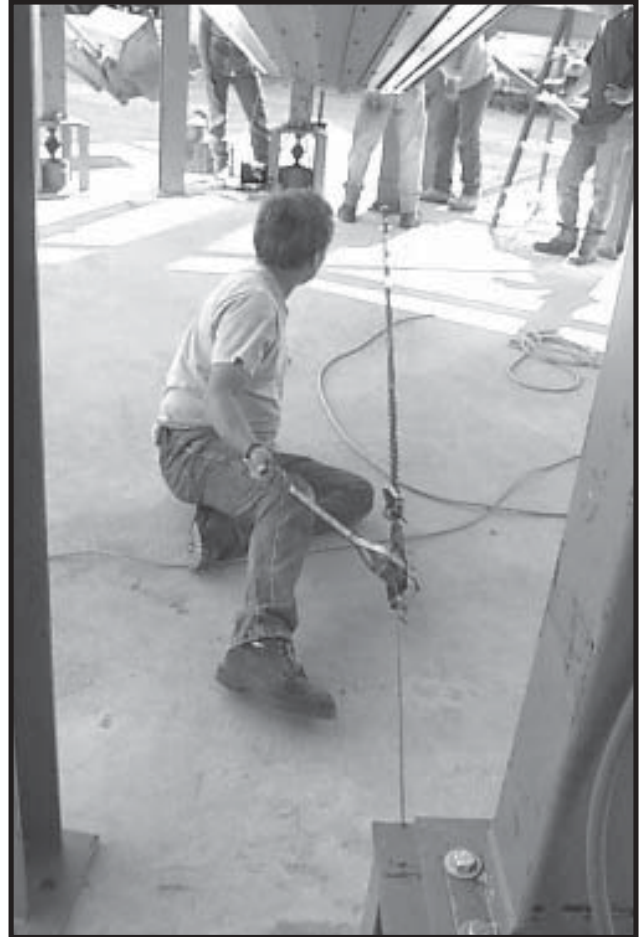

Photo 17-24 Winching dryer legs into position.



Photo 17-25 Dryer Legs are installed.
Dryer is round and vertical.

17.10. Anchoring Dryer Legs.

When Dryer is round & vertical, anchor Lower Legs to Dryer Foundation as follows.



Use supplied HILTI HAS Anchor Bolts.



Drill out bolt holes in base of Lower Leg. See manufacturer's instruction sheet for proper size hole to securely anchor Dryer.

Install bolts to bolt holes at base of Lower Leg with Ceramic Epoxy.



Apply Ceramic Epoxy and set Anchor Bolts according to manufacturer's instructions. See manufacturer's MSDS (Material Safety Data Sheet) for safety hazards and precautions.



Photo 17-27 Ceramic Epoxy Injection Tool.



Photo 17-28 Ceramic Epoxy Injection Tool Cartridge.

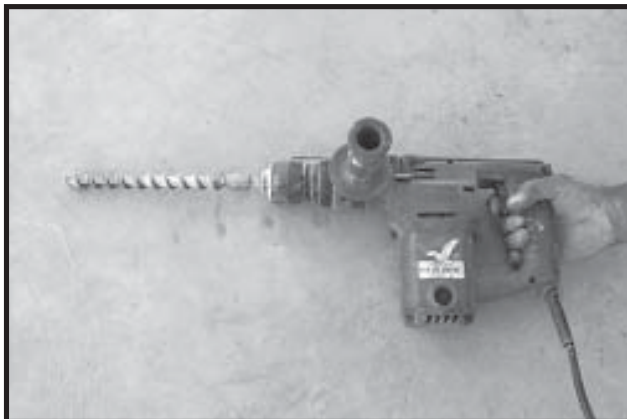

Photo 17-26 Hammer Drill and Bit.



Photo 17-29 Ceramic Epoxy Injection Tool Nozzle.

17.10. Anchoring Dryer Legs. continued

Follow manufacturer's instructions to apply Ceramic Epoxy.



Photo 17-30 Drill proper size hole.

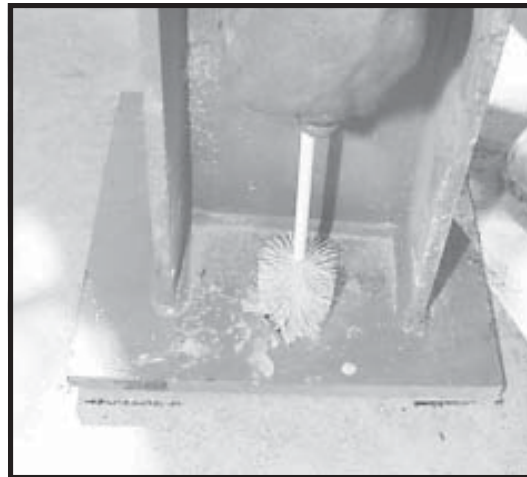

Photo 17-31 Clean out hole.

IMPORTANT: thoroughly clean all debris out of drilled hole for proper epoxy adhesion.



Photo 17-32 Fill hole with Ceramic Epoxy.

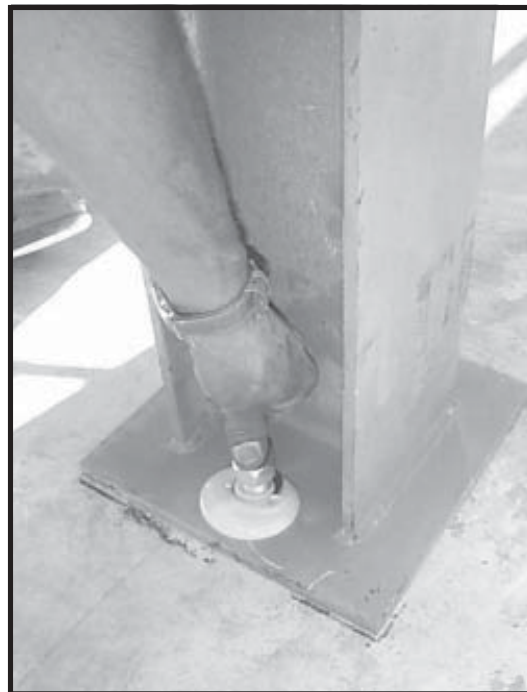

Photo 17-33 Insert HILTI HAS Anchor Bolt. Move bolt up and down several times to remove air pockets from epoxy.

17.11. X-Bracing Rods.

See Illustration 17-3, “X-Bracing Rods” for placement.

Secure X-Bracing Rods to Dryer Legs with 3/4” nut, 3/4” washer, and cast washer as shown in Photo 17-37.



*Photo 17-34
Installing X-Bracing Rods to Dryer Legs.*



Photo 17-35 X-Bracing Rods.



Photo 17-36 Cast Washer.

17.11. X-Bracing Rods. continued



Photo 17-37 Secure X-Bracing Rods with 3/4" nut, 3/4" washer, and cast washer (arrow).

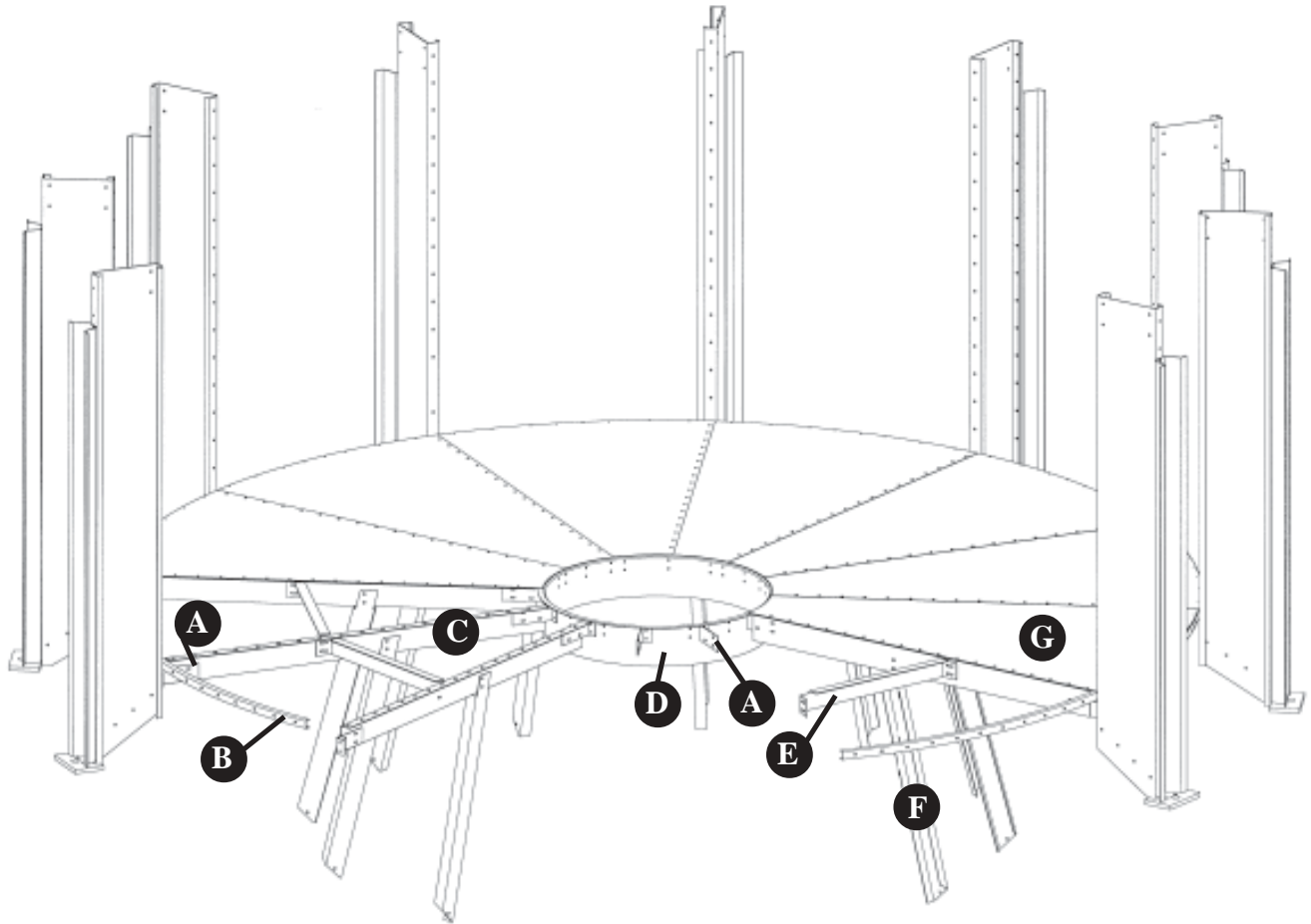

Photo 17-38 X-Bracing Rods installed.

Illustration 18-1

Cool Section Floor

Example - All Models



Parts

Hardware

(A) Cool Section Floor Beam Brackets	5/16" x 3/4" whiz lock bolts & nuts
(B) Rolled Plenum Channels	5/16" x 3/4 whiz lock bolts & nuts
(C) Cool Section Floor Beams	5/16" x 3/4" whiz lock bolts & nuts
(D) Cool Section Floor Center Collar	5/16" x 3/4" slotted truss head bolts & 5/16" whiz lock nuts
(E) Cool Section Floor Crossbeams	5/16" x 3/4" whiz lock bolts & nuts
(F) Cool Section Floor Supports	<i>(install in later step)</i>
(G) Cool Section Floor Sheets	perimeter - #10 x 1" self-tapping screws & silicon injection caulking seams - 5/16" x 3/4" slotted truss head bolts & 5/16" whiz lock nuts

**Important Safety Precautions:**

Dryer has sharp edges. These sharp edges may cause serious injury. Use appropriate Personal Protective Equipment. Use proper lifting techniques.



See Chapter 1 “Orientation” for dryer dimensions, components, wall sheet guidelines, etc. See Appendices for “Tools and Equipment”, “Hardware”, etc.

18. Cool Section Floor

18.1. Cool Section Floor Beam Brackets.



Cool Section Floor Beam Brackets face same way around perimeter, and mirror each other across Cool Section floor.



In previous step, Cool Section Floor Beam Brackets were installed to each Vertical Base Channel through Inside Solid Wall Sheet. (Photo 18- 1)

Snug bolt (1) Cool Section Floor Beam Bracket to each Cool Section Floor Beam.

18.2. Rolled Plenum Channels.

Bolt last ring of Rolled Plenum Channels on Inside Solid Wall Sheet, above Cool Section Floor Beam Brackets in pre-drilled bolt holes. (Photo 18- 1)



This ring of Rolled Plenum Channels is outer edge of support for Cool Section Floor Sheets.

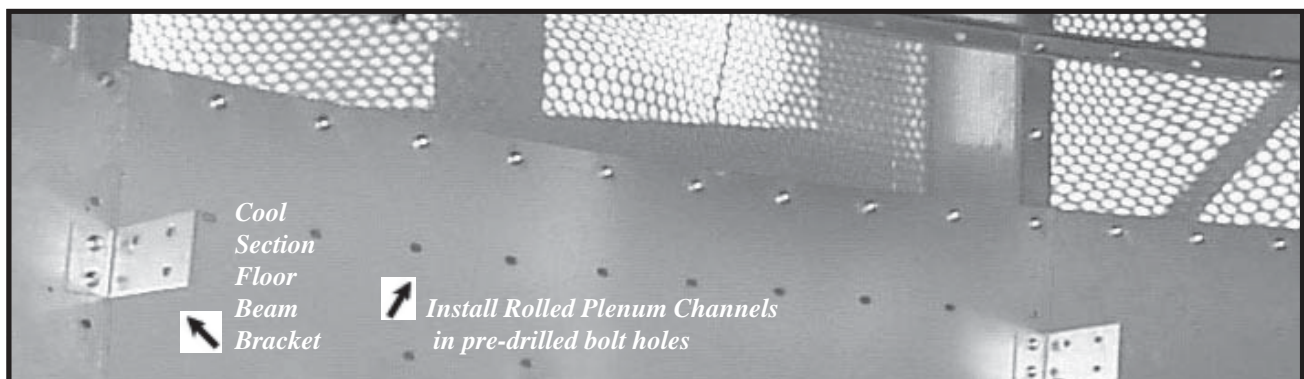

Photo 18-1



Tighten bolts in Cool Section Floor after Hopper and Metering Drum are installed.

When tightening bolts in Cool Section Floor, start at center of each floor sheet and work to edges to avoid buckling

18.3. Cool Section Floor Beams & Cool Section Floor Center Collar.



Install Cool Section Floor Center Collar and Cool Section Floor Beams with flange side up.

From opposite sides of dryer, bring a pair of Cool Section Floor Beams to Cool Section Floor Center Collar in center of dryer. Hold level and snug bolt. Install remaining pairs of Cool Section Floor Beams in same way, from opposite sides of dryer and holding level.



Check Cool Section Floor is level.

18.4. Cool Section Floor Crossbeams.

Snug bolt Cool Section Floor Crossbeams (with flange side up) between Cool Section Floor Beams.

18.5. Hoist Metering Drum.

After Cool Section Floor Beams, Center Collar, and Crossbeams are snug bolted in place, temporarily hoist Metering Drum to just below Cool Section Floor Center Collar. This will position Metering Drum for later installation.

18.6. Cool Section Floor Sheets.

Snug bolt all Cool Section Floor Sheets except for one. In later step, this opening will give access to build Hopper, and to pass parts through.

18.7. Storing Parts.

Temporarily store parts for Hopper construction and Metering Drum installation on Cool Section Floor. For example: bring in Inside Hopper Sheets, Divider Hopper Channels, Cool Section Floor Supports, Metering Drum Motor, Gearbox, and Brackets for Metering Drum.

18.8. Hopper Service Door.

To install Hopper Service Door to center of Cool Section Floor, see Step 16.8.

18.9. Cool Section Floor Supports.

Install Cool Section Floor Supports in later step (during Hopper construction).

18.10. Caulking.

After Hopper and Metering Drum are installed, and Cool Section Floor bolts are tight, run a bead of silicone injection caulking around (top) outside edge of floor. Fill gap between Cool Section Floor Sheets and inside wall of Dryer.



A good seal is important to reduce dust in Cool Section.

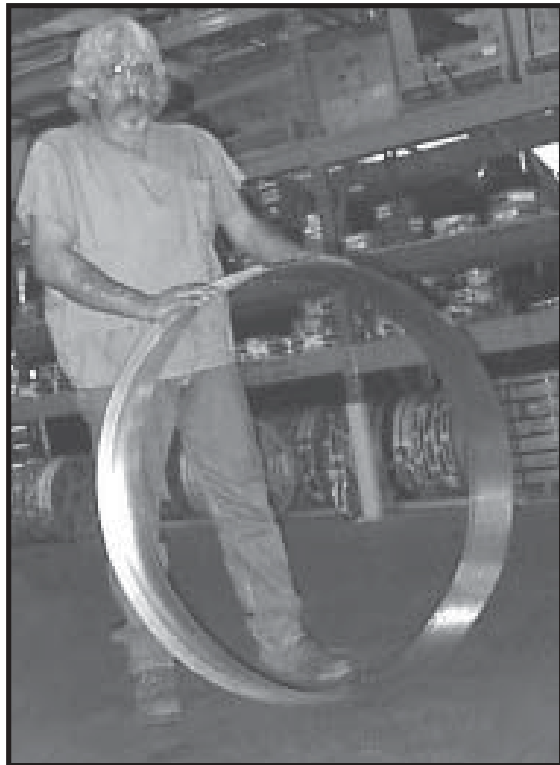

Photo 18-2 Cool Section Floor Center Collar.

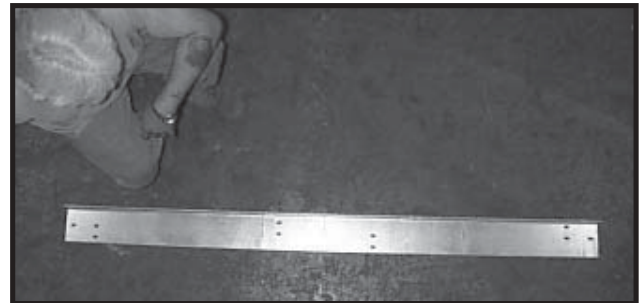

Photo 18-4 Cool Section Floor Beam.

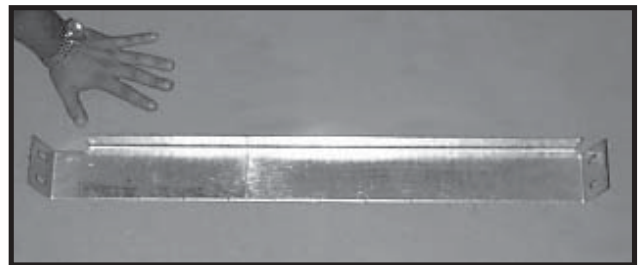

Photo 18-5 Cool Section Floor Crossbeam.



Photo 18-3 Cool Section Floor Sheet.



Photo 18-6 Installing last ring of Rolled Plenum Channel.



Photo 18-7 Snug bolting Cool Section Floor Beam to Cool Section Floor Beam Bracket (on Inside Solid Wall Sheet).

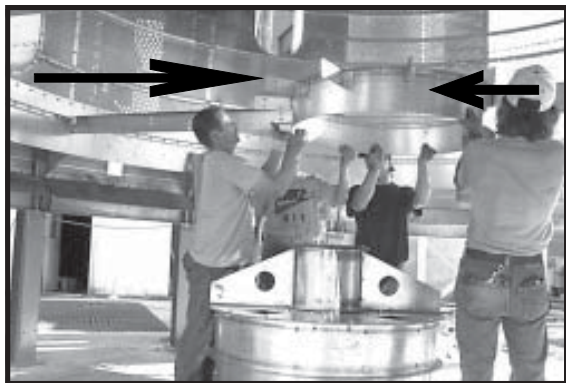

Photo 18-8 Bringing first pair of Cool Section Floor Beams (arrows) to Cool Section Floor Center Collar.



Photo 18-9 Close up - Bringing Cool Section Floor Beam to Cool Section Floor Center Collar.



Photo 18-10 Aligning Cool Section Floor Beam Bracket to Cool Section Floor Center Collar.



Photo 18-11 Snug bolting pairs of Cool Section Floor Beams to Cool Section Floor Center Collar.



Photo 18-12 Cool Section Floor Crossbeam snug bolted between Cool Section Floor Beams.

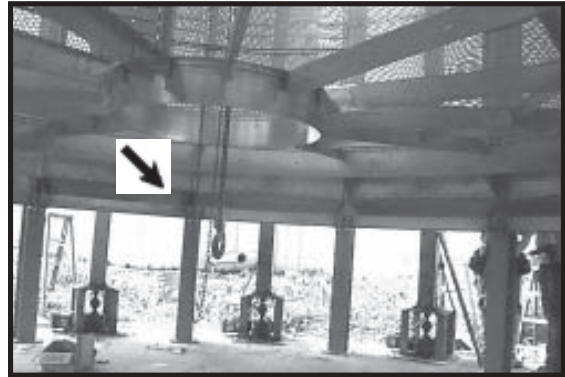

Photo 18-13 Cool Section Floor Center Collar, Beams, and Crossbeams snug bolted. Arrow indicates hoisting tackle to lift metering drum.



Photo 18-14 Moving Metering Drum into center of dryer (under Cool Section Floor Center Collar).



Photo 18-15 Securing Metering Drum for hoisting.

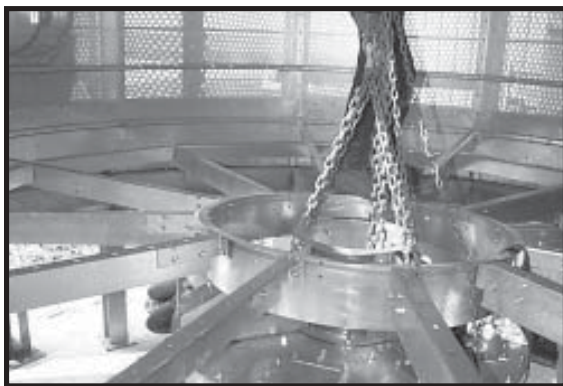

Photo 18-16 Hoisting Metering Drum under Cool Section Floor Center Collar.



Photo 18-17 Placing Cool Section Floor Sheets.



Photo 18-18 View from below - Placing Cool Section Floor Sheets.



Photo 18-19 Aligning Cool Section Floor Sheets.



Photo 18-20 Snug bolting Cool Section Floor Sheets.



Photo 18-21 Temporarily store parts for Hopper and Metering Drum on Cool Section Floor.



Photo 18-22 Tightening self tapping screws on perimeter of Cool Section Floor.



Photo 18-23 Caulking outside edge of Cool Section Floor.

Hopper 19

Illustration 19-1

Hopper (cross section)

Example - All Models

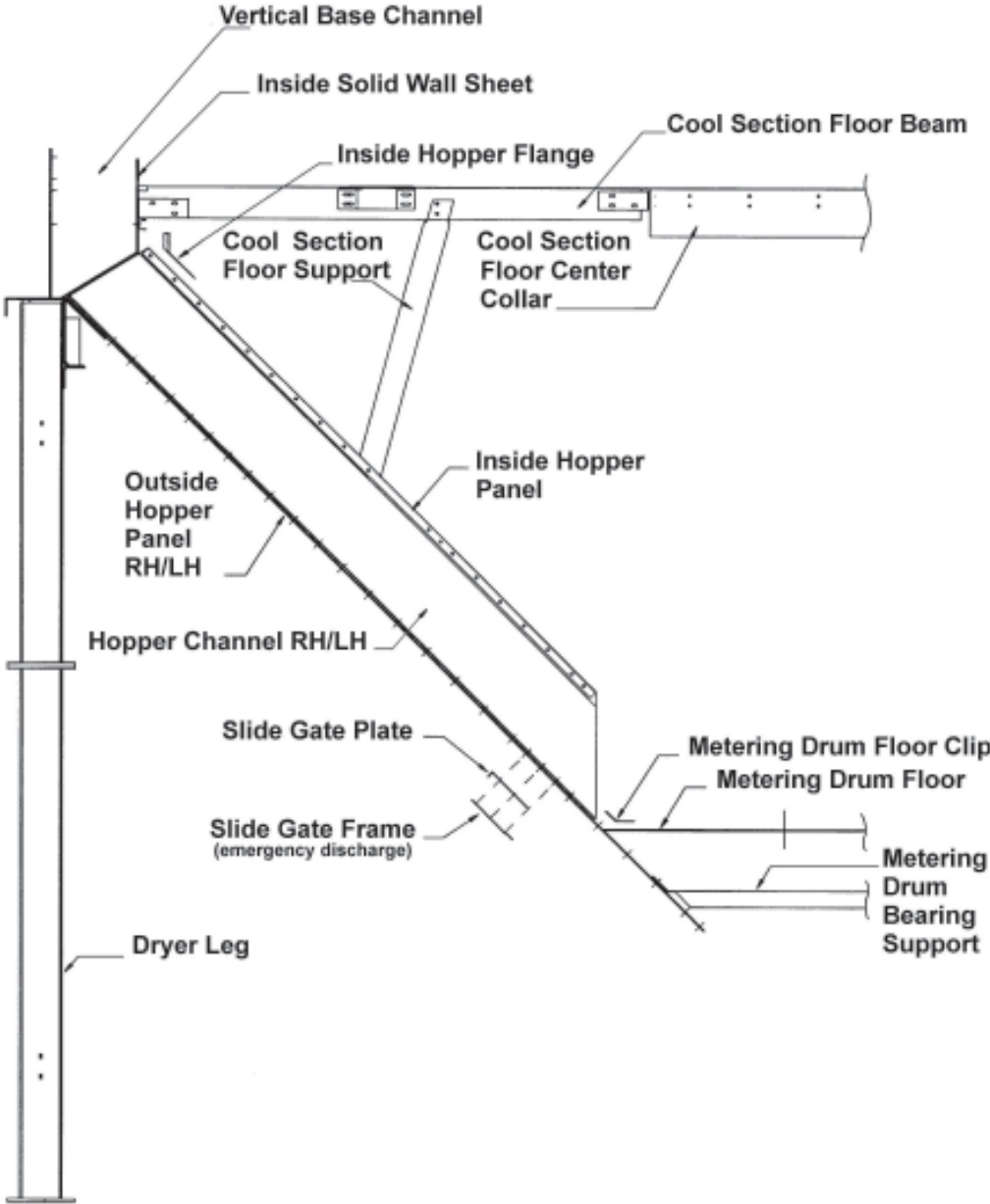

**Important Safety Precautions:**

Dryer has sharp edges. These sharp edges may cause serious injury. Use appropriate Personal Protective Equipment. Use proper lifting techniques.



See Chapter 1 “Orientation” for dryer dimensions, components, wall sheet guidelines, etc. See Appendices for “Tools and Equipment”, “Hardware”, etc.

19. Hopper

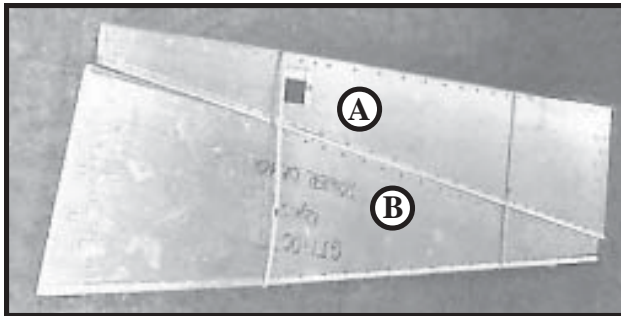

Photo 19-1

- (A) Outside Hopper Panel - RH
with cutout for Slide Gate
(for emergency grain discharge)
- (B) Outside Hopper Panel - LH

Lapping Outside Hopper Panels

Lap Outside Hopper Panel-RH with cutout on outside of dryer so Slide Gate will slide freely.

Outside Hopper Panels flat edges - lap together and bolt.

Outside Hopper Panels angled edges - lap together, then bolt under Hopper Channels with common bolts.

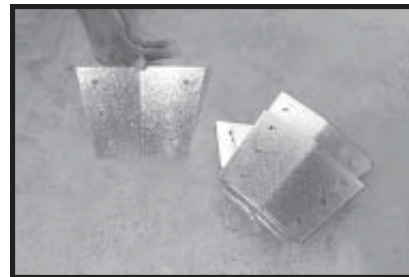

Photo 19-2 Compression Angle Splices.

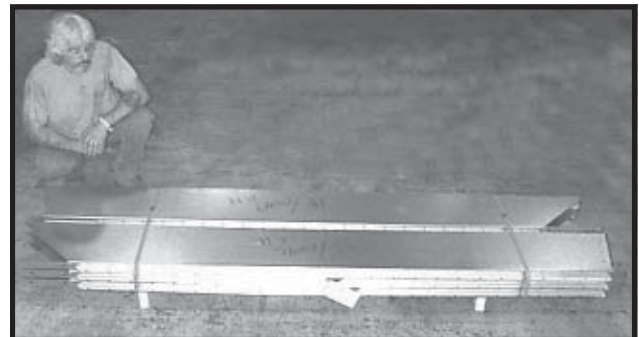

Photo 19-3 Hopper Channels, RH and LH.
Install with diagonal-cut end down.
Bottom side has horizontal flange.
Top side has vertical flange.

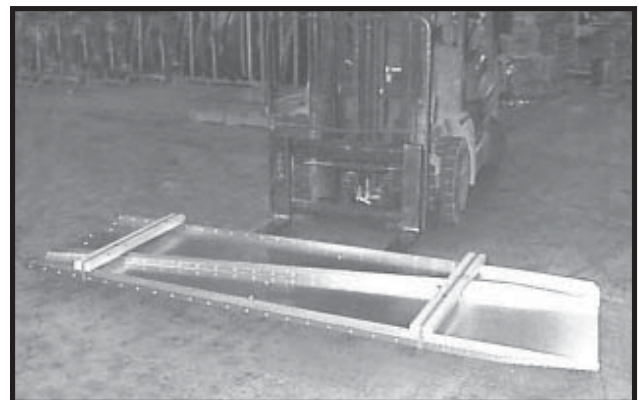

Photo 19-4 Inside Hopper Panels
(under wood shipping blocks).



Photo 19-5 Inside Hopper Flange.



Photo 19-6 Hopper Discharge Weldment.

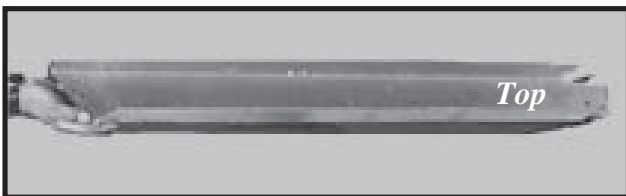

Photo 19-7 Cool Section Floor Support.
Bolt square-cut end to Cool Section Floor Beam.
Bolt diagonal-cut end to Hopper Channel
(through Inner Hopper Panels.)

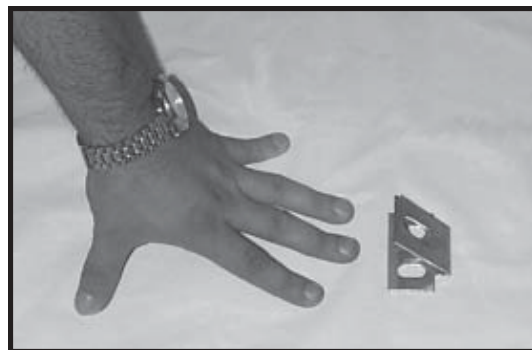

Photo 19-8 Metering Drum Floor Clip.



Photo 19-9 Metering Drum Floor.

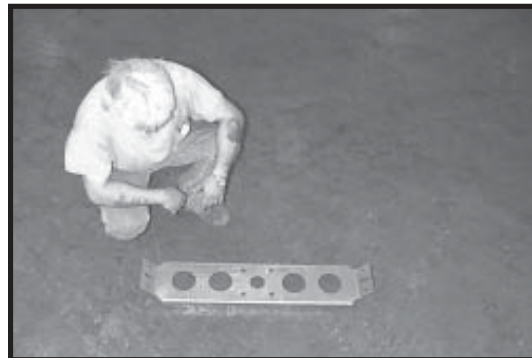

Photo 19-10 Metering Drum Bearing Support.



Insert bolts away from Hopper, with head of bolt between Outside and Inside Hopper Panels.



Until fully installed, secure Outside Hopper against wind, especially overnight.

Hopper Parts

Hardware & Installation Notes

Outside Hopper Panels (RH/LH) Compression Angles and through Compression Angle Splices	3/8" x 1", grade 5 bolts and nuts (See photos for additional installation notes.) (Lift dryer to free Outside Hopper Panels.)
Outside Hopper Panel (LH/RH) seams	1/2" x 1", grade 5 bolts and nuts (Install LH & RH panels in pairs that mirror each other. First bolt every other seam, in other words, bolt flat edged seams. Channels will bolt over angled edge seams with common bolt.) (Gather lower edges of panels and secure with temporary bolts.) (Install Lower Legs.)
Metering Drum Bearing Support	3/8" x 1", grade 5 bolts and nuts (Level & drill for outside bolts.) (Center bolt is common with Outside Hopper Panel seam.)
Metering Drum Floor Clips	1/2" x 1", grade 5 bolts and nuts (Install on panel seams.)
Metering Drum Floor	1/2" x 3/4" slotted truss head bolts and 5/16" whiz lock nuts (Install to clips & level.) (Silicone caulk Metering Drum Floor.)
Hopper Discharge Weldment to Outside Hopper Panels	1/2" x 1", grade 5 bolts and nuts (Bolt tight. Tighten bottom four bolts on Outside Hopper Panels seams while accessible.)
Hopper Channels (RH/LH) to Outside Hopper Panels (RH/LH)	1/2" x 1", grade 5 bolts and nuts (Install LH & RH Hopper Channels in pairs that bracket each other. Match shape of Hopper Channel to Vertical Base Channel for smooth transition from grain column to Hopper.) (Tighten Outside Hopper.) (Silicone caulk gap between Hopper Panels at Compression Angles, and along vertical length of Compression Angle Splices.)
Pre-assemble (1) Inside Hopper Flange to each Inside Hopper Panel	5/16" x 3/4" whiz lock bolts and nuts
Inside Hopper Panels to Hopper Channels	3/8" x 1", grade 5 bolts and nuts
Inside Hopper Flange to Inside Solid Wall Sheet	5/16" x 3/4" whiz lock bolts and nuts (Bolt tight.)
Cool Section Floor Support to Cool Section Floor Beam	5/16" x 3/4" whiz lock bolts and nuts (Pre-drilled bolt holes in Cool Section Floor Beams will position support.)
Cool Section Floor Support to Hopper Channel (through Inside Hopper Panel)	3/8" x 1, grade 5 bolts and nuts (Lower Metering Drum.) (Tighten Inside Hopper and supports.)
Slide Gate Frame to Outside Hopper Panel-RH	5/16" x 3/4" whiz lock bolts and nuts
Slide Gate Panel	Insert in Slide Gate Frame.

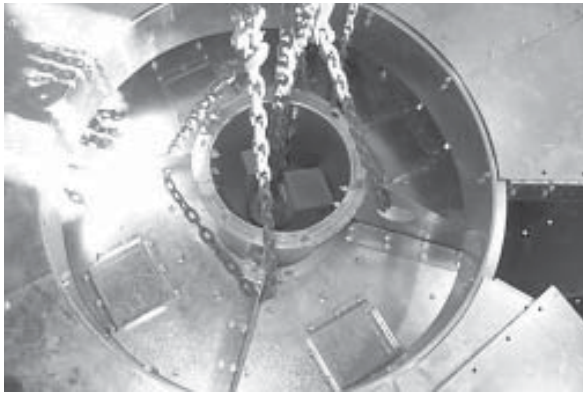

Photo 19-11 Metering Drum is hoisted before Hopper is installed. Note access opening in Cool Section Floor (arrow).



Photo 19-12 In Photo, to demonstrate orientation, Compression Angle Splice (arrow) is temporary bolted to Compression Angles. In actual installation, use common bolt to install Outside Hopper Panels (over Compression Angle Splice) to Compression Angles.



Photo 19-13 View from above - Bolting Outside Hopper Panels over Compression Angles and Compression Angle Splices.



Photo 19-14 View from below - Bolting Outside Hopper Panels over Compression Angles and Compression Angle Splices.



Photo 19-16 Aligning Outside Hopper Panels.



Photo 19-17 While installing Outside Hopper Panels, allow ends to overlap at center of dryer.

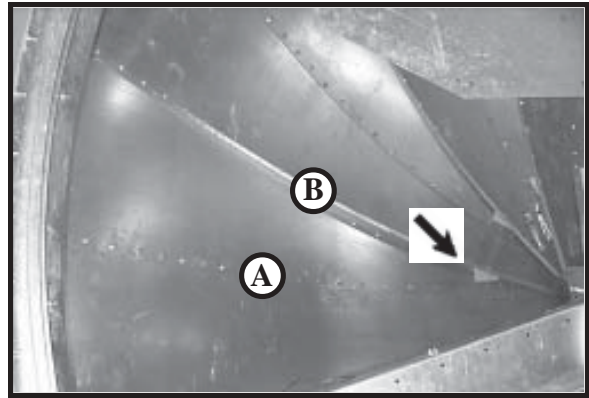

Photo 19-18 Close up - bolting Outside Hopper Panels (RH/LH). Lap Outside Hopper Panels-RH with cutout (arrow) on outside of dryer so Slide Gate will slide freely. (A) Bolt flat edges together. (B) Angled edges will bolt together later, under Hopper Channel with common bolt.

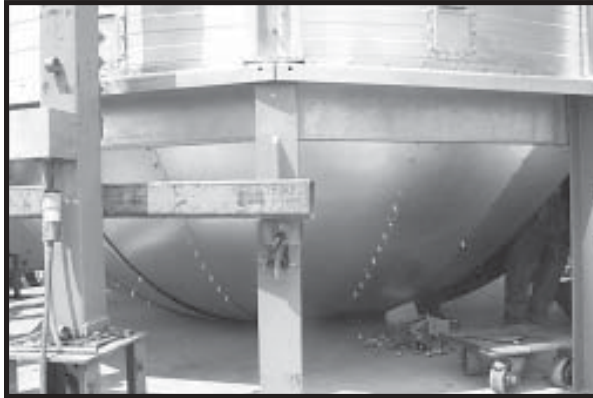

Photo 19-19 Installing Outside Hopper Panels



Photo 19-20 Bring Metering Drum Floor into Outside Hopper before closing in with last panel.



Photo 19-21 **Important** - After all Outside Hopper Panels are in place, secure against wind with temporary bolts, especially overnight.



Photo 19-22 Aligning Outside Hopper Panels before installing Hopper Discharge Weldment.



Photo 19-23 Aligning Hopper Discharge Weldment to Outside Hopper Panels.

Photo 19-24 Drilling (2) outside bolt holes at each end of Metering Drum Bearing Support. Note center bolt hole (arrow) is bolted with common bolt to a flat edged Outside Hopper Panel seam. Check for level.

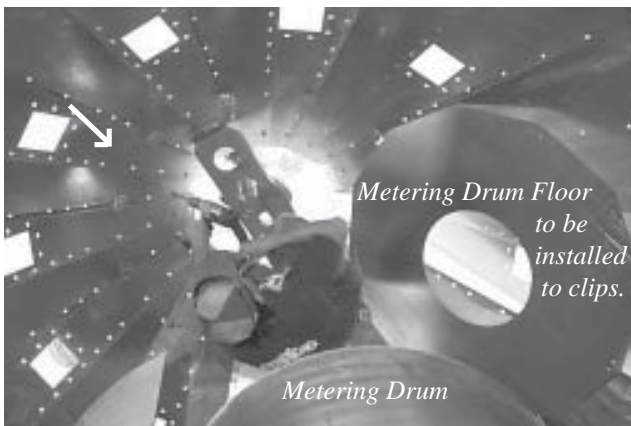

Photo 19-25 Installing Metering Drum Floor Clips (arrow) around bottom perimeter of Outside Hopper.



Photo 19-26 Installing Metering Drum Floor to underside of Metering Drum Floor Clips. Check for level.

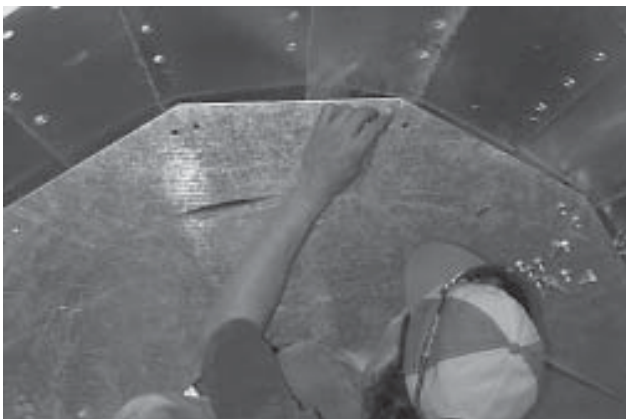

Photo 19-27 Close up - Installing Metering Drum Floor to Metering Drum Floor Clips.



Photo 19-28 Caulking Metering Drum Floor with silicone caulk.



Photo 19-29 Bringing Hopper Channels (RH/LH) into dryer through opening in Cool Section Floor.



Photo 19-30 View from above - RH and LH Hopper Channels bracket each other (arrow).



Photo 19-31 View from above - Installing RH and LH Hopper Channels to bracket each other.



Photo 19-32 View from below - Installing RH and LH Hopper Channels.



Photo 19-33 Snug bolt all RH/LH Hopper Channels in place, then tighten.



Photo 19-34 Pre-assembling (1) Inside Hopper Flange to each Inside Hopper Panel.

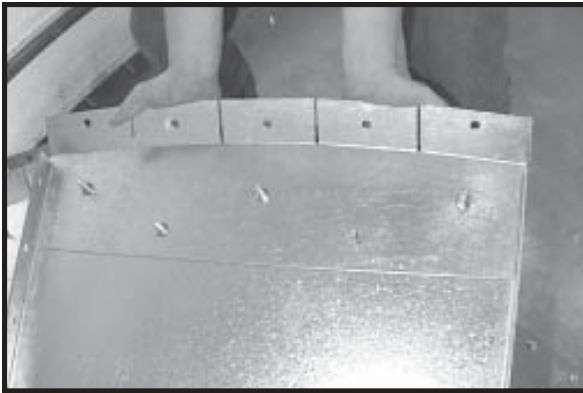

Photo 19-35 Close up - Inside Hopper Flange bolted to Inside Hopper Panel.



Photo 19-36 Accessing Hopper through opening in Cool Section Floor.



Photo 19-37 Installing Inside Hopper Panels to Hopper Channels.



Photo 19-38 Bolting Inside Hopper Flange to Inside Solid Wall Sheet.



Photo 19-39 Bolting Cool Section Floor Support to Cool Section Floor Beam.

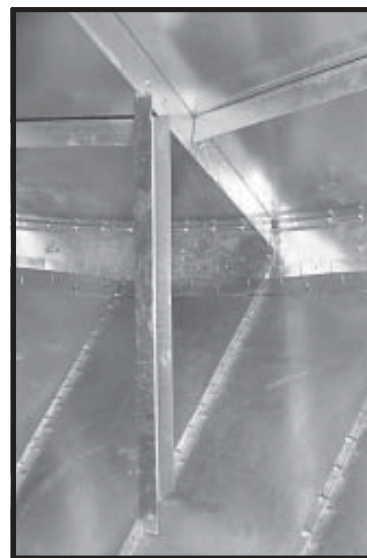

Photo 19-40 Cool Section Floor Support installed.



Photo 19-41 View from above - Tightening Inside Hopper Panels.

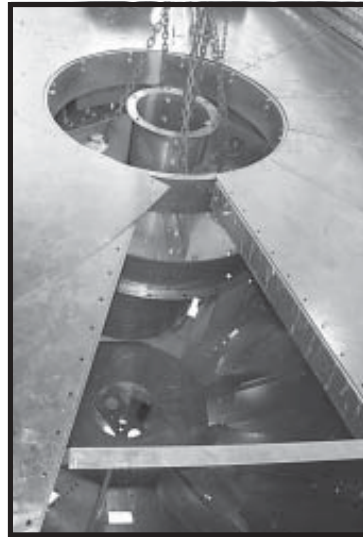

Photo 19-42 After Inside Hopper bolts are tight, close Cool Section Floor.



Photo 19-43 Closing Cool Section Floor.



Photo 19-44 Hopper installed with Emergency Discharge Slide Gates (See Step 10, "Slide Gates".)

Metering System 20

Example - All Models

Illustration 20-1
Metering System (installed)

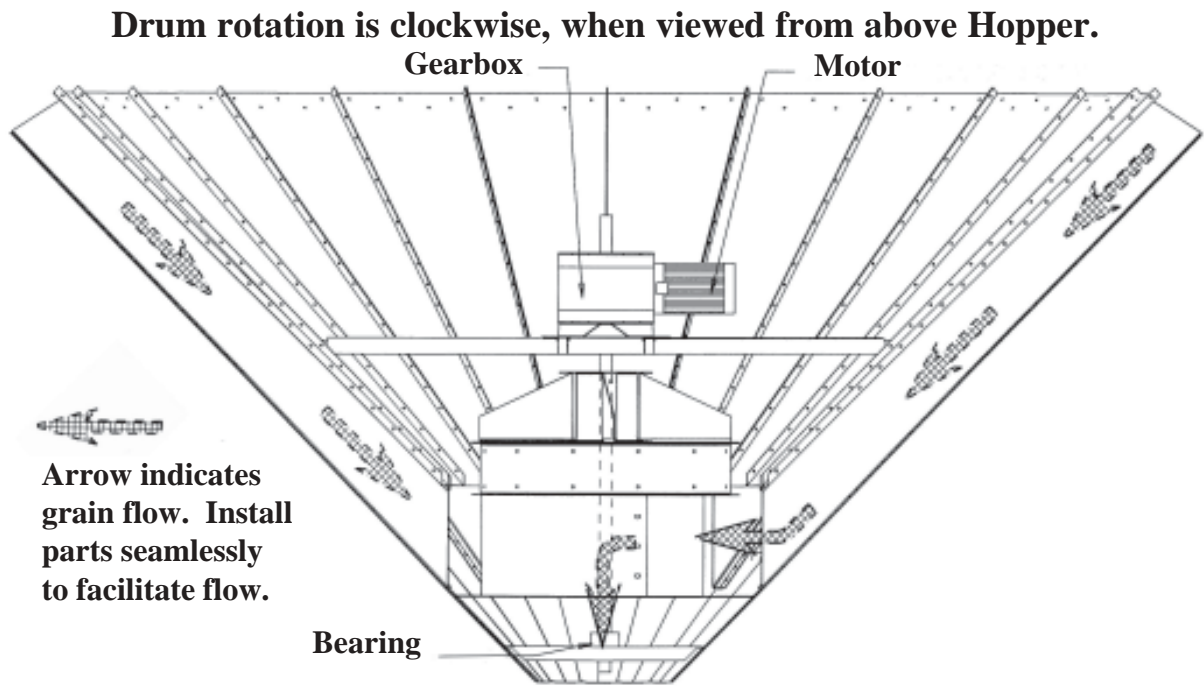

Illustration 20-2
Gearbox Supports

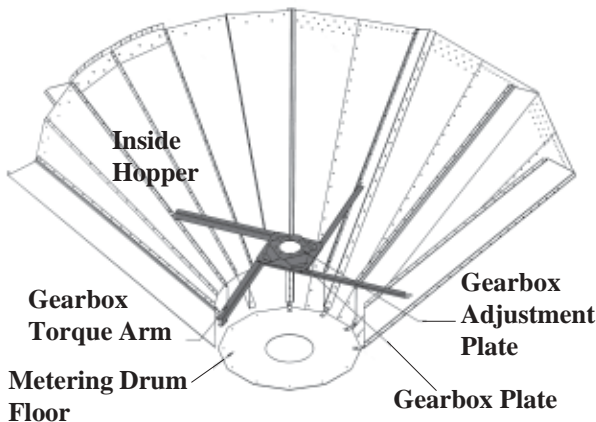
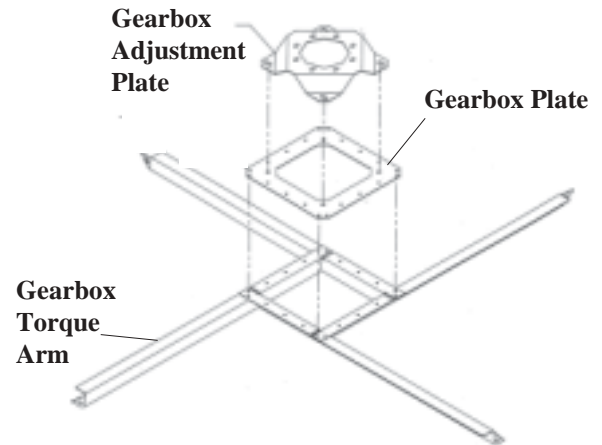

Illustration 20-3
Gearbox Supports (expanded view)



**Important Safety Precautions:**

Dryer has sharp edges. These sharp edges may cause serious injury. Use appropriate Personal Protective Equipment. Use proper lifting techniques.



See Chapter 1 “Orientation” for dryer dimensions, components, wall sheet guidelines, etc. See Appendices for “Tools and Equipment”, “Hardware”, etc.

20. Metering System



Photo 20-1 Metering Drum.



Photo 20-2 Metering Drum Motor as shipped.

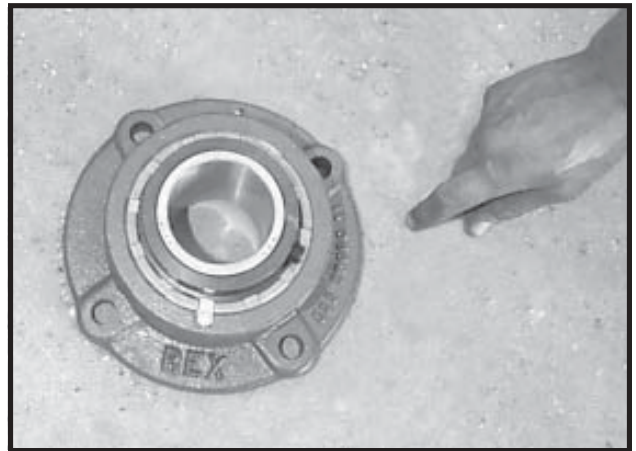

Photo 20-3 Metering Drum Bearing.



Photo20-4 Gearbox Torque Arm.

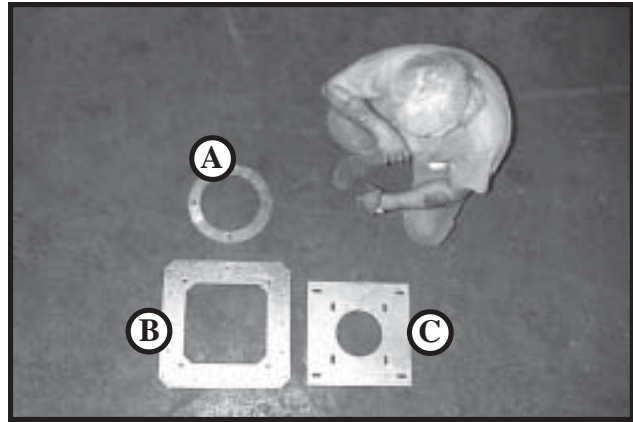

Photo 20-5



Photo 20-6 Metering Drum Drive Shaft Weldment 6' (2-3/8"). Note Grain Deflector (arrow) is over Bearing Thrust Collar.

(A) Gearbox Adaptor Plate.

(B) Gearbox Plate.

(C) Gearbox Adjustment Plate.

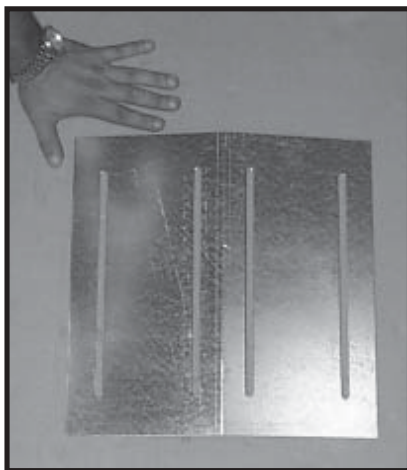

Photo 20-7 Metering Drum Baffle.



Photo 20-8 Metering Drum Baffle Clip.



Photo 20-9 Metering Drum Gearbox (90:1).

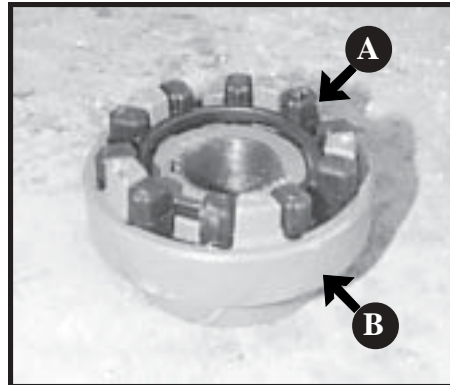

Photo 20-10 Half of Flexible Coupler - 2 parts.
(Other half of Flexible Coupler is pre-installed on Gearbox.)

- (A) Motor Shaft Coupling Insert
- (B) Motor Shaft Coupling Body



Photo 20-11 Gearbox Set Collar 2-3/8".

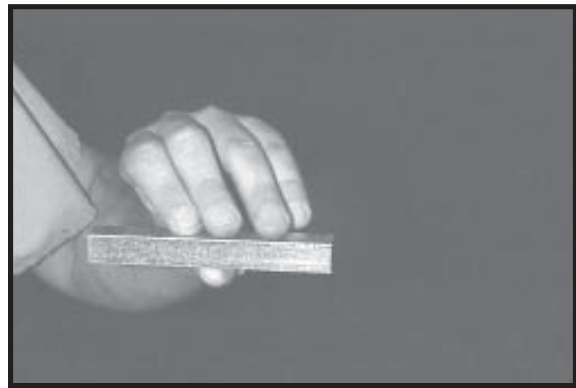

Photo 20-12 5/8" x 5/8" x 5" Metering Drum Drive Shaft Key.

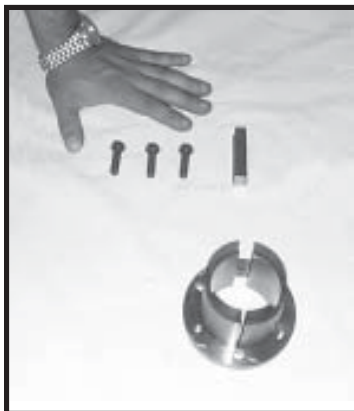

Photo 20-13 Q1 Taper Bushing with 2-3/8" bore, key and setscrews.



Photo 20-14 Amoco Perma Gear 220 or equivalent lubricant for Gearbox. (5 Gallon).

20. Metering System.

20.1. Remove any burrs, pits, and corrosion from Metering Drum Drive Shaft Weldment. (Photo 20-15)

20.2. Slide Metering Drum Bearing on Metering Drum Drive Shaft, flush with Bearing Thrust Collar. Tighten setscrew. (Photo 20-16)

20.3. Remove top Metering Drum Hub for installation of Metering Drum Drive Shaft. (Photo 20-17)

20.4. Insert Drive Shaft Weldment up through bottom Metering Drum Hub. Replace top Metering Drum Hub on Drive Shaft. Secure top and bottom Metering Drum Hubs with Q1 Taper Bushings. (Photos 20-18 & 20-19)

20.5. Lower Metering Drum with Drive Shaft onto bearing support.

 Metering Drum should have 1/4" to 1/2" clearance above Hopper Floor.

 Level Metering Drum.

Bolt Metering Drum Bearing to Bearing Support.

 Use 3/8" x 1", grade 5 bolts and nuts.



Photo 20-15 Cleaning Metering Drum Drive Shaft Weldment.

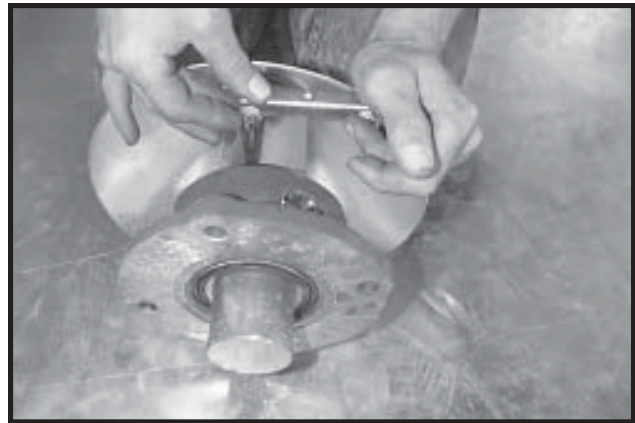

Photo 20-16 Tightening setscrew on Metering Drum Bearing.

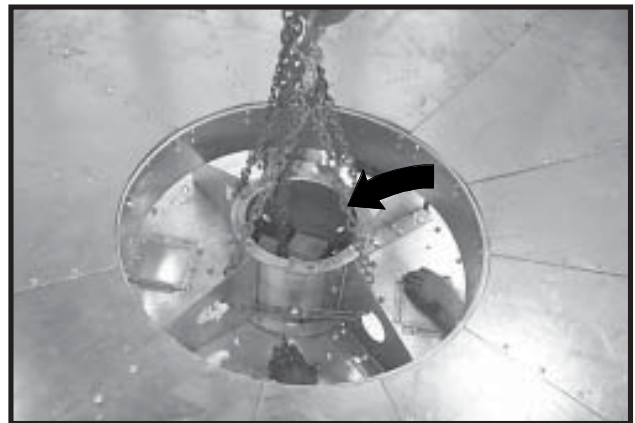

Photo 20-17 Top Metering Drum Hub is removed (arrow) for installation of Metering Drum Drive Shaft.

- 20.6.** Assemble (4) Gearbox Torque Arms and Gearbox Plate as shown in Photos 20-20 & 20-21.



Bolt Gearbox Torque Arms to Inner Hopper with existing bolts. Bolt Gearbox Plate with 1/2" x 1", grade 5 bolts and nuts.

- 20.7.** Slide Gearbox Set Collar (2-3/8") onto Metering Drum Drive Shaft. Do not tighten setscrew yet. (Photo 20-22)

- 20.8.** Apply anti-seize to Metering Drum Drive Shaft as shown in Photos 20-23 & 20-24.

- 20.9.** If necessary, clean out bore of Metering Drum Gearbox. (Photo 20-25)

- 20.10.** Bolt Gearbox Adapter Plate to Metering Drum Gearbox. (Photo 20-26)



Use 1/2" x 1", grade 5 bolts and nuts.

- 20.11.** Bolt Gearbox Adjustment Plate to Metering Drum Gearbox. (Photo 20-27)



Use 1/2" x 1", grade 5 bolts and nuts.

- 20.12.** Lower Metering Drum Gearbox, and slide over Metering Drum Drive Shaft. (Photos 20-28 & 20-29)



Orient Metering Drum Gearbox so Motor will be as close as possible to where Control Box will be outside dryer.

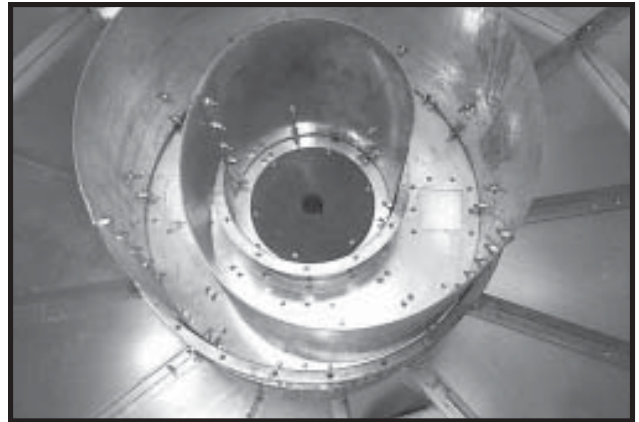

Photo 20-18 View from below Metering Drum.

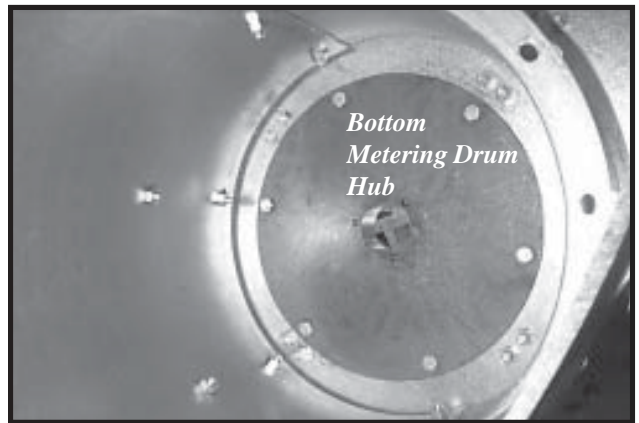

Photo 20-19 Close Up - below Metering Drum.

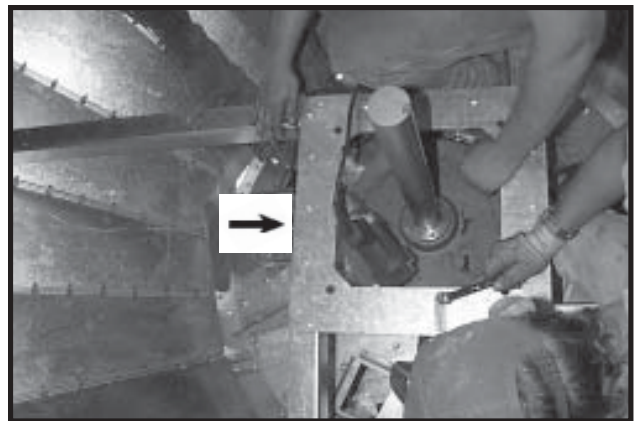

Photo 20-20 Assembling Gearbox Plate (arrow) to Gearbox Torque Arms.

20.12. continued

Align keyways on Metering Drum Gearbox and Metering Drum Drive Shaft. Insert 5/8" x 5/8" x 5" Key.

Bolt Gearbox Adjustment Plate to Gearbox Torque Arm Assembly.



Use 1/2" x 1", grade 5 bolts and nuts.

20.13. Place Motor Shaft Coupling Insert in Motor Shaft Coupling Body to form half of Flexible Coupler. (Other half of Flexible Coupler is pre-installed on Gearbox.)

Place Flexible Coupler half on Metering Drum Motor. Align keyways, and insert Key. Do not tighten setscrew yet. (Photos 20-30 to 20-31)

Place Motor and Gearbox together to check for interference between Flexible Coupler halves. Correct any interference, and tighten setscrew.



Incorrect installation could stress Gearbox and motor bearings, resulting in failure.

Bolt Motor to Gearbox. (Photo 20-32)



Use 3/8" x 1", grade 5 bolts.



Photo 20-21 Gearbox Torque Arm Assembly installed to Inside Hopper Wall.



Photo 20-22 Sliding Gearbox Set Collar (2-3/8") onto Metering Drum Drive Shaft.



Photo 20-23 Applying anti-seize to Metering Drum Drive Shaft.

20.14. Slide Gearbox Set Collar (2-3/8") up Drive Shaft until flush with Gearbox. Tighten setscrew.

20.15. Install Metering Drum Baffle Clips and Metering Drum Baffles. (Photos 20-33 & 20-34)

 Drill and bolt Metering Drum Baffle Clips so they hold Metering Drum Baffles 1" to 1-1/2" from bottom of Inner Hopper Panels.

 Use 5/16" x 3/4" whiz lock bolts and nuts.

20.16. Fill Gearbox lubricant reservoir with lubricant. (Photo 20-35 & 20-36)



Photo 20-24 Applying anti-seize to top of Metering Drum Drive Shaft before installing Gearbox.

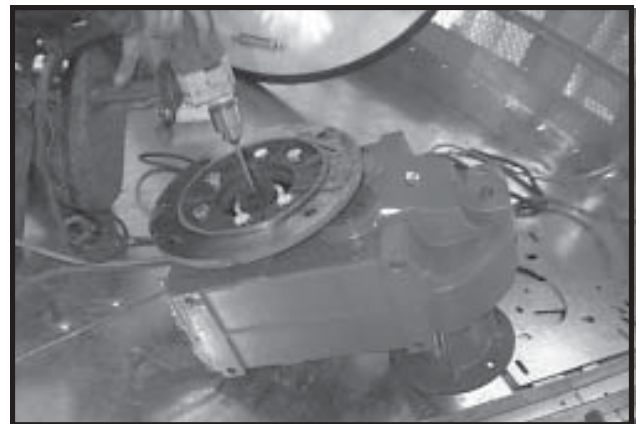



Photo 20-25 Cleaning out bore of Metering Drum Gearbox.

Gearbox Lubrication

Gearbox requires Amoco Perma Gear 220 (or equivalent lubricant). Remove Gearbox lubricant reservoir plug and fill reservoir 1" to 1-1/2" from top. Remove fill hose.

 *Note this is a slow process.*

 *It is very important that no air is left in reservoir. Remove fitting from top of Gearbox. Add a few more ounces of lubricant to Gearbox lubricant reservoir, until lubricant reaches fitting hole.*

 *Replace plug and check for leaks.*

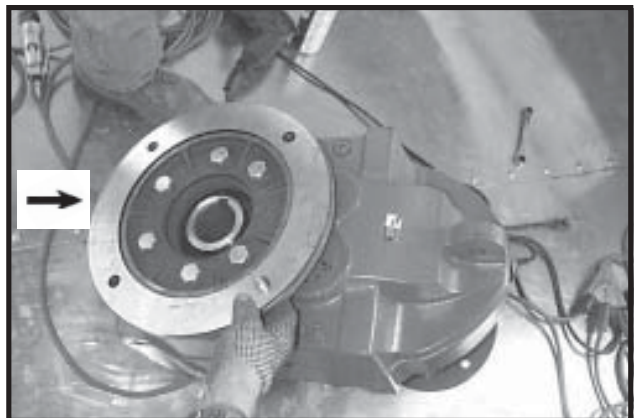

Photo 20-26 Installing Gearbox Adaptor Plate (arrow) to Metering Drum Gearbox.

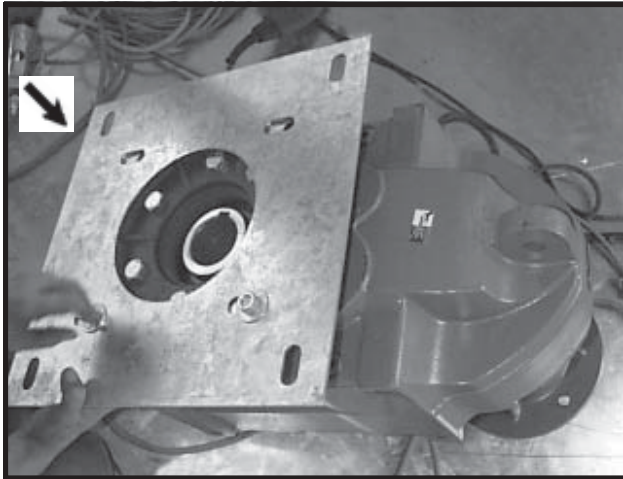

Photo 20-27 Bolting Gearbox Adjustment Plate (arrow) to Metering Drum Gearbox.

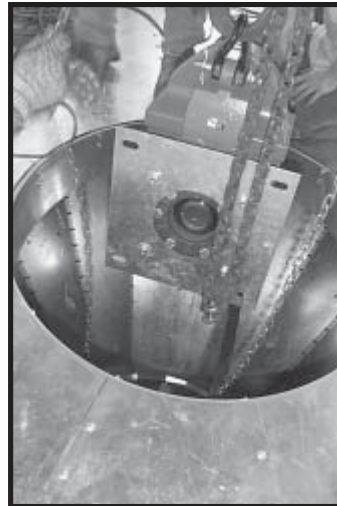

Photo 20-28 Lowering Metering Drum Gearbox over Metering Drum.

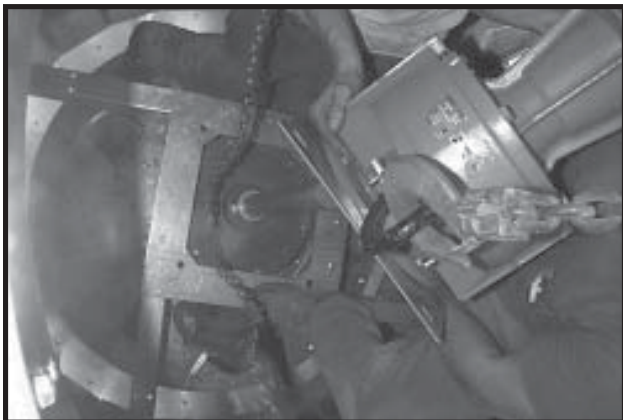

Photo 20-29 Sliding Metering Drum Gearbox over Metering Drum Drive Shaft.

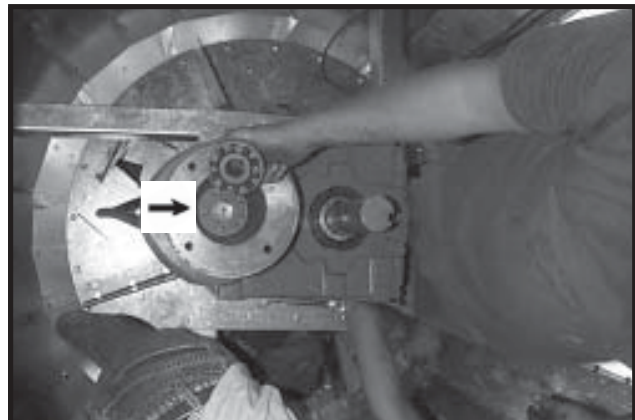

Photo 20-30 Motor Shaft Coupling (with Insert) will match up with pre-installed coupling on Gearbox (arrow).

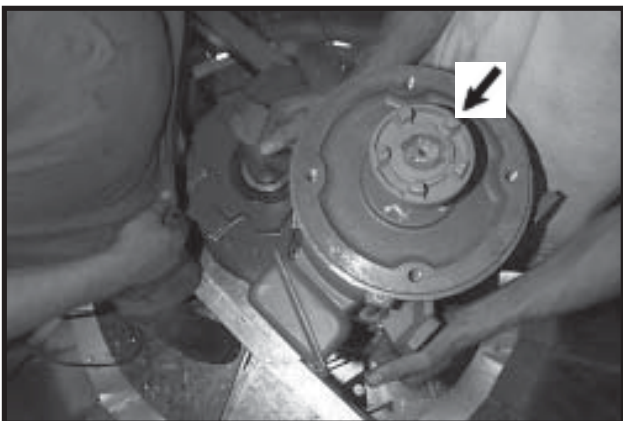

Photo 20-31 Install Motor Shaft Coupling Body (arrow) to Metering Drum Motor, then insert Motor Shaft Coupling Insert (not shown).



Photo 20-32 Bolting Motor to Gearbox (top mount). Note Motor to Gearbox configuration can vary.

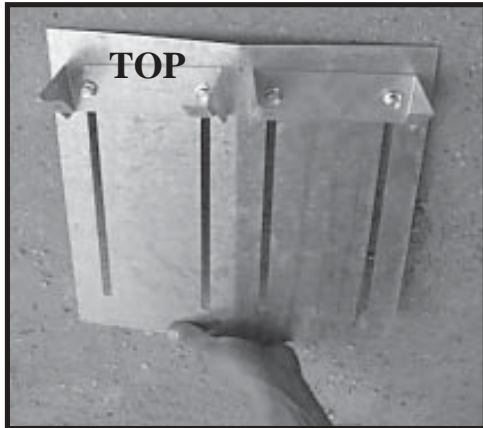

Photo 20-33 In photo, to demonstrate orientation of parts, Metering Drum Baffle Clip is bolted to Metering Drum Baffle. In actual installation, (2) Metering Drum Baffle Clips are installed to each Inside Hopper Panel, then Metering Drum Baffles are installed to Metering Drum Baffle Clips.



Photo 20-34 Metering Drum Baffles installed (arrow).

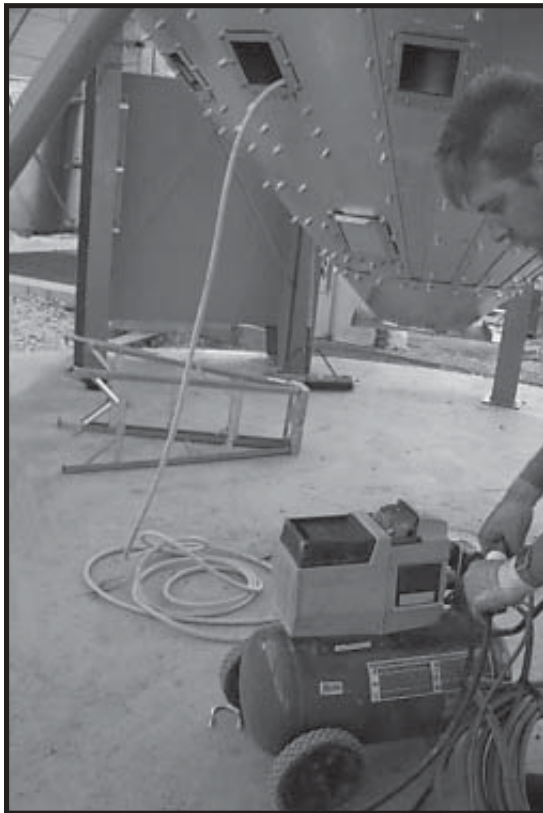

Photo 20-35 Filling Gearbox with Amoco Perma Gear 220 (or equivalent lubricant).

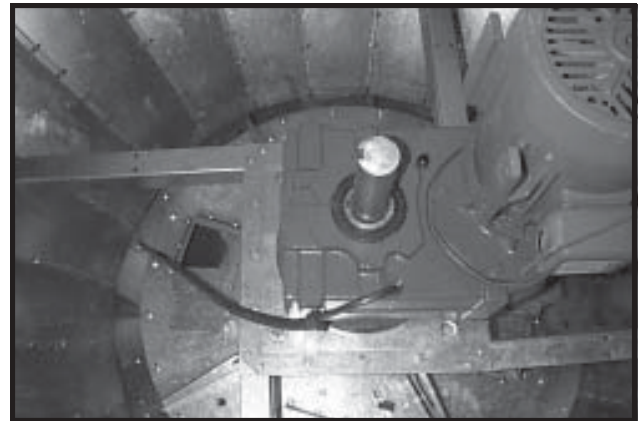

Photo 20-36 Adding lubricant to Gearbox Lubricant Reservoir.

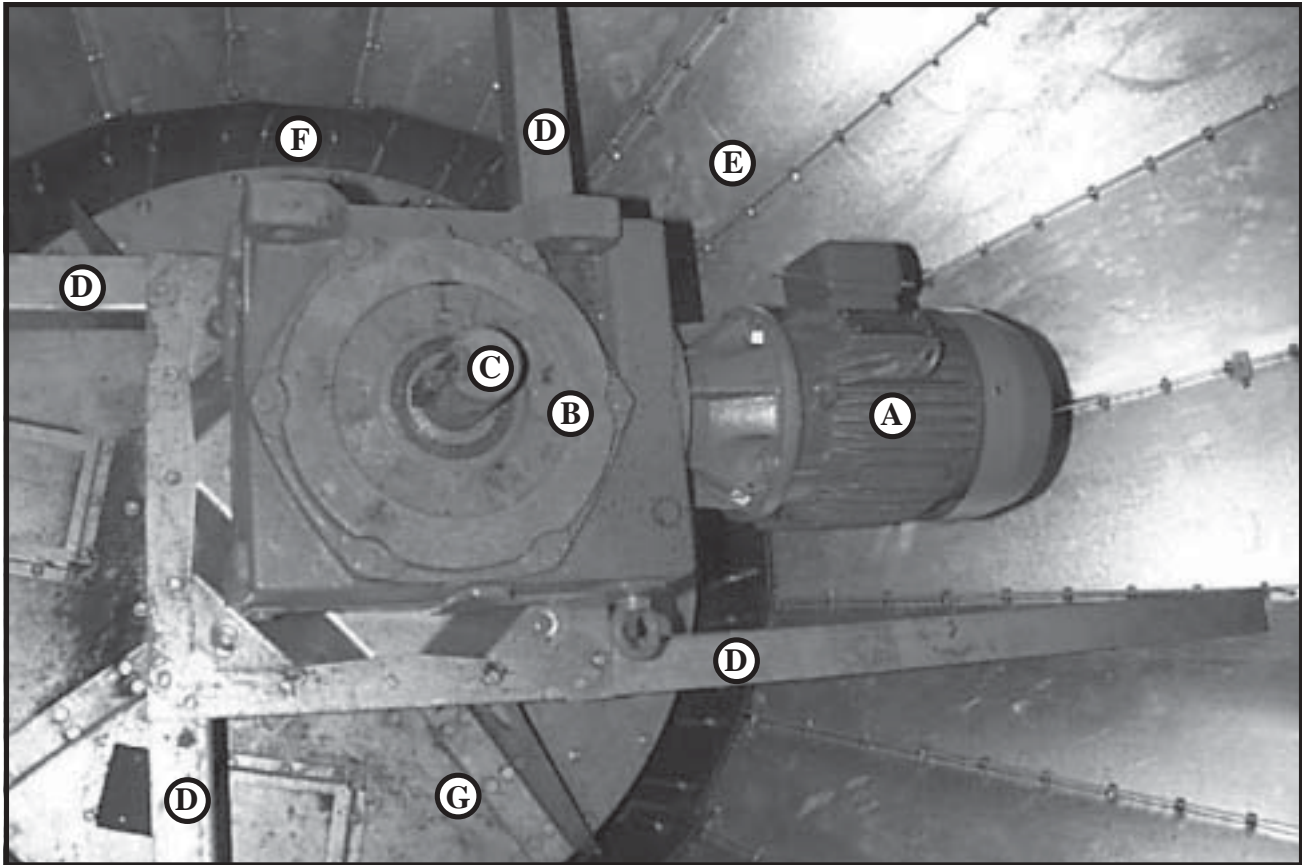

Photo 20-37 Metering System installed (side mount).

- (A) Metering Drum Motor
- (B) Metering Drum Gearbox
- (C) Metering Drum Drive Shaft
- (D) Gearbox Torque Arm Assembly (with 4 arms)
- (E) Inside Hopper Wall
- (F) Metering Drum Baffles
- (G) Metering Drum

**Important Safety Precautions:**

Dryer has sharp edges. These sharp edges may cause serious injury. Use appropriate Personal Protective Equipment. Use proper lifting techniques.



See Chapter 1 “Orientation” for dryer dimensions, components, wall sheet guidelines, etc. See Appendices for “Tools and Equipment”, “Hardware”, etc.

21. Fuel Piping (main)

(Natural Gas or Liquid Propane)

21.1. Piping Through Housing

Attach 12” Nipple and Union to Burner Manifold. Run first 3” pipe section vertically down through Reducer Housing and out pre-cut hole in center of Fan Housing Splice. Secure with Pipe Riser Clamp.

21.2. Piping in Cool Section

Continue 3” Fuel Piping vertically into Cool Section of Dryer to just below bottom of Fans. Add 90 degree Elbow and continue piping horizontally through Dryer Window. Secure Fuel Piping with Clevis Hanger and Threaded Rod as needed.

21.3. Piping Through Window

Run 3” Fuel Piping out Dryer Window and add Elbow.

21.4. Piping Outside Dryer

Continue 3” Fuel Piping from Dryer Window vertically down, parallel to side of dryer. Secure to Compression Angle with U-Bolt. Add Union and 12” Nipple before attaching Fuel Train.



See Chapter 22, “Fuel Train”.

Fuel Piping Runs From Bottom of Burner to Fuel Train on Foundation.

(Main) Fuel Piping and Pilot Fuel Piping usually run parallel.

Electricians will install Pilot Fuel Piping. Pilot Fuel Piping (3/8” copper tubing) runs from Pilot Section on Burner to Pilot Section on Fuel Train.

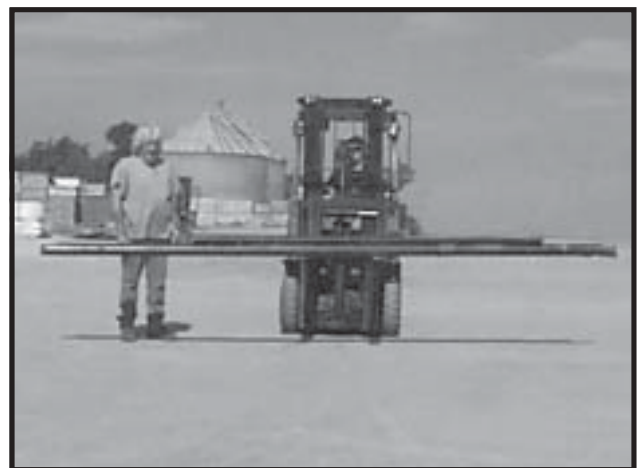

Photo 21-1 3” Fuel Piping.

Fittings for Fuel Piping.



Photo 21-2 Elbow,
3" 90 Degree.



Photo 21-3 3" Union, (3 parts).



Photo 21-4 Nipple,
3" Close.



Photo 21-5 3" U-Bolt.

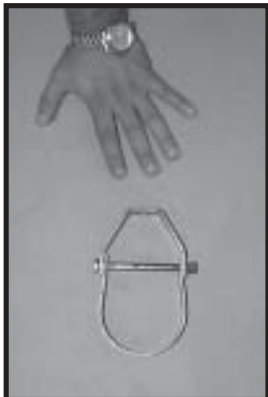

Photo 21-6 Hanger,
3" Clevis.

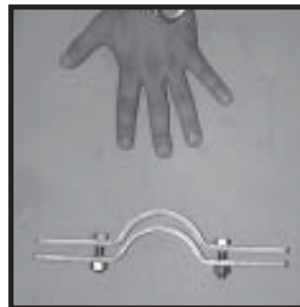

Photo 21-7 3" Pipe Riser Clamp.



Photo 21-8 Threaded Rod.
(Use with 3" Clevis Hanger.)

Chart 21-1 “Fuel Pipe Lengths”*

Dryer Model	Pipe Dia	Outside	Entry	Inside
2500	3"	140"	110"	167"
3000	3"	180"	110"	167"
3500	3"	180"	110"	185"
4000	3"	125" & 94"	110"	185"

* All Piping and fittings are Schedule 40 Black.

Fuel Piping Guidelines



- Fuel Piping can be installed in sections as Dryer is erected, or after Dryer is complete. Usually top two sections of Fuel Piping are installed after Fans are installed.
- Fuel Piping enters Dryer through a Dryer Window. Plan Fuel Piping so it will terminate as near as possible to where Fuel Train will be on Foundation.
- 
 • Seal all threaded pipe connections with Heavy Duty Pipe Sealing Compound. Fuel Piping must be airtight and satisfy any hazard requirement for the site.
- 
 • Check all Fuel Piping is level or plumb.
- 
 • Check all Fuel Piping is secured tightly to Dryer.



Photo 21-9 Seal all threaded pipe connections with Heavy Duty Pipe Sealing Compound.



Photo 21-11 Installed Fuel Pipe exits Heat Section through pre-cut hole in center of Fan Housing Splice (arrow).

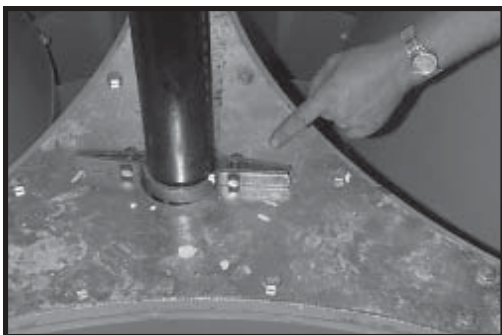

Photo 21-12 Close Up - Installed Fuel Piping exits Heat Section through pre-cut hole in center of Fan Housing Splice. Note 3" Pipe Riser Clamp.

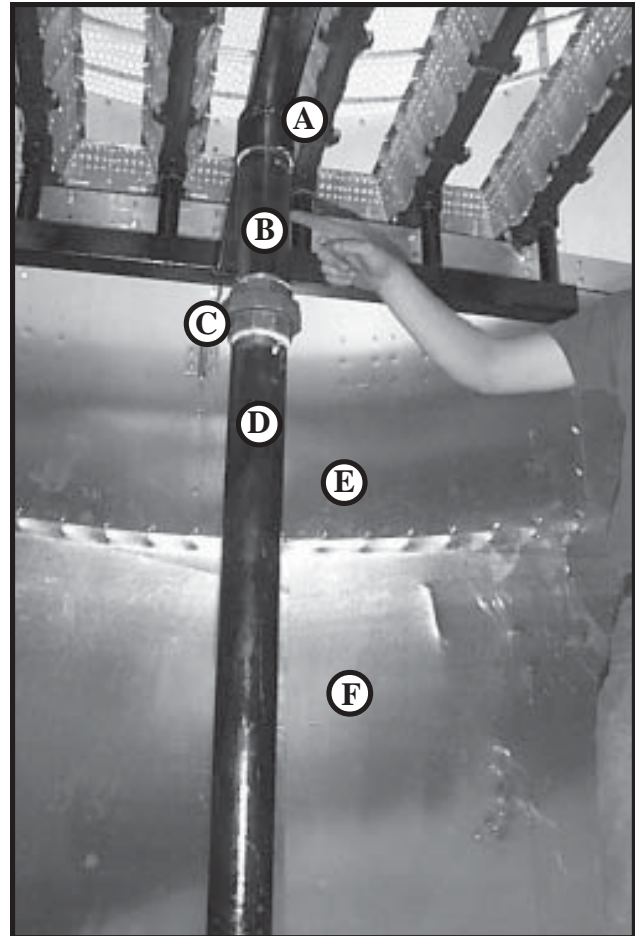

Photo 21-10 Fuel Piping installed to Burner Manifold.

- (A) Burner Manifold
- (B) 3" x 12" Nipple
- (C) 3" Union
- (D) 3" Pipe
- (E) Burner Housing
- (F) Reducer Housing

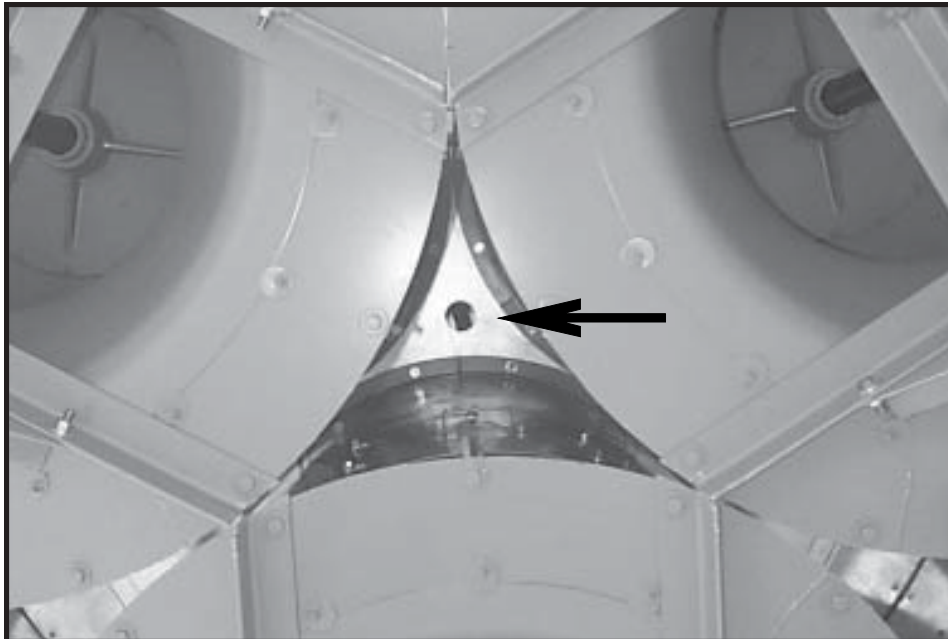

Photo 21-13 Fuel Pipe enters Cool Section through pre-cut hole in center of Fan Housing Splice (arrow).



Photo 21-14 Just below Fans, installed Fuel Piping turns 90 degrees, and exits Cool Section through Dryer Window.



Photo 21-15



Photo 21-17

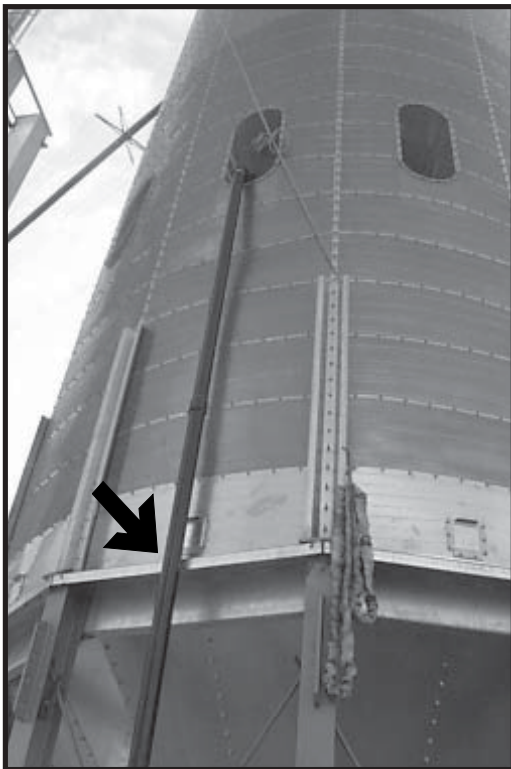
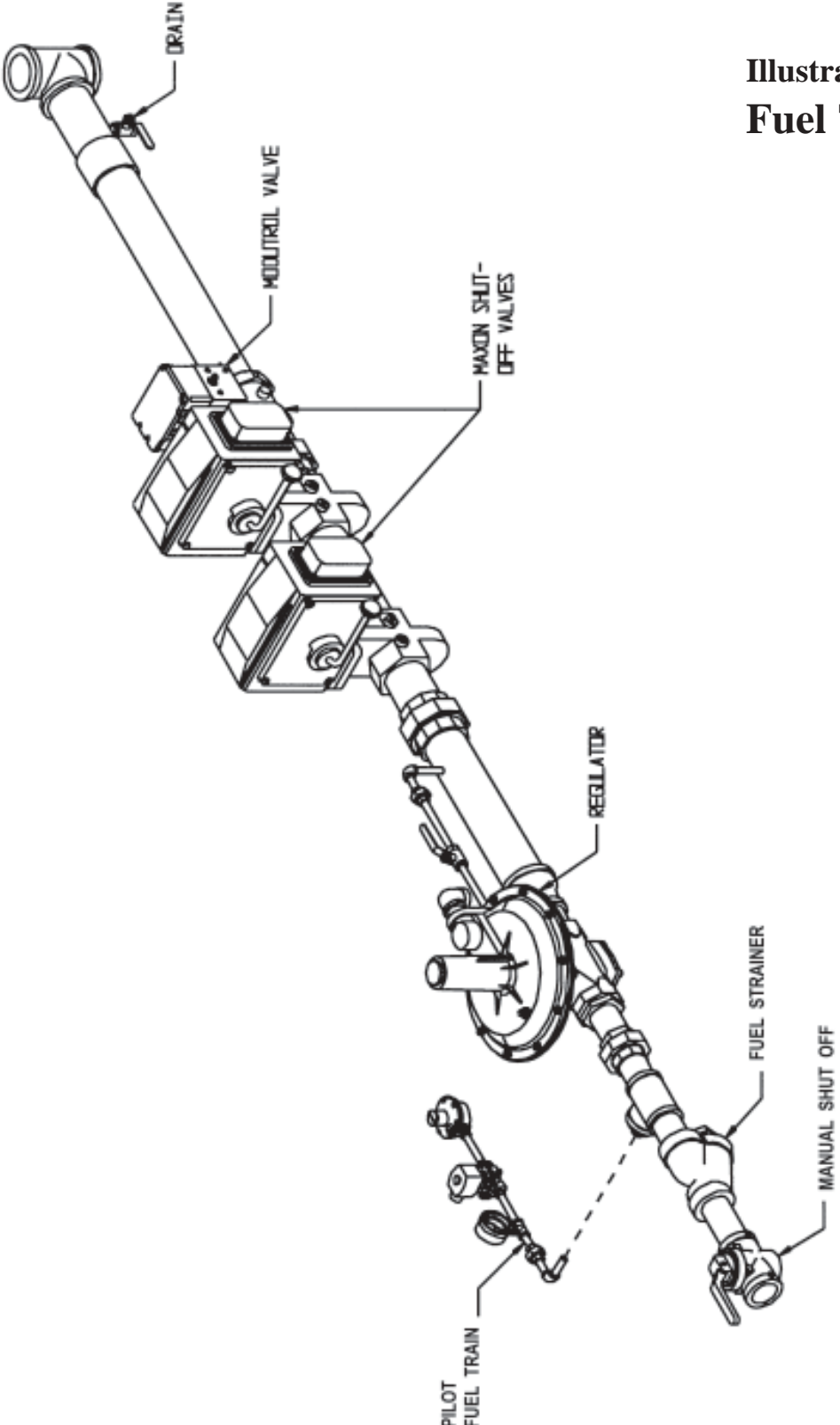

Photo 21-16 Secure piping to Compression Angle with U-Bolt (arrow).

Fuel Train 22

Illustration 22-1
Fuel Train



**Important Safety Precautions:**

Dryer has sharp edges. These sharp edges may cause serious injury. Use appropriate Personal Protective Equipment. Use proper lifting techniques.



See Chapter 1 “Orientation” for dryer dimensions, components, wall sheet guidelines, etc. See Appendices for “Tools and Equipment”, “Hardware”, etc.

22. Fuel Train

(Natural Gas or Liquid Propane)

Pilot Fuel Line	A
Pilot Regulator on Pilot Fuel Train	B
Pilot Solenoid on Pilot Fuel Train	C
Maxon Fuel Shut Off Valve - primary	D
Maxon Fuel Shut Off Valve - secondary	E
Modutrol Motor	F
Main Fuel Regulator	G



Electrical wiring and Pilot Fuel Line installation are done by electricians.

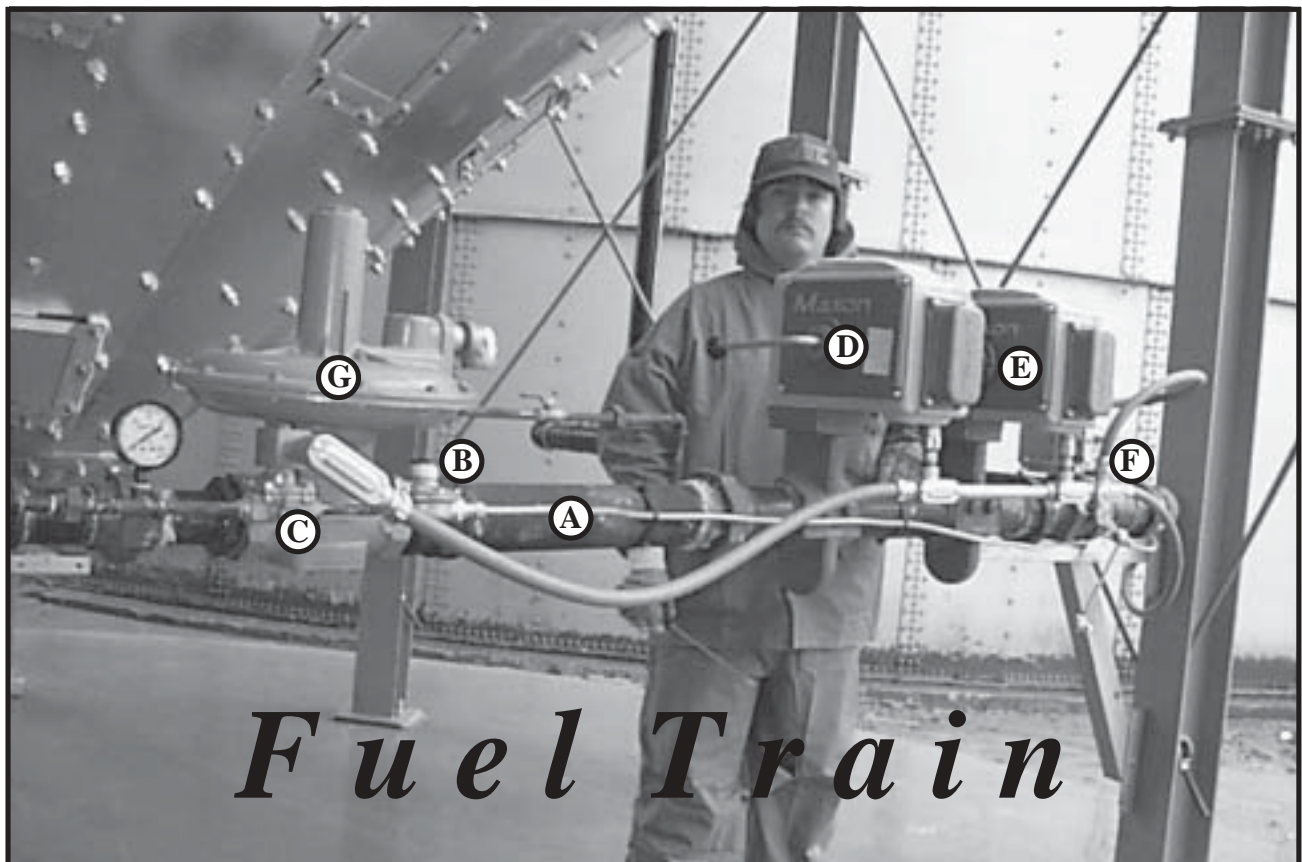

Photo 22-1 Example - Fuel Train installed.

Fuel Train Components (shipped pre-assembled).

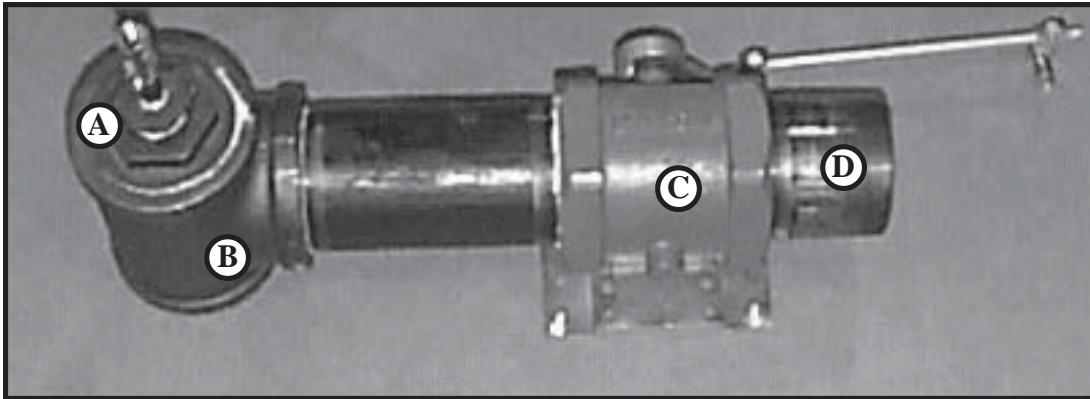

Photo 22-2 3" Modulator Section
 (A) 1/4" shutoff valve
 (B) 3" tee
 (C) 3" modutrol valve
 (D) Linkage

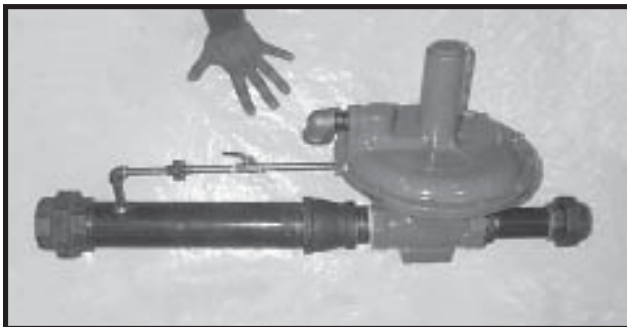

Photo 22-3 3" Regulator Section.

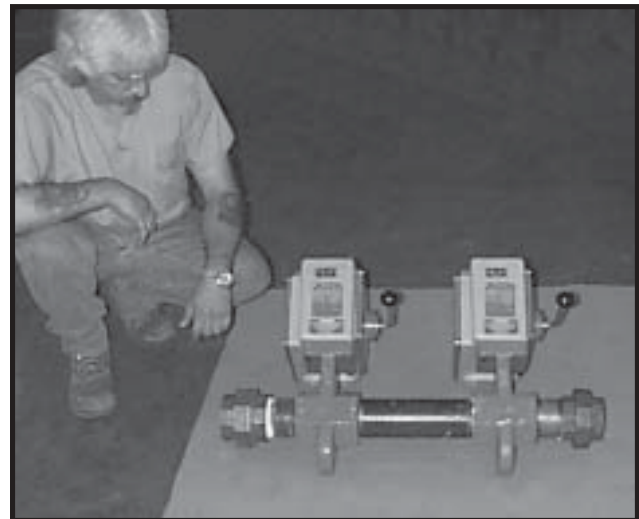

Photo 22-4 3" Maxon Shut Off Valve Section.

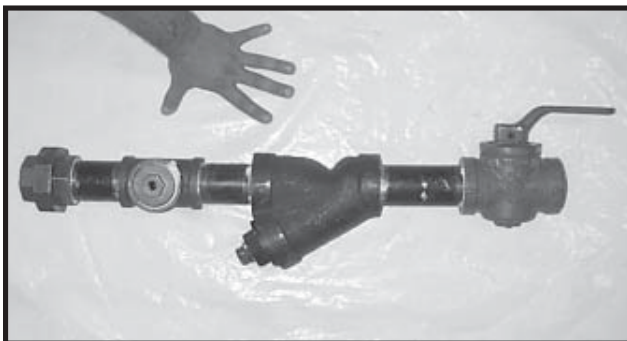

Photo 22-5 2" Manual Shut Off Section.

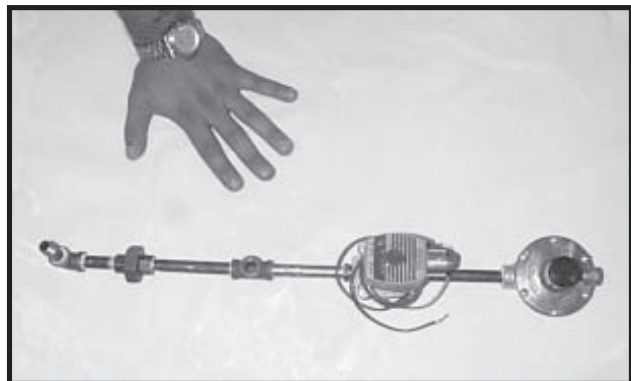

Photo 22-6 1/4" Pilot Section.

Fuel Train - demonstration Close-Ups

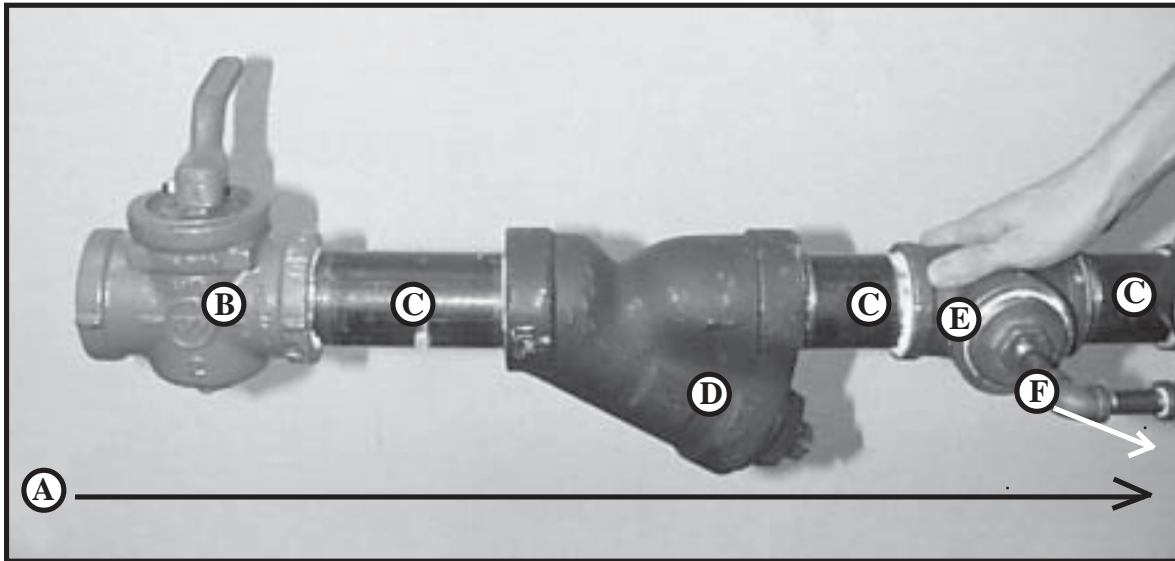

Photo 22-7 A. Main Fuel Train
 B. Manual Shut Off (fuel train intake)
 C. nipple
 D. Strainer with clean-out
 E. tee
 F. Pilot Fuel Train

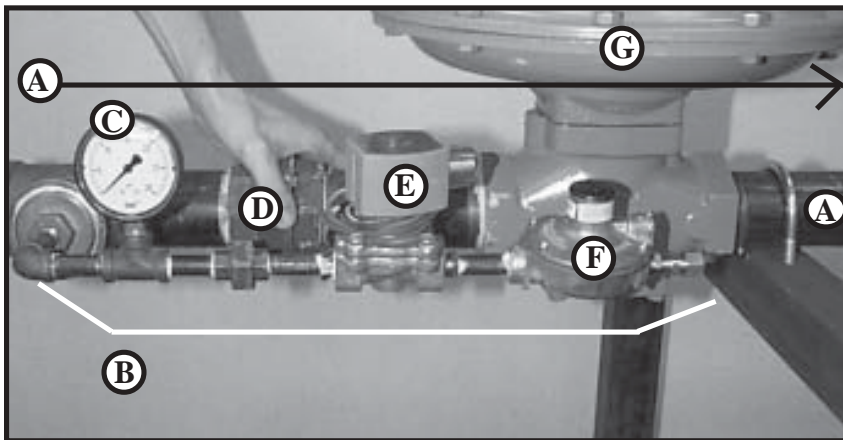

Photo 22-8 A. Main Fuel Train
 B. Pilot Fuel Train
 C. Main Pressure Gauge, 30 pound (oil filled)
 D. union
 E. Pilot Solenoid
 F. Pilot Regulator
 G. Main Regulator

Fuel Train - demonstration Close-Ups continued

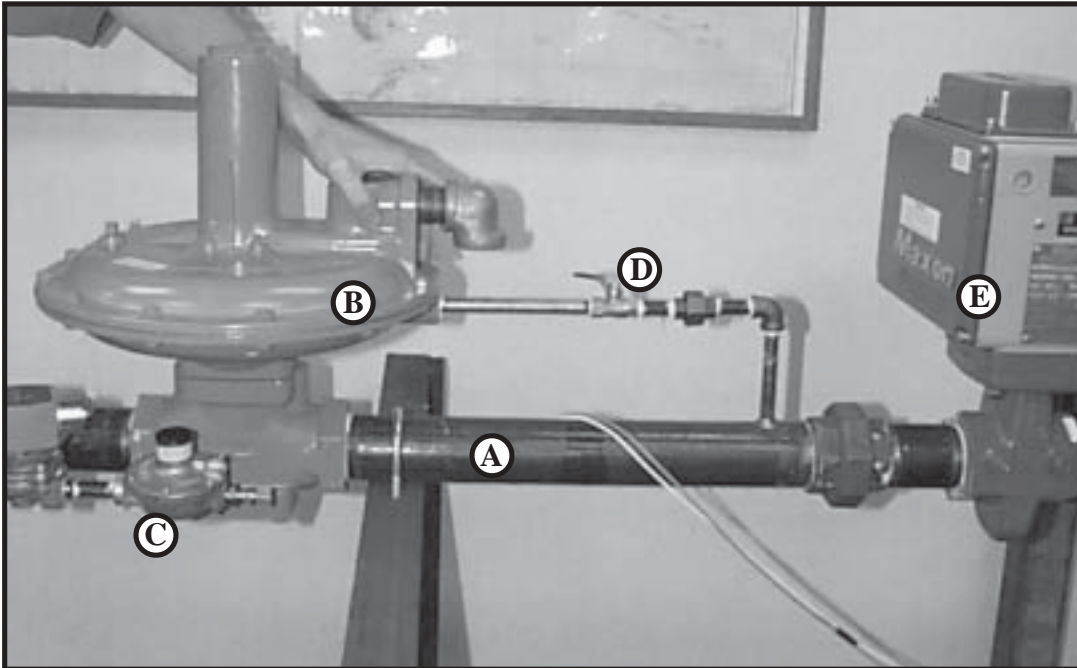

Photo 22-9 A. Main Fuel Train
 B. Main Regulator
 C. Solenoid Regulator on Pilot Fuel Train
 D. Regulator Feedback Line Control Valve
 E. Maxon

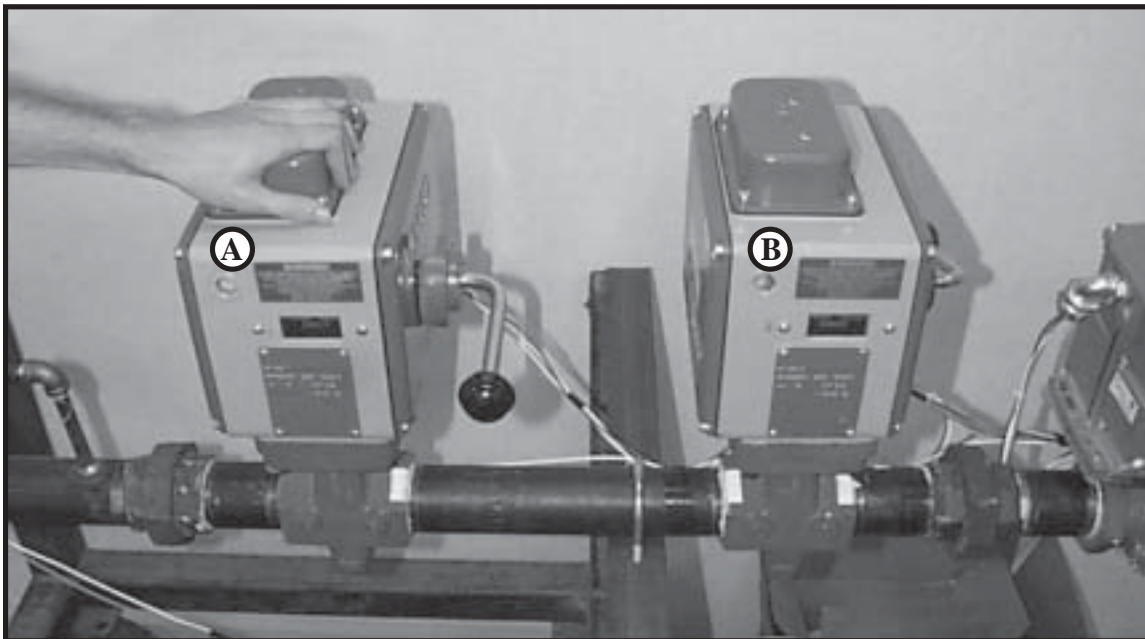

Photo 22-10 A. Primary Maxon Shut Off Valve (closest to fuel intake)
 B. Secondary Maxon Shut Off Valve (downstream from primary maxon)

Fuel Train - demonstration Close-Ups *continued*

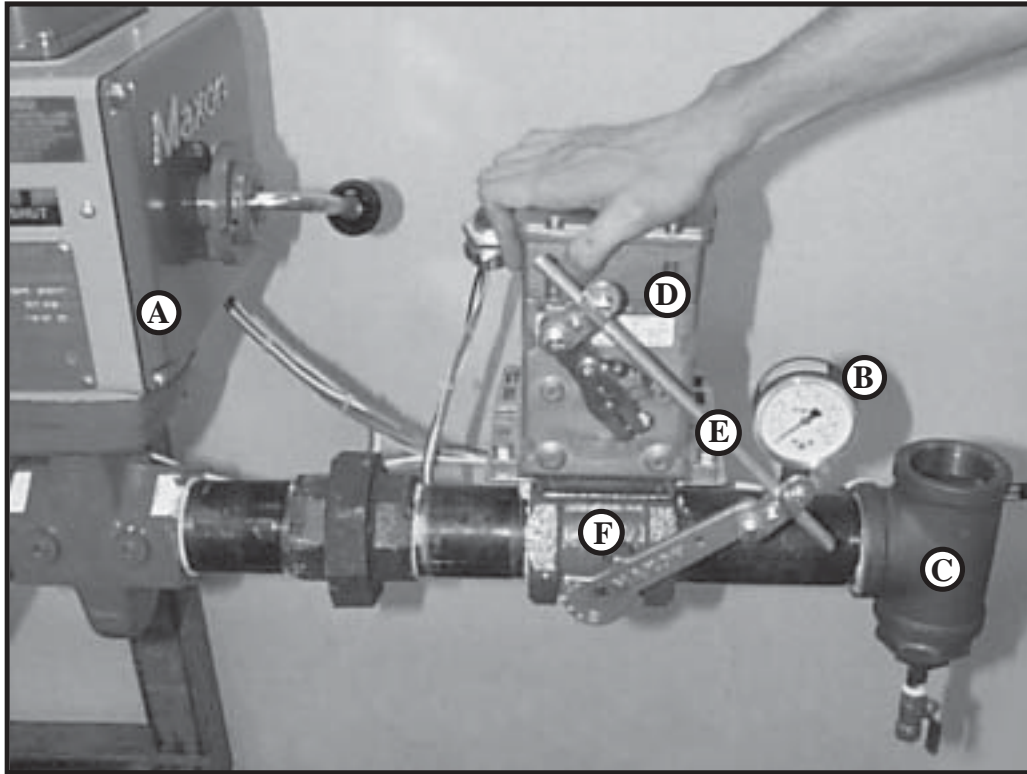

Photo 22-11

- A. Secondary Maxon Shut Off Valve*
- B. Ounce Gauge*
- C. Tee (up to dryer) (down to drain valve)*
- D. Modutrol Motor*
- E. Flow Control Valve Linkage*
- F. Maxon Flow Control (butterfly) Valve*

Fuel Train

Installation Guidelines

- Fuel Train components will be wired to Electrical Control System (by electricians), so locate Fuel Train as close as possible to Electrical Control System.
- Mount Fuel Train on two or three stands as required. Mark, cut, and drill to adapt Fuel Train stands to meet specific site requirements.
- Check during installation to keep Fuel Train level.
- As required, break apart Fuel Train components, and install as shown in Illustration 22-1, “Fuel Train”.
- !
 Seal all threaded pipe connections with Heavy Duty Pipe Sealing Compound.
- Check arrows (or other fuel intake direction indicators) on all Fuel Train components. Be sure all arrows point in direction of fuel flow.
- !
 • Until Fuel Train installation on stands is complete, support components securely at all times.

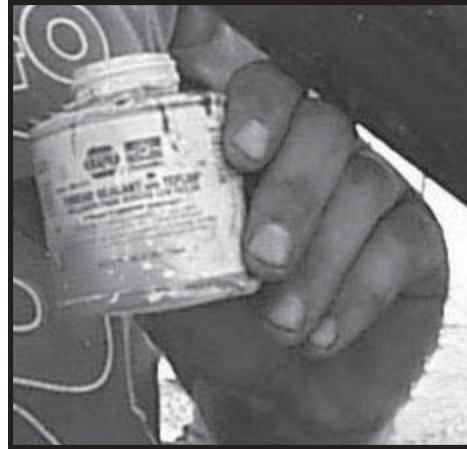

Photo 22-12 Seal all threaded pipe connections with Heavy Duty Pipe Sealing Compound.



Photo 22-13 As required, break apart Fuel Train components, and install as shown in Illustration 22-1, “Fuel Train”.



Photo 22-14



Photo 22-15 Attaching Union to Fuel Pipe.



Photo 22-16 Attaching 12" Nipple to Modutrol Section.



Photo 22-17 Connecting Modutrol Section to Fuel Pipe.

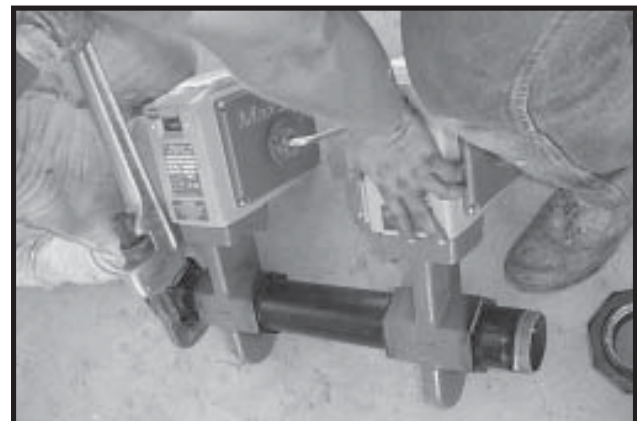

Photo 22-18 Maxon Section.

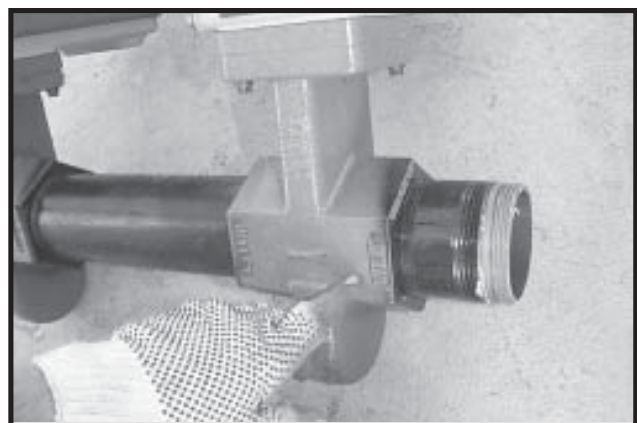

Photo 22-19 Close up - Maxon.
Note fuel flow indicators on all components.

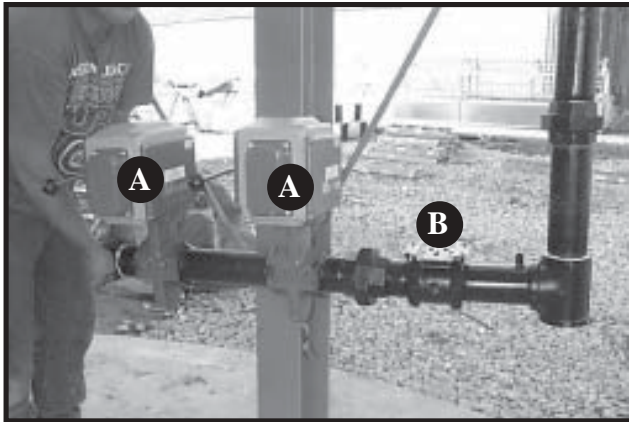

Photo 22-20 Maxons (A) and Modutrol Mounting Bracket (B) installed. Support Fuel Train at all times.



Photo 22-21 Installing Regulator Section.



Photo 22-22 Checking Fuel Train is level, then measuring for Fuel Train stands.

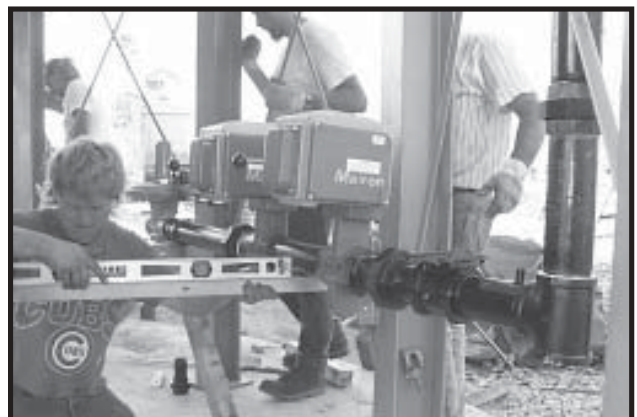

Photo 22-23 Adapt Fuel Train Stands to meet site requirements.



Photo 22-24 Close up - Bolting Fuel Train Stand.



Photo 22-25 Securing Fuel Train to Fuel Train stand with 3" U-Bolt.



Photo 22-26 Installing Shutoff Section.



Photo 22-27 Second Fuel Train stand installed.

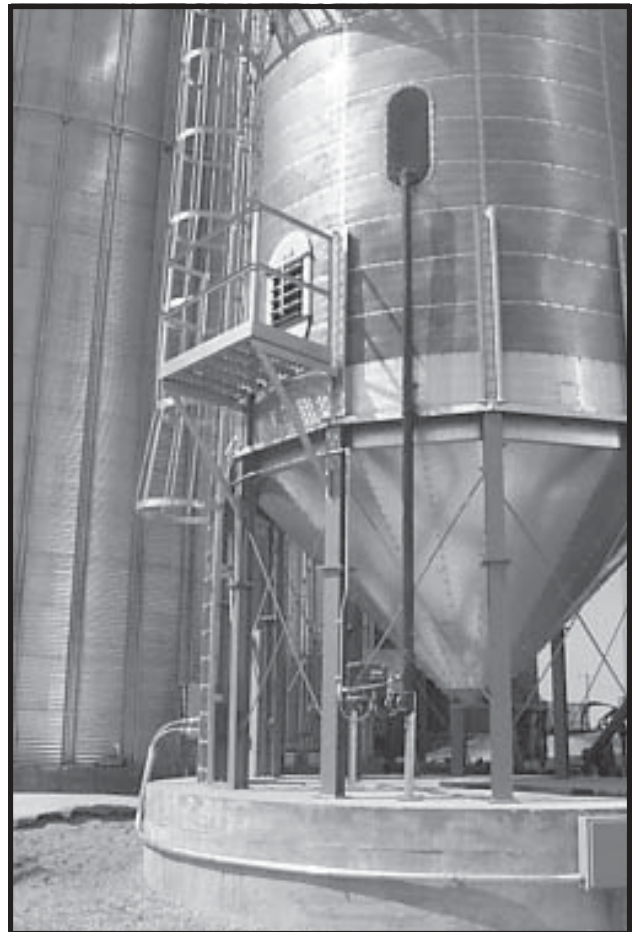

Photo 22-28 Fuel Train installed. (Typical)



Important Safety Precautions:
Dryer has sharp edges. These sharp edges may cause serious injury. Use appropriate Personal Protective Equipment. Use proper lifting techniques.



See Appendices for “Recommended Tools and Equipment List”, “Hardware”, etc.

23. Electrical Control System

The **Electrical Control System** consists of a main **Power Box** and a **Control Box**. The Control Box is usually attached and wired to the Power Box at the factory. (Photo 23-1)

See “Electrical Installation Manual” for steps to install Electrical Control System.

Until Electrical Control System is installed, place it on Dryer Foundation and secure it to Dryer Leg.

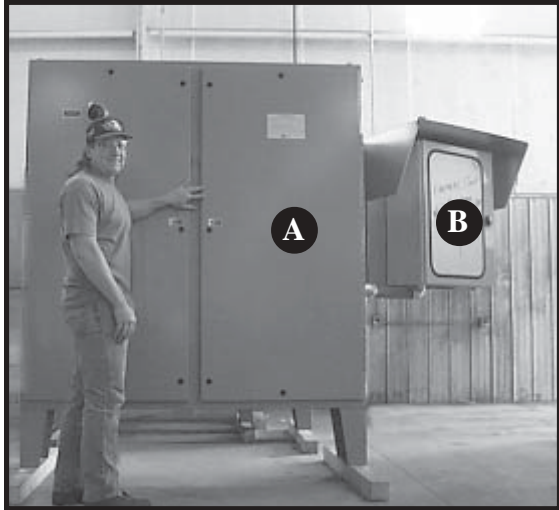

Photo 23-1
(A) Power Box
(B) Control Box
with Electronic Monitoring Control System



Photo 23-2 Electrical Control System.

THE GSI GROUP, INC. ("GSI") WARRANTS ALL PRODUCTS MANUFACTURED BY GSI TO BE FREE OF DEFECTS IN MATERIAL AND WORKMANSHIP UNDER NORMAL USAGE AND CONDITIONS FOR A PERIOD OF 24 MONTHS AFTER RETAIL SALE TO THE ORIGINAL END USER OF SUCH PRODUCTS. GSI'S ONLY OBLIGATION IS, AND PURCHASER'S SOLE REMEDY SHALL BE FOR GSI, TO REPAIR OR REPLACE, AT GSI'S OPTION AND EXPENSE, PRODUCTS THAT, IN GSI'S SOLE JUDGMENT, CONTAIN A MATERIAL DEFECT DUE TO MATERIALS OR WORKMANSHIP. ALL DELIVERY AND SHIPMENT CHARGES TO AND FROM GSI'S FACTORY WILL BE PURCHASER'S RESPONSIBILITY. EXPENSES INCURRED BY OR ON BEHALF OF THE PURCHASER WITHOUT PRIOR WRITTEN AUTHORIZATION FROM AN AUTHORIZED EMPLOYEE OF GSI SHALL BE THE SOLE RESPONSIBILITY OF THE PURCHASER.

EXCEPT FOR THE ABOVE STATED EXPRESS LIMITED WARRANTIES, GSI MAKES NO WARRANTY OF ANY KIND, EXPRESSED OR IMPLIED, INCLUDING, WITHOUT LIMITATION, WARRANTIES OF MERCHANTABILITY OR FITNESS FOR A PARTICULAR PURPOSE OR USE IN CONNECTION WITH (i) PRODUCT MANUFACTURED OR SOLD BY GSI OR (ii) ANY ADVICE, INSTRUCTION, RECOMMENDATION OR SUGGESTION PROVIDED BY AN AGENT, REPRESENTATIVE OR EMPLOYEE OF GSI REGARDING OR RELATED TO THE CONFIGURATION, INSTALLATION, LAYOUT, SUITABILITY FOR A PARTICULAR PURPOSE, OR DESIGN OF SUCH PRODUCT OR PRODUCTS.

IN NO EVENT SHALL GSI BE LIABLE FOR ANY DIRECT, INDIRECT, INCIDENTAL OR CONSEQUENTIAL DAMAGES, INCLUDING, WITHOUT LIMITATION, LOSS OF ANTICIPATED PROFITS OR BENEFITS. PURCHASER'S SOLE AND EXCLUSIVE REMEDY SHALL BE LIMITED TO THAT STATED ABOVE, WHICH SHALL NOT EXCEED THE AMOUNT PAID FOR THE PRODUCT PURCHASED. THIS WARRANTY IS NOT TRANSFERABLE AND APPLIES ONLY TO THE ORIGINAL PURCHASER. GSI SHALL HAVE NO OBLIGATION OR RESPONSIBILITY FOR ANY REPRESENTATIVE OR WARRANTIES MADE BY OR ON BEHALF OF ANY DEALER, AGENT OR DISTRIBUTOR OF GSI.

GSI ASSUMES NO RESPONSIBILITY FOR FIELD MODIFICATIONS OR ERECTION DEFECTS WHICH CREATE STRUCTURAL OR STORAGE QUALITY PROBLEMS. MODIFICATIONS TO THE PRODUCT NOT SPECIFICALLY COVERED BY THE CONTENTS OF THIS MANUAL WILL NULLIFY ANY PRODUCT WARRANTY THAT MIGHT HAVE BEEN OTHERWISE AVAILABLE.

THE FOREGOING WARRANTY SHALL NOT COVER PRODUCTS OR PARTS WHICH HAVE BEEN DAMAGED BY NEGLIGENT USE, MISUSE, ALTERATION OR ACCIDENT. THIS WARRANTY COVERS ONLY PRODUCTS MANUFACTURED BY GSI. THIS WARRANTY IS EXCLUSIVE AND IN LIEU OF ALL OTHER WARRANTIES EXPRESS OR IMPLIED. GSI RESERVES THE RIGHT TO MAKE DESIGN OR SPECIFICATION CHANGES AT ANY TIME.

PRIOR TO INSTALLATION, PURCHASER HAS THE RESPONSIBILITY TO RESEARCH AND COMPLY WITH ALL FEDERAL, STATE AND LOCAL CODES WHICH MAY APPLY TO THE LOCATION AND INSTALLATION.



TOOLS and EQUIPMENT



Important Safety Precautions: Dryer Parts have sharp edges.
Use Appropriate Personal Protective Equipment.
Use proper lifting technique.

- (8) jacks (10,000 pound, 14' lift), and lifting tackel
- forklift(s), hoist, or tractor
with 2"x14' nylon lifting straps, rating 2000 pounds
(optional to place electrical control system)
- Dollies (with 5/8" x 2" heavy structural bolts to secure load)
- 3/8" and 1/2" drive impact wrench or rachet, with sockets
- drill: 1/2", 3/8" bits, and assorted drill bits
hammer drill: 1/2" masonry bits
7/8" masonry bit
- wrenches: 1/2", 7/16", 9/16", 5/8", 11/16", 3/4", 15/16"
hex wrenches (allen wrenches): 1/8", 5/32", 3/16", 3/8"
- tongue and groove pliers, locking pliers (vise grips)
- banding cutters or equivalent equipment
- reciprocating saw or hacksaw
- 3/8" x 12" and larger alignment punches, C-clamps
- electrical extension cords, 12 gauge heavy duty, weather-tight
- hammers, 10 pound, 2 pound, 13 ounce ball-peen
- stepladders (4', 8'), extension ladder
- 12" level, level-transom, tape measure
- heavy-duty pipe sealing compound
- marking pen (for steel, concrete)
- injection silicone caulking, clean-out brush, and air bulb
- WD40 machine weight lubricating oil
- touch-up paint



TOOLS and EQUIPMENT continued



Photo A-1 C-clamp and assorted alignment punches.



Photo A-2 Metal Shear to cut Wall Sheets and screen.

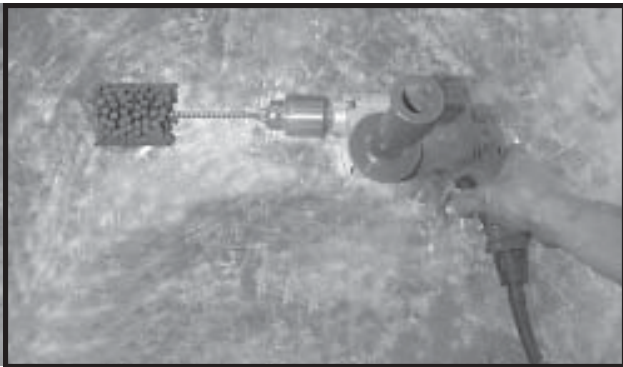

Photo A-3 Drill with Ball-Hone to clean out Gearbox bore.

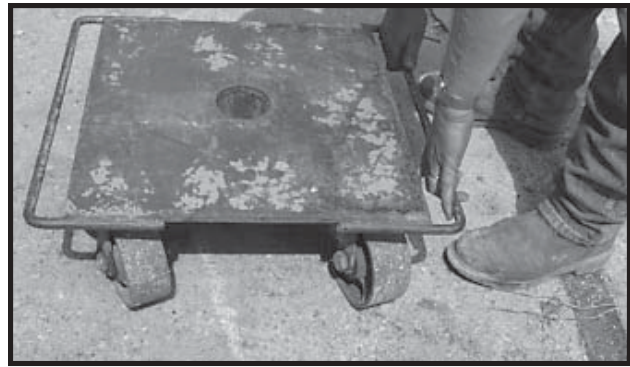

Photo A-4 Dolly is a low, flat, wheeled frame used to move heavy parts, for example, fans.



Photo A-5 Level-Transom.

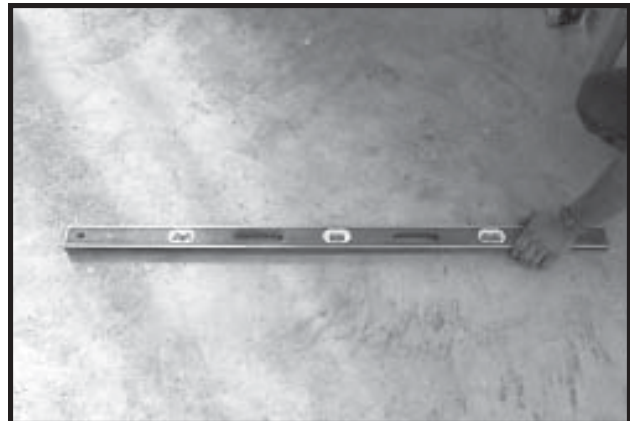

Photo A-6 Level.



HARDWARE

Quantity of hardware varies by dryer model.

DESCRIPTION **USES**

GALVANIZED

5/16" x 3/4" Slotted Truss Head Bolt	Cool Room Floor
5/16" X 3/4" Whiz Lock Bolt	Inside Wall Sheets
5/16" X 1" Whiz Lock Bolt	Inside Wall Sheets
5/16" Whiz Lock Nut	Inside Wall Sheets
#10 x 1" Self Tapping Screw	Heat Section Door & Cool Room Floor
3/8" Washer	Walkways
3/8" Hex Head Nut	Walkways
3/8 x 1" Hex Head Bolt	Walkways
3/8" x 2" Hex Head Bolt	Lifting Clips to Vertical Channels & Base Stiffeners to Vertical Channels
1/2" x 1" Hex Head Bolt	Outside Hopper Sheets & Gearbox Motor to Gearbox
1/2" Hex Head Nut	Outside Hopper Sheets
1/2" Washer	Outside Hopper Sheets
1/2" x 1-1/2" grade 8, Hex Head Bolt	Blower Bracing
1/2" x 2"-1/2" grade 5, Hex Head Bolt	Base Stiffeners
5/8" x 1-1/2" grade 8, Hex Head Bolt	Legs
5/8" x 2-3/4" grade 8, Hex Head Bolt	Base Stiffeners to Legs
5/8" x 2" grade 8, Hex Head Bolt	Leg to Leg
5/8", grade 5-1, Hex Head Nut	Leg to Leg
3/4" Washer (1-1/2" diameter)	Legs
3/4" Hex Head Nut	X-Rods
3/4" Washer (2" diameter)	X-Rods

STAINLESS STEEL

5/16" x 3/4" Whiz Lock Bolt	Outside Wall Sheets
5/16" x 1" Whiz Lock Bolt	Outside Wall Sheets
5/16" Whiz Lock Nut	Outside Wall Sheets

MISCELLANEOUS

Anchor Bolt, HILTI HAS, 3/4" x 9-5/8"	Legs
Anchor Bolt, Heavy Duty Expanding, 1/2" x 3-3/4"	Control Box
De Sta Co Clamp	Hopper Access Port



Hardware continued

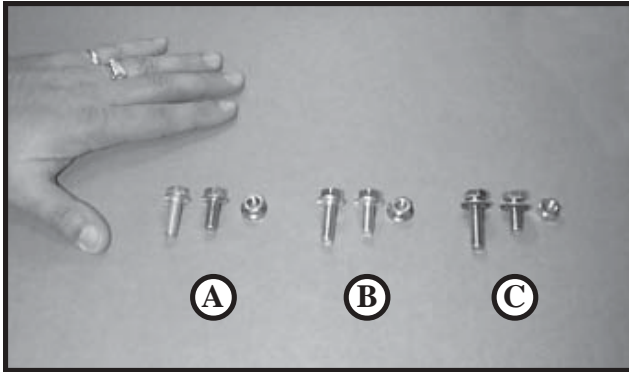

Photo B-1 Comparison of 5/16" hardware.



Photo B-2 Anchor Bolt, HILTI HAS, 3/4" x 9-5/8".

(A) Stainless, Whiz Lock

- Bolts = dull silver
- Nuts = shiny silver (with flange)

(B) Galvanized, Whiz Lock

- Bolts = shiny silver
- Nuts = yellow (with flange)

(C) Bin, Hex Head

- Bolts = yellow (with neoprene washers)
- Nuts = yellow (no flange)

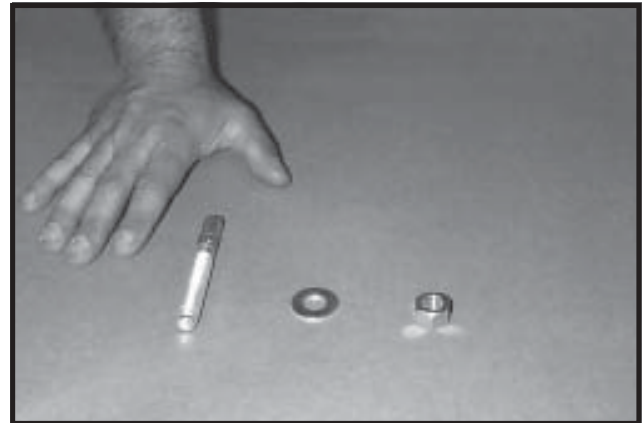

Photo B-3 Anchor Bolt, Heavy Duty Expanding, 5-1/2".

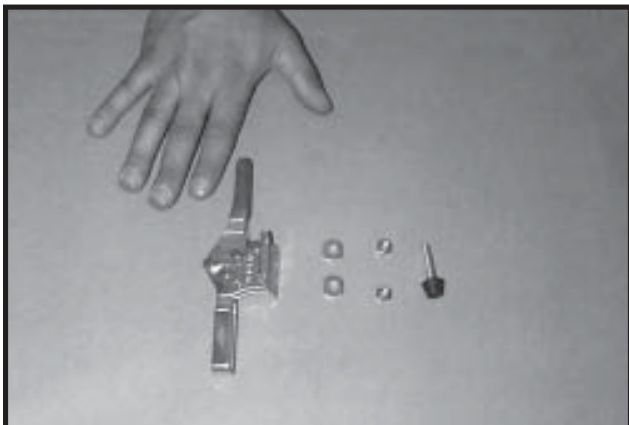

Photo B-4 De Sta Co Clamp.

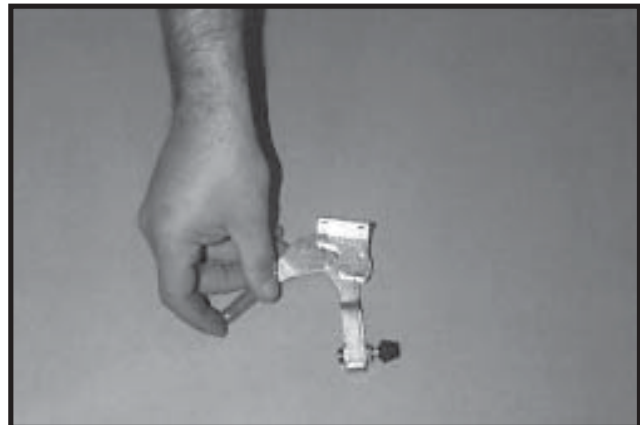

Photo B-5 De Sta Co Clamp - assembled.



HARDWARE - GALVANIZED

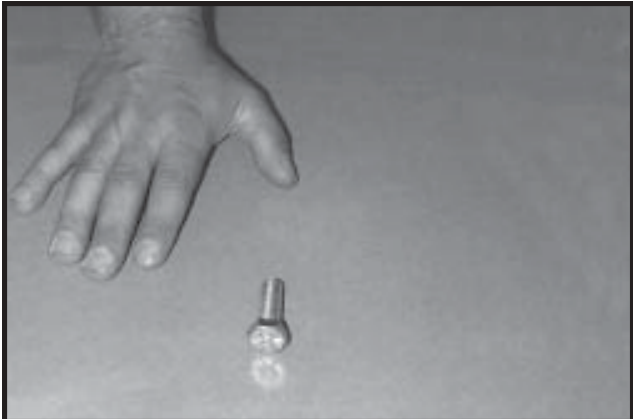

Photo B-6 1/2" x 1-1/2" grade 8 Hex Head Bolt.

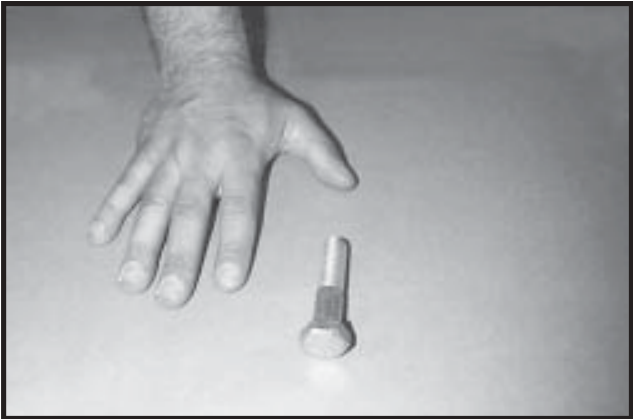

Photo B-7 1/2" x 2-1/2" Hex Head Bolt.

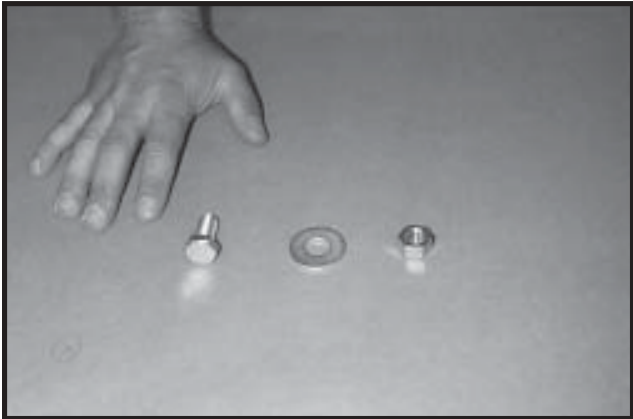

Photo B-8 1/2" x 1" Hex Head Bolt, washer & nut.

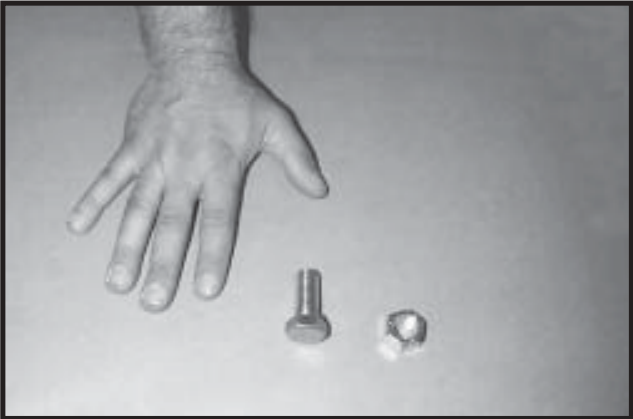

Photo B-9 5/8" x 1-1/2" grade 8 Hex Head Bolt.



Photo B-10 5/8" x 2-3/4" Hex Head Bolt.

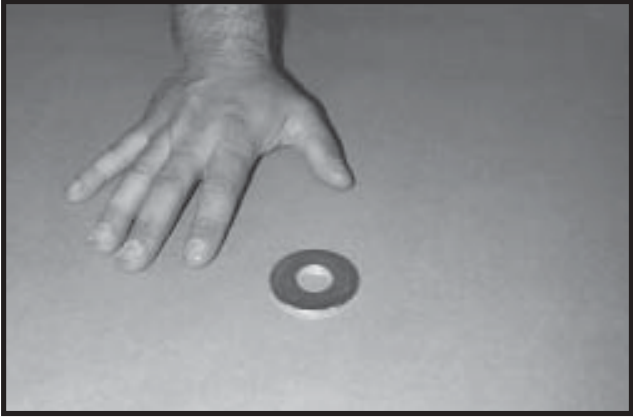

Photo B-11 3/4" (2" diameter) washer.



HARDWARE - GALVANIZED continued



Photo B-12 3/8" x 1" Hex Head Bolt.



Photo B-13 5/16" x 3/4" Slotted Truss Head Bolt.



Photo B-14 3/8" x 2 Bolt, washer & nut.



Photo B-15 #10 x 1" Self Tapping Screw

ASSEMBLY TERMS

TERMS	MEANING
assembly of parts	parts are fit together, and often bolted.
bindicator(s) [®]	<u>Lower Bindicator</u> is installed high on the side of all dryers. It indicates low grain level in garner section, and automatically starts flow of grain to dryer. <u>Upper Bindicator</u> is only installed on slide gate or conveyor fill dryers (on roof). It indicates when garner section is full, and automatically stops flow of grain to dryer.
bolt	tightly bolt for final assembly unless otherwise indicated. loosely bolt bolt loosely to allow easy addition of parts later. snug bolt tighten bolt snug with fingers to hold in place. common bolt insert bolt through all parts to be held together. existing bolts..... refers to bolts already installed in dryer.
bph	bushels per hour.
channel.....	metal part whose channel is shaped like a bracket  . Examples: Vertical Channels, Rolled Plenum Channels.
double nut	spin two nuts closely together on bolt. Tighten second nut against first nut to lock.
finer	fine debris from grain. Also called bee's wings. Avoid hazardous accumulation of fines in dryer.
flange	a projecting rim or edge on a part to hold it to another part.
grain columns	The space around dryer through which grain flows from top to bottom. Each grain column is formed by columns of Vertical Channels, Inside Wall Sheets, Outside Wall Sheets.
grain turner	turns dryer-warmed grain from inside grain column to outside of grain column; and turns wetter, cooler grain from outside of grain column to inside of grain column. Grain dries uniformly.

ASSEMBLY TERMS continued

TERMS	MEANING
hoppers	Divider Hopper - divides Heat Section from Cool Section. - funnels fine debris to cooling section.
	Discharge Hopper - located below Cool Section floor. - directs grain to metering drum for discharge.
level	even across, horizontal.
LH	Left Hand.
Lift	raise dryer to clear next set of Vertical Channels.
motor window.....	dryer fan motors conduits enter through the motor window.
overheats	detect air temperature that has exceeded a preset limit.
overlap	lap. Each part extends over previous part, usually bolted together with common bolts.
pipe sealing compound	also called heavy-duty thread sealing compound, or pipe dope.
plenum	hot, dry air chamber above burner in dryer.
plumb	straight down, vertical.
RH	Right Hand.
RTD	Resistance Temperature Device. RTD measures temperature of grain/air.
wall sheets	dryer walls (inside and outside) are build with rings of Wall Sheets. Also called screens. Sizes are .063 perforated sheet and .078 perforated sheet.

U.S. TO METRIC CONVERSION TABLES

Inch Conversion Table

Refer to the conversion tables in Appendix E for conversions from U.S. measures to metric measurements.

To assemble this grain dryer, you may need standard U.S. dimension tools. However, some metric tools will fit on U.S. dimension hardware.

Fractions	Decimals	Millimeters	Fractions	Decimals	Millimeters
1/64	.0156	.3969	33/64	.5156	13.0969
1/32	.0313	.07938	17/32	.5313	13.4938
3/64	.0469	1.1906	35/64	.5469	13.8906
1/16	.0625	1.5875	9/16	.5625	14.2875
5/64	.0781	1.9844	37/64	.5781	14.6844
3/32	.0938	2.3813	19/32	.5938	15.0813
7/64	.1094	2.7781	39/64	.6094	15.4781
1/8	.125	3.1750	5/8	.625	15.8750
9/64	.1406	3.5719	41/64	.6406	16.2719
5/32	.1563	3.9688	21/32	.6563	16.6688
11/64	.1719	4.3656	43/64	.6719	17.0656
3/16	1.875	4.7625	11/16	.6875	17.4625
13/64	.2031	5.1594	45/64	.7031	17.8594
7/32	.2188	5.5563	23/32	.7188	18.2563
15/64	.2344	5.9531	47/64	.7344	18.6531
1/4	.250	6.3500	3/4	.750	19.0500
17/64	.2656	6.7469	49/64	.7656	19.4469
9/32	.2813	7.1438	25/32	.7813	19.8438
19/64	.2969	7.5406	51/64	.7969	20.2406
5/16	.3125	7.9375	13/16	.8125	20.6375
21/64	.3281	8.3344	53/64	.8281	21.0344
11/32	.3438	8.7313	27/32	.8438	21.4313
23/64	.3594	9.1281	55/64	.8594	21.8281
3/8	.375	9.5250	7/8	.875	22.2250
25/64	.3906	9.9219	57/64	.8906	22.6219
13/32	.4063	10.3188	29/32	.9063	23.0188
27/64	.4219	10.7156	59/64	.9219	23.4156
7/16	.4375	11.1125	15/16	.9375	23.8125
29/64	.4531	11.5094	61/64	.9531	24.2094
15/32	.4688	11.9063	31/32	.9688	24.6063
31/64	.4844	12.3031	63/64	.9844	25.0031
1/2	.500	12.7000	1	1.000	25.4000

U.S. TO METRIC CONVERSION TABLES

Conversion Factors

Multiply	by	To Obtain
British Thermal Unit (Btu)	2.928×10^{-4}	kilowatt · hr (kWh)
Btu/hr	3.930×10^{-4}	horsepower (hp)
Btu/hr	0.293	watt (W)
horsepower (hp)	745.7	watt (W)
inch (in)	2.540	centimeter (cm)
foot (ft)	0.3048	meter (m)
pound-mass (lbm avdp*)	0.454	kilogram (kg)
pounds per square inch (psi)	6,895	Pascal (Pa)
bushels (bu)	0.03524	cubic meter (m ³)
°F (Fahrenheit)	$(F - 32) / 1.8$	°C (Celsius)
°C (Celsius)	$1.8 (C) + 32$	°F (Fahrenheit)

* avdp = avoirdupois

U.S. TO METRIC CONVERSION TABLES

AWG* Wire Gage
(solid conductor wire)

AWG Gage No.	Cross-sectional Area		Diameter of solid wire	Circular
	mm ²	inches ²	mm	mils
32	.0032	0.00005	0.0202	63.2
30	0.0505	0.000079	0.255	100.5
28	0.0806	0.000125	0.321	159.8
26	0.129	0.000199	0.405	254
	0.196	0.000304	0.5	387
24	0.205	0.000317	0.511	404
	0.283	0.00483	0.6	558
20	0.518	0.000802	0.812	1022
	0.75	0.001162	0.977	1480
18	0.821	0.001272	1.022	1620
	1	0.00155	1.128	1973
16	1.307	0.002026	1.29	2580
	1.5	0.002325	1.382	2960
14	2.082	0.003228	1.628	4110
	2.5	0.003875	1.784	4934
12	3.309	0.005129	2.053	6530
	4	0.0062	2.257	7894
10	5.26	0.008152	2.588	10380
	6	0.0093	2.763	11841
8	8.365	0.012967	3.264	16540
	10	0.0155	3.568	19735
6	13.296	0.02061	-	26240
	16	0.0248	-	31576
4	21.15	0.03278	-	41740
	25	0.0388	-	49338
2	33.62	0.0521	-	66360

* American Wire Gage.

Address correspondence to:



a division of

THE GSI GROUP



**1004 East Illinois Street
Post Office Box 20
Assumption, IL 62510-0020
United States of America**



Or call:

U.S. telephone: 217.226.4421

U.S. toll free fax: 1.800.800.5329

international fax: 217.226.3404

e-mail: gsisales@grainsystems.com

internet: <http://www.grainsystems.com>

Refer to:

PNEG-707

Printing Date: March 1999

Please contact Grain Systems with any comments or suggestions for improvement in product or service.

THIS EQUIPMENT SHALL BE INSTALLED IN ACCORDANCE WITH THE CURRENT INSTALLATION CODES AND APPLICABLE REGULATIONS WHICH SHOULD BE CAREFULLY FOLLOWED IN ALL CASES. AUTHORITIES HAVING JURISDICTION SHOULD BE CONSULTED BEFORE INSTALLATIONS ARE MADE.

a division of
THE GSI GROUP



1004 East Illinois Street
Post Office Box 20
Assumption, IL 62510-0020
United States of America
U.S. telephone: 217.226.4421
U.S. toll free fax: 1.800.800.5329
International fax: 217.226.3404
e-mail: gisales@grainsystems.com
internet: <http://www.grainsystems.com>

PNEG-707

W:\PNEG\707-1998.p65

Printed: March 1999