



12', 18', 24' and 30' GSI Commercial Tower Dryer

Construction Manual

PNEG-707

Date: **09-29-20**

GSI GROUP



PNEG-707

Contents

Chapter 1 Introduction	6
Chapter 2 Safety	7
Safety Guidelines	7
General Safety Statement	8
Electrical Power Supply	8
Material Safety Data Sheets (MSDS)	8
Chapter 3 Safety Decals	9
Safety Decal # DC-GBC-1A	10
Safety Decal # DC-889	11
Safety Decals # DC-985, DC-990 and DC-991	12
Safety Decals # DC-987, DC-988 and DC-989	13
Safety Decal # DC-1060	14
Safety Decal # DC-1061	14
Safety Decals # DC-1063 and DC-1064	15
Safety Decals # DC-1223 and DC-1317	16
Information Decals	17
Chapter 4 Orientation Wall Sheets and Vertical Channels	19
Dryer Structure Overview	19
Components all Models	20
Dimensions for all Models	21
Dryer Dimensions - Detail Model 2500	22
Dryer Dimensions - Detail Model 3000	23
Dryer Dimensions - Detail Model 3500	24
Dryer Dimensions - Detail Model 4000	25
Pre-assembly	26
Ladder Installation	26
Layout and Clearance	26
Foundation	27
Sheet Layouts Model 2500	28
Sheet Layouts Model 3000	29
Sheet Layouts Model 3500	30
Sheet Layouts Model 4000	31
Flat Layout Model 2500	32
Flat Layout Model 3000	33
Flat Layout Model 3500	34
Flat Layout Model 4000	35
Wall Sheets Overlap	36
Wall Sheet Comparison	37
Wall Sheet Guidelines	38
Wall Sheet Attachment Guidelines - All Models	39
Inside Wall Sheet Placement - All Models	39
Outside Wall Sheet Placement - All Models	40
Example - Installing Wall Sheets to Roof	41
Lifting Dryer Guidelines	42
Vertical Channel Comparison	43
Column Layout	44
Component Placement - All Models	45

Table of Contents

Chapter 5 Plenum Roof	46
Plenum Roof Components (Expanded View)	46
Plenum Roof (Aerial View)	47
Plenum Roof (Cross Section)	48
Jig Clip and Vertical Channel Placement (All Models)	49
Steps to Construct Plenum Roof	52
Chapter 6 Tower Roof	67
Tower Roof (Assembled Over Plenum Roof - Cross Section)	67
Tower Roof (Aerial View)	68
Tower Roof Access Port	69
Steps to Construct Tower Roof	70
Tower Roof Hardware	73
Attachment of Roof Stairs Section	84
Bottom Section Attachment	85
Chapter 7 Outside Ladder	86
Outside Ladder with Top Safety Cage	86
Installing Outside Ladder with Safety Cage	87
Chapter 8 Sensors	97
Sensors Placement	97
Indicator(s) Placement - Detail	98
Sensors (Outside)	99
Chapter 9 Lift Dryer	109
Steps to Lift Dryer	109
Chapter 10 Catwalks and Platforms	114
Outside Catwalk	114
Inside Catwalk	115
Platform	116
Outside Catwalk and Inside Catwalk Positions - Model 2500	117
First Outside Catwalk Position - Model 3000	118
Second Outside Catwalk and Inside Catwalk Positions - Model 3000	119
First Outside Catwalk Position - Model 3500	120
Second Outside Catwalk and Inside Catwalk Positions - Model 3500	121
First Outside Catwalk Position - Model 4000	122
Second Outside Catwalk and Inside Catwalk Positions - Model 4000	123
Steps - Catwalks and Platforms	124
Chapter 11 Inside Ladders	133
Four (4) Auxiliary Ladders Burner Housing Ladder	133
Four (4) Auxiliary Ladders (Optional)	134
One (1) Burner Housing Ladder	137
Chapter 12 Slide Gates	139
Chapter 13 Grain Turners	141
Chapter 14 Burner and Reducer	144
Burner Housing Model 2500/3000/3500	144
Burner Housing Model 4000	145
Burner and Reducer Example: Model 3000	146
Reducer	152

Chapter 15 Fans, Divider Hopper, Reducer Walkway	154
Fan Splicing and Reducer Walkway - All Models	154
Fan X-Bracing - All Models	155
Fan X-Bracing, Divider Hopper, and Reducer Walkway Model 2500	156
Fan X-Bracing, Divider Hopper, and Reducer Walkway Model 3000	157
Fan X-Bracing, Divider Hopper, and Reducer Walkway Model 3500	158
Fan X-Bracing, Divider Hopper, and Reducer Walkway Model 4000	159
Fans (3), Divider Hopper, Reducer Walkway	160
Chapter 16 Fan Motors	176
Fan Motor Mounts, Fan Motors, Sheaves and Fan Belts	176
Chapter 17 Grease Tubes	184
Chapter 18 Windows and Doors	187
Overview	187
Pre-assembly of Window Kits	189
Installation of Window Kits (18" and 24")	191
Screened Windows	194
Louvered Windows	196
Cool Section Door	197
Heat Section Door	198
Reducer Door	201
Chapter 19 Tower Base	204
Compression Angle Weldments Example - All Models	204
Dryer Legs Example - All Models	205
X-Bracing Rod Placement Example - All Models	206
Chapter 20 Cool Section Floor	219
Chapter 21 Hopper	221
Hopper (Cross Section) Example - All Models	221
Chapter 22 Metering System	230
Metering System Example - All Models	230
Chapter 23 Fuel Piping	238
Fuel Piping (Main) (Natural Gas or Liquid Propane)	238
Fittings for Fuel Piping	239
Fuel Piping Guidelines	240
Chapter 24 Fuel Train	244
Natural Gas or Liquid Propane	245
Components (shipped Pre-assembled)	246
Demonstration Close Ups	247
Installation Guidelines	250
Chapter 25 Electrical Control System	254
Chapter 26 All Tower Dryer Models Drawings	255
Chapter 27 Appendix A	435
Tools and Equipment	435
Chapter 28 Appendix B	437
Hardware	437
Hardware - Galvanized	439
Chapter 29 Appendix C	441
Assembly Terms	441
Chapter 30 Appendix D	443
U.S. to Metric Conversion Tables	443
Chapter 31 Warranty	445

1. Introduction

READ THIS MANUAL carefully to learn how to properly use and install equipment. Failure to do so could result in personal injury or equipment damage.

INSPECT the shipment immediately upon arrival. The customer is responsible for ensuring that all quantities are correct. The customer should report and note any damage or shortage on the bill of lading to justify their claim to the transport company.

THIS MANUAL SHOULD BE CONSIDERED a permanent part of your equipment and should be easily accessible when needed.

This warranty provides you the assurance that the company will back its products when defects appear within the warranty period. In some circumstances, the company also provides field improvements, often without charge to the customer, even if the product is out of warranty. Should the equipment be abused, or modified to change its performance beyond the factory specifications, the warranty will become void and field improvements may be denied.

Safety Guidelines

This manual contains information that is important for you, the owner/operator, to know and understand. This information relates to protecting **personal safety** and **preventing equipment problems**. It is the responsibility of the owner/operator to inform anyone operating or working in the area of this equipment of these safety guidelines. To help you recognize this information, we use the symbols that are defined below. Please read the manual and pay attention to these sections. Failure to read this manual and its safety instructions is a misuse of the equipment and may lead to serious injury or death.



This is the safety alert symbol. It is used to alert you to potential personal injury hazards. Obey all safety messages that follow this symbol to avoid possible injury or death.



DANGER indicates an imminently hazardous situation which, if not avoided, will result in death or serious injury.



WARNING indicates a potentially hazardous situation which, if not avoided, could result in death or serious injury.



CAUTION indicates a potentially hazardous situation which, if not avoided, may result in minor or moderate injury.



CAUTION used without the safety alert symbol indicates a potentially hazardous situation which, if not avoided, may result in property damage.



NOTE indicates information about the equipment that you should pay special attention.

2. Safety

General Safety Statement

Our foremost concern is your safety and the safety of others associated with tower dryer. This manual is to help you understand safe operating procedures and some problems which may be encountered by the operator and other personnel.

As owner and/or operator, you are responsible to know what requirements, hazards and precautions exist and inform all personnel associated with the equipment or in the area. Safety precautions may be required from the personnel. Avoid any alterations to the equipment, which may produce a very dangerous situation, where **SERIOUS INJURY** or **DEATH** may occur.

You should consider the location of the tower dryer site relative to power line locations or electrical transmission equipment. Contact your local power company to review your installation plan or for information concerning required equipment clearance. Clearance of portable equipment that may be taken to the tower dryer site should also be reviewed and considered. Any electrical control equipment in contact with the tower dryer should be properly grounded and installed in accordance with National Electric Code provisions and other local or national codes.

This product is intended for the use of grain drying. Any other use is a misuse of the product.



This product has sharp edges, which may cause serious injury. To avoid injury, handle sharp edges with caution and always use proper protective clothing and equipment.

Sidewall bundles or sheets must be stored in a safe manner. The safest method of storing sidewall bundles is laying horizontally with the arch of the sheet upward, like a dome. Sidewall sheets stored on edge must be secured so that they cannot fall over and cause injury. Use care when handling and moving sidewall bundles.

Personnel operating or working around equipment should read this manual. This manual must be delivered with equipment to its owner. Failure to read this manual and its safety instructions is a misuse of the equipment.

NOTE: *A careful operator reduces risk of personal injury and equipment damage.*

Electrical Power Supply

GSI recommends you contact your local power company and request that a representative inspect the dryer installation. Be sure the wiring is compatible with the power company's system and that adequate power supplied to dryer.

Material Safety Data Sheets (MSDS)

MSDS are available upon request.



Some of the required safety decals are placed on the dryer before shipping. The remainder are placed on the dryer during electrical installations. The purpose of the safety decals is to immediately alert all personnel to the hazards of an operating dryer. The safety decal does not replace the need for all personnel to know and understand safe dryer operations and requirements. Read the “Dryer Operations and Service Manual”.

NOTE: *Safety decals should be read and understood by all people in or around the dryer area.*

Safety decals on [Pages 10-16](#) identify and give the location of all safety decals that should be on each tower dryer. Safety decals are listed in numerical order.

If the safety decals on the following pages are not on the dryer, or if they are damaged, immediately contact grain systems for replacement safety decals.

GSI Decals

1004 E. Illinois St.
Assumption, IL. 62510
Phone: 1-217-226-4421

3. Safety Decals



Safety Decal # DC-GBC-1A

Location of Decals

1. English and spanish decals are placed on inside of tower roof access port before shipping.



! DANGER

 Rotating flighting will kill or dismember.	 Flowing material will trap and suffocate.	 Crusted material will collapse and suffocate.
--	---	---

**Keep clear of all augers.
DO NOT ENTER this bin!**

If you must enter the bin:

1. Shut off and lock out all power.
2. Use a safety harness and safety line.
3. Station another person outside the bin.
4. Avoid the center of the bin.
5. Wear proper breathing equipment or respirator.

Failure to heed these warnings will result in serious injury or death.

DC-GBC-1A



Tower roof access port with decals in place.



Inside view - Access port installed with decals in place.



Outside view - Access port installed with decals in place.

Safety Decal # DC-889

Location of Decal

1. On outside of main power box, on right door.
2. On outside of main power box, on left door.
3. Inside main power box door, on same side as main electrical disconnect.

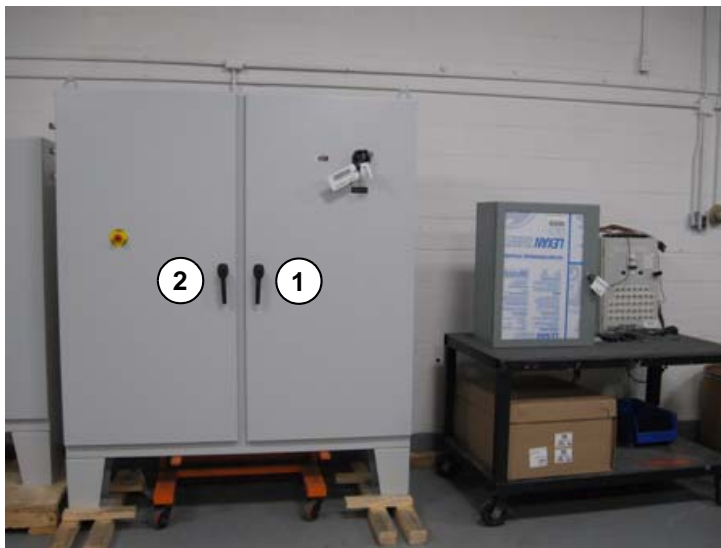

Example - Electrical control system

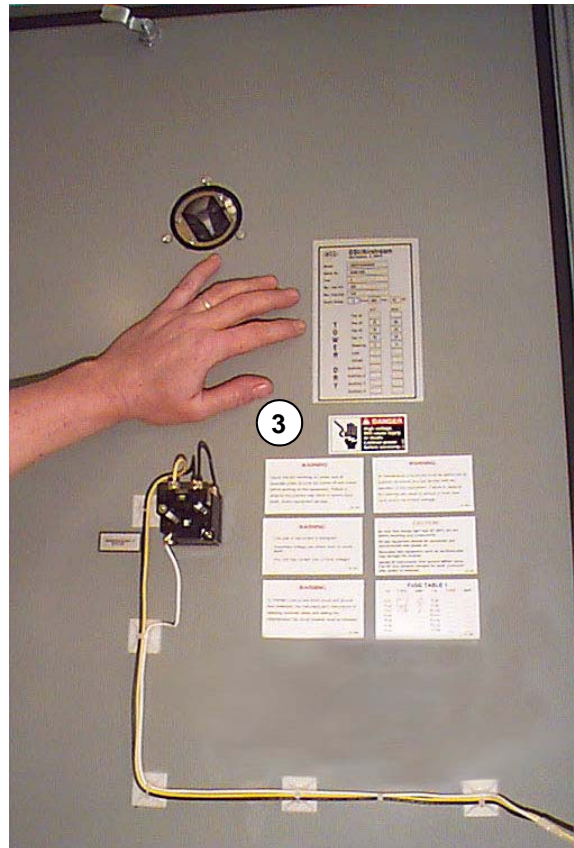

3. Safety Decals

Safety Decals # DC-985, DC-990 and DC-991

Location of Decal

Inside main power box door, on same side as main electrical disconnect.

WARNING

All maintenance procedures must be performed by qualified personnel who are familiar with the operation of this equipment. Failure to observe this warning can result in serious or even fatal injury and/or equipment damage.

DC-990

Be sure that charge light and all LED's are out before touching any components.

All test equipment should be connected and disconnected with power OFF.

Grounded test equipment, such as oscilloscopes, may damage the inverter.

Isolate all instruments from ground before using. The DC bus remains charged for several minutes after power is removed.

DC-991



FUSE TABLE 1

F#	TYPE	AMP	F#	TYPE	AMP
FU1	_____	_____	FU8	_____	_____
FU2	_____	_____	FU9	_____	_____
FU3	_____	_____	FU10	_____	_____
FU4	_____	_____	FU11	_____	_____
FU5	_____	_____	FU12	_____	_____
FU6	_____	_____	FU13	_____	_____
FU7	_____	_____	FU14	_____	_____

DC-985

Safety Decals # DC-987, DC-988 and DC-989

Location of Decal

Inside main power box door, on same side as main electrical disconnect.

WARNING

Ensure that the incoming AC power and all separate power sources are turned OFF and locked before working on this equipment. Failure to observe this practice may result in severe injury, death, and/or equipment damage.

DC-989

WARNING

Line side of disconnect is energized.
Hazardous voltage can shock, burn or cause death.
This unit may contain one or more voltages.

DC-987

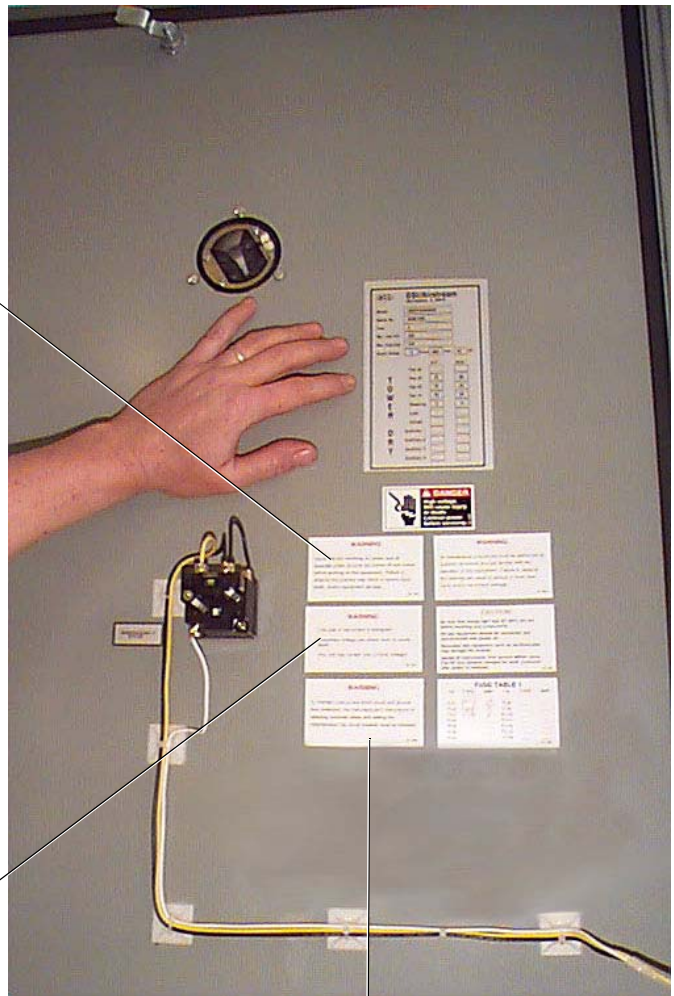

WARNING

To maintain overcurrent short circuit and ground fault protection, the manufacturer's instructions for selecting overload relays and setting the instantaneous trip circuit breaker must be followed.

DC-988

3. Safety Decals

Safety Decal # DC-1060

Location of Decal

1. On outside of hopper service door.
2. On outside of hopper service door.

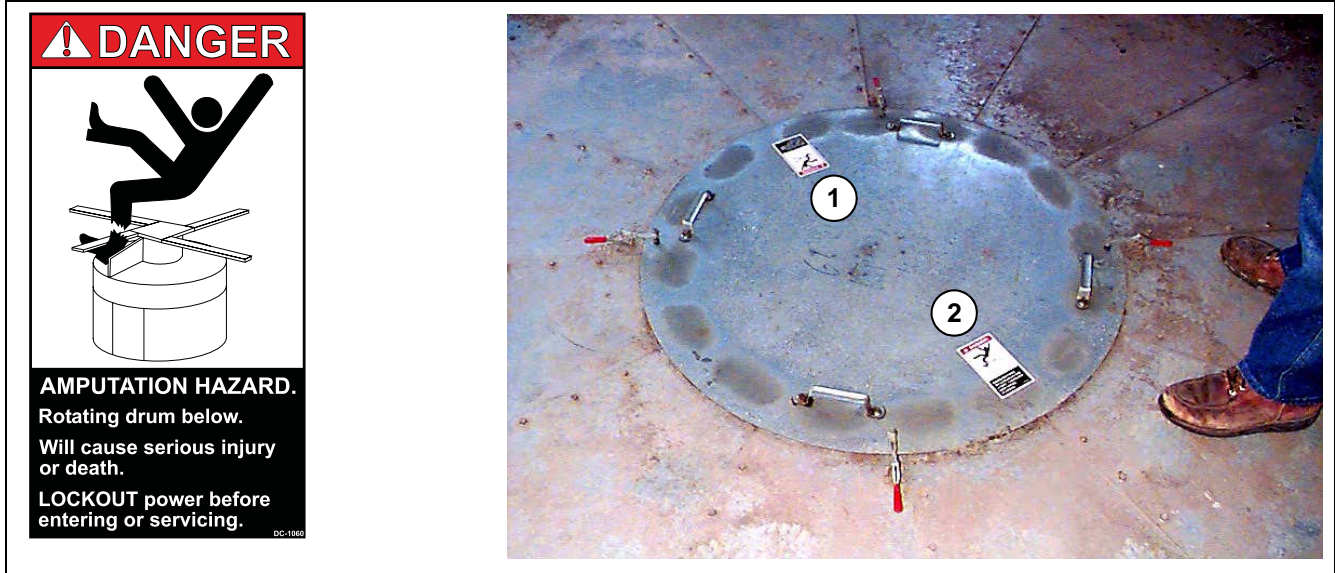

Safety Decal # DC-1061

Location of Decal

1. On outside of heat section door.

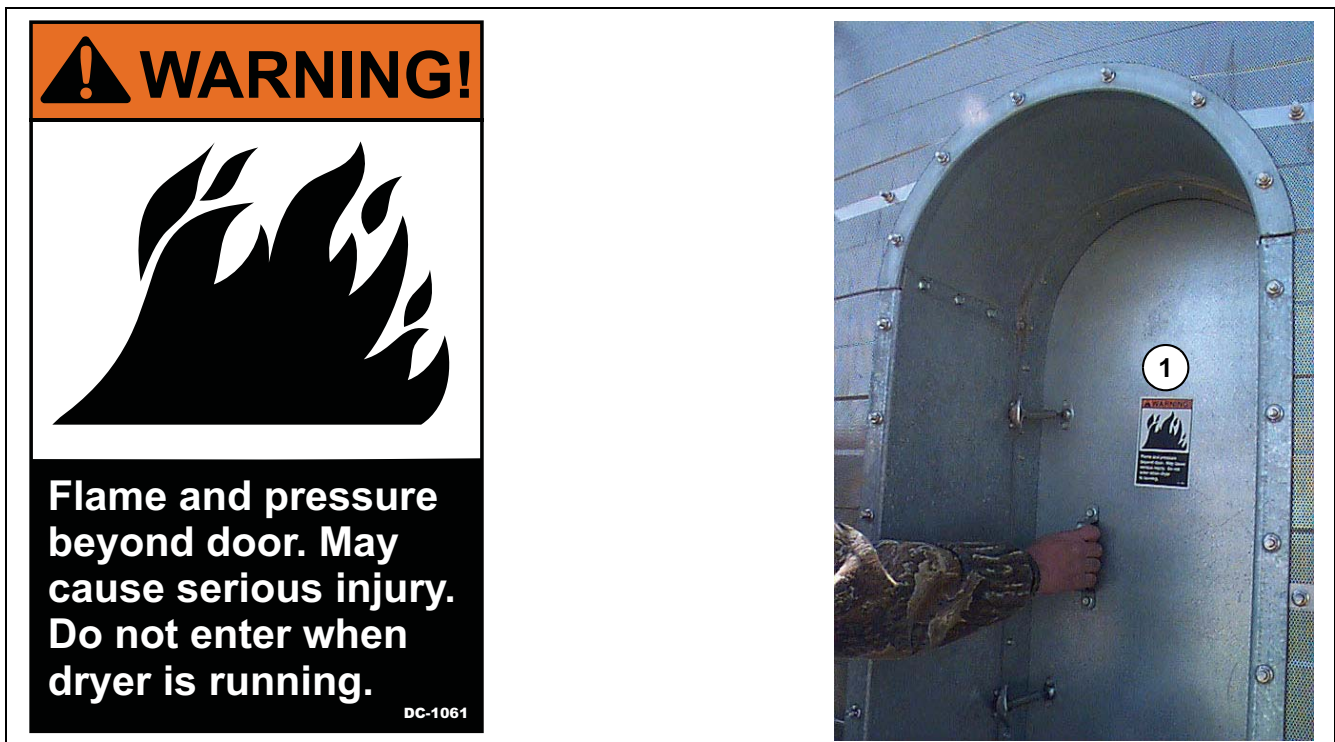

Safety Decals # DC-1063 and DC-1064

Location of Decal

On outside of cool section door.

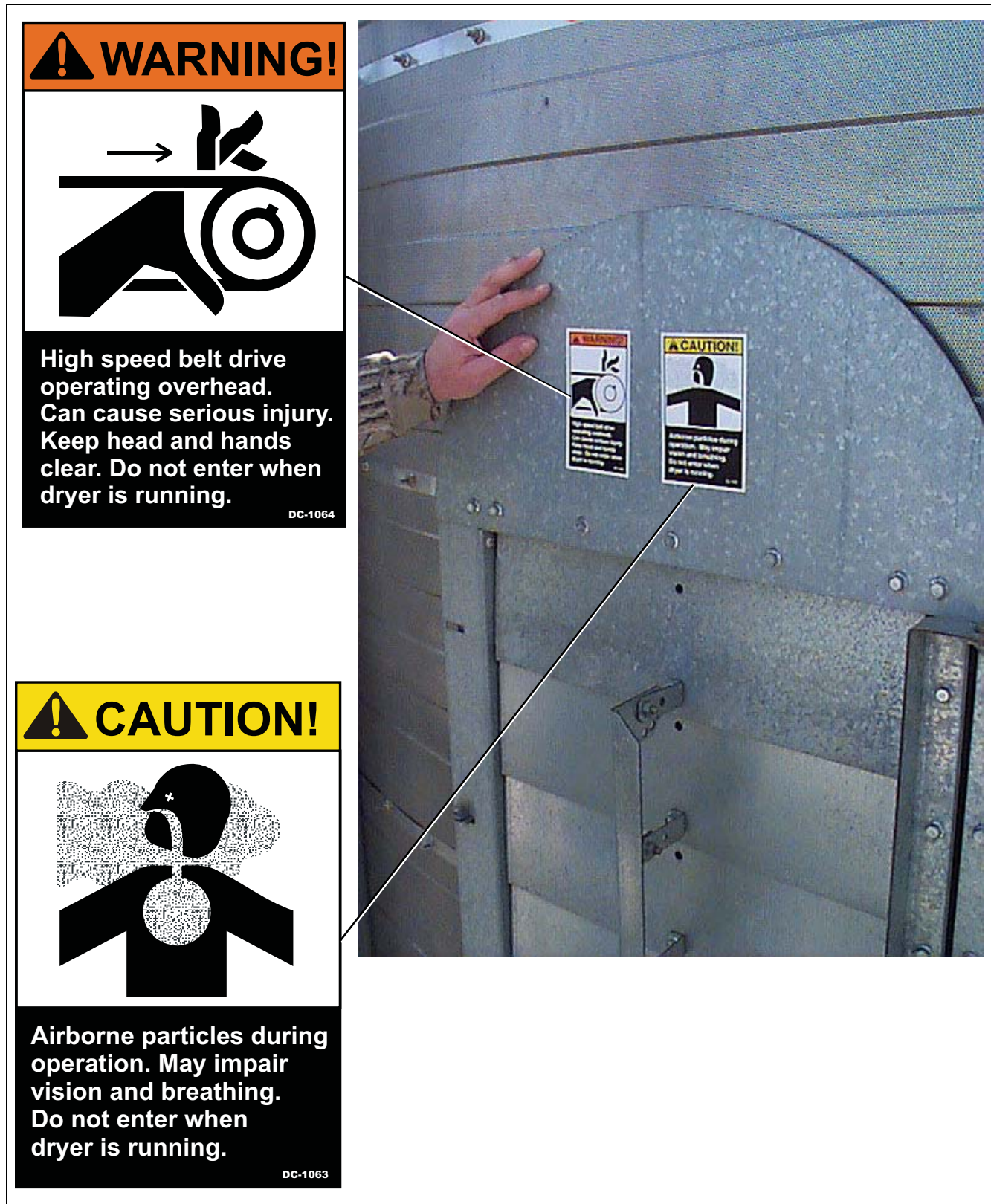

3. Safety Decals

Safety Decals # DC-1223 and DC-1317

Location of Decal

1. On outside of main power box door, to left of main electrical disconnect.
2. On outside of main power box door, above emergency stop disconnect.

Main Electrical Disconnect
Disconnects load side power.

DC-1223

①

**Emergency
Stop**

DC-1317

②

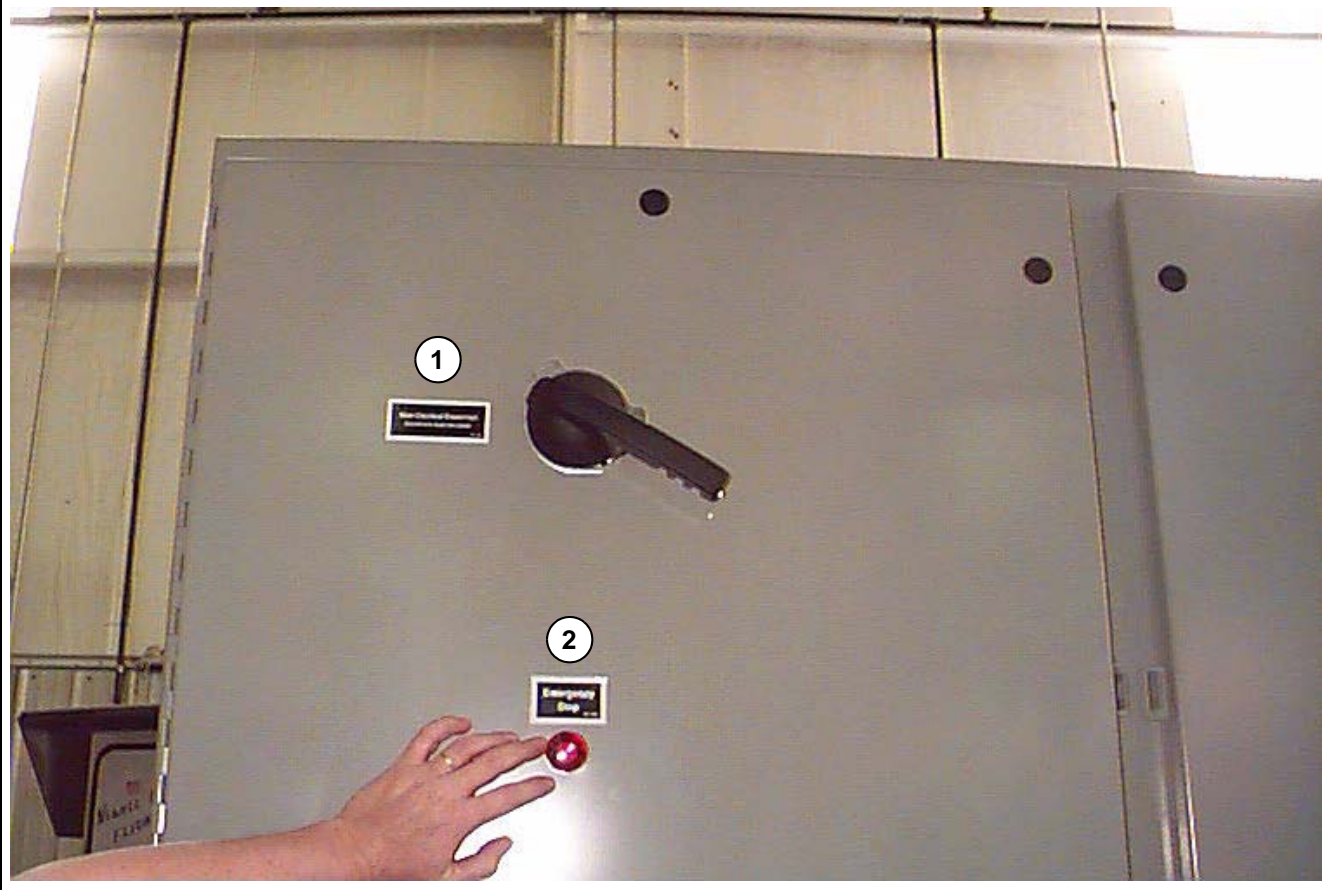

Information Decals

Name Plate for Main Power Box

Location of Decal

1. Inside main power box door, on same side as main electrical disconnect.

GSI		GSI	
		Assumption, IL 62510	
Model	4000TI34NESD		
Serial No.	03981032		
Fuel	NATURAL GAS		
Max. Total H.P.	230		
Max. Amperage	276		
Supply Voltage	3	Phase 460	Volts 60 HZ
		H.P.	Amp
T O W E R D R Y	Fan #4		
	Fan #3	75	89
	Fan #2	75	89
	Fan #1	75	89
	Metering	5	9
	Load		
	Unload		
	Auxiliary 1		
	Auxiliary 2		
	Auxiliary 3		
Auxiliary 4			

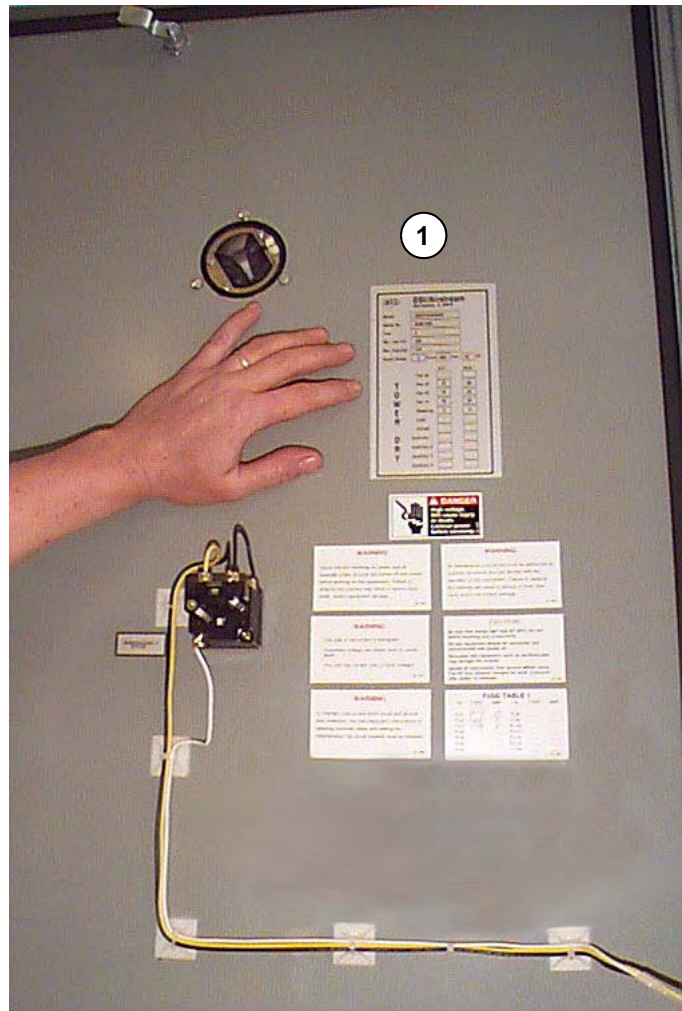

Example - Information decal

3. Safety Decals

GSI Decal

The standard location for the GSI decal is on the side of the dryer that can be seen from the operating facility and/or from access road. GSI decal will be centered on top two (2) solid wall sheets, just below roof section. Remove nuts and bolts from the seam of those two (2) solid wall sheets.

Remove backing from GSI decal. Center and apply GSI decal to top two (2) solid wall sheets. Smooth out air bubbles. Remove masking from front of GSI decal. Drill out bolt holes and replace bolts.



Dryer Structure Overview

The tower dryer is divided into three (3) sections: Heat section, cool section, and hopper. The following major features are installed in these sections.

Heat section is about 70% of dryer. Grain is loaded into top of tower dryer (between tower roof and plenum roof), and dried in heat section.

1. Grain turners, which turn grain so it dries uniformly, are located about midpoint.
2. Inside ladders and catwalk give access to slide gates (clean-out) for grain turners.
3. Burner, burner housing and reducer are installed with X-bracing.
4. There is 1 door to heat section. Larger dryers also have one (1) door to burner housing.
5. Reducer walkway gives access to burner.
6. Outside ladder with safety cage, platforms, and catwalks give access to heat section and outside sensors.
7. Heat section is separated from cool section by divider hopper. Fine grain debris falls from heat section, through divider hopper, for collection in cool section.

Cool section is about 30% of dryer. Grain is cooled in cool section.

1. Blowers are installed with X-bracing.
2. Windows provide free air. (Quantity varies according to the dryer model.)
3. There is 1 door to cool section.
4. Outside ladder with safety cage and platform give access to cool section.
5. Debris-tight cool section floor separates cool section from hopper.
6. There is at least 1 louvered door to hopper in cool section floor.

Hopper unloads grain from dryer.

1. Hopper is formed by outside and inside hopper wall sheets.
2. Metering drum, motor, and supports are installed in hopper.
3. Slide gates (discharge) provide emergency discharge of grain.
4. Compression angles form base of grain columns and support hopper.

Additional Features

Vertical channels support the dryer from foundation to roof. Vertical channels support rings of inside wall sheets and outside wall sheets to form grain columns through which grain flows down dryer. Dryer legs install with X-rods at base of vertical channels.

Components all Models

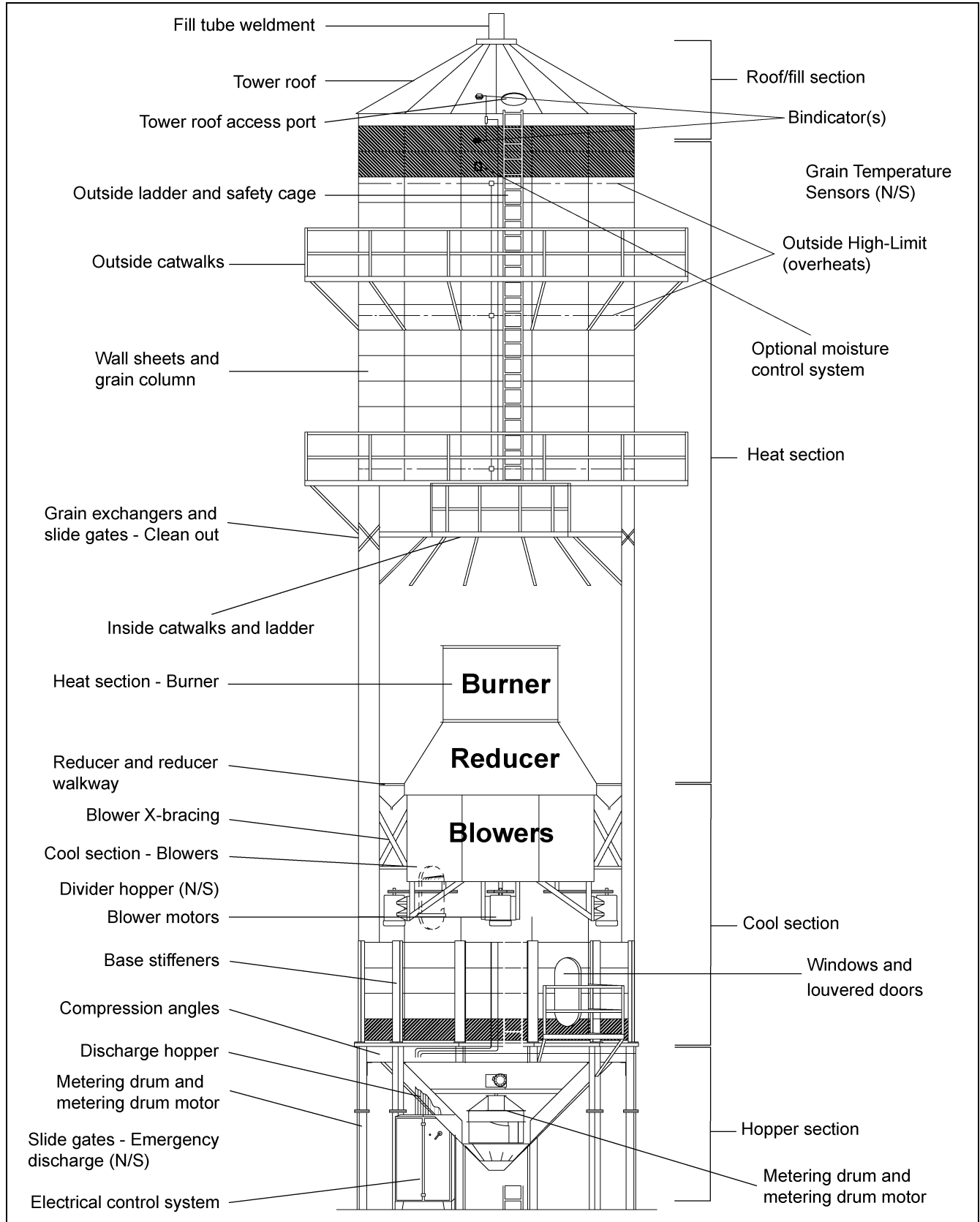

Figure 4A

Dimensions for all Models

There are four (4) models of 18' diameter dryers, #2500, #3000, #3500, and #4000. These dryers are named for their BPH (bushels per hour capacity based on 20% to 15% moisture content).

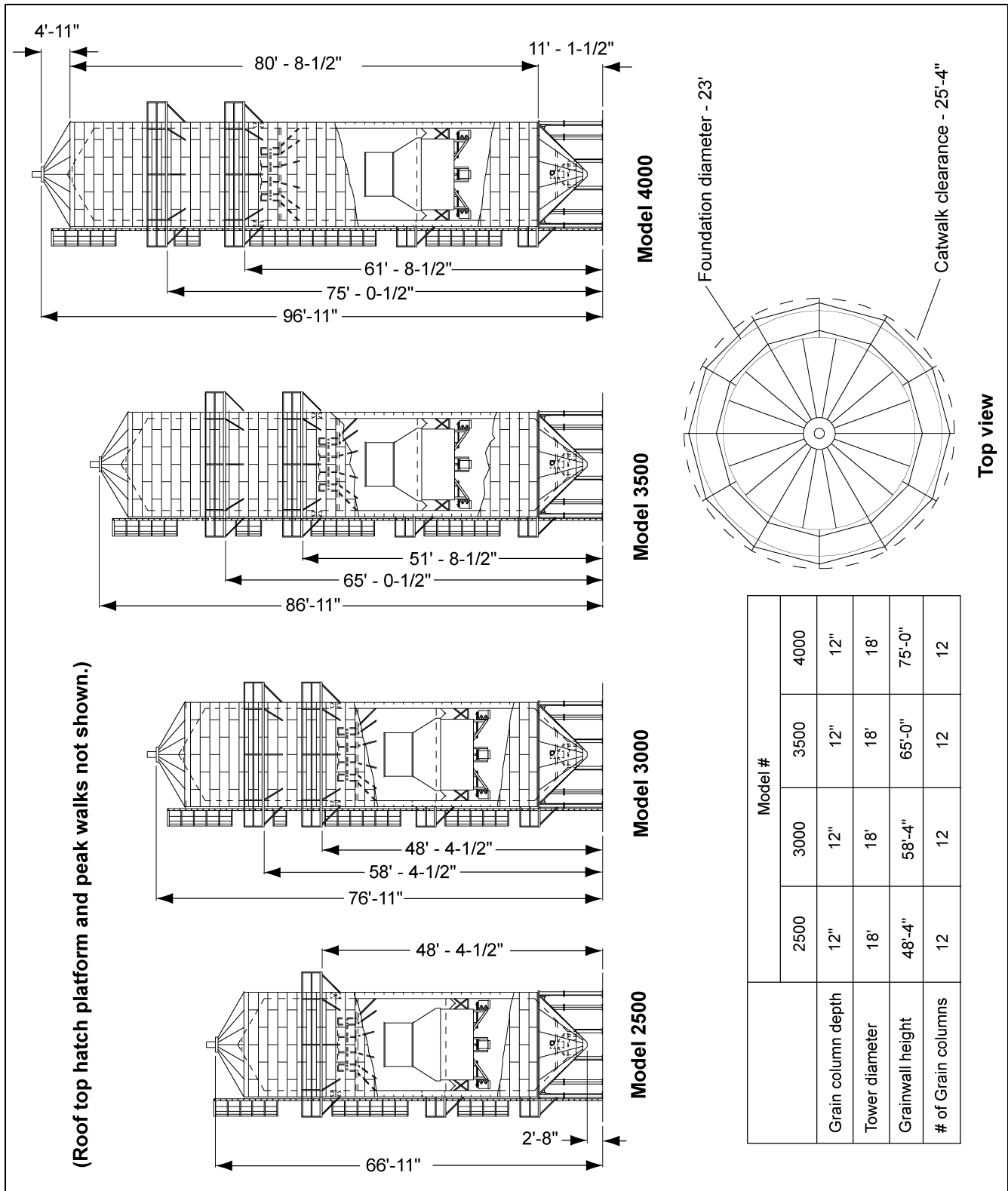

Figure 4B

Dryer Dimensions - Detail Model 2500

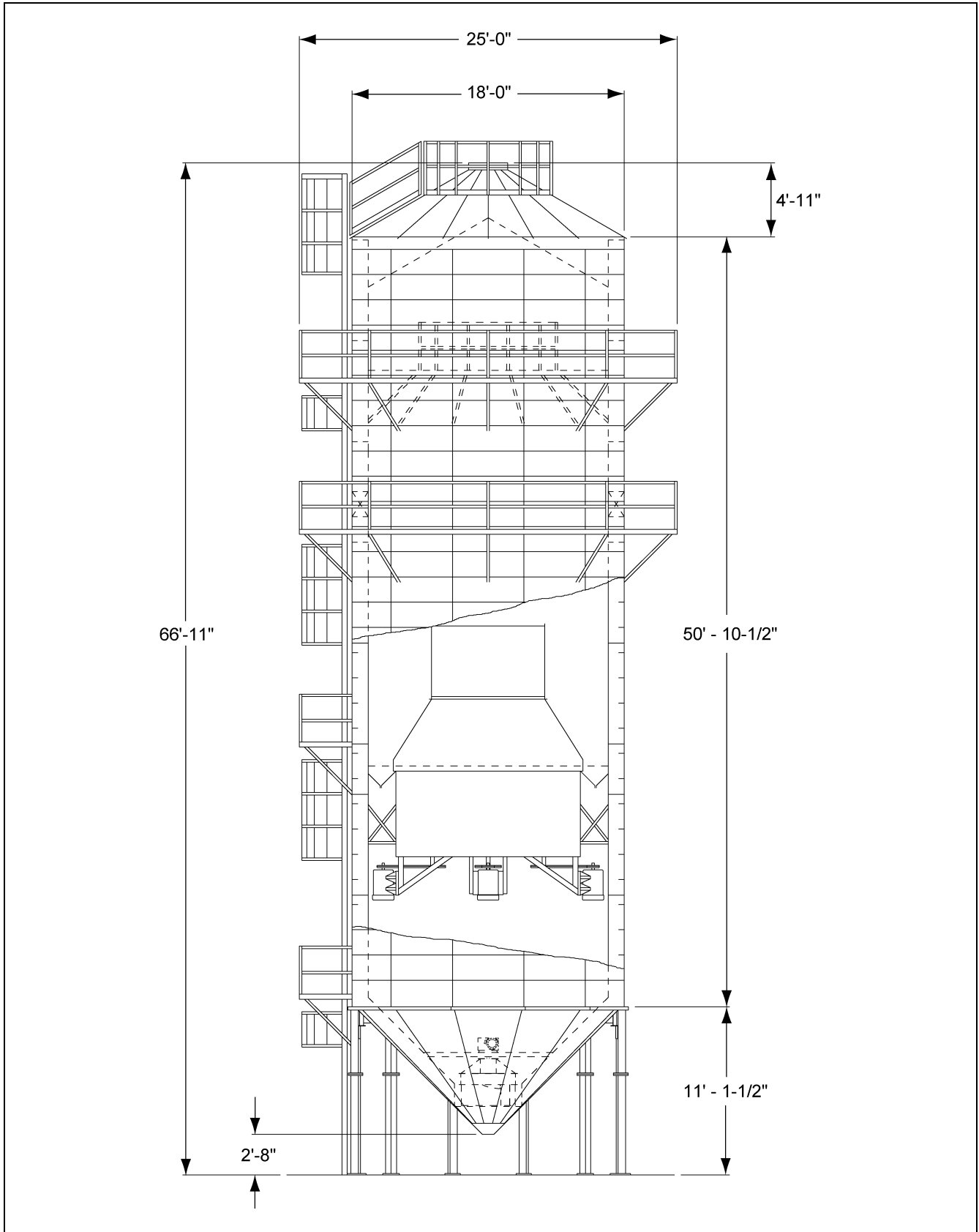

Figure 4C

Dryer Dimensions - Detail Model 3000

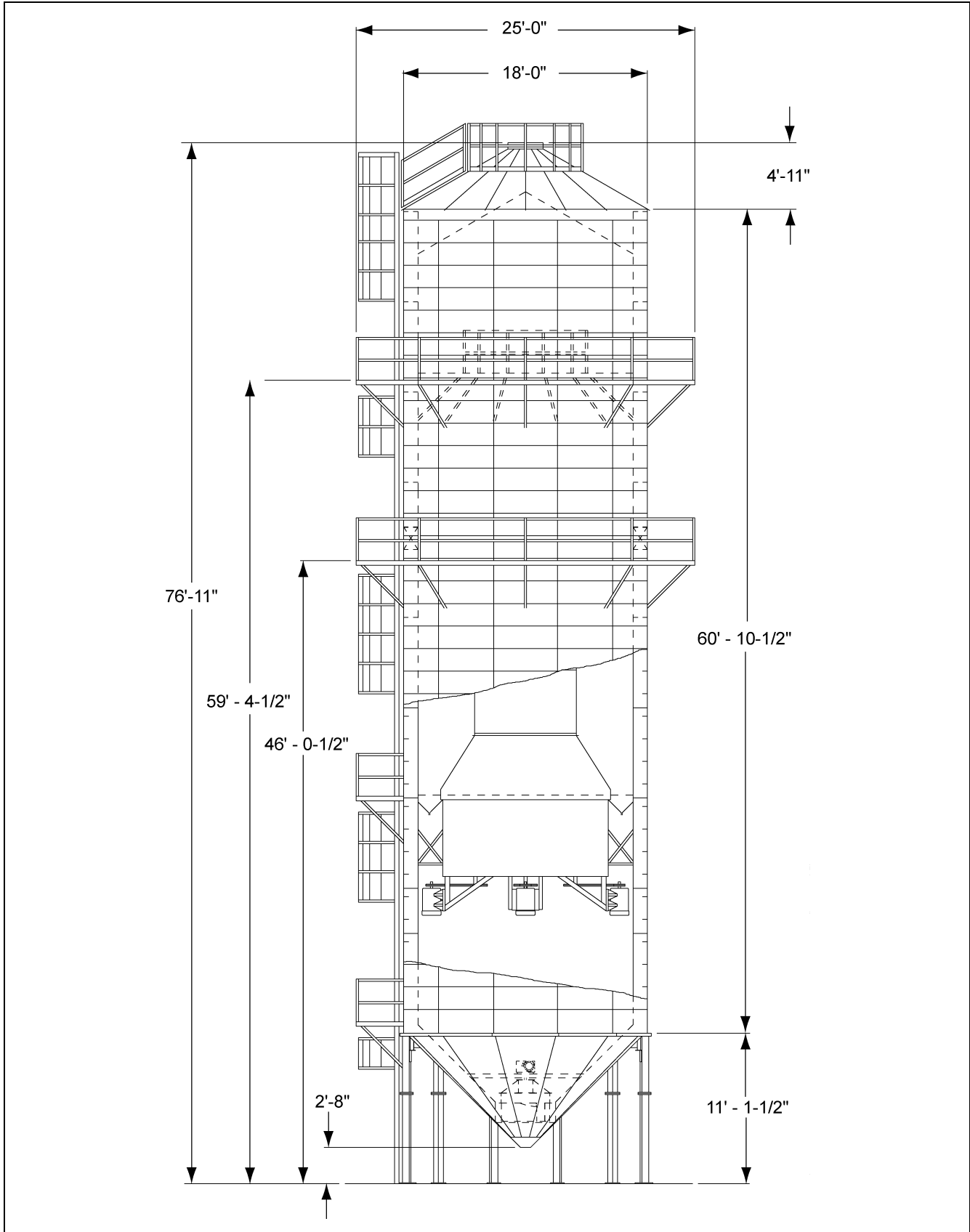

Figure 4D

Dryer Dimensions - Detail Model 3500

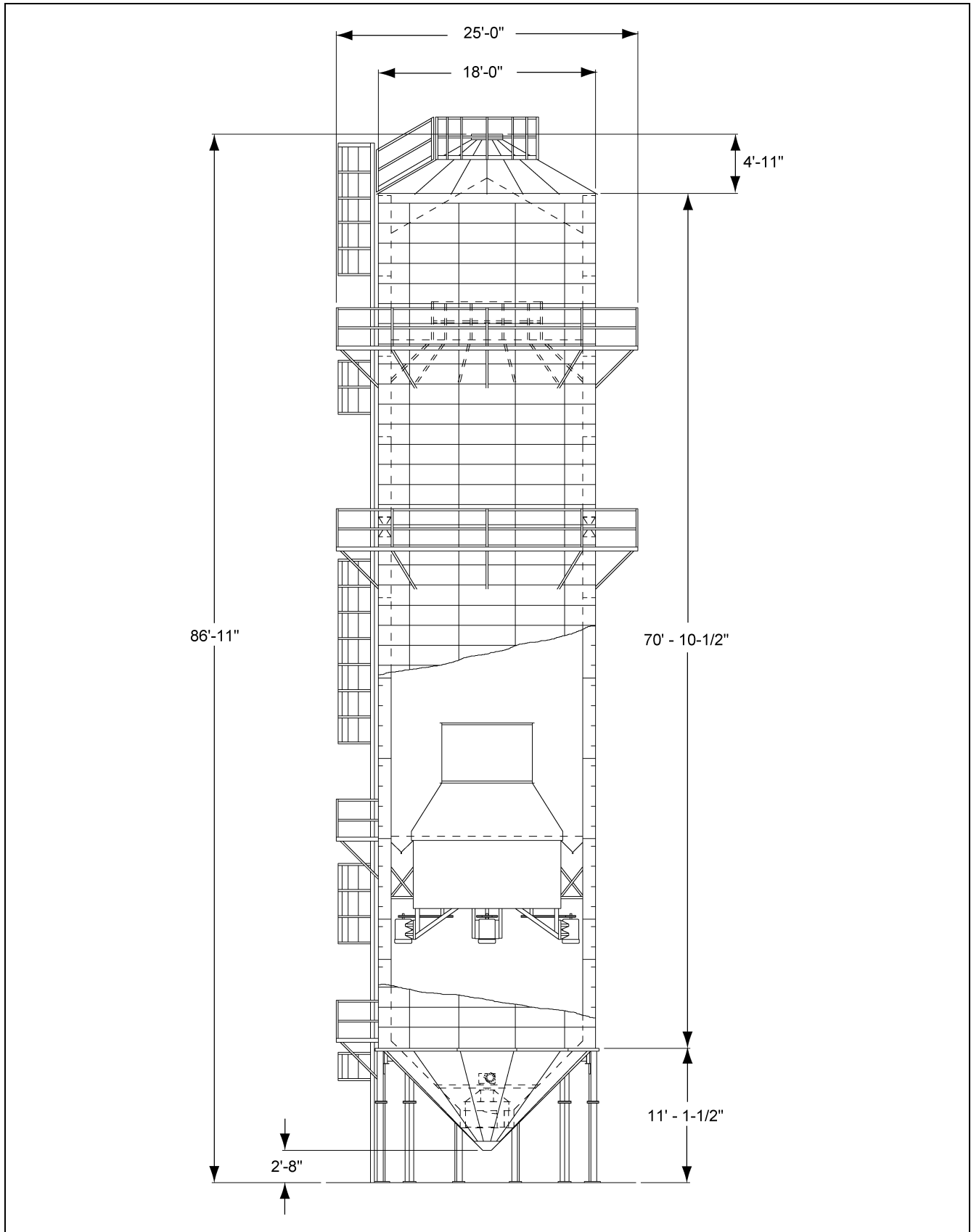

Figure 4E

Dryer Dimensions - Detail Model 4000

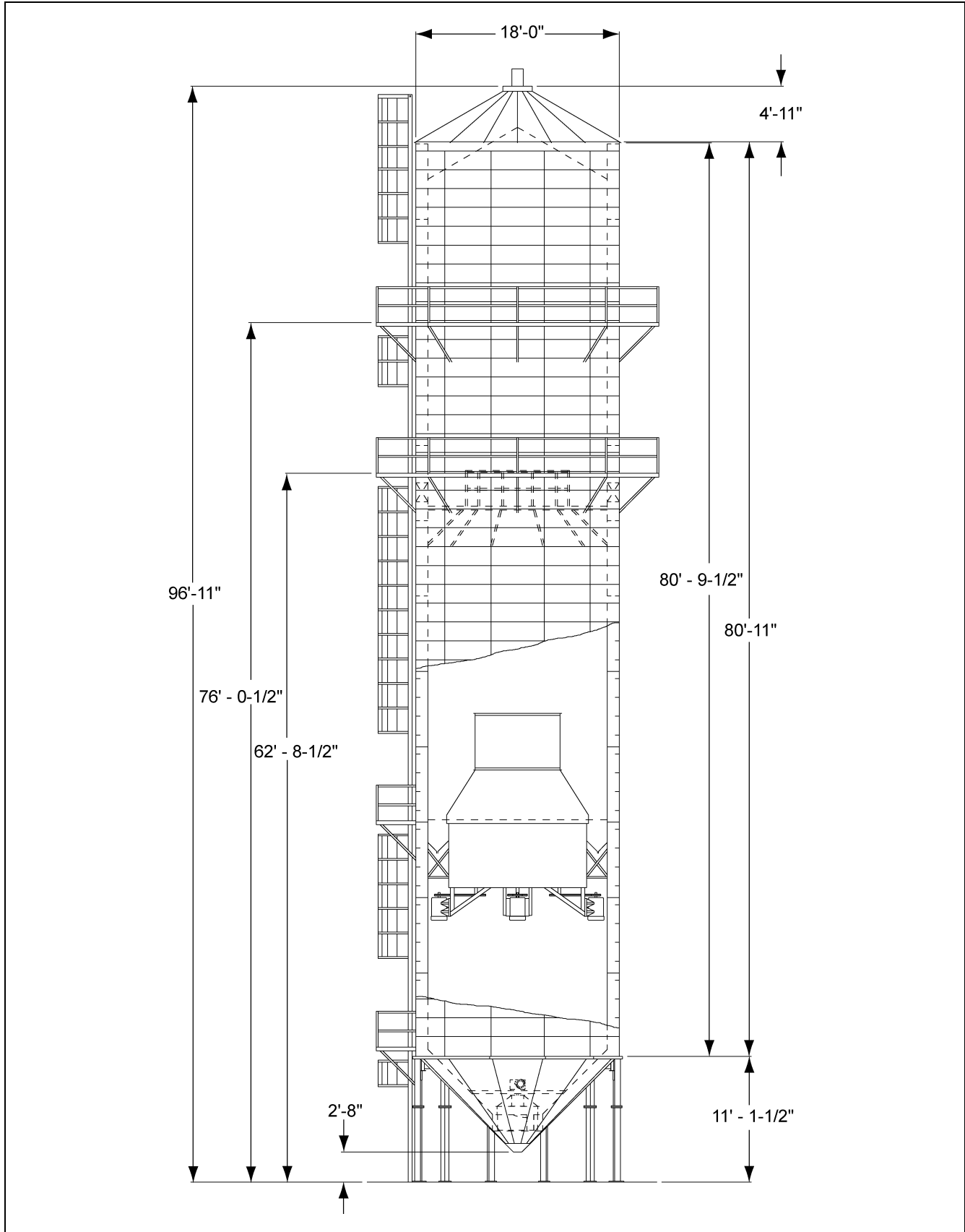

Figure 4F

4. Orientation Wall Sheets and Vertical Channels

Pre-assembly

This construction manual provides directions for installation of parts starting at the top section of the dryer and building down. Some installations can be done simultaneously, and some can be pre-assembled.

The following installations can be pre-assembled on the ground before installing them to the dryer.

1. Interior and exterior walkway sections. (Catwalk and platform.)
2. May need to pre-assemble reducer housing.
3. May need to pre-assemble burner housing.
4. Bolt a splice to each channel before installing it to the preceding channel.
5. Top safety cage can be pre-assembled on the ground before installing it to the dryer.

It is recommended that the remaining ladder and safety cage sections not be pre-assembled. Install them directly to the dryer.

Ladder Installation

1. Roof access port, indicator(s), and grain temperature sensors must be accessible from outside tower ladder.
2. Install outside ladder one (1) bolt hole to the left of a vertical channel. Install outside ladder so it will terminate with clearance from dryer legs.

Layout and Clearance

Plan ahead to locate tower dryer for the convenience of the dryer operator, and in correct orientation to existing equipment and structures.

Consider the following when planning dryer layout.

1. Dryer orientation cannot be rotated after start of construction.
2. Determine where utilities will come into dryer. Locate dryer electric and fuel intake accordingly.
3. Plan dryer leg placement so that when dryer is complete, grain unload conveyor is centered between two (2) dryer legs.
4. Landings (catwalks and platforms) are 42" wider than the perimeter (wall) of the dryer. Plan an additional 42" for lateral clearance from existing equipment and structures. Total lateral clearance radius with landings is 12'-8" from center of dryer.
5. Estimate finished dryer height and check for overhead clearance from electrical power lines, equipment and structures.
6. Follow wall sheet assembly diagram for ladder, platforms, door, windows and sensor placement. However, these components can be relocated to some degree for convenience.

Layout and Clearance (Continued)

7. Locate the electrical control system (consists of power box and control box) for the convenience of the dryer operator, where visibility and access are best.

Can locate control box directly below a motor window to allow installation of wiring conduit in a direct run. (Advisable or Recommended.)

8. The fuel train (with maxon gas valves, modutrol motor, pilot fuel train, and pilot solenoid) is usually anchored to the foundation directly below the dryer, or secured to dryer legs.
9. The fuel piping enters the dryer through a window in the cool section, then runs up the center of the dryer to the burner in the heat section. (Multi-fan models only.)

Contact grain systems for assistance in planning tower dryer layout.



***Safety check before each lift of dryer.
Check for clearance from existing power lines, equipment and structures.***

Foundation

Tower dryers should be installed on reinforced concrete foundations. (Poured to GSI specifications.)

For such foundations, engineering usually requires the following information:

1. Soil analysis and bearing strength.
2. Climatic and seismic conditions for the location.
3. Size and weights of the dryer, both empty and full of grain.
4. Specifications for the concrete and reinforcing steel to be used in the construction.

Contact grain systems for assistance in assessing tower dryer foundation requirements.

Sheet Layouts Model 2500

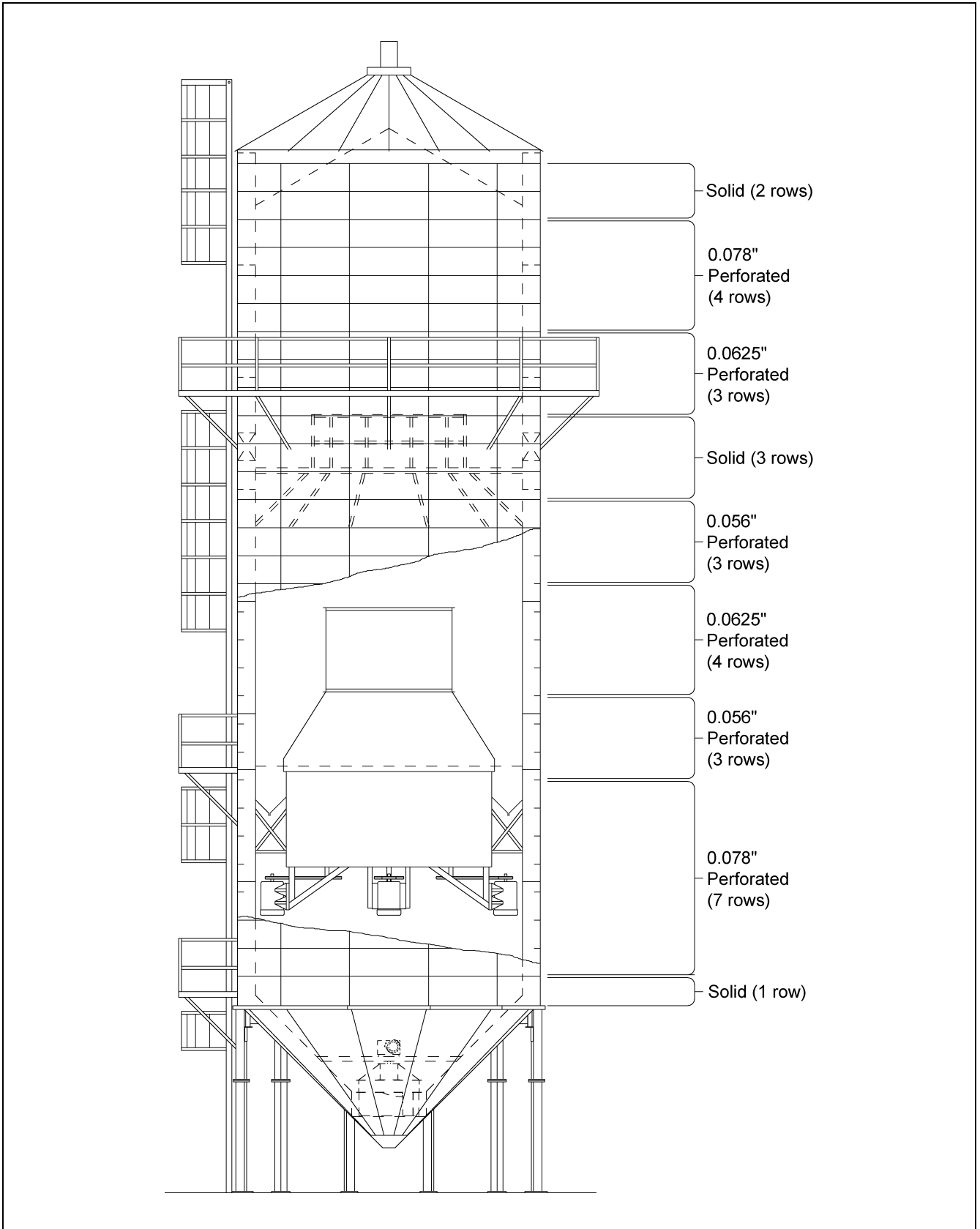

Figure 4G

Sheet Layouts Model 3000

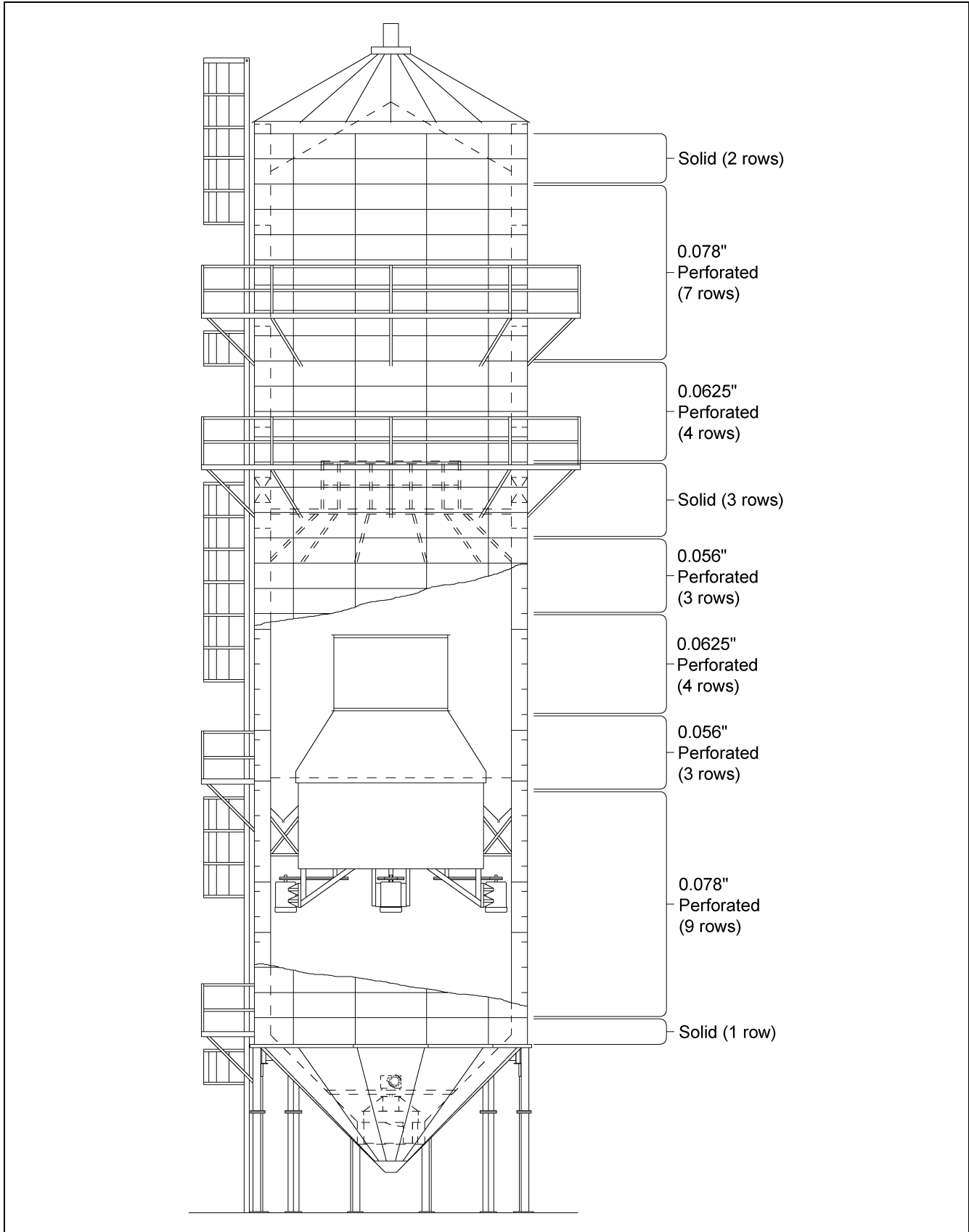

Figure 4H

Sheet Layouts Model 3500

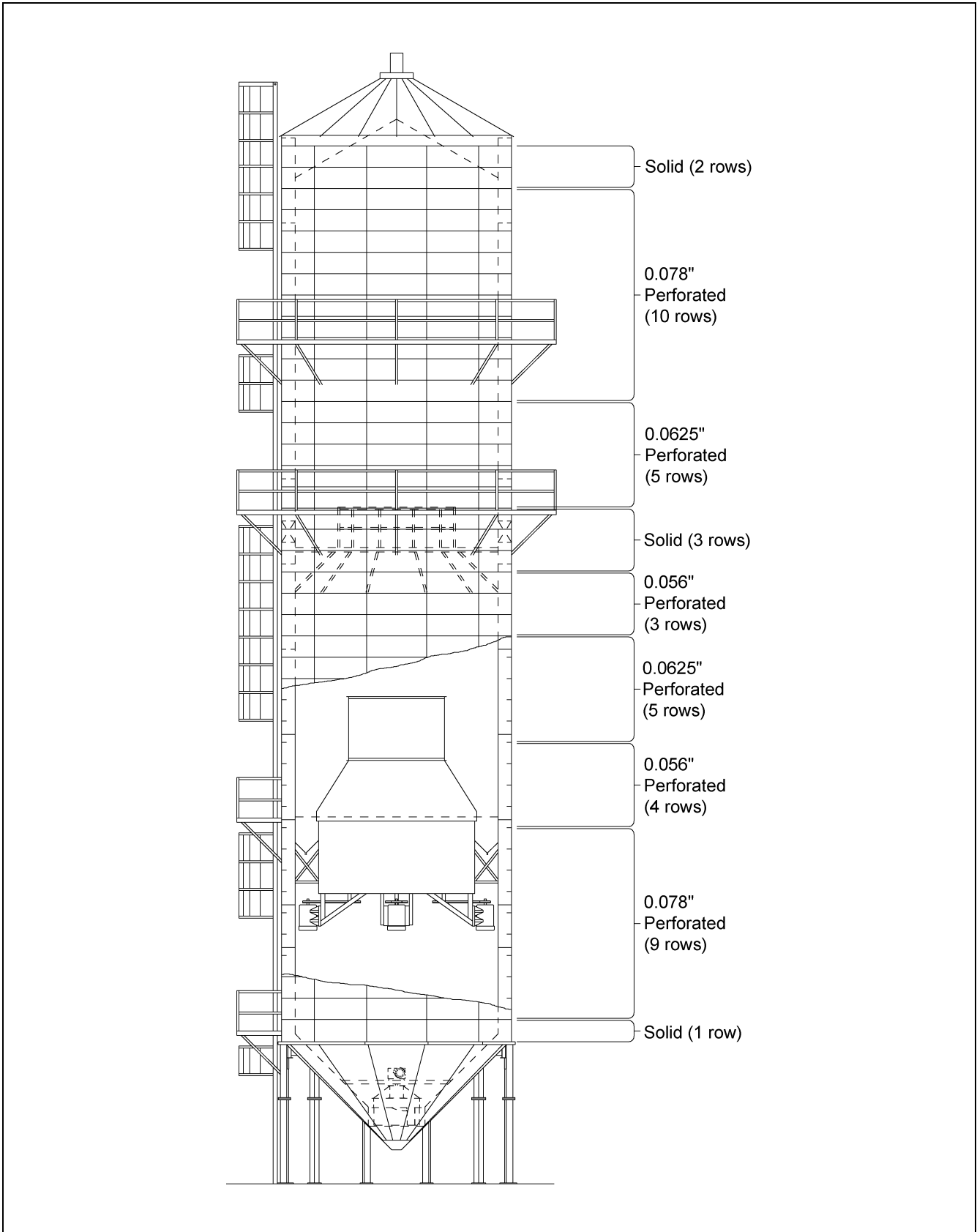

Figure 4I

Sheet Layouts Model 4000

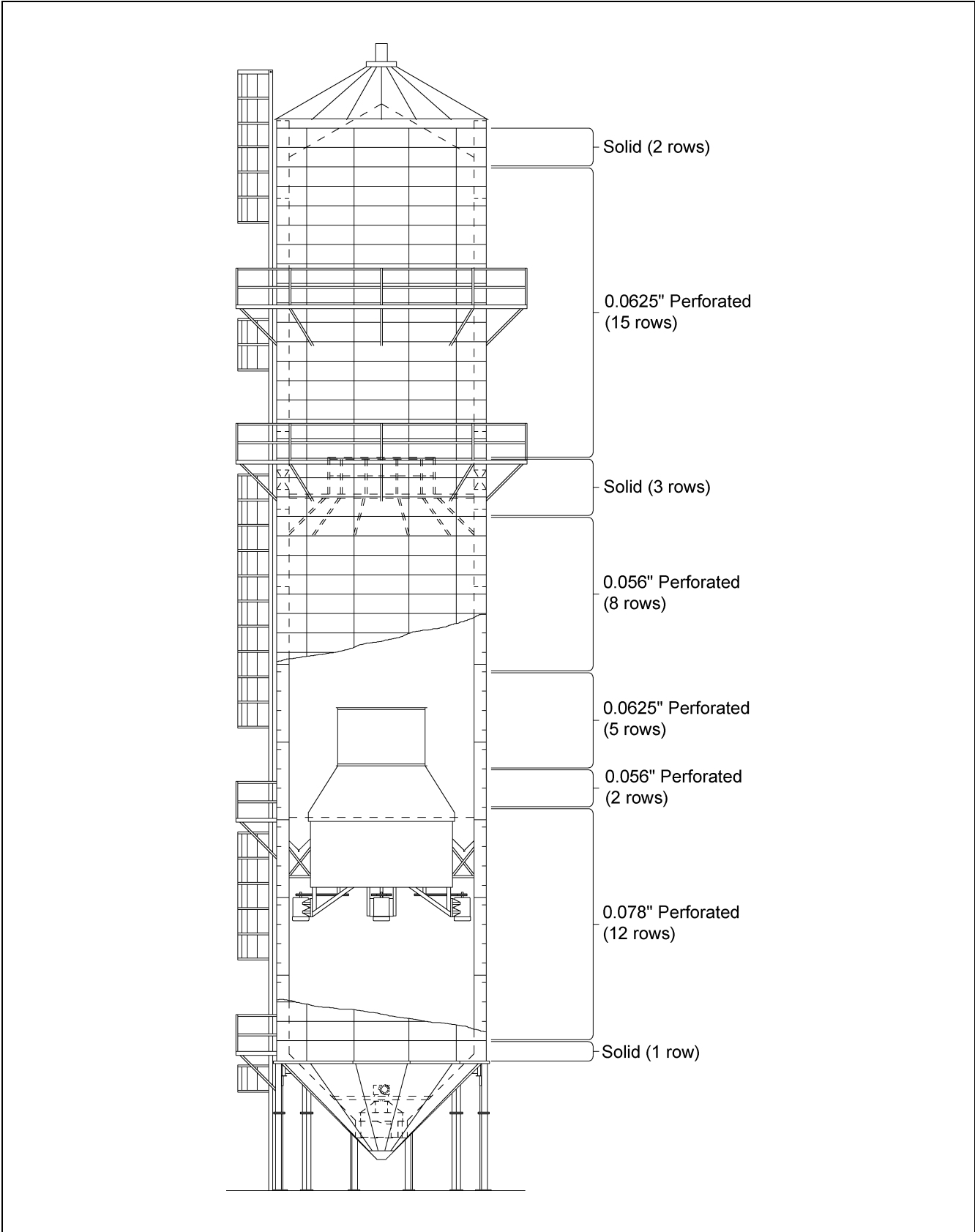

Figure 4J

Flat Layout Model 2500

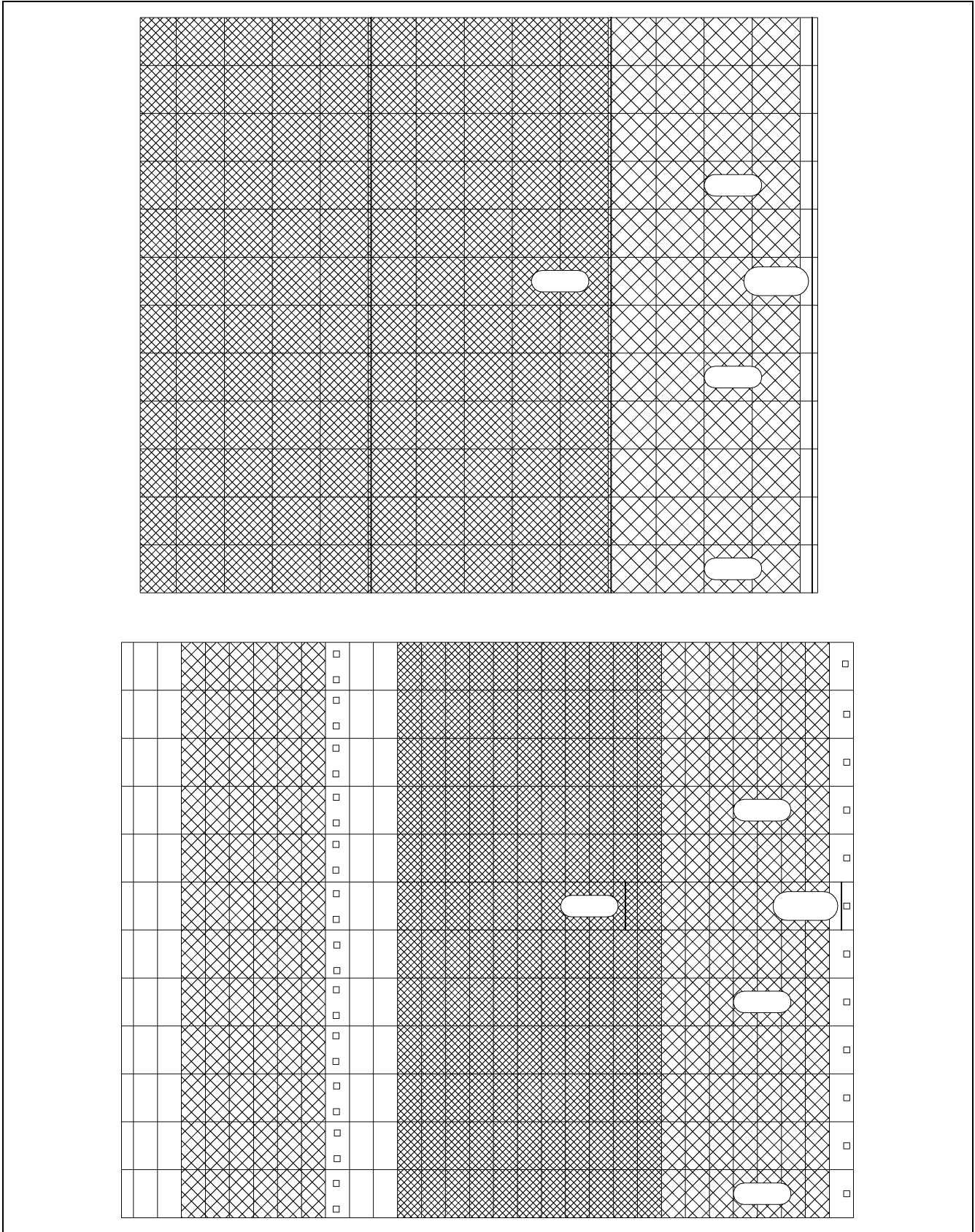

Figure 4K

Flat Layout Model 3000

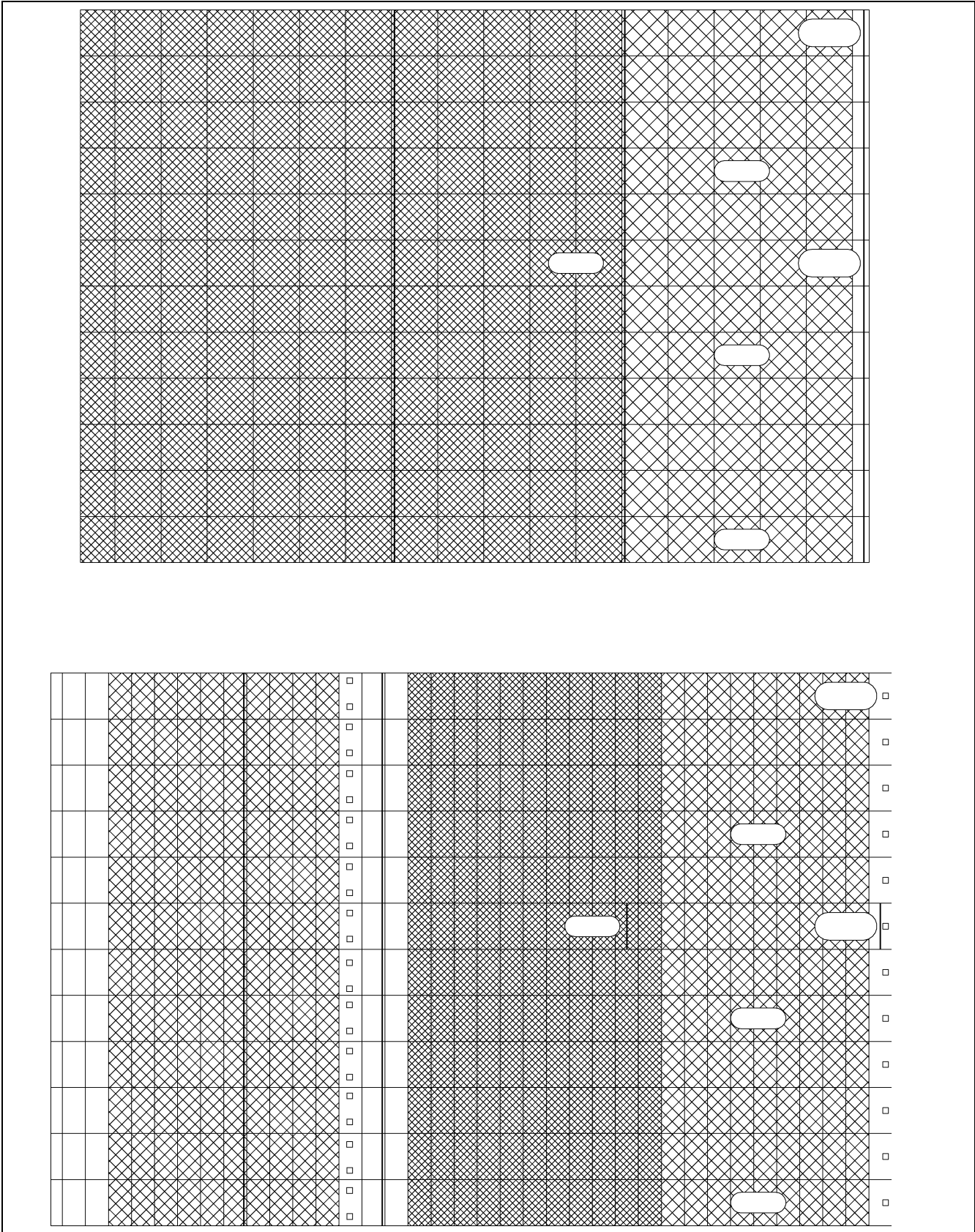

Figure 4L

Flat Layout Model 3500

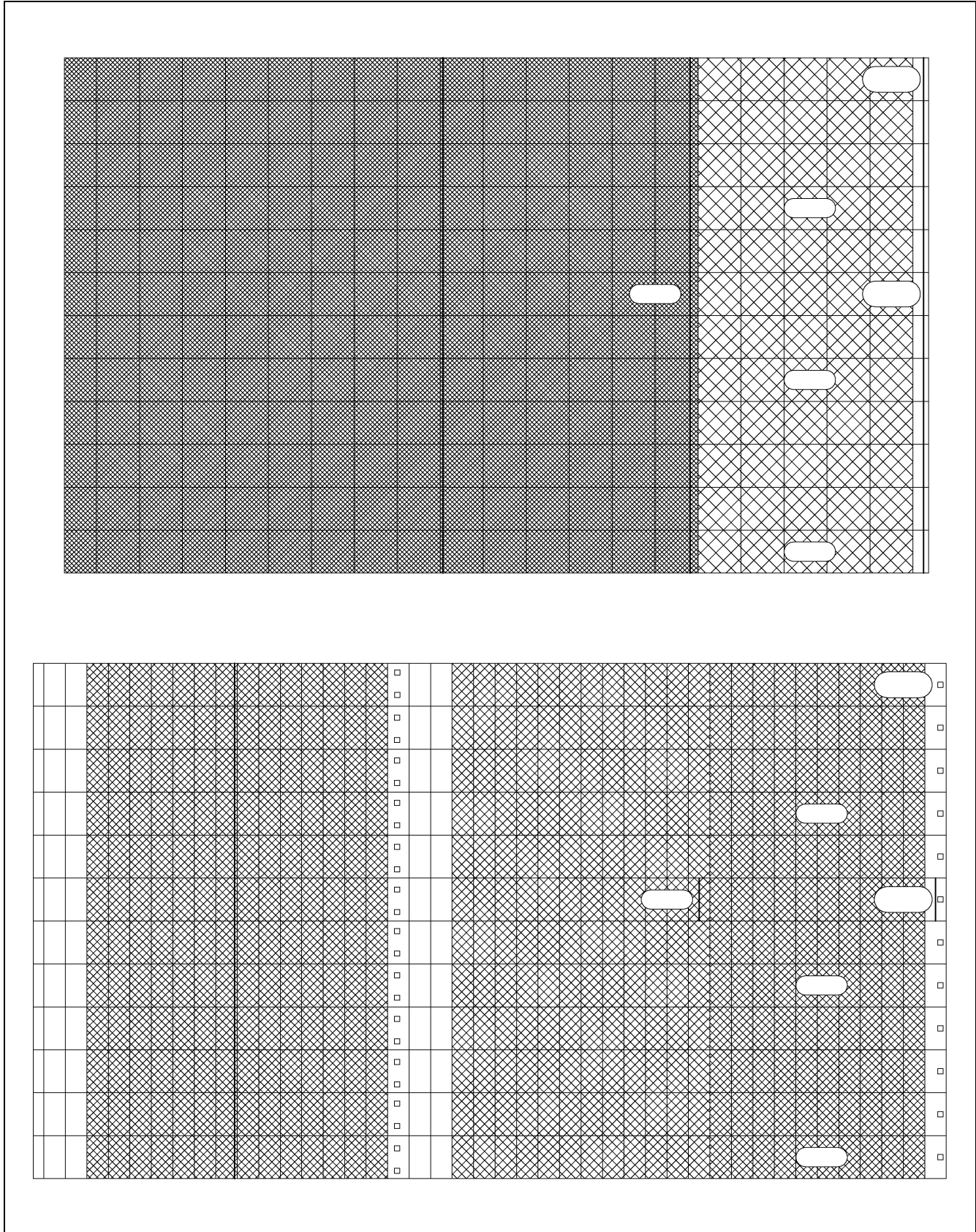

Figure 4M

Flat Layout Model 4000

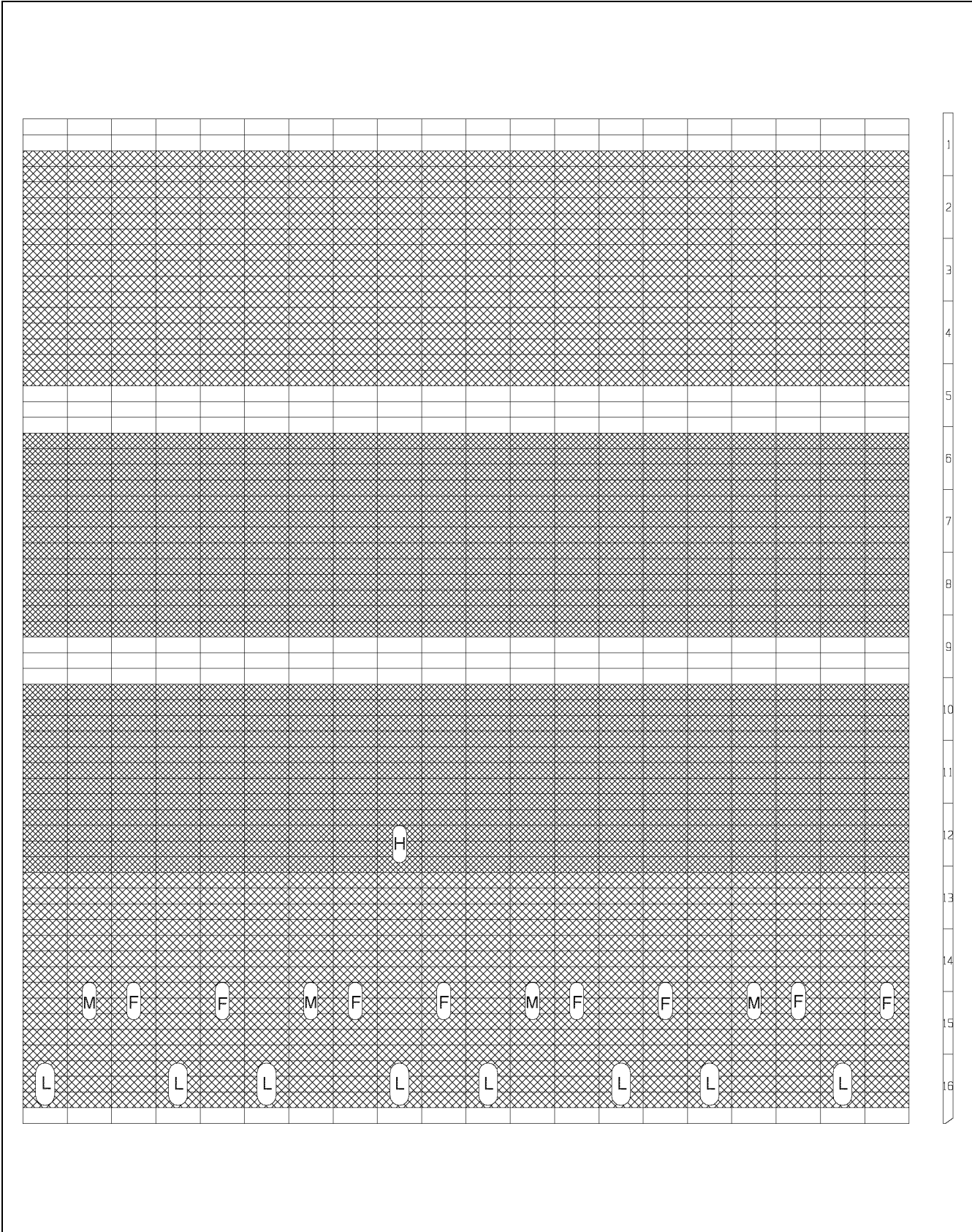

Figure 4N

Wall Sheets Overlap

Throughout Dryer

Wall sheets are installed in overlapping rings around dryer, starting at dryer top and working down. Each ring of sheets vertically overlaps the ring of sheets above it so that grain does not lodge between. Each sheet installed horizontally overlaps the previous sheet in the ring. In *Figure 4P*, sheet (B) laps sheet (1A), (C) laps (B), and so on around the dryer. Each ring of sheets is installed to lap over previous ring sheets already installed above it on dryer: (2) laps (1A), (3) laps (2), and on down dryer.

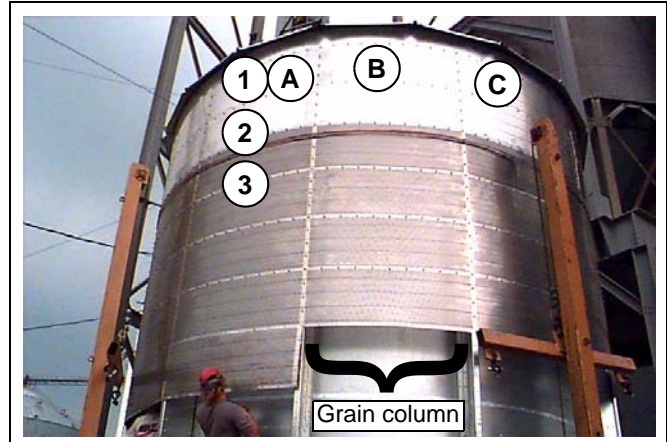

Figure 4O Exterior View

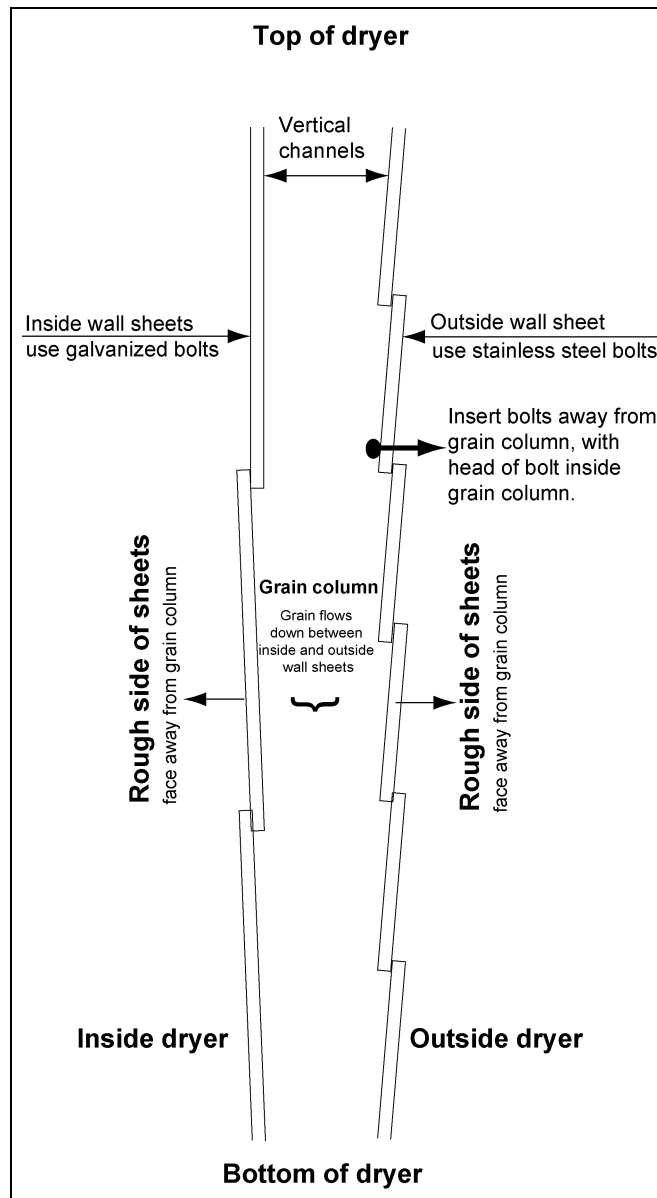

Figure 4P Cross Section

Wall Sheet Comparison



Figure 4Q Inside Wall Sheets - Galvanized

- A. Inside top wall sheet (perforated), 30" high.
Use for inside plenum roof wall.
- B. Inside heat/cool wall sheet (perforated), 40" high.
Use same part to form inside heat wall and inside cool wall.
- C. Inside bottom wall sheet, solid, 15-1/2" high.

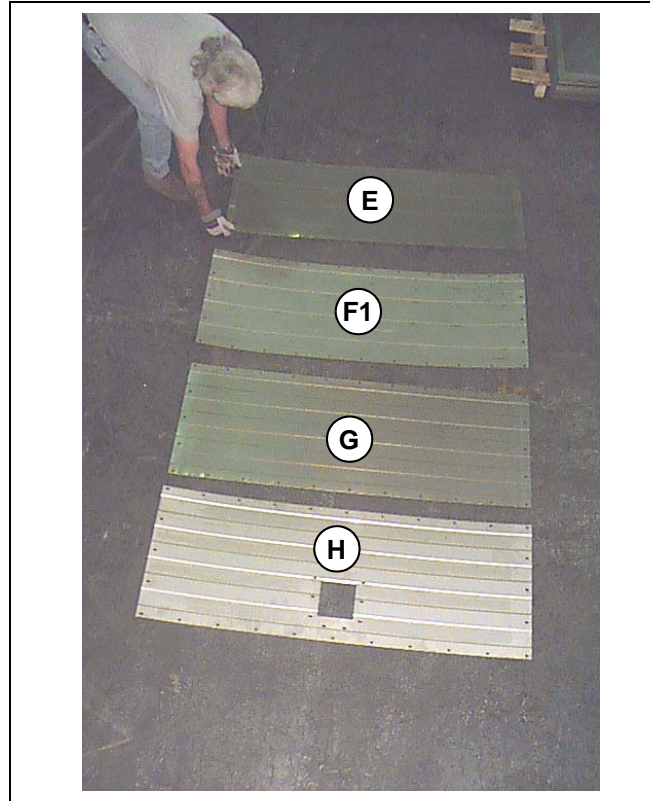

Figure 4R Outside Wall Sheets - Stainless Steel

- E. Outside wall sheet, perforated, 20" high 0.078" (big hole).
- F1. Outside wall sheet, solid, 20" high.
Use for first three (3) rows of wall of outside tower roof and rows where grain turners are installed.
- F2. Outside wall sheet, solid, 20" high (with two (2) slide gate cut outs) - Not shown.
- G. Outside wall sheet, perforated, 20" high. 0.0625" (little hole).
- H. Outside bottom wall sheet, solid, 20" high.
(with slide gate cut outs for base of dryer emergency discharge.)

To minimize the release of fine debris from dryer, install sheets as follows. Install 0.078" perforated sheets down to grain turners. After grain is turned, install 0.0625" perforated sheets. Install solid sheets at grain turners, and at top and bottom of grain columns.

4. Orientation Wall Sheets and Vertical Channels

Wall Sheet Guidelines

Inside wall sheets (and hardware) are galvanized, and form plenum chamber wall of dryer.

Outside wall sheets (and hardware) are stainless steel, and form tower wall of dryer.

These two (2) walls of the dryer are separated by columns of vertical channels. This structure forms grain columns through which grain flows.

Each perforated wall sheet has a rough side and a smooth side. Install wall sheets so the rough side is away from grain column. This reduces grain sticking to wall sheets and allows grain to flow freely down grain column. (*See Figure 4P on Page 36*, wall sheets overlap.)

Install wall sheets to vertical channels so wall sheets overlap as explained in *Figure 4P on Page 36*.

Plan ahead and leave out a vertical channel and some wall sheets where necessary to bring burner, reducer, and blowers into dryer. (Install rolled plenum channels temporarily as required to maintain shape and stability.)

Bolts: In each section of dryer, loosely install all bolts to wall sheets and common bolts through rolled plenum channels reinforcing wall sheets before tightening bolts in that section of dryer.

Insert bolts so that bolt head is in the grain column. This reduces collection of fines (fine debris from grain), and allows grain to flow freely. (*See Figure 4P on Page 36*.)

Do not fill bottom bolt holes in ring of wall sheets. Install next ring of wall sheets with common bolts in bottom bolt holes in previous wall sheets.

Leave out some bolts for lifting brackets.

On vertical wall sheet seams, (plumb, up and down), use 5/16" x 1" hex head bolts and nuts.

On horizontal wall sheet seams, (level, left and right), use 5/16" x 3/4" hex head bolts and nuts.

Use washers where there is a possibility of leaking.

To tighten bolts, work around the ring of wall sheets, tightening horizontal seams, then vertical seams.

To avoid wrinkling wall sheets when tightening bolts, work in pairs. One (1) person (standing in grain column) holds alignment punches in top and bottom holes of wall sheets to align them to vertical channel holes. Second person (standing outside grain column) tightens each nut with impact wrench. Drill out misaligned stainless steel wall sheets. While one (1) worker is tightening horizontal bolts on outside sheets, second worker (inside grain column) presses outside sheets outward.

When installing wall sheets, install support clips to them for parts such as catwalks, platforms, bracing, etc.

Rolled Plenum Channels

Rolled plenum channels are spliced with plenum channel splices, and installed in rings to inside wall sheets. Install 20" apart, and down length of dryer. If necessary to clear another part, shift a rolled plenum channel ring up or down 5" (10" maximum).

Splice to rolled plenum channel, use 5/16" x 1" whiz bolts. Rolled plenum channel to wall sheet, use 5/16" x 3/4" whiz bolts.

Wall Sheet Attachment Guidelines - All Models

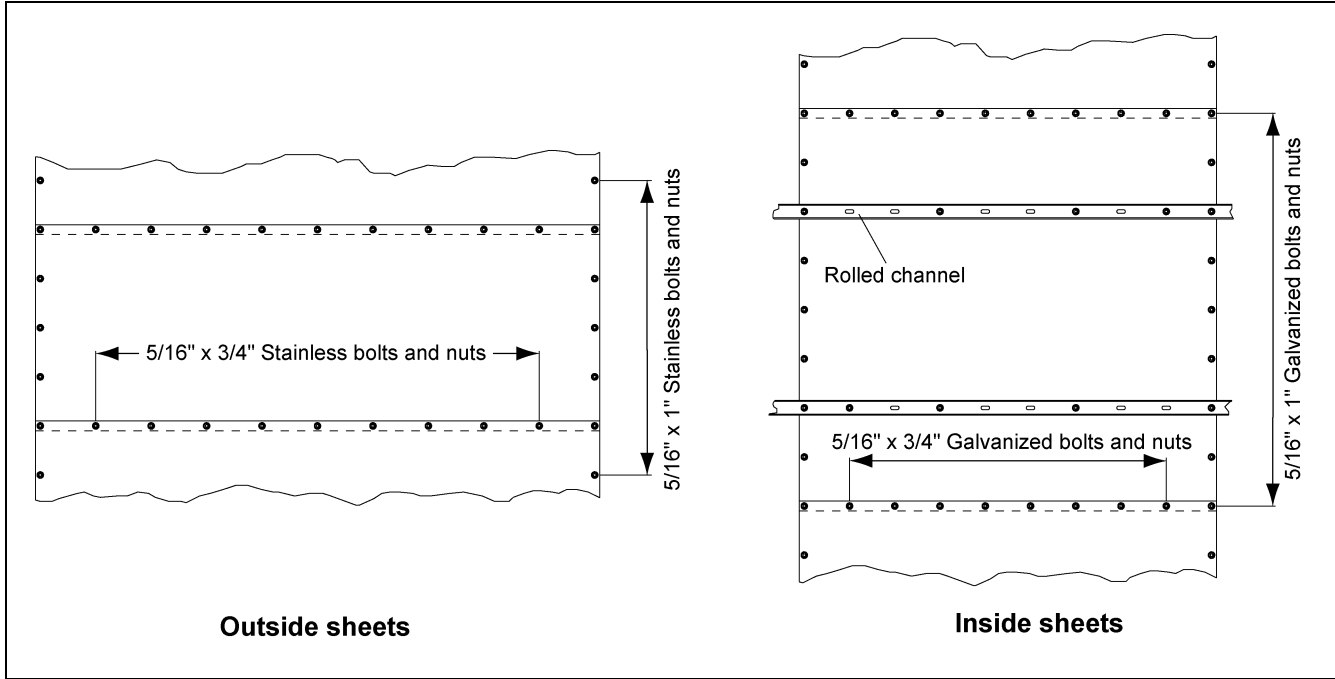

Figure 4S

Inside Wall Sheet Placement - All Models

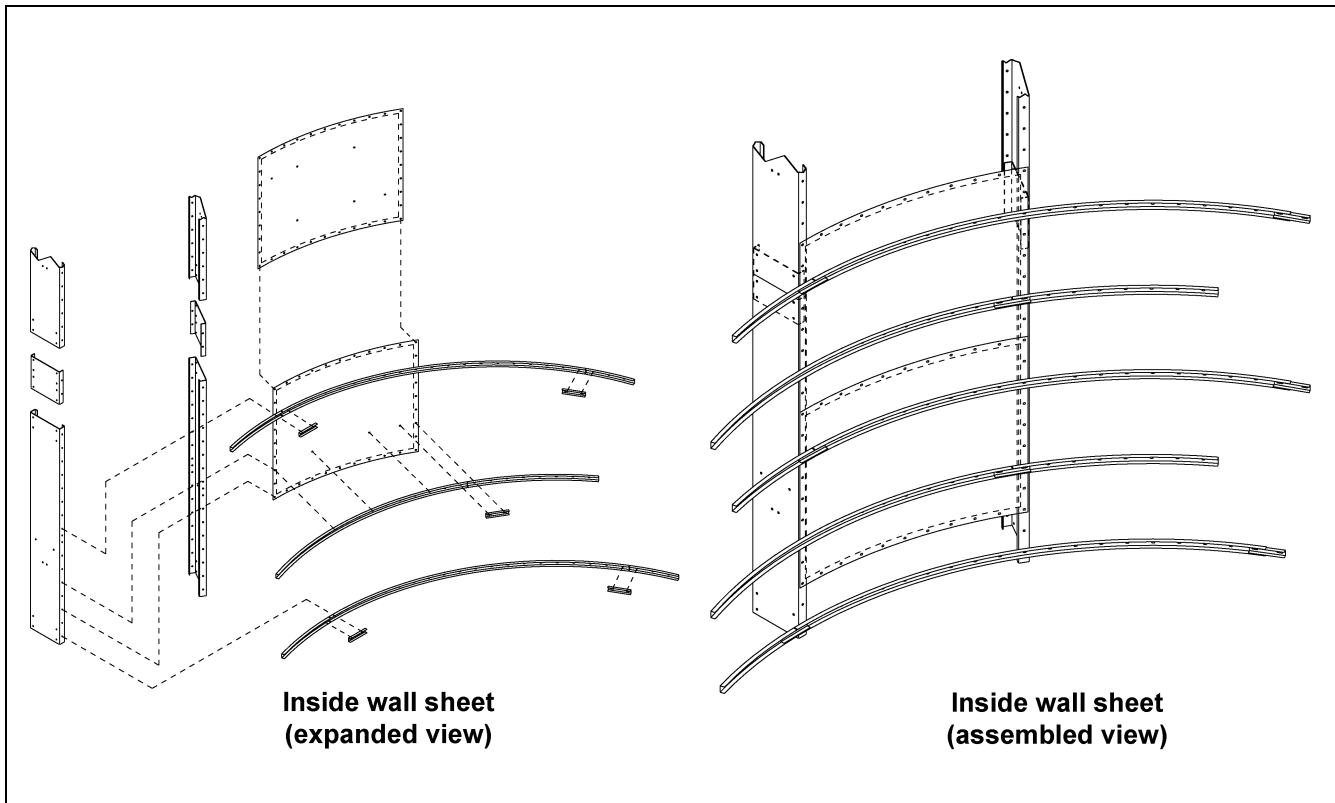

Figure 4T

Outside Wall Sheet Placement - All Models

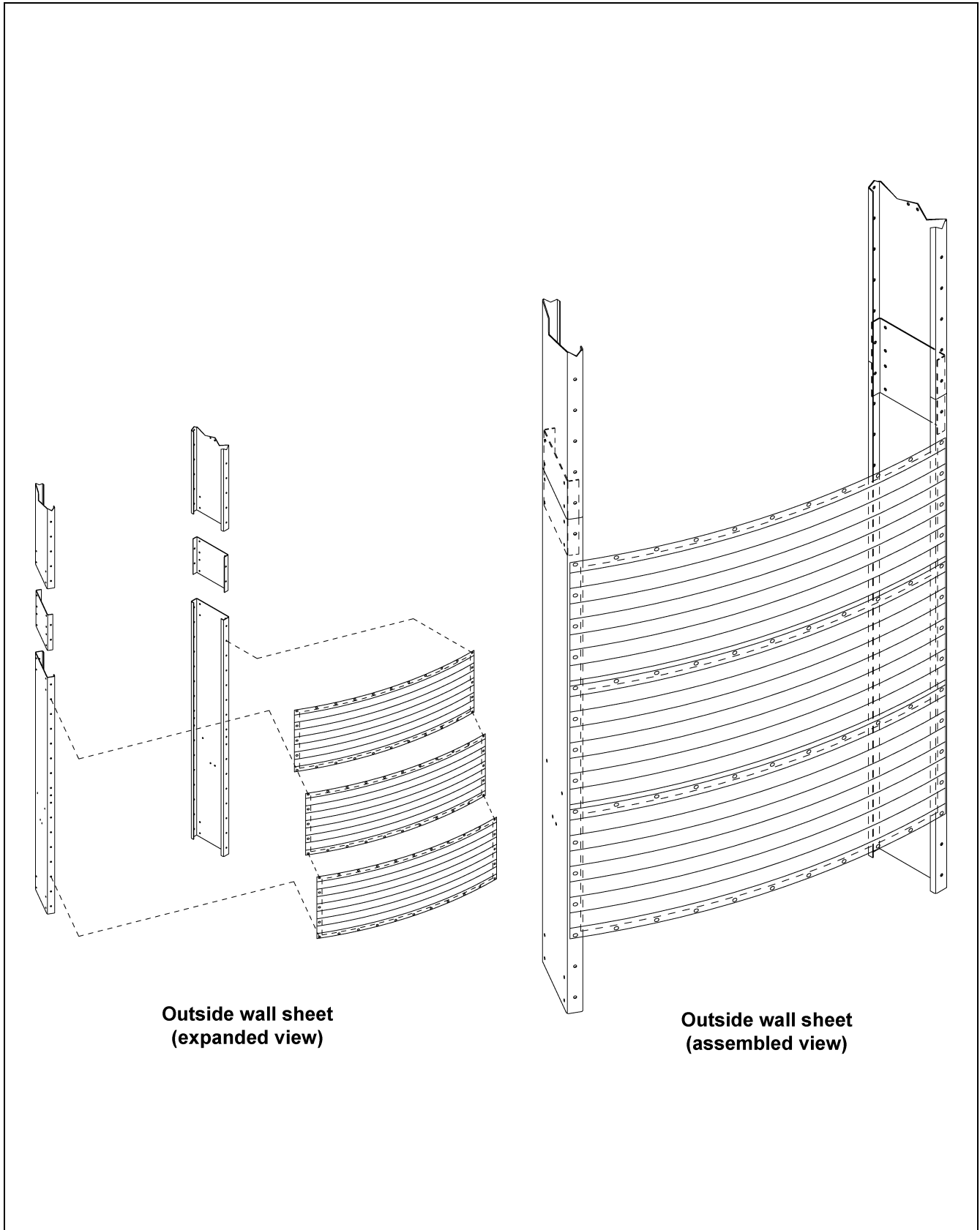

Figure 4U

Example - Installing Wall Sheets to Roof



Figure 4V Hanging inside wall sheets.



Figure 4X Close Up - Installing rolled plenum channels.



Figure 4W Installing rolled plenum channels.

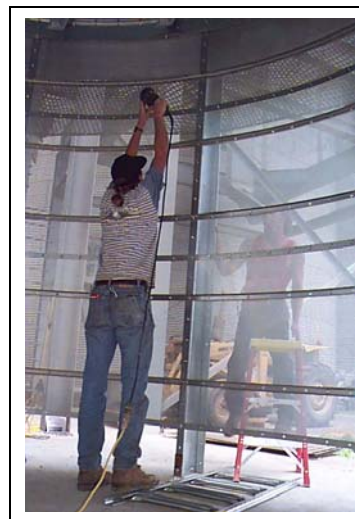

Figure 4Y Tightening inside wall sheets.



Figure 4Z Installing lift brackets to outside wall sheets of tower roof. (With 3/8" x 1" galvanized bolts and nuts.)

4. Orientation Wall Sheets and Vertical Channels

Lifting Dryer Guidelines

Tower dryer is built from roof down, rather than from the ground up. Dryer is lifted to install each set of vertical channels and other components. From below dryer roof to hopper, each lift will have two (2) rows of inside wall sheets and four (4) rows of outside wall sheets installed to each set of vertical channels.

Customarily, jacks are used to lift dryer during construction. Eight (8) 10000 pound, 14' tall lift jacks with hoisting tackle should be sufficient.

Place jacks 11-1/2" to 12" from dryer wall. Place first jack on L.H. side of outside ladder (safety cage may obstruct R.H. side). Space remaining jacks equally around dryer so that each jack will lift approximately the same share of the dryer weight. Center each jack between the two (2) vertical channels it will lift. Level and plumb jacks. Anchor jacks as specified by manufacturer.



Take care during lift of dryer to avoid injury to personnel or damage to dryer and other structures. Do not lift dryer when it is windy enough to shift jacked dryer.

The dryer is heavier with each successive lift. Use a sufficient number of jacks to support the increasing weight of the dryer. Begin with the number of jacks required (usually four (4), six (6) recommended) and add more jacks as dryer weight increases.

Follow jack manufacturer's instructions to attach and operate jacks, and lift dryer. In general, place an even amount of tension on each jack cable so dryer will rise evenly and smoothly. Maintain a smooth, steady motion during the lift to avoid wrinkling wall sheets.

Refer any questions to a qualified rigger.

Lift Bracket Installation

Install two (2) lift brackets to dryer for each jack when bolting on the bottom row of outside wall sheets. From bottom of vertical channel, use bolt holes 3, 4, 5, 6, 7 and 8.

Span two (2) lift brackets with lift bar so jacks do not block vertical rows of bolt holes.

Use 3/8" x 1-1/4" galvanized bolts and nuts.

Initial Lifts

Bolt through vertical channels and outside wall sheets where lift brackets will go with 3/8" x 1", grade 8 bolts. Tighten nuts, then install lift brackets over them. Secure with a second nut.

Blower Lift through Hopper Lift

Bolt lift brackets flat against wall sheets and vertical channels for stability. Install more jacks as necessary.



Sweep any dropped bolts, debris from under dryer after each lift.

Vertical Channel Comparison

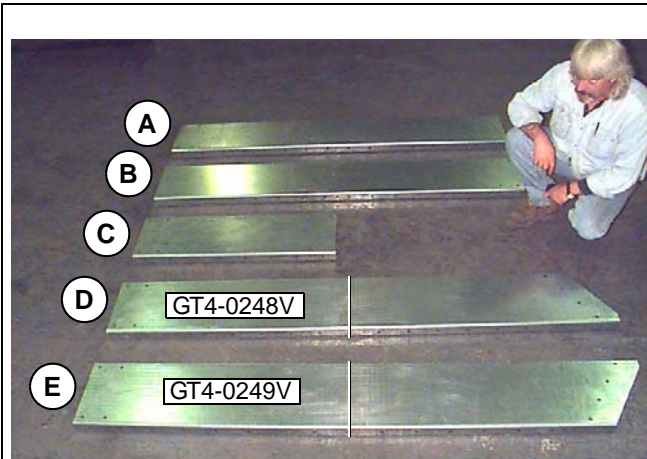

- A. Vertical channel - 80", 10 gauge
- B. Vertical channel - 80", 8 gauge
- C. Vertical channel, 40", 8 gauge
Use as required to fill in vertical channel column.
- D. R.H. Vertical base channel, 88-1/2", installed at base of dryer.
- E. L.H. Vertical base channel, 88-1/2", installed at base of dryer.

Figure 4AA Vertical Channels

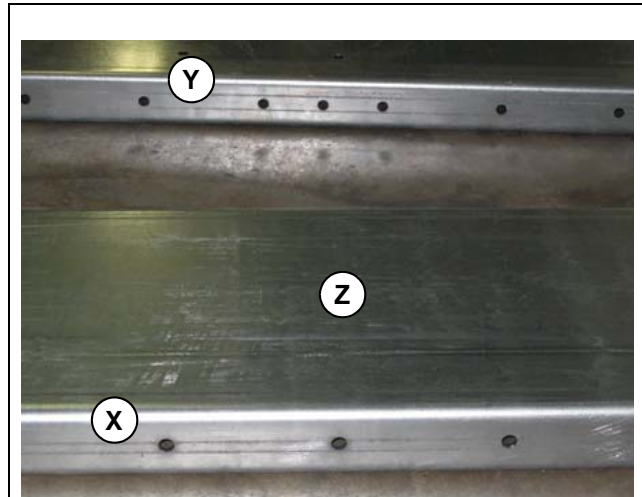

- X. Vertical channel - 80", 8 gauge (bolt holes in side are evenly spaced.)
- Y. Vertical channel - 80", 10 gauge (three (3) bolt holes in center of side are spaced closely together.)
- Z. On the widest side of all 10 gauge vertical channels there are two (2) sets of bolt holes which are only used to install the grain turners.

Figure 4AB Close Up - Vertical Channels

Vertical Channels

10 Gauge vertical channels (lighter) generally installed from roof down to blower level.

8 Gauge vertical channels (heavier) installed from blower level down.

Larger dryers change gauge higher up.

Vertical base channels installed at base of dryer.

Column Layout

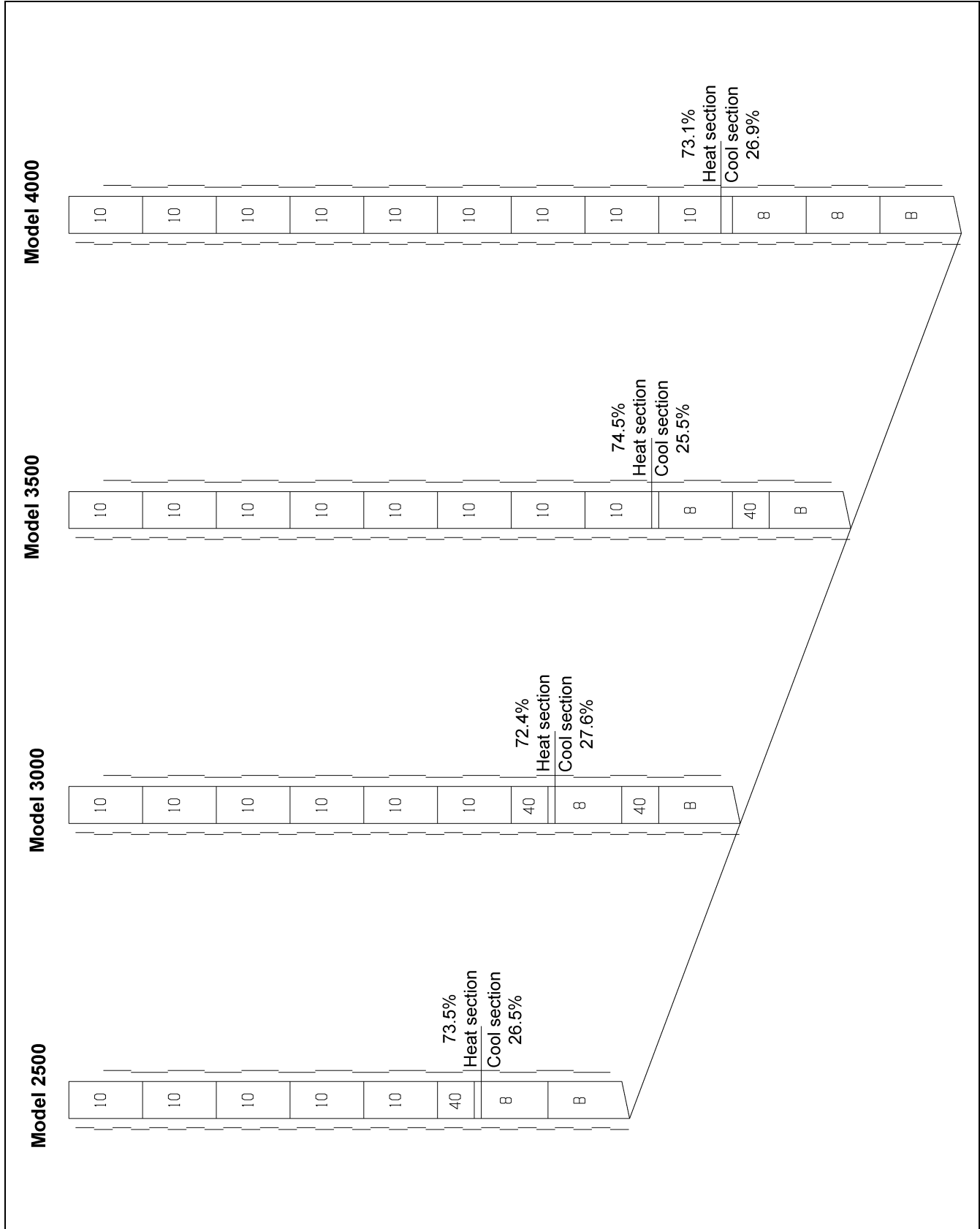

Figure 4AC

Component Placement - All Models

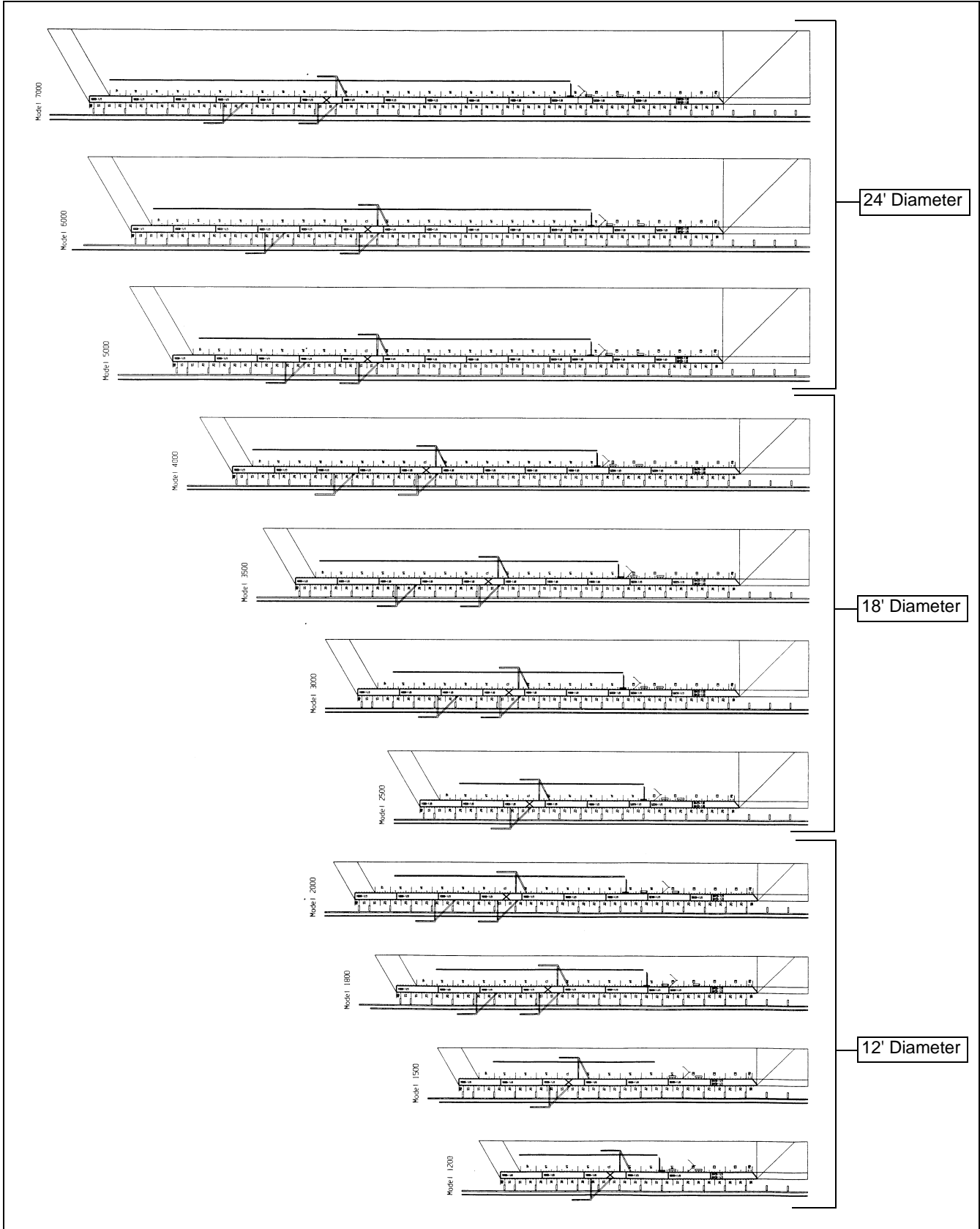

Figure 4AD

Plenum Roof Components (Expanded View)

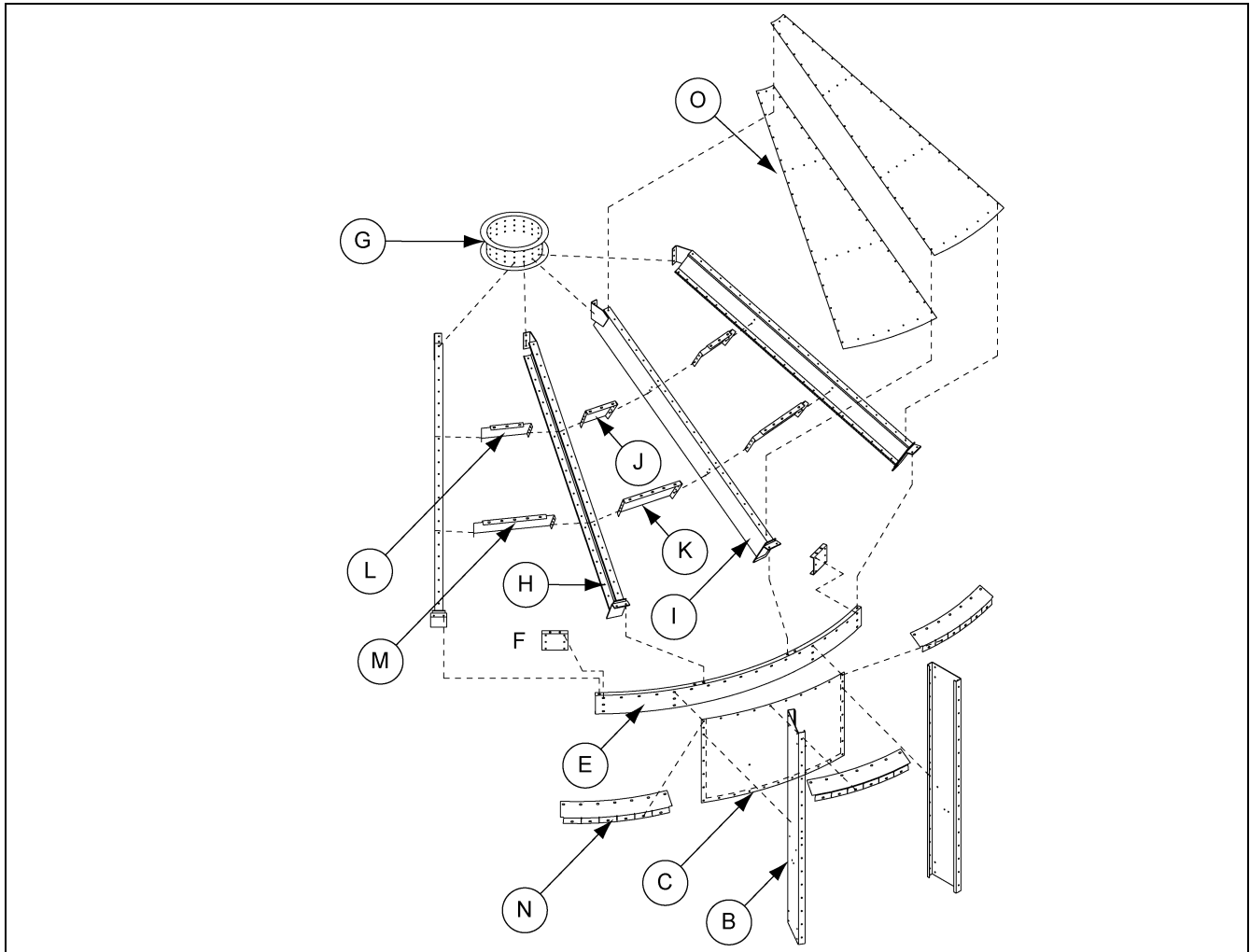

Figure 5A

Parts in Order of Installation		Qty
A	Jig Clips (not shown)	12
B	Vertical Channels	12
C	Inside Top Wall Sheets	12
D	Rolled Plenum Channels (not shown)	6
E	Plenum Eave Channels	6
F	Plenum Eave Channel Splices	6
G	Plenum Roof Center Collar	1
H	Plenum Roof Rafters (R.H.)	9
I	Plenum Roof Rafters (L.H.)	9
J	Rafter Crossmember - Short Top	9
K	Rafter Crossmember - Short Bottom	9
L	Rafter Crossmember - Long Top	9
M	Rafter Crossmember - Long Bottom	9
N	Plenum Roof Flashing	18
O	Plenum Roof Sheets	18
P	Peak Cap	1

Plenum Roof (Aerial View)

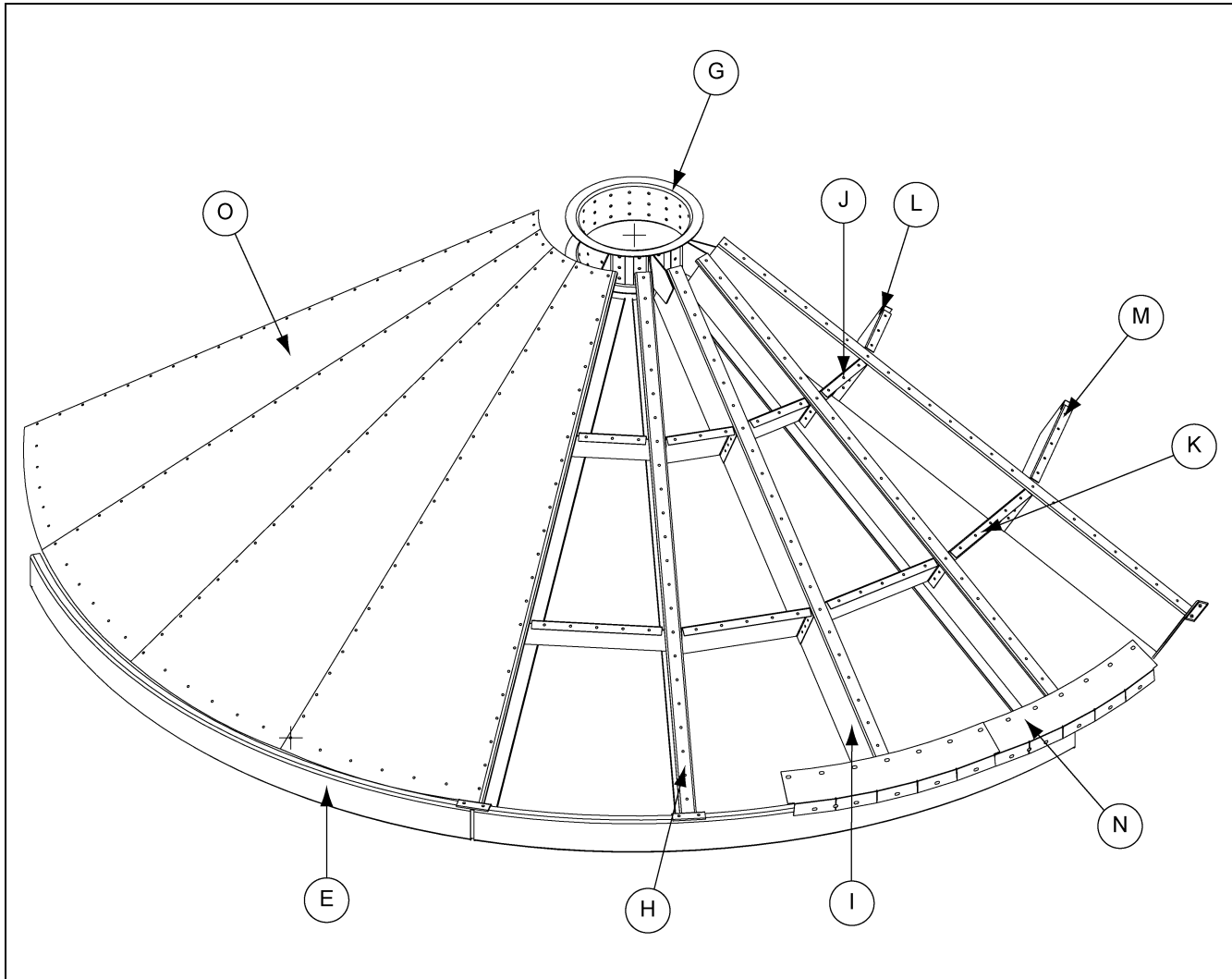

Figure 5B

Parts	
E	Plenum Eave Channels
G	Plenum Roof Center Collar
H	Plenum Roof Rafters (R.H.)
I	Plenum Roof Rafters (L.H.)
J	Rafter Crossmember - Short Top
K	Rafter Crossmember - Short Bottom
L	Rafter Crossmember - Long Top
M	Rafter Crossmember - Long Bottom
N	Plenum Roof Flashing
O	Plenum Roof Sheets

NOTE: Plenum eave channel splice is not shown.

Plenum Roof (Cross Section)

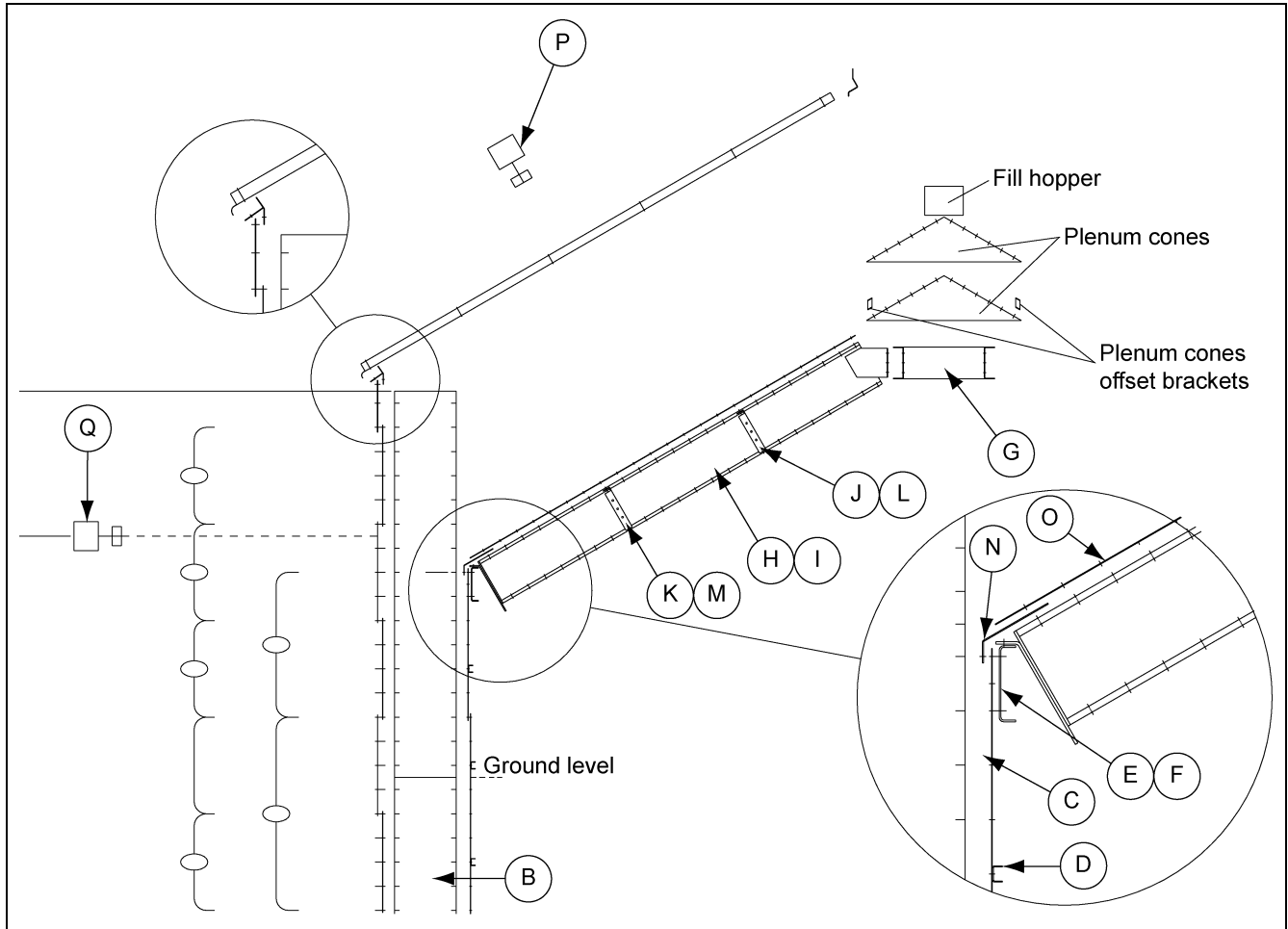

Figure 5C

Parts	
B	Vertical Channels
C	Inside Top Wall Sheets
D	Rolled Plenum Channels
E	Plenum Eave Channels
F	Plenum Eave Channel Splices (not shown)
G	Plenum Roof Center Collar
H	Plenum Roof Rafters (R.H.)
I	Plenum Roof Rafters (L.H.)
J	Rafter Crossmember - Short Top
K	Rafter Crossmember - Short Bottom
L	Rafter Crossmember - Long Top
M	Rafter Crossmember - Long Bottom
N	Plenum Roof Flashing
O	Plenum Roof Sheets
P	Bindicator (RA-6) (As Per Application)
Q	Bindicator (RA-4) (As Per Application)

Jig Clip and Vertical Channel Placement (All Models)

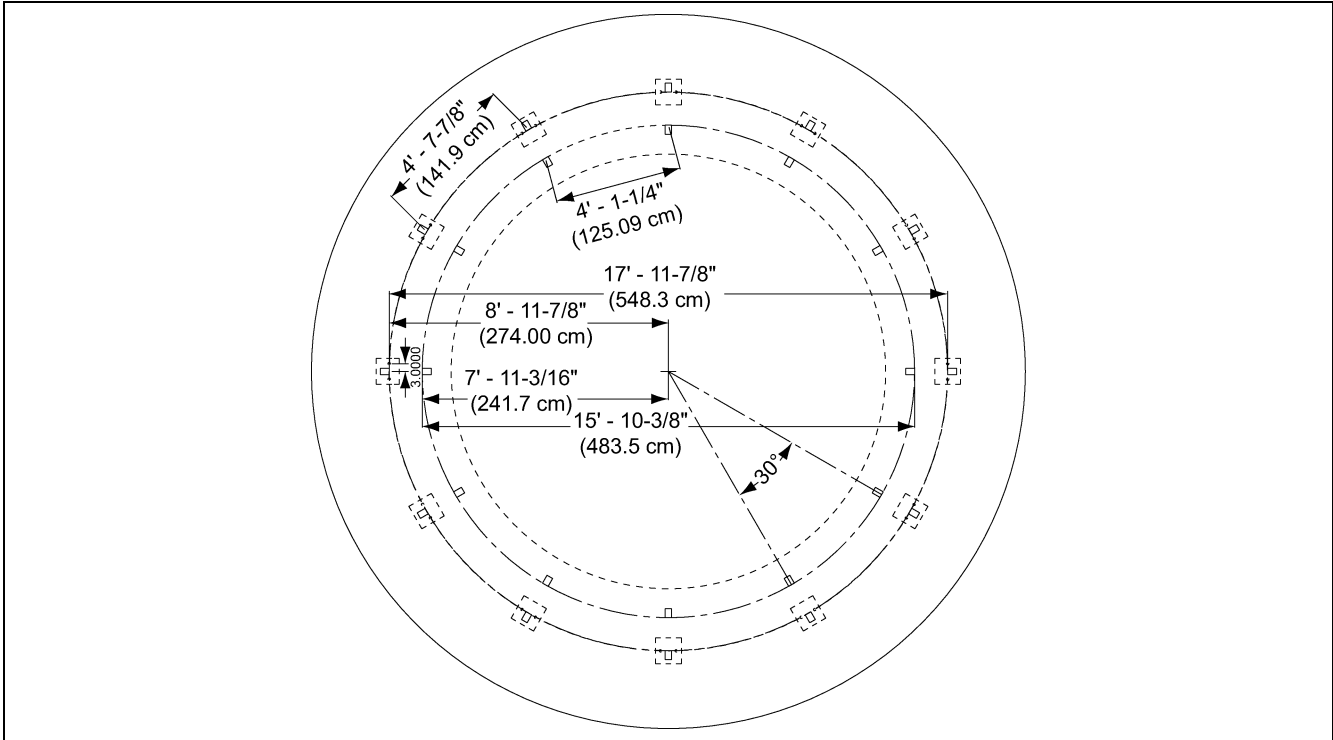

Figure 5D

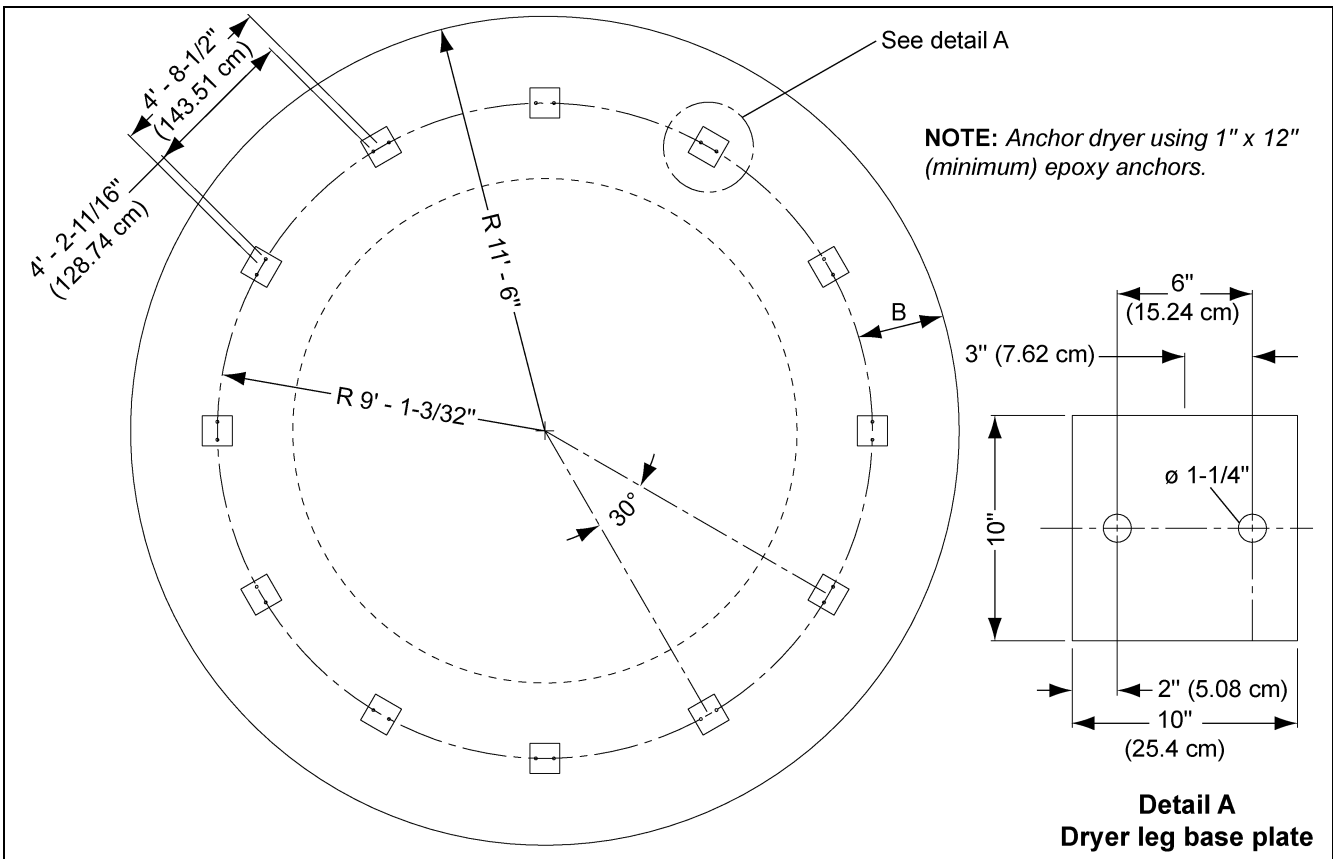

Figure 5E

5. Plenum Roof

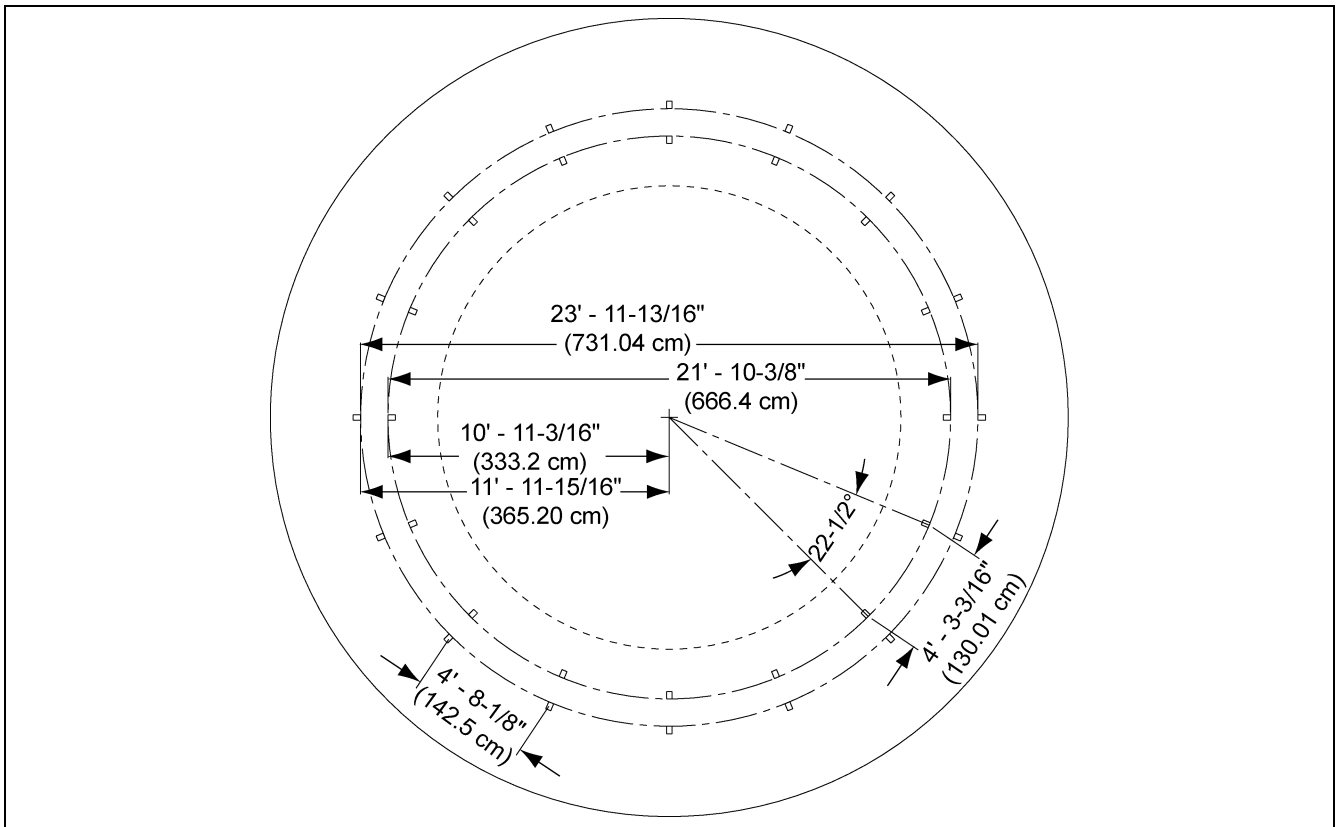

Figure 5F

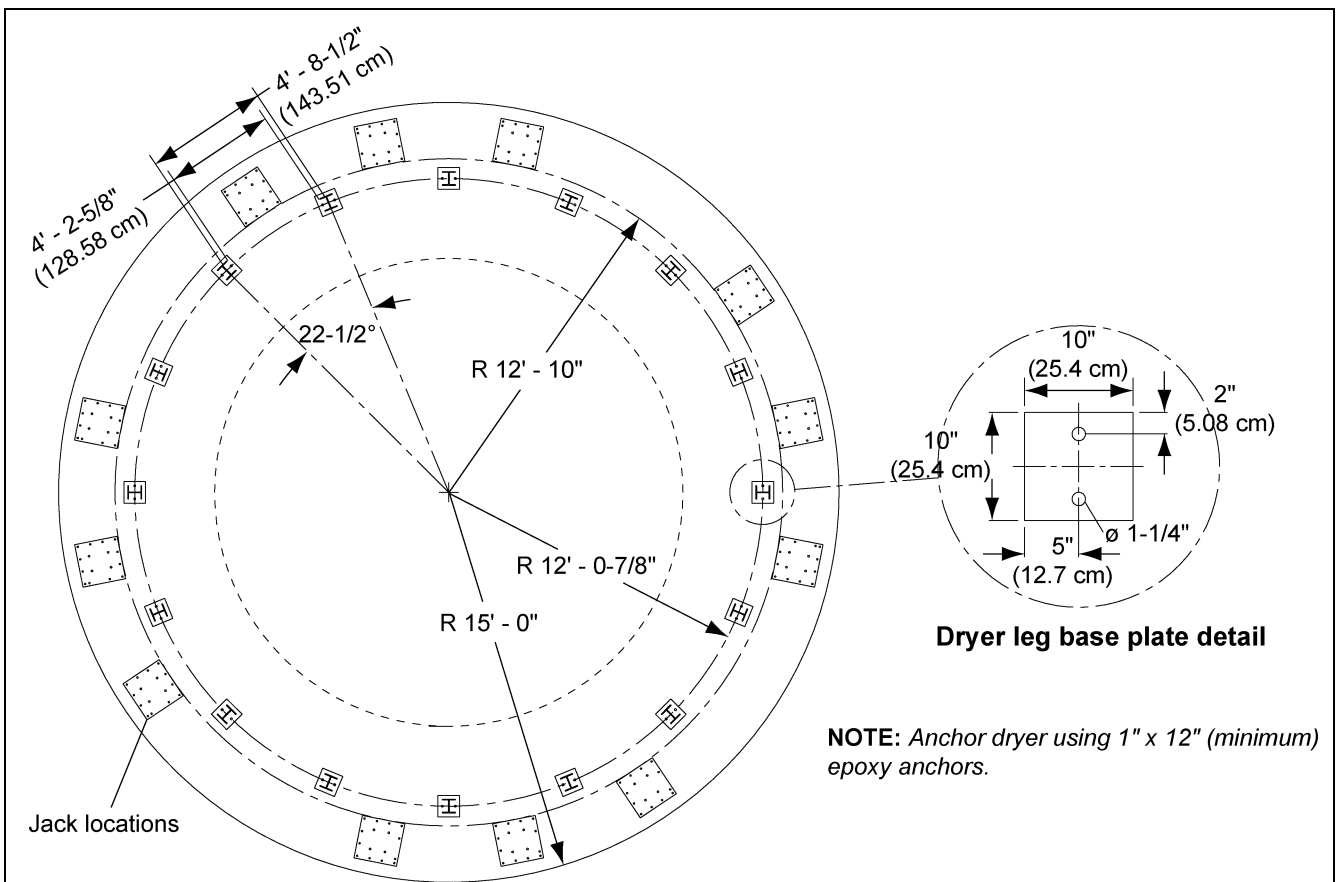

Figure 5G

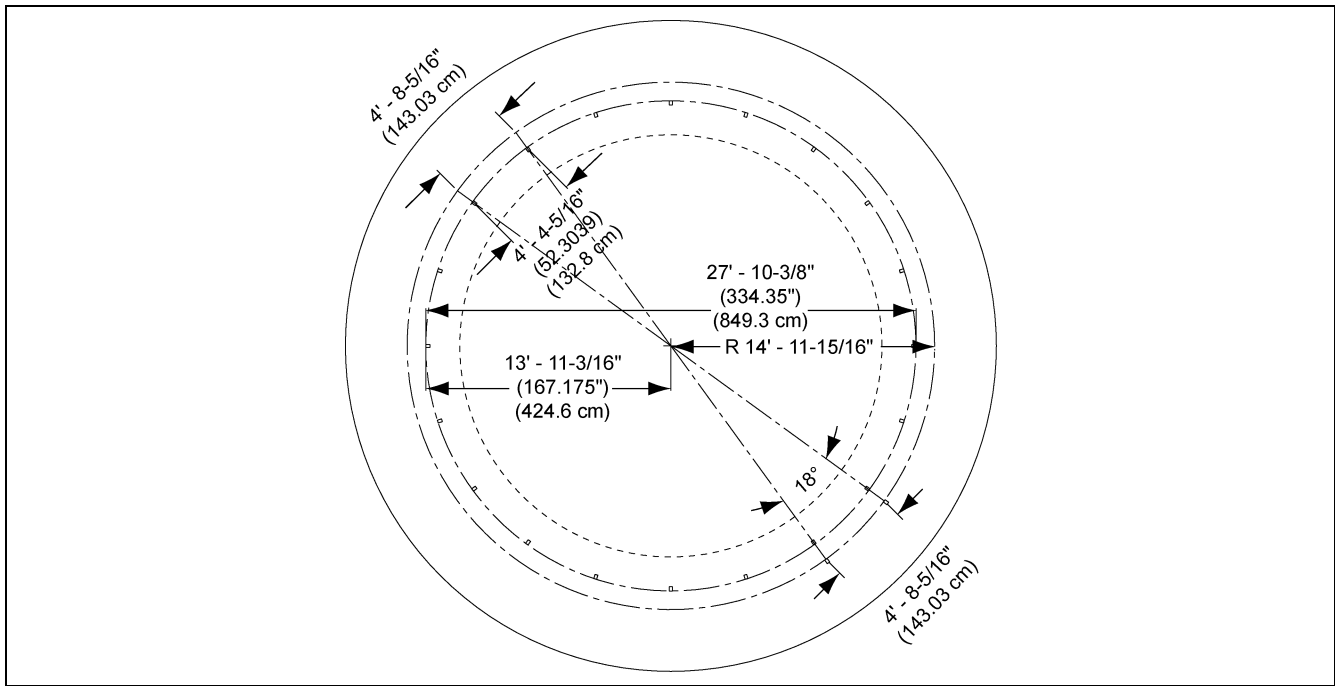

Figure 5H

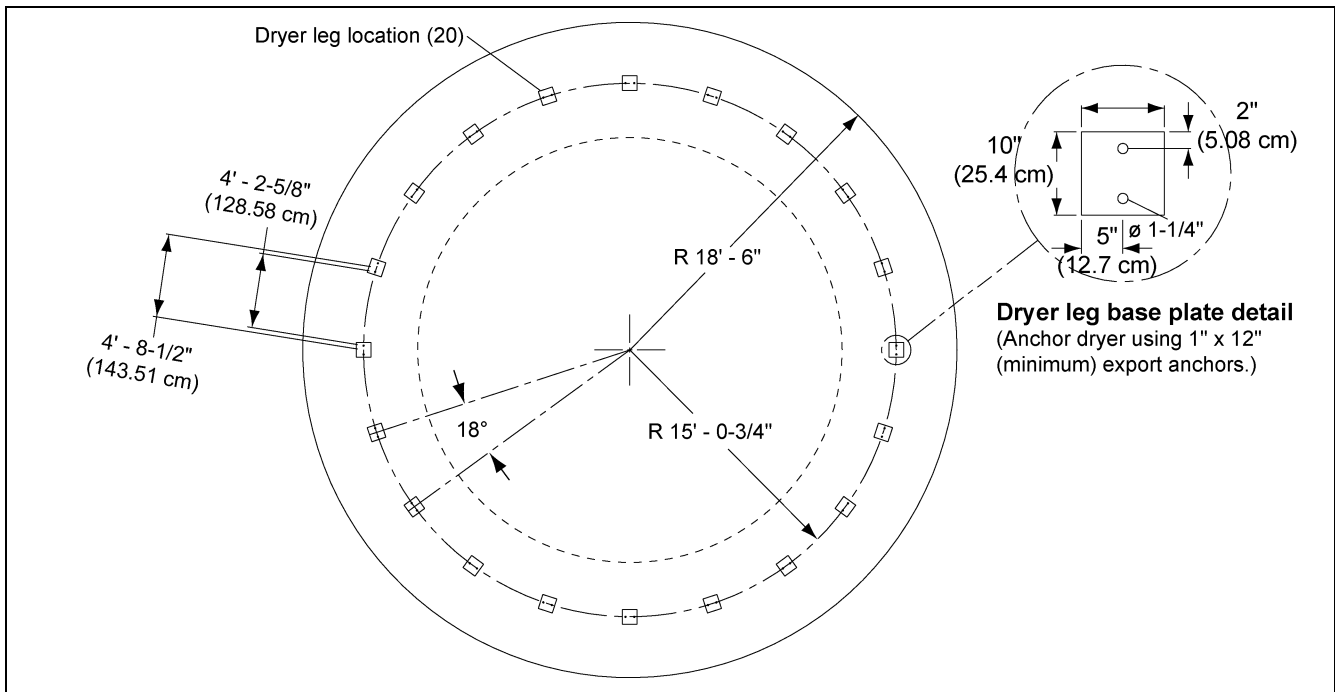

Figure 5I

Key		A = Center of foundation, (marks center of dryer)
□	= Jig clips install to foundation at intervals of 4' 1-1/4" around circle A.	B = Circle drawn for jig chip installation radius is 7' 11-3/16" (marks inside wall of dryer)
[= Vertical channels are bolted to jig clips.	C = Dryer perimeter (marks outside wall of dryer)
NOTE: Note orientation of vertical channels. Each vertical channel mirrors the previous one.		D = Foundation perimeter minimum required is 23' diameter

5. Plenum Roof



Important Safety Precautions:

Dryer has sharp edges. These sharp edges may cause serious injury. Use appropriate personal protective equipment. Use proper lifting techniques.

See [Orientation Section on Page 19](#) for dryer dimensions, components, wall sheet guidelines, etc.
See [Appendix A on Page 435](#) for tools and equipment, [Appendix B on Page 437](#) for hardware, etc.

Steps to Construct Plenum Roof

Jig Clips

Install jig clips as follows.

NOTE: See [Figure 5D-5I on Page 49](#), jig clip and vertical channel placement.

1. Mark center of concrete foundation. This will be dryer center.

Be sure foundation is level.

NOTE: Foundation must be level, with no low or high spots. Jig clips anchor columns of vertical channels to the foundation while the dryer is being constructed. Low or high spots can cause misalignment between vertical channels and wall sheets causing the wall sheets to wrinkle.

2. Hold a tape measure on dryer center mark with an alignment punch and stretch tape to a radius of 7' 11-3/16".

Check orientation of dryer to existing equipment, structures, fuel and electric intake. Plan for placement of dryer features per [Orientation Section on Page 19](#).

Check for lateral clearance.

Check to be sure top of completed dryer will have height clearance.

Use marker, alignment punch, or nail to draw circle on foundation. This is circle B in [Figure 5D on Page 49](#), which is the circle drawn for jig clip installation.

3. Mark the first jig clip position on circle B. Be sure that when dryer is complete, grain unload conveyor will center between two (2) dryer legs.

When dryer is complete, a dryer leg will buttress under each column of vertical channels.

4. Mark the remaining jig clip positions at 4' 1-1/4" intervals around circle drawn for jig clip installation.

If last interval is less than, or greater than 4' 1-1/4", adjust until less than 1/4" split error equally between all intervals. If jig clip positions are not accurate, the dryer may not be round, wall sheets may be misaligned, and the divider hopper between heat section and cool section may not fit.

5. Center outside edge of jig clip flush with interval mark. Drill foundation through jig clip and bolt with 1/2" x 5-1/2" heavy duty expanding anchor bolt and washer. ([See Figure 5J and Figure 5K.](#))



Figure 5J 1/2" x 5-1/2" Expanding anchor bolt and washer.

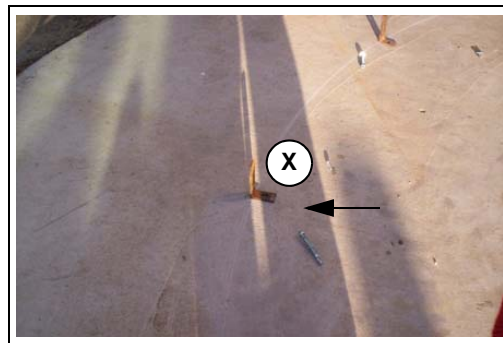

Figure 5K Center outside edge of jig clip flush with interval mark (under X).

Vertical Channels

Bolt 10 gauge vertical channel to each jig clip. Use 3/8" x 1" bolts. Alternate the direction of each vertical channel so that each mirrors the previous one. In other words, bolt vertical channels so they are facing [], then opposing] [, then facing, and so on around perimeter of dryer.

See vertical channel comparison in [Orientation Section on Page 19](#).

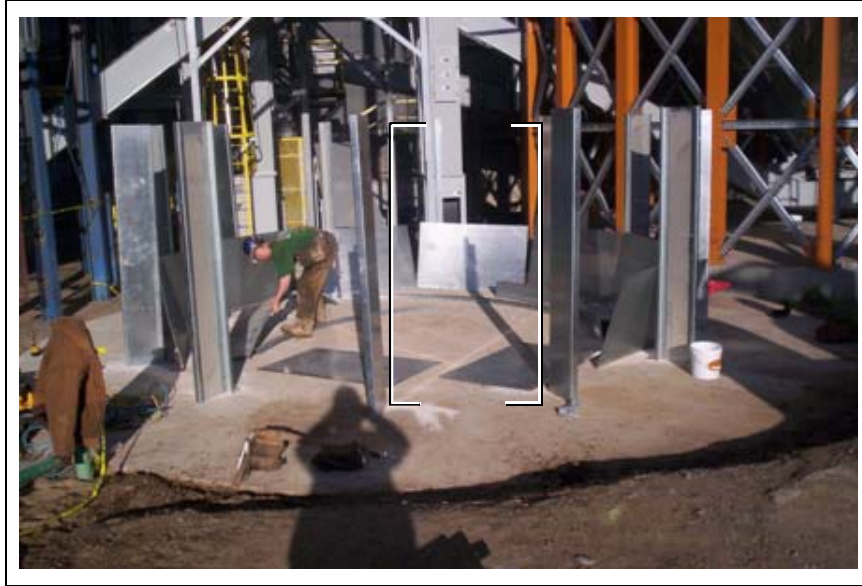

Figure 5L Vertical channels are facing [].

Inside Top Wall Sheets

Install 1 ring of inside top wall sheets around inside of dryer to form inside plenum roof wall as follows.

1. Use inside top wall sheets. See wall sheet comparison in [Orientation Section on Page 19](#) to identify correct wall sheet.
2. Snug bolt perforated inside top wall sheets (30" high) to vertical channels. (Insert bolt toward inside of dryer so that bolt head is in grain column.)

Start inside top wall sheets at bolt hole #3 (BH3 from bottom of vertical channel) but do not fill BH3 because it will be used to install next row of sheets.

Do not fill BH5 from bottom of vertical channel. This is where rolled plenum channel will be installed.

Do not fill 3 closely spaced bolts holes higher up on vertical channel. This is where eave channel will be installed.

NOTE: Do not tighten bolts yet. (Tighten after rolled plenum channels are installed.)

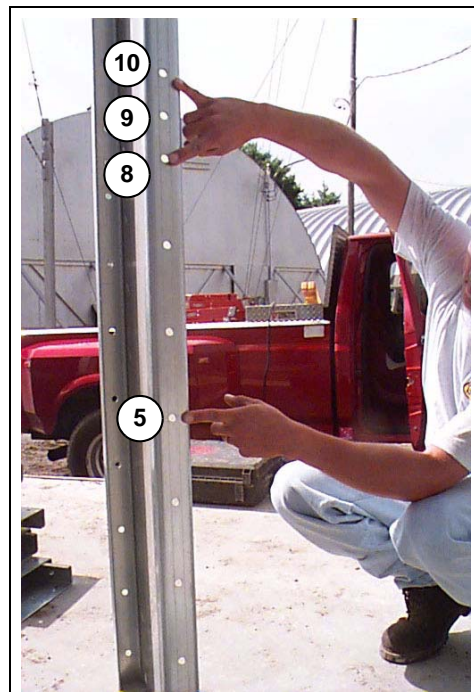

Figure 5M Do not fill bolt hole 5 (from bottom of vertical channel.) and three (3) closely spaced bolts holes above, BH8, BH9 and BH10. (BH-Bolt Hole)

5. Plenum Roof



Figure 5N

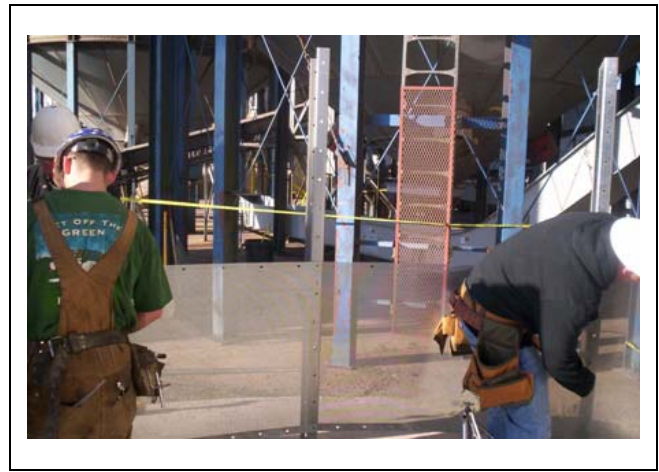

Figure 5O

Rolled Plenum Channels

Install 1 ring of rolled plenum channels to reinforce the ring of inside top wall sheets as follows.

1. Bolt one (1) plenum channel splice to each rolled plenum channel with 5/16" x 1" whiz bolt and nut before installing to dryer.



Figure 5P Plenum Channel Splice



Figure 5Q Plenum Channel Splices - as shipped.

Throughout Dryer

Install rings of rolled plenum channels to wall sheets so closely that fingers will not fit between them.

2. Snug bolt rolled plenum channels to inside top wall sheets with 5/16" x 3/4" whiz lock bolts and nuts.

NOTE: Bolt in fifth bolt hole from bottom of vertical channel.

If necessary to fit last rolled plenum channel into ring, remove bolts from wall sheets on both sides, pull one (1) bolt out of vertical channel (above or below), bend and push it down into place. (Do not cut it.)

3. Test fit. Install rings of rolled plenum channels to wall sheets so closely that fingers will not fit between them.



Figure 5R *Rolled Plenum Channel*

4. After entire ring of rolled plenum channels is installed to this section of the dryer, tighten bolts. If gap/space is observed between sheet and channel (post tightening) drill holes and use 5/16" x 3/4" galvanized bolts and nuts to close the space. (This will prevent flexing movement resulting in sheet tears.)



Figure 5S *Installing rolled plenum channel to inside top wall sheets.*



Figure 5T *Plenum channel splice installed.*



Figure 5U *C-Clamp and alignment punches (5/8" and larger).*

Plenum Eave Channels and Plenum Eave Channel Splices

Snug bolt plenum eave channels to vertical channels with two (2) 3/8" x 2" grade 8 hex head bolts and nuts per vertical channel. Insert bolts in two (2) bottom bolt holes of three (3) bolt holes that are spaced closely together. (Plenum roof flashing will be installed in top bolt hole.)

Splice plenum eave channels together with plenum eave channel splices. Use 3/8" x 2" grade 8 hex head bolts and nuts. Plenum eave channel splice is installed on inside of dryer. Insert bolts toward center of dryer, through wall sheet, plenum eave channel, and then plenum eave channel splice.) Use 3/8" galvanized washers are needed. Some drilling may be needed for correct fit to wall sheet.

Tighten ring of plenum eave channels after it is complete.



Figure 5V *Plenum Eave Channel Splice*

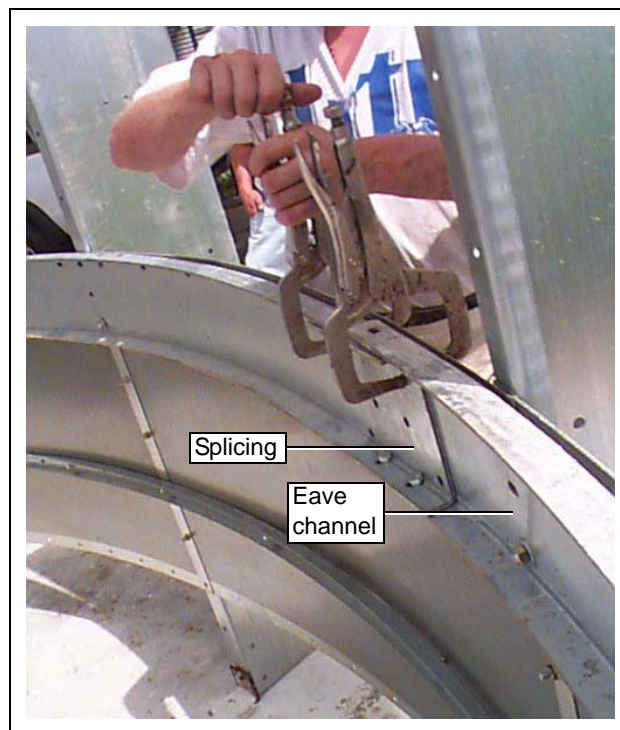

Figure 5W *Splicing Plenum Eave Channels*



Figure 5X Installing eave channels to vertical channels.

Plenum Roof Rafters (Right Hand and Left Hand) and Plenum Roof Center Collar

Install (18 R.H. and L.H.) plenum roof rafters around roof of dryer as follows. (See [Figure 5A on Page 46](#), [Figure 5B on Page 47](#) and [Figure 5C on Page 48](#).) (See [Figure 5AB-Figure 5AI](#).)

1. From opposite sides of dryer, bring a pair of plenum roof rafters together to plenum roof center collar in center of dryer. Orient to bolt holes in plenum roof center collar as shown in [Figure 5Y](#).

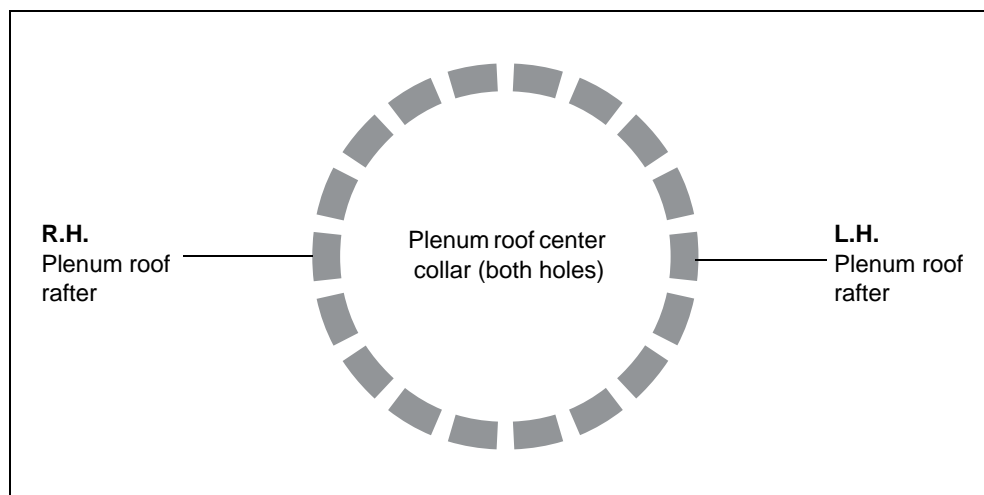

Figure 5Y

5. Plenum Roof

Snug bolt tops of plenum roof rafters to plenum roof center collar. Use 3/8" x 1" hex head galvanized bolts and nuts.

Snug bolt bottoms of plenum roof rafters in pairs of bolt holes along top of eave channel. Use 3/8" x 1-1/4" grade 8 hex head bolts and nuts. (3/8" Galvanized washers as needed.)

2. Snug bolt two (2) more plenum roof rafters to plenum roof center collar. Orient to bolt holes in plenum roof center collar as shown in [Figure 5Z](#).

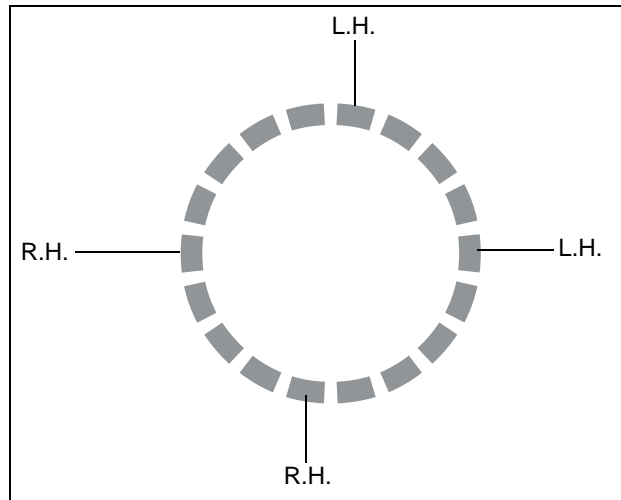

Figure 5Z

3. Install remaining sixteen (16) plenum roof rafters to plenum roof center collar as shown in [Figure 5AA](#).

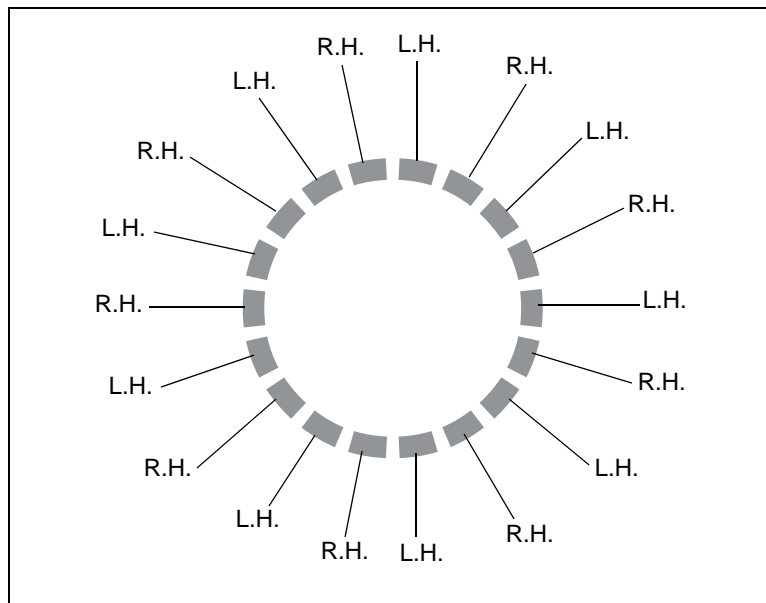

Figure 5AA

4. Level plenum roof center collar.



Figure 5AB *Plenum Roof Center Collar*



Figure 5AD *Top of plenum roof rafters installs to center collar.*

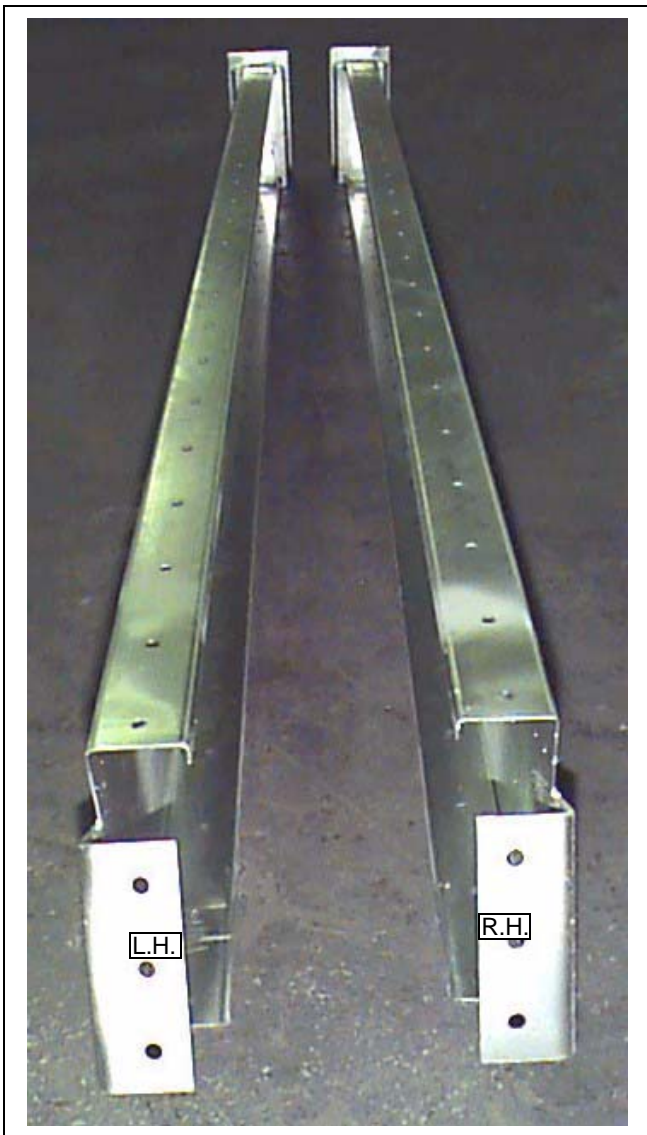

Figure 5AC *A pair of plenum roof rafter are right hand and left hand. R.H. and L.H. mirror each other.*



Figure 5AE *Bottom of plenum roof rafters installs to eave channel.*

5. Plenum Roof



Figure 5AF From opposite sides of dryer, bring a (R.H. and L.H.) pair of plenum roof rafters together in center of dryer.



Figure 5AI Close Up - Bolt top of plenum roof rafters to plenum roof center collar.



Figure 5AG Bring first pair of plenum roof rafters together to plenum roof center collar in center of dryer



Figure 5AJ Close Up - Bolt bottom of plenum roof rafters to top of plenum roof eave channel (in pairs of bolt holes).

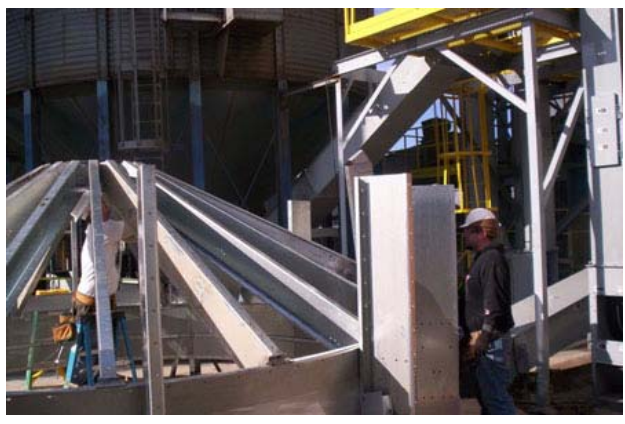

Figure 5AH Bolt first pair of plenum roof rafters to plenum roof center collar in center of dryer.

Rafter Crossmembers

Install rafter crossmembers between plenum roof rafters as illustrated in [Figure 5AL-Figure 5AN](#). Snug bolt with 5/16" x 1" hex head bolts and nuts until all are installed, then tighten.

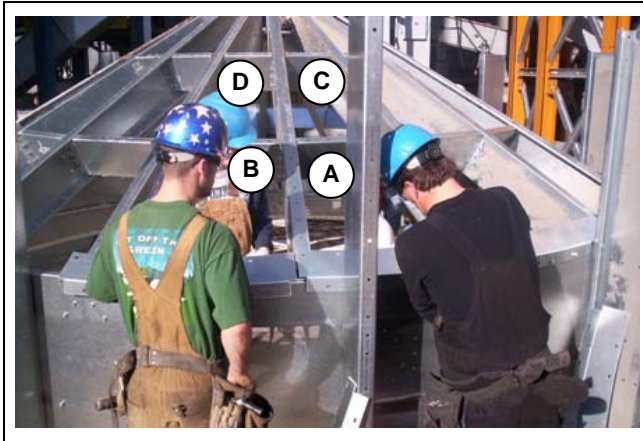

Figure 5AK Install rafter crossmembers as marked.

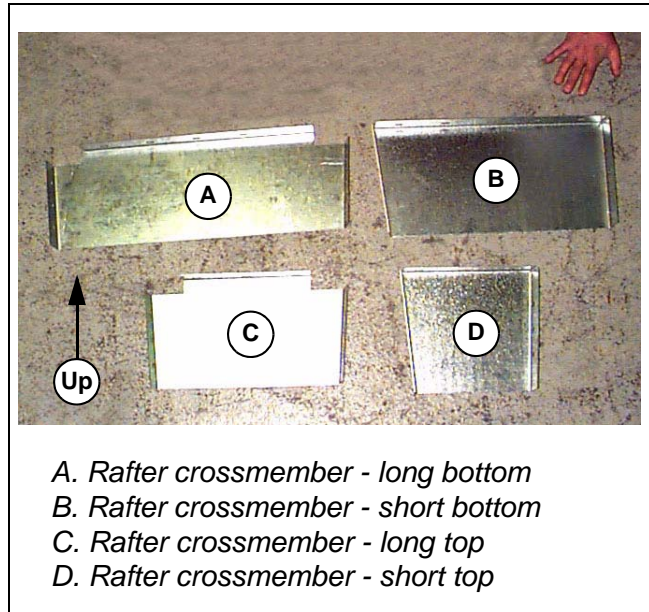

Figure 5AL Facing dryer from the outside, install rafter crossmembers as shown.



Figure 5AM Installing rafter crossmembers.

5. Plenum Roof

Plenum Roof Flashing

Install plenum roof flashing (with tabs down) over inside top plenum wall sheets.

Overlap plenum roof flashing.

Snug bolt with 5/16" x 1" whiz bolts and nuts.

Do not tighten bolts in tabs on flashing until after plenum roof sheets are installed.



Figure 5AN Installing plenum roof flashing with tabs over inside top wall sheets.

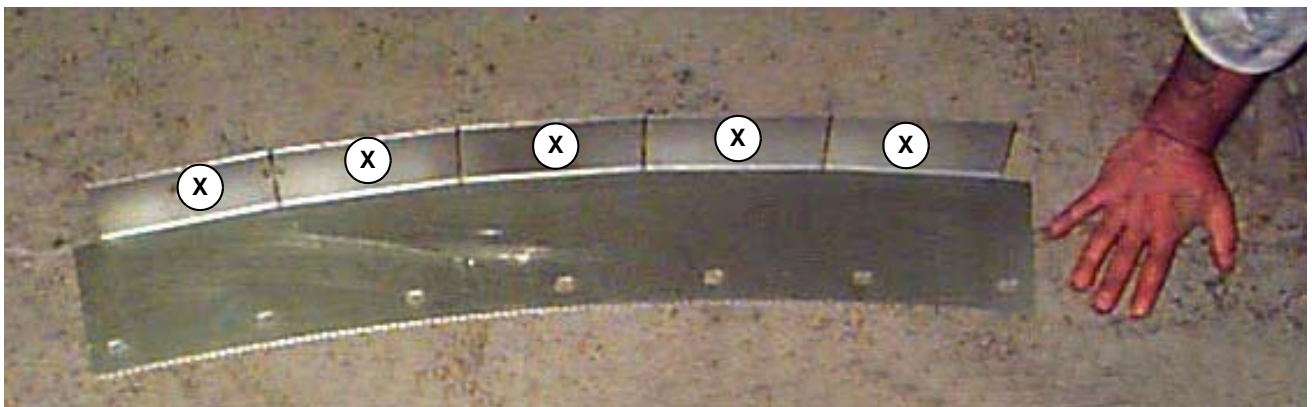

Figure 5AO Tabs on plenum roof flashing are marked by "X".

Plenum Roof Sheets

Bolt plenum roof sheets over plenum roof rafters and over plenum roof flashing as follows.

Use 5/16" x 1" whiz lock galvanized bolts and nuts.

Insert bolts toward inside of dryer.

NOTE: Leave two (2) outside bolt holes on peak of plenum roof sheets open. Peak cap will be installed there. (See Figure 5AQ.)

Overlap plenum roof sheets so that each sheet overlaps previous sheet with common bolts. In other words, if working counterclockwise, left edge of each sheet goes over right edge of previous sheet.

When all plenum roof sheets are in place, tighten bolts. Also tighten bolts on tabs of plenum roof flashing.



Figure 5AP Bolting Plenum Roof Sheets



Figure 5AQ Plenum roof sheet. Do not fill top two (2) outside bolt holes on plenum roof sheets (circled) until peak cap installation.



Figure 5AR *Aligning Plenum Roof Sheets*



Figure 5AS *Plenum roof is ready for peak cap assembly installation.*

Peak Cap and Plenum Roof Center Collar

1. Bolt plenum cone fill hopper over plenum center cone with nine (9) plenum cone offset brackets.

Use 5/16" x 1" whiz lock galvanized bolts and nuts.

2. Center and level peak cap over plenum roof center collar.

3. Bolt peak cap to top of plenum roof sheets.

Use 5/16" x 1" whiz lock galvanized bolts and nuts in two (2) bolt holes on outside of plenum roof sheets.



A. Plenum cone fill hopper
B. Plenum center cone

Figure 5AT Peak cap components (May be pre-assembled in plant.)



Figure 5AU Installing peak cap to plenum roof sheets.



Figure 5AV Close Up - Plenum Cone Offset Bracket

Tighten remaining bolts on plenum roof



Figure 5AW Tightening inside top wall sheets.
(Inspect all when completed. Access is restricted after this point.)



Figure 5AX Hand tightening plenum roof rafters, wall sheets, eave channels, cross members, etc.



Figure 5AY Hand tightening rafter crossmembers.



Figure 5AZ Interior View after lifting dryer -
Completed plenum roof.

Tower Roof (Assembled Over Plenum Roof - Cross Section)

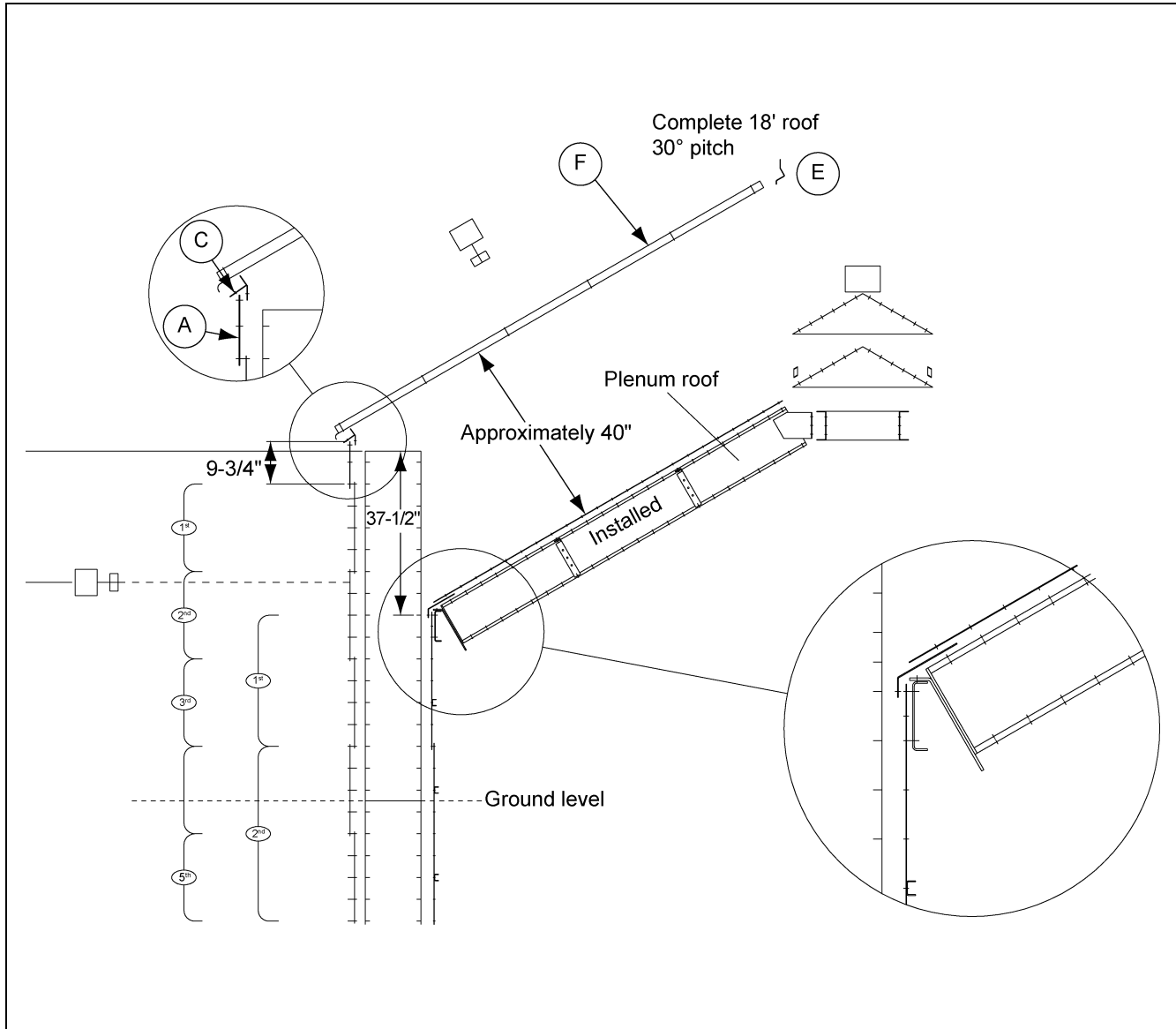

Figure 6A

Parts in Order of Installation		Qty
A	Roof Band Sections	6
B	Roof Seal (not shown)	75'
C	Eave Clips	18
D	Intermediate Eave Clips	18
E	Tower Roof Center Collar Sections	3
F	Tower Roof Sheets	18
G	Roof Rungs	13
H	Expansion Ring Clips (not shown)	18
I	Expansion Ring Sections (not shown)	3
J	Strip Caulking (not shown)	48'
K	Center Collar Flashing Sections	3
L	Fill Tube Weldment	1

Tower Roof (Aerial View)

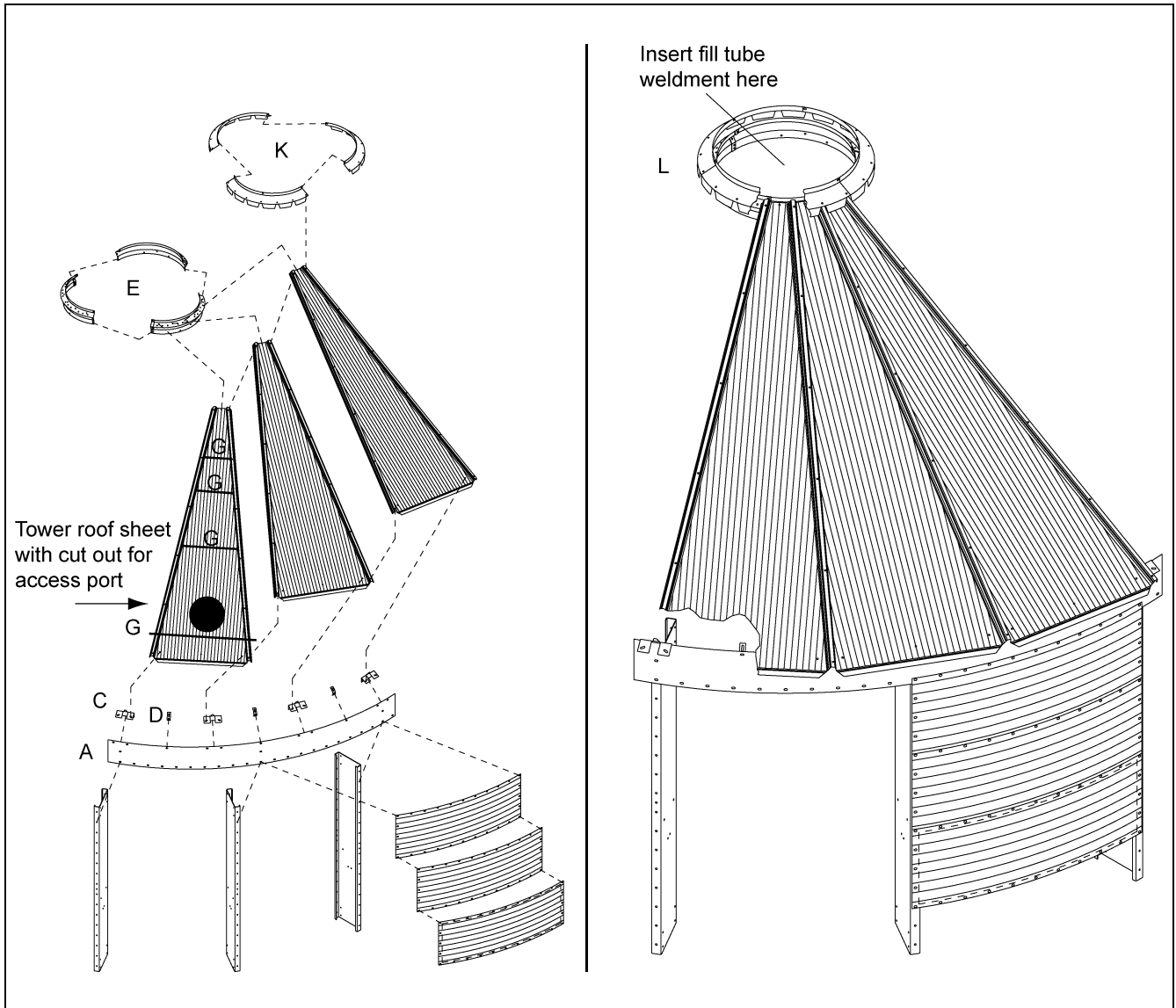

Figure 6B

Parts in Order of Installation		Qty
A	Roof Band Sections	6
B	Roof Seal (not shown)	75'
C	Eave Clips	18
D	Intermediate Eave Clips	18
E	Tower Roof Center Collar Sections	3
F	Tower Roof Sheets	18
G	Roof Rungs	13
H	Expansion Ring Clips (not shown)	18
I	Expansion Ring Sections (not shown)	3
J	Strip Caulking (not shown)	48'
K	Center Collar Flashing Sections	3
L	Fill Tube Weldment	1

Tower Roof Access Port

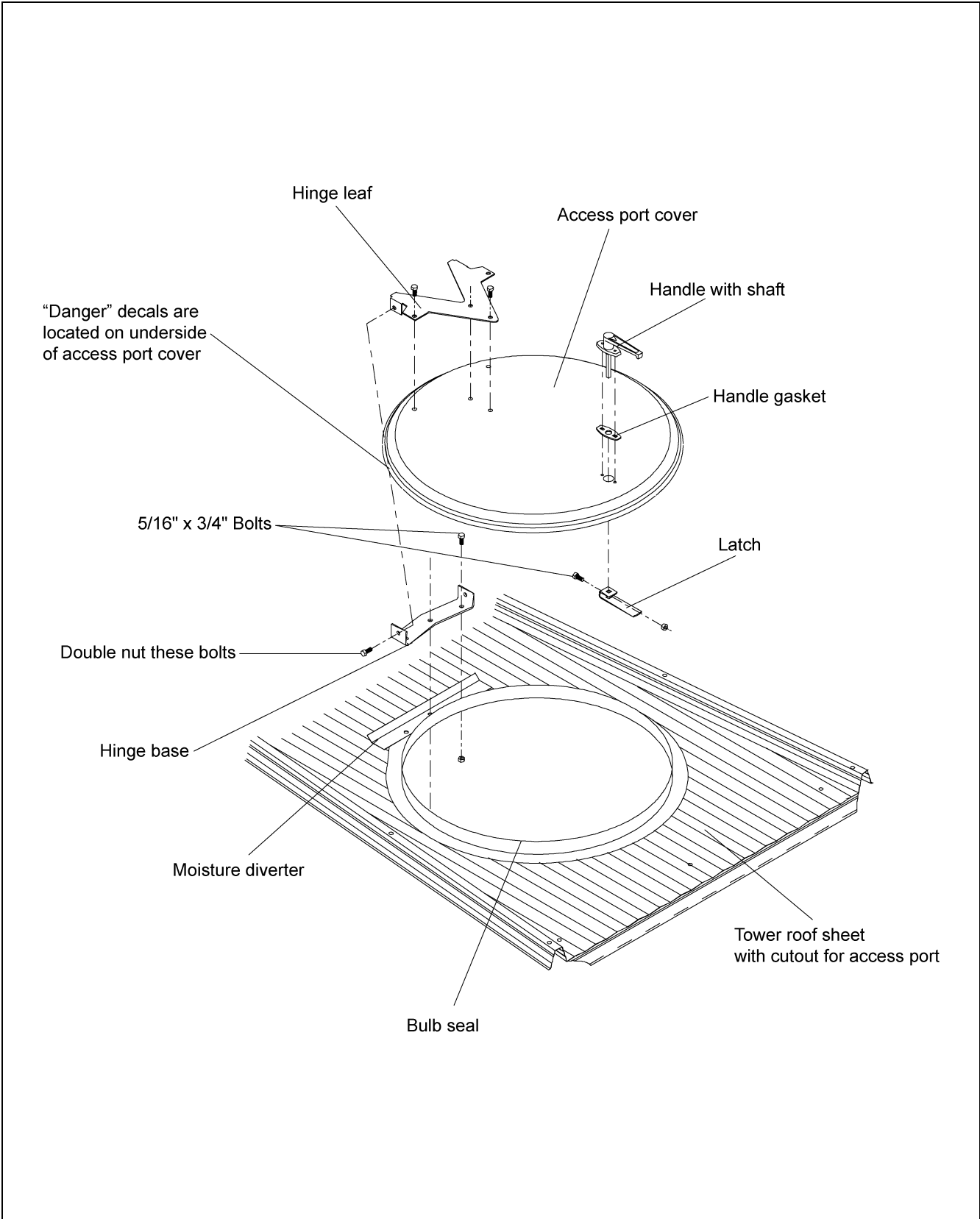

Figure 6C

6. Tower Roof



Important Safety Precautions:

Dryer has sharp edges. These sharp edges may cause serious injury. Use appropriate personal protective equipment. Use proper lifting techniques.

See [Orientation Section on Page 19](#) for dryer dimensions, components, wall sheet guidelines, etc. See [Appendix A on Page 435](#) for tools and equipment, [Appendix B on Page 437](#) for hardware, etc.

Steps to Construct Tower Roof

Roof Band

Use 5/16" x 3/4" stainless steel whiz lock bolts and 5/16" nuts. (Galvanized can be substituted here.)

Install roof band sections so they overlap around outside of dryer. Bolt each roof band section across three (3) vertical channels, in top two (2) bolt holes of each vertical channel.



Figure 6D Roof band section. Top of roof band has pairs of bolt holes alternating with single bolt holes. Bottom of roof band has evenly spaced bolt holes.



Figure 6E Installing roof band sections to overlap around (outside) top of vertical channels.

Bulb Seal

Press continuous strip of bulb seal over top of entire length of roof band.



Figure 6F *Bulb seal as shipped.*



Figure 6G *Pressing bulb seal over top of roof band.*

6. Tower Roof

Eave Clip

Use 5/16" x 3/4" stainless steel whiz lock bolts and 5/16" nuts. (Galvanized could be substituted here.) Snug bolt tabs of eave clips (over roof rubber seal) to outside of roof band. Use pairs of bolt holes at top of roof band.

NOTE: Do not tighten bolts until after expansion ring is loosely installed to tower roof.

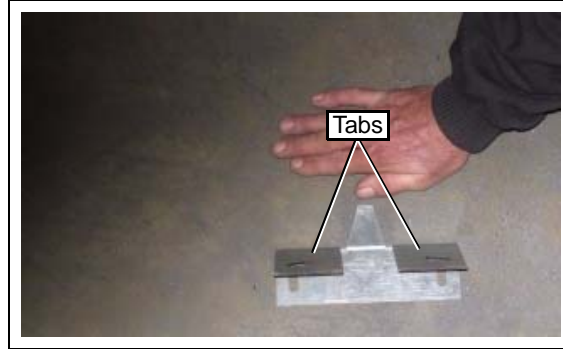

Figure 6H Eave Clip

Intermediate Eave Clip

See [Figure 6A on Page 67](#), [Figure 6B on Page 68](#) and [Figure 6C on Page 69](#).

Use 5/16" x 3/4" stainless steel whiz lock bolts and nuts.

Snug bolt Intermediate eave clips to inside of roof band. Use single holes at top of roof band.

NOTE: Do not tighten bolts until after expansion ring is loosely installed to tower roof.

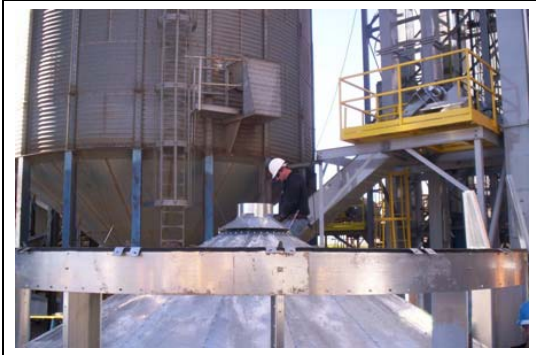

Figure 6I Installing bulb seal, eave clips, and intermediate eave clips to roof band.

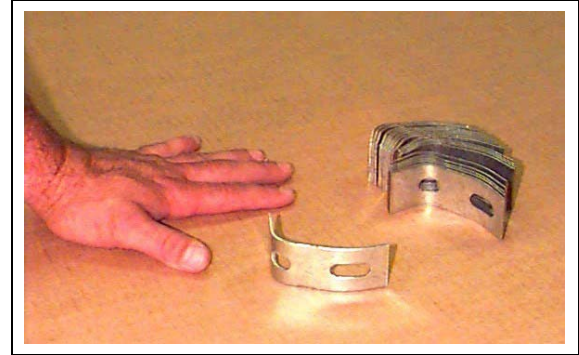

Figure 6J Intermediate Eave Clip



Figure 6K Installing eave clip and intermediate eave clips.

Tower Roof Hardware



Figure 6L

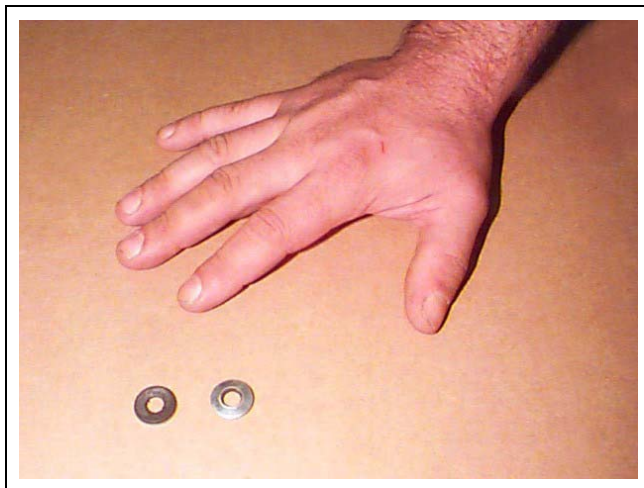
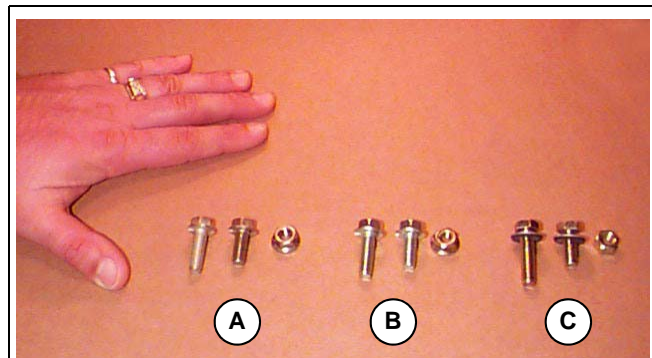

Figure 6M Close Up - Neoprene Washers



- A. Stainless steel, whiz lock
 Bolts = Dull gray
 Nuts = Shiny gray (with flange)
- B. Galvanized, whiz lock
 Bolts = Shiny gray
 Nuts = Yellow (with flange)
- C. Bin, hex head
 Bolts = Yellow (with neoprene washers)
 Nuts = Yellow (no flange)

Figure 6N Comparison of 5/16" Hardware

6. Tower Roof

Tower Roof Center Collar

1. Bolt three (3) tower roof center collar sections together.

Use 5/16" x 3/4" bin bolts, grade 5 bolts, 5/16" hex head nuts, and neoprene washers.

NOTE: Insert bolts toward inside of center collar, with neoprene washers against outside of center collar to provide seal.

2. Position tower roof center collar above peak cap, in center of dryer.



Figure 6O Tower Roof Center Collar Section (1 of 3)

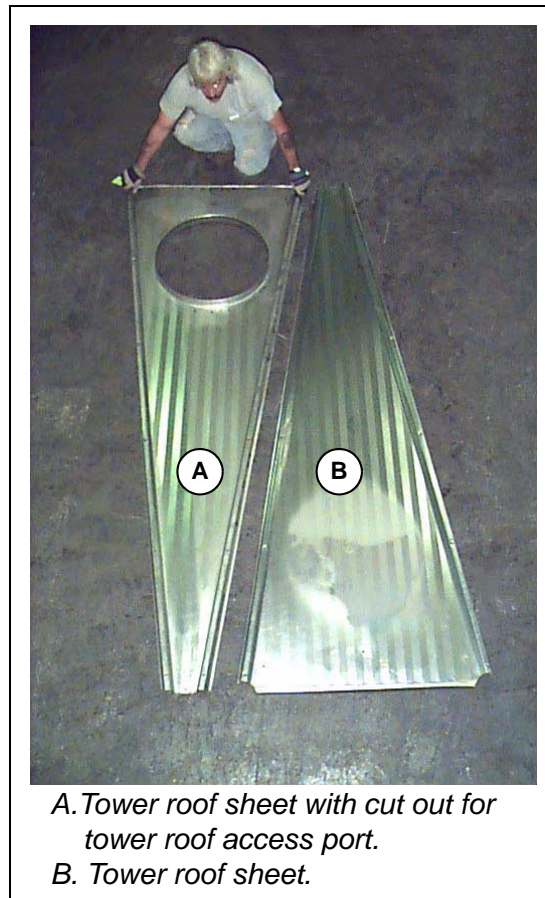

A. Tower roof sheet with cut out for tower roof access port.
B. Tower roof sheet.

Figure 6P

Tower Roof Sheets, Tower Roof Rungs and Expansion Ring Clips

NOTE: *Install roof rungs and expansion ring clips to tower roof sheets during tower roof sheet installation.*

Vertical Tower Roof Seams

Use 5/16" x 1-1/4" bin bolts, grade 5 bolts, 5/16" hex head nuts, and neoprene washers.

Leave out second to top bolt in tower roof vertical seams for center collar flashing installation.

Horizontal Tower Roof Seams

Use 5/16" x 3/4" bin bolts, grade 5 bolts, 5/16" hex head nuts, and neoprene washers.

All tower roof seams and add on parts:

Insert bolts toward inside of dryer, with neoprene washers against outside of dryer to provide seal.



Figure 6Q *Install roof rungs on ribs of the tower roof sheet with cut out for access port.*



Roof access port must be safely accessible from outside tower ladder.

Install tower roof sheet with cut out for roof access port directly above where outside ladder will be installed. (If no peak walk used.)

If there is an optional peak walk to install locate roof access point directly above roof hatch platform.

6. Tower Roof

From opposing sides of dryer, bring first pair of tower roof sheets together to tower roof center collar in center of dryer. Position tower roof sheet with cut out for roof access port directly above where outside ladder will be installed.

Snug bolt top bolt hole of tower roof sheets to outside bottom of tower roof center collar. Snug bolt bottom bolt hole of tower roof sheets to eave clips, and intermediate eave clips. Leave other bolt holes on ribs (vertical seams) open.

Bring second pair of tower roof sheets together to tower roof center collar and snug bolt at top and bottom like first pair.

Check to be sure peak assembly is centered on dryer.

Install remaining tower roof sheets as above, then fill in vertical and horizontal seams. Leave second to top bolt hole open for center collar flashing installation. Completed tower roof sheets will overlap with common bolts in ribs.

Wait to tighten tower roof bolts until after expansion ring is loosely installed to tower roof.



Figure 6R Bringing two (2) opposing tower roof sheets to tower roof center collar. Position tower roof sheet with access port cut out directly above where outside ladder will be.

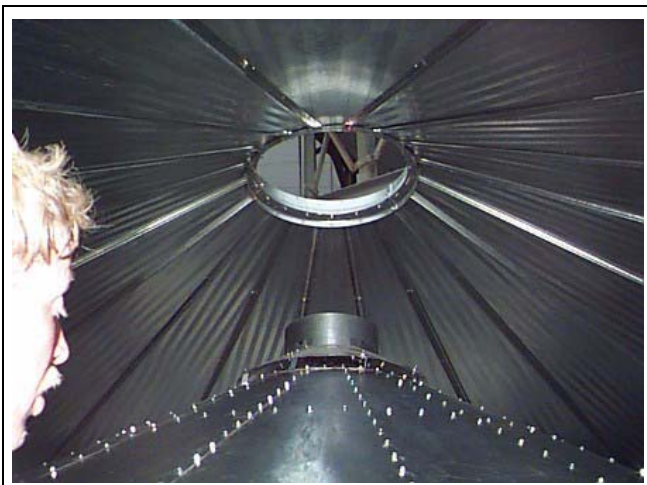

Figure 6S Inside view - Peak of tower roof sheets bolts to bottom of tower roof center collar.



Figure 6T Inside view - Tower roof sheets bolt to eave clips, and intermediate eave clips.

Install roof rungs and expansion ring clips to tower roof sheets during tower roof sheet installation.

Count bolt holes (BH) from bottom of rib of tower roof sheet.

- Set of four (4) roof rungs - install across tower roof sheet with cut out for access port in BH1, BH3, BH4 and BH5.
- Remaining roof rungs - install across every other tower roof sheet in BH5.
- Install expansion ring clips in every BH3.

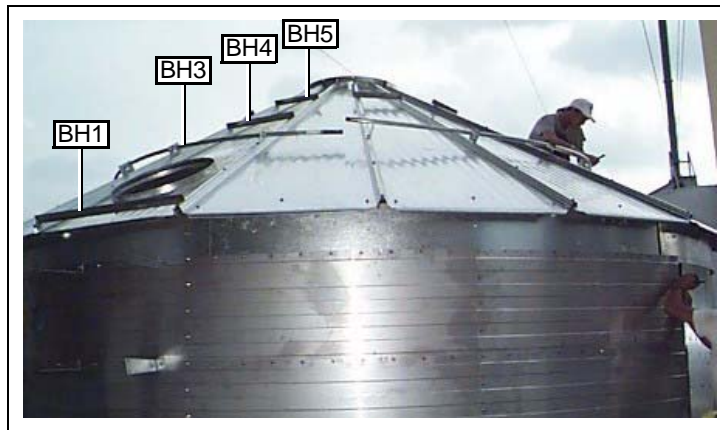

Figure 6U Bolt holes (BH) for tower roof rungs and expansion ring clips.

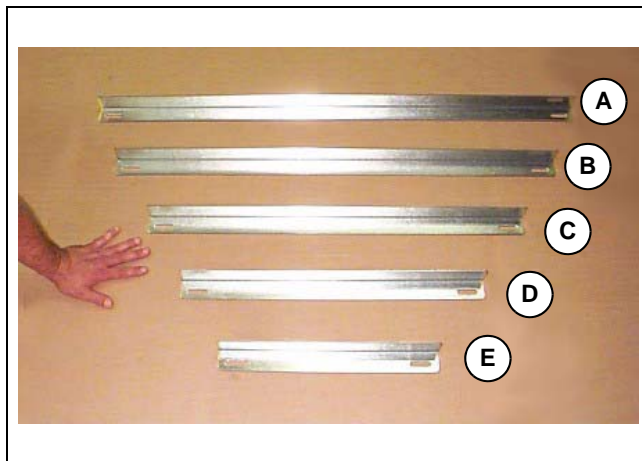

Figure 6V

Ref #	Length	Part	Qty
A	41-1/4"	Tower Roof Rung	1
B	36"	Tower Roof Rung	1
C	29"	Tower Roof Rung	1
D	22"	Tower Roof Rung	9
E	15"	Tower Roof Rung	1

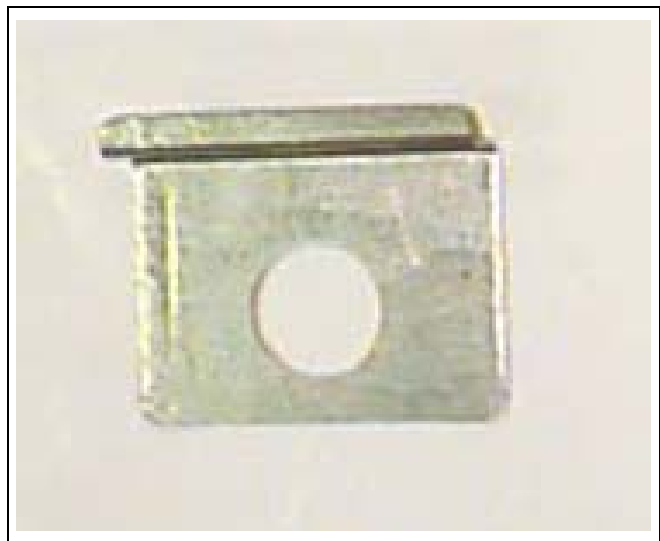

Figure 6W Expansion Ring Clip (4")

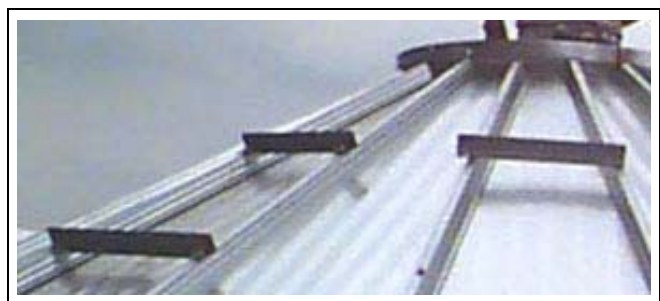

Figure 6X Close Up - Roof rungs installed to ribs of tower roof sheets.

6. Tower Roof

Expansion Ring

After expansion ring clips are installed to tower roof sheets, install expansion ring sections as follows.

Use expansion ring hardware. (See Figure 6AA on Page 79.) Double nut (spin two (2) nuts closely together) each expansion bolt.

NOTE: Expansion bolts should be fully contracted during installation. In other words, leave double nuts spun closely together until after expansion ring is complete.

1. Insert first expansion ring section into expansion ring clips.
Double nut an expansion bolt and screw into first expansion safety ring section.
Insert next expansion ring section into adjoining expansion ring clips. Screw second expansion ring section onto free end of first expansion bolt.
Continue installing expansion ring sections until ring is complete around tower roof.
2. Tighten all tower roof bolts, including bolts on eave clips and intermediate eave clips.
3. Tighten expansion bolts between expansion ring sections by spinning double nuts apart. Spin nuts evenly around tower roof until expansion ring lifts tower roof to show a slight crown.



Figure 6Y Expansion Ring Sections

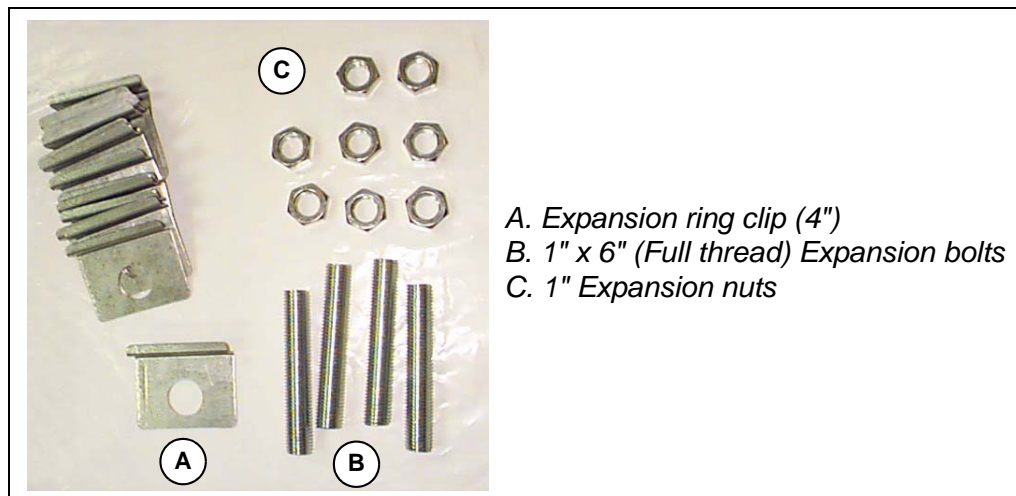

Figure 6Z Expansion Ring Hardware



Figure 6AA *Installing expansion ring to expansion ring clips.*



Figure 6AB *Close Up - Installing expansion ring and clips.*

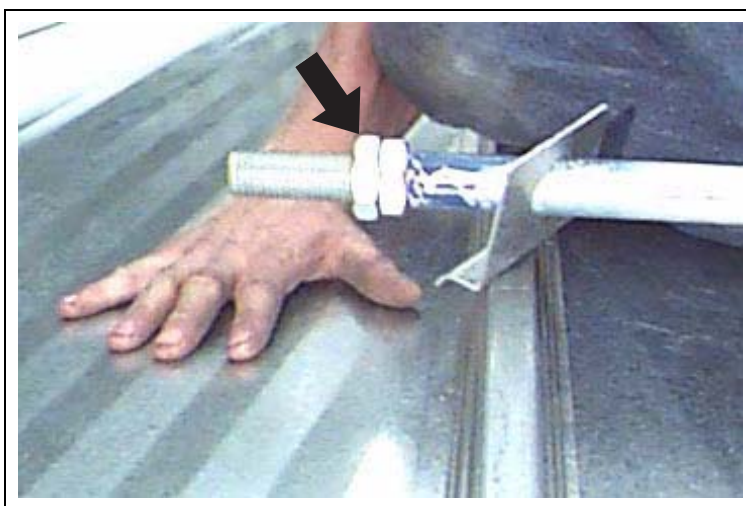

Figure 6AC *Double nut on fully contracted expansion bolt.*

6. Tower Roof

4. Install three (3) center collar flashing sections and caulk as follows.
 - a. Wipe oil from outside of tower roof center collar where center collar flashing section will join it. Press on strip caulking (24' rolls).
 - b. Align vertical edge of first center collar flashing section along a seam of center collar. Tabs of center collar flashing will fit over ridges in tower roof sheets.

Bolt using the following hardware.

Center Collar to Flashing Seam

Use 5/16" x 3/4" bin bolts, grade 5 bolts, 5/16" hex head nuts, and neoprene washers.

Flashing to Tower Roof Sheet Rib Seam

Use 5/16" x 1-1/4" bin bolts, grade 5 bolts, 5/16" hex head nuts, and neoprene washers.

- c. Install two (2) remaining center collar flashing sections in the same way.

NOTE: Apply strip caulking where center collar flashing sections overlap.

NOTE: Insert bolts toward inside of dryer, with neoprene washers against outside of dryer to provide seal.



Figure 6AD Center Collar Flashing Section (1 of 3)

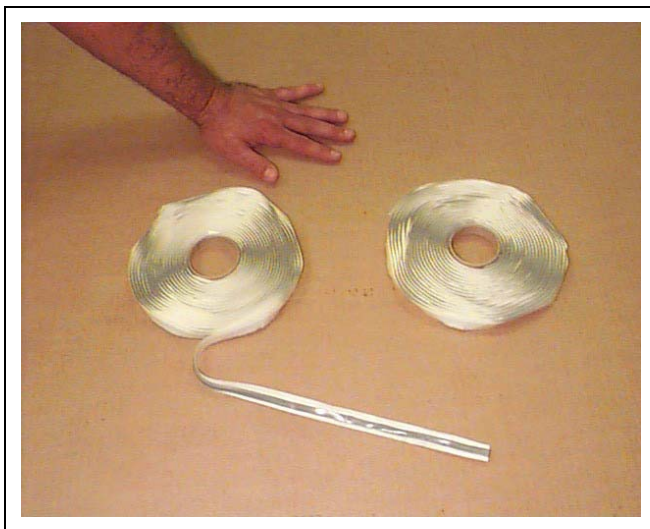

Figure 6AE Strip Caulking (24' rolls)



Figure 6AF Tightening center collar flashing bolts.

Fill Tube Weldment

Insert fill tube weldment into center collar.



Figure 6AG *Fill Tube Weldment*

Access Port Cover

Install access port cover to the tower roof sheet that has a cut out for the access port as follows.
(See [Figure 6C on Page 69.](#))

1. Locate where moisture diverter will join access port tower roof sheet. Wipe area clean of oil and press on strip caulking (24' rolls) to cover bolt holes.
 2. With common bolts, bolt moisture diverter, then hinge base to access port tower roof sheet. Use 5/16" x 3/4" stainless steel whiz lock bolts and nuts.
 3. Use 3/8" x 1" stainless steel whiz lock bolts and nuts to bolt the following parts.
 - Hinge leaf to access port cover.
 - Hinge leaf to hinge base. Use double nut.
 4. Place handle gasket under handle and bolt to access port cover.
Use two (2) 10-24 x 5/9" bolts and lock nuts.
- NOTE:** *Insert handle shaft toward inside of dryer.*
5. Bolt latch to shaft of handle as follows.
 - Insert 5/16" x 1-1/4", grade 5 bolt with nut and neoprene washer into latch.
 - Spin nut onto bolt.
 - Slide latch onto shaft of handle, up or down until it will catch bottom of tower roof sheet.
 - Tighten bolt to lock.
 6. **Bulb seal.** Press pre-cut bulb seal onto rim of access port cut out on tower roof sheet.



Figure 6AH Access door cover with “DANGER - Avoid Suffocation” decals.

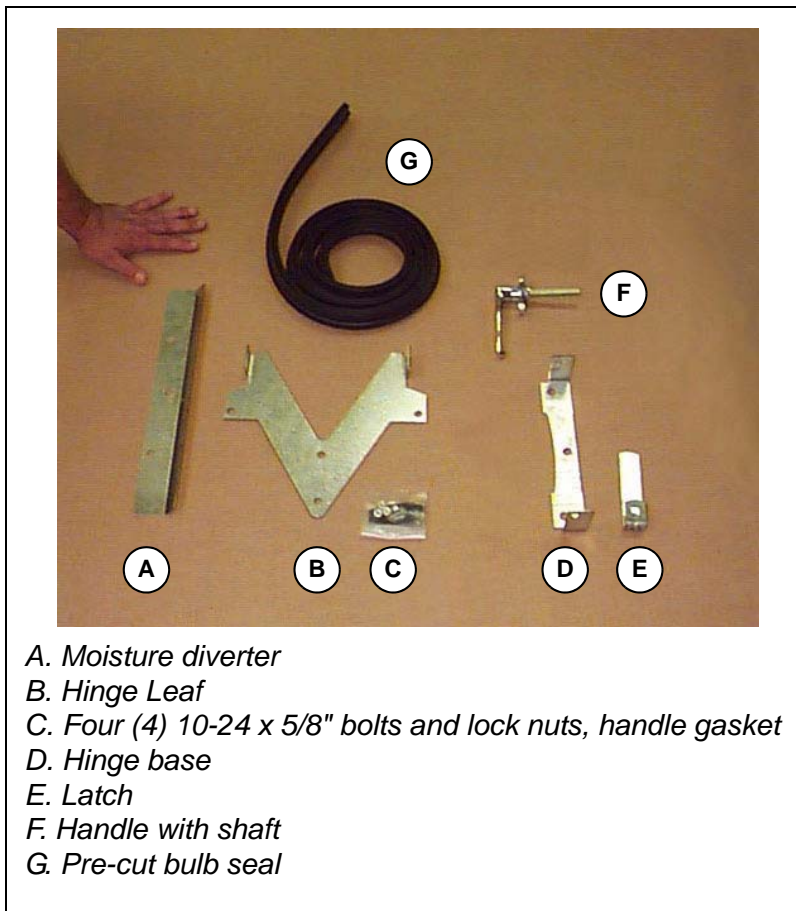

Figure 6AI Access Port Cover Hardware Package



Figure 6AJ *Pressing pre-cut bulb seal on rim of access port cut out on tower roof sheet.*



Figure 6AL *Inside View - Access Port Cover Installed*



Figure 6AK *Close Up - Access port cover installed.*



Figure 6AM *Outside View - Access port cover installed.*

6. Tower Roof

Outside Wall Sheets

Install two (2) rows of solid outside wall sheets (20" high) to vertical channels.

NOTE: Use common bolts to install brackets for outside ladder with safety cage. (See [Outside Ladder on Page 86.](#))

Install perforated sheets as required.

See [Orientation Section on Page 19](#) for illustrations and wall sheet installation guidelines.

Attachment of Roof Stairs Section

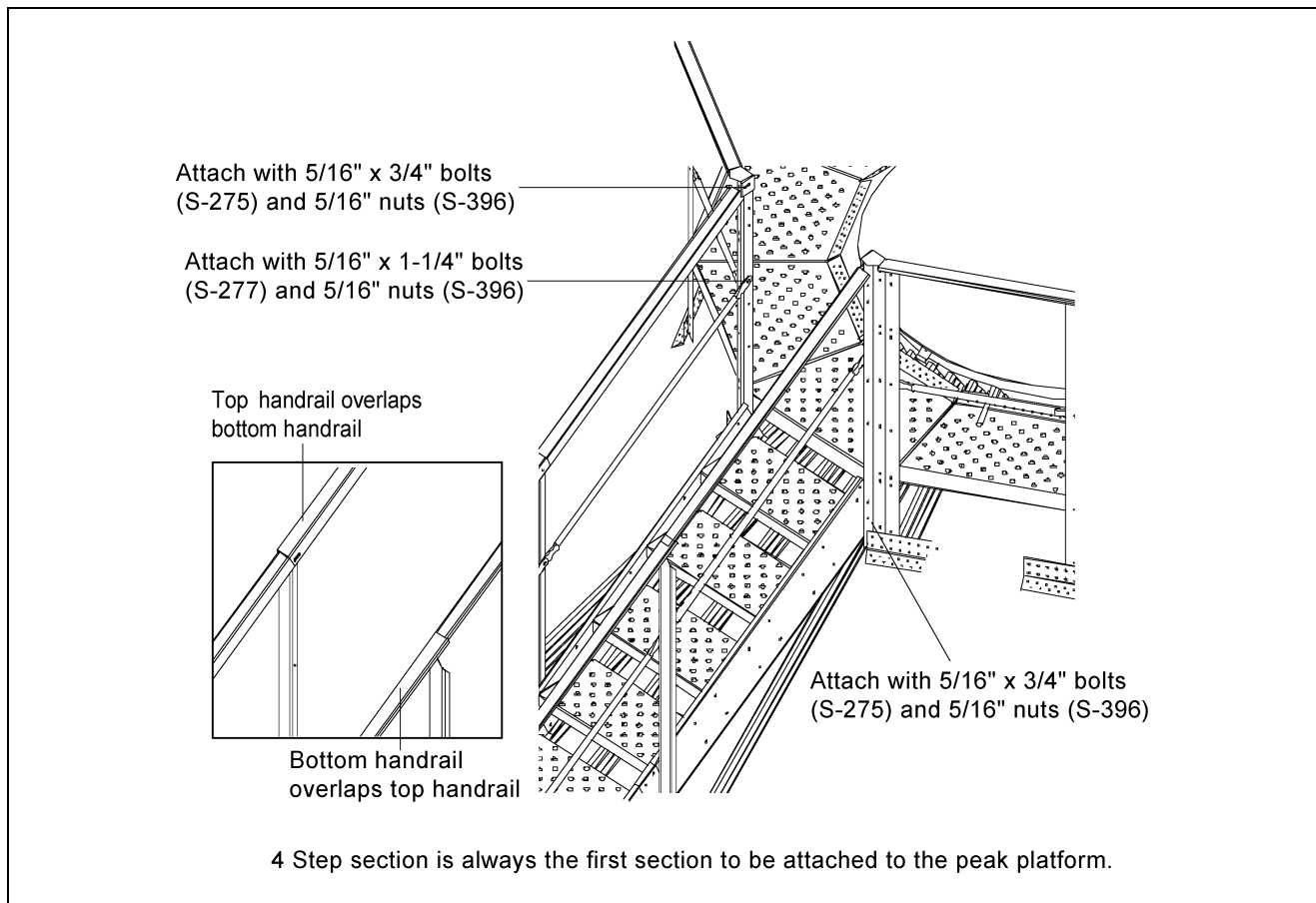
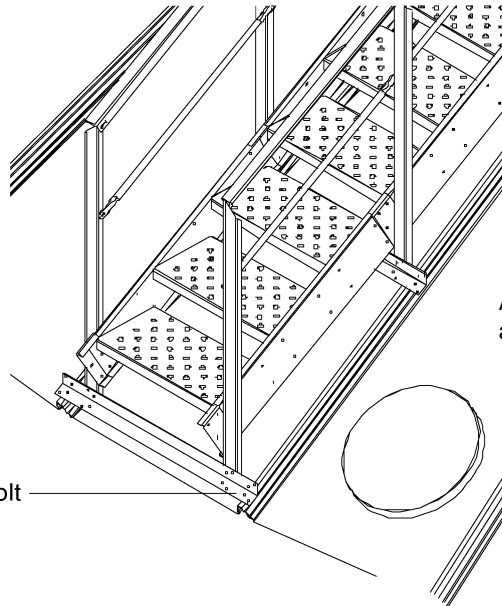

Figure 6AN

Bottom Section Attachment

Depending on the size of dryer, the bottom section of stairs may be a 3 step section or a 2 step section.



3 Step bottom section

Attach using the same process as shown [on Page 84](#).

Field drill all rib spanning brackets and roof rib, and fasten with 5/16" x 1-1/4" bolt (S-277) and 5/16" nut (S-396).

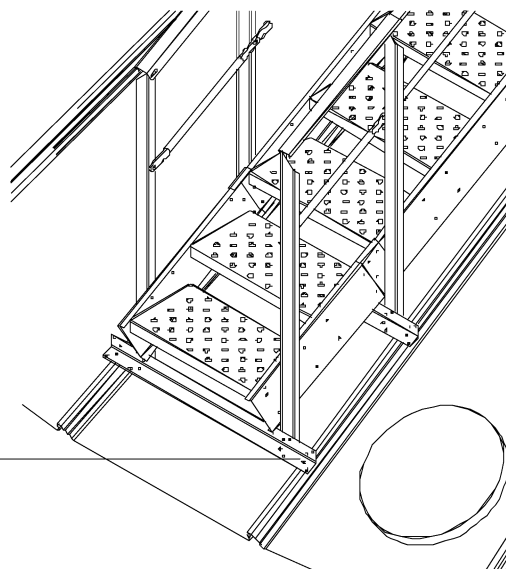

2 Step bottom section

Attach using the same process as shown [on Page 84](#).

Field drill all rib spanning brackets and roof rib, and fasten with 5/16" x 1-1/4" bolt (S-277) and 5/16" nut (S-396).

On the 2 step channel, there is only one way for the channel to attach to the previous section [on Page 84](#).

Figure 6AO

Outside Ladder with Top Safety Cage

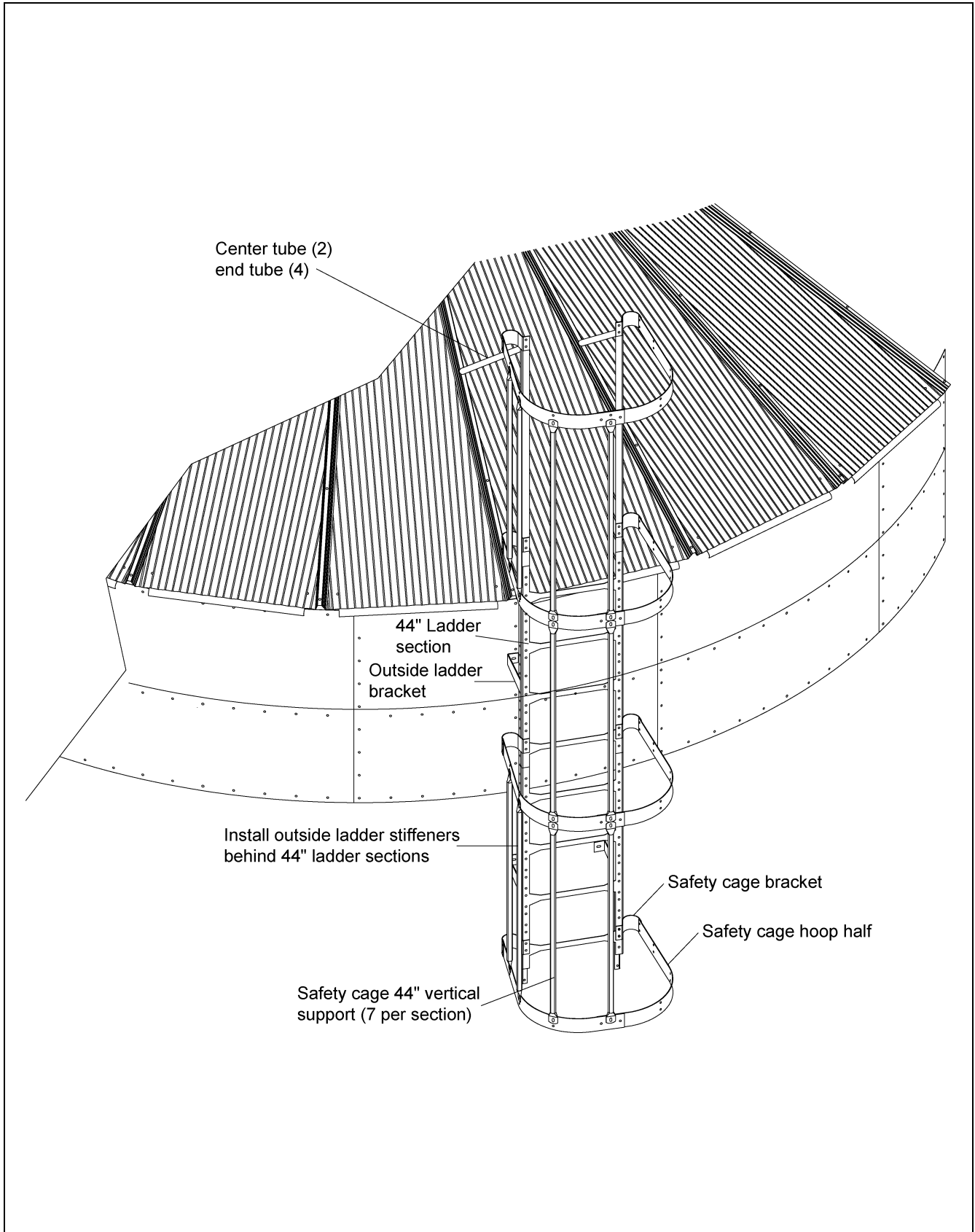

Figure 7A



Important Safety Precautions:

Dryer has sharp edges. These sharp edges may cause serious injury. Use appropriate personal protective equipment. Use proper lifting techniques.

See [Orientation Section on Page 19](#) for dryer dimensions, components, wall sheet guidelines, etc. See [Appendix A on Page 435](#) for tools and equipment, [Appendix B on Page 437](#) for hardware, etc.

Installing Outside Ladder with Safety Cage

Outside Ladder Bracket

Install outside ladder brackets to outside wall sheets as follows.

Use 5/16" x 1" stainless steel whiz lock bolts and nuts. **Double nut** with second 5/16" whiz lock nut.

Outside Ladder Bracket Placement Down Length of Dryer

Outside ladder brackets support outside ladder with safety cage from garner of dryer to foundation. Place outside ladder brackets so that top safety cage will be centered directly below tower roof access port.

Tower roof access port was positioned so outside ladder with safety cage can be installed to the left of a vertical channel.

- Bolt first outside ladder bracket on roof band to solid wall sheet seam, in first bolt hole to left of vertical channel.
- Bolt second outside ladder bracket on roof band to solid wall sheet seam, in fourth bolt hole to left of vertical channel.
- Repeat above steps on next seam (which is between two (2) solid wall sheets), then on every other seam on outside of dryer.

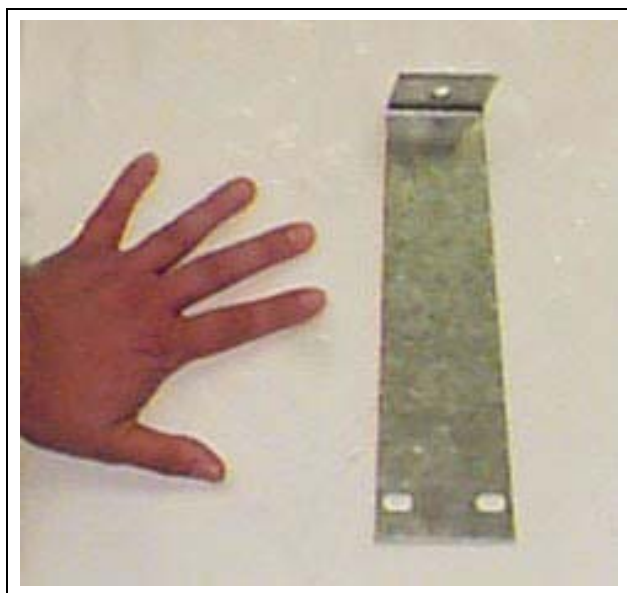

Figure 7B Outside Ladder Bracket

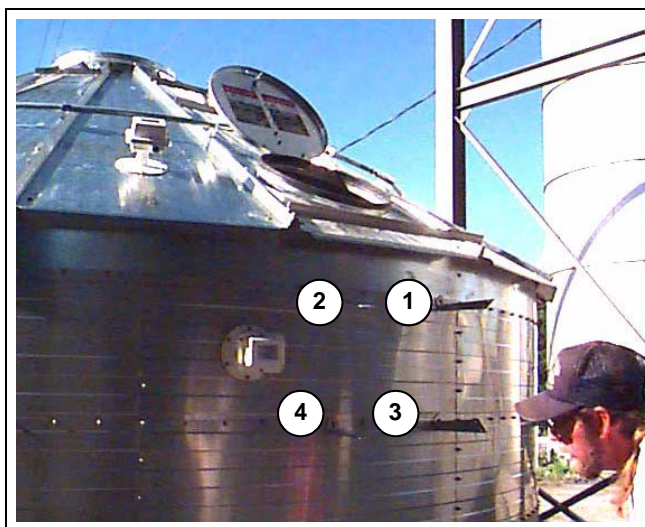

Figure 7C First four (4) outside ladder brackets loosely bolted below tower roof access port, marked (1),(2), (3) and (4).

7. Outside Ladder

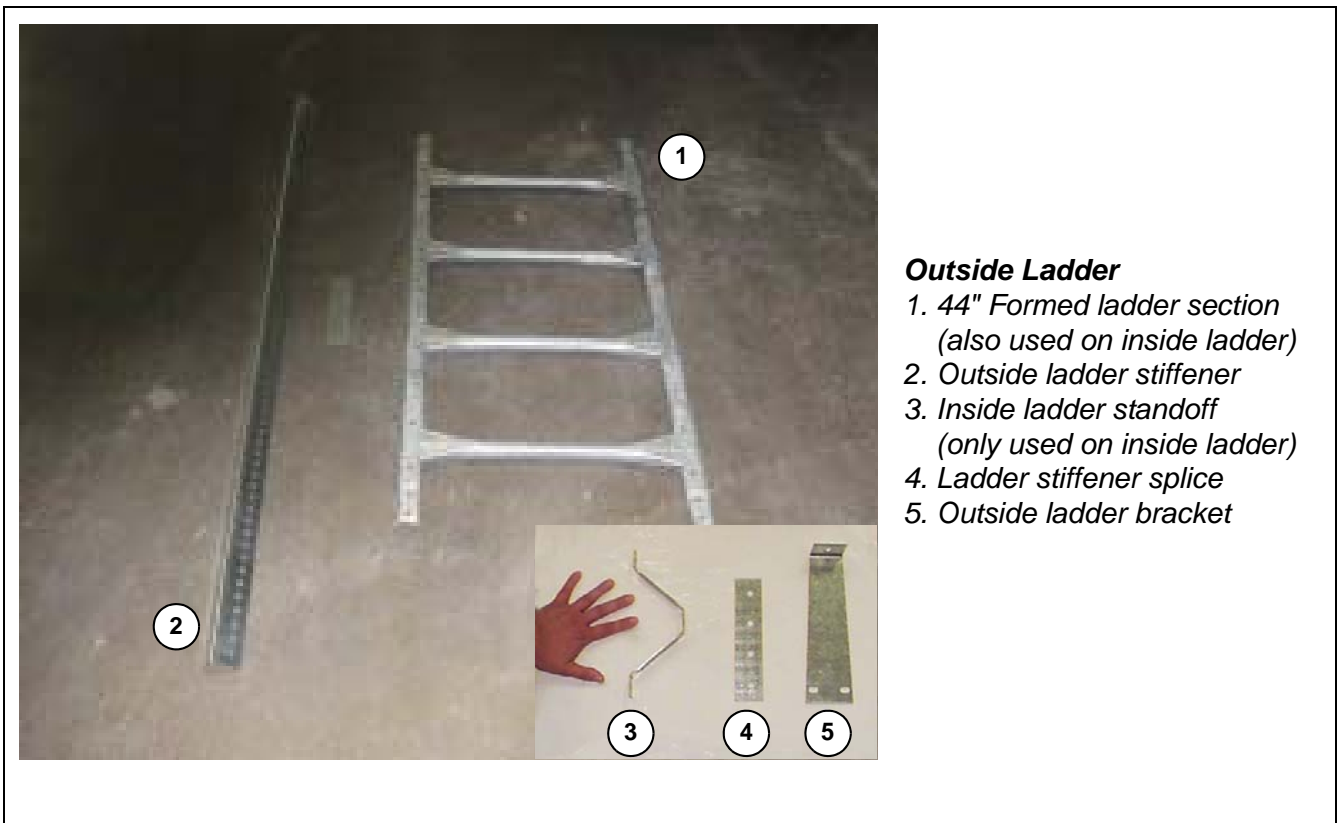

Figure 7D

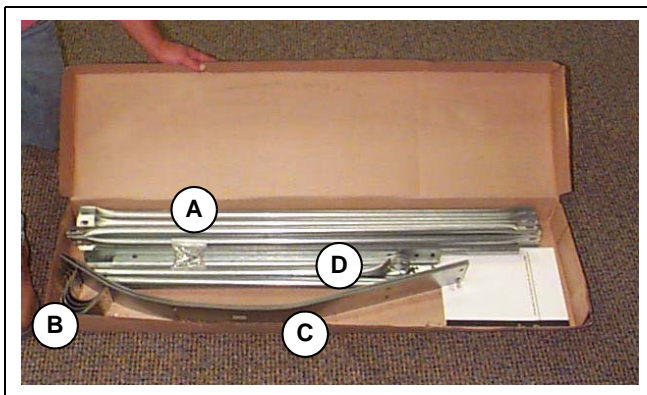

Figure 7E Top Safety Cage

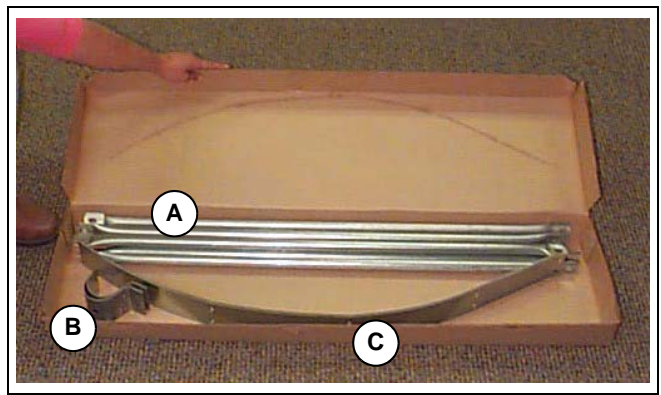

Figure 7G Bell safety cage has larger bell-shaped hoops.

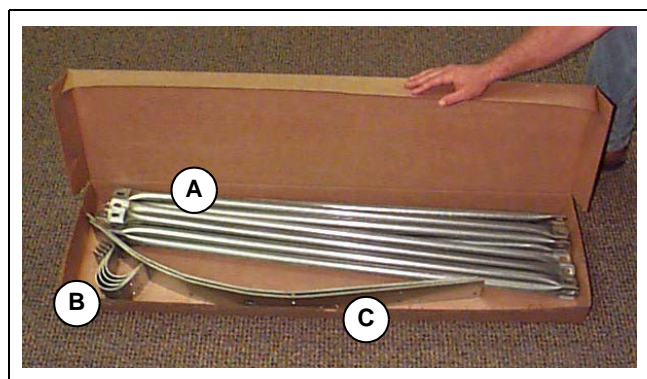

Figure 7F Safety Cage Extension

Safety Cage

- A. 44" Vertical supports
- B. Safety cage brackets
- C. Safety cage hoop halves
- D. End tubes and center tubes

Top Safety Cage

Pre-assemble top safety cage as follows. (See Figure 7H and Figure 7I.)

1. Snug bolt one (1) 44" formed ladder section to two (2) outside ladder stiffeners. Snug bolt four (4) safety cage brackets to outside ladder stiffeners.
2. Bolt pairs of safety cage hoop halves together. Snug bolt safety cage hoops to safety cage brackets.
3. Snug bolt seven (7) 44" vertical supports to safety cage hoop halves.
4. Snug bolt top safety cage assembly to outside ladder brackets. Tighten bolts.



Figure 7H

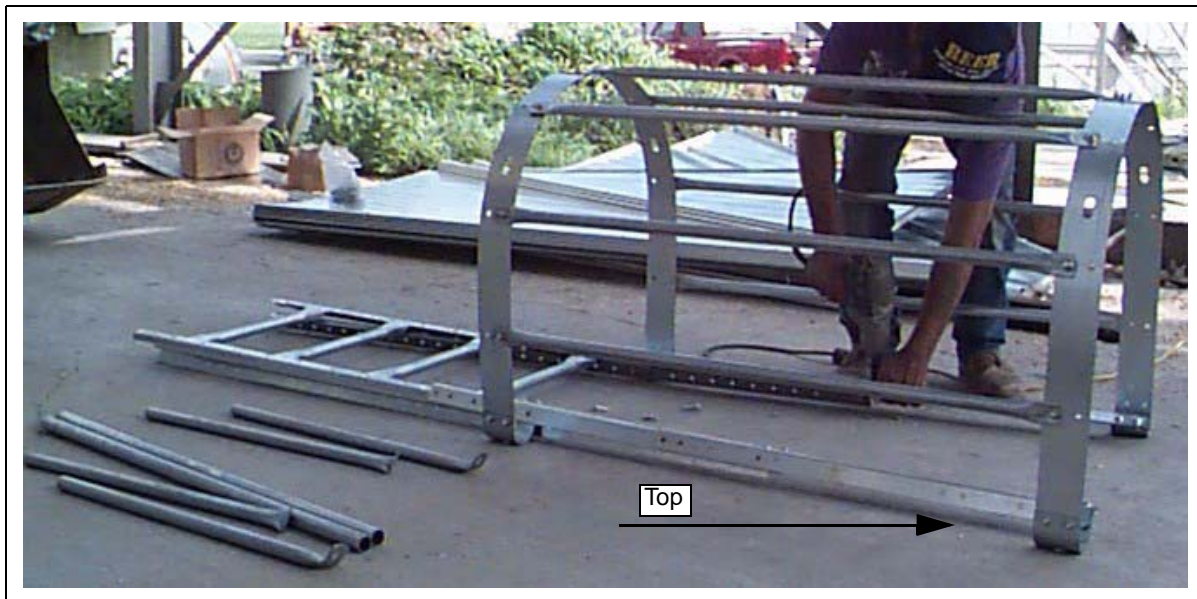

Figure 7I

7. Outside Ladder



Install all 44" formed ladder sections so rungs with rough, textured side for gripping are on top, so climbers do not slip.

When Assembling Ladder and Safety Cage

Use 5/16" x 3/4" galvanized whiz lock bolts and nuts.

When Installing Ladder and Safety Cage to Dryer

Use 5/16" x 3/4" stainless steel whiz lock bolts and nuts.



LADDER BOLTS - insert bolts toward outside of ladder, so climbers do not snag on bolt shafts.



Figure 7J Close Up - Shaft of bolts point out of safety cage so climbers do not snag.

5. Secure top safety cage to tower roof ribs as follows.

- With common bolt, snug bolt first end tube to outside ladder stiffener.
- Fit center tube into first end tube.
- Fit second end tube into center tube.
- Snug bolt second end tube to rib of tower roof above tower roof access port with existing 5/16" x 1-1/4", grade 5 bolts, hex head nuts, and neoprene washers.

6. Square top safety cage assembly.

Check to be sure top safety cage assembly is plumb with dryer, then tighten bolts.



Install all 44" formed ladder sections so rungs with rough, textured side for gripping are on top, so climbers do not slip.



Figure 7K *Installing top safety railing and peak walk to tower roof.*

7. Outside Ladder

Safety Cage Extensions

Install safety cage extensions from top safety cage to bell safety cage just above foundation as follows. Quantity depends upon dryer model.

1. Splice outside ladder stiffeners with ladder stiffener splices. Snug bolt outside ladder stiffeners behind 44" formed ladder sections. Install safety cage brackets and safety cage hoops like top safety cage.
2. Before lifting each section, tighten bolts in outside ladder with safety cage for that section.

As dryer is constructed, continue installing safety cage extensions to each section of dryer before lifting it.



Figure 7L Close Up - Pointing to ladder stiffener splice. Install ladder stiffener splice with 4 bolts (circle).



Figure 7N Close Up - Outside Ladder Brackets

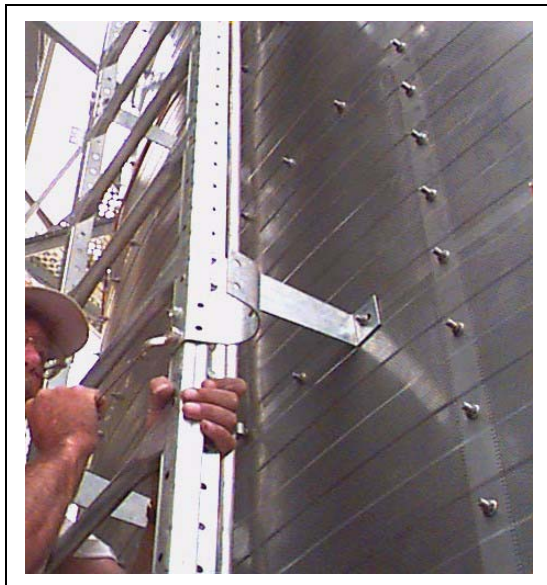

Figure 7M Outside ladder bracket bolts through 44" formed ladder sections and outside ladder stiffener.



Figure 7O As dryer is constructed, continue installing outside ladder with safety cage.

While Installing each Catwalk, Install Outside Ladder with Safety Cage

1. **Above catwalk:** Halt safety cage 7' 8' above catwalk. Continue outside ladder through catwalk.
2. **Below catwalk:** Measure, cut, and install safety cage 44 vertical channel supports to meet bottom of catwalk. Continue installing outside ladder with safety cage.

While Installing each Platform, Secure Outside Ladder with Safety Cage to it.

Bend and cut safety hoops to meet vertical uprights on catwalk or platform. Trim safety hoops back where necessary for access to platform.



Figure 7P Close Up - Securing safety hoop to vertical support.



Figure 7Q Ground view - Ladder with safety cage installed through catwalks and to platform.

NOTE: Platform design may vary from above design.



Figure 7R Close up - Installing upper and lower safety hoops to platform vertical supports.



Figure 7S View from platform - Safety hoops installed to platform vertical supports.



Figure 7T Trim and bolt safety hoops to platform vertical support as necessary.



Figure 7U Close Up - Installing bell safety cage.

Bell Safety Cage

About 10' above foundation, install bell safety cage as the last section of the outside ladder with safety cage. Install like safety cage extensions. (**NOTE:** Bottom of bell must be 7' to 8' above platform or ground directly below bell.)



Figure 7V Bell safety cage installed.

7. Outside Ladder

Outside Ladder from Bell Safety Cage to foundation

1. Continue installing outside ladder (no safety cage) from bell safety cage until outside ladder meets foundation.

2. Ladder Support Channels

NOTE: Install ladder support channels after X-rod are installed.

Use 5/16" x 1" galvanized whiz lock bolts and nuts.

Measure and drill dryer Legs on both sides of outside ladder for three (3) ladder support channels. Space equally.

Bolt three (3) ladder support channels to span dryer legs.

NOTE: Ladder bracket extensions offset outside ladder at base of dryer for ease in mounting ladder. Install as follows.

Bolt outside ladder brackets to outside ladder.

Bolt ladder bracket extensions to outside ladder brackets. (The bracket [of both angle parts should face the same way.)

Bolt ladder bracket extensions to ladder support channels.

Outside Ladder Support (Optional)

Support bottom of outside ladder to concrete foundation. Length of support varies. Support not supplied by Grain Systems.

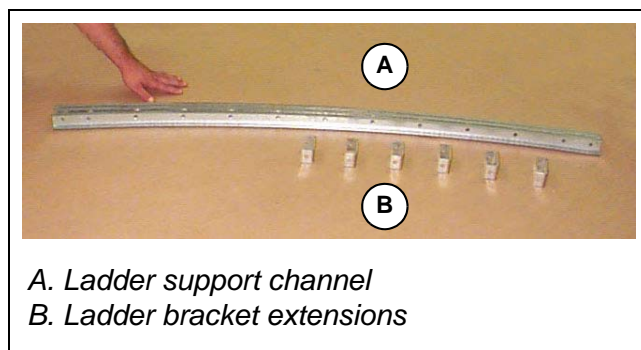

Figure 7W

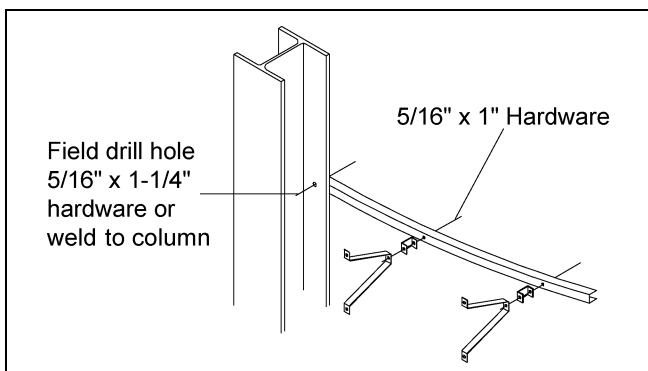

Figure 7X Ladder Support

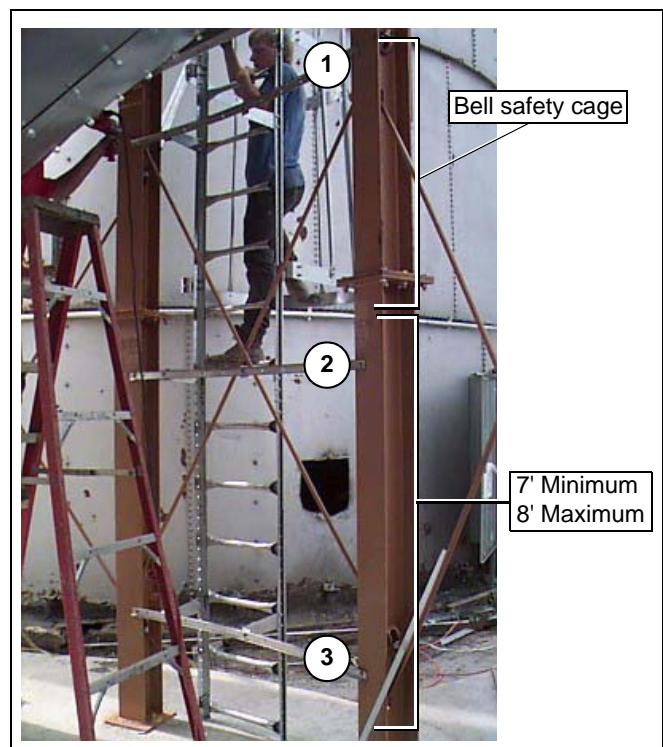

Figure 7Y Bracing ladder at base of tower with ladder support channels, marked (1), (2) and (3).

NOTE: Usually outside ladder support can be made of 1" x 1" x 1/8" angle iron bolted directly to outside ladder, using 5/16" x 1" galvanized bolts and nuts.

Sensors Placement

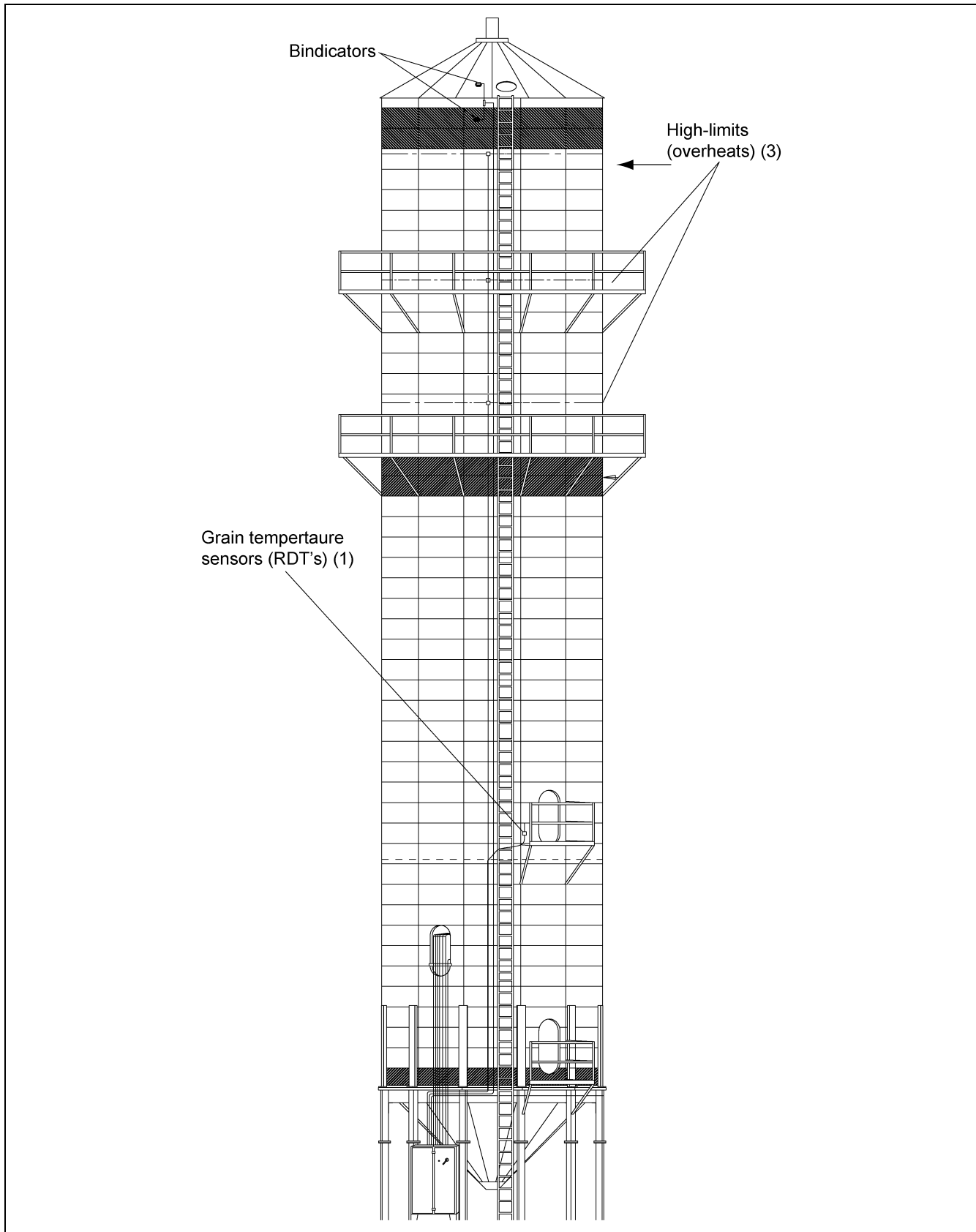

Figure 8A

Bindicator(s) Placement - Detail

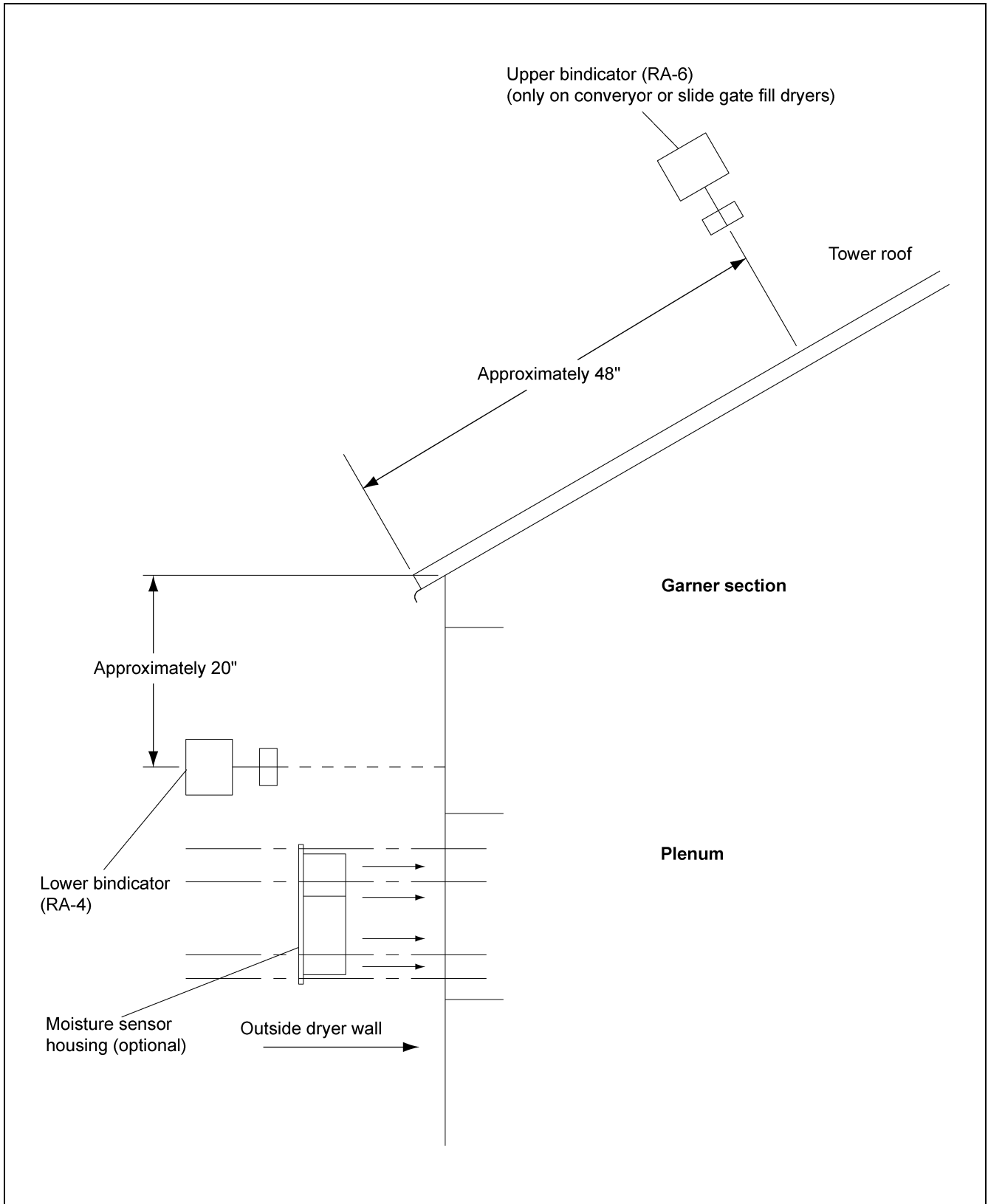

Figure 8B



Important Safety Precautions:
Dryer has sharp edges. These sharp edges may cause serious injury. Use appropriate personal protective equipment. Use proper lifting techniques.

See [Orientation Section on Page 19](#) for dryer dimensions, components, wall sheet guidelines, etc. See [Appendix A on Page 435](#) for tools and equipment, [Appendix B on Page 437](#) for hardware, etc.

Sensors (Outside)

Bindicator(s)

Grain Temperature Sensor (RTDs, Resistance Temperature Device)

High-Limits (Overheats)

Summary

Bindicator(s)

Lower bindicator is installed on side of dryer, just below garner section of dryer. Upper bindicator is only installed on conveyor or slide gate fill dryers. Install bindicator(s) within easy reach of outside ladder for later wiring.

Electricians will install conduit and wire bindicator(s).

Grain Temperature Sensor (RTDs)

Grain temperature sensor is installed within reach of outside ladder at burner access door location.

Electricians will install conduit and wire grain temperature sensors.

High-Limits (Overheats) (3)

Upper High-Limit, middle High-Limit, and lower High-Limit (each with copper tubing) are installed on perforated sheets, between top row of solid sheets and (just above or just below) middle row of solid sheets (at grain turners). Locate Junction boxes under outside ladder.

Construction crew will install conduit connecting High-Limits and continue conduit down to about 10' above foundation. Electricians will wire High-Limits.

Hardware



Figure 8C 1/2" IMC Rigid, Threaded Conduit

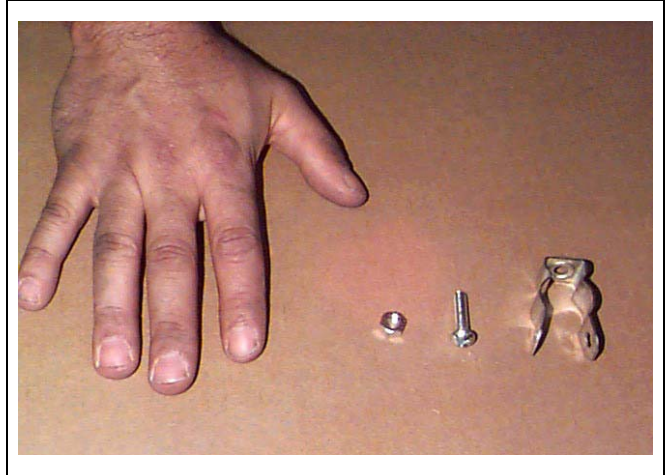

Figure 8E 1/2" Conduit Hanger



Figure 8D 1/2" Conduit Coupling

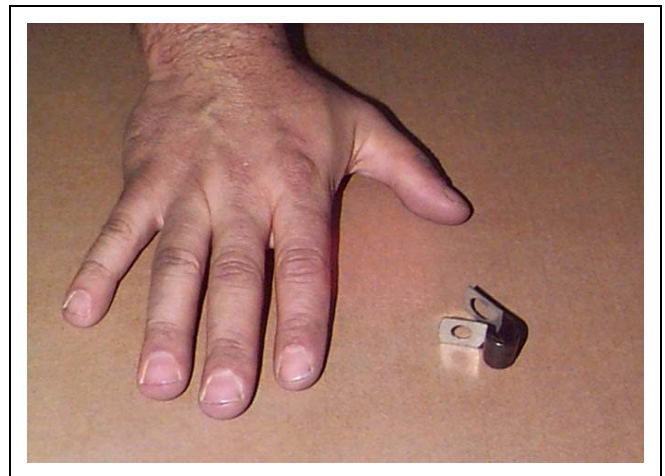
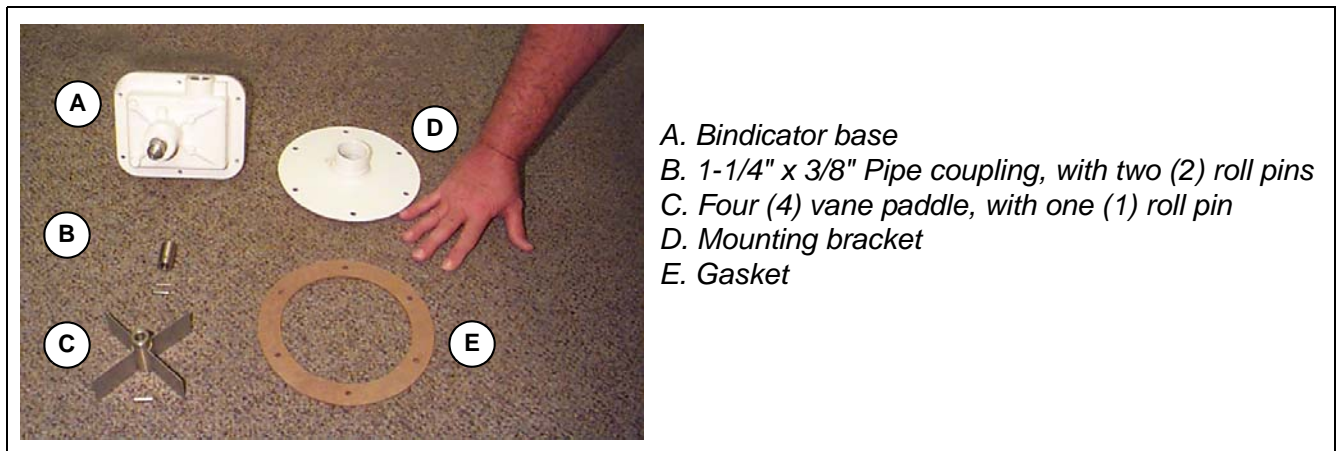

Figure 8F Insulated Clip

Indicator Parts



- A. Indicator base
- B. 1-1/4" x 3/8" Pipe coupling, with two (2) roll pins
- C. Four (4) vane paddle, with one (1) roll pin
- D. Mounting bracket
- E. Gasket

Figure 8G Indicator as shipped.



Figure 8H Bindicators (wired for demonstration)



Figure 8I

Bindicator(s)

Assemble bindicator(s) according to instruction sheet packed with them.

NOTE: See [Figure 8B on Page 98](#) for placement of bindicator(s).

1. Lower Bindicator, RA4

Measure inner (not outer) diameter of gasket. This is the diameter of hole needed to mount lower bindicator on wall sheet.

Locate wall sheet directly below access port. Center hole vertically on that wall sheet. Cut a hole in wall sheet that measures the same as gasket inner diameter.

Install assembled lower bindicator into hole cut in wall sheet, fitting gasket tight against wall sheet.

Bolt with 5/16" x 3/4" whiz lock bolts and 5/16" nuts.

2. Upper Bindicator, RA6

If required (for conveyor or slide gate fill dryers only), install upper bindicator on dryer roof.

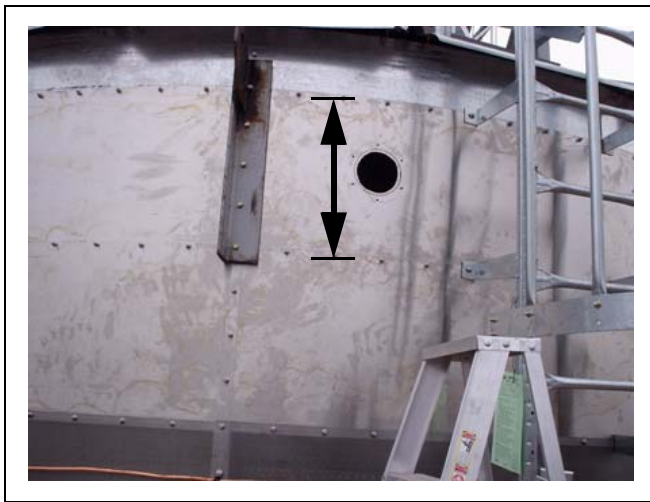

Figure 8J Center hole vertically for bindicator (arrows).



Figure 8L Upper bindicator (A) and lower bindicator (B) installed.



Figure 8K Installing upper bindicator.

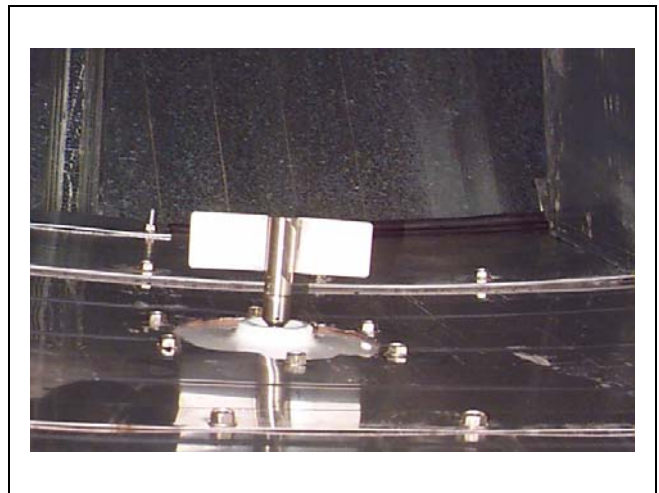

Figure 8M View inside dryer - Lower bindicator.

High-Limits (Overheats)

Install upper, middle and lower High-Limits on outside of dryer.

NOTE: See [Figure 8A on Page 97](#) for placement.

For sensors to work properly, it is important to install High-Limits on perforated sheets. Not on horizontal seams.

Position junction boxes with drainage holes down and behind outside ladder screw in conduit. Secure conduit close to junction box with 1/2" conduit hangers on existing bolts on seam.

Wrap copper tubing entirely around dryer. Clip with insulated clips.

Installing Copper Tubing

Install horizontal copper tubing as straight as possible and flush to dryer.

Secure copper tubing with insulated clips every 40". Insulated clips can be nipped down with second stainless steel nut over existing nut.



Do not kink or cut off end of gasfilled copper tubing.

Installing Conduit for High-Limits

- Install one (1) 1/2", 10' IMC rigid, threaded conduit between each High-Limits. Continue conduit down to approximately 10' above foundation.
- Join conduit lengths with 1/2" conduit couplings.
- Run conduit parallel or perpendicular to other conduits and dryer features.
- Vertical conduit run should be plumb, neat, and orderly.
- Conduit fittings must be dust-tight, raintight, and satisfy any hazard requirements for the site.
- Seal all threads with pipe thread sealer to tighten seals and prevent leaks.
- Use 1/2" conduit hangers every 80", and 5/16" whiz nuts.



Do not kink or cut off end of gasfilled copper tubing.



Figure 8N One (1) (outside) High-Limit consists of one (1) junction box and two (2) copper tubings.

8. Sensors

1. Install upper High-Limits.



Figure 8O Upper High-Limit installed with junction box under outside ladder (arrow).



Figure 8P Close Up - Upper High-Limit installed with junction box positioned under outside ladder.

2. Install middle High-Limits.

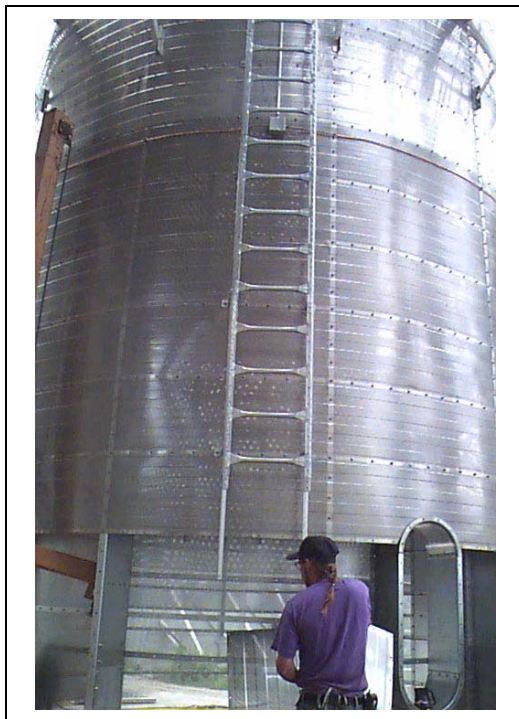

Figure 8Q Middle High-Limit installed.

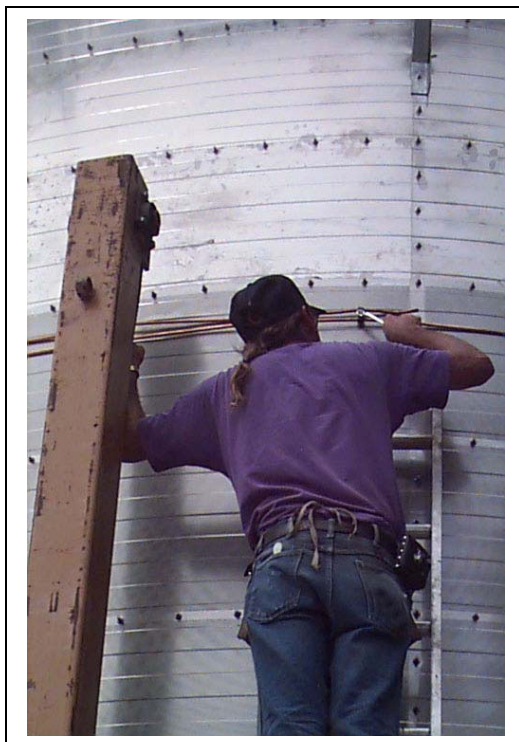

Figure 8R



Do not cut ends of copper capillary tubing. Overlap them.

8. Sensors

3. Install lower High-Limits.



Figure 8S *Installing lower High-Limit.*

NOTE: *Outside ladder will install over junction box.*



Figure 8T *Installing copper capillary tubing with insulated clips.*



Figure 8U *Close Up*

Grain Temperature Sensors (RTDs)

Install RTDs on outside of dryer, within safe reach of ladder.

There is one (1) RTD on a 10' length of 1/2" conduit.

Position RTDs according to [Figure 8A on Page 97](#). Drill hole in dryer wall for sensing bolt on each RTD. Add one (1) 3/8" washer to bolt/washer already on each RTD. Insert sensing bolt in hole. Secure conduit near RTD with 1/2" conduit hanger. Use existing bolts on seam.

NOTE: Do not place nut on inside of outside screen.

Placement of RTDs

Either RTD can be installed in top position.

R.H. Pair of RTDs

Install to right of outside ladder, and within reach of outside ladder.

Place R.H.-bottom RTD just above heat section floor.

R.H.-top RTD is on same conduit, 10' above bottom R.H. sensor.

L.H. Pair of RTDs

Install in next grain column over from R.H. pair of RTD, at the same level as R.H. pair, and within reach of outside ladder.

Installing Conduit for RTDS

- Run conduit parallel or perpendicular to other conduits and dryer features.
- Vertical conduits should be plumb, neat, and orderly.

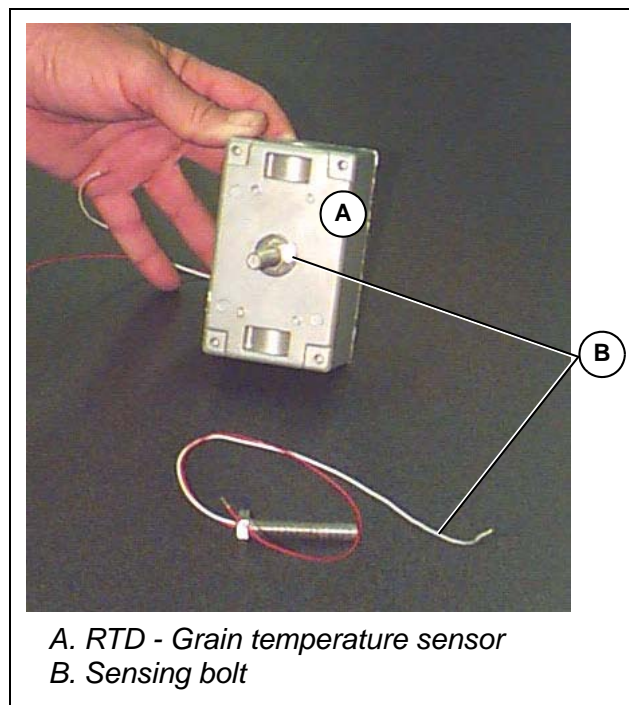

Figure 8V Grain sensor is embedded in stainless steel bolt.

NOTE: Either RTD on conduit can be installed in top position.



Figure 8W *Installing L.H. Pair of RTDs*

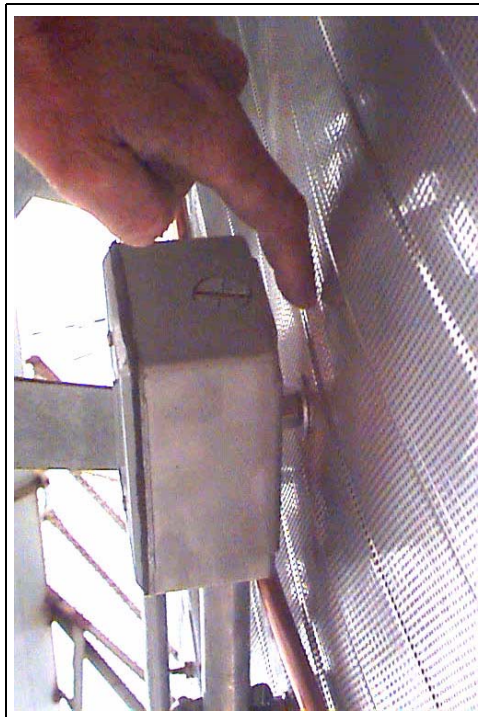

Figure 8X *Close Up - RTD Bolt with Sensor*



Important Safety Precautions:

Dryer has sharp edges. These sharp edges may cause serious injury. Use appropriate personal protective equipment. Use proper lifting techniques.

See [Orientation Section on Page 19](#) for dryer dimensions, components, wall sheet guidelines, etc. See [Appendix A on Page 435](#) for tools and equipment, [Appendix B on Page 437](#) for hardware, etc.

Steps to Lift Dryer

Vertical Channel Splice

Splice vertical channels together with vertical channel splices.

Use 3/8" x 1" galvanized steel bolts and nuts.



Figure 9A Vertical channel splice, 10 gauge.

Universal Shim Plate

To level dryer, shim dryer legs with universal shim plates. Use universal shim plates only for leveling jacks and completed dryer.

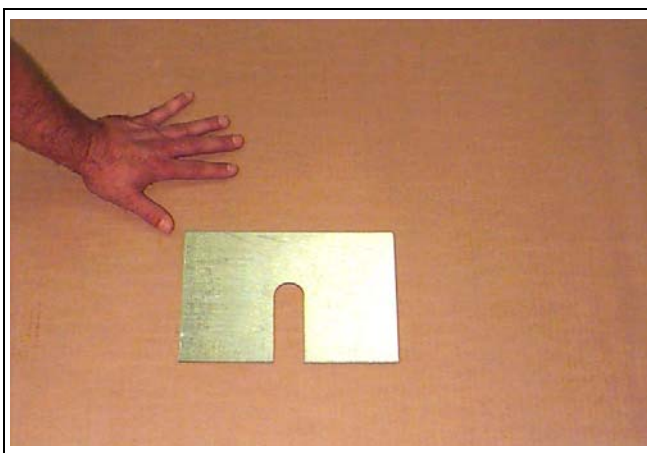

Figure 9B Universal shim plate. Use only for leveling jacks and completed dryer.



Safety check before each lift.

Tighten all bolts on dryer (except lower ladder parts).

Check for clearance from existing power lines, equipment and structures.
(See [Orientation Section on Page 19.](#))

Do not lift dryer when it is windy enough to shift jacked dryer.

Move next set of vertical channels near to dryer, and pre-install vertical channel splice to them.

Example: Lifting Roof Section



Before lifting roof of dryer, do safety check for wind or electrical hazards, clearance, etc. (See Orientation Section on Page 19.)

Tighten all bolts on dryer (except lower ladder parts).

Apply GSI decal.

1. Pre-install vertical channel splice plates to vertical channels to be installed after lift. Move vertical channels near to dryer.
2. It is recommended to place six (6) jacks around dryer as explained in lifting dryer guidelines [in Orientation Section on Page 42.](#)
3. Attach hoisting tackle from each jack to two (2) lift brackets according to jack manufacturer's instructions. Span two (2) lift brackets with lift bar so jacks do not block vertical rows of bolt holes.



Figure 9C Splicing vertical channels.

4. Unbolt dryer from jig clips. Lift dryer to clear next set of 80" vertical channels. Operate jacks according to jack manufacturer's instructions.
5. Slide each pre-spliced vertical channel (splice end up) to a vertical channel already on dryer, and position with alignment punches. Snug up lower vertical channel into upper vertical channel as tightly and evenly as possible.



Figure 9D Installing lift brackets.

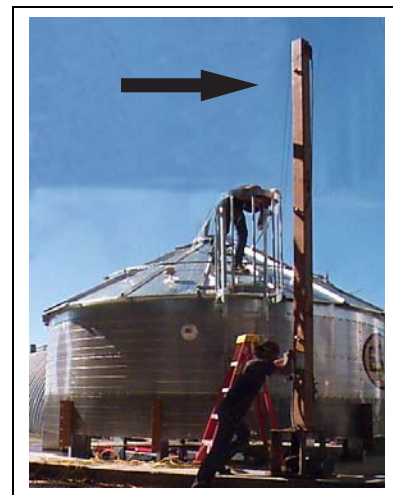

Figure 9E Placing jacks around dryer (arrow).

6. Lower dryer.

Check to be sure bottom of vertical channel is on outside of jig clip.



Figure 9F Positioning jack next to dryer.

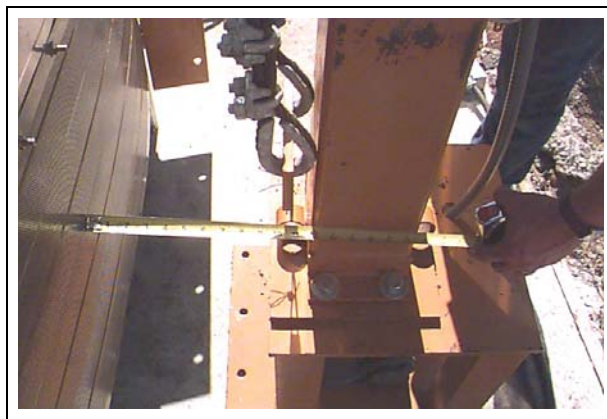

Figure 9G Checking jack is 11-1/2" to 12" from dryer.

7. At top, loosely bolt vertical channel splices to vertical channel already on dryer. At bottom, loose bolt vertical channels to jig clip to align dryer.

8. As each lift of dryer is constructed, install wall sheets, ladders, catwalks, platforms, and other dryer features as required. ([See Orientation Section on Page 19.](#))



Figure 9H Checking jack is plumb and level.



Figure 9I Jacks in place around dryer.

9. Lift Dryer



Figure 9J Raising Dryer (Crane shown here).



Figure 9M Bolting vertical channels.



Figure 9K Sliding vertical channel up to vertical channel on dryer.



Figure 9N Close Up - Bolting vertical channels.



Figure 9L Aligning vertical channels.



Figure 9O Lowering vertical channel on outside of jig clip.



Figure 9P Bolting vertical channel to jig clip.



Figure 9Q Removing lift bracket.

Outside Catwalk

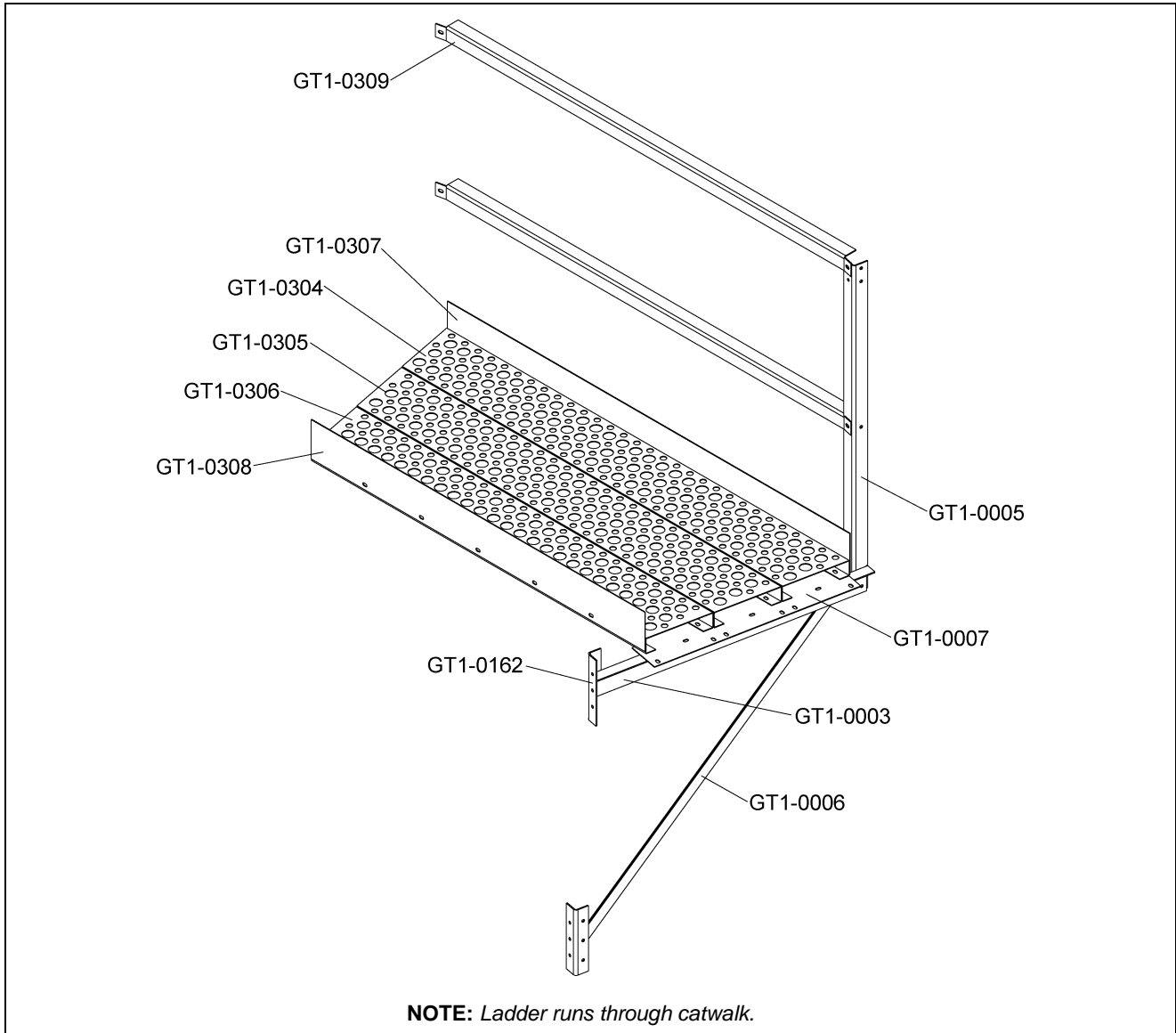

Figure 10A

Part #	Description	Qty
GT1-0003	Catwalk Floor Support	16
GT1-0005	Catwalk Vertical Support	16
GT1-0006	Catwalk 45 Support	16
GT1-0007	Catwalk Splice Plate	16
GT1-0162	Catwalk Support Clip	32
GT1-0304	Large Floor Plank	15
GT1-0305	Medium Floor Plank	15
GT1-0306	Small Floor Plank	15
GT1-0307	Outer Toeboard	15
GT1-0308	Inner Toeboard	15
GT1-0309	Catwalk Handrail	32

Quantity is for one (1) outside catwalk.

Inside Catwalk

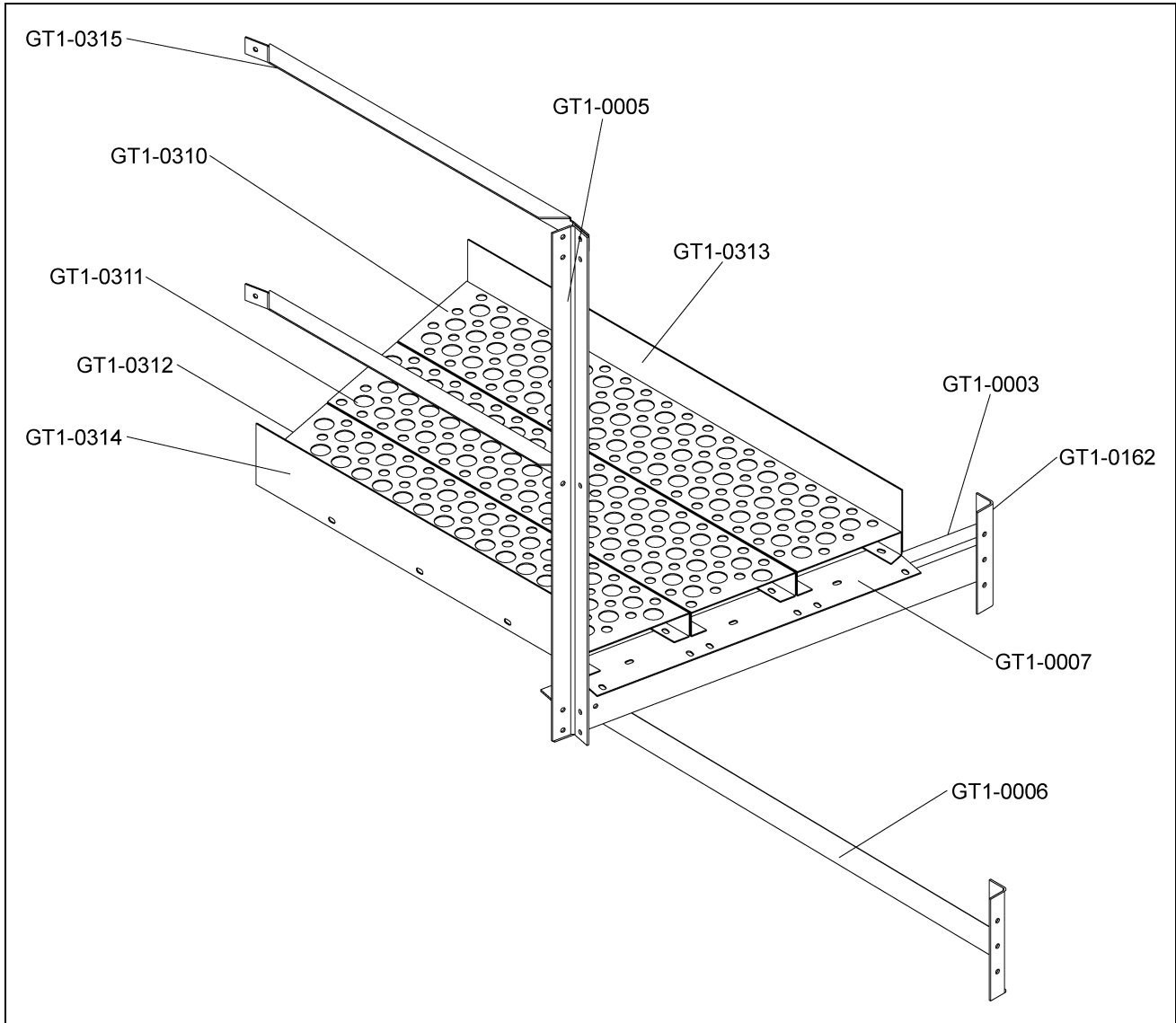

Figure 10B

Part #	Description	Qty
GT1-0003	Catwalk Floor Support	16
GT1-0005	Catwalk Vertical Support	16
GT1-0006	Catwalk Diagonal Support	16
GT1-0007	Catwalk Splice Plate	16
GT1-0162	Catwalk Support Clip	32
GT1-0310	Large Floor Plank	16
GT1-0311	Medium Floor Plank	16
GT1-0312	Small Floor Plank	16
GT1-0313	Outer Toeboard	16
GT1-0314	Inner Toeboard	16
GT1-0315	Inner Catwalk Handrail	32

Quantity is for one (1) inside catwalk.

Platform

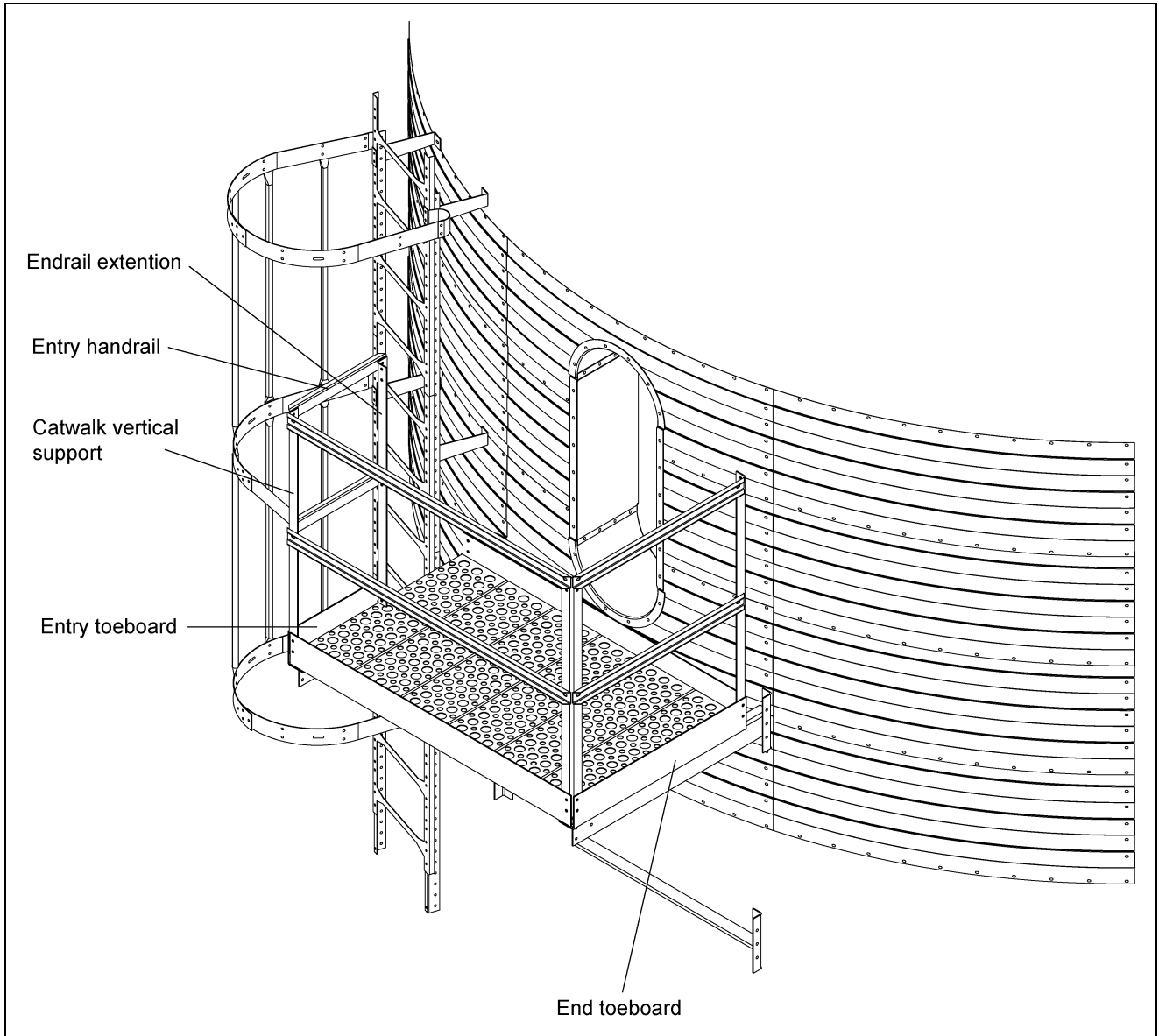

Figure 10C

NOTE: *Safety cage tubing not shown for clarity.*

Outside Catwalk and Inside Catwalk Positions - Model 2500

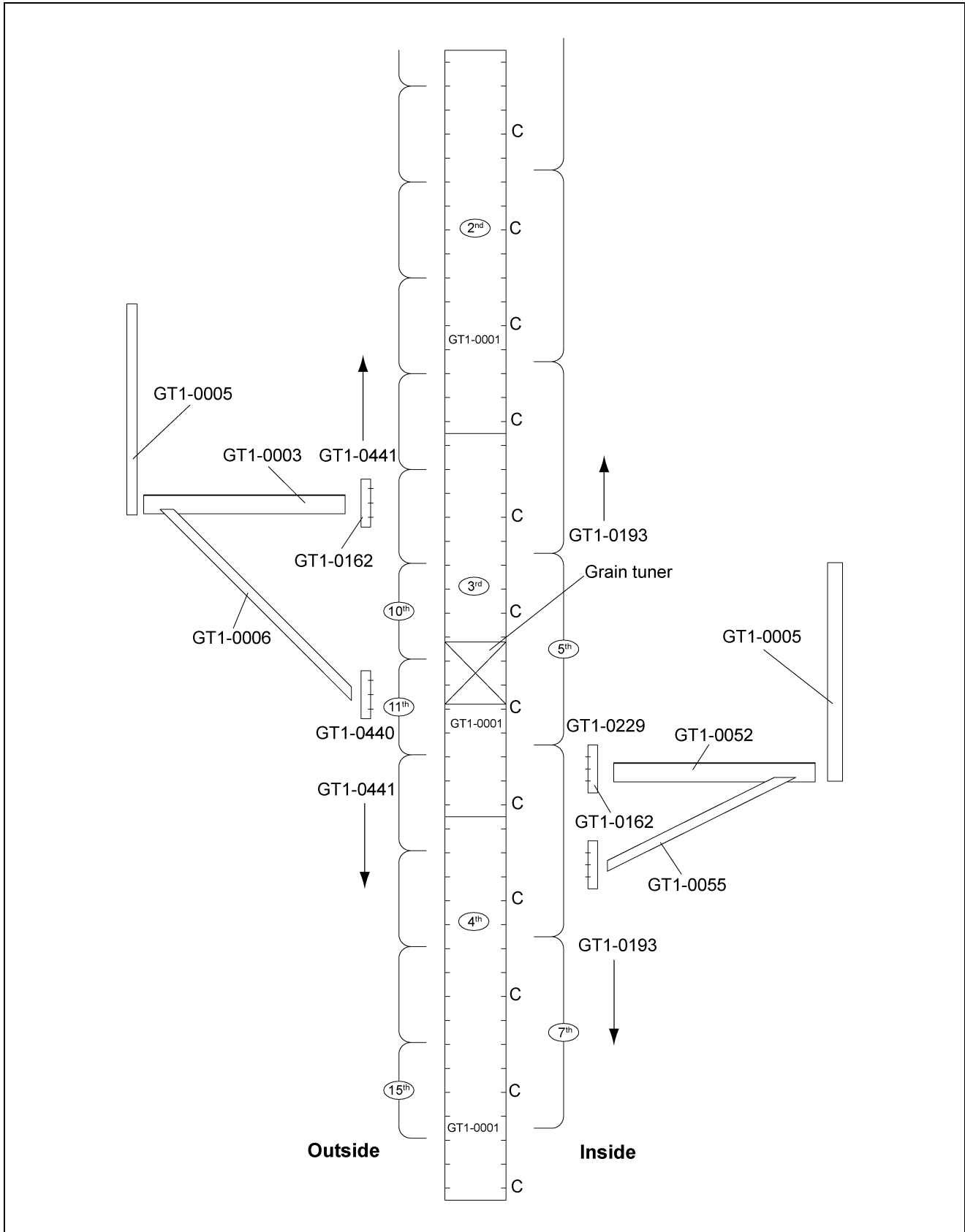

Figure 10D

First Outside Catwalk Position - Model 3000

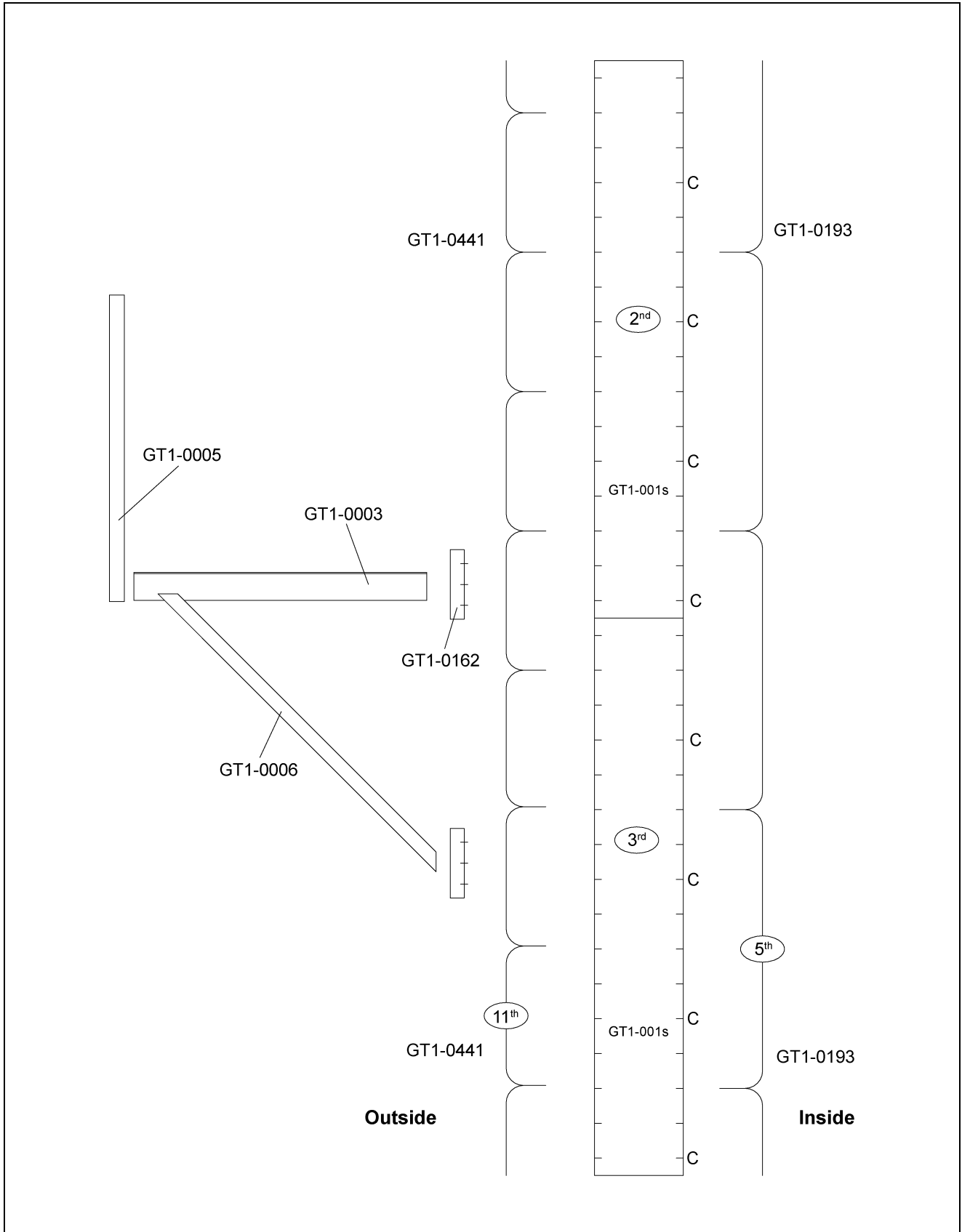

Figure 10E

Second Outside Catwalk and Inside Catwalk Positions - Model 3000

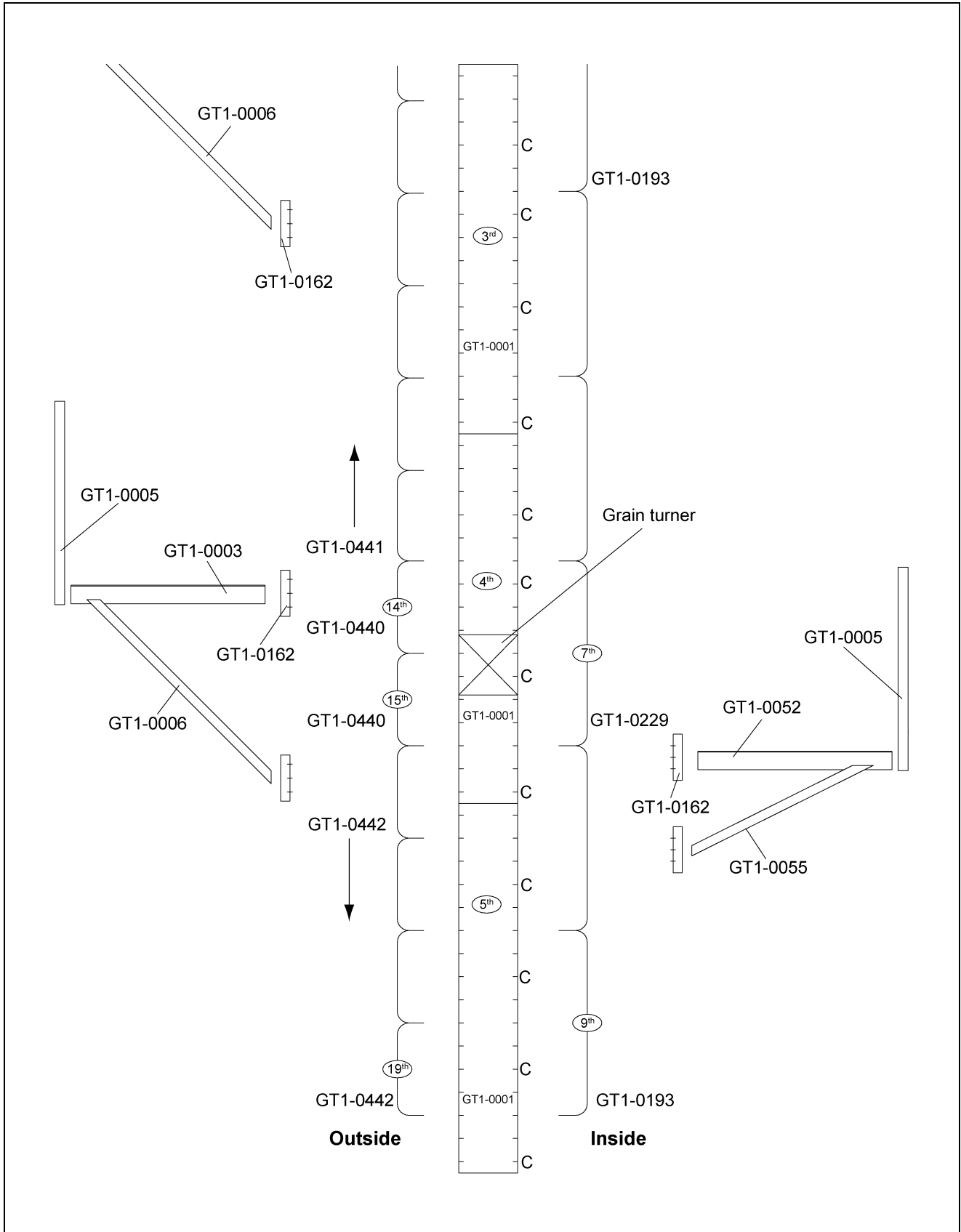

Figure 10F

First Outside Catwalk Position - Model 3500

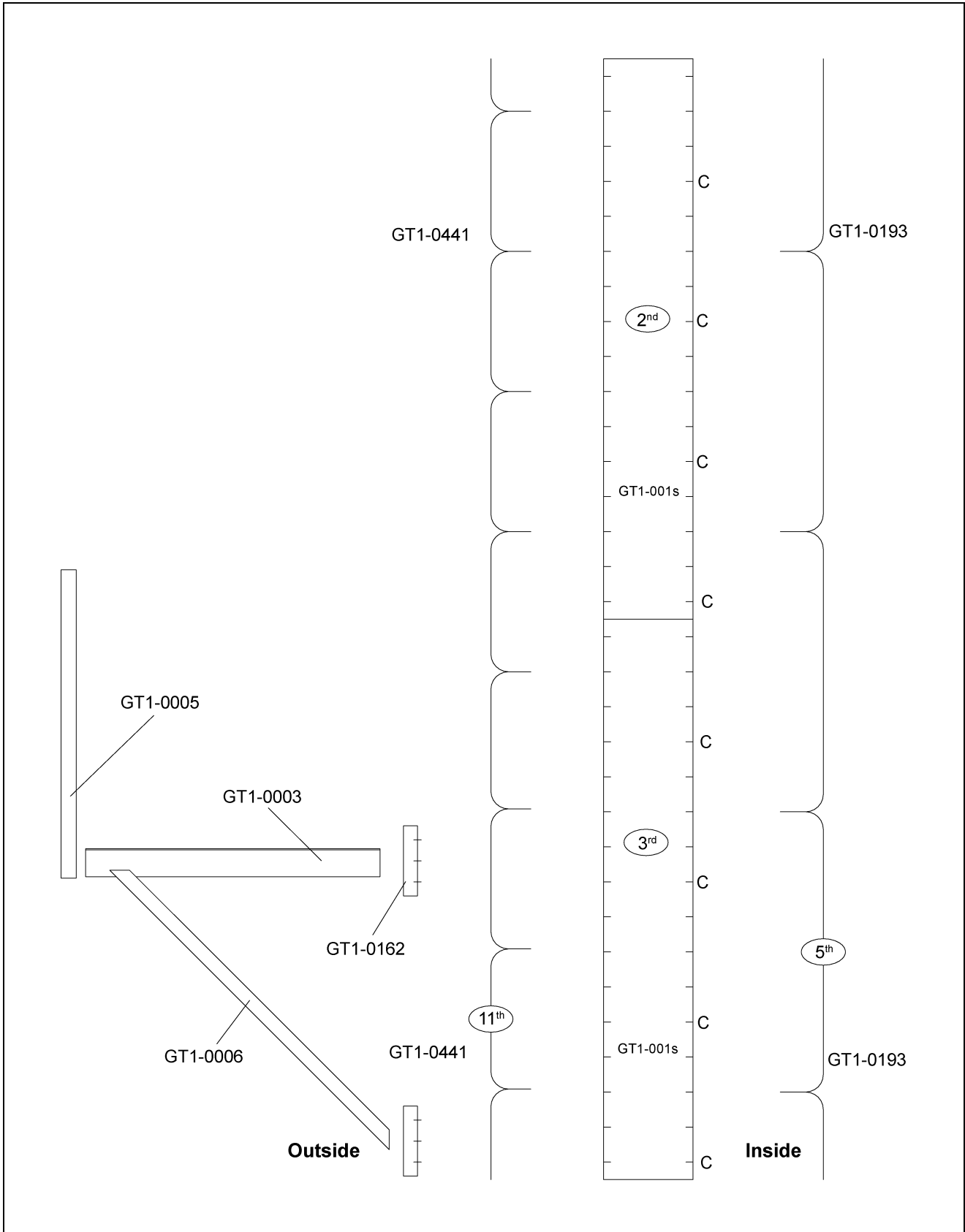

Figure 10G

Second Outside Catwalk and Inside Catwalk Positions - Model 3500

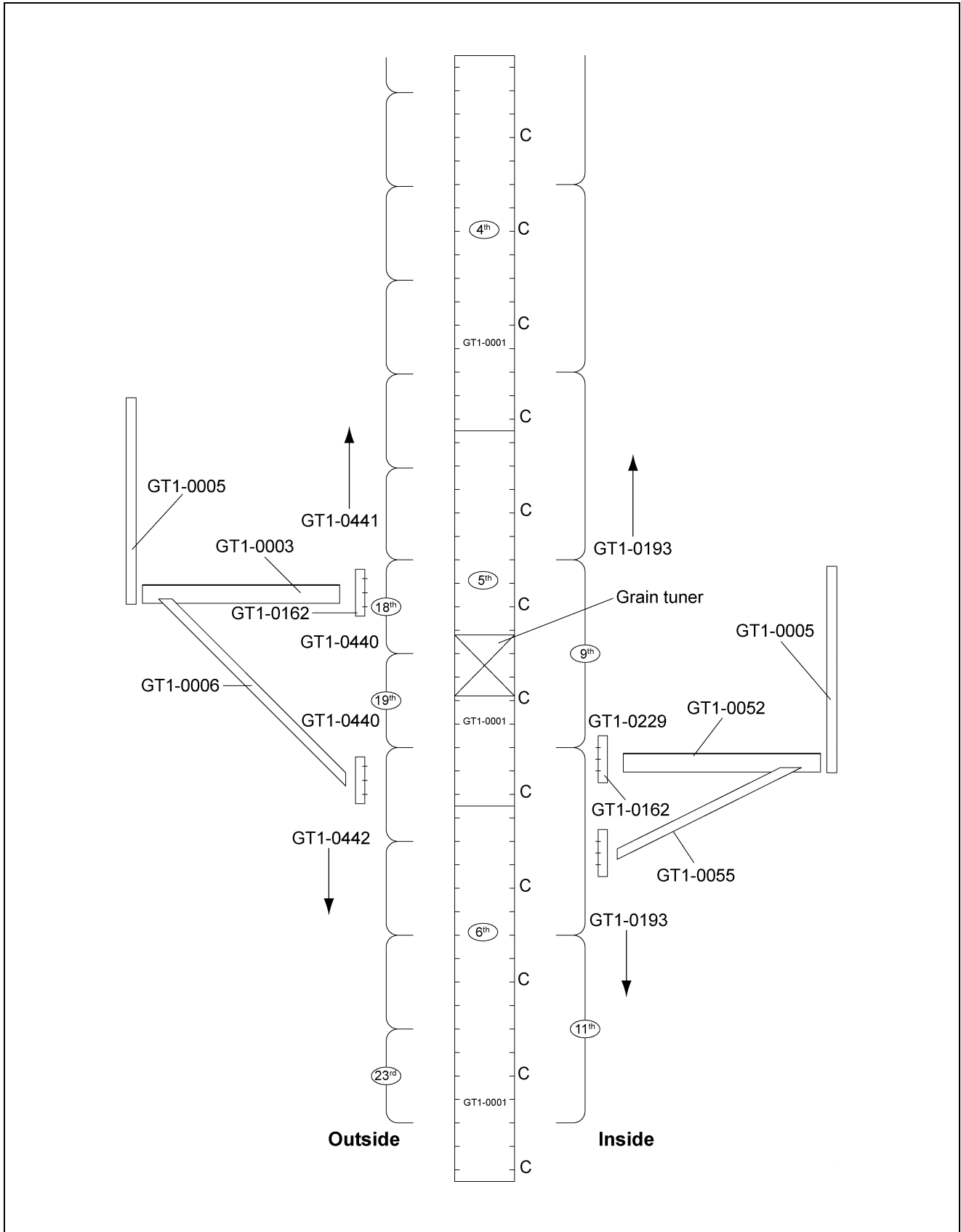

Figure 10H

First Outside Catwalk Position - Model 4000

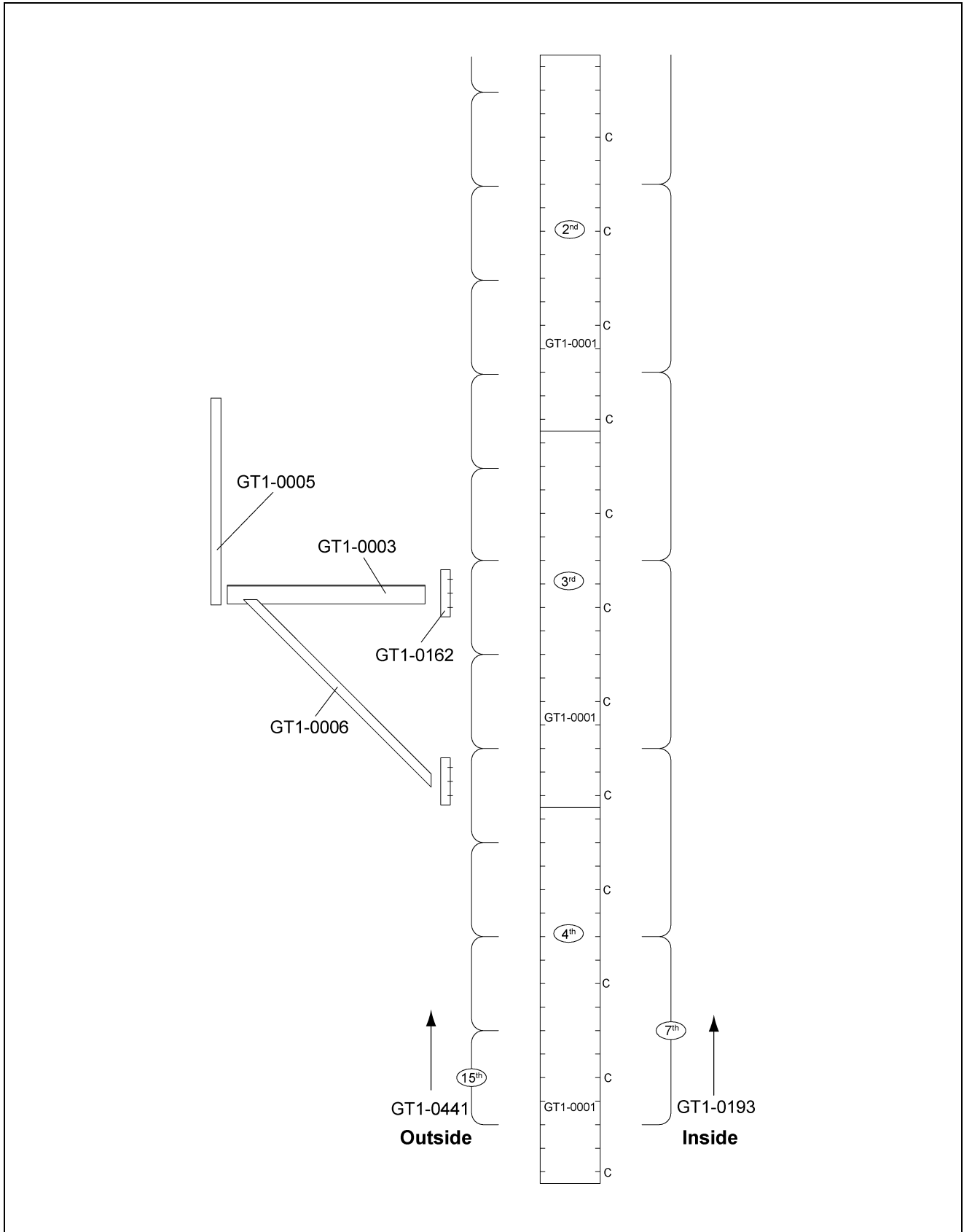

Figure 10I

Second Outside Catwalk and Inside Catwalk Positions - Model 4000

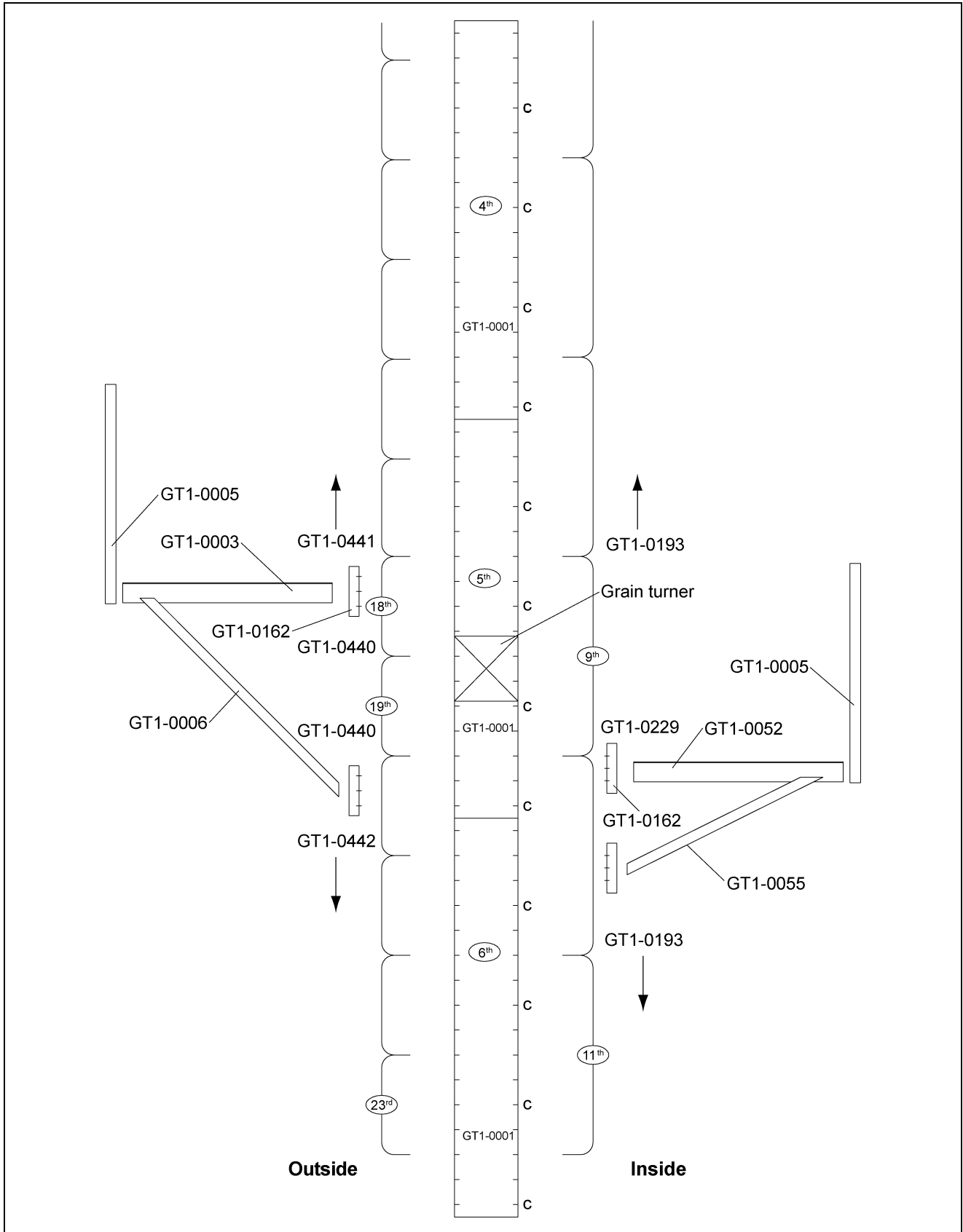

Figure 10J

10. Catwalks and Platforms



Important Safety Precautions:
Dryer has sharp edges. These sharp edges may cause serious injury. Use appropriate personal protective equipment. Use proper lifting techniques.

See [Orientation Section on Page 19](#) for dryer dimensions, components, wall sheet guidelines, etc.
See [Appendix A on Page 435](#) for tools and equipment, [Appendix B on Page 437](#) for hardware, etc.

Steps - Catwalks and Platforms

1. Outside catwalk(s) (one (1) or two (2))
2. Inside catwalk
3. Platforms
 - One (1) Heat Section
 - One (1) Cool Section

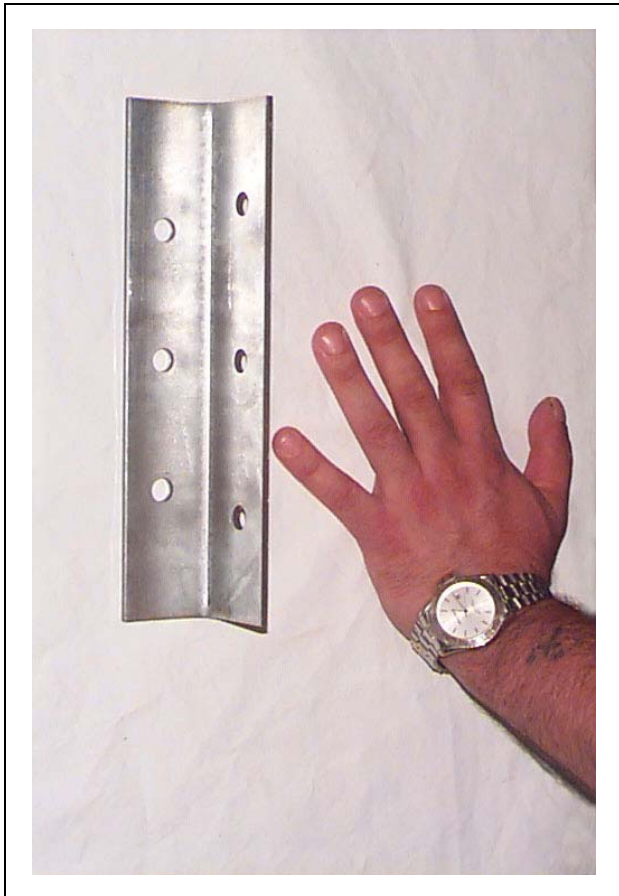

Figure 10K Catwalk support clip is used to install outside catwalk(s), inside catwalk, heat section platform, and cool section platform.



*A. Outside catwalk as shipped
B. Inside catwalk as shipped*

Figure 10L

Outside Catwalk

(* = Door parts)

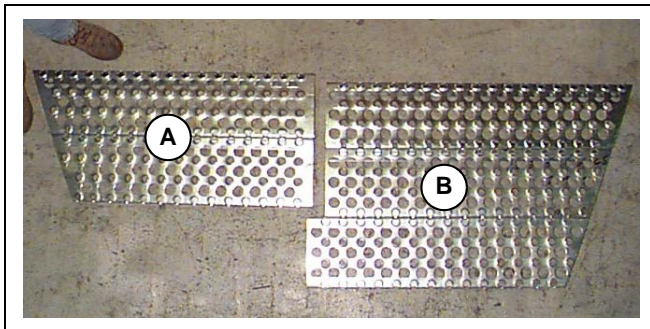

Figure 10M



Figure 10N

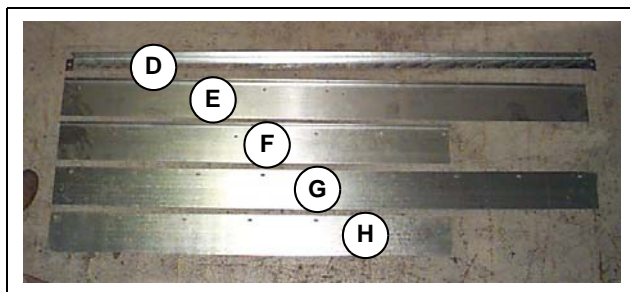

Figure 10O

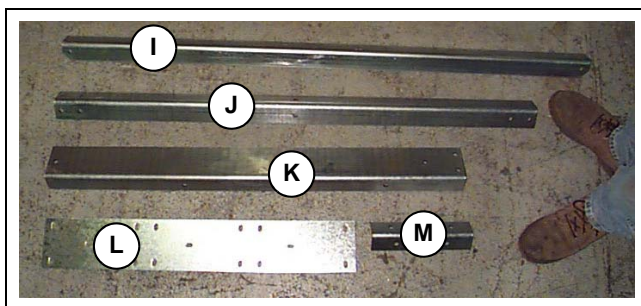

Figure 10P

- A. *Outside catwalk hinged door section
- B. *Outside catwalk door section
- C. Outside catwalk section
- D. Outside catwalk handrail (use for upper and lower handrail)
- E. *Outside catwalk outside door toeboard
- F. *Outside catwalk inside door toeboard
- G. Outside catwalk outside toeboard
- H. Outside catwalk inside toeboard
- I. Outside catwalk diagonal support
- J. Outside catwalk vertical support
- K. Outside catwalk floor support
- L. Outside catwalk splice plate
- M. Catwalk support clip

Outside Catwalk (Continued)

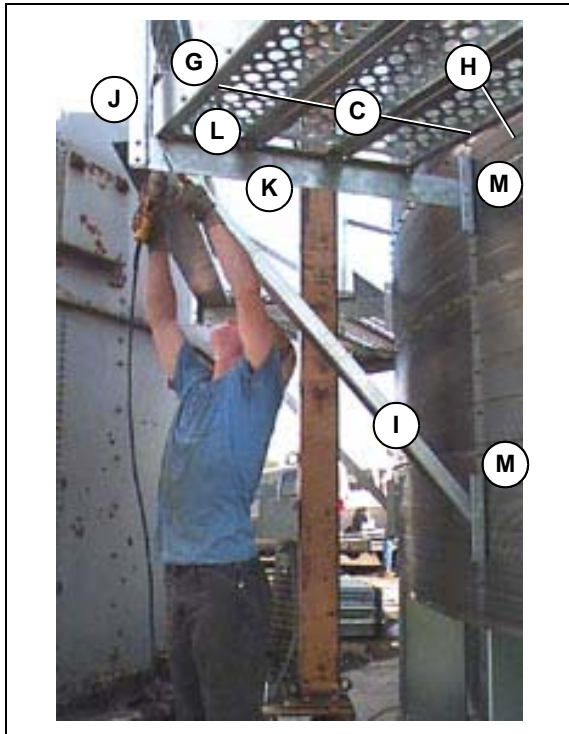

Figure 10Q Parts are listed on [Page 125](#).

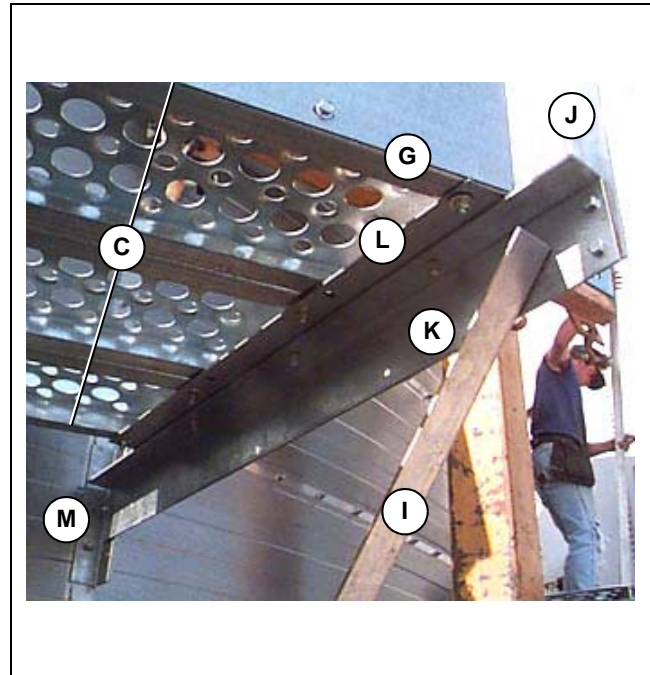

Figure 10R Parts are listed on [Page 125](#).

Use 5/16" x 3/4" whiz lock bolts and nuts to install catwalk flooring.

Use 3/8" x 1" whiz lock bolts and nuts to install handrails and supports.



Figure 10S Catwalk support clip is installed with angle up on R.H. side.

Outside Catwalk (Continued)

1. Snug bolt outside catwalk diagonal support to outside catwalk support clips around perimeter of dryer. Two (2) catwalk support clips were installed on each vertical channel as wall sheets were installed.
2. Pre-assemble outside catwalk door (see Figure 10T) as follows. (Double nut at **X** for movement of parts.)

Bolt **A** at "**X₁**" to outside catwalk outside door toeboard. Bolt **A** at "**X₂**" to **B**.

Center assembled outside catwalk door between and just below ladder rung. Install.

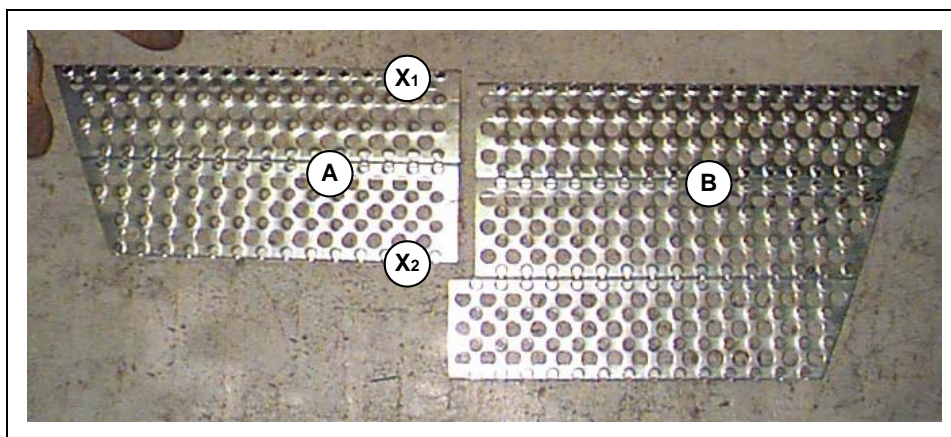

Figure 10T "X" Marks hinge points for outside catwalk door.

3. (On ground) assemble remaining catwalk flooring from outside catwalk section and outside catwalk toeboards.
4. Snug bolt outside catwalk vertical supports to outside catwalk floor supports.
5. Snug bolt upper and lower outside catwalk handrails to catwalk vertical supports.
6. Bolt Outside Catwalk section and lay middle and inside on catwalk and place after above jacks.
7. Check uprights are plumb to the eye. Tighten bolts.
8. Lift dryer.
9. When catwalk is clear of jacks, place remaining catwalk flooring and bolt tight.

NOTE: *If required, install second outside catwalks using the same steps.*

Outside Catwalk (Continued)



Figure 10U Tightening outside catwalk.



Figure 10X Outside Catwalk Door - Open



Figure 10V Tightening outside catwalk bottom handrail.



Figure 10Y Outside Catwalk Door - Closed



Figure 10W Tightening outside catwalk top handrail.



Figure 10Z Completed Outside Catwalks

Inside Catwalk

For inside catwalk door, install provided continuous hinge at "X" to one (1) inside catwalk section.
(See Figure 10AB.)

Use 5/16" x 3/4" whiz lock bolts and nuts to install catwalk flooring.

Use 3/8" x 1" whiz lock bolts and nuts to install handrails and supports.

NOTE: Install inside catwalk parts in the same order as outside catwalk parts.

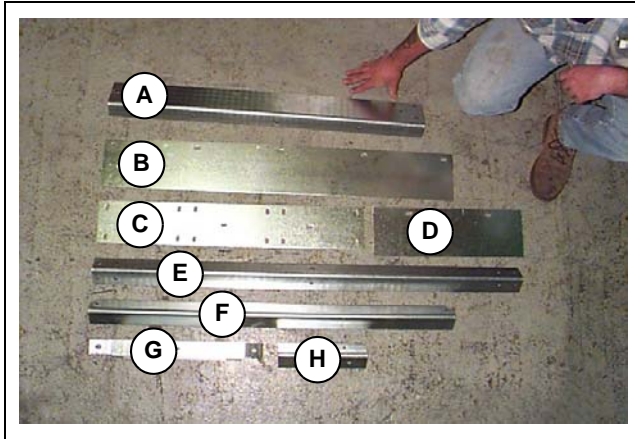

Figure 10AA



Figure 10AC Catwalk support clip is installed with angle up on R.H. side.

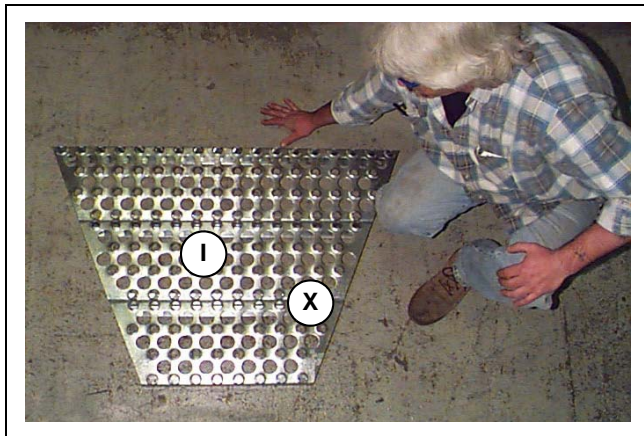

Figure 10AB Inside catwalk section. Also use for inside catwalk door by hinging at "X".

- A. Inside catwalk floor brace
- B. Inside catwalk outside toeboard
- C. Inside catwalk splice plate
- D. Inside catwalk inside toeboard
- E. Inside catwalk vertical support
- F. Inside catwalk diagonal support
- G. Inside catwalk handrail
- H. Catwalk support clip
- I. Inside catwalk section

Inside Catwalk (Continued)

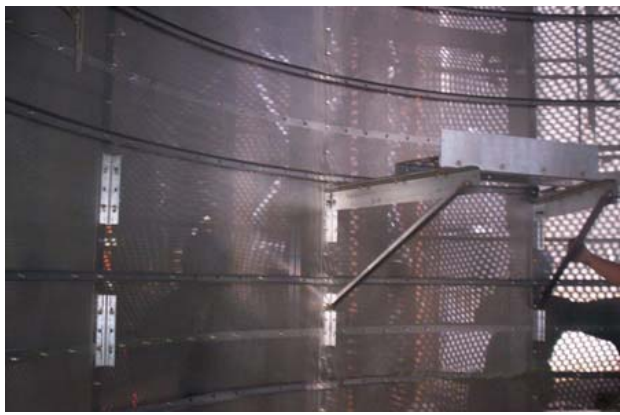

Figure 10AD *Installing inside catwalk.*



Figure 10AF *Bolting inside catwalk splice plate to inside catwalk section.*



Figure 10AE *Bolting inside catwalk vertical support to inside catwalk section.*



Figure 10AG *View from below - Completed inside catwalk.*

Inside Catwalk (Continued)

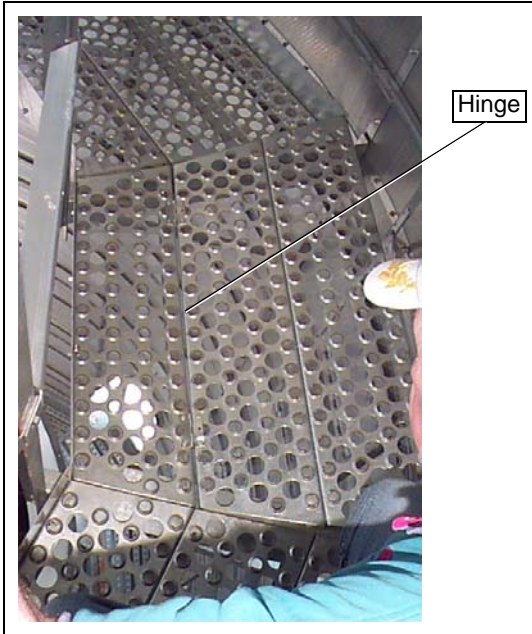

Figure 10AH View from above - Inside catwalk door closed.

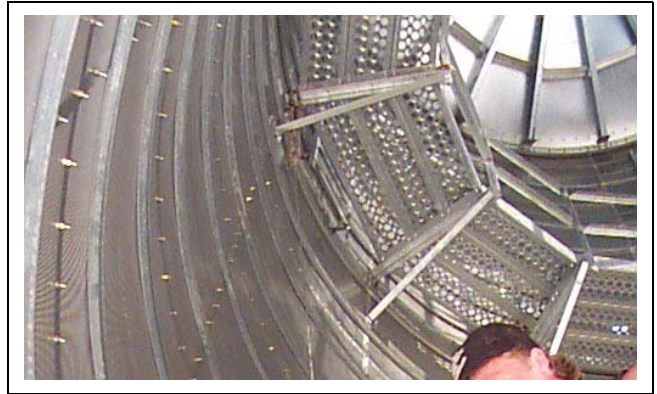

Figure 10AJ View from below - Inside catwalk installed. (Inside catwalk door is closed.) (Ladder is not complete.)



Figure 10AI View from above - Inside catwalk door open.



Figure 10AK View from below - Inside Catwalk installed. (Inside catwalk door is open.)

10. Catwalks and Platforms

Platforms

See flat layouts in [Orientation Section on Page 32](#) for placement of platforms.

[See Figure 10C on Page 116](#) for platform.

Use 5/16" x 3/4" whiz lock bolts and nuts.

1. For each platform, install two (2) sections of catwalk flooring (with toeboards, diagonal supports, vertical supports, and handrails.)
2. Bolt entry toeboard and end toeboard to catwalk flooring.
3. Bolt additional catwalk vertical support (at dryer) to horizontal catwalk support.
4. Bolt two (2) end handrails between catwalk vertical supports.
5. Bolt entry handrail extension to entry toeboard.
6. Bolt two (2) entry handrails to entry handrail extension and catwalk vertical support.
7. Bolt safety cage hoops to platform entry handrail extensions.

Check that all connections are made, and bolts are tight.

Additional Parts

One (1) entry toeboard

One (1) end toeboard

Two (2) end handrail

Two (2) entry handrail

One (1) handrail extension



Important Safety Precautions:
 Dryer has sharp edges. These sharp edges may cause serious injury.
 Use appropriate personal protective equipment. Use proper lifting techniques.

See [Orientation Section on Page 19](#) for dryer dimensions, components, wall sheet guidelines, etc.
 See [Appendix A on Page 435](#) for tools and equipment, [Appendix B on Page 437](#) for hardware, etc.

Four (4) Auxiliary Ladders Burner Housing Ladder

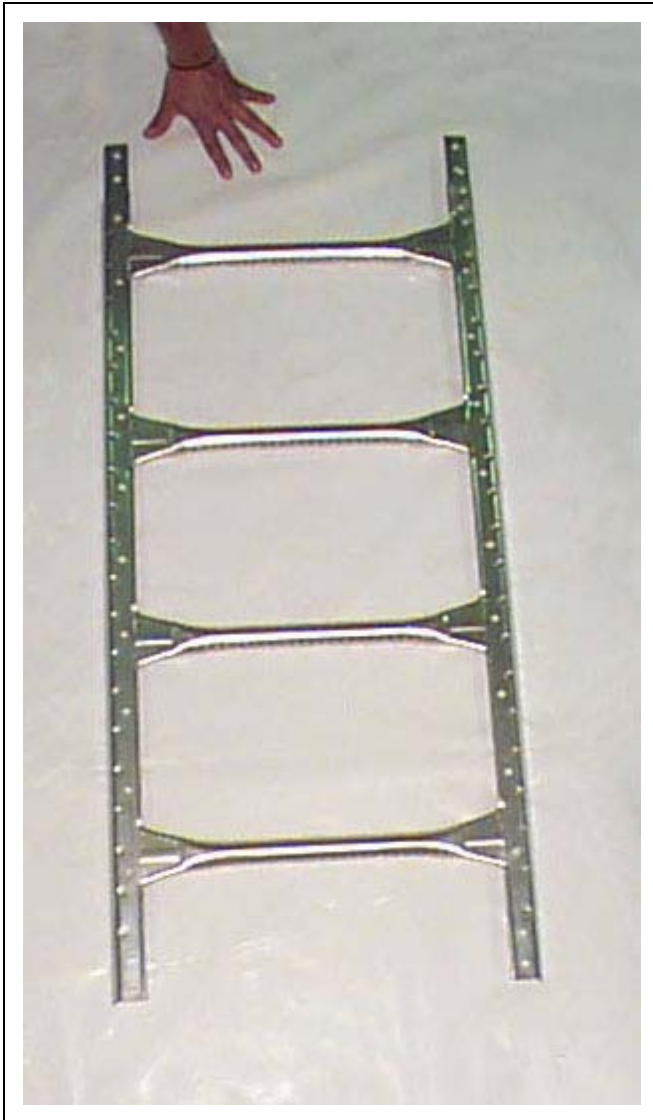
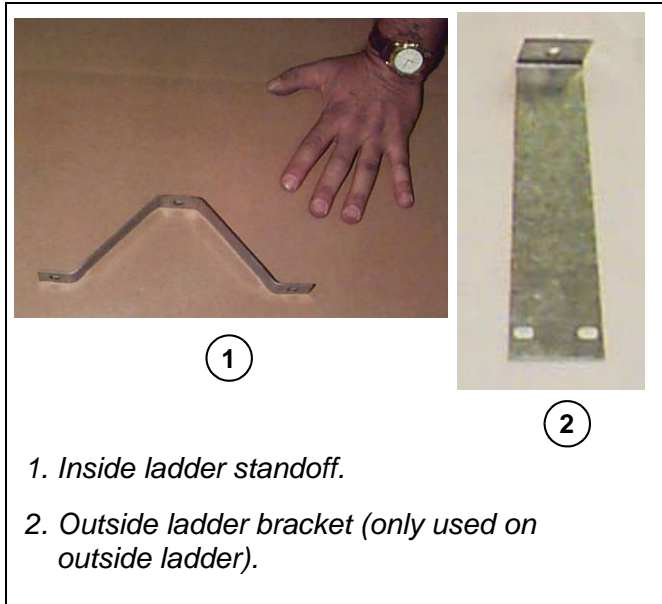

Figure 11A 44" Formed Ladder Section



1. Inside ladder standoff.
2. Outside ladder bracket (only used on outside ladder).

Figure 11B



Figure 11C Close Up - Inside ladder standoff.

Four (4) Auxiliary Ladders (Optional)

Install four (4) auxiliary ladders to inside wall sheets as follows.

Use existing 5/16" x 3/4" galvanized whiz lock bolts and nuts. Prior to installation, verify tightness. **Double nut** with second 5/16" whiz lock nut.

1. Bolt first two (2) inside ladder standoffs on the horizontal seam between the top inside wall sheets. Start in 4th bolt hole left or right from edge of sheet. *(See Figure 11E on Page 135.)*
2. Bolt 4th bolt holes in 44" formed ladder section to inside ladder standoffs. *(See Figure 11B on Page 133.)*
3. Bolt next pair of inside ladder standoffs on next horizontal seam down (directly below first pair). Join next 44" formed ladder section to first and bolt to inside ladder standoffs.
4. Install remaining three (3) auxiliary ladders on every third vertical channel around inside wall of dryer.
5. Repeat steps to continue installing sections of four (4) auxiliary ladders as dryer sections are completed.



Install all 44" formed ladder sections so rungs with rough, textured side for gripping are on top, so climbers do not slip.

Placement of Four (4) Auxiliary Ladders

Install first auxiliary ladder to left of same vertical channel as outside ladder (directly under roof access port). First auxiliary ladder runs from inside top wall sheets, through inside catwalk, to reducer walkway.

Install remaining three (3) auxiliary ladders on every third vertical channel. They run from inside top wall sheets to inside catwalk.

Auxiliary Ladder (Continued)

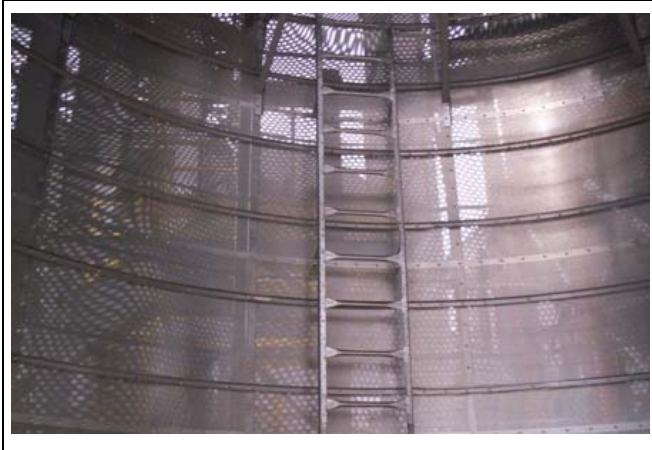

Figure 11D *Installing auxiliary ladder from roof section down.*

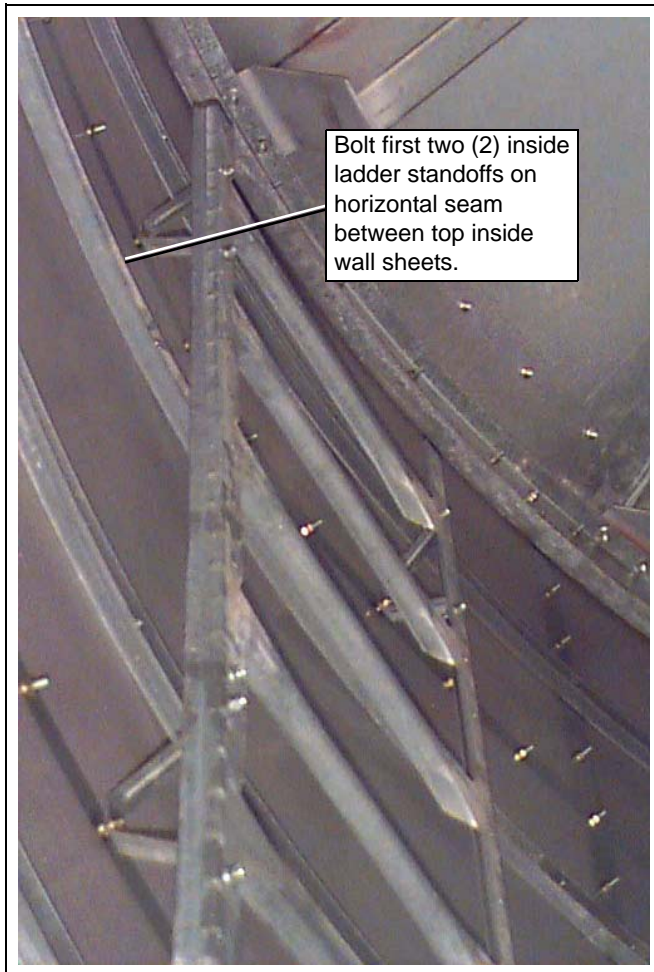

Figure 11E *Close Up - Top of auxiliary ladder.*

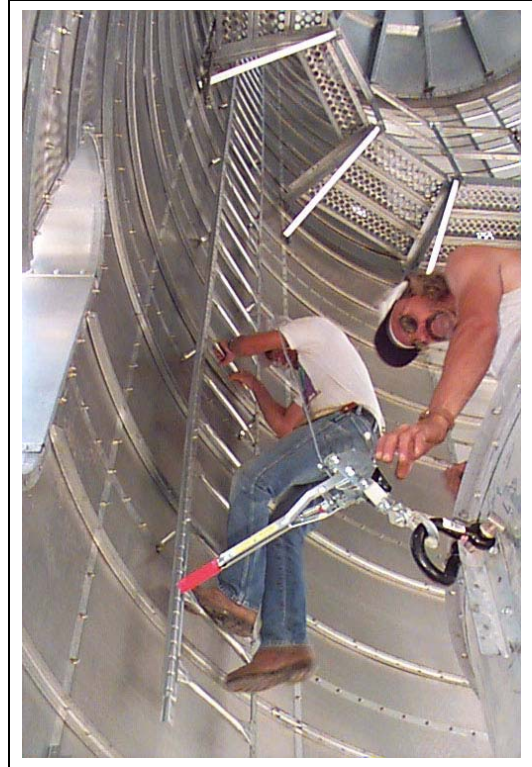

Figure 11F *Installing first auxiliary ladder through inside catwalk.*



Figure 11G *Installing first auxiliary ladder past slide gates - Clean out (grain turners).*

Auxiliary Ladder (Continued)



Figure 11H Auxiliary ladders installed. (2 of 4 shown.)



Figure 11I



Figure 11J

One (1) Burner Housing Ladder

NOTE: *Install burner housing ladder after reducer walkway is complete.*

Drill and use 5/16" x 3/4" galvanized whiz lock bolts and nuts.

1. Install four (4) inside ladder standoffs to first 44" formed ladder section as shown in [Figure 11K](#) and [Figure 11L on Page 138](#), then bolt it to reducer housing.
2. Install four (4) inside ladder standoffs to second 44" formed ladder section, join it to top of first 44" formed ladder section, then bolt to burner housing.



Install all 44" formed ladder sections so rungs with rough, textured side for gripping are on top, so climbers do not slip.

Placement of Burner Housing Ladder

Burner housing ladder gives access to burner. Check to be sure burner housing ladder will top burner housing so it is centered on a corner of burner. Avoid corner of burner with pilot section.

Install burner housing ladder so it is clear of reducer door.



Figure 11K *Bolting inside ladder standoff to 44" formed ladder section.*

Burner Housing Ladder (Continued)



Figure 11L First 44" formed ladder section installed to reducer housing.

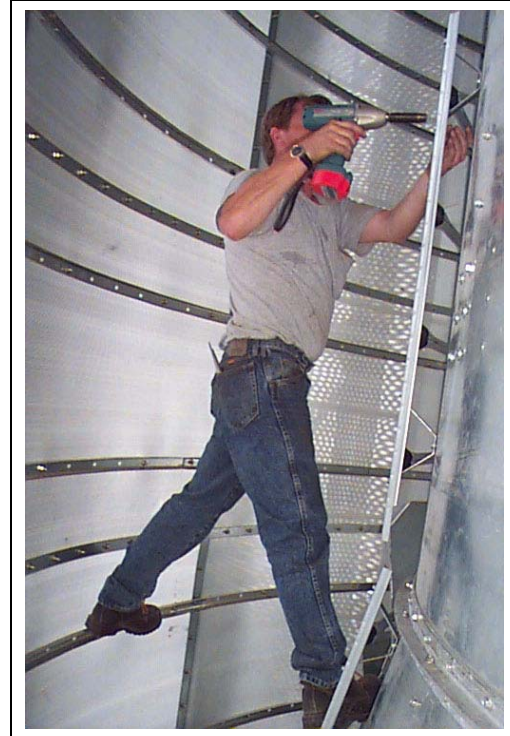

Figure 11M Bolting second 44" formed ladder section to burner housing on opposite side. (For tarping)



Figure 11N Installed burner housing ladder.



Important Safety Precautions:

Dryer has sharp edges. These sharp edges may cause serious injury. Use appropriate personal protective equipment. Use proper lifting techniques.

See [Orientation Section on Page 19](#) for dryer dimensions, components, wall sheet guidelines, etc. See [Appendix A on Page 435](#) for tools and equipment, [Appendix B on Page 437](#) for hardware, etc.

Slide Gates (For Grain Turner Clean Out)

(See [Figure 12A](#) to [Figure 12D](#).)

NOTE: After outside clean out wall sheets with cut outs for slide gates are installed to dryer, install clean out slide gates.

1. Work from outside dryer. Bolt slide gate frame (with open end up), to each cut out in outside clean out wall sheets.

Use 5/16" x 3/4" stainless steel whiz lock bolts, nuts and washers under frame. (Silicone all around frame.)

NOTE: Install 5/16" x 3/4" truss head bolt (inserted into grain column) in bolt holes directly above slide gates. This allows insertion of slide gate plates.

2. Insert slide gate plate in each slide gate frame.

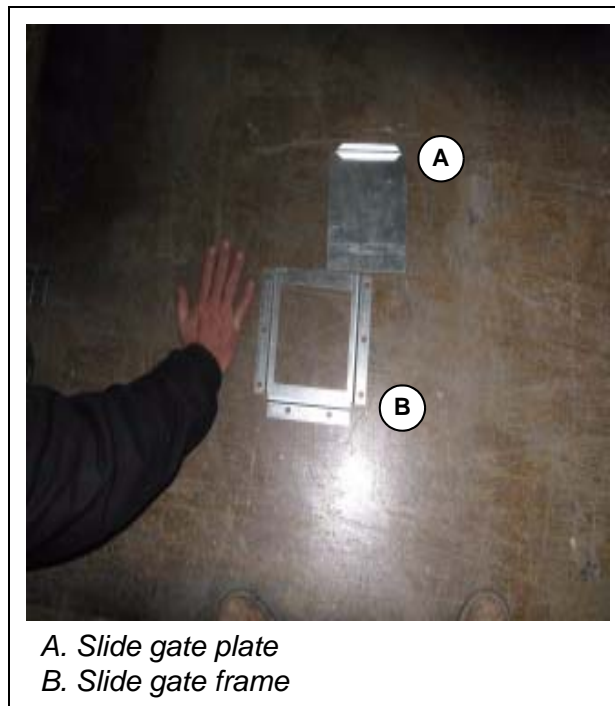

Figure 12A

NOTE: Use same slide gate parts for grain turner clean out and for emergency grain discharge at base of dryer.

12. Slide Gates

Slide Gates at Base of Dryer (For Emergency Grain Discharge)

1. After outside bottom wall sheets (20" solid with cut outs) are installed at base of dryer, install slide gates as in [Page 139](#). (See [Figure 12B](#) and [Figure 12C](#).)
2. After outside hopper panels with cut outs are installed, install slide gates as in [Page 139](#). (See [Figure 12D](#) and [Figure 12E](#).)



Figure 12B Installing slide gate plate to frame on outside bottom wall sheet and mid way sheet. (For emergency discharge and cleaning.)

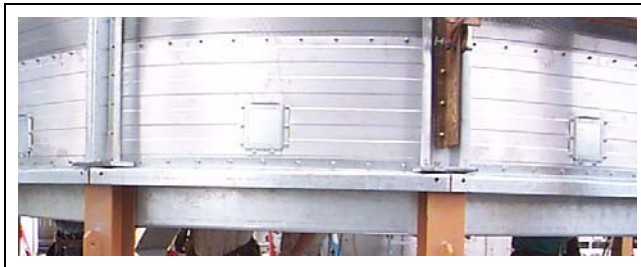

Figure 12C Slide gate installed to outside bottom wall sheet. (For emergency discharge.)



Figure 12D Installing slide gate plate to frame on outside hopper panels. (For emergency discharge.)



Figure 12E Use 5/16" x 3/4" galvanized at hopper clean outs. Slide gate installed to outside hopper panels. (For emergency discharge.)



Important Safety Precautions:

Dryer has sharp edges. These sharp edges may cause serious injury. Use appropriate personal protective equipment. Use proper lifting techniques.

See [Orientation Section on Page 19](#) for dryer dimensions, components, wall sheet guidelines, etc.
See [Appendix A on Page 435](#) for tools and equipment, [Appendix B on Page 437](#) for hardware, etc.

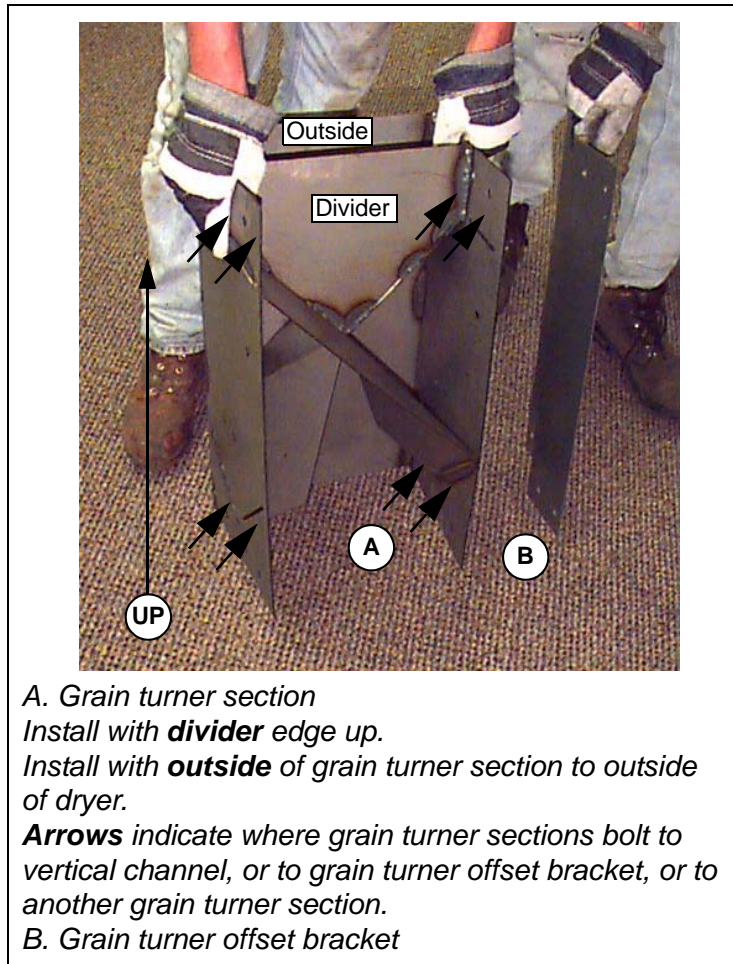

Figure 13A



Figure 13B Close Up - Grain Turner Offset Bracket
(Symmetrical - There is no up or down)

13. Grain Turners

Grain Turners

Install forty eight (48) grain turner sections with twelve (12) grain turner offset brackets as follows.

NOTE: *Four (4) grain turner sections are installed in each grain column make one grain turner.*

Install after inside sheets are installed.

Use 5/16" x 1" galvanized hex head bolts and nuts.

1. Bolt grain turner offset brackets inside vertical channels that face each other [].
Vertical channels that face away from each other] [require no grain turner offset brackets.
2. In each grain column, loosely bolt one (1) outside grain turner section to each vertical channel (or to grain turner offset brackets).
Then loosely bolt one (1) middle grain turner sections to each outside grain turner section.
Then loosely bolt two (2) middle grain turner sections together.
3. Tighten grain turners after all grain turner sections are installed around dryer.
4. Test tightness by firmly tugging grain turners.
5. Install two (2) rows outside wall sheets (20" solid) over grain turners.



Figure 13C *Installing outside grain turner sections.*



Figure 13D *Installing middle grain turner sections.*



Figure 13E *Tightening grain turner sections.*



Figure 13F *Installed grain turners.*

Burner Housing Model 2500/3000/3500

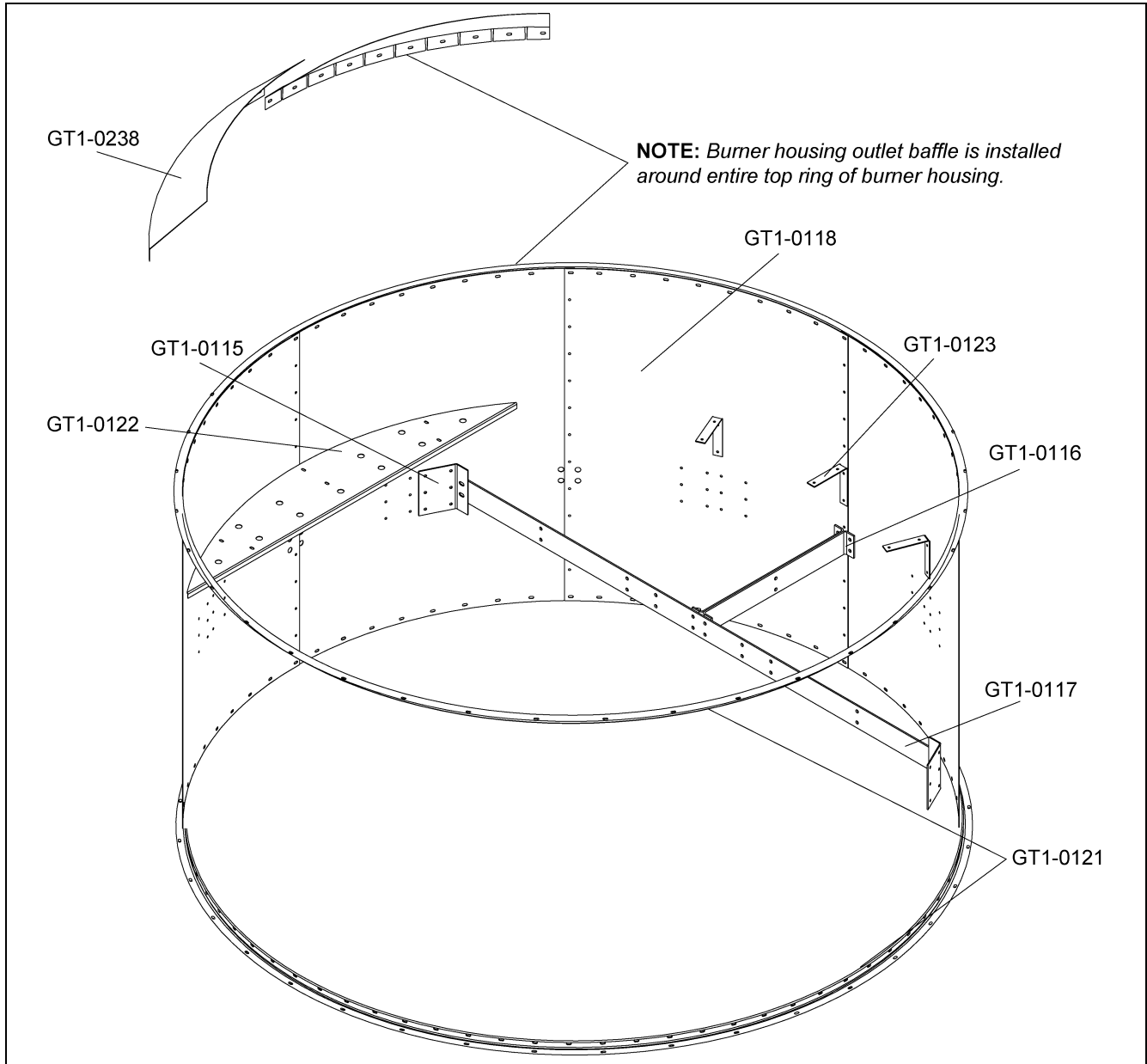

Figure 14A

Part #	Description	Qty
GT1-0115	Burner Mounting Bracket	4
GT1-0116	Burner Support Tee	4
GT1-0117	Burner Support Bracket	4
GT1-0118	Burner Housing Sheet	8
GT1-0121	Burner Angle Rings	3
GT1-0122	Burner Baffle	4
GT1-0123	Burner Baffle Support	12
GT1-0238	Burner Housing Outlet Baffle	8

Burner Housing Model 4000

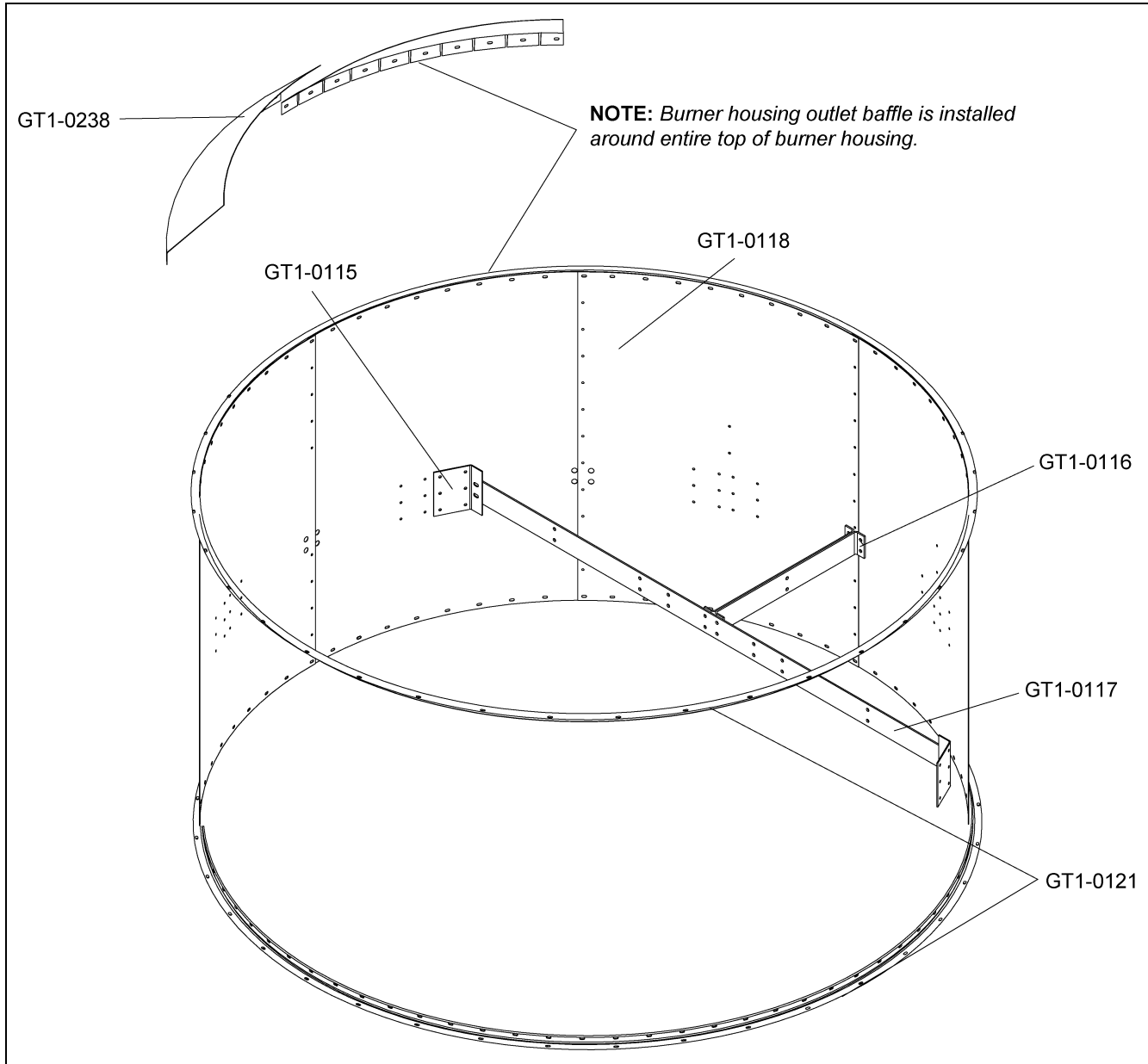

Figure 14B

Part #	Description	Qty
GT1-0115	Burner Mounting Bracket	4
GT1-0116	Burner Support Tee	4
GT1-0117	Burner Support Bracket	4
GT1-0118	Burner Housing Sheet	8
GT1-0121	Burner Angle Rings	3
GT1-0238	Burner Housing Outlet Baffle	8

14. Burner and Reducer



Important Safety Precautions:
*Dryer has sharp edges. These sharp edges may cause serious injury.
Use appropriate personal protective equipment. Use proper lifting techniques.*

See [Orientation Section on Page 19](#) for dryer dimensions, components, wall sheet guidelines, etc.
See [Appendix A on Page 435](#) for tools and equipment, [Appendix B on Page 437](#) hardware, etc.

Burner and Reducer Example: Model 3000

Burner and Burner Housing

NOTE: Burner housing is straight vertical. Reducer is cone shaped to reduce air flow from blowers to burner housing. (See [Figure 14C](#) to [Figure 14F.](#))

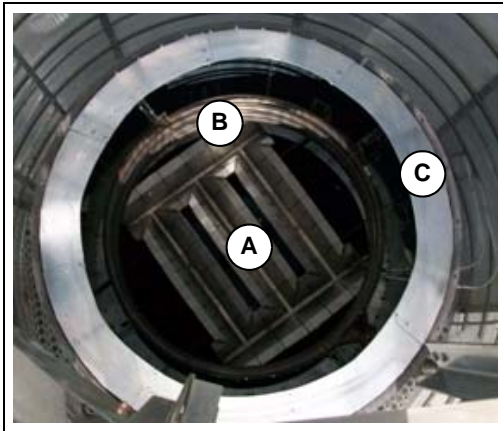

Figure 14C Burner installed inside burner housing.

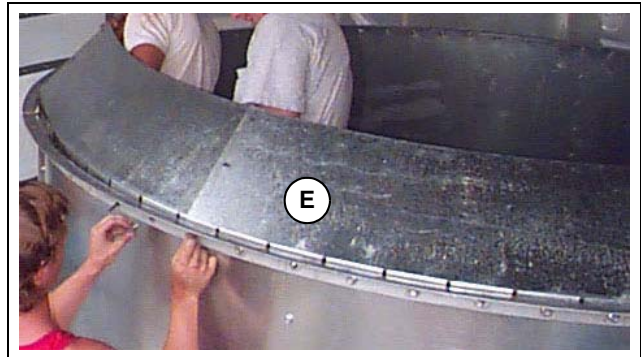

Figure 14E

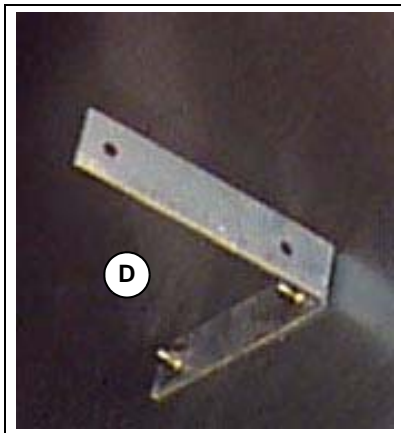

Figure 14D

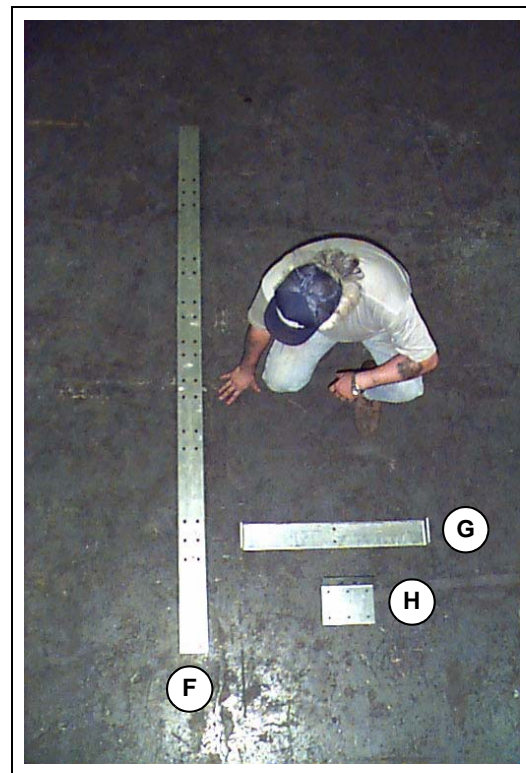

Figure 14F

- A. Burner
- B. Burner baffle
- C. Burner housing
- D. Burner baffle support
- E. Burner housing outlet baffle
- F. Burner support bracket
- G. Burner support tee
- H. Burner mounting bracket

Burner and Burner Housing (Continued)



Figure 14G Install rolled plenum channels across gap to maintain shape and stability. Remove rolled plenum channels when ready to move burner into dryer.

Depending on model, [See Figure 14A on Page 144](#) or [Figure 14B on Page 145](#), burner housing.

[See Orientation Section on Page 32](#) for flat layout for heat section door frame placement.

[See Windows and Doors on Page 187](#) for windows and doors for heat section door and reducer door installation.

1. Remove rolled plenum channels and bring in both halves of burner housing. See illustration for up/down orientation.

Also place burner, burner baffle, and other parts inside burner housing to avoid lifting them in later. (Other parts are burner baffle supports, burner mounting brackets, burner support brackets, and burner support tees).

2. Align and bolt halves of burner housing. Use 5/16" x 1" galvanized whiz lock bolts and nuts.
3. Overlap and bolt sections of burner housing outlet baffle to top ring of burner housing. Use 5/16" x 1" galvanized whiz lock bolts and nuts.
4. Check orientation of burner pilot section (with installation points for ignitor and flame sensor). Plan to install burner so pilot section wiring will make direct run (usually through motor window to control box.)
5. Measure to determine correct bolt hole knock-outs for burner support parts. Knock out bolt holes as required.
6. Install burner to burner housing as follows.
 - a. Loosely bolt four (4) burner mounting brackets to burner housing. Bracket them (orient as mirror images). Use 3/8" x 1" galvanized bolts, nuts. Install washers on outside of burner housing.
 - b. Lift and temporarily support burner while installing burner support brackets below burner. Loosely bolt two (2) burner support brackets to burner mounting brackets. Use 1/2" x 1-1/2" galvanized bolts and nuts. Position burner over burner support brackets.

14. Burner and Reducer

Burner and Burner Housing (Continued)

c. Loosely bolt pairs of burner support tees (back to back) to burner housing. Use 1/2" x 1-1/2" bolts, nuts. Install washers on outside of burner housing.

Loosely bolt burner support tees to burner support brackets. Use 1/2" x 1" bolts and nuts.

d. Bolt burner support clips (already on burner manifold) to burner support brackets. Use 1/2" x 1" bolts and nuts.

e. Tighten all bolts.

7. Models 2500/3000/3500:

Bolt burner baffle supports to burner housing. Bolt burner baffles to burner baffle supports. Use 5/16" x 3/4" bolts and nuts.

NOTE: Fuel piping will be installed in later step.

NOTE: After reducer walkway is installed, 44" ladder sections will be installed to outside of burner housing and reducer.



Figure 14H Moving burner, burner baffles and other parts inside burner housing.



Figure 14J Installing burner housing outlet baffle to top rim of burner housing.



Figure 14I Bolting together halves of burner housing.



Figure 14K Close up inside burner housing - Installing burner housing outlet baffle to top rim of burner housing.

Burner and Burner Housing (Continued)

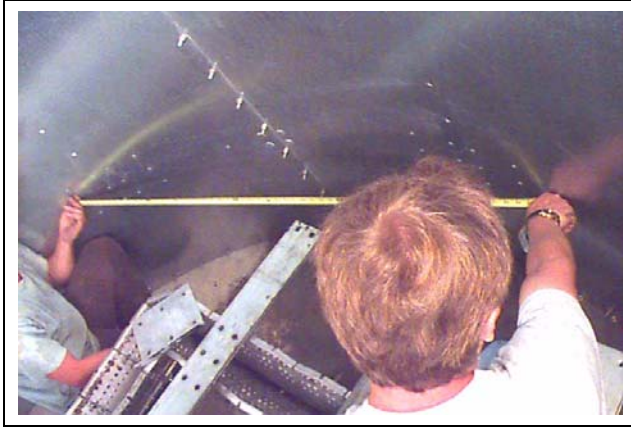

Figure 14L *Measuring to determine correct knock-outs for bolt holes.*

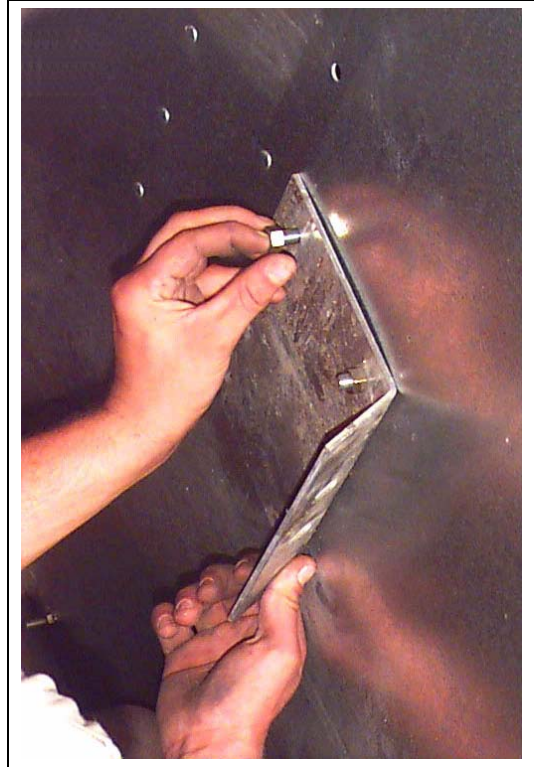

Figure 14N *View inside burner housing - Installing burner mounting bracket.*



Figure 14M *Knocking out bolt holes for burner mounting bracket. (May be pre-drilled at factory also.)*



Figure 14O *View outside burner housing - Installing burner mounting bracket with washers.*

Burner and Burner Housing (Continued)



Figure 14P *First burner support bracket installed to burner mounting bracket.*

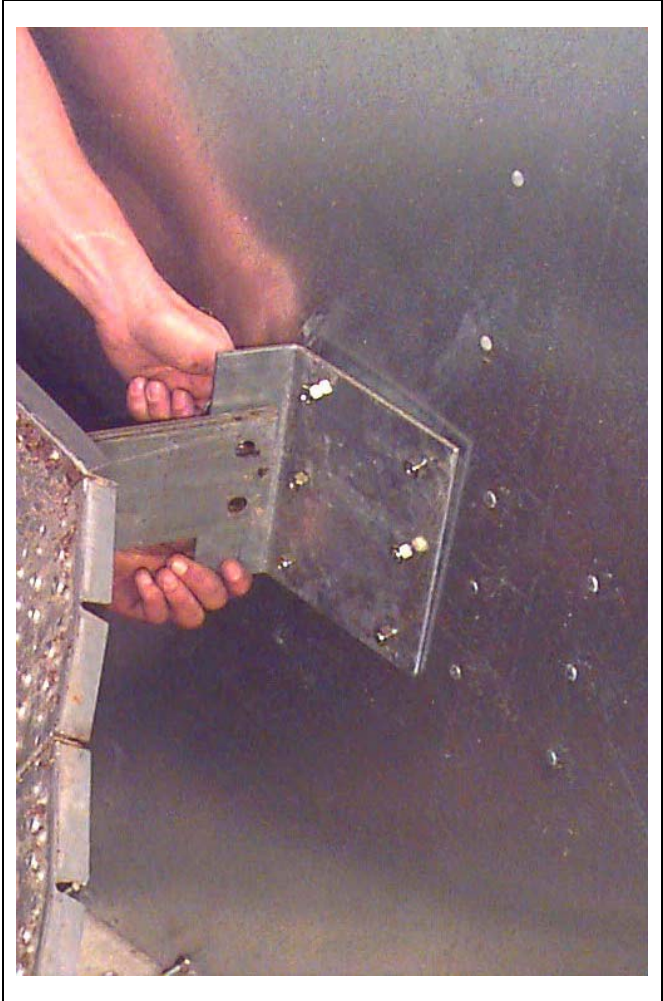

Figure 14R *Close Up - Installing burner support bracket to burner mounting bracket.*



Figure 14Q *Installing second burner support bracket to burner mounting brackets.*



Figure 14S *Installing a pair of burner support tees (back to back) to burner housing.*

Burner and Burner Housing (Continued)

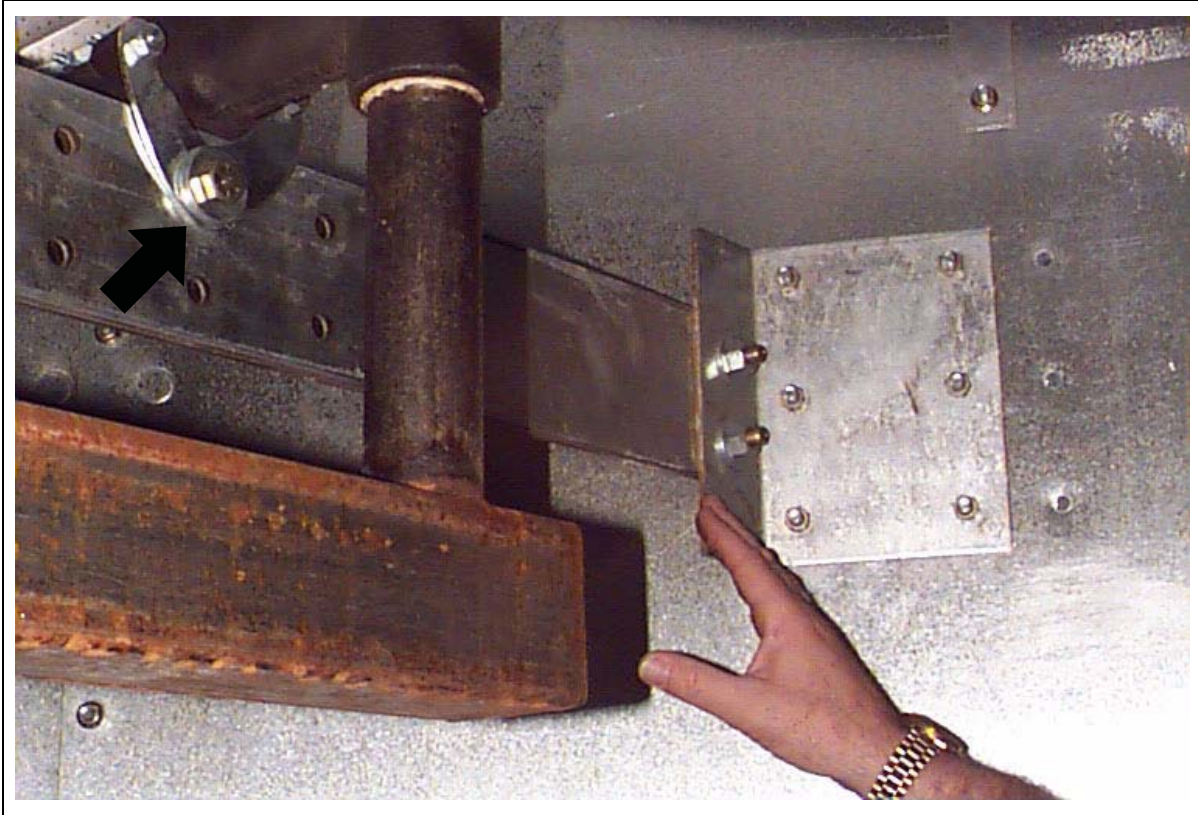

Figure 14T Burner support bracket bolted to burner support clip (arrow).

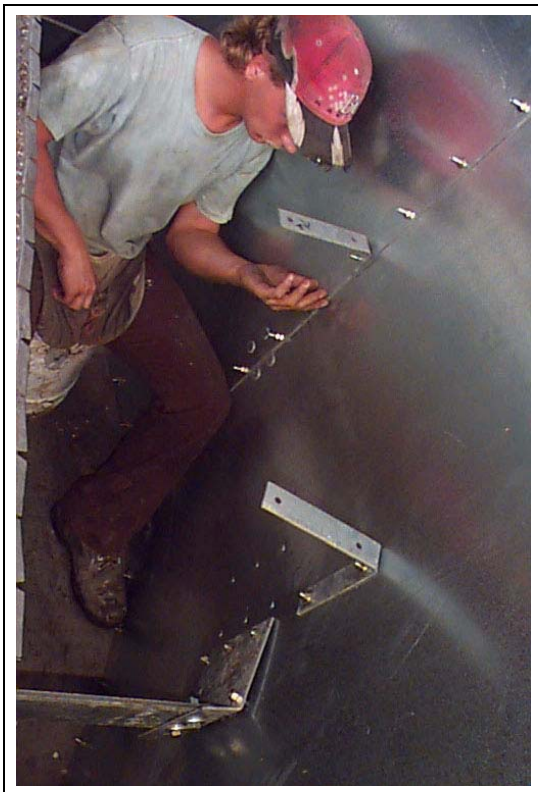

Figure 14U Installing burner baffle supports.



Figure 14V Installing burner baffles.

Reducer

1. Lift burner/burner housing. Move both halves of reducer into dryer and under burner housing.
Orient reducer door cut out so it faces same vertical channel as heat section burner door. This will ensure maximum light for entering completed reducer area.
On completed dryer, burner will be accessed through reducer door. Orient pre-cut opening for reducer door so it will give easy access to reducer by stepping onto top of a fan or fan splicing.
2. Bolt side seams of reducer.
Use 5/16" x 1" whiz lock bolts and nuts.
Align and bolt reducer to burner housing.
Lift reducer 1" or 2" and bolt together bottom rim of reducer halves.

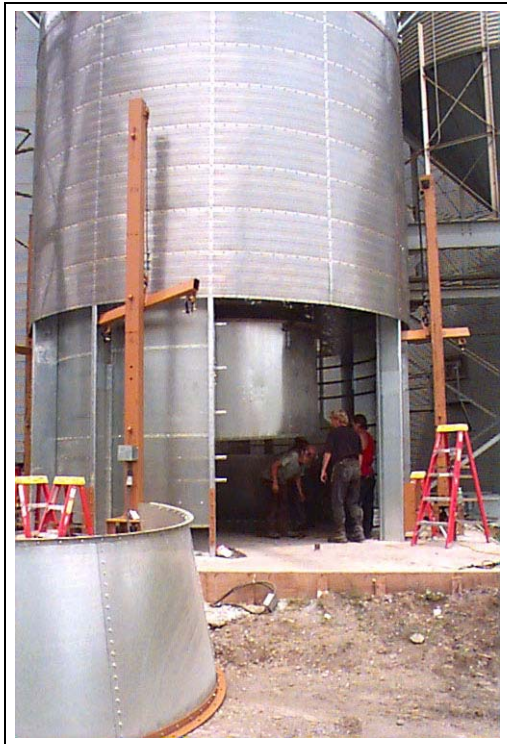

Figure 14W Remove rolled plenum channels, and lift burner/burner housing to provide access for reducer.



Figure 14Y Orient reducer door cut out so it faces same vertical channel as heat section burner door.



Figure 14X Move reducer under burner housing.



Figure 14Z Bolting halves of reducer together.



Figure 14AA Close Up - Bolting sections of reducer ring together.



Figure 14AB Aligning and bolting reducer to burner housing.



Figure 14AC Close Up - Bolting reducer to burner housing.

Fan Splicing and Reducer Walkway - All Models

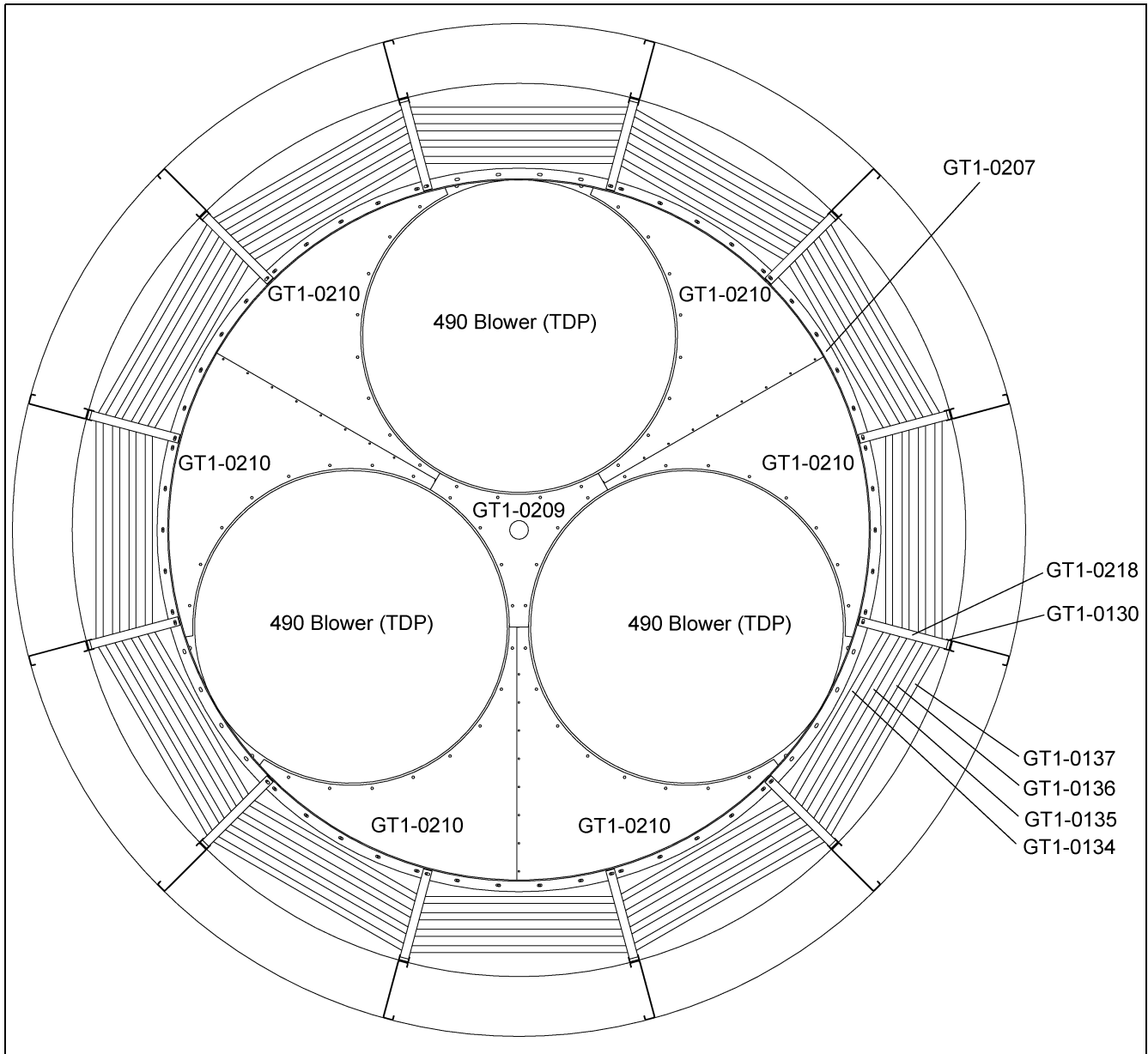

Figure 15A

Part #	Description	Qty
GT1-0130	Reducer Walkway Support Clip	12
GT1-0134	Reducer Walkway Slat #3	12
GT1-0135	Reducer Walkway Slat #4	12
GT1-0136	Reducer Walkway Slat #5	12
GT1-0137	Reducer Walkway Slat #6	12
GT1-0207	Reducer Angle Ring 490	1
GT1-0209	Blower Housing Splice 490	1
GT1-0210	Blower Reducer Panel 490	6
GT1-0218	Reducer Walkway Support Beam 490	12

Fan X-Bracing - All Models

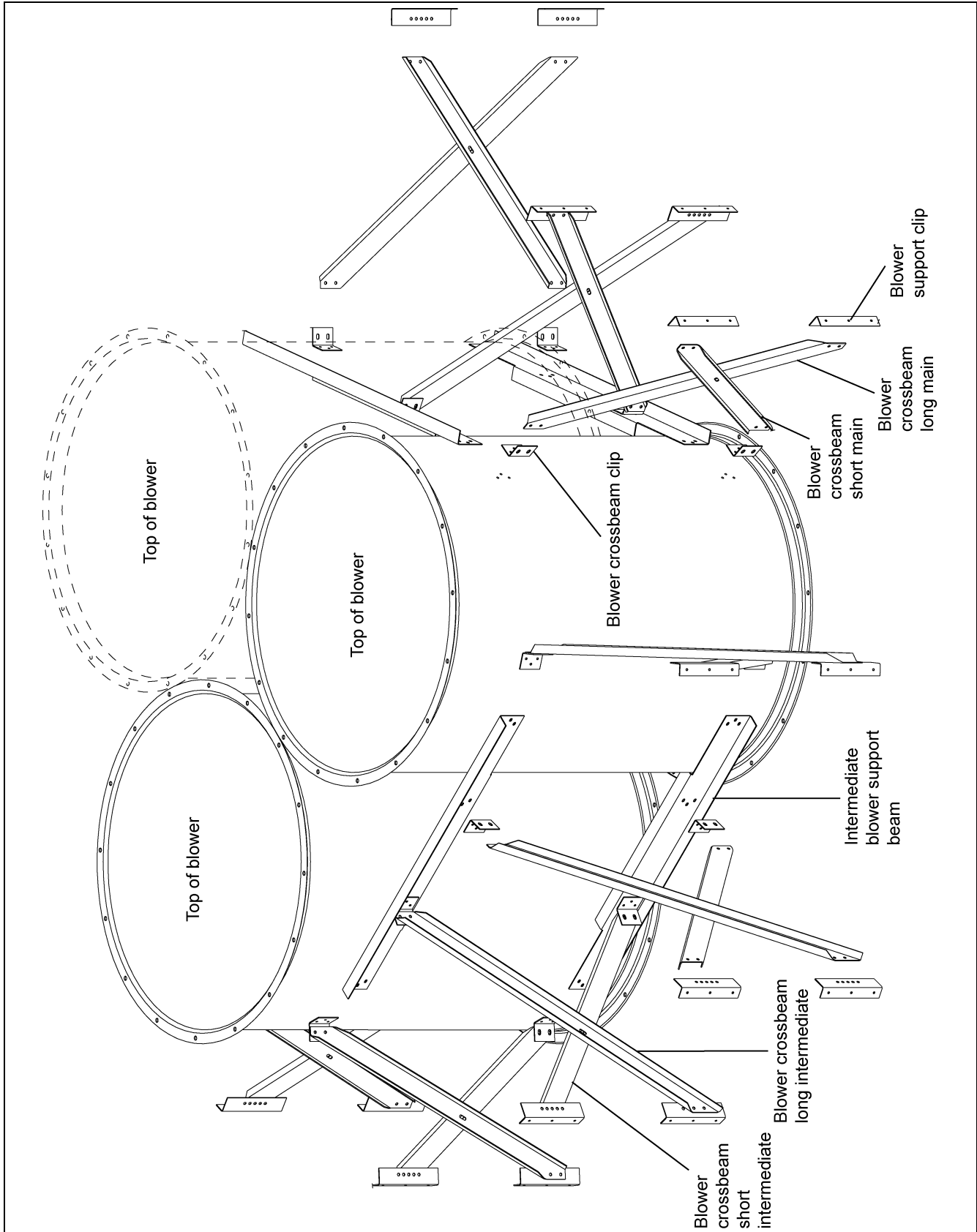

Figure 15B

Fan X-Bracing, Divider Hopper, and Reducer Walkway Model 2500

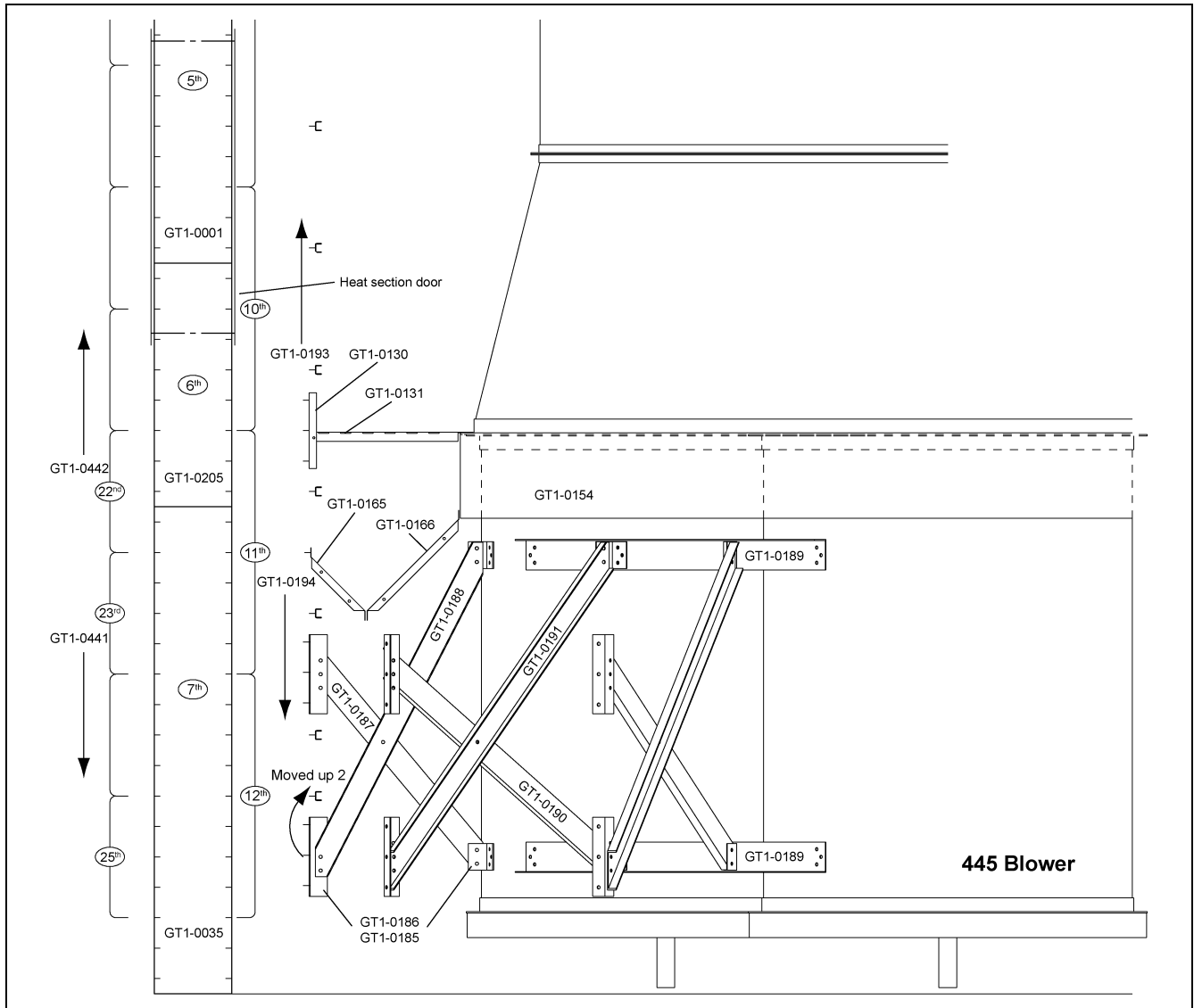

Figure 15C

Part #	Description	Qty
GT1-0130	Reducer Walkway Support Clip	12
GT1-0131	Reducer Walkway Support Beam 445	12
GT1-0154	Blower Skirting 445	4
GT1-0165	Outer Divider Hopper	12
GT1-0166	Inner Divider Hopper 445	12
GT1-0185	Blower Support Clip	24
GT1-0186	Blower Crossbeam Clip	24
GT1-0187	Blower Crossbeam Short Main 445	6
GT1-0188	Blower Crossbeam Long Main 445	6
GT1-0189	Intermediate Blower Support Beam 445	6
GT1-0190	Blower Crossbeam Short Intermediate 445	6
GT1-0191	Blower Crossbeam Long Intermediate 445	6

Fan X-Bracing, Divider Hopper, and Reducer Walkway Model 3000

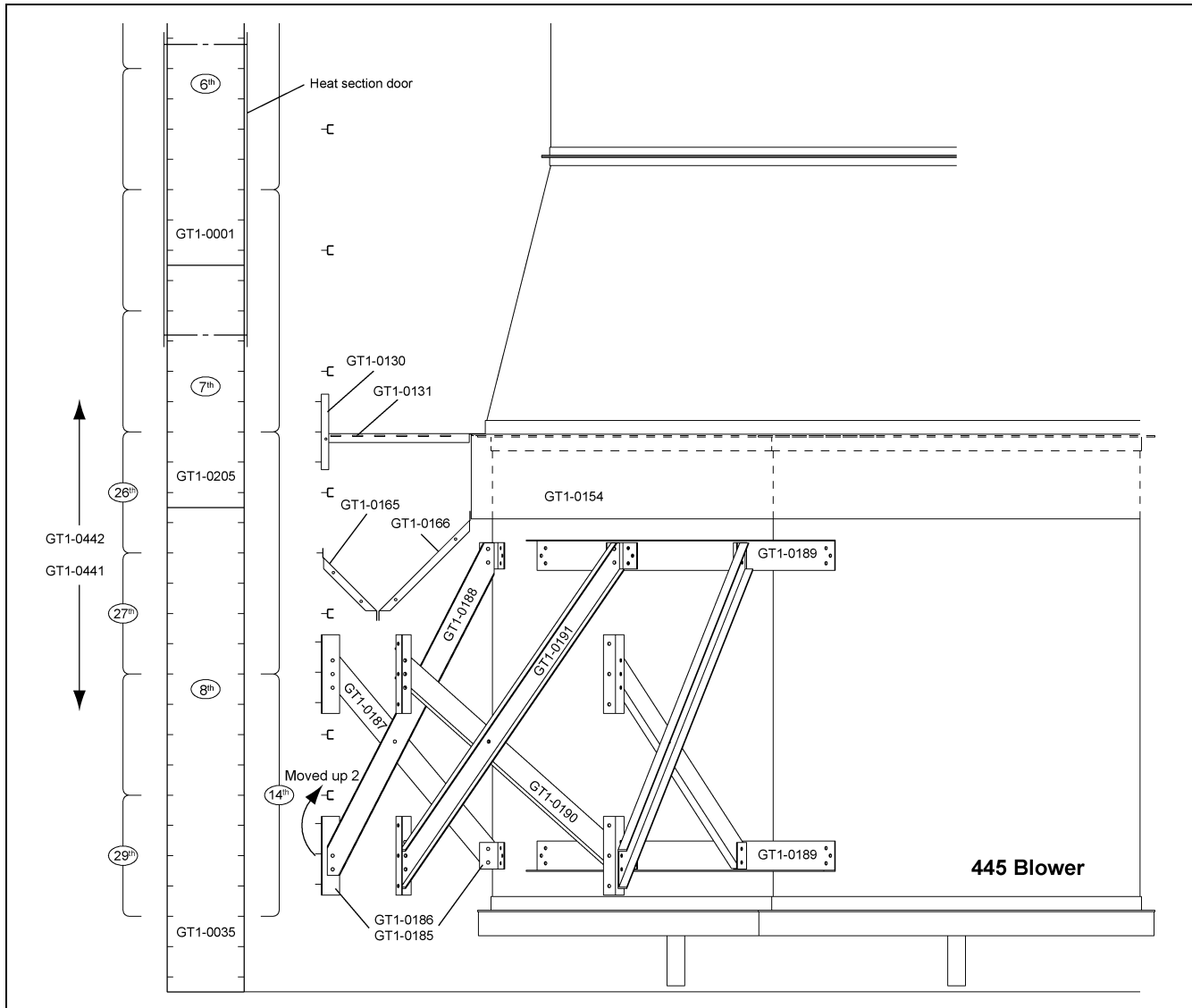

Figure 15D

Part #	Description	Qty
GT1-0130	Reducer Walkway Support Clip	12
GT1-0131	Reducer Walkway Support Beam 445	12
GT1-0154	Blower Skirting 445	4
GT1-0165	Outer Divider Hopper	12
GT1-0166	Inner Divider Hopper 445	12
GT1-0185	Blower Support Clip	24
GT1-0186	Blower Crossbeam Clip	24
GT1-0187	Blower Crossbeam Short Main 445	6
GT1-0188	Blower Crossbeam Long Main 445	6
GT1-0189	Intermediate Blower Support Beam 445	6
GT1-0190	Blower Crossbeam Short Intermediate 445	6
GT1-0191	Blower Crossbeam Long Intermediate 445	6

15. Fans, Divider Hopper, Reducer Walkway

Fan X-Bracing, Divider Hopper, and Reducer Walkway Model 3500

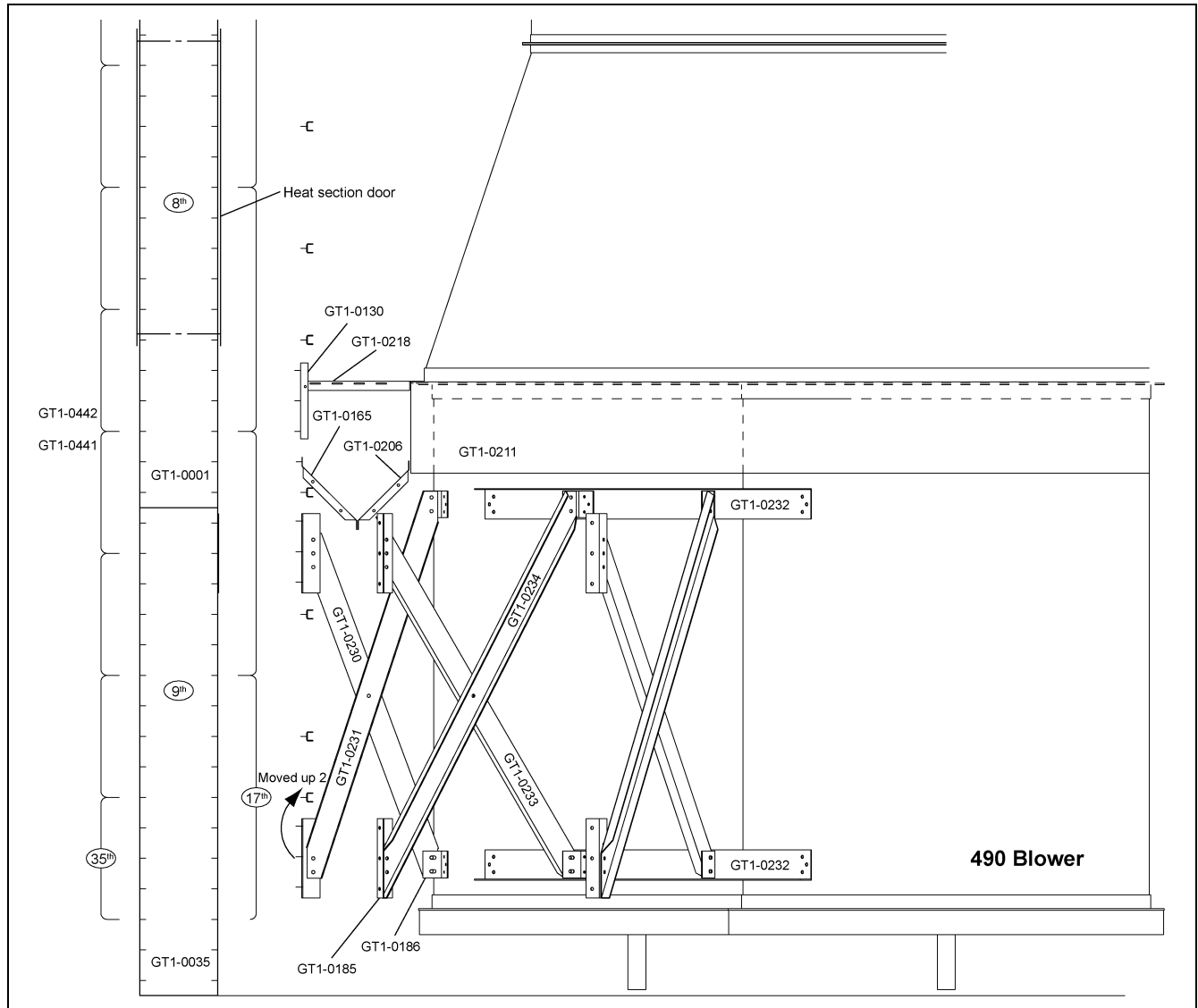

Figure 15E

Part #	Description	Qty
GT1-0130	Reducer Walkway Support Clip	12
GT1-0165	Outer Divider Hopper	12
GT1-0185	Blower Support Clip	24
GT1-0186	Blower Crossbeam Clip	24
GT1-0206	Inner Divider Hopper 490	12
GT1-0211	Blower Skirting 490	6
GT1-0218	Reducer Walkway Support Beam 490	12
GT1-0230	Blower Crossbeam Short Main 490	6
GT1-0231	Blower Crossbeam Long Main 490	6
GT1-0232	Blower Intermediate Support Beam 490	6
GT1-0233	Blower Crossbeam Short Intermediate 490	6
GT1-0234	Blower Crossbeam Long Intermediate 490	6

Fan X-Bracing, Divider Hopper, and Reducer Walkway Model 4000

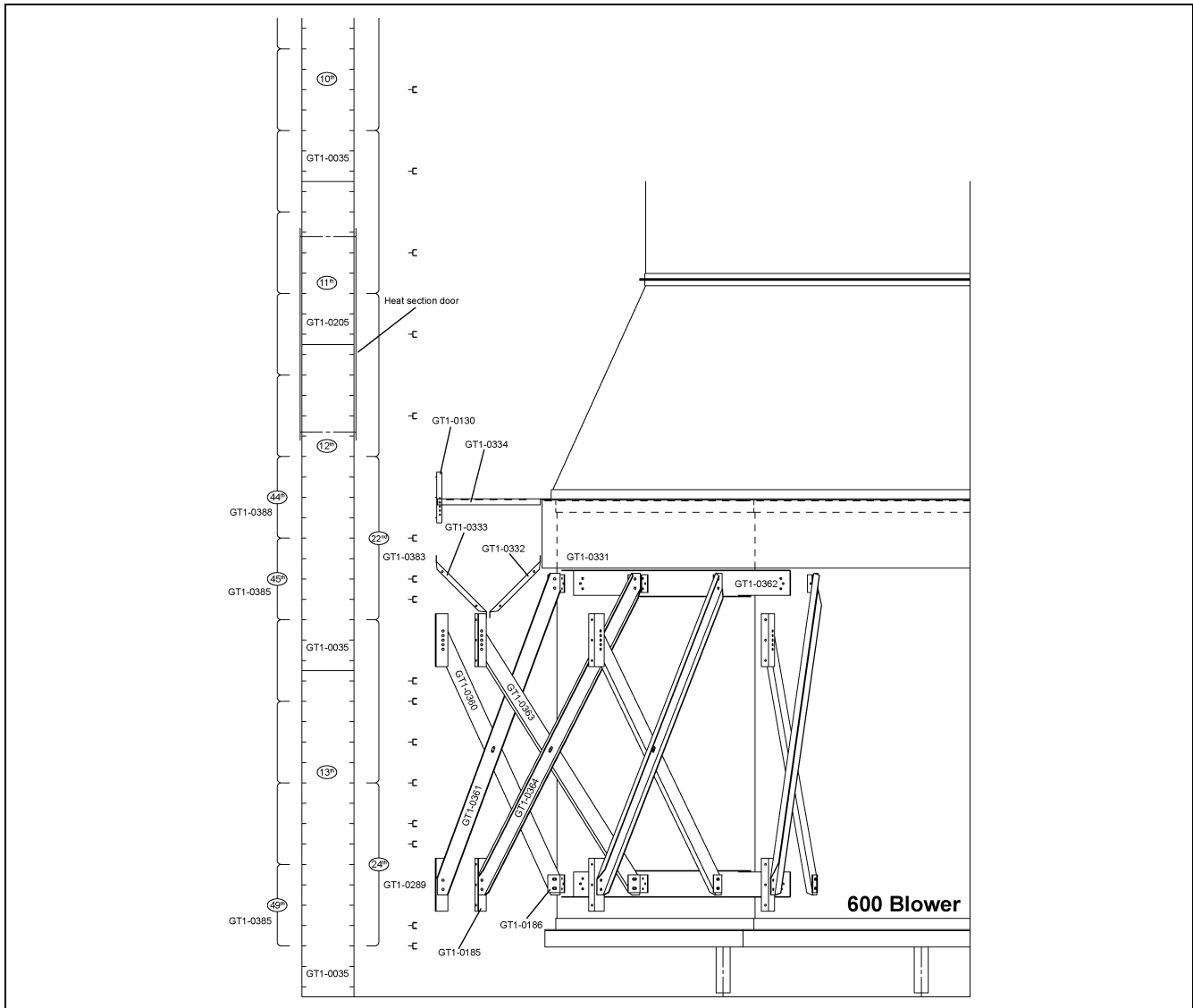

Figure 15F

Part #	Description	Qty
GT1-0130	Reducer Walkway Support Clip	16
GT1-0185	Blower Support Clip	32
GT1-0186	Blower Crossbeam Clip	32
GT1-0331	Blower Striking - 24'	10
GT1-0332	Inner Divider Hopper - 24'	16
GT1-0333	Outer Divider Hopper - 24'	16
GT1-0334	Reducer Walkway Support Beam	16
GT1-0360	Blower Xbeam - Short Main - 24'	8
GT1-0361	Blower Xbeam - Long Main - 24'	8
GT1-0362	Blower Beam - Intermediate - 24'	8
GT1-0363	Blower Xbeam - Short Intermediate - 24'	8
GT1-0234	Blower Xbeam - Long Intermediate - 24'	8

15. Fans, Divider Hopper, Reducer Walkway



Important Safety Precautions:

Dryer has sharp edges. These sharp edges may cause serious injury. Use appropriate personal protective equipment. Use proper lifting techniques.

See [Orientation Section on Page 19](#) for dryer dimensions, components, wall sheet guidelines, etc.
See [Appendix A on Page 435](#) for tools and equipment, [Appendix B on Page 437](#) for hardware, etc.

Fans (3), Divider Hopper, Reducer Walkway

Fan Parts

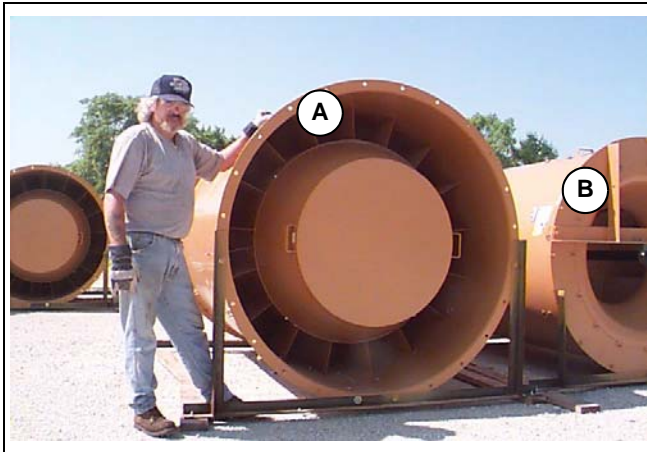

Figure 15G Fan (centrifugal fans). Top view of fan A.

A. 490 Fan (3500 BPH and 4000 BPH dryers).

B. 445 Fan (2500 BPH and 3000 BPH dryers).

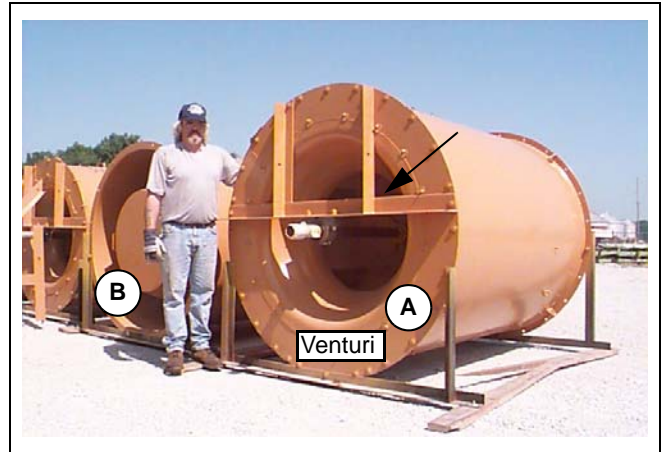

Figure 15H Bottom view of fan A.

Motor Mount Angles - pre-installed at factory (arrow).

Venturi - is the curved inside wall of fan.



Figure 15I Fan Housing Splice



Figure 15J Fan Reducer Panel

Fan Parts (Continued)

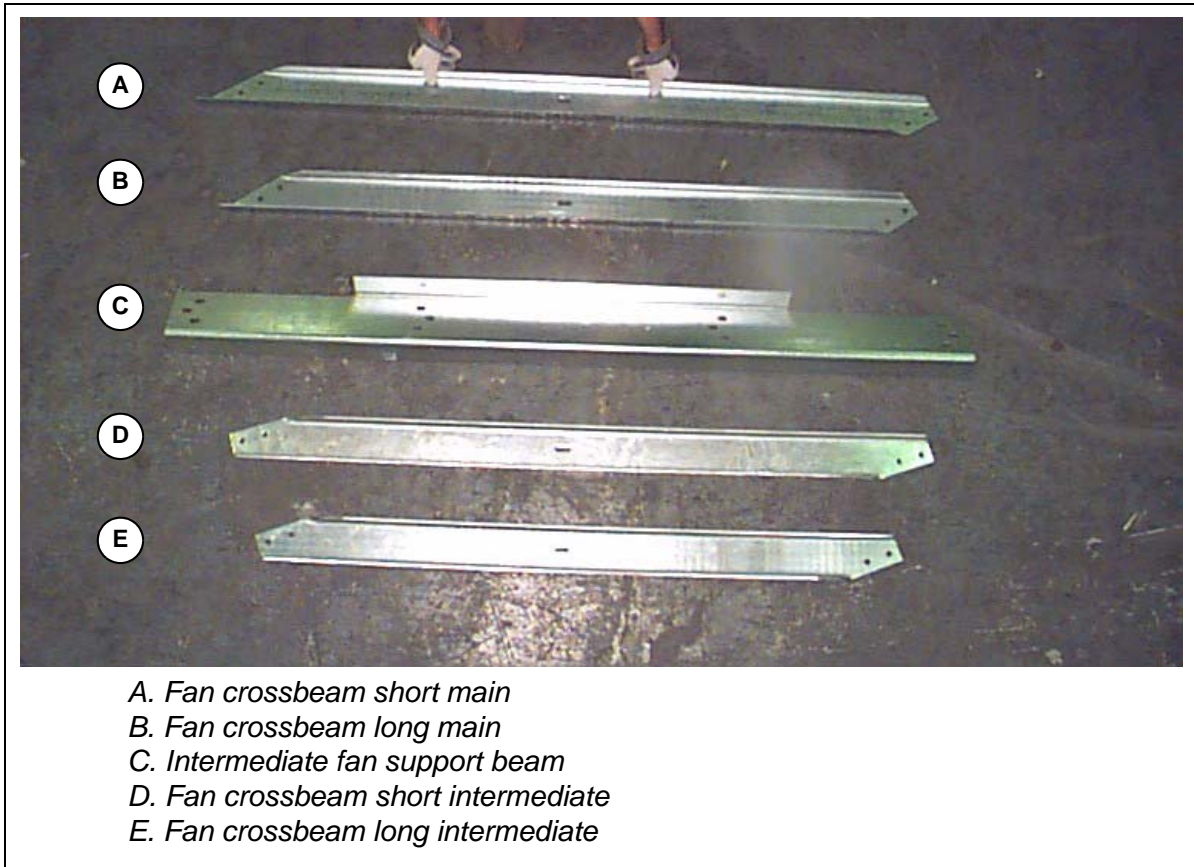

Figure 15K



Figure 15L Fan Crossbeam Clip

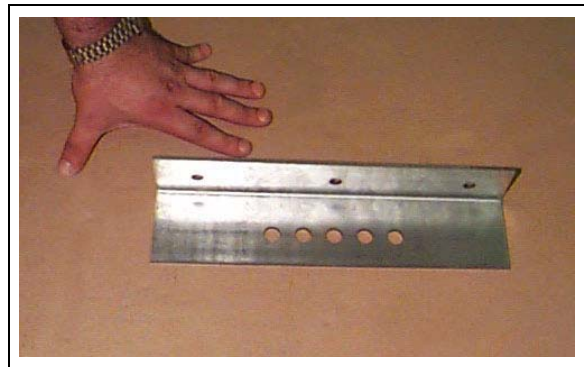

Figure 15M Fan Support Clip

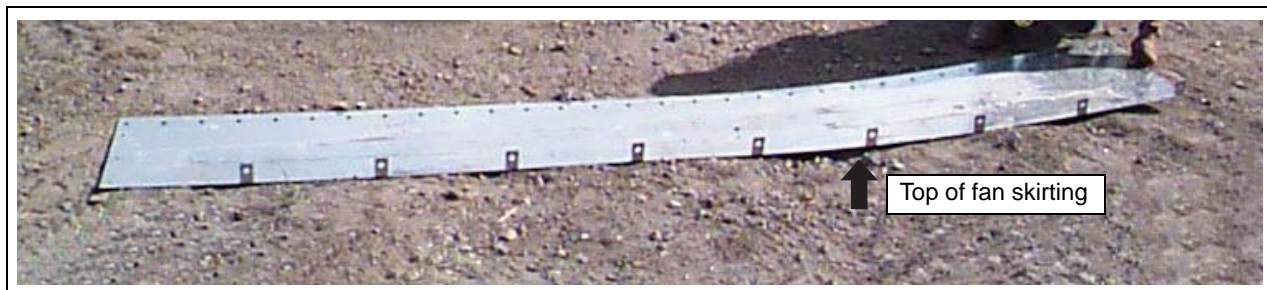

Figure 15N Fan Skirting Section

15. Fans, Divider Hopper, Reducer Walkway

Move Fans into Dryer

Lift reducer/burner to clear fans and move all three (3) fans into dryer on moving dollies as follows.

NOTE: *This is the beginning of cool section construction.*

NOTE: *Inside ladder is not installed in cool section.*

NOTE: *Leave out bolts for fan support clip in vertical channels as shown for the dryer model in [Figure 15C on Page 156](#) to [Figure 15F on Page 159](#) for fan X-bracing.*

1. Remove tape from fan drive shaft.
2. Remove key from fan drive shaft and save for later motor sheave and belt installation.
3. Slide dolly on fan drive shaft. Center it and tighten dolly bolts.
Check keyway is clear of bolts.
4. Attach lifting tackle to fan lift eyelets. Lift fan about 8".
Check lifting tackle connections are secure.
5. Move all three (3) fans next to dryer. Stand fans up vertical with drive shaft down on dolly.
6. Push fans into dryer.
7. When all fans are inside dryer, fill in vertical channel, wall sheets, and rolled plenum channels.
8. Position three (3) fans inside dryer as follows.
 - Fans form a cluster. To determine fan cluster orientation for the model, [see Orientation Section Illustration on Page 32](#) for flat layout for the model.

Turn each fan so that when motor mount is installed (in later step), each fan motor will be centered on an inside wall sheet where free air windows will be installed. (Air draws over and cools fan motors.)

 - Exactly center fan cluster inside walls of dryer. (This allows installation of divider hopper between fans and inside dryer walls in later step.)
 - Adjust so top and bottom rings of fans are level and touching.
9. Note position of upper grease zerk on each fan for installation of grease tube in later step.



Figure 15O *Motor Dolly - Top*

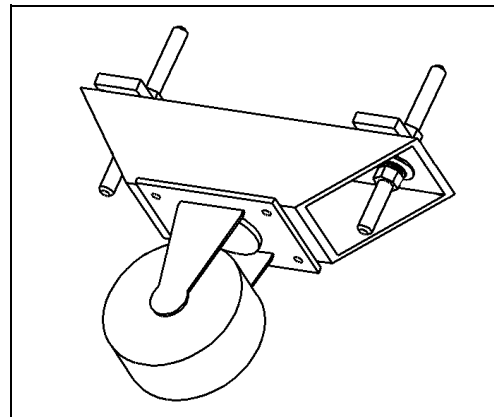

Figure 15P *Blower Dolly - Bottom*

Move Fans into Dryer (Continued)



Figure 15Q *Checking clearance for fan under reducer/burner.*



Figure 15R *Remove fan drive shaft key and save it. (Do not discard.)*



Figure 15S *Lifting tackle is attached to fan lift eyelets.*



Figure 15T *Stand fan up vertical with drive shaft down on dolly.*

Move Fans into Dryer (Continued)



Figure 15U Move fans to dryer.



Figure 15V Pushing fans into dryer.



Figure 15W Three (3) fans form a cluster inside dryer.



Figure 15X Re-installing vertical channel after fans are inside dryer.

Move Fans into Dryer (Continued)

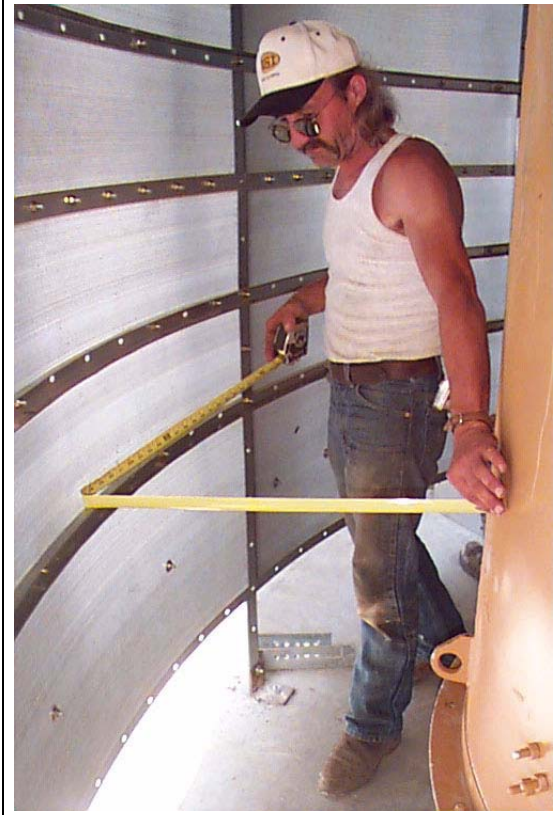

Figure 15Y *Measuring to exactly center fan cluster inside walls of dryer.*

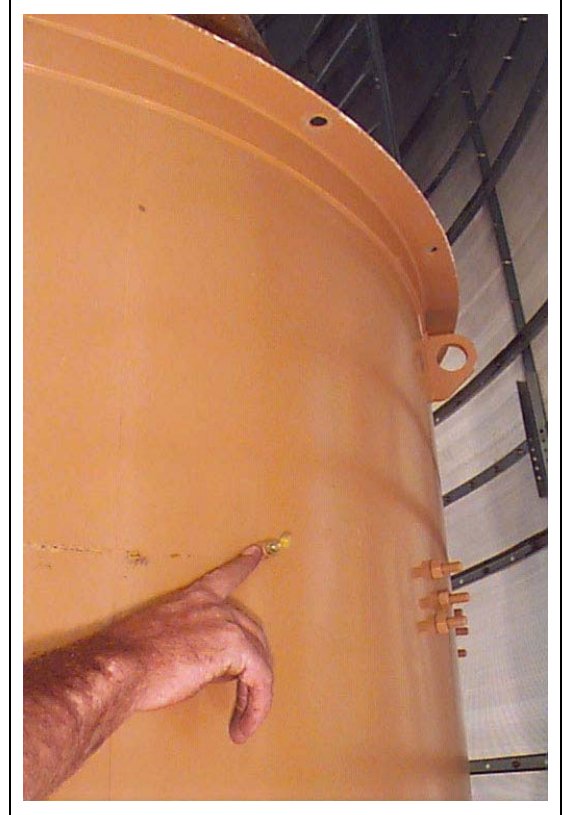

Figure 15AA *Note location of upper grease zerk for installation of grease tube in later step.*

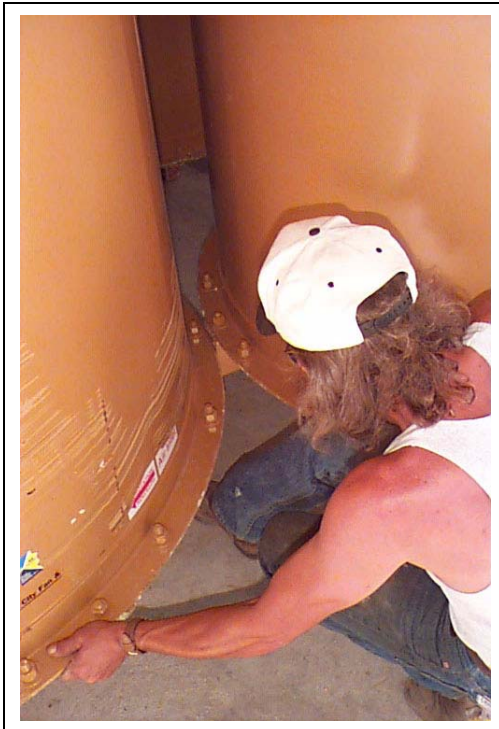

Figure 15Z *Positioning Fans in a cluster with Top and bottom rings level and touching*



Figure 15AB *Close Up - Upper Grease Zerk*

15. Fans, Divider Hopper, Reducer Walkway

Splicing

To close in space around fans, install fan housing splice and six (6) fan reducer panels as follows.

See *Figure 15A on Page 154* for fan splicing.

1. Lower reducer/burner down to top of fans.

Check lower ring of reducer is centered over fan cluster. Align lower ring of reducer with two (2) outer bolt holes in top ring of each fan.

Check fans are level.

Check reducer is exactly centered within inner wall of dryer.

2. Center fan housing splice above fan cluster, and bolt where it overlaps top rings of fans.

Use 1/2" x 1" bolts and nuts with washer.

3. Bolt lower ring of reducer in two (2) outer bolt holes in top ring of each fan. Use 3/8" x 1" bolts and nuts with washer.

4. Bolt fan reducer panels to fill space around fans as follows.

To bolt fan reducer panels to top rings of fans or bottom ring of reducer, use 1/2" x 1" bolts and nuts with washer.

Where fan reducer panels overlap, use 1/2" x 3/4" bolts and nuts with washer.



Figure 15AC Bolting fan housing splice, centered on top of fan cluster.



Figure 15AE Bolting fan reducer panel.



Figure 15AD Positioning fan reducer panel.

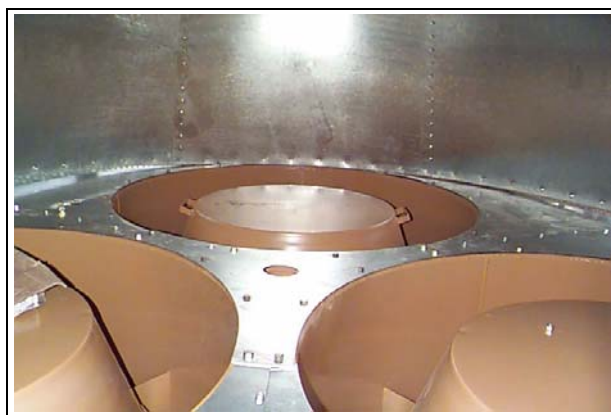

Figure 15AF Fan housing splice installed.

X-Bracing

X-Bracing forms an “X” between clips on fans and clips on vertical channels. For placement of clips and X-bracing, see [Figure 15C on Page 156](#) to [Figure 15F on Page 159](#) for the dryer model.

NOTE: *At this point, reducer walkway support clips can be installed to inside wall sheets with existing bolts. Reducer walkway is installed in later step.*

1. Bolt two (2) fan support clips to each vertical channel. Use 3/8" x 1" bolts and 1/2" nuts.
2. Join each pair of fans with two (2) intermediate fan support beams. Use bolts and nuts that are already on fans, add 1/2" washers.
3. Bolt fan crossbeam clips to fans and to intermediate fan support beams. Use 1/2" x 1" bolts and 1/2" nuts.
4. Bolt fan crossbeams (short main, long main, short intermediate, and long intermediate) to form “X” between fan support clips and fan crossbeam clips. Use 1/2" x 1" bolts and 1/2" nuts with washers.



Figure 15AG Use existing bolts on fans to install intermediate fan support beams and some fan cross beam clips.



Figure 15AI Installing bottom intermediate fan support beam across two (2) fans.



Figure 15AH Installing top intermediate fan support beam across two (2) fans.



Figure 15AJ Installing fan cross beam clip to fan.

X-Bracing (Continued)



Figure 15AK Clips installed.

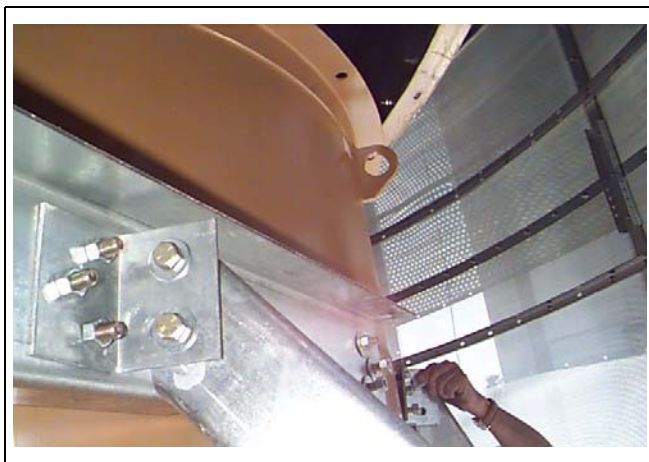

Figure 15AL Top of fan - Installing fan crossbeam to fan crossbeam clip.



Figure 15AM L.H. View of bracing installed to fan support clip.



Figure 15AN R.H. View of bracing installed to fan support clip.



Figure 15AO Bottom of fan - Installing fan crossbeam to fan crossbeam clip.

X-Bracing (Continued)



Figure 15AP X-Bracing installed.



Figure 15AR



Figure 15AQ

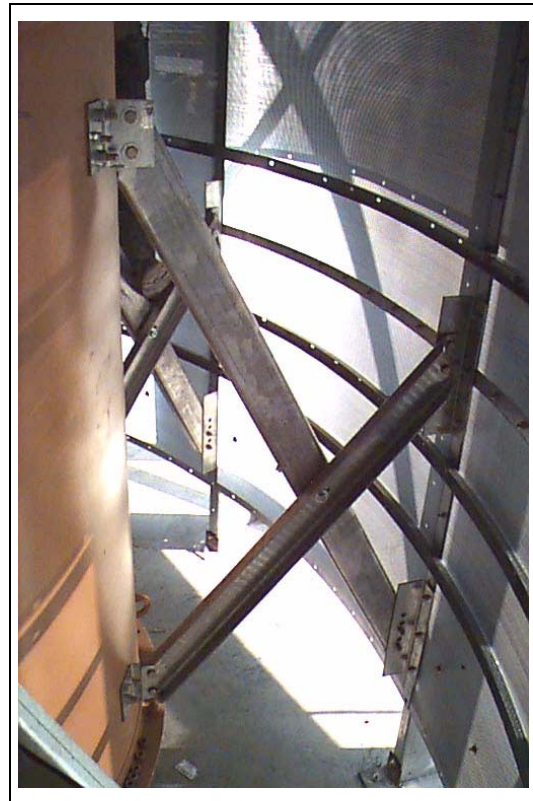

Figure 15AS

15. Fans, Divider Hopper, Reducer Walkway

Fan Skirting

To install fan skirting sections around top of fans, snug bolt widely spaced tabs on top of fan skirting sections to bottom ring of reducer. Snug bolt fan skirting sections together. (See Figure 15AU.)

NOTE: Leave fan skirting loose until after installing reducer walkway support beams.

Use 5/16" x 1" bolts and 1/2" galvanized nuts with washers.



Figure 15AT Aligning fan skirting section to bottom ring of reducer.

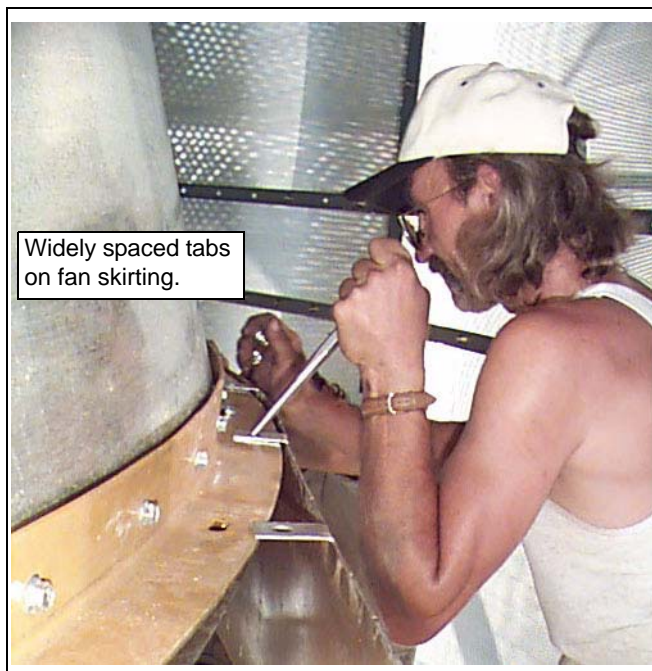

Figure 15AU Bolting widely spaced tabs at top of fan skirting to bottom ring of reducer.

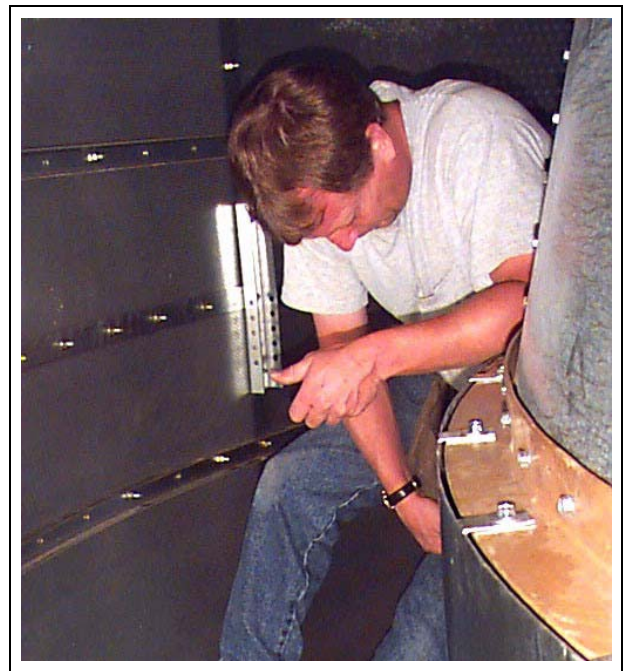

Figure 15AV

Divider Hopper

Divider hopper is formed by joining inner divider hopper sections and outer divider hopper sections in a “V” shape.

Divider hopper encircles fan cluster.

Divider hopper divides heat section from cool section.

Divider hopper fits between fan skirting and inner wall of dryer.

For divider hopper placement in the dryer model, see [Figure 15C on Page 156](#) to [Figure 15F on Page 159](#).

Keep “V” of divider hopper level.

1. Snug bolt top tabs (closely spaced) on inner divider hopper sections to bottom of blower skirting. *(See Figure 15AW.)*
 Snug bolt inner divider hopper sections together.
 Use 5/16" x 3/4" galvanized bolts and nuts.

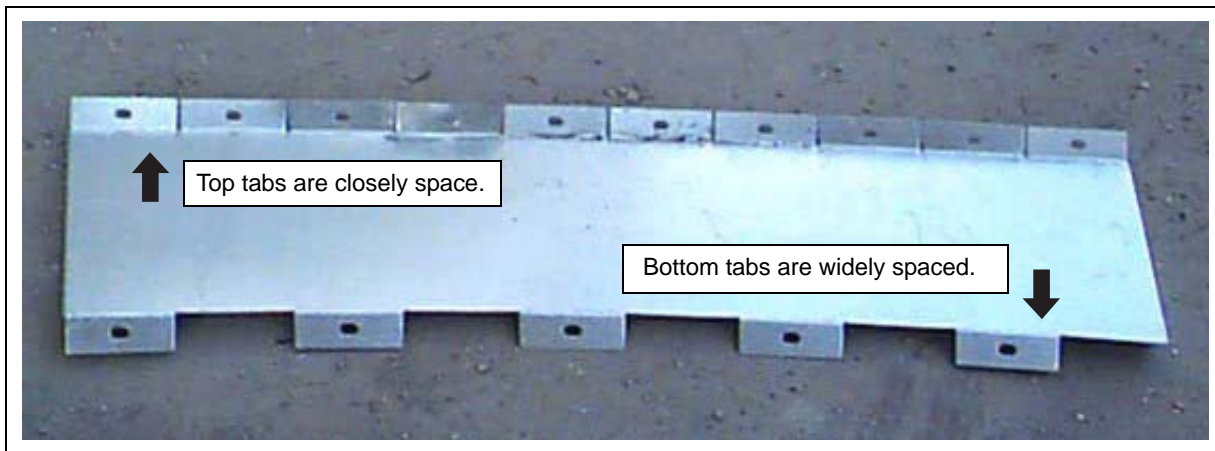

Figure 15AW Inner Divider Hopper Section

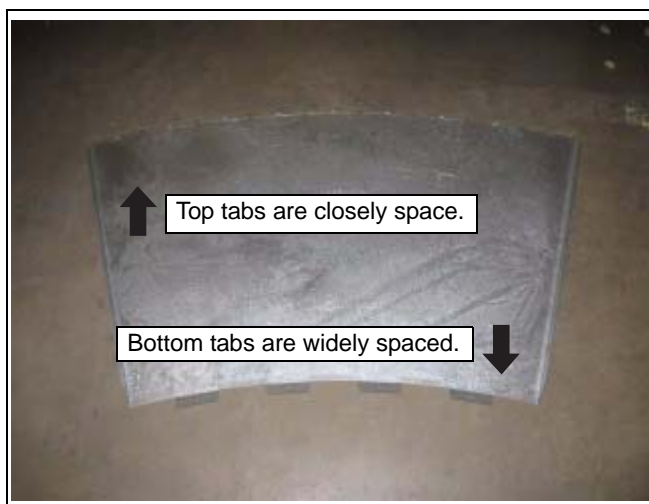

Figure 15AX Outer Divider Hopper Section



Figure 15AY Bolting top tabs of inner divider hopper to bottom of fan skirting.

15. Fans, Divider Hopper, Reducer Walkway

Divider Hopper (Continued)

2. Align and snug bolt bottom tabs (widely spaced) on outer divider hopper sections to bottom tabs on inner divider hopper sections.

Use 5/16" x 1-1/4" galvanized bolts and nuts. Space tabs with 3/8" nut in between.

(See Figure 15BB.)

Snug bolt outer divider hopper sections together.

Use 5/16" x 3/4" galvanized bolts and nuts.

3. Drill inside wall sheets to meet bolt holes in top tabs of outer divider hopper. Snug bolt.

Use 5/16" x 3/4" galvanized bolts and nuts.

NOTE: Leave divider hopper bolts loose, until after reducer walkway is installed.

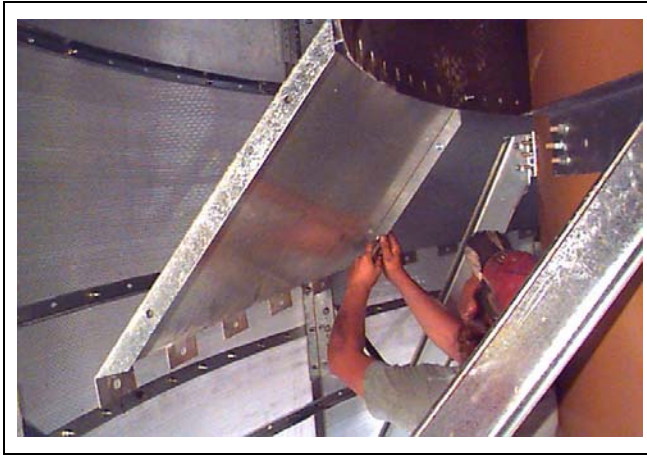

Figure 15AZ Bolting inner divider hopper sections together.



Figure 15BA Bolting outer divider hopper to inner divider hopper.

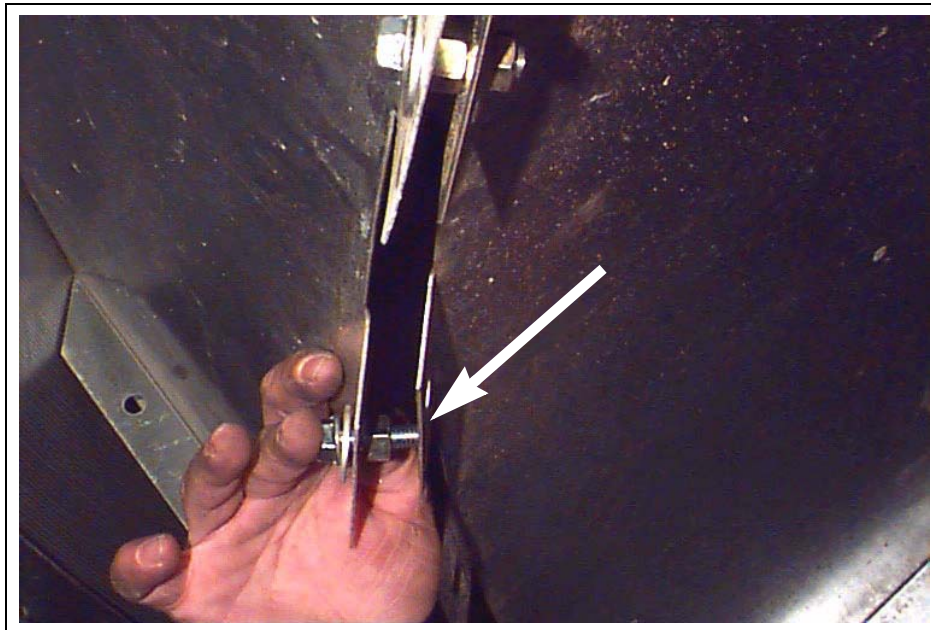

Figure 15BB Close Up - using 3/8" nut (arrow) to space outer divider hopper 1/4" from inner divider hopper.

NOTE: Space between tabs will be 1/4" when outside nut is installed. (Critical gap for debris evacuation.)

Divider Hopper (Continued)



Figure 15BC *Drilling bolt holes in inside wall sheets to bolt to outer divider hopper.*



Figure 15BD *Close Up - bolting outer divider hopper to inside wall sheet.*

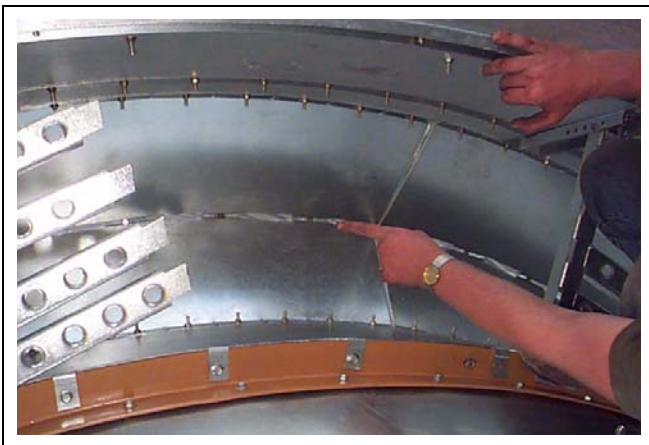

Figure 15BE *View from above divider hopper (in heat section) - Completed divider hopper.*



Figure 15BF *View from above divider hopper*
NOTE: *Wait to tighten divider hopper and fan skirting until after installing reducer walkway support beam (arrow).*

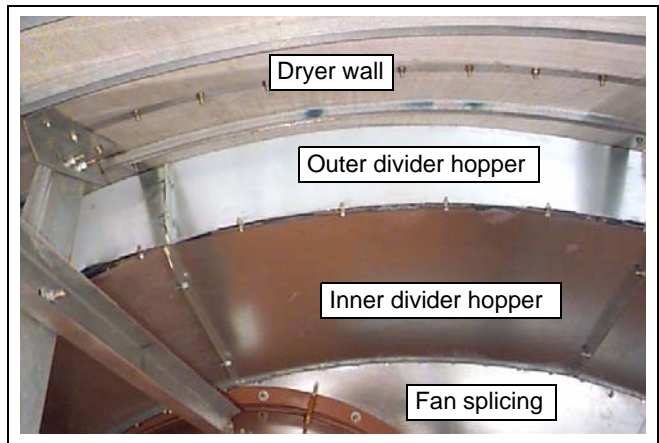

Figure 15BG *View from below divider hopper (in cool section) - Completed divider hopper.*

15. Fans, Divider Hopper, Reducer Walkway

Reducer Walkway

For reducer walkway placement in the dryer model, see [Figure 15C on Page 156](#) to [Figure 15F on Page 159](#).

Reducer walkway encircles fans.

Keep reducer walkway level.

1. Bolt reducer walkway support clips to inside wall sheets with existing bolts (unless reducer walkway support clips were installed when fan X-bracing was installed.) ([See Figure 15AK on Page 168.](#))
2. Install all reducer walkway support beams as follows.
 - Snug bolt tab end of reducer walkway support beam over bottom ring of reducer.
 - Use common bolt (5/16" x 3/4") used to bolt fan skirting.
 - Snug bolt opposite end of reducer walkway support beam to reducer walkway support clip.
 - Check with level to determine which bolt hole on reducer walkway support clips will keep reducer walkway level.
 - Use 5/16" x 3/4" bolts and nuts.
3. Adjust and tighten bolts on divider hopper and reducer walkway support beams.
4. Insert tabs on reducer walkway slats into slots on reducer walkway support beams until slats form reducer walkway that completely encircles blowers.
 - Install shortest slats next to fan skirting. Install increasing longer slats as required.
5. Adjust and tighten bolts on reducer walkway and fan skirting.

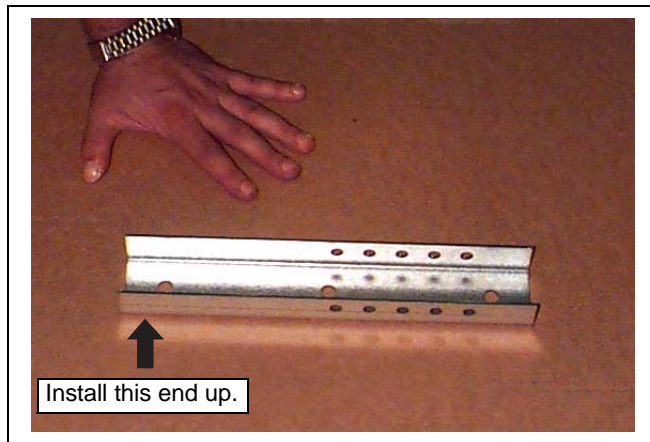

Figure 15BH Reducer Walkway Support Clip

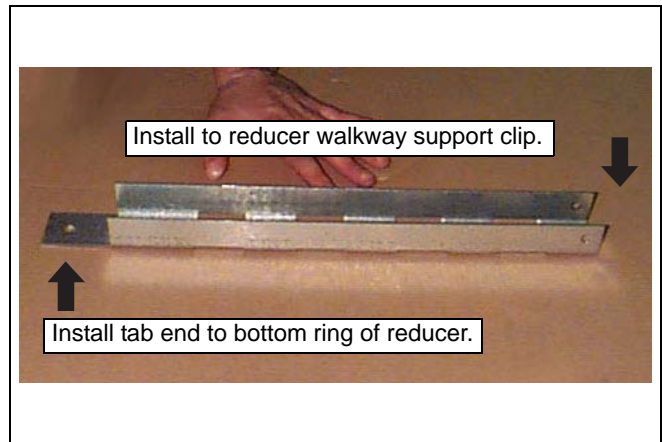

Figure 15BI Reducer Walkway Support Beam



Figure 15BJ Example - Reducer Walkway Slat

Reducer Walkway (Continued)

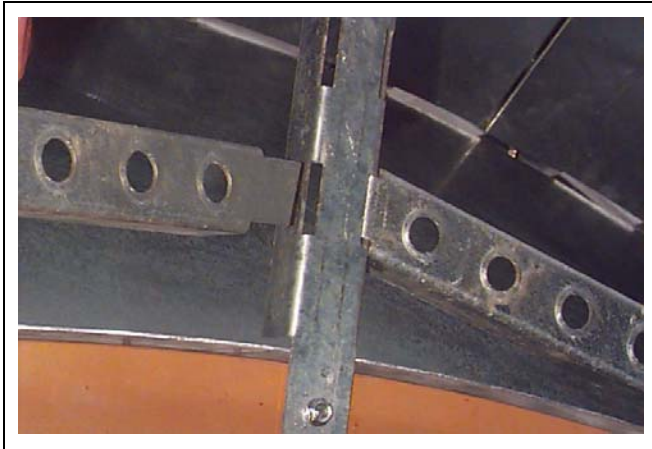

Figure 15BK Close Up - Inserting tab of reducer walkway slat into slot on reducer walkway support beam.

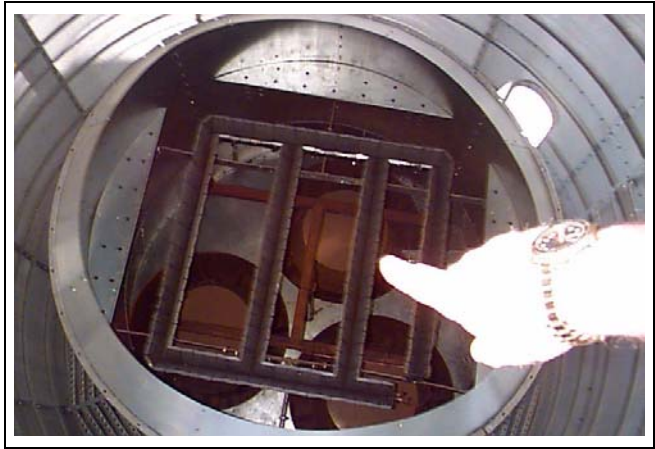
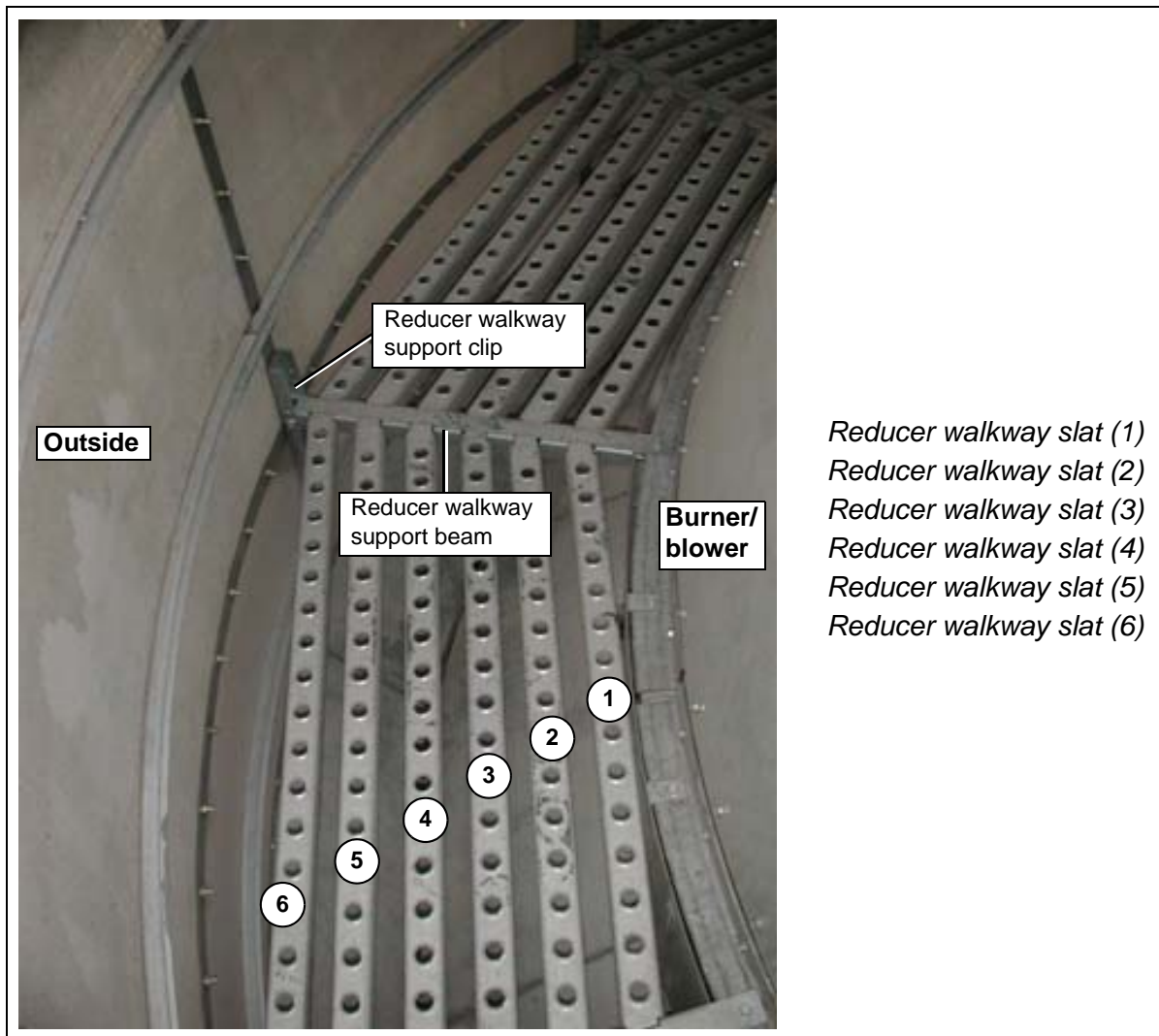

Figure 15BL Aerial view - Completed installation of burner, reducer, fans and divider hopper under reducer walkway.



- Reducer walkway slat (1)
- Reducer walkway slat (2)
- Reducer walkway slat (3)
- Reducer walkway slat (4)
- Reducer walkway slat (5)
- Reducer walkway slat (6)

Figure 15BM



Important Safety Precautions:

Dryer has sharp edges. These sharp edges may cause serious injury. Use appropriate personal protective equipment. Use proper lifting techniques.

See [Orientation Section on Page 19](#) for orientation for dryer dimensions, components, wall sheet guidelines, etc. See [Appendix A on Page 435](#) for tools and equipment, [Appendix B on Page 437](#) for hardware, etc.

NOTE: Install fan motors before installing dryer windows.

Fan Motor Mounts, Fan Motors, Sheaves and Fan Belts

Fan Motor Mounts

1. Install fan motor mounts to each fan as follows.
Use hardware in standard hardware kit. (See [Figure 16B](#).)
2. If necessary, lift dryer for clearance to install fan motor mounts.
3. Install fan motor mount to bottom of fan.



Figure 16A Fan Motor Mount (arrow)

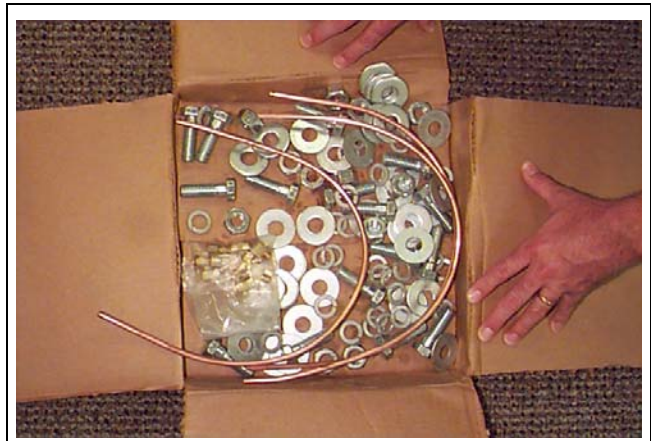

Figure 16B Standard Hardware Kit (1 per fan)

Fan Motor Mounts (Continued)



Figure 16C Moving fan motor mount under fan.



Figure 16D Align fan motor mount and bolt to fan.



Figure 16E Bolting motor mount to bottom ring of fan.



Figure 16F Tightening bolts on fan motor mount.



Figure 16G Fan motor mount installed.

IMPORTANT: Take all appropriate safety action while working under blowers/fans.

16. Fan Motors

Fan Motors

Install fan motor to each fan motor mount as follows.

Lift or lower dryer as necessary to install fan motors.

1. Attach lifting tackle to fan motor. (See Figure 16H.) Lift fan motor onto fan motor mount, with drive shaft up.
2. Bolt fan motor to fan motor mount in bolt holes appropriate to motor size.
May be necessary to lift dryer to insert bolts.
Use 5/8" x 2" bolts, nuts and washers from standard hardware kit.



Figure 16H Attach lifting tackle to fan motor.



Figure 16J Bolting fan motor to fan motor mount.



Figure 16I Moving fan motor to fan motor mount.



Figure 16K Fan motors installed to fan motor mounts.

Sheaves

Install sheaves to each fan motor mount as follows.

1. Lift dryer for clearance.
2. Motor drive shaft.
Install motor hub to motor drive shaft. Insert motor hub key. Set set screw. Slide motor sheave on motor drive shaft and bolt.
3. Fan drive shaft.
Install fan hub to fan drive shaft. Insert fan hub key. Tighten set screw. Slide fan sheave on fan drive shaft and bolt.
4. Align top of motor sheave level with top of fan sheave.
Check with level.

NOTE: Final tightening of bolts should be with torque wrench.

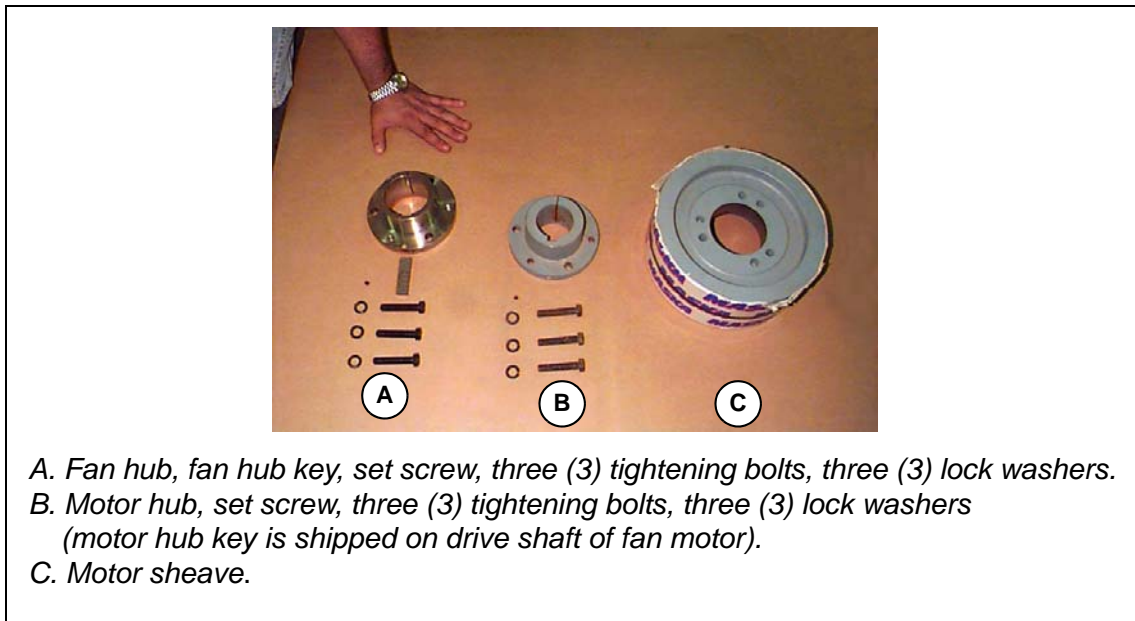

Figure 16L



Figure 16M Fan Sheave



Figure 16N Sliding motor hub on motor drive shaft.

Sheaves (Continued)



Figure 16O *Tightening set screw on motor hub.*



Figure 16R *Sliding fan hub on fan drive shaft.*



Figure 16P *Sliding motor sheave on motor drive shaft.*



Figure 16S *Placing fan hub key in fan hub.*



Figure 16Q *Inserting motor sheave to motor hub.*



Figure 16T *Tightening set screw on fan hub.*

Sheaves (Continued)



Figure 16U Sliding fan sheave on fan drive shaft.



Figure 16W Tightening fan sheave bolts.



Figure 16V Checking top of motor sheave is level with top of fan sheave.



Figure 16X Tightening motor sheave bolts.
NOTE: Final tightening of bolts should be with torque wrench.

Fan Belts



When installing fan belts, do not catch fingers in fan belts.

1. For each fan, run fan belts from motor sheave to fan sheave.
2. To tighten fan belts, tighten adjusting nuts on two (2) rods on motor mount. Do not overtighten fan belts.

Check fan belt tension. Fan belts will press down one fan belt width.

(See Figure 16AC on Page 183.)



Figure 16Y Fan belts

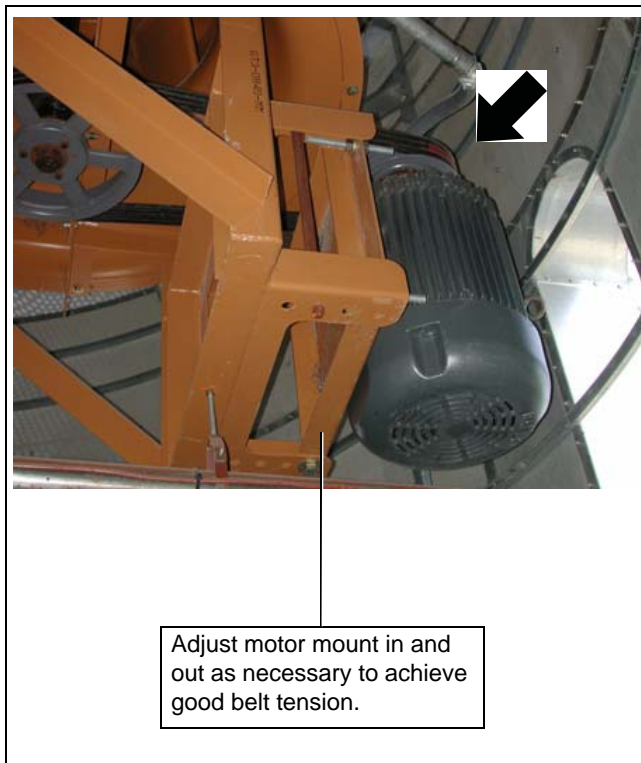

Figure 16Z Running fan belts in grooves on sheaves.

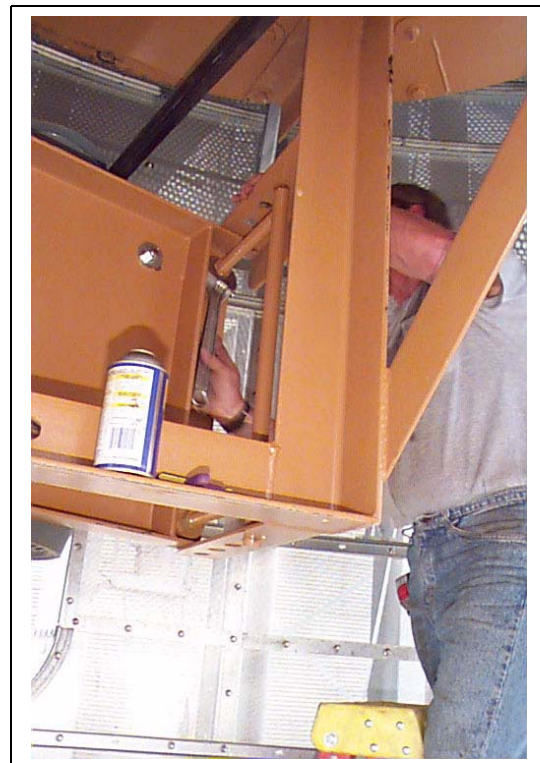

Figure 16AA (To tighten fan belts) tightening adjusting nuts on top rod of motor mount.



Figure 16AB *Checking fan belt tension. Can press down about one fan belt width.*



Figure 16AC *Once belts have proper tension, tightening adjusting nuts on bottom rod of motor mount.*

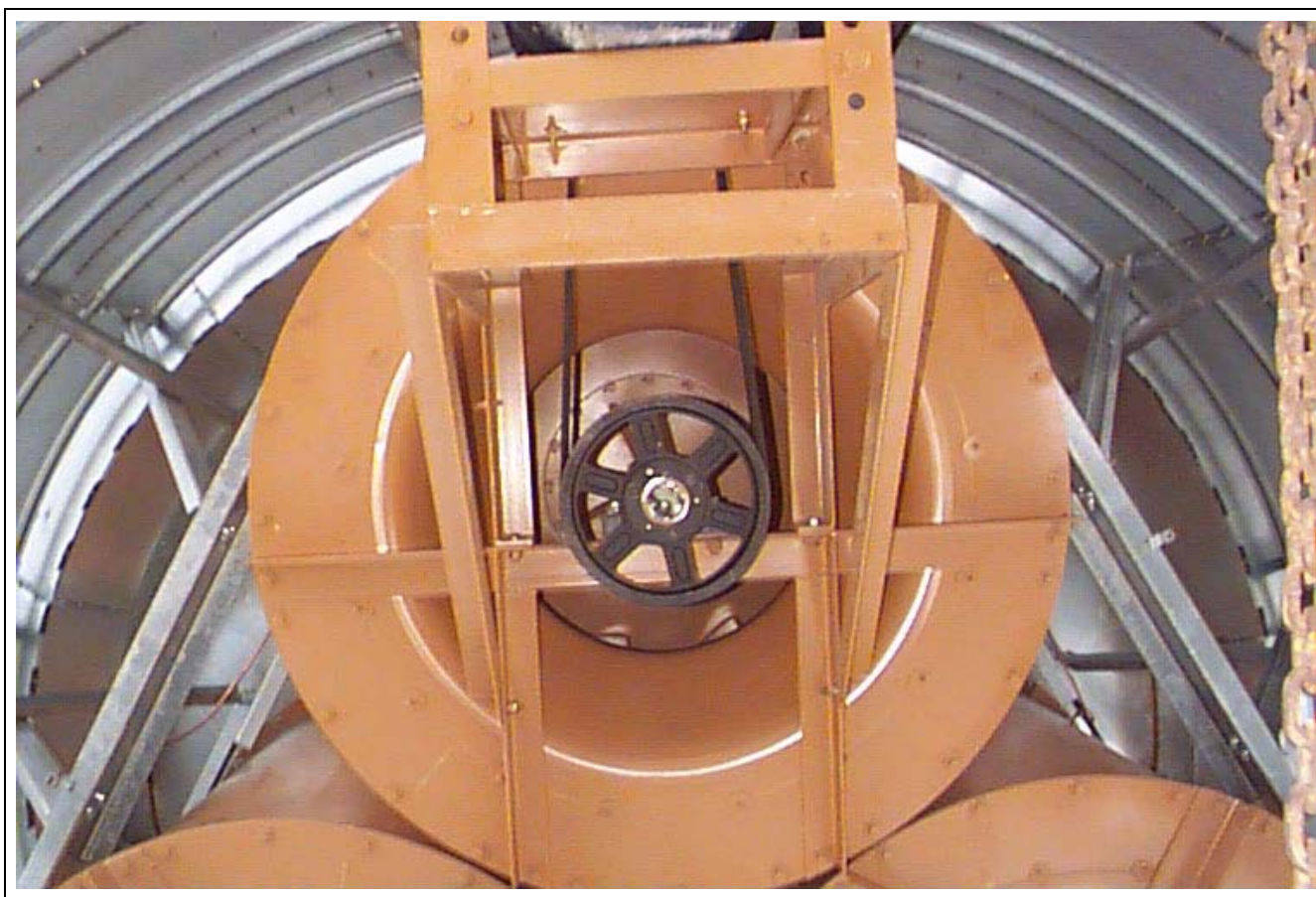

Figure 16AD *Fan sheave and belts installed.*

17. Grease Tubes



Important Safety Precautions:

Dryer has sharp edges. These sharp edges may cause serious injury. Use appropriate personal protective equipment. Use proper lifting techniques.

See [Orientation Section on Page 19](#) for dryer dimensions, components, wall sheet guidelines, etc. See [Appendix A on Page 435](#) for tools and equipment, [Appendix B on Page 437](#) for hardware, etc.

NOTE: Upper bearing on fan requires grease tube for access.

NOTE: Lower bearing on fan requires no grease tube.

All required fittings are shipped attached to grease tube.

1. Unscrew grease zerk from fan.
2. Install grease zerk to coupling on beam clamp end of grease tube.
3. Install elbow end of grease tube to fan.
4. Clamp beam clamp to bottom edge of fan, or where convenient.



Figure 17A Close Up - Grease zerk on fan.



Figure 17C Close Up - Elbow end of grease tube (A).

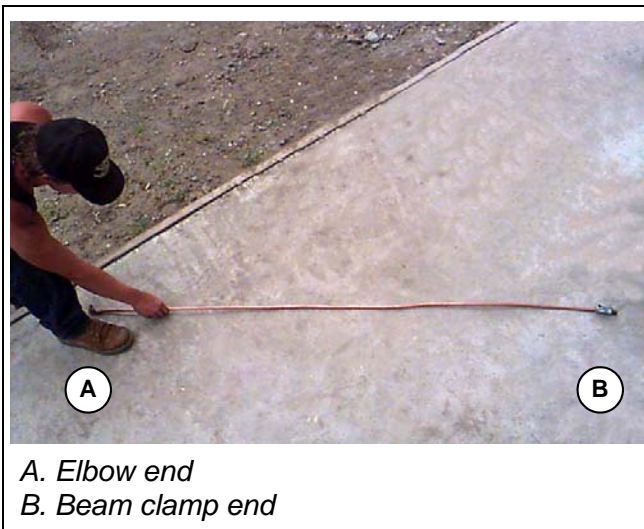

A. Elbow end
B. Beam clamp end

Figure 17B Grease tube for upper bearing on fan.

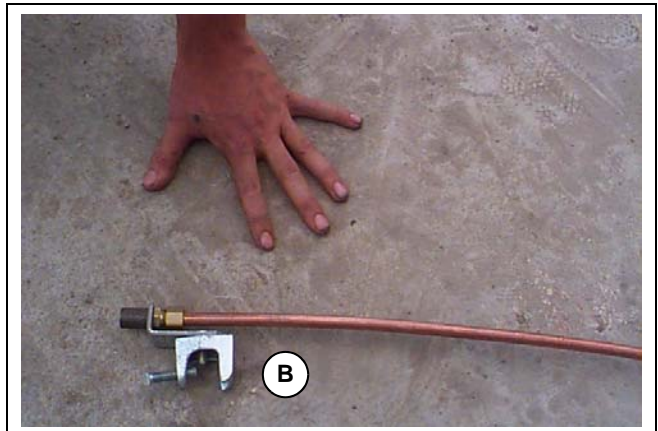

Figure 17D Close Up - Beam clamp end of grease tube (B).



Figure 17E Accessing upper grease zerk.

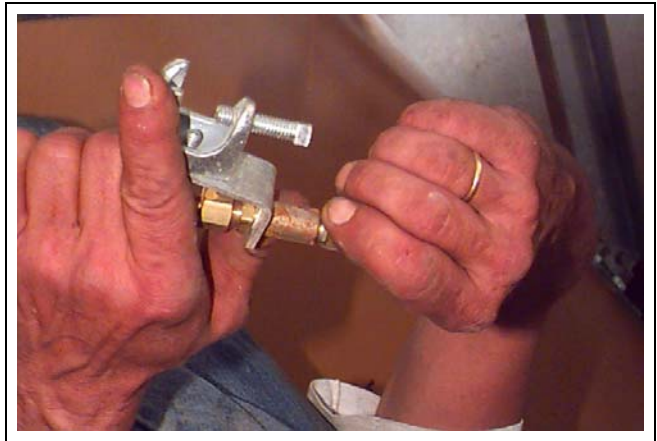

Figure 17H Screwing grease zerk into coupling on beam clamp end of grease tube.



Figure 17F Grease zerk on fan (circled).



Figure 17G Grease zerk removed from fan.



Figure 17I Elbow and brass compression union installed to fan (circled).



Figure 17J *Attaching grease tube to brass compression union.*

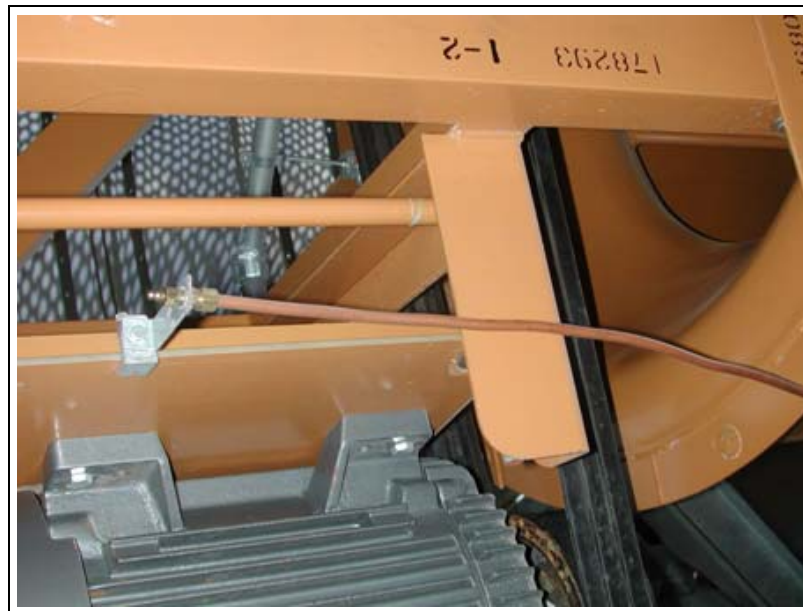

Figure 17K *Attaching beam clamp to bottom edge of fan/motor mount/or easily accessible for service. (While clearance from moving parts.)*



Important Safety Precautions:
 Dryer has sharp edges. These sharp edges may cause serious injury. Use appropriate personal protective equipment. Use proper lifting techniques.

[Orientation Section on Page 19](#) for dryer dimensions, components, wall sheet guidelines, etc.
[See Appendix A on Page 435](#) for tools and equipment, [Appendix B on Page 437](#) for hardware, etc.

NOTE: [See Orientation Section on Page 32](#) for flat layout for window and door placement in the dryer model.

NOTE: Windows are installed in cool section wall sheets. [See Orientation Section on Page 32](#) for flat layout for type of wall sheet to use.

NOTE: Window installation requires cutting wall sheets on-site.

Check that wall sheets are lapped correctly, with rough side away from grain column.

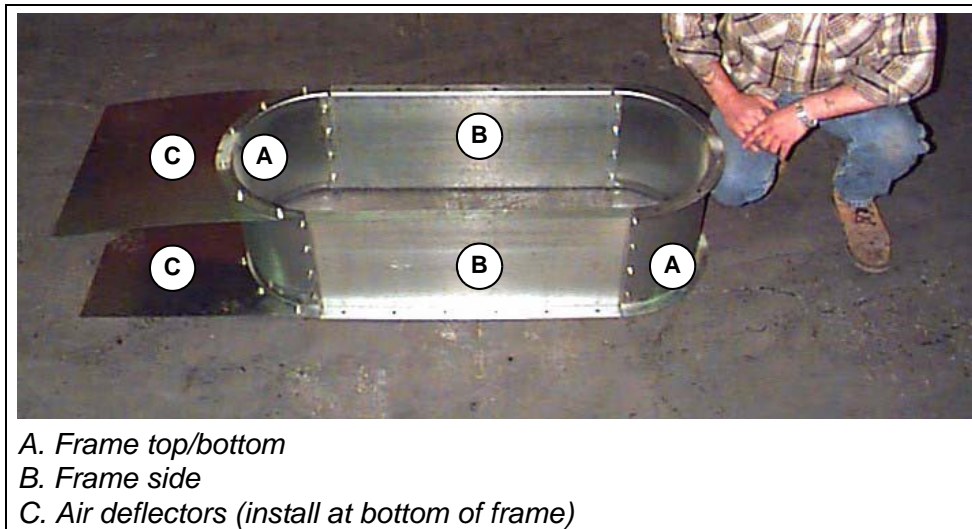

Figure 18A 18" Window Kit (Assembled for demonstration.) (May come from factory partially assembled.)

NOTE: 24" Window kit is not shown. It has same parts (on larger scale) as 18" window kit.

Overview

1. Pre-assembly of window kits.

Pre-assemble 18" window kit and 24" window kit in the same way.

2. Installation of window kits.

Install 18" window kit and 24" window kit to dryer in the same way.

3. Screened windows.

Position at same level as fan motors. Use 18" window kit and screening.

4. Louvered windows.

Position at same level as cool section door. Use 24" window kit and louvered assembly.

5. Cool section door.

Use 24" window kit, louvered assembly, and door parts.

6. Heat section door.

Use 18" window kit, and door parts.

7. Reducer door.

8. Hopper service door.

18. Windows and Doors

Hardware

Assembling window frame	Use 5/16" x 3/4" slotted truss head bolts and 5/16" whiz lock nuts.
Installing window frame to dryer wall sheets.	Drill for 5/16" x 1" whiz lock bolts and nuts. (Stainless steel on outside, and galvanized on inside.)
Window screening	Double nut window screening to windows with existing bolts on outside wall sheets.
Louvered assembly	5/16" x 3/4" whiz lock bolts and nuts.



Figure 18B Louvered Assembly



Figure 18C 5/16" x 3/4" Slotted truss head bolt and 5/16" whiz lock nut.



Figure 18D Use metal shear to cut wall sheets and screen.



Figure 18E Bulb Seal

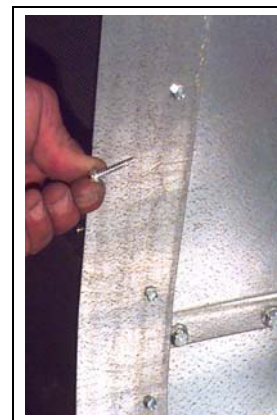

Figure 18F Self-tapping #10 x 1" Screw

Pre-assembly of Window Kits

Pre-assemble 18" and 24" window kits in the same way.



Figure 18G On a raised support, layout inside wall sheets that will support assembled window. Lap wall sheets as they should be lapped on dryer.

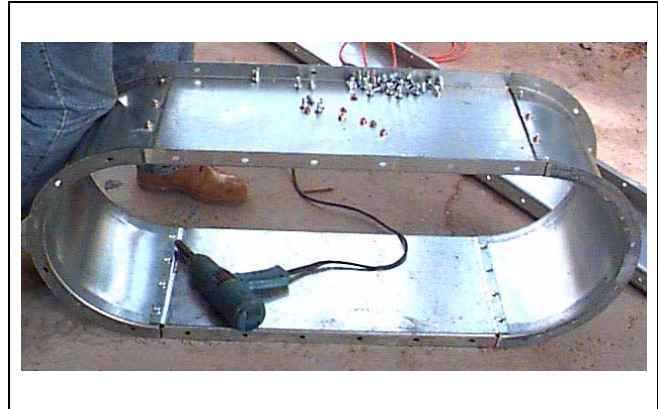

Figure 18J Assemble window frame, using 5/16" x 3/4" slotted truss head bolts and 5/16" whiz lock nuts.



Figure 18H Align bolt holes in the two (2) wall sheets.

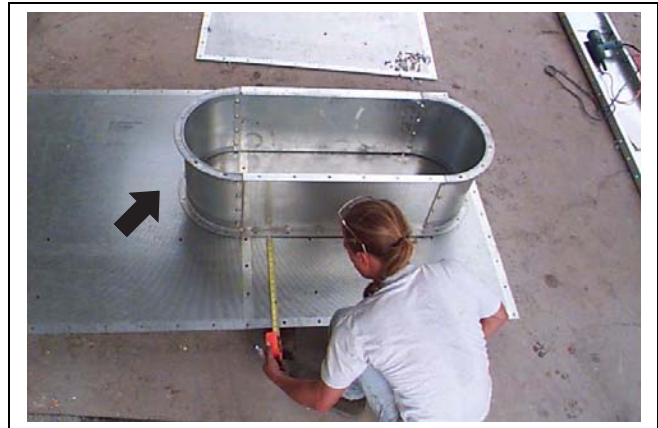

Figure 18K See [Orientation Section on Page 19](#) for assembly layout for placement of window frame on wall sheets. Leave room below window frame (arrow) for air deflector.



Figure 18I Temporarily snug bolt corners of two (2) wall sheets.



Figure 18L Mark around inside perimeter of window frame.

Pre-assembly of Window Kits (Continued)



Figure 18M Close Up - Mark window frame bolt holes.



Figure 18P Close Up - Aligning wall sheets to window frame so bolt holes can be drilled. Note wall sheets are installed on top of window frame flange.

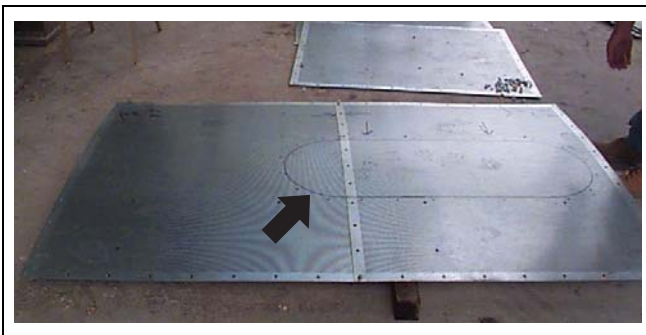

Figure 18N Line marked (by arrow) is inside perimeter of window frame. Cut on outside of line because wall sheets will lie inside window frames.

NOTE: Can save wall sheet cut out to use as a pattern on next dryer installed.

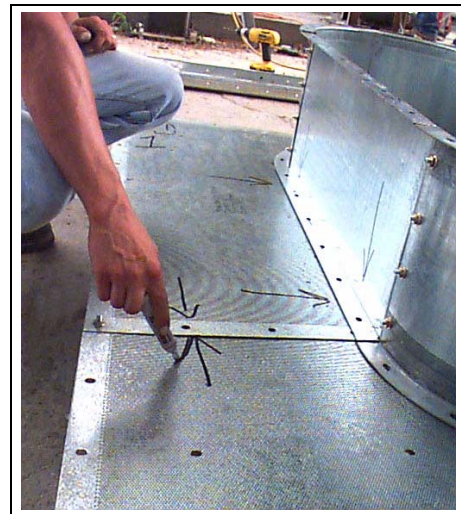

Figure 18Q Match marks on each sheet. Draw arrow to indicate "up" direction for installation.



Figure 18O After cutting window outline, realign window frame to wall sheets and drill out bolt holes.

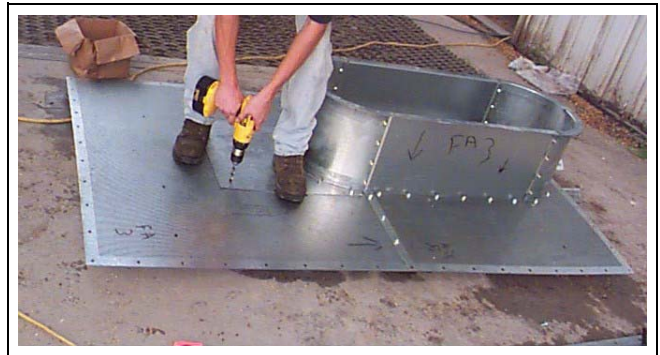

Figure 18R Bolt window frame to wall sheets.

Drill bolt holes for air deflector at bottom of window frame, drilling 1" x 1" from corners.

Installation of Window Kits (18" and 24")

Install 18" and 24" window kits in the same way.

Read section [Screened Windows on Page 194](#) to [Heat Section Door on Page 198](#) for additional installation information.



Figure 18S Hang pre-assembled wall sheets, window frame, and air deflector.



Figure 18T Bolt wall sheets in place. Install rolled plenum channels. Check that window frame is level and square to dryer.

Installation of Window Kits (Continued)

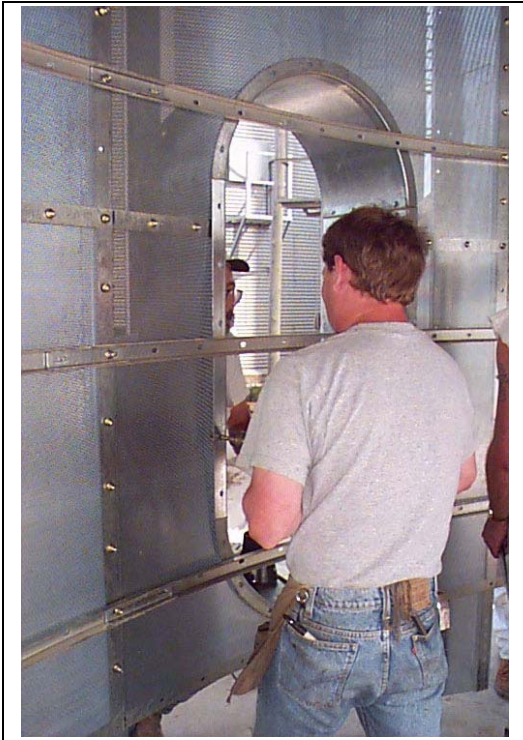

Figure 18U Install rolled plenum channels.



Figure 18W Mark outside wall sheets so they will fit inside window frame.



Figure 18X Cut outside wall sheets on inside of marked line so they will fit inside window frame. Drill bolt holes and bolt cut rolled plenum channels to window frame.



Figure 18V Drill and bolt rolled plenum channels, then cut away from window frames.

Installation of Window Kits (Continued)



Figure 18Y Fit outside wall sheets to window frame.



Figure 18Z Bolt outside wall sheets inside window frame.



Figure 18AA Bolt window frame to outside walls.

NOTE: Air deflector (arrow) is below window frame and inside outside wall sheets.

Screened Windows

See [Orientation Section on Page 32](#) for flat layout for window placement in the dryer model.

NOTE: Screened windows provide free air and cool fan motors.

Be sure each fan motor is centered in a screened window. (See [Figure 18AB.](#))

Check that 18" screened windows are level and square to dryer.

1. Pre-assemble 18" window kit as in section [Pre-assembly of Window Kits on Page 189](#). This is the window frame.
2. Install window frame to dryer as in section [Installation of Window Kits \(18" and 24"\) on Page 191](#).
3. Trim window screening to size of window frame.

Double nut screening to window with existing bolts on outside wall sheets.

Tighten bolts securely.



Figure 18AB Window is centered on fan motor.

NOTE: Window screen and outside wall sheets are not yet installed.



Figure 18AC Inside View - Screened window is centered on fan.

Screened Windows (Continued)



Figure 18AD 18" Window is installed. (Screening is not yet installed.)

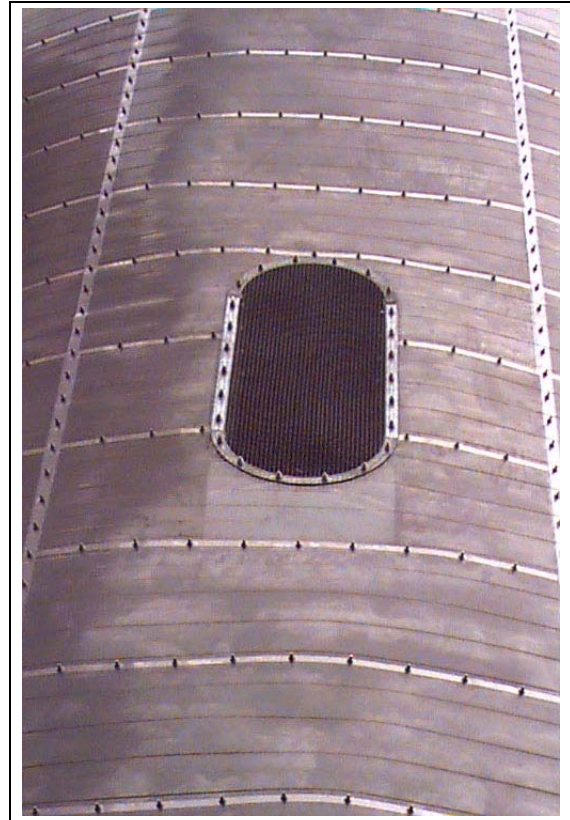

Figure 18AE Screening is installed over window. (Screen placed to outside.)



Figure 18AF Close Up - 18" Window installed. (Screening is not yet installed.)

Louvered Windows

See [Orientation Section on Page 32](#) for flat layout for window placement in the dryer model.

Check that 24" louvered windows are level and square to dryer.

1. Pre-assemble 24" window kit as in section [Pre-assembly of Window Kits on Page 189](#). This is the window frame.
2. Install window frame to dryer as in section [Installation of Window Kits \(18" and 24"\) on Page 191](#).
3. Install louvered assembly to window frame as follows.

Use 5/16" x 3/4" whiz lock bolts and nuts.

With common bolts, install latch/hinge bracket to both L.H. and R.H. sides of window frame, bolting through outside wall sheets. ([See Figure 18AG.](#))

Bolt louvered assembly to tabs on latch/hinge bracket on one side.



Figure 18AG Use common bolts on latch/hinge bracket, window frame, and outside wall sheets (arrow). Insert bolts toward inside of dryer.

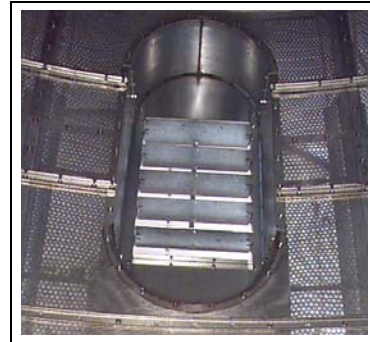

Figure 18AI Installed 24" louvered window, with louvers open.



Figure 18AJ Outsided View - Installed 24" louvered window, with louvers open.

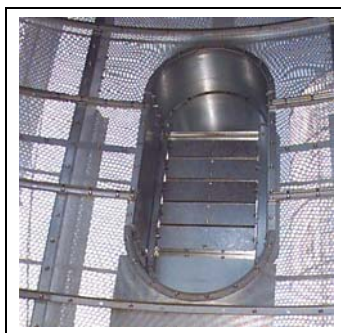

Figure 18AH Installed 24" louvered window, with louvers closed.

Cool Section Door

See [Orientation Section on Page 32](#) for flat layout, for cool section door placement in the dryer model.

Cool section door should allow comfortable step-in access to cool section.

Check that cool section door is level and square to dryer.

NOTE: *Caulking and bulb strip are not required.*

1. Pre-assemble 24" window kit as in section [Pre-assembly of Window Kits on Page 189](#). This is the cool section door frame.
2. Install cool section door frame to dryer as in section [Installation of Window Kits \(18" and 24"\) on Page 191](#).
3. Install louvered assembly to cool section door frame as follows.

Use 5/16" x 3/4" bolts and nuts.

With common bolts, install latch/hinge bracket to both L.H. and R.H. sides of window frame, bolting through outside wall sheets. ([See Figure 18AG on Page 196.](#))

Bolt louvered assembly to tabs on latch/hinge bracket on one side. Pin closed.



Figure 18AK *Cool section door is installed.*

Heat Section Door

See [Orientation Section on Page 32](#) for flat layout, for heat section door placement in the dryer model.

Locate heat section door to right of outside ladder. Center heat section door between two (2) vertical channels.

Heat section door placement should give comfortable step-in access to reducer walkway.

Check that heat section door is level and square to dryer.

1. Pre-assemble 24" window kit as in section [Pre-assembly of Window Kits on Page 189](#). This is the door frame.
2. Install door frame to dryer as in section [Installation of Window Kits \(18" and 24"\) on Page 191](#).
3. Install heat section door as follows.

NOTE: Flange on heat section door faces to outside of dryer.

Use 5/16" x 3/4" whiz lock bolts and nuts, except where noted.

Bolt hinge-door side to heat section door.

Bolt hinge-frame side to hinge-door side.

Bolt hinge-frame side to door frame.

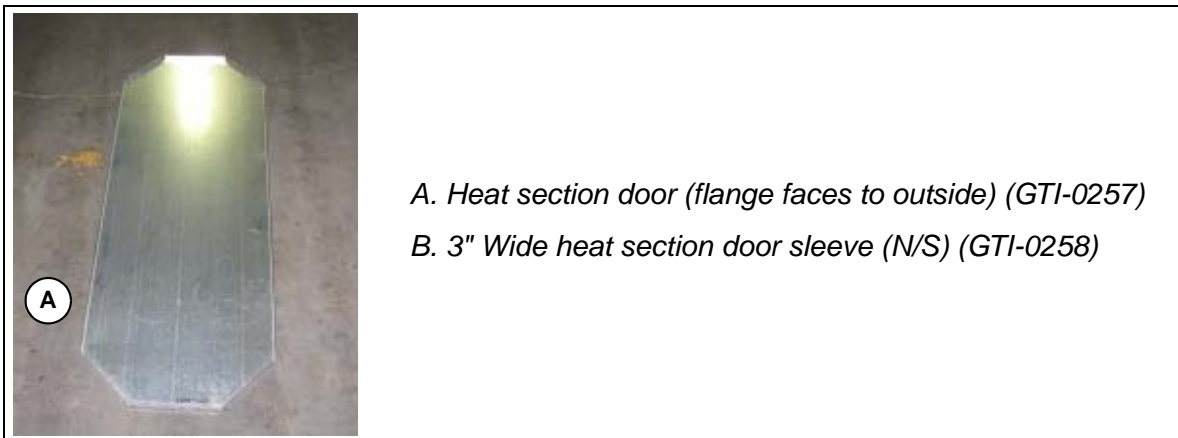

Figure 18AL

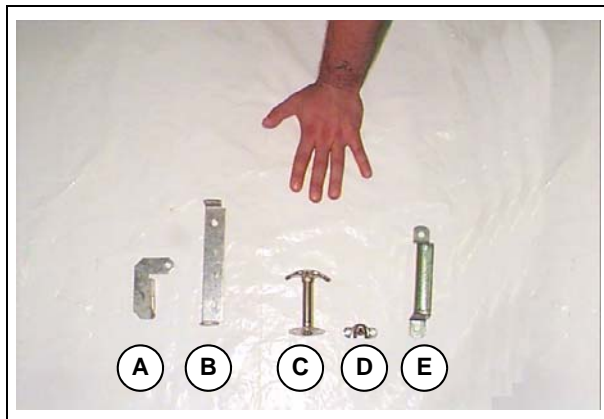

Figure 18AM

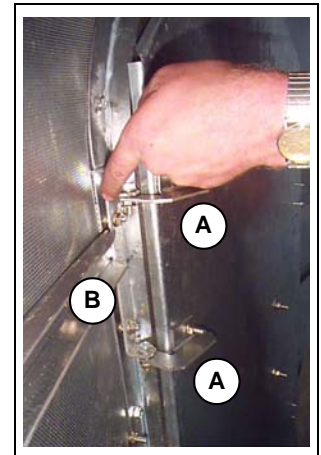

Figure 18AN

Heat Section Door (Continued)

4. Wrap 3" wide heat section door sleeve around inside of door frame. Tap hammer it around inside of door frame to fit snugly.

Open and shut heat section door to check fit of heat section door sleeve to seal door. Adjust as required.

Secure heat section door sleeve with self tapping # 10 x 1" screws.

5. Apply silicone injection caulking to seal any gaps between heat section door sleeve and door frame.

6. Press bulb seal along inside edge of heat section door sleeve.

7. Bolt door handle to pre-drilled bolt holes on outside of heat section door.

Use 5/16" x 3/4" whiz lock bolts and nuts.

8. Install door latch and hooking bracket to outside of heat section door as follows.

Use #10 x 1" self-tapping screws.



Figure 18AO *Installing 3" wide heat section door sleeve.*



Figure 18AP *Wrapping heat section door sleeve around inside of door frame.*

Heat Section Door (Continued)

Screw two (2) door latches in pre-drilled holes on outside of heat section door.

Screw two (2) hooking brackets to door frame. Position to keep heat section door tightly shut.

Check fit of heat section door in door frame, and adjust as required.



Figure 18AQ Close Up - Installing heat section door sleeve.



Figure 18AR Tap hammering heat section door sleeve around inside of door frame.



Figure 18AS Pressing bulb seal around inside edge of heat section door sleeve.

Reducer Door

Install reducer door to pre-cut opening in reducer.

Use 5/16" x 3/4" whiz lock bolts and nuts.

NOTE: *Caulking and bulb seal are not required.*

1. Snug bolt reducer door frame top, reducer door frame bottom, and two (2) reducer door frame sides to inside of pre-cut opening on reducer. Fit reducer door frame together as tightly as possible.

Check that reducer door frame is level and square. Tighten bolts.

NOTE: *Do not tighten bolts on hinge-side of reducer door frame, where reducer door assembly will be installed.*

2. Bolt door latch in pre-drilled bolt holes inside reducer.
3. Install reducer door assembly as follows.

Install hinge-side of reducer door assembly to hinge-side of reducer door frame.

Open and shut reducer door assembly to check fit in door frame. If necessary, adjust reducer door assembly.

4. Adjust bolt on door latch so reducer door latches securely.

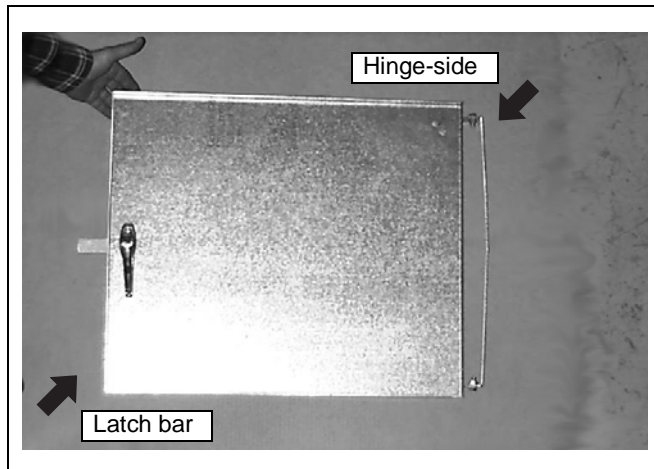

Figure 18AT *Reducer door assembly, with latch bar.
Note hinge-side.*

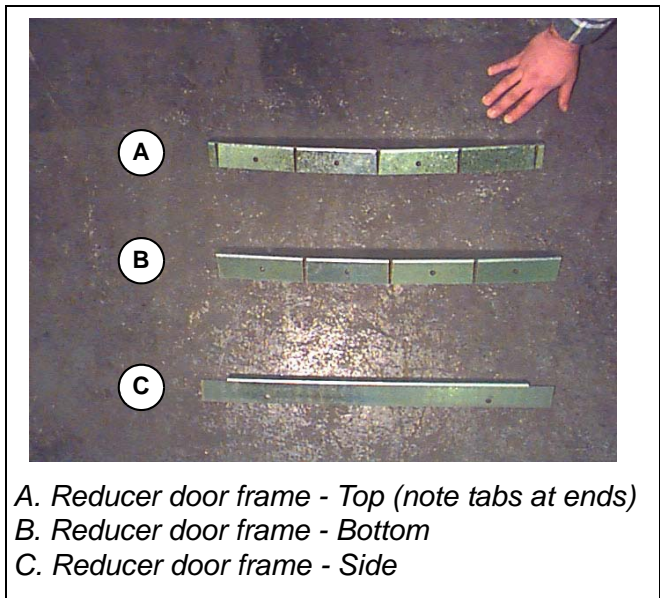

Figure 18AV
A. Reducer door frame - Top (note tabs at ends)
B. Reducer door frame - Bottom
C. Reducer door frame - Side

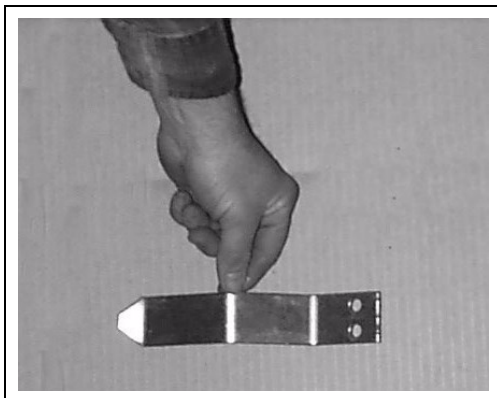

Figure 18AU *Door Latch*

Reducer Door (Continued)



Figure 18AW Bolting door latch in pre-drilled bolt holes inside reducer.

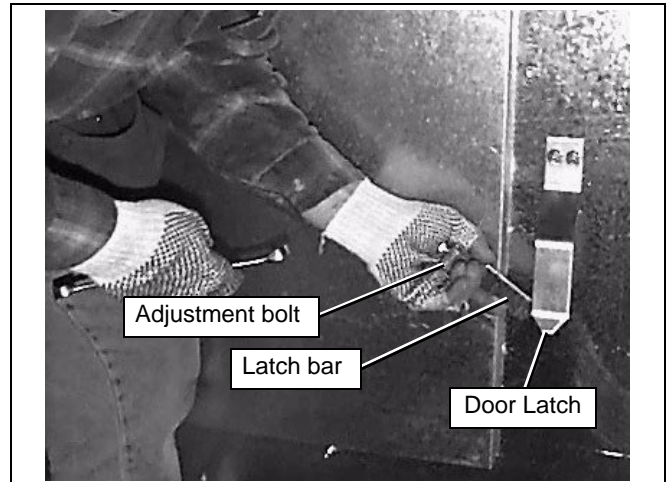

Figure 18AY Checking latch on reducer door

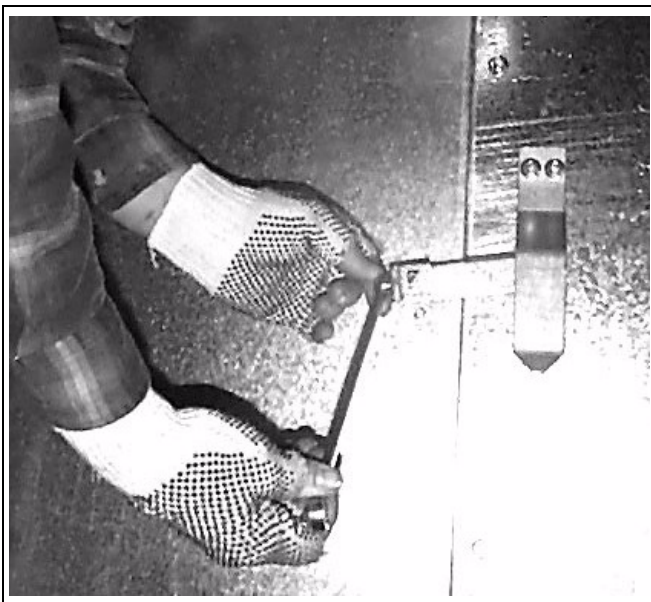

Figure 18AX Adjusting bolt on latch bar.

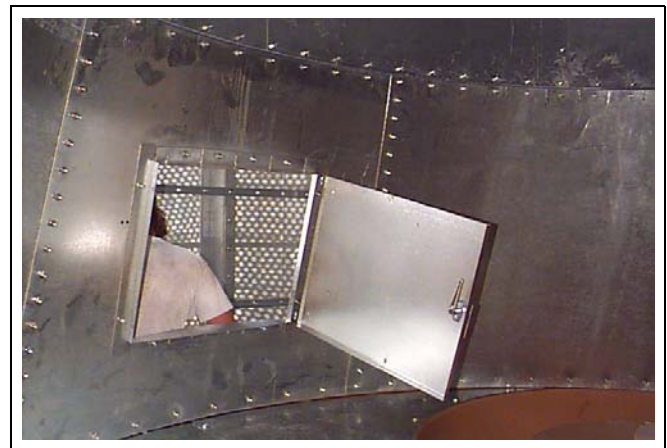

Figure 18AZ Reducer door is installed.
NOTE: Hinges are on R.H. side in this example.



Figure 18BA Reducer door is installed.
NOTE: Hinges are on L.H. side in this example.

Reducer Door (Continued)



Figure 18BB *Front of installed reducer door.*

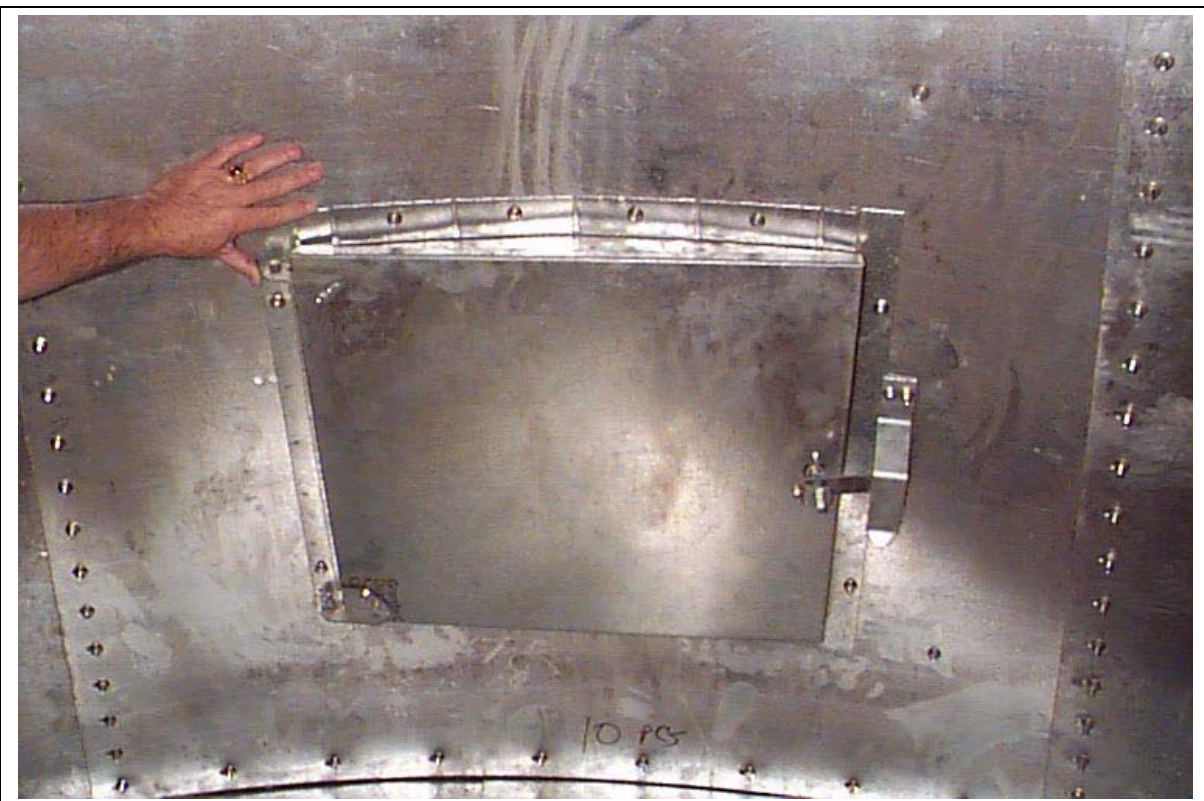

Figure 18BC *View Inside Reducer - Reducer door is installed and latched.*

Compression Angle Weldments Example - All Models

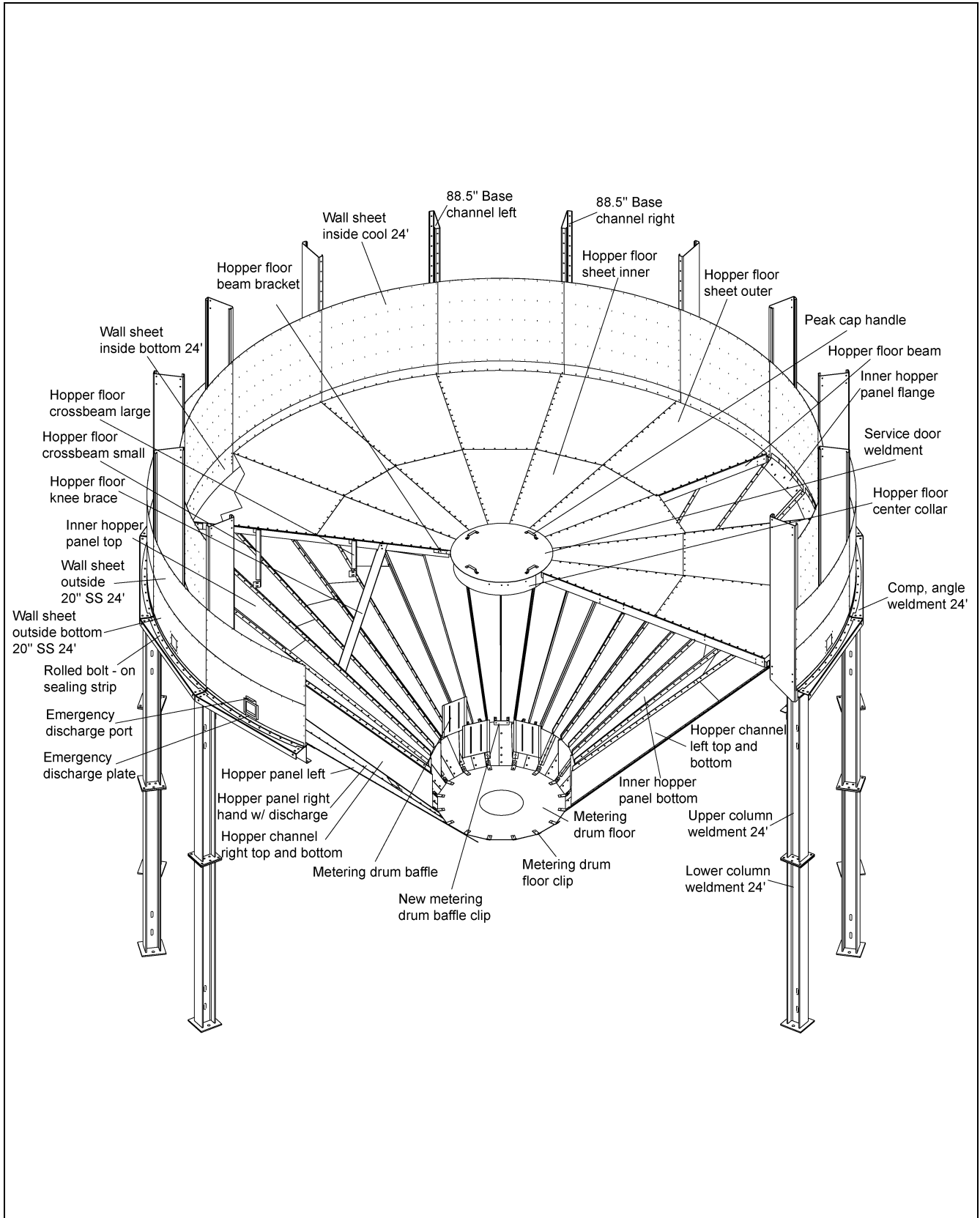

Figure 19A

Dryer Legs Example - All Models

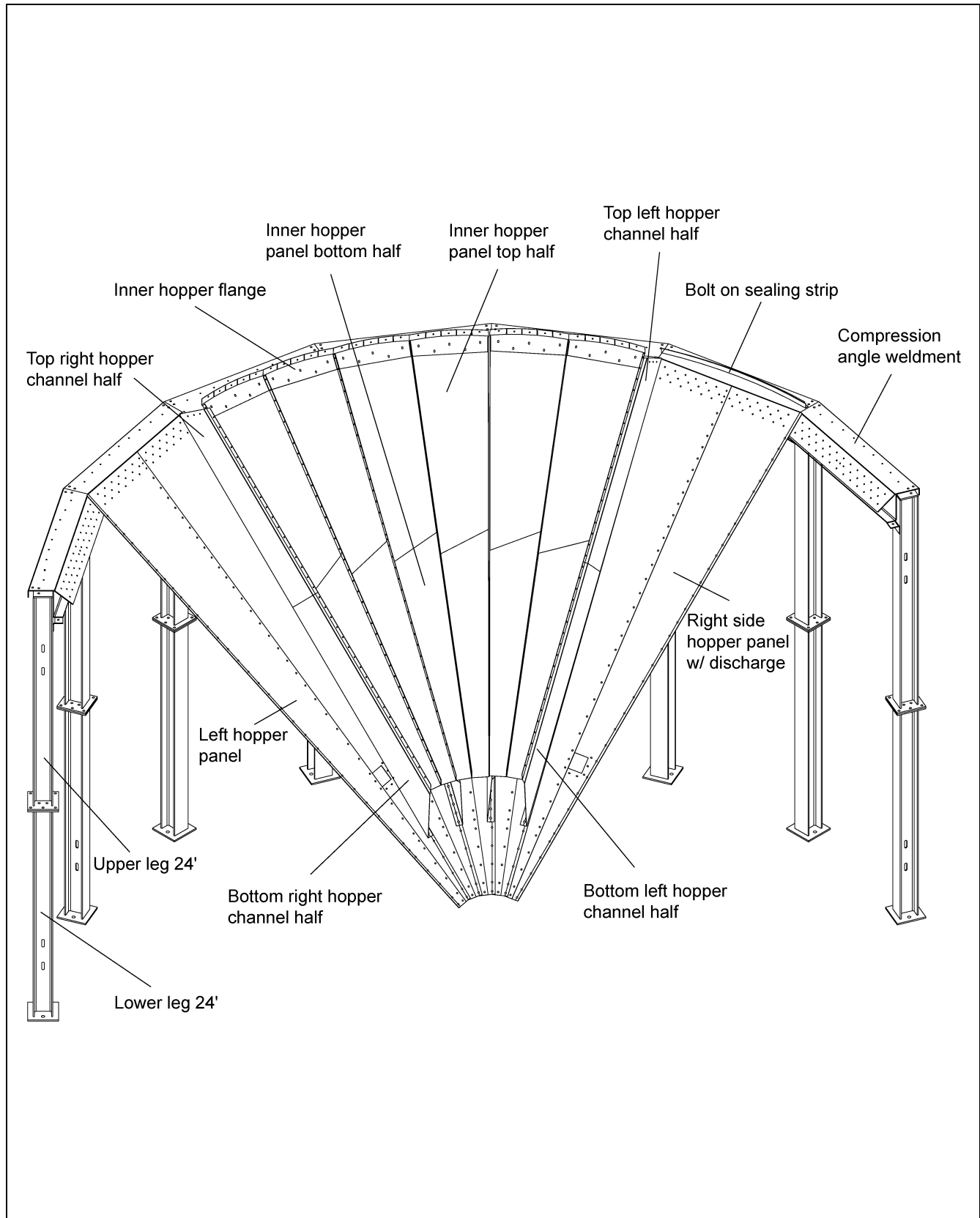

Figure 19B

19. Tower Base



Important Safety Precautions:

**Dryer has sharp edges. These sharp edges may cause serious injury.
Use appropriate personal protective equipment. Use proper lifting techniques.**

See [Orientation Section on Page 19](#) for dryer dimensions, components, wall sheet guidelines, etc.
See [Appendix A on Page 435](#) for tools and equipment, [Appendix B on Page 437](#) for hardware, etc.

Vertical base channels, solid wall sheets, sealing strip, base stiffener weldments, compression angle weldments, cool section floor beam brackets, legs, and X-bracing rods.

X-Bracing Rod Placement Example - All Models

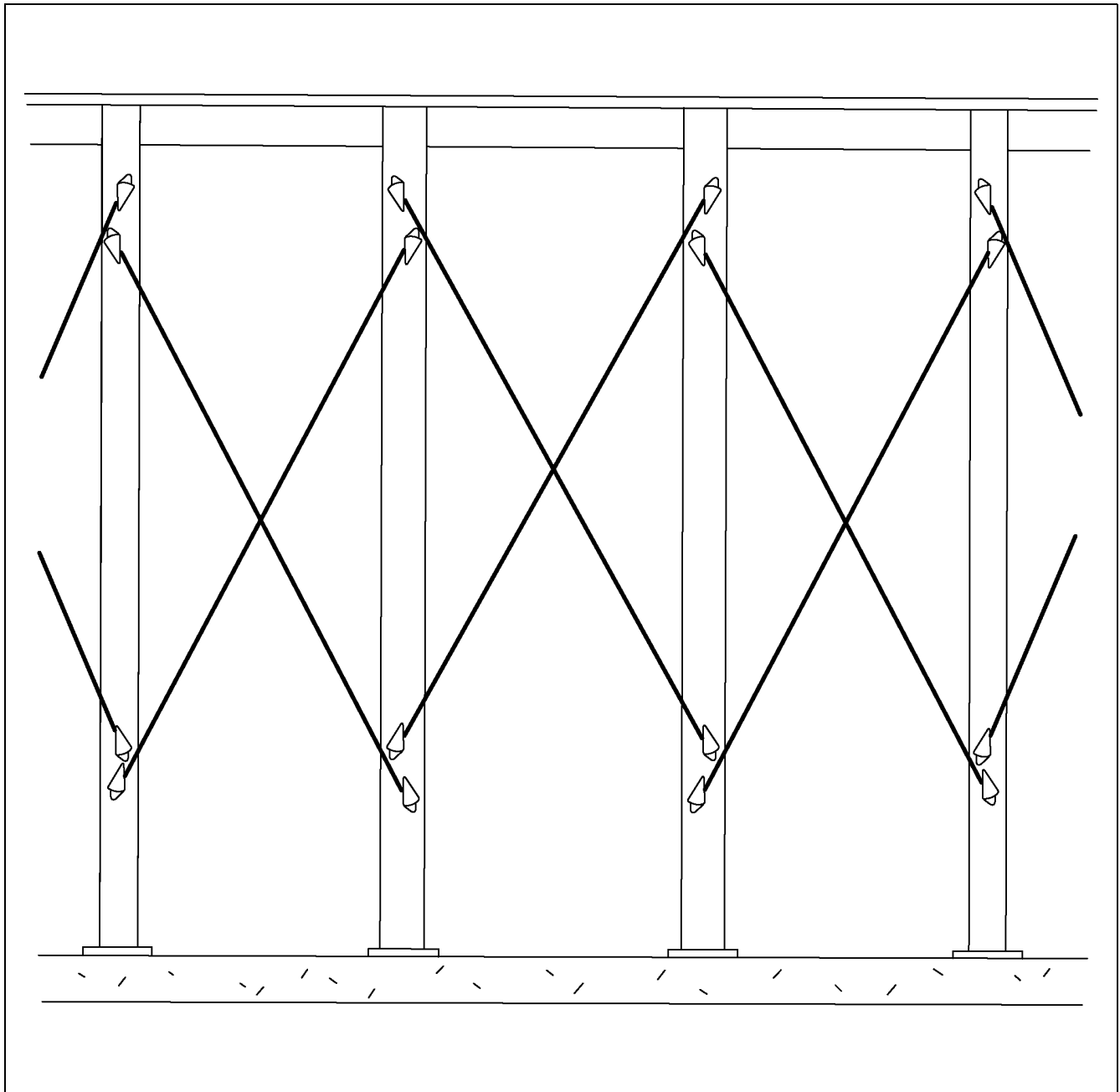

Figure 19C

Vertical Base Channel Right and Left Kits

Install R.H. vertical base channels and L.H. vertical base channels to bottom of vertical channel columns. Bottom of vertical base channel is angled. Attach short side of vertical base channel to jig clip with jig clip extender. (See [Figure 19E.](#)) Kits designed to shorten jack lift, improve safety.

Outside Solid Wall Sheets

Last ring of outside wall sheets and inside wall sheets on dryer are solid. See [Orientation Section on Page 19](#) for assembly layout for placement.

Install outside solid wall sheets at base of dryer.

NOTE: After compression angle weldment is installed in later step, install inside solid wall sheets at base of dryer.

Sealing Strip

Bolt sealing strip (See [Figure 19F](#) and [Figure 19G.](#)) to bottom of outside solid wall sheets.

Use 5/16" x 3/4" whiz lock bolts and nuts.

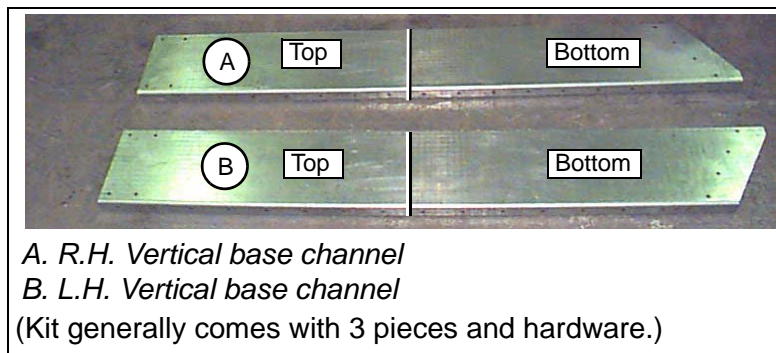

Figure 19D



Figure 19E Use jig clips extenders (arrow) to attach vertical base channel to jig clip.



Figure 19F Sealing Strip

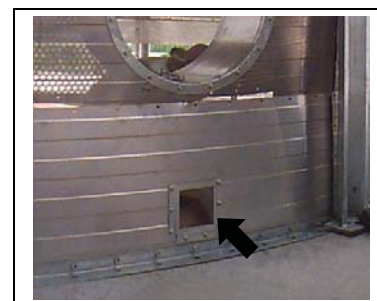

Figure 19G Sealing strip (arrow) is installed to bottom of outside solid wall sheets.

Base Stiffener Weldment

Bolt base stiffener weldment to each vertical base channel (with common bolts through outside wall solid sheets).

(See Figure 19H, Figure 19I and Figure 19J.)

Use 3/8" x 1-1/2" grade 8 bolts and nuts.

Insert bolts toward outside of dryer.



IT IS IMPORTANT TO POSITION BASE STIFFENER WELDMENT CORRECTLY.

Entire weight of dryer transfers from columns of vertical channels through base stiffener weldments to dryer legs. Position base stiffener weldments over sealing strip and flush to foundation.

Check that base stiffener weldment is flush (level and even) with vertical base channel.



Figure 19H Base stiffener weldments as shipped.



Figure 19I Positioning base stiffener weldment flush over vertical base channel (that is under outside solid wall sheets.)



Figure 19J Tightening base stiffener weldment to vertical base channel.

NOTE: Base stiffener weldment is flush to foundation.

Compression Angle Weldments

See [Figure 19A on Page 204](#) and [Figure 19B on Page 205](#) for placement of compression angle weldments. From outside dryer, bolt compression angle weldment to sealing strip. (See [Figure 19L](#), [Figure 19M](#) and [Figure 19N on Page 210](#).)

Use 5/16" x 1" bolts, nuts, and washers.

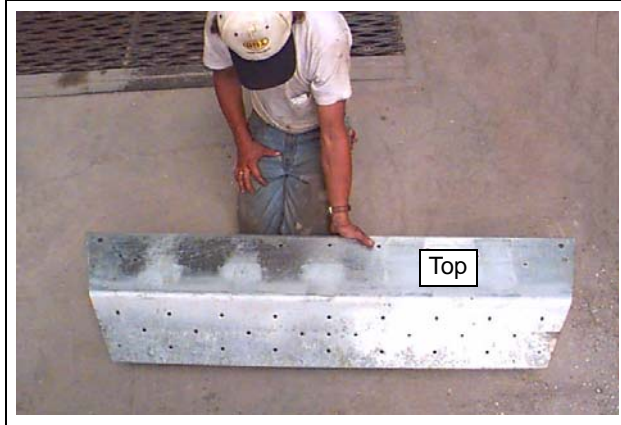

Figure 19K Compression Angle Weldment



Figure 19L Bolting compression angle weldments to bottom of sealing strip.

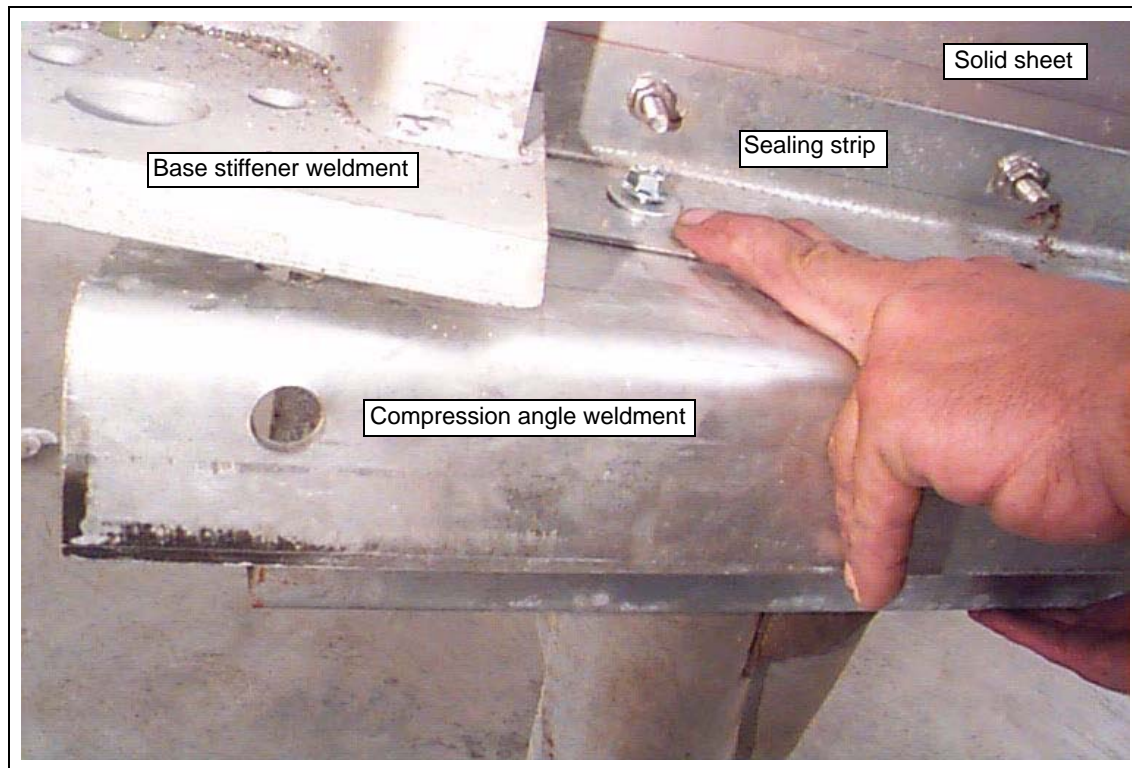

Figure 19M Close Up - Bolting compression angle weldments to sealing strip. Trim sealing strip if required.

Compression Angle Weldments (Continued)



Figure 19N Compression angle weldments encircle base of dryer.



Figure 19O Inside view - Installing compression angle weldments.

NOTE: Inside solid wall sheet will be installed after compression angle weldment, with one rolled plenum channel in 4th bolt hole.

Upper Legs

See [Figure 19A on Page 204](#) and [Figure 19B on Page 205](#) for placement of upper legs. Install upper legs with support clip side to inside of dryer.

Outside dryer - Bolt upper leg through compression angle weldment to base stiffener weldment. (See [Figure 19S on Page 212.](#))

Use 5/8" x 2-3/4" grade 8 bolts and nuts.

Inside dryer - Bolt support clip on upper leg to compression angle weldment. (See [Figure 19T on Page 212.](#))

Use 5/8" x 1-1/2" grade 8 bolts and nuts.

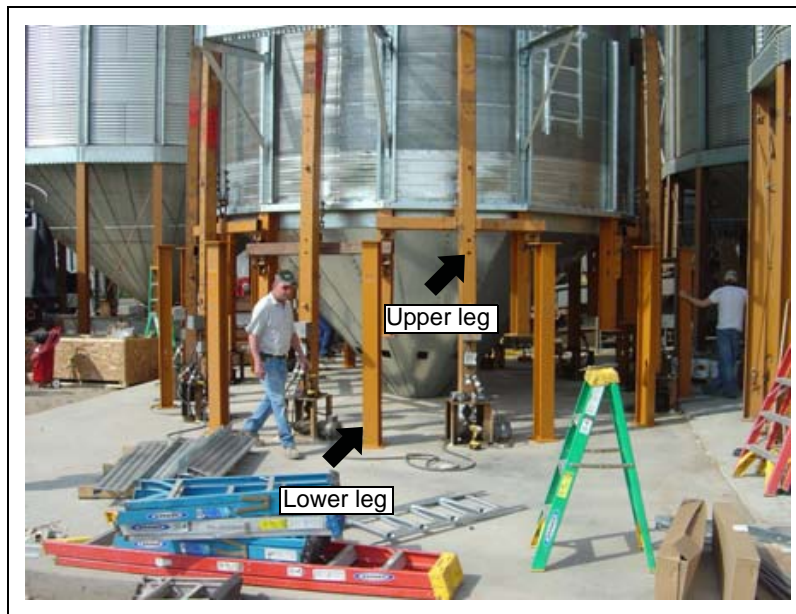

Figure 19P



Figure 19Q Aligning upper leg to base stiffener weldment.



Figure 19R Placing upper leg directly under base stiffener weldment.

Upper Legs (Continued)

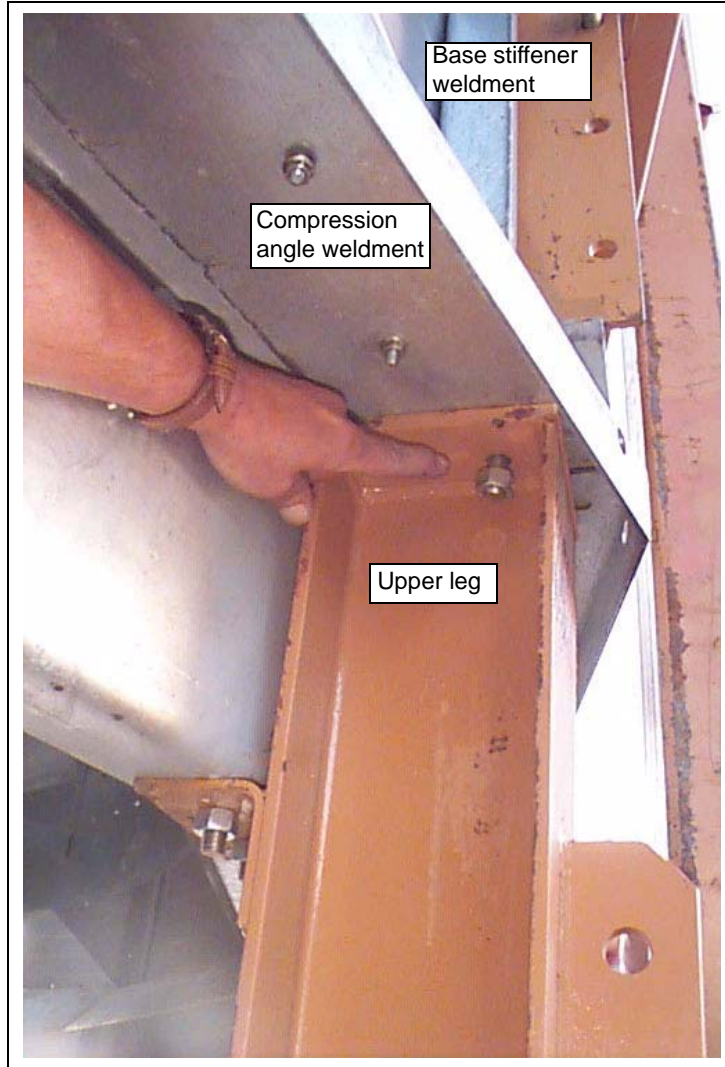

Figure 19S Underside View - Upper leg is bolted through compression angle to base stiffener weldment.

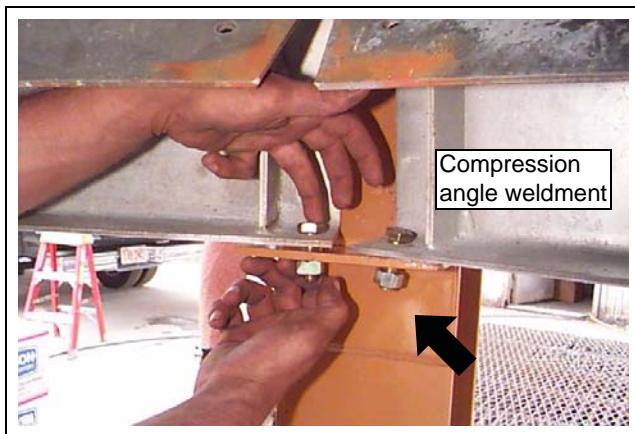

Figure 19T Bolting support clip on upper leg (arrow) to compression angle weldment.



Figure 19U Upper legs are installed.

Lower Leg

Lower legs are installed **AFTER** outside hopper panels are installed.

See [Figure 19B on Page 205](#) for placement of lower legs.

Bolt lower leg directly below each upper leg. Use two (2) 5/8" x 2" grade 8 bolts, two (2) 5/8" nuts, and two (2) 3/4" washers. Insert bolts down, with one (1) washer above and one (1) washer below flange on legs.



Figure 19V Bolting lower leg to upper leg.

Adjust Dryer to Round and Vertical

Dryer must be round at the base and vertical along its entire length.

All 18' dryers are 9"-1" from center to middle of leg. Measure each leg and adjust as necessary to bring legs into position.

Adjust dryer as required to make entire length of dryer vertical.

(See [Figure 19W](#) and [Figure 19X on Page 214.](#))



IT IS IMPORTANT ENTIRE LENGTH OF DRYER IS VERTICAL.

Vertical is perpendicular to the horizon.

Check by sighting dryer from distance. Also measure with level transit, surveyor's level transit, or plumb line.

Adjust Dryer to Round and Vertical (Continued)

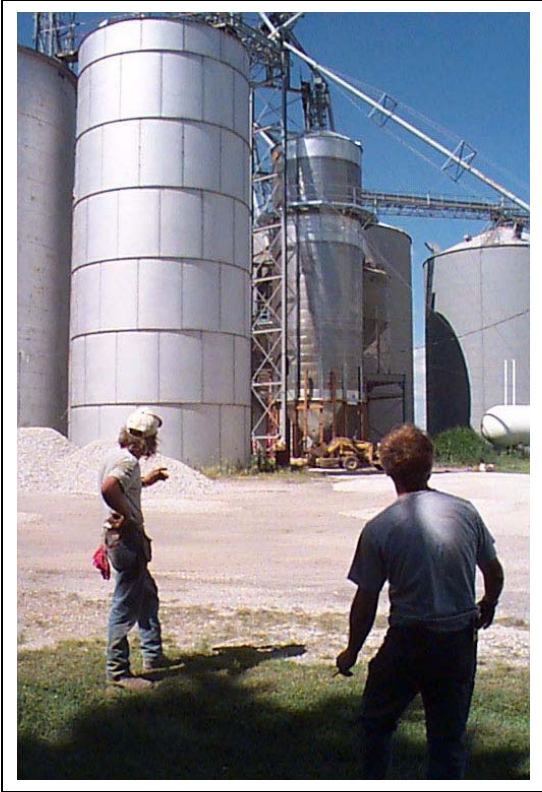

Figure 19W Sighting from a distance to check entire length of dryer is vertical.



Figure 19Y Winching dryer legs into position.



Figure 19X Tapping dryer legs into position.

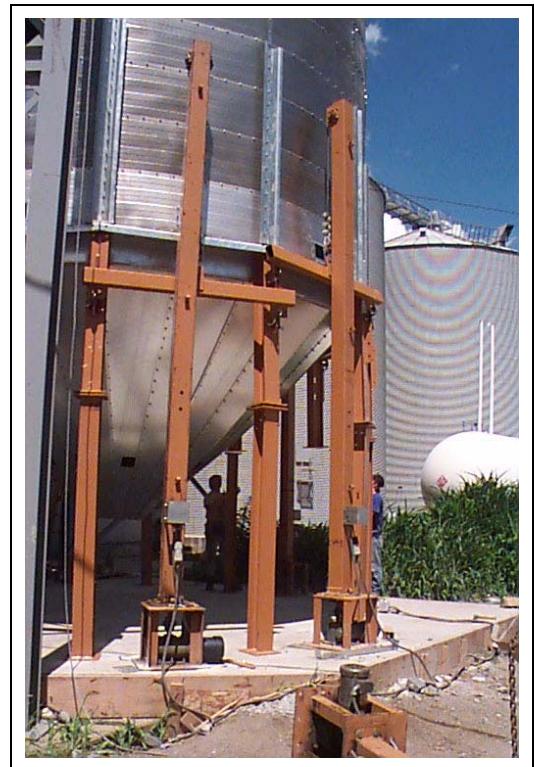

Figure 19Z Dryer legs are installed. Dryer is round and vertical.

Anchoring Dryer Legs

When dryer is round and vertical, anchor lower legs to dryer foundation as follows.

Use supplied HILTI HAS anchor bolts.

IMPORTANT: *Drill out bolt holes in base of lower leg. See manufacturer's instruction sheet for proper size hole to securely anchor dryer.*

Install bolts to bolt holes at base of lower leg with ceramic epoxy.

IMPORTANT: *Apply ceramic epoxy and set anchor bolts according to manufacturer's instructions. See manufacturer's MSDS (Material Safety Data Sheet) for safety hazards and precautions.*



Figure 19AA Hammer Drill and Bit



Figure 19AC Ceramic Epoxy Injection Tool Cartridge



Figure 19AB Ceramic Epoxy Injection Tool



Figure 19AD Ceramic Epoxy Injection Tool Nozzle

Follow Manufacturer's Instructions to Apply Ceramic Epoxy



Figure 19AE Drill proper size hole.



Figure 19AG Fill hole with ceramic epoxy.

IMPORTANT: Thoroughly clean all debris out of drilled hole for proper epoxy adhesion.



Figure 19AF Clean Out Hole

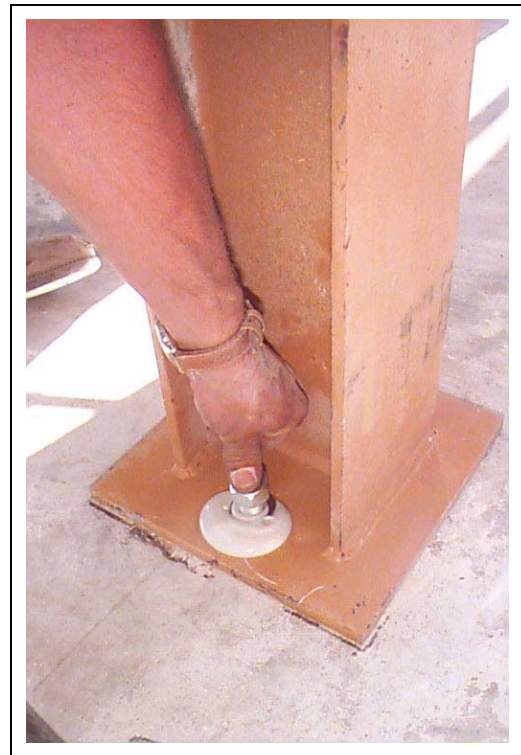

Figure 19AH Insert HILTI HAS anchor bolt. Move bolt up and down several times to remove air pockets from epoxy.

X-Bracing Rods

See [Figure 19C on Page 206](#) for X-bracing rods for placement.

Secure X-bracing rods to dryer legs with 3/4" nut, 3/4" washer, and cast washer as shown in [Figure 19AL on Page 218](#).



Figure 19AI Installing X-bracing rods to dryer legs



Figure 19AJ X-Bracing Rods



Figure 19AK Cast Washer

X-Bracing Rods (Continued)

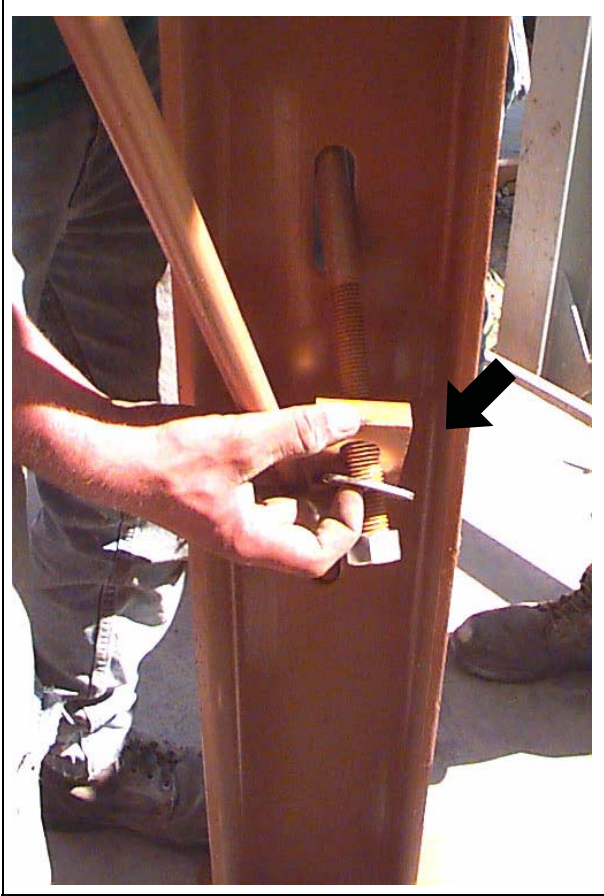

Figure 19AL Secure X-bracing rods with 3/4" nut, 3/4" washer, and cast washer (arrow).



Figure 19AM X-Bracing rods installed.



Important Safety Precautions:

**Dryer has sharp edges. These sharp edges may cause serious injury.
Use appropriate personal protective equipment. Use proper lifting techniques.**

See [Orientation Section on Page 19](#) for dryer dimensions, components, wall sheet guidelines, etc.
See [Appendix A on Page 435](#) for tools and equipment, [Appendix B on Page 437](#) for hardware, etc.

Rolled Plenum Channels

Bolt last ring of rolled plenum channels on inside solid wall sheet, above cool section floor beam brackets in pre-drilled bolt holes. (See [Figure 20A](#).)

NOTE: This ring of rolled plenum channels is outer edge of support for cool section floor sheets.



Figure 20A

NOTE: Tighten bolts in cool section floor after hopper and metering drum are installed.

When tightening bolts in cool section floor, start at center of each floor sheet and work to edges to avoid buckling.

Caulking

After hopper and metering drum are installed, run a bead of silicone injection caulking around (top) outside edge hopper. Fill gaps between cool section and inside wall of dryer.

A good seal is important to reduce dust in cool section.



Figure 20B *Moving metering drum into center of dryer.*



Figure 20C *Caulking outside edge of hopper.*

Hopper (Cross Section) Example - All Models

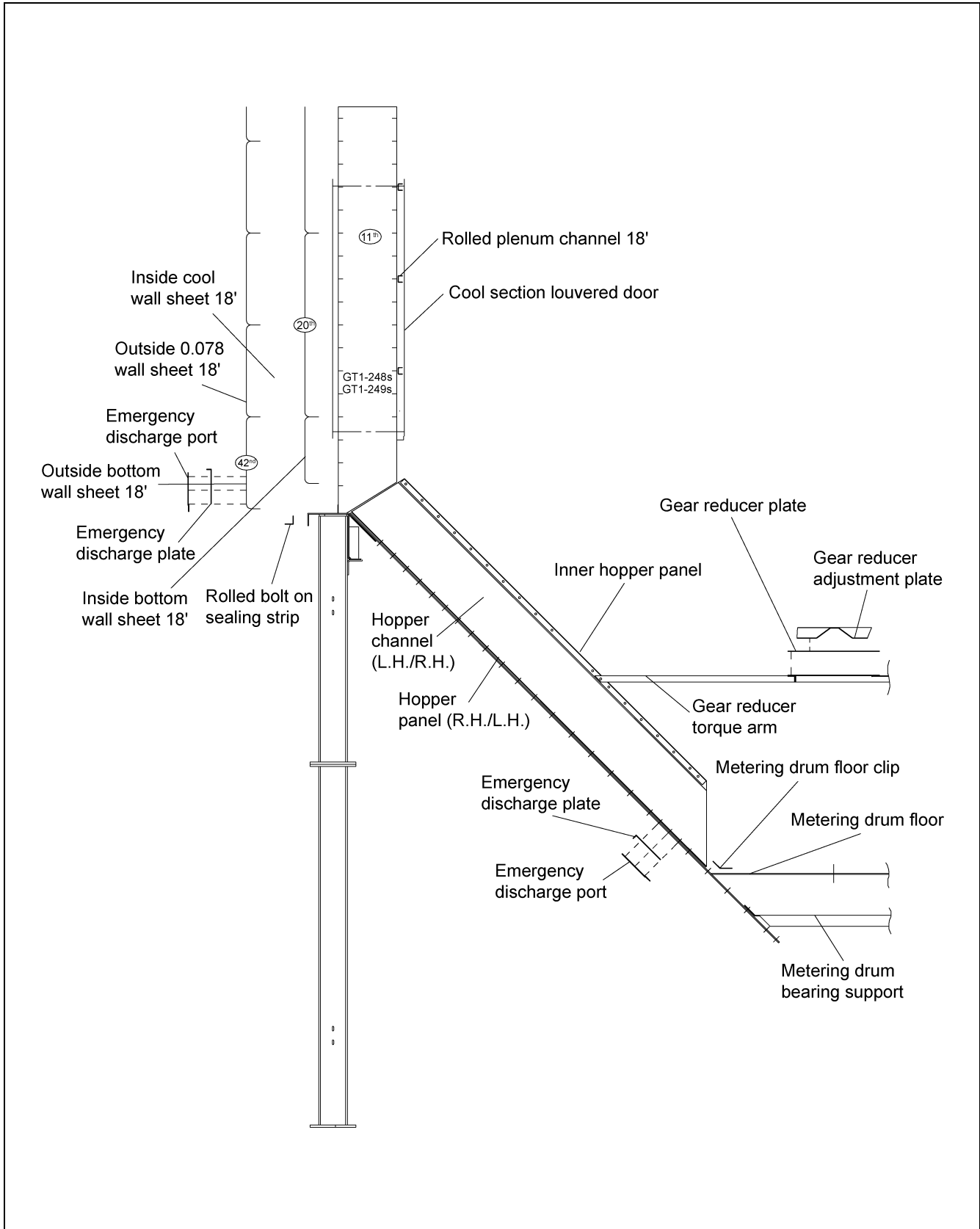

Figure 21A

Hopper (Cross Section) Example - All Models (Continued)



Important Safety Precautions:
 Dryer has sharp edges. These sharp edges may cause serious injury.
 Use appropriate personal protective equipment. Use proper lifting techniques.

See [Orientation Section on Page 19](#) for orientation for dryer dimensions, components, wall sheet guidelines, etc. See [Appendix A on Page 435](#) for tools and equipment, [Appendix B on Page 437](#) for hardware, etc.

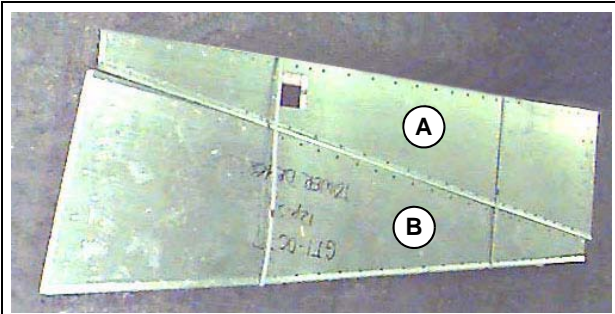

A. Outside hopper panel-R.H. with cut out for slide gate (for emergency grain discharge).
 B. Outside hopper panel-L.H.

Figure 21B

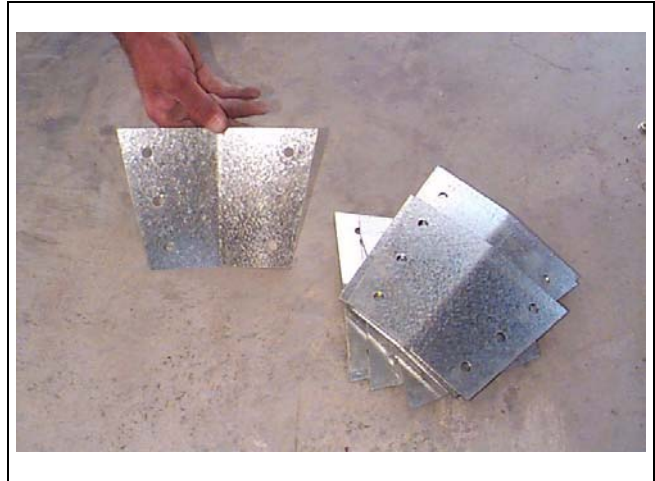

Figure 21C Compression Angle Splices

1. Lapping outside hopper panels.
2. Lap outside hopper panel-R.H. with cut out on outside of dryer so slide gate will slide freely.
3. Outside hopper panels flat edges - Lap together and bolt.
4. Outside hopper panels angled edges - Lap together, then bolt under hopper channels with common bolts.



Figure 21D Hopper channels, R.H. and L.H. install with diagonal-cut end down. Bottom side has horizontal flange. Top side has vertical flange.

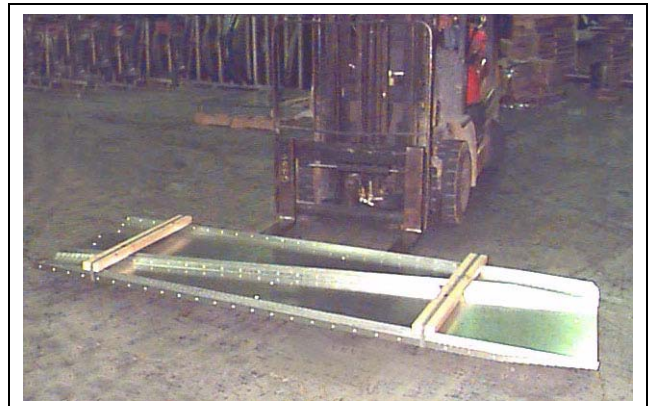

Figure 21E Inside Hopper Panels (under wood shipping blocks).

Hopper (Cross Section) Example - All Models (Continued)

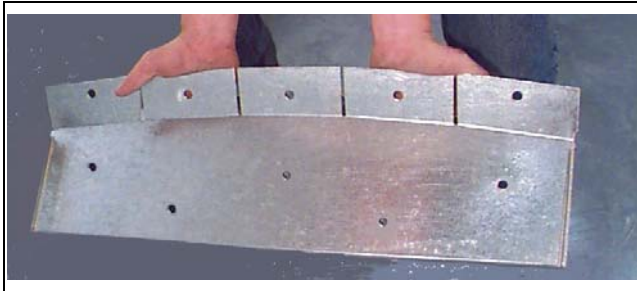

Figure 21F *Inside Hopper Flange*



Figure 21G *Hopper Discharge Weldment*

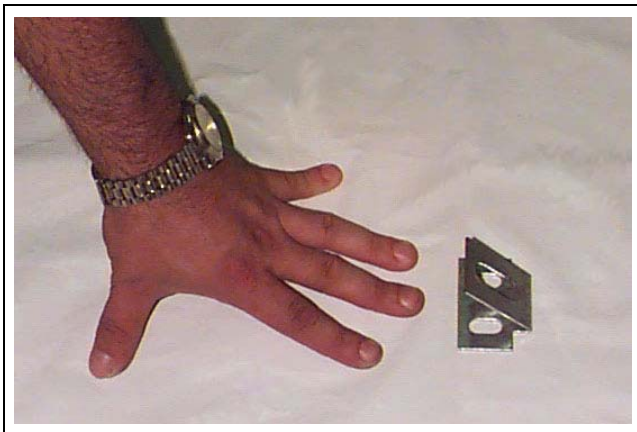

Figure 21H *Metering Drum Floor Clip*



Figure 21I *Metering Drum Floor*



Figure 21J *Metering Drum Bearing Support*

Hopper (Cross Section) Example - All Models (Continued)



Insert bolts away from hopper, with head of bolt between outside and inside hopper panels.

Until fully installed, secure outside hopper against wind, especially overnight.

Hopper Parts	Hardware and Installation Notes
Outside hopper panels (R.H./L.H.) compression angles and through compression angle splices.	3/8" x 1", Grade 5 bolts and nuts. (See photos for additional installation notes.) (Lift dryer to free outside hopper panels.)
Outside hopper panel (L.H./R.H.) seams.	1/2" x 1", Grade 5 bolts and nuts. (Install L.H. and R.H. panels in pairs that mirror each other. First bolt every other seam, in other words, bolt flat edged seams. Channels will bolt over angled edge seams with common bolt.) (Gather lower edges of panels and secure with temporary bolts.) (Install lower legs.)
Metering drum bearing support. Metering drum floor clips. Metering drum floor.	3/8" x 1", Grade 5 bolts and nuts. (Level and drill for outside bolts.) (Center bolt is common with outside hopper panel seam.) 1/2" x 1", grade 5 bolts and nuts. (Install on panel seams.) 1/2" x 3/4" slotted truss head bolts and 5/16" whiz lock nuts. (Install to clips and level.) (Silicone caulk metering drum floor.)
Hopper discharge weldment to outside hopper panels.	1/2" x 1", Grade 5 bolts and nuts. (Bolt tight. Tighten bottom four bolts on outside hopper panels seams while accessible.)
Hopper channels (R.H./L.H.) to outside hopper panels (R.H./L.H.).	1/2" x 1", Grade 5 bolts and nuts. (Install L.H. and R.H. hopper channels in pairs that bracket each other. Match shape of hopper channel to vertical base channel for smooth transition from grain column to hopper.) (Tighten outside hopper.) (Silicone caulk gap between hopper panels at compression angles, and along vertical length of compression angle splices.)
Pre-assemble one (1) inside hopper flange to each inside hopper panel.	5/16" x 3/4" Whiz lock bolts and nuts.
Inside hopper panels to hopper channels.	3/8" x 1", Grade 5 bolts and nuts.
Inside hopper flange to inside solid wall sheet.	5/16" x 3/4" Whiz lock bolts and nuts. (Bolt tight.)
Slide gate frame to outside hopper panel-R.H.	5/16" x 3/4" Whiz lock bolts and nuts.
Slide gate panel.	Insert in slide gate frame.

Hopper (Cross Section) Example - All Models (Continued)

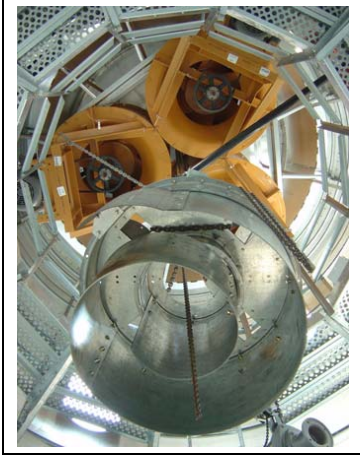

Figure 21K Metering drum is hoisted before hopper is installed. **NOTE:** Access opening in cool section floor (arrow).



Figure 21N View from below - Bolting outside hopper panels over compression angles and compression angle splices.



Figure 21L In photo, to demonstrate orientation, compression angle splice (arrow) is temporary bolted to compression angles. In actual installation, use common bolt to install outside hopper panels (over compression angle splice) to compression angles.

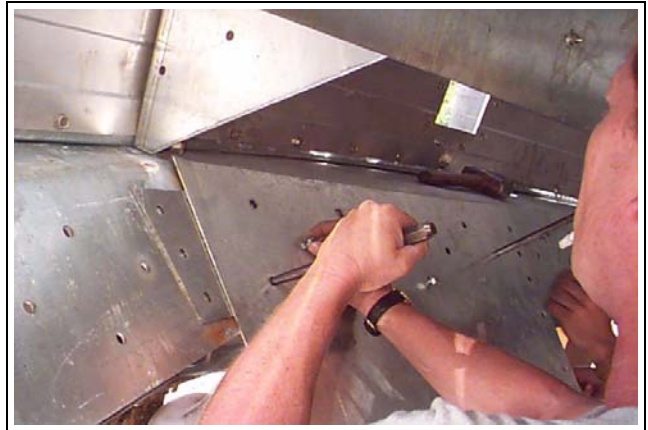

Figure 21O Close Up - Aligning outside hopper panels over compression angles and compression angle splice (arrow).



Figure 21M View from above - Bolting outside hopper panels over compression angles and compression angle splices.



Figure 21P Aligning Outside Hopper Panels

Hopper (Cross Section) Example - All Models (Continued)



Figure 21Q While installing outside hopper panels, allow ends to overlap at center of dryer.



Figure 21T Bring metering drum floor into outside hopper before closing in with last panel.

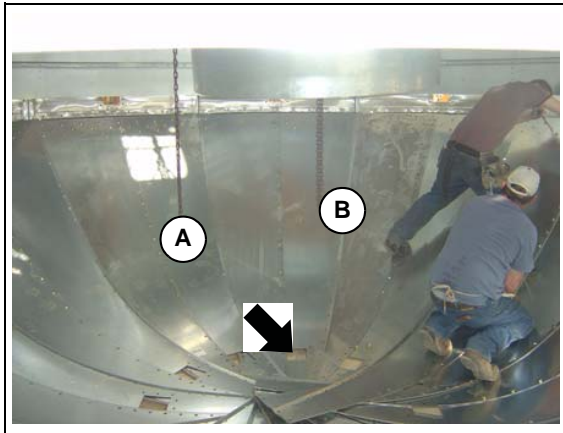

Figure 21R Close Up - Bolting outside hopper panels (R.H./L.H.). Lap outside hopper panels-R.H. with cut out (arrow) on outside of dryer so slide gate will slide freely.

- A. Bolt flat edges together.
- B. Angled edges will bolt together later, under hopper channel with common bolt.



Figure 21U

IMPORTANT: After all outside hopper panels are in place, secure against wind with temporary bolts, especially overnight.



Figure 21S Installing outside hopper panels.



Figure 21V Aligning outside hopper panels before installing hopper discharge weldment.

Hopper (Cross Section) Example - All Models (Continued)

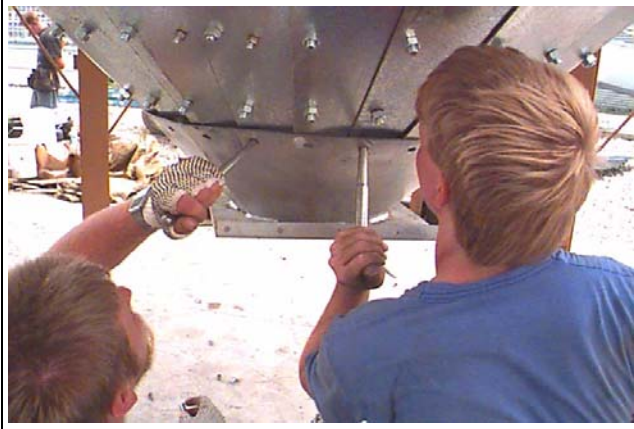

Figure 21W Aligning hopper discharge weldment to outside hopper panels.



Figure 21Z Installing metering drum floor to underside of metering drum floor clips. Check for level.



Figure 21X Drilling two (2) outside bolt holes at each end of metering drum bearing support. **NOTE:** Center bolt hole (arrow) is bolted with common bolt to a flat edged outside hopper panel seam. Check for level.



Figure 21AA Close Up - Installing metering drum floor to metering drum floor clips.

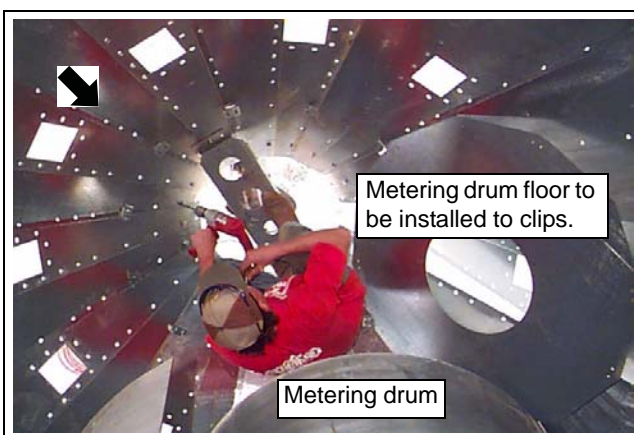

Figure 21Y Installing metering drum floor clips (arrow) around bottom perimeter of outside hopper.



Figure 21AB Caulking metering drum floor with silicone caulk.

Hopper (Cross Section) Example - All Models (Continued)



Figure 21AC Bringing hopper channels (R.H./L.H.) into dryer through opening in cool section floor.



Figure 21AF View from below - Installing R.H. and L.H. hopper channels.



Figure 21AD View from above - R.H. and L.H. hopper channels bracket each other (arrow).



Figure 21AG Snug bolt all R.H./L.H. hopper channels in place, then tighten.



Figure 21AE View from above - Installing R.H. and L.H. hopper channels to bracket each other.



Figure 21AH Pre-assembling one (1) inside hopper flange to each inside hopper panel.

Hopper (Cross Section) Example - All Models (Continued)

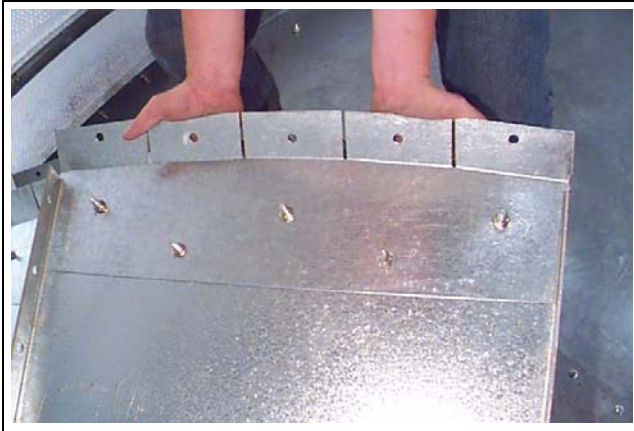

Figure 21AI Close Up - Inside hopper flange bolted to inside hopper panel.



Figure 21AJ Self - Tapper inside hopper flange to inside solid wall sheet.

After installing inside hopper panels, bolt the new style cooling floor brackets on to hopper sheets using 5/16"-1" bolts. Be sure that the four (4) notched brackets are evenly spaced. Inside hopper and floor brackets can be tightened.

Install ladder to hopper panels using 5/16" bolts and nuts. Using outside ladder standoff, ladder must be attached to hopper where the inside catwalk door is located.

Next install the grain flow gates to the hopper channels, just below the inner hopper, the bottom bolts in the center set of holes. Use 5/16" bolts, tighten after installing.



Figure 21AK Bolting cool section floor support to cool section floor beam.



Figure 21AL Hopper installed with emergency discharge slide gates. (See Slide Gates on Page 140.)

Metering System Example - All Models

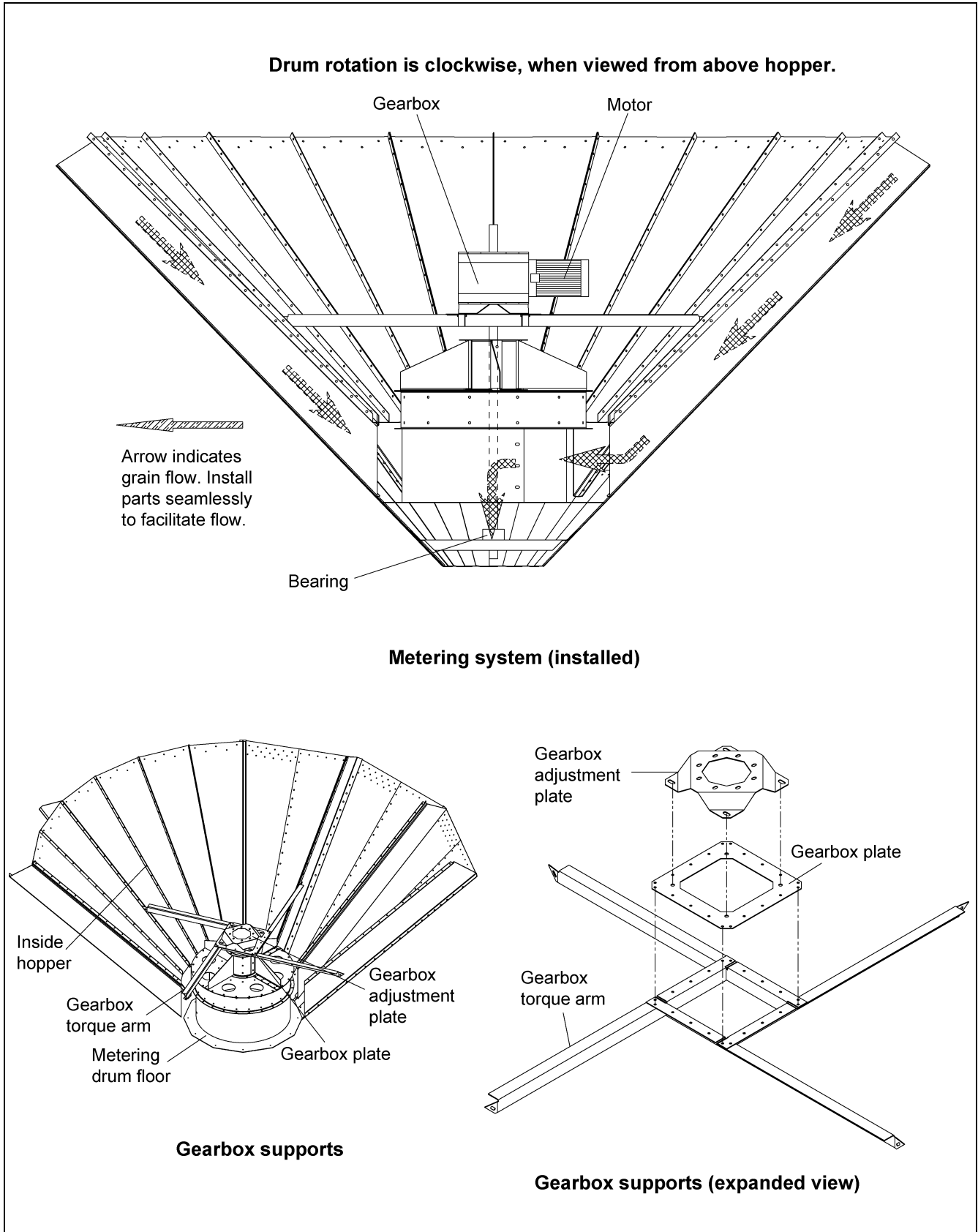

Figure 22A



Important Safety Precautions:
 Dryer has sharp edges. These sharp edges may cause serious injury.
 Use appropriate personal protective equipment. Use proper lifting techniques.

See [Orientation Section on Page 19](#) for dryer dimensions, components, wall sheet guidelines, etc.
 See [Appendix A on Page 435](#) for tools and equipment, [Appendix B on Page 437](#) for hardware, etc.



Figure 22B Metering Drum



Figure 22D Metering Drum Bearing



Figure 22E Gearbox Torque Arm



Figure 22C Metering drum motor as shipped.

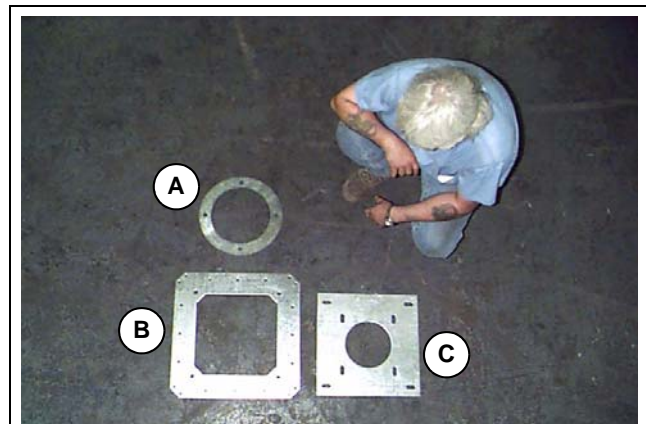

- A. Gearbox adapter plate
- B. Gearbox plate
- C. Gearbox adjustment plate

Figure 22F

22. Metering System



Figure 22G Metering drum drive shaft weldment 6' (2-3/8").
NOTE: Grain deflector (arrow) is over bearing thrust collar.

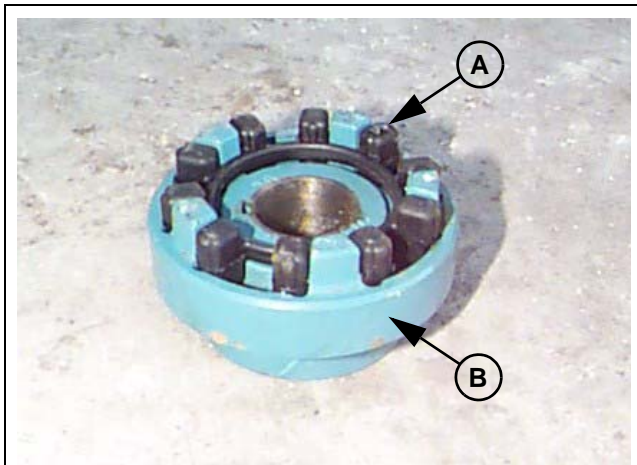

A. Motor shaft coupling insert
B. Motor shaft coupling body

Figure 22H Half of flexible coupler - 2 parts. (Other half of flexible coupler is pre-installed on gearbox.)



Figure 22I Gearbox Set Collar 2-3/8"

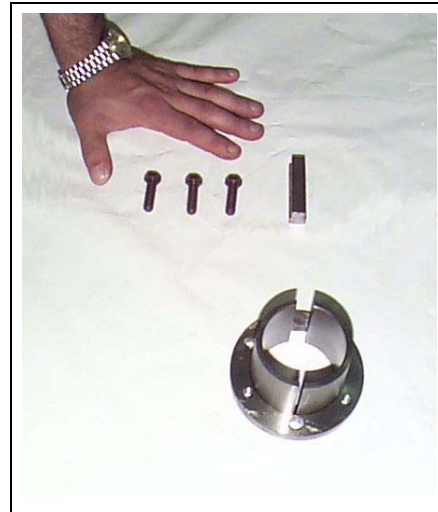

Figure 22J Q1 Taper bushing with 2-3/8" bore, key and set screws.



Figure 22K Amoco perma gear 220 or equivalent lubricant for gearbox. (5 Gallon.)

Metering System

1. Remove any burrs, pits, and corrosion from metering drum drive shaft weldment. *(See Figure 22L.)*
2. Slide metering drum bearing on metering drum drive shaft, flush with bearing thrust collar. Tighten set screw. *(See Figure 22M.)*
3. Remove top metering drum hub for installation of metering drum drive shaft.
4. Insert drive shaft weldment up through bottom metering drum hub. Replace top metering drum hub on drive shaft. Secure top and bottom metering drum hubs with Q1 taper bushings. *(See Figure 22N and Figure 22O on Page 234.)*
5. Lower metering drum with drive shaft onto bearing support.

NOTE: Metering drum should have 1/4" to 1/2" clearance above hopper floor.

Level metering drum.

Bolt metering drum bearing to bearing support.

Use 3/8" x 1", grade 5 bolts and nuts.

6. Assemble four (4) gearbox torque arms and gearbox plate as shown in *Figure 22P and Figure 22Q on Page 235.)*

Bolt gearbox torque arms to inner hopper with existing bolts. Bolt gearbox plate with 1/2" x 1", grade 5 bolts and nuts.

7. Slide gearbox set collar (2-3/8") onto metering drum drive shaft. Do not tighten set screw yet. *(See Figure 22R on Page 235.)*



Figure 22L Cleaning metering drum drive shaft weldment.



Figure 22M Tightening set screw on metering drum bearing.

22. Metering System

Metering System (Continued)

8. Apply anti-seize to metering drum drive shaft as shown in [Figure 22S on Page 235](#) and [Figure 22T on Page 236](#).
9. If necessary, clean out bore of metering drum gearbox.
10. Bolt gearbox adapter plate to metering drum gearbox.
Use 1/2" x 1", grade 5 bolts and nuts.
11. Bolt gearbox adjustment plate to metering drum gearbox. ([See Figure 22U on Page 236](#).)
Use 1/2" x 1", grade 5 bolts and nuts.
12. Lower metering drum gearbox, and slide over metering drum drive shaft.
([See Figure 22V on Page 236](#) and [Figure 22W on Page 237](#).)

NOTE: Orient metering drum gearbox so motor will be as close as possible to where control box will be outside dryer.

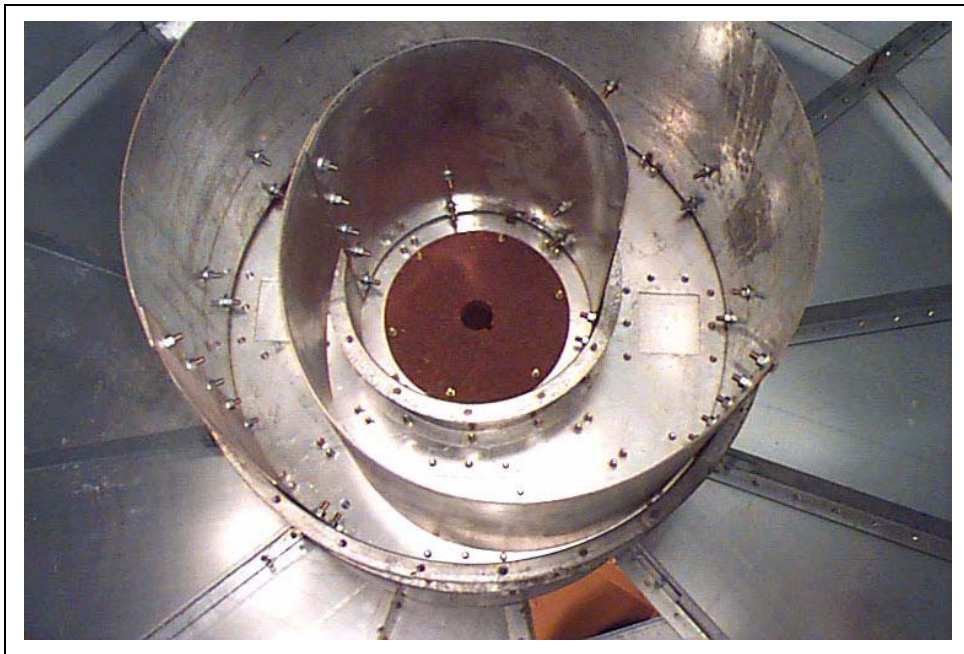

Figure 22N View from below metering drum.

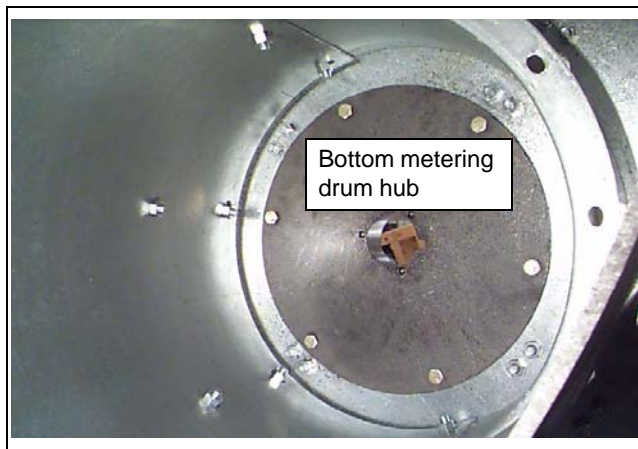

Figure 22O Close Up - Below metering drum.

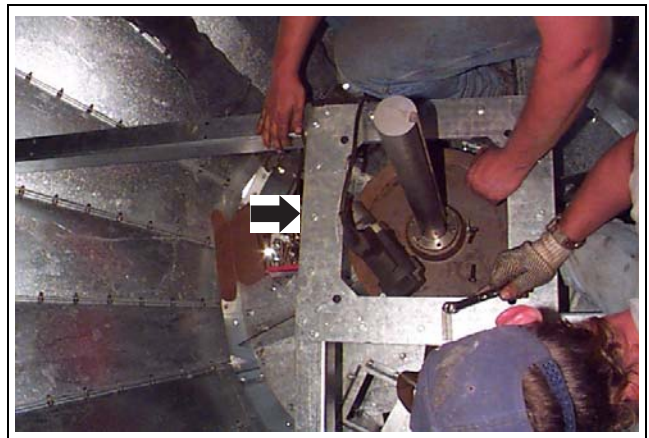

Figure 22P Assembling gearbox plate (arrow) to gearbox torque arms.

Metering System (Continued)

Align keyways on metering drum gearbox and metering drum drive shaft. Insert 5/8" x 5/8" x 5" key.

Bolt gearbox adjustment plate to gearbox torque arm assembly.

Use 1/2" x 1", grade 5 bolts and nuts.



Incorrect installation could stress gearbox and motor bearings, resulting in failure.

Bolt motor to gearbox. (See Figure 22Y on Page 237.)

Use 3/8" x 1", grade 5 bolts.



Figure 22Q Gearbox torque arm assembly installed to inside hopper wall.



Figure 22R Sliding gearbox set collar (2-3/8") onto metering drum drive shaft.



Figure 22S Applying anti-seize to metering drum drive shaft.

Metering System (Continued)

13. Slide gearbox set collar (2-3/8") up drive shaft until flush with gearbox. Tighten set screw.

Use 5/16" x 3/4" whiz lock bolts and nuts.

14. Fill gearbox lubricant reservoir with lubricant. *(See Figure 22Z and Figure 22AA on Page 237.)*

Gearbox lubrication: Gearbox requires amoco perma gear 220 (or equivalent lubricant). Remove gearbox lubricant reservoir plug and fill reservoir 1" to 1-1/2" from top. Remove fill hose.

NOTE: *This is a slow process.*

IMPORTANT: *It is very important that no air is left in reservoir. Remove fitting from top of gearbox. Add a few more ounces of lubricant to gearbox lubricant reservoir, until lubricant reaches fitting hole.*

Replace plug and check for leaks.



Figure 22T *Applying anti-seize to top of metering drum drive shaft before installing gearbox.*

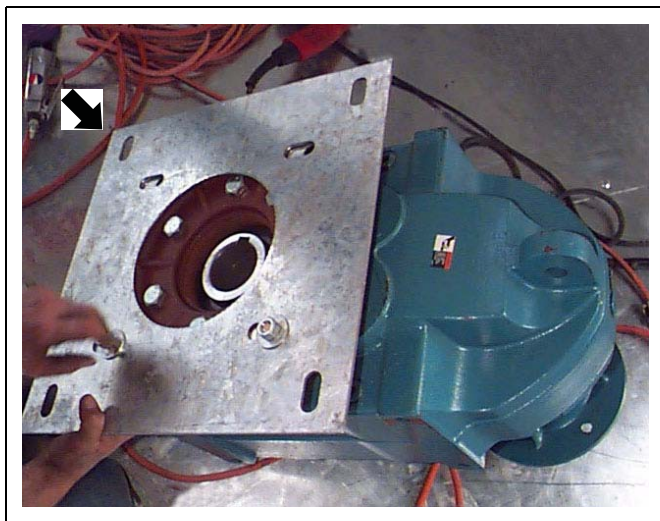

Figure 22U *Bolting gear adjustment plate (arrow) to metering drum gearbox.*

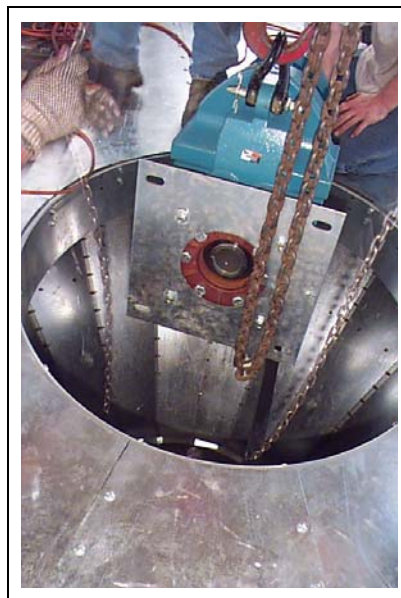

Figure 22V *Lowering metering drum gearbox over metering drum.*

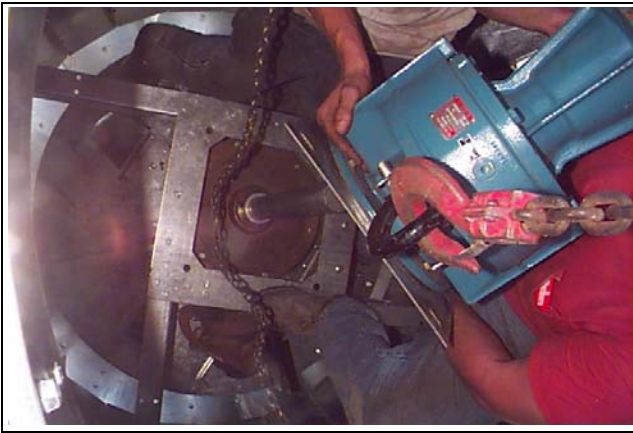

Figure 22W Sliding metering drum gearbox over metering drum drive shaft.

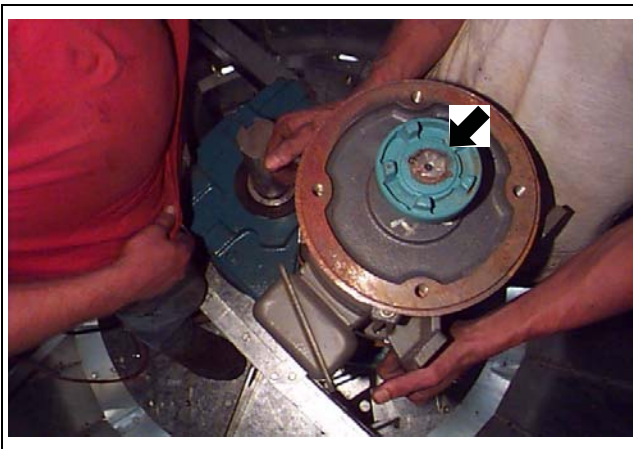

Figure 22X Install motor shaft coupling body (arrow) to metering drum motor, then insert motor shaft coupling insert (not shown).



Figure 22Y Bolting motor to gearbox (top mount).
NOTE: Motor to gearbox configuration can vary.



Figure 22Z Filling gearbox with amoco perma gear 220 (or equivalent lubricant).

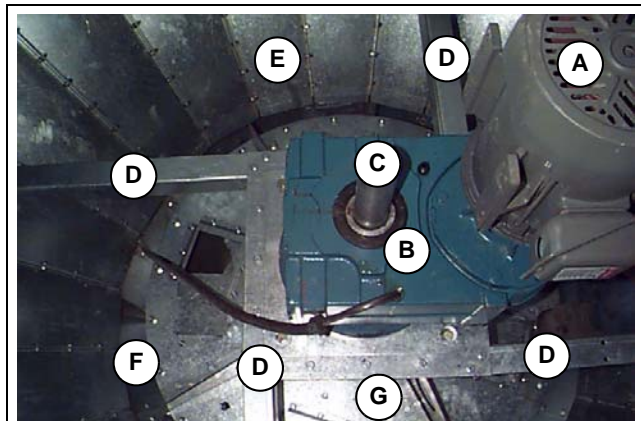

- A. Metering Drum Motor
- B. Metering Drum Gearbox
- C. Metering Drum Drive Shaft
- D. Gearbox Torque Arm Assembly (with 4 arms)
- E. Inside Hopper Wall
- F. Metering Drum Baffles
- G. Metering Drum

Figure 22AA Adding lubricant to gearbox lubricant reservoir.



Important Safety Precautions:

**Dryer has sharp edges. These sharp edges may cause serious injury.
Use appropriate personal protective equipment. Use proper lifting techniques.**

See [Orientation Section on Page 19](#) for dryer dimensions, components, wall sheet guidelines, etc.
See [Appendix A on Page 435](#) for tools and equipment, [Appendix B on Page 437](#) for hardware, etc.

Fuel Piping (Main) (Natural Gas or Liquid Propane)

Piping through Housing

Attach 12" nipple and union to burner manifold. Run first 3" pipe section vertically down through reducer housing and out pre-cut hole in center of fan housing splice. Secure with pipe riser clamp.

Piping in Cool Section

Continue 3" fuel piping vertically into cool section of dryer to just below bottom of fans. Add 90° elbow and continue piping horizontally through dryer window. Secure fuel piping with clevis hanger and threaded rod as needed.

Piping through Window

Run 3" fuel piping out dryer window and add elbow.

Piping Outside Dryer

Continue 3" fuel piping from dryer window vertically down, parallel to side of dryer. Secure to compression angle with U-bolt. Add union and 12" nipple before attaching fuel train.

NOTE: See [Page 244](#) for fuel train.

Fuel piping runs from bottom of burner to fuel train on foundation.

(Main) Fuel piping and pilot fuel piping usually run parallel.

Electricians will install pilot fuel piping. Pilot fuel piping (3/8" copper tubing) runs from pilot section on burner to pilot section on fuel train.



Figure 23A 3" Fuel Piping

Fittings for Fuel Piping



Figure 23B *Elbow, 3" 90°*

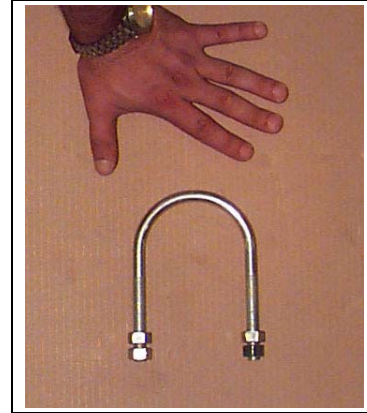

Figure 23E *3" U-bolt*



Figure 23C *3" Union, (3 parts)*

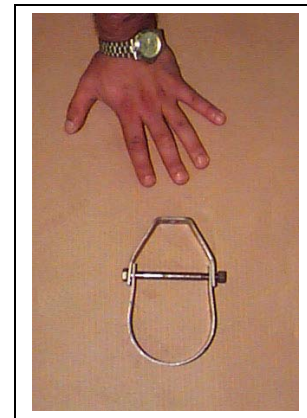

Figure 23F *Hanger, 3" Clevis*

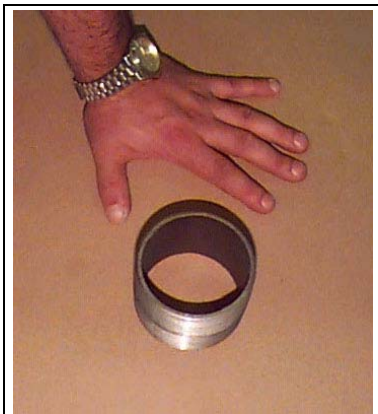

Figure 23D *Nipple 3" Close*

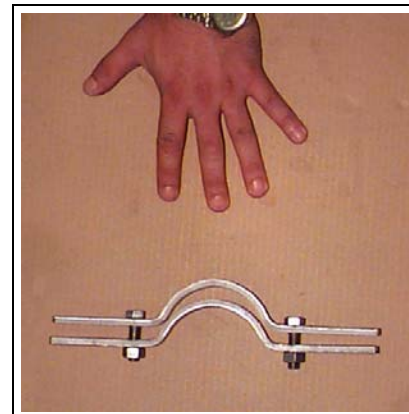

Figure 23G *3" Pipe Riser Clamp*



Figure 23H *Threaded Rod (Use with 3" clevis hanger.)*

23. Fuel Piping

Fuel Pipe Lengths*

Dryer Model	Pipe Diameter	Outside	Entry	Inside
2500	3"	140"	110"	167"
3000	3"	180"	110"	167"
3500	3"	180"	110"	185"
4000	3"	125" and 94"	110"	185"

*All piping and fittings are schedule 40 black.

Fuel Piping Guidelines

Fuel piping can be installed in sections as dryer is erected, or after dryer is complete. Usually top two (2) sections of fuel piping are installed after fans are installed.

Fuel piping enters dryer through a dryer window. Plan fuel piping so it will terminate as near as possible to where fuel train will be on foundation.

Seal all threaded pipe connections with heavy duty pipe sealing compound. Fuel piping must be airtight and satisfy any hazard requirement for the site.

Check all fuel piping is level or plumb.

Check all fuel piping is secured tightly to dryer.



Figure 23I Seal all threaded pipe connections with heavy duty pipe sealing compound.

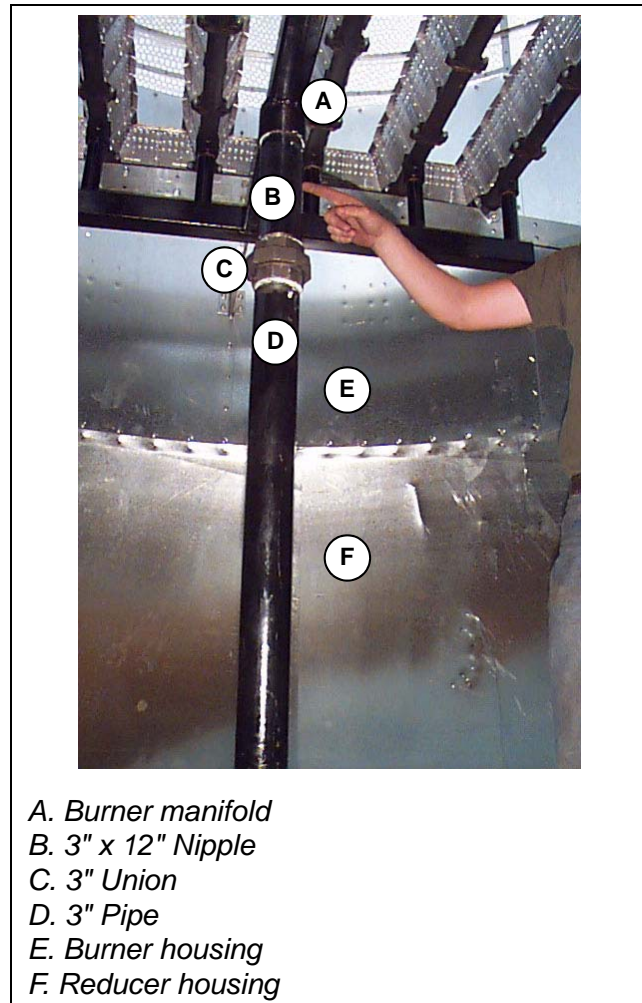

Figure 23J Fuel piping installed to burner manifold.

Fuel Piping Guidelines (Continued)



Figure 23K Installed fuel pipe exits heat section through pre-cut hole in center of fan housing splice (arrow).



Figure 23L Close Up - Installed fuel piping exits heat section through pre-cut hole in center of fan housing splice. **NOTE:** 3" Pipe riser clamp.

Fuel Piping Guidelines (Continued)

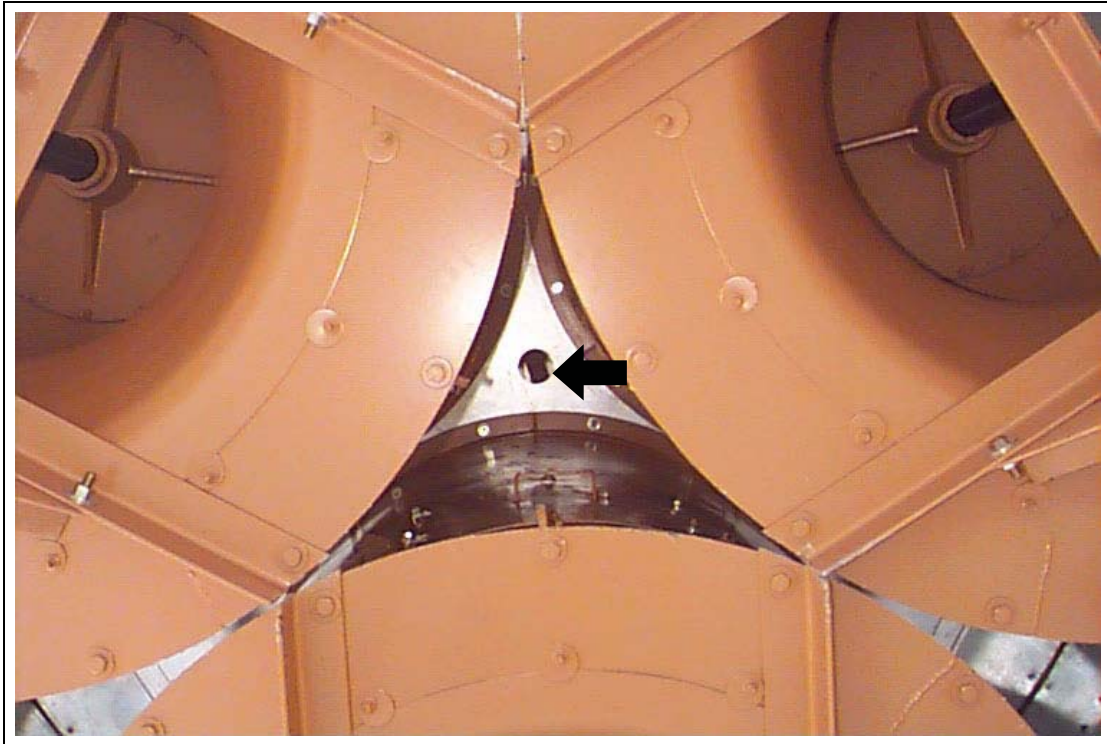

Figure 23M Fuel pipe enters cool section through pre-cut hole in center of fan housing splice (arrow).

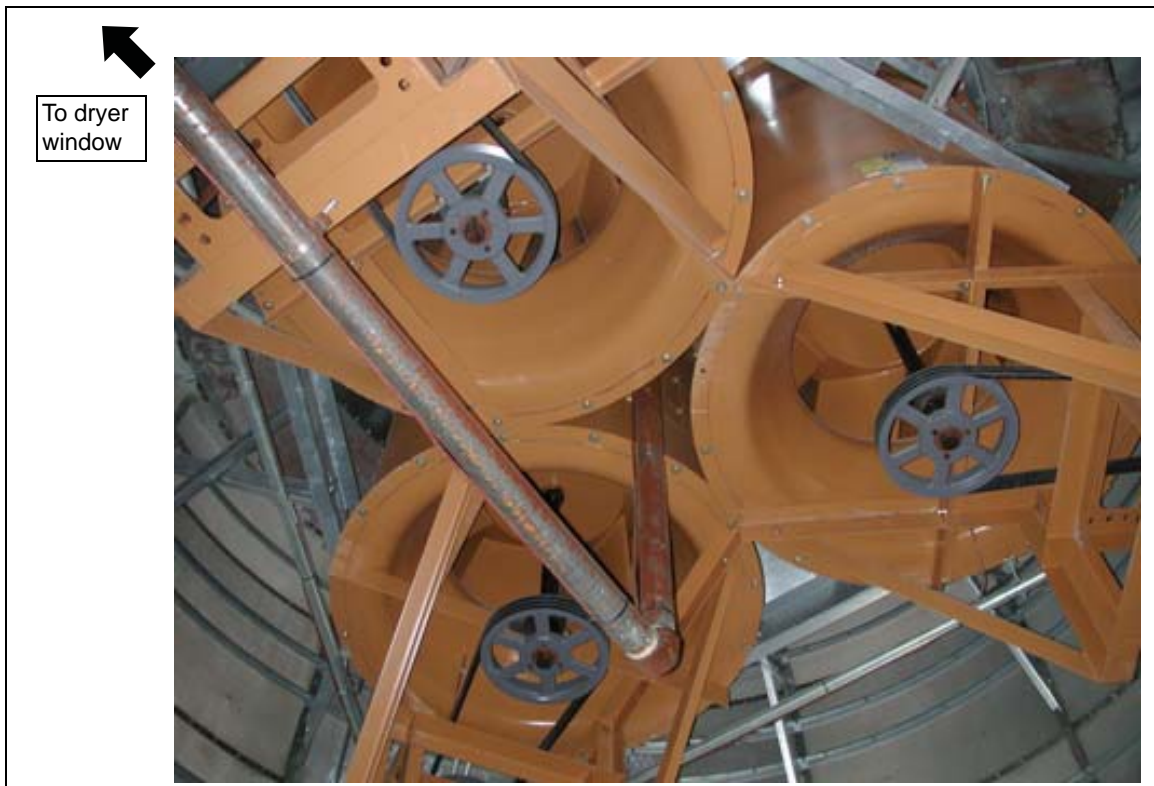

Figure 23N Just below fans, installed fuel piping turns 90°, and exits cool section through dryer window.

Fuel Piping Guidelines (Continued)



Figure 23O

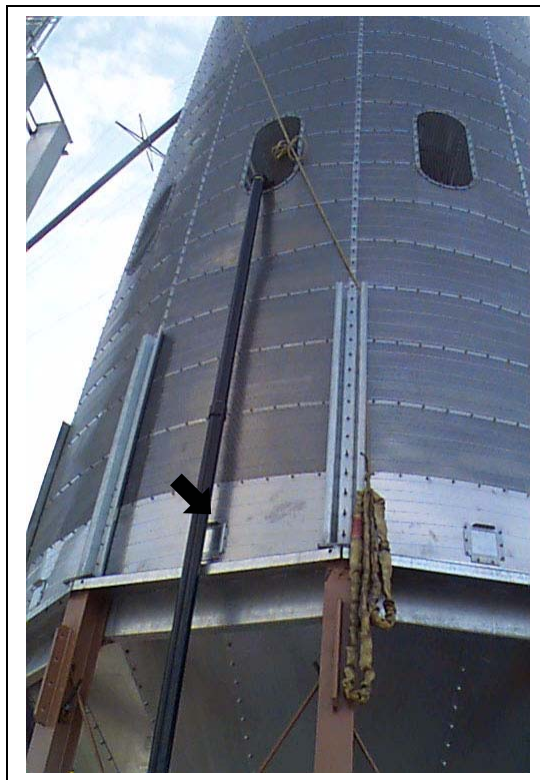

Figure 23P *Secure piping to compression angle with U-bolt (arrow).*

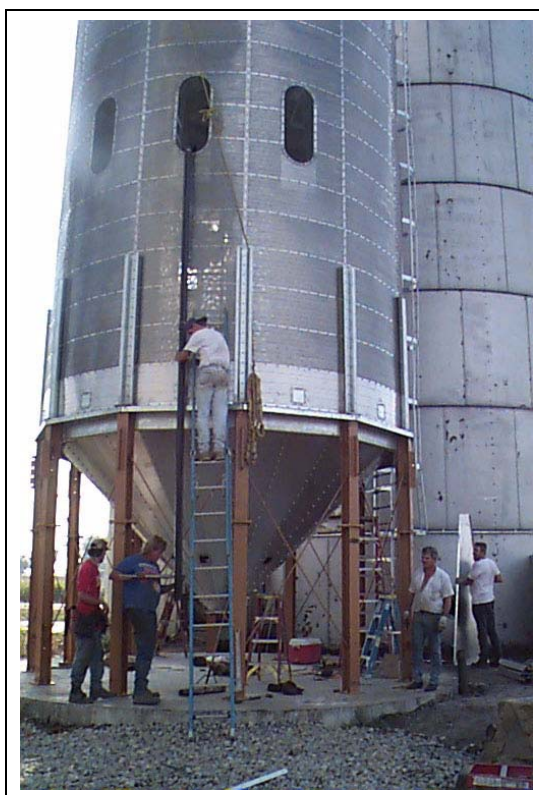

Figure 23Q

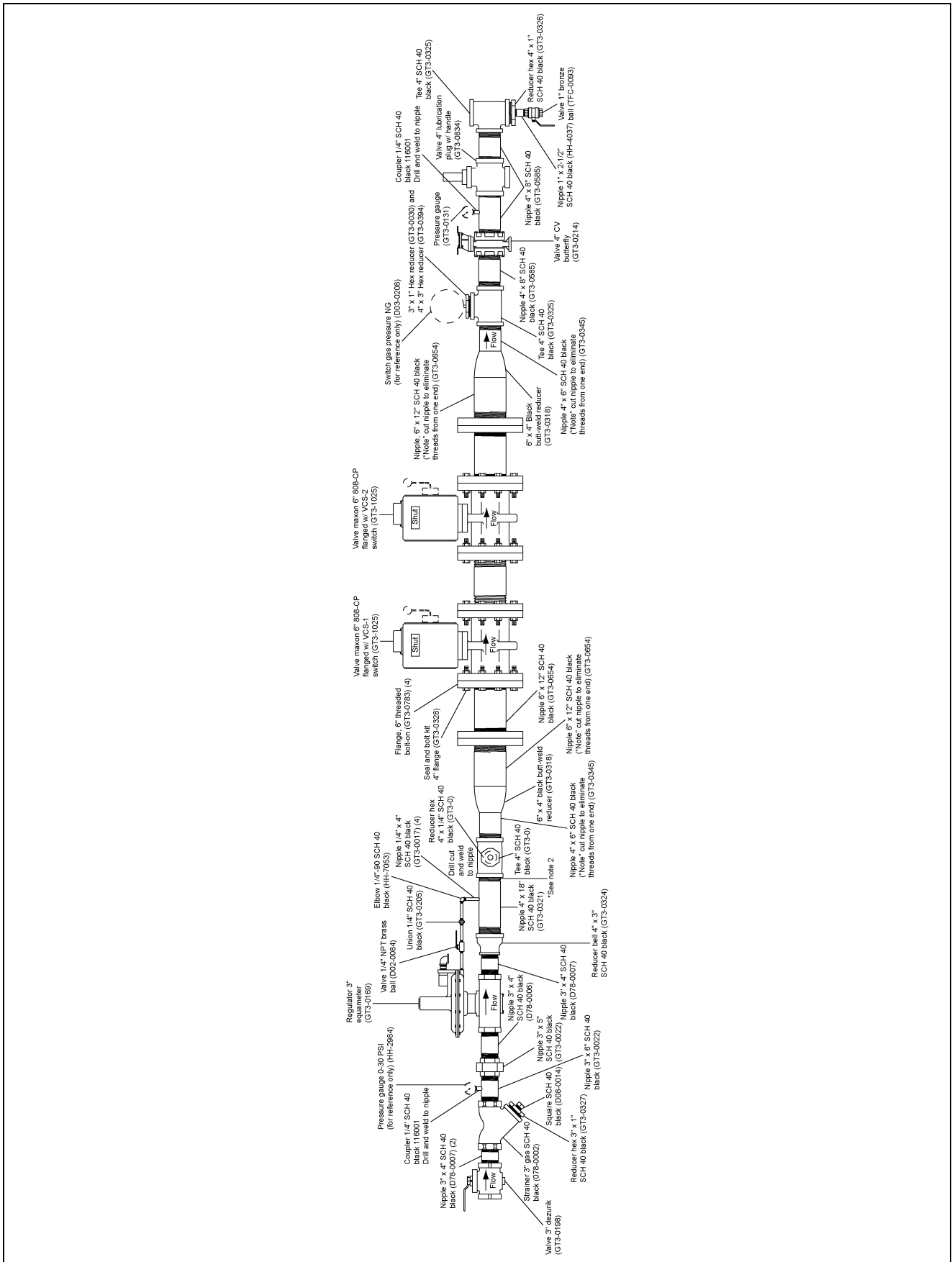

Figure 24A



Important Safety Precautions:
 Dryer has sharp edges. These sharp edges may cause serious injury. Use appropriate personal protective equipment. Use proper lifting techniques.

See [Orientation Section on Page 19](#) for dryer dimensions, components, wall sheet guidelines, etc.
 See [Appendix A on Page 435](#) for tools and equipment, [Appendix B on Page 437](#) for hardware, etc.

Natural Gas or Liquid Propane

NOTE: Electrical wiring and pilot fuel line installation are done by electricians.

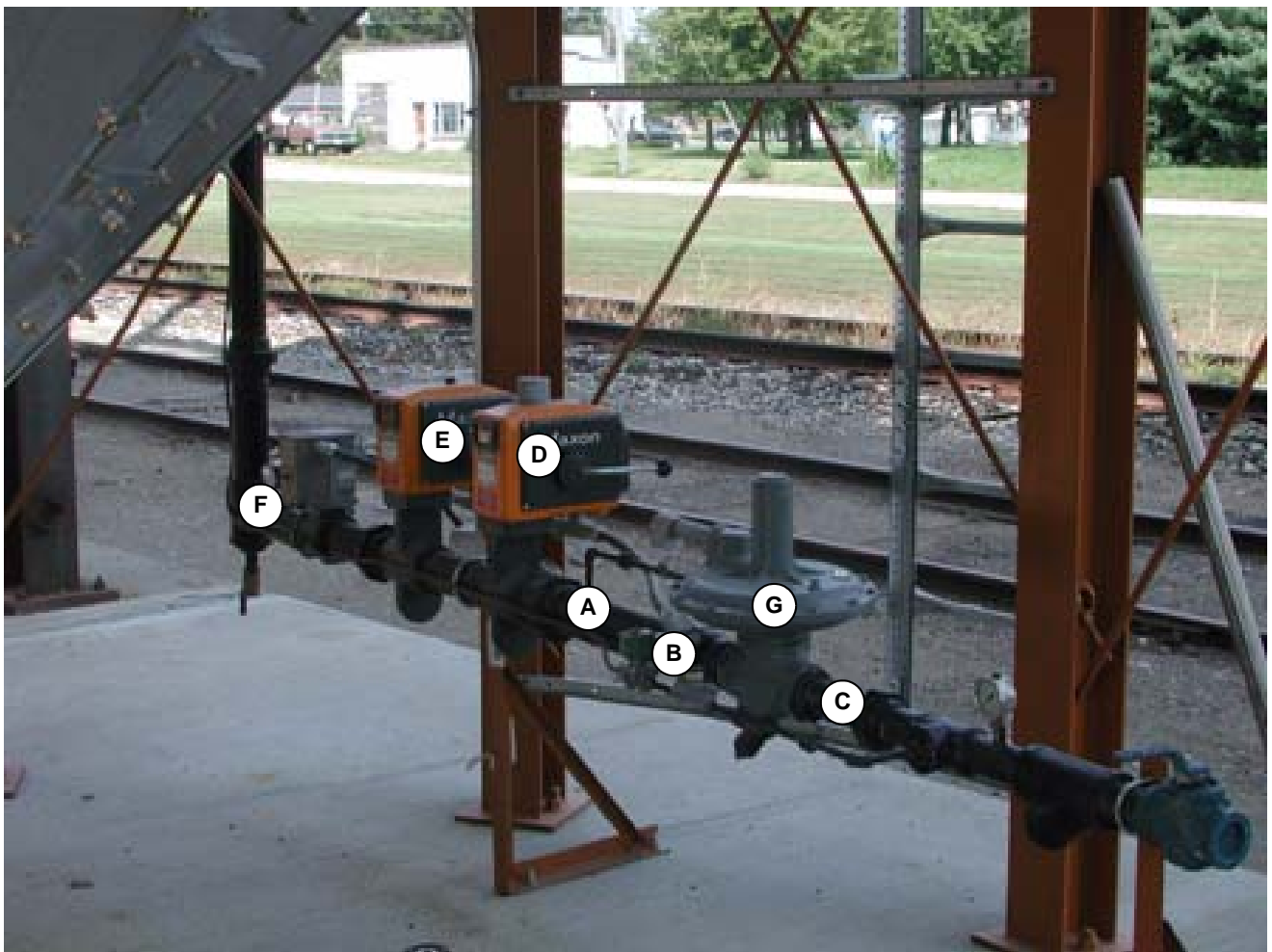

- A. Pilot fuel line
- B. Pilot regulator on pilot fuel train
- C. Pilot solenoid on pilot fuel train
- D. Maxon fuel shut off valve - primary
- E. Maxon fuel shut off valve - secondary
- F. Modutrol motor
- G. Main fuel regulator

Figure 24B Example - Fuel train installed.

Components (shipped Pre-assembled)

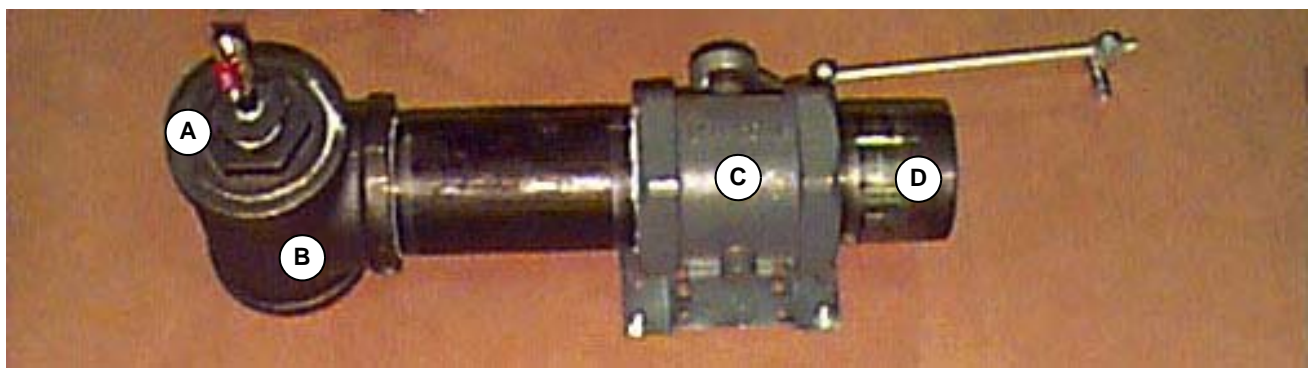

- A. 1/4" Shut off valve
- B. 3" Tee
- C. 3" Modutrol valve
- D. Linkage

Figure 24C 3" Modulator Section

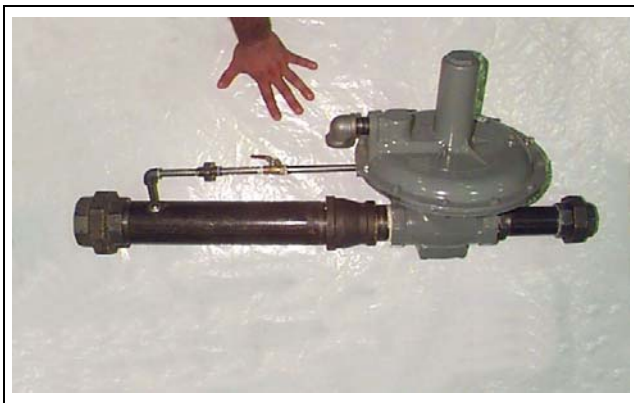

Figure 24D 3" Regulator Section

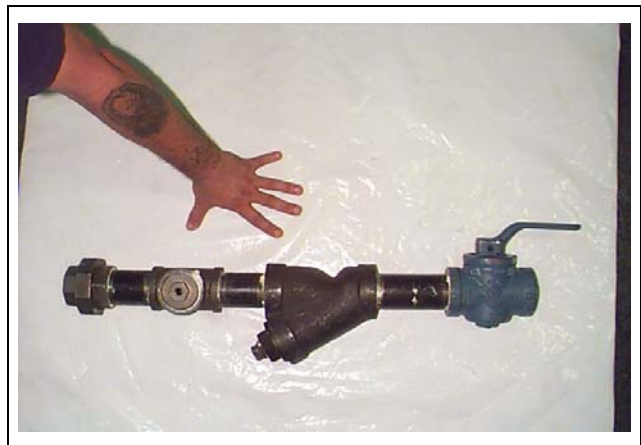

Figure 24F 2" Manual Shut Off Section



Figure 24E 3" Maxon Shut Off Valve Section

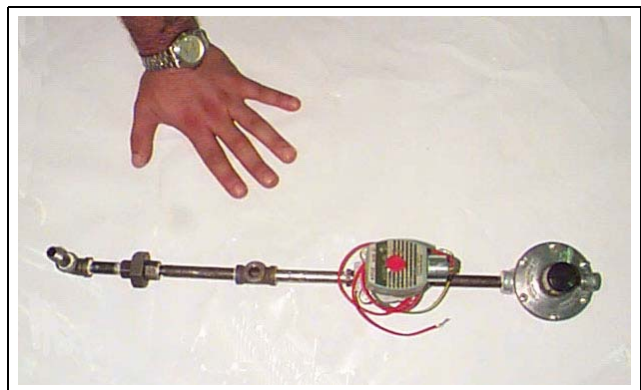

Figure 24G 1/4" Pilot Section

Demonstration Close Ups

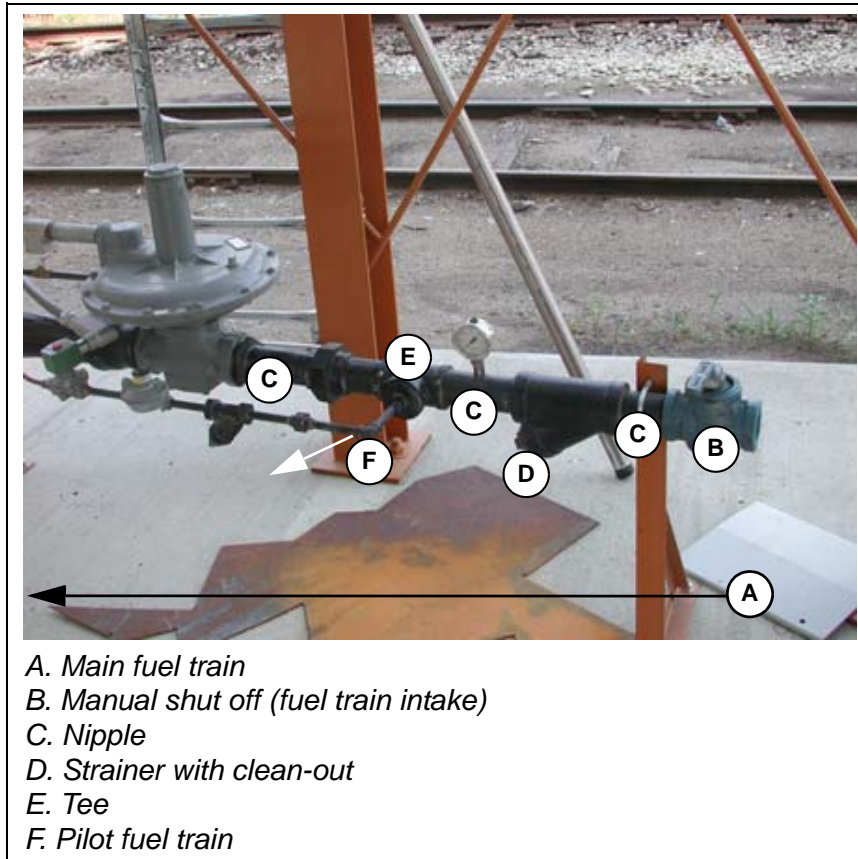

Figure 24H

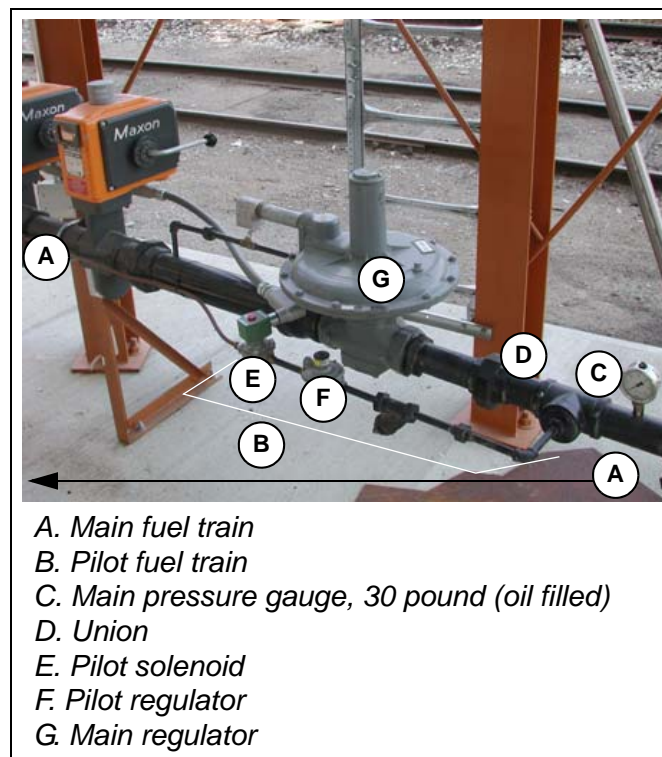

Figure 24I

Demonstration Close Ups (Continued)

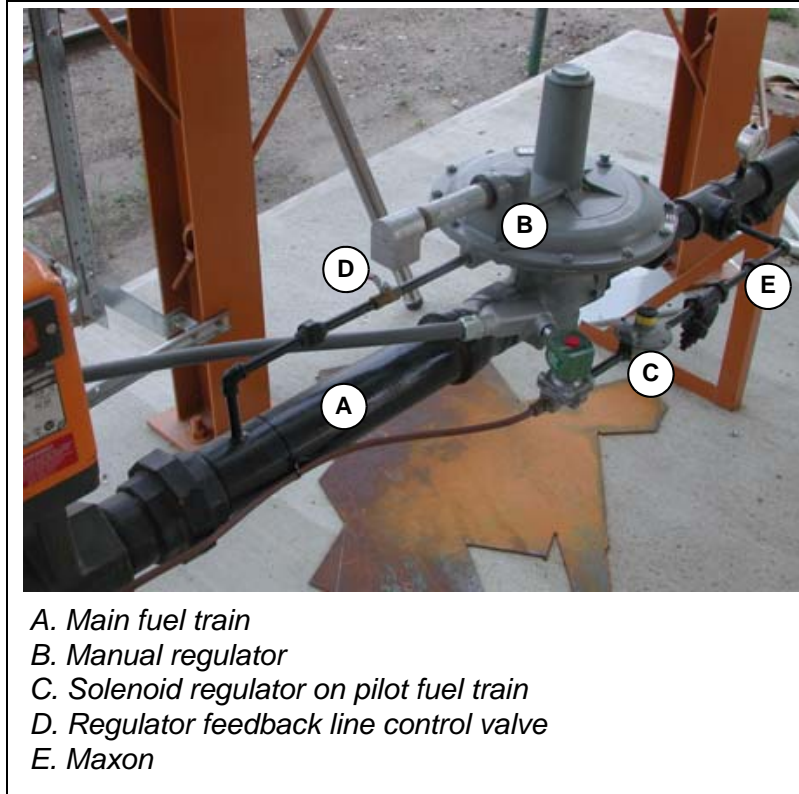

Figure 24J

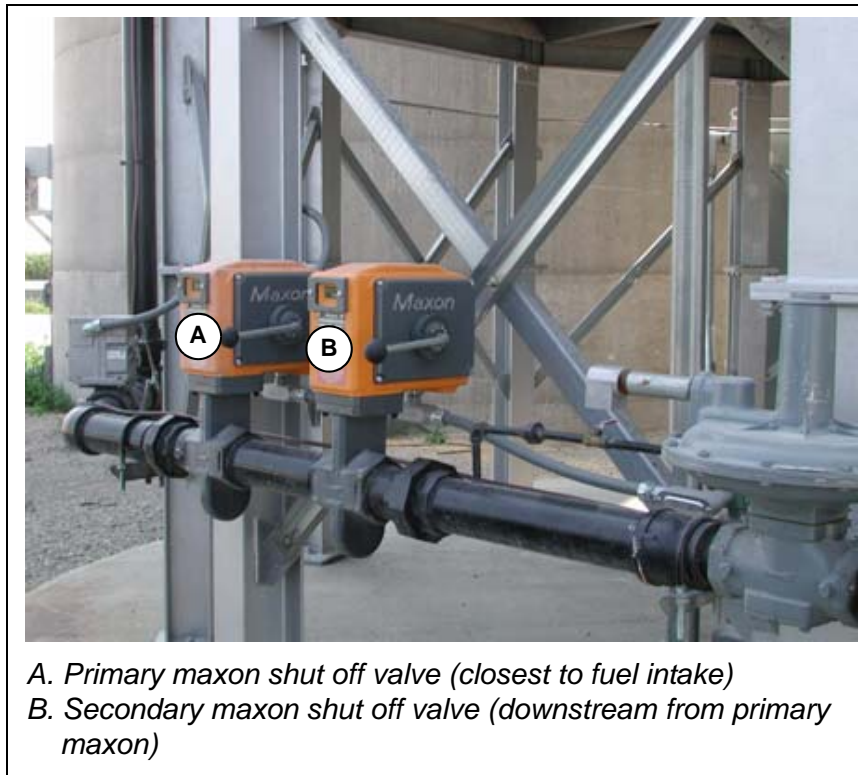
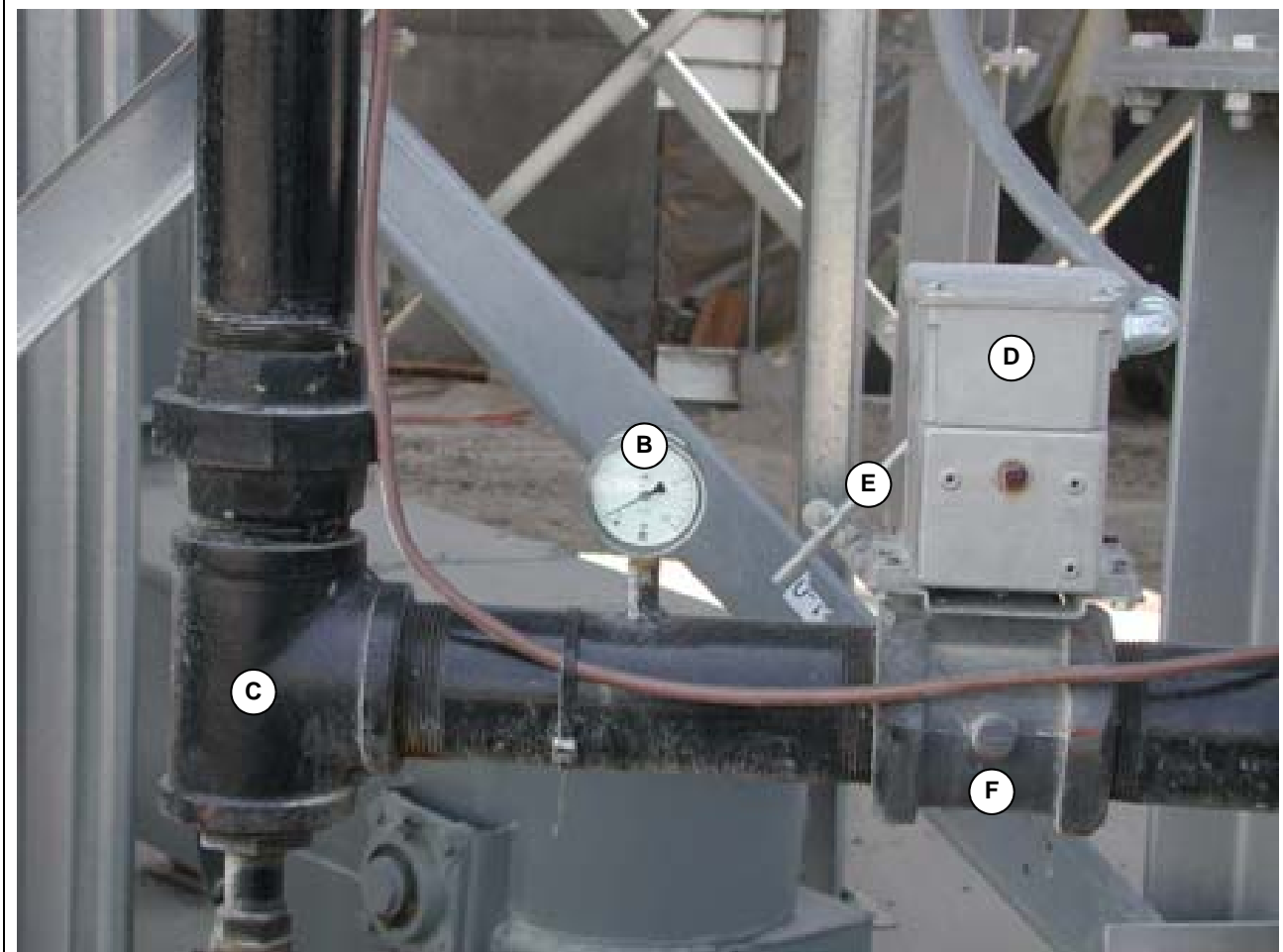

Figure 24K

Demonstration Close Ups (Continued)



- A. Secondary maxon shut off valve (N/S)
- B. Ounce gauge
- C. Tee (up to dryer) (down to drain valve)
- D. Modutrol motor
- E. Flow control valve linkage
- F. Maxon flow control (butterfly) valve

Figure 24L

Installation Guidelines

NOTE: Fuel train components will be wired to electrical control system (by electricians), so locate fuel train as close as possible to electrical control system.

Mount fuel train on two(2) or three(3) stands as required. Mark, cut, and drill to adapt fuel train stands to meet specific site requirements.

Check during installation to keep fuel train level.

As required, break apart fuel train components, and install as shown in [Figure 24A on Page 244](#), fuel train.

IMPORTANT: Seal all threaded pipe connections with heavy duty pipe sealing compound.

Check arrows (or other fuel intake direction indicators) on all fuel train components. Be sure all arrows point in direction of fuel flow.

IMPORTANT: Until fuel train installation on stands is complete, support components securely at all times.



Figure 24M Seal all threaded pipe connections with heavy duty pipe sealing compound.



Figure 24N As required, break apart fuel train components, and install as shown in ([see Figure 24A on Page 244](#)), fuel train.



Figure 24O

IMPORTANT: Be careful not to cross thread pipe to union.



Figure 24P Tightening union to fuel pipe.



Figure 24R Connecting modutrol section to fuel pipe.



Figure 24Q Attaching 12" nipple to modutrol section.



Figure 24S Maxon Section.



Figure 24T Close Up - Maxon. **NOTE:** Fuel flow indicators on all components.

24. Fuel Train

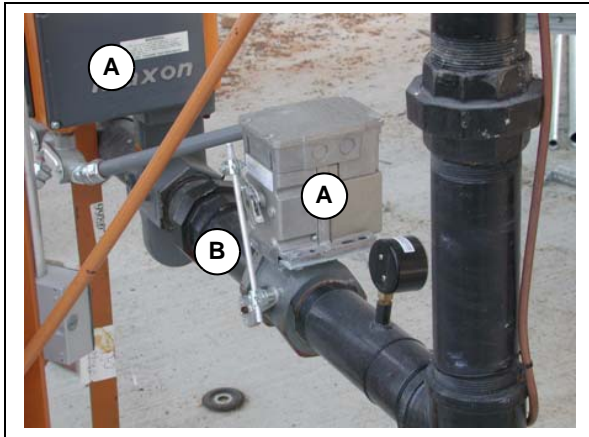

Figure 24U Maxons (A) and modutrol mounting bracket (B) installed. Support fuel train at all times.

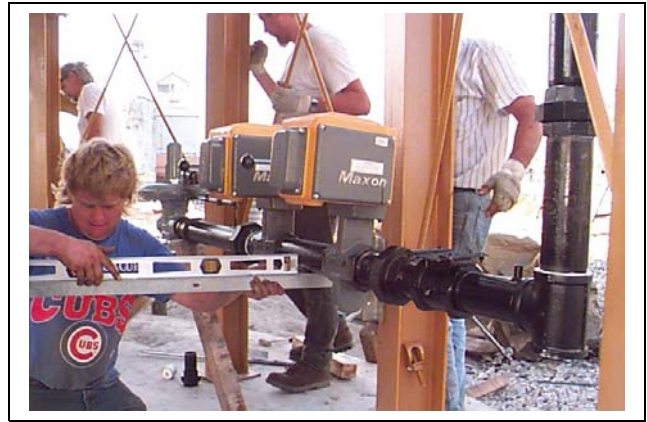

Figure 24X Adapt fuel train stands to meet site requirements.



Figure 24V Installing regulator section.



Figure 24Y Close Up - Bolting fuel train stand.



Figure 24W Checking fuel train is level, then measuring for fuel train stands.



Figure 24Z Securing fuel train to fuel train stand with 3" U-bolt.



Figure 24AA *Installing shut off section.*



Figure 24AB *Second fuel train stand installed.*



Figure 24AC *Fuel train installed. (Typical)*

25. Electrical Control System



Important Safety Precautions:

Dryer has sharp edges. These sharp edges may cause serious injury. Use appropriate personal protective equipment. Use proper lifting techniques.

See [Appendix A on Page 435](#) for recommended tools and equipment list, [Appendix B on Page 437](#) for hardware, etc.

The **electrical control system** consists of a main **power box** and a **control box**. The control box is usually attached and wired to the power box at the factory. (See [Figure 25A.](#))

See “electrical installation manual” for steps to install electrical control system.

Until electrical control system is installed, place it on dryer foundation and secure it to dryer leg.

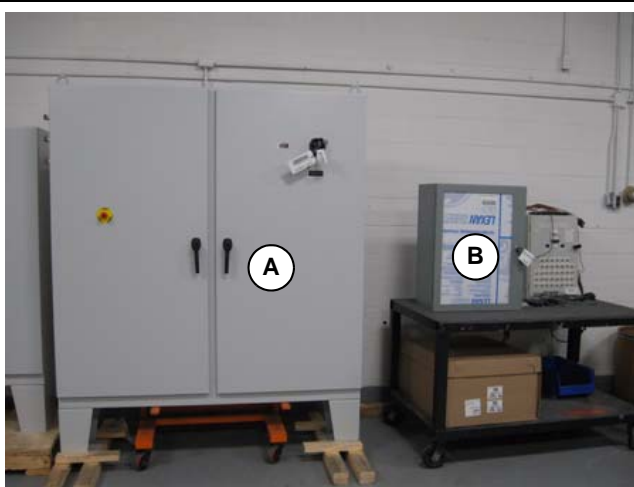

- A. Power box.
- B. Control box with electronic monitoring control system.

Figure 25A



Figure 25B *Electrical Control System*

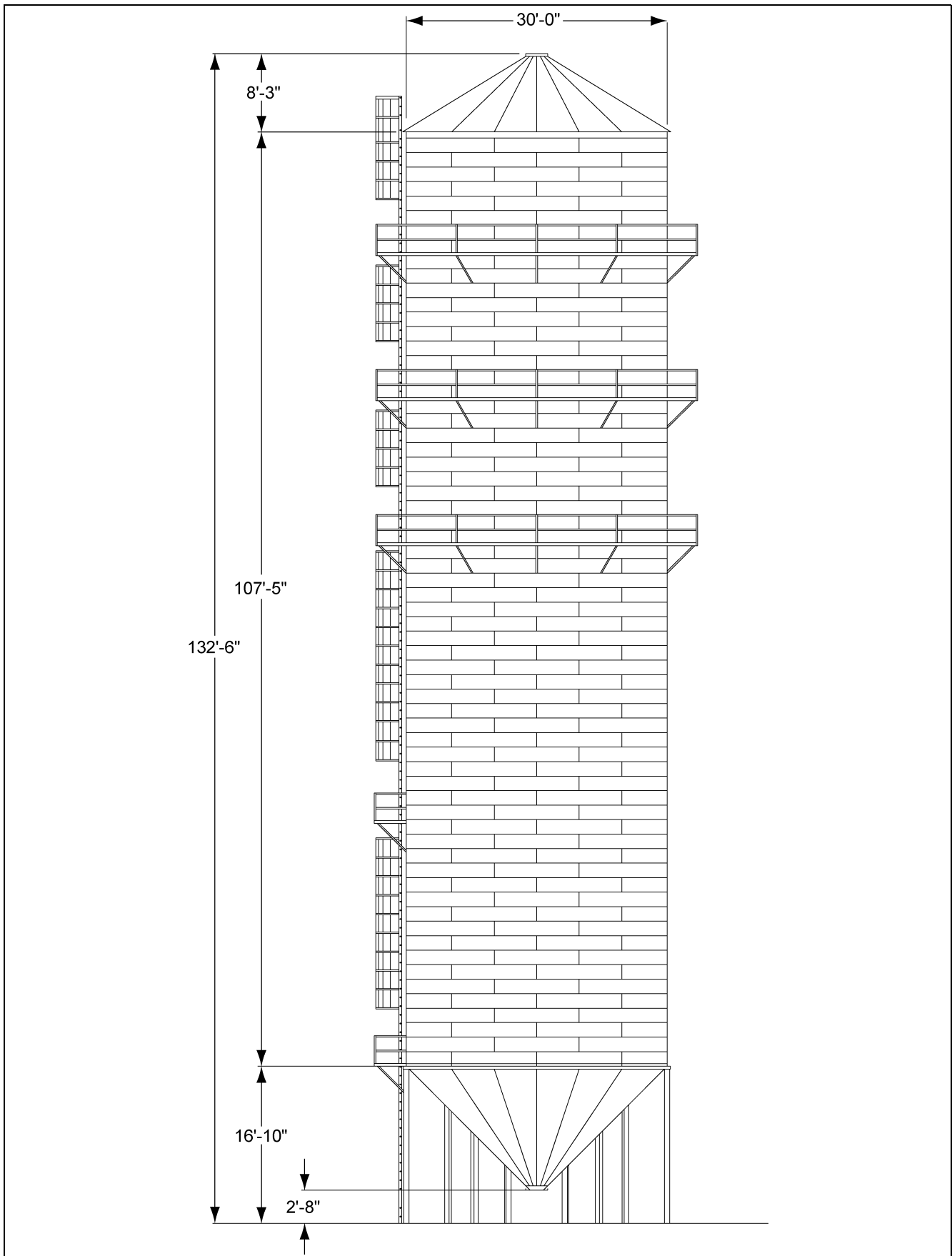

Figure 26A GSI Tower Dryer Model 10000

26. All Tower Dryer Models Drawings

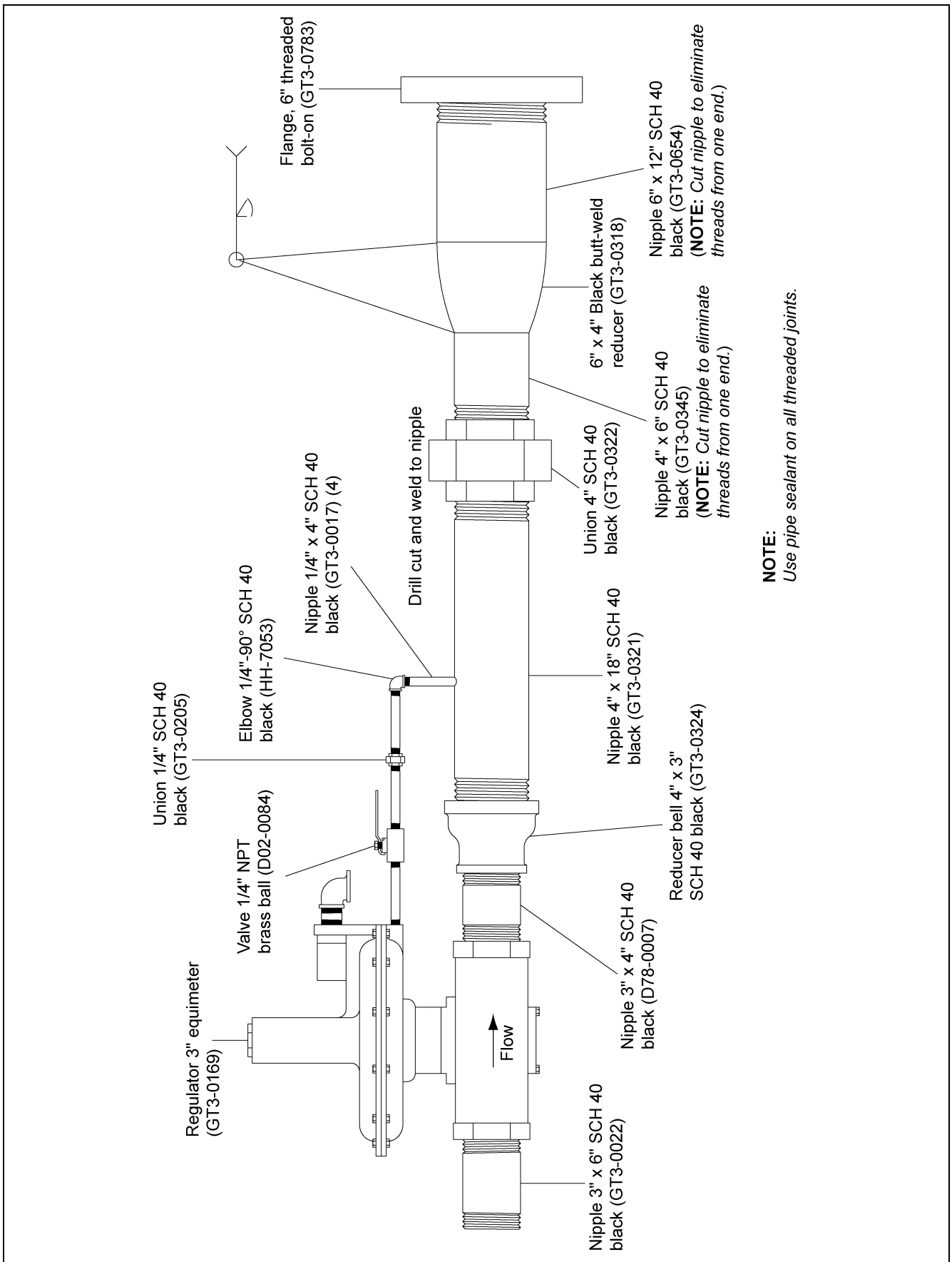

Figure 26B 6" Regulator Section - Domestic

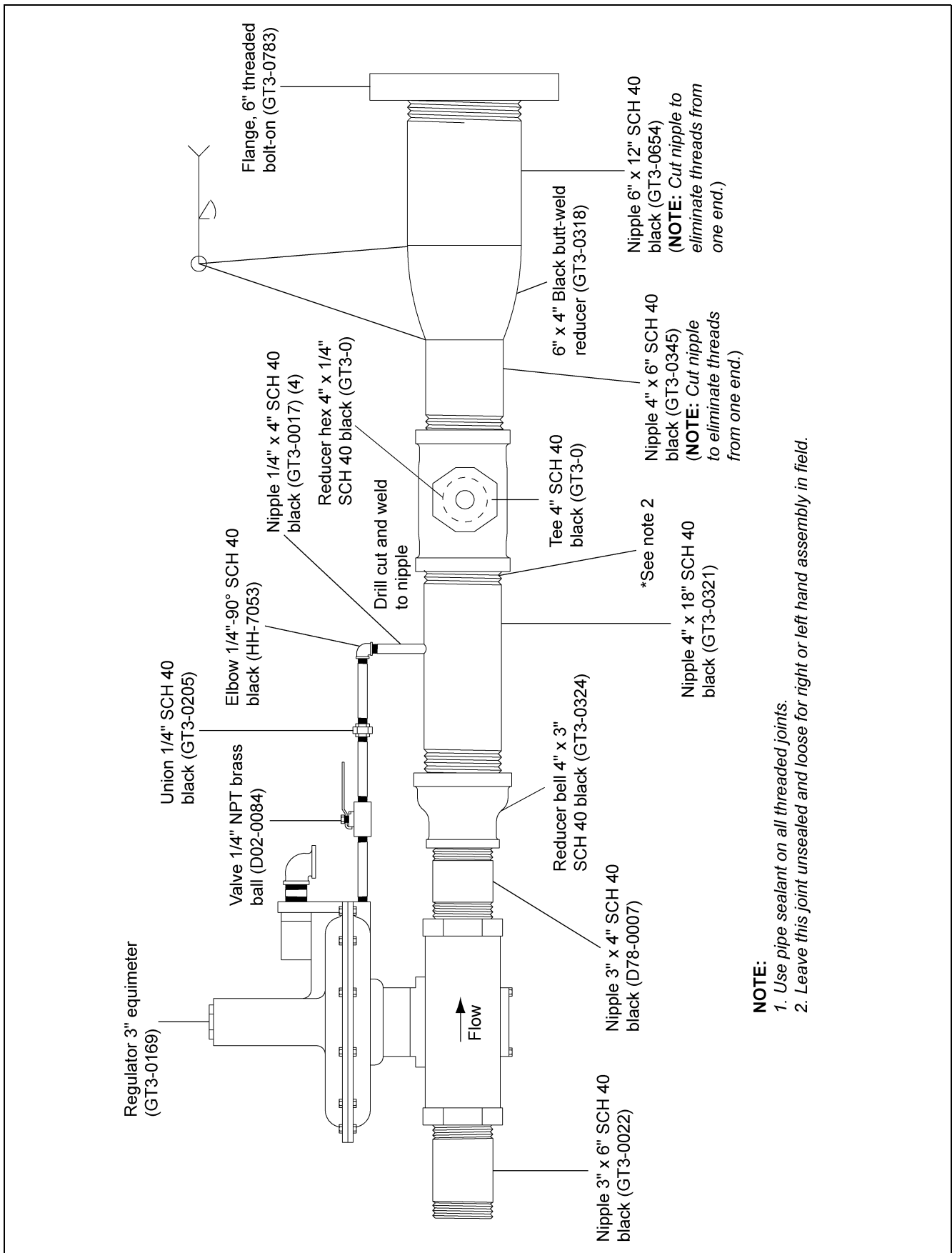

Figure 26C 6" Regulator Section - Canadian

26. All Tower Dryer Models Drawings

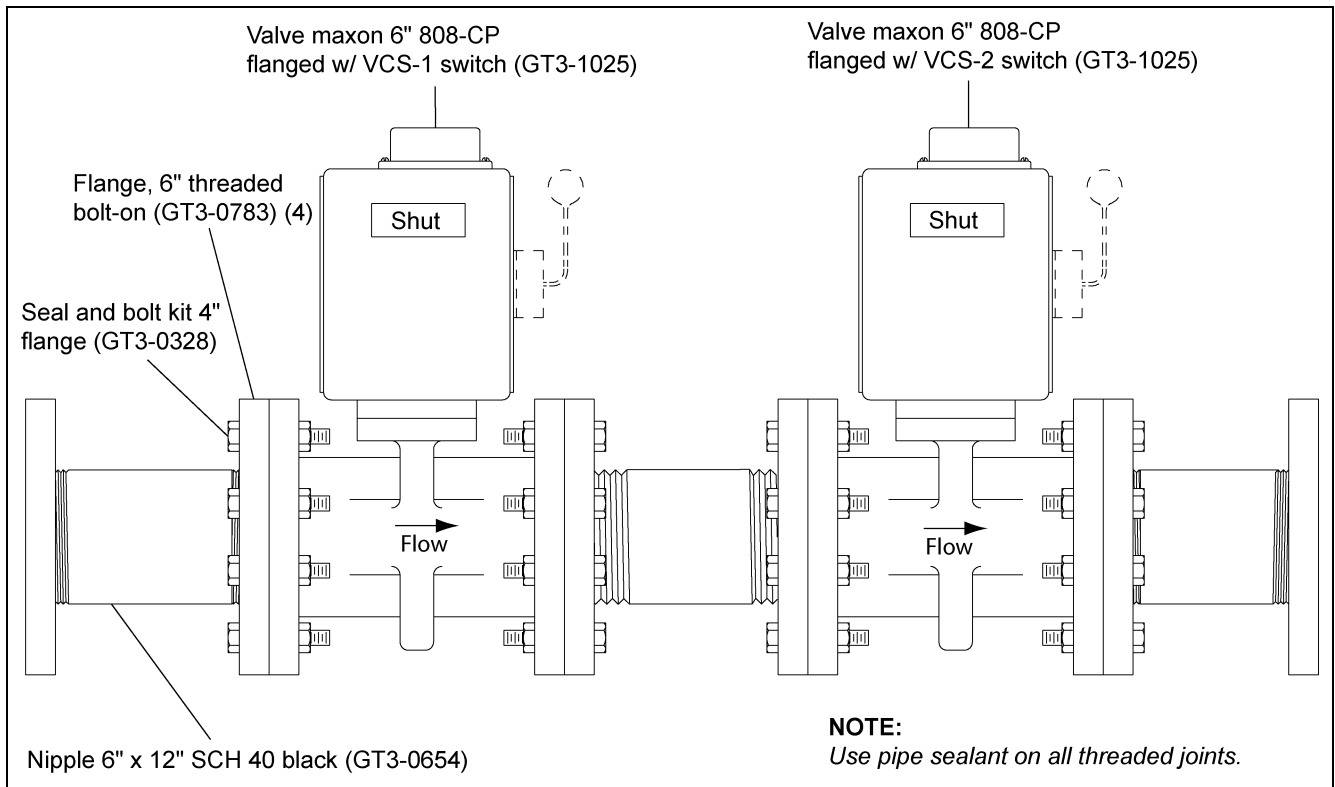

Figure 26D 6" Maxon Section - Domestic

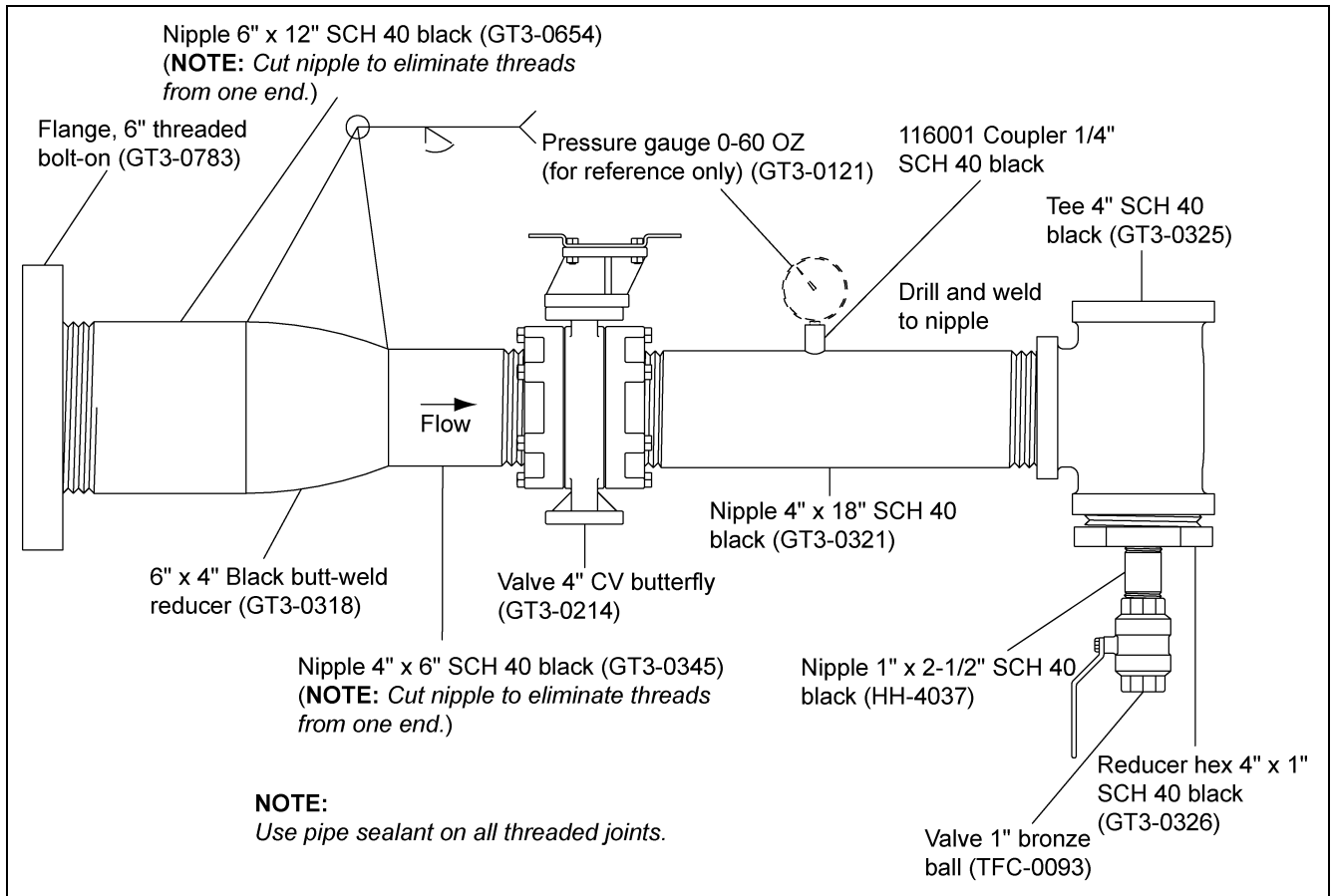

Figure 26E 6" Modulator Section - Domestic

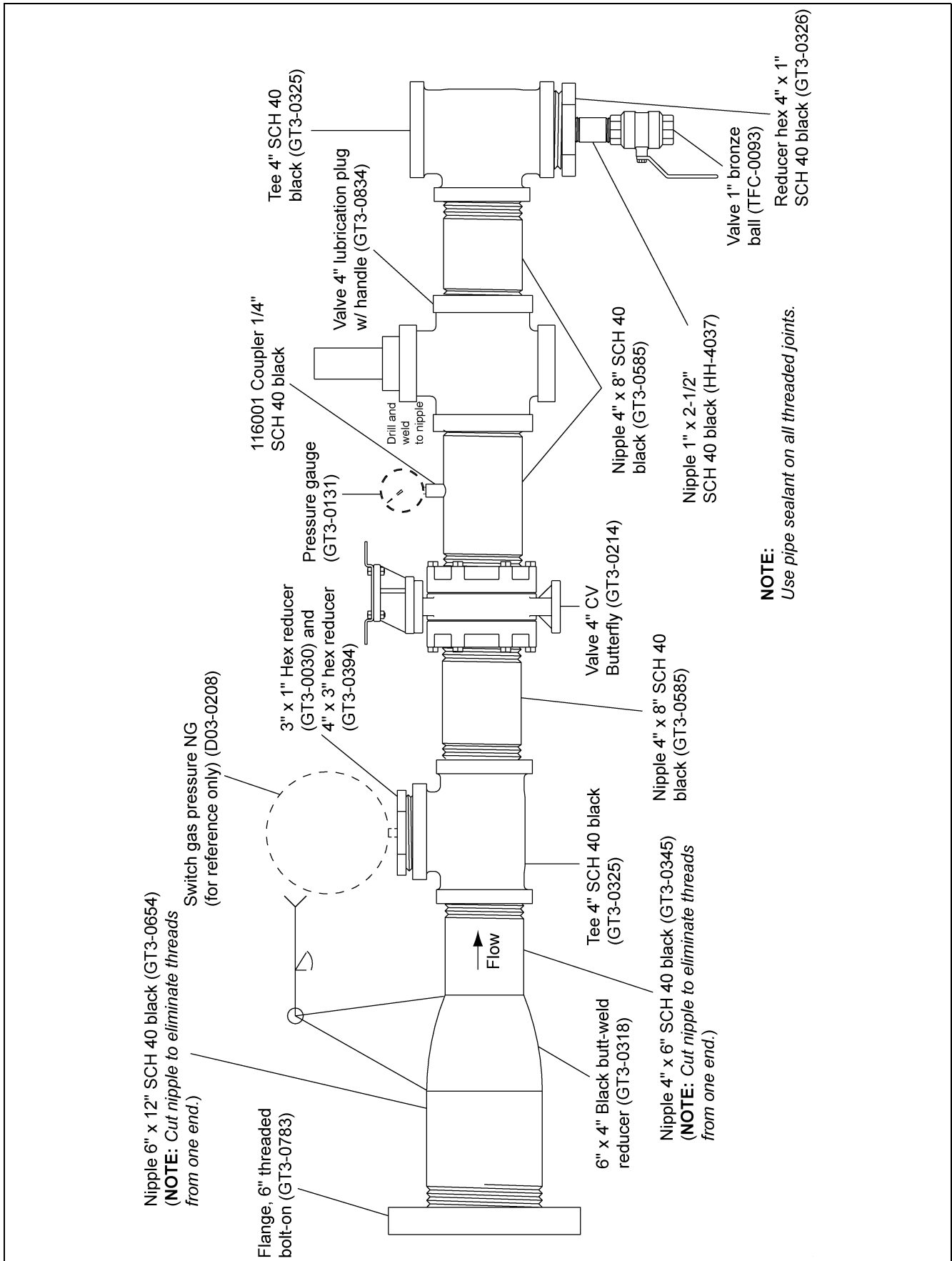

Figure 26F 6" Modulator Section - Canadian

26. All Tower Dryer Models Drawings

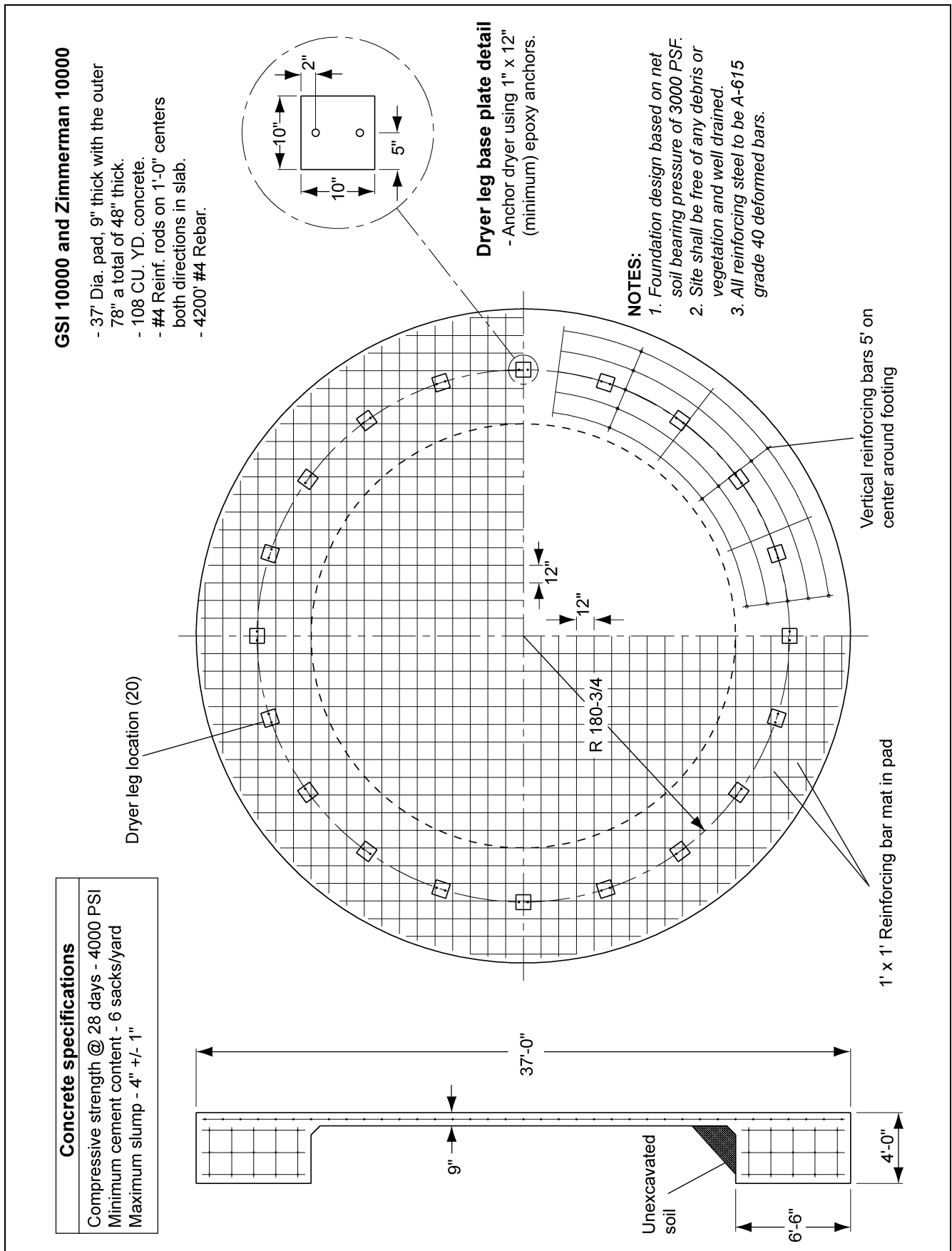

Figure 26G Foundation Plan - 30' Dryer

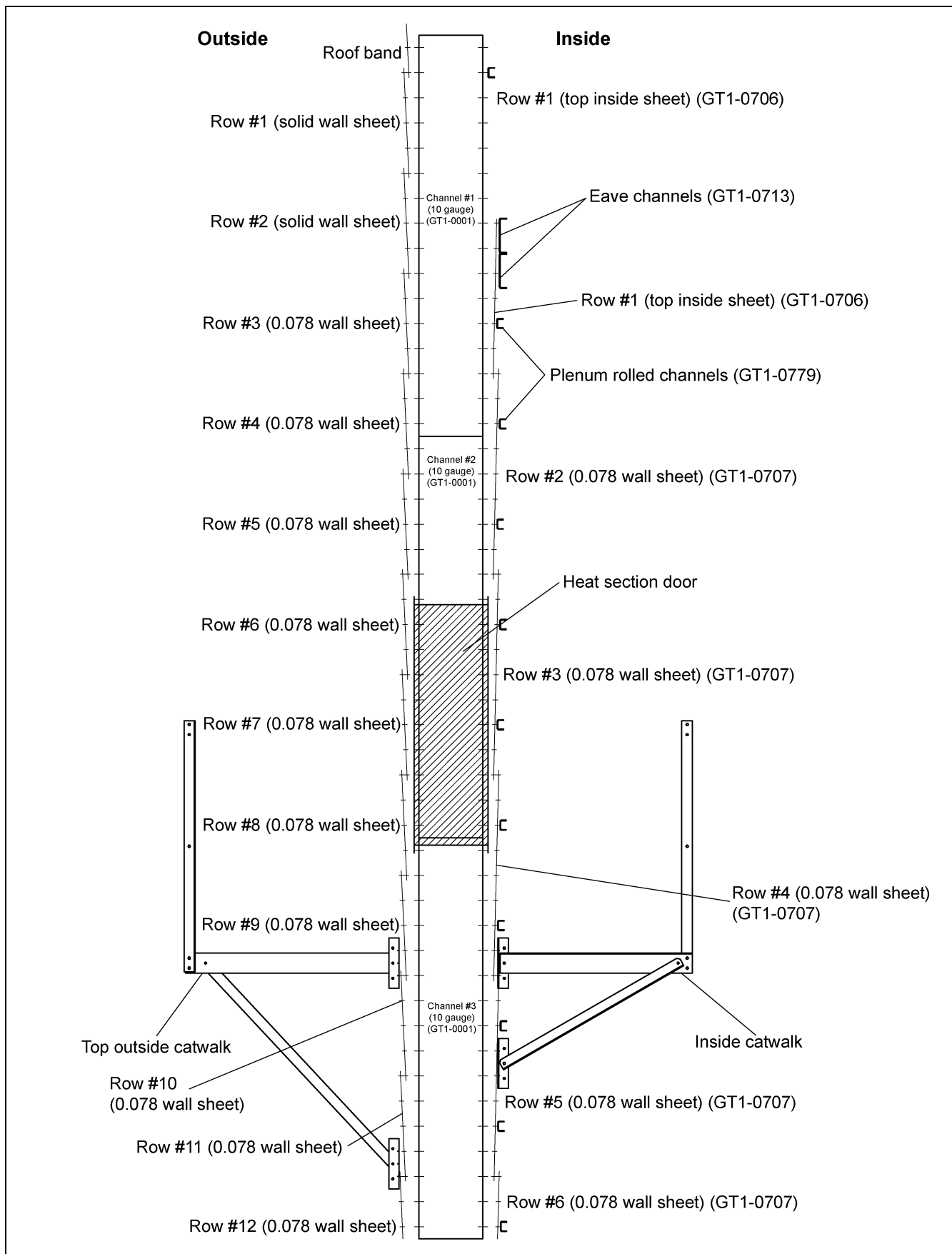

Figure 26H Clip Placement Z-10K Channels 1 to 3

26. All Tower Dryer Models Drawings

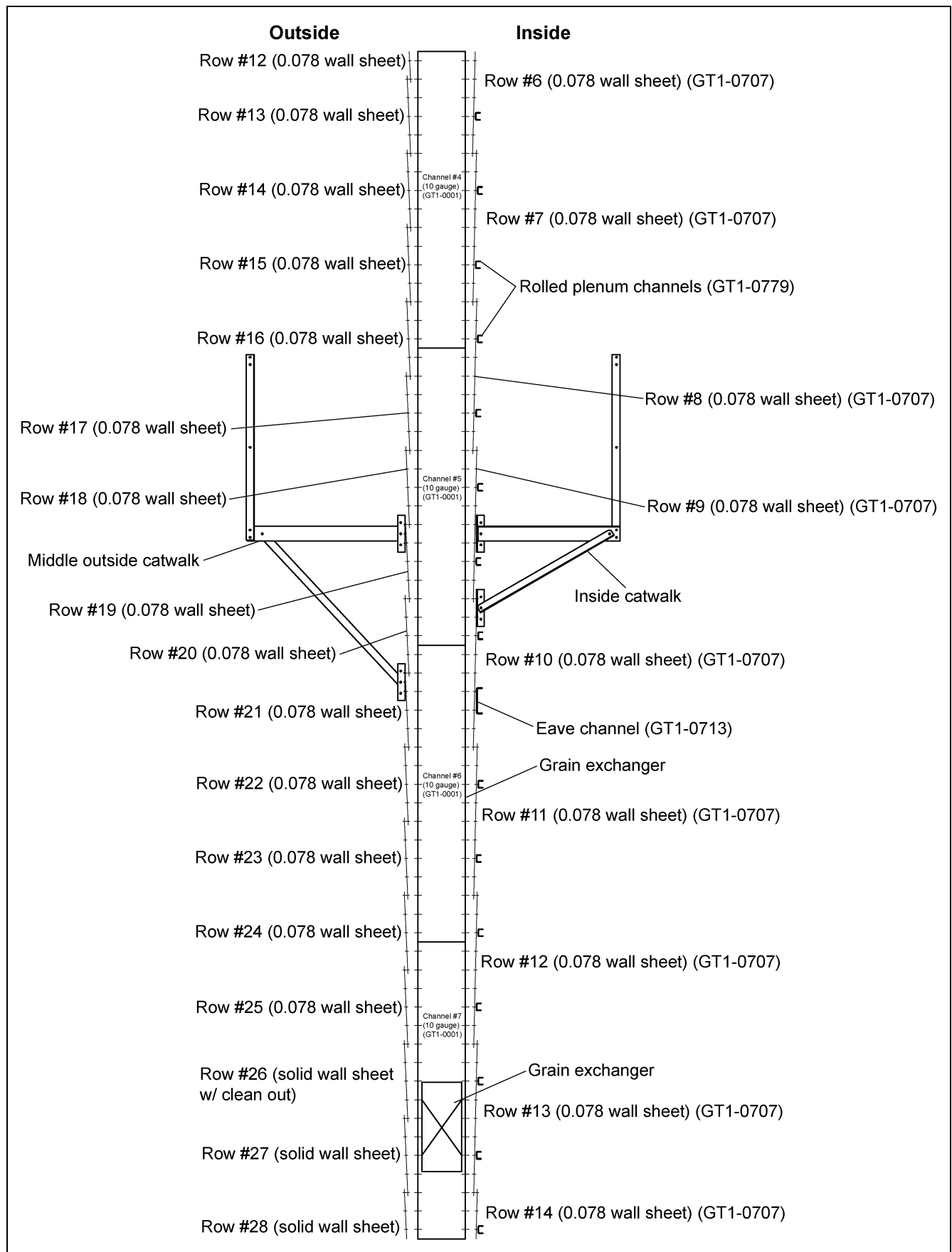

Figure 261 Clip Placement Z-10K Channels 4 to 7

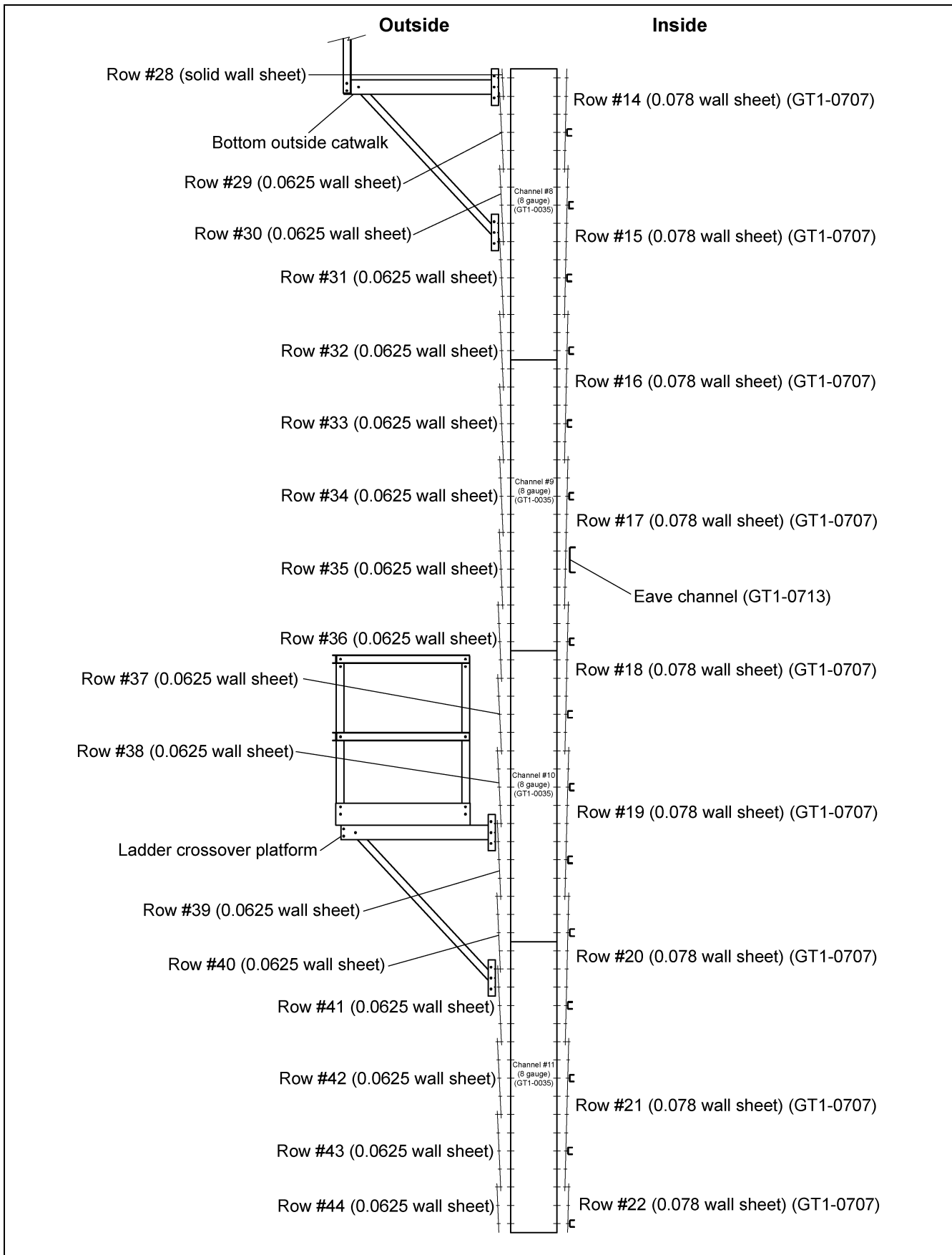

Figure 26J Clip Placement Z-10K Channels 8 to 11

26. All Tower Dryer Models Drawings

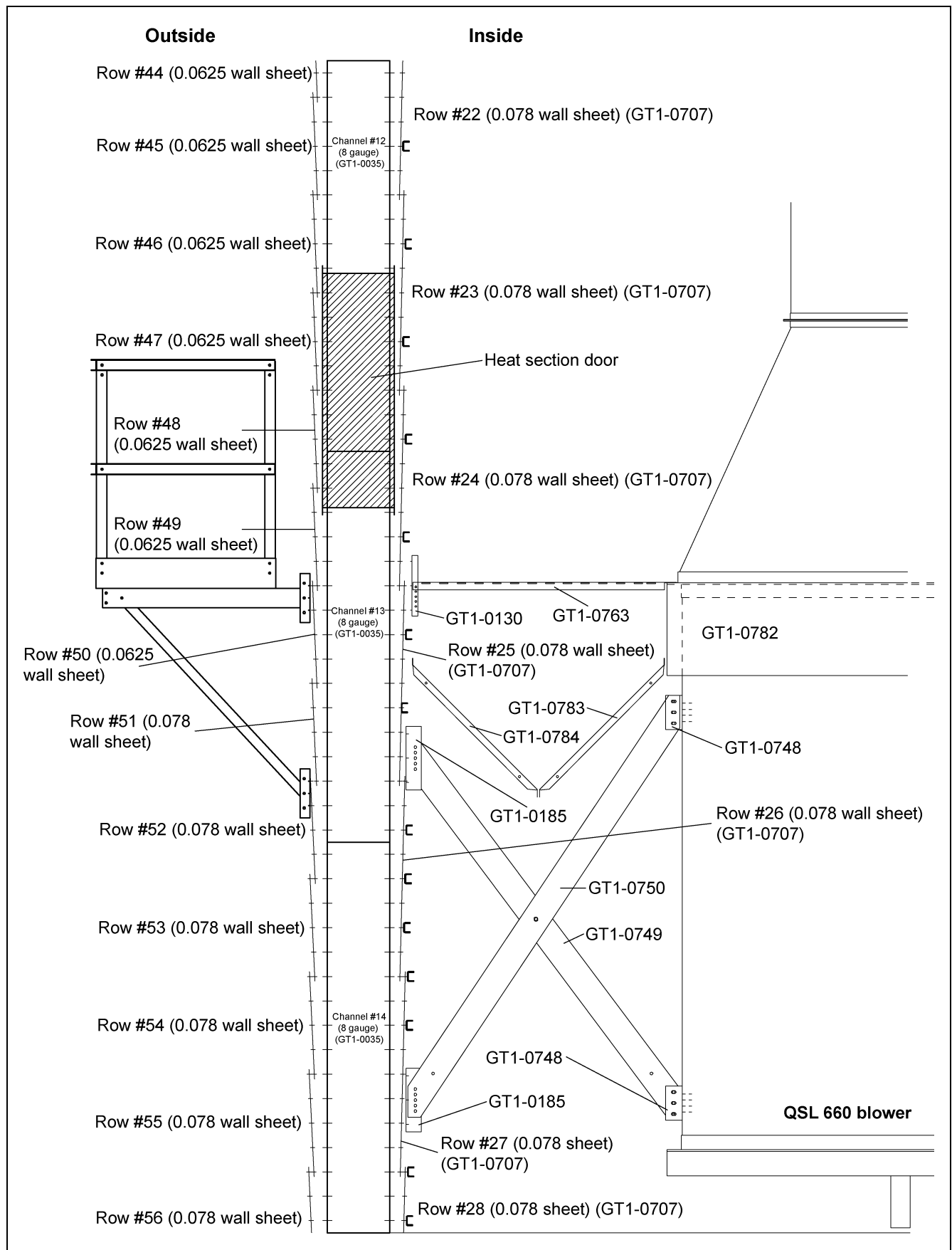

Figure 26K Clip Placement Z-10K w/ QSL Blowers Channels 12 to 14

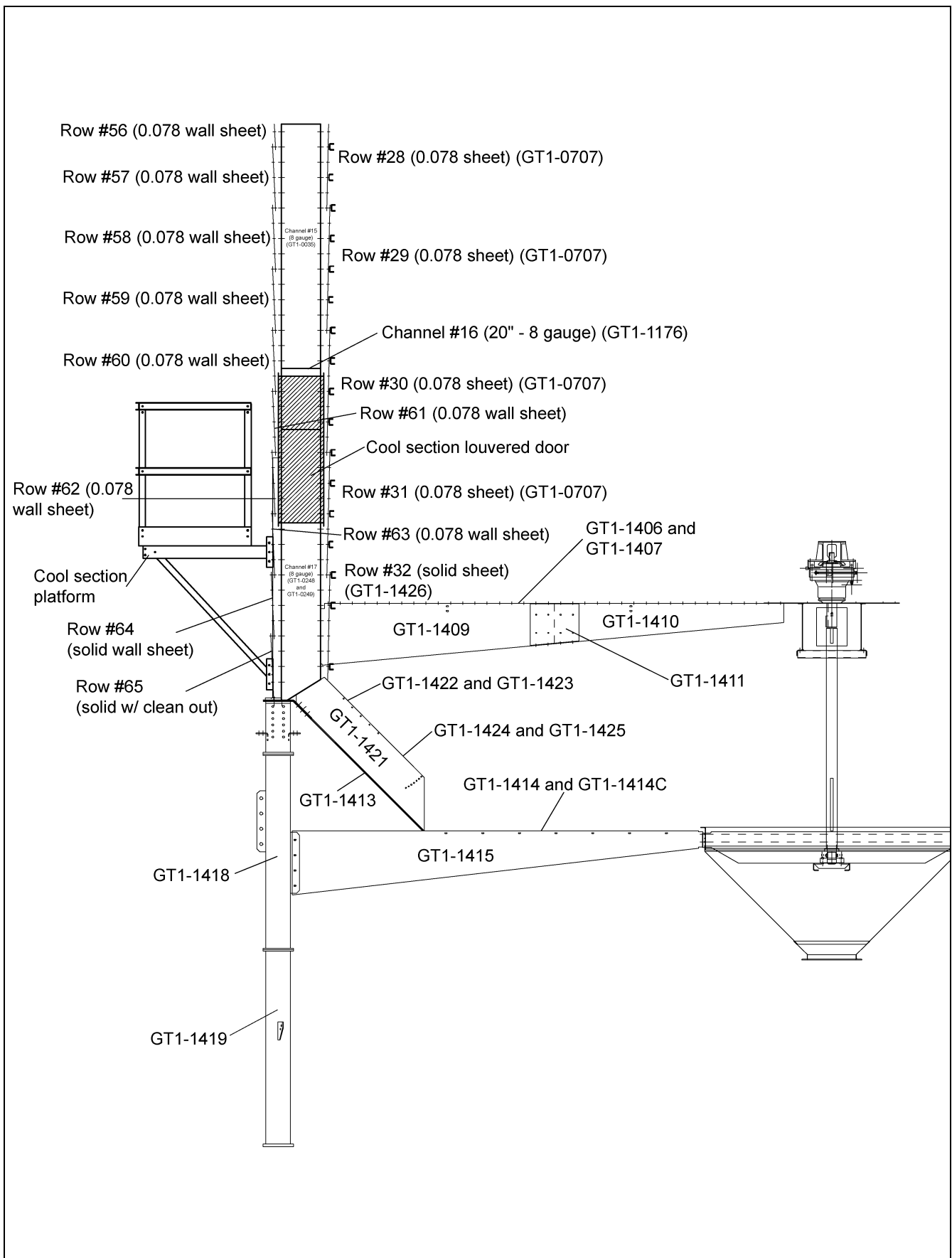

Figure 26L Clip Placement Z-10K Channels 15 to 17

26. All Tower Dryer Models Drawings

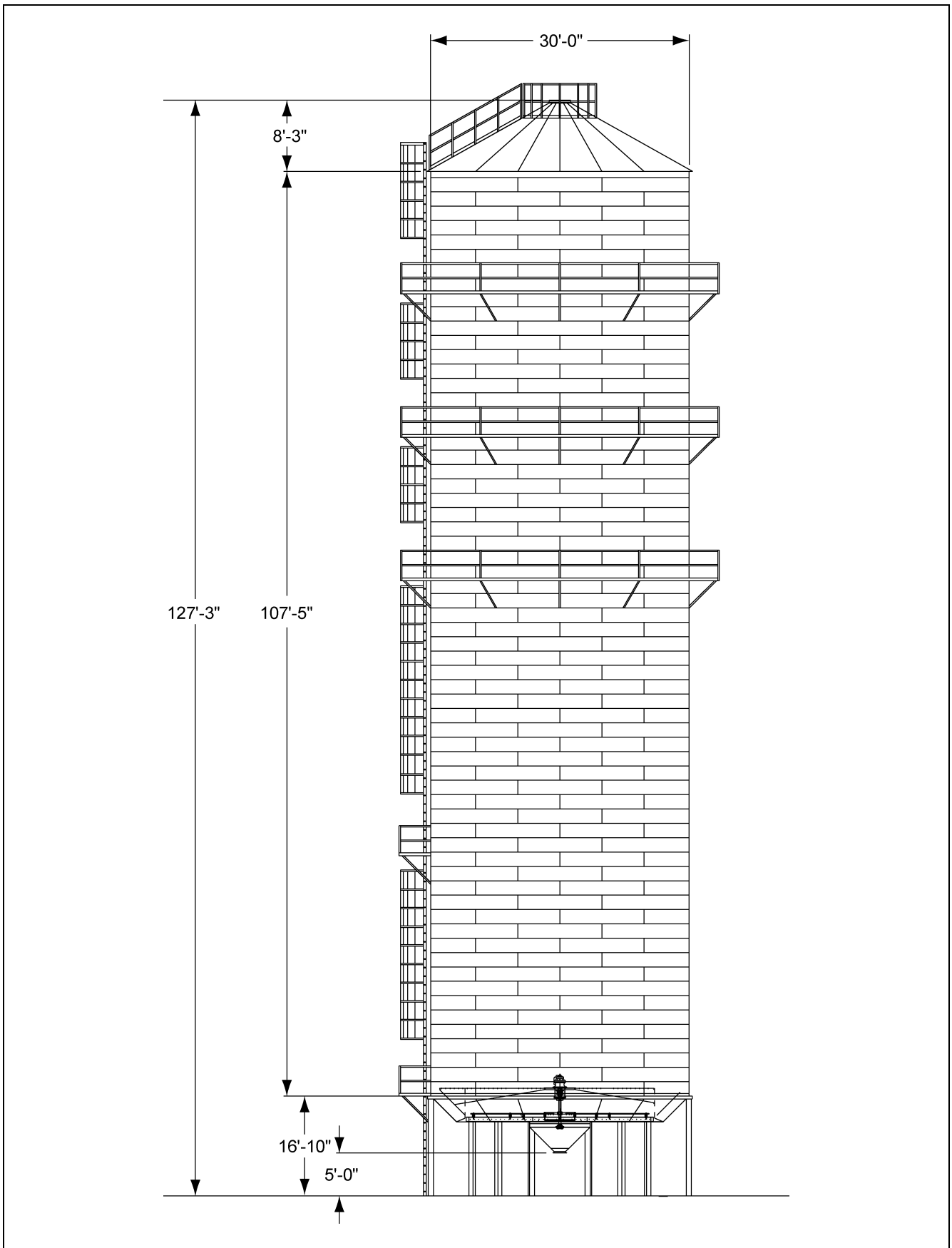

Figure 26M Zimmerman Tower Dryer Model Z-10000

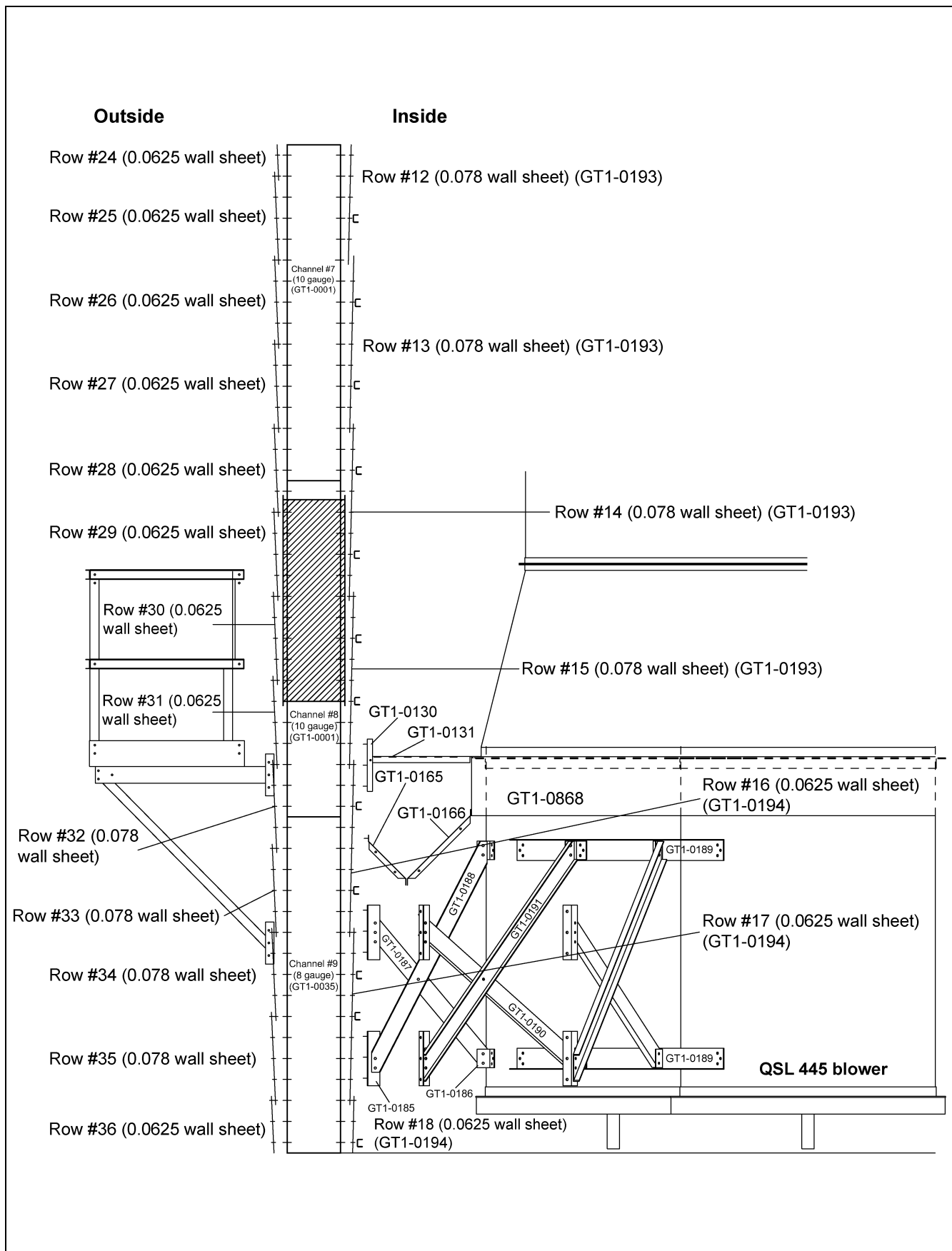

Figure 26N Clip Placement Z-3531 Channels 7 to 9 QSL Blowers

26. All Tower Dryer Models Drawings

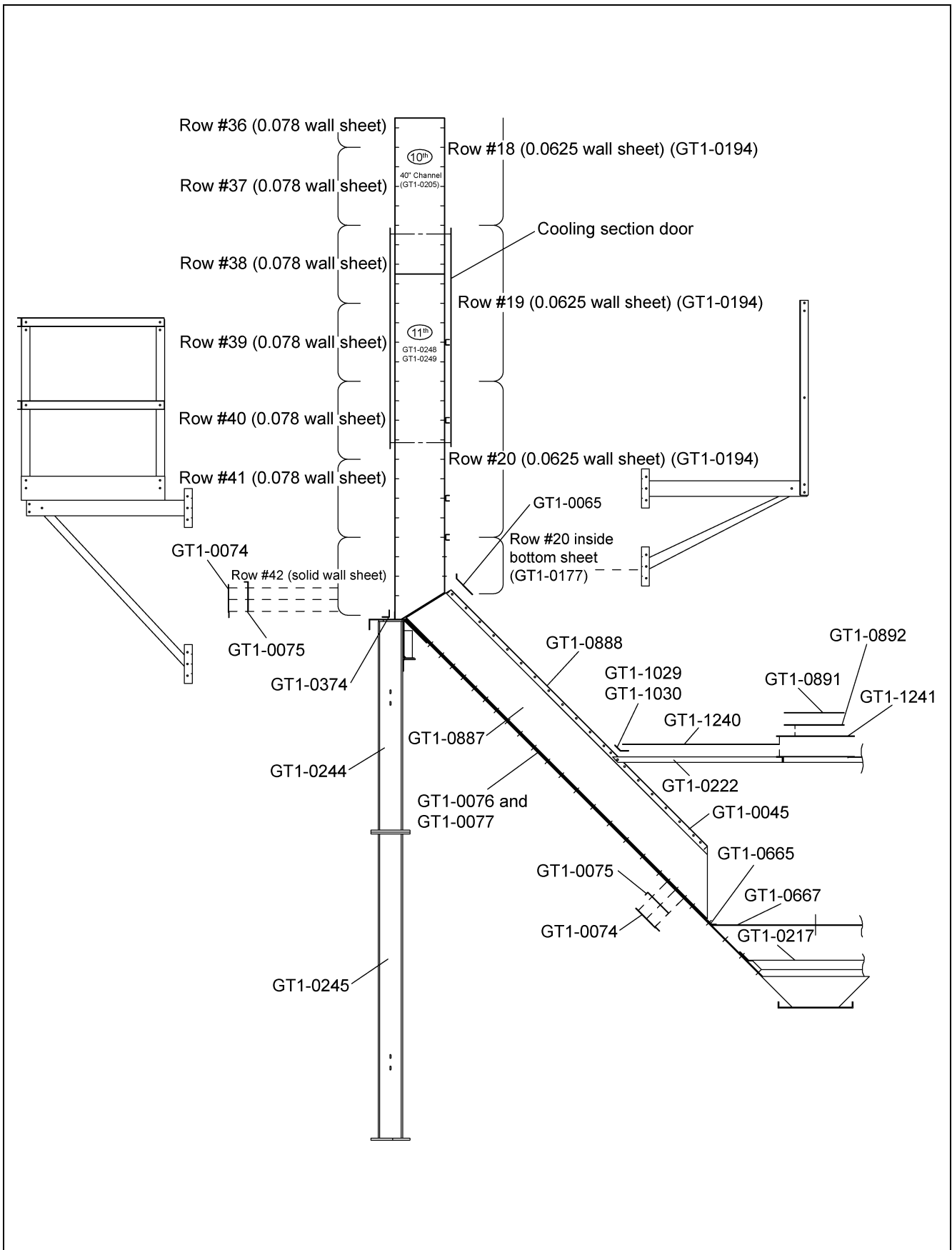

Figure 260 Model 3500 Hopper Detail

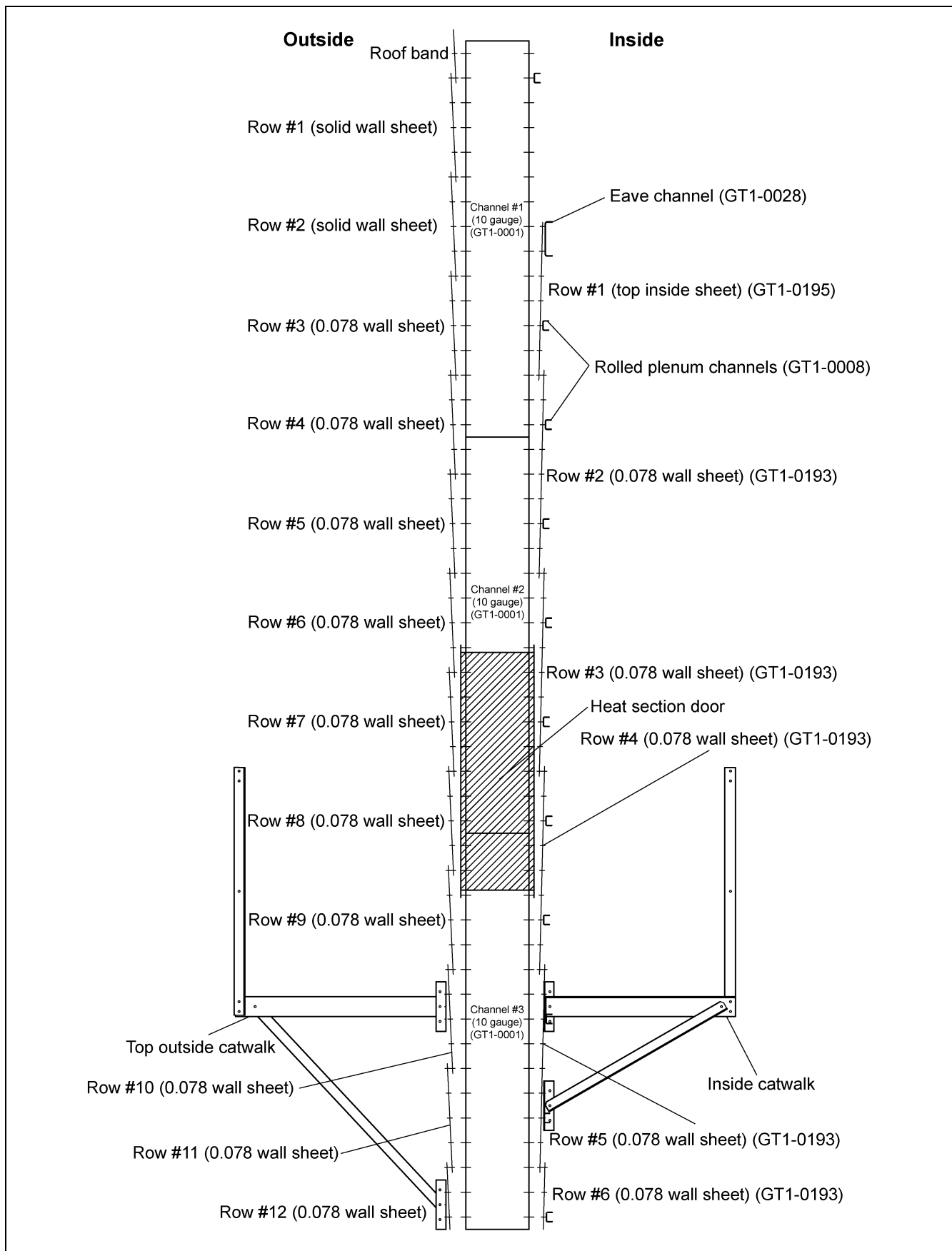

Figure 26P Clip Placement Z-3531 Channels 1 to 3

26. All Tower Dryer Models Drawings

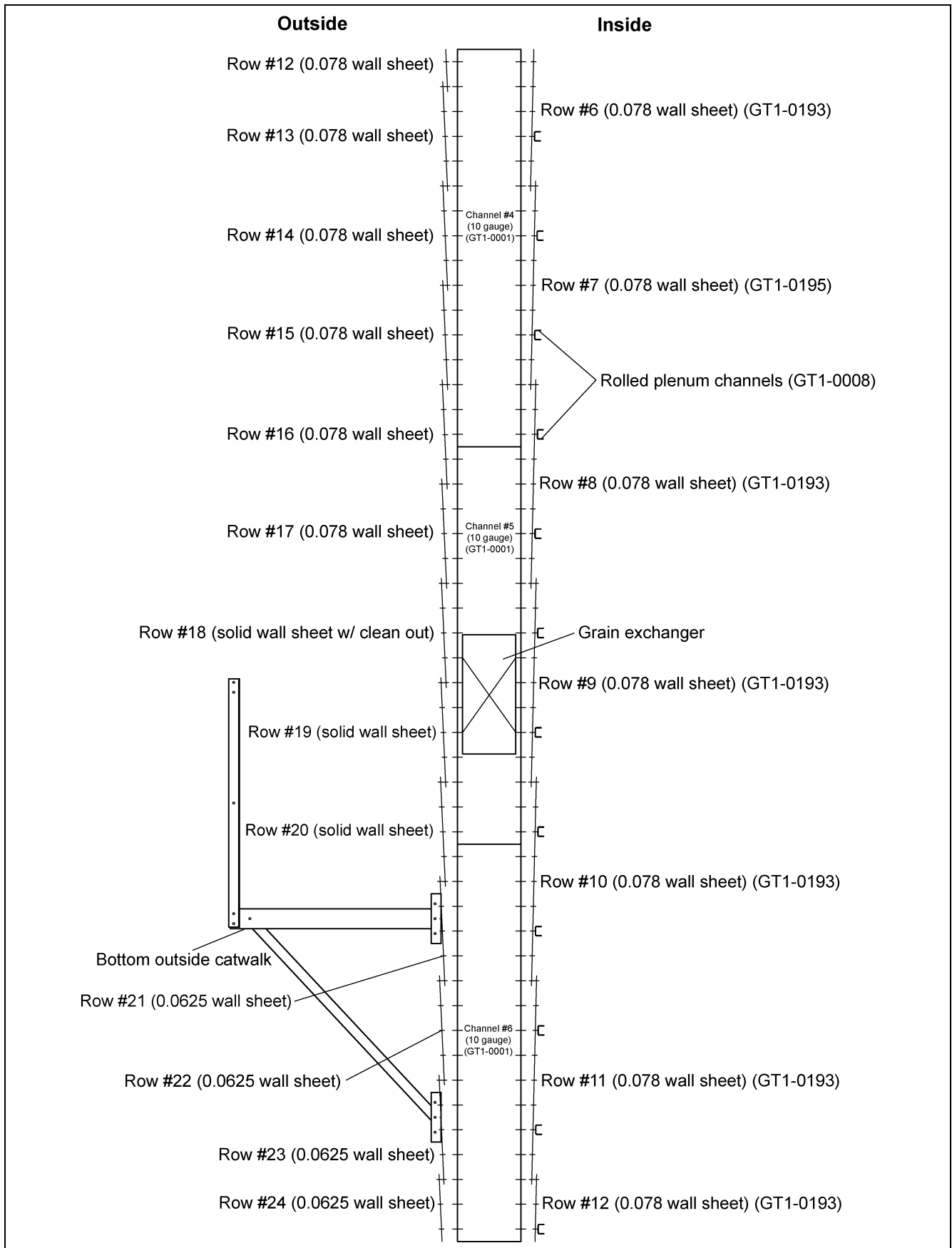

Figure 26Q Clip Placement Z-3531 Channels 4 to 6

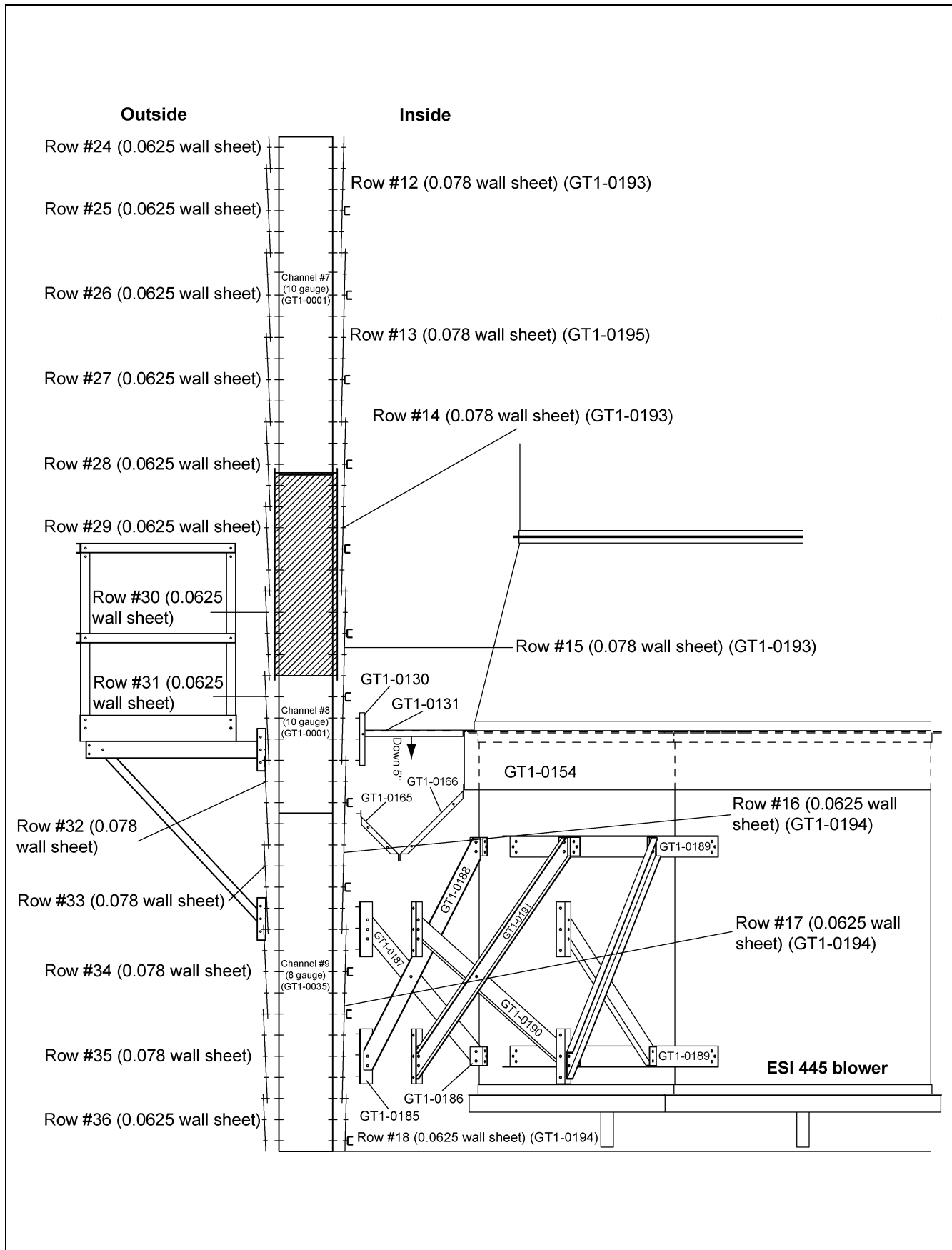

Figure 26R Clip Placement Z-3531 Channels 7 to 9

26. All Tower Dryer Models Drawings

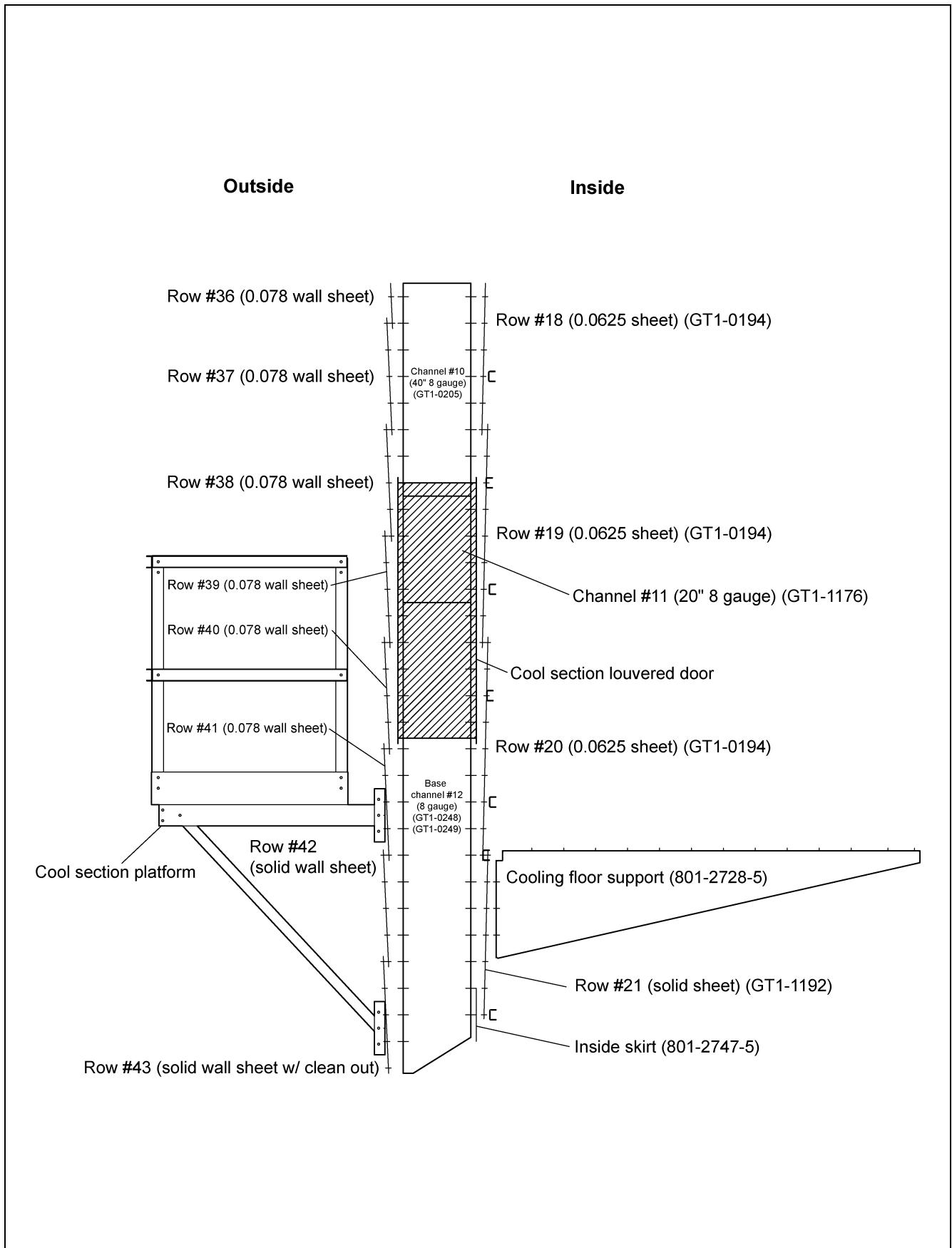

Figure 26S Clip Placement Z-3531 Channels 10 to 12

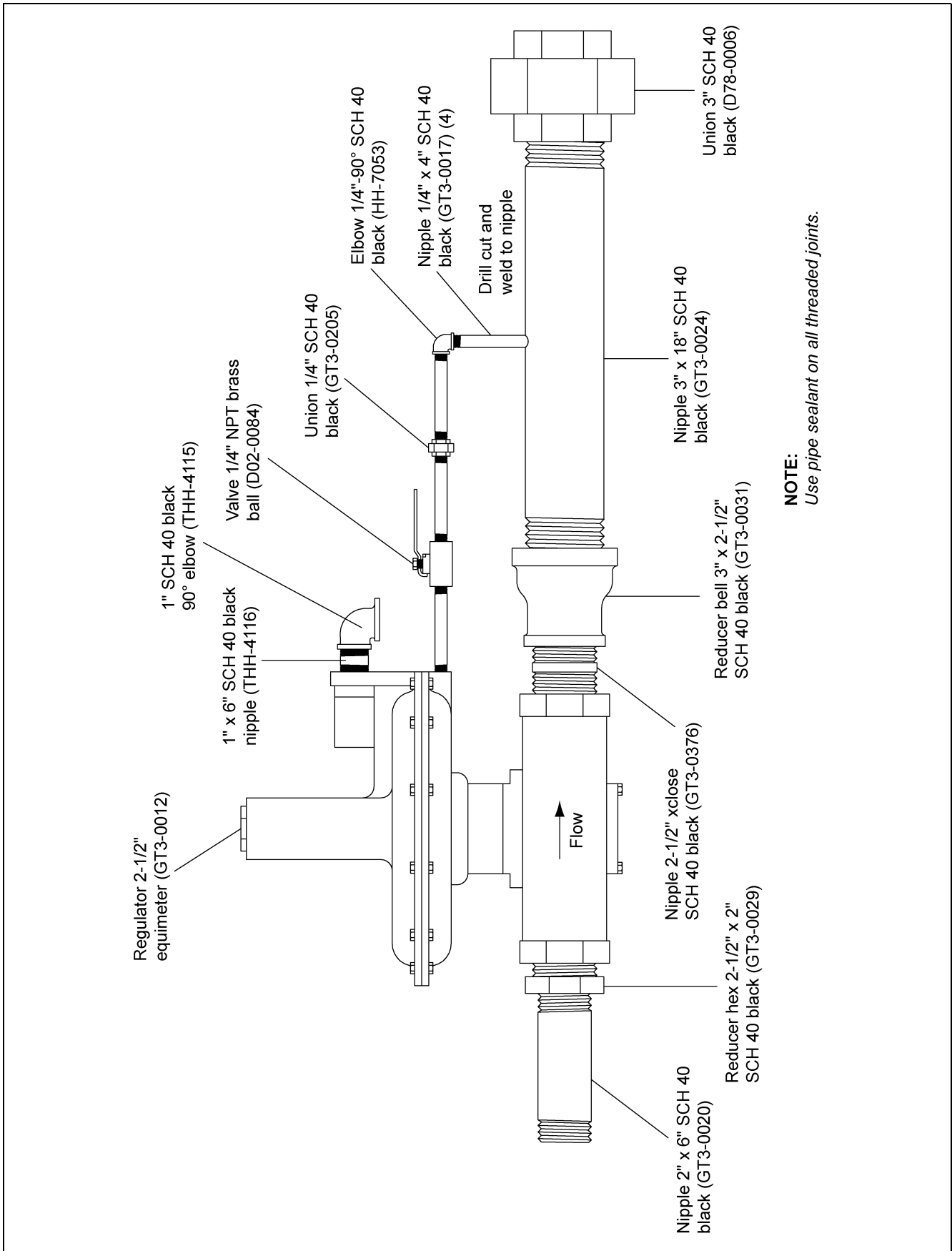
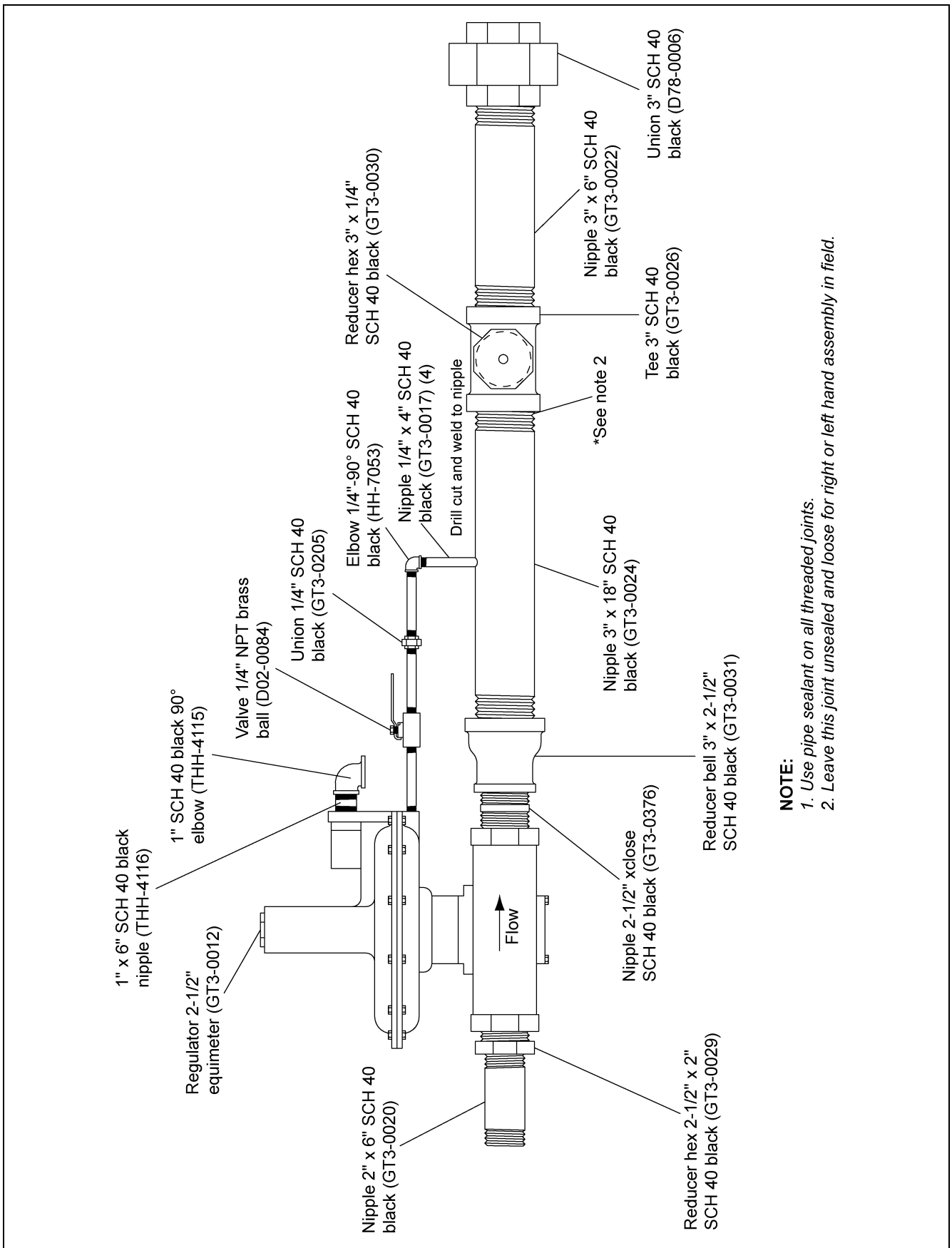

Figure 26T 3" Regulator Section - Domestic

26. All Tower Dryer Models Drawings



NOTE:

1. Use pipe sealant on all threaded joints.
2. Leave this joint unsealed and loose for right or left hand assembly in field.

Figure 26U 3" Regulator Section - Canadian

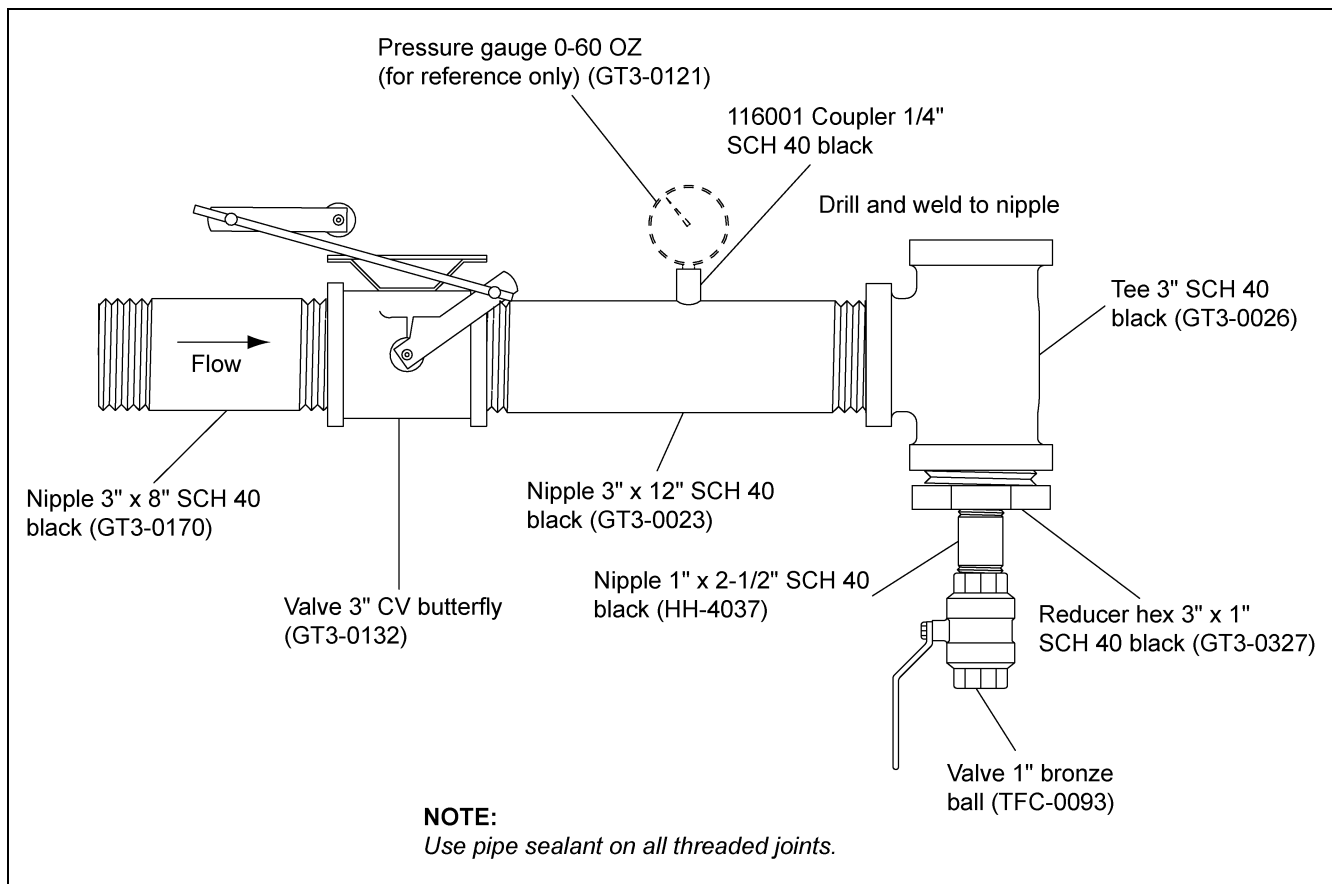

Figure 26V 3" Modulator Section - Domestic

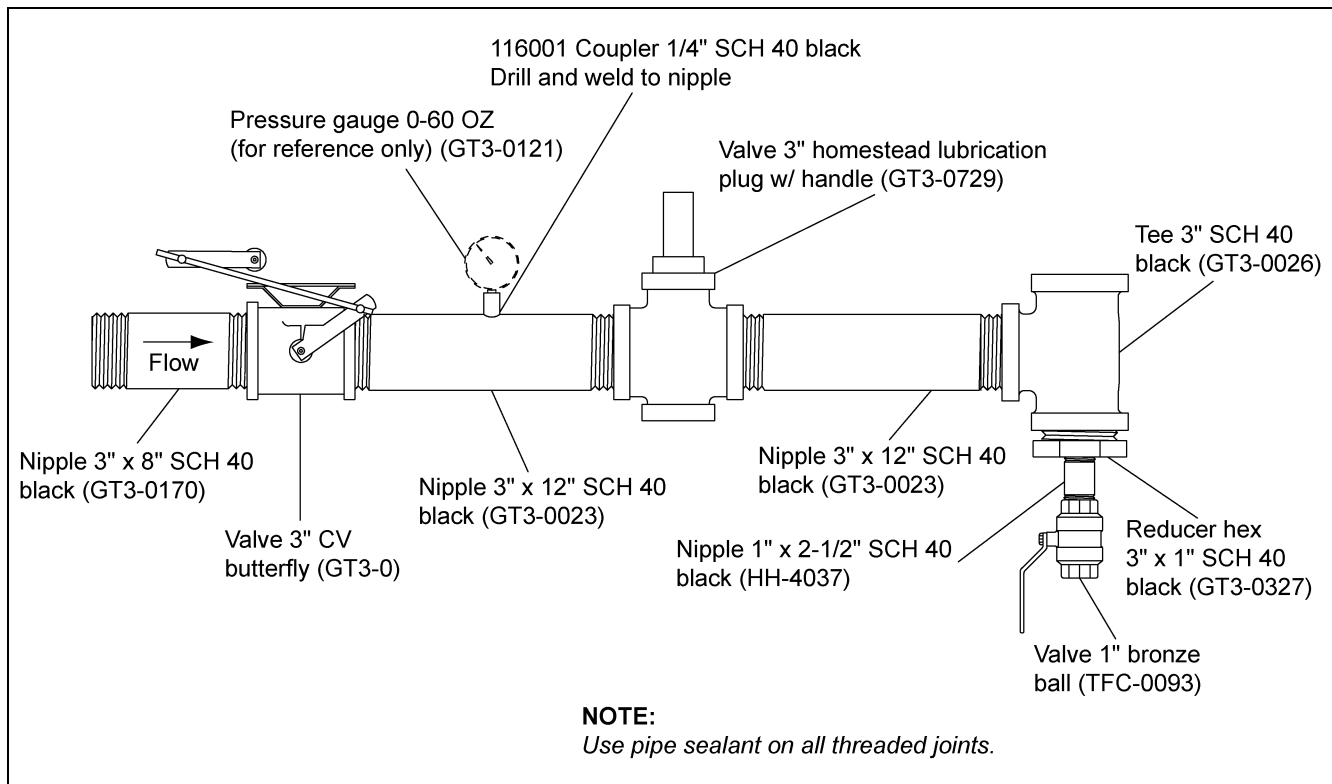

Figure 26W 3" Modulator Section - Cargill

26. All Tower Dryer Models Drawings

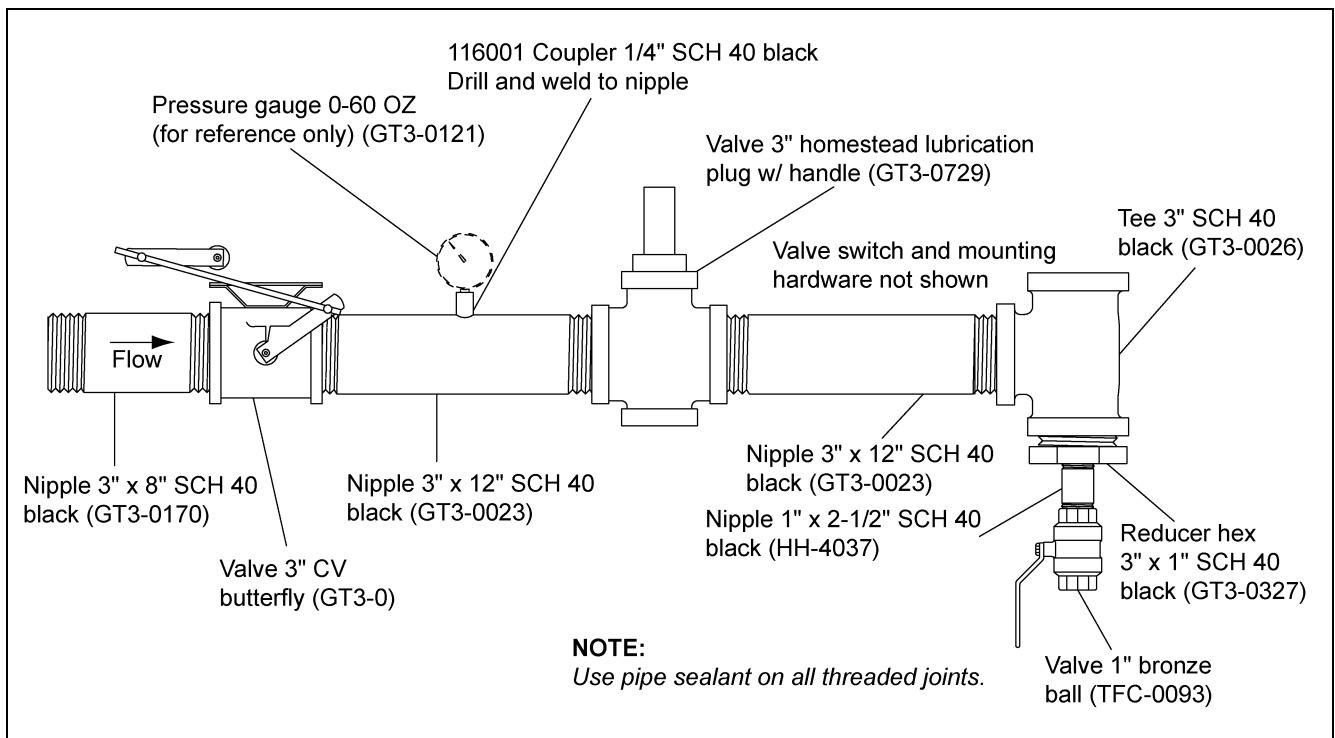

Figure 26X 3" Modulator Section - Canadian

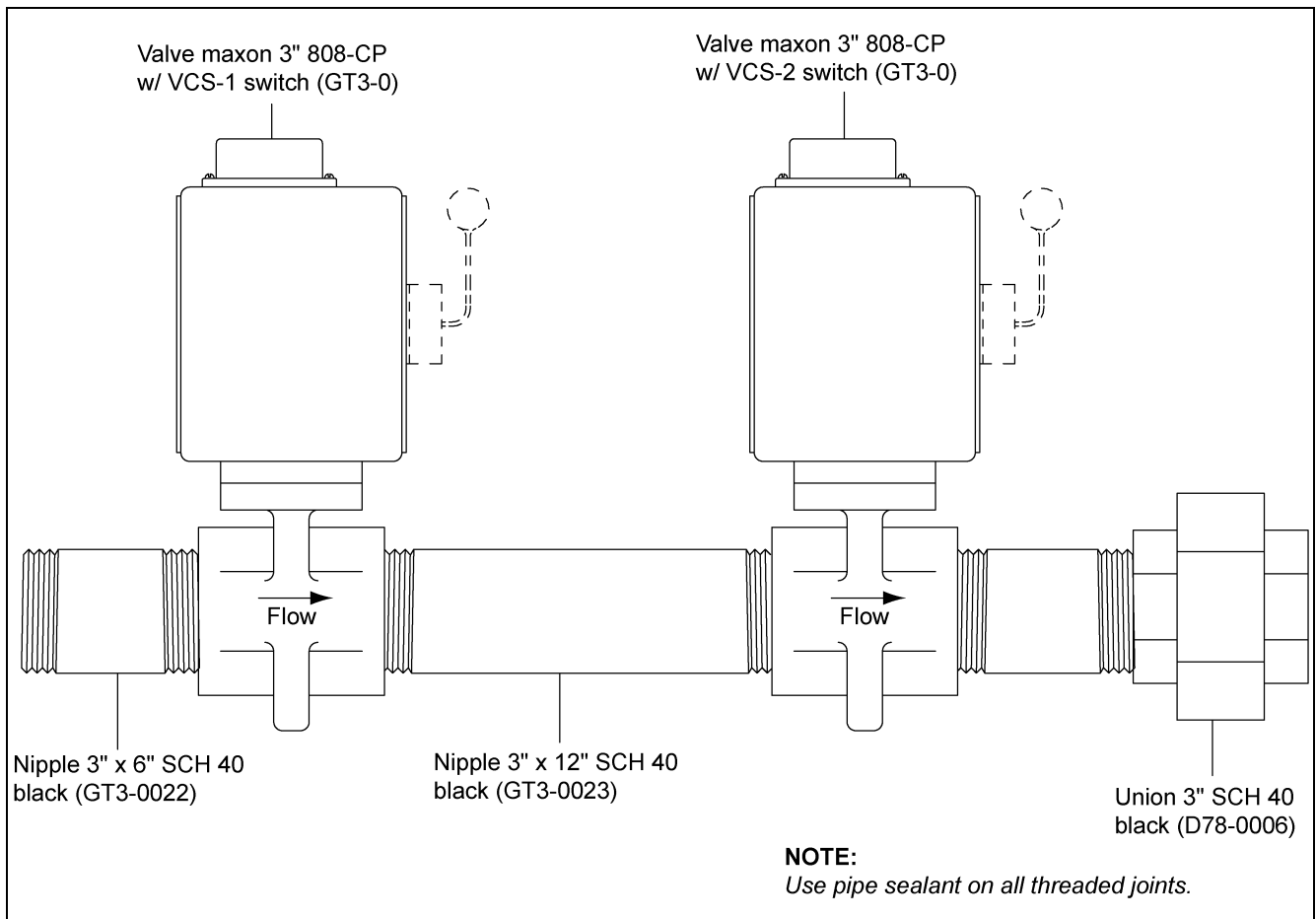

Figure 26Y 3" Maxon Section - Domestic

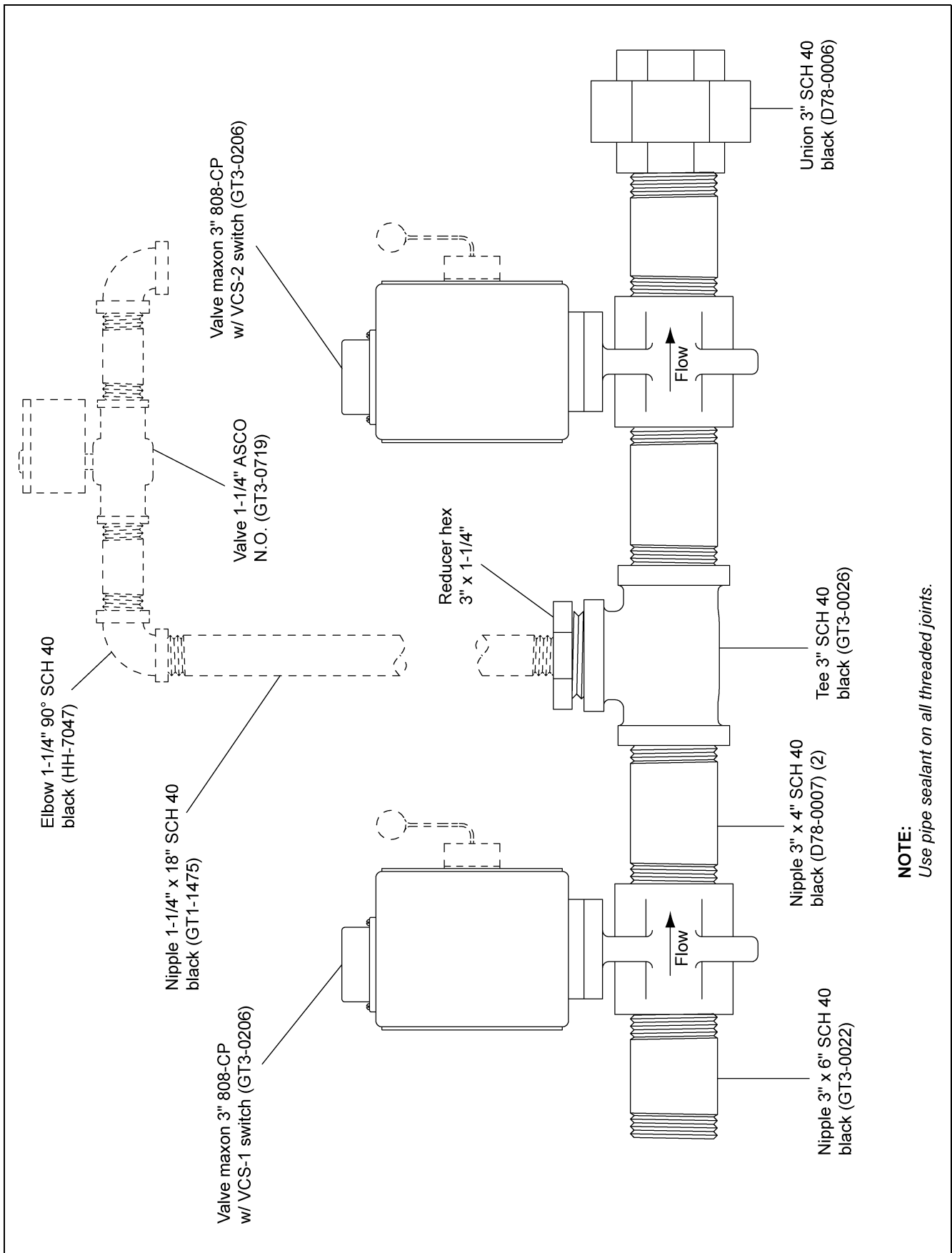

Figure 26Z 3" Maxon Section - Canadian

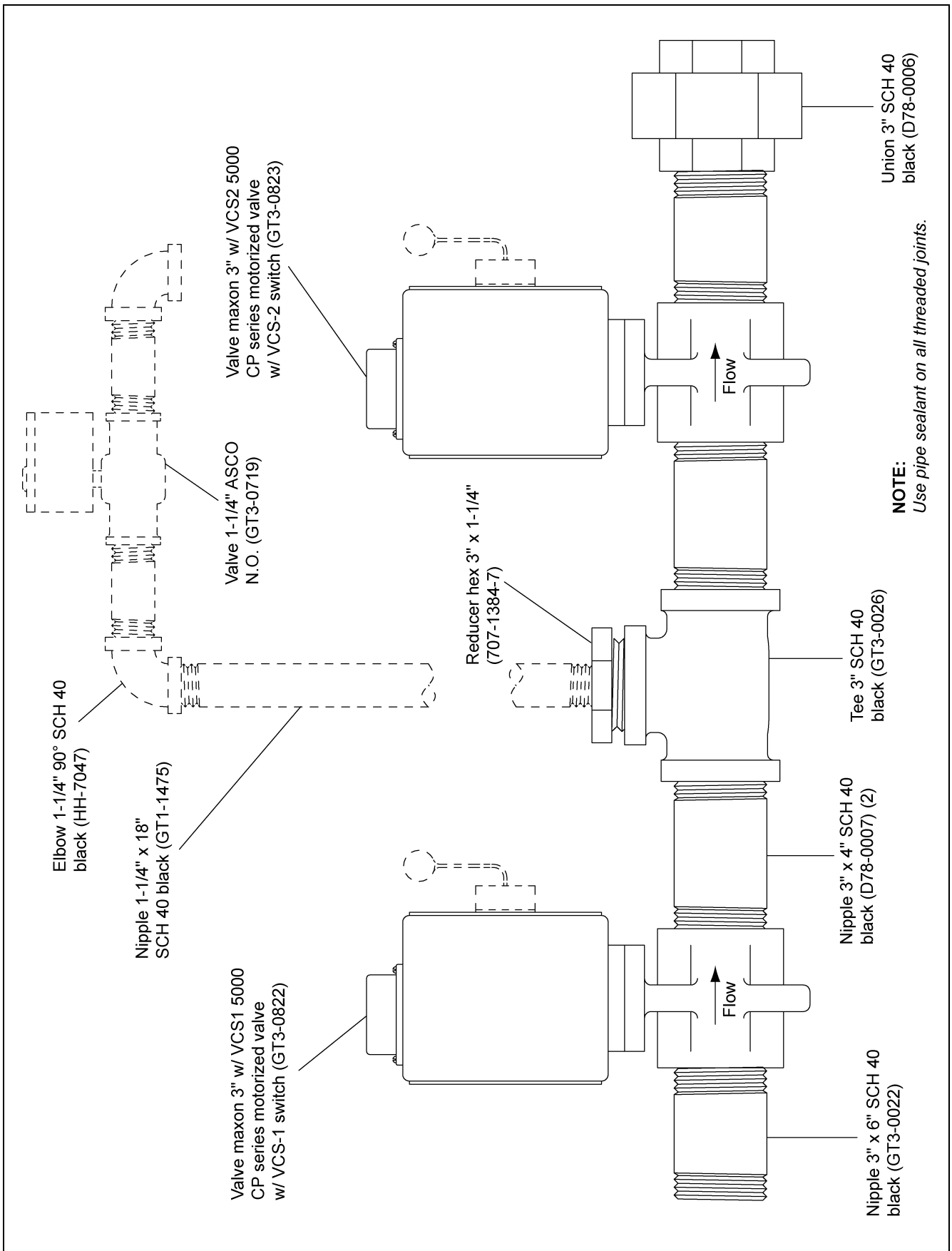

Figure 26AA 3" Maxon Section - Canadian-Motorized

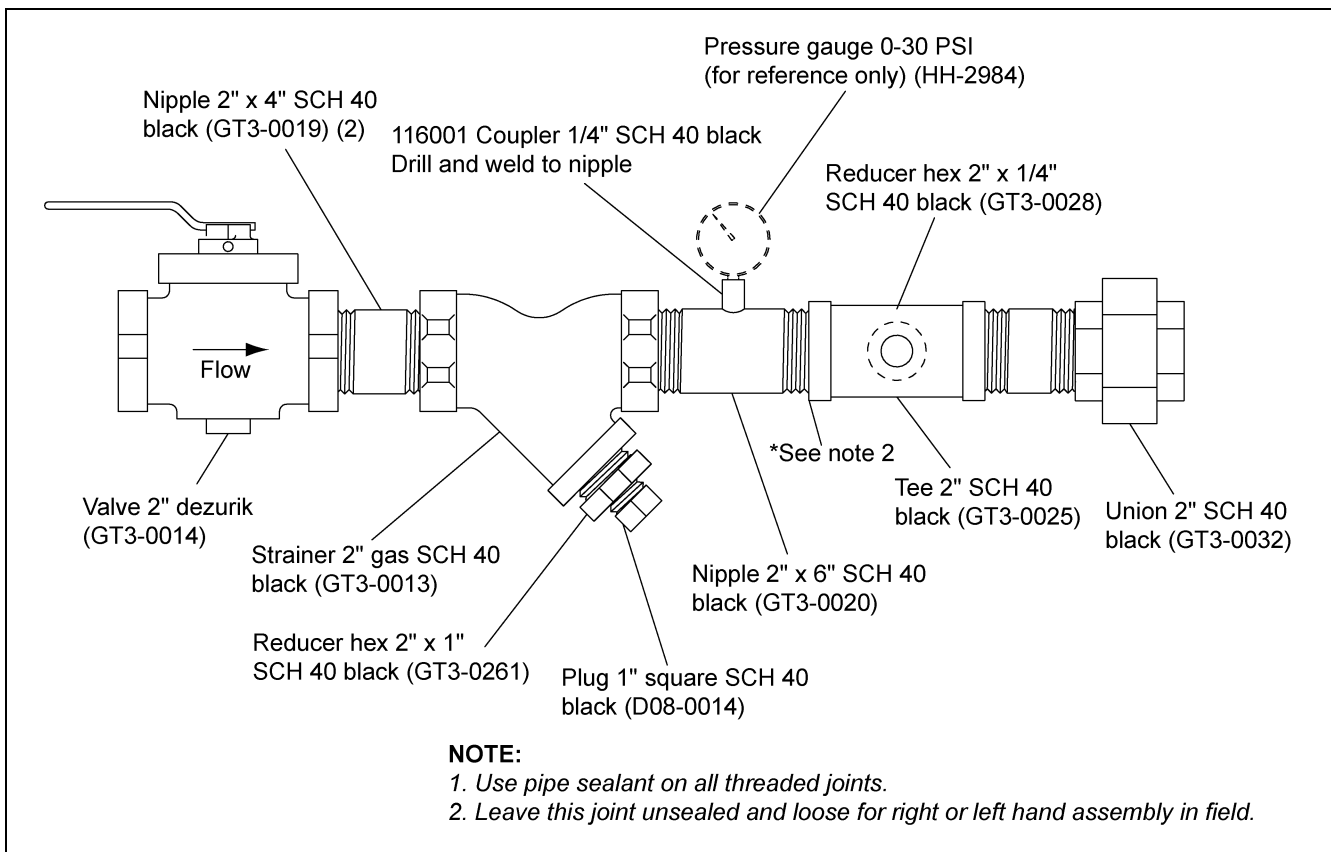

Figure 26AB 2" Shut Off Section - Domestic

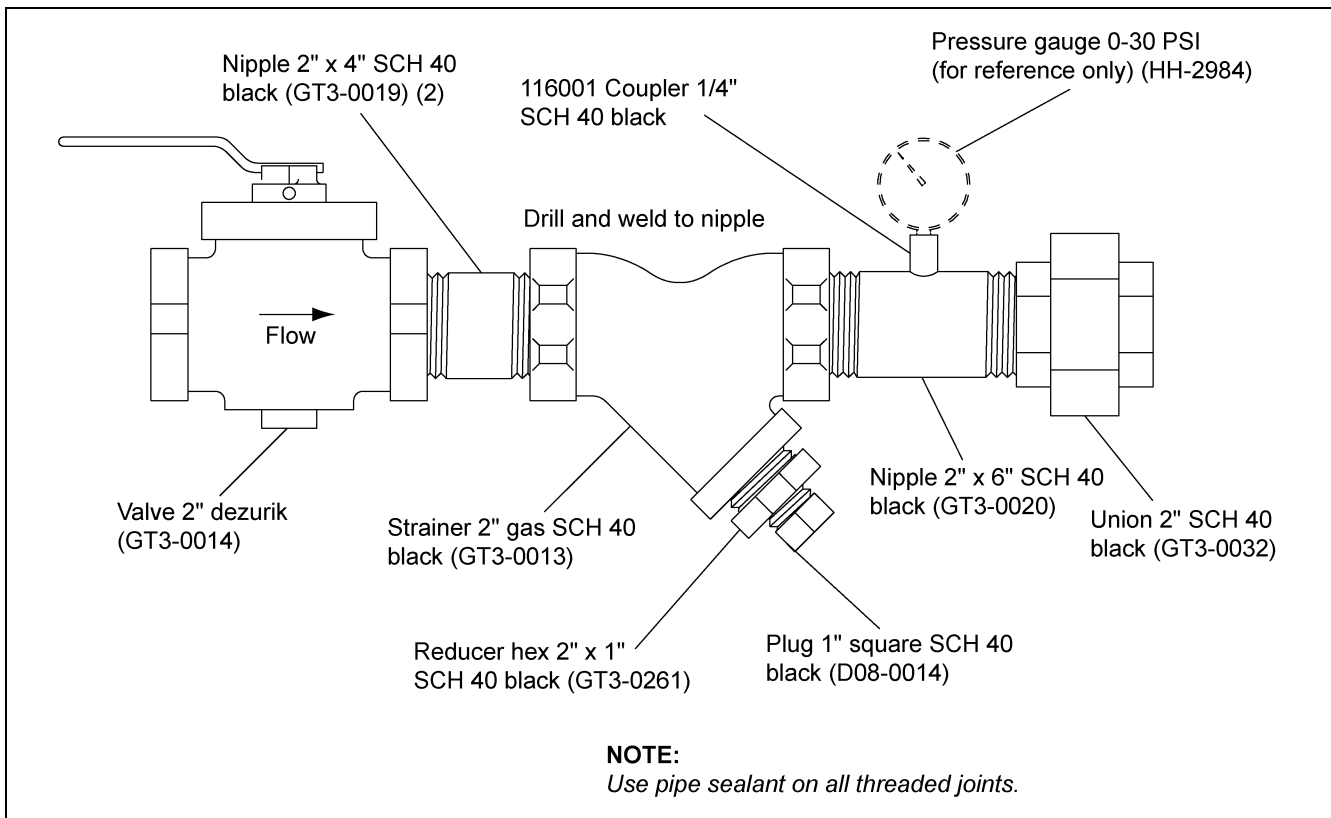

Figure 26AC 2" Shut Off Section - Canadian

26. All Tower Dryer Models Drawings

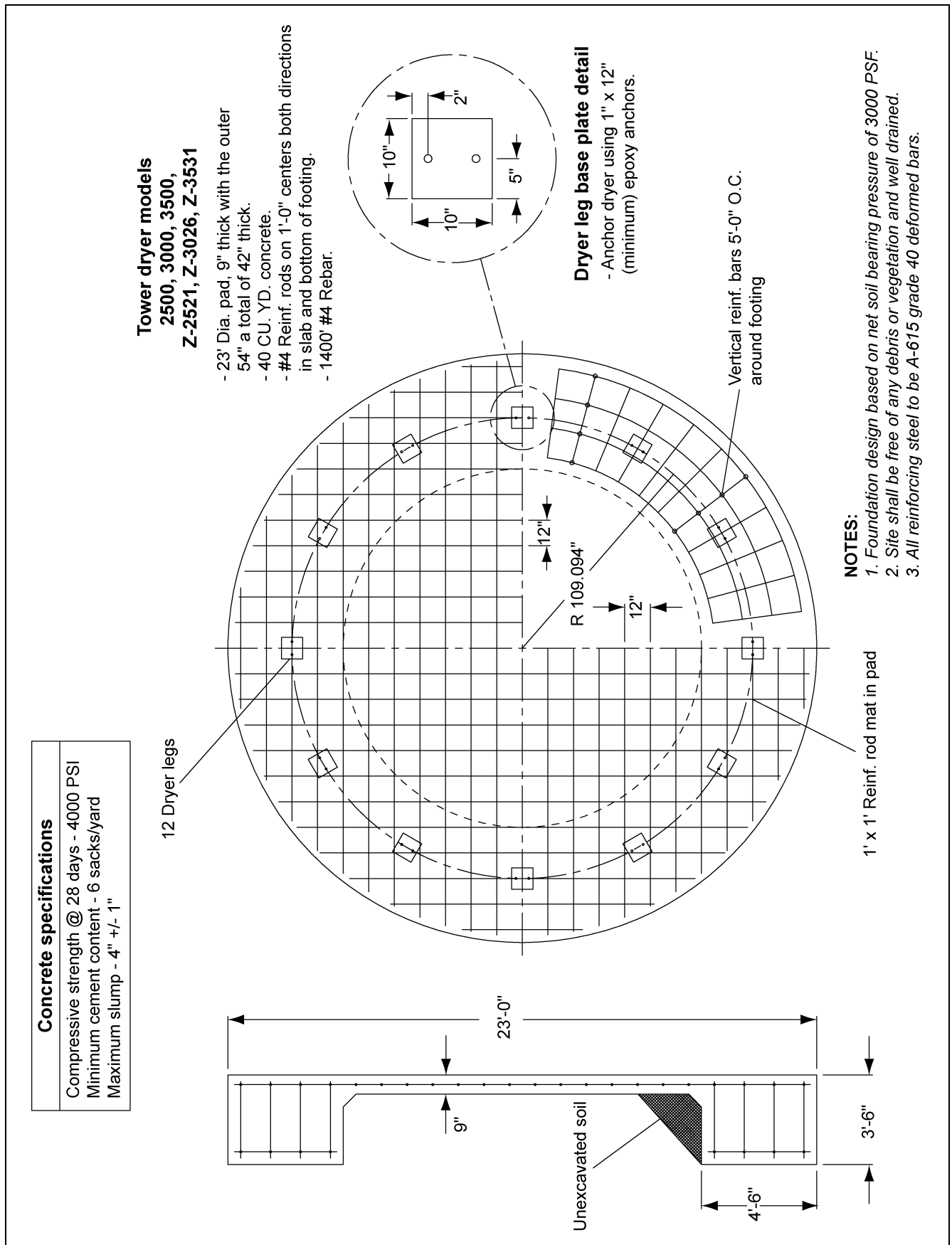

Figure 26AD Foundation Plan Central United States

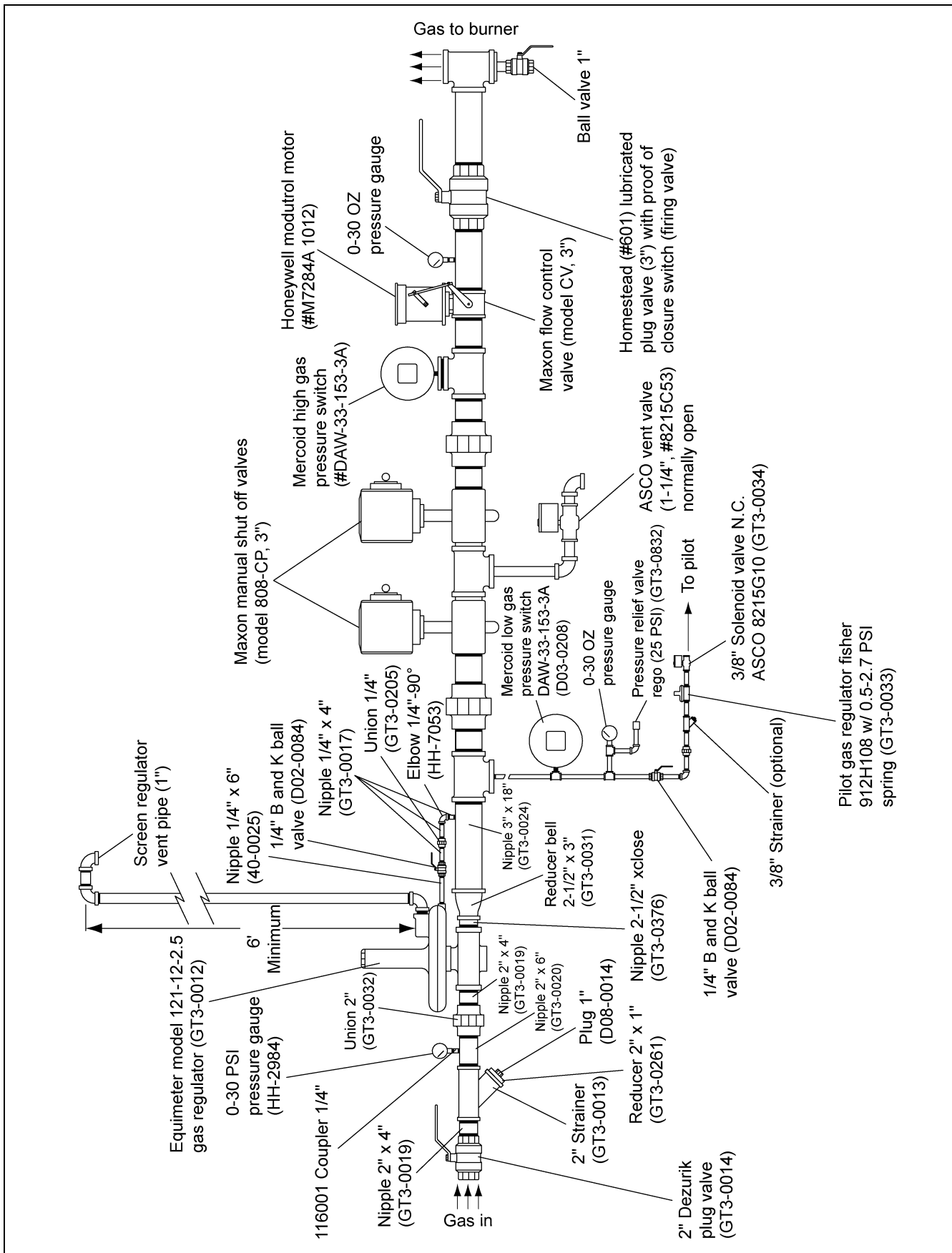

Figure 26AE Tower Dryer 3" Canadian Gas Train

26. All Tower Dryer Models Drawings

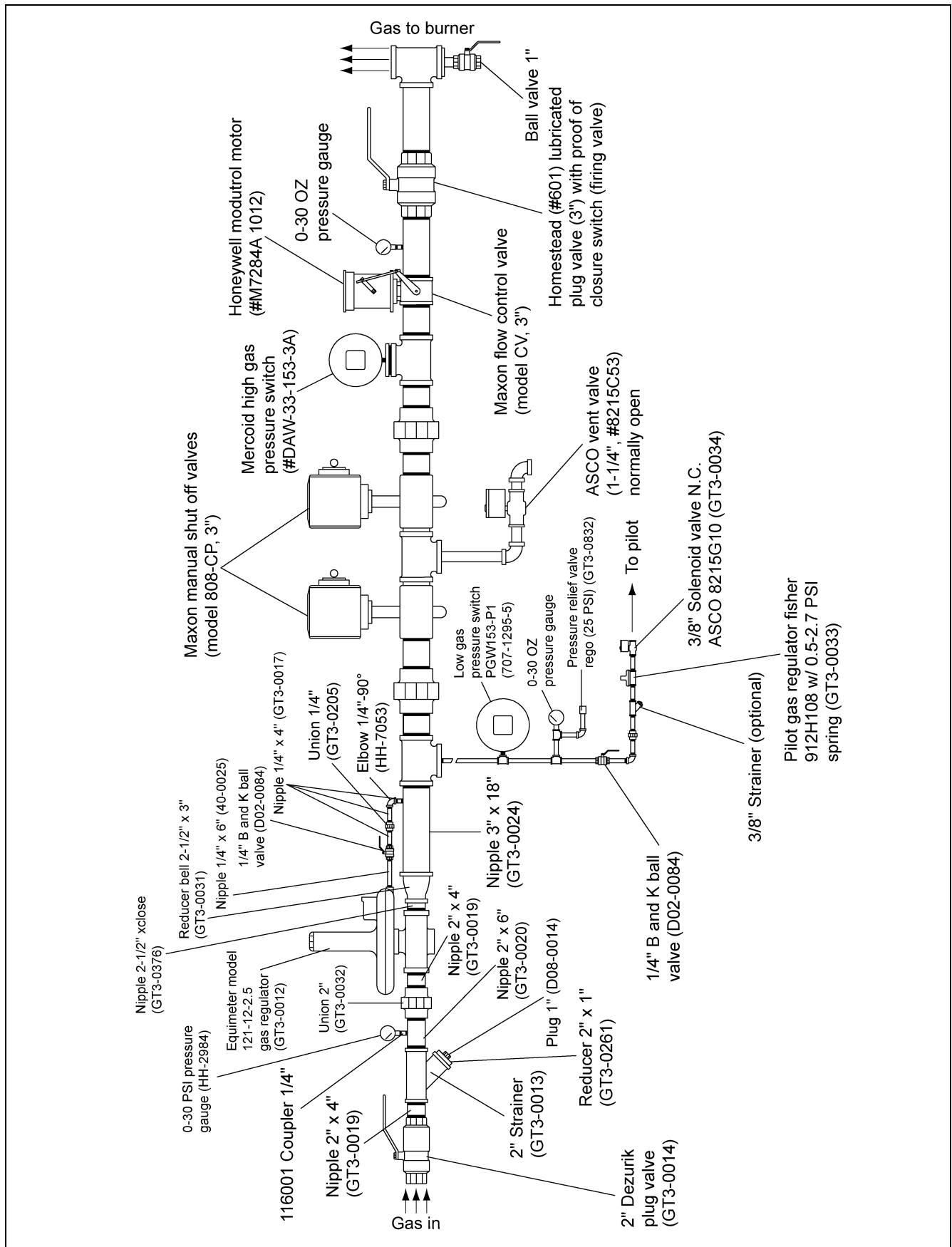

Figure 26AF Tower Dryer 3" Canadian Gas Train

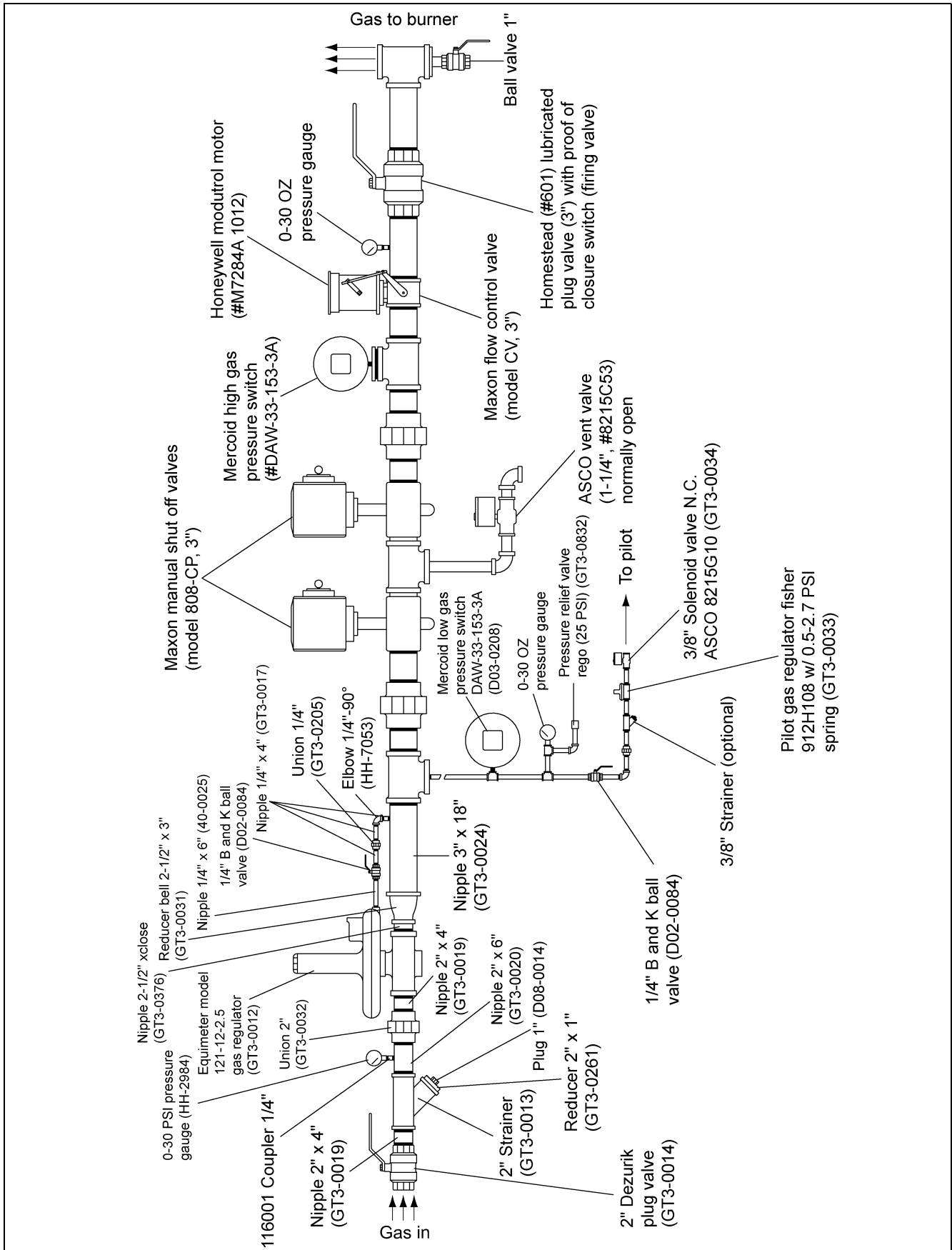

Figure 26AG Tower Dryer 3" Canadian Gas Train

26. All Tower Dryer Models Drawings

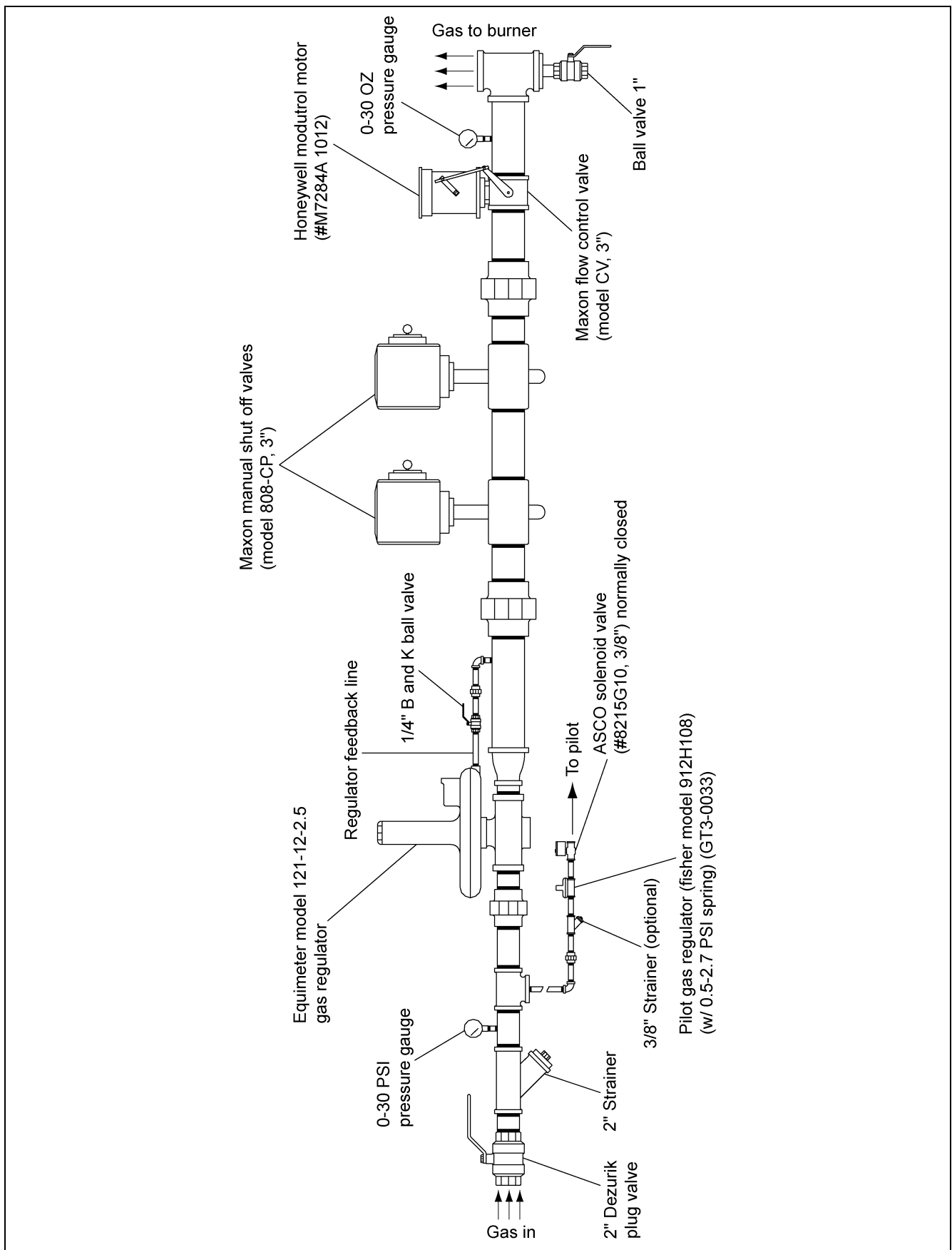

Figure 26AH Tower Dryer 3" Canadian Gas Train

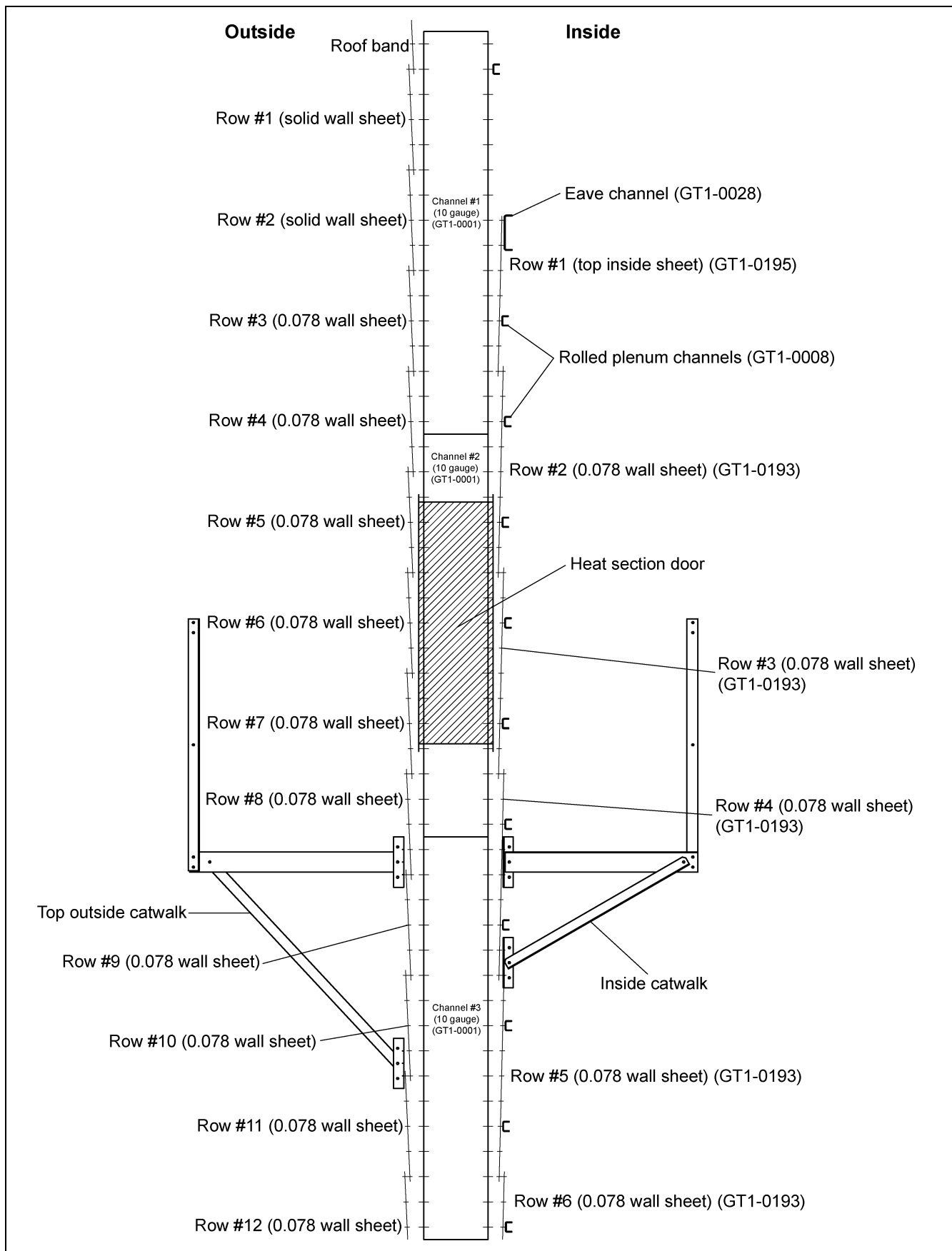
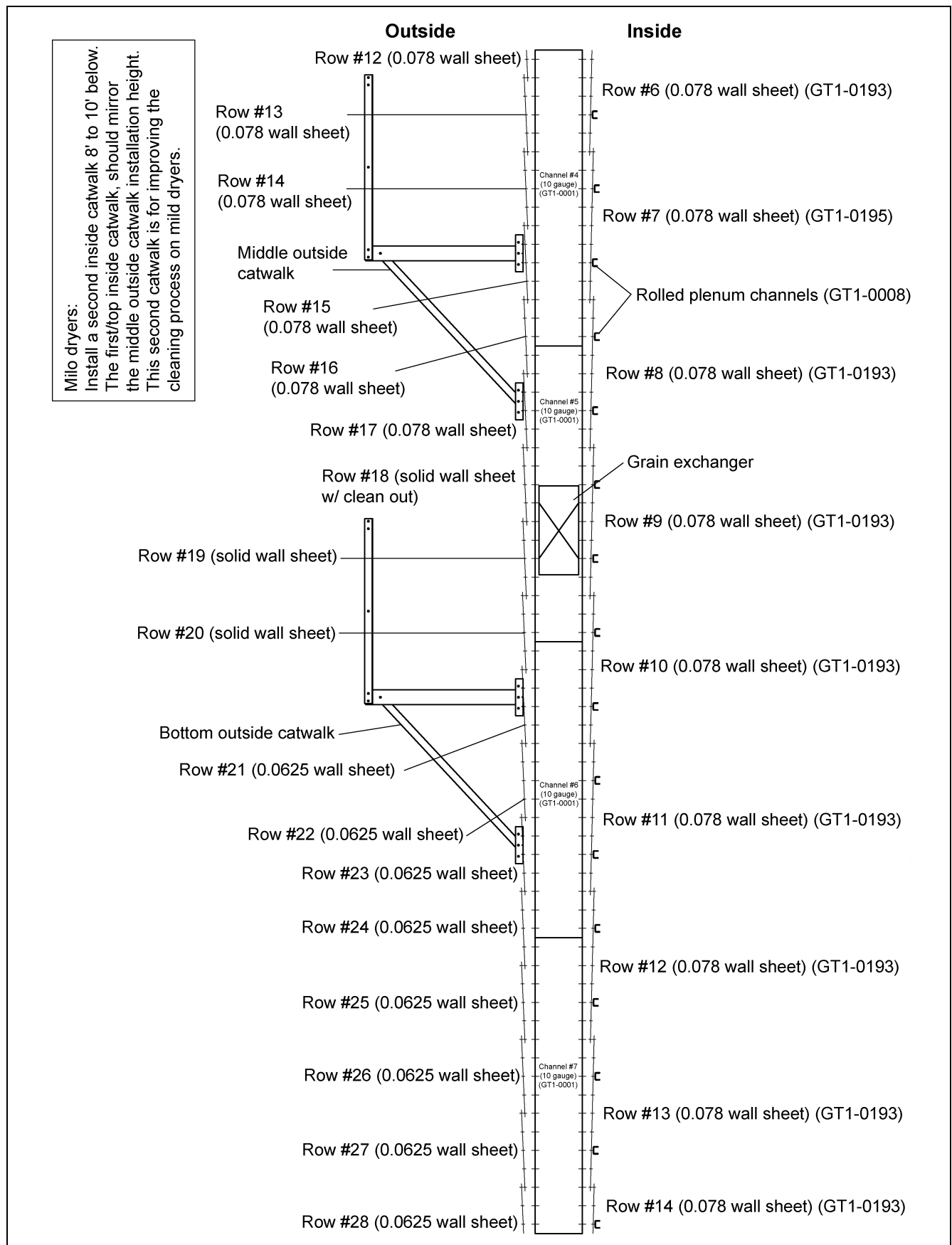

Figure 26AI Clip Placement Z-4036/G-4000 Channels 1 to 3

26. All Tower Dryer Models Drawings



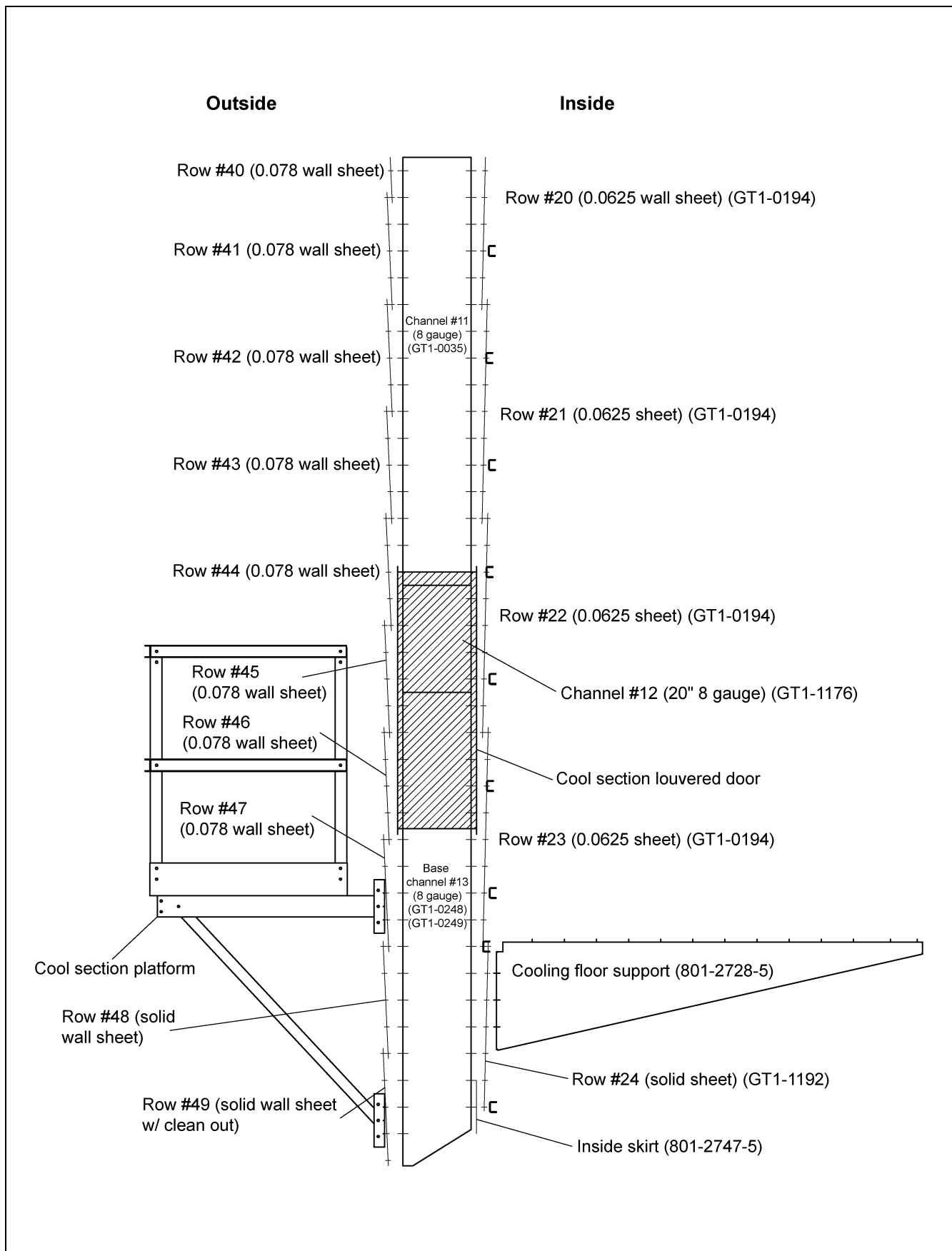

Figure 26AK Clip Placement Z-4036 Channels 11 to 13

26. All Tower Dryer Models Drawings

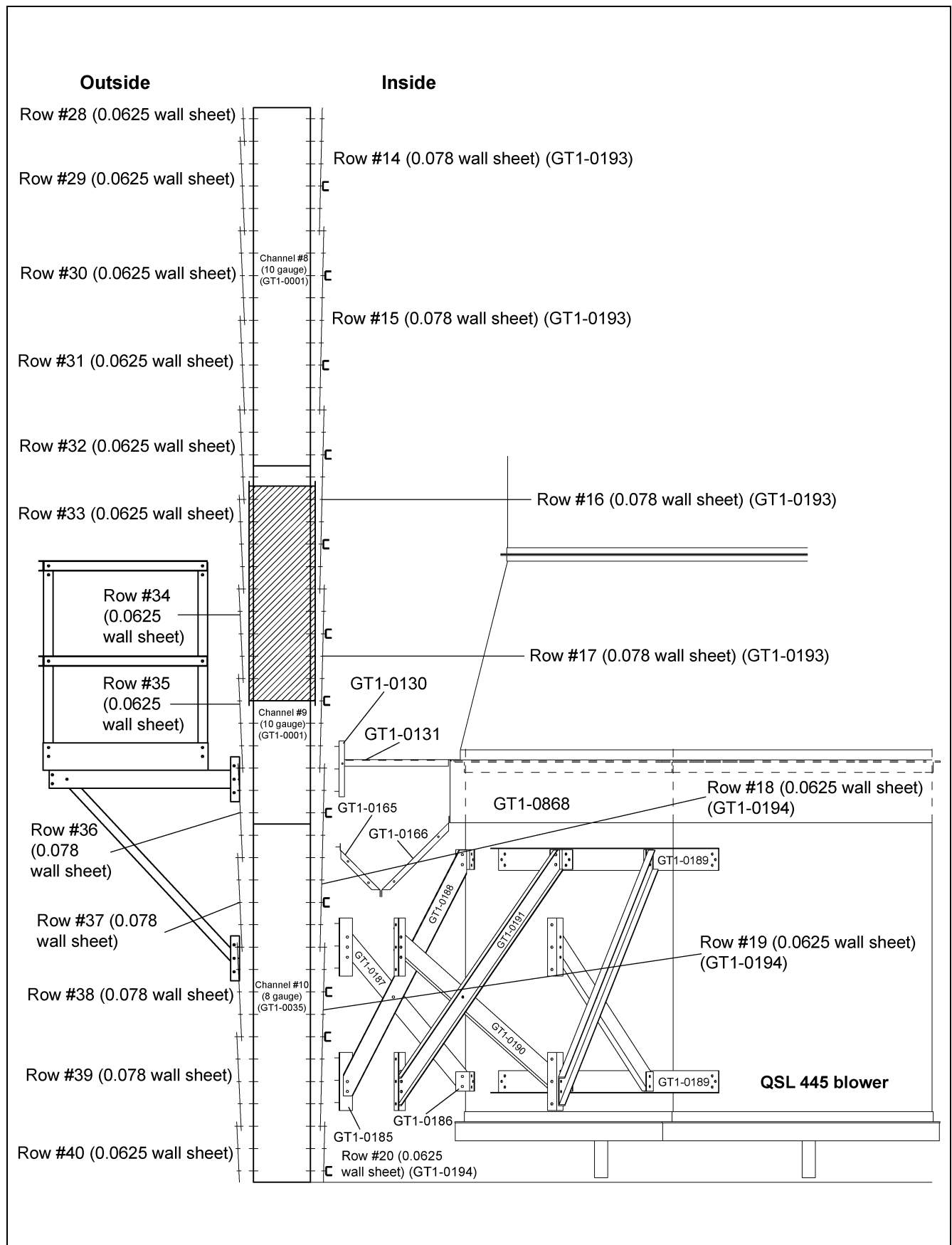

Figure 26AL Clip Placement Z-4036/G-4000 Channels 8 to 10 QSL Blowers

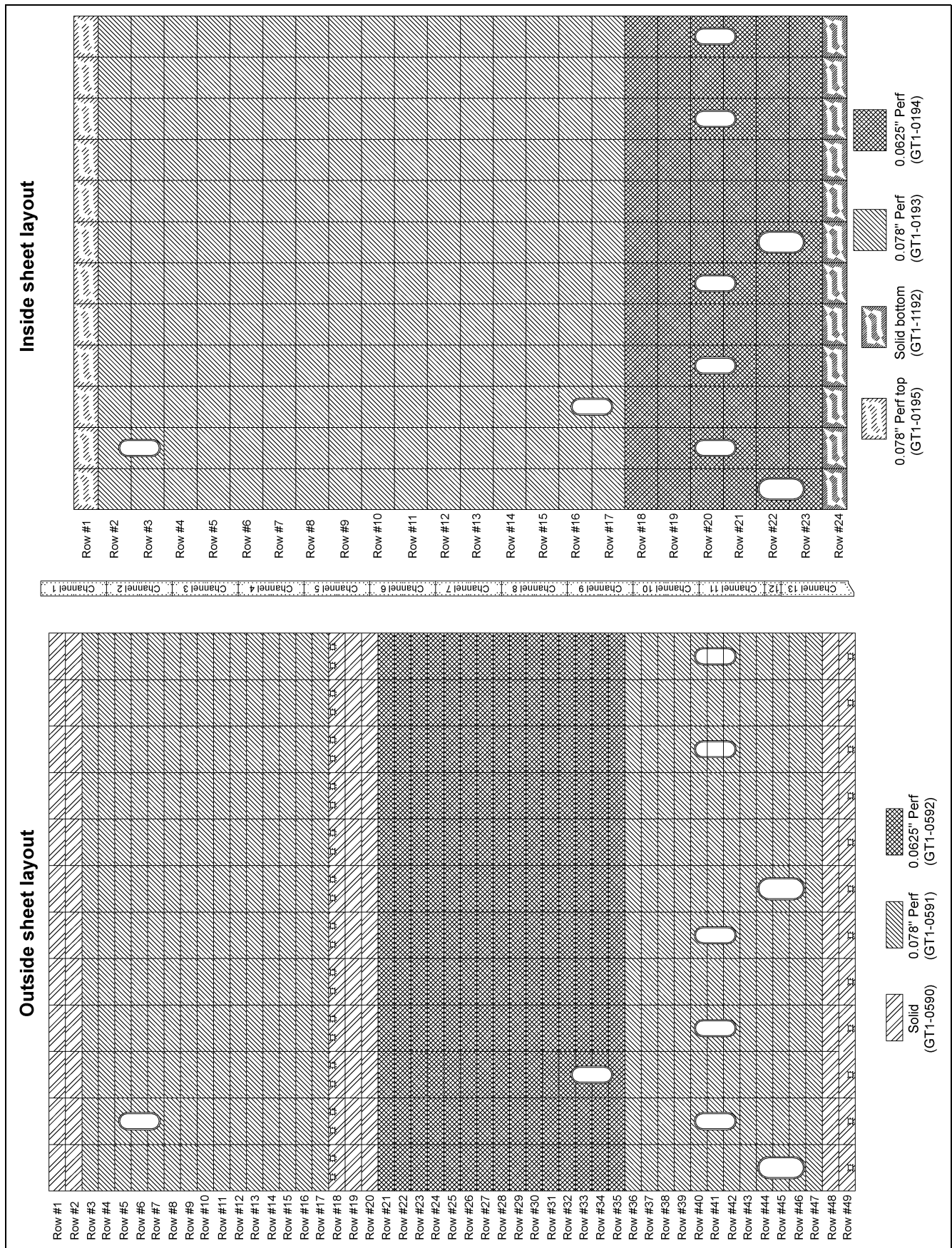

Figure 26AM Z-4036 Sheet Layout

26. All Tower Dryer Models Drawings

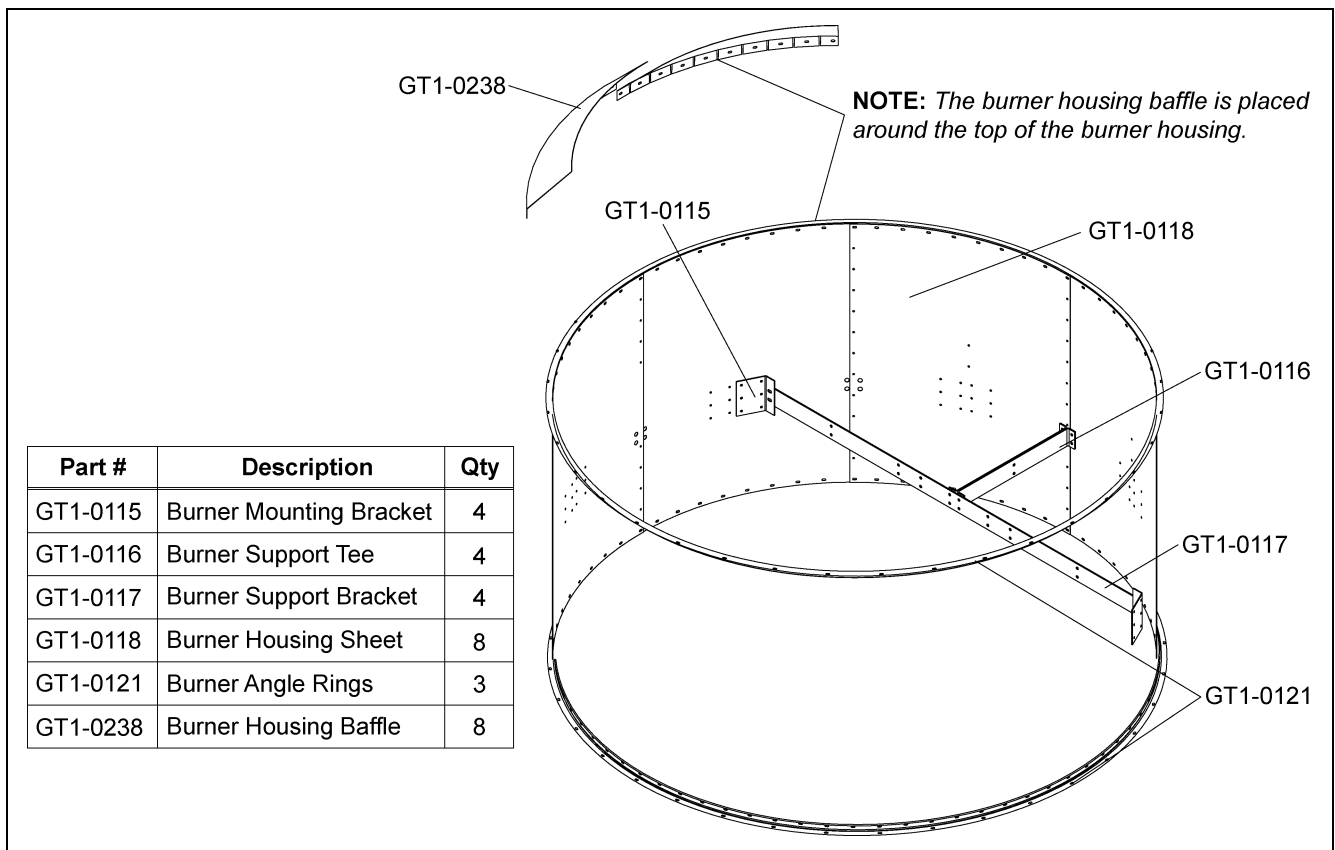

Figure 26AN Model 4000 Burner Housing Layout

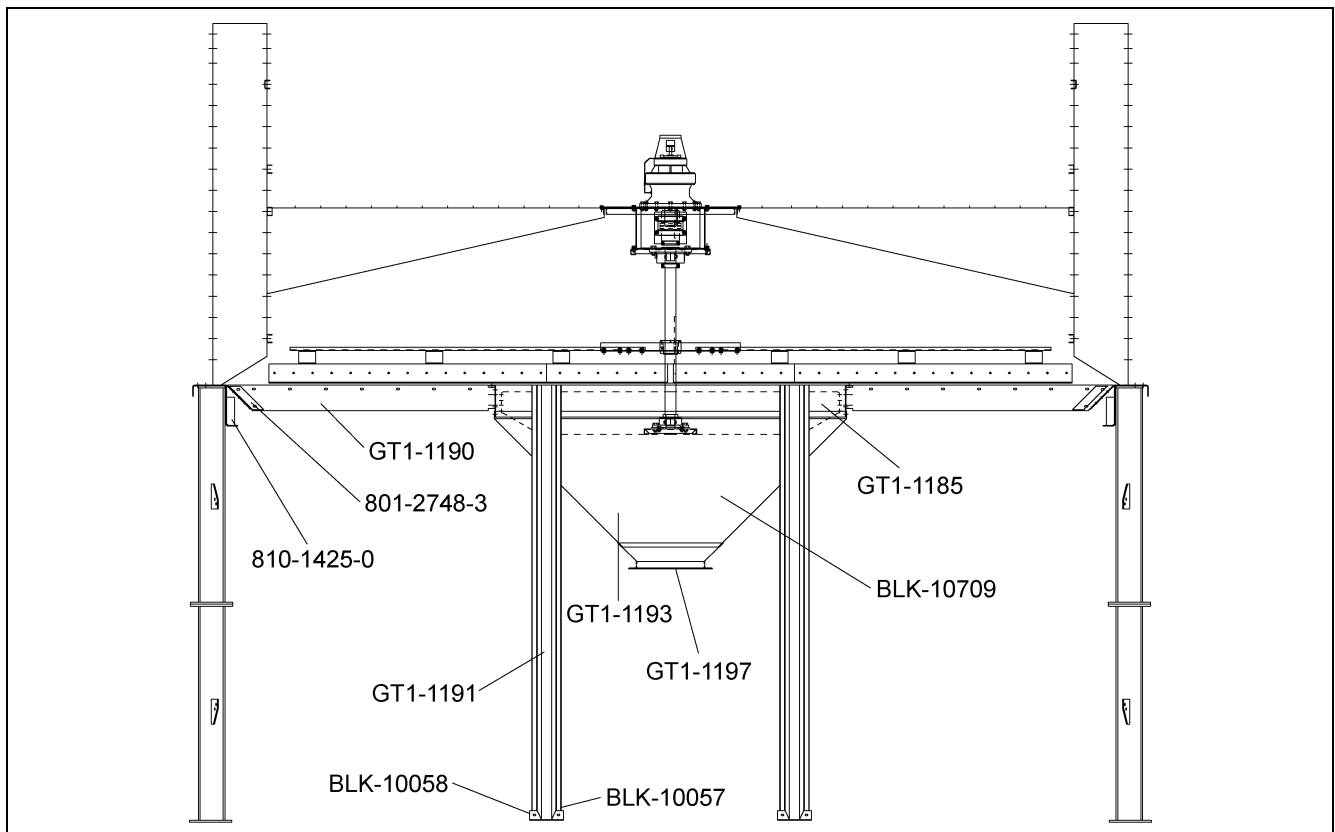

Figure 26AO

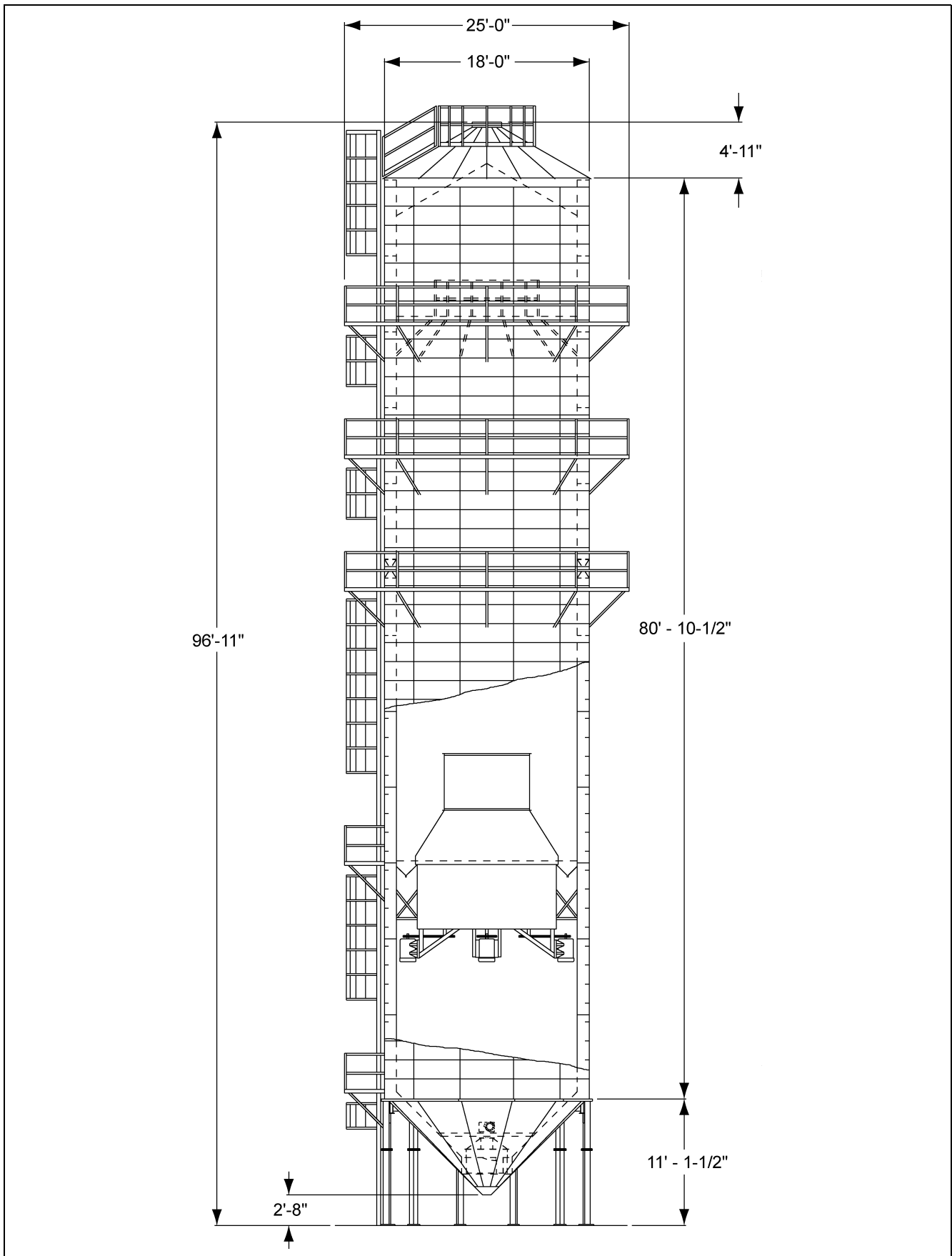

Figure 26AP GSI Tower Dryer Model 4000

26. All Tower Dryer Models Drawings

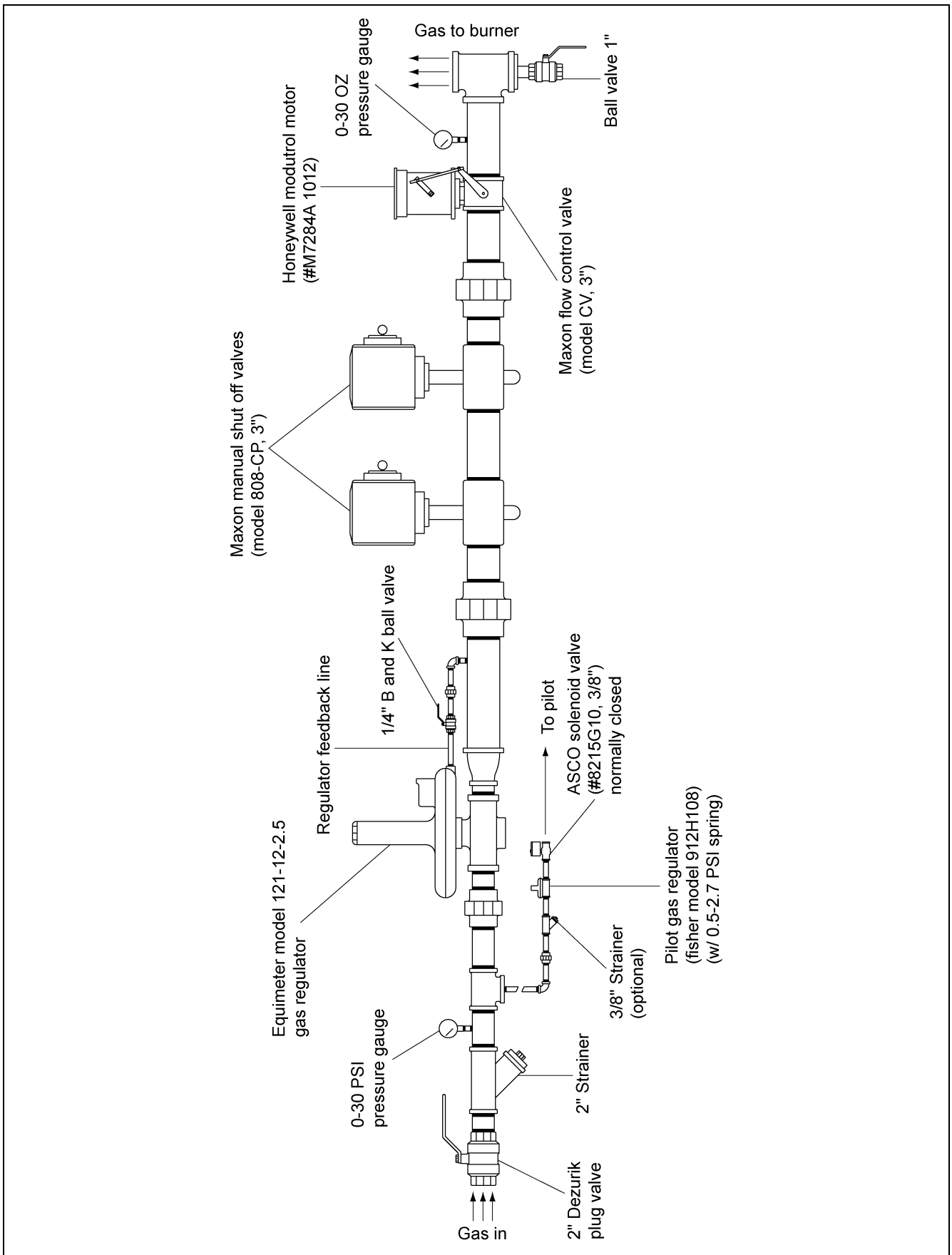

Figure 26AQ Tower Dryer 3" Gas Train

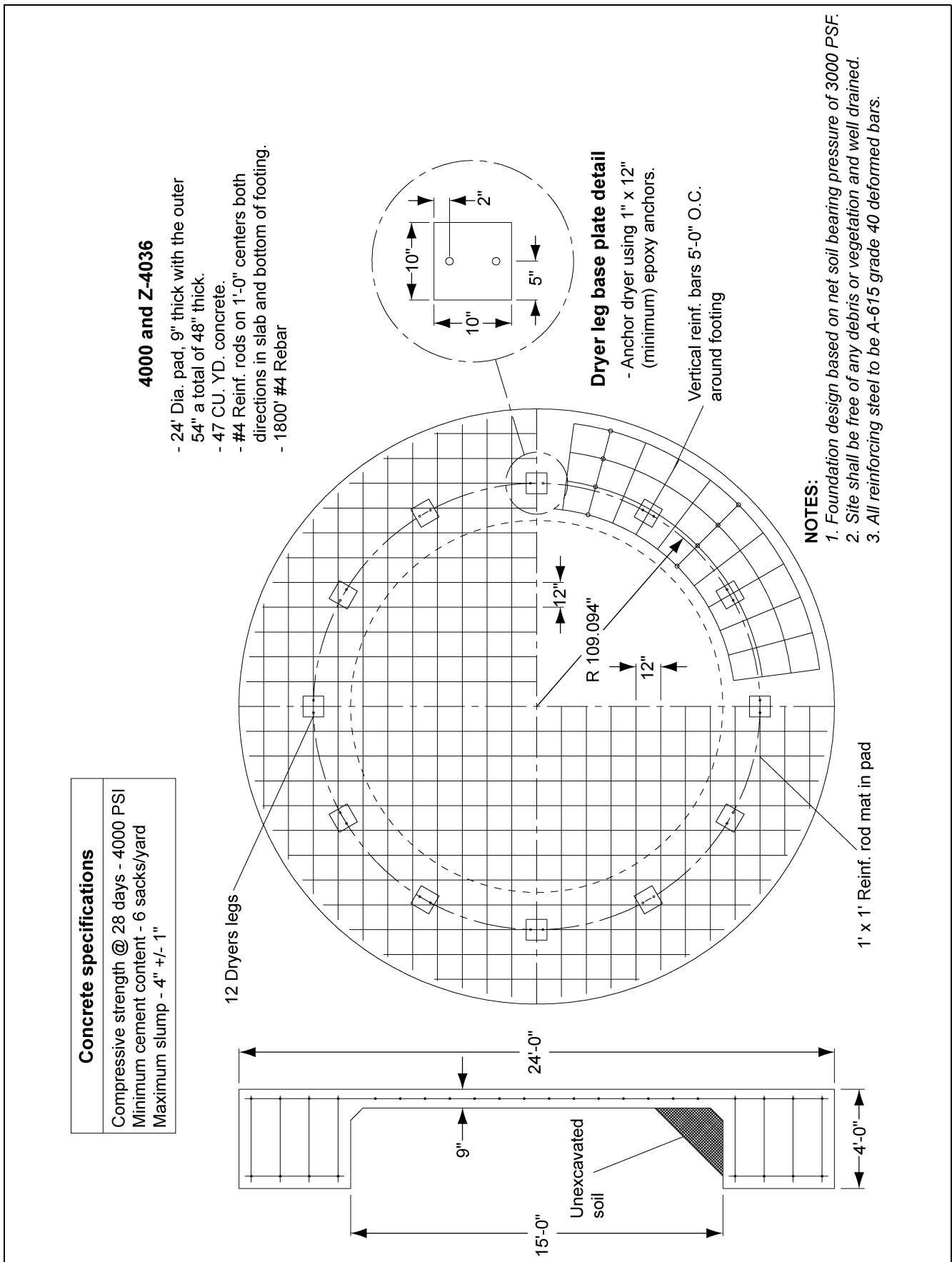
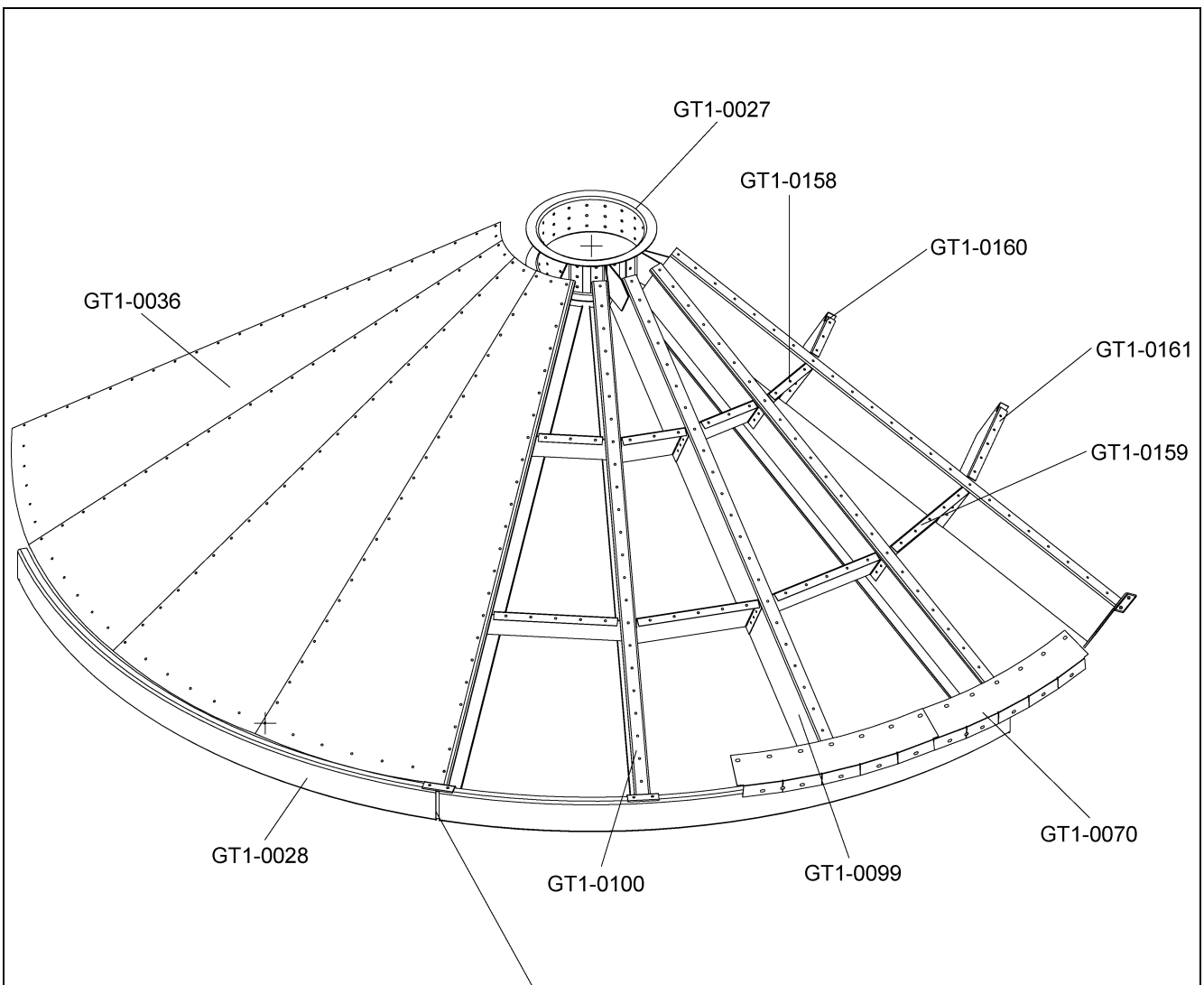

Figure 26AR Foundation Plan 4000 and Z-4036

26. All Tower Dryer Models Drawings



NOTE: Plenum eave splice GT1-0033 is not visible.

Part #	Description	Qty
GT1-0027	Plenum Rafter Collar 18'	1
GT1-0028	Plenum Eave Channel 18'	6
GT1-0033	Plenum Eave Splice 18'	6
GT1-0036	Plenum Roof Sheet 18'	18
GT1-0070	Plenum Roof Flashing 18'	18
GT1-0099	Rafter Weldment "A" 18'	9
GT1-0100	Rafter Weldment "B" 18'	9
GT1-0158	Rafter Short Top Crossmember 18'	9
GT1-0159	Rafter Short Bottom Crossmember 18'	9
GT1-0160	Rafter Long Top Crossmember 18'	9
GT1-0161	Rafter Long Bottom Crossmember 18'	9

Figure 26AS Plenum Roof Assembly 18'

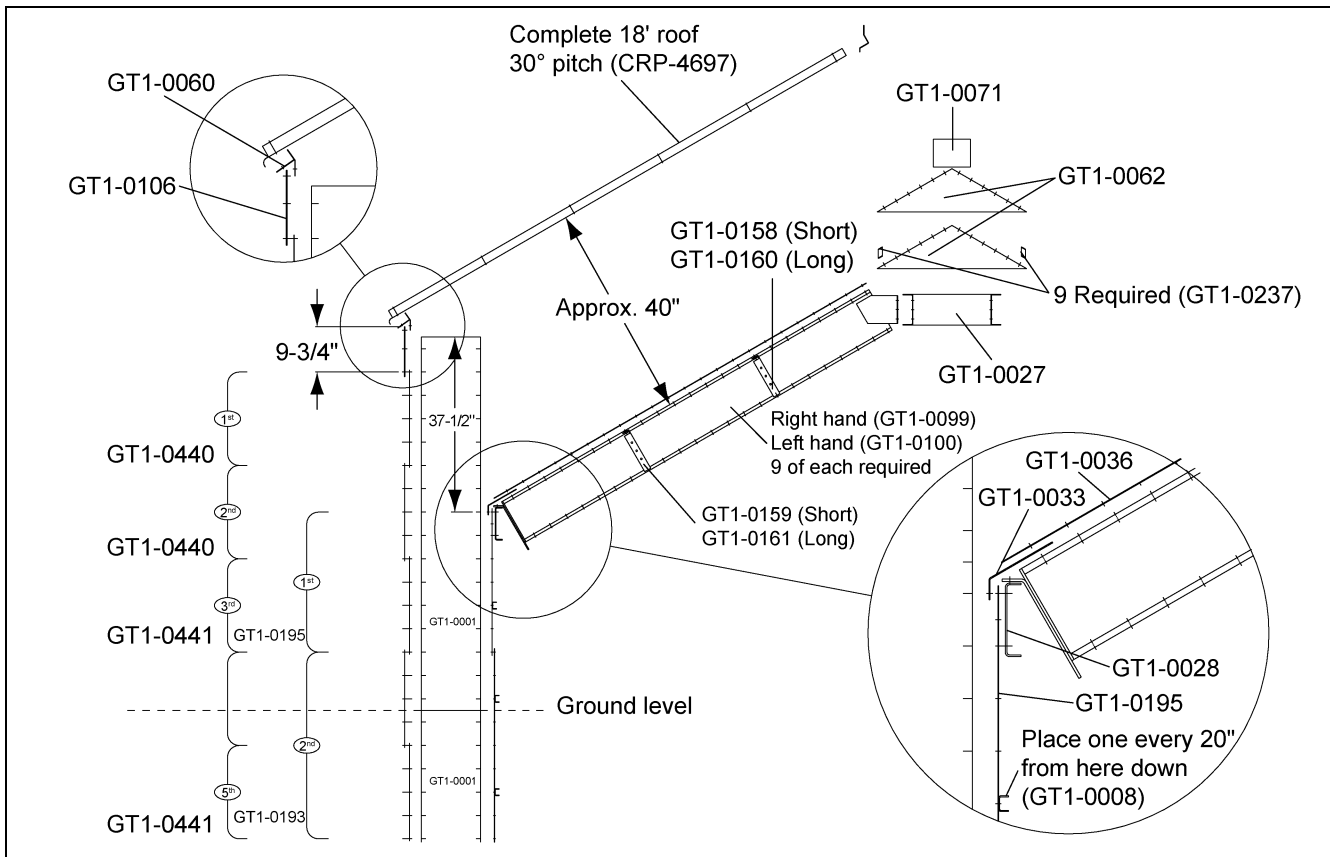

Figure 26AT Plenum Roof Detail 18'

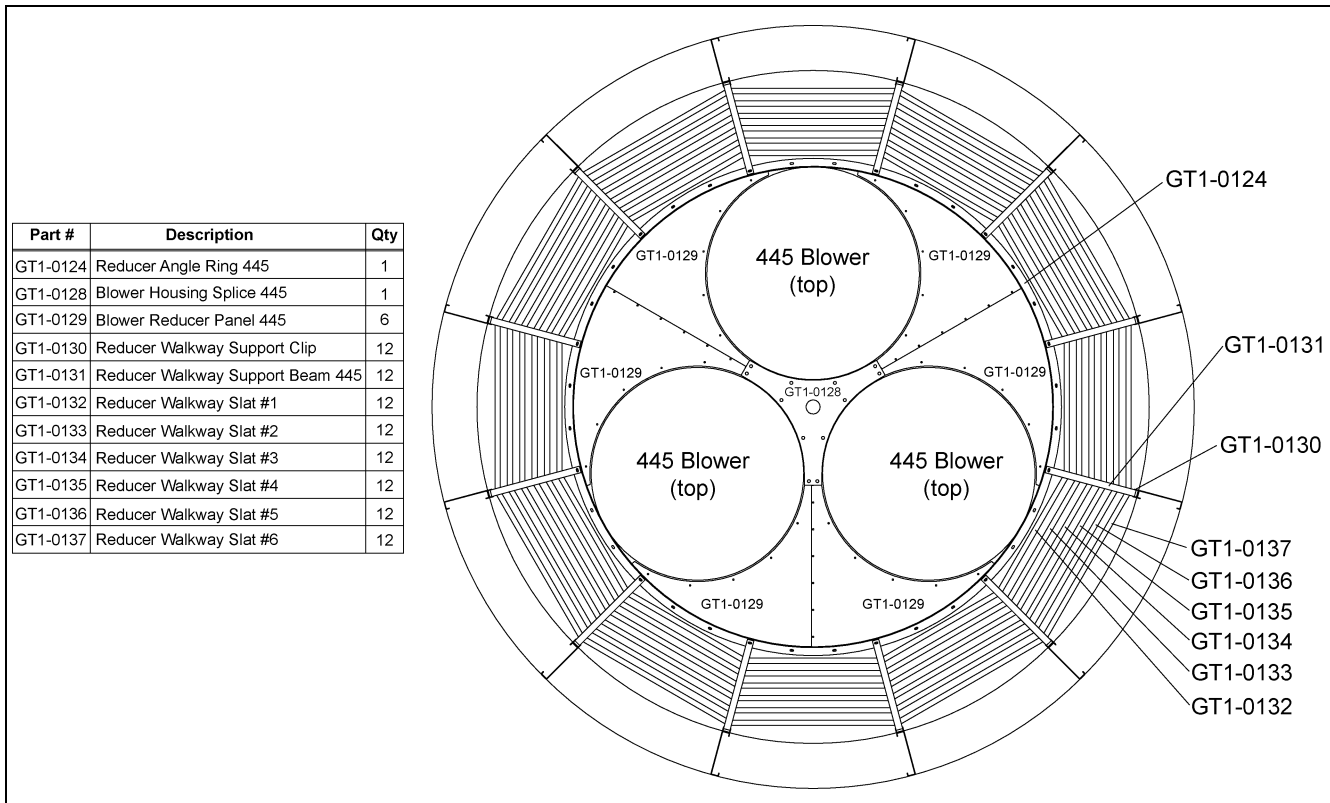
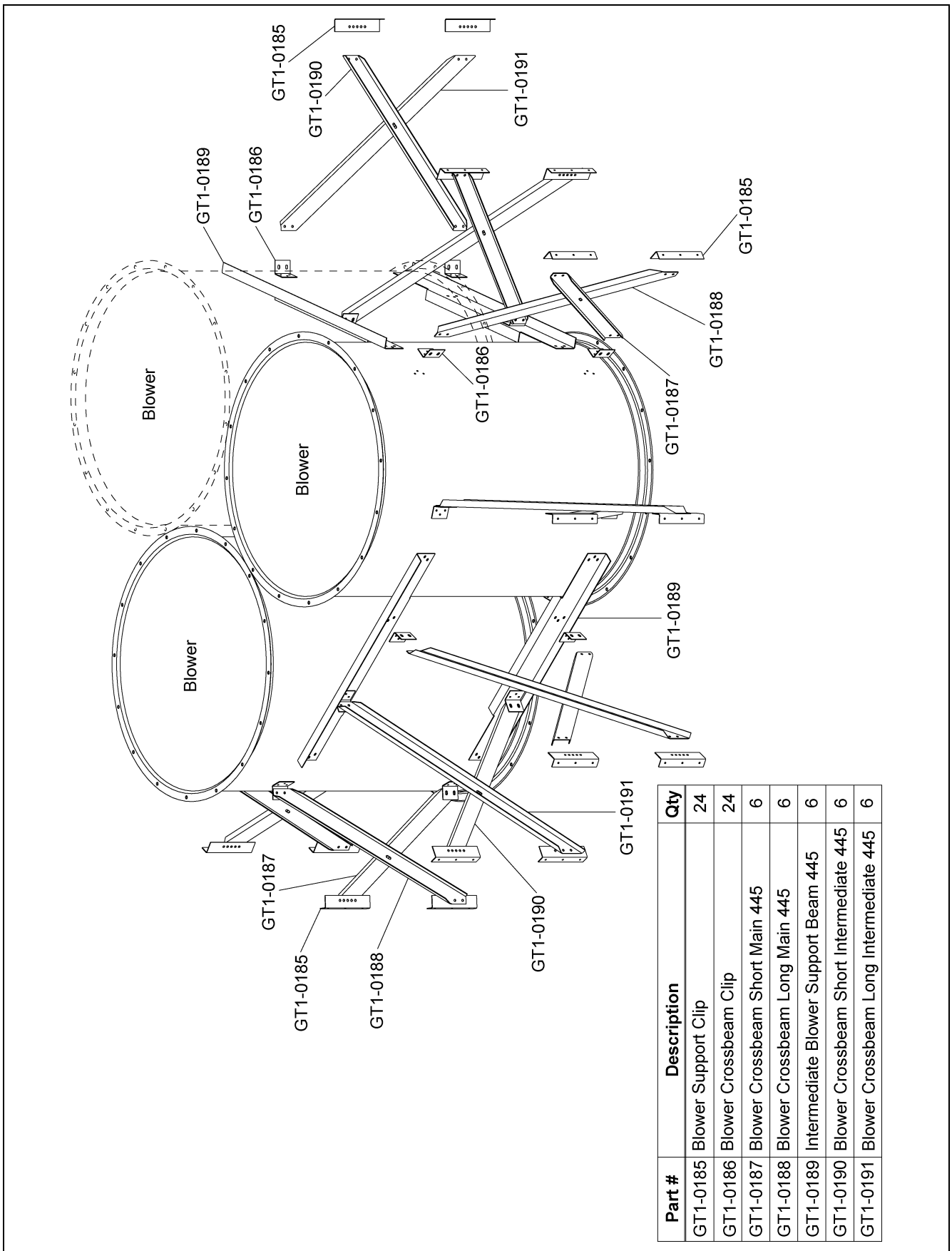

Figure 26AU Reducer Walkway and Blower Top 445

26. All Tower Dryer Models Drawings



Part #	Description	Qty
GT1-0185	Blower Support Clip	24
GT1-0186	Blower Crossbeam Clip	24
GT1-0187	Blower Crossbeam Short Main 445	6
GT1-0188	Blower Crossbeam Long Main 445	6
GT1-0189	Intermediate Blower Support Beam 445	6
GT1-0190	Blower Crossbeam Short Intermediate 445	6
GT1-0191	Blower Crossbeam Long Intermediate 445	6

Figure 26AV 18' Blower Cluster Assembly

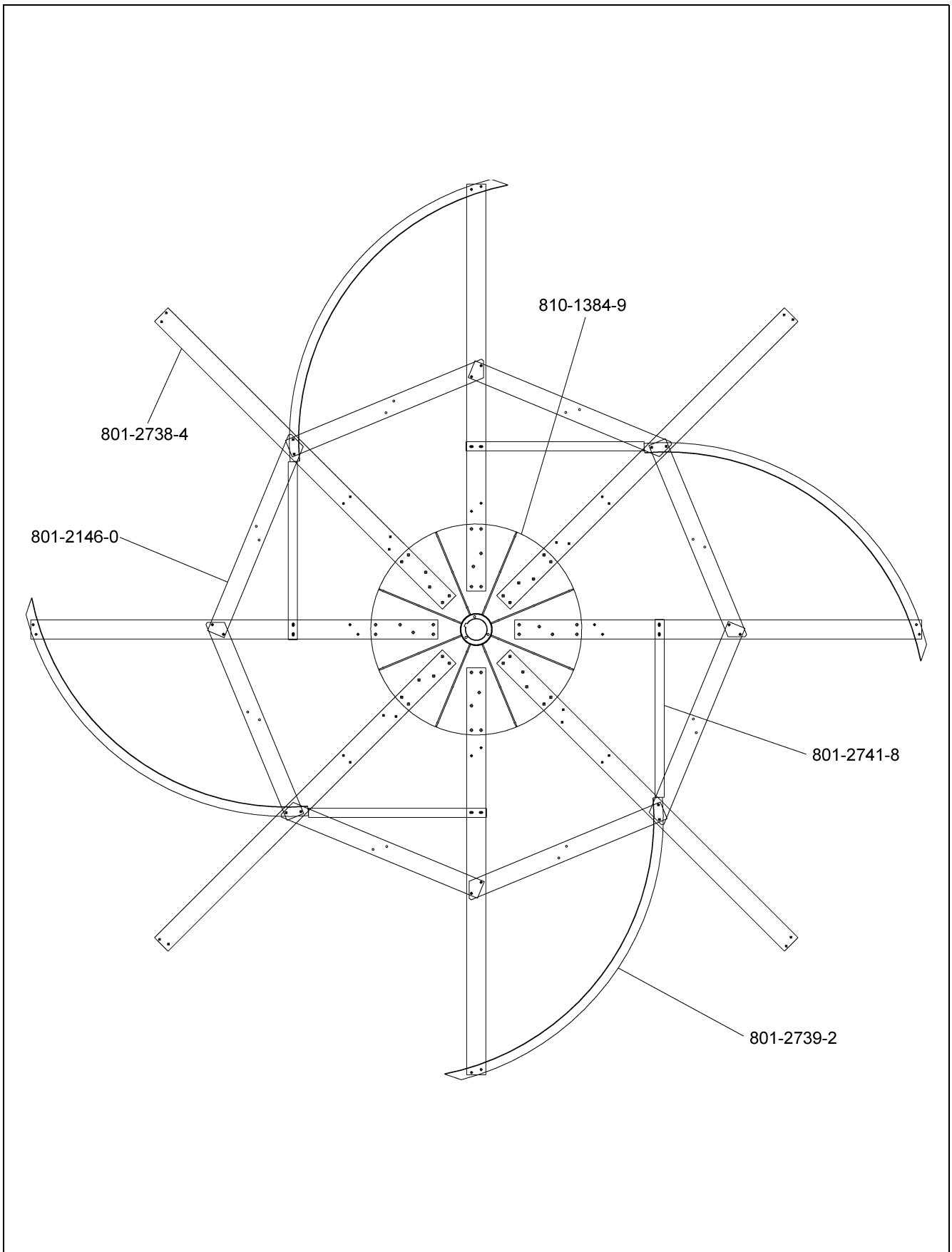

Figure 26AW Zimmerman 18' Sweep Arrangement

26. All Tower Dryer Models Drawings

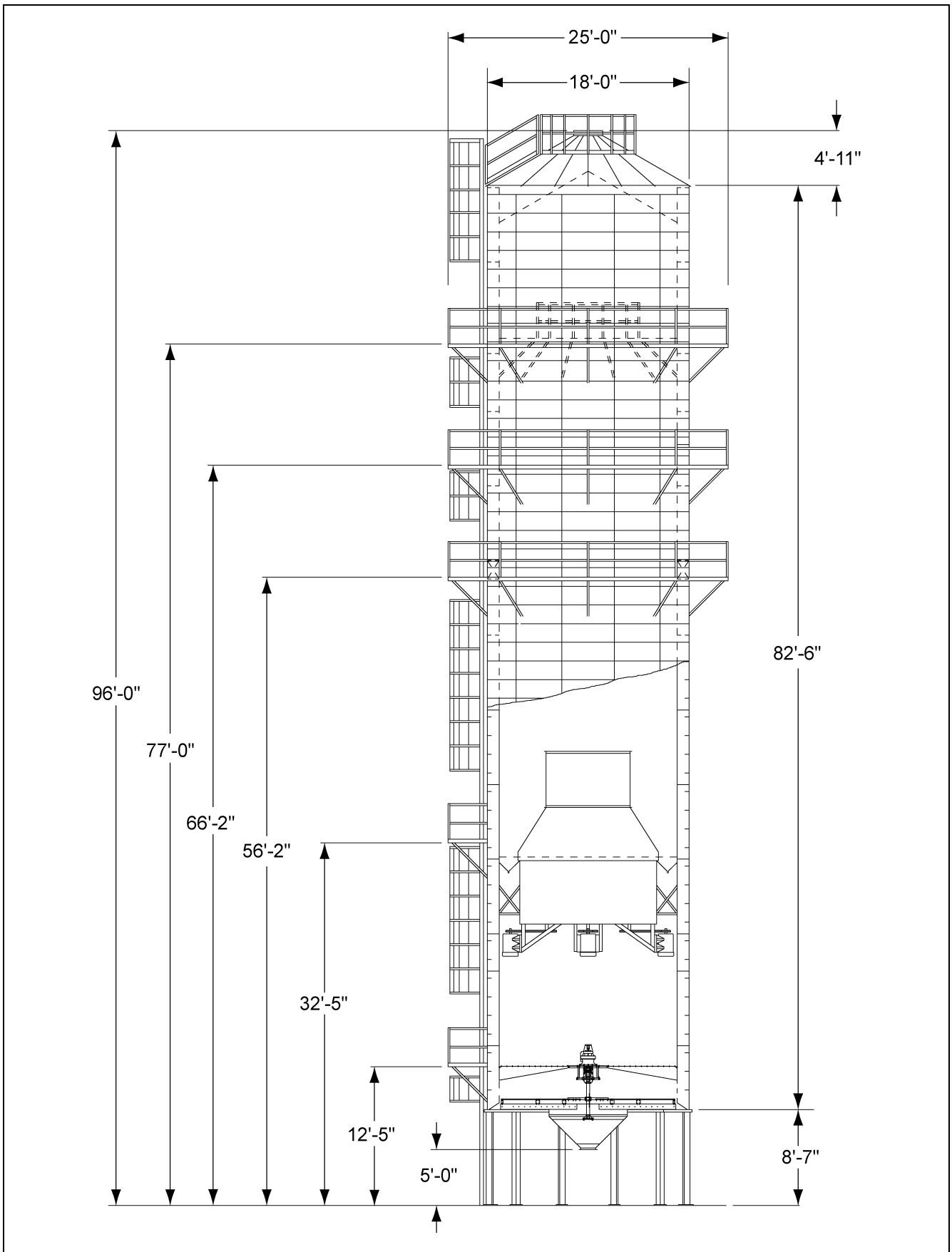

Figure 26AX Zimmerman Tower Dryer Model Z-4036

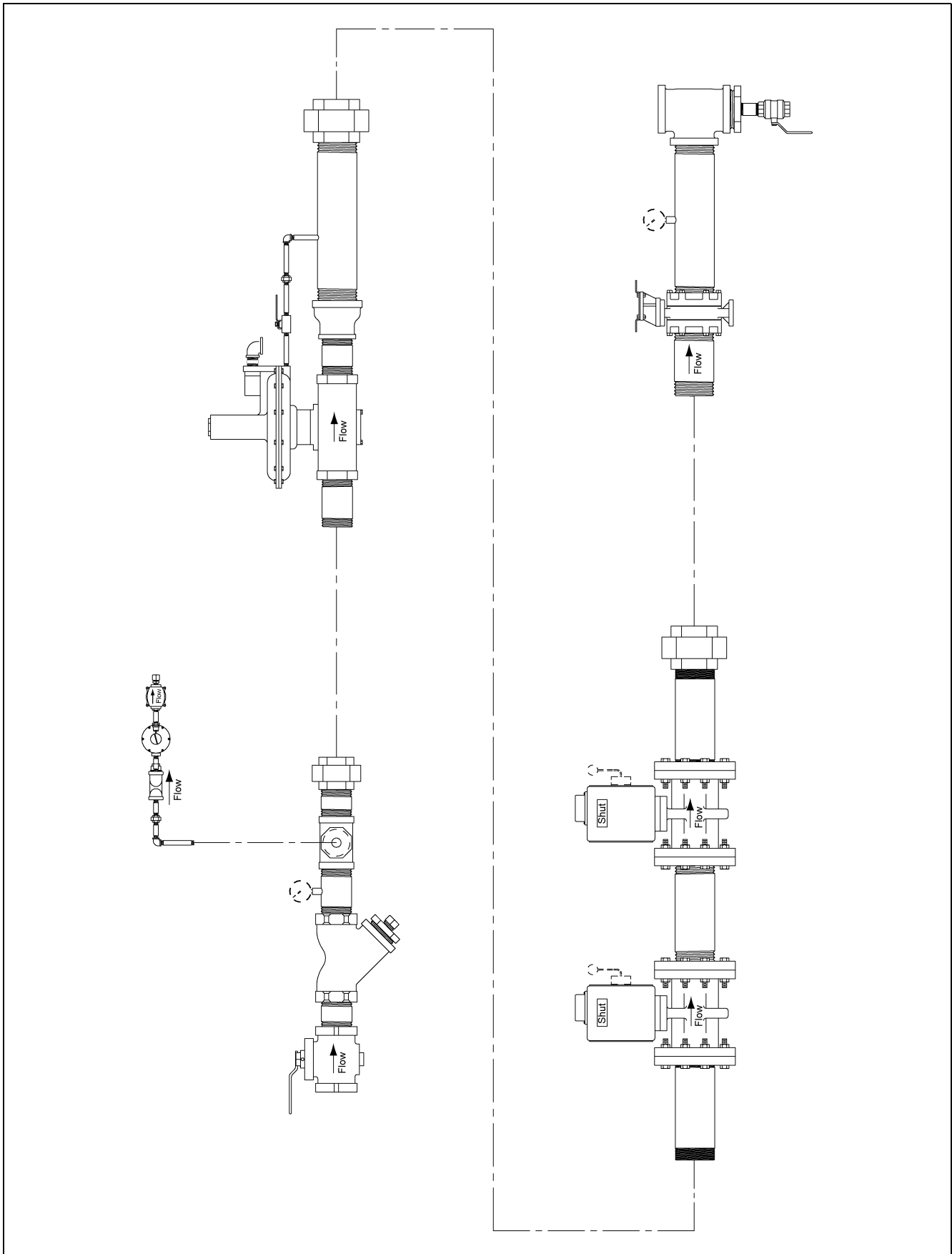

Figure 26AY Complete 4" Gas Train - Domestic

26. All Tower Dryer Models Drawings

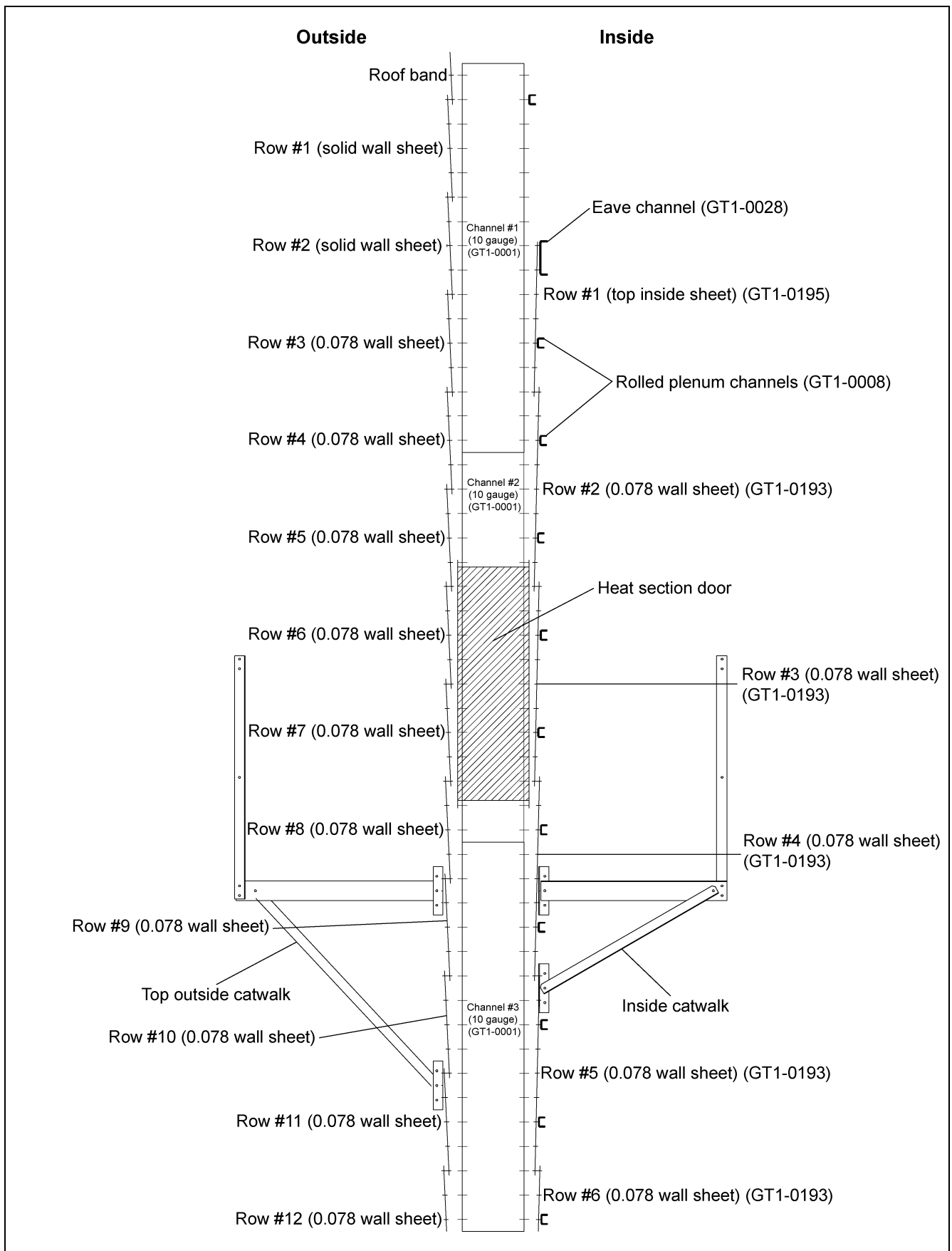

Figure 26AZ Clip Placement Z-4742/G-4718 Channels 1 to 3

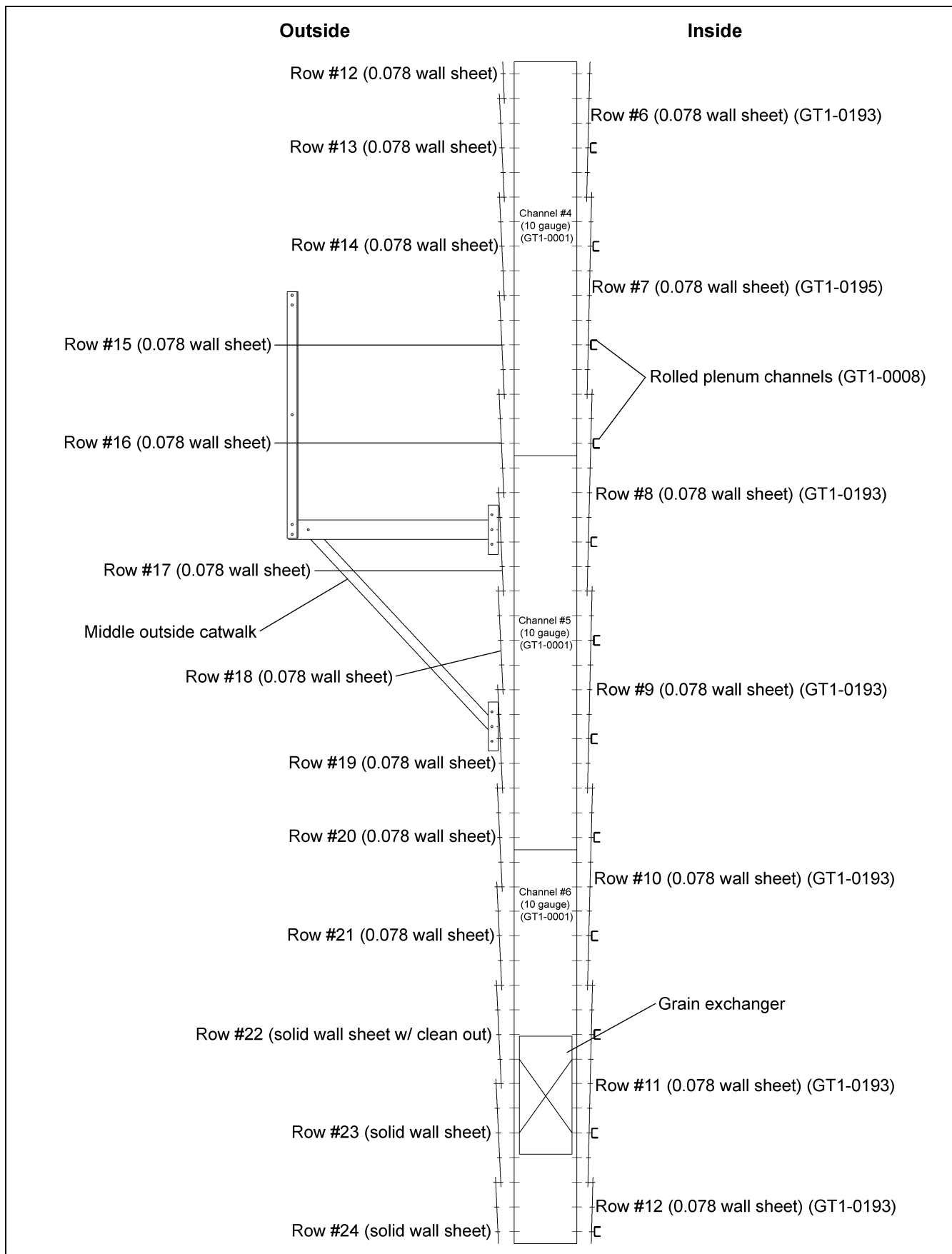

Figure 26BA Clip Placement Z-4742/G-4718 Channels 4 to 6

26. All Tower Dryer Models Drawings

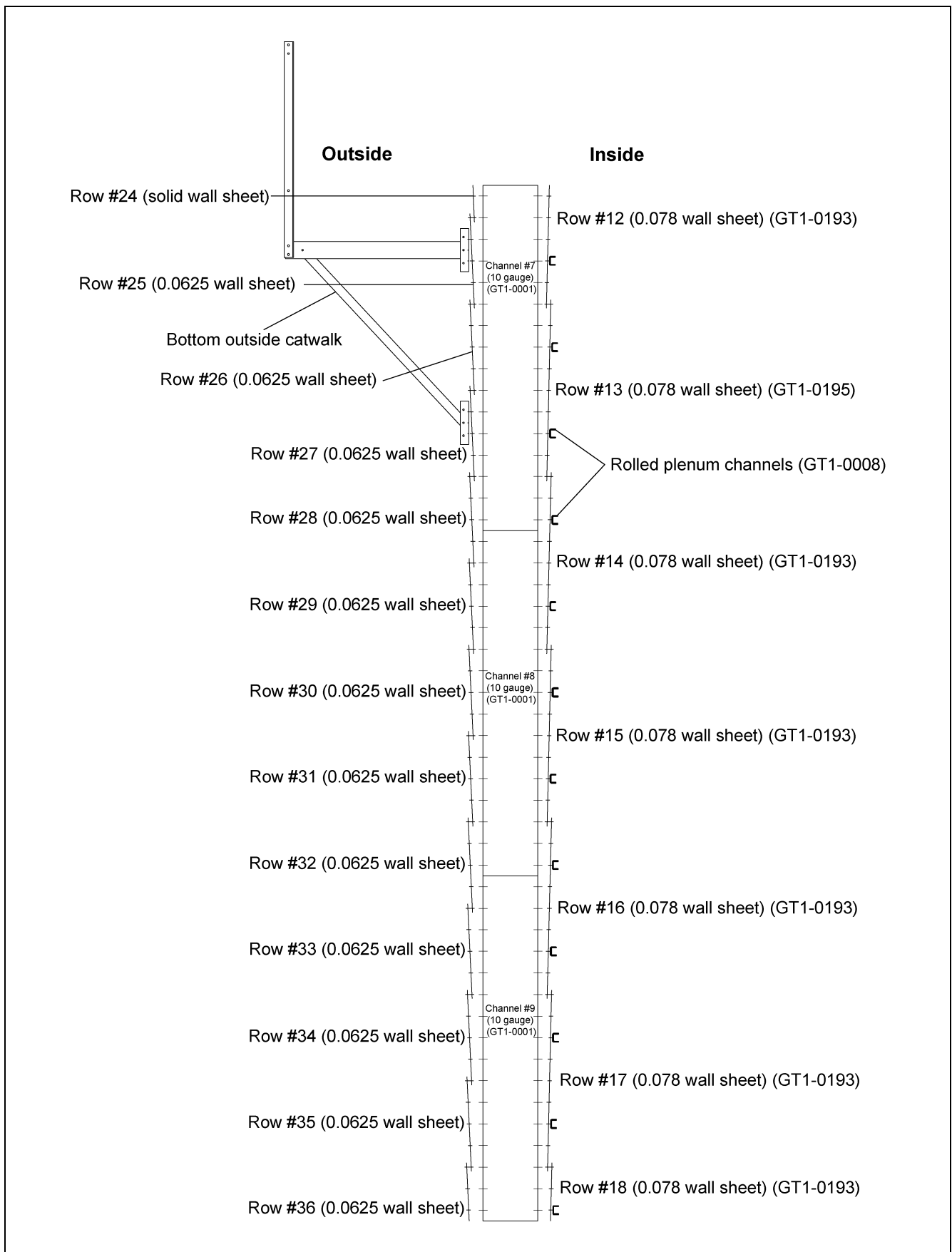

Figure 26BB Clip Placement Z-4742/G-4718 Channels 7 to 9

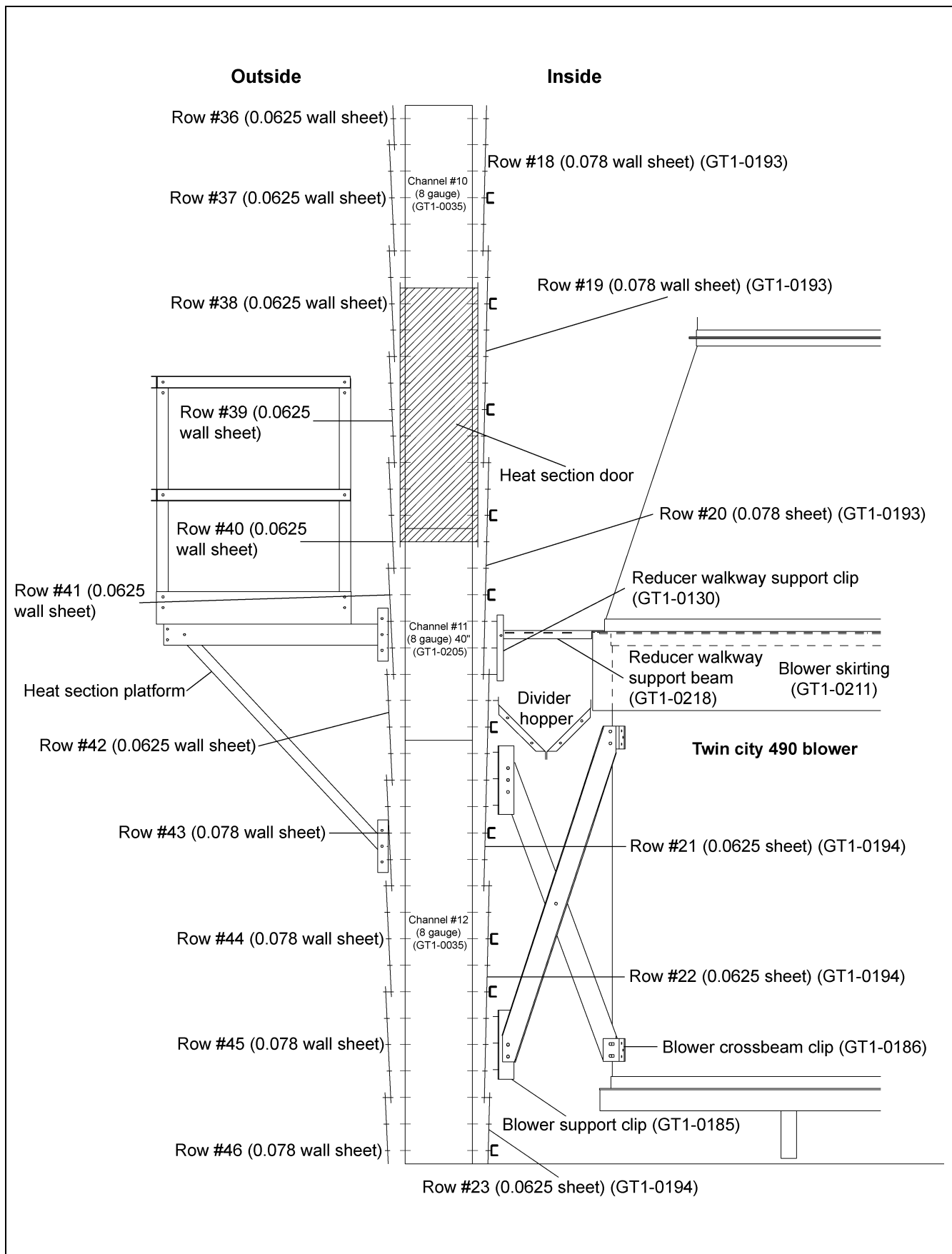

Figure 26BC Clip Placement G-4718 Channels 10 to 12

26. All Tower Dryer Models Drawings

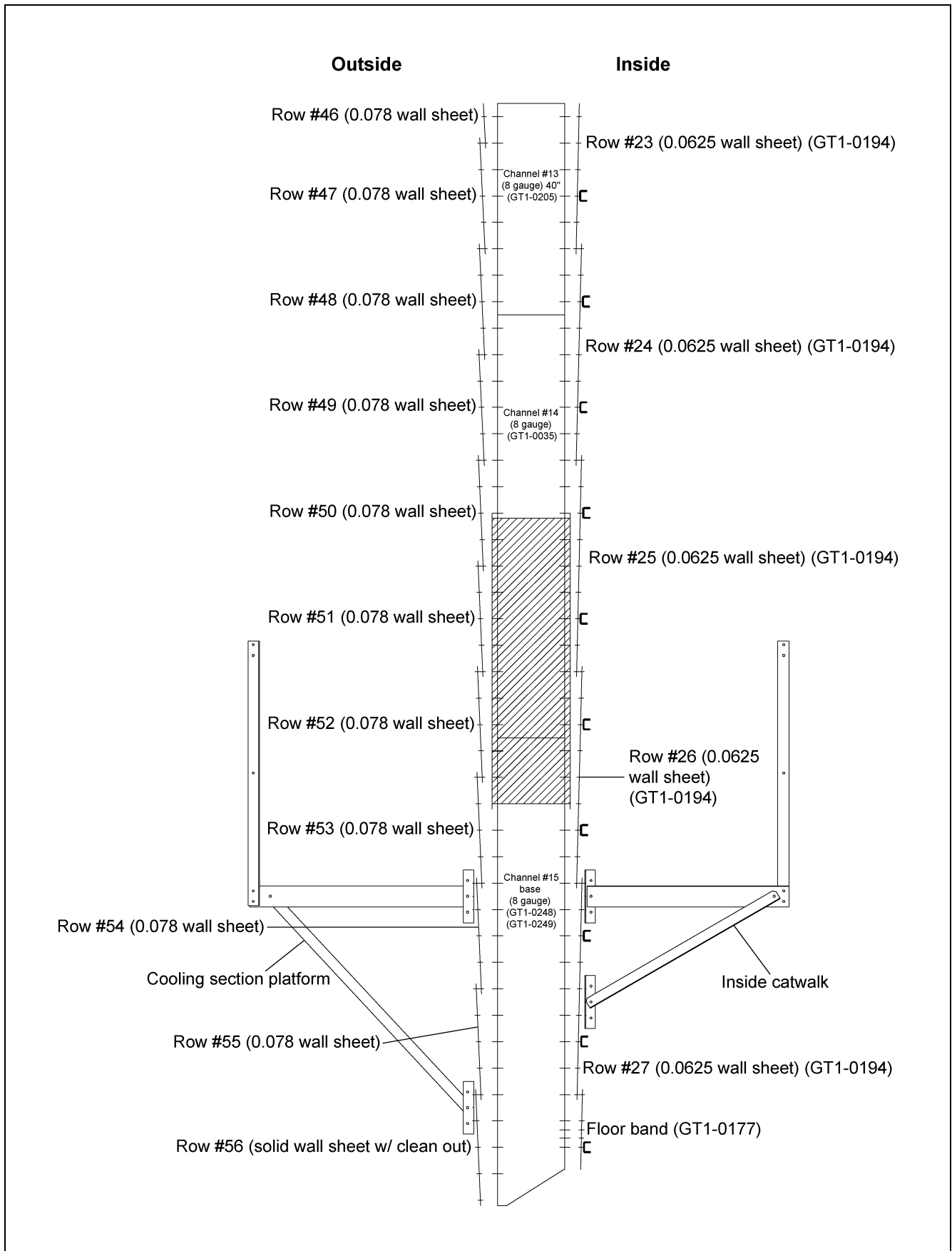

Figure 26BD Clip Placement G-4718 Channels 13 to 15

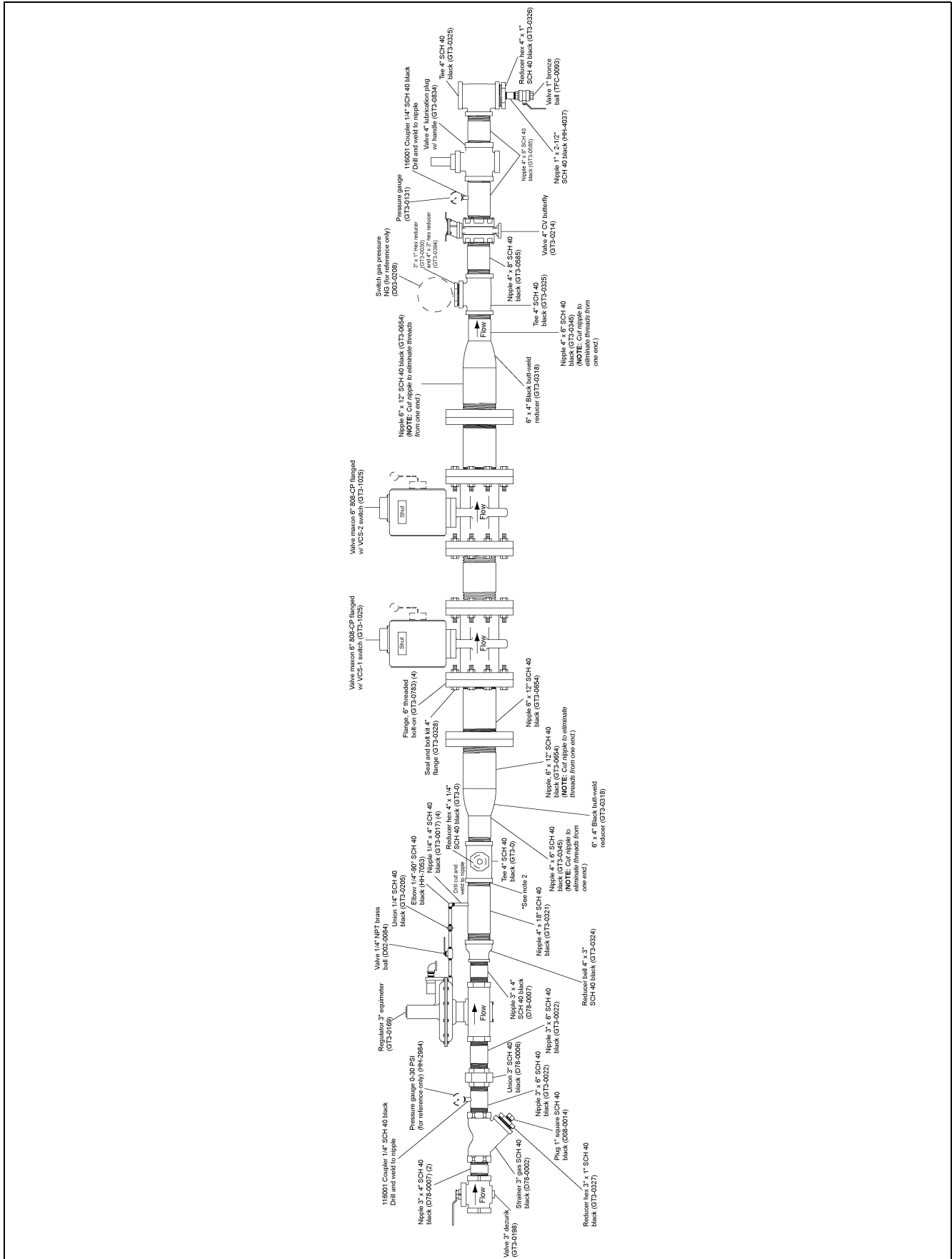

Figure 26BE 10000 BPH 6" Fuel Train

26. All Tower Dryer Models Drawings

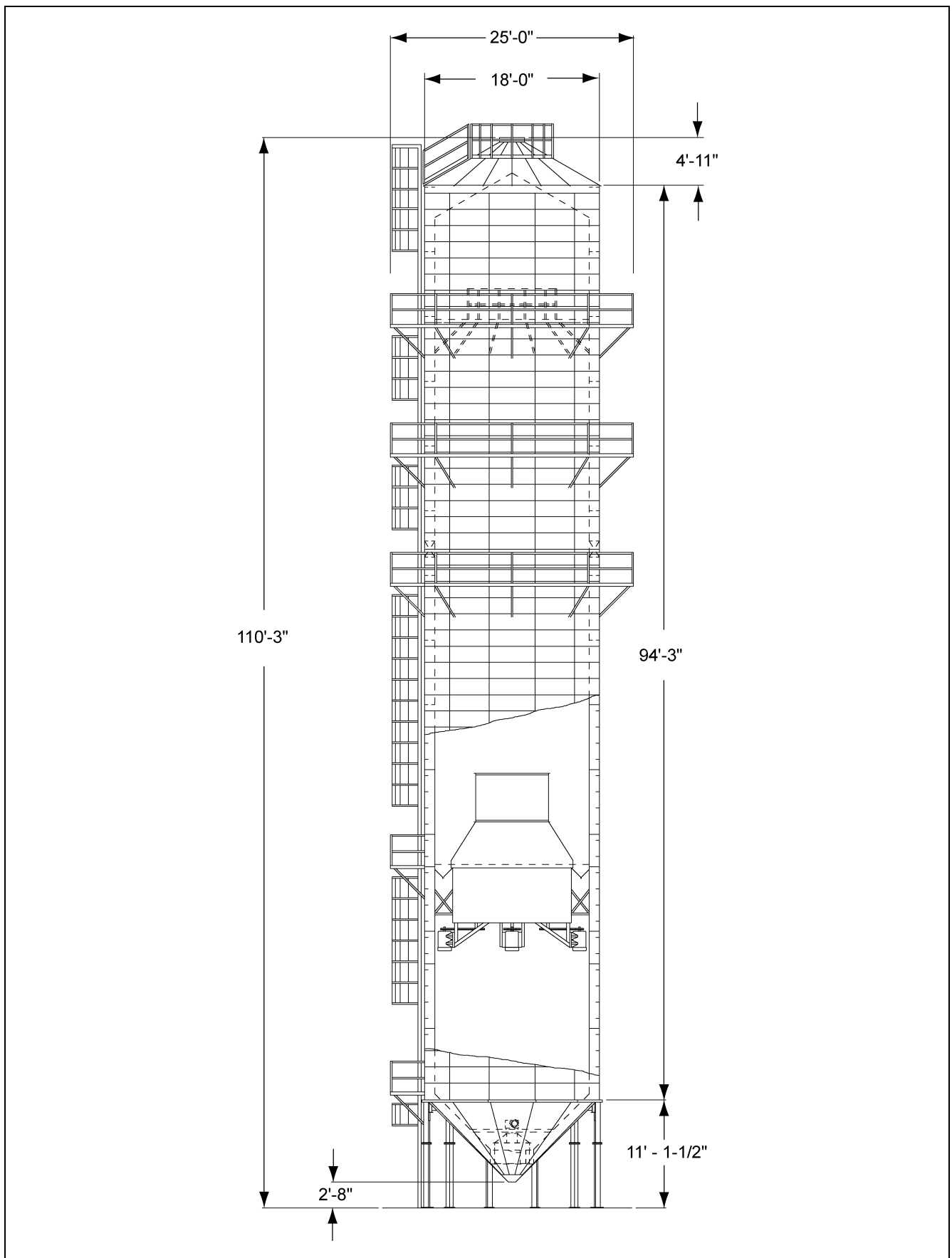

Figure 26BF GSI Tower Dryer Model 4718

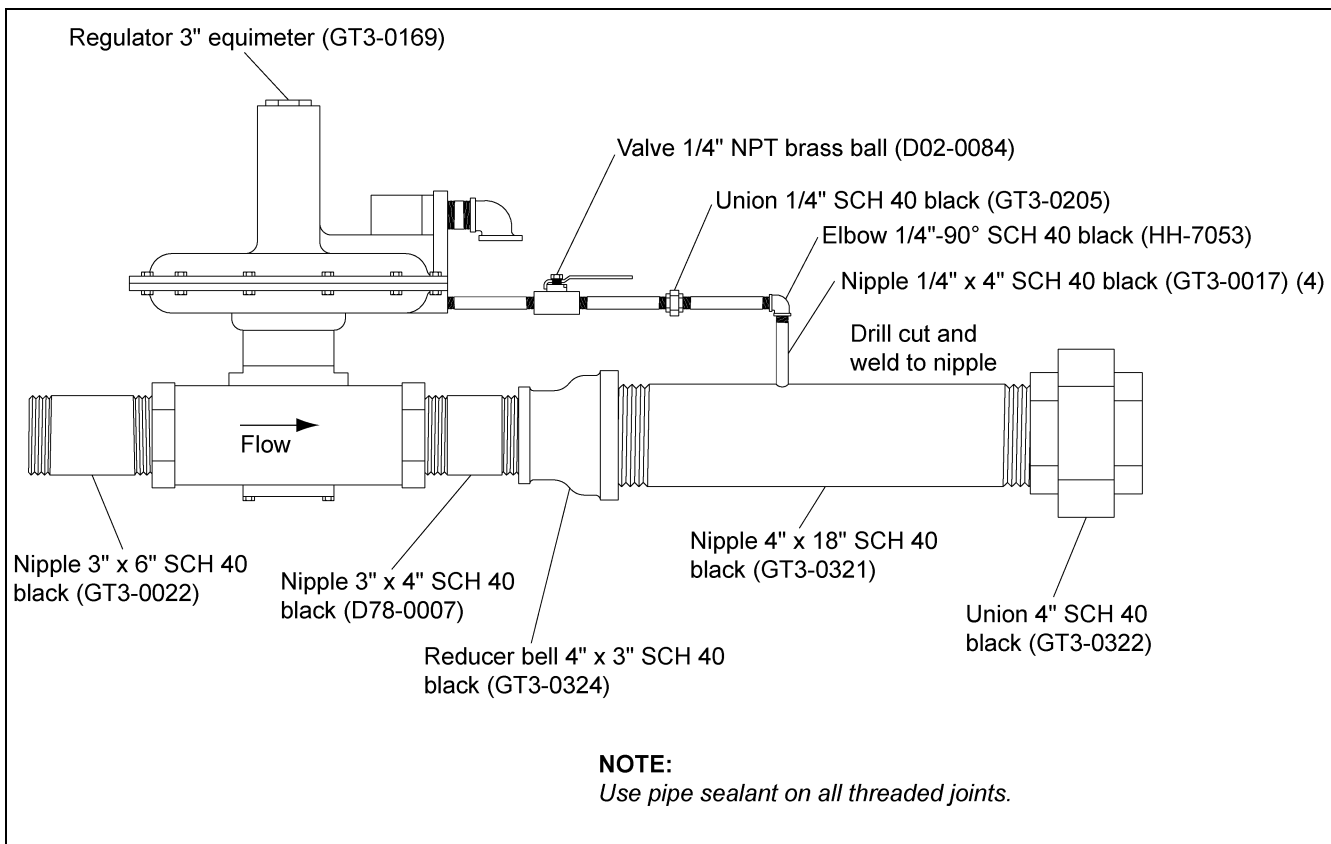

Figure 26BG 4" Regulator Section - Domestic

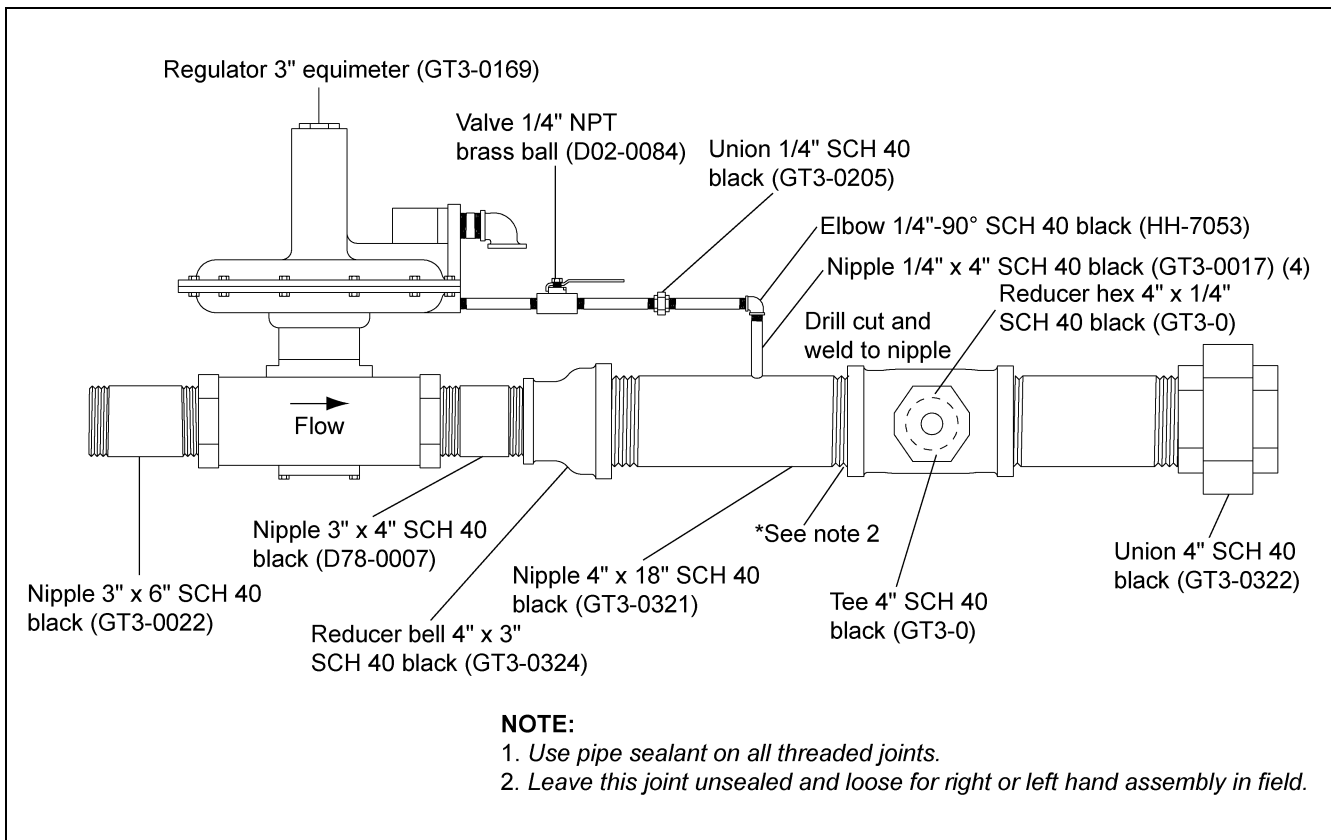

Figure 26BH 4" Regulator Section - Canadian

26. All Tower Dryer Models Drawings

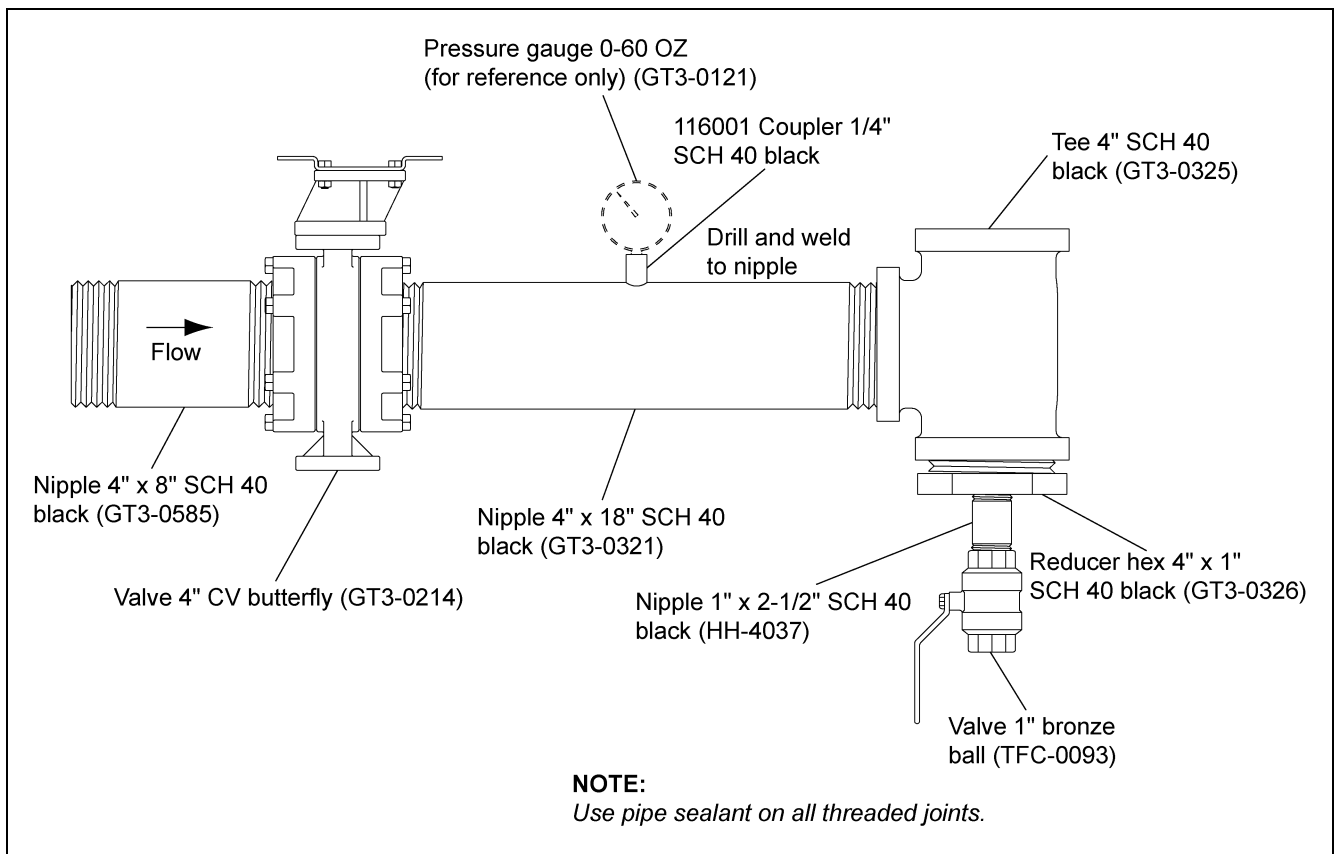

Figure 26BI 4" Modulator Section - Domestic

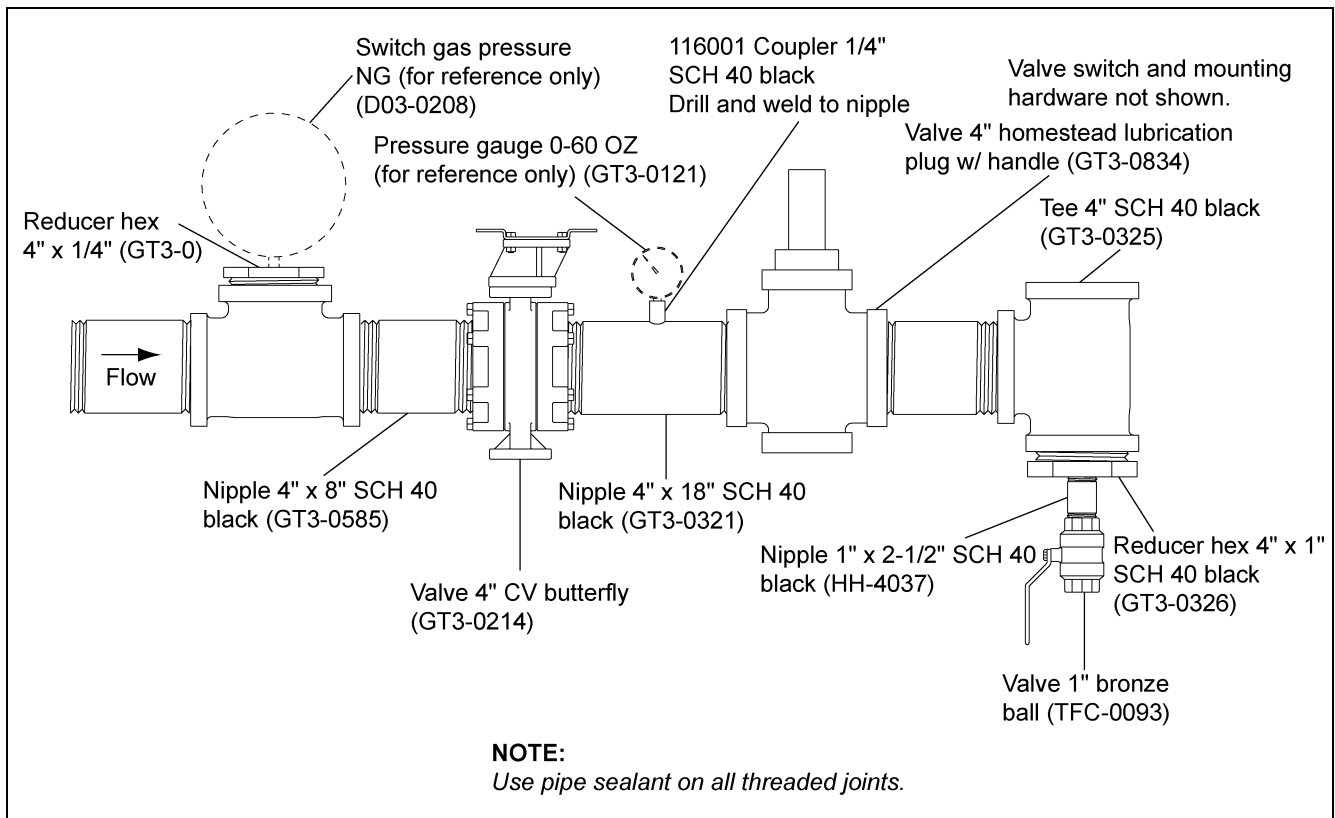

Figure 26BJ 4" Modulator Section - Canadian

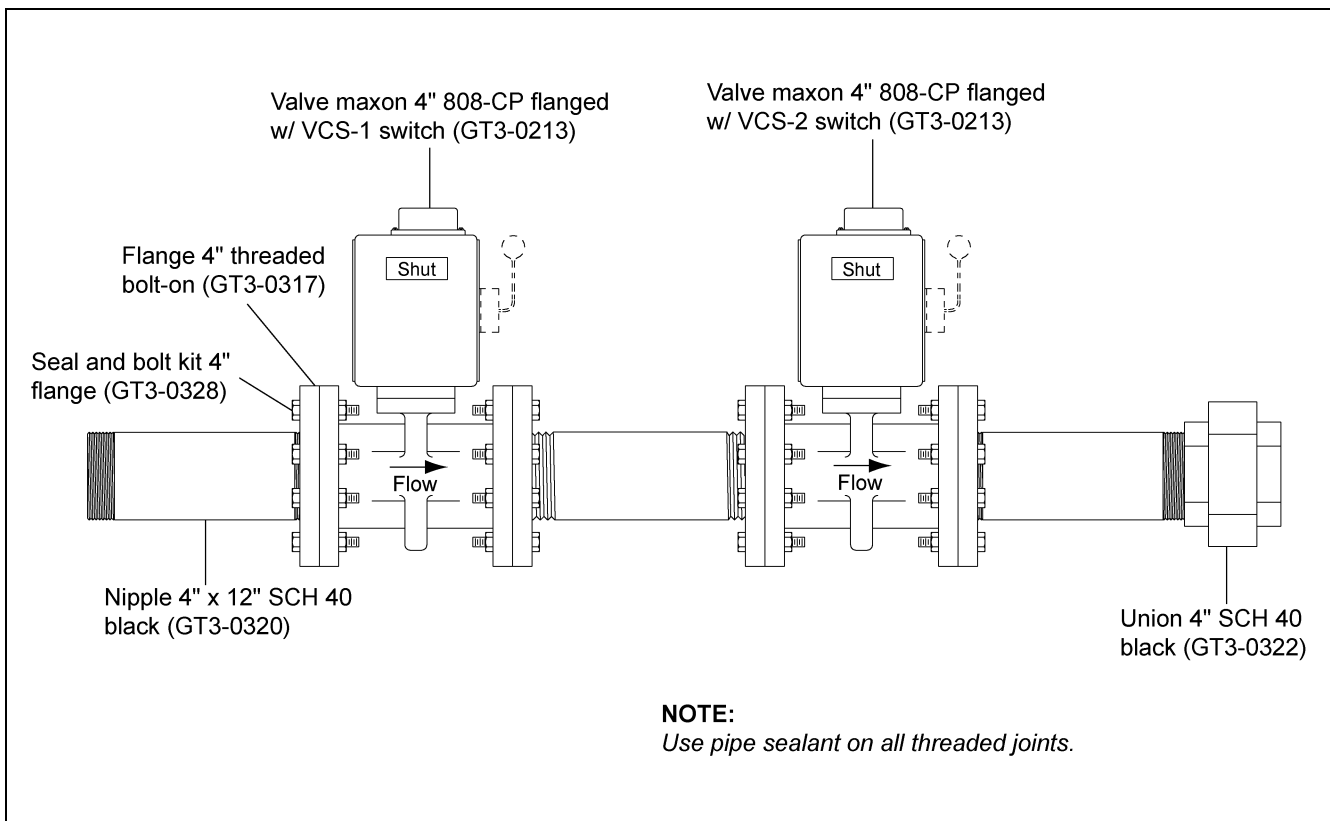

Figure 26BK 4" Maxon Section - Domestic

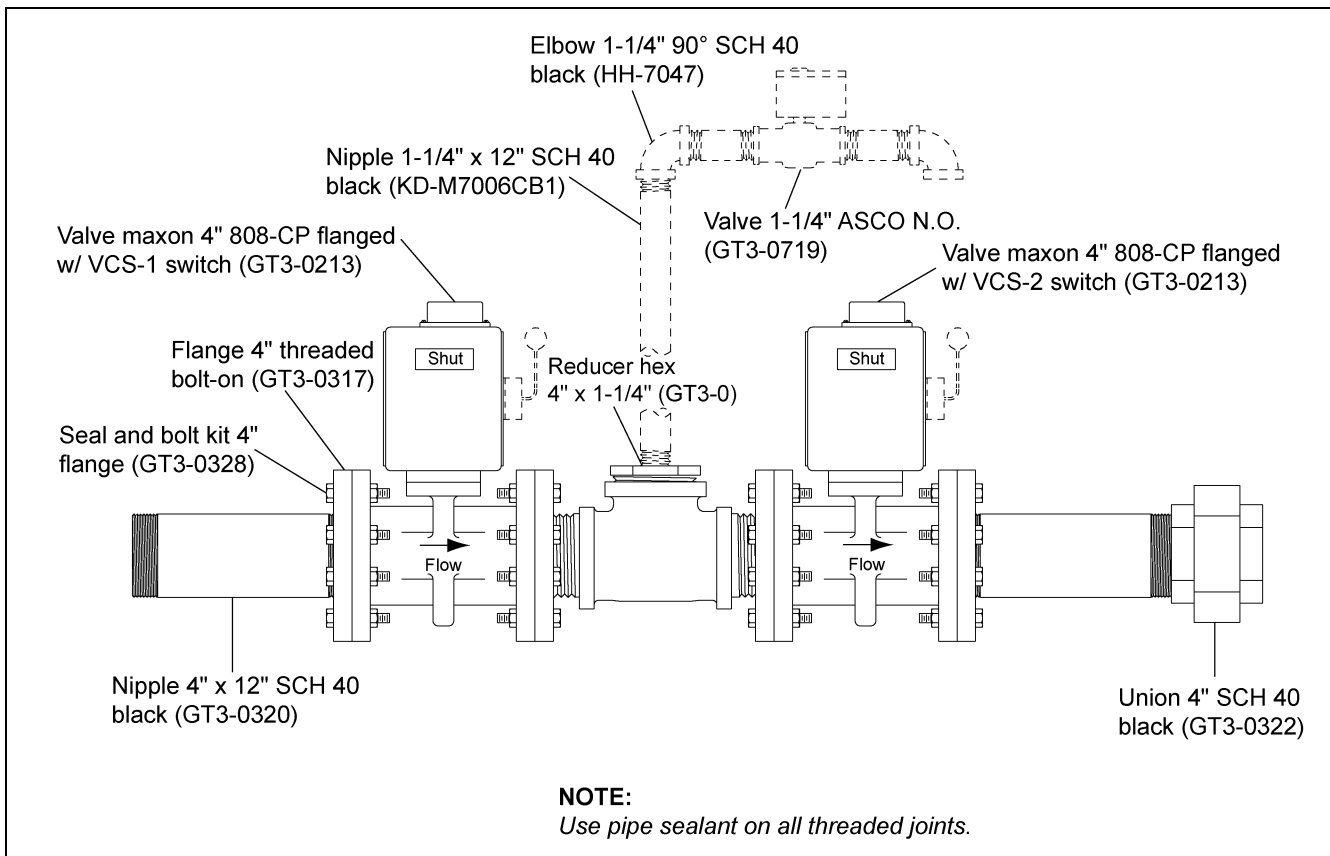

Figure 26BL 4" Maxon Section - Canadian

26. All Tower Dryer Models Drawings

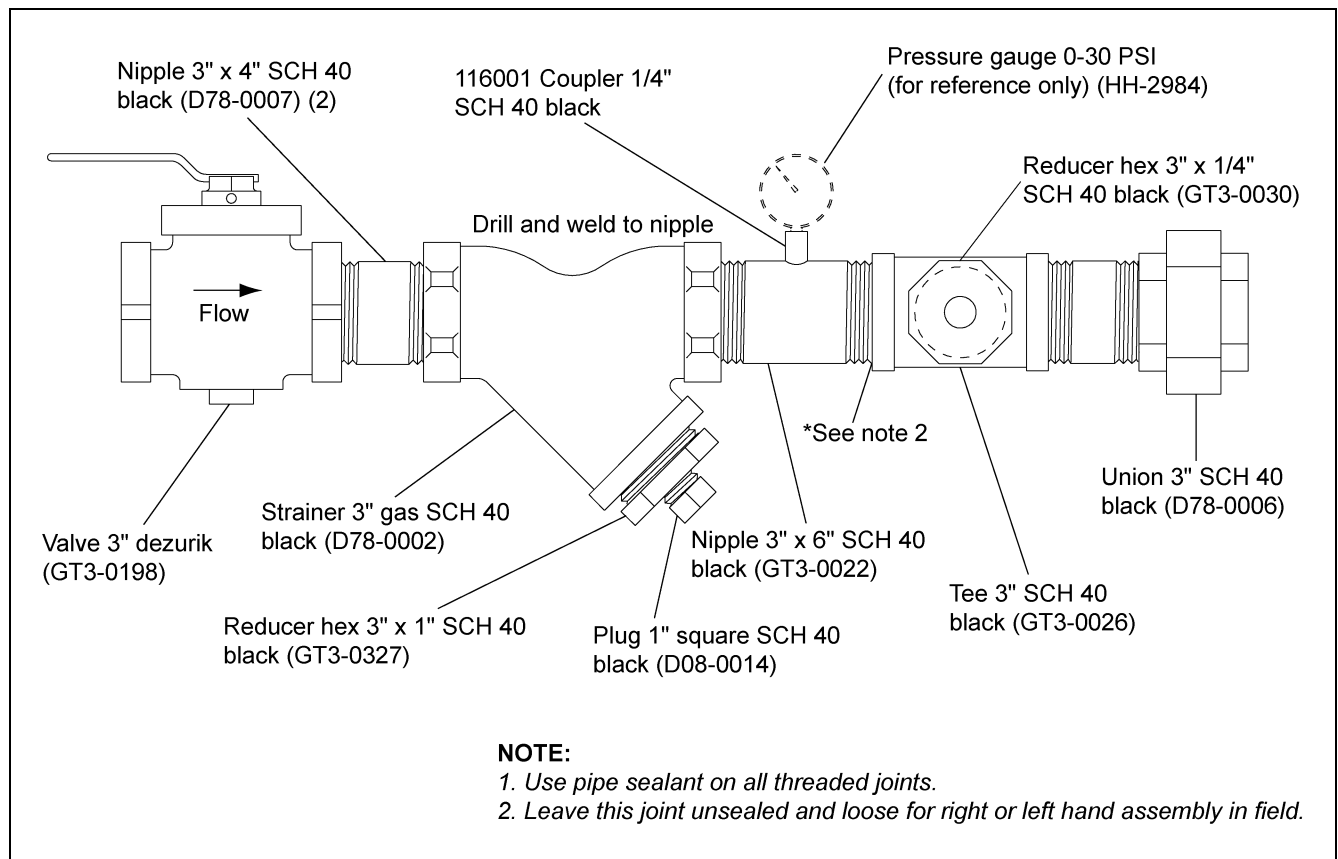

Figure 26BM 3" Shut Off Section - Domestic

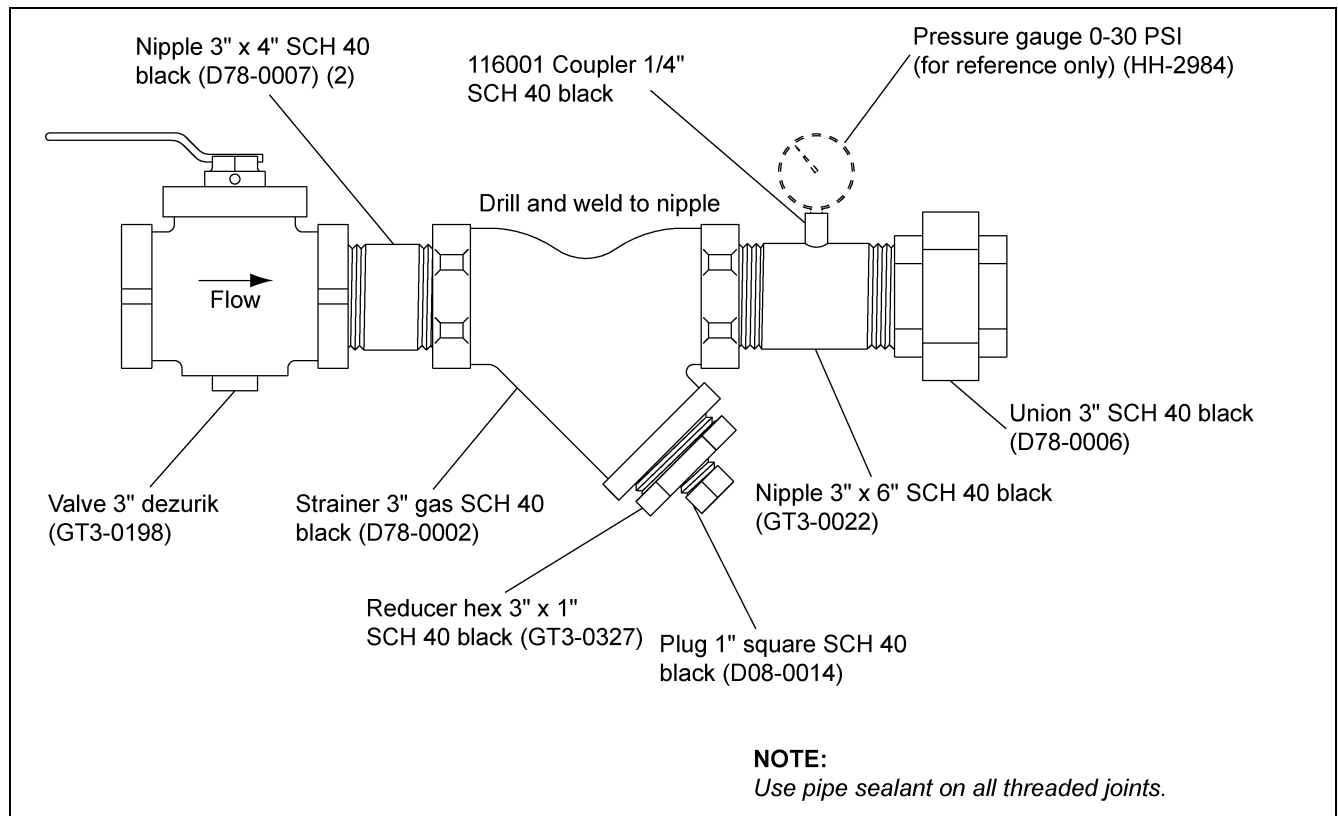

Figure 26BN 3" Shut Off Section - Canadian

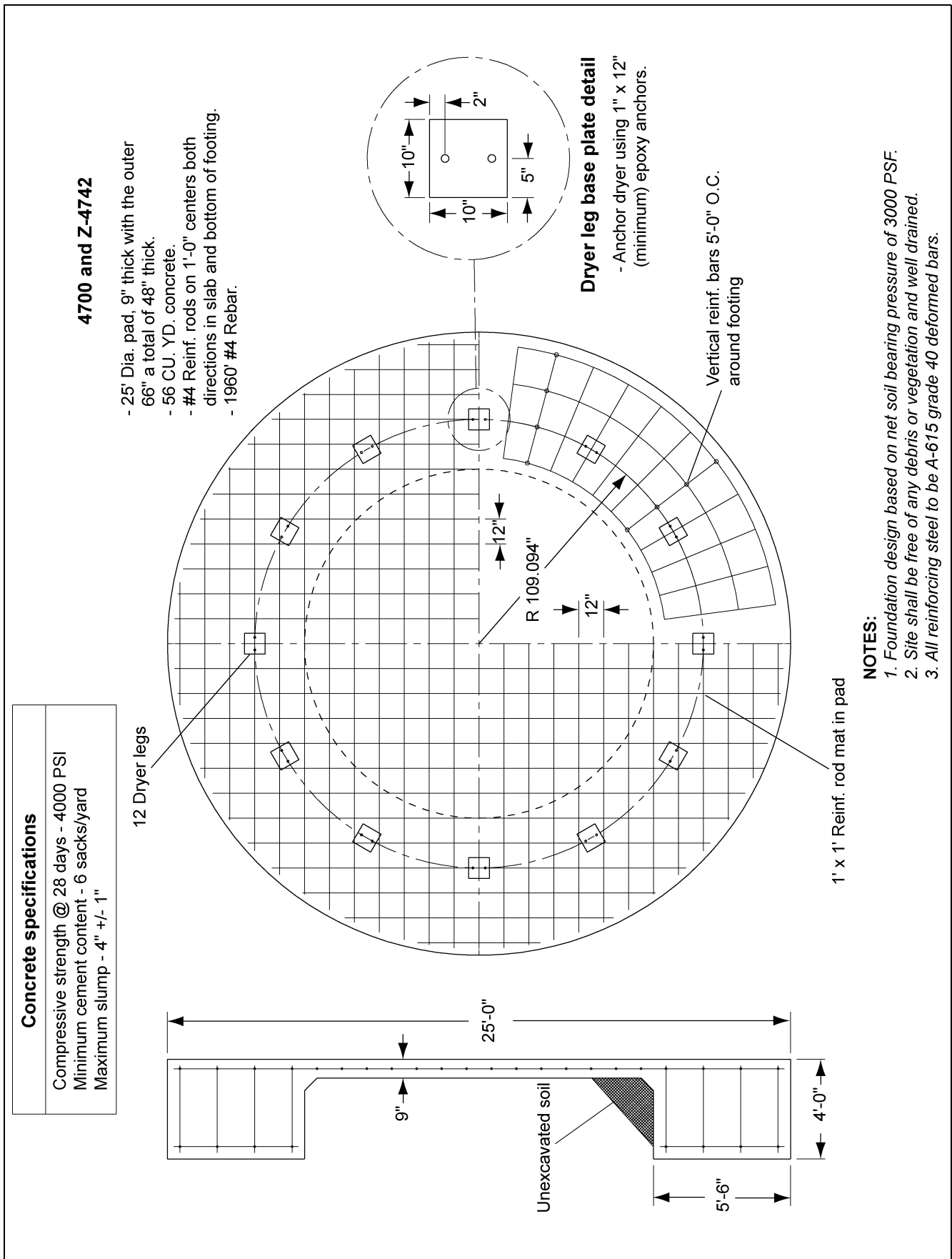

Figure 26BO Foundation Plan 4700 and Z-4742

26. All Tower Dryer Models Drawings

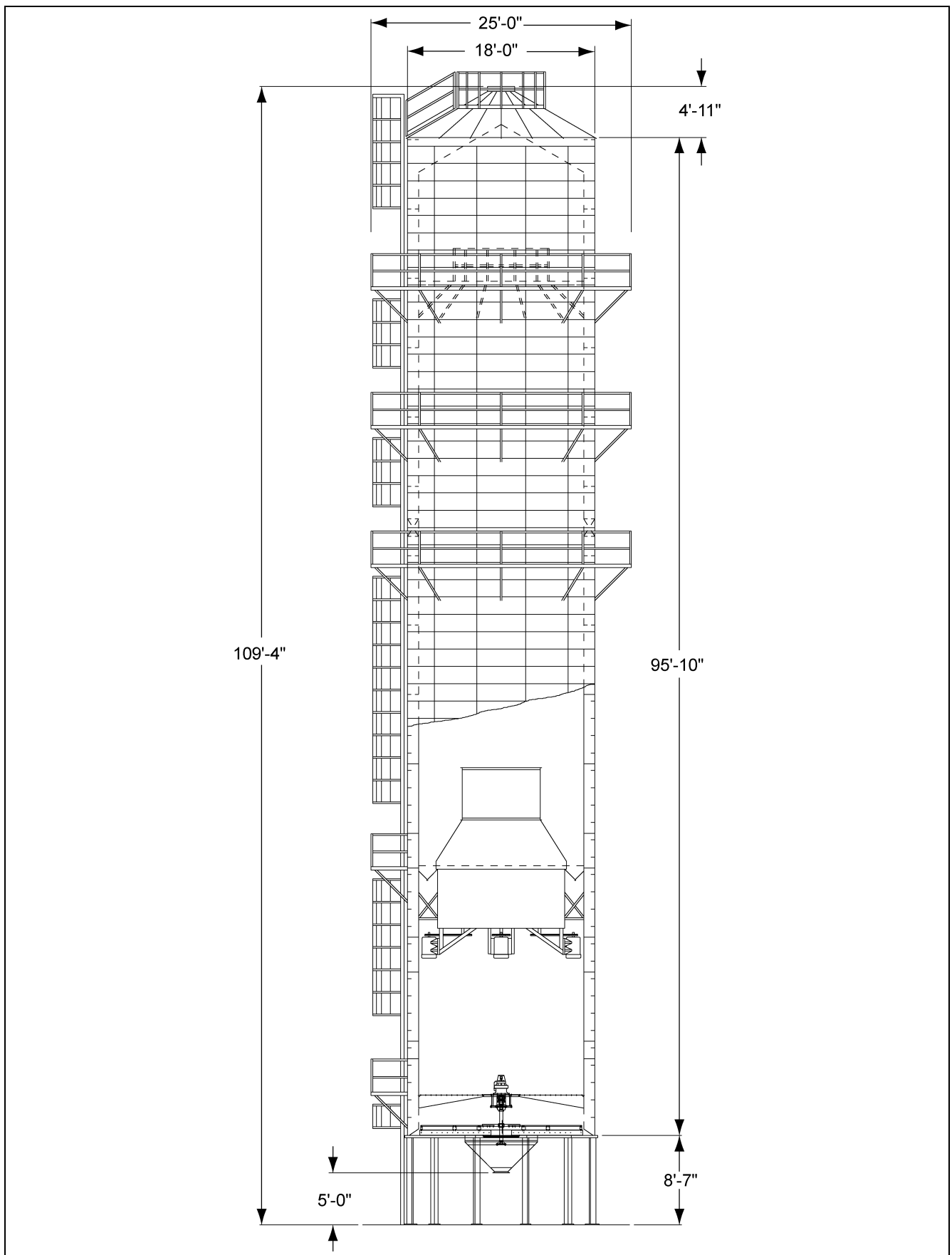

Figure 26BP Zimmerman Tower Dryer Model Z-4742

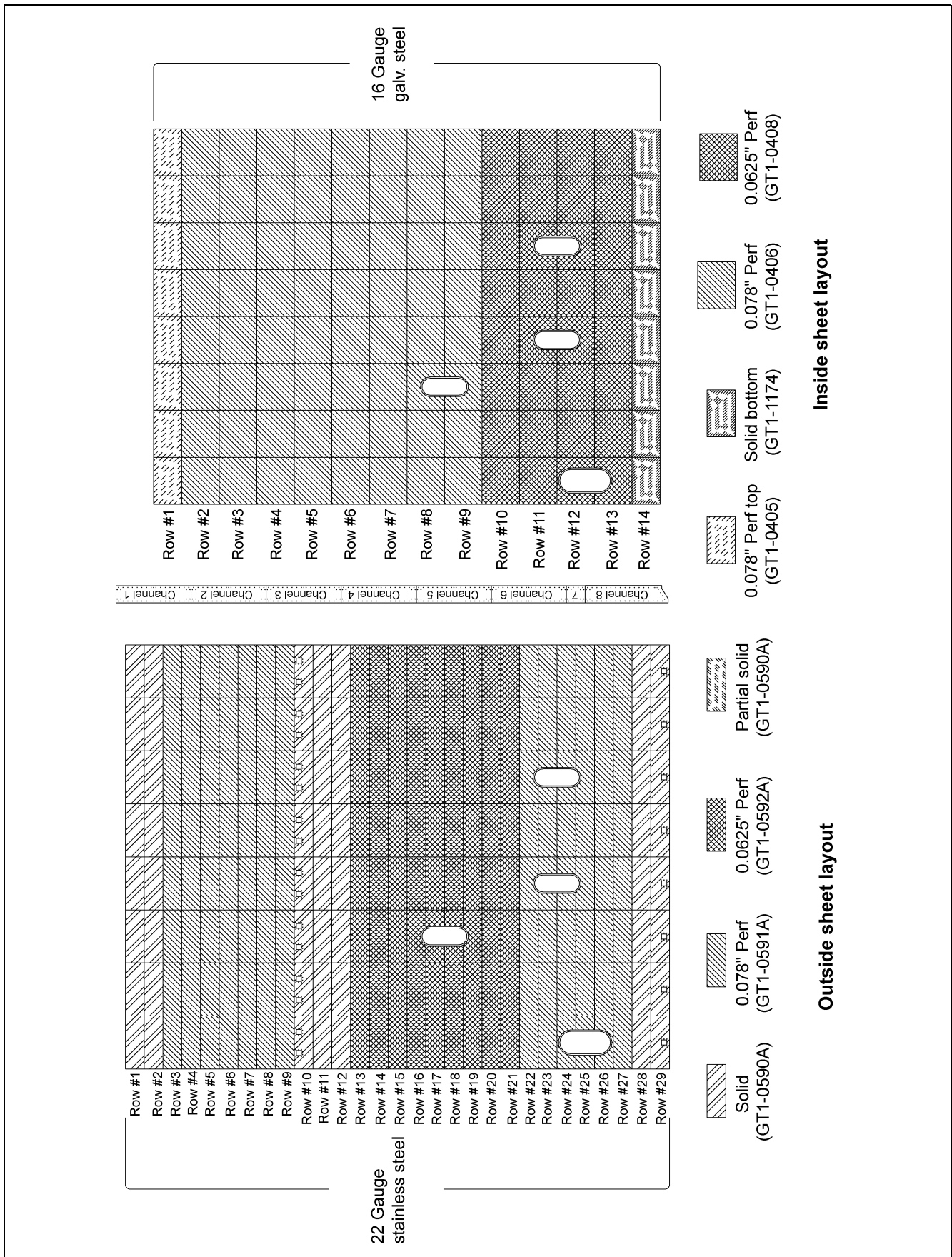

Figure 26BQ Z-1512 and R-3115B

26. All Tower Dryer Models Drawings

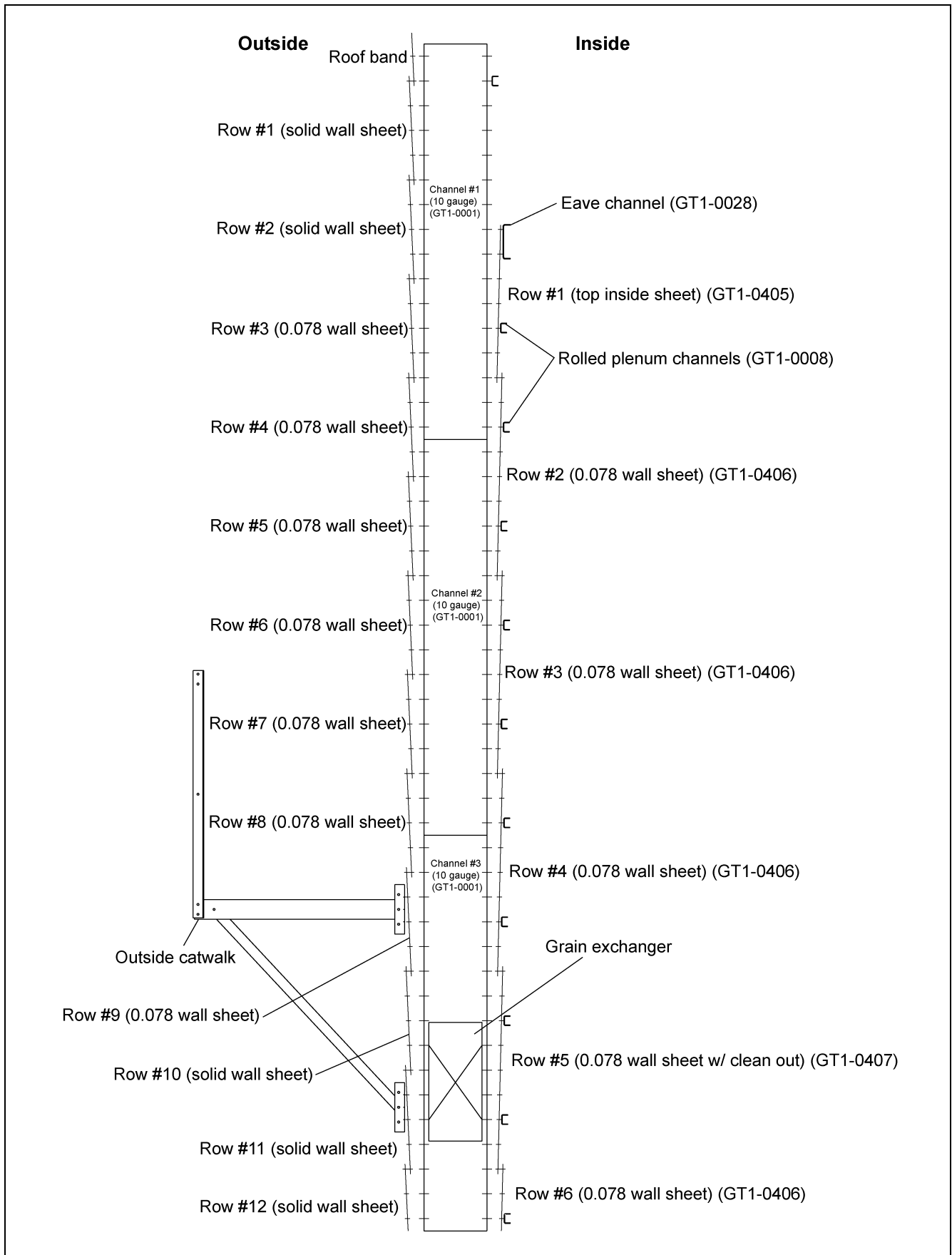

Figure 26BR Clip Placement Z-1512 Channels 1 to 3

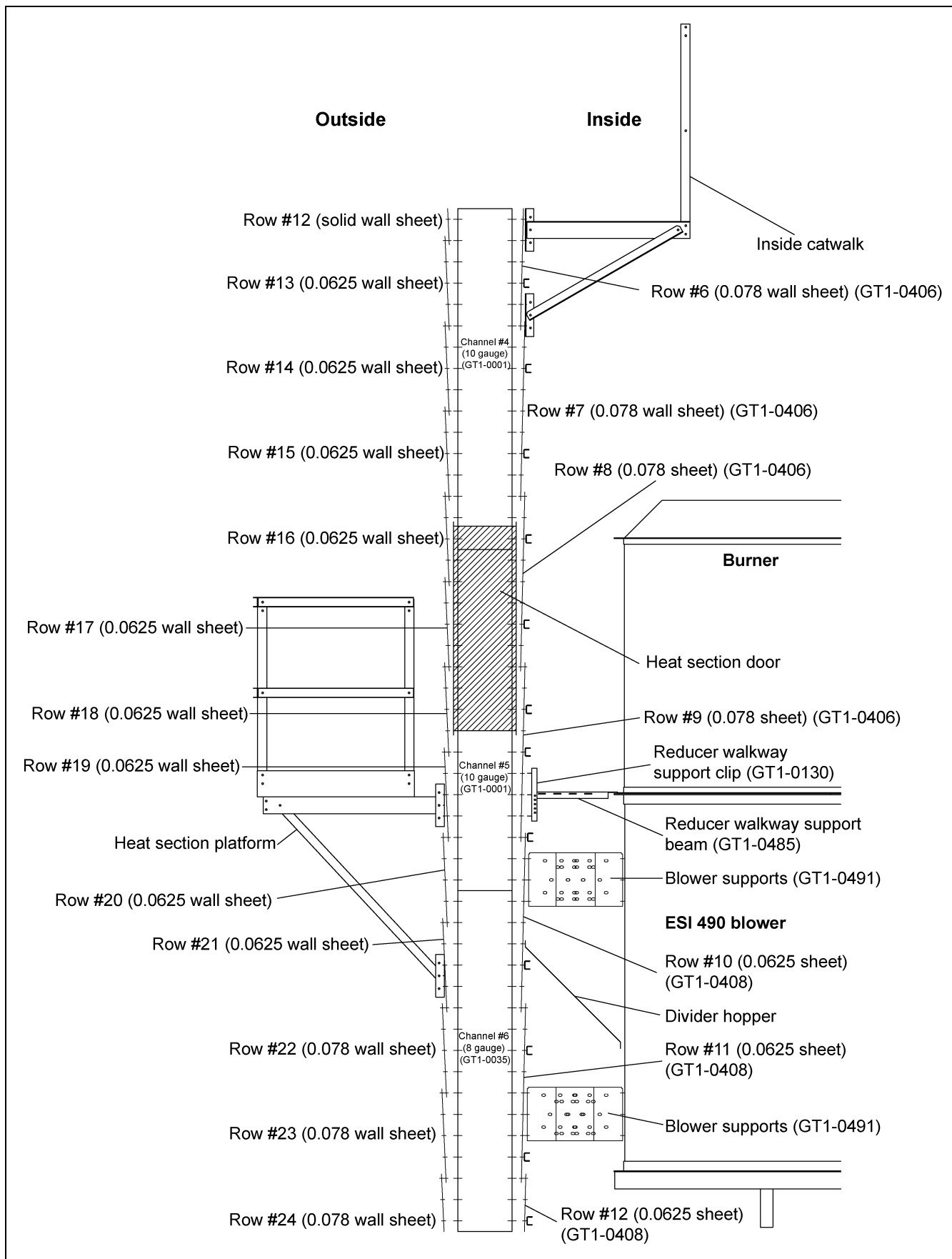

Figure 26BS Clip Placement Z-1512 Channels 4 to 6

26. All Tower Dryer Models Drawings

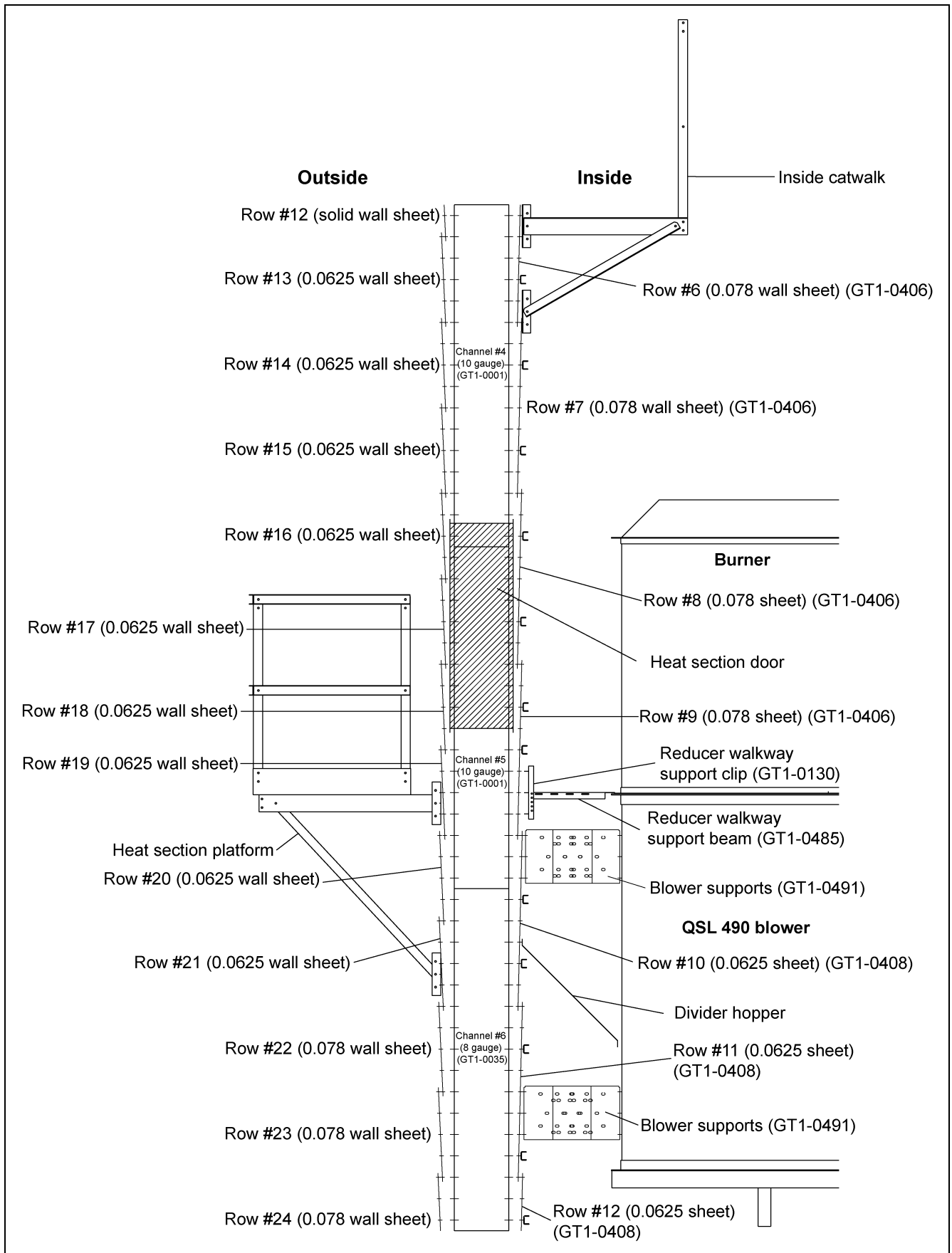

Figure 26BT Clip Placement Z-1512 w/ QSL Blower Channels 4 to 6

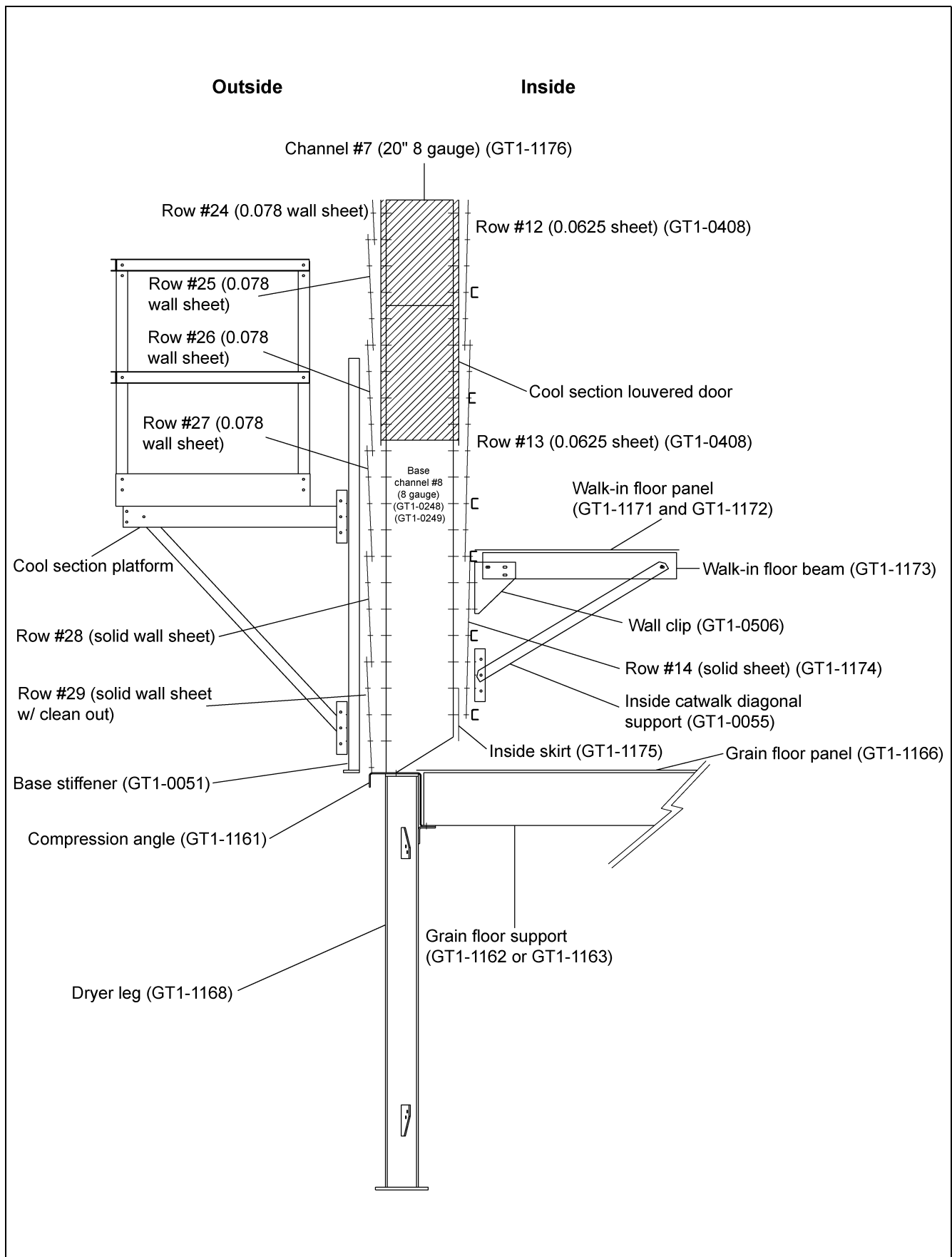

Figure 26BU Clip Placement Z-1512 Channels 7 to 8

26. All Tower Dryer Models Drawings

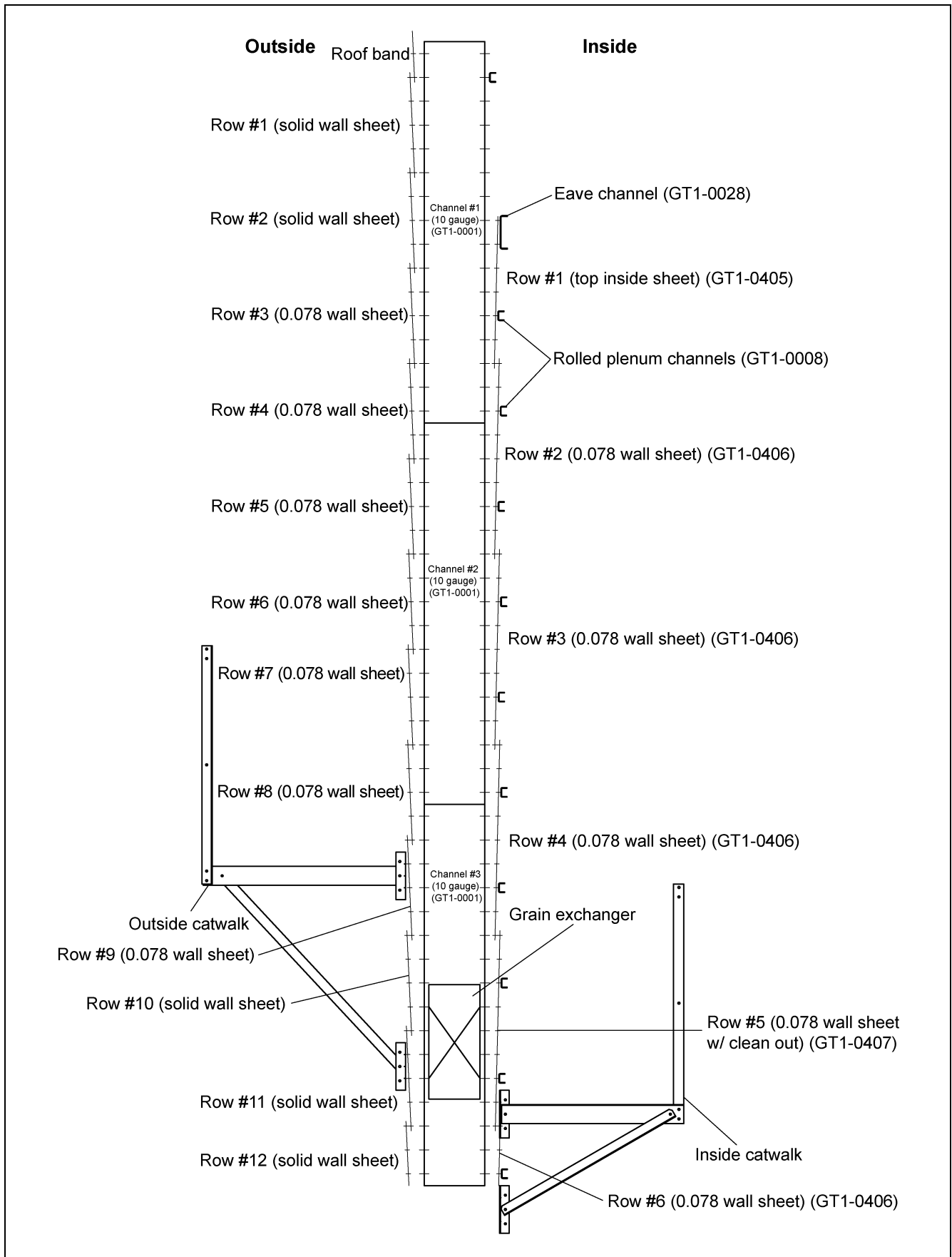

Figure 26BV Clip Placement Z-1512 Channels 1 to 3

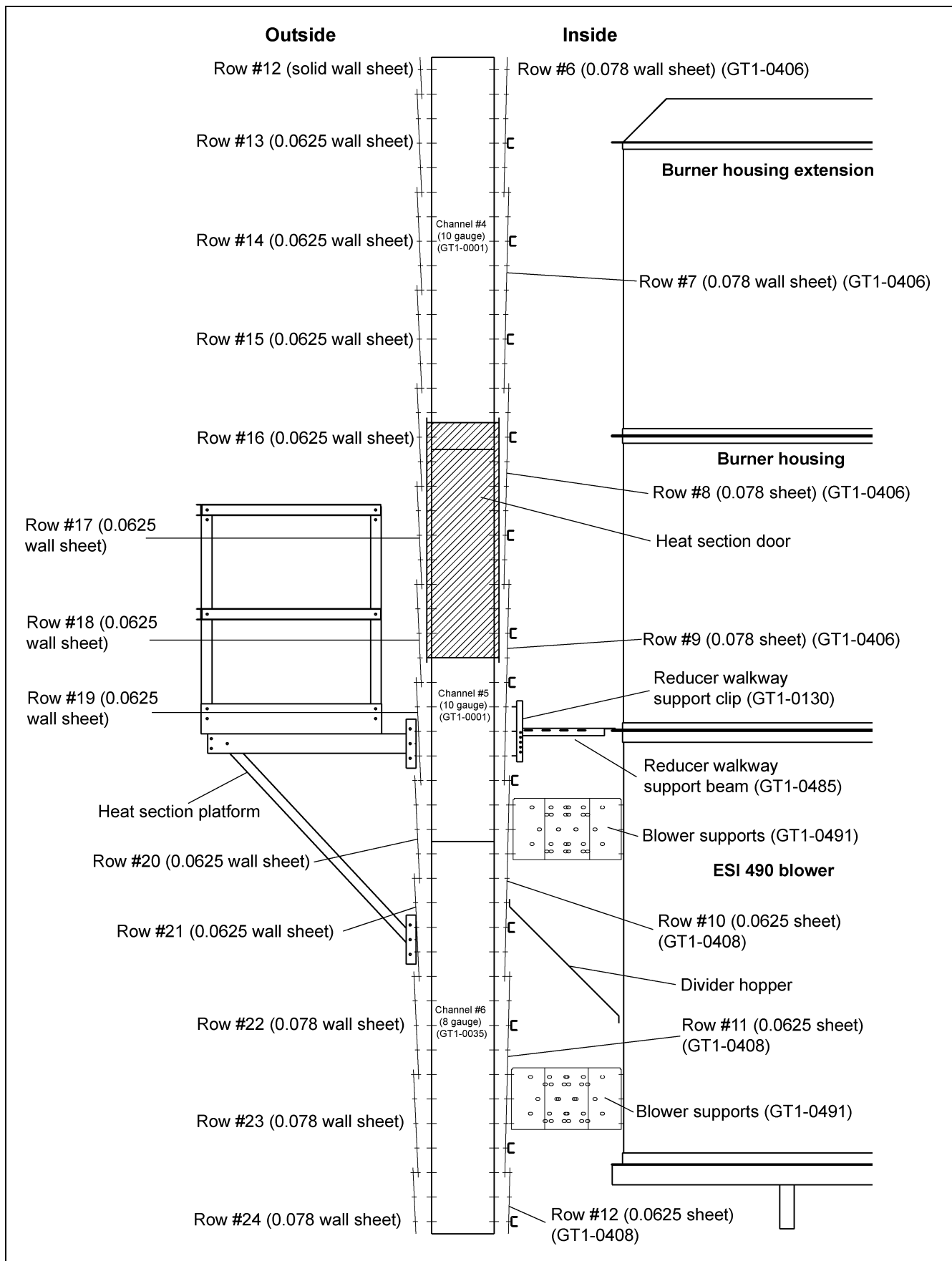

Figure 26BW Clip Placement Z-1512-Oil Channels 4 to 6

26. All Tower Dryer Models Drawings

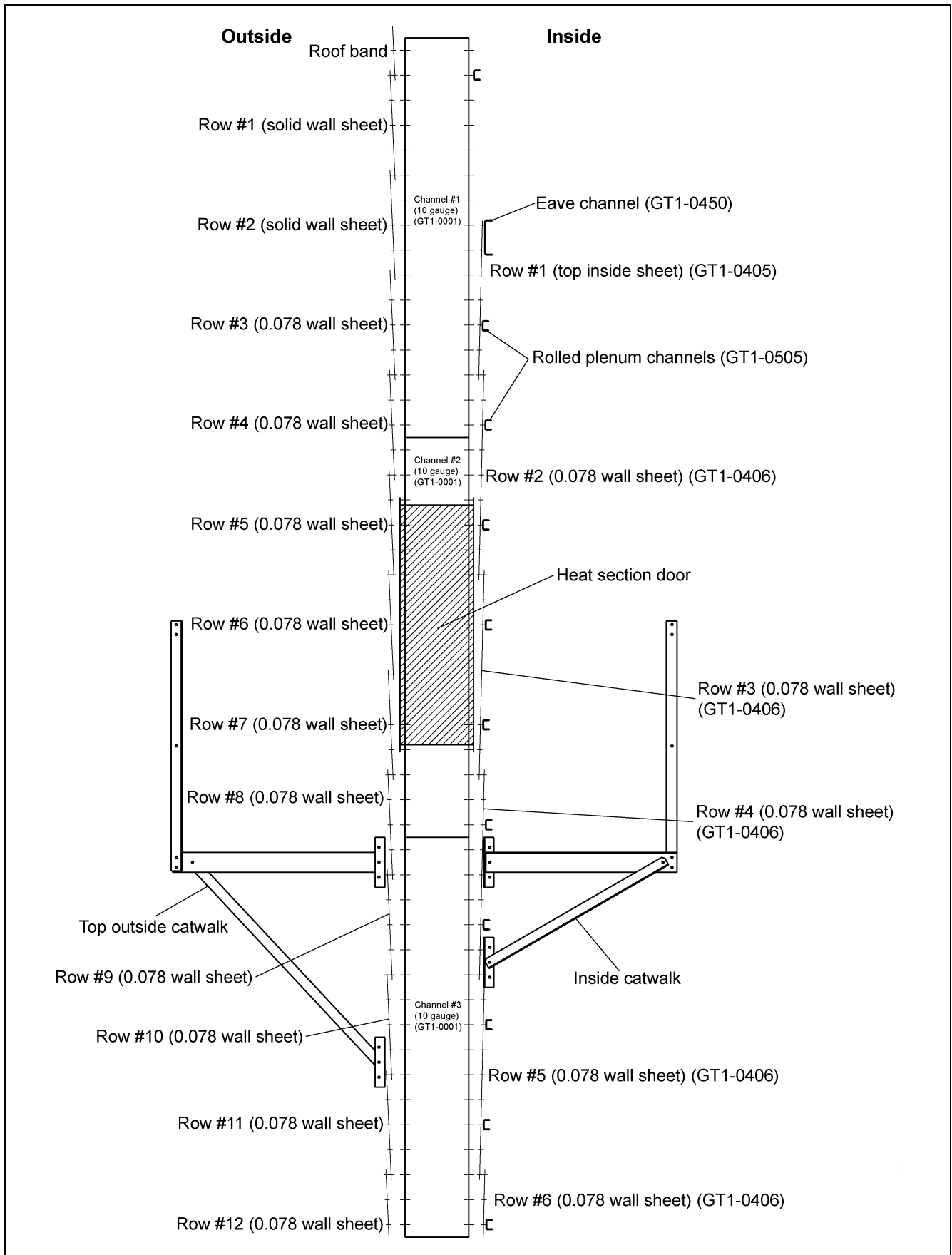

Figure 26BX Clip Placement Z-1816 Channels 1 to 3

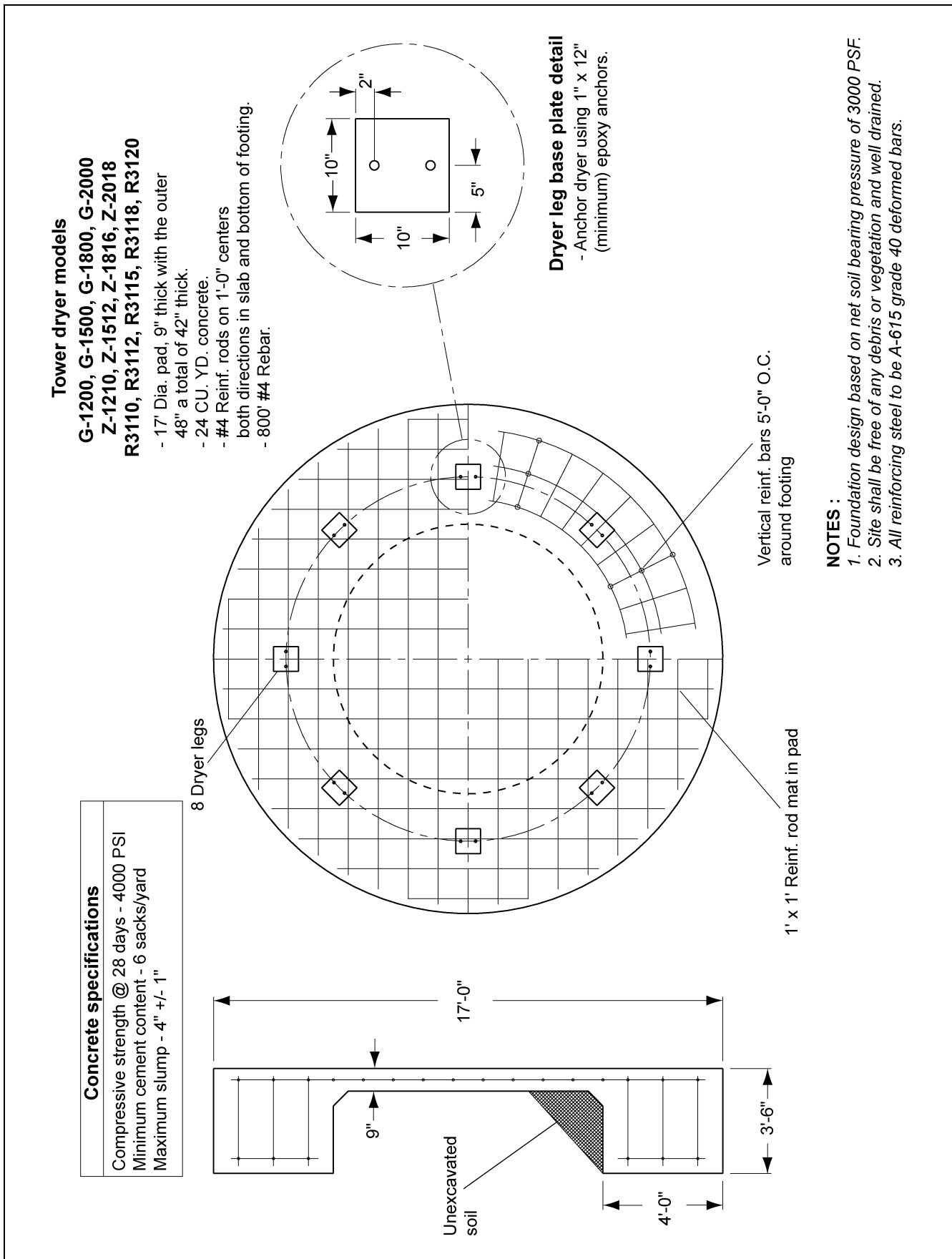

Figure 26BY Foundation Plan Central United States

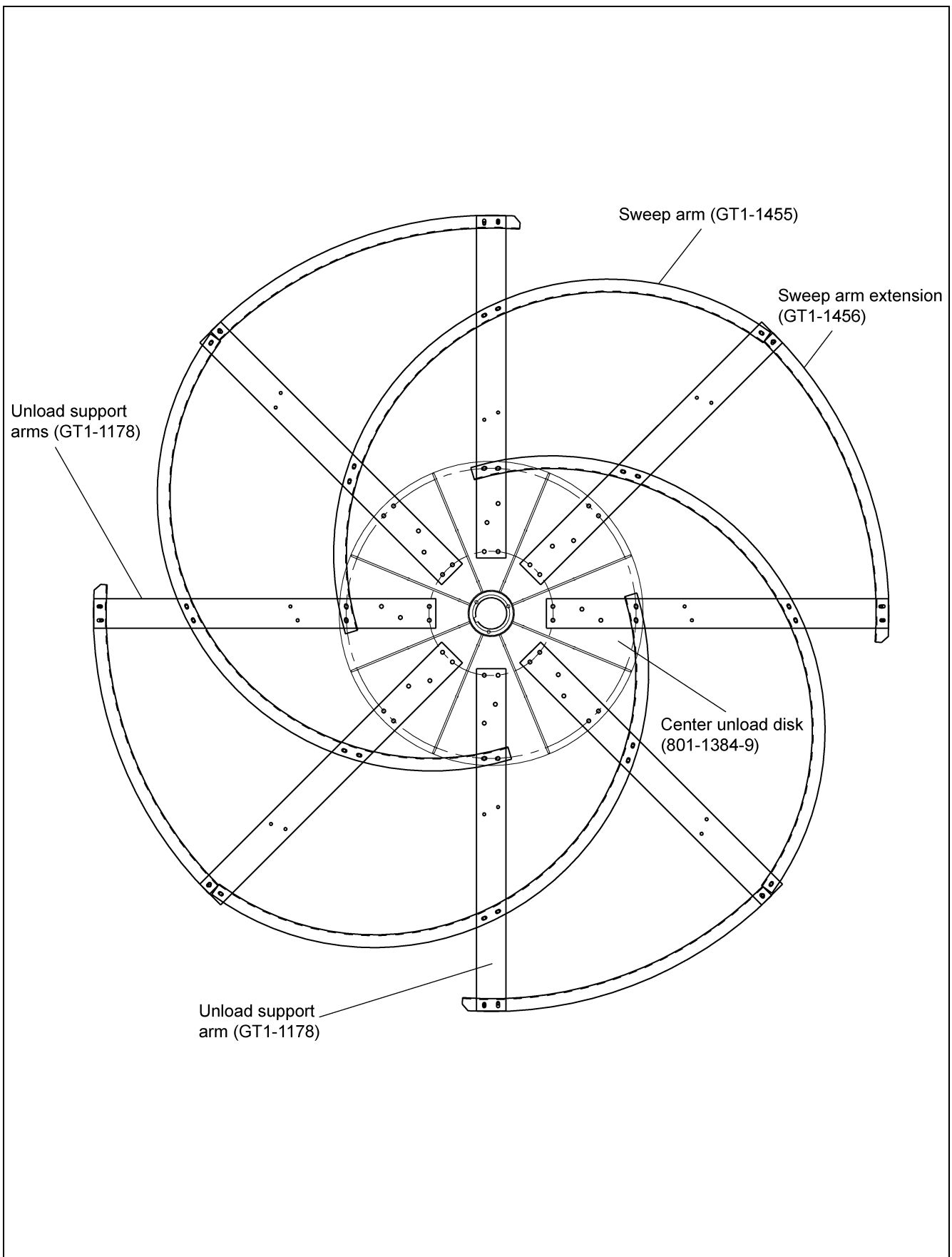

Figure 26BZ 2006 Zimmerman 12' Sweep Unload

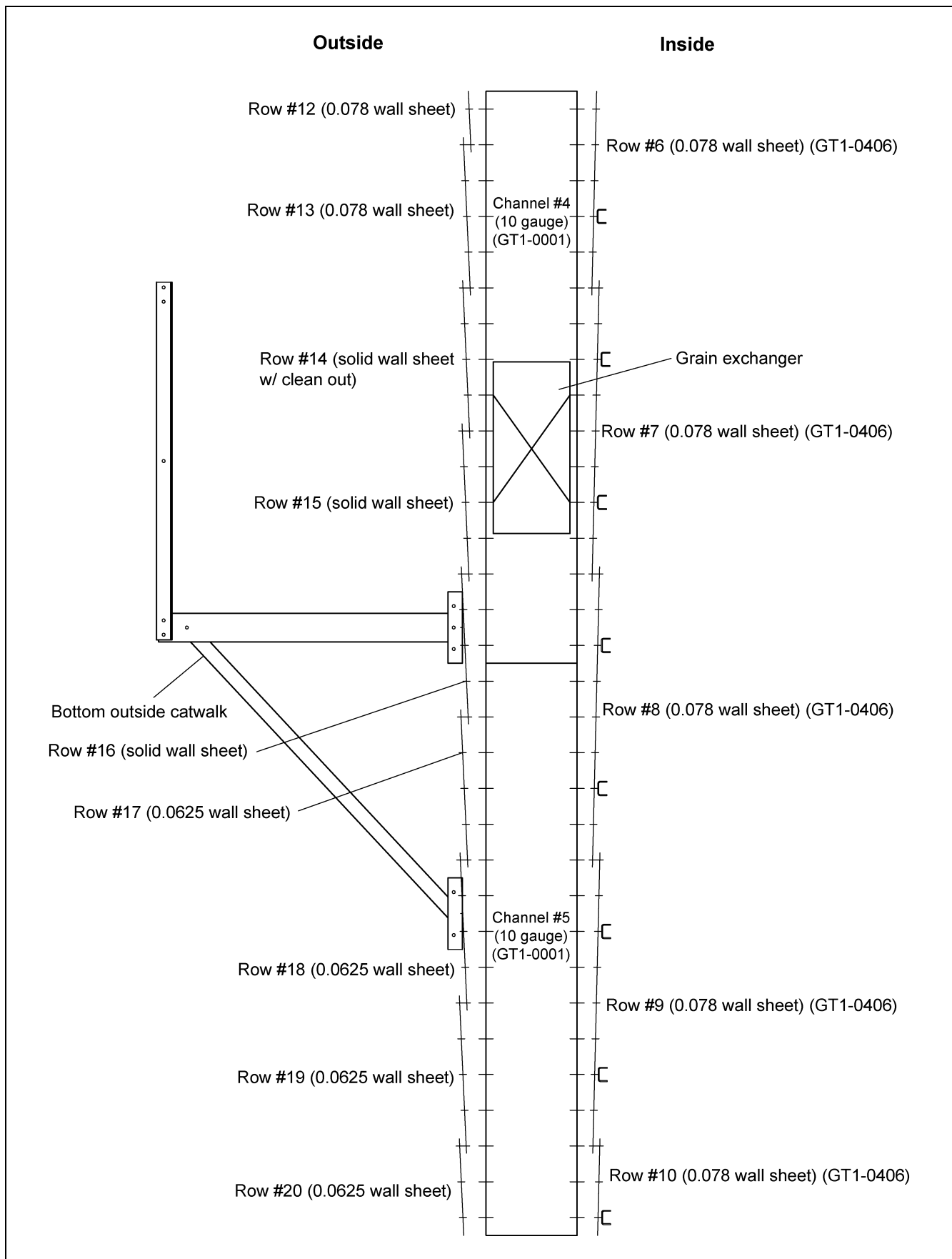

Figure 26CA Clip Placement Z-1816 Channels 4 to 5

26. All Tower Dryer Models Drawings

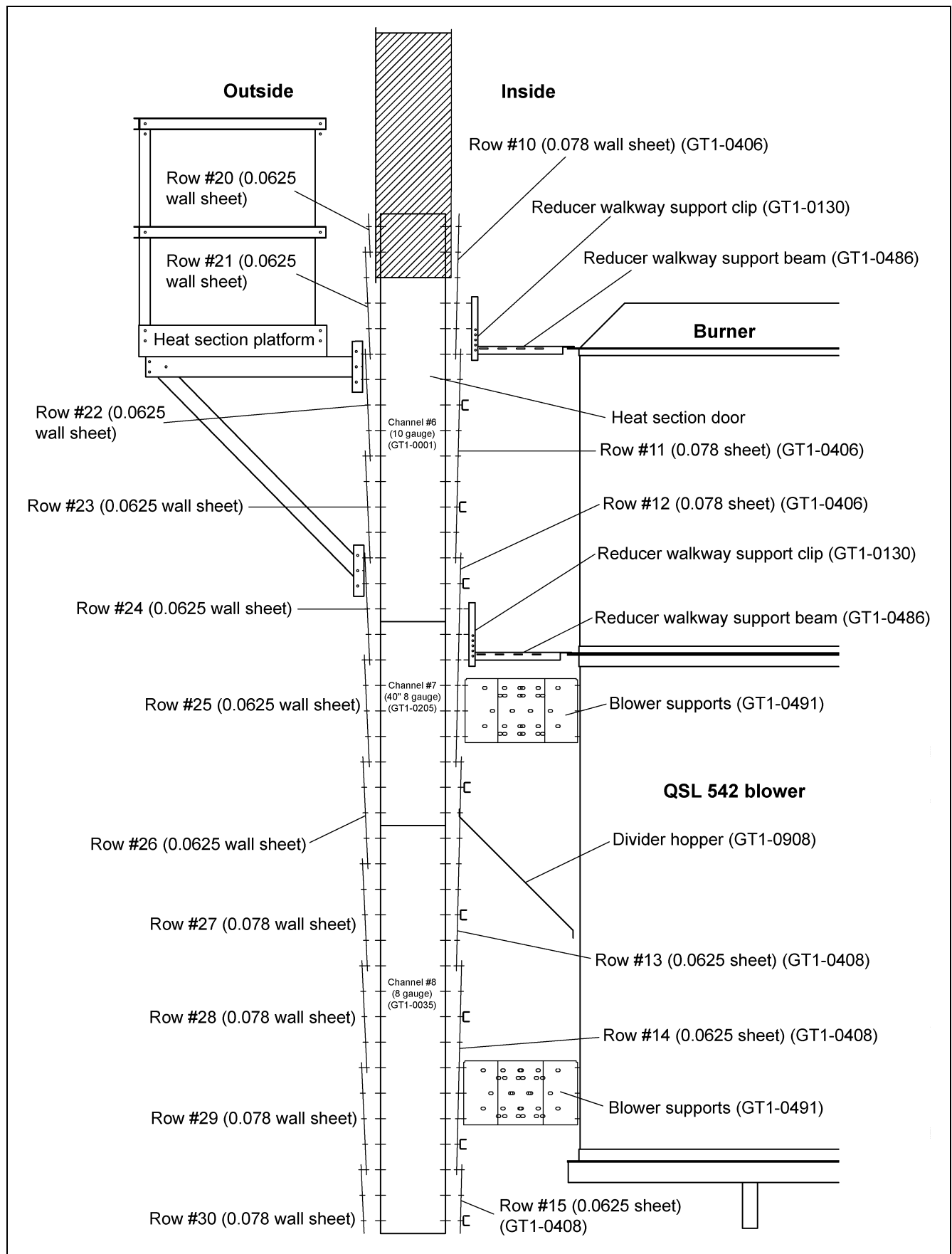

Figure 26CB Clip Placement Z-1816 Channels 6 to 8

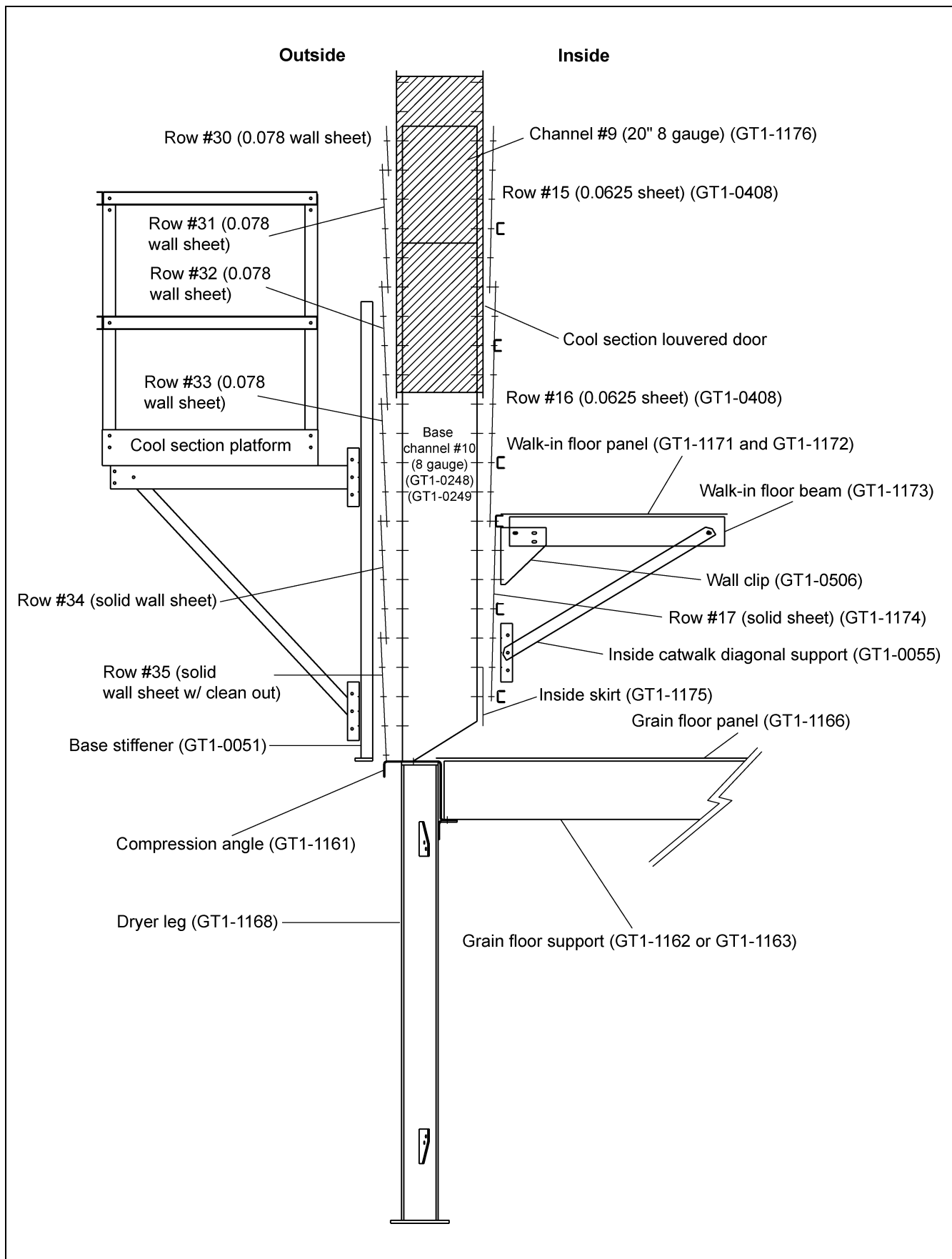

Figure 26CC Clip Placement Z-1816 Channels 9 to 10

26. All Tower Dryer Models Drawings

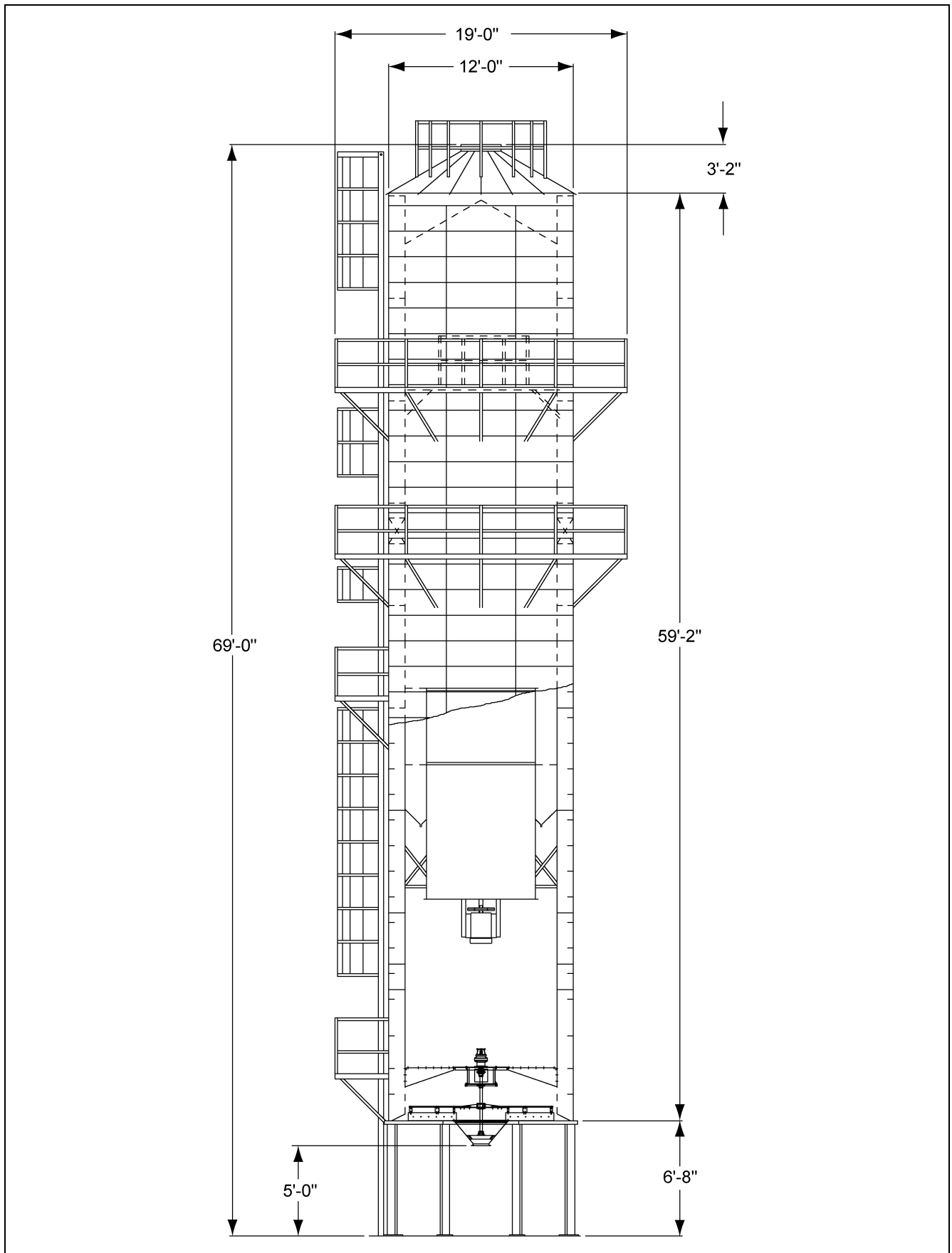

Figure 26CD Zimmerman Tower Dryer Model Z-1816

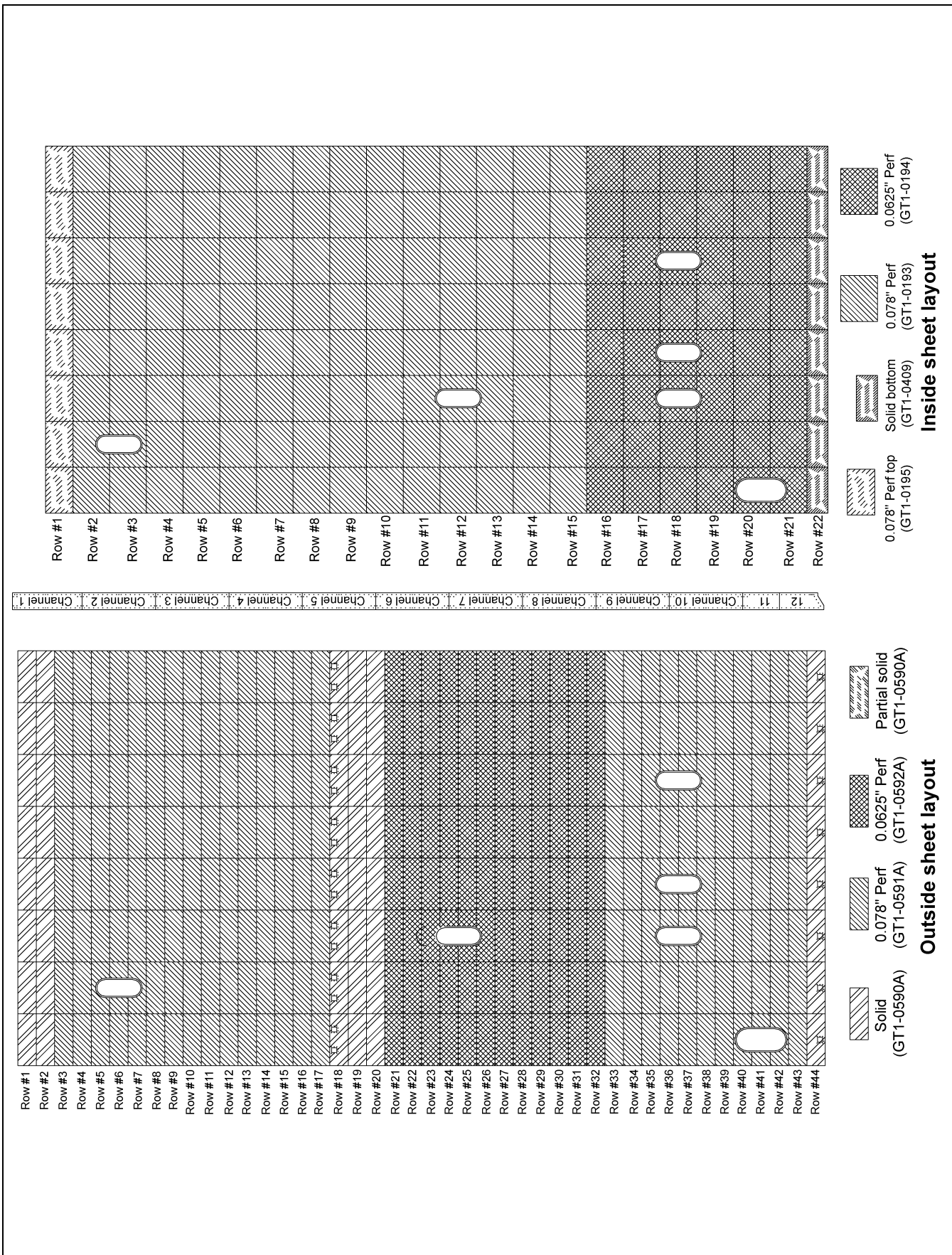

Figure 26CE G-2400 Sheet Layout

26. All Tower Dryer Models Drawings

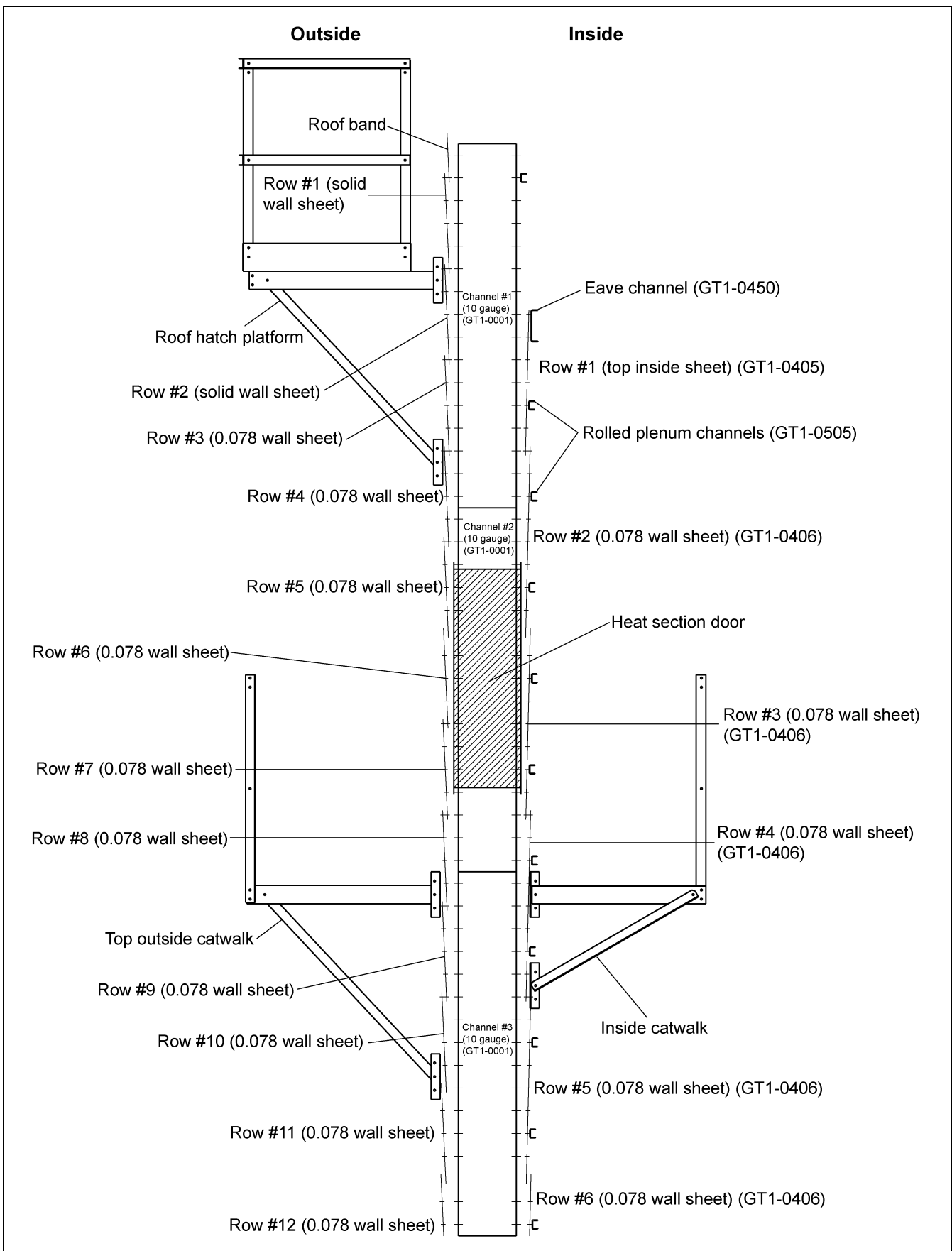

Figure 26CF Clip Placement Model 2400 Channels 1 to 3

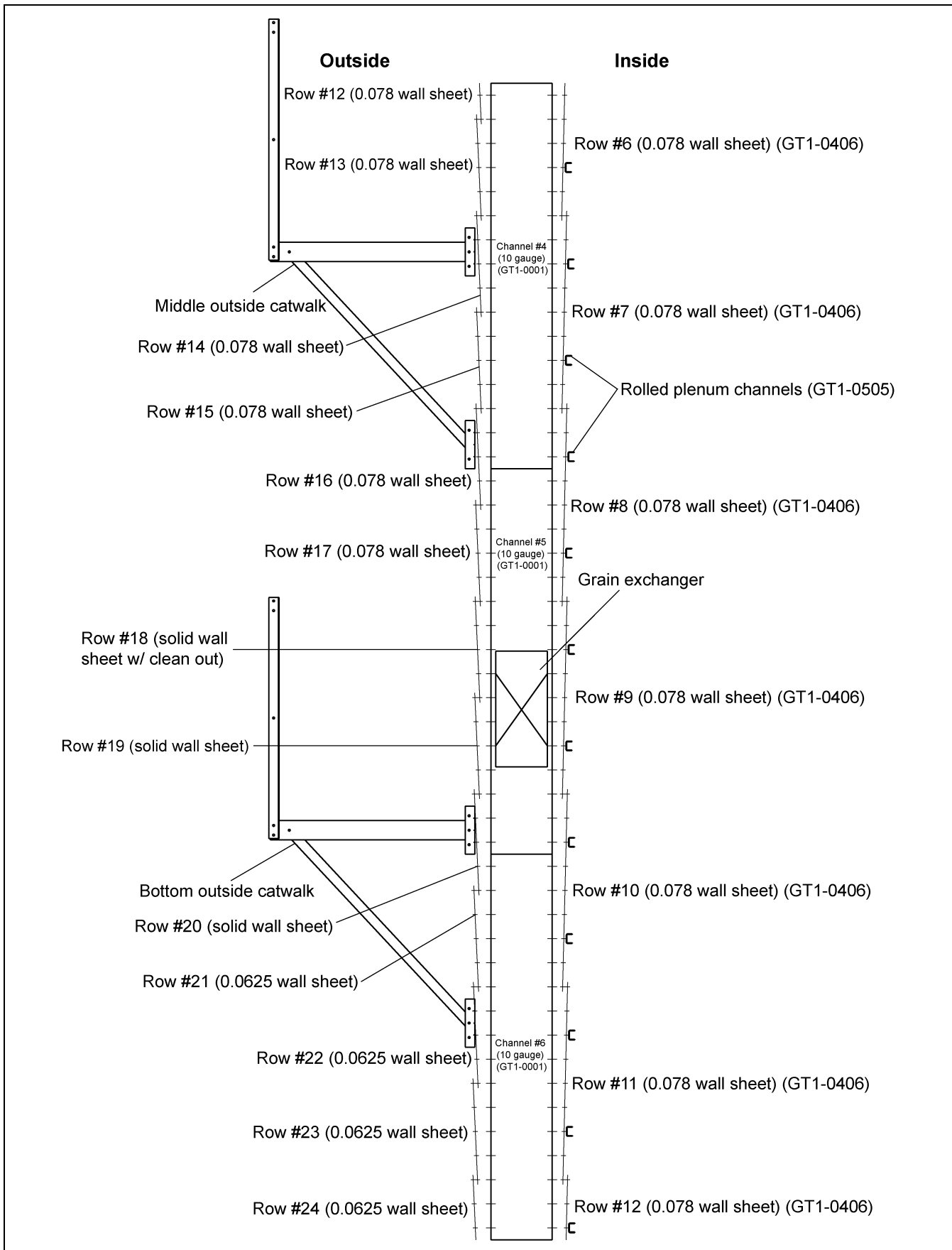

Figure 26CG Clip Placement Model 2400 Channels 4 to 6

26. All Tower Dryer Models Drawings

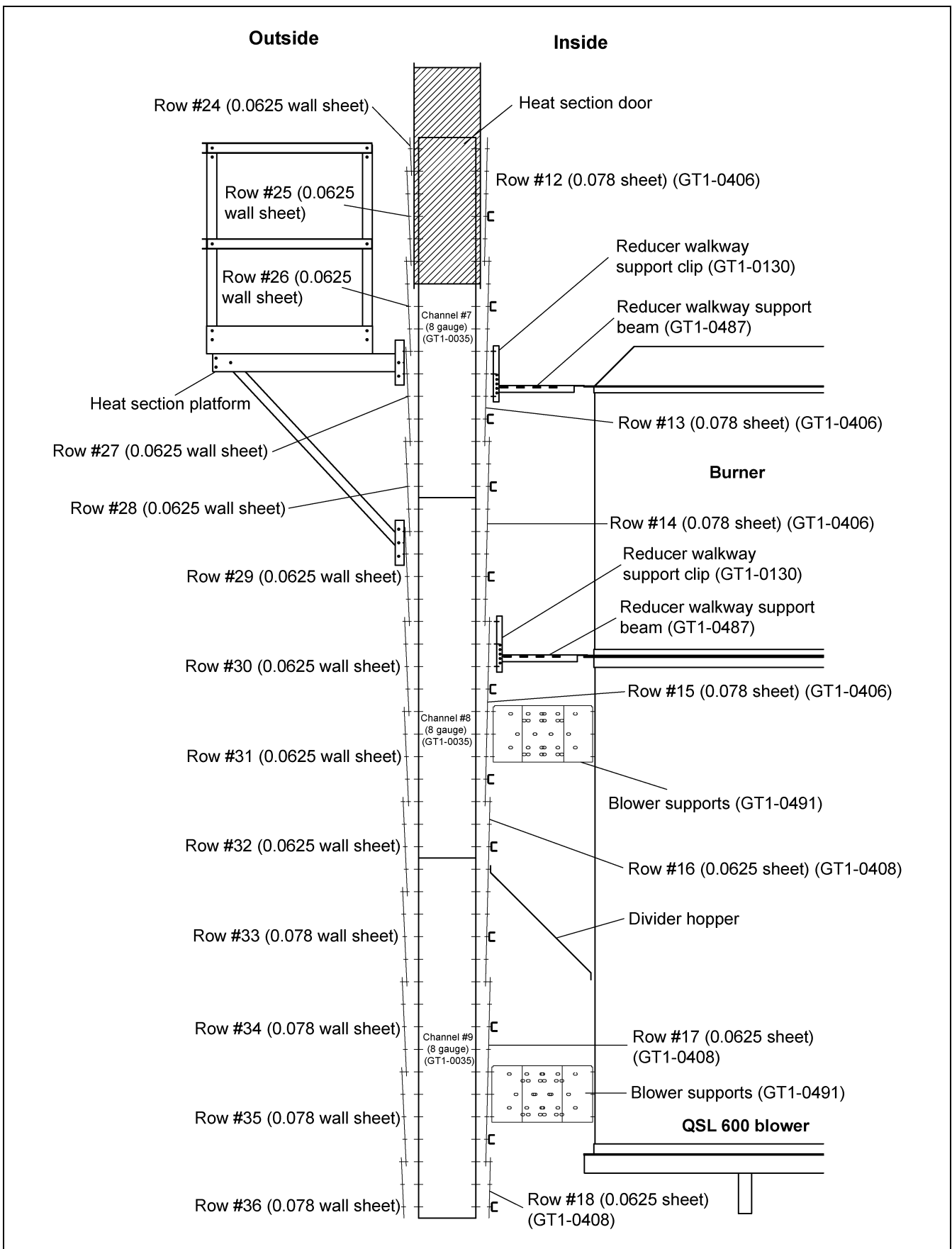

Figure 26CH Clip Placement Model 2400 w/ QSL Blower Channels 7 to 9

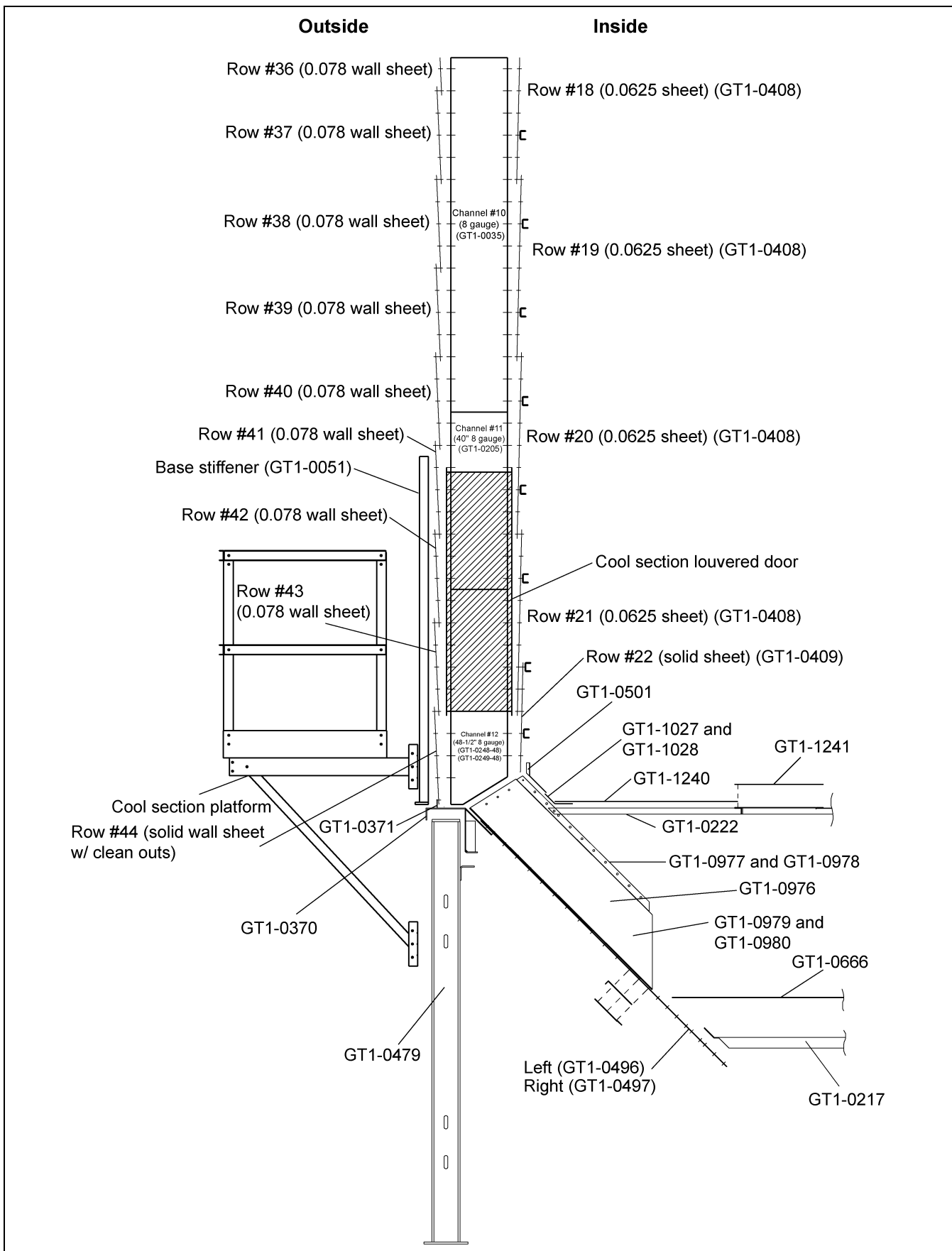

Figure 26CI Clip Placement G-2400 Channels 10 to 12

26. All Tower Dryer Models Drawings

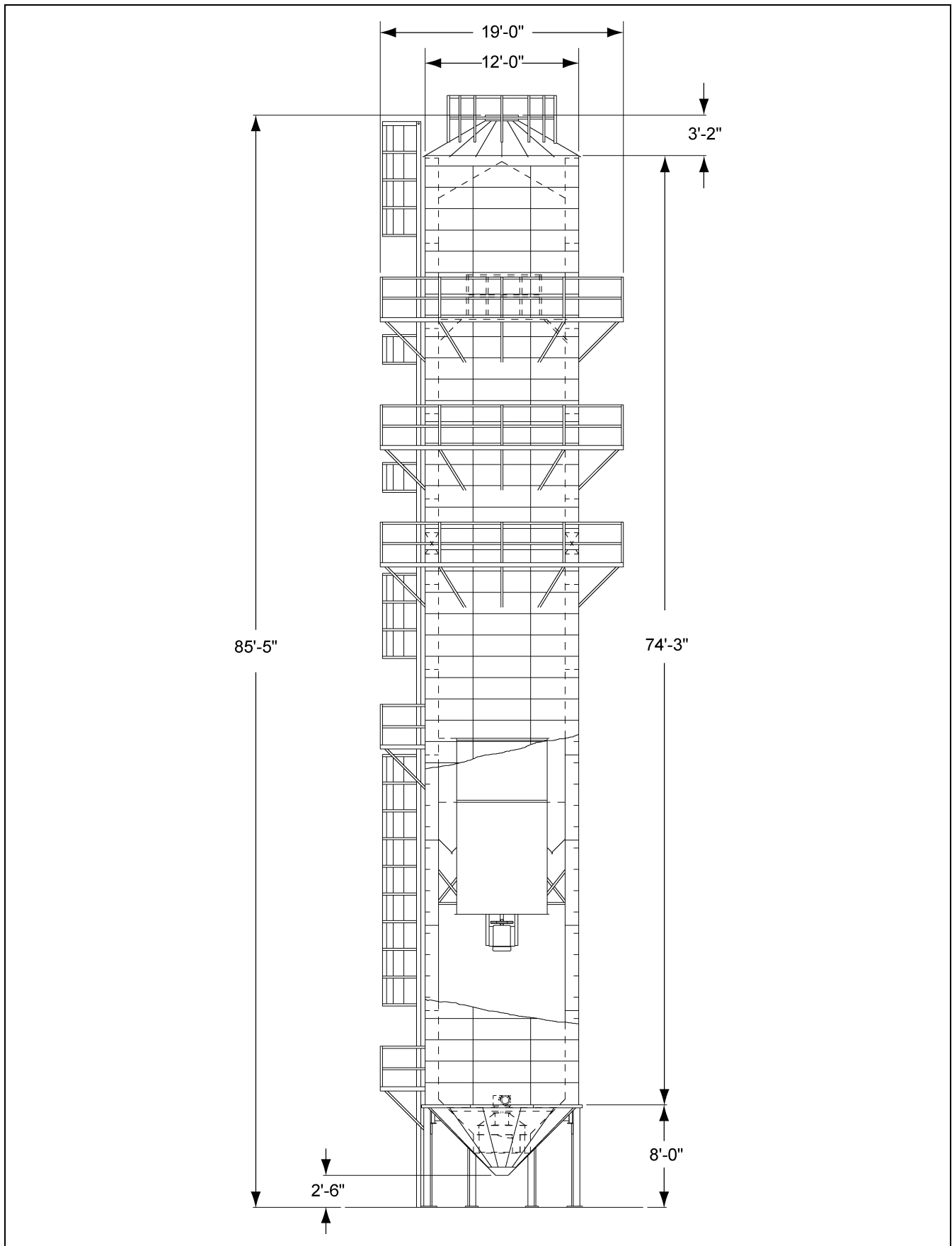

Figure 26CJ GSI Tower Dryer Model 2400

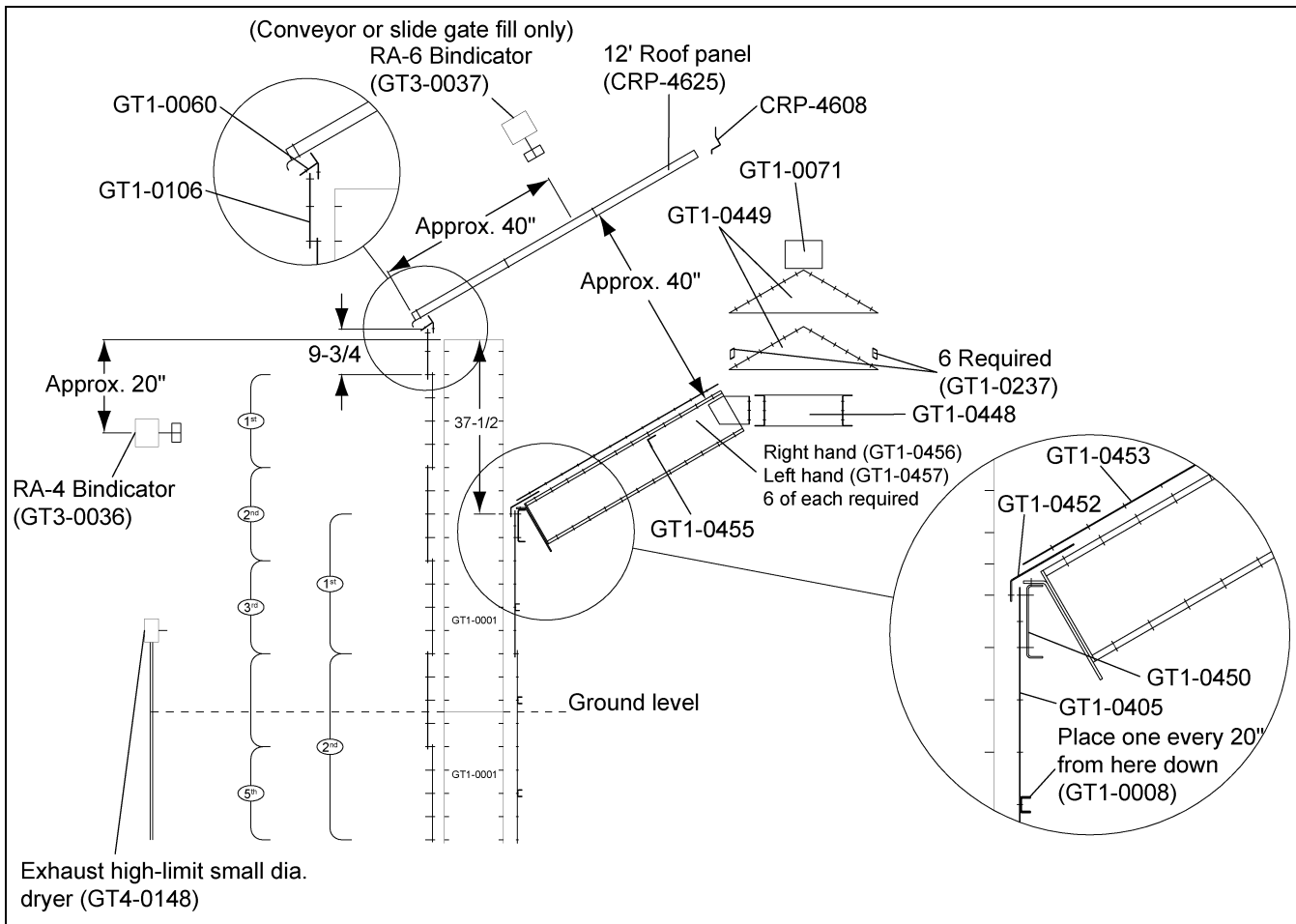

Figure 26CK Plenum Roof Detail 12'

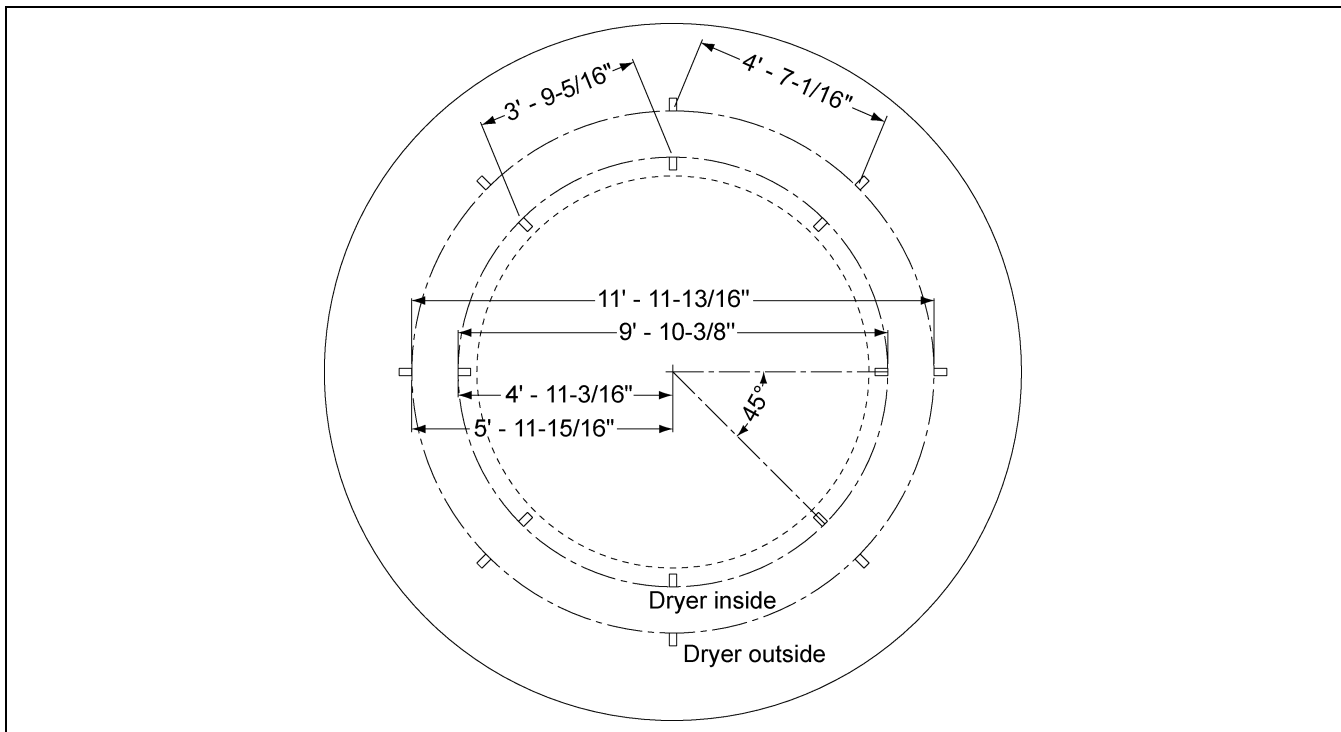

Figure 26CL Jig Clip Positions All 12' Diameter Dryer Models

26. All Tower Dryer Models Drawings

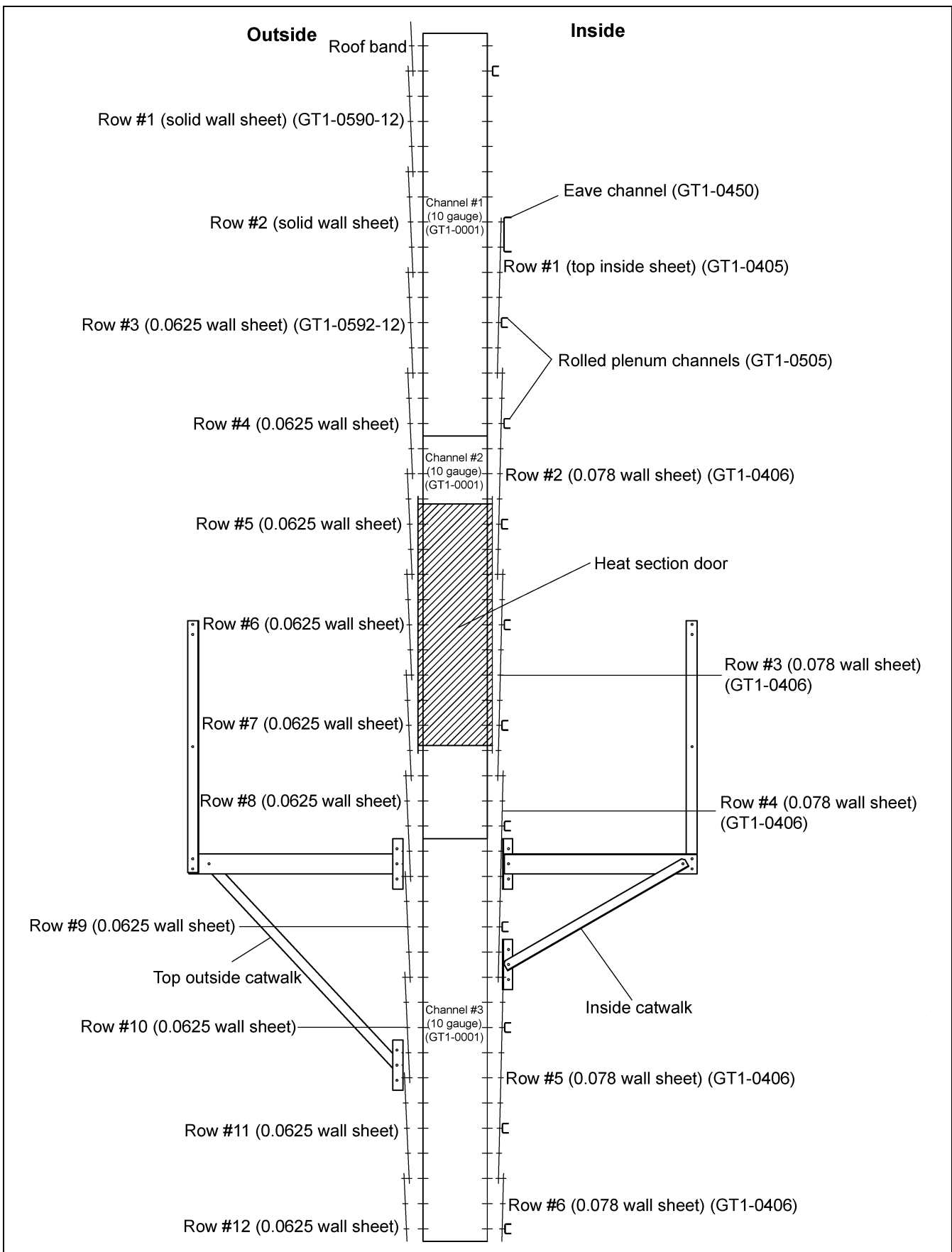

Figure 26CM Clip Placement Model 2400 Channels 1 to 3

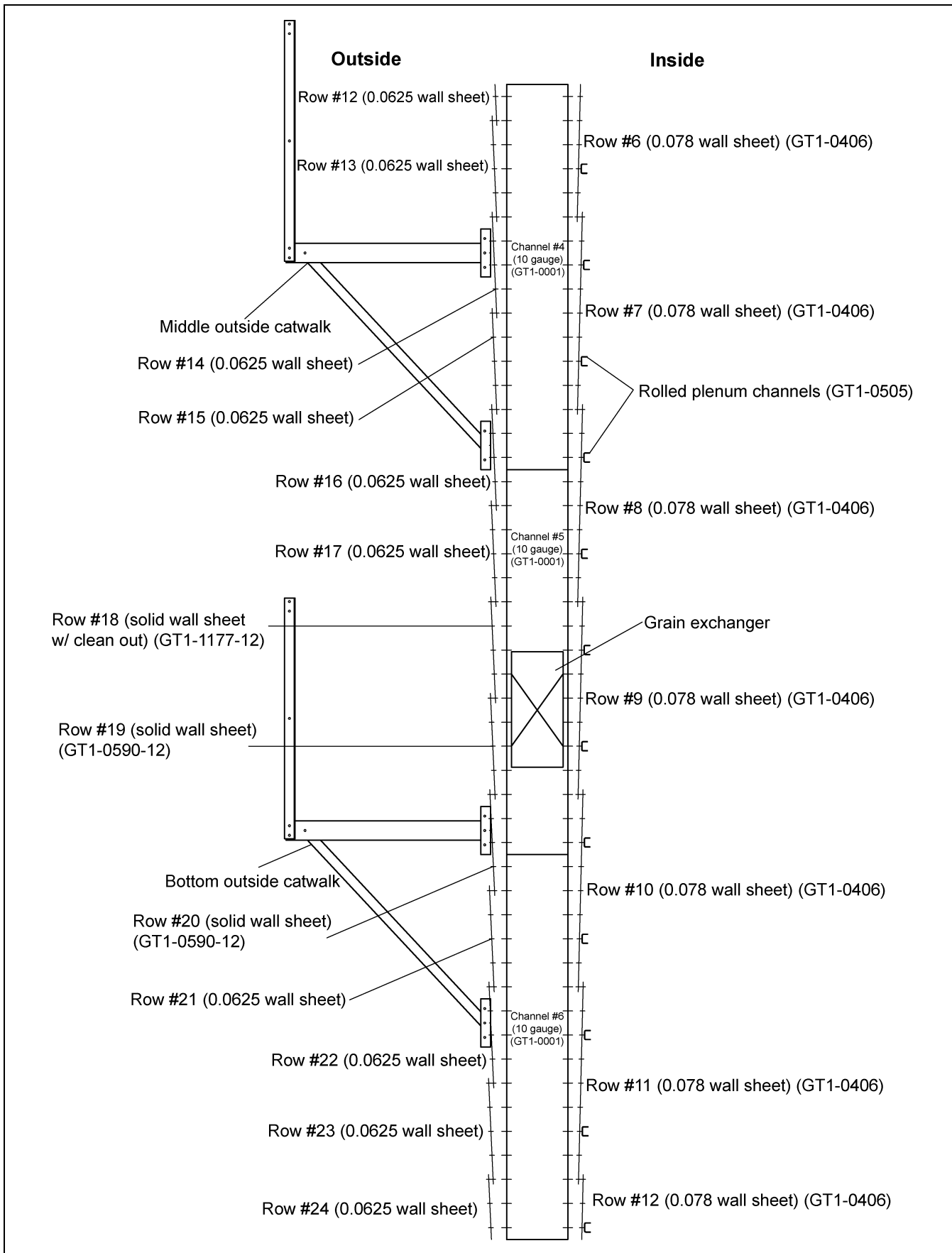

Figure 26CN Clip Placement Model 2400 Channels 4 to 6

26. All Tower Dryer Models Drawings

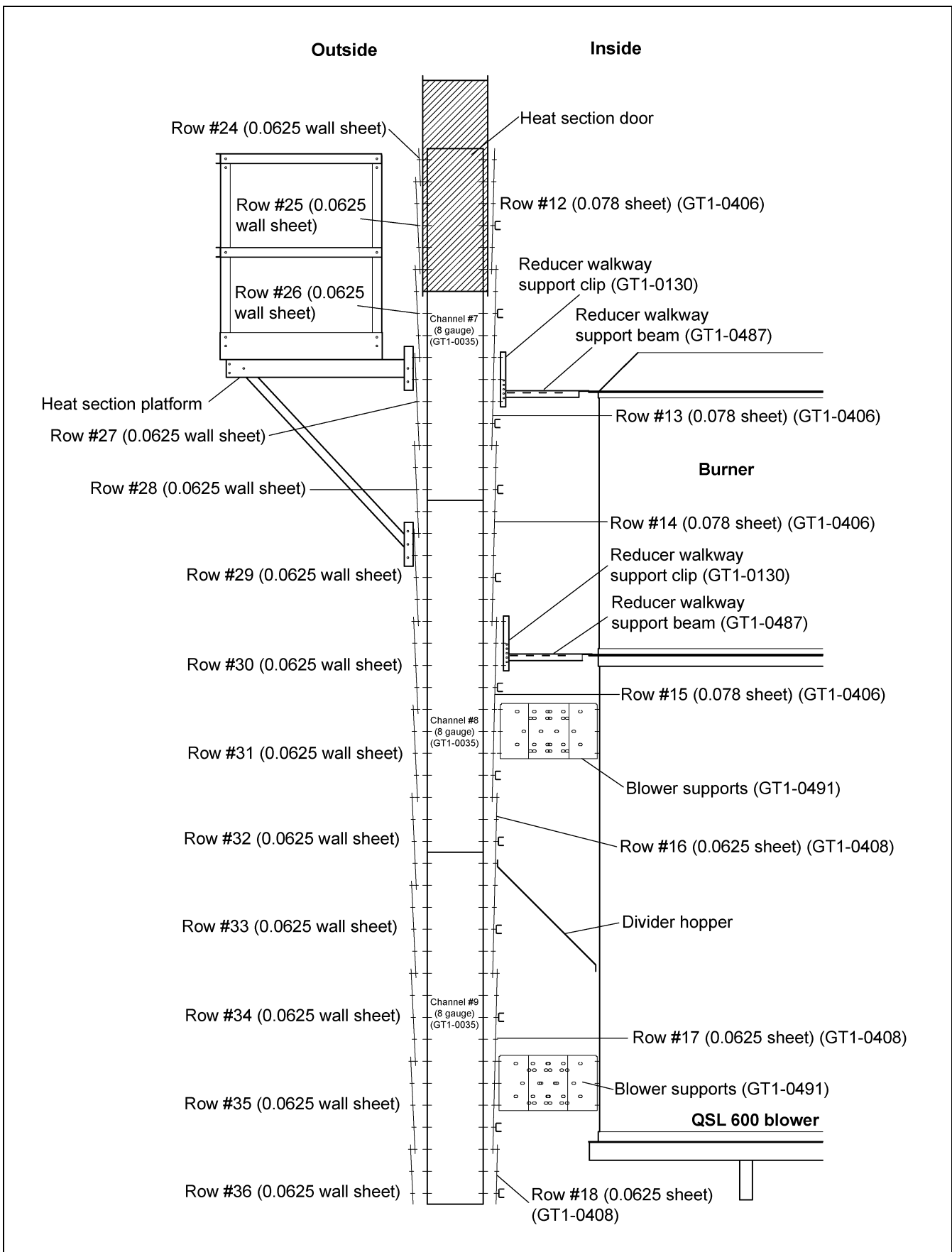

Figure 26CO Clip Placement Model 2400 w/ QSL Blower Channels 7 to 9

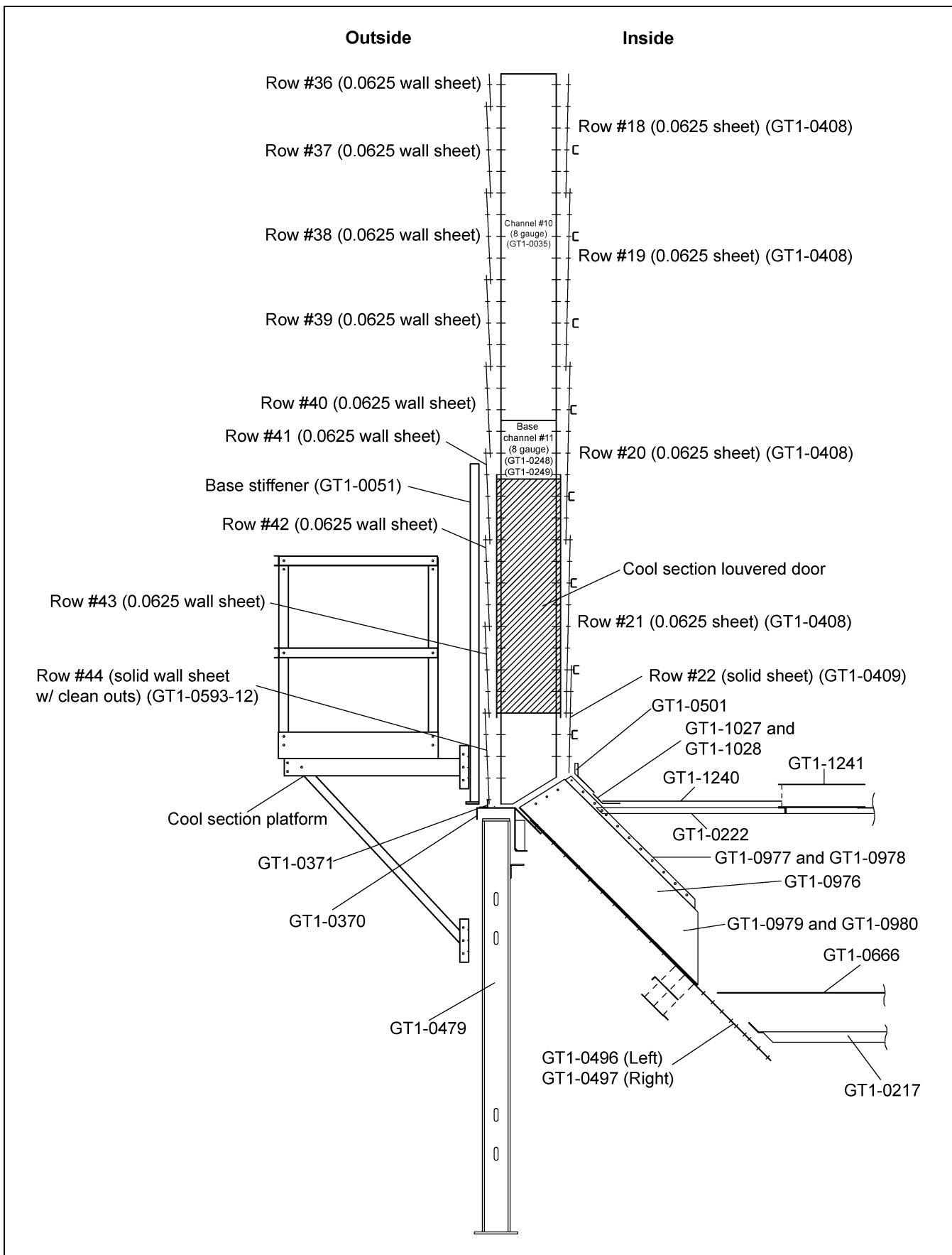

Figure 26CP Clip Placement Model 2400 Channels 10 to 11

26. All Tower Dryer Models Drawings

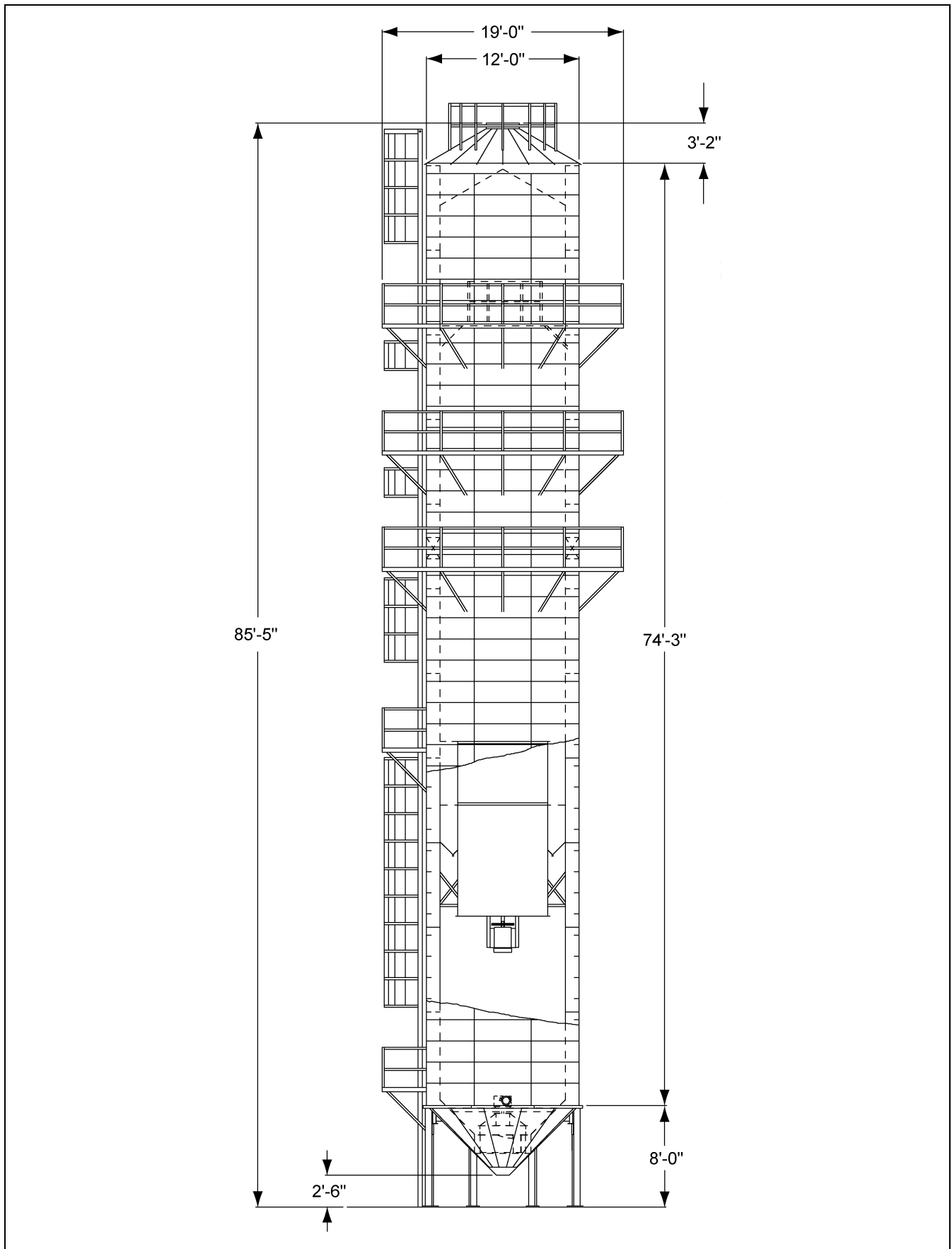

Figure 26CQ GSI Tower Dryer Model 2400

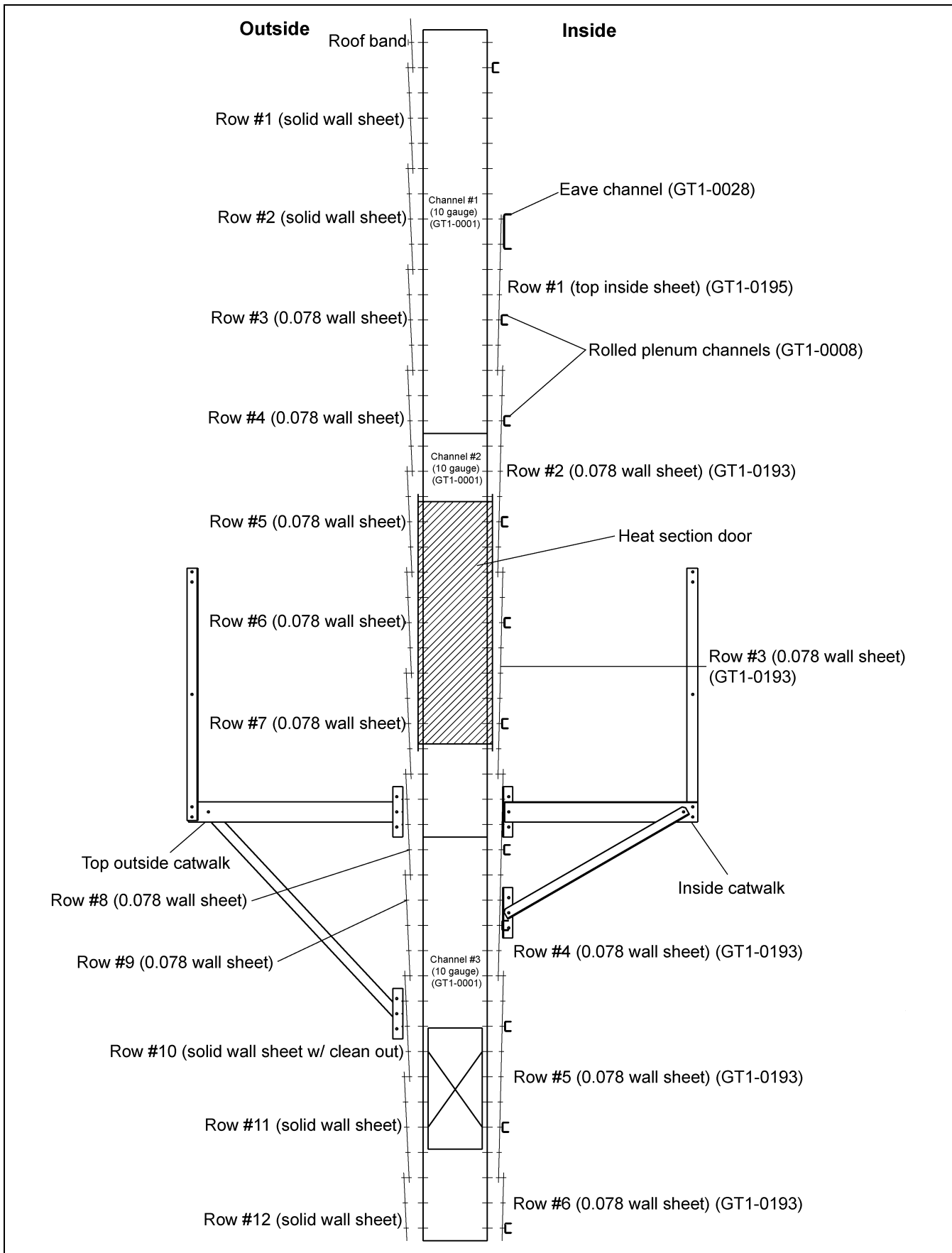

Figure 26CR Clip Placement Z-2521 Channels 1 to 3

26. All Tower Dryer Models Drawings

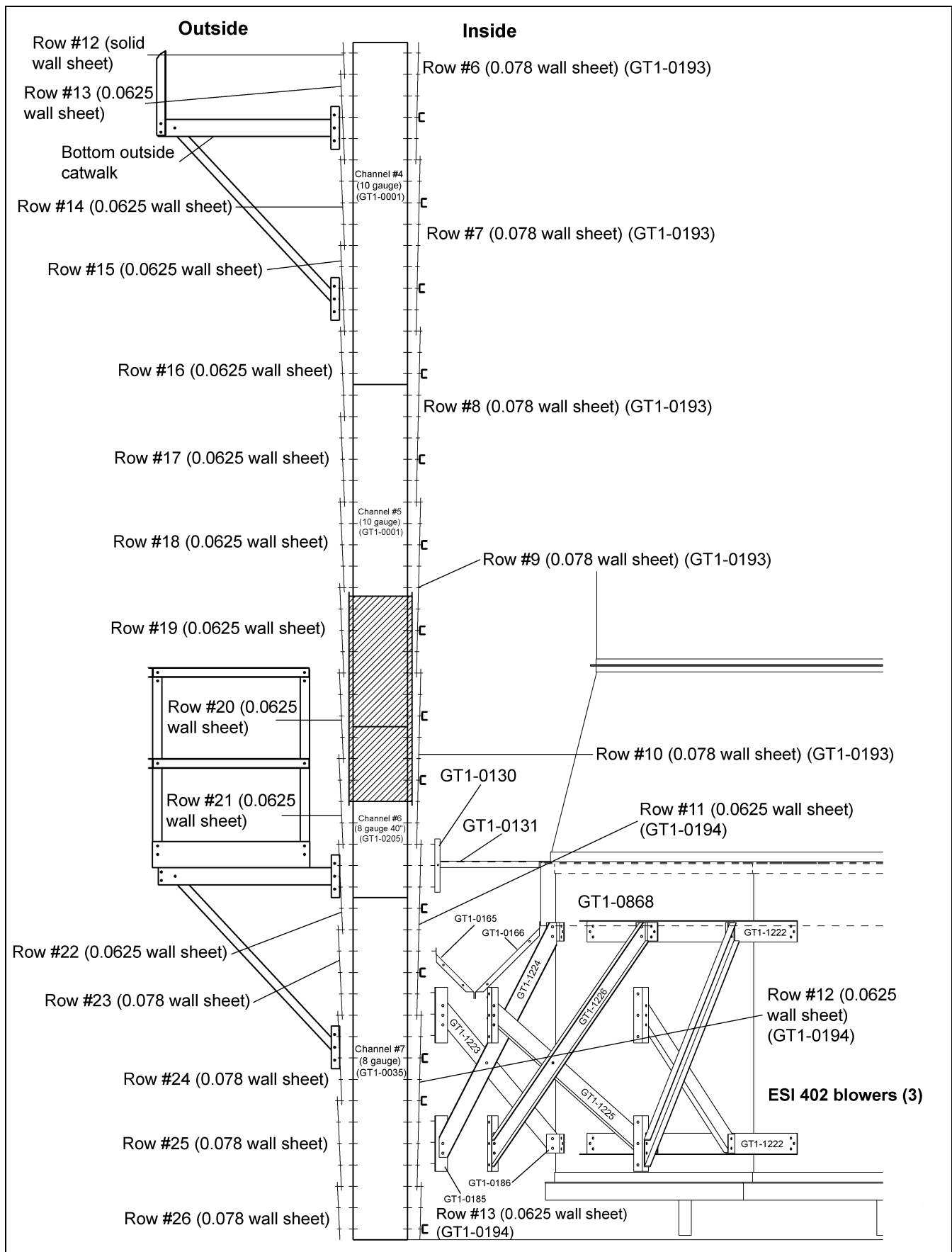

Figure 26CS Clip Placement Z-2521 Channels 4 to 7

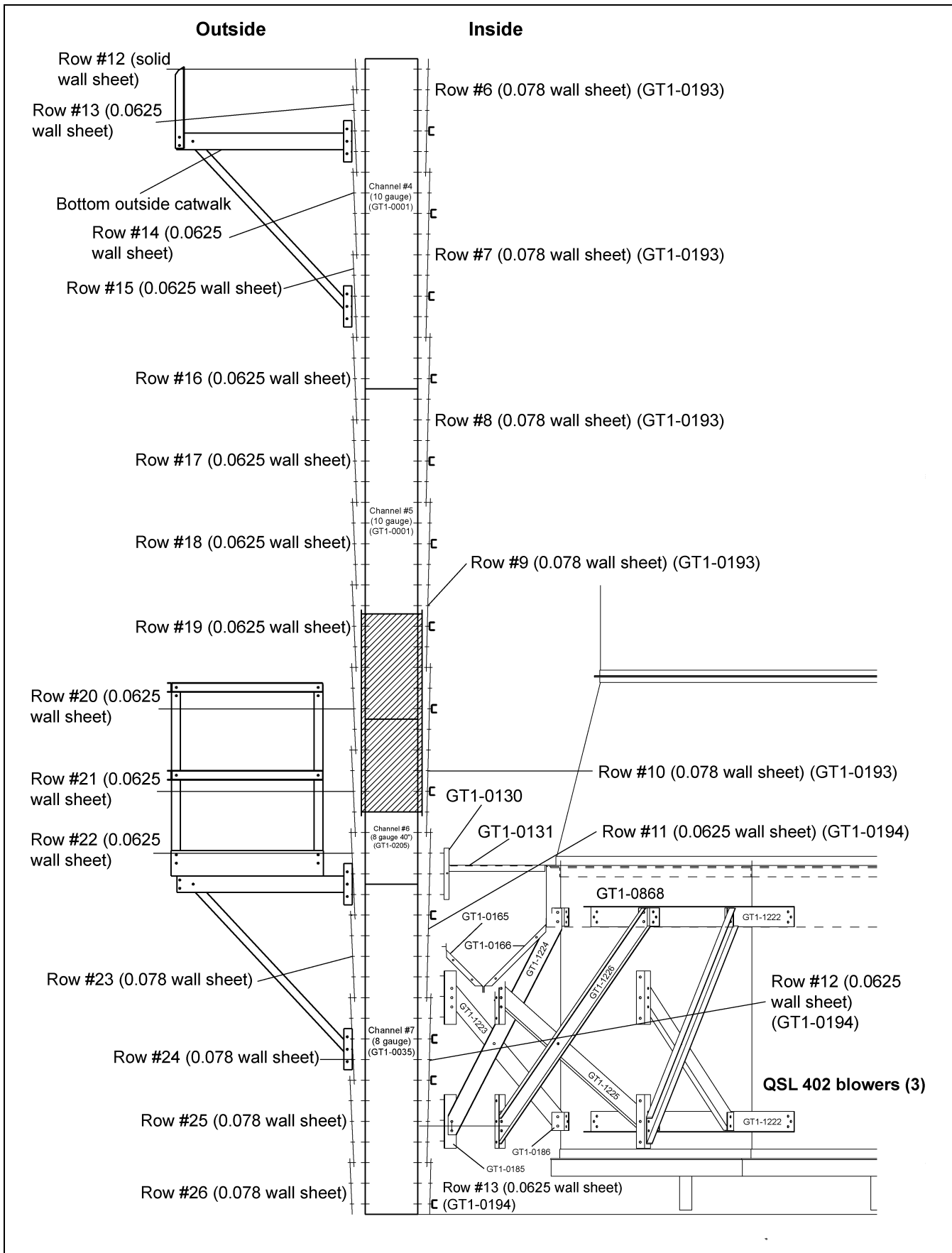

Figure 26CT Clip Placement Z-2521 QSL Blower Channels 4 to 7

26. All Tower Dryer Models Drawings

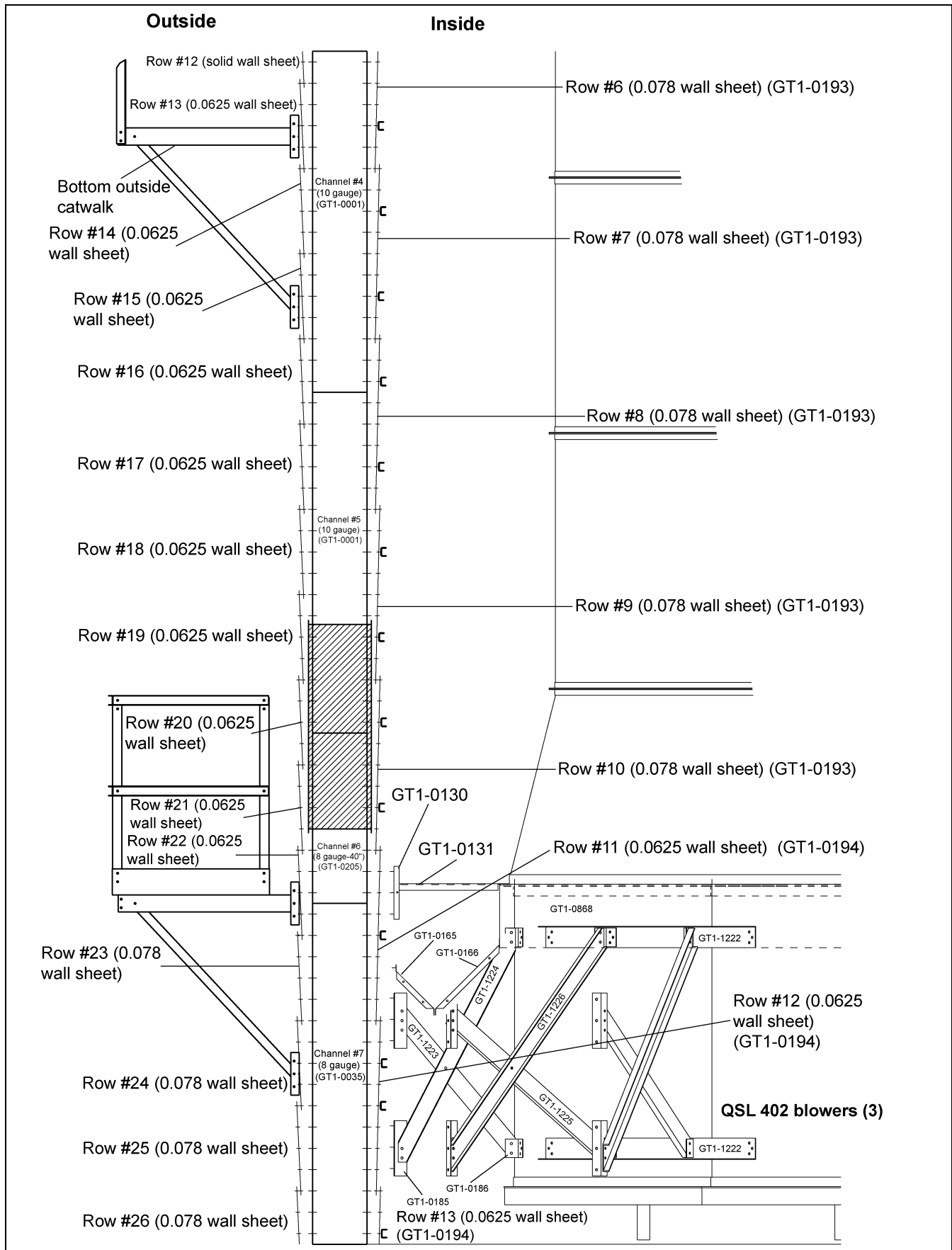

Figure 26CU Clip Placement Z-2521 QSL Blower Channels 4 to 7 (Oil)

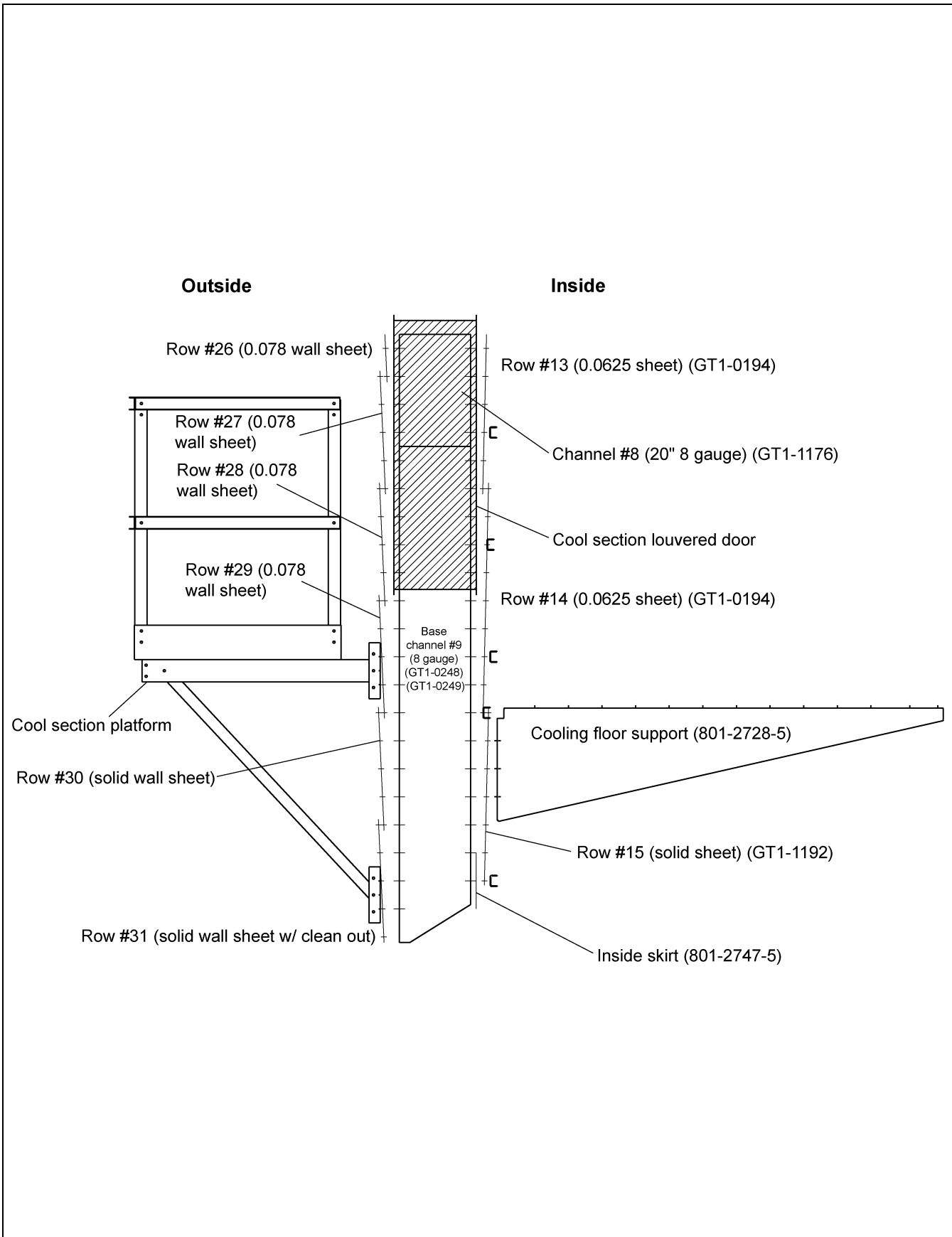

Figure 26CV Clip Placement Z-2521 Channels 8 to 9

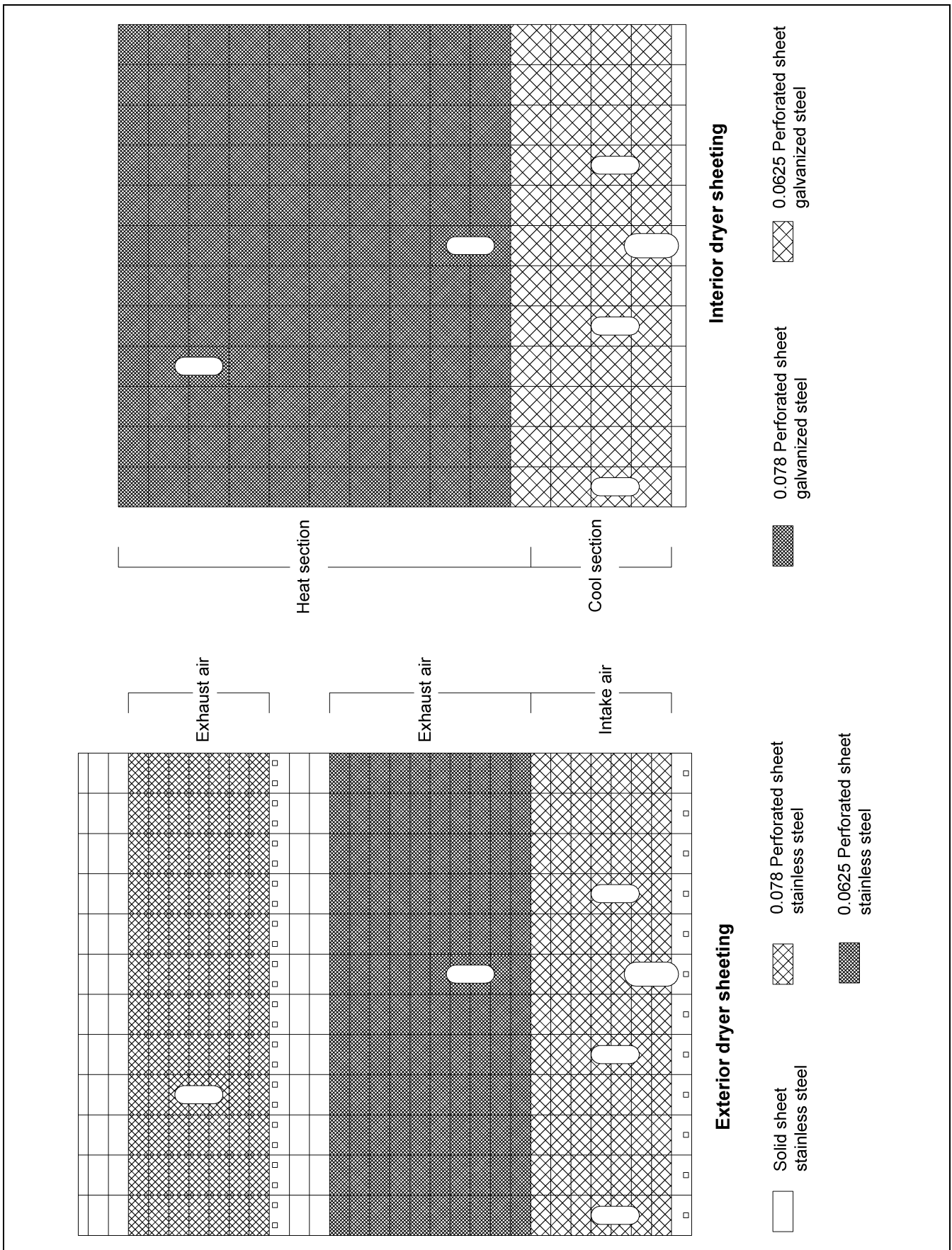

Figure 26CW Model 2521 Sheet Layout

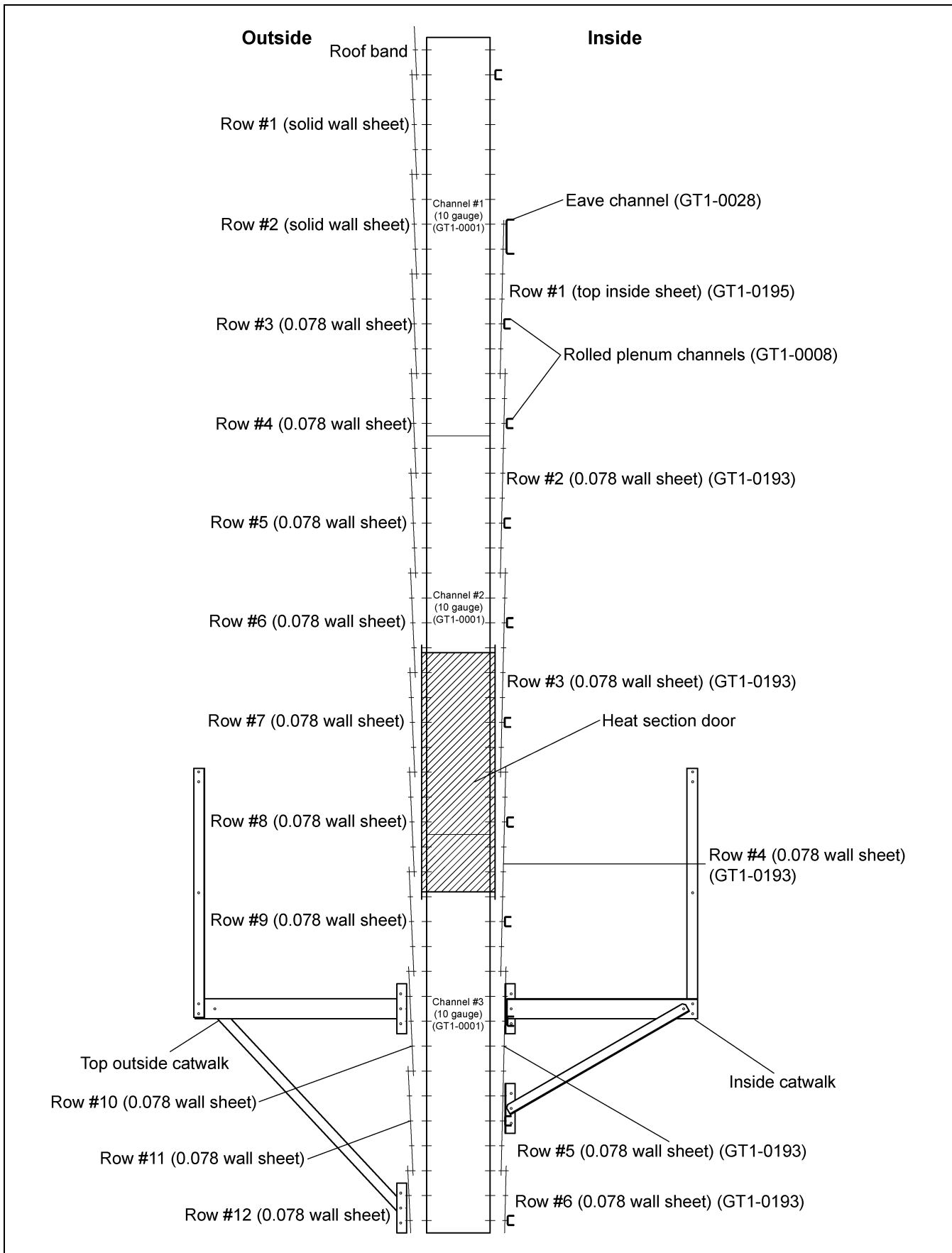

Figure 26CX Clip Placement Z-3000 Channels 1 to 3

26. All Tower Dryer Models Drawings

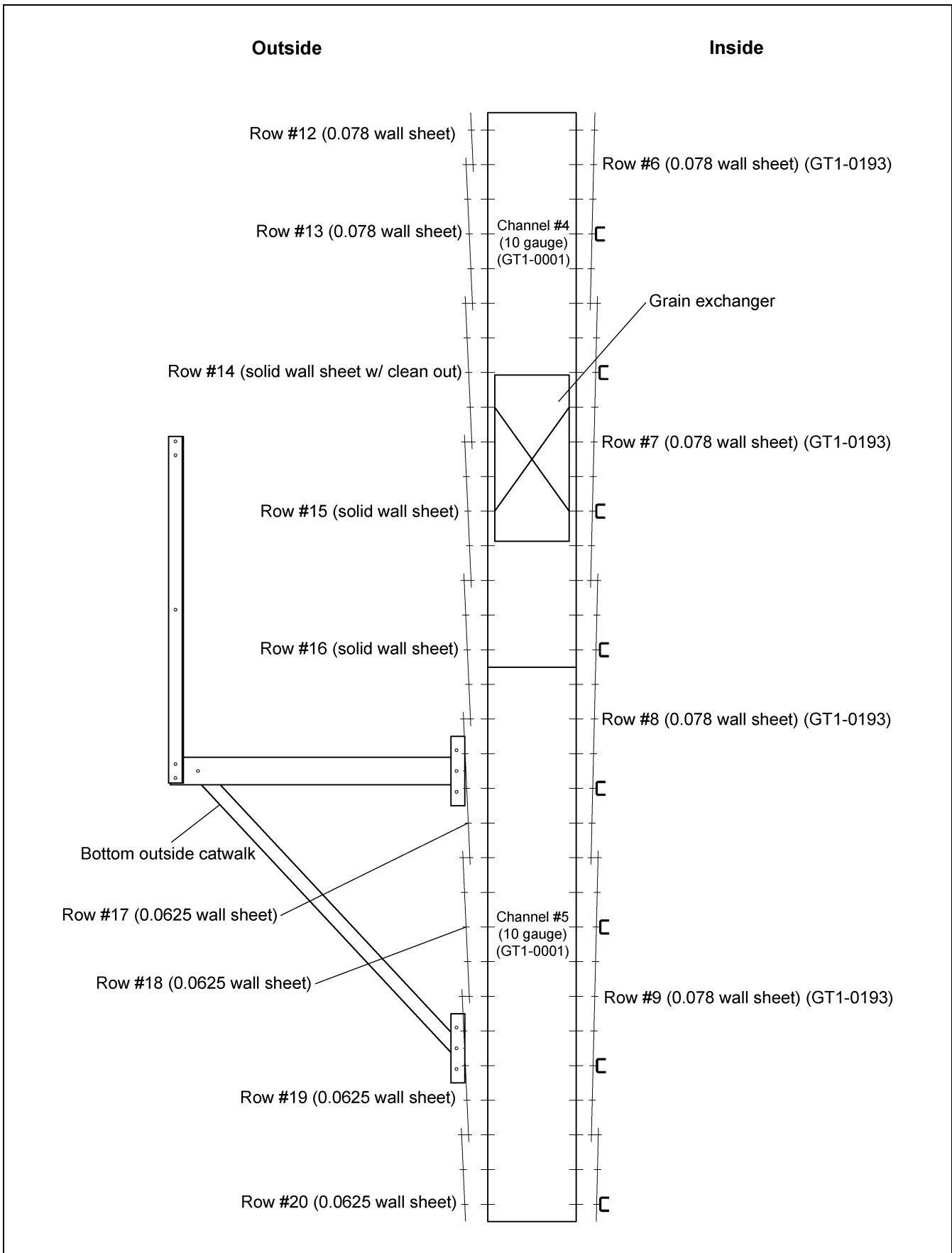

Figure 26CY Clip Placement Z-3000 Channels 4 to 5

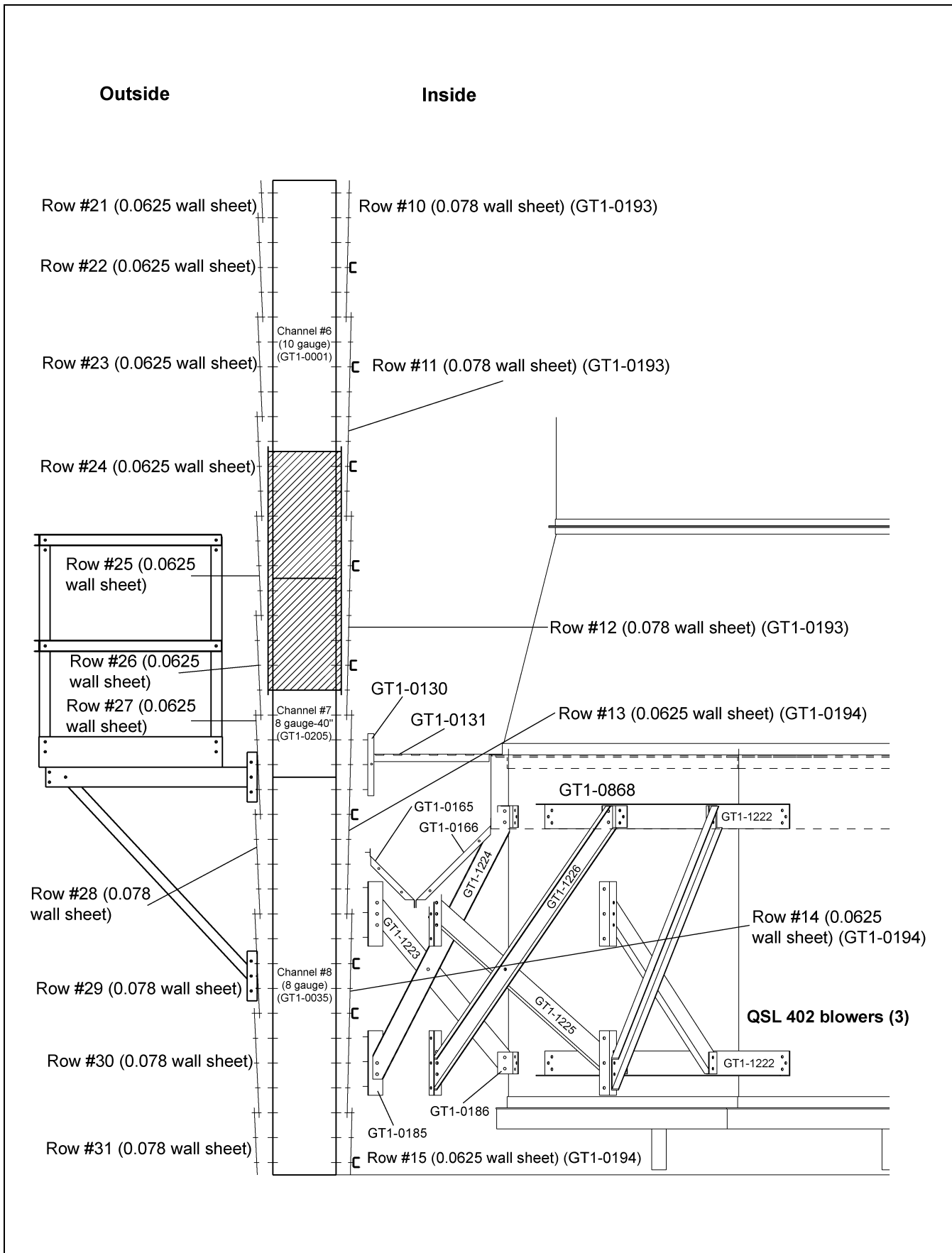

Figure 26CZ Clip Placement Z-3000 QSL Blower Channels 6 to 8

26. All Tower Dryer Models Drawings

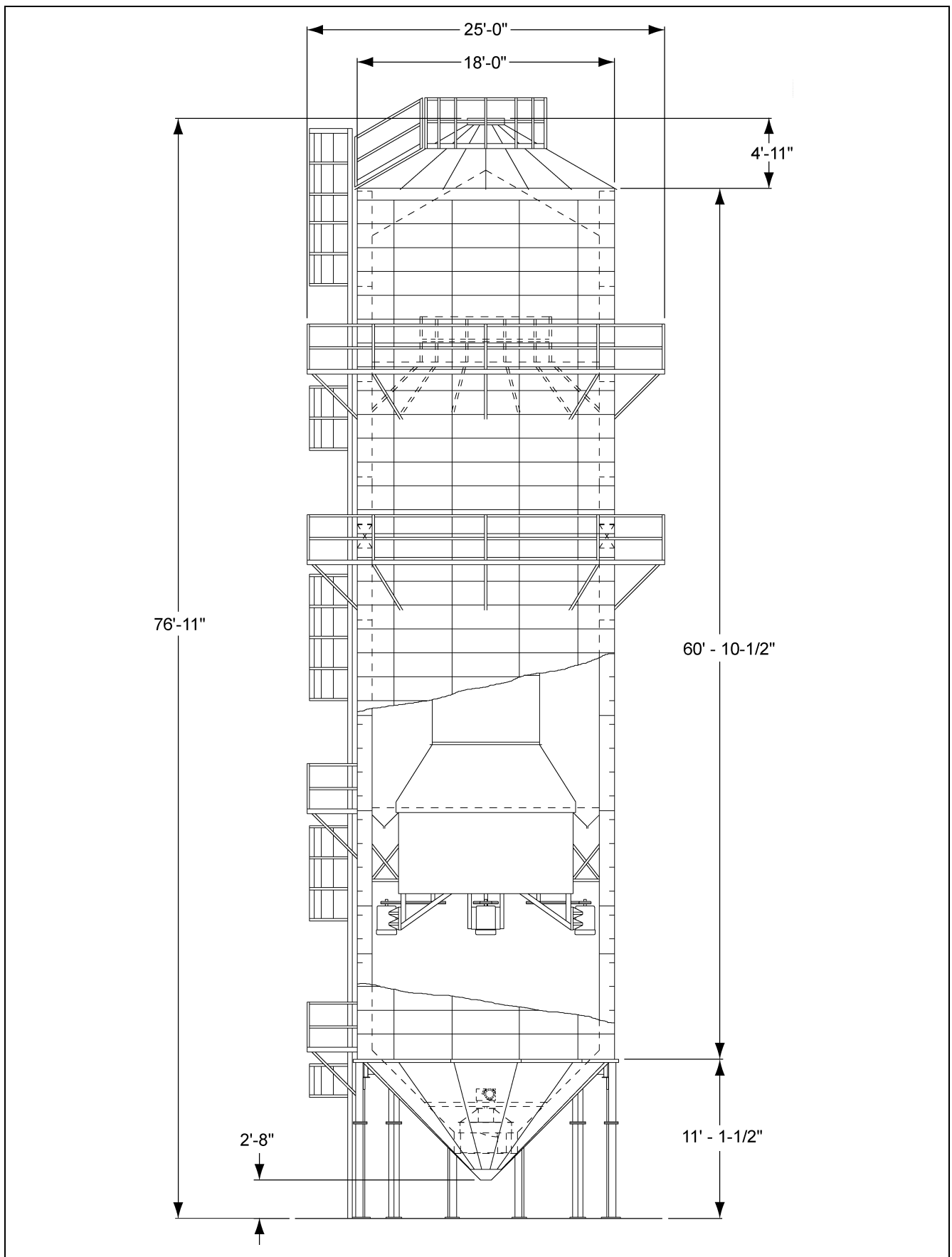

Figure 26DA GSI Tower Dryer Model 3000

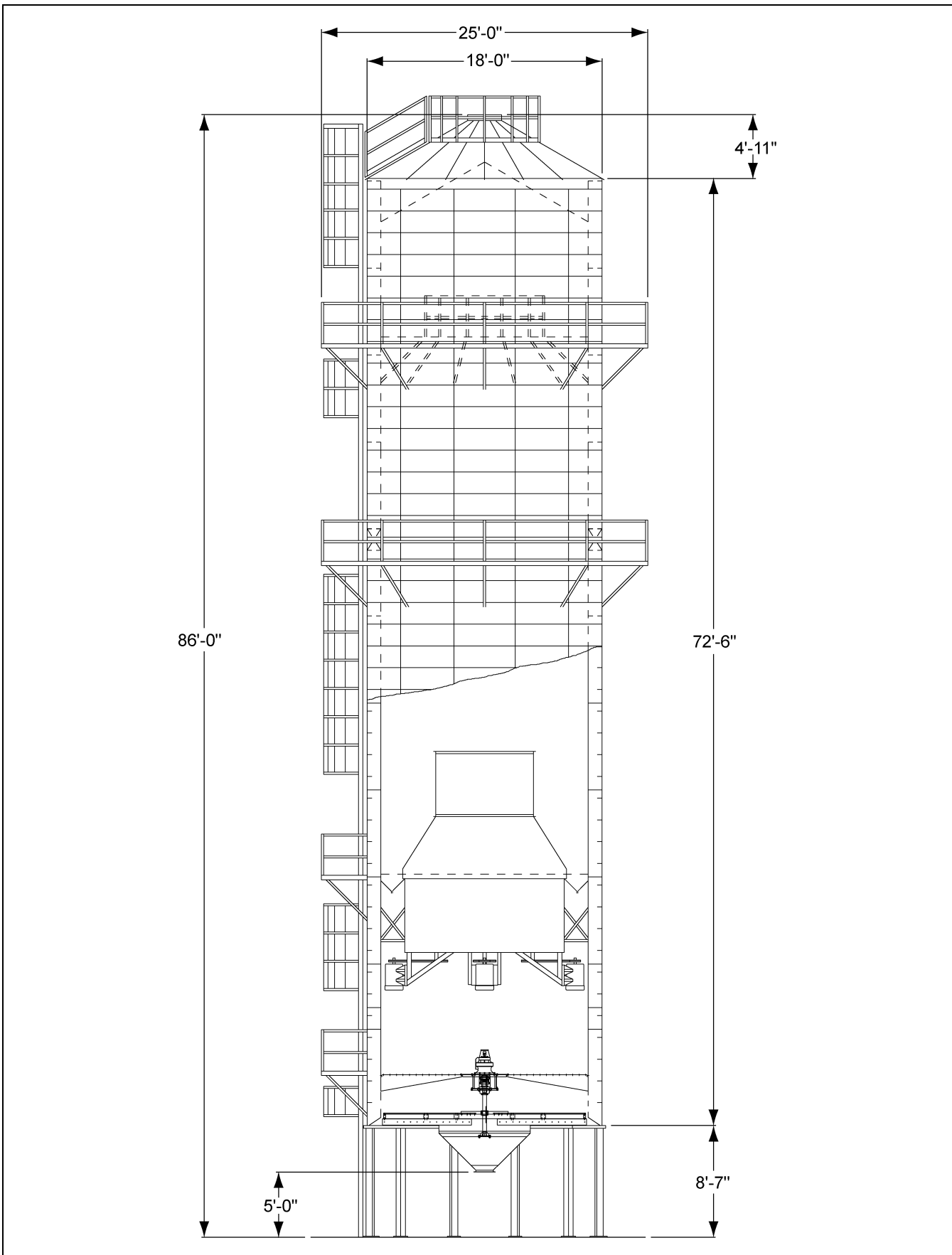

Figure 26DB Zimmerman Tower Dryer Model Z-3531

26. All Tower Dryer Models Drawings

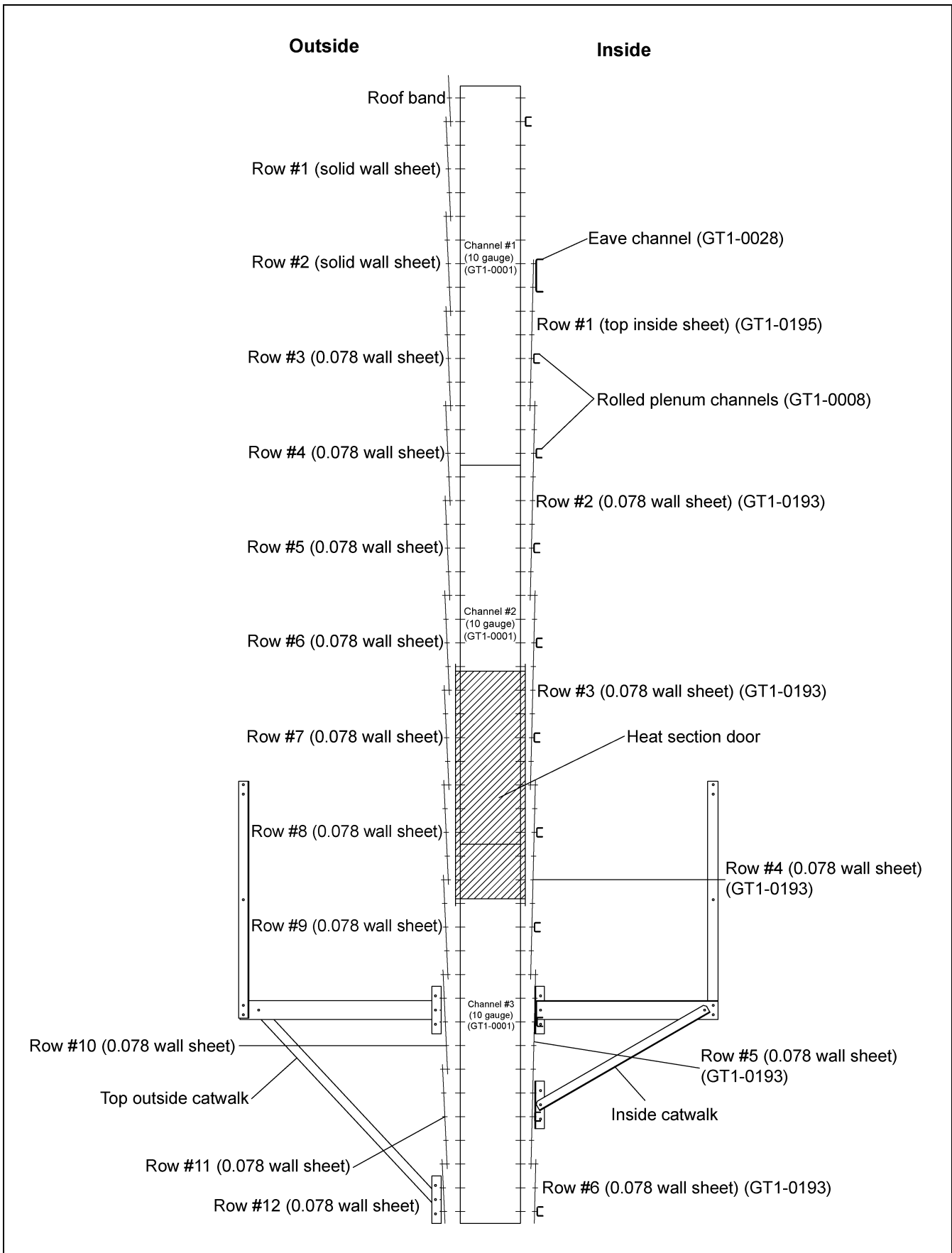

Figure 26DC Clip Placement Z-3026 Channels 1 to 3

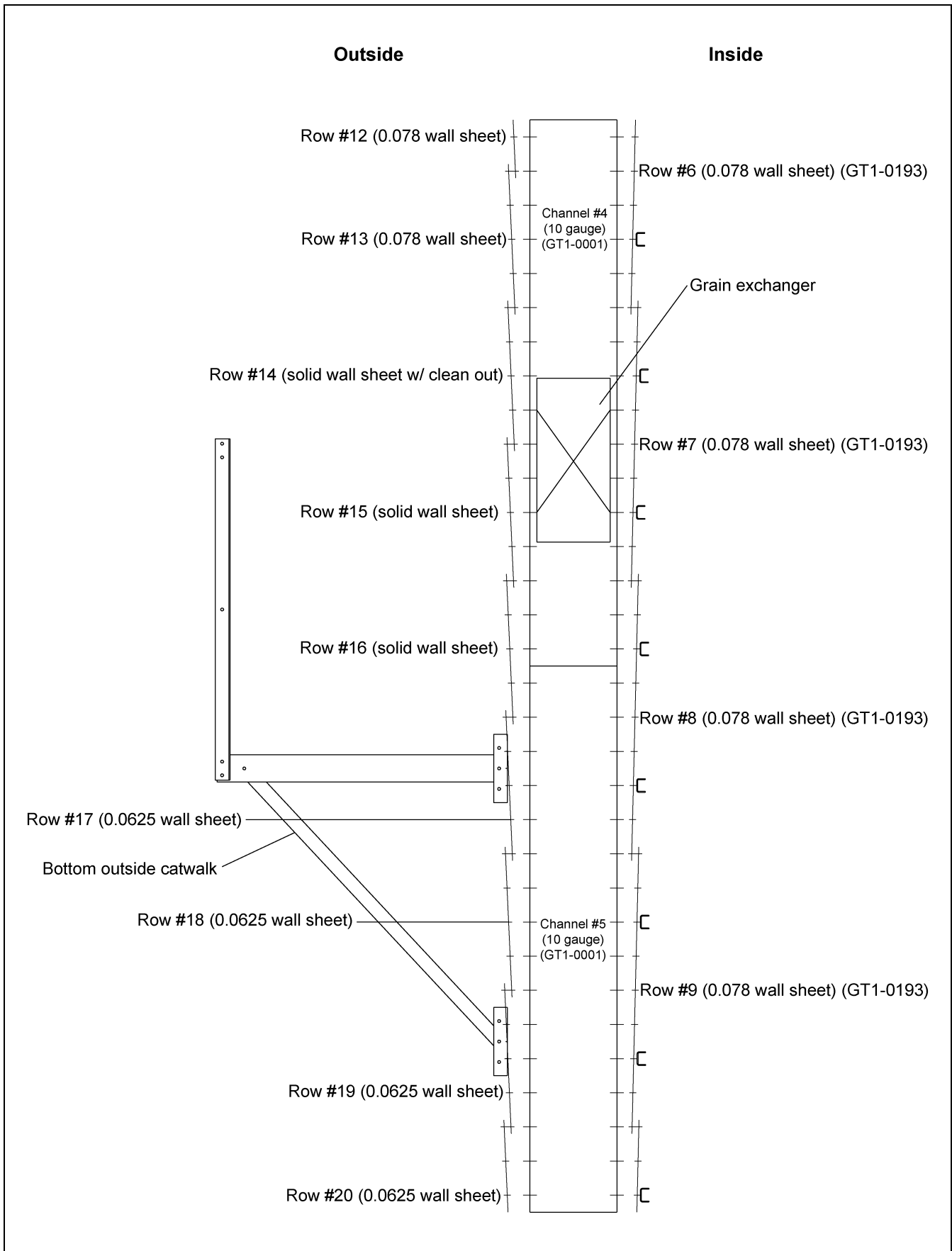

Figure 26DD Clip Placement Z-3026 Channels 4 to 5

26. All Tower Dryer Models Drawings

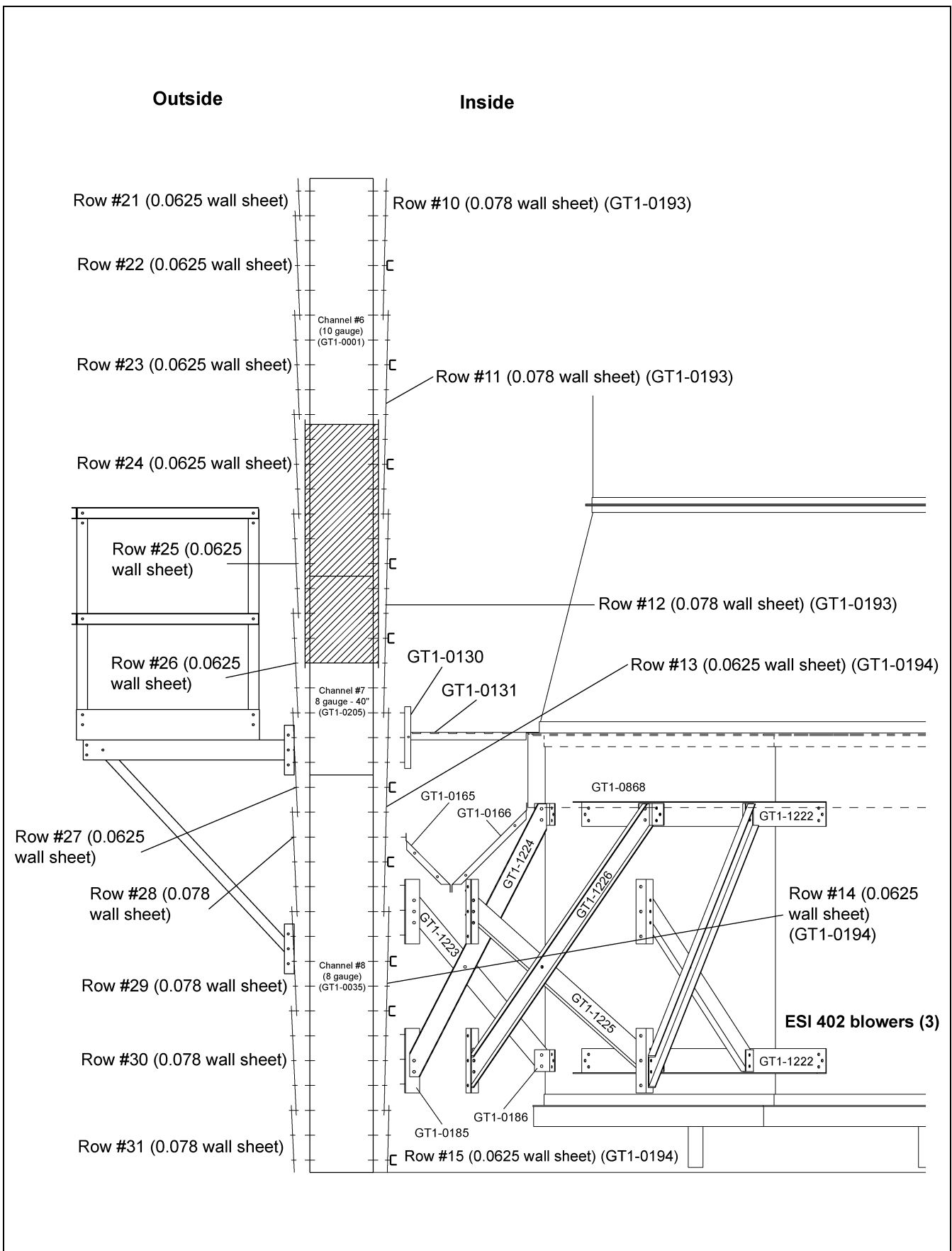

Figure 26DE Clip Placement Z-3026 Channels 6 to 8

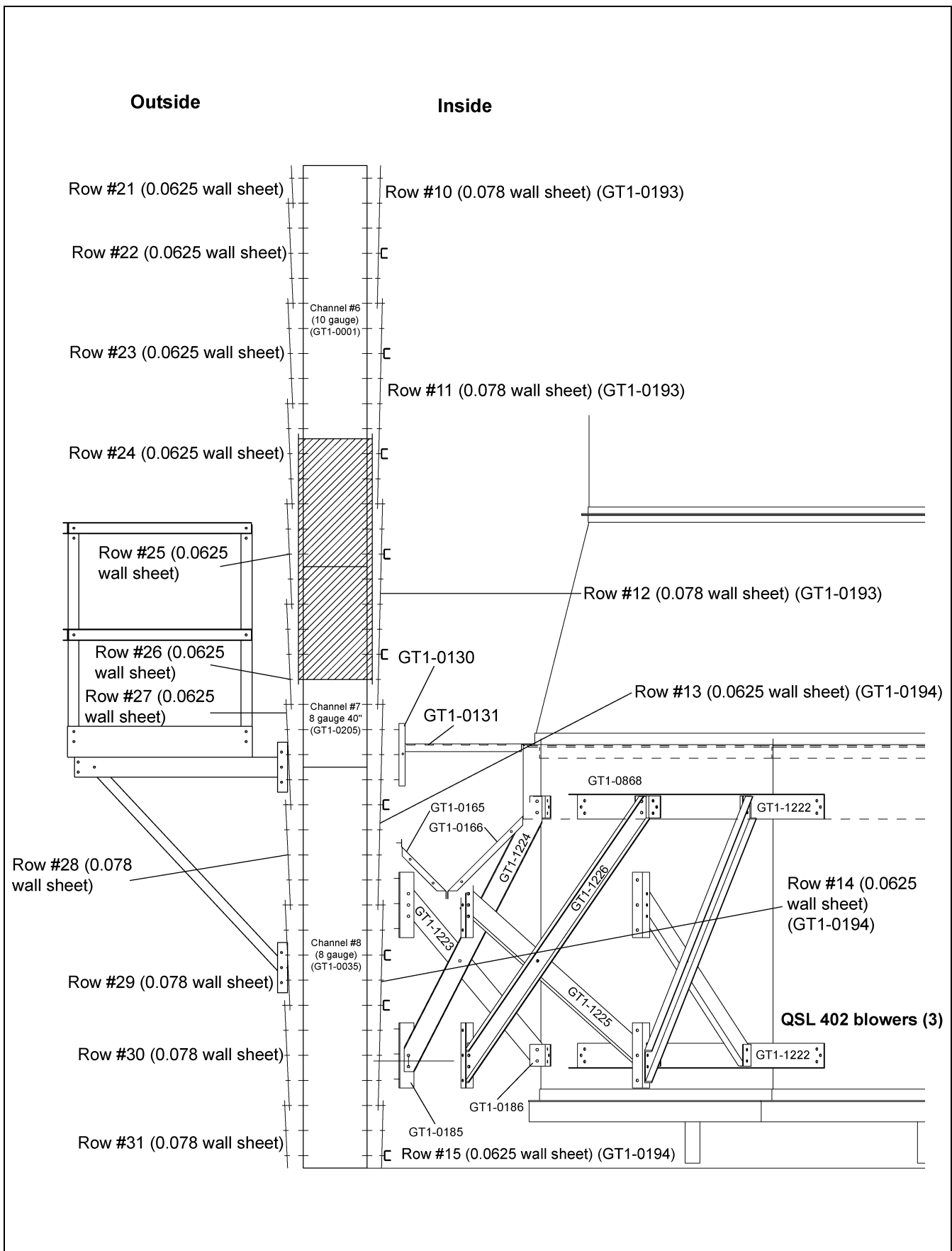

Figure 26DF Clip Placement Z-3026 QSL Blower Channels 6 to 8

26. All Tower Dryer Models Drawings

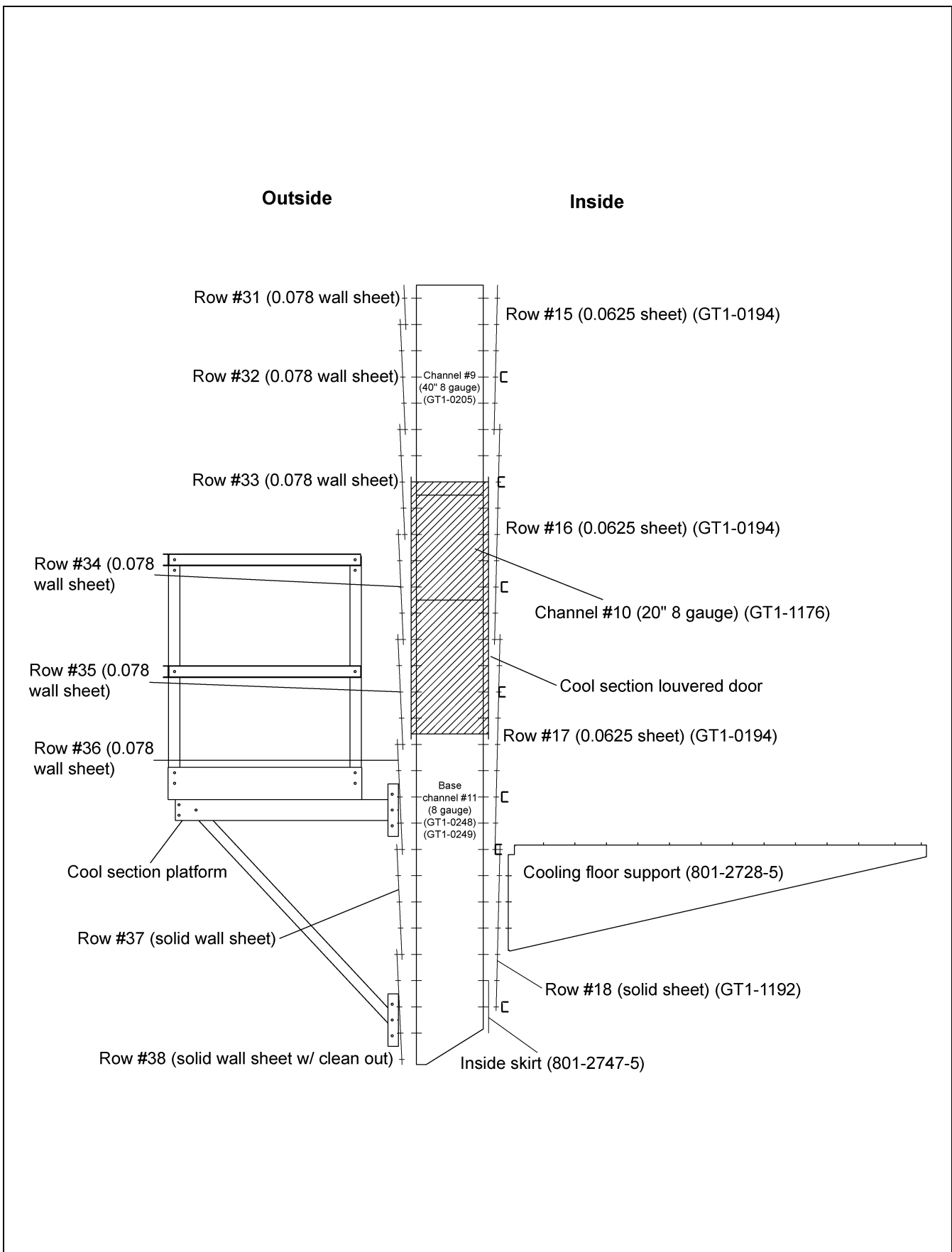

Figure 26DG Clip Placement Z-3026 Channels 9 to 11

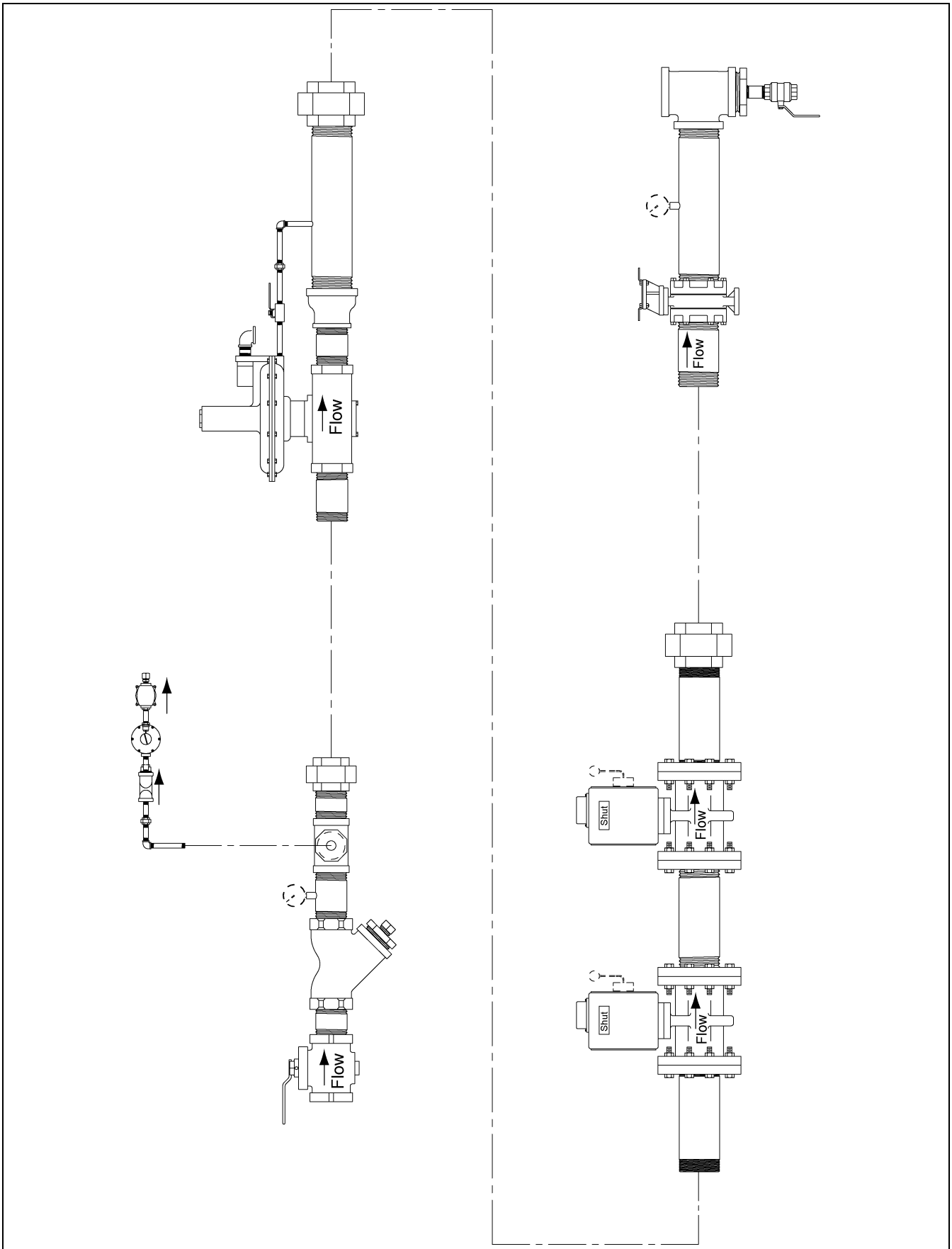

Figure 26DH Complete 4" Gas Train - Domestic

26. All Tower Dryer Models Drawings

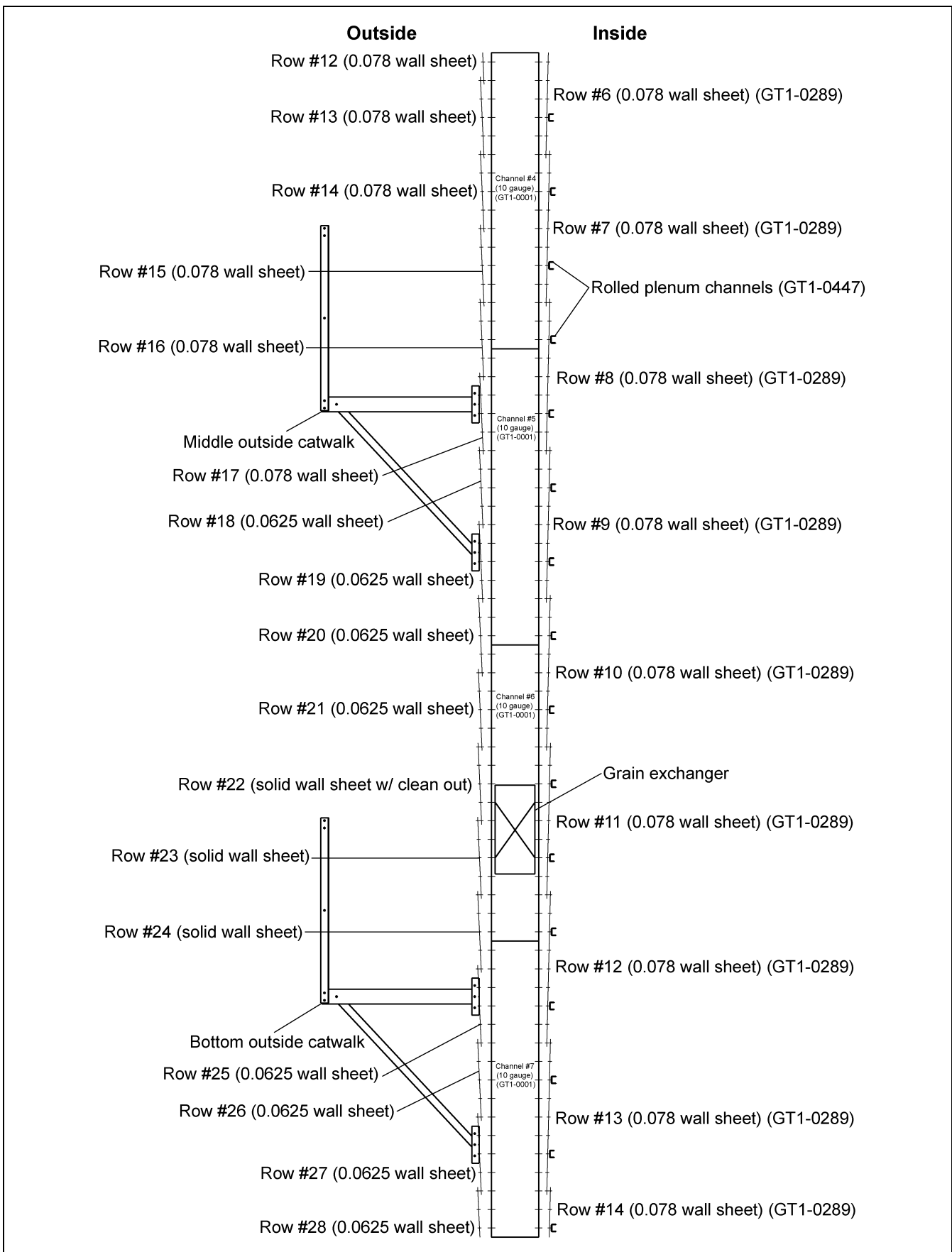

Figure 26DI Clip Placement Z-5046 Channels 4 to 7 (3 Catwalk Dryer)

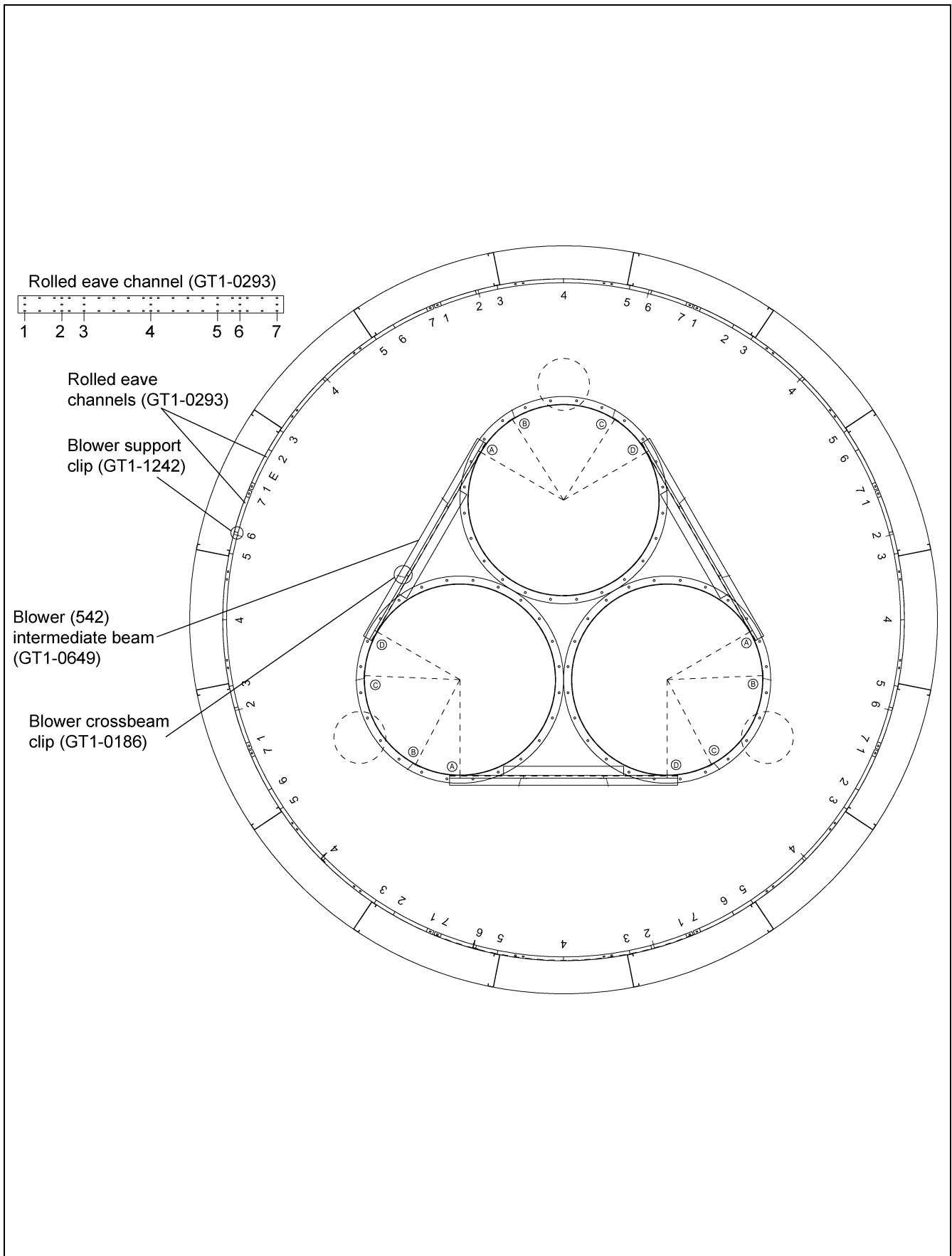

Figure 26DJ 542 Blower Attachment Clip Location - 24' Dryers

26. All Tower Dryer Models Drawings

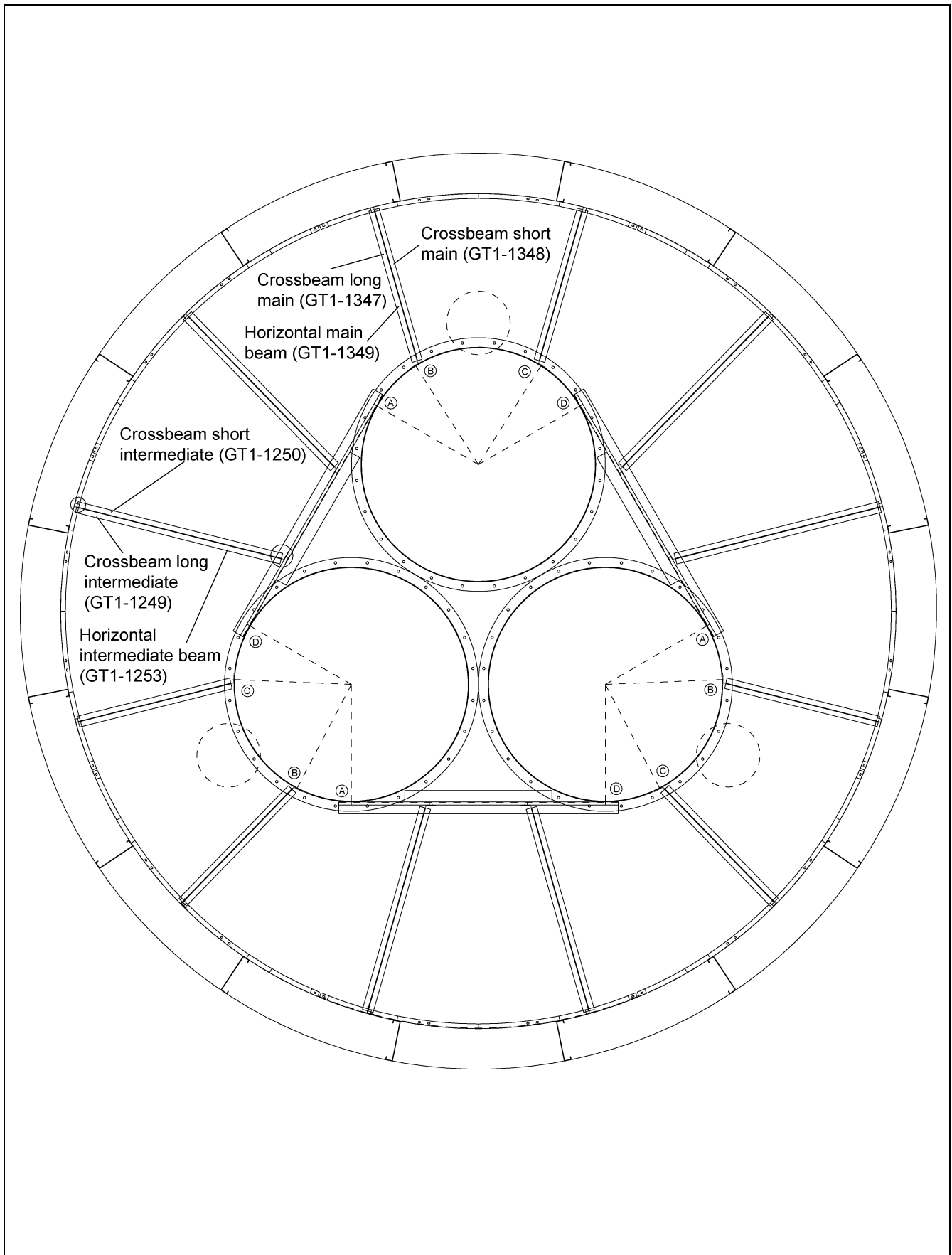

Figure 26DK 542 Blower Attachment X-Bracing - 24' Dryers

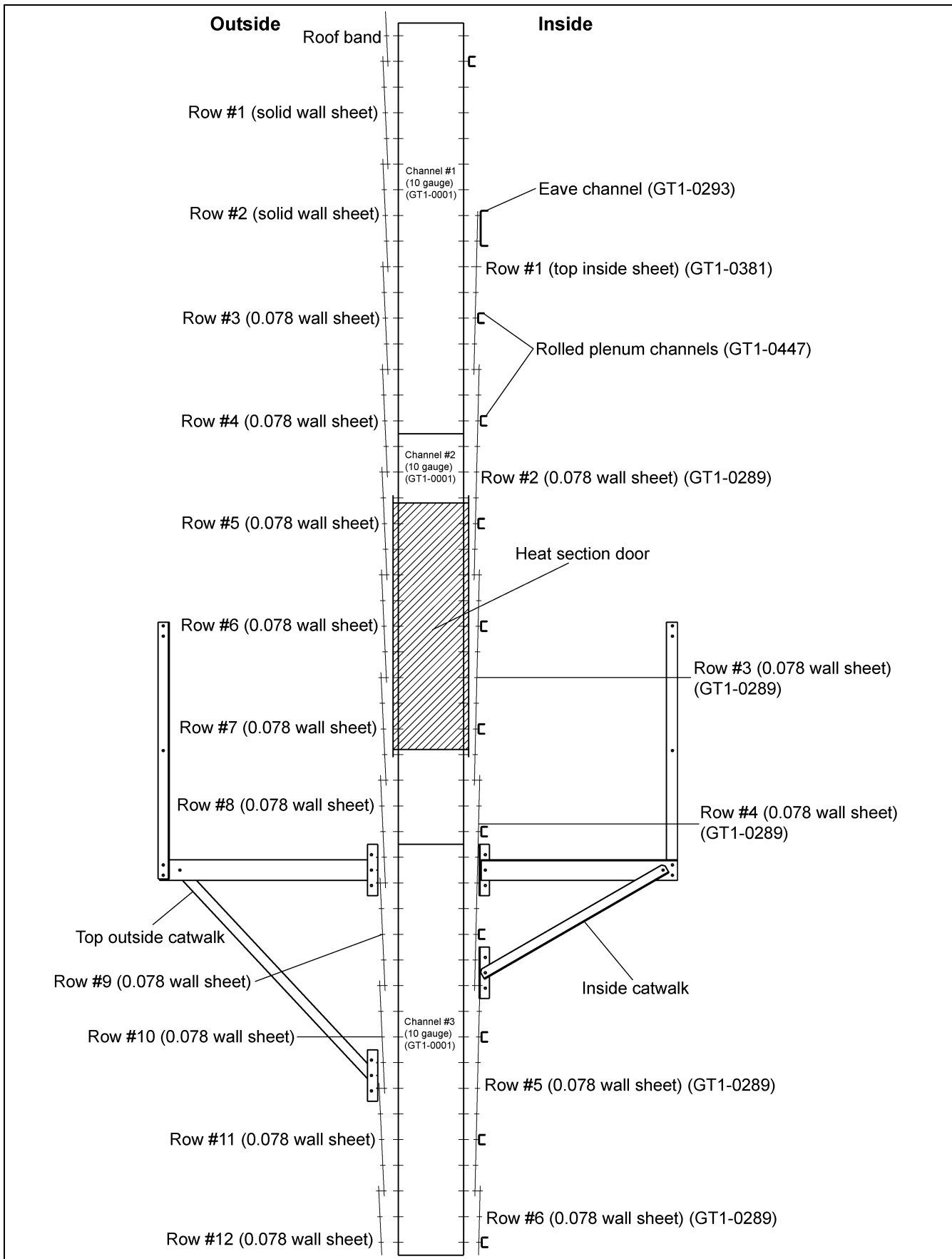

Figure 26DL Clip Placement Z-5046 Channels 1 to 3

26. All Tower Dryer Models Drawings

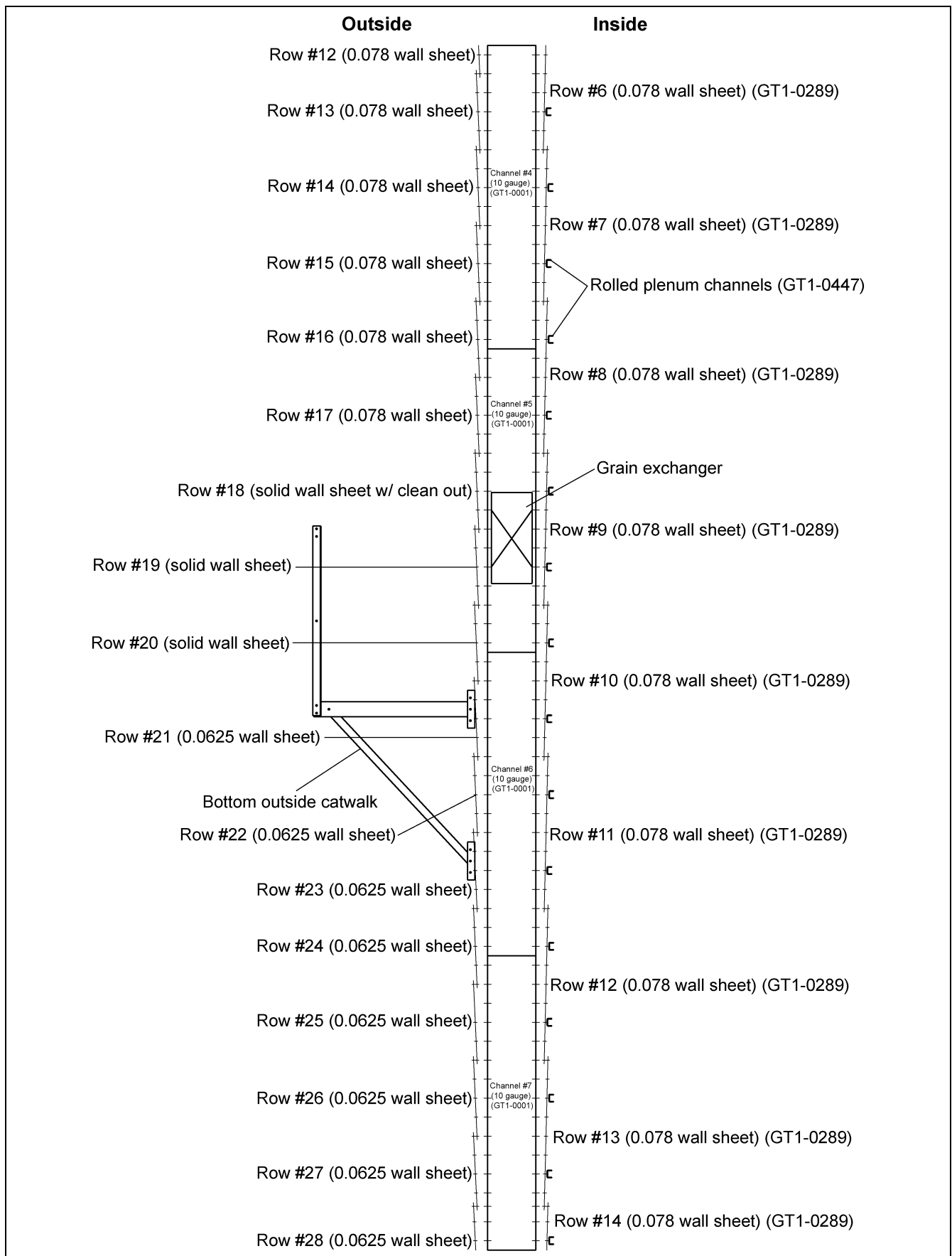

Figure 26DM Clip Placement Z-5046 Channels 4 to 7

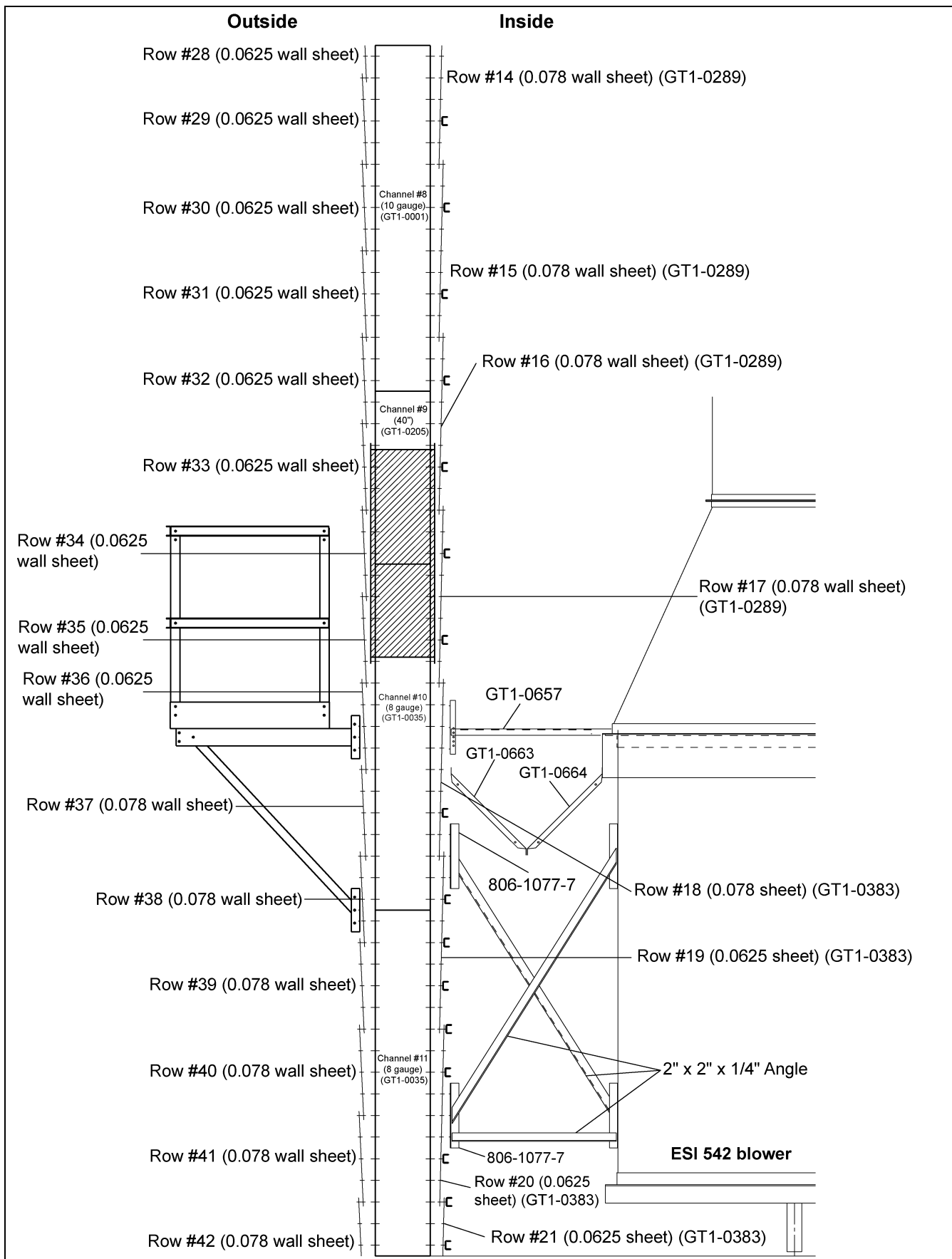

Figure 26DN Clip Placement Z-5046 Channels 8 to 11

26. All Tower Dryer Models Drawings

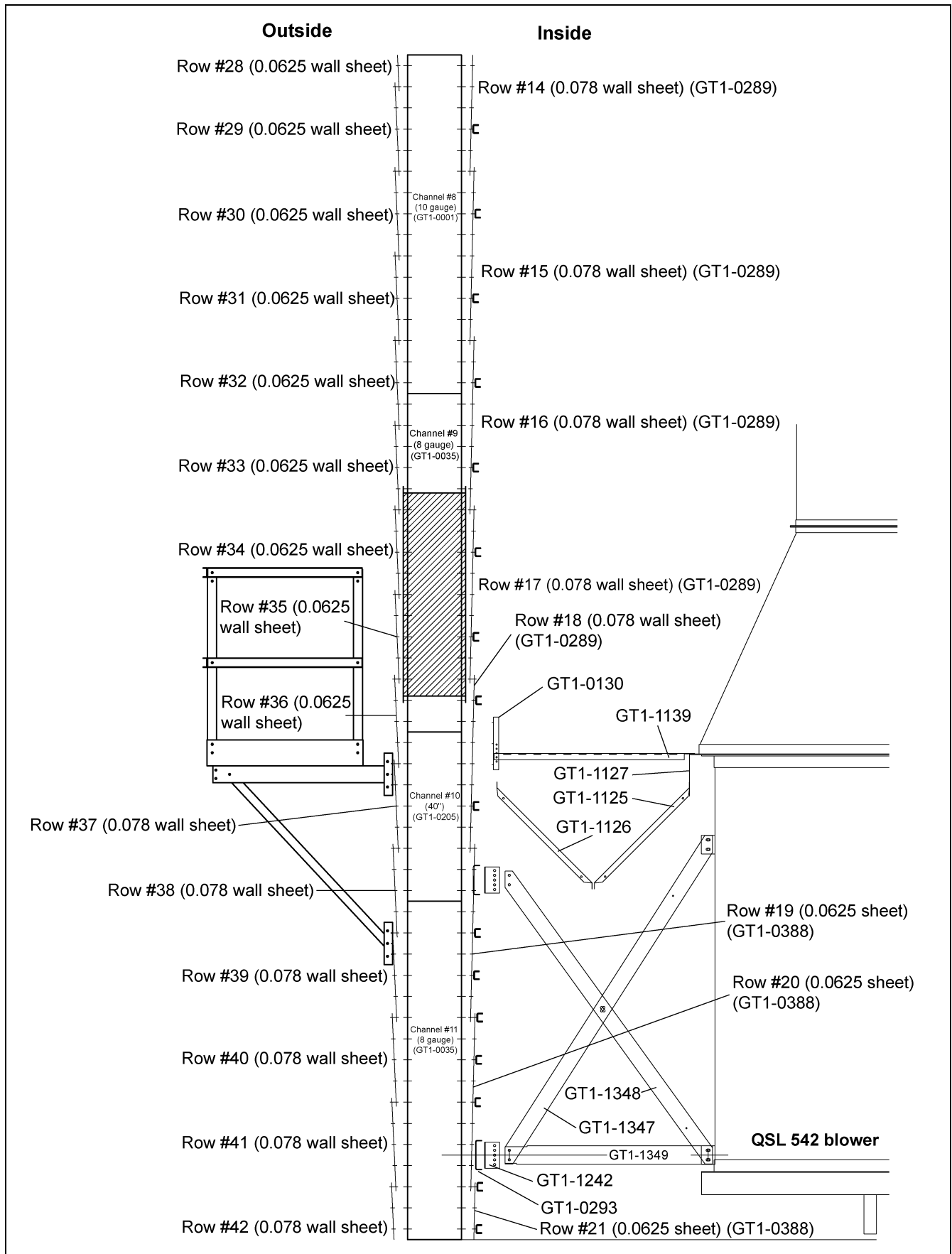

Figure 26DO Clip Placement Z-5046 w/ QSL Blowers Channels 8 to 11

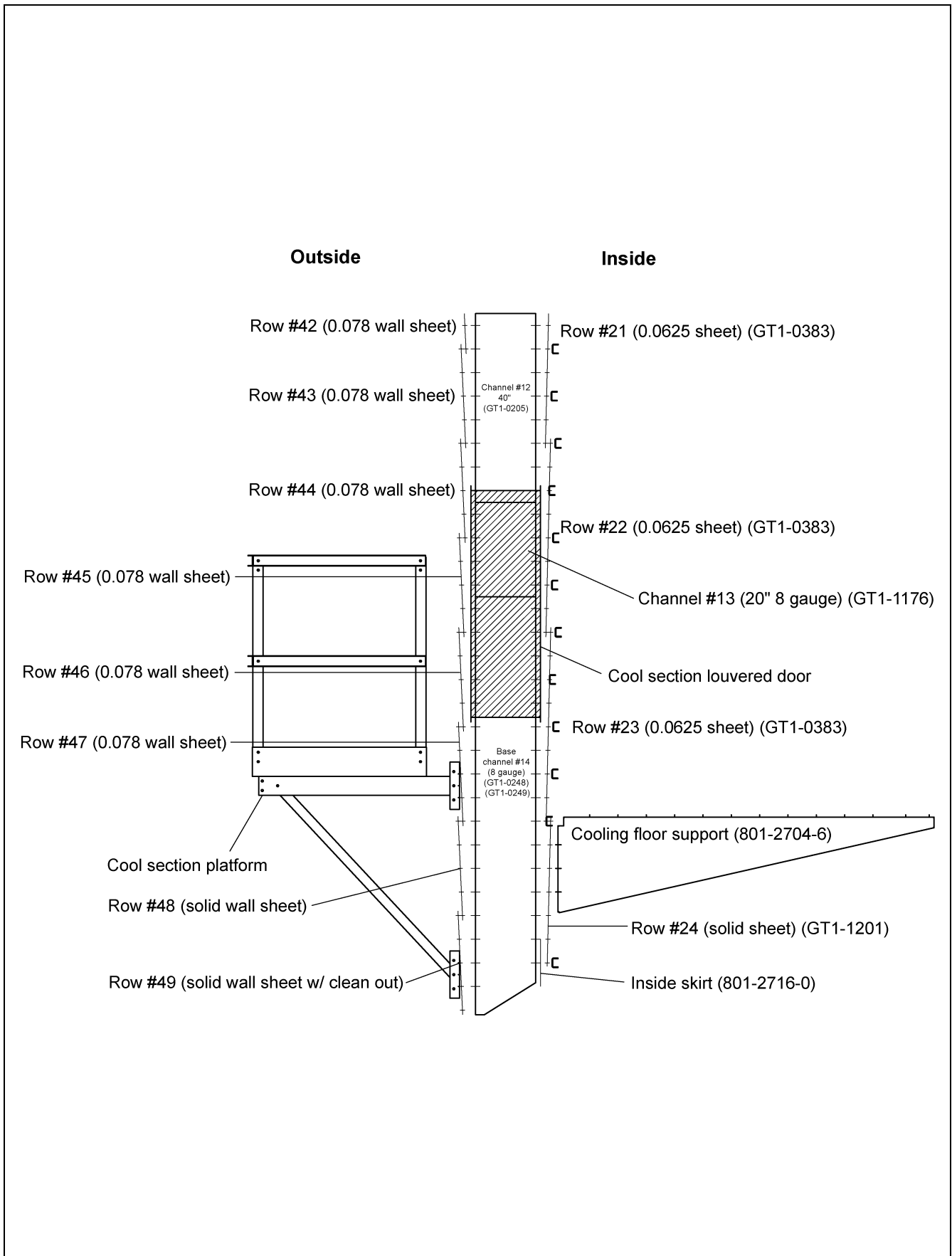

Figure 26DP Clip Placement Z-5046 Channels 12 to 14

26. All Tower Dryer Models Drawings

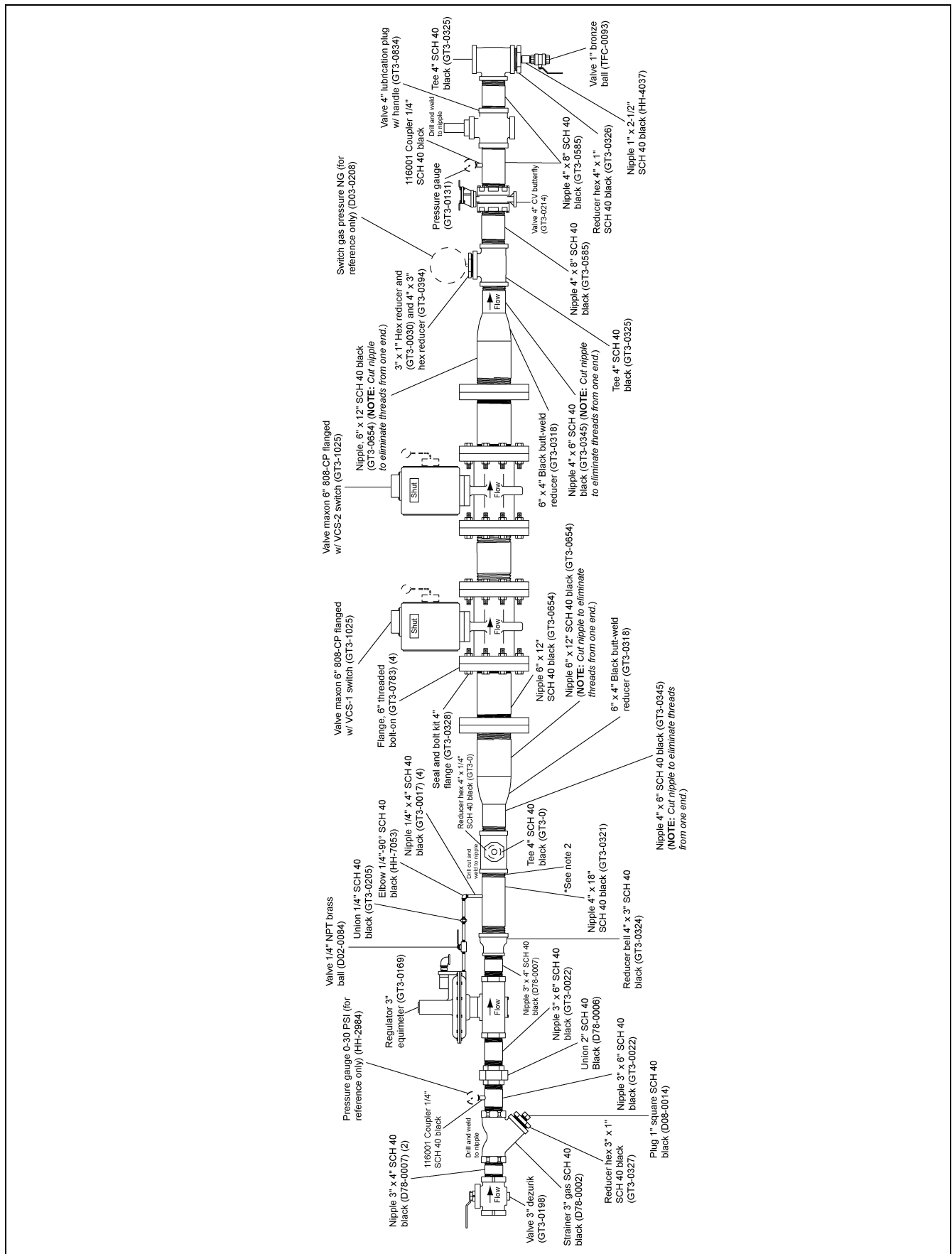

Figure 26DQ 10000 BPH 6" Fuel Train

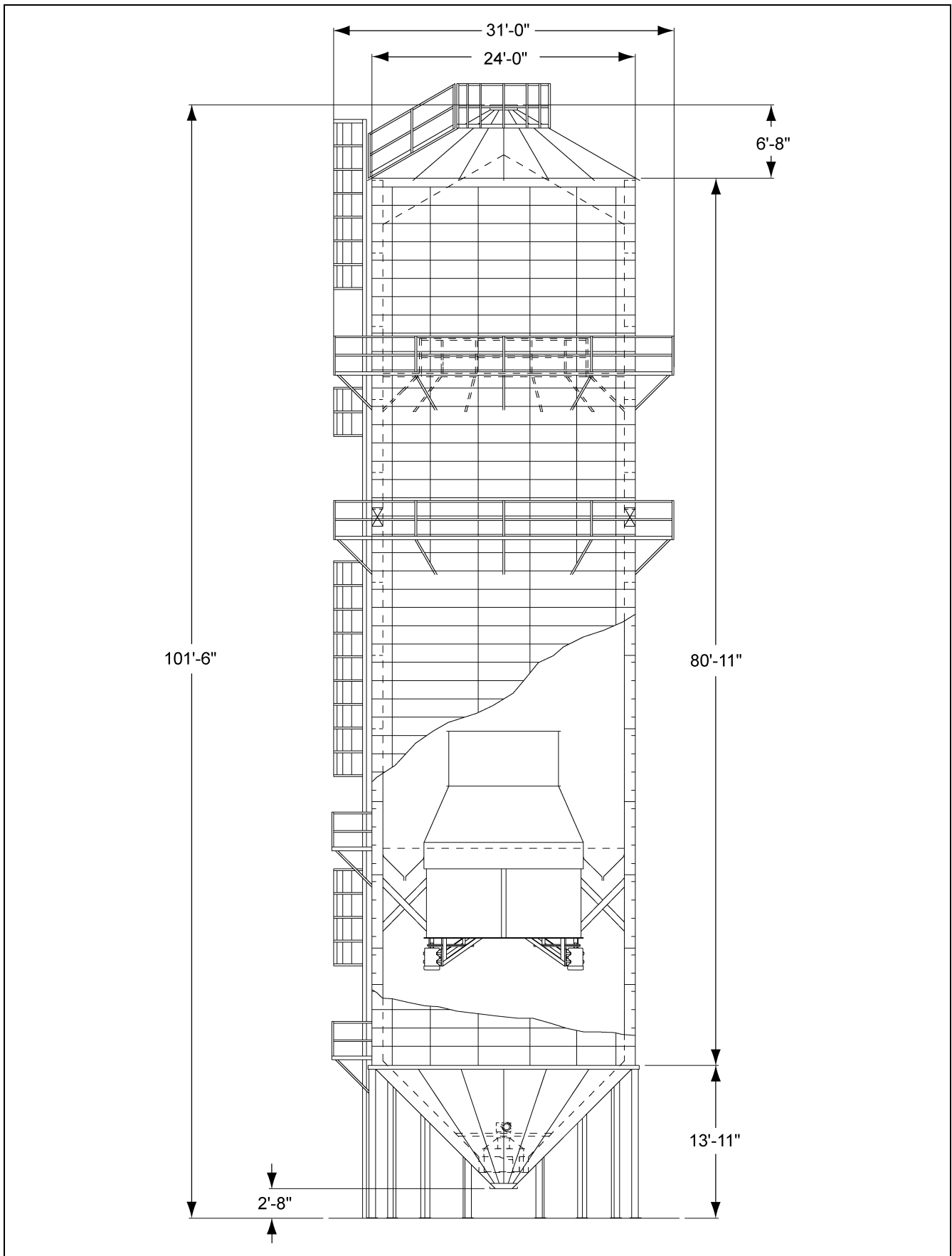

Figure 26DR GSI Tower Dryer Model 5000

26. All Tower Dryer Models Drawings

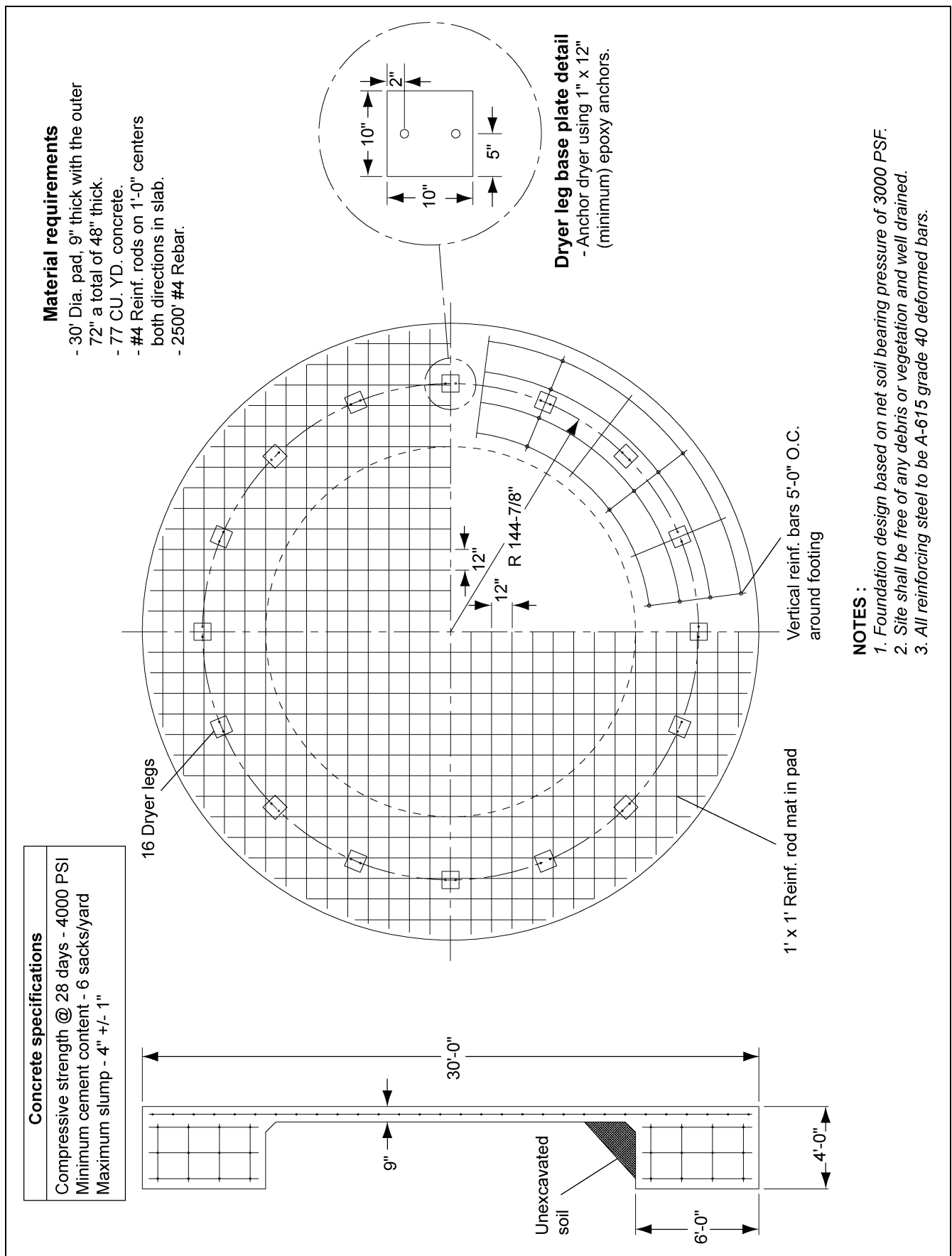

Figure 26DS Foundation Plan 24' Tower Dryers

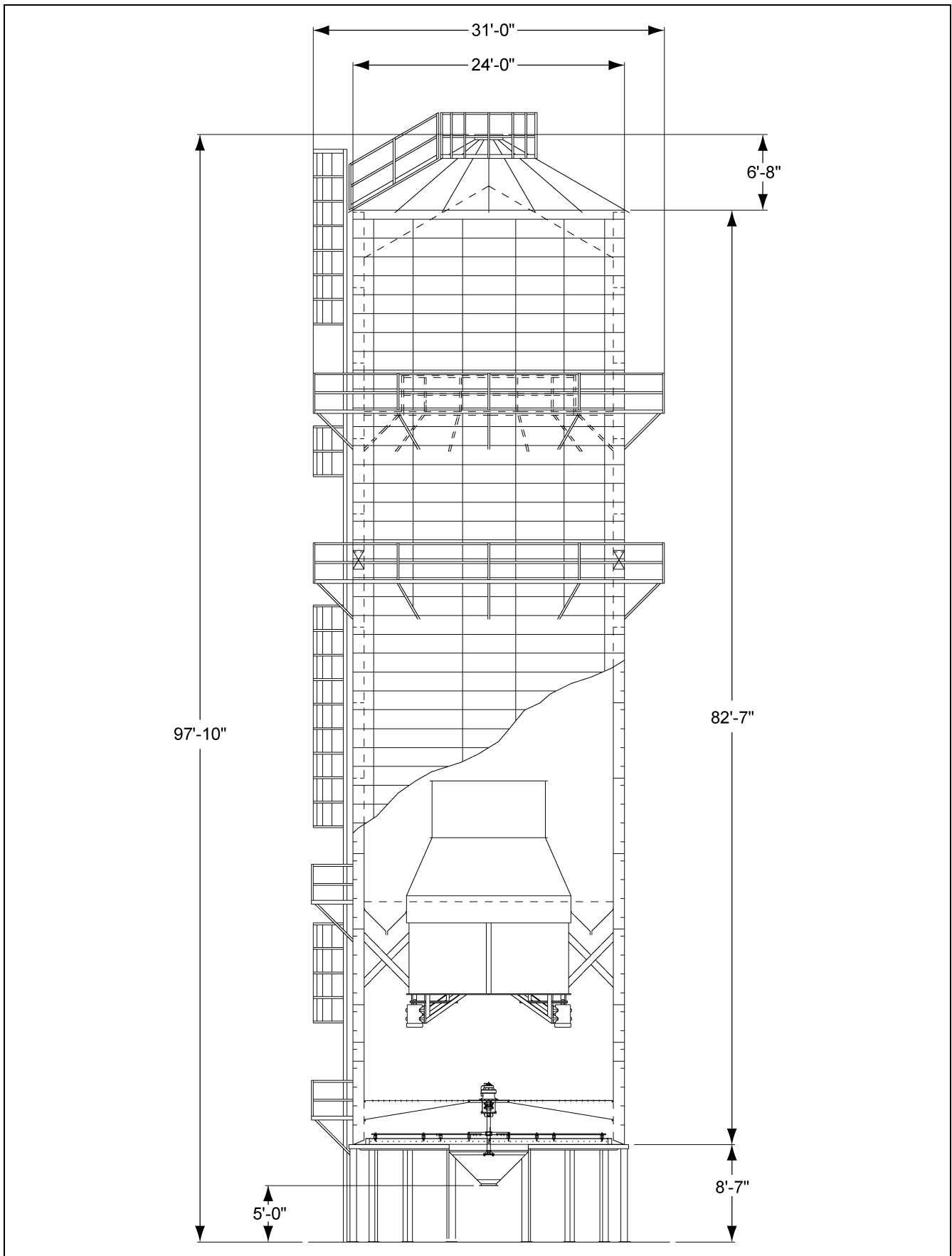

Figure 26DT Zimmerman Tower Dryer Model Z-5046

26. All Tower Dryer Models Drawings

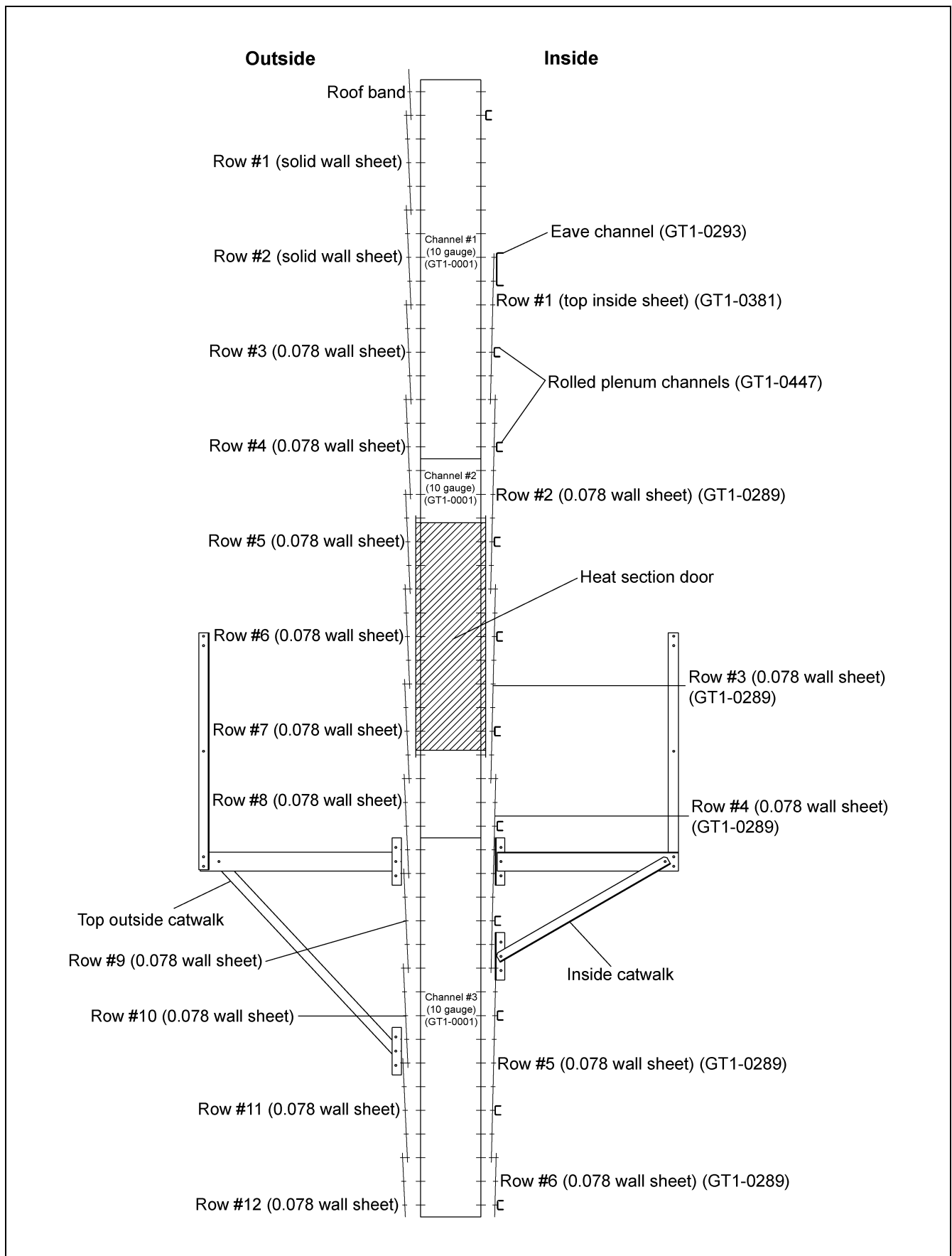

Figure 26DU Clip Placement Z-7060 Channels 1 to 3

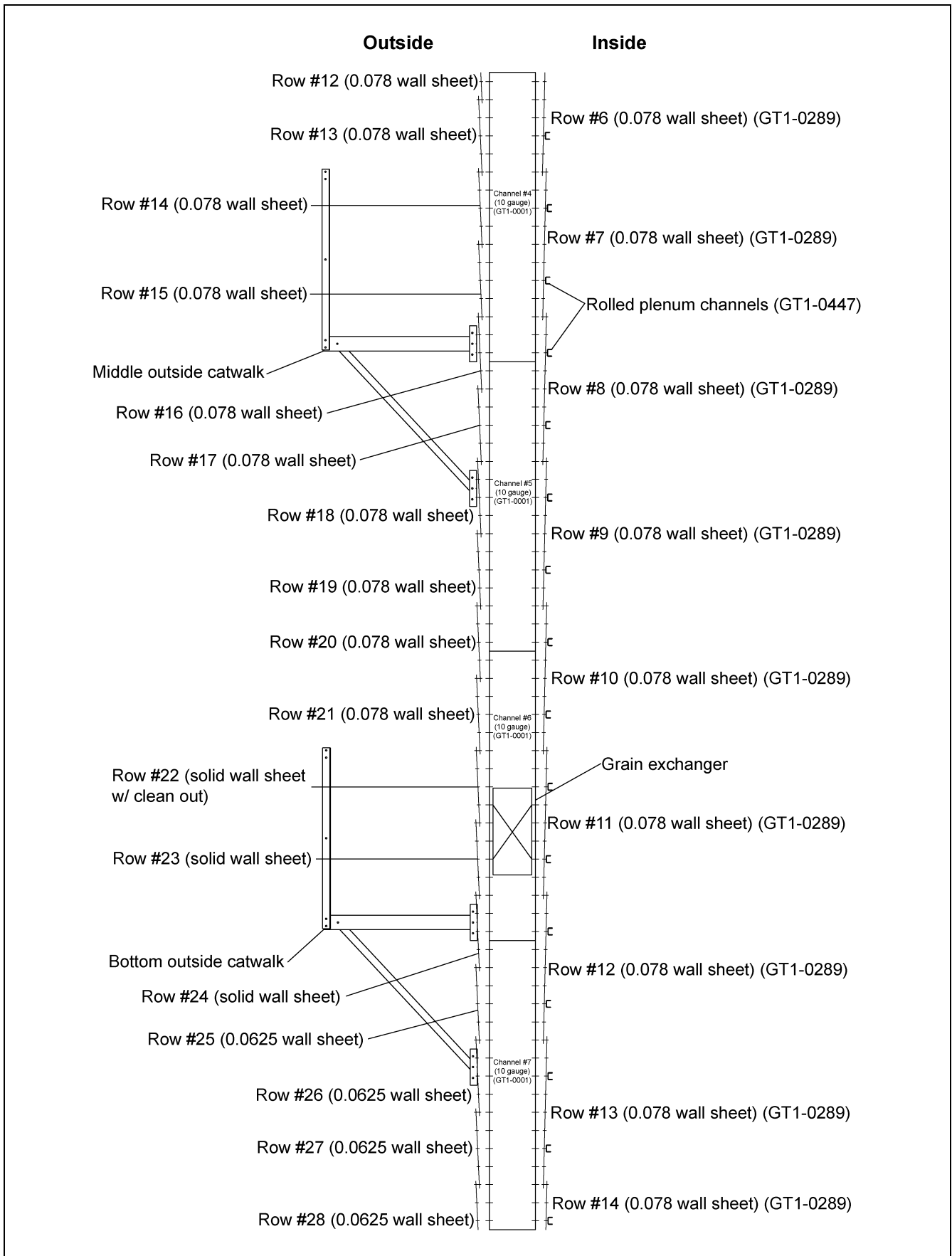

Figure 26DV Clip Placement Z-7060 Channels 4 to 7

26. All Tower Dryer Models Drawings

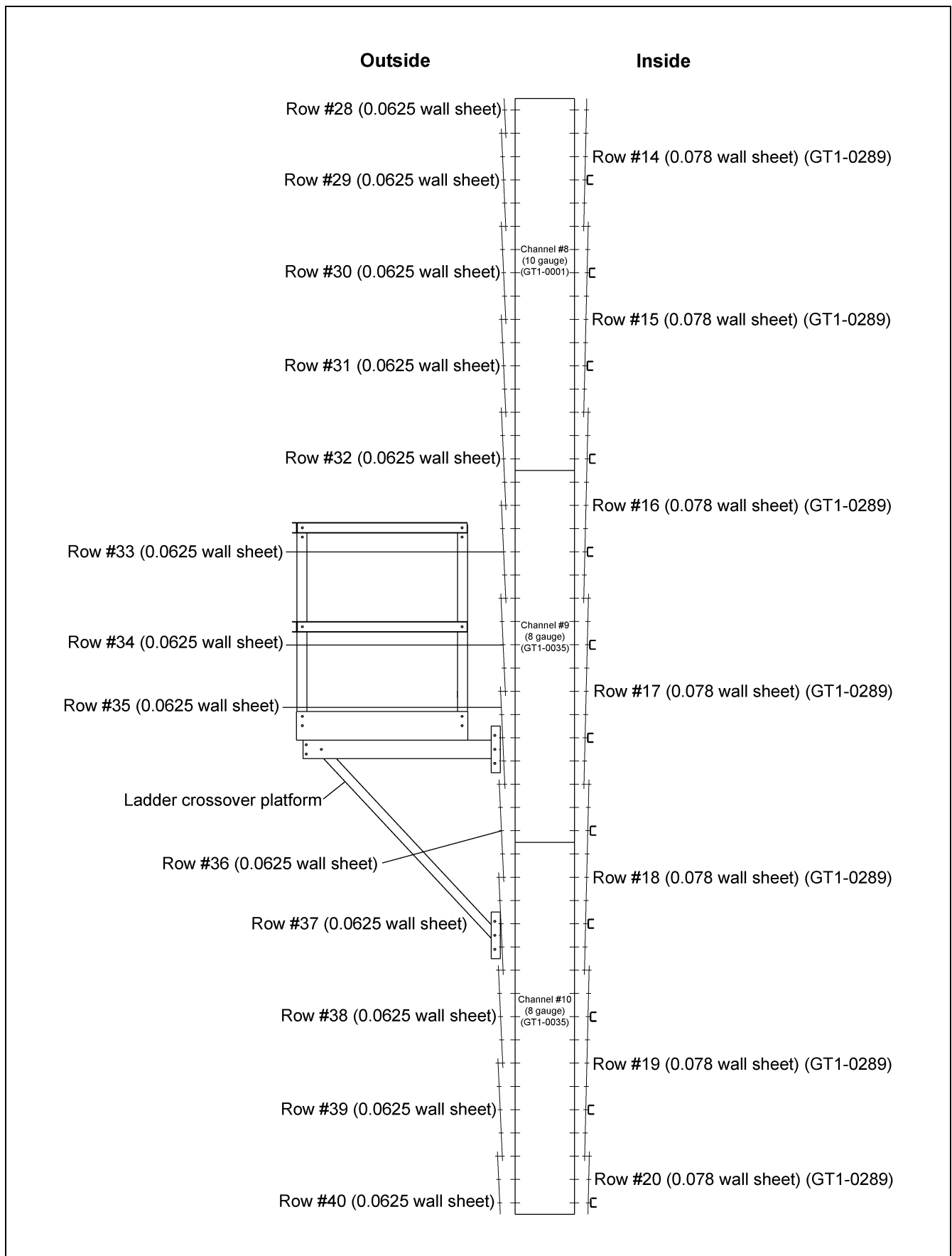

Figure 26DW Clip Placement Z-7060 Channels 8 to 10

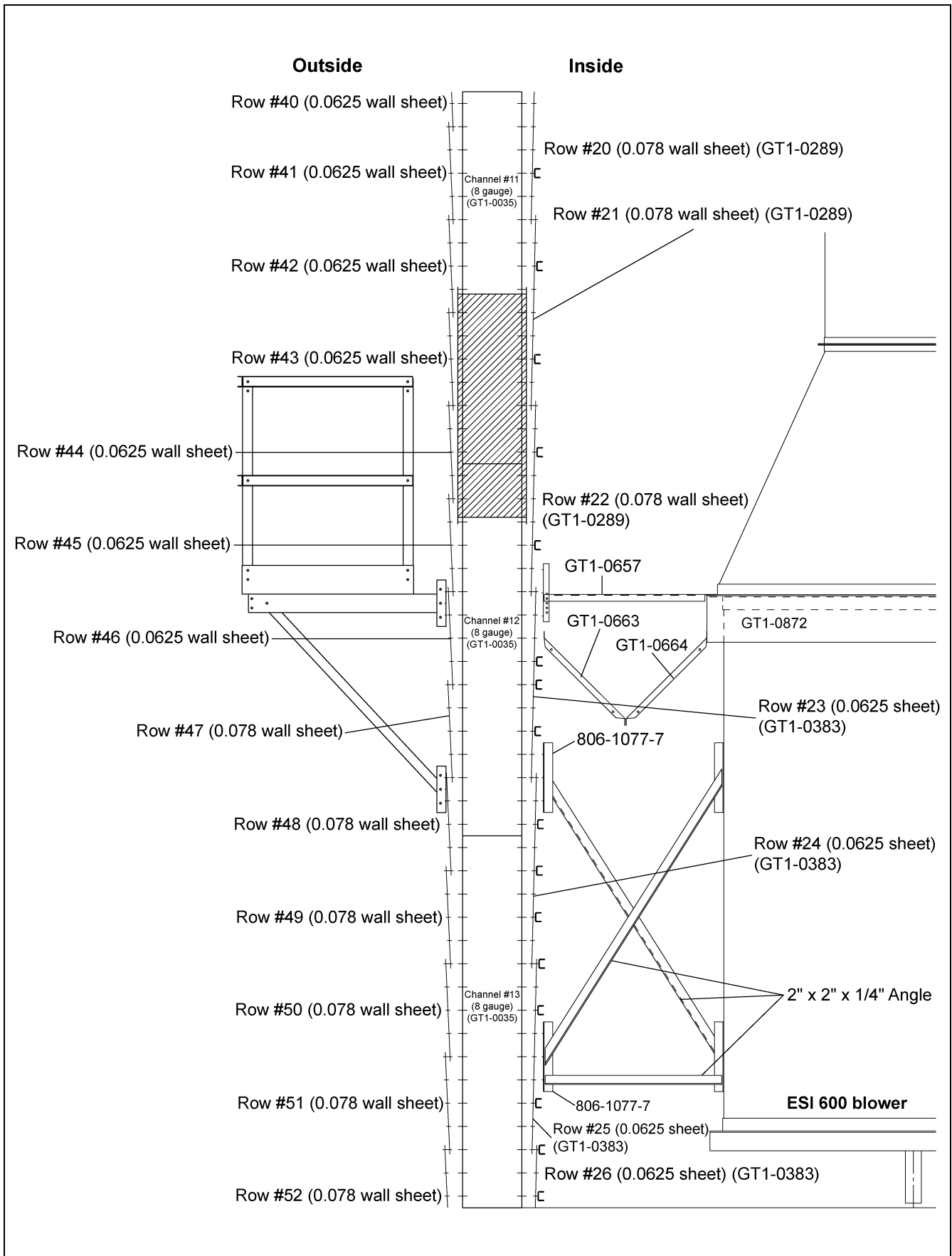

Figure 26DX Clip Placement Z-7060 Channels 11 to 13

26. All Tower Dryer Models Drawings

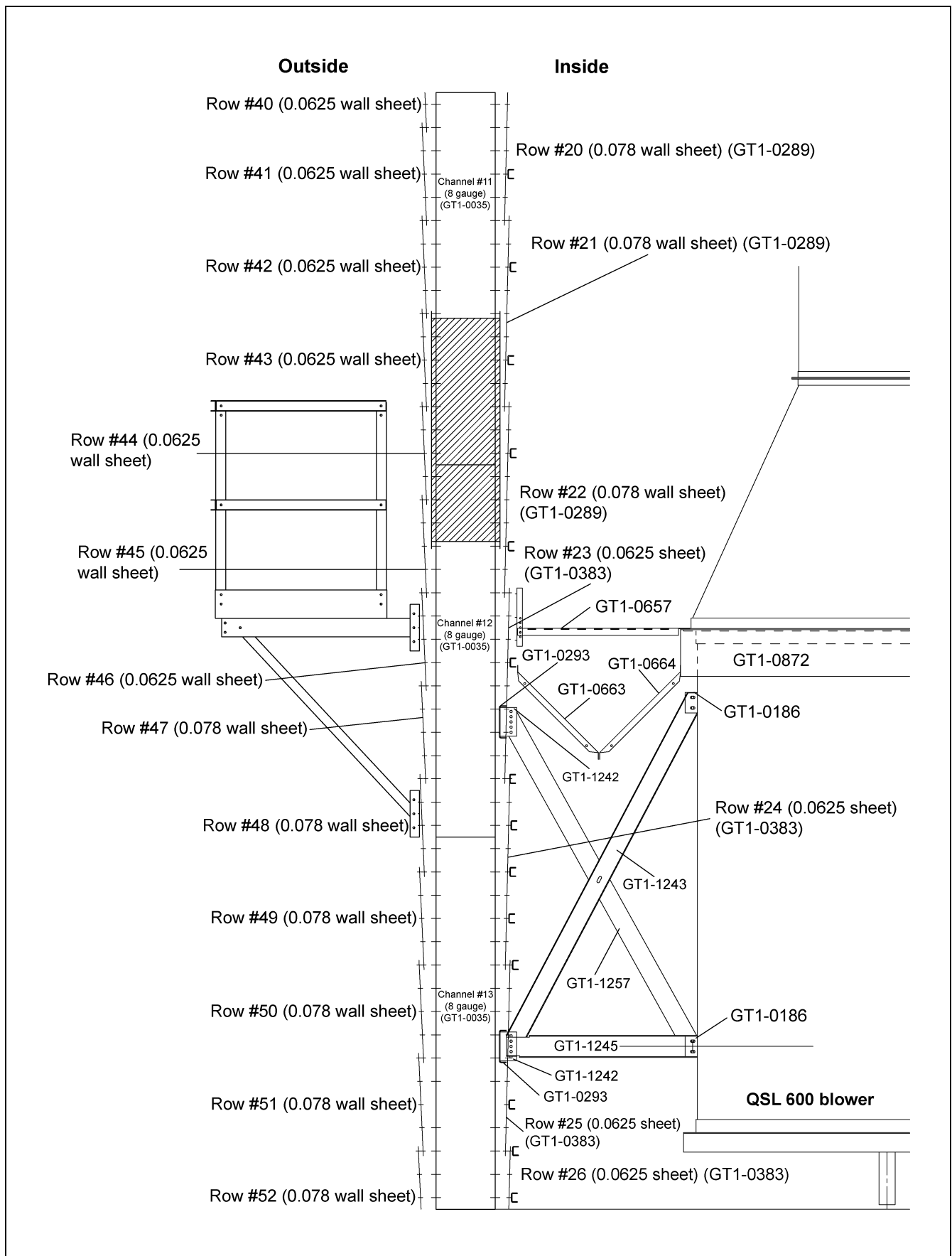

Figure 26DY Clip Placement Z-7060/G-7000 w/ QSL Blowers - Channels 11 to 13

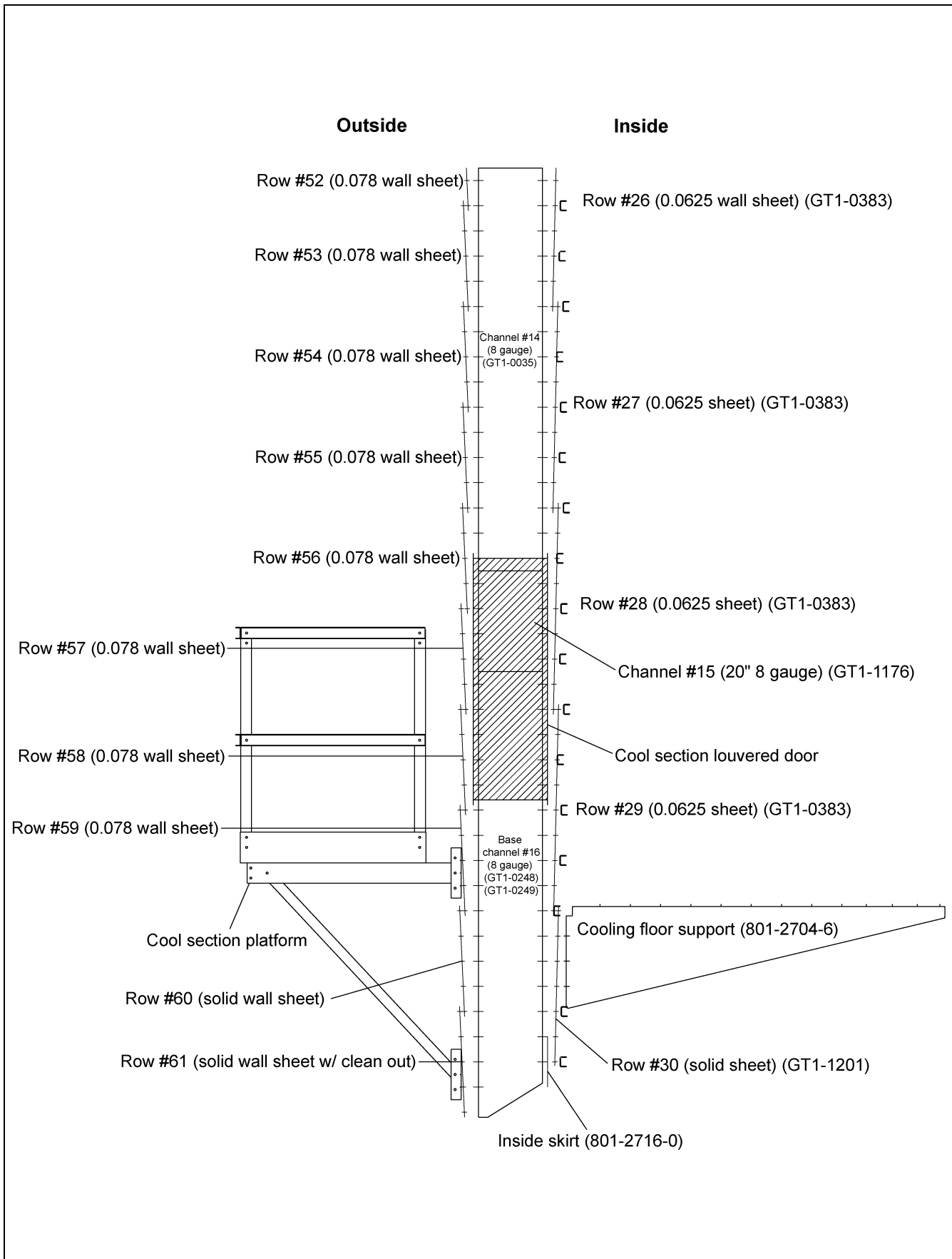

Figure 26DZ Clip Placement Z-7060 Channels 14 to 16

26. All Tower Dryer Models Drawings

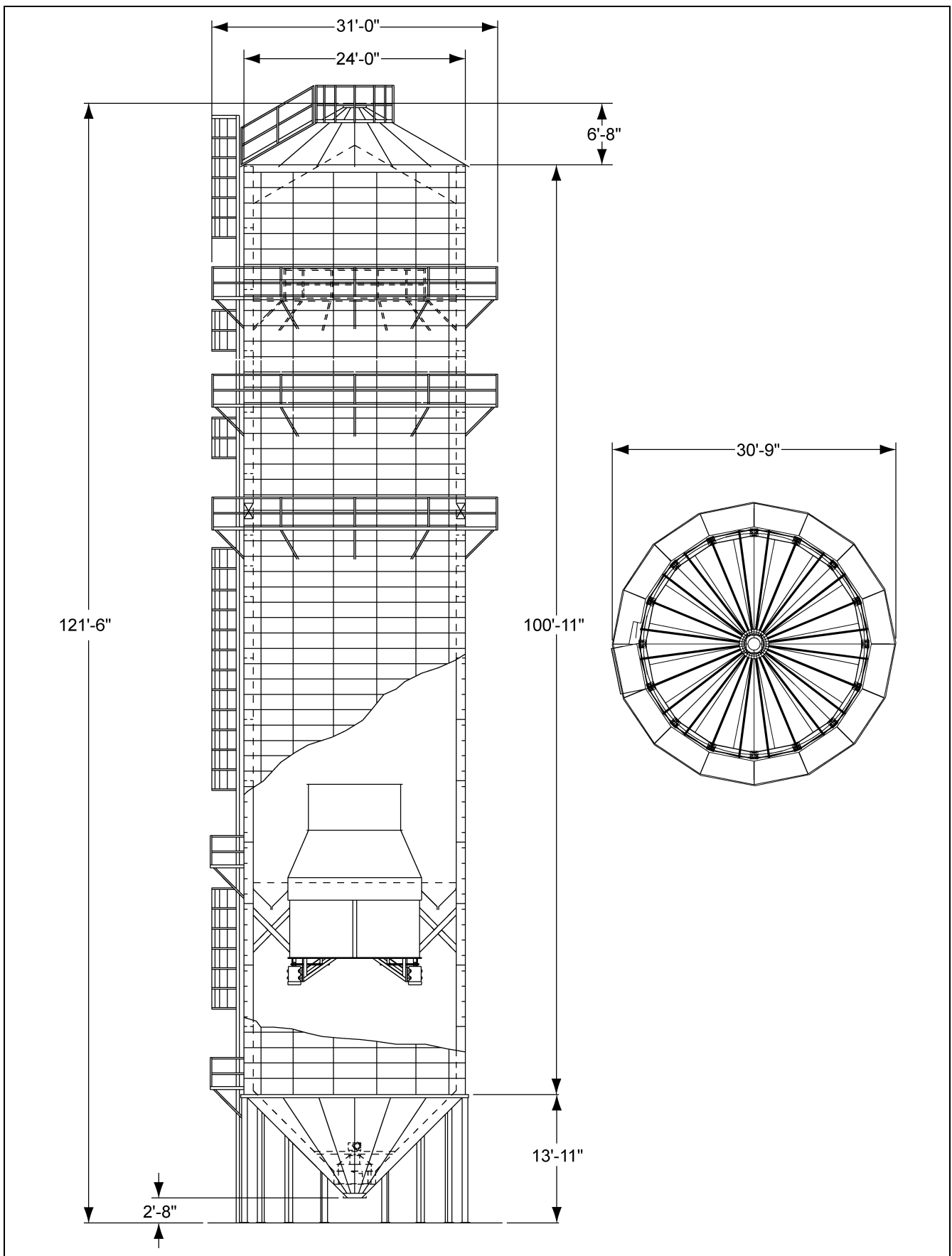

Figure 26EA GSI Tower Dryer Model 7000

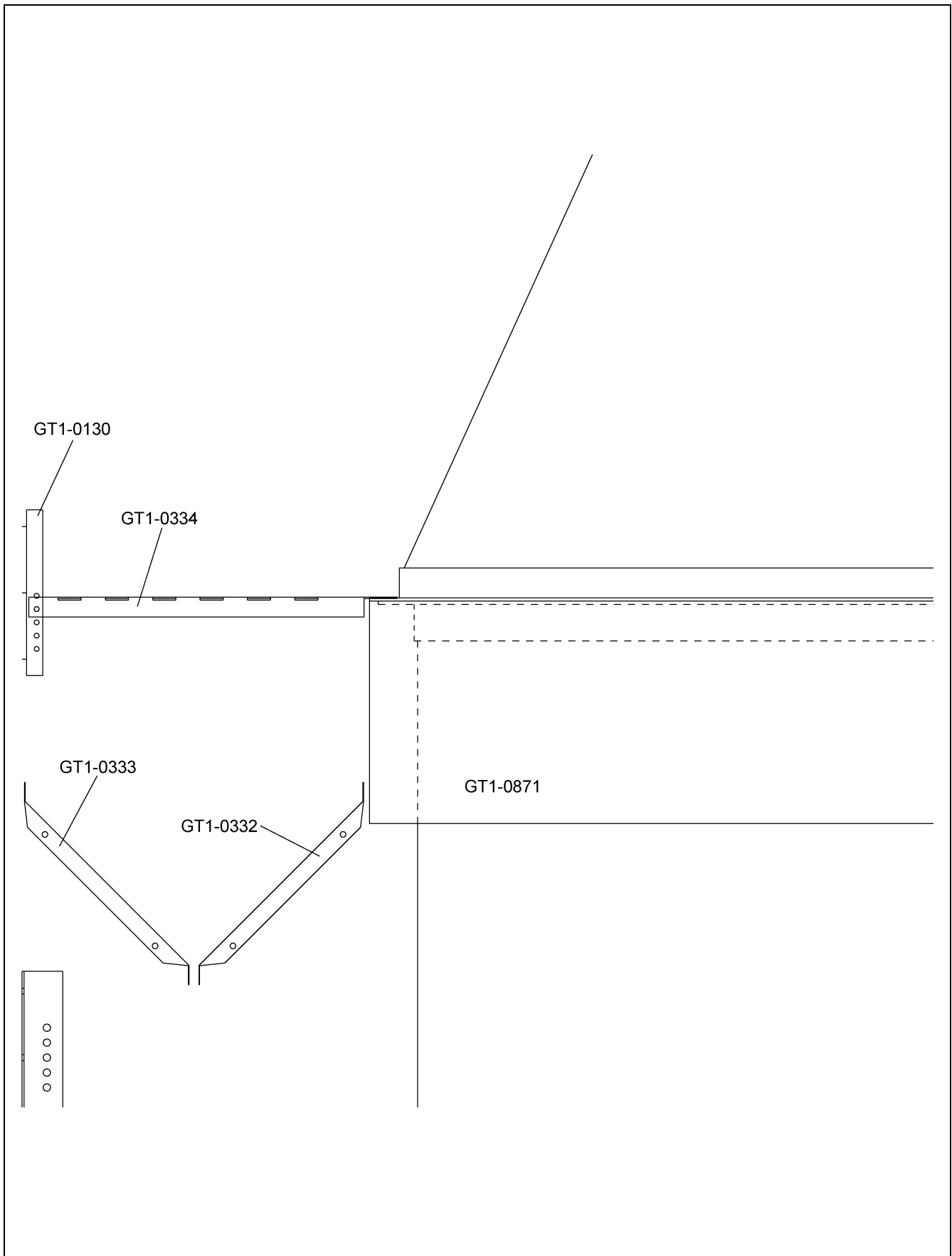

Figure 26EB

26. All Tower Dryer Models Drawings

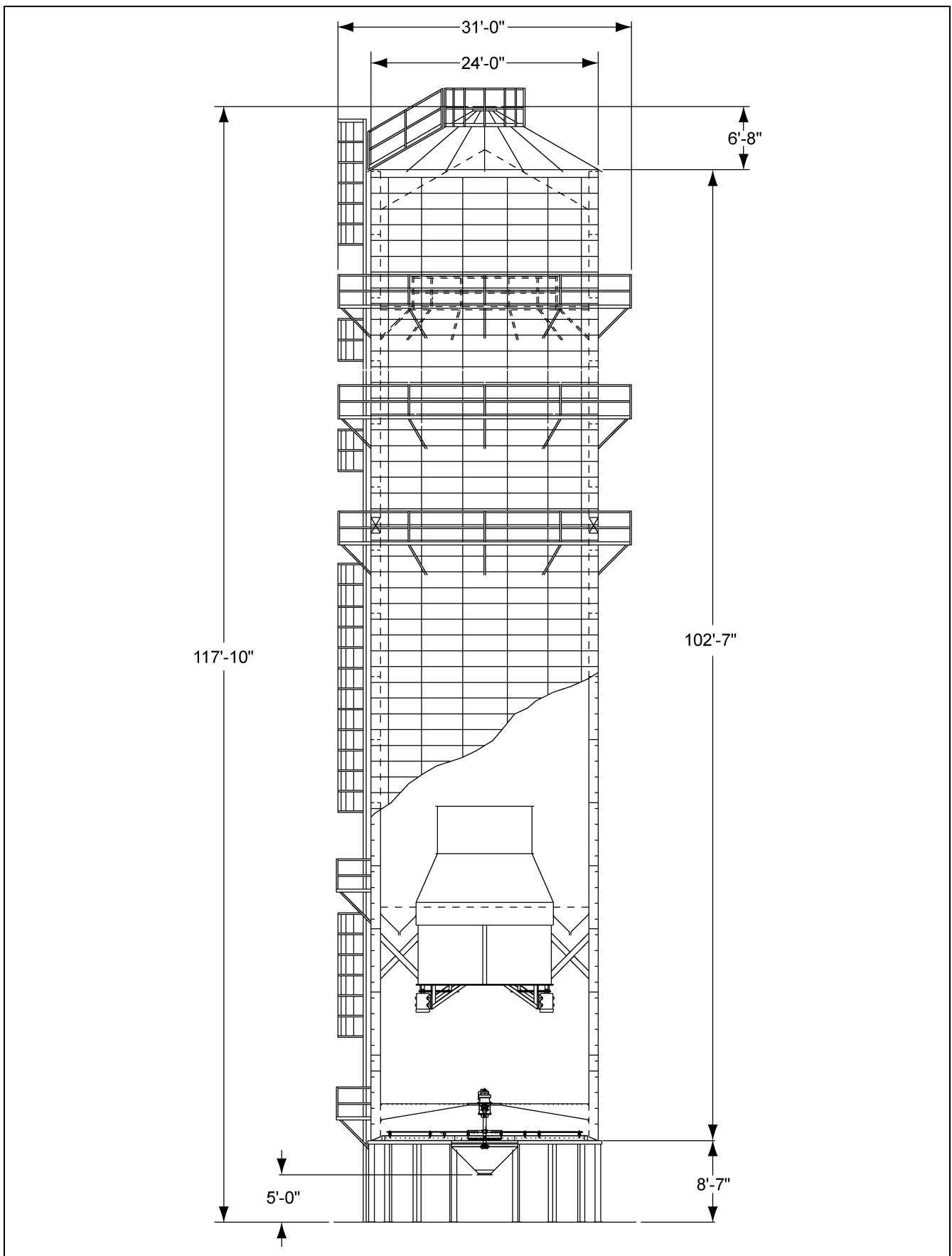

Figure 26EC Zimmerman Tower Dryer Model Z-7060

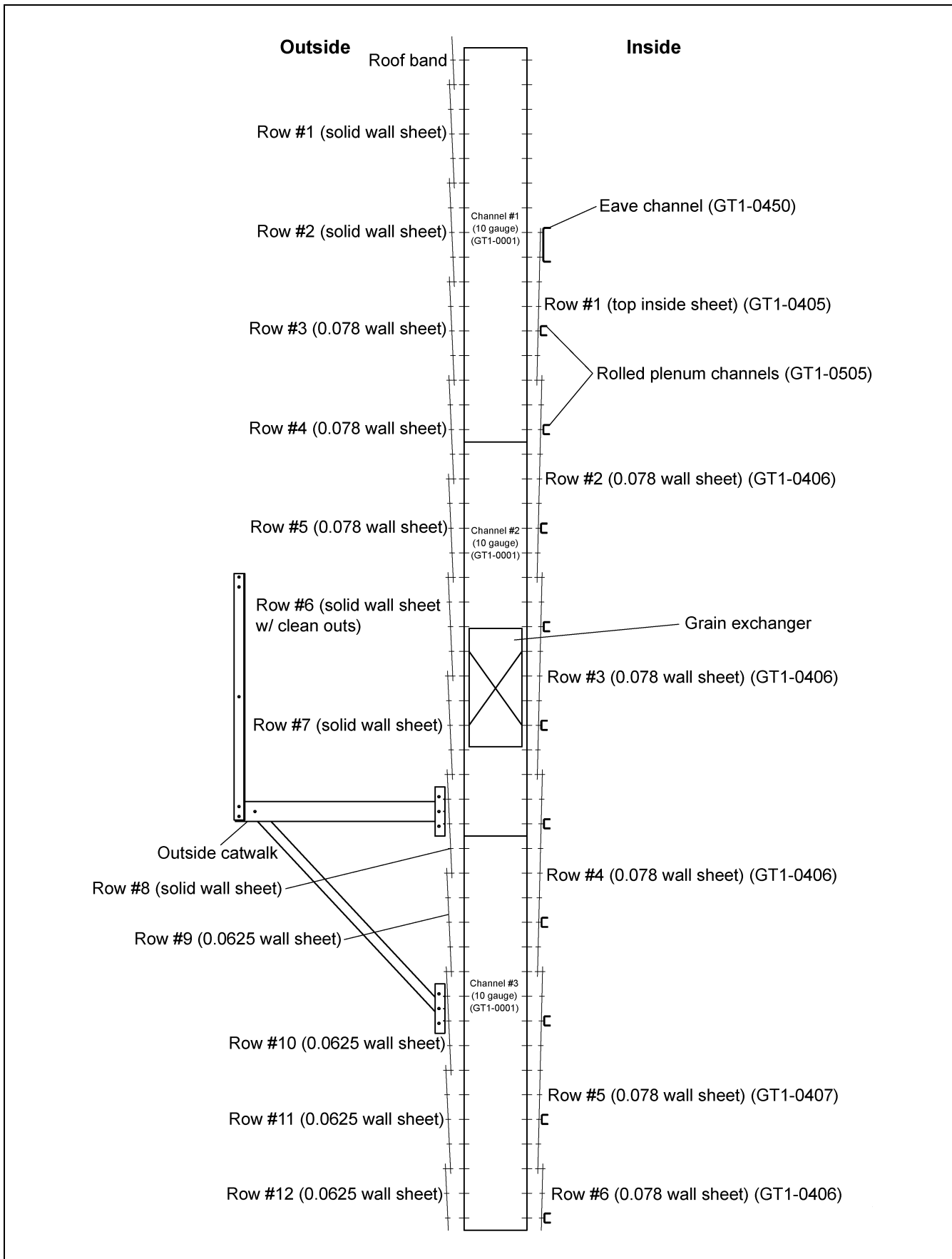

Figure 26ED Clip Placement Z-1200 Channels 1 to 3

26. All Tower Dryer Models Drawings

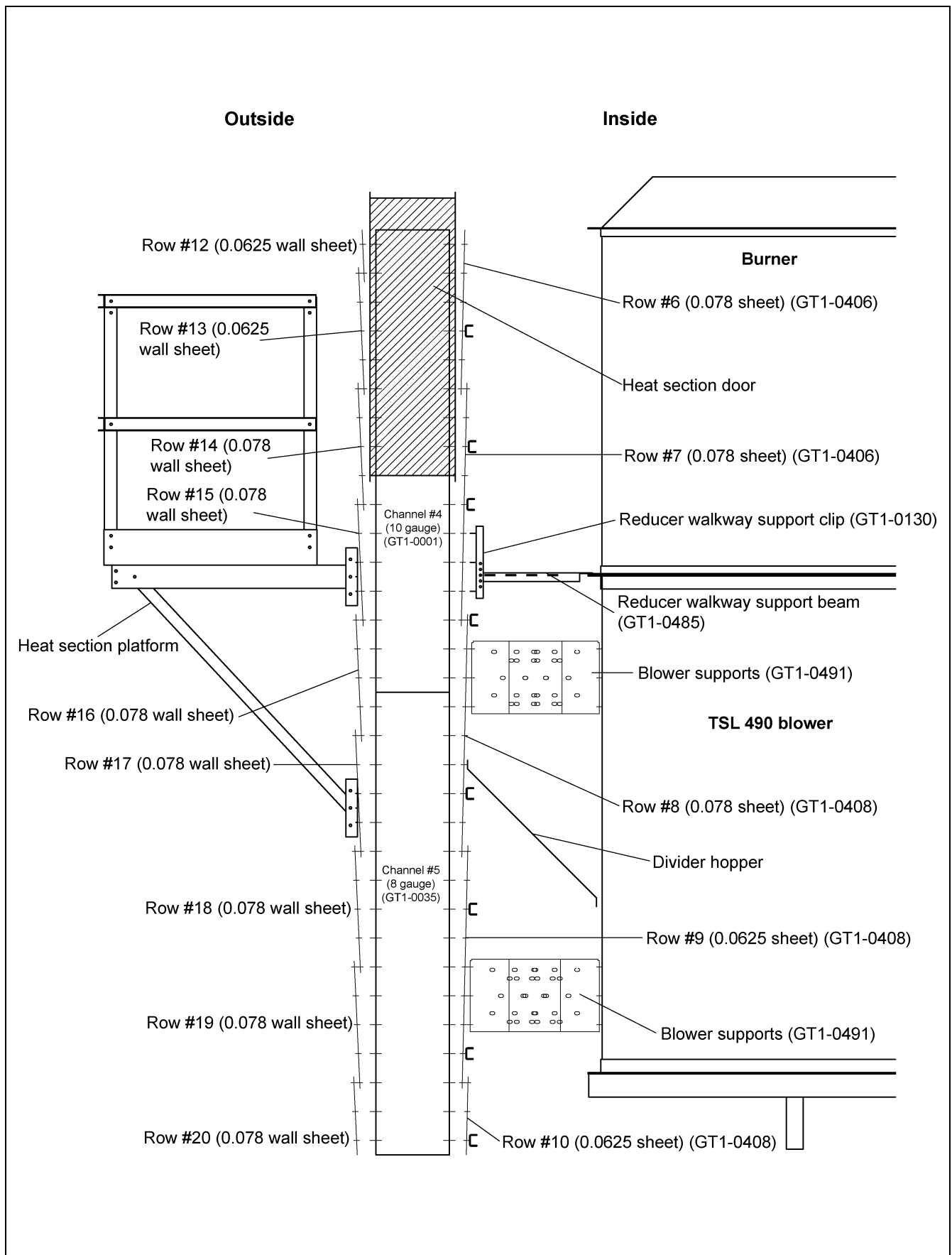

Figure 26EE Clip Placement G-1200 Channels 4 to 5

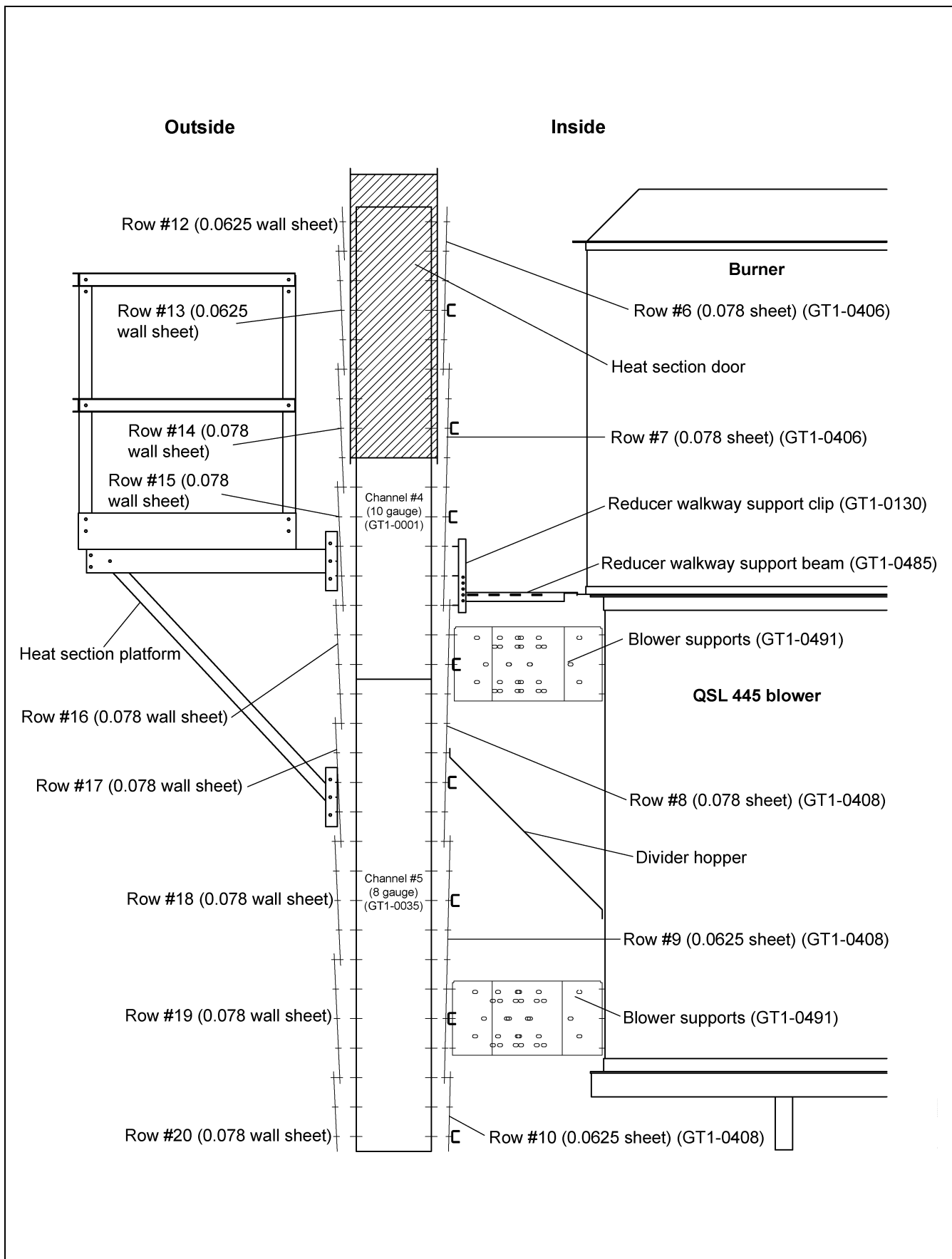

Figure 26EF Clip Placement G-1200 Channels 4 to 5

26. All Tower Dryer Models Drawings

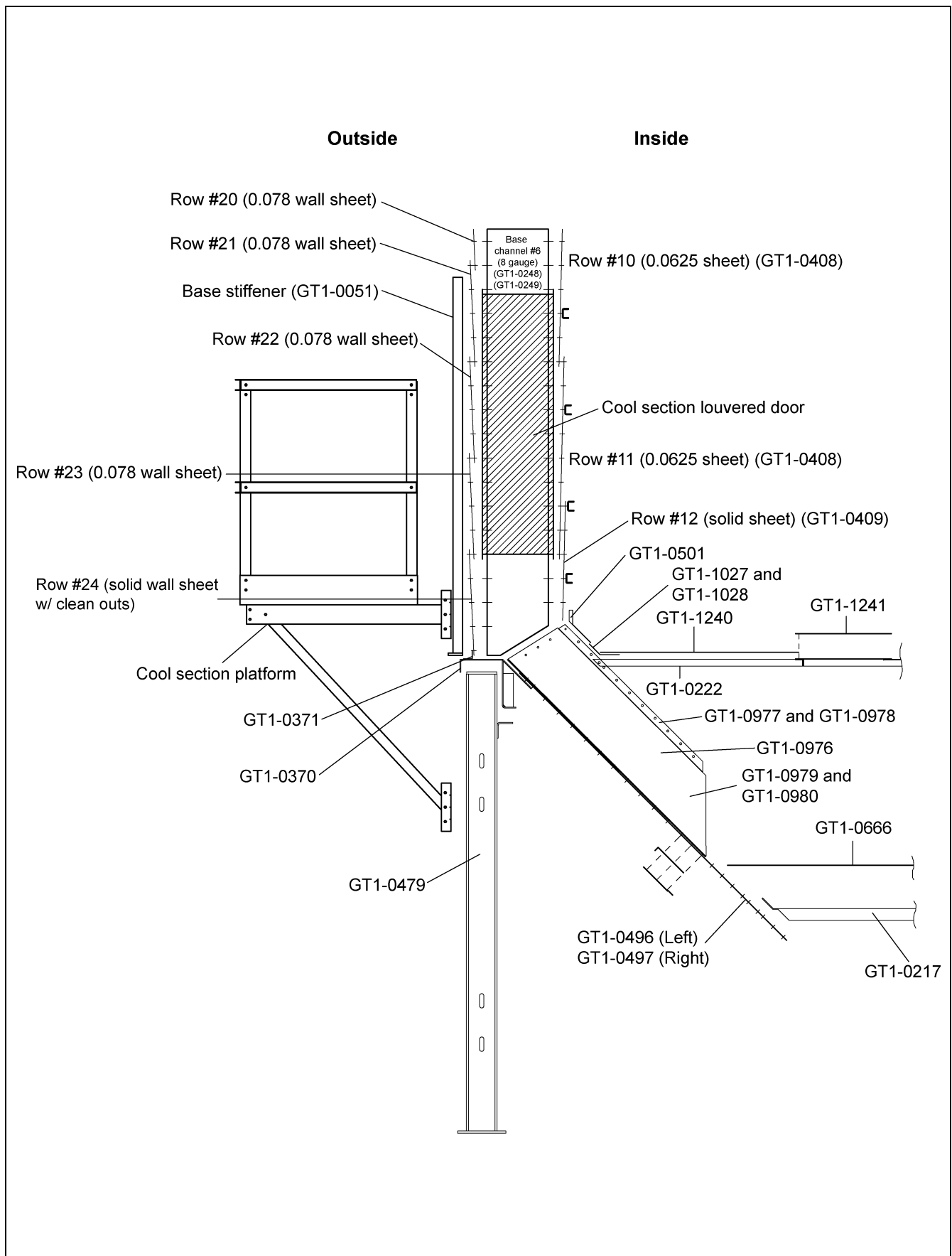

Figure 26EG Clip Placement G-1200 Channel 6

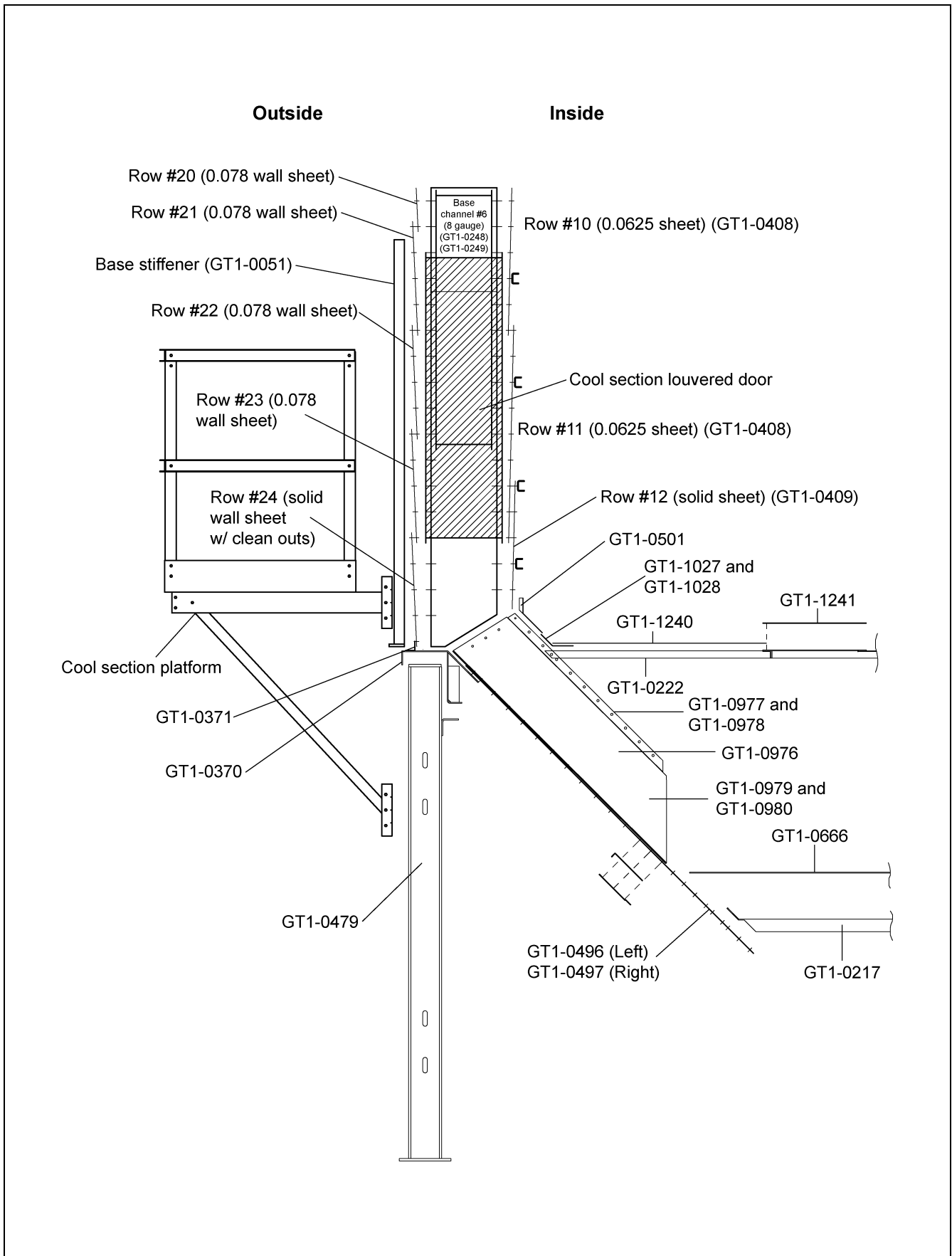

Figure 26EH Clip Placement G-1200 Channel 6

26. All Tower Dryer Models Drawings

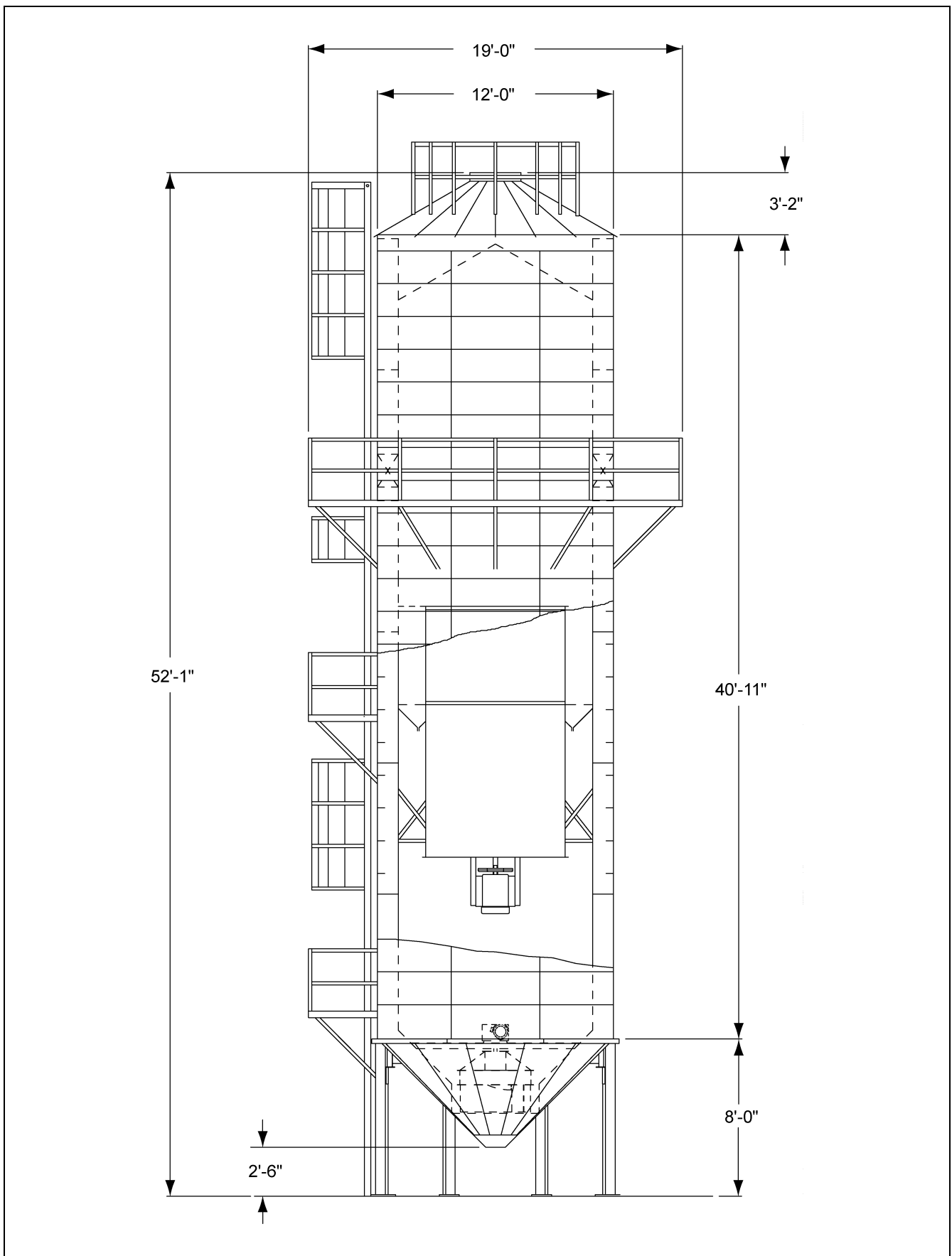

Figure 26EI GSI Tower Dryer Model 1200

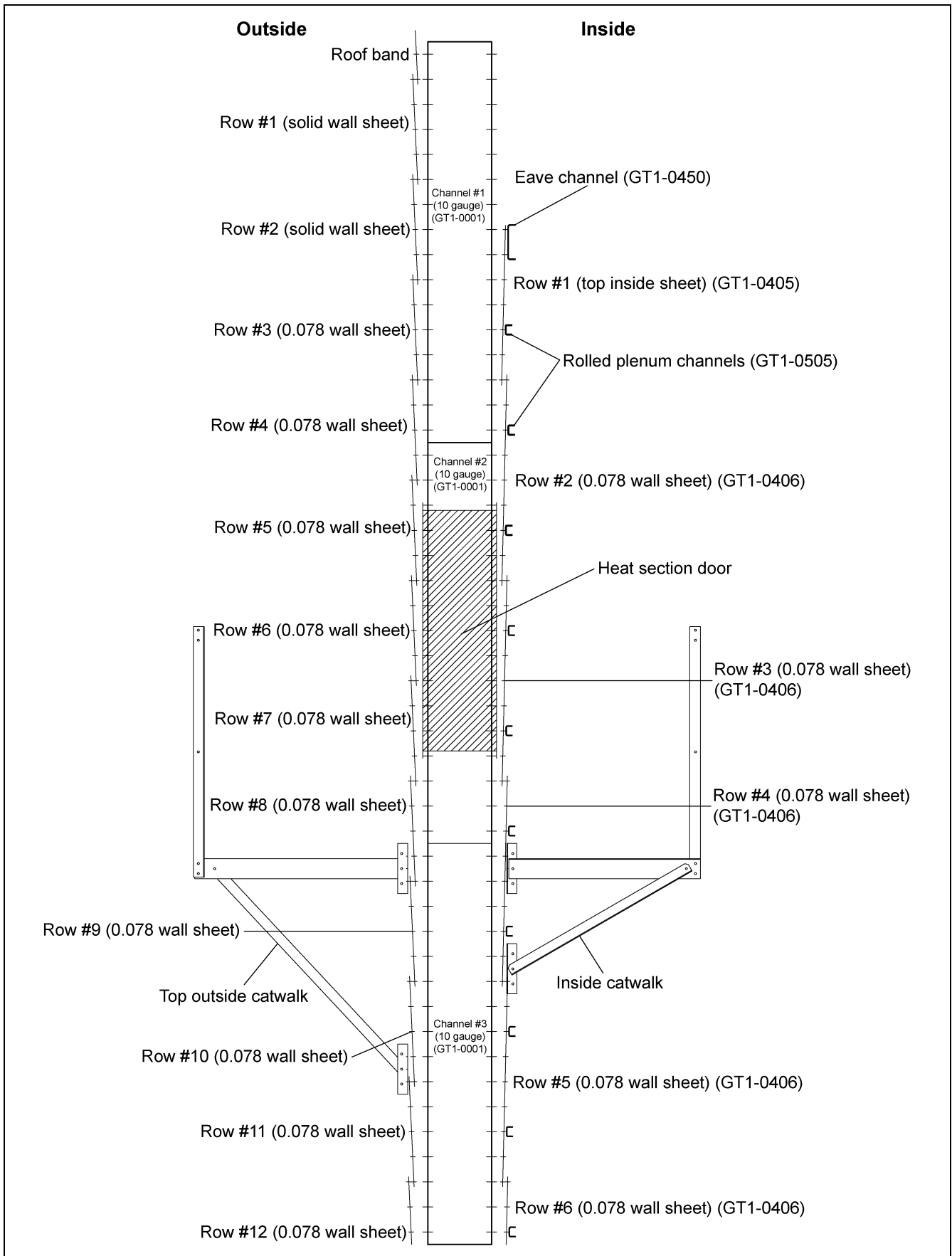

Figure 26EJ Clip Placement G-2000 Channels 1 to 3

26. All Tower Dryer Models Drawings

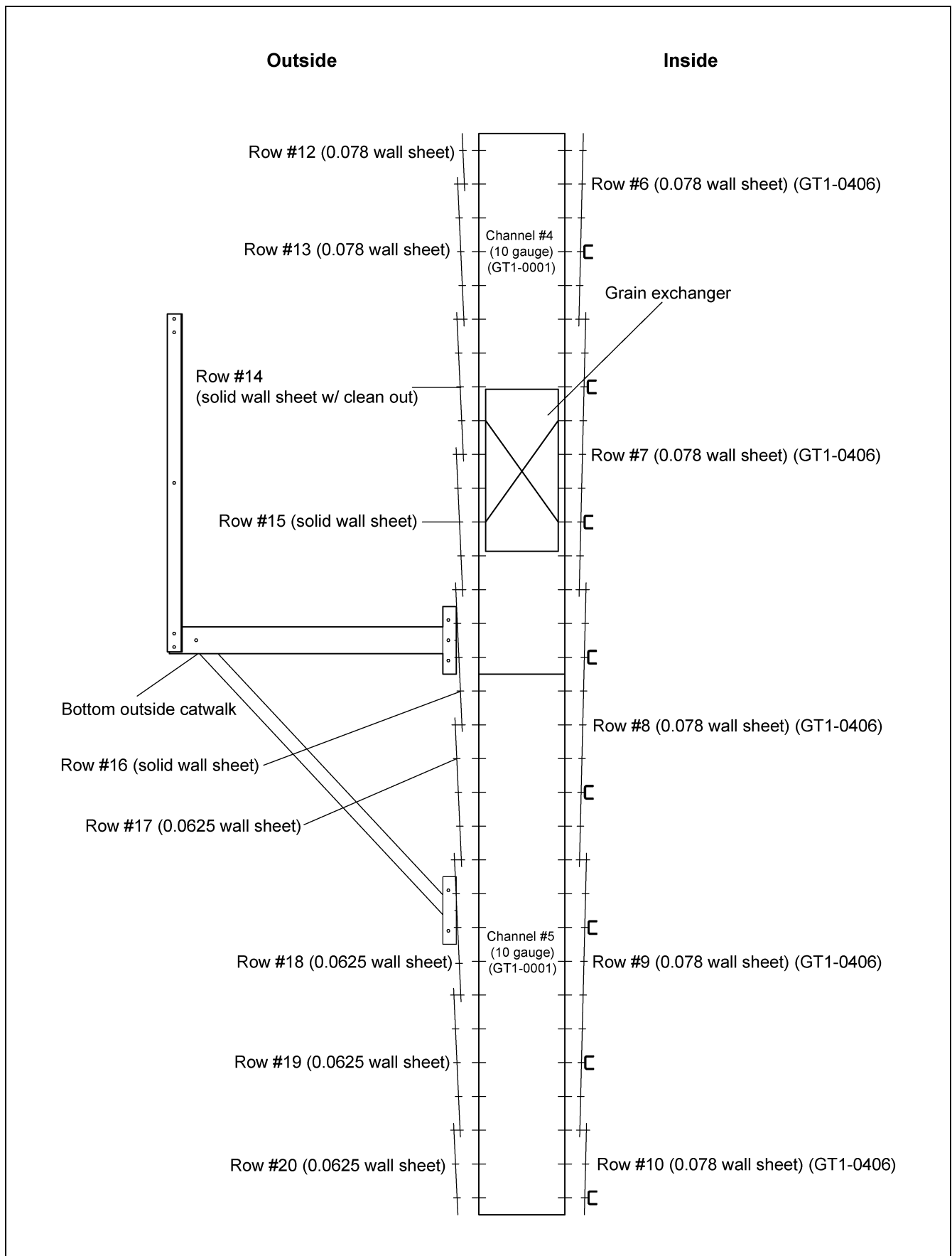

Figure 26EK Clip Placement G-2000 Channels 4 to 5

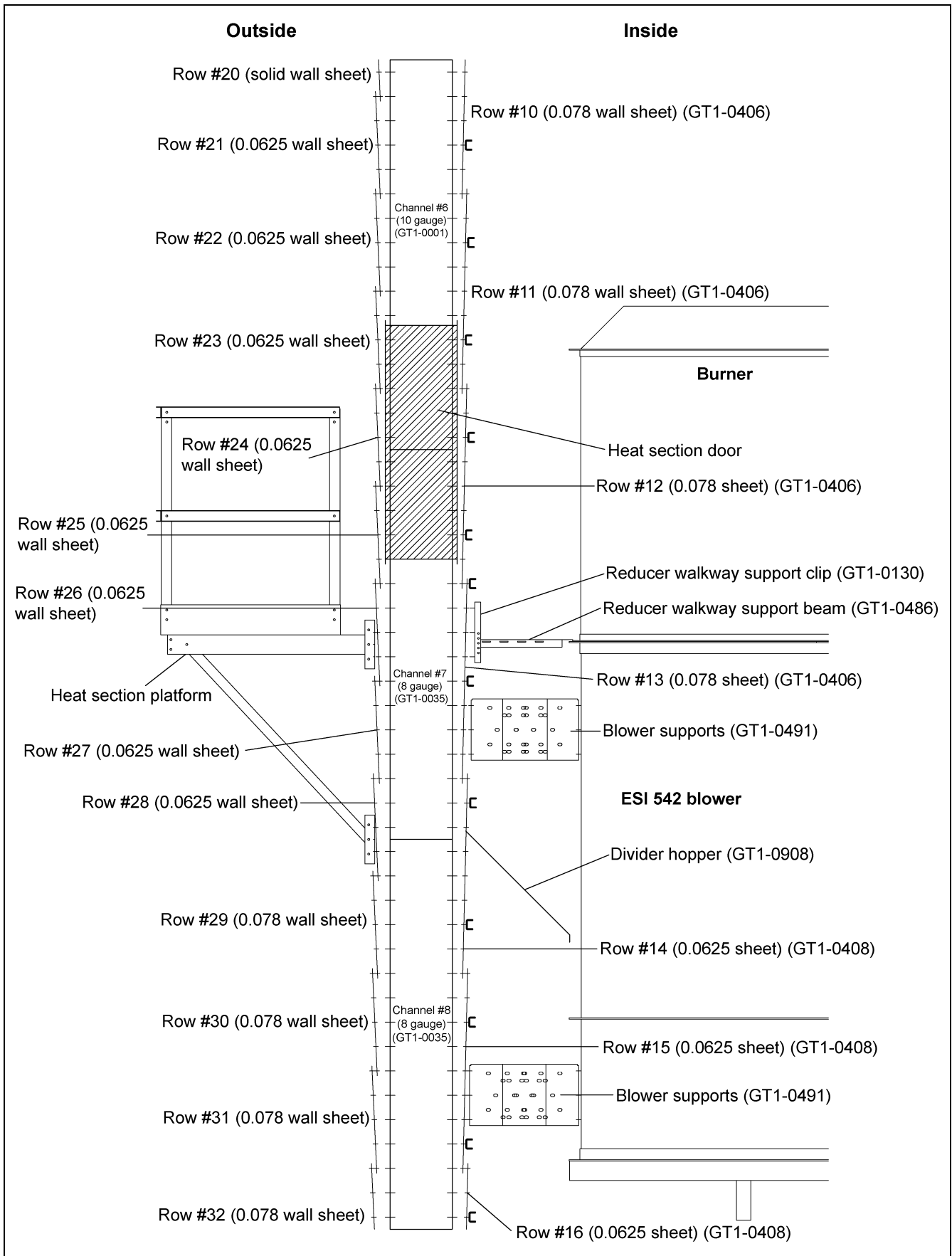

Figure 26EL Clip Placement G-2000 Channels 6 to 8

26. All Tower Dryer Models Drawings

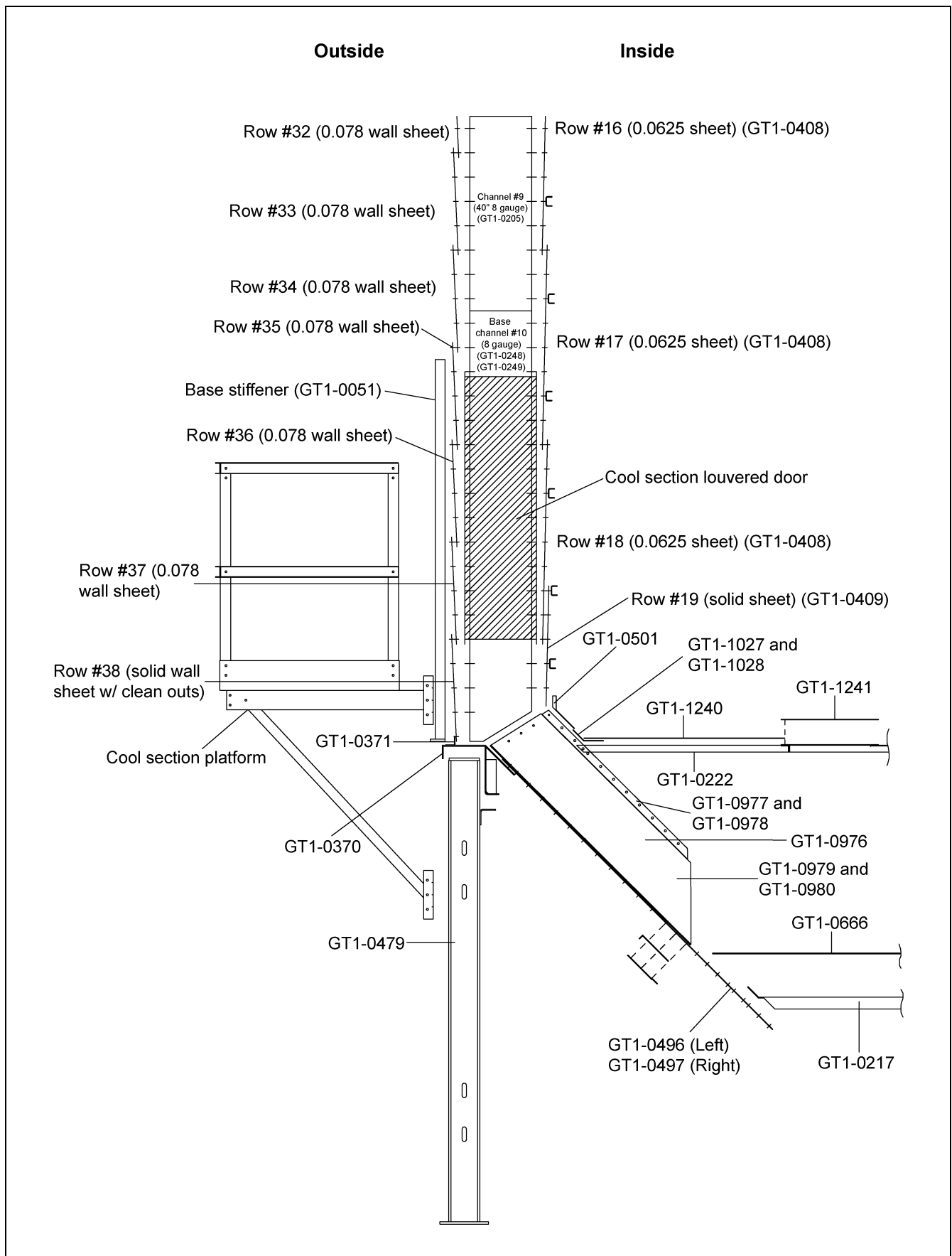

Figure 26EM Clip Placement G-2000 Channels 9 to 10

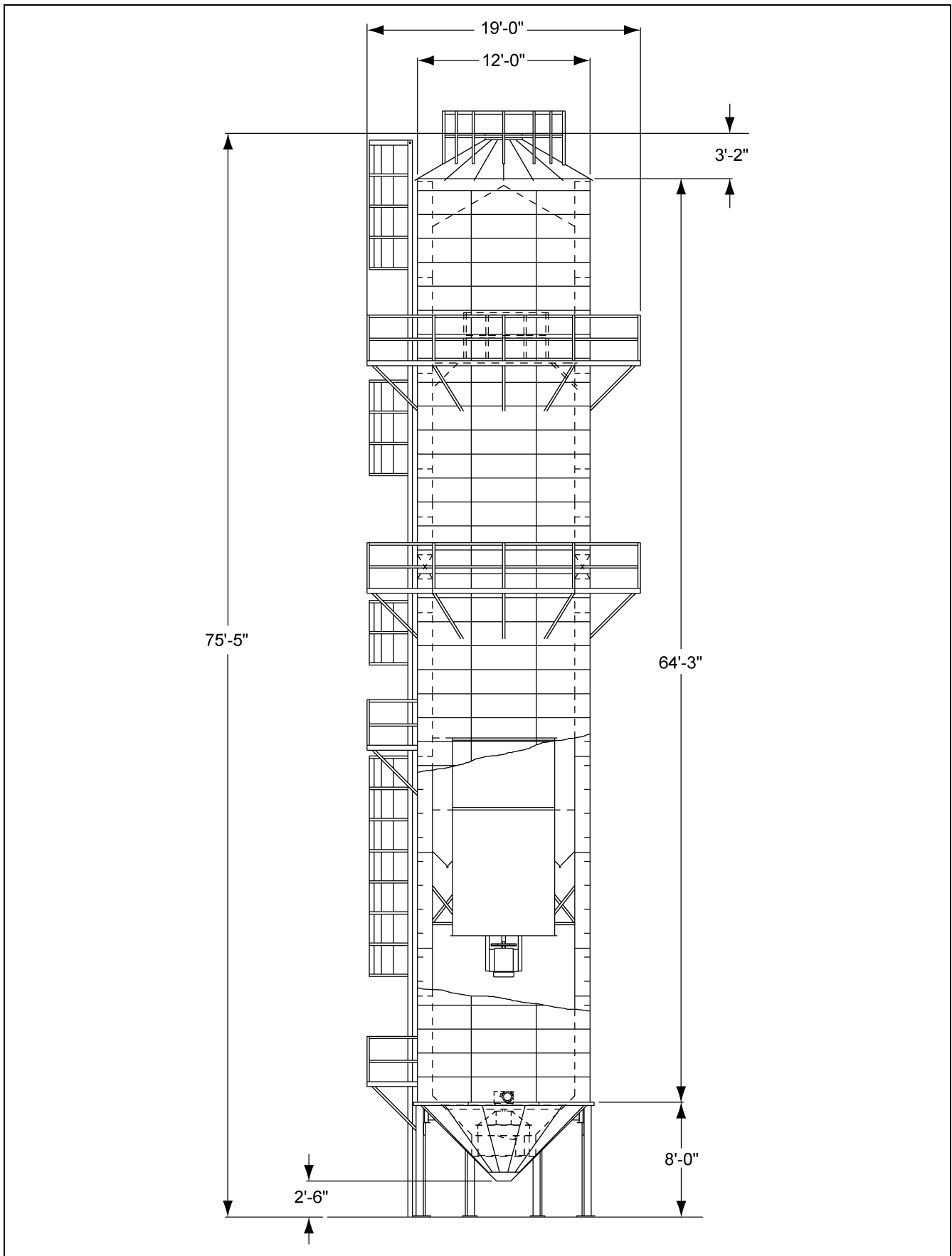

Figure 26EN GSI Tower Dryer Model 2000

26. All Tower Dryer Models Drawings

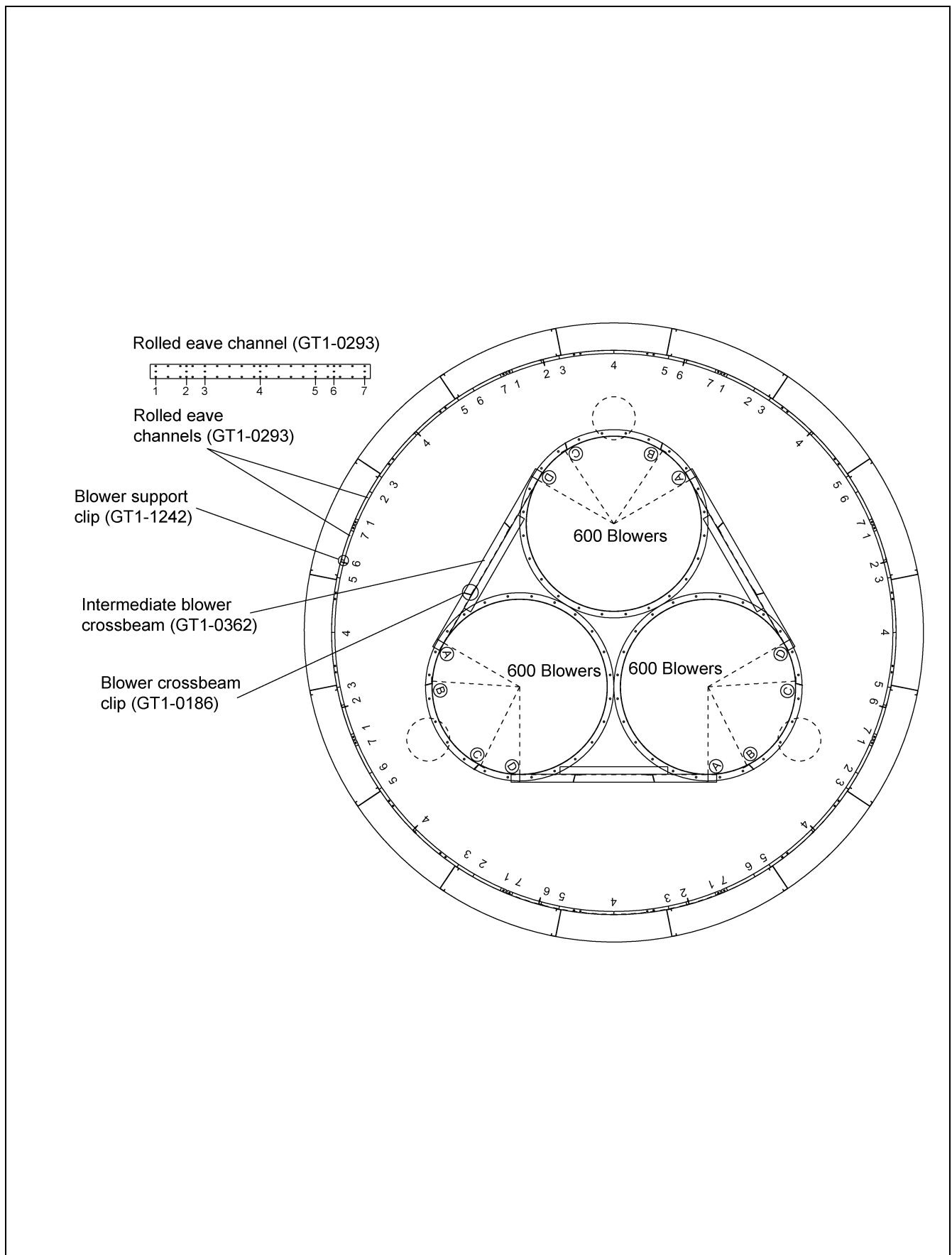

Figure 26EO 600 Blower Attachment Clip Location - 24' Dryers

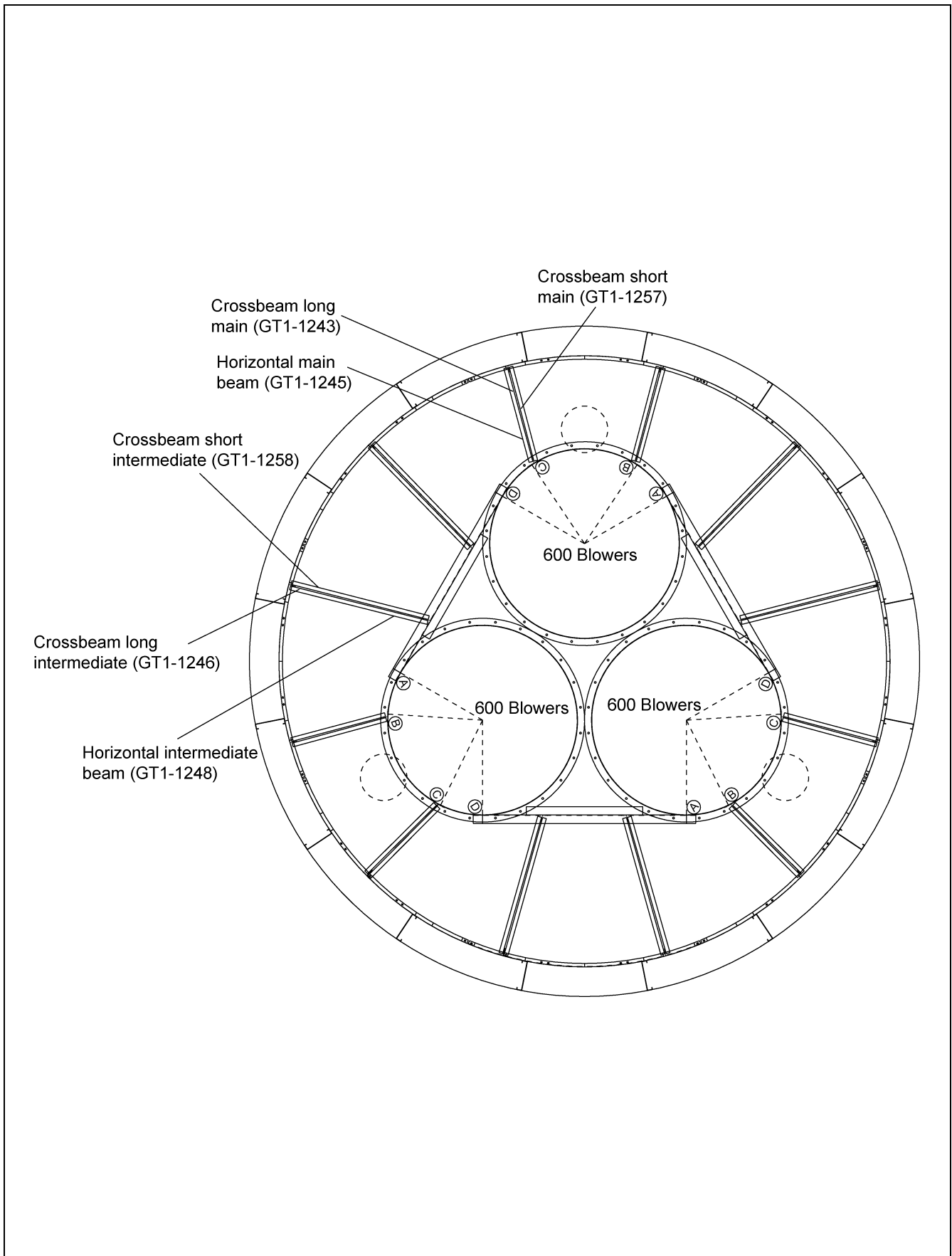

Figure 26EP 600 Blower Attachment X-Bracing - 24' Dryers

26. All Tower Dryer Models Drawings

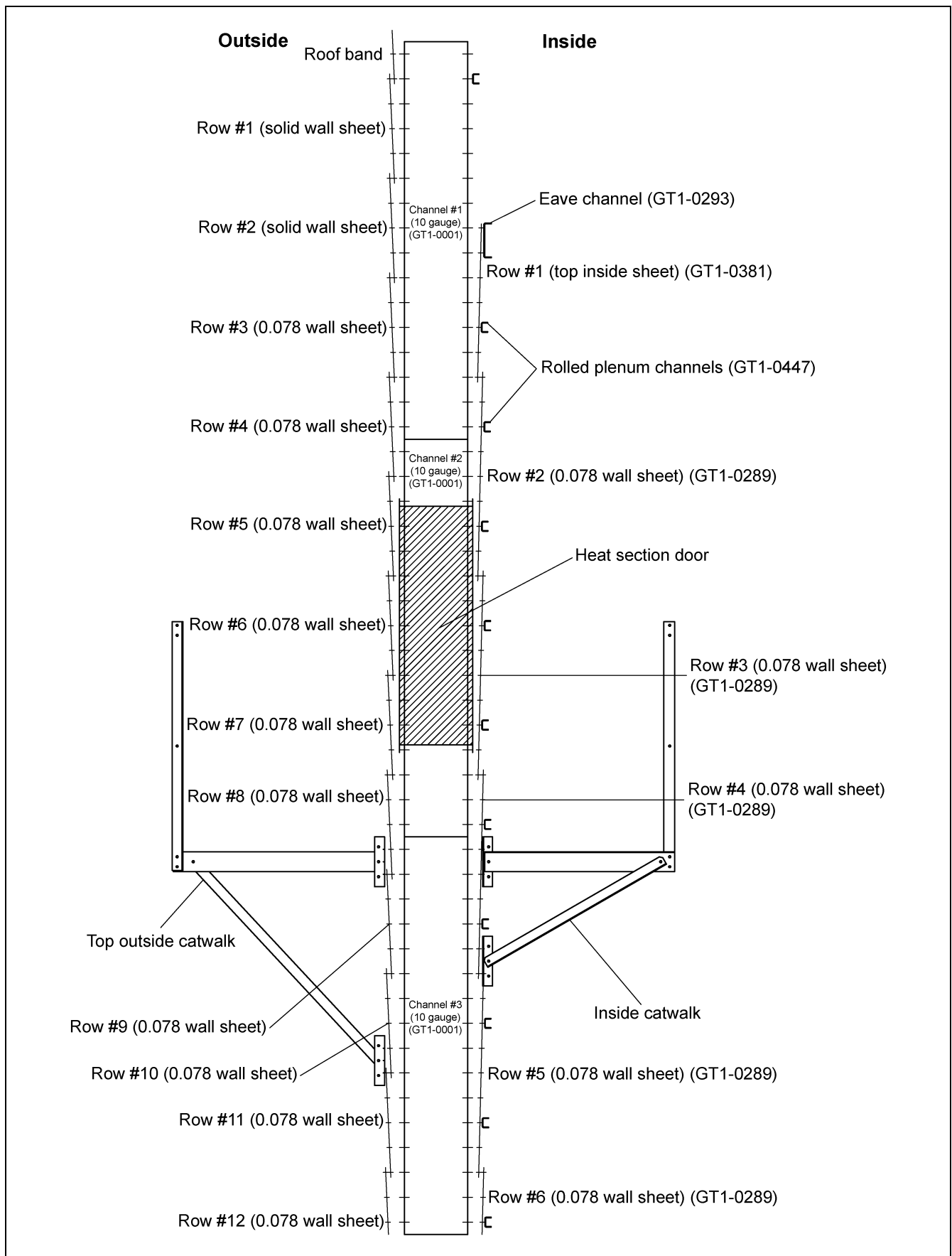

Figure 26EQ Clip Placement Z-6055 Channels 1 to 3

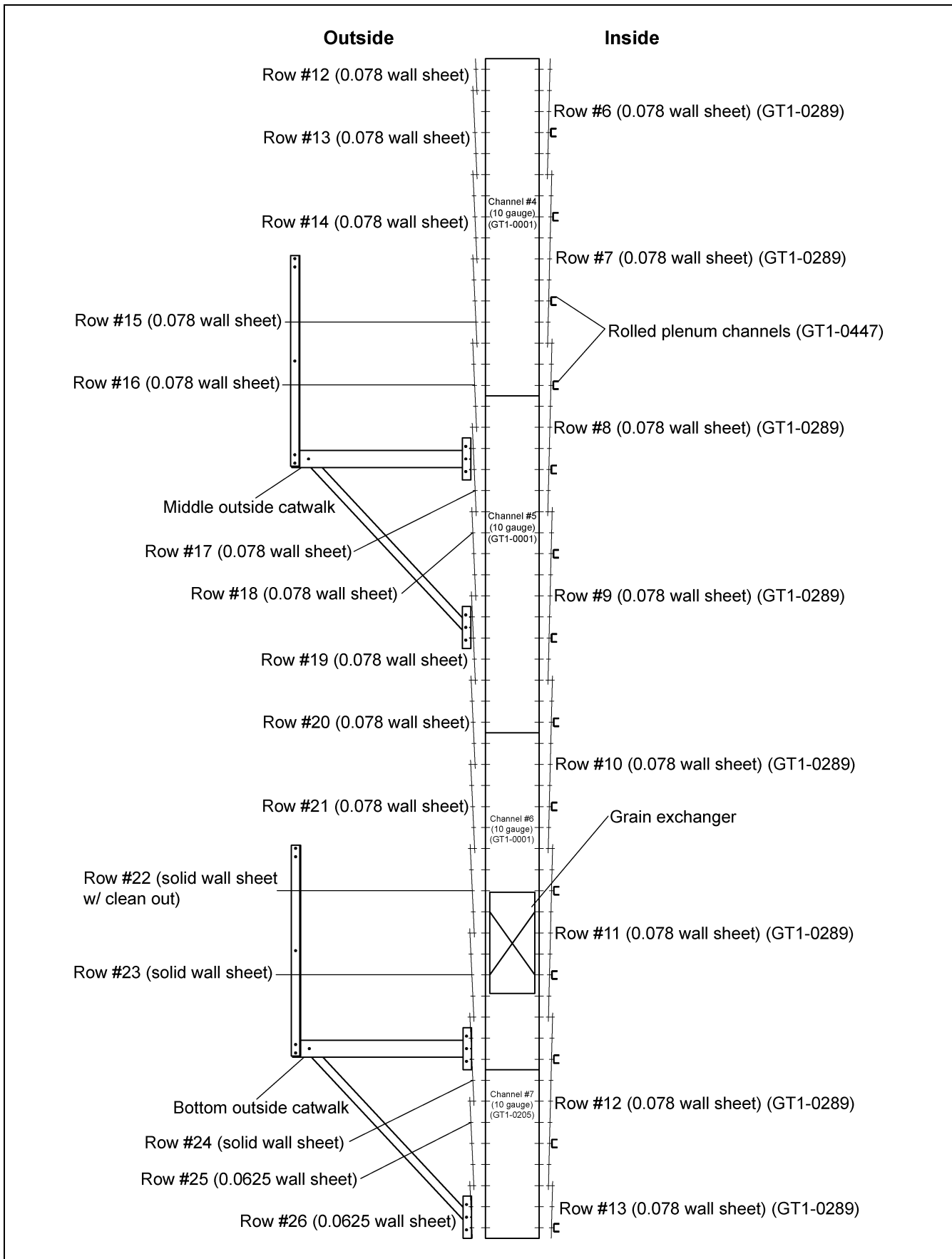

Figure 26ER Clip Placement Z-6055 Channels 4 to 7

26. All Tower Dryer Models Drawings

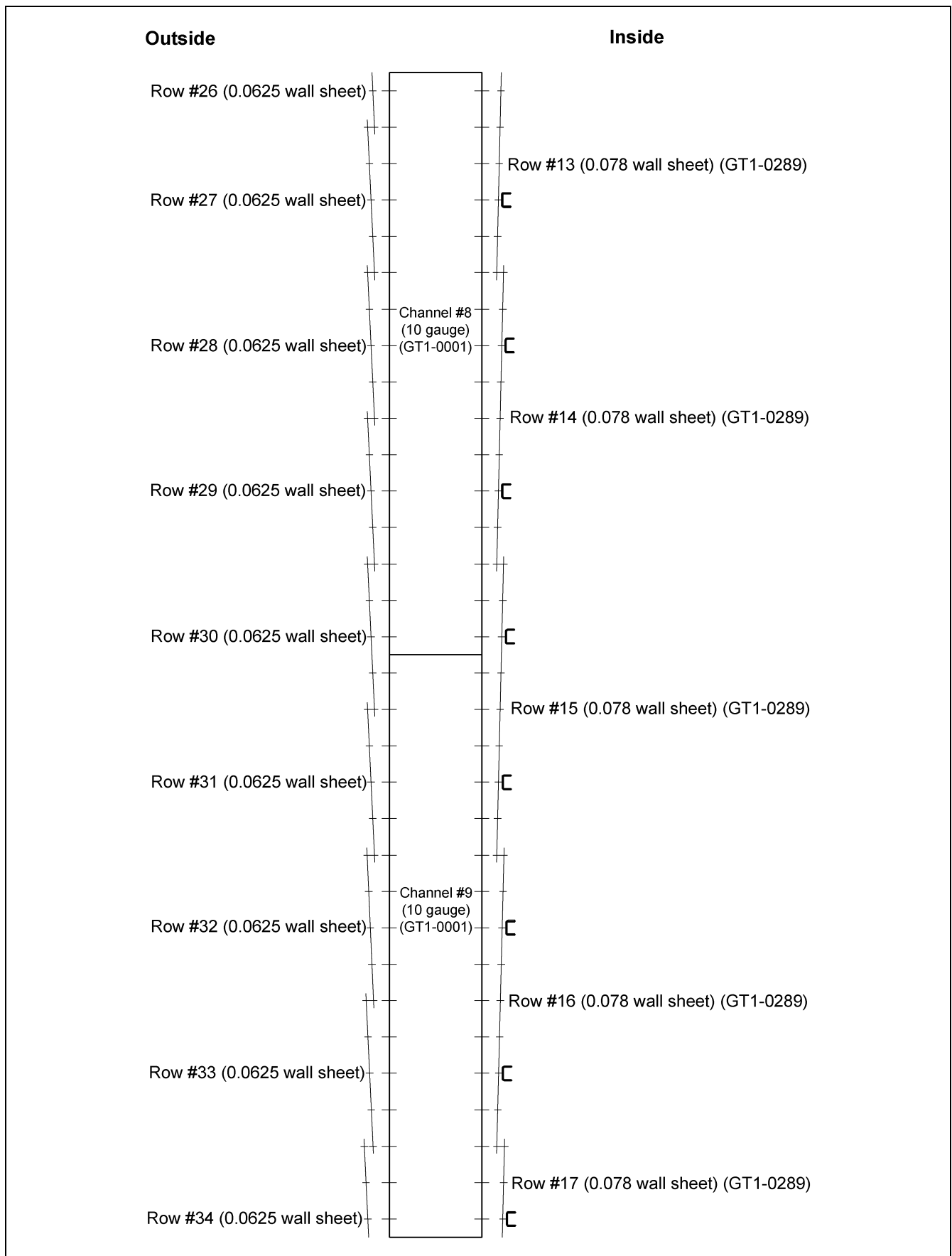

Figure 26ES Clip Placement Z-6055 Channels 8 to 9

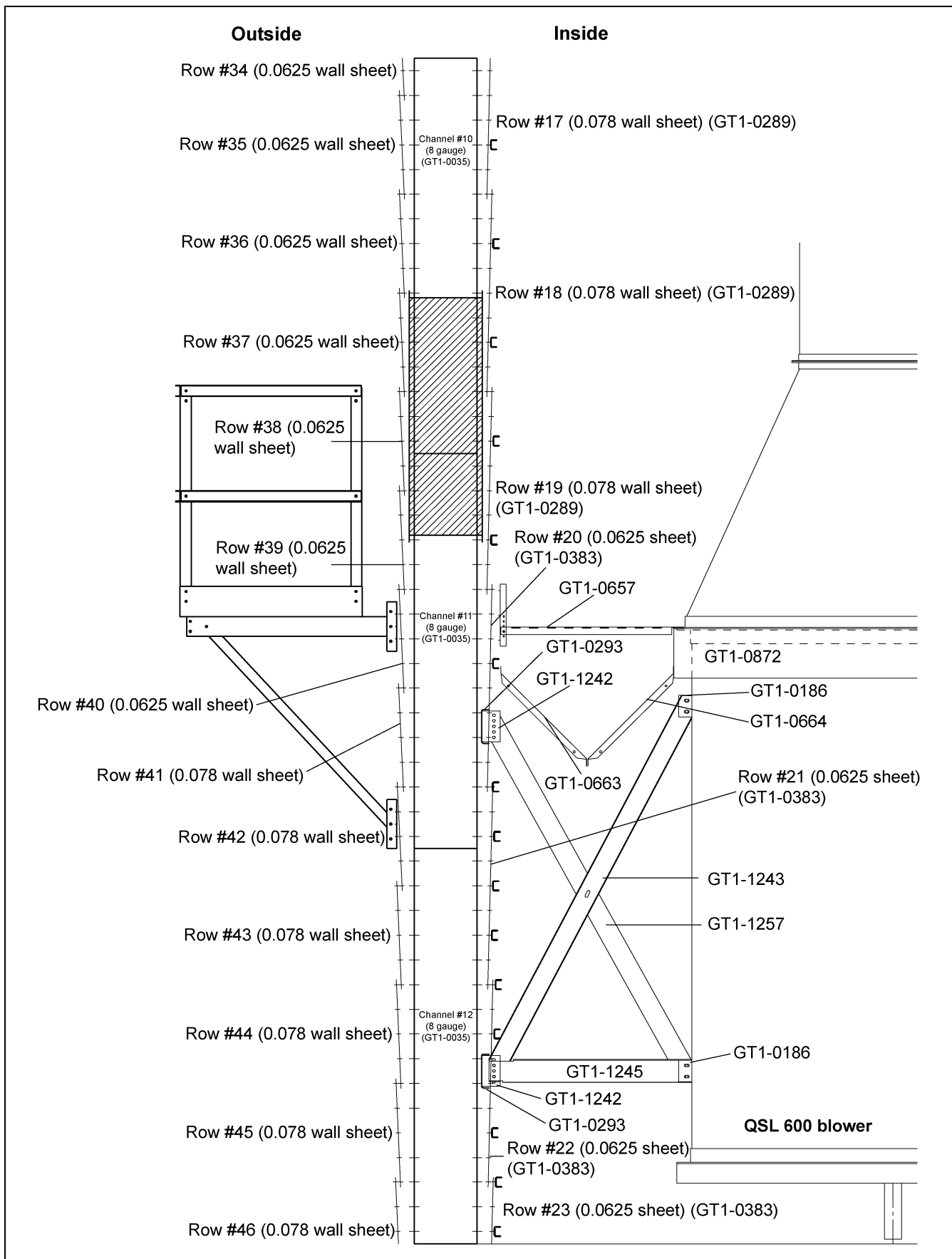

Figure 26ET Clip Placement Z-6055 w/ QSL Blowers Channels 10 to 12

26. All Tower Dryer Models Drawings

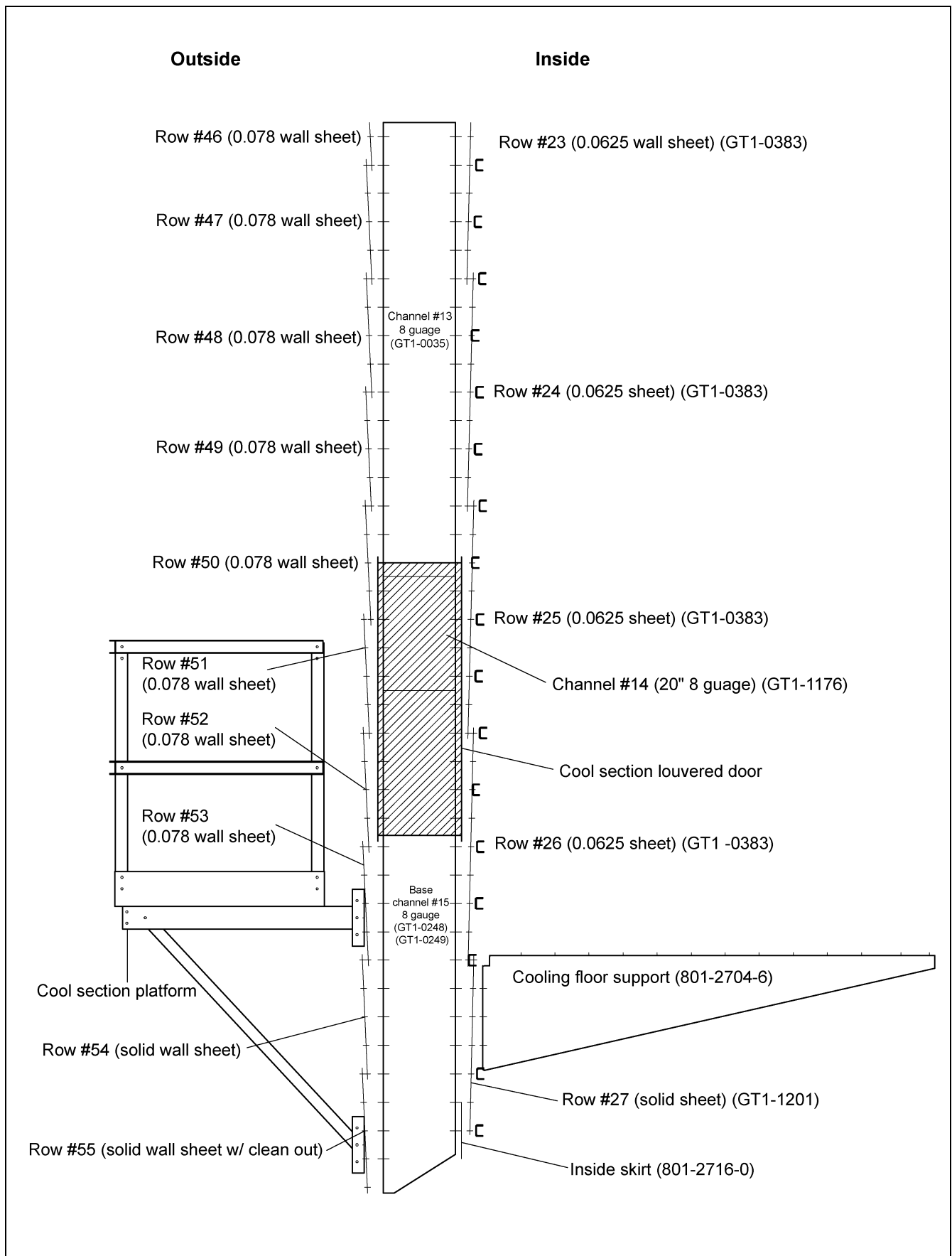

Figure 26EU Clip Placement Z-6055 Channels 13 to 15

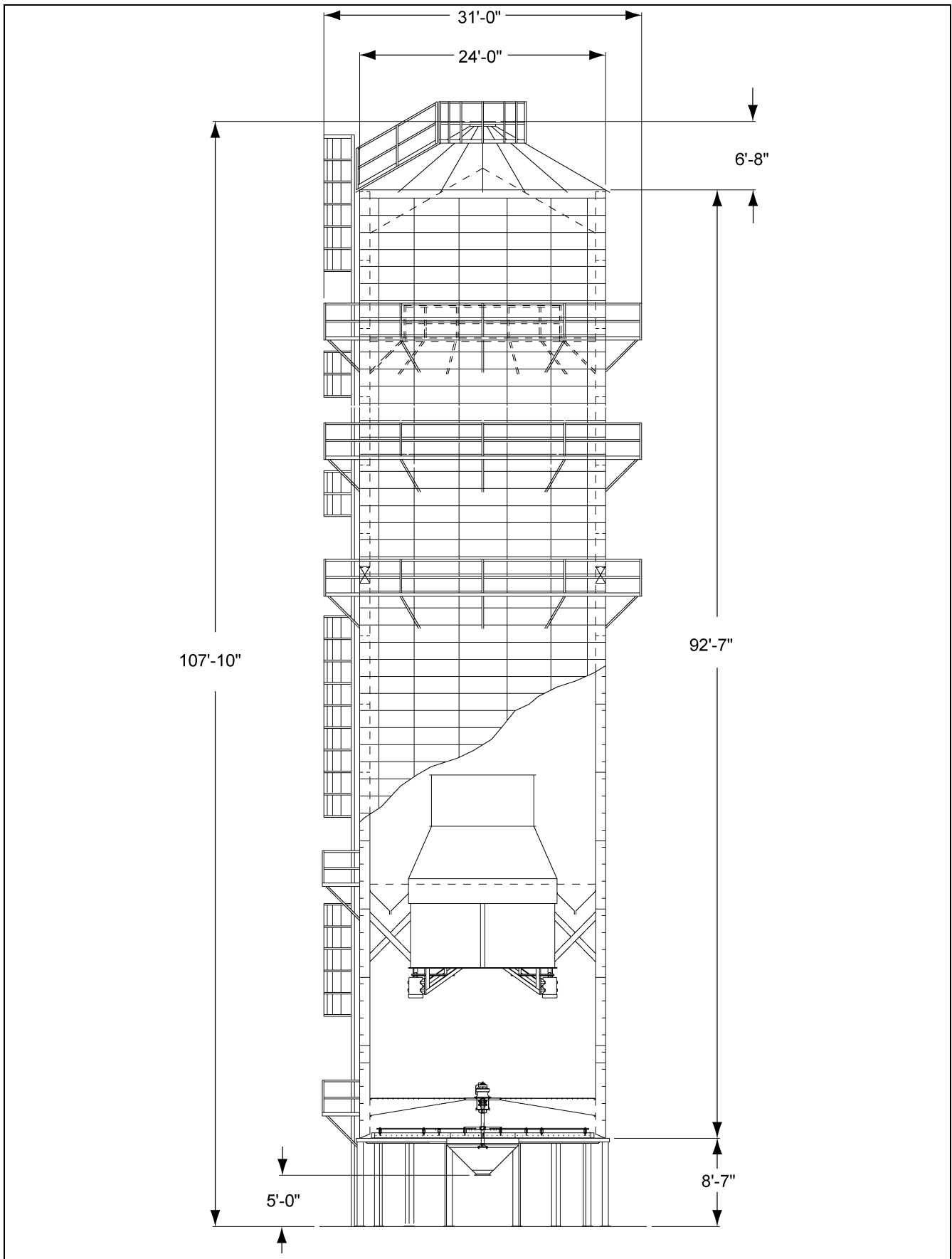

Figure 26EV Zimmerman Tower Dryer Model Z-6055

26. All Tower Dryer Models Drawings

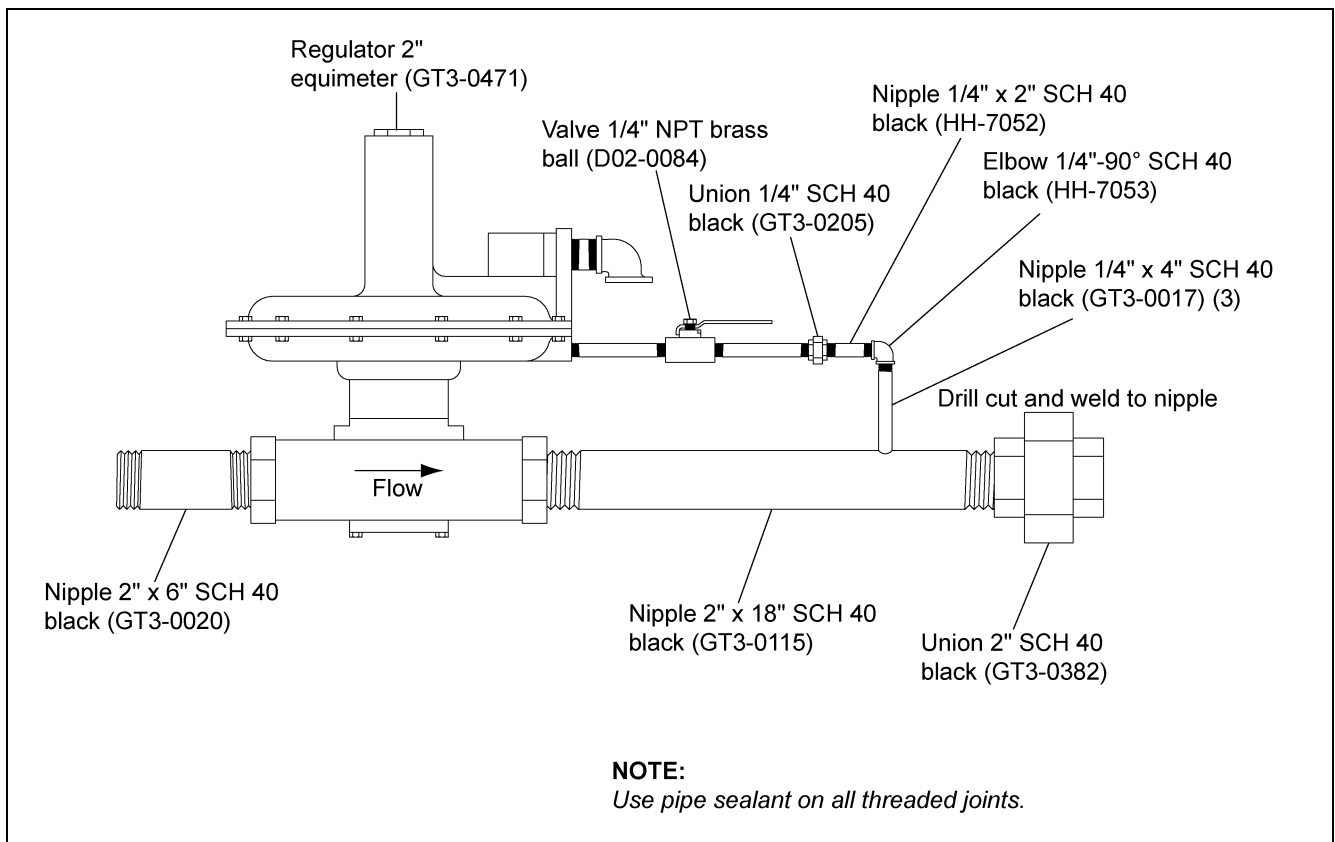

Figure 26EW 2" Regulator Section - Domestic

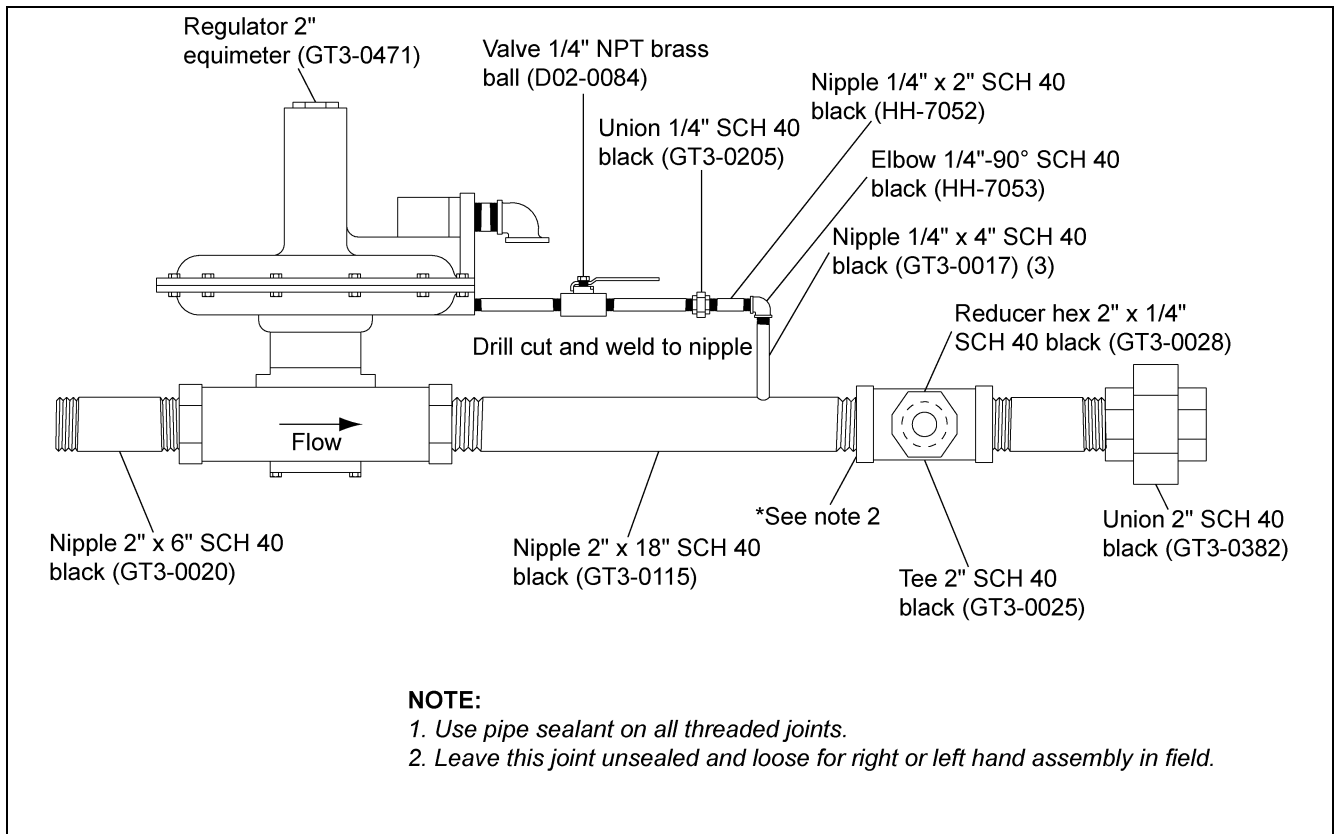

Figure 26EX 2" Regulator Section - Canadian

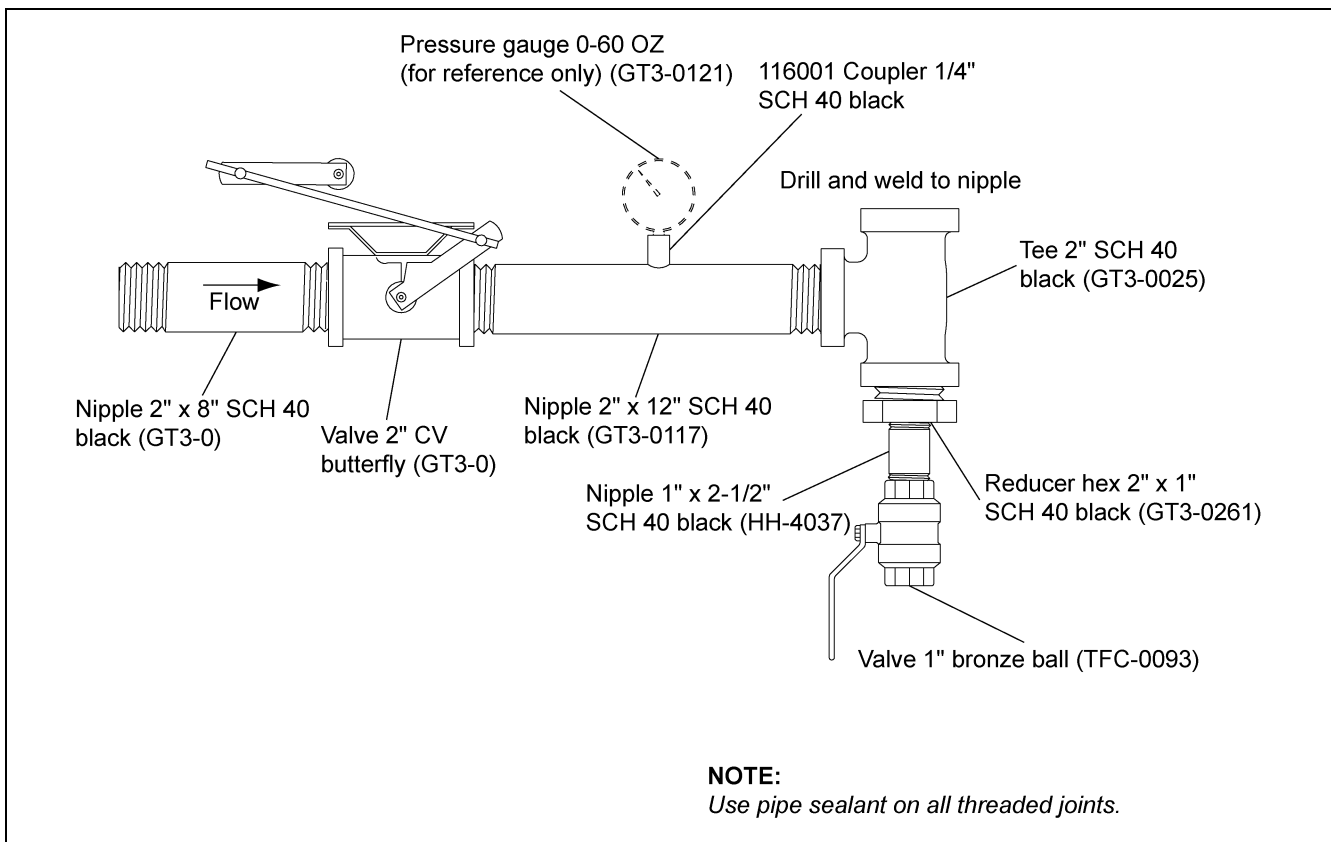

Figure 26EY 2" Modulator Section - Domestic

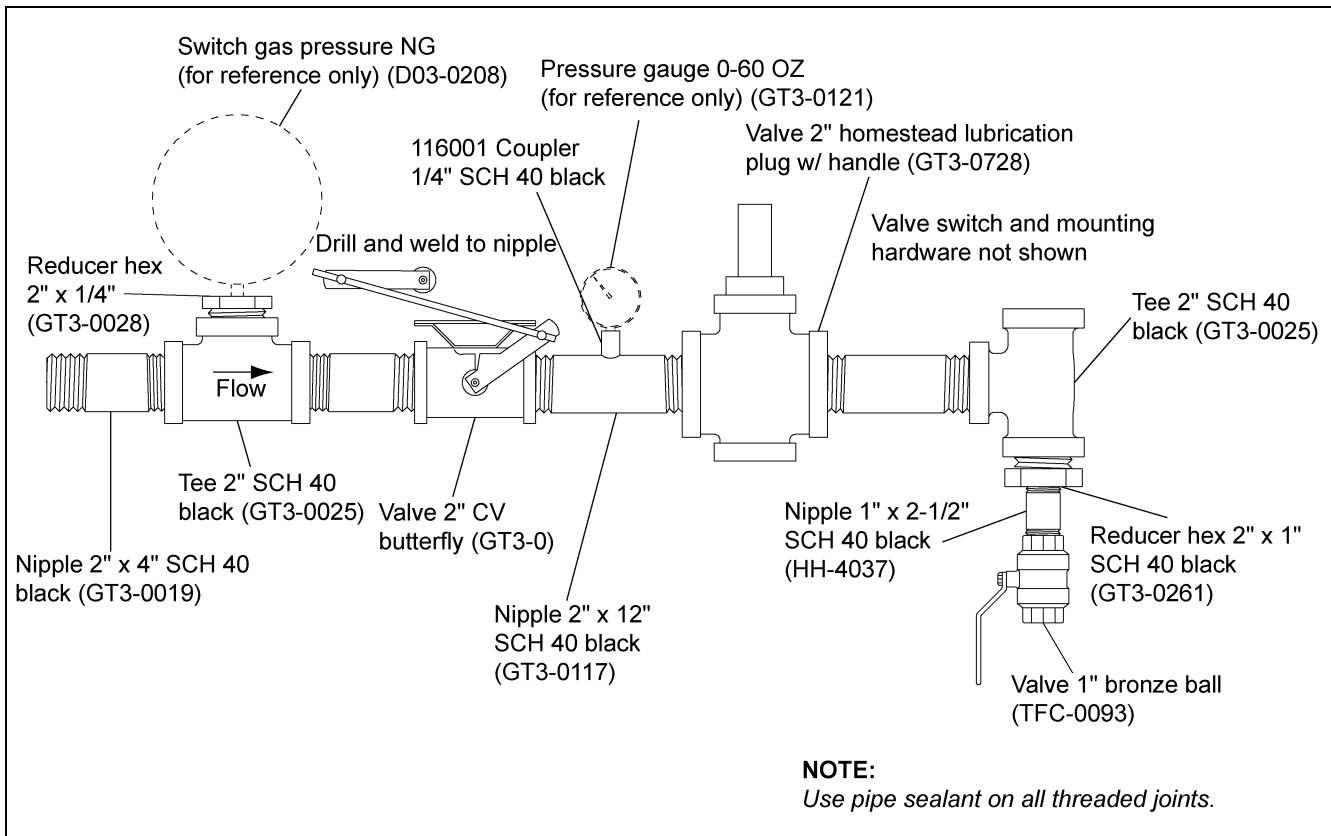

Figure 26EZ 2" Modulator Section - Canadian

26. All Tower Dryer Models Drawings

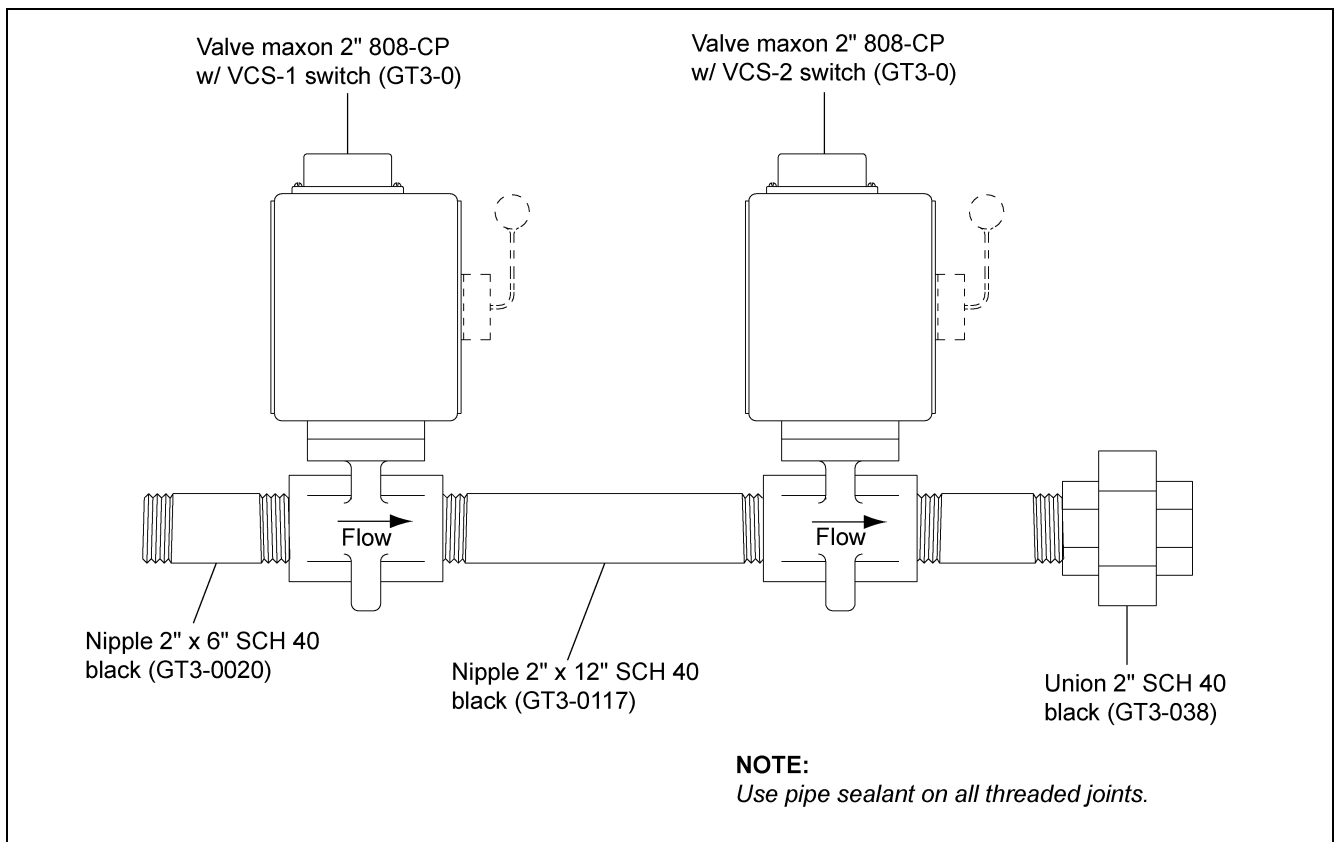

Figure 26FA 2" Maxon Section - Domestic

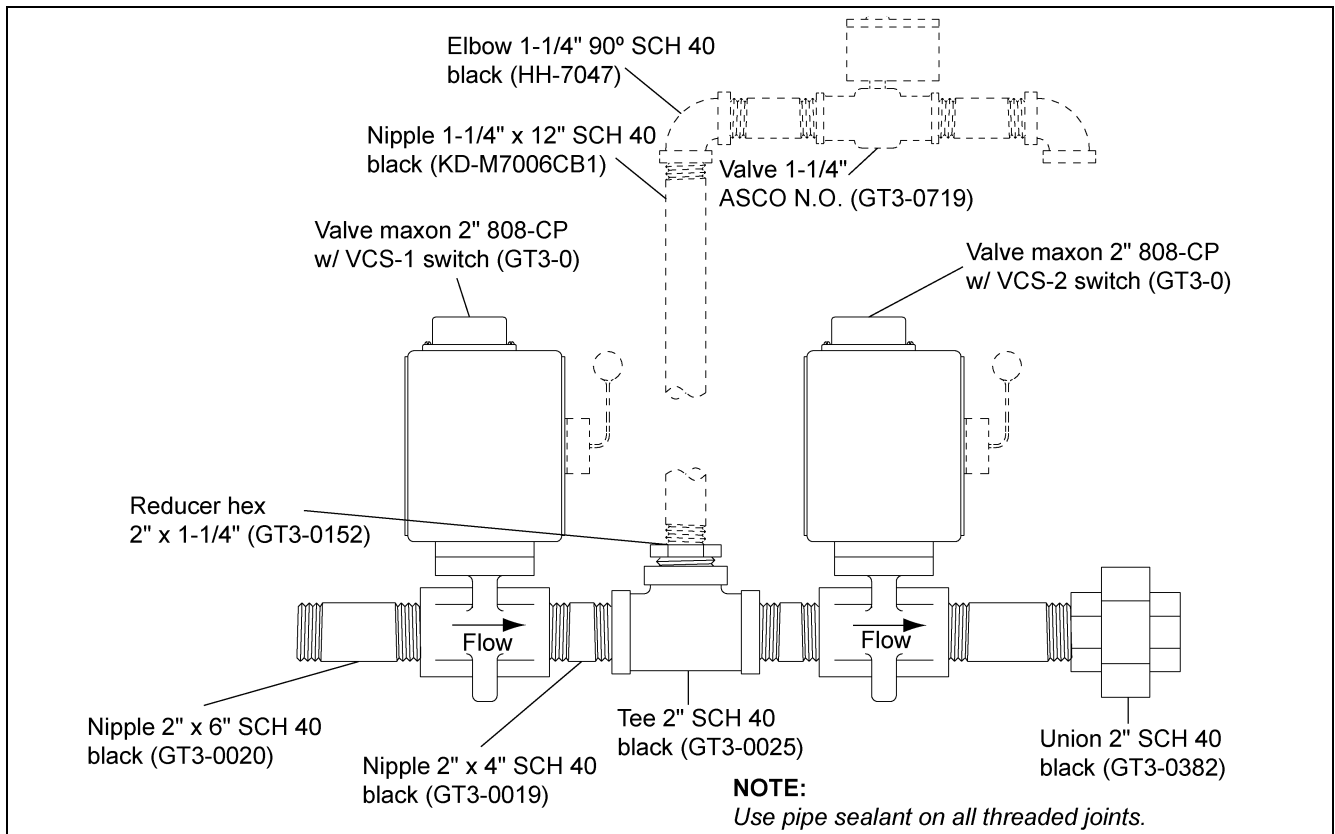

Figure 26FB 2" Maxon Section - Canadian

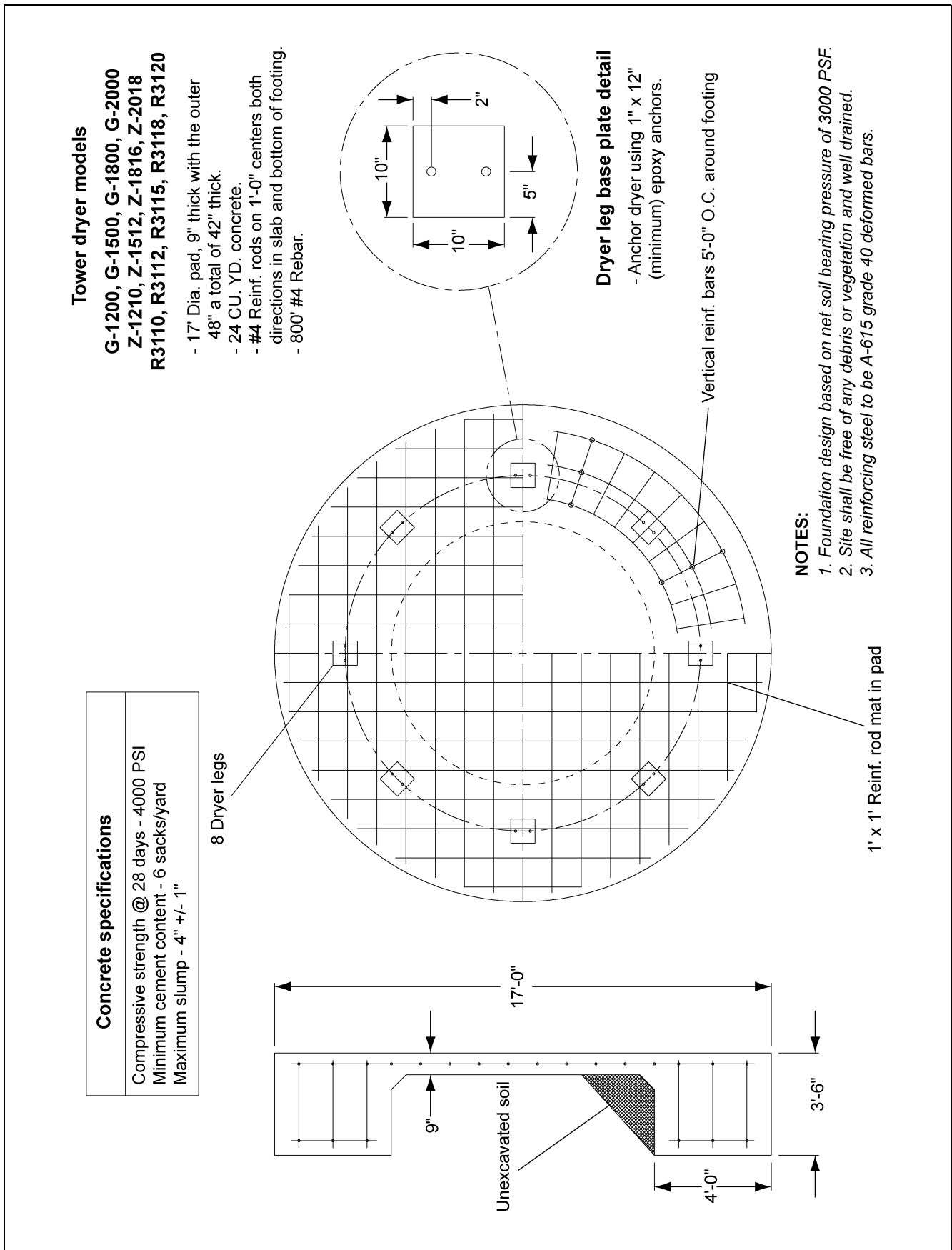

Figure 26FC Foundation Plan

26. All Tower Dryer Models Drawings

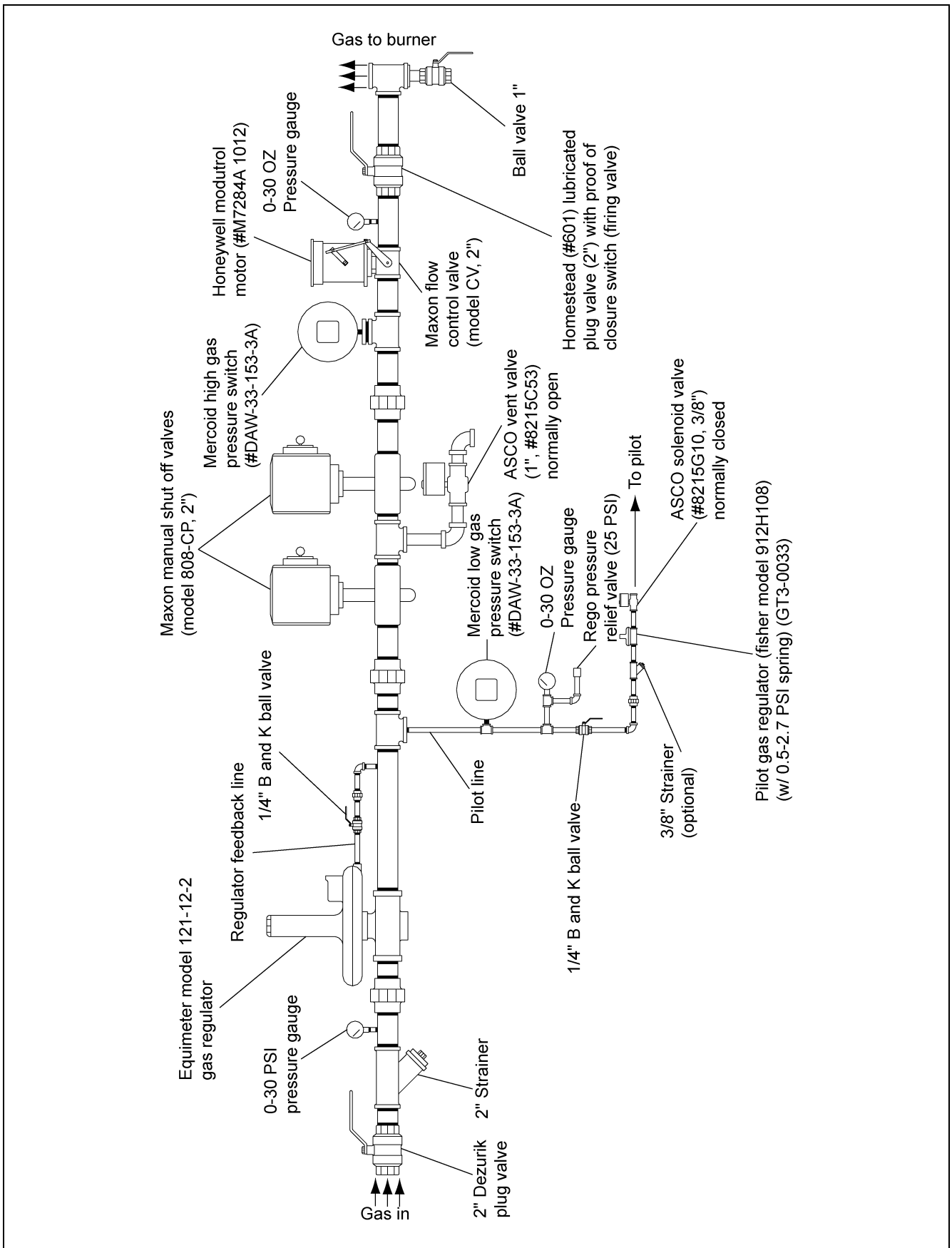

Figure 26FD Tower Dryer 2" Canadian Gas Train

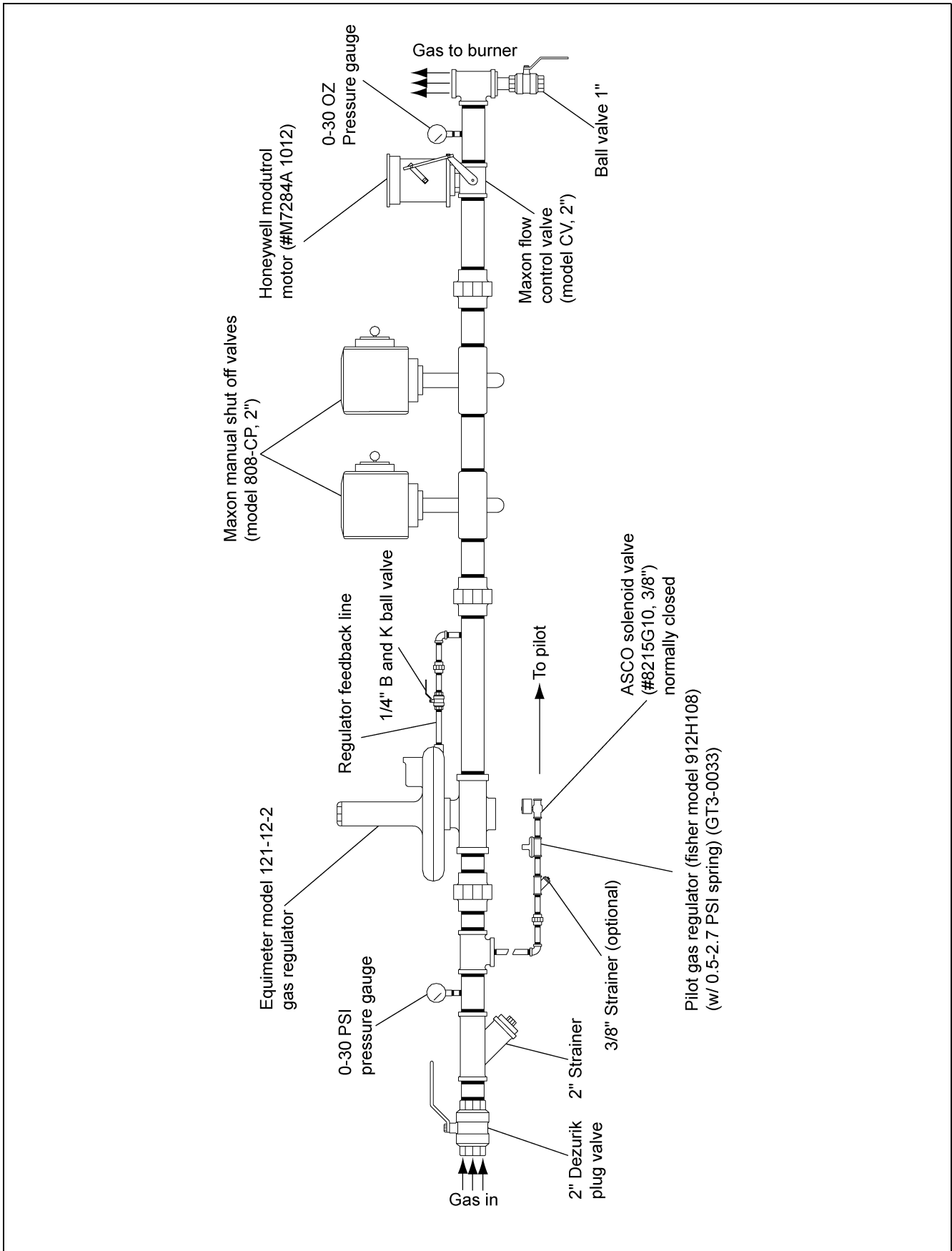

Figure 26FE Tower Dryer 2" Gas Train

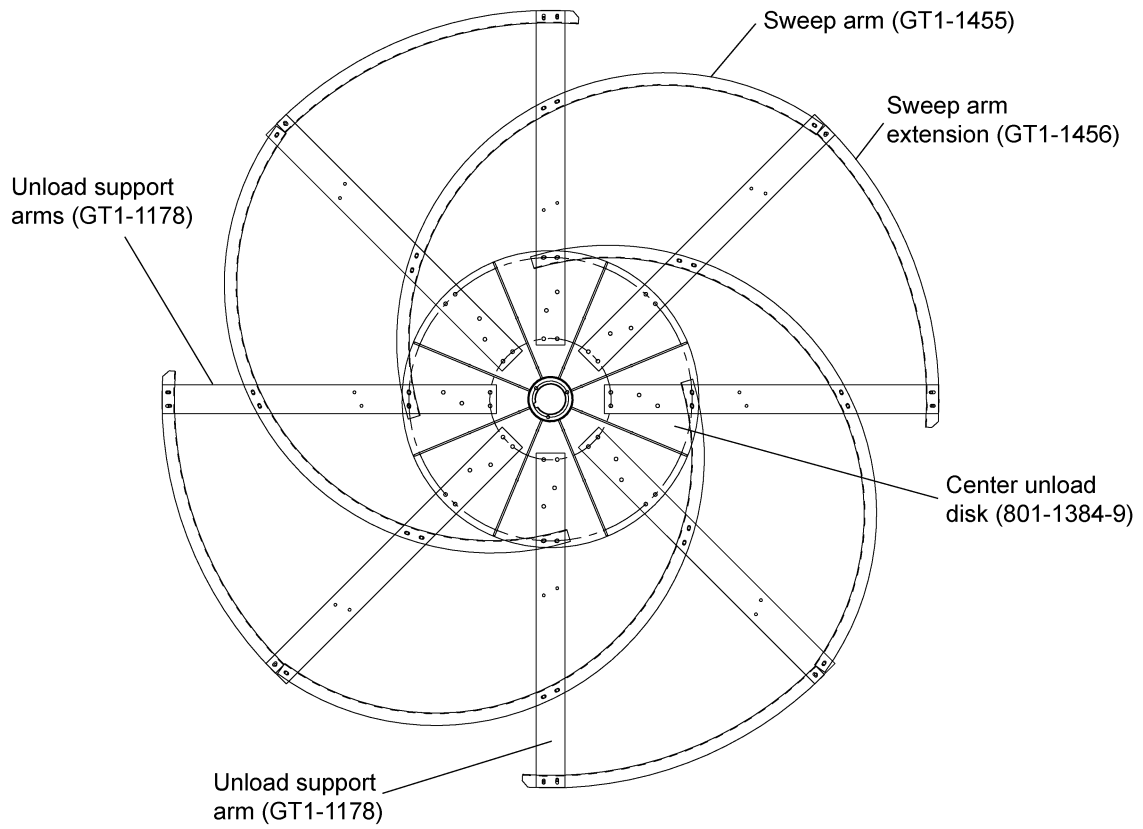

Figure 26FF 2006 Zimmerman 12' Sweep Unload

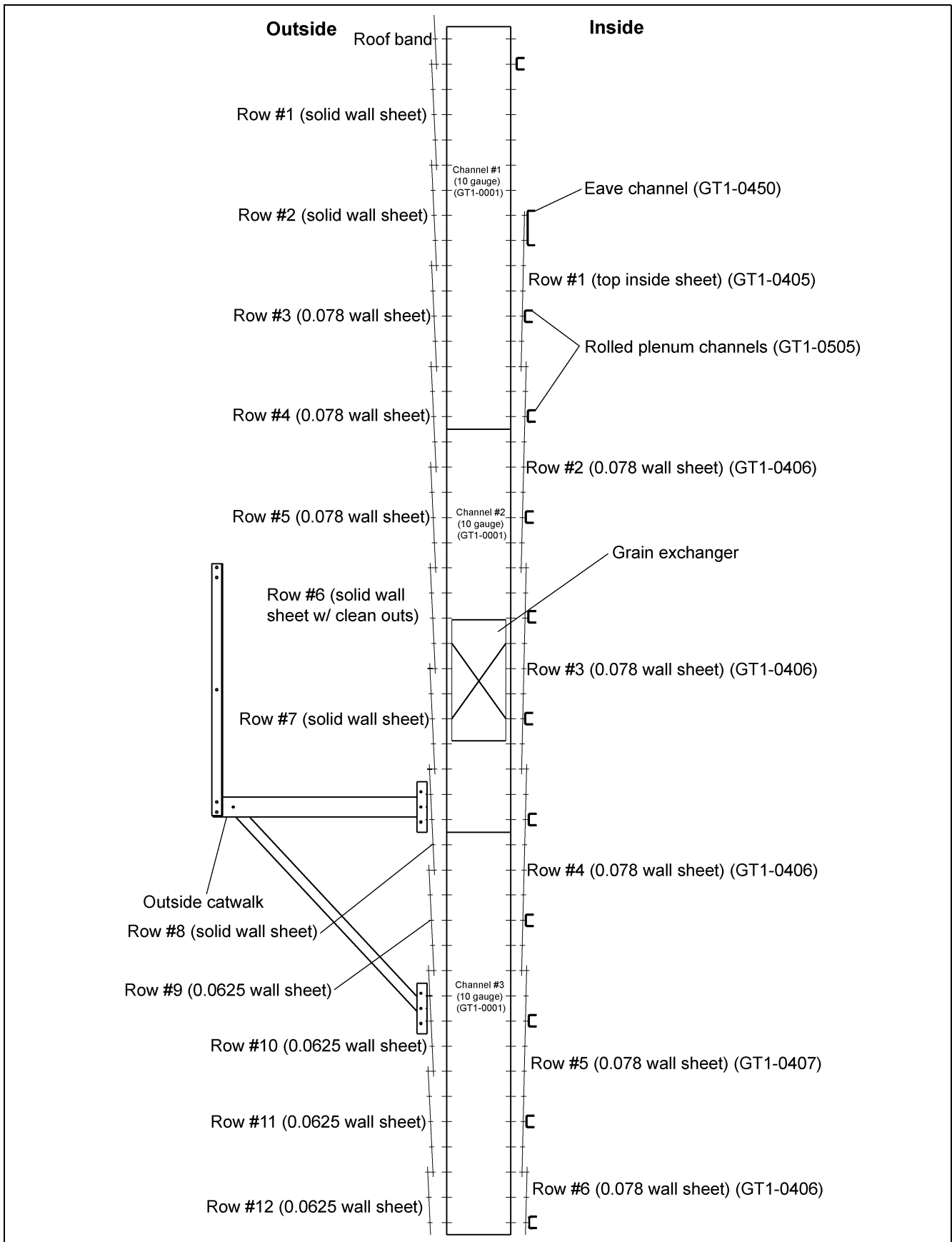

Figure 26FG Clip Placement Z-1210 Channels 1 to 3

26. All Tower Dryer Models Drawings

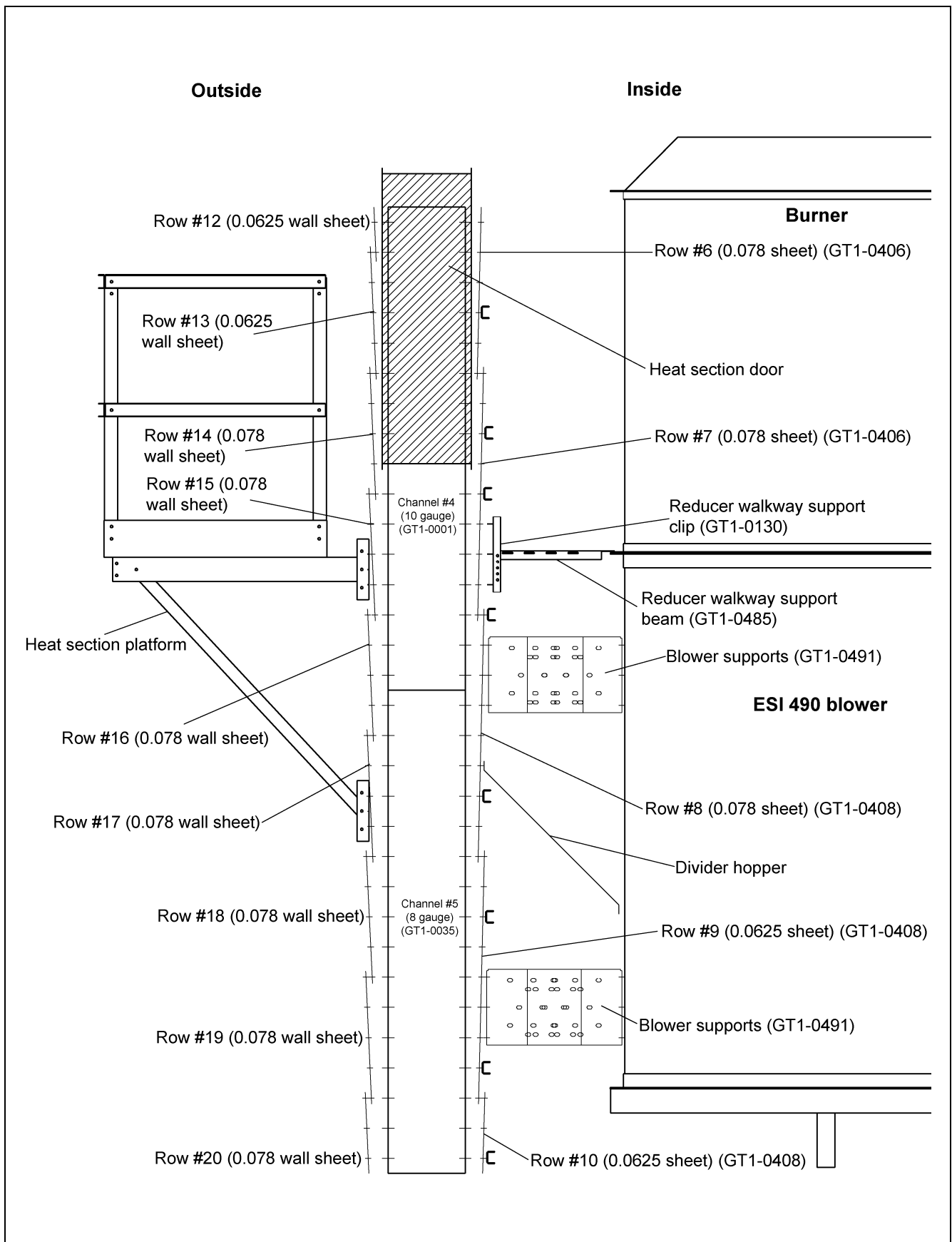

Figure 26FH Clip Placement Z-1210 Channels 4 to 5

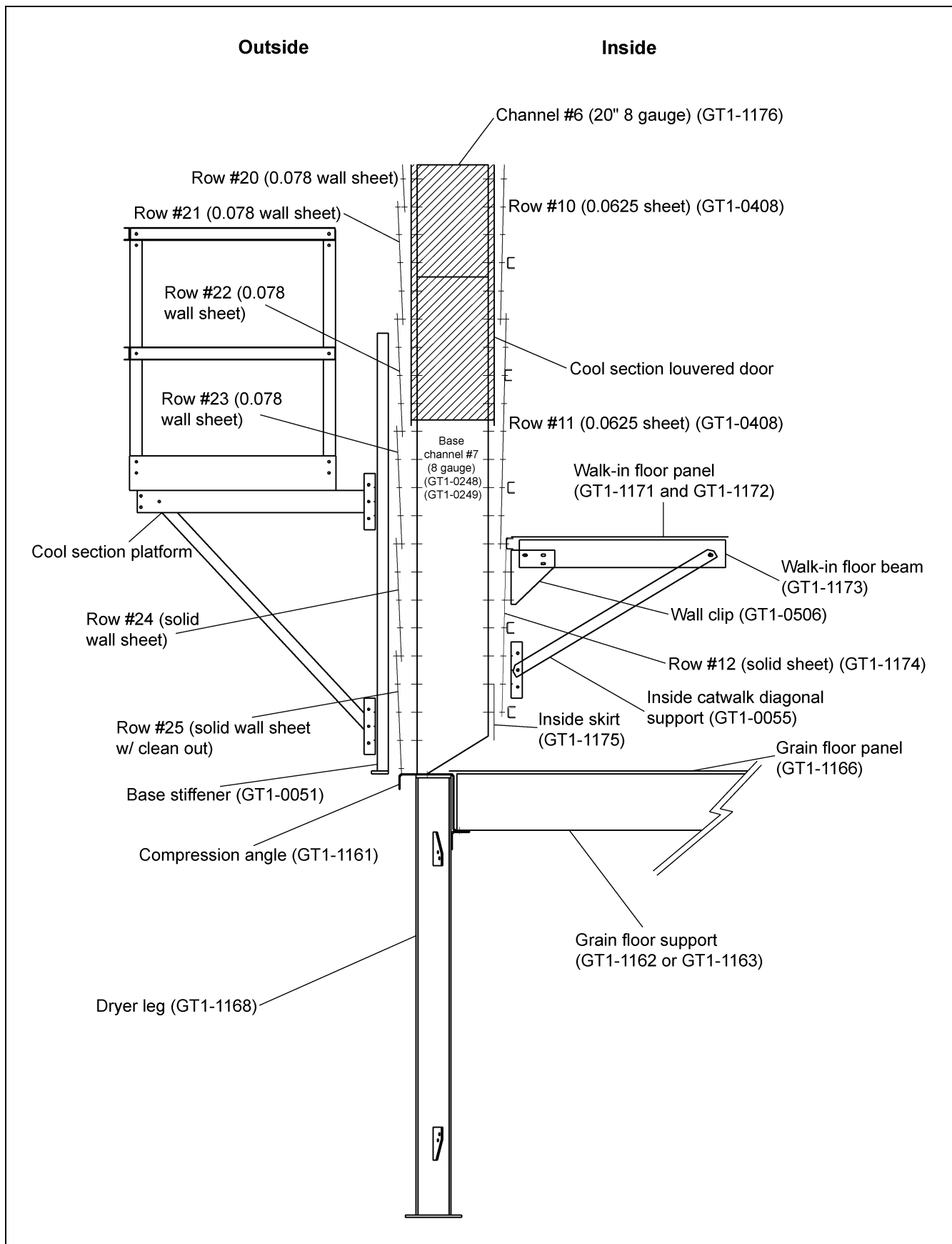

Figure 26FI Clip Placement Z-1210 Channels 6 to 7

26. All Tower Dryer Models Drawings

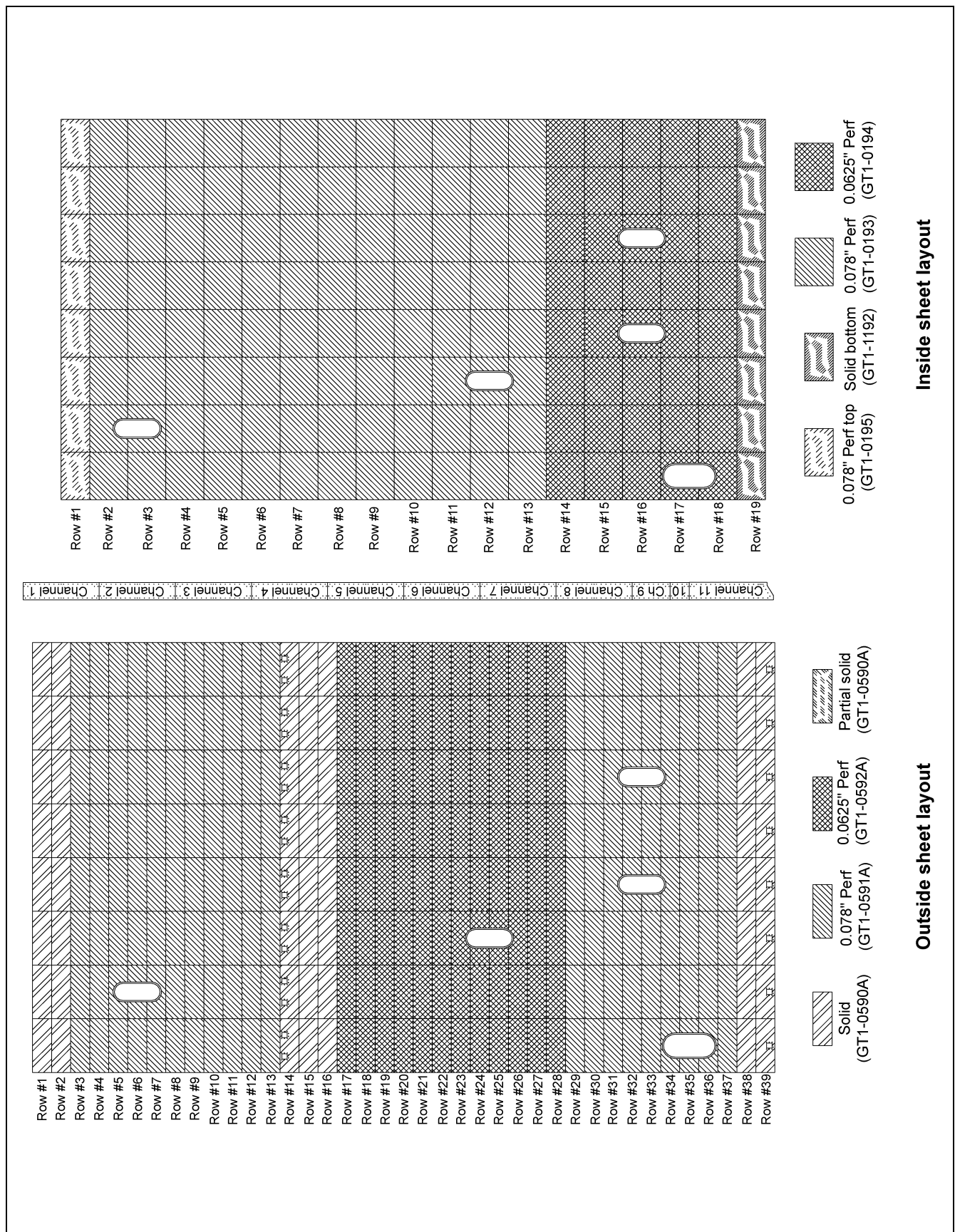

Figure 26FJ Z-2018/R3120 Sheet Layout

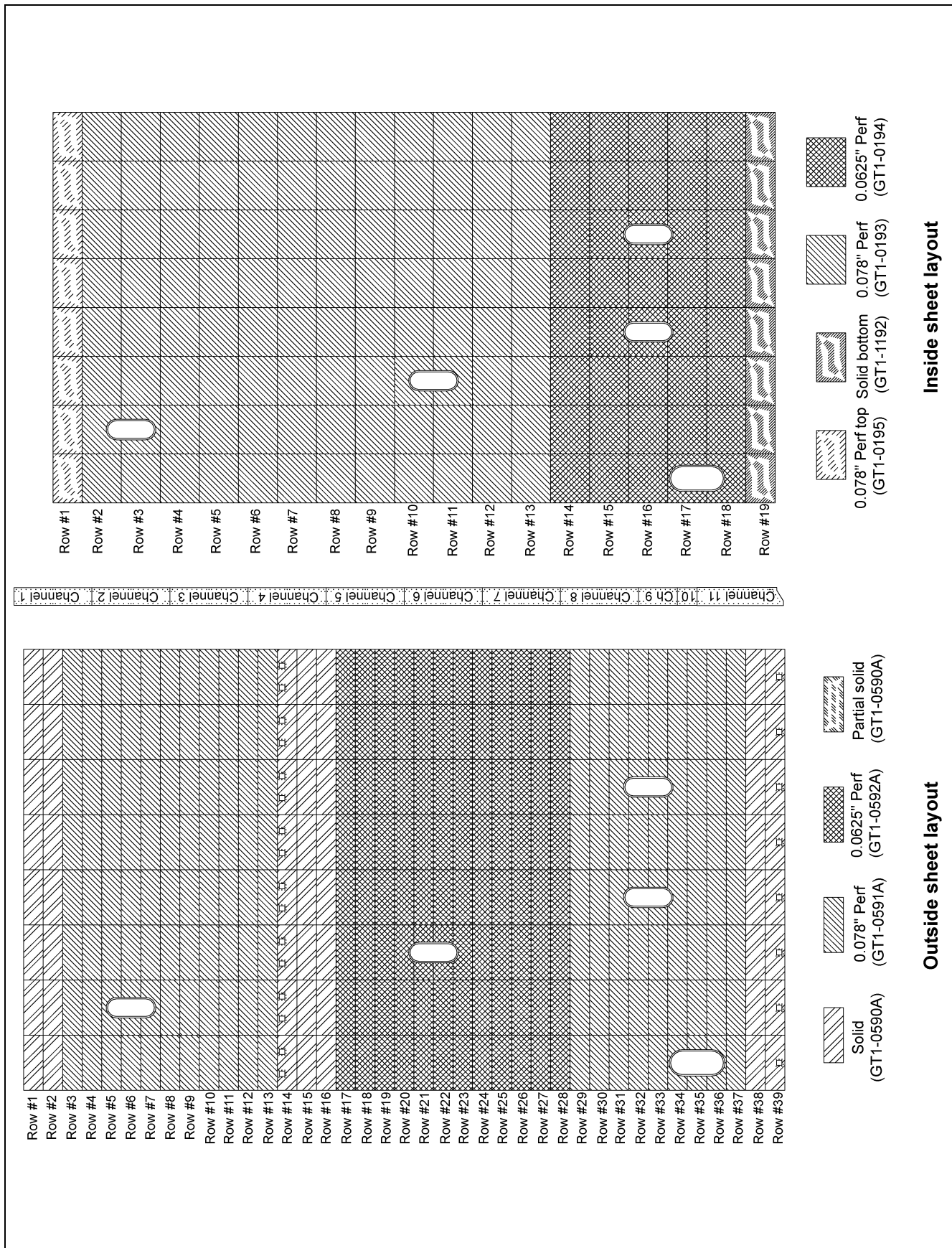

Figure 26FK Z-2018/R3120 Sheet Layout (2005)

26. All Tower Dryer Models Drawings

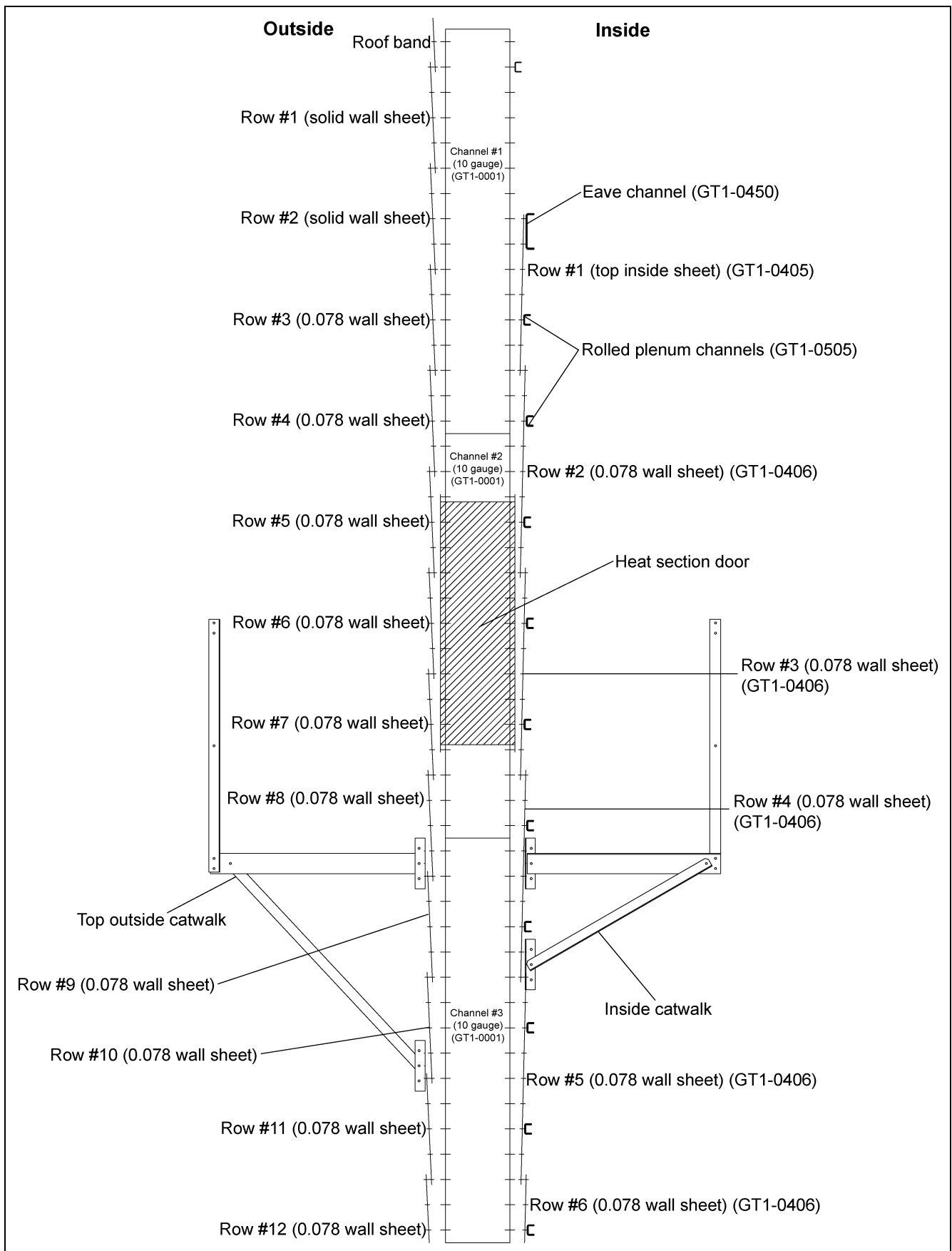

Figure 26FL Clip Placement Z-2018/R3120 Channels 1 to 3

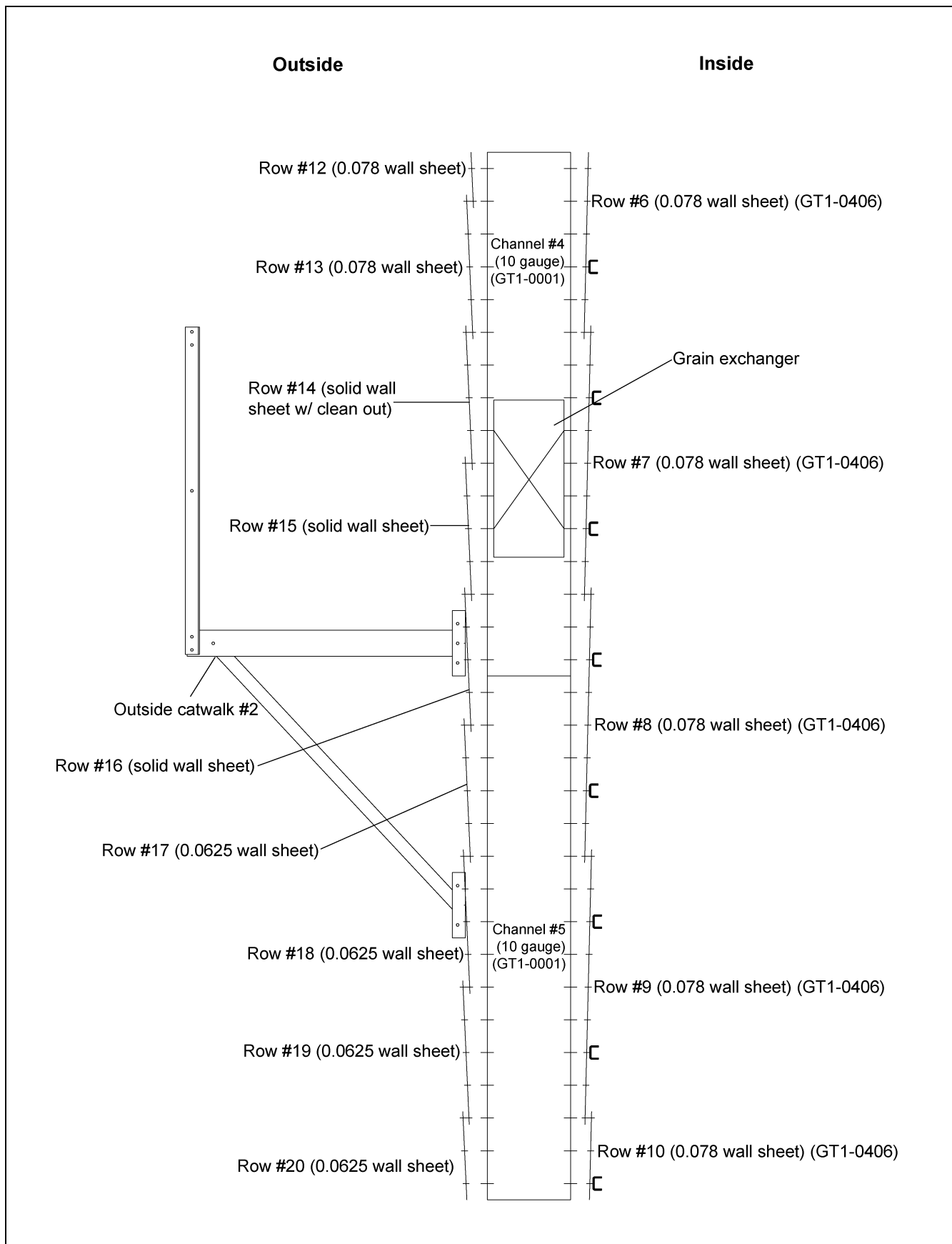

Figure 26FM Clip Placement Z-2018/R3120 Channels 4 to 5

26. All Tower Dryer Models Drawings

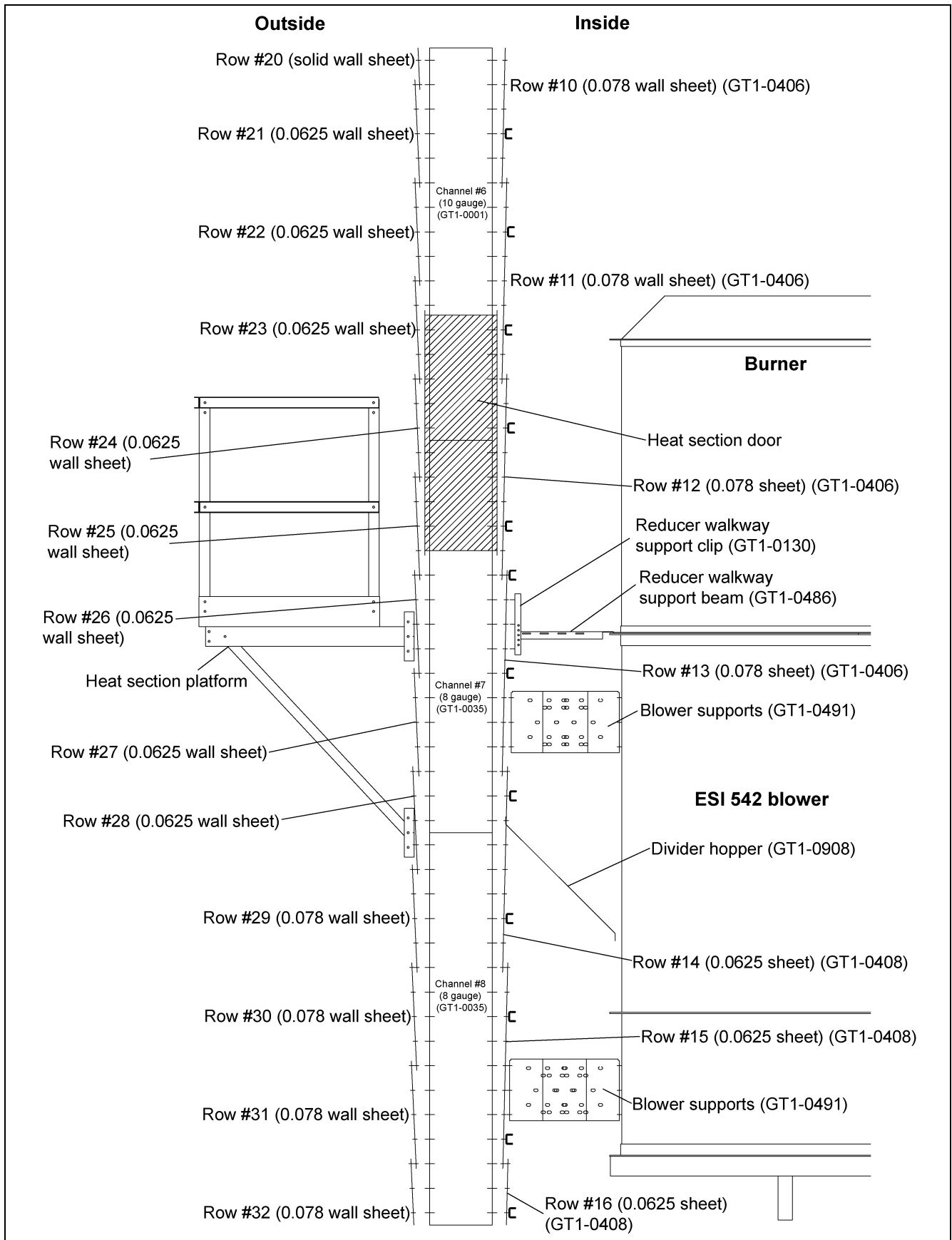

Figure 26FN Clip Placement Z-2018 Channels 6 to 8

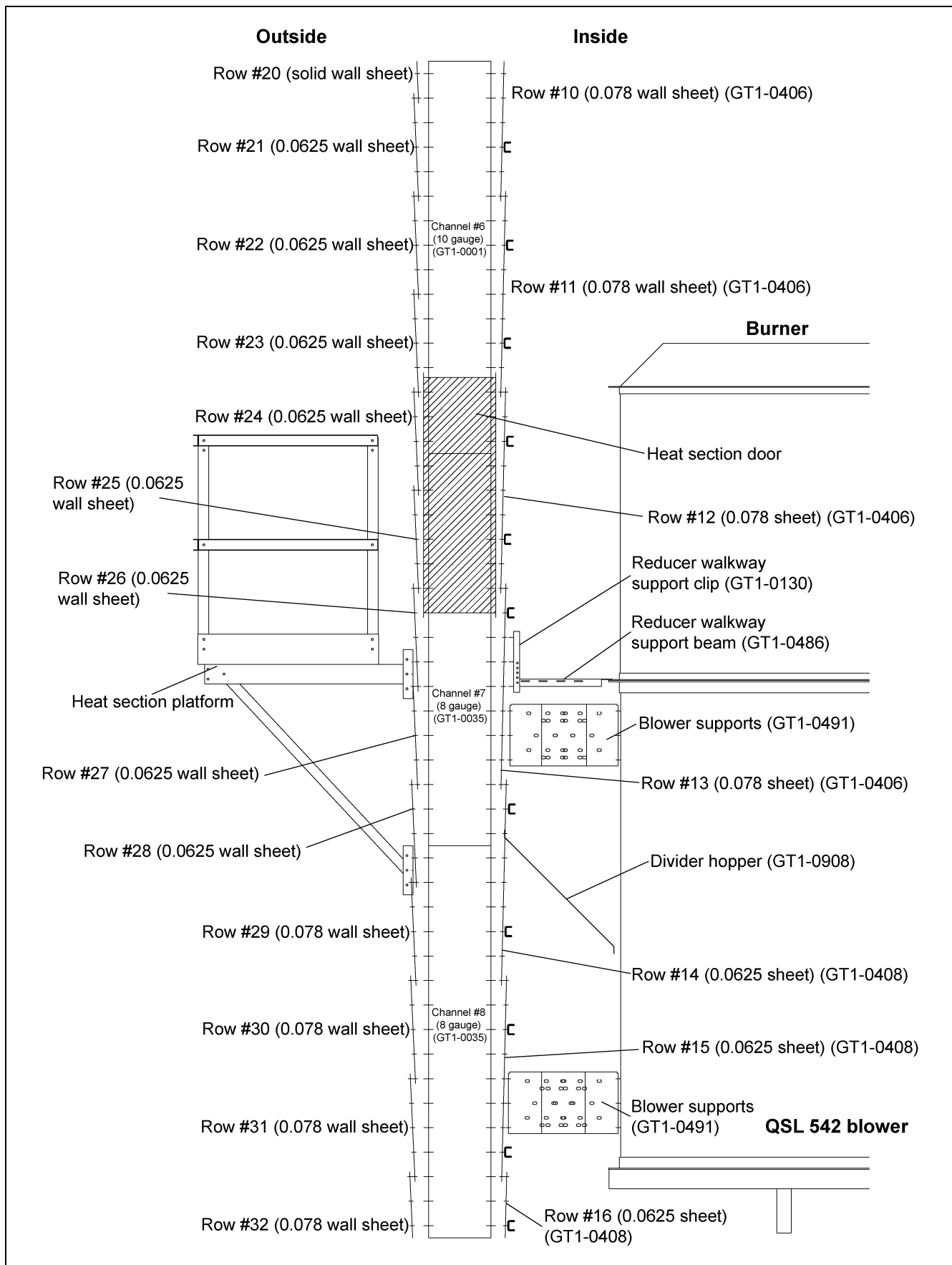

Figure 26FO Clip Placement Z-2018/R3120 w/ QSL Blower Channels 6 to 8

26. All Tower Dryer Models Drawings

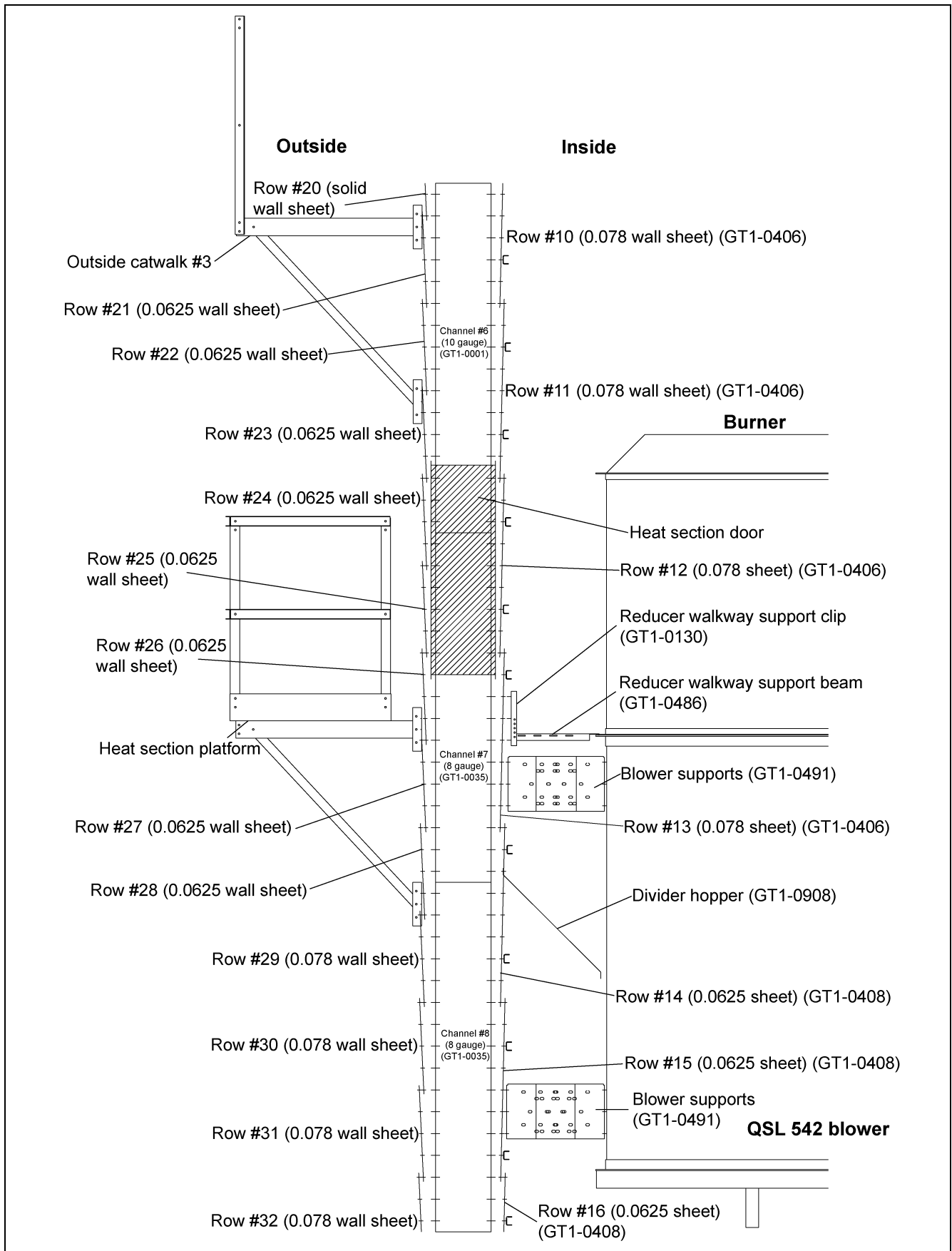

Figure 26FP Clip Placement Z-2018/R3120 w/ QSL Blower Channels 6 to 8

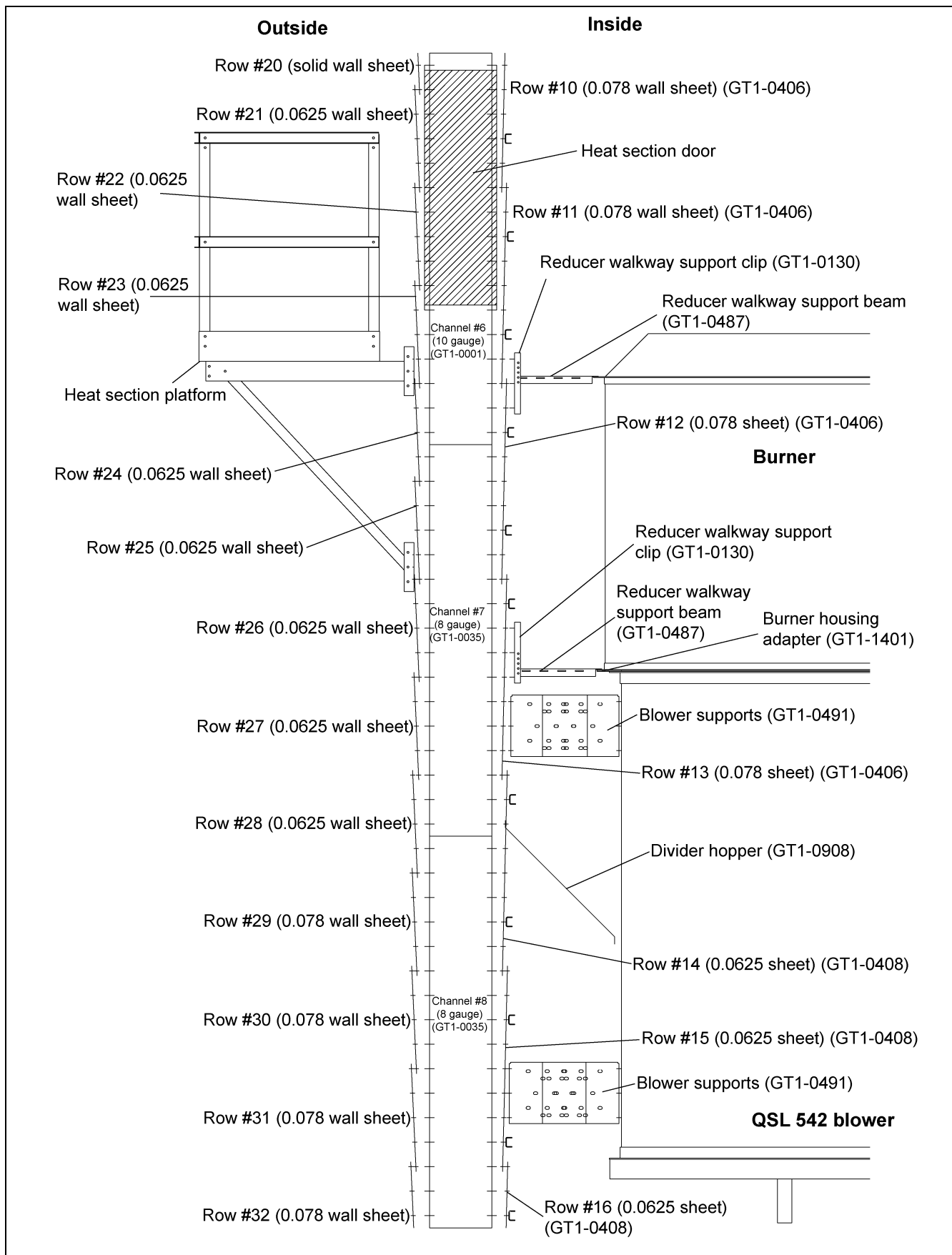

Figure 26FQ Clip Placement Z-2018/R3120 w/ QSL Blower Channels 6 to 8 (2005)

26. All Tower Dryer Models Drawings

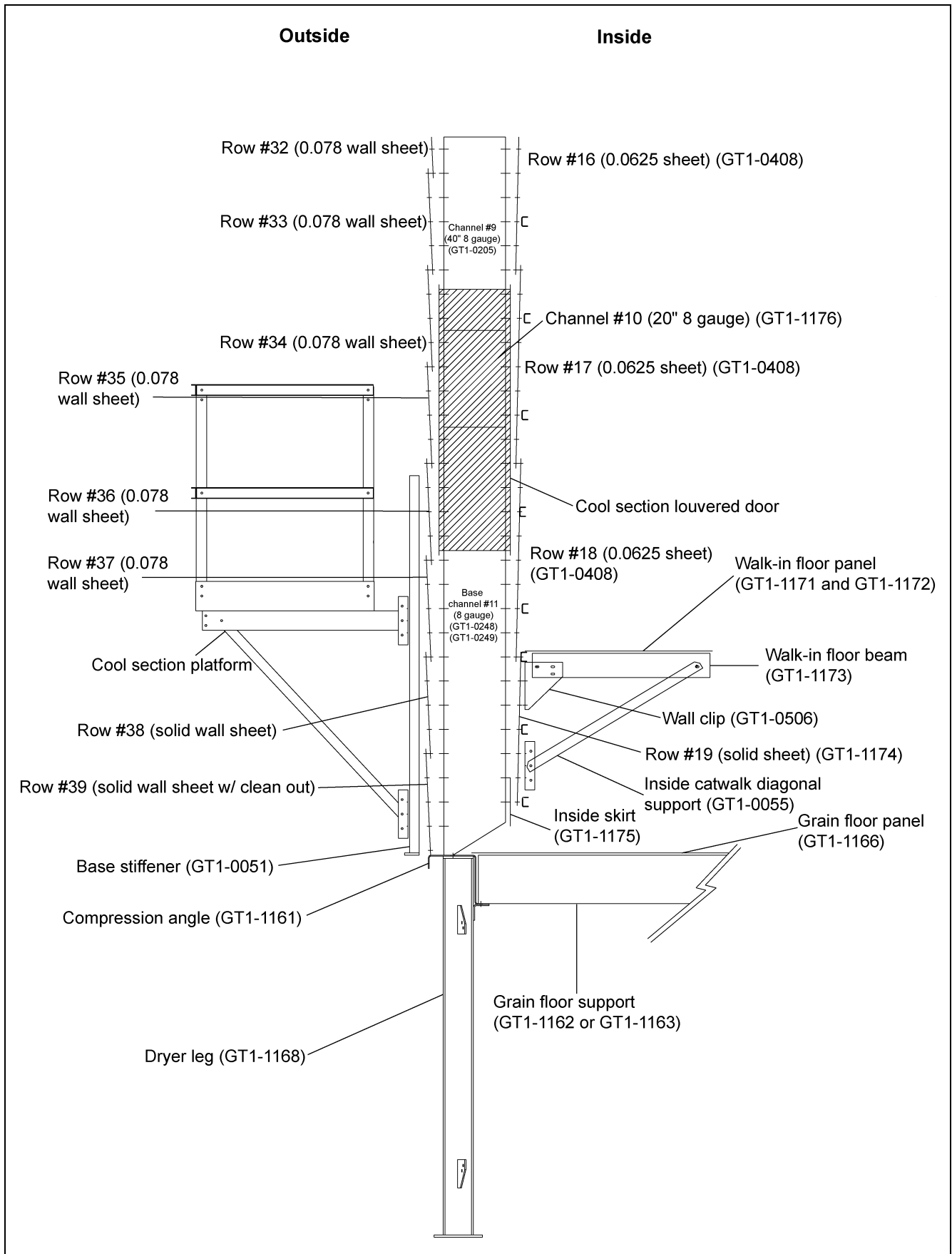

Figure 26FR Clip Placement Z-2018/R3120 Channels 9 to 11

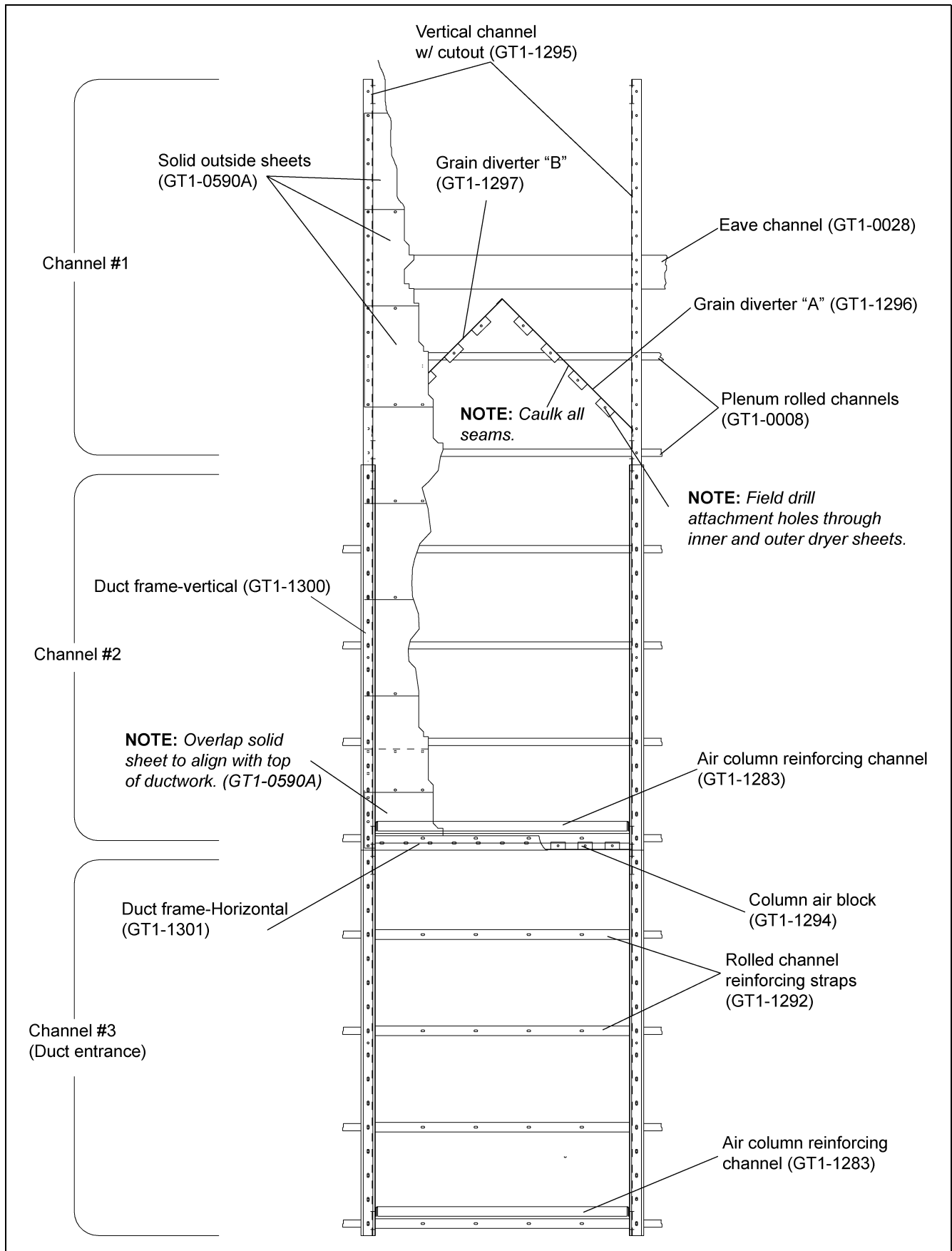

Figure 26FS Ductwork Dryer Column ECR3120

26. All Tower Dryer Models Drawings

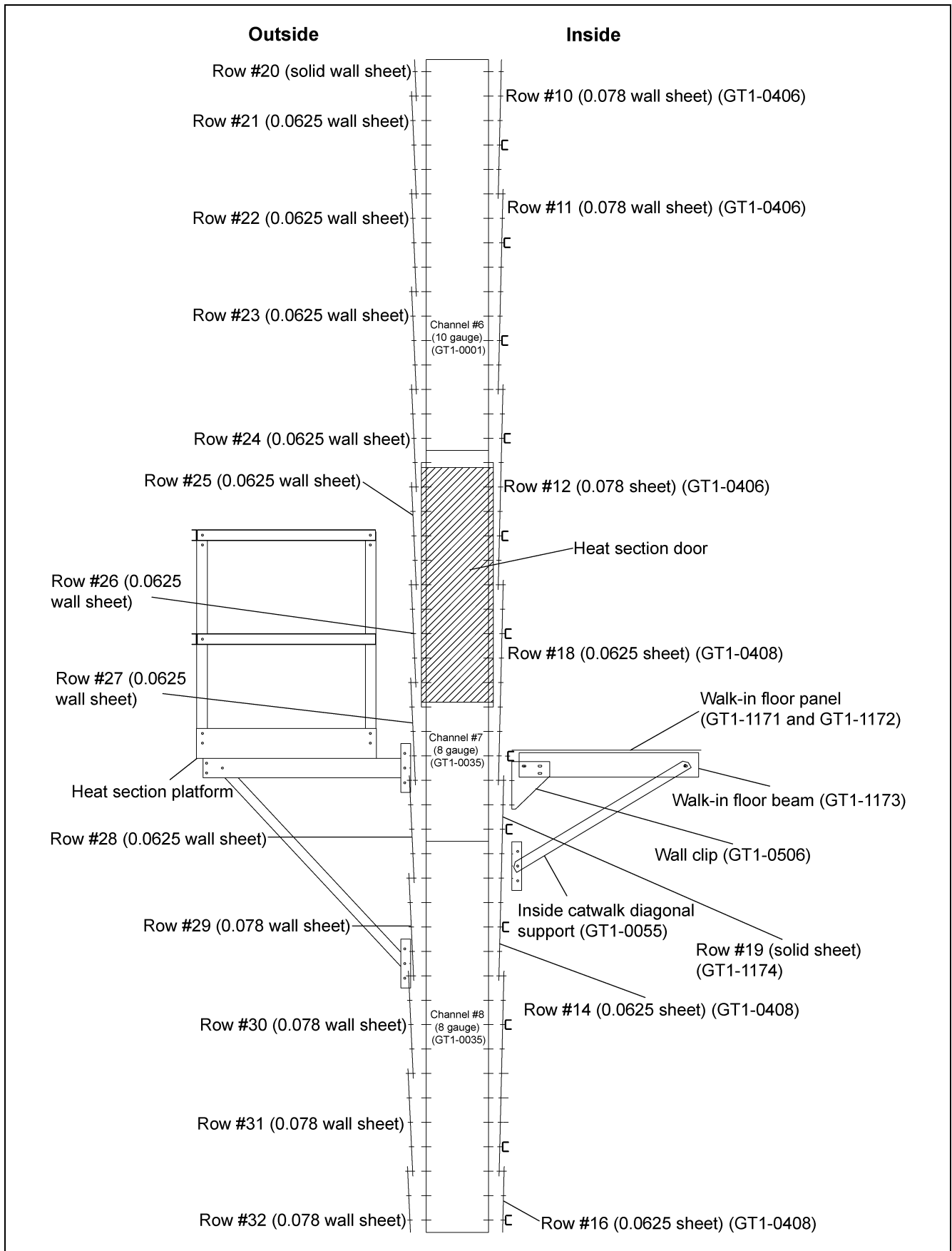

Figure 26FT Clip Placement ECR3120 Channels 6 to 8

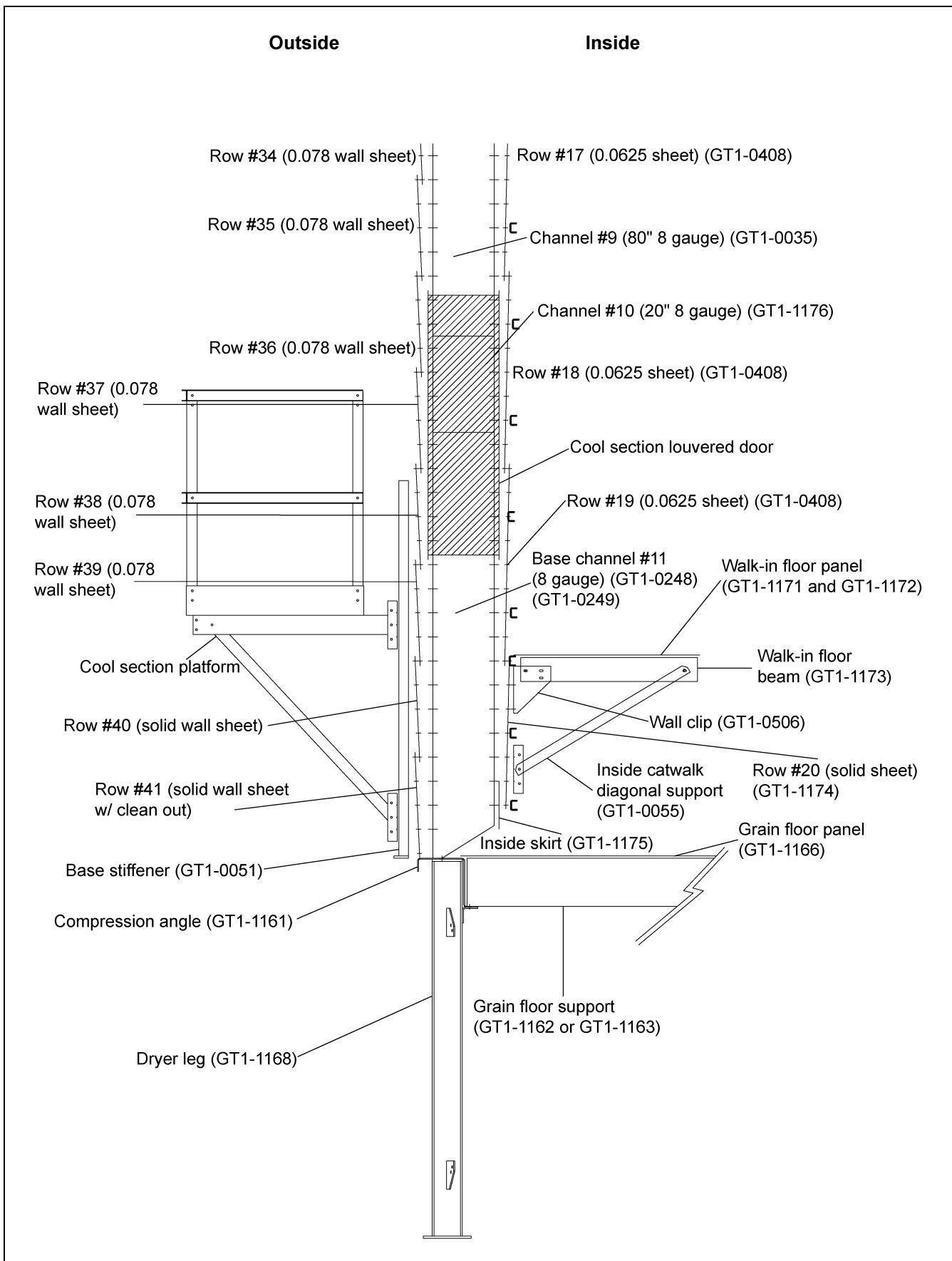

Figure 26FU Clip Placement ECR3120 Channels 9 to 11

26. All Tower Dryer Models Drawings

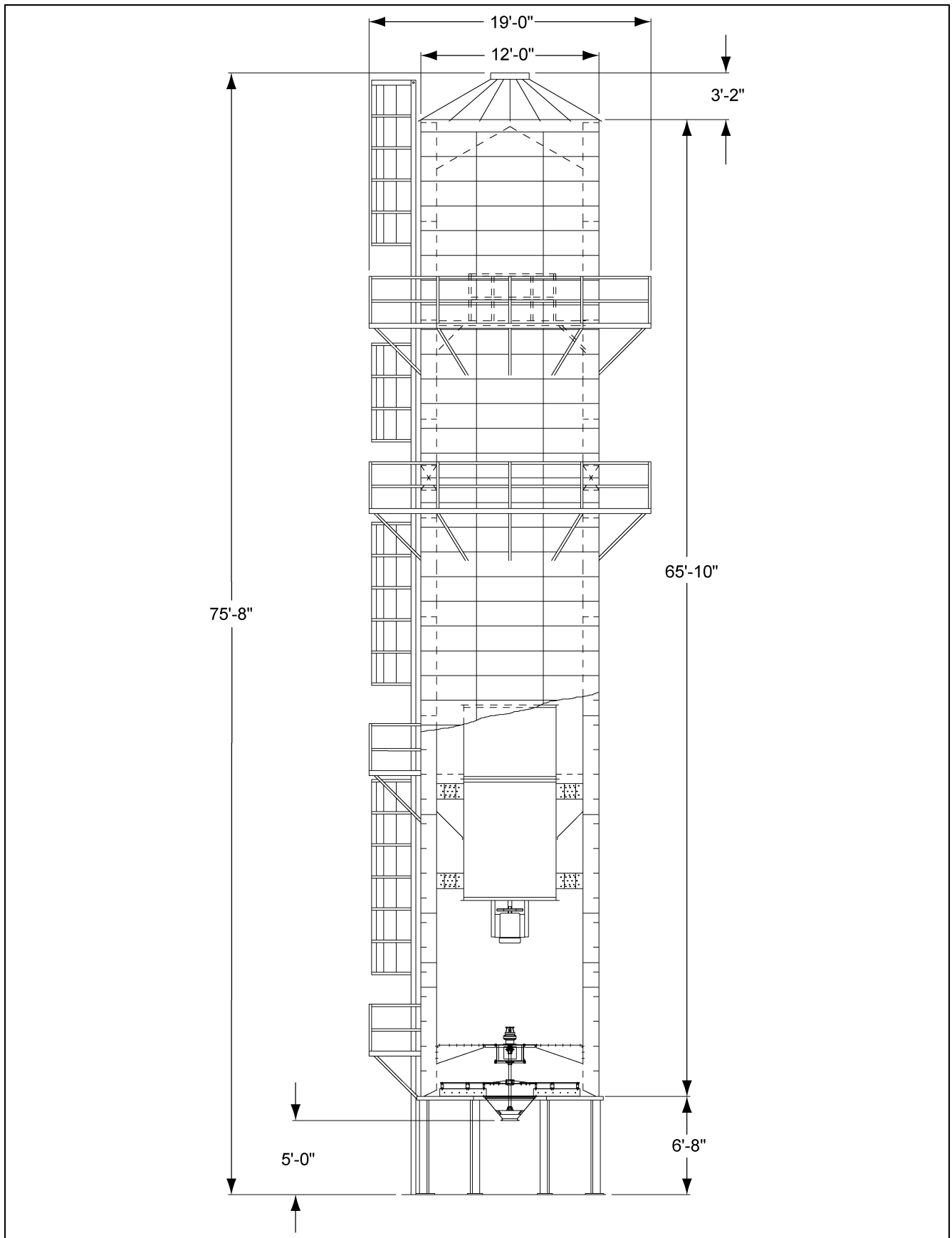

Figure 26FV Zimmerman Tower Dryer Model Z-2018

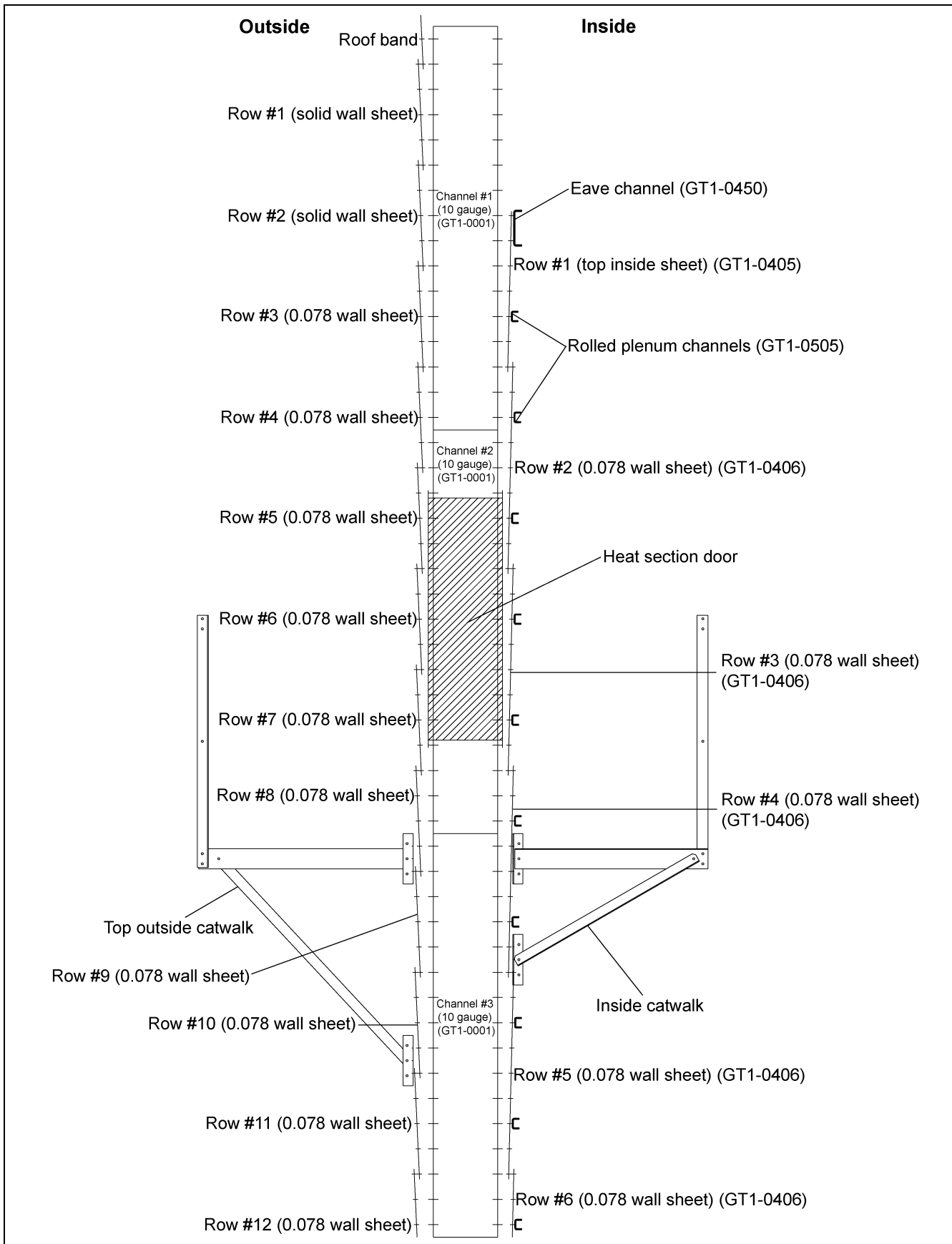

Figure 26FW Clip Placement G-1800 Channels 1 to 3

26. All Tower Dryer Models Drawings

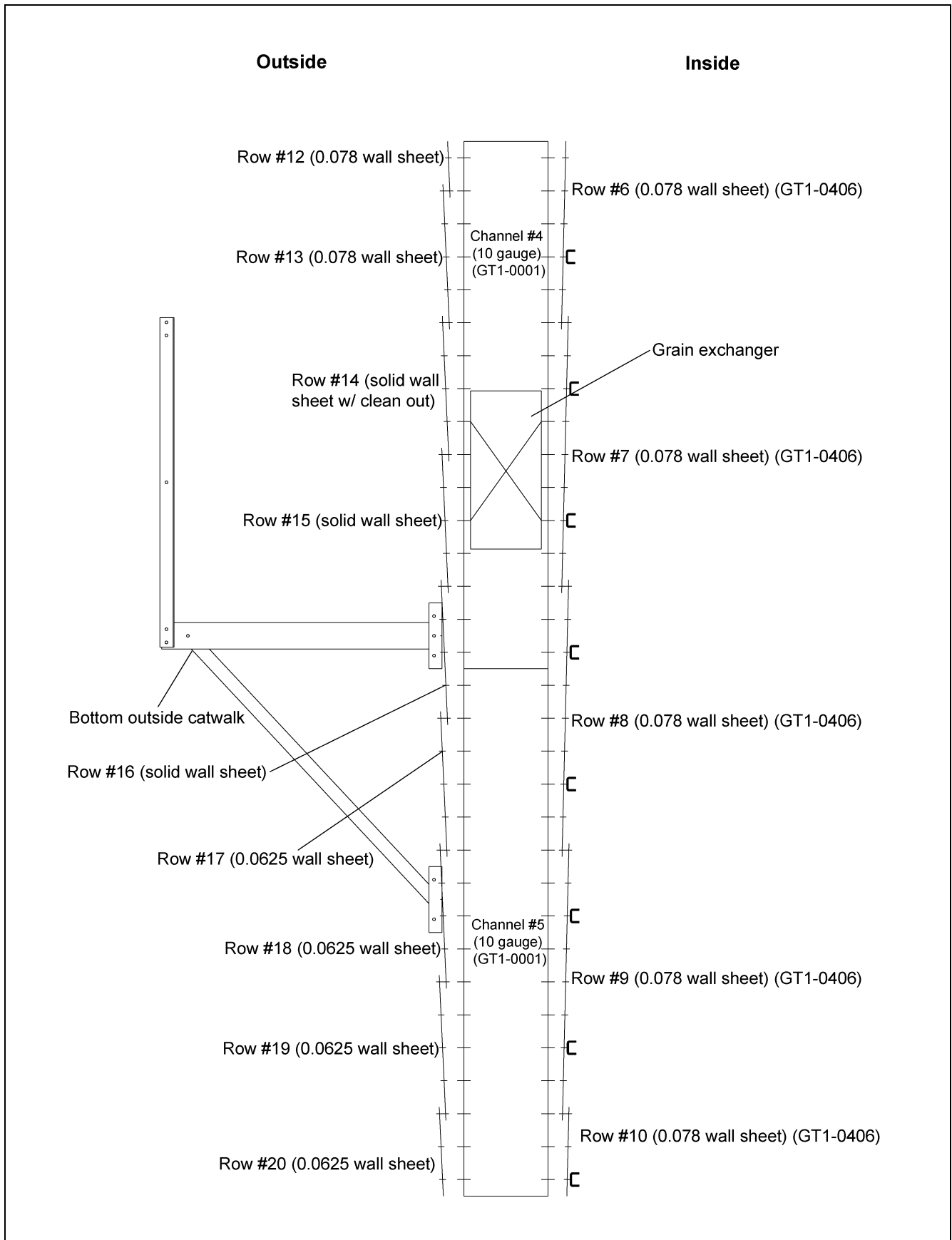

Figure 26FX Clip Placement G-1800 Channels 4 to 5

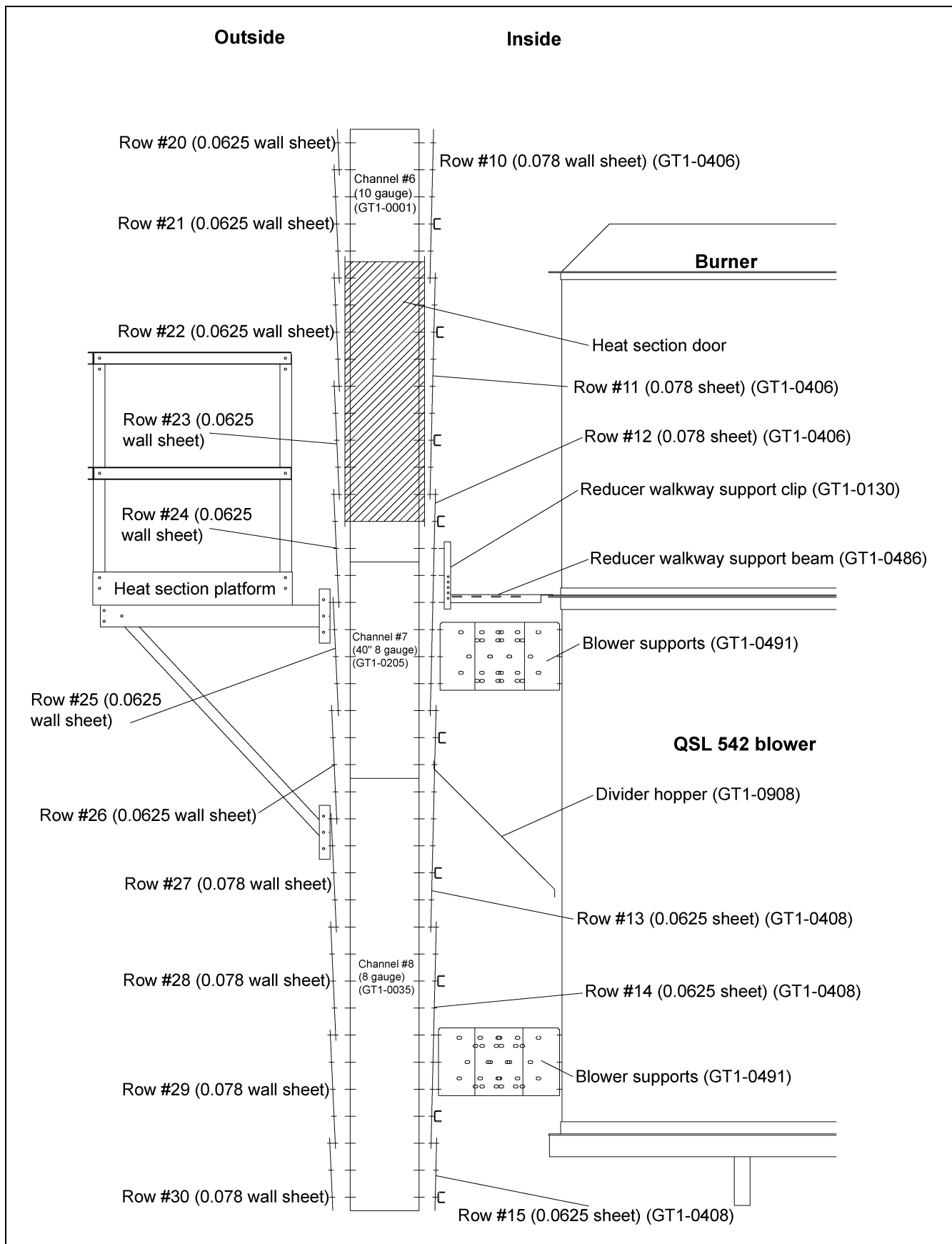

Figure 26FY Clip Placement Z-1800 Channels 6 to 8

26. All Tower Dryer Models Drawings

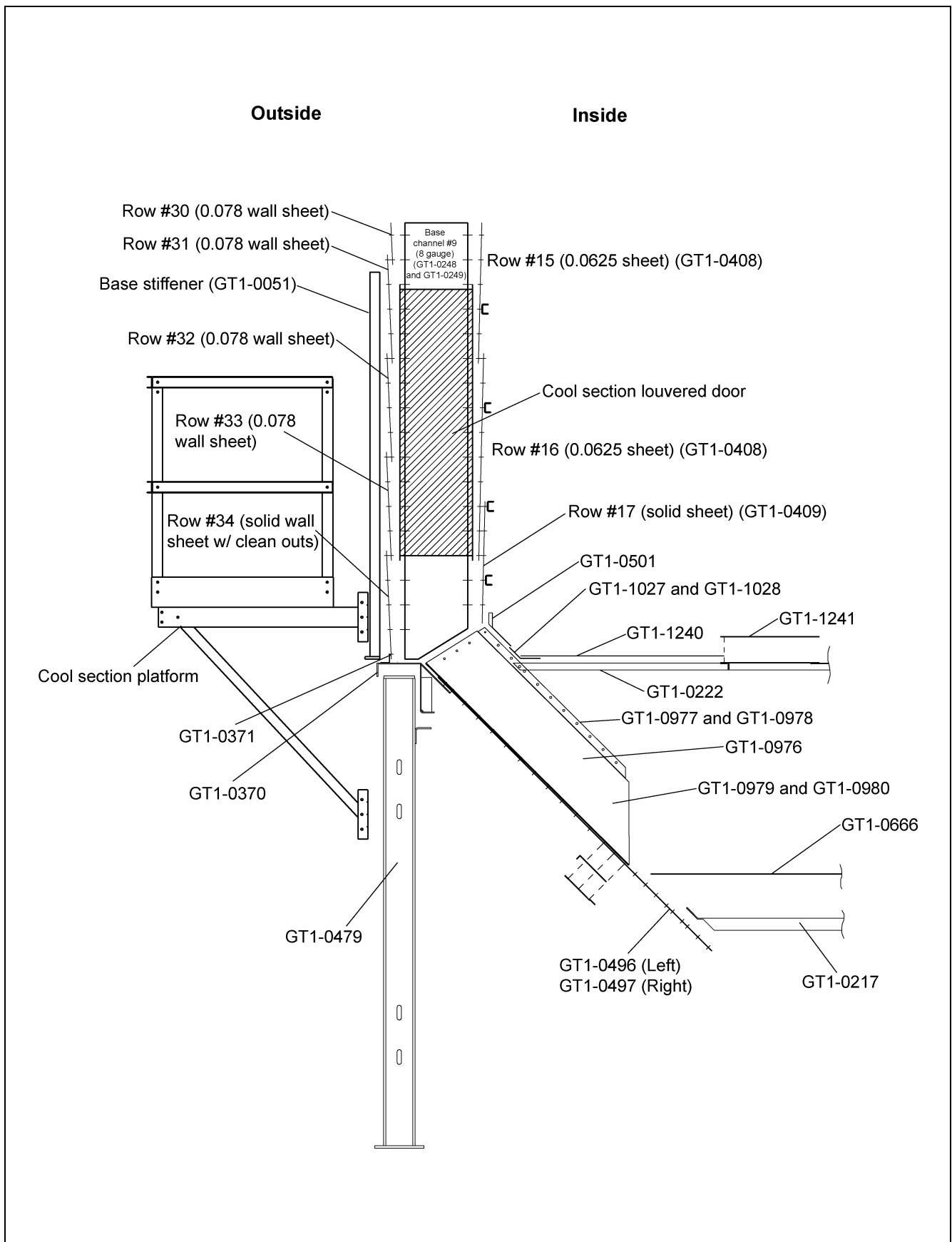

Figure 26FZ Clip Placement G-1800 Channel 9

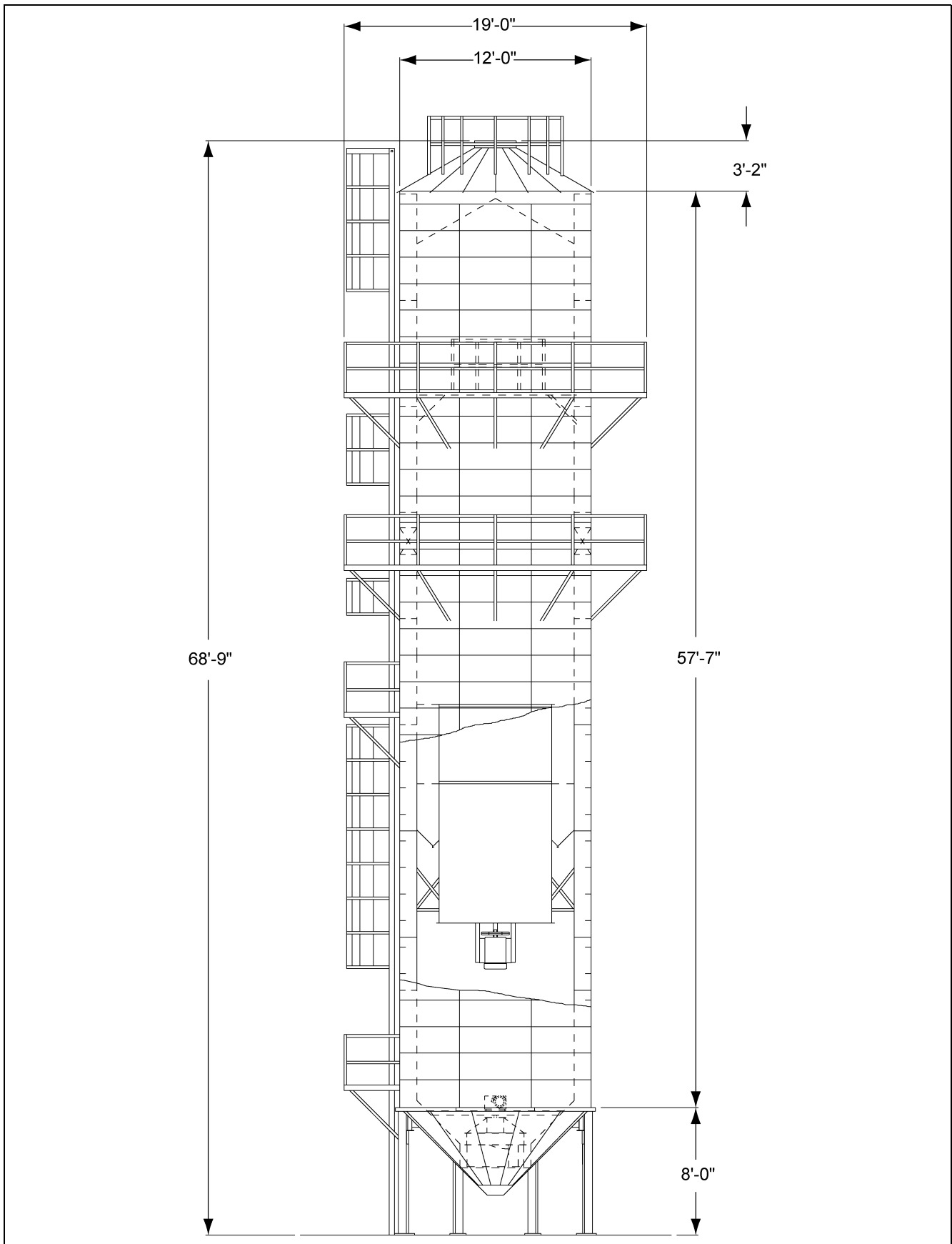

Figure 26GA GSI Tower Dryer Model 1800

26. All Tower Dryer Models Drawings

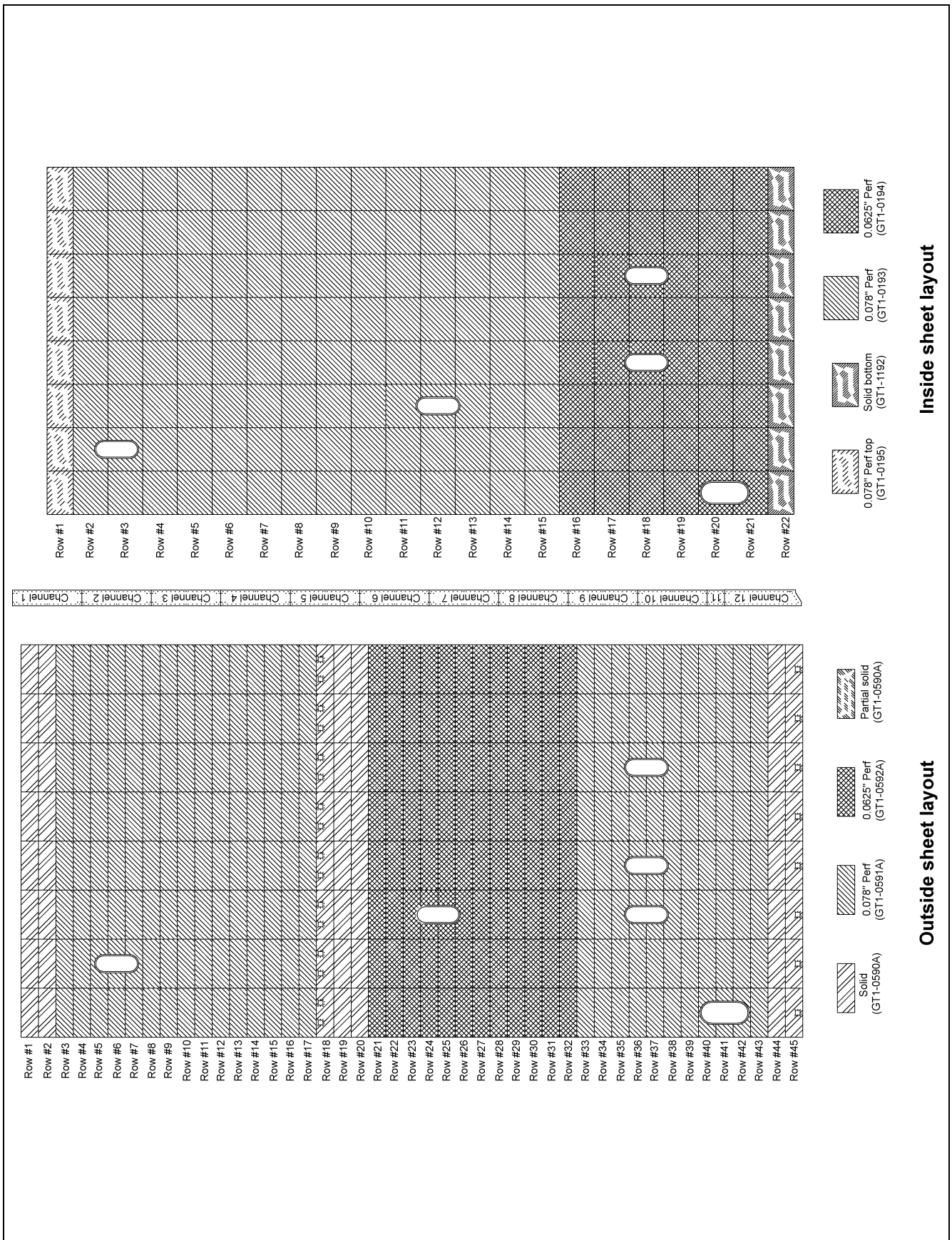

Figure 26GB Z-2420/R3124/24100 Sheet Layout

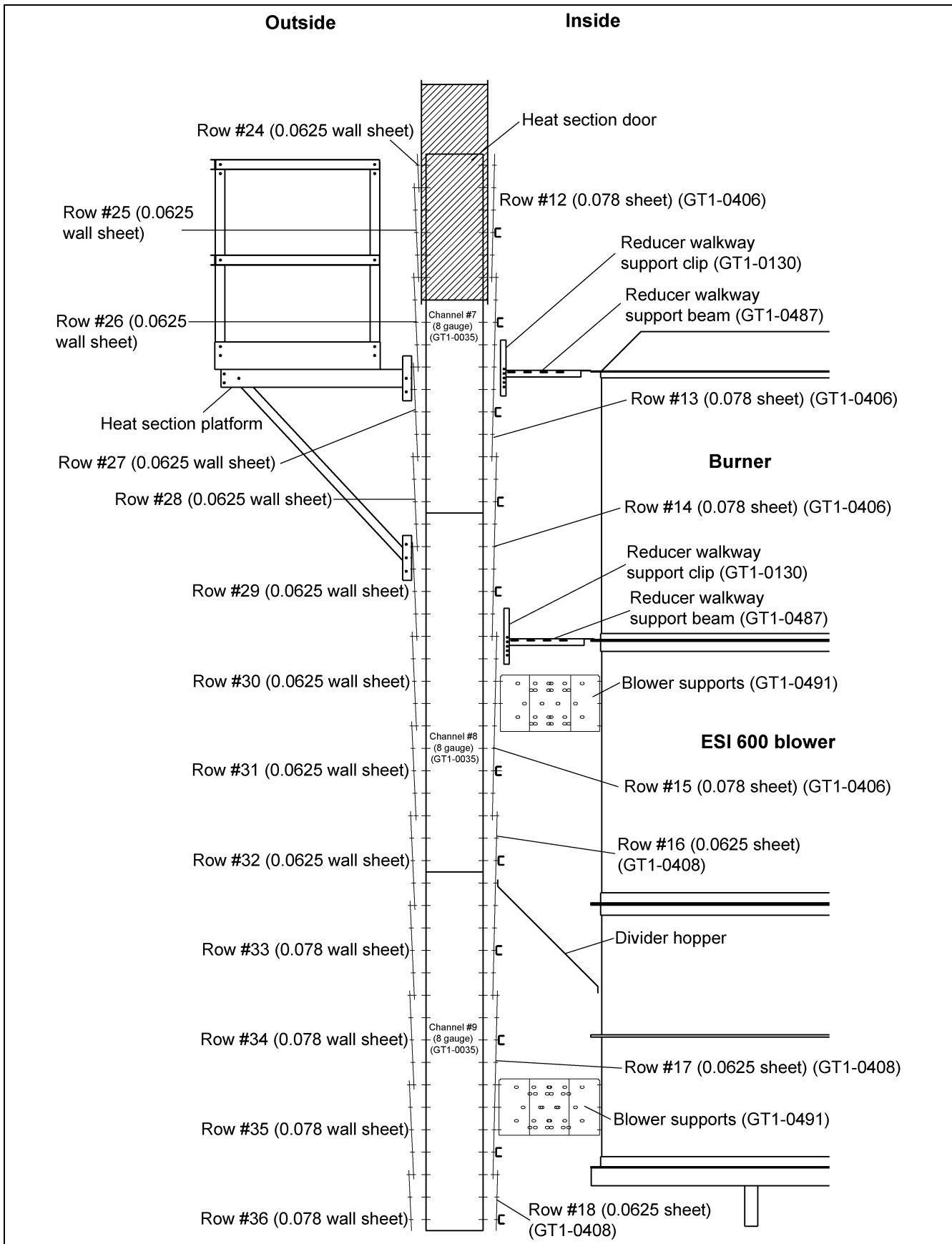

Figure 26GC Clip Placement Z-2420 Channels 7 to 9

26. All Tower Dryer Models Drawings

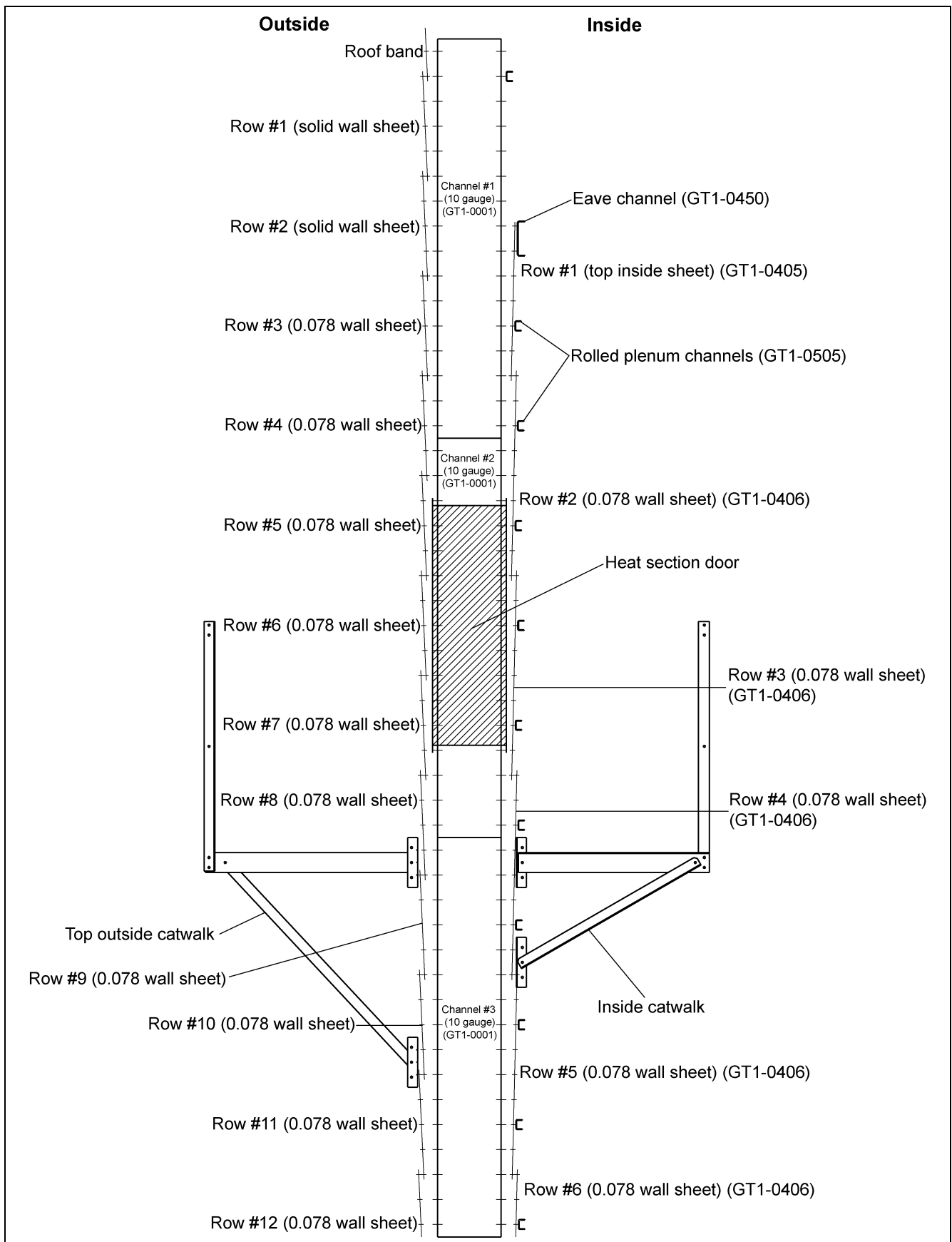

Figure 26GD Clip Placement Z-2420 Channels 1 to 3

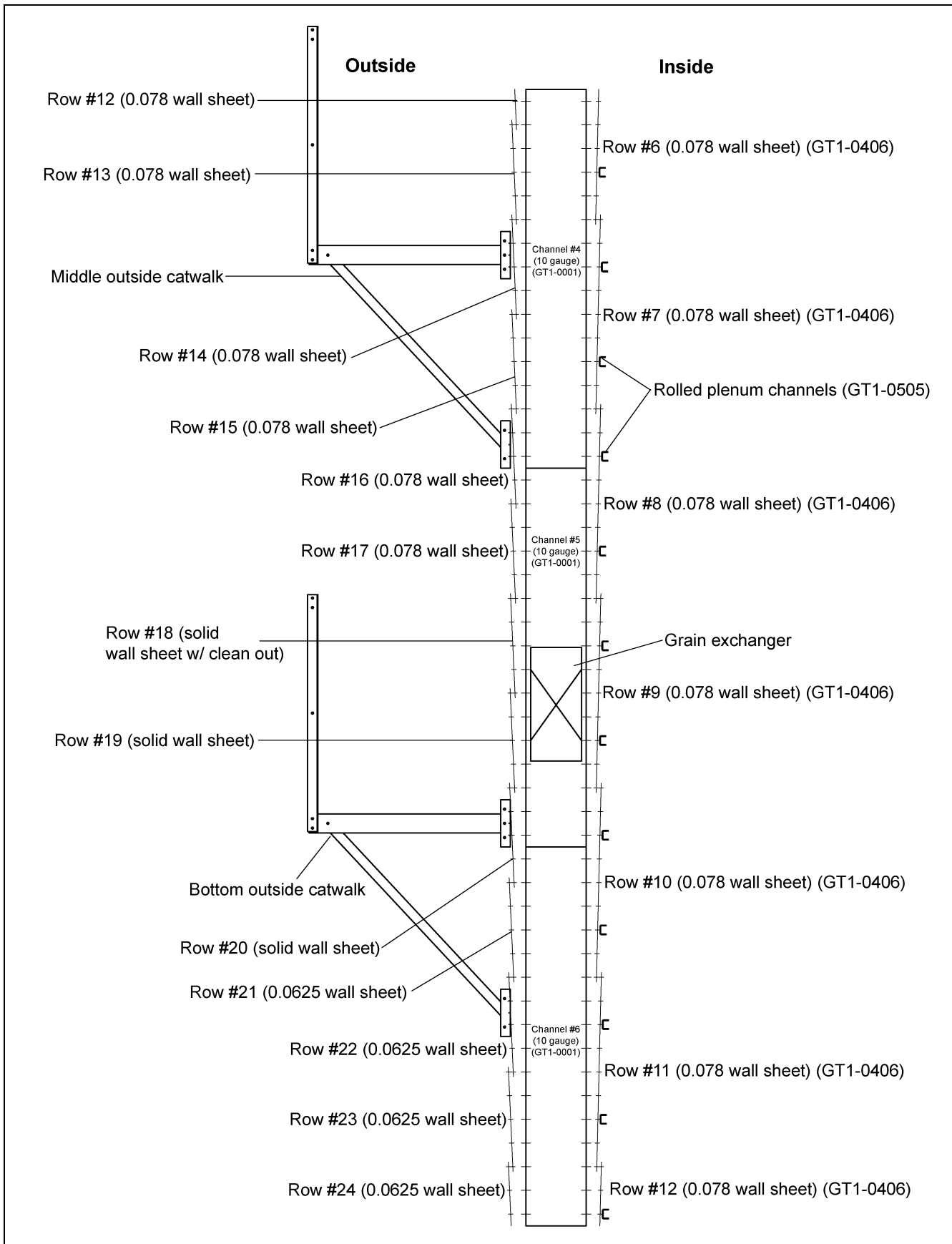

Figure 26GE Clip Placement Z-2420 Channels 4 to 6

26. All Tower Dryer Models Drawings

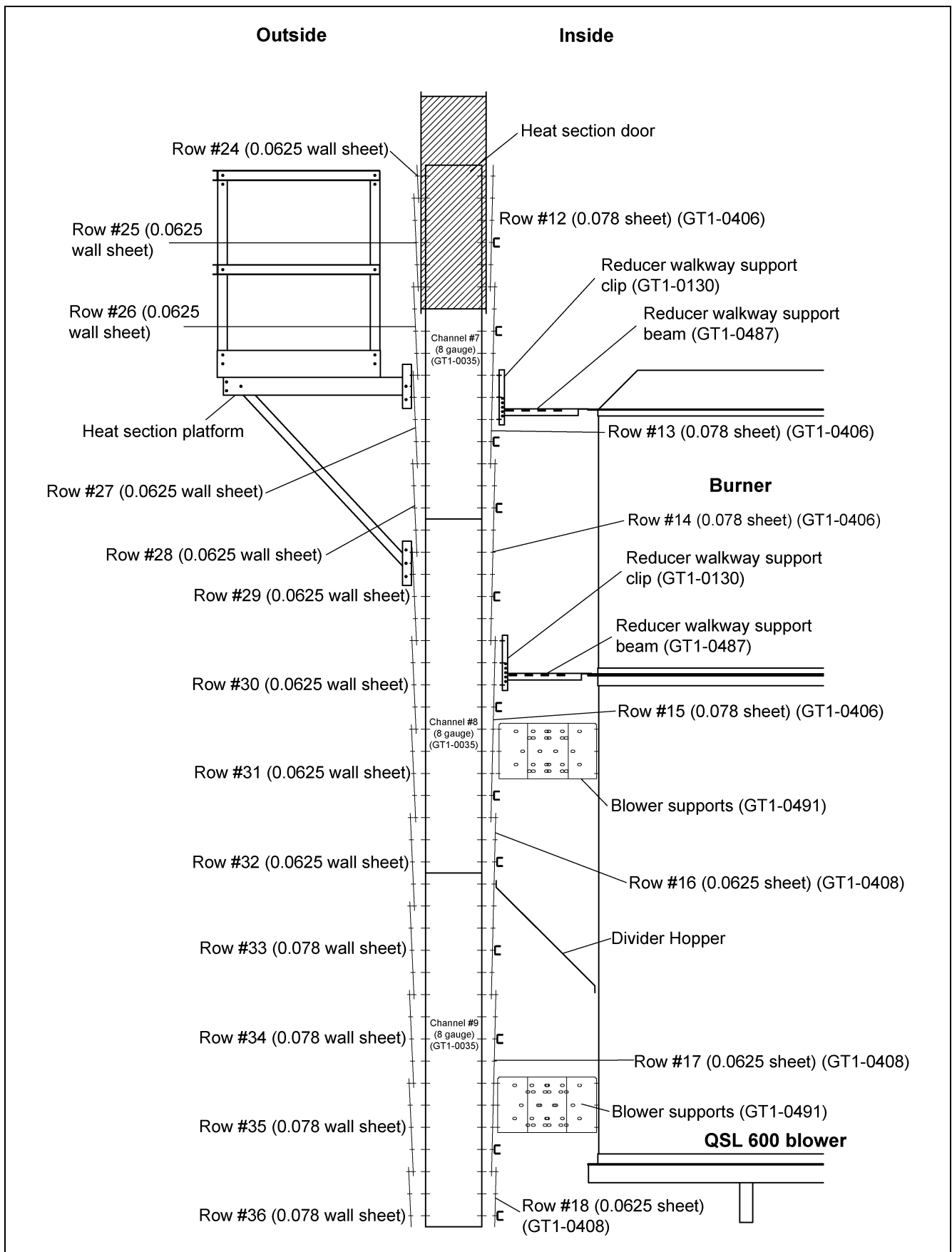

Figure 26GF Clip Placement Z-2420 w/ QSL Blower Channels 7 to 9

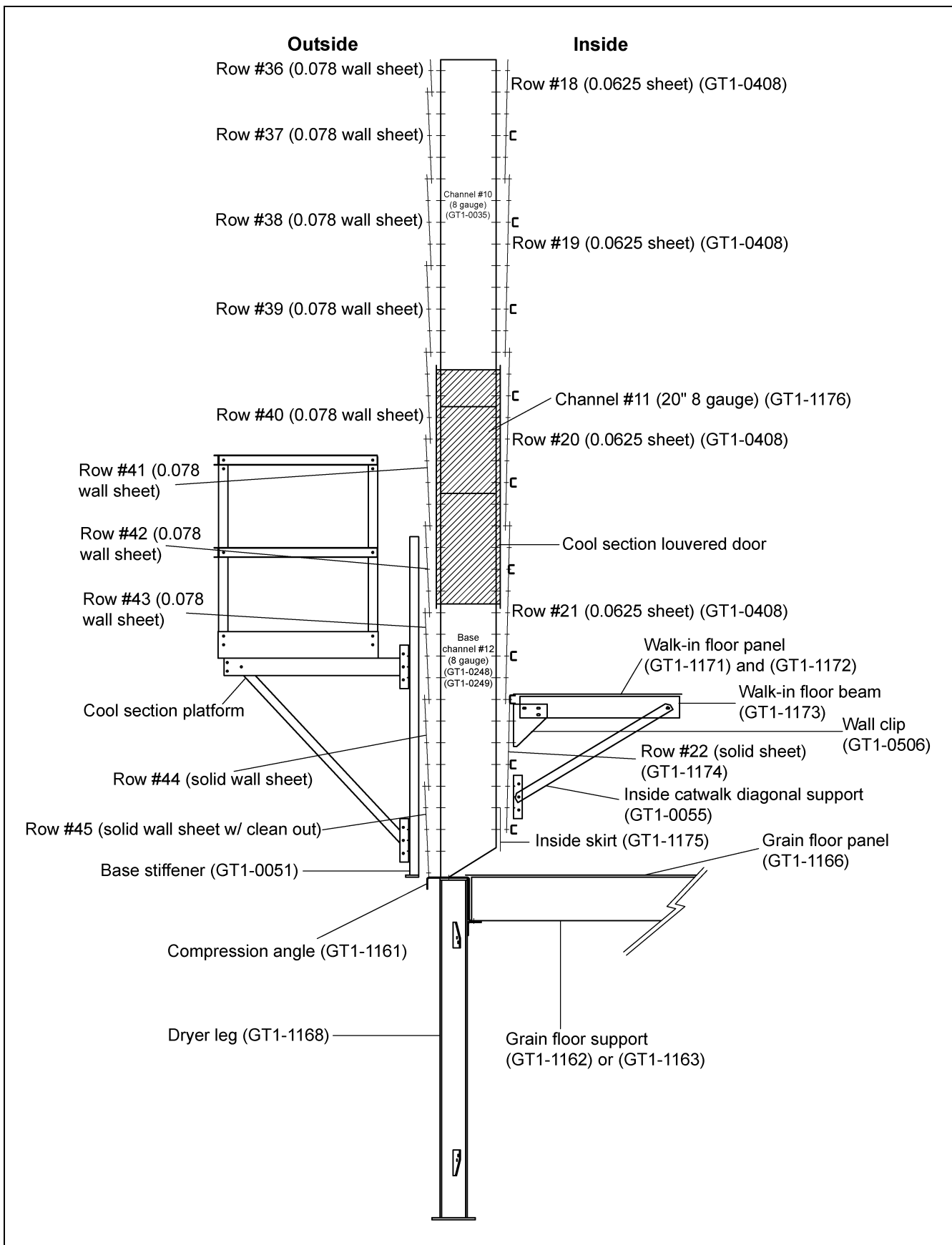

Figure 26GG Clip Placement Z-2420 Channels 10 to 12

26. All Tower Dryer Models Drawings

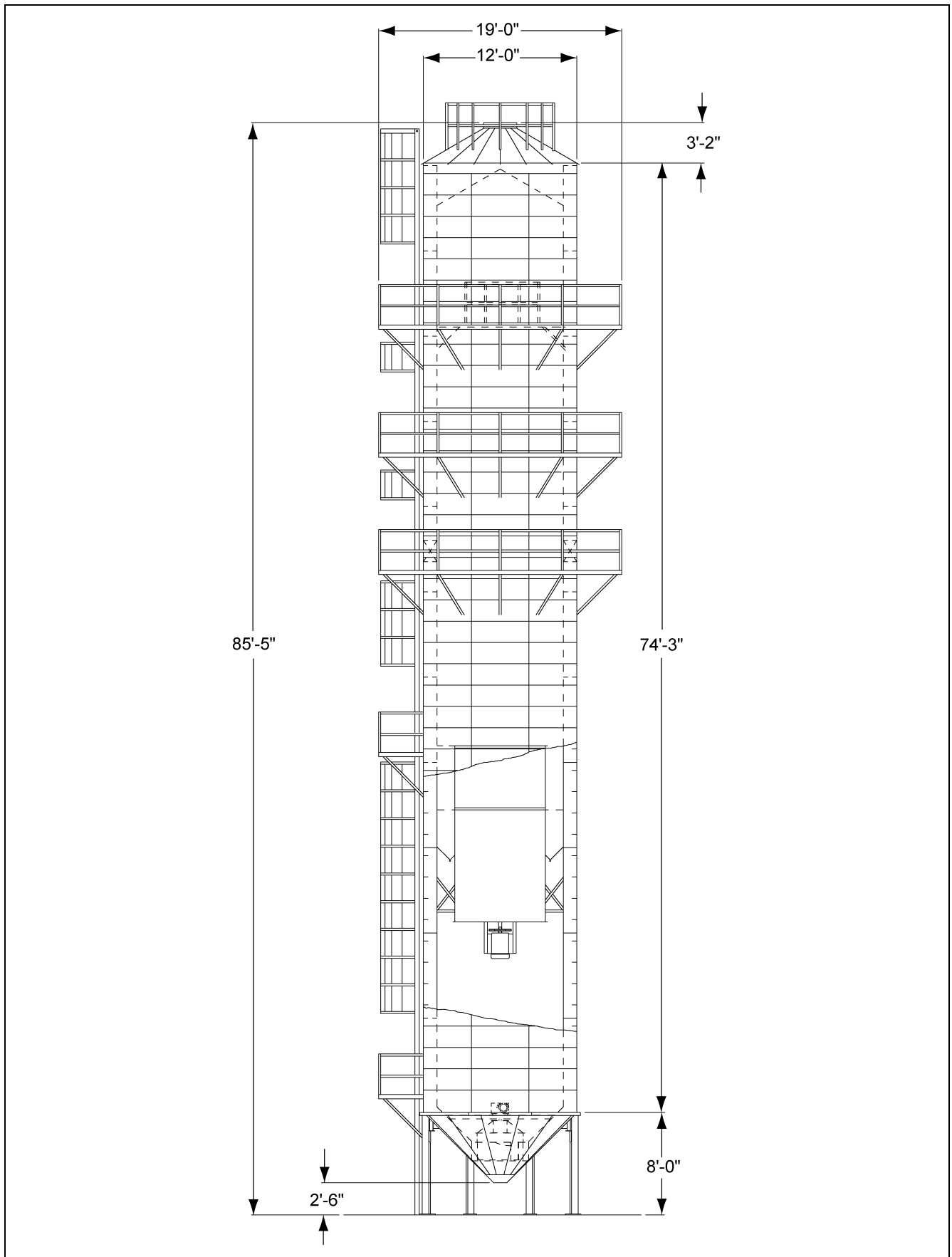

Figure 26GH Zimmerman Tower Dryer Model Z-2420

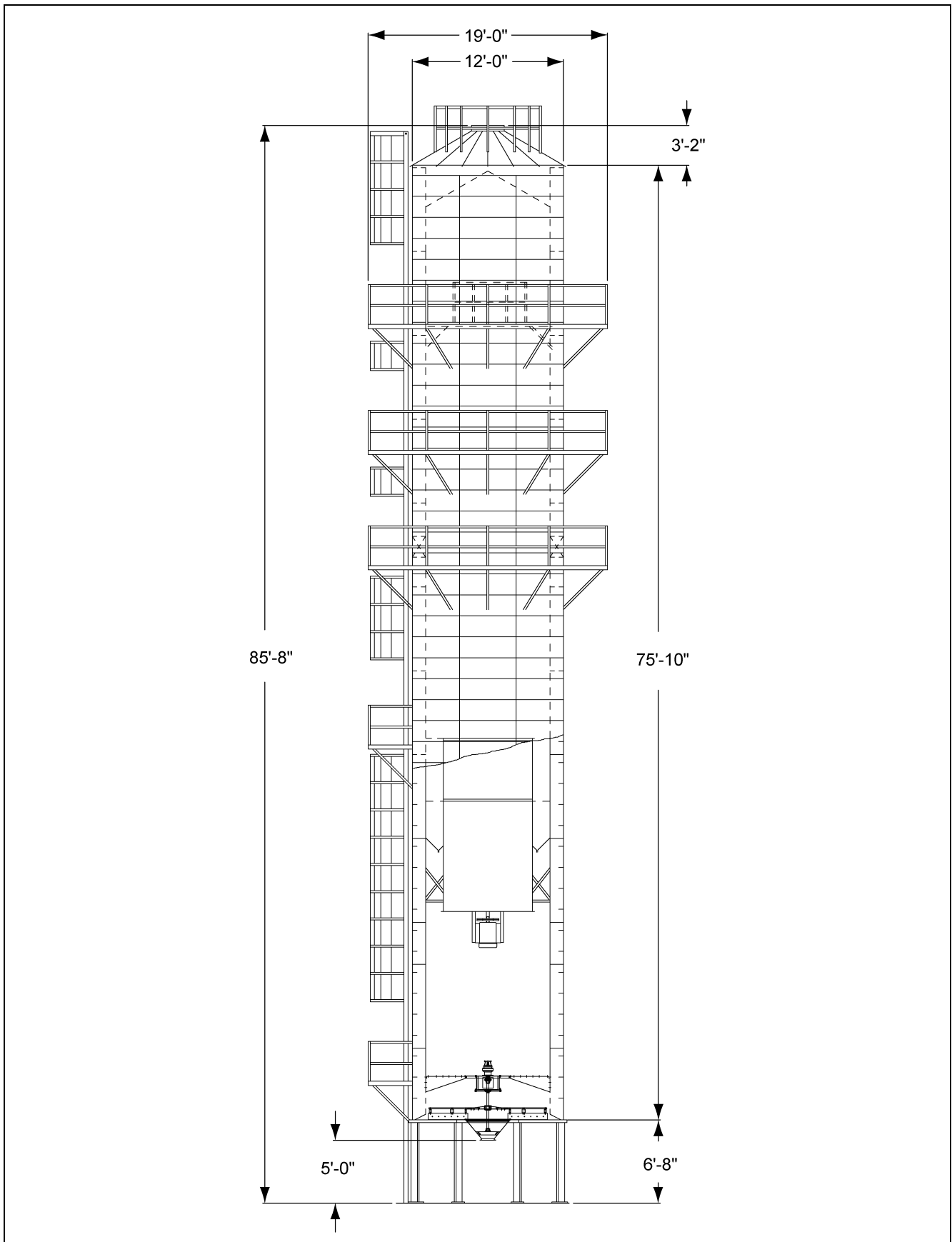

Figure 26G1 GSI Tower Dryer Model 2400

26. All Tower Dryer Models Drawings

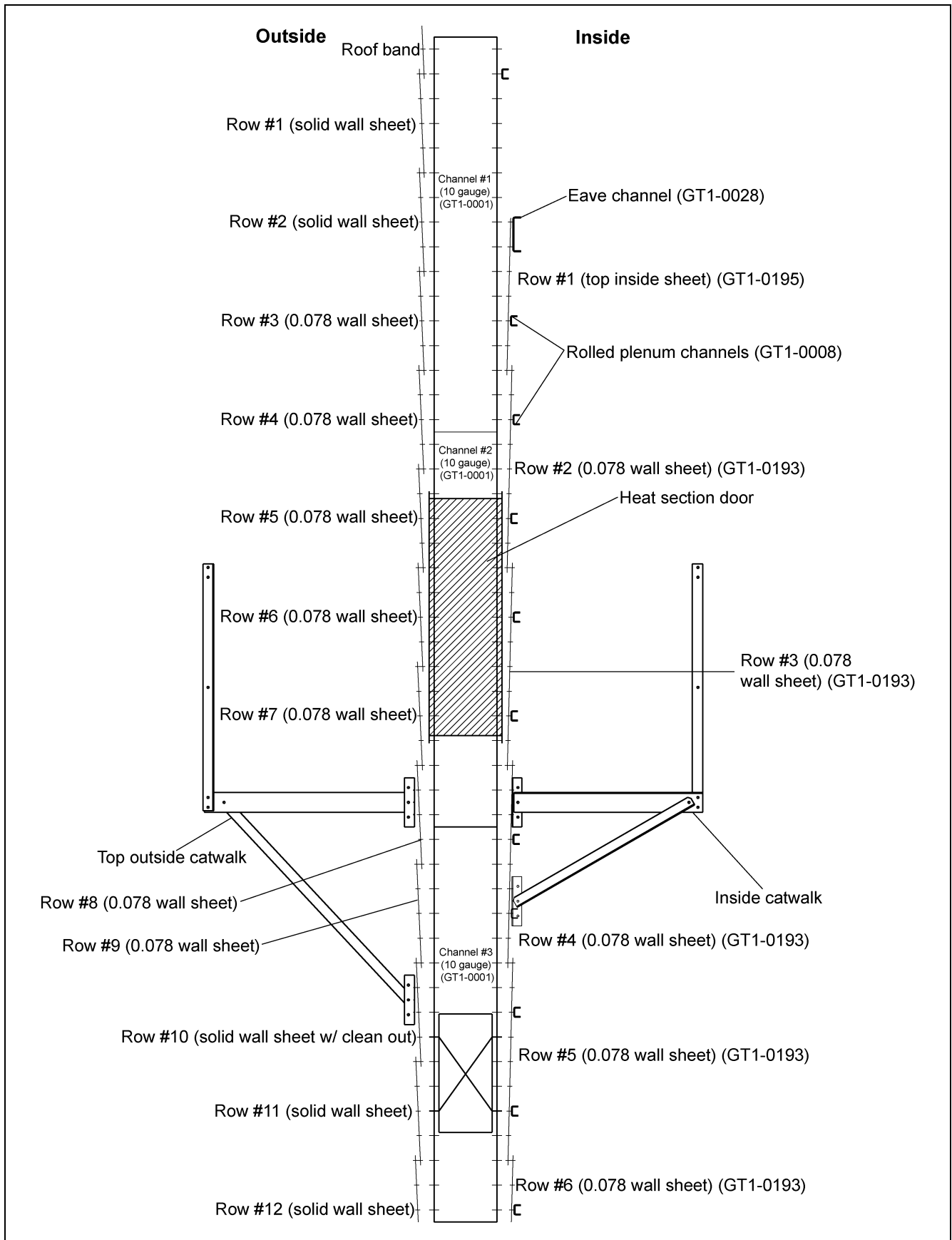

Figure 26GJ Clip Placement G-2500 Channels 1 to 3

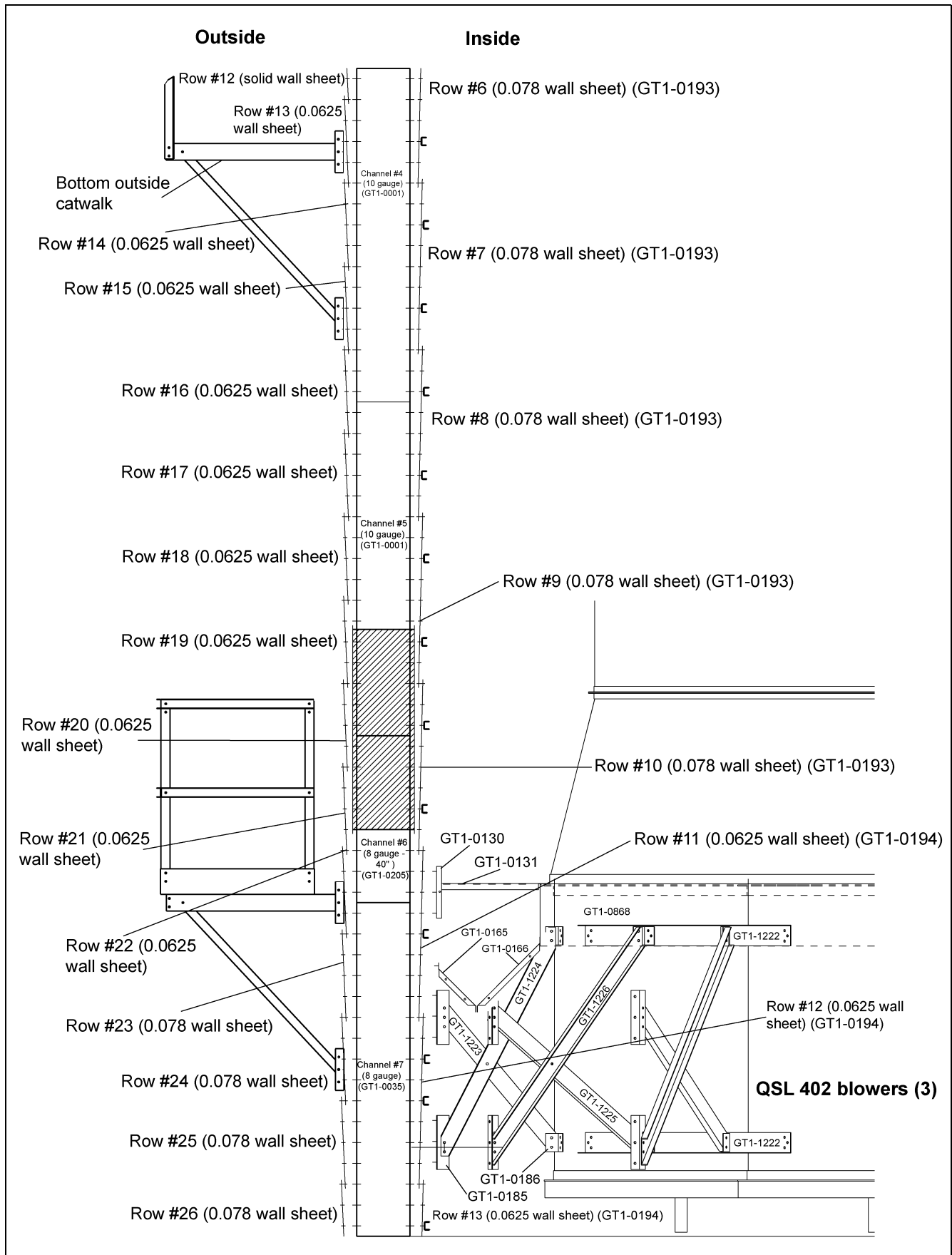

Figure 26GK Clip Placement G-2500 QSL Blower Channels 4 to 7

26. All Tower Dryer Models Drawings

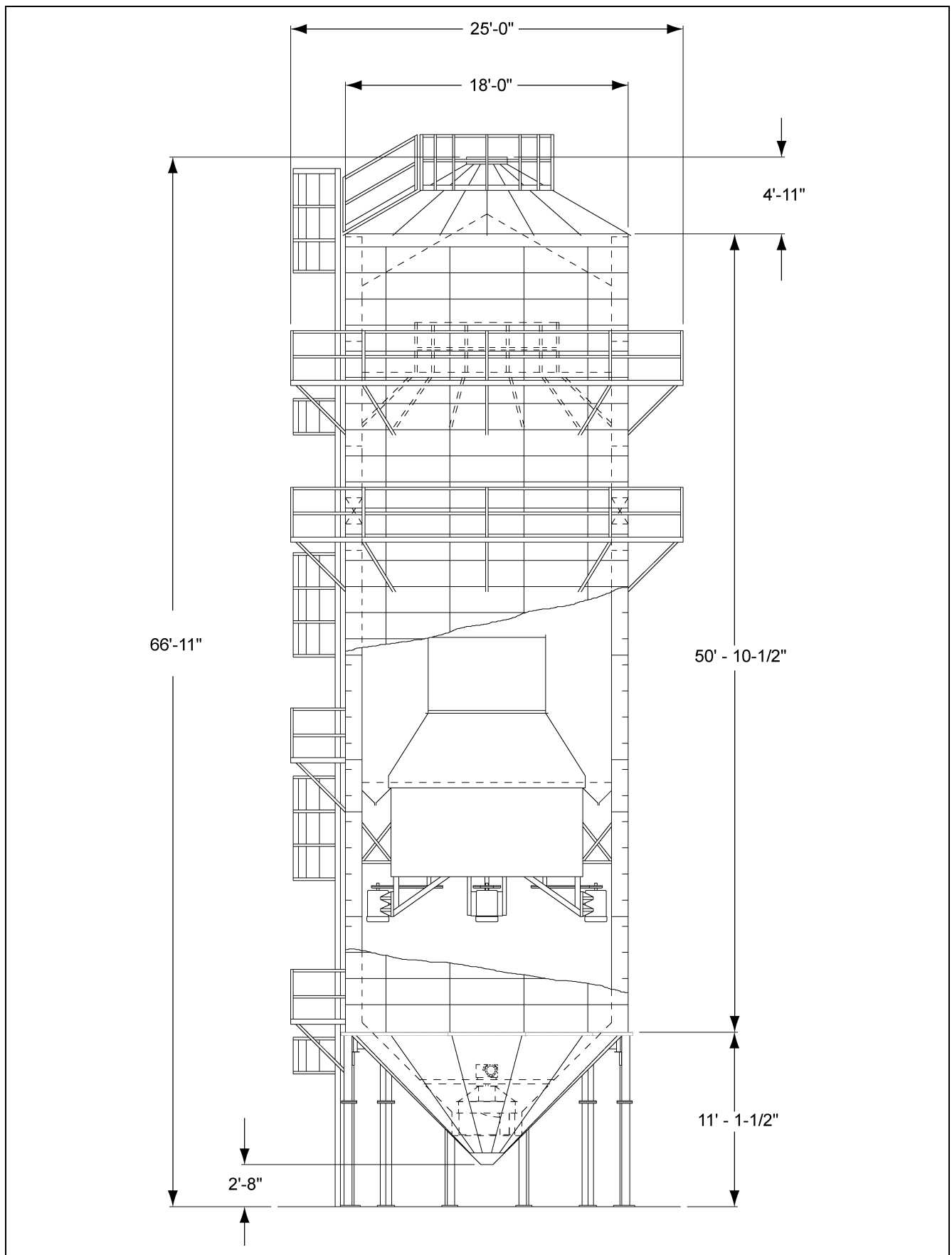

Figure 26GL GSI Tower Dryer Model 2500

Tools and Equipment

IMPORTANT: *Dryer parts have sharp edges. Use appropriate personal protective equipment. Use proper lifting technique.*

Eight (8) jacks (10000 pound, 14' lift), and lifting tackle.

- Forklift(s), hoist, or tractor with 2" x 14' nylon lifting straps, rating 2000 pounds. (Optional to place electrical control system).
- Dollies (with 5/8" x 2" heavy structural bolts to secure load). (Motor and blower types.)
- 3/8" and 1/2" Drive impact wrench or ratchet, with sockets.
- Drill: 1/2" (1.27 cm), 3/8" (0.9525 cm) Bits, and assorted drill bits.
Hammer Drill: 1/2" (1.27 cm) Masonry bits.
7/8" (2.2225 cm) Masonry bit.
- Wrenches: 1/2" (1.27 cm), 7/16" (1.11125 cm), 9/16" (1.42875 cm), 5/8" (1.5875 cm), 11/16" (1.74625 cm), 3/4" (1.905 cm), 15/16" (2.016125 cm)
Hex wrenches (allen wrenches): 1/8" (0.3175 cm), 5/32" (0.396875), 3/16" (0.47625 cm), 3/8" (0.9525 cm).
- Tongue and groove pliers, locking pliers (vise grips).
- Banding cutters or equivalent equipment.
- Reciprocating saw or hacksaw.
- 3/8" x 12" and larger alignment punches, C-clamps.
- Electrical extension cords, 12 gauge heavy duty, weather-tight.
- Hammers, 10 pound, 2 pound, 13 ounce ball-peen.
- Stepladders (4', 8'), extension ladder.
- 12" level, level-transit, tape measure.
- Heavy-duty pipe sealing compound.
- Marking pen (for steel, concrete).
- Injection silicone caulking, clean-out brush, and air bulb.
- WD40 machine weight lubricating oil.
- Touch-up paint.

Tools and Equipment (Continued)



Figure 27A C-Clamp and assorted alignment punches.

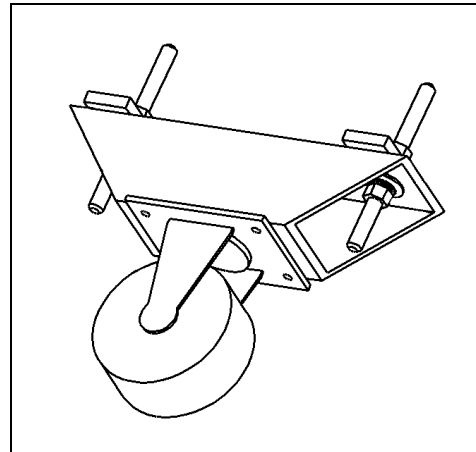

Figure 27D Dolly is a low, flat, wheeled frame used to move heavy parts, for example, fans.



Figure 27B Metal shear to cut wall sheets and screen.



Figure 27E Level-Transit



Figure 27C Drill with ball-hone to clean out gearbox bore.

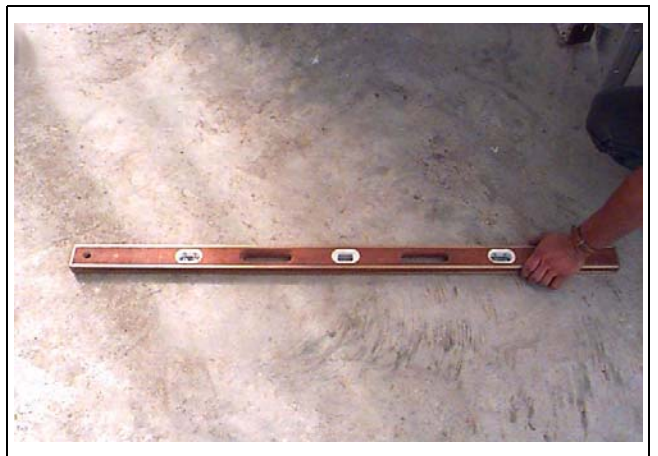

Figure 27F Level

Hardware

Quantity of hardware varies by dryer model.

Description

Uses

Galvanized

5/16" (0.79375 cm) x 3/4" (1.905 cm) Slotted Truss Head Bolt	Cool Room Floor
5/16" (0.79375 cm) x 3/4" (1.905 cm) Whiz Lock Bolt	Inside Wall Sheets
5/16" (0.79375 cm) x 1" (2.54 cm) Whiz Lock Bolt	Inside Wall Sheets
5/16" (0.79375 cm) Whiz Lock Nut	Inside Wall Sheets
#10 x 1" (2.54 cm) Self Tapping Screw.....	Heat Section Door and Cool Room Floor
3/8" (0.9525 cm) Washer	Walkways
3/8" (0.9525 cm) Hex Head Nut	Walkways
3/8" (0.9525 cm) x 1" (2.54 cm) Hex Head Bolt	Walkways
3/8" (0.9525 cm) x 2" (5.08 cm) Hex Head Bolt	Lifting Clips to Vertical Channels and Base Stiffeners to Vertical Channels
1/2" (1.27 cm) x 1" (2.54 cm) Hex Head Bolt	Outside Hopper Sheets and Gearbox Motor to Gearbox
1/2" (1.27 cm) Hex Head Nut	Outside Hopper Sheets
1/2" (1.27 cm) Washer	Outside Hopper Sheets
1/2" (1.27 cm) x 1-1/2" Grade 8, Hex Head Bolt	Blower Bracing
1/2" (1.27 cm) x 2-1/2" Grade 5, Hex Head Bolt	Base Stiffeners
5/8" (1.5875 cm) x 1-1/2" Grade 8, Hex Head Bolt	Legs
5/8" (1.5875 cm) x 2-3/4" Grade 8, Hex Head Bolt	Base Stiffeners to Legs
5/8" (1.5875 cm) x 2" (5.08 cm) Grade 8, Hex Head Bolt	Leg to Leg
5/8" (1.5875 cm), Grade 5-1, Hex Head Nut.....	Leg to Leg
3/4" (1.905 cm) Washer (1-1/2" diameter)	Legs
3/4" (1.905 cm) Hex Head Nut.....	X-Rods
3/4" (1.905 cm) Washer (2" diameter)	X-Rods

Stainless Steel

5/16" (0.79375 cm) x 3/4" (1.905 cm) Whiz Lock Bolt	Outside Wall Sheets
5/16" (0.79375 cm) x 1" (2.54 cm) Whiz Lock Bolt	Outside Wall Sheets
5/16" (0.79375 cm) Whiz Lock Nut	Outside Wall Sheets

Miscellaneous

Anchor Bolt, HILTI HAS, 3/4" (1.905 cm) x 9-5/8"	Legs
Anchor Bolt, Heavy Duty Expanding, 1/2" (1.27 cm) x 3-3/4"	Control Box
De Sta Co Clamp	Hopper Access Port

Hardware (Continued)

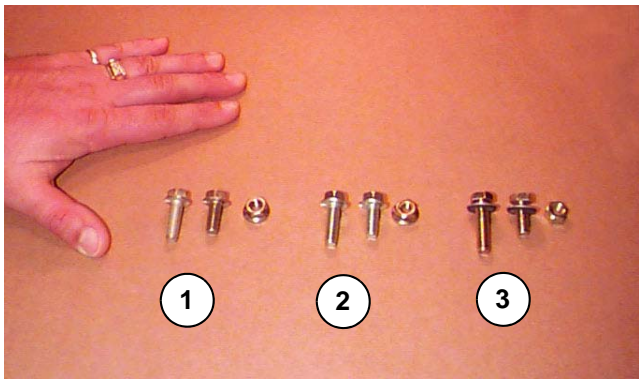

- 1. Stainless, Whiz Lock
 - Bolts = Dull silver
 - Nuts = Shiny silver (with flange)
- 2. Galvanized, Whiz Lock
 - Bolts = Shiny silver
 - Nuts = Yellow (with flange)
- 3. Bin, Hex Head
 - Bolts = Yellow (with neoprene washers)
 - Nuts = Yellow (no flange)

Figure 28A Comparison of 5/16" Hardware



Figure 28B Anchor bolt, HILTI HAS, 3/4" x 9-5/8"



Figure 28C Anchor bolt, heavy duty expanding, 5-1/2"



Figure 28D De Sta Co Clamp

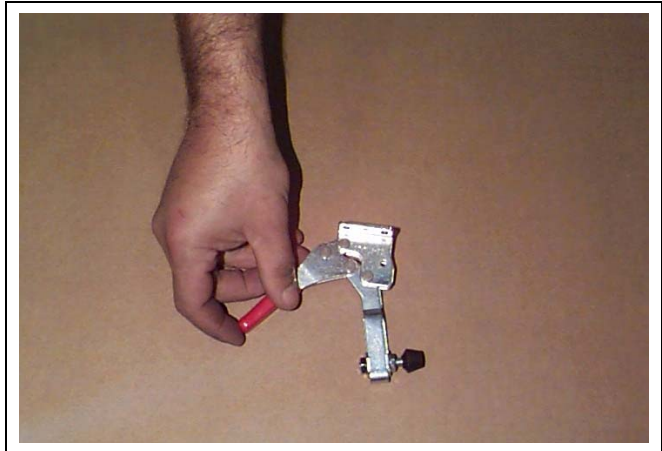

Figure 28E De Sta Co Clamp - Assembled

Hardware - Galvanized

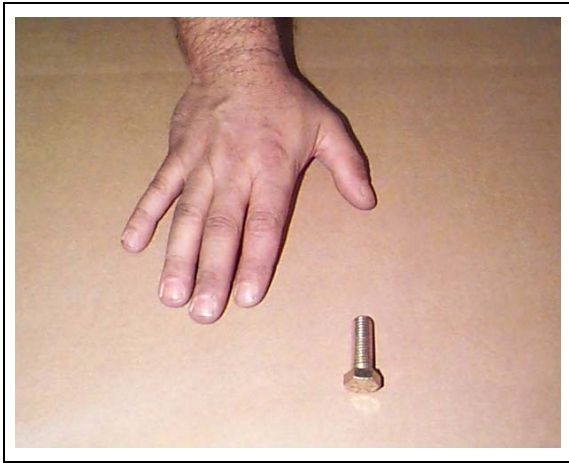

Figure 28F *1/2" x 1-1/2" Grade 8 Hex Head Bolt*

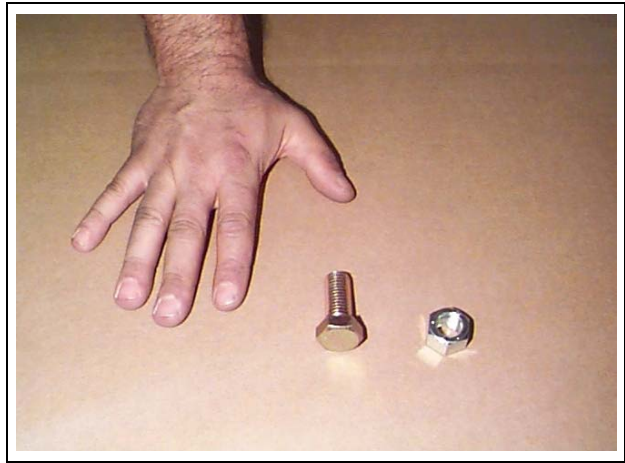

Figure 28I *5/8" x 1-1/2" Grade 8 Hex Head Bolt*

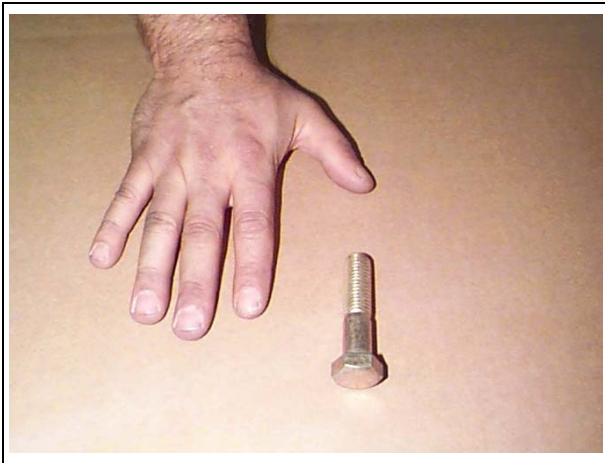

Figure 28G *1/2" x 2-1/2" Hex Head Bolt*

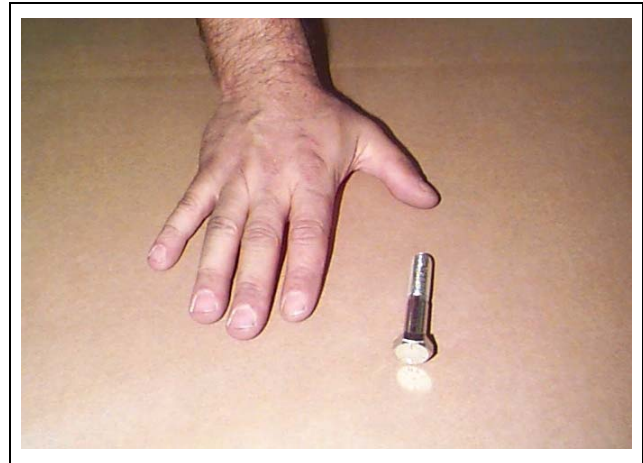

Figure 28J *5/8" x 2-3/4" Hex Head Bolt*



Figure 28H *1/2" x 1" Hex Head Bolt, Washer and Nut*



Figure 28K *3/4" (2" Diameter) Washer*

Hardware - Galvanized (Continued)

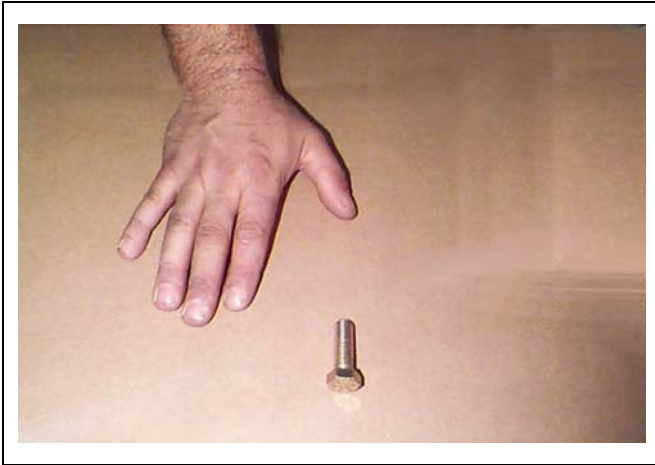

Figure 28L *3/8" x 1" Hex Head Bolt*

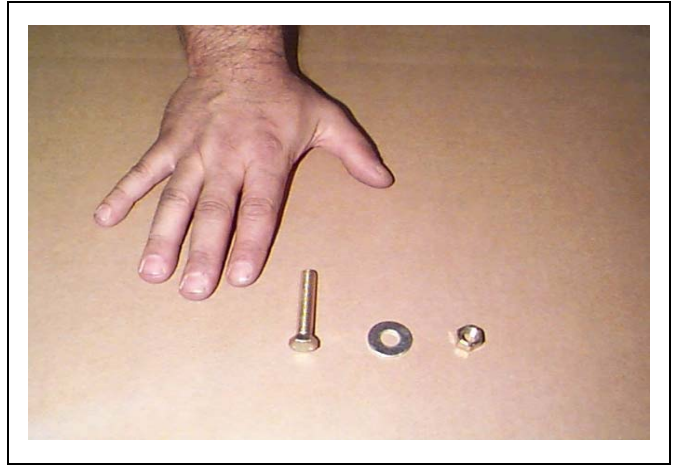

Figure 28N *3/8" x 2" Bolt, Washer and Nut*

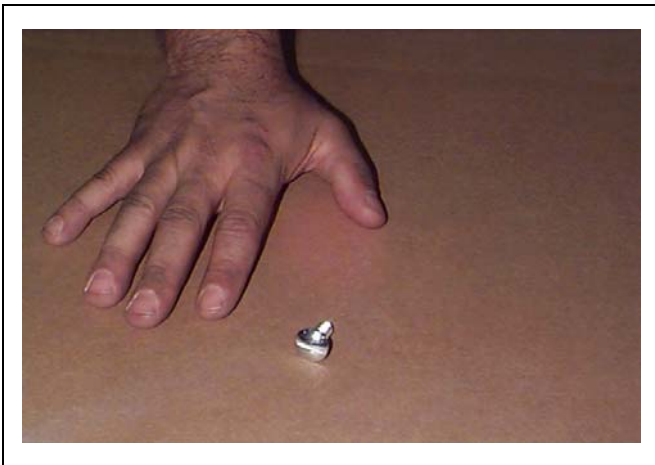

Figure 28M *5/16" x 3/4" Slotted Truss Head Bolt*

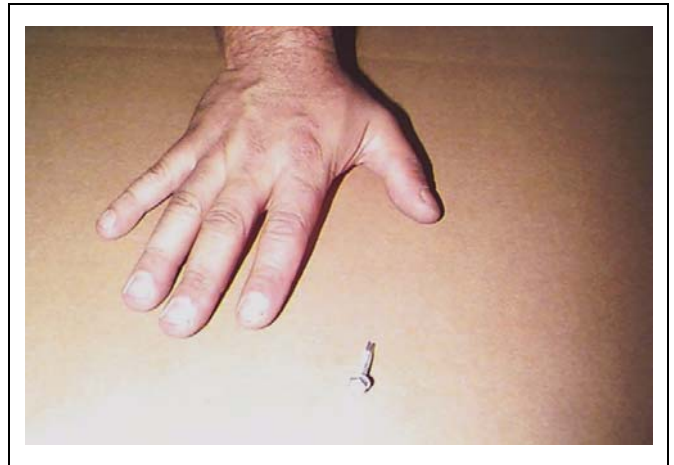

Figure 28O *#10 x 1" Self Tapping Screw*

Assembly Terms

Terms	Meaning
Assembly of parts.....	Parts are fit together, and often bolted.
Bindicator(s) [®]	<p><u>Lower bindicator</u> is installed high on the side of all dryers. It indicates low grain level in garner section, and automatically starts flow of grain to dryer.</p> <p><u>Upper bindicator</u> is only installed on slide gate or conveyor fill dryers (on roof). It indicates when garner section is full, and automatically stops flow of grain to dryer.</p>
Bolt.....	Tightly bolt for final assembly unless otherwise indicated.
	Loosely bolt..... Bolt loosely to allow easy addition of parts later.
	Snug bolt..... Tighten bolt snug with fingers to hold in place.
	Common bolt..... Insert bolt through all parts to be held together.
	Existing bolts..... Refers to bolts already installed in dryer.
BPH.....	Bushels per hour.
Channel.....	Metal part whose channel is shaped like a bracket]. Examples: Vertical channels, rolled plenum channels.
Double nut.....	Spin two (2) nuts closely together on bolt. Tighten second nut against first nut to lock.
Fines.....	Fine debris from grain. Also called bee's wings. Avoid hazardous accumulation of fines in dryer.
Flange.....	A projecting rim or edge on a part to hold it to another part.
Grain columns.....	The space around dryer through which grain flows from top to bottom. Each grain column is formed by columns of vertical channels, inside wall sheets, outside wall sheets.
Grain turner.....	Turns dryer-warmed grain from inside grain column to outside of grain column, and turns wetter, cooler grain from outside of grain column to inside of grain column. Grain dries uniformly.
Hoppers.....	<p>Divider hopper - Divides heat section from cool section. - Funnels fine debris to cooling section.</p> <p>Discharge hopper - Located below cool section floor. - Directs grain to metering drum for discharge.</p>
Level.....	Even across, horizontal.
L.H.....	Left hand.
Lift.....	Raise dryer to clear next set of vertical channels.
Motor window.....	Dryer fan motors conduits enter through the motor window.

Assembly Terms (Continued)

Terms	Meaning
Overheats.....	Detect air temperature that has exceeded a preset limit.
Overlap.....	Lap. Each part extends over previous part, usually bolted together with common bolts.
Pipe sealing compound.....	Also called heavy-duty thread sealing compound, or pipe dope.
Plenum.....	Hot, dry air chamber above burner in dryer.
Plumb.....	Straight down, vertical.
R.H.....	Right hand.
RTD.....	Resistance Temperature Device. RTD measures temperature of grain/air.
Wall sheets.....	Dryer walls (inside and outside) are build with rings of wall sheets. Also called screens. Sizes are 0.063 perforated sheet and 0.078 perforated sheet.

U.S. to Metric Conversion Tables

Refer to the conversion tables in Appendix E for conversions from U.S. measures to metric measurements.

To assemble this grain dryer, you may need standard U.S. dimension tools. However, some metric tools will fit on U.S. dimension hardware.

Inch Conversion Table

Fractions	Decimals	Millimeters
1/64	0.0156	0.3969
1/32	0.0313	0.07938
3/64	0.0469	1.1906
1/16	0.0625	1.5875
5/64	0.0781	1.9844
3/32	0.0938	2.3813
7/64	0.1094	2.7781
1/8	0.125	3.1750
9/64	0.1406	3.5719
5/32	0.1563	3.9688
11/64	0.1719	4.3656
3/16	1.875	4.7625
13/64	0.2031	5.1594
7/32	0.2188	5.5563
15/64	0.2344	5.9531
1/4	0.250	6.3500
17/64	0.2656	6.7469
9/32	0.2813	7.1438
19/64	0.2969	7.5406
5/16	0.3125	7.9375
21/64	0.3281	8.3344
11/32	0.3438	8.7313
23/64	0.3594	9.1281
3/8	0.375	9.5250
25/64	0.3906	9.9219
13/32	0.4063	10.3188
27/64	0.4219	10.7156
7/16	0.4375	11.1125
29/64	0.4531	11.5094
15/32	0.4688	11.9063
31/64	0.4844	12.3031
1/2	0.500	12.7000

Fractions	Decimals	Millimeters
33/64	0.5156	13.0969
17/32	0.5313	13.4938
35/64	0.5469	13.8906
9/16	0.5625	14.2875
37/64	0.5781	14.6844
19/32	0.5938	15.0813
39/64	0.6094	15.4781
5/8	0.625	15.8750
41/64	0.6406	16.2719
21/32	0.6563	16.6688
43/64	0.6719	17.0656
11/16	0.6875	17.4625
45/64	0.7031	17.8594
23/32	0.7188	18.2563
47/64	0.7344	18.6531
3/4	0.750	19.0500
49/64	0.7656	19.4469
25/32	0.7813	19.8438
51/64	0.7969	20.2406
13/16	0.8125	20.6375
53/64	0.8281	21.0344
27/32	0.8438	21.4313
55/64	0.8594	21.8281
7/8	0.875	22.2250
57/64	0.8906	22.6219
29/32	0.9063	23.0188
59/64	0.9219	23.4156
15/16	0.9375	23.8125
61/64	0.9531	24.2094
31/32	0.9688	24.6063
63/64	0.9844	25.0031
1	1.000	25.4000

U.S. to Metric Conversion Tables (Continued)

Conversion Factors

Multiply	By	To Obtain
British Thermal Unit (Btu)	2.928×10^{-4}	Kilowatt · Hr (kWh)
Btu/Hr	3.930×10^{-4}	Horsepower (HP)
Btu/Hr	0.293	Watt (W)
Horsepower (HP)	745.7	Watt (W)
Inch (in.)	2.540	Centimeter (cm)
Foot (ft.)	0.3048	Meter (m)
Pound-mass (lbm avdp*)	0.454	Kilogram (kg)
Pounds Per Square Inch (PSI)	6,895	Pascal (Pa)
Bushels (BU)	0.03524	Cubic Meter (m ³)
°F (Fahrenheit)	$(F^{\circ} - 32) / 1.8$	°C (Celsius)
°C (Celsius)	$1.8 (C^{\circ}) + 32$	°F (Fahrenheit)

*avdp = avoirdupois

AWG* Wire Gauge (solid conductor wire)

AWG Gauge #	Cross-sectional Area		Diameter of Solid Wire	Circular
	mm ²	inches ²	mm	mils
32	0.0032	0.00005	0.0202	63.2
30	0.0505	0.000079	0.255	100.5
28	0.0806	0.000125	0.321	159.8
26	0.129	0.000199	0.405	254
	0.196	0.000304	0.5	387
24	0.205	0.000317	0.511	404
	0.283	0.00483	0.6	558
20	0.518	0.000802	0.812	1022
	0.75	0.001162	0.977	1480
18	0.821	0.001272	1.022	1620
	1	0.00155	1.128	1973
16	1.307	0.002026	1.29	2580
	1.5	0.002325	1.382	2960
14	2.082	0.003228	1.628	4110
	2.5	0.003875	1.784	4934
12	3.309	0.005129	2.053	6530
	4	0.0062	2.257	7894
10	5.26	0.008152	2.588	10380
	6	0.0093	2.763	11841
8	8.365	0.012967	3.264	16540
	10	0.0155	3.568	19735
6	13.296	0.02061	-	26240
	16	0.0248	-	31576
4	21.15	0.03278	-	41740
	25	0.0388	-	49338
2	33.62	0.0521	-	66360

*American wire gauge.

Limited Warranty — N.A. Grain Products

The GSI Group, LLC. (“GSI”) warrants products which it manufactures, to be free of defects in materials and workmanship under normal usage and conditions for a period of 12 months from the date of shipment (or, if shipped by vessel, 14 months from the date of arrival at the port of discharge). If, in GSI’s sole judgment, a product is found to have a defect in materials and/or workmanship, GSI will, at its own option and expense, repair or replace the product or refund the purchase price. This Limited Warranty is subject to extension and other terms as set forth below.

Warranty Enhancements: The warranty period for the following products is enhanced as shown below and is in lieu of (and not in addition to) the above stated warranty period. (Warranty Period is from date of shipment.)

	Product	Warranty Period
Storage	Grain Bin Structural Design • Sidewall, roof, doors, platforms and walkarounds • Flooring (when installed using GSI specified floor support system for that floor) • Hopper tanks (BFT, GHT, NCHT, and FCHT)	5 Years
Conditioning	Dryer Structural Design – (Tower, Portable and TopDry) • Includes (frame, portable dryer screens, ladders, access doors and platforms)	5 Years
	All other Dryer parts including: • Electrical (controls, sensors, switches and internal wiring)	2 Years
	All Non-PTO Driven Centrifugal and Axial Fans	3 Years
	Bullseye Controllers	2 Years
Material Handling	Bucket Elevators Structural Design	5 Years
	Towers Structural Design	5 Years
	Catwalks Structural Design	5 Years
	Accessories (stairs, ladders and platforms) Structural Design	5 Years

Conditions and Limitations:

THERE ARE NO WARRANTIES THAT EXTEND BEYOND THE LIMITED WARRANTY DESCRIPTION SET FORTH HEREIN; SPECIFICALLY, GSI DISCLAIMS ANY AND ALL OTHER WARRANTIES OF ANY KIND, EXPRESS OR IMPLIED, INCLUDING, WITHOUT LIMITATION, WARRANTIES OF MERCHANTABILITY OR FITNESS FOR A PARTICULAR PURPOSE OR USE IN CONNECTION WITH: (I) ANY PRODUCT MANUFACTURED OR SOLD BY GSI, OR (II) ANY ADVICE, INSTRUCTION, RECOMMENDATION OR SUGGESTION PROVIDED BY AN AGENT, REPRESENTATIVE OR EMPLOYEE OF GSI REGARDING OR RELATED TO THE CONFIGURATION, INSTALLATION, LAYOUT, SUITABILITY FOR A PARTICULAR PURPOSE, OR DESIGN OF SUCH PRODUCTS.

The sole and exclusive remedy for any claimant is set forth in this Limited Warranty and shall not exceed the amount paid for the product purchased. This Warranty only covers the value of the warranted parts and equipment, and does not cover labor charges for removing or installing defective parts, shipping charges with respect to such parts, any applicable sales or other taxes, or any other charges or expenses not specified in this Warranty. GSI shall not be liable for any other direct, indirect, incidental or consequential damages, including, without limitation, loss of anticipated profits or benefits. Expenses incurred by or on behalf of a claimant without prior written authorization from the GSI warranty department shall not be reimbursed. This warranty is not transferable and applies only to the original end-user. GSI shall have no obligation or responsibility for any representations or warranties made by or on behalf of any dealer, agent or distributor. Prior to installation, the end-user bears all responsibility to comply with federal, state and local codes which apply to the location and installation of the products.

This Limited Warranty extends solely to products sold by GSI and does not cover any parts, components or materials used in conjunction with the product, that are not sold by GSI. GSI assumes no responsibility for claims resulting from construction defects, unauthorized modifications, corrosion or other cosmetic issues caused by storage, application or environmental conditions. Modifications to products not specifically delineated in the manual accompanying the product at initial sale will void all warranties. This Limited Warranty shall not extend to products or parts which have been damaged by negligent use, misuse, alteration, accident or which have been improperly/inadequately maintained.

Notice Procedure:

In order to make a valid warranty claim a written notice of the claim must be submitted, using the RMA form, within 60 days of discovery of a warrantable nonconformance. The RMA form is found on the OneGSI portal.

Service Parts:

GSI warrants, subject to all other conditions described in this Warranty, Service Parts which it manufactures for a period of 12 months from the date of purchase unless specified in Enhancements above.

This equipment shall be installed in accordance with the current installation codes and applicable regulations which should be carefully followed in all cases. Authorities having jurisdiction should be consulted before installations are made.

G S I G R O U P



GSI Group
1004 E. Illinois St.
Assumption, IL 62510-0020
Phone: 1-217-226-4421
Fax: 1-217-226-4420
www.gsiag.com