

# Top Dry 21', 24', 30', & 36' Manual Batch

Construction & Owner's Manual

**PNEG-1510**

Date: 06-19-2006



a division of  
THE GSI GROUP



PNEG-1510



---

# Table of Contents

Safety Guidelines .....	5
Decals .....	7
Foundation Requirements .....	9
Circular Foundation Form .....	10
Octagonal Foundation Form .....	11
Inline Centrifugal Fan Pad .....	12
Duct & Drying Fan Pad Optional .....	13
Frost Free Foundation Top Dry Bins .....	14
Frost Free Pad .....	15
Anchor Bolt Placement .....	16
Hardware/Bolting Requirements .....	17
Location of Accessories .....	20
Sidewall & Stiffener Gauges .....	22-23
Outside Stiffeners .....	24
Top Stiffener Starting Location .....	25
Bolting Requirements .....	27
Stiffener & Seam Locations .....	28
Sidewall Erection Instructions .....	29
Sidewall Construction Instructions .....	30
Lifting Jacks & Brackets .....	31
Lifting Jack Usage .....	32
"C"-Channel Bracket Installation .....	33
"C" Channel Installation .....	34
Center Collar Assembly .....	35
Rafter Installation & Floor Support Angle Attachment .....	36
21' Special Angle Purlin Assembly .....	37
24' Intermediate Purlin .....	38
30' Intermediate Purlin .....	39
36' Intermediate Purlin .....	40
Dump Hopper Installation/Floor Sheet Installation .....	41
21'&24' Leveling Band Post Installation .....	42
Flashing Bolt Installation/Eave Flashing Installation .....	45-46
Outer Dump Chutes .....	47
Center Cone Assembly/Center Cone Installation .....	48
Roof Assembly/Leveling Band Location .....	49-52
Pulley Assembly .....	53

---

Dump Chute Chain Assembly .....	54
Winch Assembly .....	56
Fan Entrance Sheets .....	57
Top Dry Access Door Assembly .....	58
Detailed Layout For Proper Location Of Platforms .....	59
Access Door Platform .....	60
Large Platform Assembly .....	61
42" Fan Diffuser Instructions & Installation .....	63
Cross Over Platform Assembly .....	65
Perforated Center Band .....	66
Optional Rotary Switch Roof Locations .....	67
Optional Installation of Roof Mounted Level Switches .....	68
Optional Installation of Wall-Mounted Rotary Switches .....	69
Transition Installation (TR-4734) .....	70
Transition Assembly (TR-4734) Two Ring Door Installation Instructions .....	72
Two Ring Door Assembly .....	73
Part List for Two Ring Doors .....	74
Optional Bin Step Assembly .....	75
Base Angle Detail .....	76
Warranty .....	Inside Back Cover

---

## SAFETY GUIDELINES

This manual contains information that is important for you, the owner/operator, to know and understand. This information relates to protecting **personal safety** and **preventing equipment problems**. It is the responsibility of the owner/operator to inform anyone operating or working in the area of this equipment of these safety guidelines. To help you recognize this information, we use the symbols that are defined below. Please read the manual and pay attention to these sections. Failure to read this manual and its safety instructions is a misuse of the equipment and may lead to serious injury or death.



**This is the safety alert symbol. It is used to alert you to potential personal injury hazards. Obey all safety messages that follow this symbol to avoid possible injury or death.**



**DANGER**

**DANGER** indicates an imminently hazardous situation which, if not avoided, will result in death or serious injury.



**WARNING**

**WARNING** indicates a potentially hazardous situation which, if not avoided, could result in death or serious injury.



**CAUTION**

**CAUTION** indicates a potentially hazardous situation which, if not avoided, may result in minor or moderate injury.



**CAUTION**

**CAUTION** used without the safety alert symbol indicates a potentially hazardous situation which, if not avoided, may result in property damage.



**NOTE**

**NOTE** indicates information about the equipment that you should pay special attention to.



GSI DOES NOT WARRANT ANY ROOF DAMAGE CAUSED BY EXCESSIVE VACUUM OR INTERNAL PRESSURE FROM FANS OR OTHER AIR MOVING SYSTEMS. ADEQUATE VENTILATION AND/OR "MAKEUP AIR" DEVICES SHOULD BE PROVIDED FOR ALL POWERED AIR HANDLING SYSTEMS. GSI DOES NOT RECOMMEND THE USE OF DOWNWARD FLOW SYSTEMS (SUCTION). SEVERE ROOF DAMAGE CAN RESULT FROM ANY BLOCKAGE OF AIR PASSAGES. RUNNING FANS DURING HIGH HUMIDITY/COLD WEATHER CONDITIONS CAN CAUSE AIR EXHAUST OR INTAKE PORTS TO FREEZE.

## DECALS

ATTENTION: The decal shown below should be present on the inside of the door cover of the two ring, 24" porthole door cover and the roof manway cover.

Grain Systems  
1004 East Illinois Street  
Assumption, Il. 62510-0020  
(217) 226-4421



# DANGER



**Rotating flighting can kill or dismember.**



**Flowing material can trap and suffocate.**



**Crusted material can collapse and suffocate.**

## Keep clear of all augers. DO NOT ENTER this bin!

---

**If you must enter this bin:**

1. Shut off and lock out all power.
2. Use safety harness and safety line.
3. Station another person outside the bin.
4. Avoid the center of the bin.
5. Wear proper breathing equipment or respirator.

---

## Failure to heed these warnings will result in serious injury or death

ATTENTION: The decal shown below should be present on the outside of the door cover of the two ring, 24" porthole door cover and the roof manway cover.

Grain Systems  
1004 East Illinois Street  
Assumption, Il. 62510-0020  
(217) 226-4421



# CAUTION

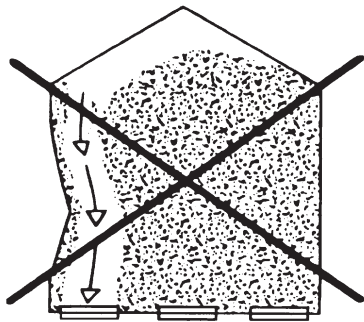

**DON'T**

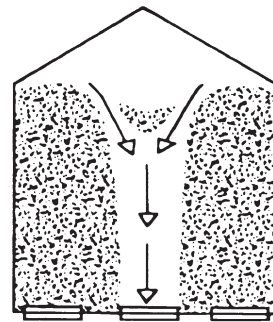

**DO**

## UNLOADING INSTRUCTIONS:

1. Use **CENTER OUTLET ONLY** until **NO** grain remains above this outlet.
2. Side outlets to be used **ONLY** when above condition is satisfied.
3. Lock all side outlets to avoid accidental premature use.

**Failure to follow proper unloading practices will result in structural damage or collapse of tank.**

DC-566



---

# FOUNDATION REQUIREMENTS FOR TOP DRY BINS (4.00" "TOP DRY" BIN CORRUGATION)

## 1. REQUIREMENTS:

The following foundation recommendations are a revision to earlier manuals distributed by The GSI Group, Inc.

**Note:** There are changes in foundation dimensions from past publications. These dimensions are critical to the proper installation and function of each foundation.

## 2. SELECTING THE PROPER SITE:

The selected site should be level, firm, and free from underlying debris. The bin can be installed satisfactorily on slopes, but as the slope increases, additional labor and materials are required for the foundation. The concrete foundation surface must be level. If some fill is required, it should be watered and tamped thoroughly to prevent uneven settling from the weight of the bin. Naturally, the site must allow convenient access for easy loading and unloading, plus provide additional space for future units. Also consider the positioning of handling equipment, availability of electricity, and the placement of fans, heaters, and gas tanks.

## 3. SCRIBE THE DIAMETER

Having determined the center of the site, drive a small 2 x 4 in the ground to mark the center point of the foundation. The top of the stake should be the same height as the finished foundation will be. Using one large spike, nail a straight 2 x 4 (approximately 2 ft. longer than the radius of the bin) to the top of the center spike. The swiveling 2 x 4 will act as a compass, enabling you to scribe the correct diameter of your foundation and later locate the anchor and stiffener bolt locations. (Note: Making the 2 x 4 two feet longer than the radius allow the 2 x 4 to also be used as a leveling device and for pulling concrete).

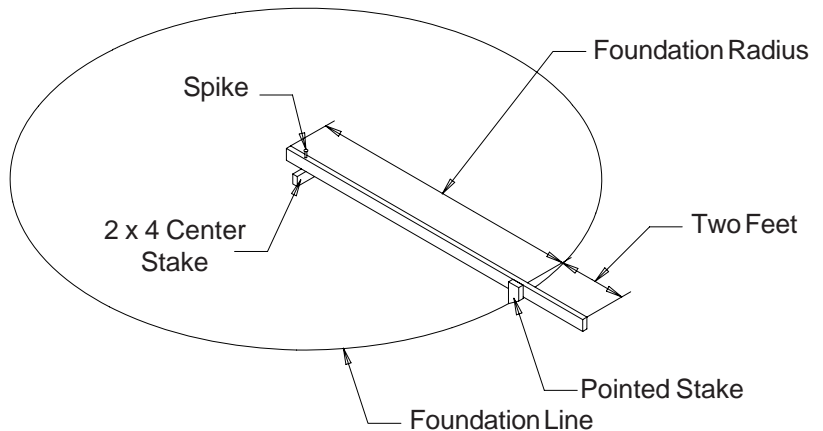
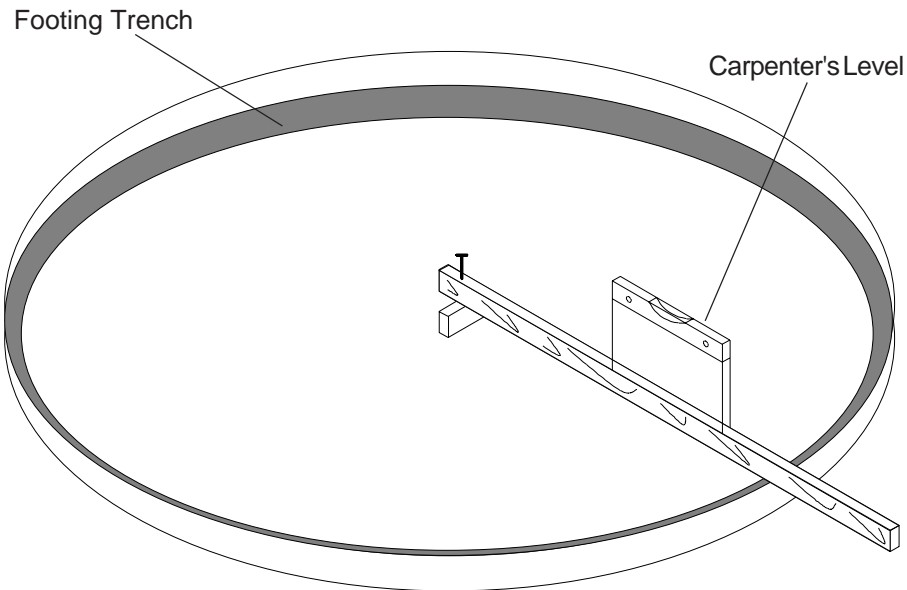

Figure #1

---

## CIRCULAR FOUNDATION FORM



**Figure #2**

### 4. PREPARE THE FOUNDATION

Having scribed the diameter of your foundation, proceed by digging the footing of the foundation. This consists of a large circular trench dug just inside the foundation line. (Refer to foundation details for necessary information.) Once the footing has been dug, you are ready to build the forms. It is important that your form be rigid enough to hold its shape against the poured concrete. Also, the foundation must be flat. Sloped floors cannot be used in drying bins. A carpenter's level placed on top of your 2 x 4 will enable you to set the top of the forms to match the top of the center stake. Check the form work with a transit to ensure a uniform elevation for the entire foundation.

---

## OCTAGONAL FOUNDATION FORM

There are two styles of foundation forms commonly used. The first is the circular form depicted in Figure #2. The second style can be made of 2" x 8" boards set into a square with corners blocked off to form an octagon. (See Figure #3 below.) This eight sided form will approximate a circle and can be constructed quite easily.

When the foundation form is completed install reinforcement rods by either welding or wiring in place. Place 2" of compacted sand on the inside level of the foundation. The sand is then covered with a 4 mil plastic moisture barrier. 6" x 6" wire mesh (2 mats), covering the entire area of the foundation, completes your preparation of the bin's foundation. You are now ready to begin pouring concrete.

**NOTE: ALL CONCRETE IS TO HAVE A MINIMUM COMPRESSIVE STRENGTH OF 3,000 PSI @ 28 DAYS.**

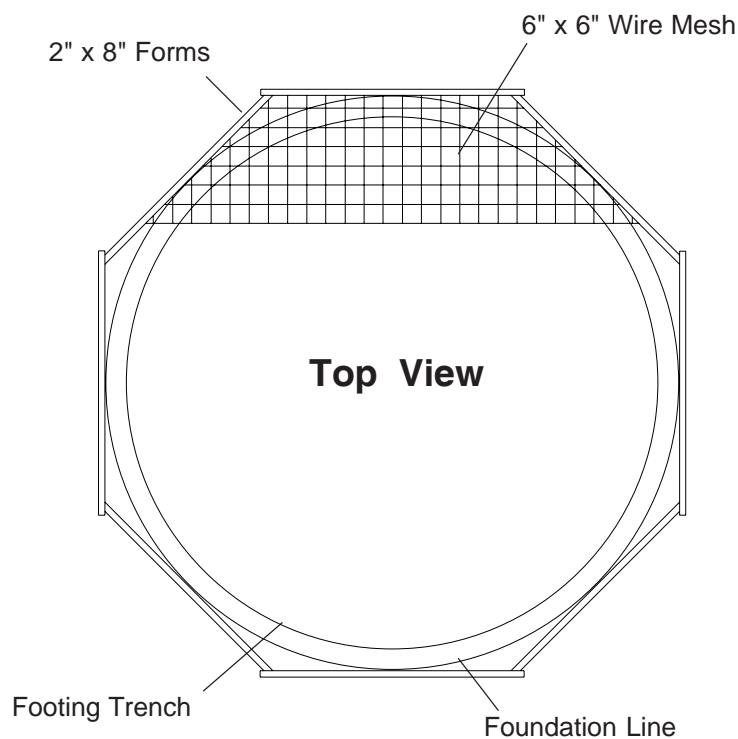

**Figure #3**

# INLINE CENTRIFUGAL FAN PAD

## 5. PLACEMENT OF THE FAN PAD: G.S.I TRANSITIONS / FANS ONLY.

If a fan is to be installed, refer to the following diagram to determine the concrete pad size.

- The top of this pad should be level with the top of the bin's foundation.
- Recommended pad thickness is 4" minimum.
- Front of pad should be perpendicular to bin wall.
- Pad for heater not required.

### IMPORTANT!

FAN PAD AND FAN MUST BE LEVEL AND SMOOTH FOR PROPER OPERATION. VIBRATION PROBLEMS CAN RESULT FROM IMPROPER FAN LEVELING.

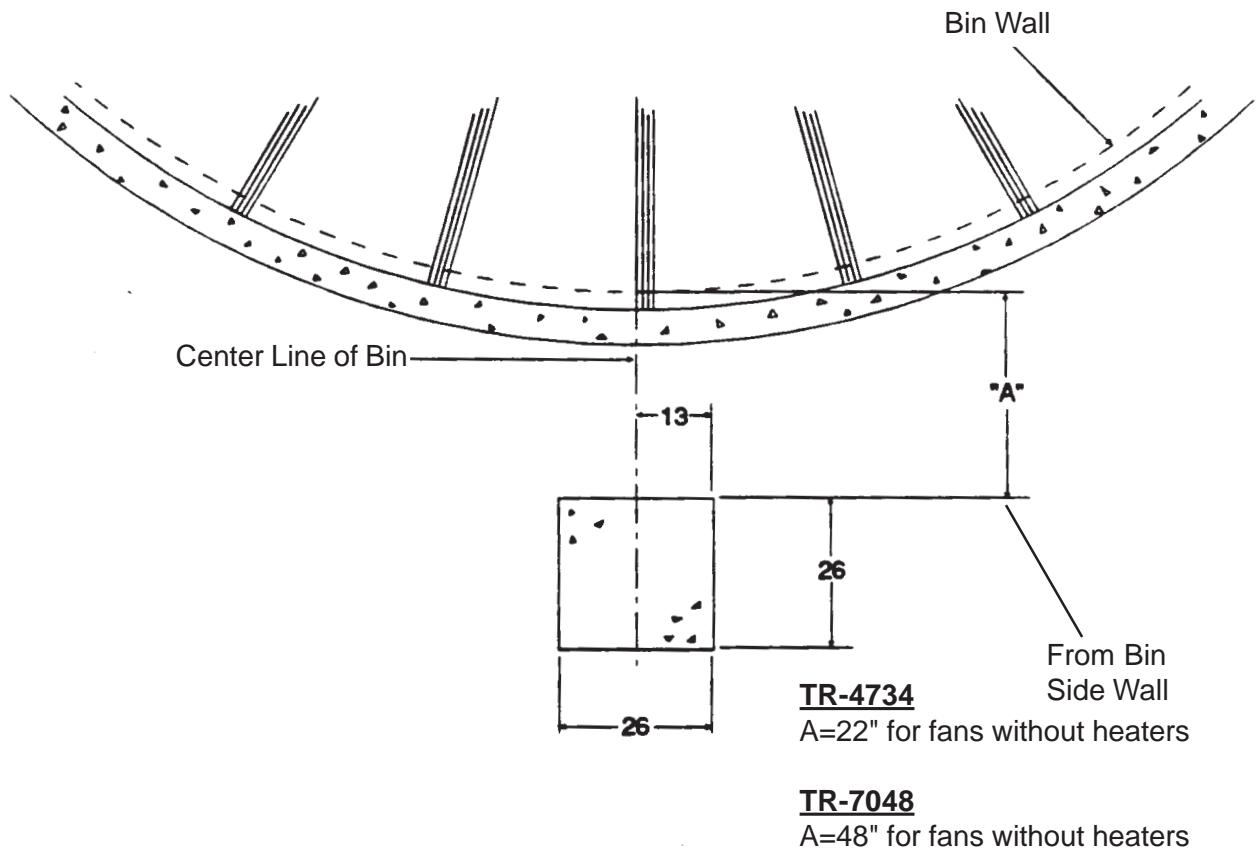

Figure #4

---

## DUCT & DRYING FAN PAD OPTIONAL

### 6. PLACEMENT OF THE DUCT FAN PAD: G.S.I TOP DRY DUCT SYSTEM ONLY.

Refer to the following diagram to determine the duct pad size.

The top of this pad should be level with the top of the bin's foundation.  
Recommended pad thickness is 4" minimum.  
Front of pad should be perpendicular to bin wall.

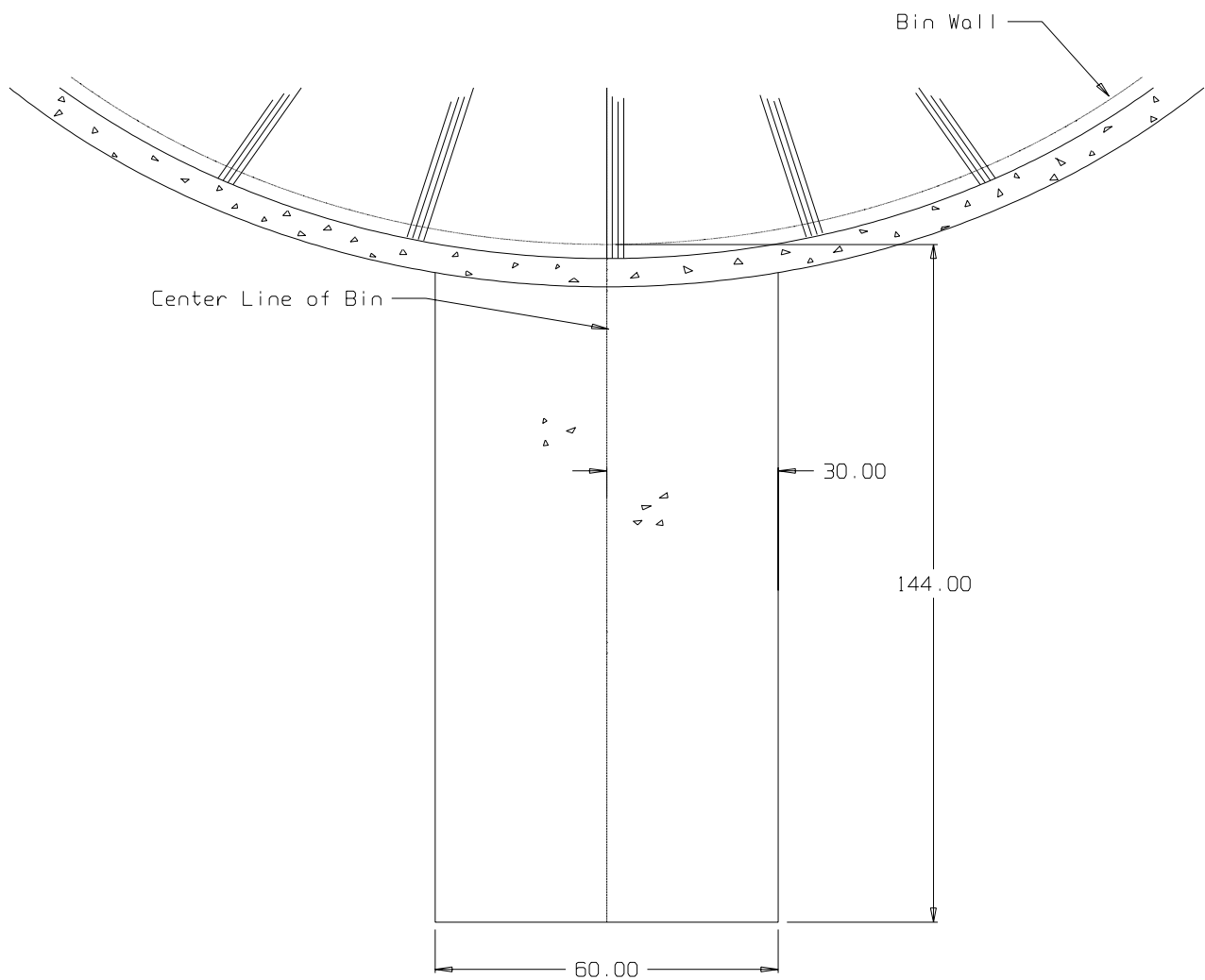

**Figure #5**

## FROST FREE FOUNDATION TOP DRY BINS

Diameter of Bin: 21'  
Corrugation: 4.00"

Ring No.	B	N	OutSide Radius	Sq. Ft. Mesh 6x6 -6/6	Optional #4 18"x18"Grid(ft.)	Length #6 Bar (ft.)	Total Cu.Yds. Concrete
6	1 ft. 1 in.	2	11 ft. 3 in.	700	500	200	11
7,8	1 ft. 7 in.	2	11 ft. 3 in.	700	500	200	12

Diameter of Bin: 24'  
Corrugation: 4.00"

Ring No.	B	N	Outside Radius	Sq. Ft. Mesh 6x6-6/6	Optional #4 18"x18" Grid (ft.)	Length #6 Bar (ft.)	Total Cu. Yds. Concrete
6	1 ft. 1 in.	2	12 ft. 9 in.	900	600	200	13
7,8	1 ft. 9 in.	2	12 ft. 9 in.	900	600	200	15
9,10	2 ft. 6 in.	3	13 ft. 2 in.	900	600	400	18

Diameter of Bin: 30'  
Corrugation: 4.00"

Ring No.	B	N	Outside Radius	Sq. Ft. Mesh 6x6-6/6	Optional #4 18"x18" Grid (ft.)	Length #6 Bar (ft.)	Total Cu. Yds. Concrete
6	1 ft. 2 in.	2	15 ft. 9 in.	1400	900	200	19
7,8	1 ft. 10 in.	2	15 ft. 10 in.	1400	900	200	21
9,10	2 ft. 8 in.	3	16 ft. 1 in.	1400	900	500	25
11	3 ft. 8 in.	4	16 ft. 5 in.	1400	900	700	29

Diameter of Bin: 36'  
Corrugation: 4.00"

Ring No.	B	N	Outside Radius	Sq. Ft. Mesh 6x6-6/6	Optional #4 18"x18" Grid (ft.)	Length #6 Bar (ft.)	Total Cu. Yds. Concrete
6	1 ft. 3 in.	2	18 ft. 9 in.	2000	1300	300	26
7,8	2 ft. 0 in.	2	18 ft. 11 in.	2000	1300	400	30
9,10	2 ft. 10 in.	3	19 ft. 0 in.	2000	1300	600	33
11,12	3 ft. 11 in.	4	19 ft. 6 in.	2000	1300	900	39

# FROST FREE PAD

## NOTES:

- Foundation site should be well drained and free of vegetation or debris.
- Foundation design is based on a minimum soil bearing capacity of 3,000 lb/ft<sup>2</sup>. If soil bearing capacity is in doubt, contact a local soil testing engineer.
- Concrete shall have a minimum compressive strength of 3,000 PSI at 28 days.
- Requirements for reinforcement do not include overlap.
- Lap all circumferential bars 35 bar diameters and stagger all laps in plan 3'-0".
- All material used for back fill inside the ring wall should be a clean, well graded, crushed stone or sand-gravel mixture. Back fill should be placed in 6" lifts and well compacted.

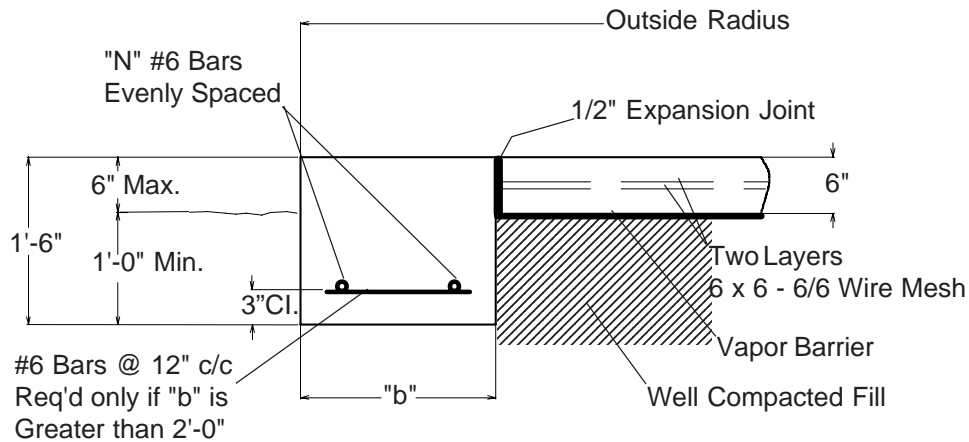

**Figure #6**

21' Diameter Bin

Ring Number	5	6	7	8
b	1'-1"	1'-1"	1'-7"	1'-7"
N	2	2	2	2
Outside Radius	11'-3"	11'-3"	11'-3"	11'-3"
Sq. Ft. Mesh 6 x 6 - 6/6	700	700	700	700
Length of #6 Bars	200	200	200	200
Total Cubic Yd. Concrete	11	11	12	12

# ANCHOR BOLT PLACEMENT

## Anchor Bolt Placement

Having poured and leveled the concrete, use the center stake and straight 2" x 4" again to find the bolt circle radius for the outside hold down brackets. Select a starting point and stretch a premeasured chord along the imaginary circle formed by the bolt circle radius. Take into consideration the placement of these bolts so as not to interfere with the positions of bin doors and transitions. (Refer to the following chart for necessary radii and chord lengths.) Take your time and work carefully since accuracy is important.

Work both directions from first anchor bolt location, this will help eliminate possible error in laying out anchor bolts. On larger bins sight across starting anchor bolt and center pin and place anchor bolt on opposite side of anchor bolt radius. From this point you can work both directions from both anchor bolts.

*NOTE: Top edge of slab where the bin wall sets must be held to within 1/8" of level.*

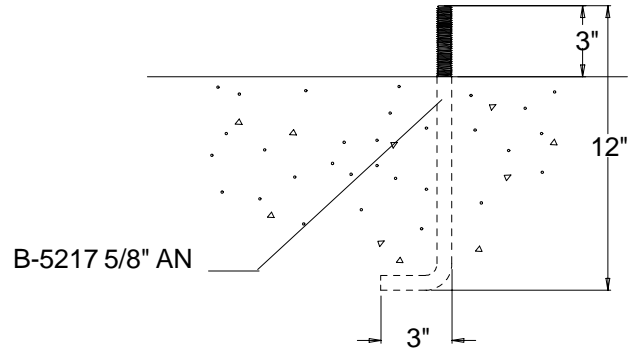

**Anchor Bolt**

Bin Dia	"B" Bolt Circle Radius	No. of Anchors	"E" Chord Distance
12'	6'-3.1/4"	8	4'-9.9/16"
15'	7'-9.1/8"	10	4'-9.9/16"
18'	9'-3.1/16"	12	4'-9.1/2"
21'	10'-8.15/16"	14	4'-9.3/8"
24'	12'-2.7/8"	16	4'-9.5/16"
27'	13'-8.3/4"	18	4'-9.1/4"
30'	15'-2.11/16"	20	4'-9.1/8"
33'	16'-8.9/16"	22	4'-9.1/16"
36'	18'-2.1/2"	24	4'-9.1/16"
42'	21'-2.5/16"	28	4'-8.15/16"
48'	24'-2.1/8"	32	4'-8.7/8"
54'	27'-1.15/16"	36	4'-8.13/16"
60'	30'-1.3/4"	40	4'-8.3/4"

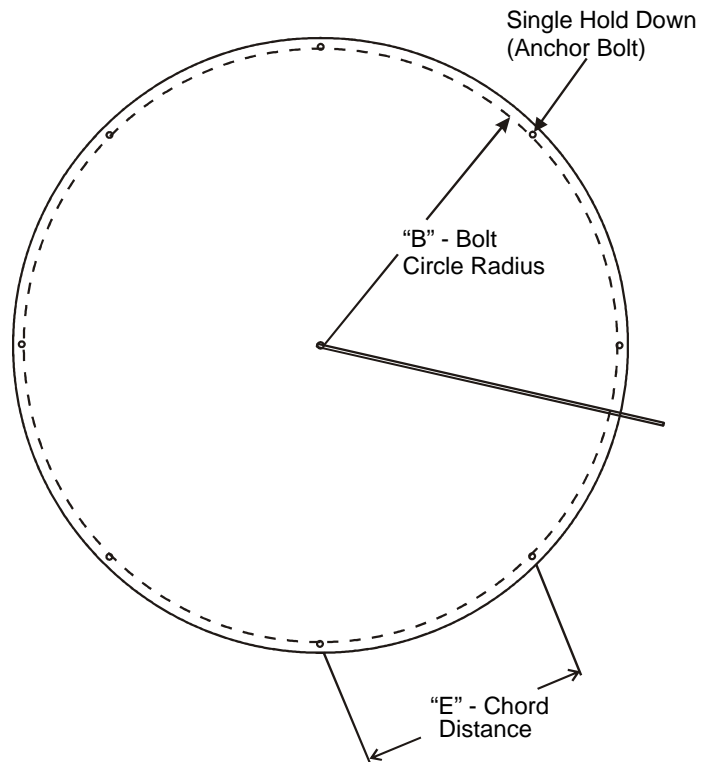
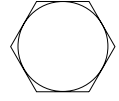

**Figure #7**



## HARDWARE/BOLTING REQUIREMENTS

**NOTE:** Grade 2 bolts are designated with a plain head.



**NOTE:** Grade 5 bolts are designated by 3 slash marks on the head.  
All 5/16" diameter bolts are to be Grade 5 or higher.

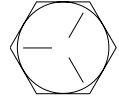

**NOTE:** Grade 8 bolts are designated by 6 slash marks on the head.

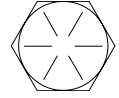

**NOTE:** Grade 8.2 bolts are designated by 6 slash marks on the head in a sunrise pattern.  
All 3/8" diameter bolts are to be Grade 8 or 8.2.

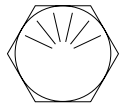

**IMPORTANT:** Do not tighten bolts to exceed the torque specifications listed below.

BOLT SIZE	TORQUE (ft. lb.)	
	MINIMUM	MAXIMUM
5/16"-18	15	20
3/8"-16	35	42
7/16" - 14	65	72
1/2" - 13	95	105

**CAUTION: UNDER NO CONDITION SHALL ANY OTHER BOLTS BE SUBSTITUTED FOR THOSE SUPPLIED BY GRAIN SYSTEMS, INC.**

**IMPORTANT: HARDWARE USAGE** - 20 gauge - 15 gauge sidewall sheets, use 5/16" x 3/4" bolts and nuts. (S-275)

14 gauge and 13 gauge sidewall sheets, use 5/16" X 3/4" bolts and nuts. (S-275)

- Use 5/16" x 1.1/4" (S-277) for attaching floor flashing to the sidewall.

---

**REFER TO TOP DRY TANK BOLTING REQUIREMENTS  
FOR COMPLETE BOLT USAGE**

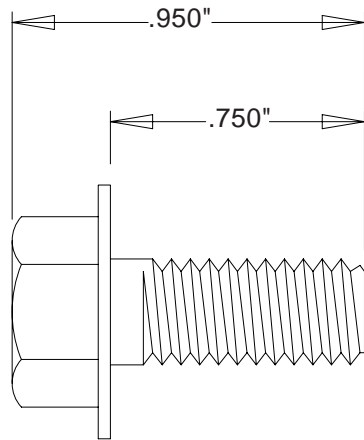

**SIDE VIEW**

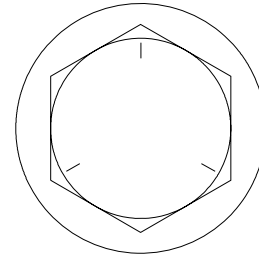

**GRADE 5**

**TOP VIEW**

**S-275**

.3125" x .750" pre-assembled with a steel backed neoprene washer.

This bolt is used to connect horizontal and vertical seams for 13 gage and thinner sidewall sheets to each other, and to bolt the stiffeners to the sidewall sheets. It is also used in attaching roof panels to the top sidewall sheet and attaching roof panels and flashing to the center collar.

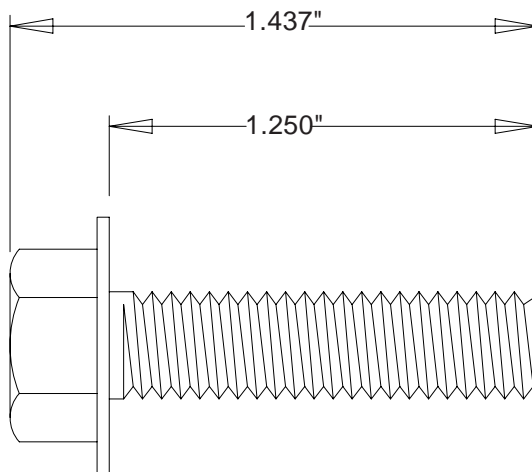

**SIDE VIEW**

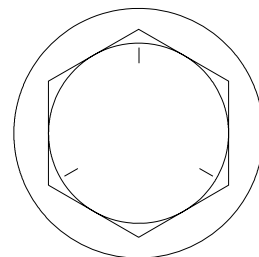

**GRADE 5**

**TOP VIEW**

**S-277**

.3125" x 1.250" pre-assembled with a steel backed neoprene washer.

This bolt is primarily used to connect roof panels together where they overlap. It is also used at the bottom of the flat bottomed bins to attach the base angle to the sidewall sheet. A small number of these are provided for joints and FC-42076 splice plates for the stiffeners to sidewall connection.

**Figure #8**

**REFER TO TOP DRY TANK BOLTING REQUIREMENTS  
FOR COMPLETE BOLT USAGE**

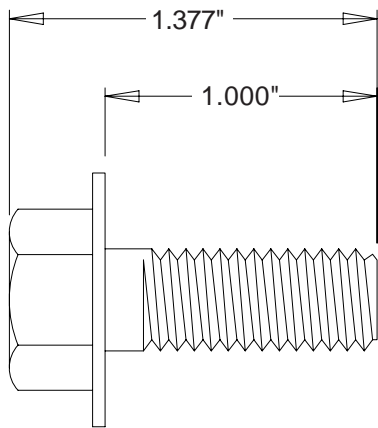

**SIDE VIEW**

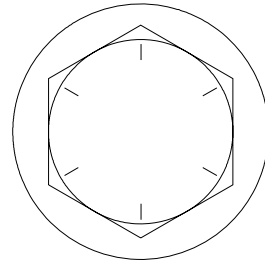

**GRADE 8**

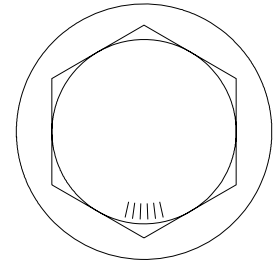

**GRADE 8.2**

**TOP VIEW**

**S-7927**

.375" x 1.000" hex flanged head **without** a plastic sealing washer.

This bolt is used to splice the stiffeners together on the flanges. A steel flat washer is used on the nut side of the connection. They are also used on "c" channel splices and mounting "c" channel to wall bracket.

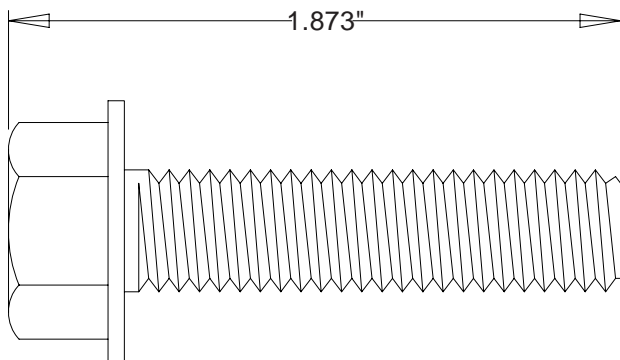

**SIDE VIEW**

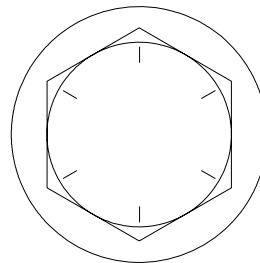

**GRADE 8**

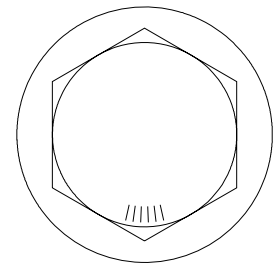

**GRADE 8.2**

**TOP VIEW**

**S-7928**

.375" x 1.500" hex flanged head **without** a plastic sealing washer.

This bolt is used to attach the wall bracket to the sidewall and stiffener. A steel flat washer is used on the nut side of the connection.

Note: The only washers shipped loose with the bins are the steel flat washers. The 5/16" steel flat washer (S-845) is used where the base angle attaches to the sheet and some are used at the main eave clips. The 3/8" steel flat washers (S-248) are used at the stiffener splices and some are used in the roof rafter splices.

**Figure #9**

## LOCATION OF ACCESSORIES

Below is a typical Top Dry bin layout showing suggested locations of Top Dry Accessories. When locating the manway be sure the outside ladder will not interfere with other accessories below. Roof vents should be spaced evenly around the roof. (Quantity will vary with individual systems.)

**NOTE:** The Top Dry system should be provided with a dependable equipment ground.

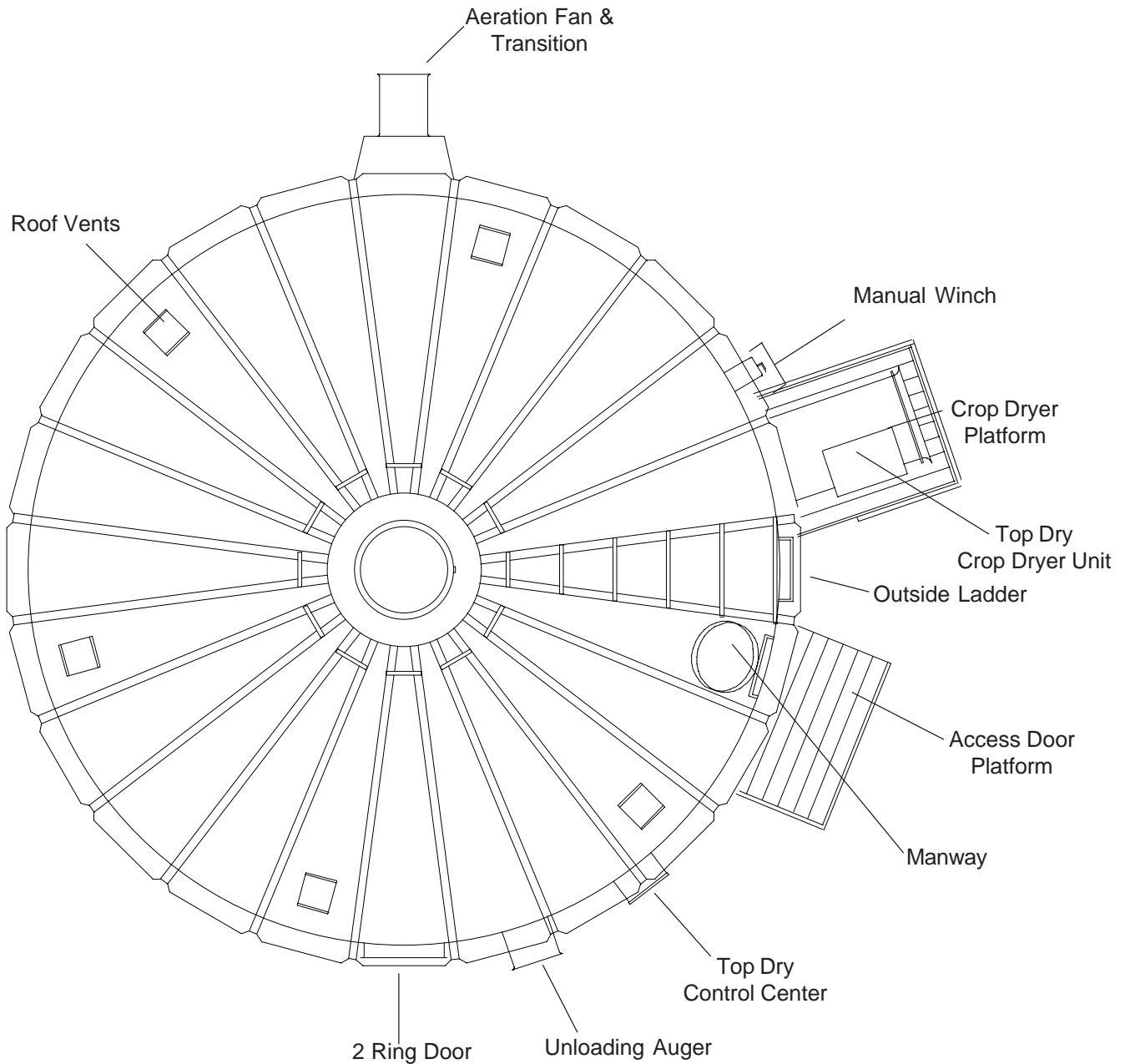

**Figure #10**

---

## VERY IMPORTANT

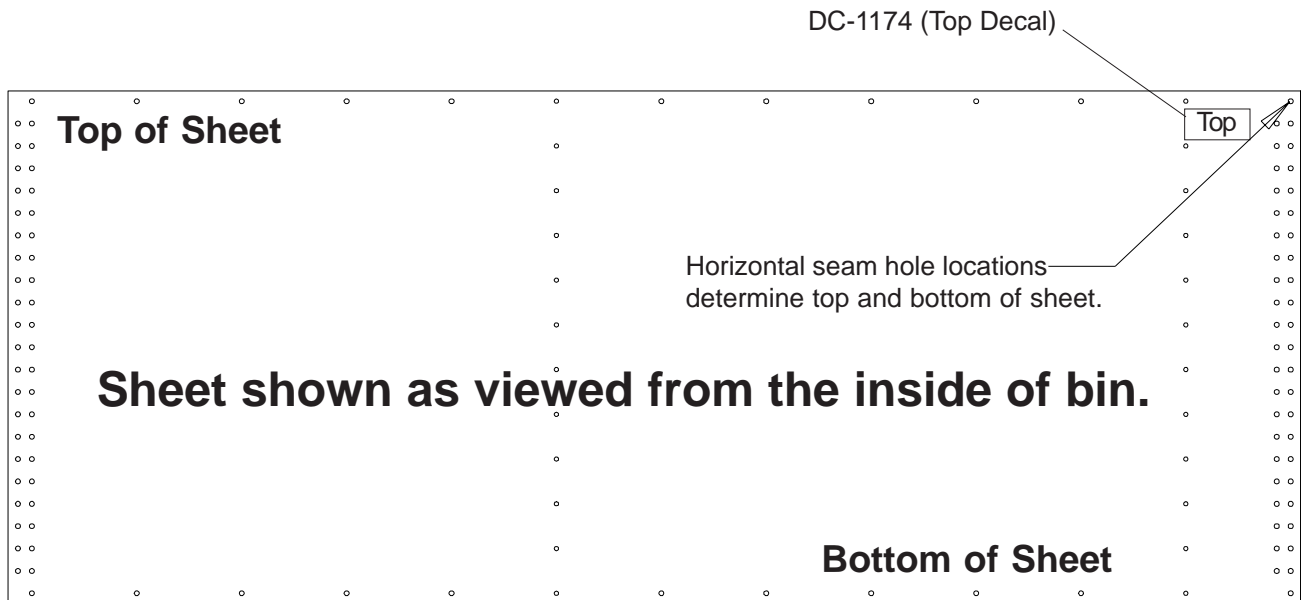

Figure #11

**All 4.00" corrugated sidewall sheets must be placed correctly.**

**All 4.00" corrugated sidewall sheets have a top and bottom!**

**Failure to observe this will not allow the door to fit properly.**

**Carefully review the erection manual and place sidewall sheets as shown.**

## SIDEWALL GAUGES

TANK DIA. (FT.)	NUMBER OF RINGS OF SIDEWALL	Sidew all Base Ring	Sidew all Ring #2	Sidew all Ring #3	Sidew all Ring #4	Sidew all Ring #5	Sidew all Ring #6	Sidew all Ring #7	Sidew all Ring #8	Sidew all Ring #9	Sidew all Ring #10	Sidew all Ring #11
21	5	20ga	20ga	20ga	20ga	20ga						
21	6	20ga	20ga	20ga	20ga	20ga	20ga					
21	7	20ga	20ga	20ga	20ga	20ga	20ga	20ga				
21	8	18ga	20ga	20ga	20ga	20ga	20ga	20ga	20ga			
24	5	20ga	20ga	20ga	20ga	20ga						
24	6	20ga	20ga	20ga	20ga	20ga	20ga					
24	7	18ga	20ga	20ga	20ga	20ga	20ga	20ga				
24	8	18ga	18ga	20ga	20ga	20ga	20ga	20ga	20ga			
24	9	17ga	18ga	18ga	20ga	20ga	20ga	20ga	20ga	20ga		
24	10	17ga	17ga	18ga	18ga	18ga	20ga	20ga	20ga	20ga	20ga	
30	5	18ga	18ga	18ga	18ga	20ga						
30	6	18ga	18ga	18ga	18ga	18ga	20ga					
30	7	17ga	18ga	18ga	18ga	18ga	18ga	20ga				
30	8	17ga	17ga	18ga	18ga	18ga	18ga	18ga	20ga			
30	9	17ga	17ga	17ga	18ga	18ga	18ga	18ga	18ga	20ga		
30	10	16ga	17ga	17ga	17ga	18ga	18ga	18ga	18ga	18ga	20ga	
30	11	16ga	17ga	17ga	17ga	17ga	18ga	18ga	18ga	18ga	18ga	20ga
36	5	17ga	18ga	18ga	18ga	20ga						
36	6	17ga	18ga	18ga	18ga	18ga	20ga					
36	7	16ga	17ga	18ga	18ga	18ga	18ga	20ga				
36	8	16ga	16ga	17ga	18ga	18ga	18ga	18ga	20ga			
36	9	16ga	16ga	16ga	17ga	18ga	18ga	18ga	18ga	20ga		
36	10	15ga	16ga	16ga	16ga	17ga	18ga	18ga	18ga	18ga	20ga	
36	11	14ga	15ga	15ga	16ga	16ga	17ga	18ga	18ga	18ga	18ga	20ga

**NOTE:** Fan Entrance sheets and Plenum Access door sheets are located in the second ring from the top of the bin, just below the upper drying floor.

## STIFFENER GAUGES

NOMINAL DIA. OF SIDEWALL (Ft)	NUMBER OF RINGS OF SIDEWALL	Stiffener Base Ring	Stiffener Ring #2	Stiffener Ring #3	Stiffener Ring #4	Stiffener Ring #5	Stiffener Ring #6	Stiffener Ring #7	Stiffener Ring #8	Stiffener Ring #9	Stiffener Ring #10	Stiffener Ring #11
21	5		14ga	16ga	16ga	16ga						
21	6		14ga		16ga	16ga	16ga					
21	7		12ga		14ga	16ga	16ga	16ga				
21	8		12ga		14ga		16ga	16ga	16ga			
24	5		14ga	16ga	16ga	16ga						
24	6		12ga		14ga	16ga	16ga					
24	7		12ga		14ga	16ga	16ga	16ga				
24	8		12ga		14ga		12ga	16ga	16ga			
24	9		10ga		12ga		12ga	14ga	14ga	16ga		
24	10		8ga		10ga		12ga		14ga	16ga	16ga	
30	5		12ga	14ga	16ga	16ga						
30	6		12ga		14ga	16ga	16ga					
30	7		12ga		12ga	14ga	16ga	16ga				
30	8		10ga		12ga		14ga	16ga	16ga			
30	9		10ga		12ga		12ga	14ga	16ga	16ga		
30	10		8ga		10ga		12ga		14ga	16ga	16ga	
30	11		8ga		10ga		12ga		12ga	14ga	16ga	16ga
36	5		12ga	14ga	16ga	16ga						
36	6		12ga		12ga	14ga	16ga					
36	7		10ga		12ga	14ga	14ga	16ga				
36	8		10ga		12ga		12ga	14ga	16ga			
36	9		8ga		10ga		12ga	14ga	14ga	16ga		
36	10		8ga		10ga		12ga		12ga	14ga	16ga	
36	11		8ga		8ga		10ga		12ga	14ga	14ga	16ga

**NOTE: All Top Dry Bin Stiffeners are mounted on the outside of the bin. See Stiffener instructions for stiffener joint details and stiffener to sidewall attachment.**

# OUTSIDE STIFFENERS

- The XX in the part numbers at the bottom will identify the Stiffener's gauge.
- Example: FC-4205714 is a 2-Ring Standard Stiffener 14 Gauge.

Stiffener Description	Part No.	Overall Length	Color Code
2-Ring 10 Ga. (Base)	FC-4207210	94 27/32"	White
2-Ring 12 Ga. (Base)	FC-4207212	94 27/32"	Black
2-Ring 14 Ga. (Base)	FC-4207214	94 27/32"	Green
2-Ring 16 Ga. (Base)	FC-4207216	93 13/16"	Blue
2-Ring 8 Ga. (Base)	FC-4207308	88 3/16"	Yellow
2-Ring 8 Ga.	FC-4206308	87 15/16"	Yellow
2-Ring 10 Ga. Trans.	FC-42062	94 19/32"	Purple
2-Ring 12 Ga.	FC-4205712	94 19/32"	Black
2-Ring 14 Ga.	FC-4205714	94 19/32"	Green
2-Ring 16 Ga.	FC-4207516	93 9/16"	Blue
2-Ring 18 Ga.	FC-4207518	93 9/16"	Orange
2-Ring 16 Ga. Top	FC-4206516	85 9/16"	Blue
2-Ring 18 Ga. Top	FC-4206518	85 9/16"	Orange
1-Ring 12 Ga.	FC-4205912	50 19/32"	Black
1-Ring 14 Ga.	FC-4205914	50 19/32"	Green
1-Ring 16 Ga.	FC-4207416	49 9/16"	Blue
1-Ring 18 Ga.	FC-4207418	49 9/16"	Orange
1-Ring Top 16 Ga.	FC-4206616	41 7/16"	Blue
1-Ring Top 18 Ga.	FC-4206618	41 7/16"	Orange
Splice	FC-42076	10 11/16"	---

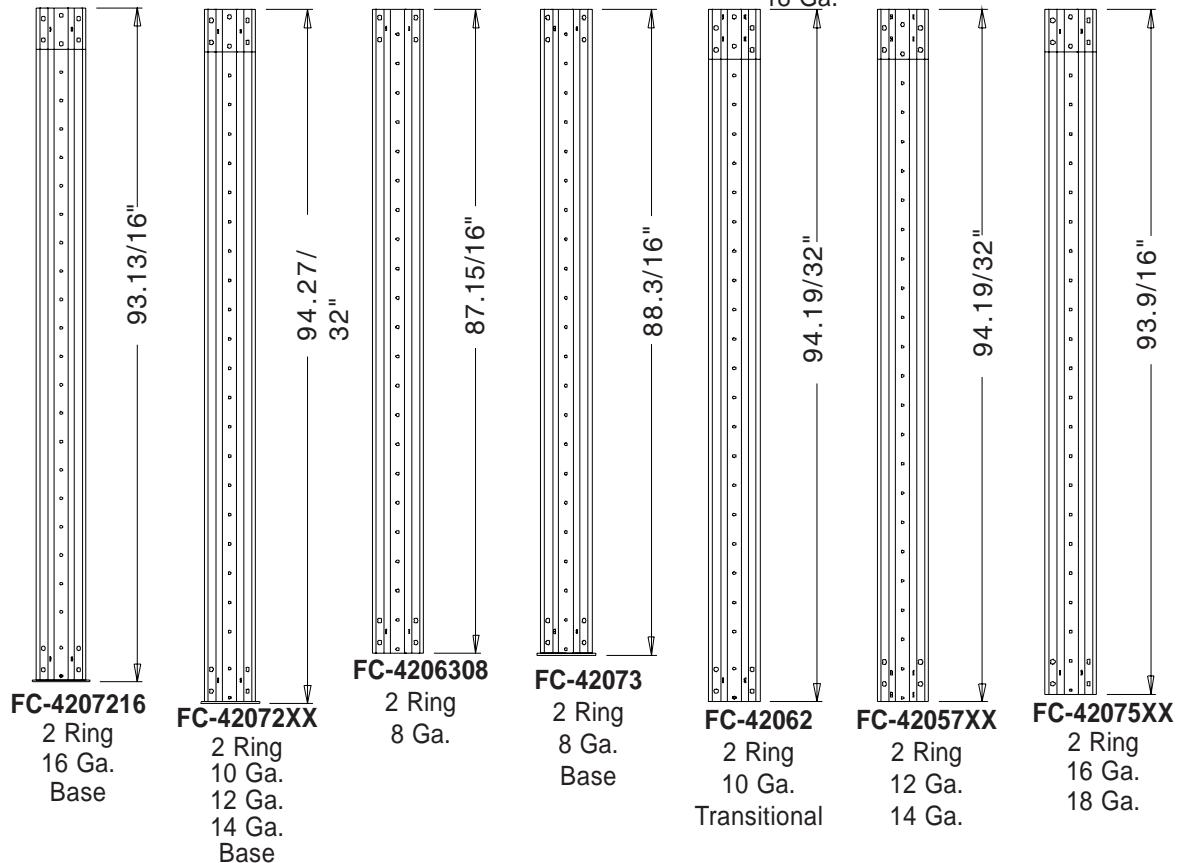
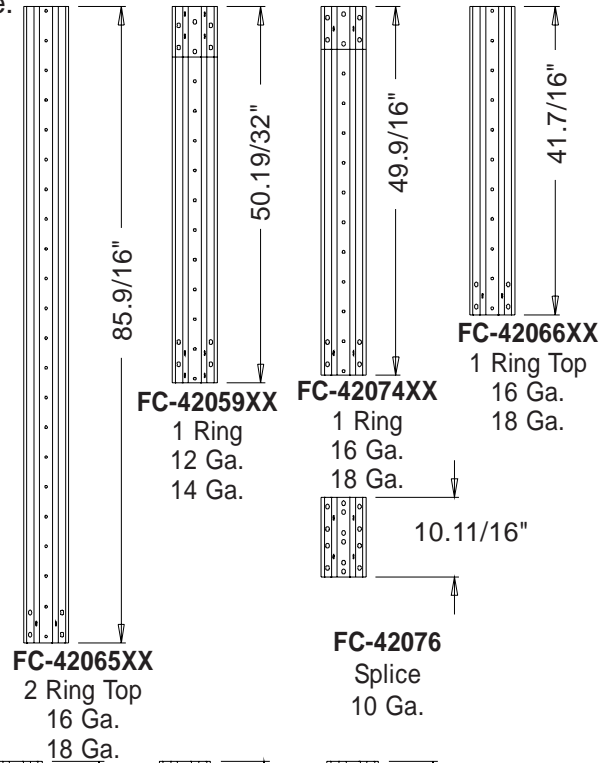

**Figure #12**



## TOP STIFFENER STARTING LOCATION

Refer to Figure #13, for proper location of top stiffeners. On the overlap of the stiffeners, and on the splice, use 3/8" x 1" hex bolts, a washer on the nut side connection. Refer to the sidewall gauges, and stiffener usage.

All stiffeners are outside the bin wall. Use 5/16" x 3/4" Grade 5 bin bolts with head and neoprene washer to the inside of the bin wall. Refer to proper charts and illustrations on the previous two pages for proper location of stiffeners and sidewall sheets.

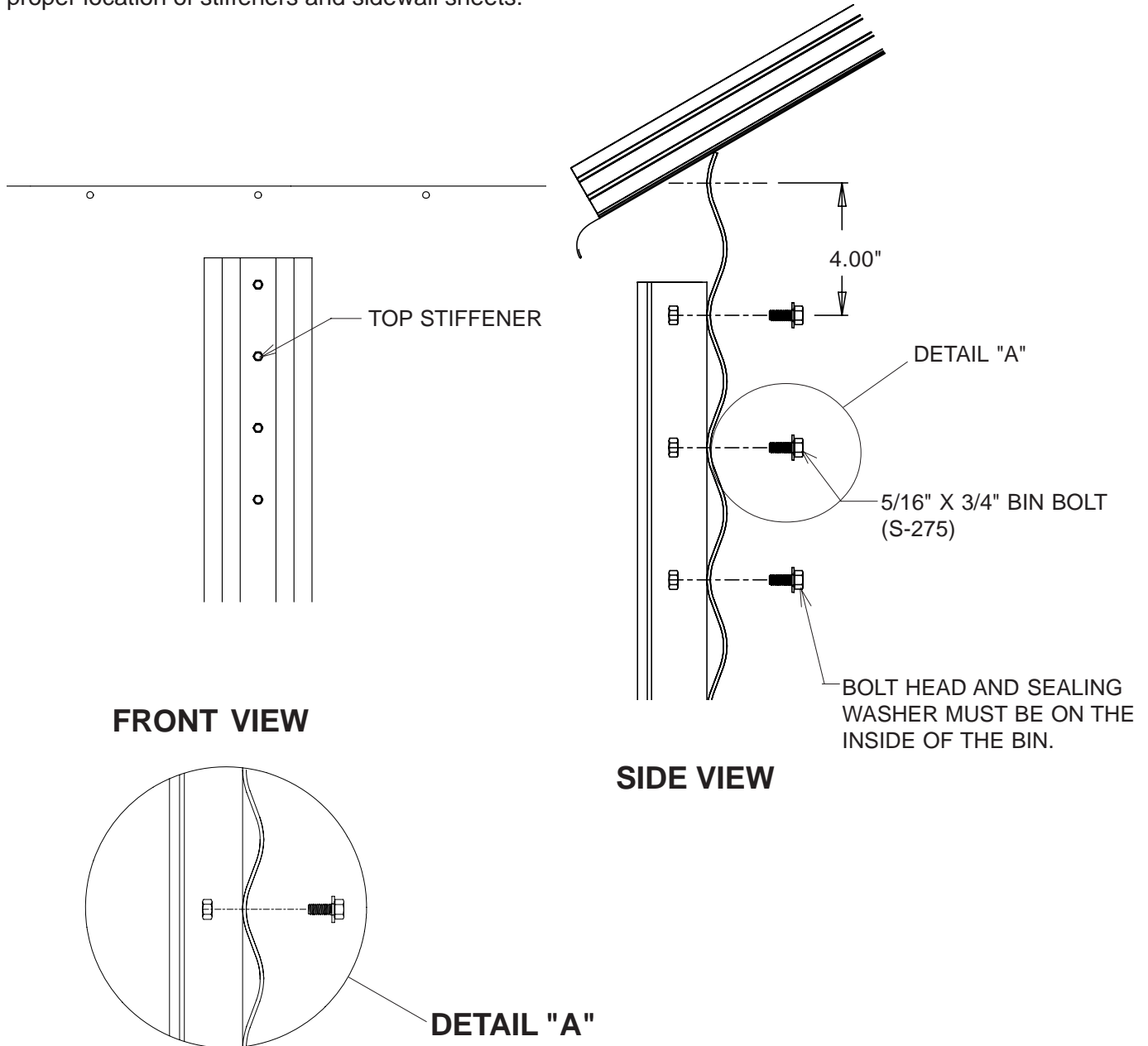

Figure #13

## STIFFENER INSTALLATION & LOCATION

When installing bottom stiffeners, you may find that in some cases the stiffener with base plate attached will not rest on the foundation (due to unlevel concrete, etc.) Shim plates have been furnished and should be used to fill opening between base plate and concrete.

**IMPORTANT:** If shim plates are not used where required, the downward pressure of the stiffeners will not be transferred directly to the foundation, and bin failure could result.

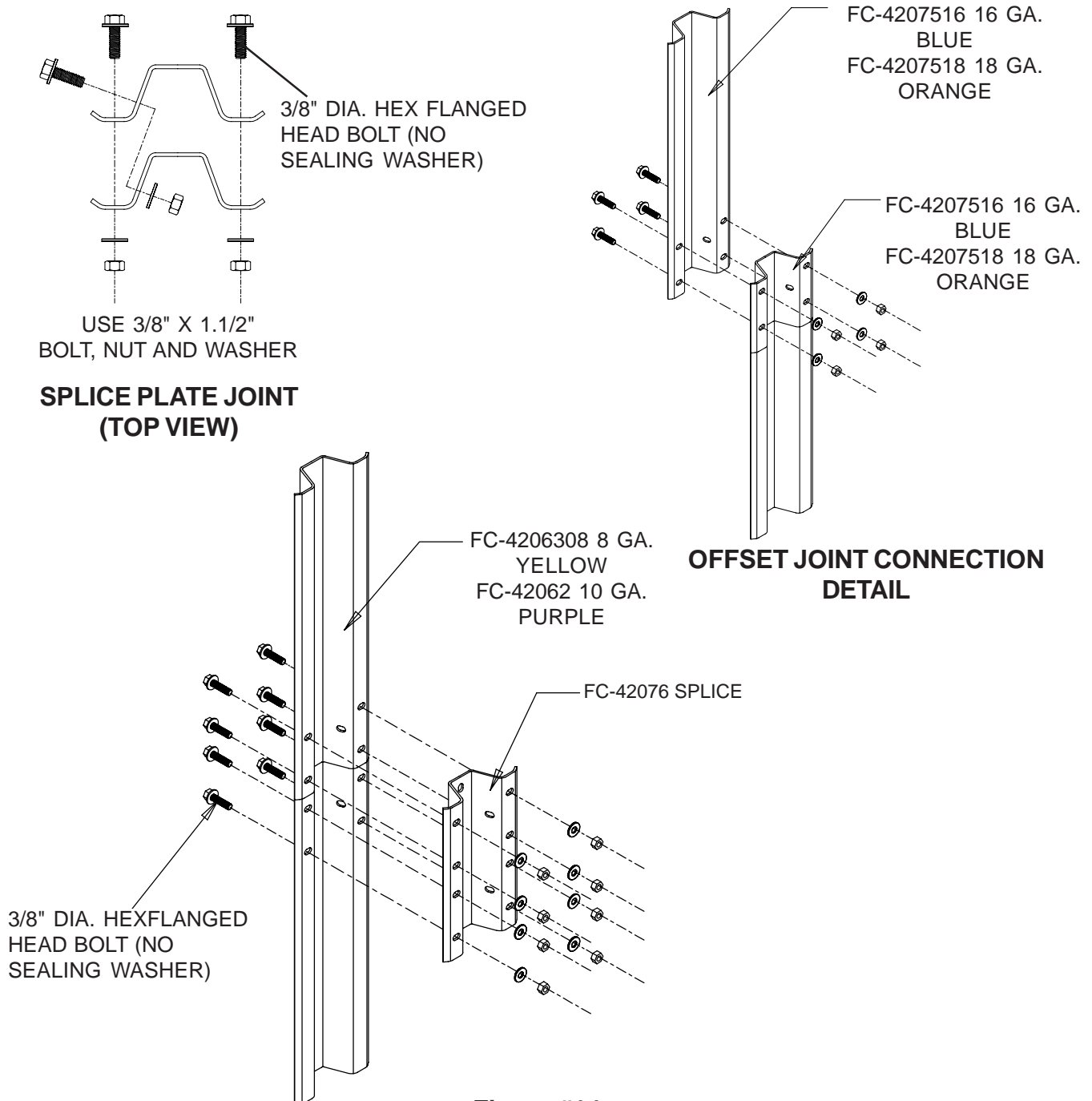

Figure #14

## BOLTING REQUIREMENTS 2 STIFFENERS PER SIDEWALL SHEET

Sidewall Gauge	Horizontal Seam	Vertical Seam	Stiffener To Sidewall	Overlap Seam
17 Thru 20	5/16" x 3/4" [10]	5/16" x 3/4" [42]	5/16" x 3/4" [20]	5/16" x 3/4" [2]

All bolts are standard bin bolts with neoprene washers. For horizontal and vertical seam bolts, the bolt head and neoprene washers are on the outside of the bin.

Note: For the splice plates FC-42076 use 5/16" x 1.1/4" bolts for the stiffener to sidewall connections.

### Standard (17 Gauge Thru 20 Gauge) Sheet Bolting Detail (Viewed from outside of the bin)

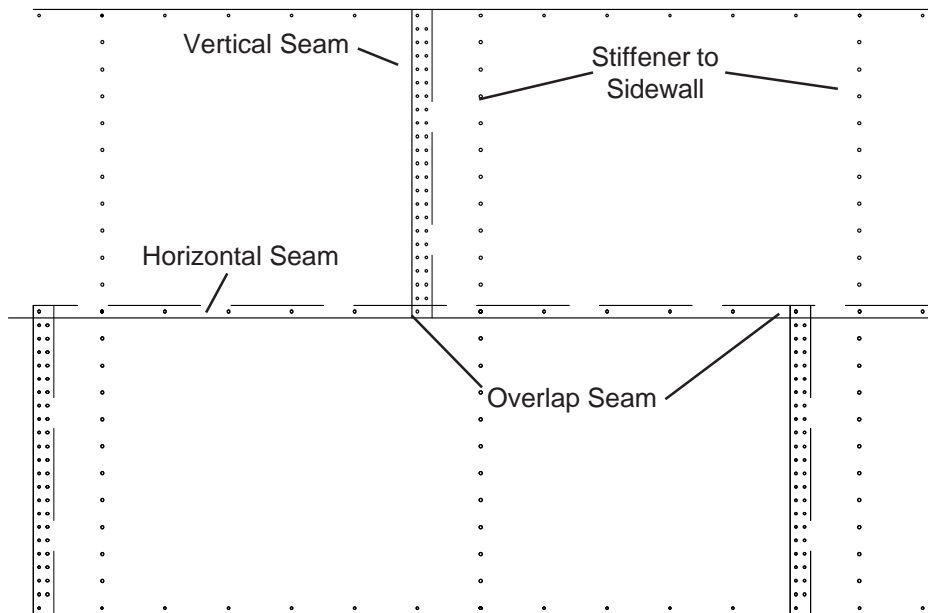

**Figure #15**

---

# STIFFENER & SEAM LOCATIONS

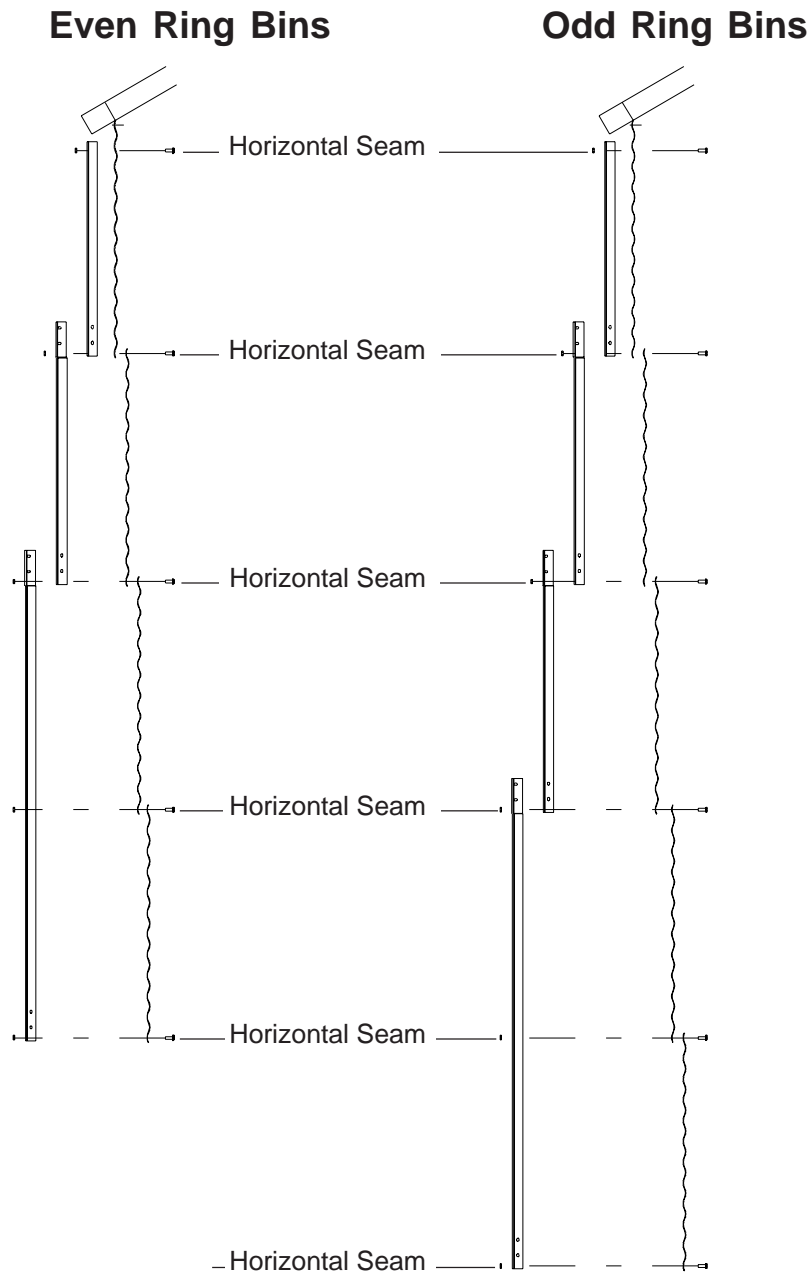

2 stiffeners per sidewall sheet  
Top Dry stiffener starting location -18' to 36'  
4" corrugation stiffener only

**Figure #16**

## SIDEWALL ERECTION INSTRUCTIONS

Before bolting the sidewall sheets together, check that you have the proper gauge steel for the first ring. The higher gauge numbers denote the thinner materials. (For example, 22 gauge material is thinner than 14 gauge.) In erecting most grain bins the thinnest material usually goes on top, therefore the first sidewall ring you assemble will be the top ring of your bin. Check the various gauges of your bin with the Color Code Chart and begin building accordingly  
**REMEMBER.....Assemble the top ring first.**

Once you have selected the proper gauge material, begin assembling all sidewall sheets in the following manner: Standing on the inside the bin, place the left panel to the inside with the right panel to the outside. (See Fig. A-A). **Check to see that the sidewall sheet is "Right Side up"** reference page 21 for details.

**Note: The rope caulking is installed before each sheet is assembled. Apply rope caulking between the last vertical row of bolts and edge of outside sheet. There is sufficient caulking for all vertical seams on storage and drying bins. Wipe sheet clean where caulking is to be applied.**

Using correct size bin bolts throughout, begin assembling sidewall sheets end to end (overlapping the same way throughout) until the ring is completed. All body sheet bolts are to be installed with the bolt head and its neoprene washer to the outside, and the nut on the inside. Do not tighten bolts until all sheets are assembled and form a complete ring. Attach lifting brackets to stiffener bolt holes. These straps, coupled to the jacks will enable you to later elevate your bin. Now tighten the bolts in sequence, starting from the center and working to the edge in both directions. This permits the sidewall sheets to draw-up evenly. Complete one ring and stop. You are now ready to assemble the roof. Refer to the roof erection manual for roof assembly instructions located in roof hardware box.

GAUGE	COLOR CODE
22	WHITE
20	RED
19	BLACK/YELLOW
18	ORANGE
17	PINK/LIGHT BLUE
16	BLUE
15	BROWN/RED
14	GREEN
13	YELLOW/BLUE
12	BLACK
11	PINK
10	LIGHT BLUE
9	BLUE/ORANGE
8	YELLOW

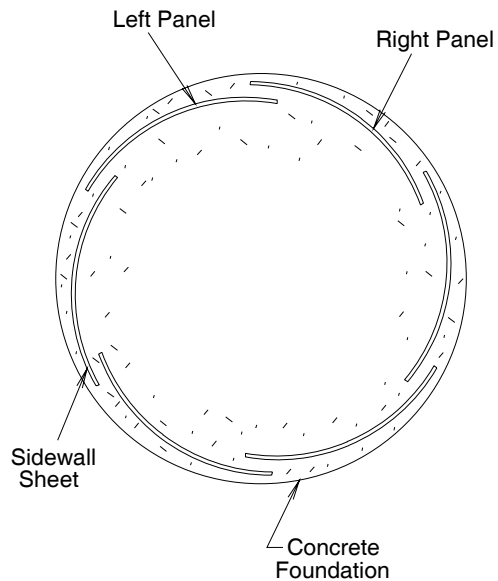

**FIG. A-A  
CAULKING DETAIL**

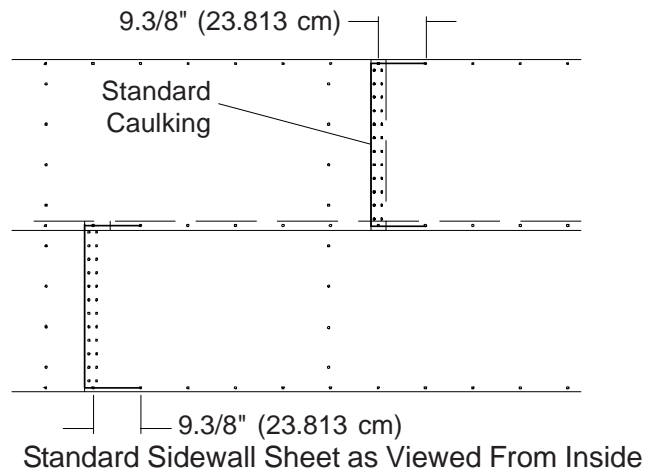

**Figure #17**

---

## SIDEWALL CONSTRUCTION INSTRUCTIONS

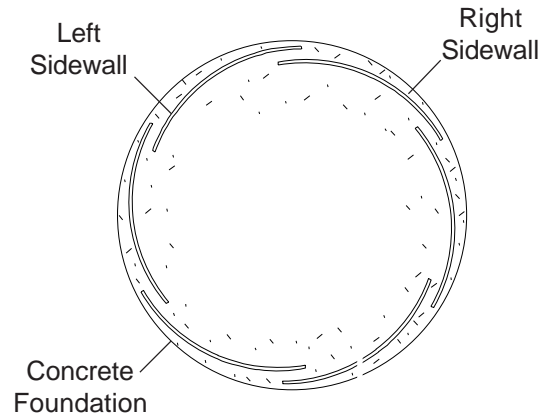

**Figure #18**

Using correct size bin bolts throughout, begin assembling sidewall sheets end to end (overlapping the same way throughout) until the ring is complete. All body sheet bolts are to be installed with the bolt head and its neoprene washer to the outside and the nut on the inside. Do not tighten bolts until all sheets are assembled and form a complete ring. Tighten the bolts in sequence, starting from the center and work to the edge in both directions. This permits the sidewall sheets to draw-up evenly.

After assembling the **second ring**, lift the top ring sheets in place, add top stiffeners, build the Top Dry floor, then the roof.

**Note:** The sidewall sheets used for the **top ring** are punched to accommodate the eave flashing bolts.

**Note:** The fan entrance sheet and access door are located in the second ring. Attach the top stiffeners, leaving out the (7) bolts indicated in Figure #19 at each stiffener location. Install the flashing bolts from the outside.

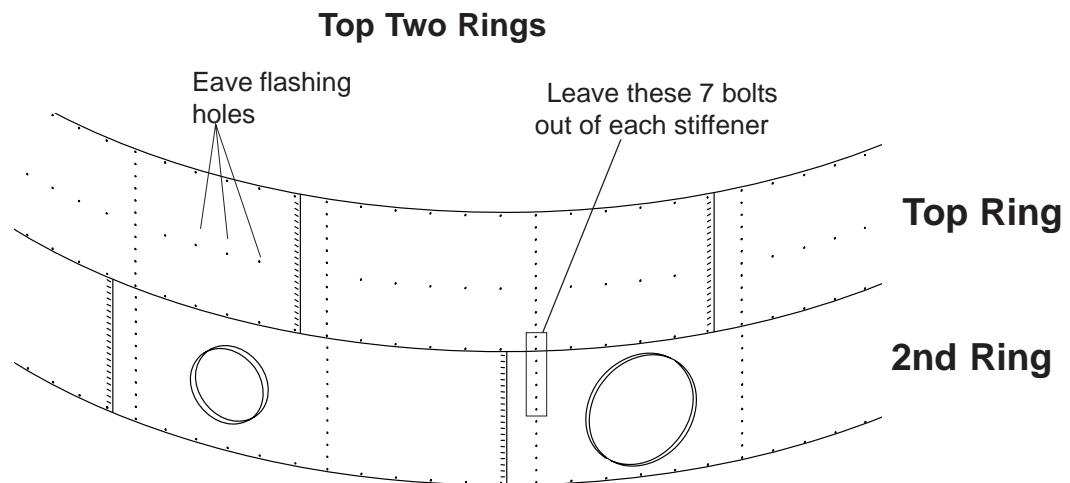
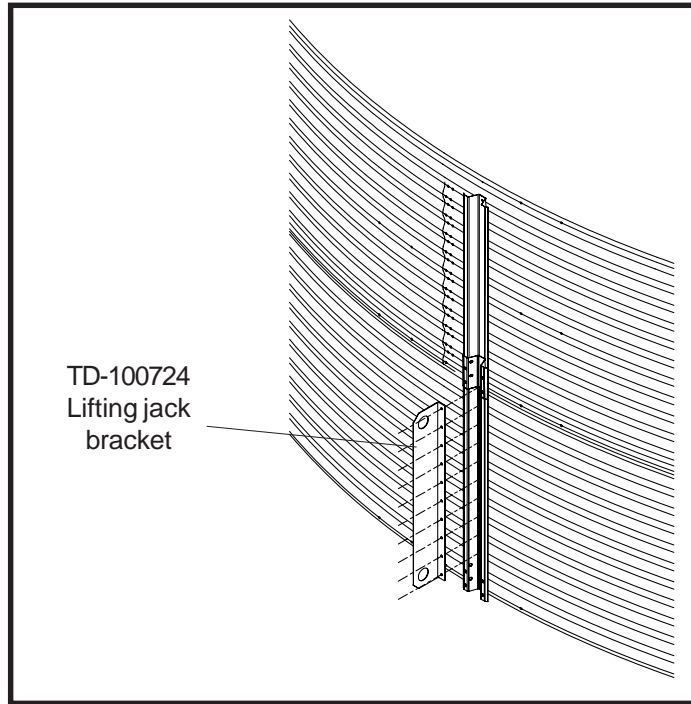

**Figure #19**

---

## LIFTING JACKS & BRACKETS

**NOTE:** The number of lifting jacks required is best determined by personal experience. Factors such as bin size, soil compaction, wind velocity, jack design, etc., are all to be considered when deciding how many to use. If in doubt, use one jack on every other stiffener. GSI recommends heavy duty jacks rated at 6,000 lbs. or more.



**Figure #20**

---

## LIFTING JACK USAGE

Give some thought before starting your bin on location of door and other accessories. Proper placement of lifting jacks in relationship to anchor bolts could make a difference on odd or even ring bins. Walk-thru door is centered between two stiffener anchor bolts. The sidewall sheets are also staggered 1/2 from end to end.

### WARNING!!

The number of lifting jacks required is best determined by personal experience. Factors such as bin size, soil compaction, wind velocity, jack design, etc. are all to be considered when deciding how many to use. If in doubt, use one jack on every vertical seam. Be sure to use Heavy Duty jacks for commercial installation.

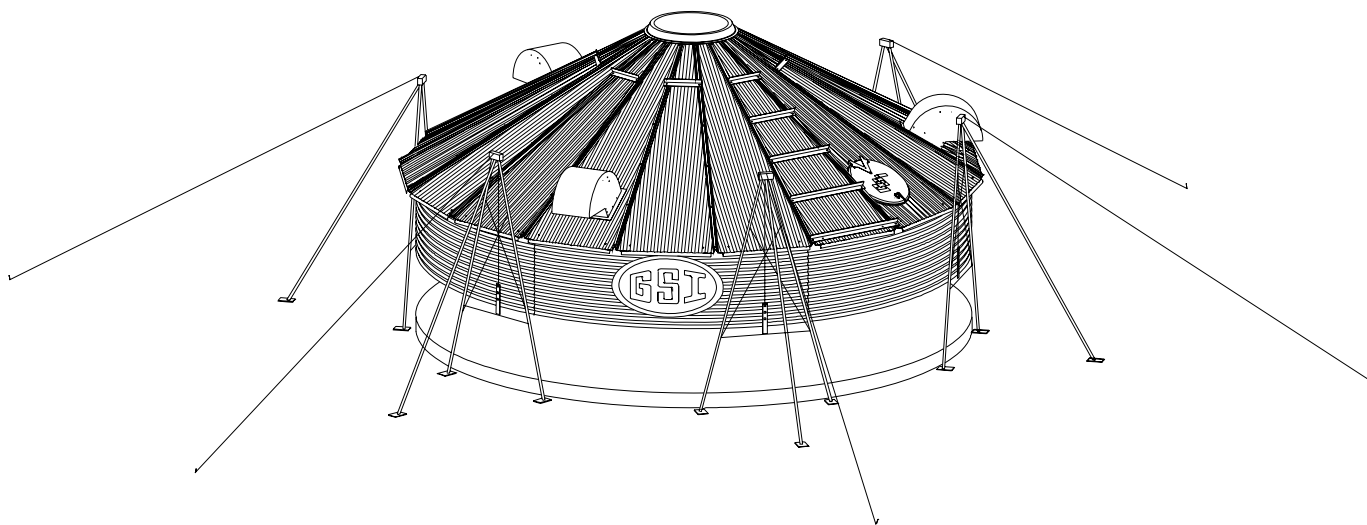

**Figure #21**

Lifting brackets should be attached to the stiffeners. Normally you will need to attach to at least 4 bolts per stiffener. Anchor all jacks securely with metal stakes and cable. Now raise the bin just high enough to assemble the next ring. When lifting your bin, crank all jacks at an equal rate. This will prevent bowing previously assembled rings and make for easier hole alignment. To the inside of the first ring, bolt the next ring. Be sure to stagger the sheets and select the proper gauge material. Lower the bin on the foundation after assembling and tightening bolts on the new ring or rings. When installing Duct Work for the drying fans be sure to install it as you go up with the bin letting the duct set on the foundation before the bolts are tightened to assure proper alignment. Now rebolt the lifting straps to the lowest ring in place thus far. Continue ring additions until you are ready for door installation. You may want to leave sheets loose to make the attachment of the stiffeners easier.

### NOTES:

- Add inside and outside ladders to bin walls as you continue to raise the bin.



## STIFFENER TO C-CHANNEL BRACKET INSTALLATION

Install the stiffeners on the outside of the bin (as shown below) and the wall brackets on the inside of the bin. The wall brackets are to be positioned with the bracket's top hole matching the first hole up from the horizontal seam (not counting the horizontal seam). Bracket to sidewall connection using a 3/8" x 1.1/2" bolt (S-2086), head outside, with a neoprene washer (S-3558) against the wall on the inside.

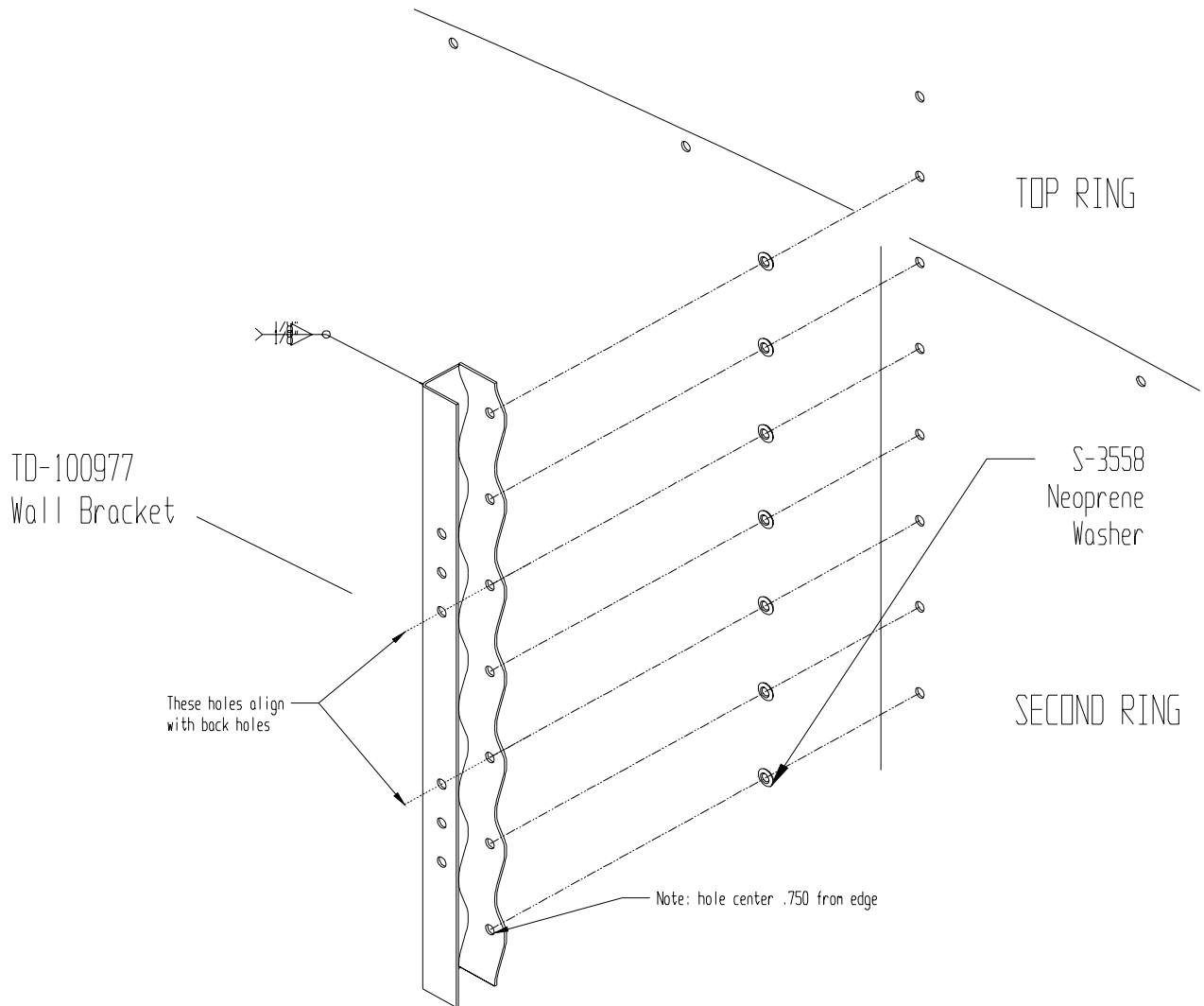

Figure #22

## "C" CHANNEL INSTALLATION

Fasten the rolled "C" eave members to the wall brackets in the upper 2 holes of the top set of three (3) holes leaving the bolts loose.

Install the splice plates at the rolled "C" eave member seams using 3/8" x 1" flanged hex bolts and nuts. Install bolts as shown below. Tighten all bolts.

### "C" Channel Attachment.

TD-100772  
Eave "C" Channel

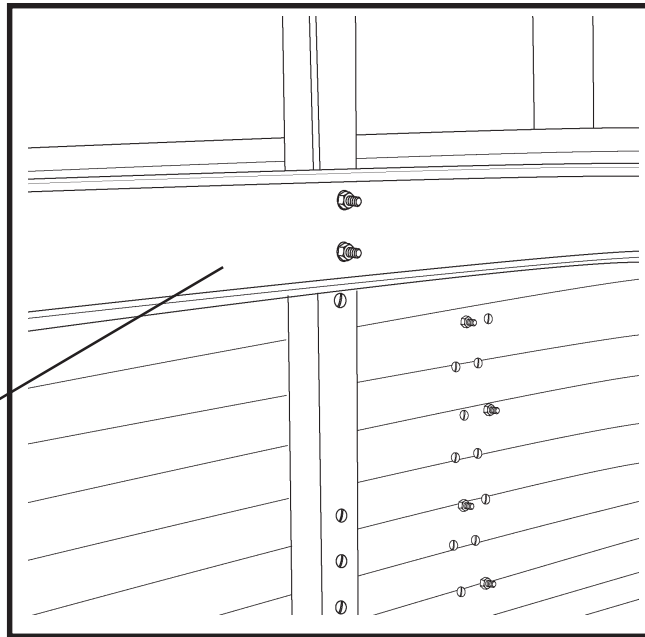

**Figure #23**

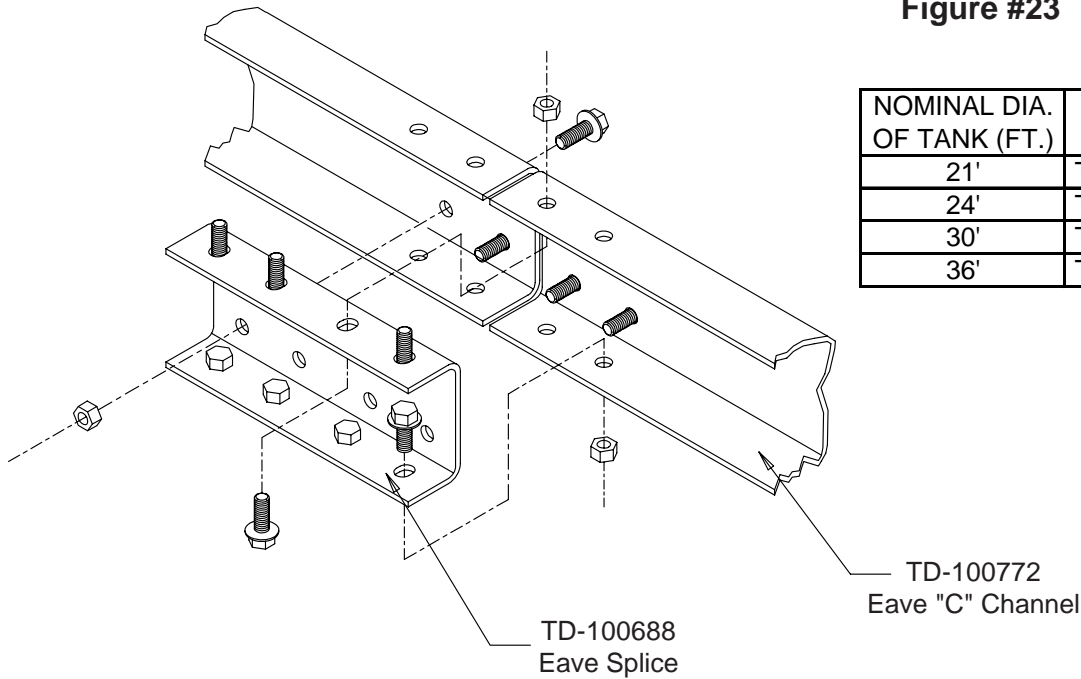

NOMINAL DIA. OF TANK (FT.)	PART "A" NUMBER
21'	TD-100772
24'	TD-100678
30'	TD-100643
36'	TD-100731

**Figure #24**

# CENTER COLLAR ASSEMBLY

Add channel braces and brace plates to center collar as shown using 3/8" x 1" bolts and nuts. (Do not attach cross channel until floor is done if using a jack on center collar.)

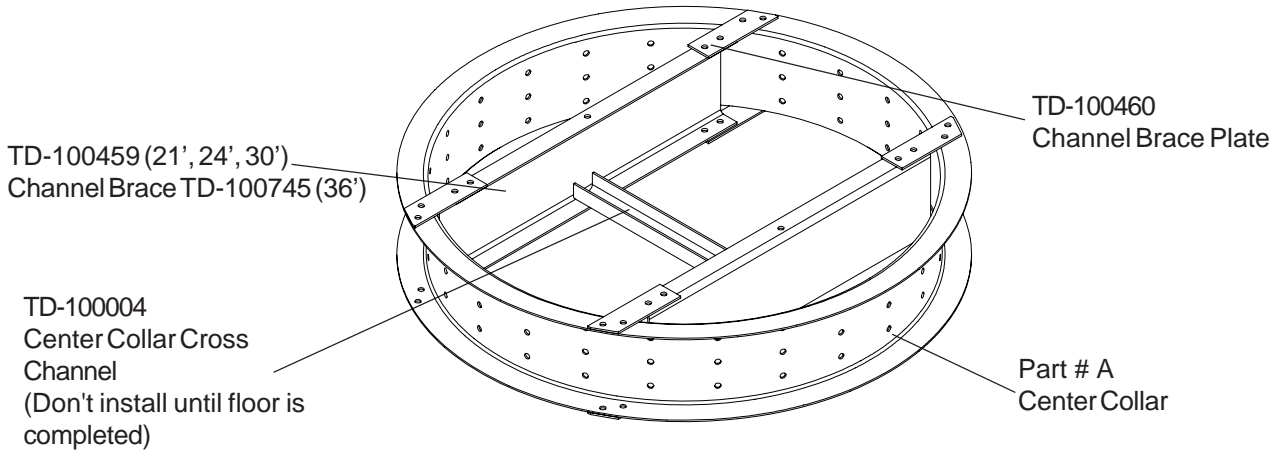
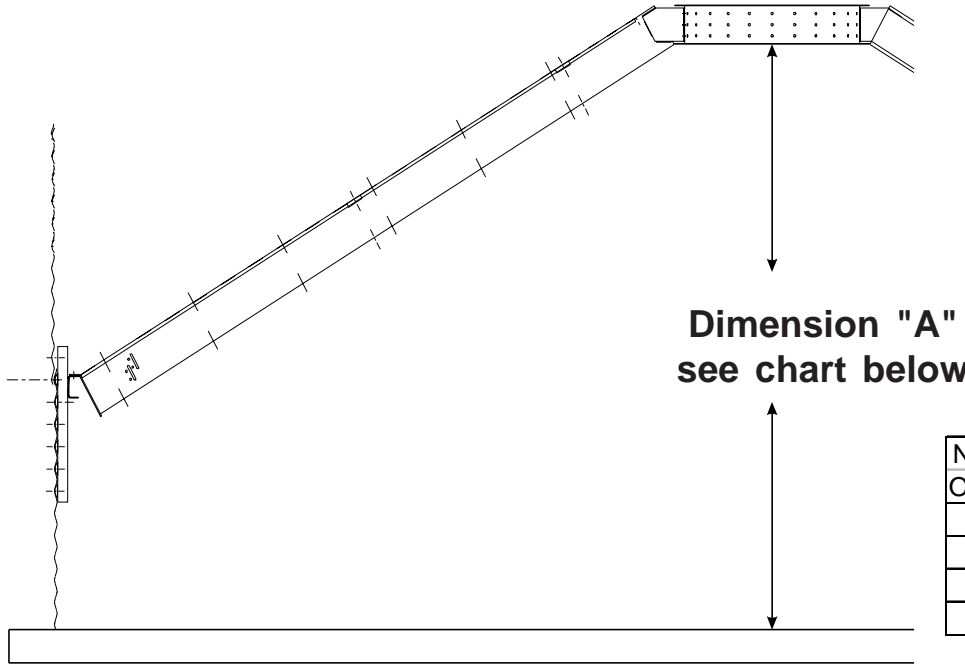

Figure #25

NOMINAL DIA. OF TANK (FT.)	PART "A" NUMBER
21'	TD-100631
24'	TD-100632
30'	TD-100634
36'	TD-100730

Position the center collar at the center of the bin and raise it to the required height per diameter of tank. Height is measured from the bottom of the center collar to the concrete.



Dimension "A"  
see chart below

NOMINAL DIA. OF TANK (FT.)	DIMENSION "A"
21'	8'-0.1/2"
24'	8'-9.1/2"
30'	10'-5.3/16"
36'	11'-8.3/4"

Figure #26

## RAFTER INSTALLATION & FLOOR SUPPORT ANGLE ATTACHMENT

When installing the rafters, set the lower clip end on the "C" eave member. Leave the bolts to the center collar and the eave member loose until all rafters are in place. Use 3/8" x 1" hex bolts and nuts to connect the center collar and eave member to three (3) rafters at 90 degrees to each other. Two of the first three (3) rafters should all face the same direction and be from bundle of 11 rafters. Every other rafter should alternate direction. **IMPORTANT:** There are left & right rafters. Be sure to alternate left, right, left, right, etc.. The floor sheet support purlins can now be installed using 5/16" x 3/4" bin bolts. There are three (3) different lengths of purlins to fit between the rafters. Insert the straight tab of the purlin through the upper slot in the left hand rafter when looking toward the bottom of the rafters. Bolt the bent end of the purlin to the right hand rafter in the upper two (2) holes. After inserting the next purlin tab, bolt the first purlin tab to the second purlin. Continue around the bin alternating lengths as the rafter facings did. Tighten all bolts.

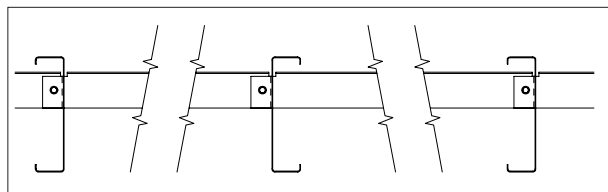

Looking toward the sidewall

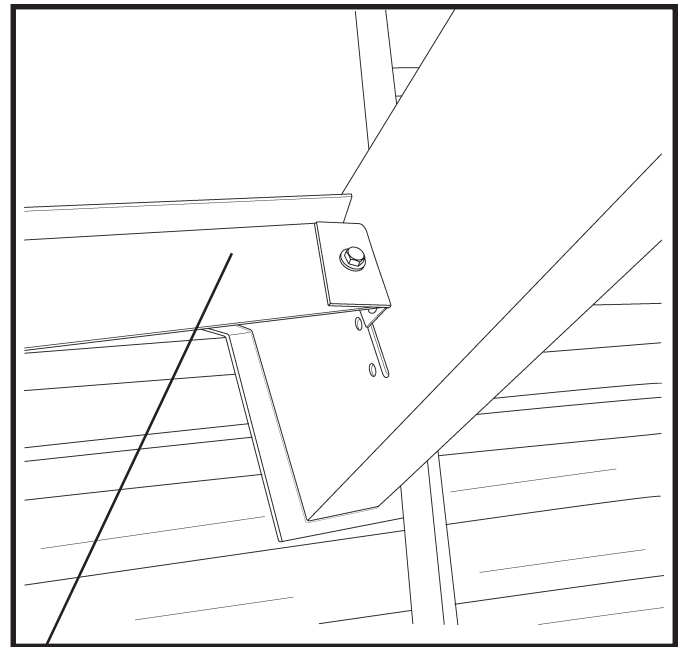

**Figure #27**

Floor Support Angle Assembly

NOMINAL DIA. OF TANK (FT.)	LONG SUPPORT	SHORT SUPPORT
21'	TD-100777	TD-100778
24'	TD-100720	TD-100721
30'	TD-100650	TD-100651
36'	TD-100740	TD-100741

---

## 21' SPECIAL ANGLE PURLIN ASSEMBLY

Where two rafters face the same direction use 5/16" x 3/4" bin bolts and nuts with the three bent edges facing toward the sidewall, the longest edge on top.

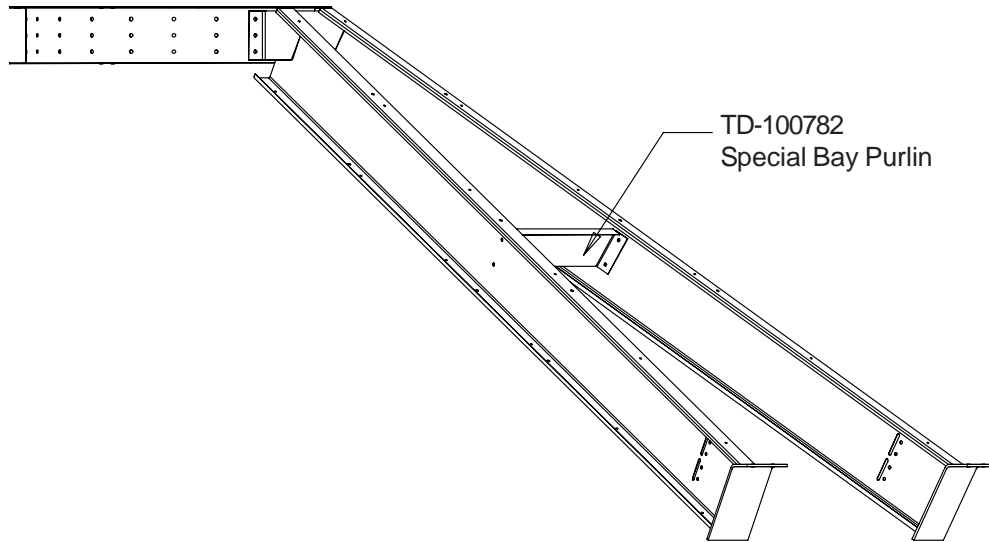

Figure #28

## 21' INTERMEDIATE PURLIN

Bolt purlins to rafters (as shown in the photo) in the 4th hole counting up from the sidewall.

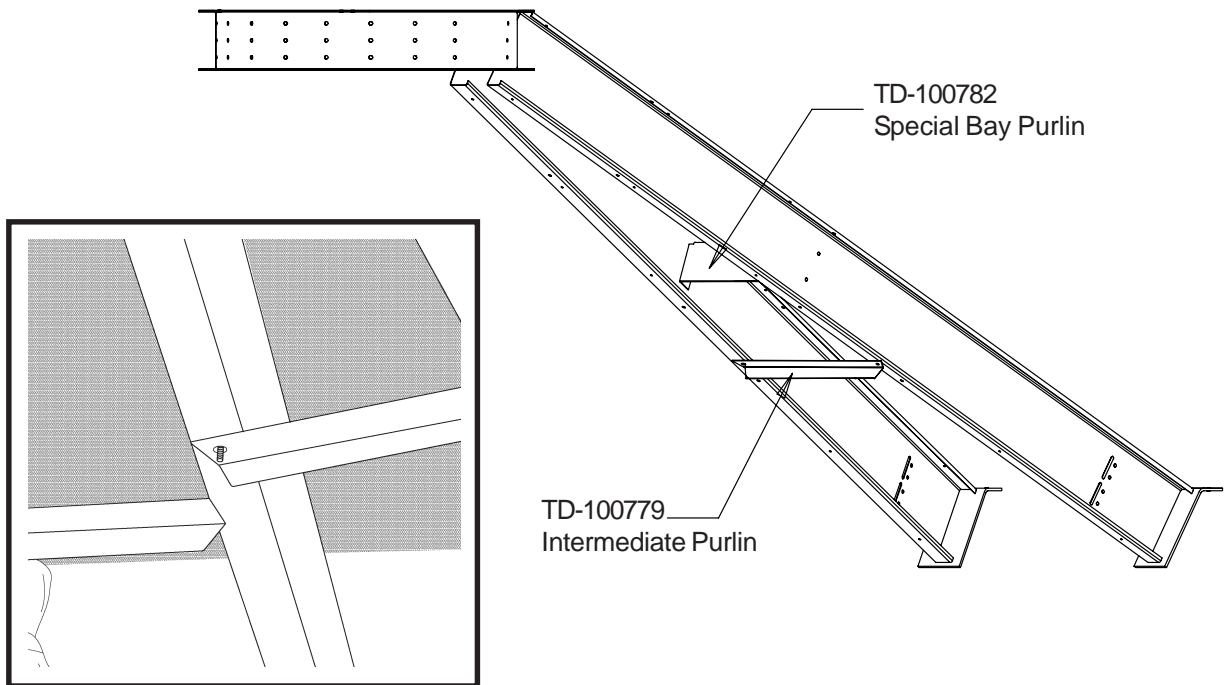
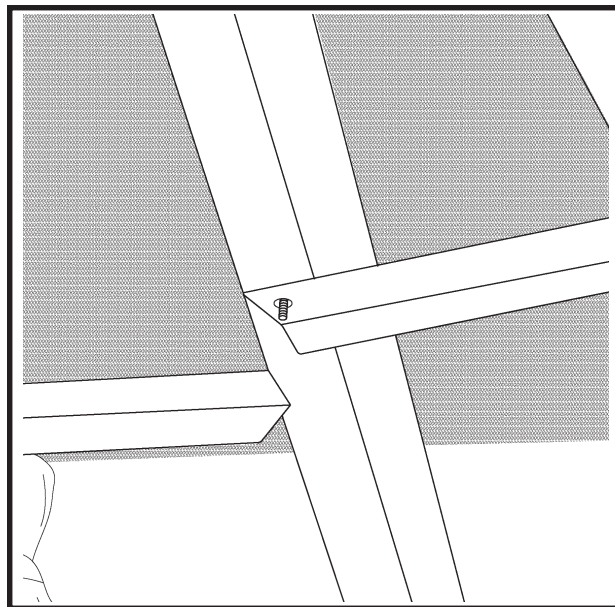
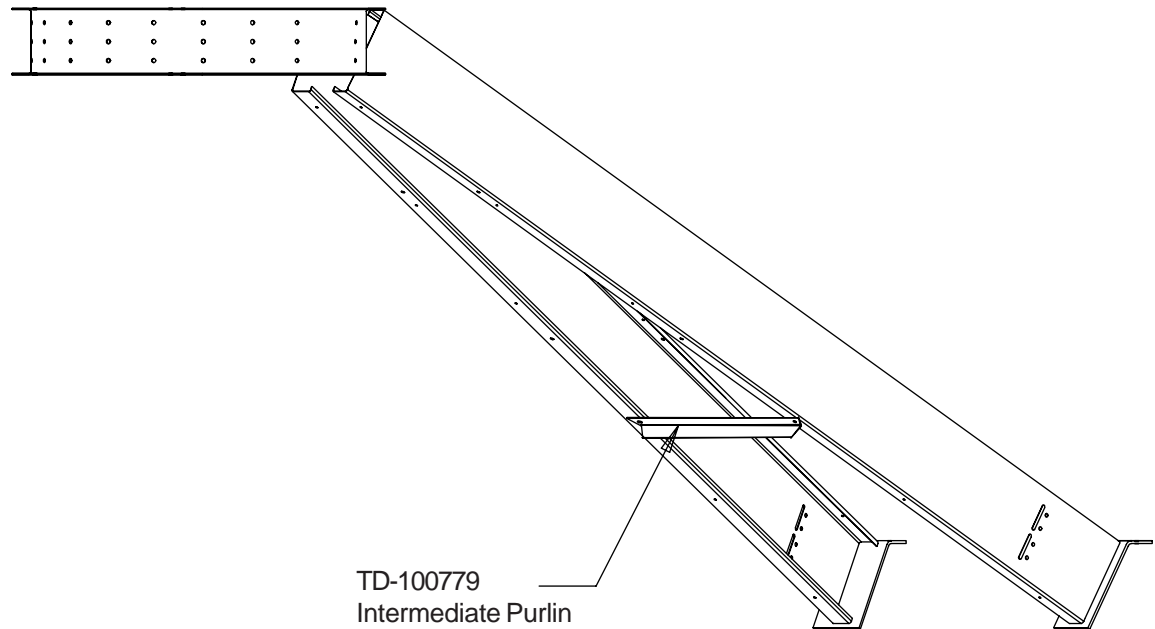

Figure #29

---

## 24' INTERMEDIATE PURLIN

Counting up from the lower end of the rafter, on the underneath side, the angle purlins bolt in the 3rd hole using 5/16" x 3/4" bin bolts. The angle is to be bolted to the underneath side of the rafters, joining rafter to rafter, with the angle interior angle facing the center of the bin. (as shown in the photo). Tighten all bolts.

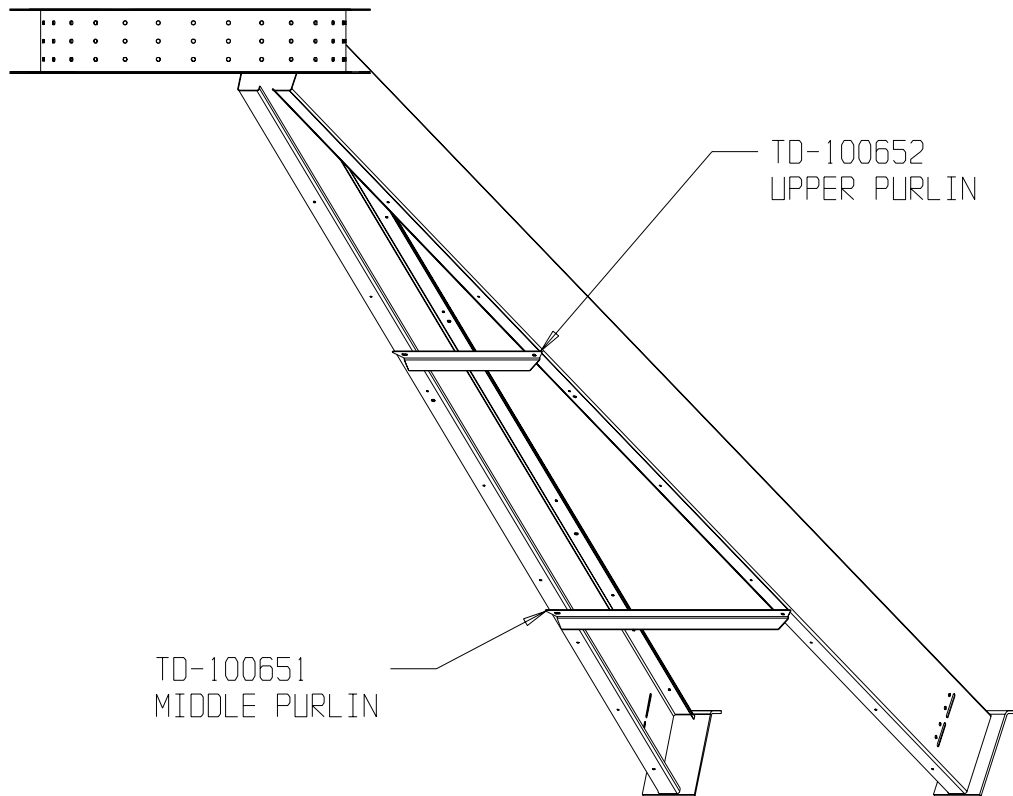

**Figure #30**

The angle is to be bolted on the underneath side of the rafters, joining rafter to rafter, with the angles interior angle facing the center of the bin.

## 30' INTERMEDIATE PURLIN

The upper purlins are bolted using 5/16" x 1-1/4" bolts in the 9th hole counting up from the sidewall. The middle pulins are bolted in the 4th hole counting up from the sidewall. Bolt purlins to rafters with interior angle facing the center of the bin as shown in the photo.



The angle is to be bolted on the underneath side of the rafters, joining rafter to rafter, with the angles interior angle facing the center of the bin.

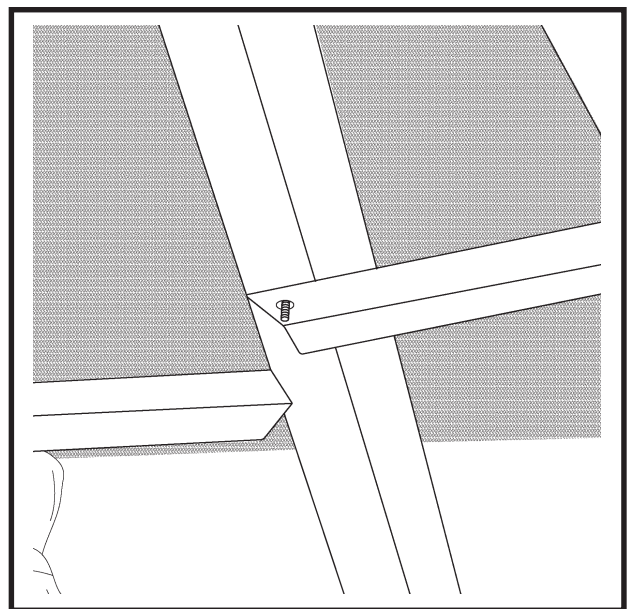
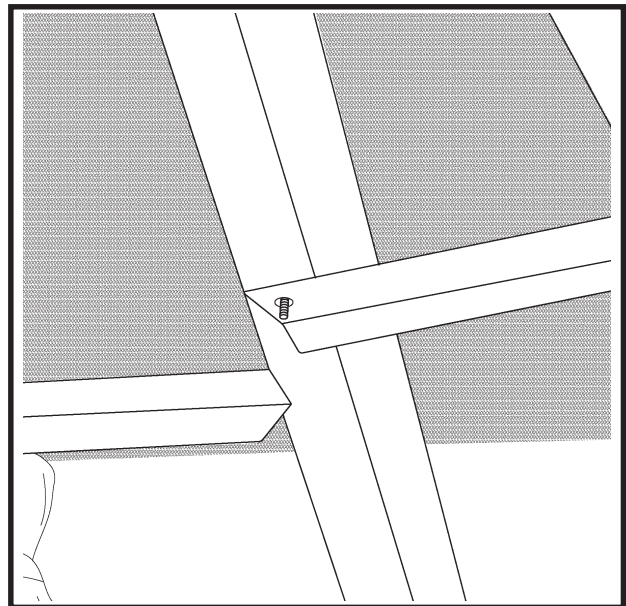
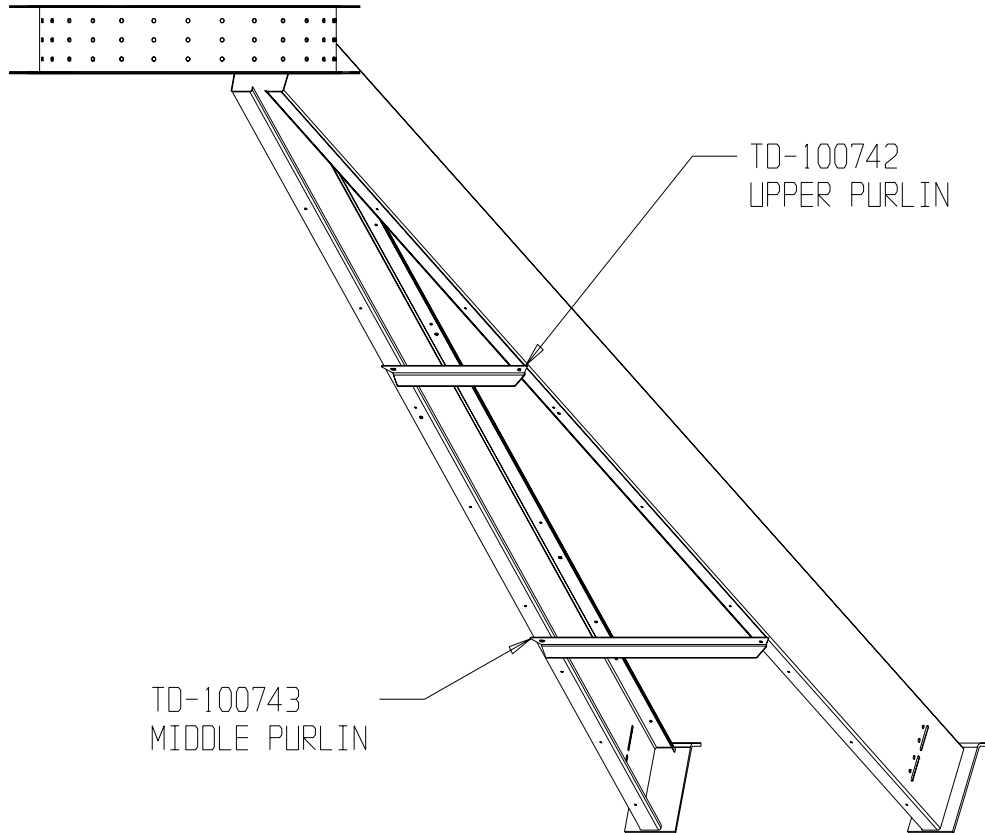

**Figure #31**

---

## 36' INTERMEDIATE PURLIN

The upper purlins are bolted using 5/16" x 1-1/4" bolts in the 9th hole counting up from the sidewall. The middle pulins are bolted in the 4th hole counting up from the sidewall. Bolt purlins to rafters with interior angle facing the center of the bin as shown in the photo.



The angle is to be bolted on the underneath side of the rafters, joining rafter to rafter, with the angles interior angle facing the center of the bin.

**Figure #32**



## DUMP HOPPER INSTALLATION

Pre-assemble the dump hoppers, dump brackets, and flashing angles to the floor sheets. Place a dump hopper under the floor sheet and align it with the pre-punched large hole. Place a flashing angle on top of the sheet across the outer edge of the hopper entrance with the interior of the angle facing the sidewall. Screw down through the angle, sheet, and hopper with 5/16" x 3/4" self-tapping screws.

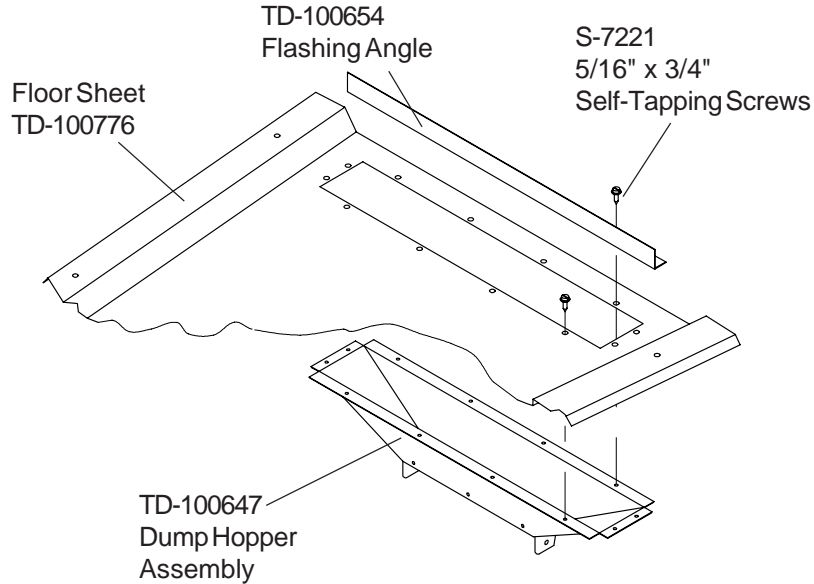

Figure #33

## FLOOR SHEET INSTALLATION

Now the assembled sheets can be placed over the rafter framework. As the sheets are placed and overlapped they are to be screwed down to the rafters using 5/16" x 3/4" self-tapping screws, leaving the third and eighth holes empty.

NOMINAL DIA. OF TANK (FT.)	NUMBER OF HOLES TO LEAVE EMPTY
21'	3RD, AND 8TH HOLES
24'	3RD, AND 8TH HOLES
30'	4TH, 7TH, AND 10TH HOLES
36'	3RD, 6TH, 10TH, AND 12TH HOLES

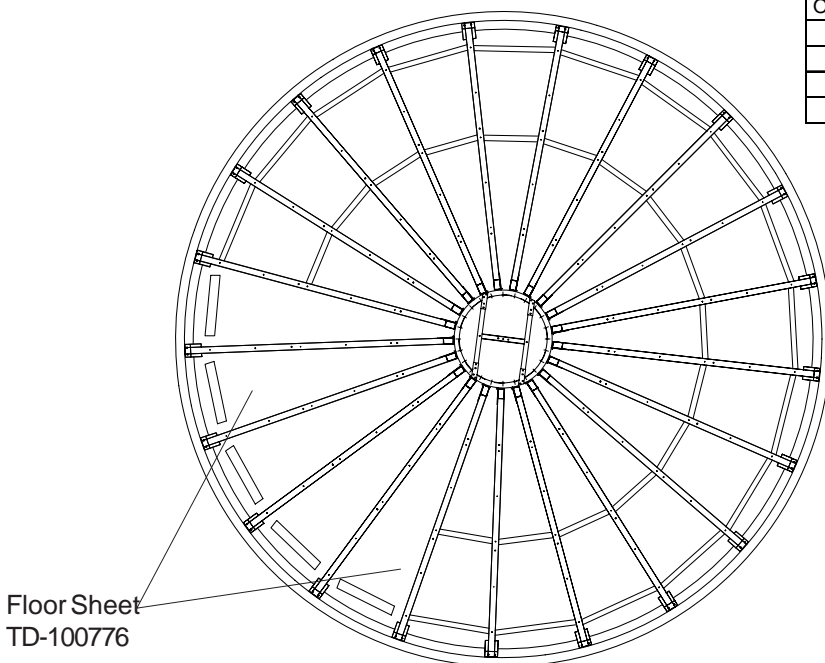

Figure #34

## 21' & 24' LEVELING BAND POST INSTALLATION

Install the leveling band posts on the floor as shown.

**21 FT.** The third and eighth holes in the floor sheet indicate the location of the leveling band posts. Attach posts with 5/16" x 1.1/4" bin bolts (S-277). The third hole from the bottom of the sheet, there will be 7 posts (1 every third sheet). In the eighth hole there will be 5 posts (1 every fourth sheet except the last will cover 5 sheets ). After all of the posts have been installed fill the unused holes with 5/16" x 1.1/4" bin bolts.

**24 FT.** The fourth and eighth holes in the floor sheet indicate the location of the leveling band posts. Attach posts with 5/16" x 1.1/4" bin bolts (S-277). The third hole from the bottom of the sheet, there will be 8 posts (1 every third sheet). In the eighth hole there will be 4 posts (1 every sixth sheet). After all of the posts have been installed fill the unused holes with 5/16" x 1.1/4" bin bolts.

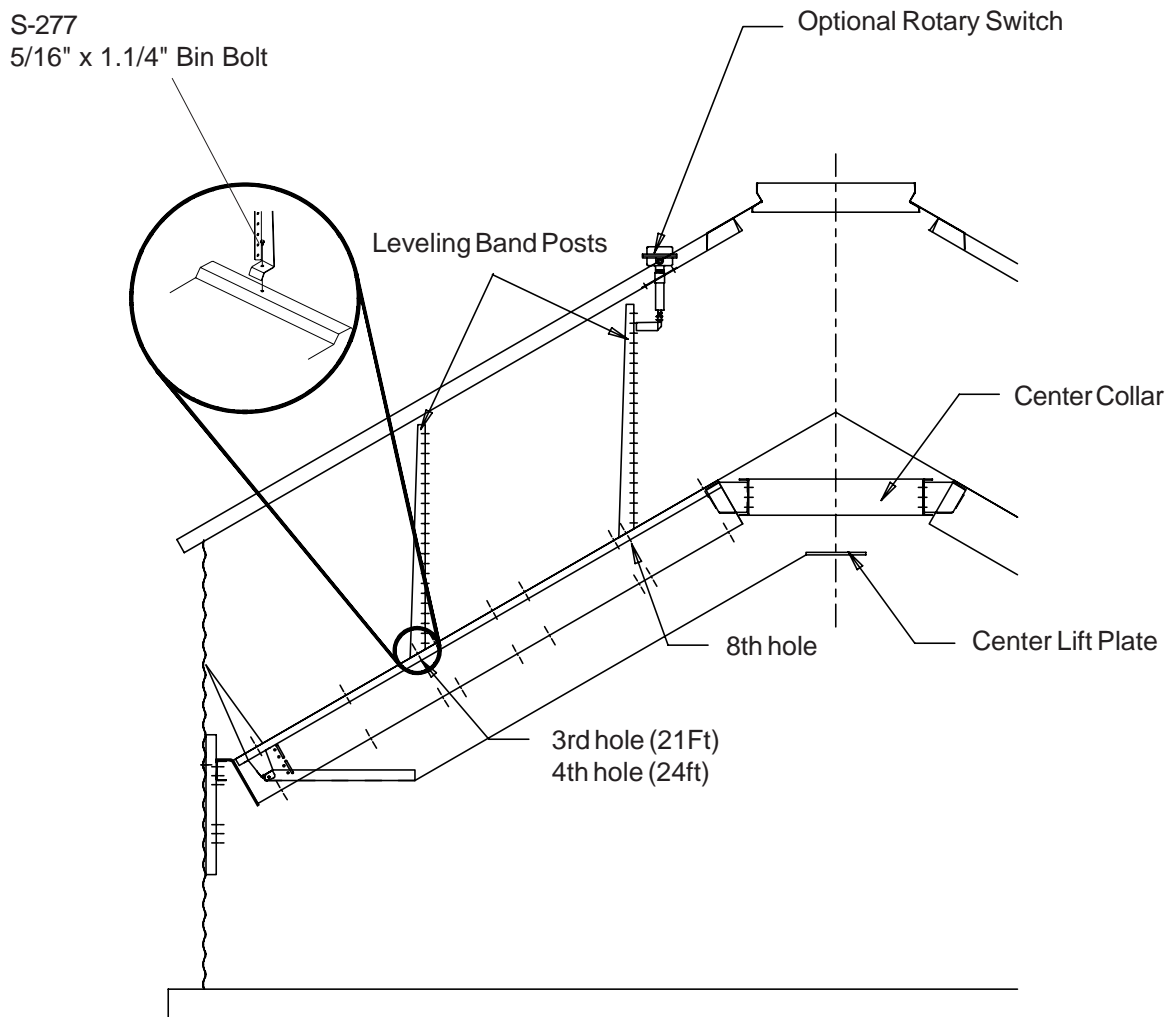

Figure #35

---

## 30' LEVELING BAND POST INSTALLATION

Install the leveling band posts on the floor as shown in Diagram below.

The 4th, 7th and 10th holes in the floor sheets indicate the location of the leveling band posts. Attach with 5/16" x 1.1/4" bin bolts (S-277). In the 4th & 7th hole there will be 10 posts (1 at every 3rd sheet). In the 10th hole there will be 6 posts 1 every 5th.

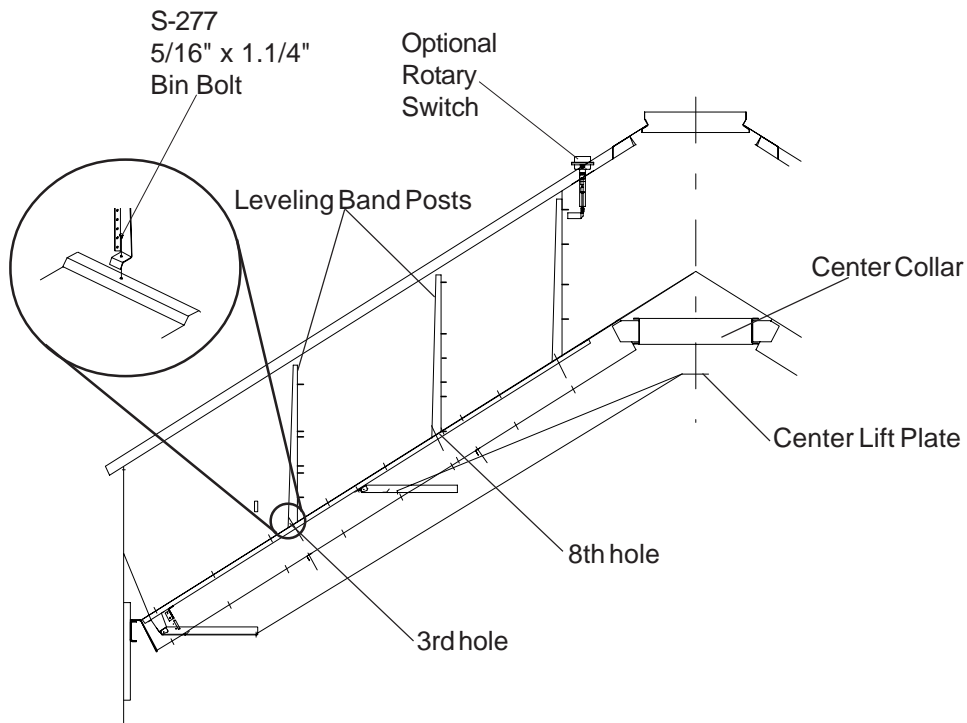

**Figure #36**

---

## 36' LEVELING BAND POST INSTALLATION

Install the leveling band posts on the floor as shown in Diagram.

The 3rd, 6th, 10th, and 12th holes in the floor sheets indicate the location of the leveling band posts. Attach with 5/16" x 1.1/4" bin bolts (S-277). In the 3rd hole from the bottom of the floor sheets there will be 18 posts (one in every other sheet). In the 6th & 10th hole there will be 12 posts (1 at every 3rd sheet). In the 12th hole there will be 6 posts ( 1 every 6th sheet ).

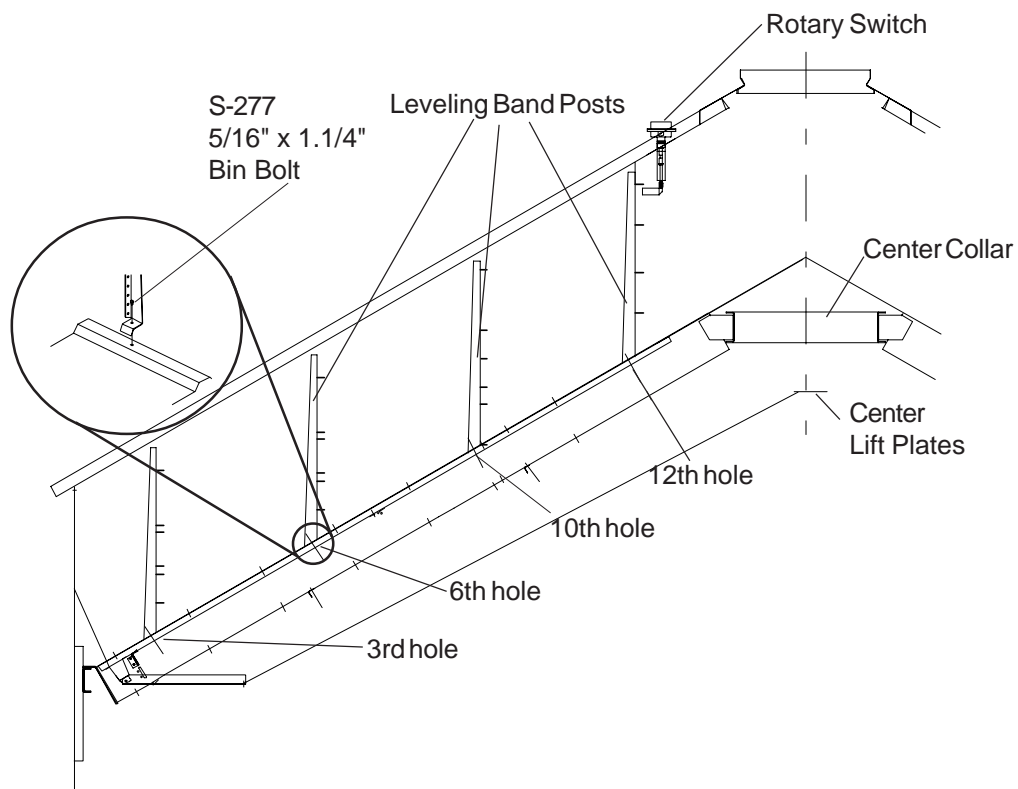

**Figure #37**

## FLASHING BOLT INSTALLATION

Install the eave flashing bolts (5/16" x 1.1/4") through the sidewall and tighten first nut. **Note at the vertical sidewall seams, one bolt is turned around to avoid interference with eave flashing (refer to Figure #38).**

Left bolt on the each vertical sidewall seam level with the eave flashing bolts (as viewed from inside the bin) is to be installed bolt in, nut out, as shown in the photo to the right.

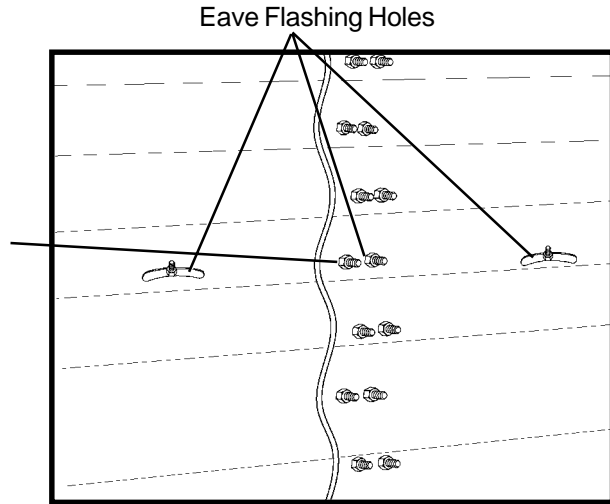
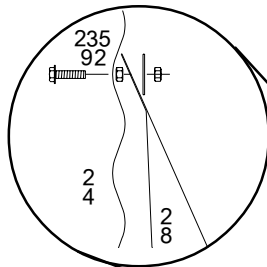

Figure #38

## EAVE FLASHING INSTALLATION

Install the eave flashing centered on the floor sheet (1 per) with the bent edge towards the sidewall install a fender washer (S-3671) and nut. Screw the flashing to the flashing angle at the dump hopper opening with (5) #10 self-drilling (S-280) screws and screw the flashing pieces together where they overlap with (3) #10 self drilling (S-280) screws.



#10 Self-Drilling Screws (S-280)

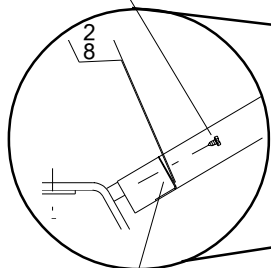

Floor Flashing Angle (TD-100654)

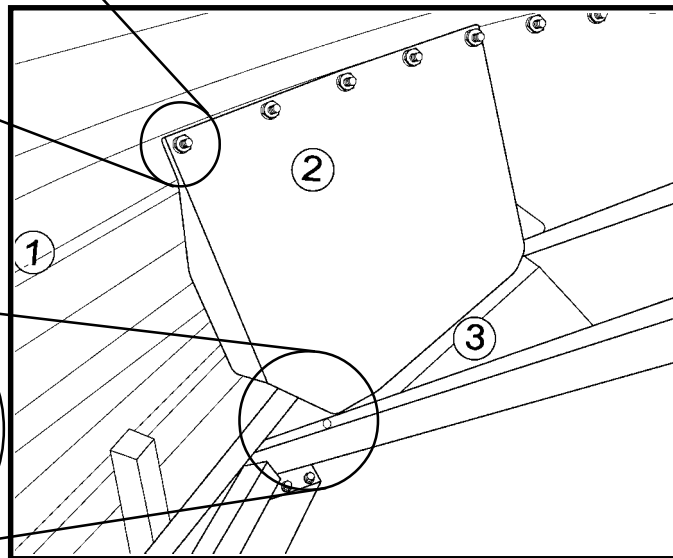
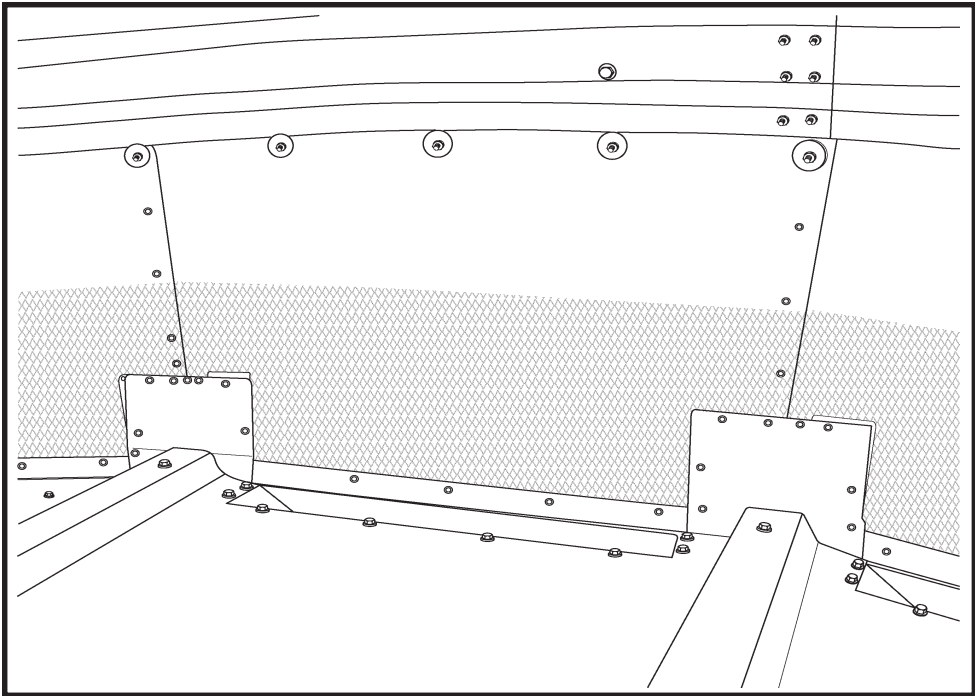

Figure #39

### Flashing Attachment.

- 1) Sidewall,
  - 2) Flashing TD-100648,
  - 3) Floor sheet,
  - 4) 5/16" x 1.1/4" bin bolt.
- Note that there is a nut in between the sidewall sheet and the flashing sheet.

# EAVE FLASHING INSTALLATION



## EAVE FLASHING SPLICE

The flashing splice pieces can now be attached to the eave flashing to seal around the rib of the floor sheet as shown with (S-280) #10 self-drilling screws.

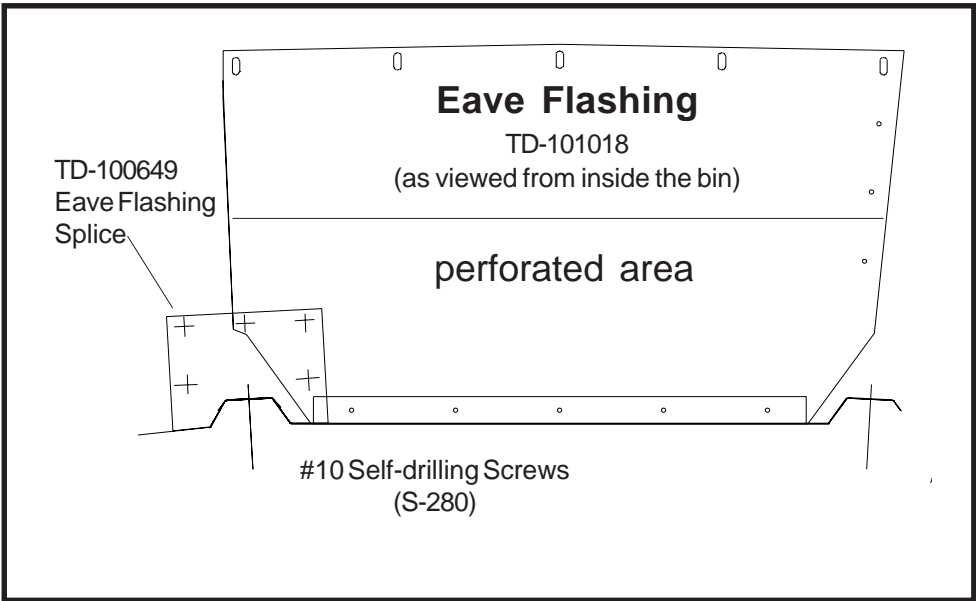
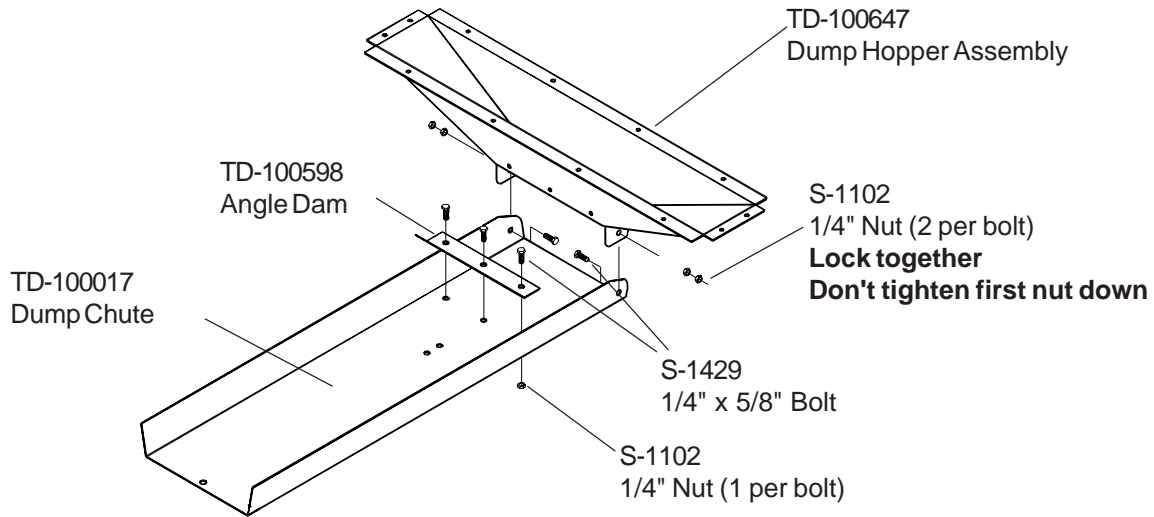

Figure #40

## OUTER DUMP CHUTES

Bolt a TD-100598 angle dam to each dump chute using (3) 1/4" x 5/8" bolts and nuts, as shown below. Use 1/4" x 5/8" bolts and double nuts to fasten dump chutes to hopper. **Do not tighten first nut down!** Lock second nut to first nut and **make sure chutes raise and lower FREELY!**



## INTERMEDIATE DUMP CHUTES

Install a 1/4" nut up each leg of (S-4748) 1/4" u-bolt. Position as shown on each intermediate dump chute and fasten with 1/4" nuts. This u-bolt is where intermediate dump chains attach.

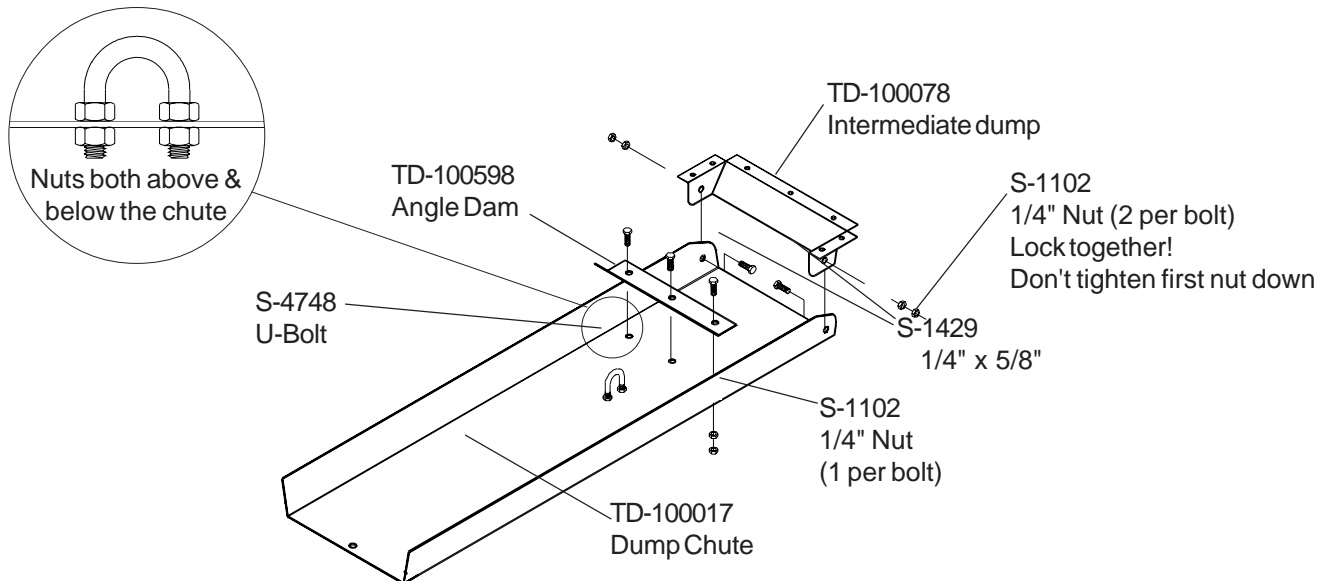
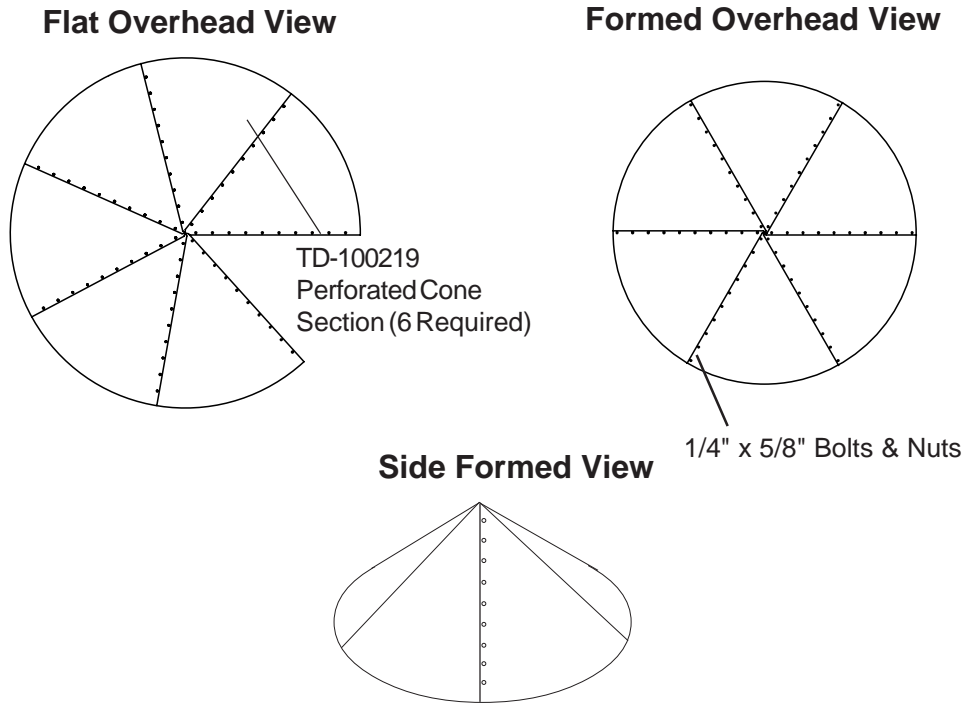

Figure #41

---

## CENTER CONE ASSEMBLY

Bolt the sections together to form perforated cone as shown below. Use 1/4" x 5/8" bolts and nuts to attach sections together.



## CENTER CONE INSTALLATION

Install cone over the center collar. Fasten Cone Assembly with (12) #10 x 3/4" self-drilling screws (S-280).

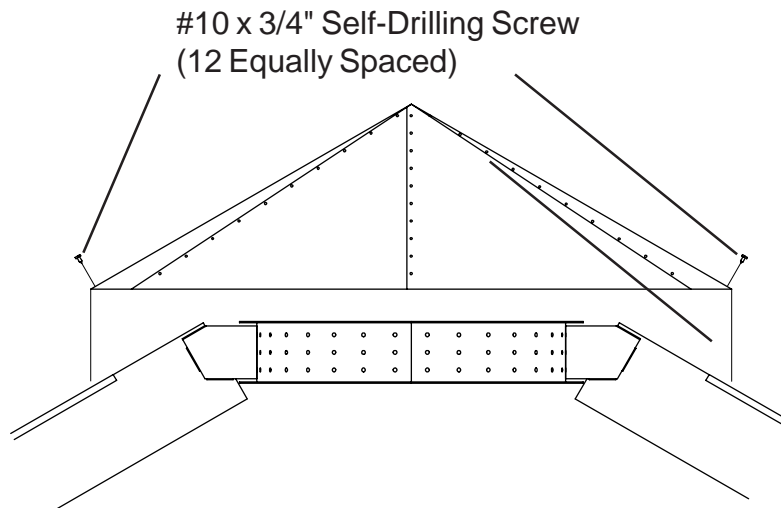

**Figure #42**



---

## ROOF ASSEMBLY SPECIAL INSTRUCTIONS

SEE ROOF INSTALLATION MANUAL LOCATED WITH ROOF HARDWARE PACKAGE.

1. Use TD-101017 Eave clips for 21'-24' tanks, and TD-101074 Eave Clips for 30'-36' tanks. The Top Dry Eave Clips are located in the Roof Hardware Package.
2. Locate eave clips so that a roof sheet will be centered over sidewall ladder.
3. Use TD-100274 Roof Brackets shipped in the Roof Hardware Package.

TD-101074  
Small Eave Clip  
TD-101017  
Large Eave Clip

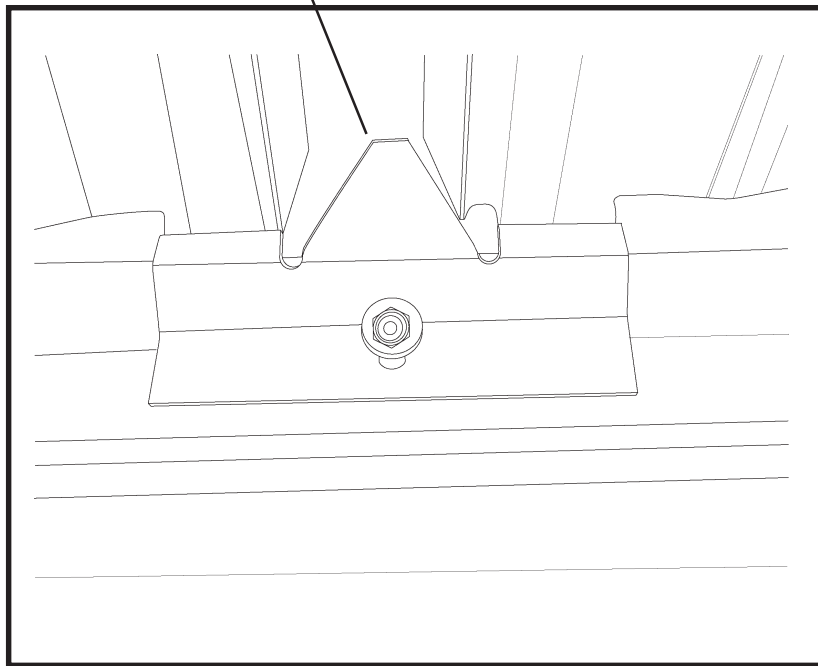

**Figure #43**

## 21' LEVELING BAND LOCATION

Position leveling bands as shown in the drawings below.

Use (2) 5/16" x 3/4" bin bolts to attach bands to posts. Also use 5/16" x 3/4" bin bolts to join band sections. **Note that band sections connect to each other only at endmost holes until completing the circle where an overlap may occur.**

### Inner Leveling Bands

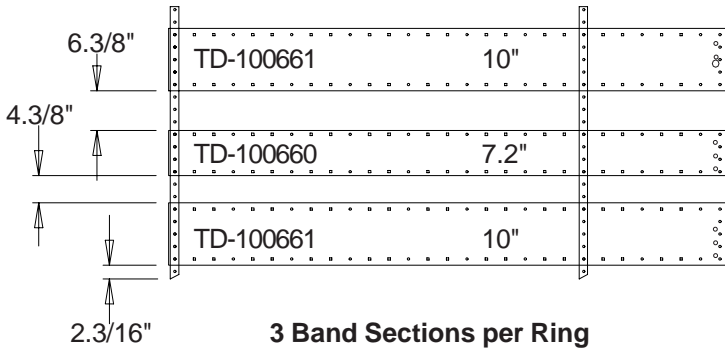

**3 Band Sections per Ring  
4 Bays w/15 Holes Between Posts  
and 1 Bay w/19 Holes Between Posts**

### Outer Leveling Bands

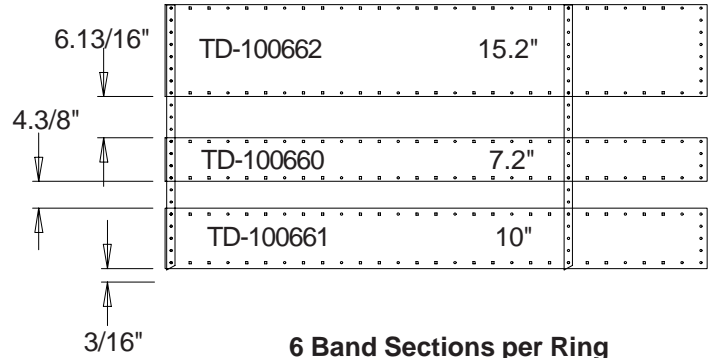

**6 Band Sections per Ring  
7 Bays w/23 Holes Between Posts**

Figure #44

## 24' LEVELING BAND LOCATION

Position leveling bands as shown in the drawings below.

Use (2) 5/16" x 3/4" bin bolts to attach bands to posts. Also use 5/16" x 3/4" bin bolts to join band sections. **Note that band sections connect to each other only at endmost holes until completing the circle where an overlap may occur.**

### Inner Leveling Bands

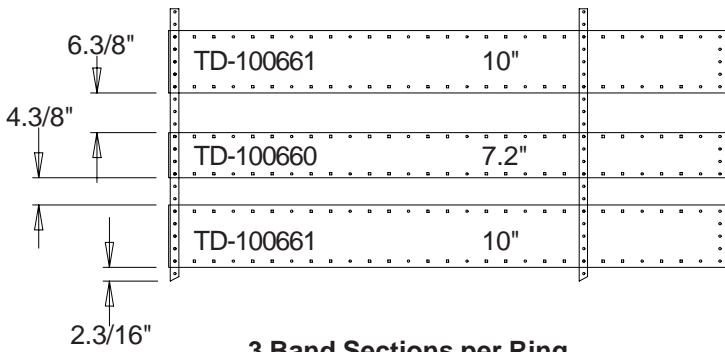

**3 Band Sections per Ring  
4 Bays w/20 Holes Between Posts**

### Outer Leveling Bands

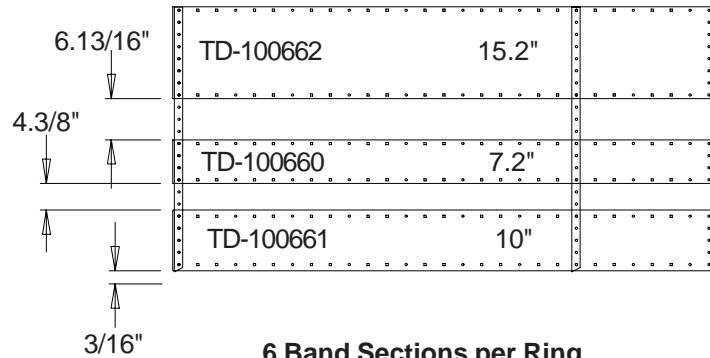

**6 Band Sections per Ring  
8 Bays w/20 Holes Between Posts**

Figure #45

# 30' LEVELING BAND LOCATION

Add leveling bands as shown in the relevant drawings to the right.

Use (2) 5/16" x 3/4" bin bolts to join band sections. Also use (2) 5/16" x 3/4" bin bolts to attach bands to posts. Note that band sections connect to each other only at endmost holes. Due to the odd number of rafters leveling band posts spacing is not equal on the inner and outer Leveling Bands.

## Inner Leveling Bands

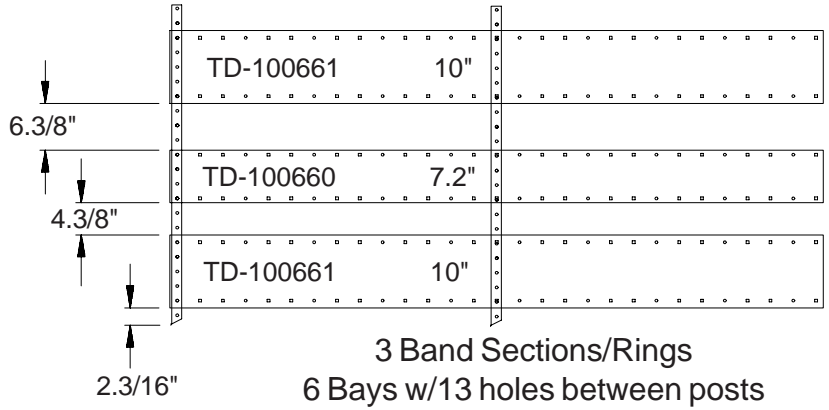

## Middle Leveling Bands

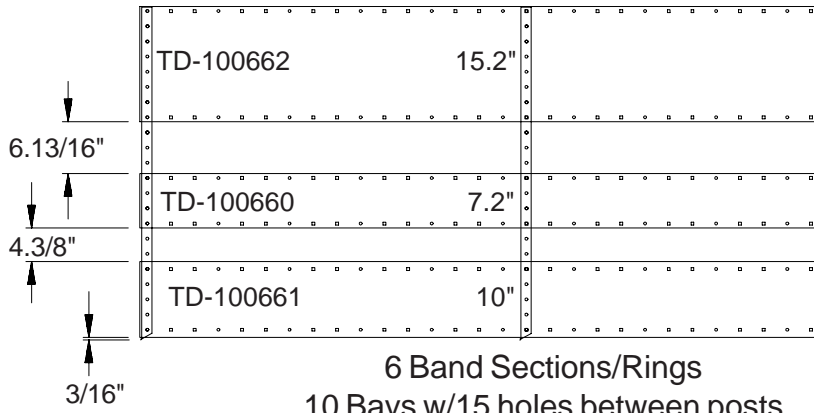

## Outer Leveling Bands

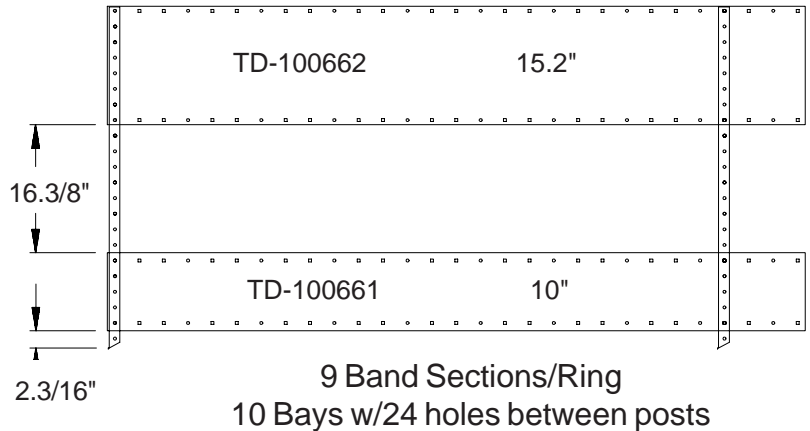

**Figure #46**

# 36' LEVELING BAND LOCATION

Add leveling bands as shown in the relevant drawings below.

Use (2) 5/16" x 3/4" bin bolts to join band sections. Also use (2) 5/16" x 3/4" bin bolts to attach bands to posts. Note that band sections connect to each other only at endmost holes. Due to the odd number of rafters leveling band posts spacing is not equal on the inner and outer Leveling Bands.

## Inner Set of Leveling Bands

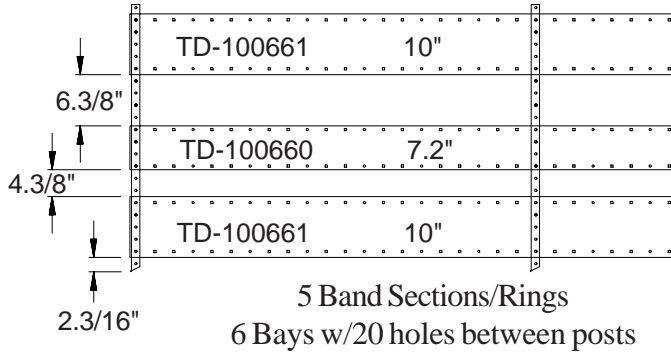

## No. 2 Set of Leveling Bands

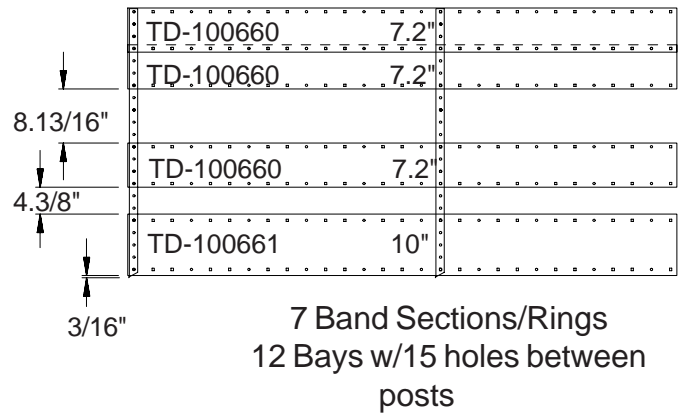

## No. 3 Set of Leveling Bands

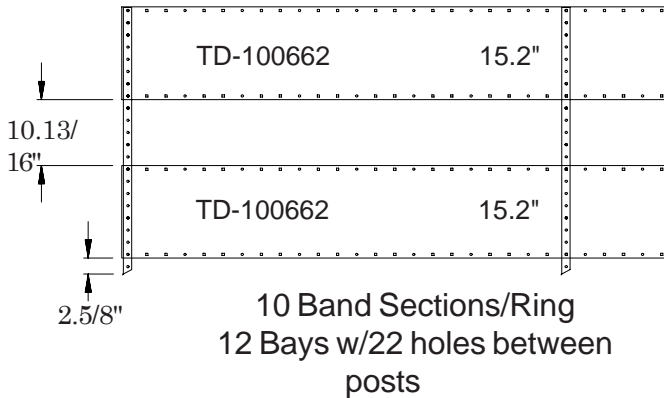

## Outer Set of Leveling Bands

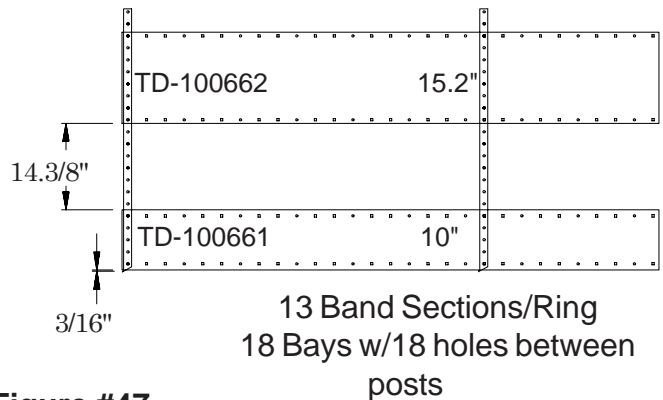
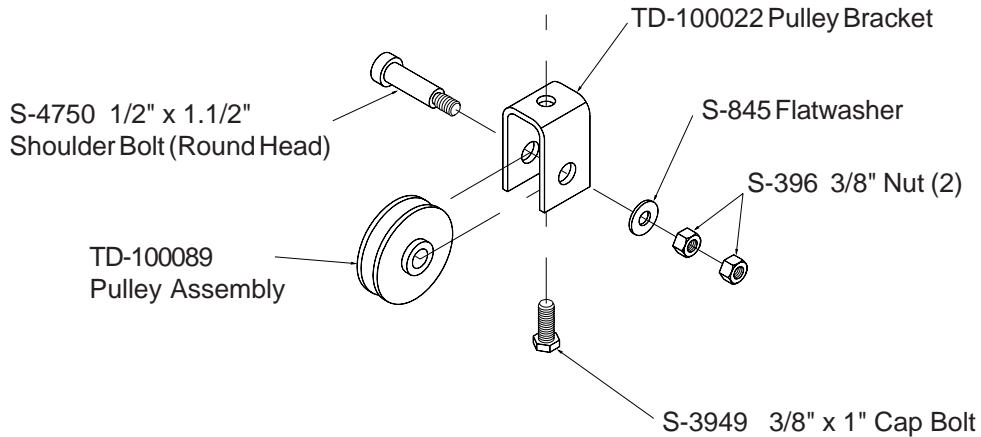

Figure #47

## PULLEY ASSEMBLY

Finish assembling the center collar by adding the cross channel. Position the pulley assembly to the cross channel in the middle of the center collar assembly. Use a 3/8" x 1" hex head cap bolt to fasten assembly to the cross channel. Position the pulley in the direction of the desired winch location on the sidewall.



**Figure #48**

Field drill (5) 3/8" diameter holes as shown at left. Attach the pulley assembly with 5/16" x 3/4" bolts with the neoprene on the inside of the bin.

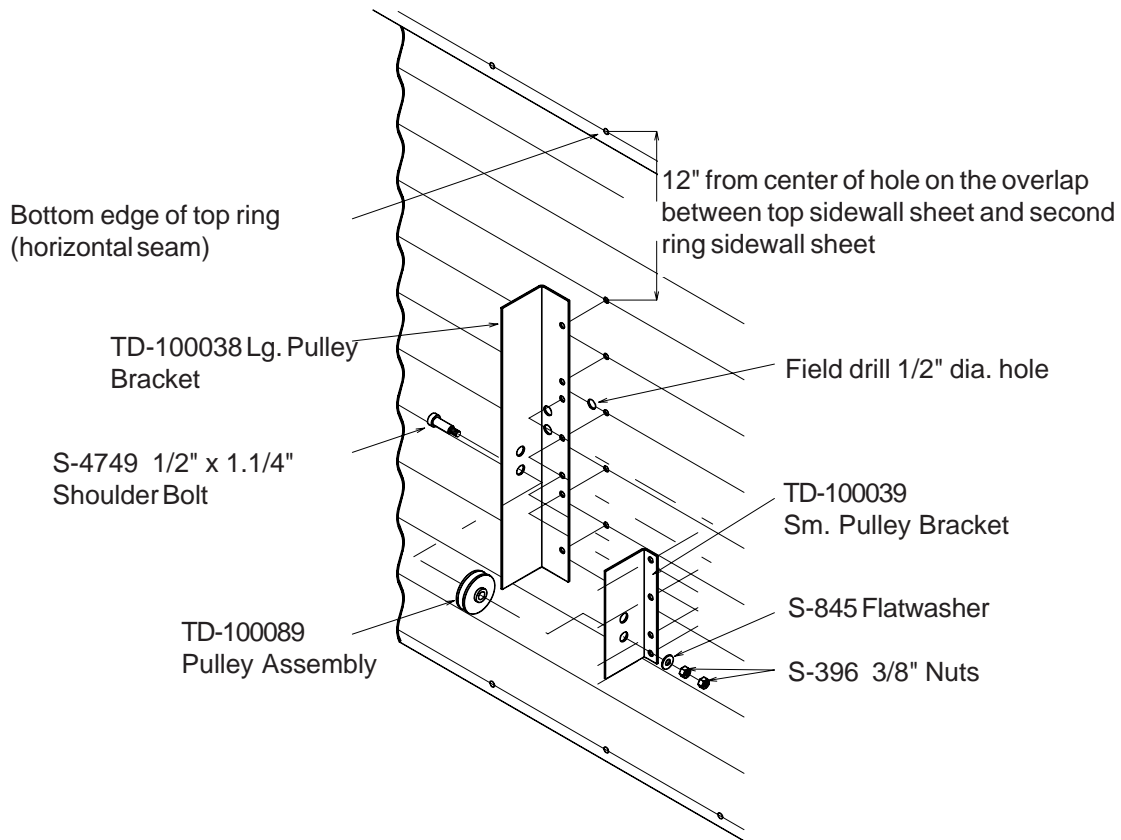
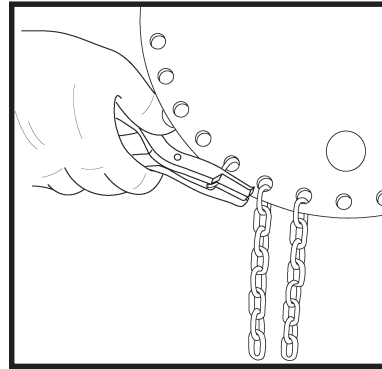

**Figure #49**

## DUMP CHUTE CHAIN ASSEMBLY

Attach all dump chute chains directly to the lift (TD-100801) plate as shown in diagram below.

Install all chains using "S" hooks (S-4692) to attach the chains to the dump chutes and lift plates. Keep excess chain at the lift plate. Adjust the chains until the chutes are approximately level when the lift plate is in the closed (up) position. Once the chains are uniformly adjusted, crimp the "S" hooks closed. Check when attaching the "S" hook to the end link on a chain that the end has not been cut open. If this is found remove the end link or shift up and use the next link in chain. The lift plate should be approximately 12" down from the cross channel when the chutes are level.



Crimp "S" hooks after final chute adjustment

**Figure #50**

### CHAIN LEADING TO OUTER CHUTES

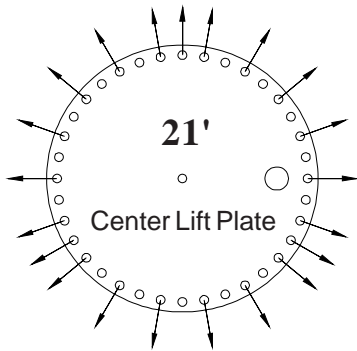

Chain leading to outer chutes (100") Adjust length as required (TD-100205)

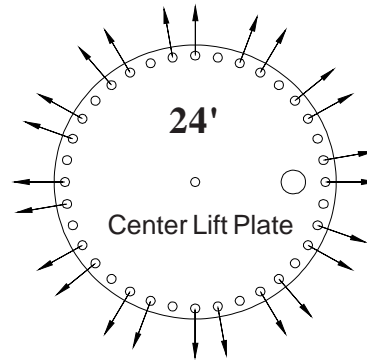

Chain leading to outer chutes (120") Adjust length as required (TD-100199)

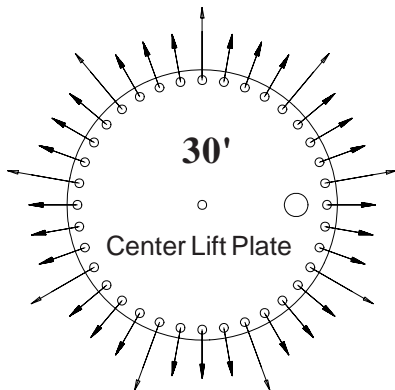

TD-100179 (Short Arrows)  
Chains leading to outer chutes (30) 160" Adjust lengths as required  
TD-100180 (Long Arrows)  
Chains to intermediate chutes (10) 96" Adjust lengths as required

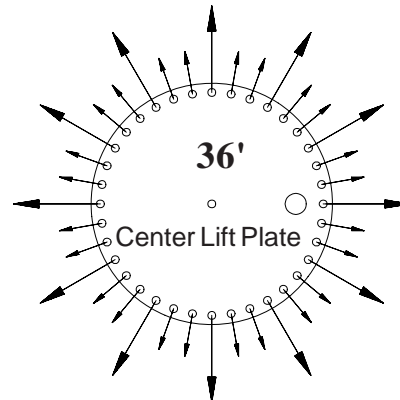

TD-100179 (Short Arrows)  
Chains leading to outer chutes (30) 160" Adjust lengths as required  
TD-100180 (Long Arrows)  
Chains to intermediate chutes (10) 96" Adjust lengths as required

**Figure #51**

# DUMP CHUTE CHAIN ASSEMBLY

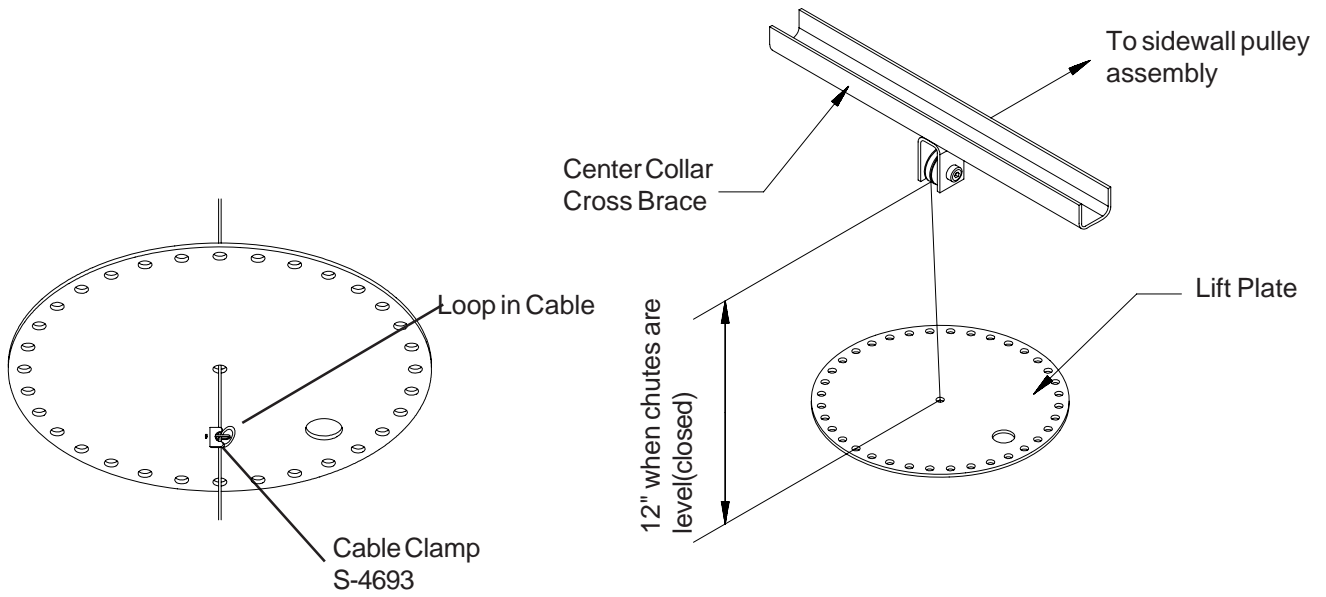

Chutes in closed position

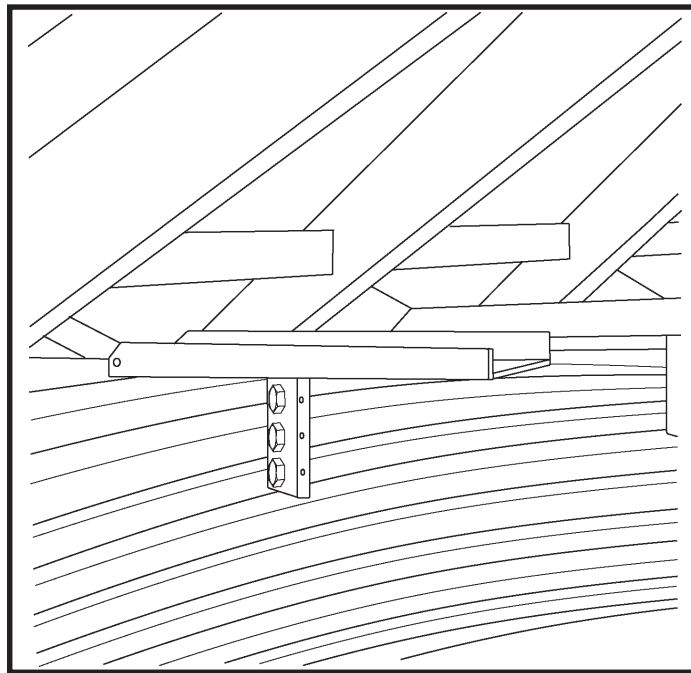
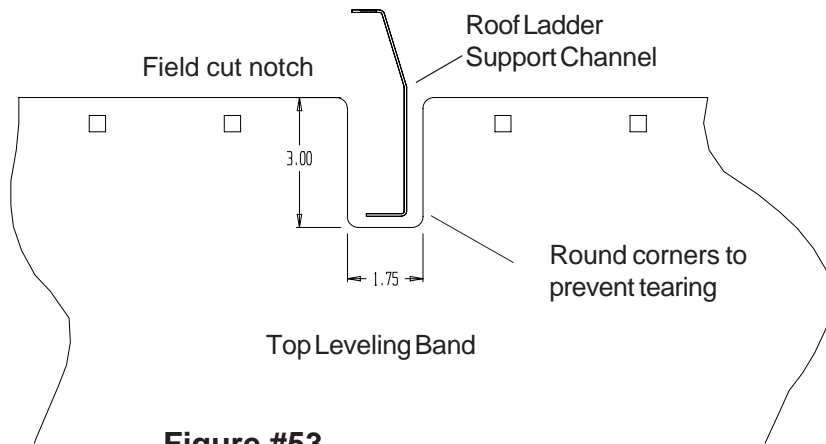

Figure #52

Note: Field cut rounded notches in the outer leveling band(s) where the two roof ladder support channels hang from the roof ribs.



**Figure #53**

## WINCH ASSEMBLY

Complete erection of bin. Install winch as shown using 5/16" x 3/4" bin bolts to attach to the sidewall. The cable clamps from either side of the pulley on the cross channel should be removed and the dump chutes pulled tightly shut. Check for the uniformity of the chains on the dump chutes and readjust if needed. The downward travel of the chutes must be limited to prevent damage on new Top Dry bins. This can be done after the bin is complete and the cable stop bracket and clamp is set to indicate when the dump chutes are fully closed. Open the chutes until the cable clamp is about 30" above the cable stop bracket. Attach another cable clamp just below the small outside pulley bracket making sure it is tight.

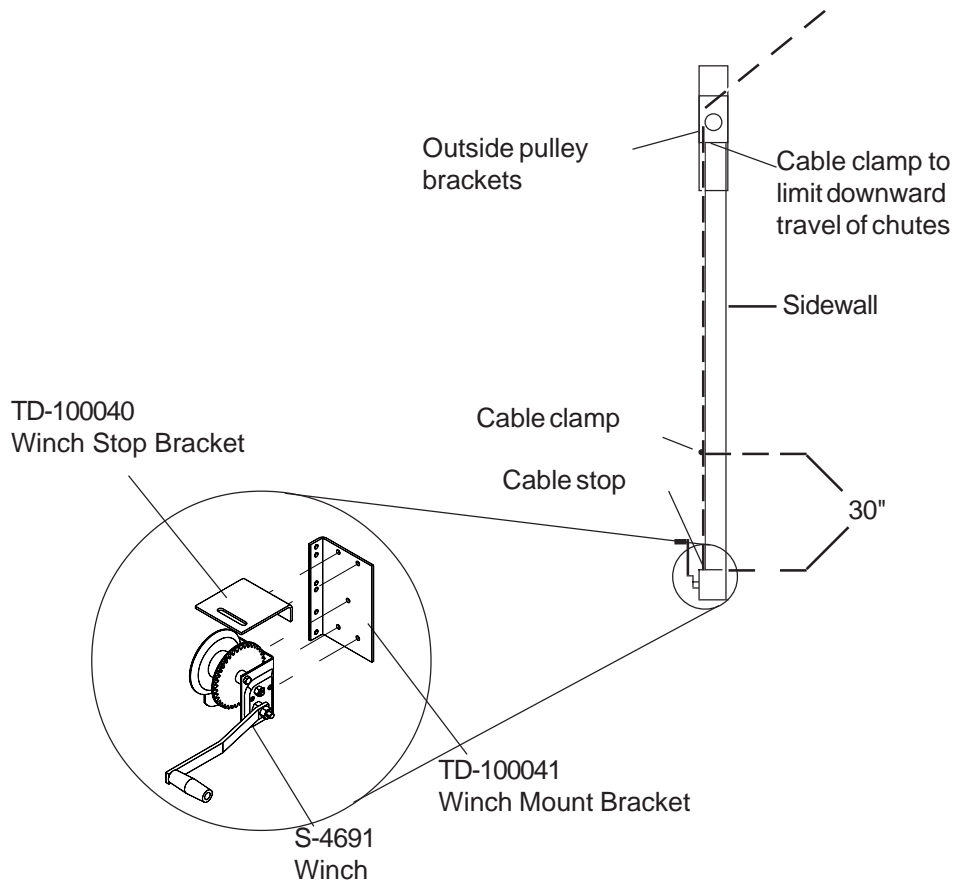

**Figure #54**



# FAN ENTRANCE SHEETS

24" thru 36" Fans

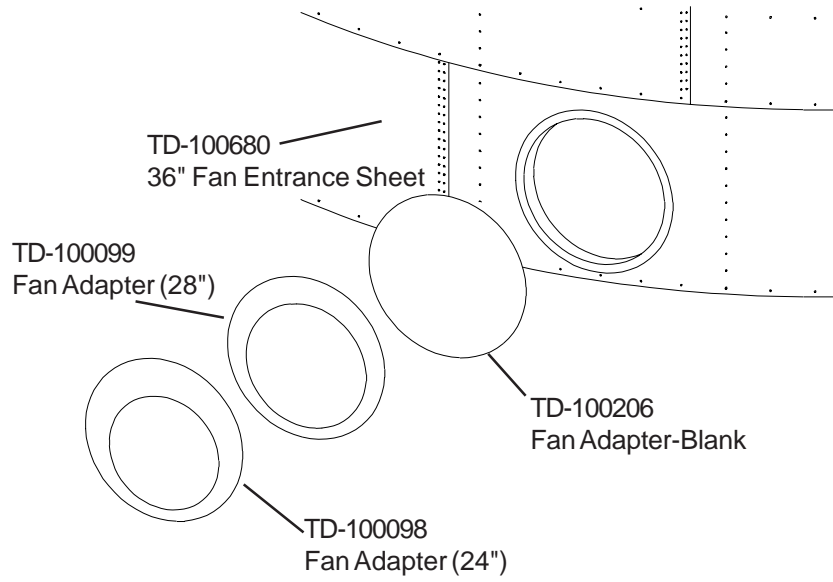

Figure #55

42" Fans

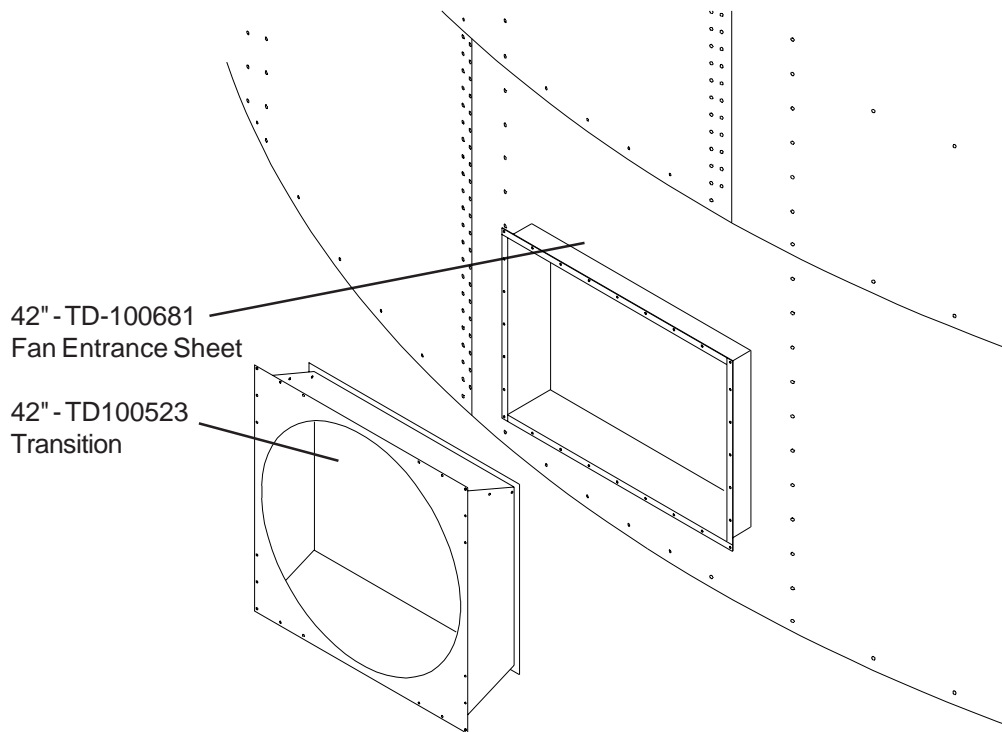
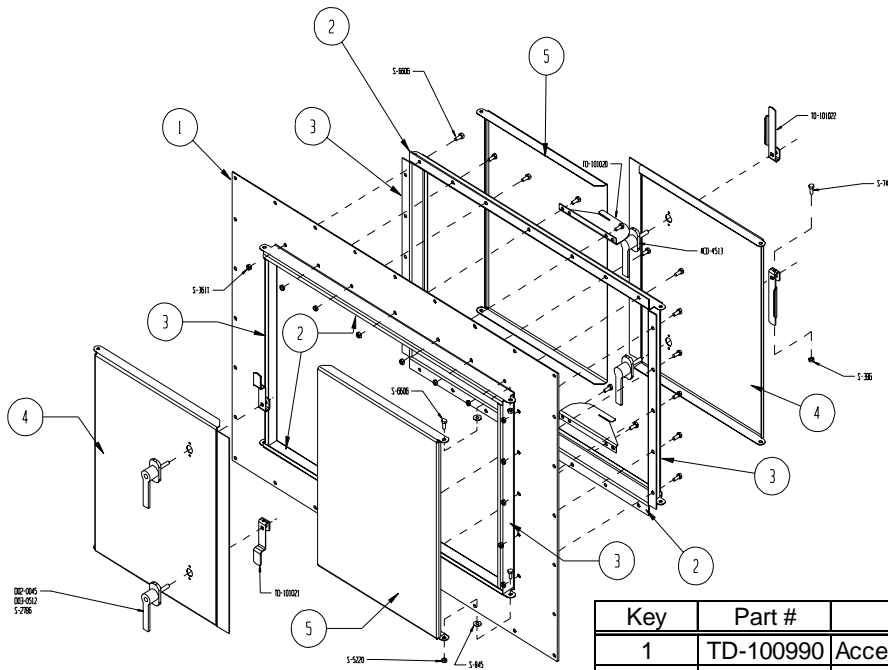

Figure #56

## Top Dry Access Door Assembly (TD-100996)

1. Assemble the Z-Frames (TD-100991 & TD-100992) and then attach the Frames (TD-100991 & TD-100992), to the inside of the Access Door Plate (TD-100990). **NOTE: The first set of Z-Frames comes pre-assembled to the Access Door Plate.**
2. Now attach the top and bottom Rear Door Catches (TD-101020) to the back of the Z-Frames. Referring to the layout, position the Catches with the left-hand most hole aligned with the center hole of the Access Door Plate.
3. Using washers to center the doors over the opening, attach the Top Access Door (TD-100993) and the Inside Access Door (TD-100994) to the Z-Frames. Utilize the lockwashers to secure the bolts to the doors. Do **not** overly tighten the lockwashers. This allows the doors to move freely.

4. Now attach the handles (D02-0045 & D03-0512) to the doors. **NOTE: The locking handles along with the hardware labeled "out," go to the outside doors. The rear handles have their own hardware package.**
5. With the nut and bolt supplied, attach the appropriate latches to the handles and lock them. (Refer to diagram). Adjust front latches (TD-101021) to catch the inside lip of the front Z-Frames. Adjust rear latches (TD-101022) to fit the slot in the top and bottom catches attached to the rear Z-Frames.
6. Attach the assembled access door to the access door panel (TD-101025).



**Figure #57**

Key	Part #	Description	Qty.
1	TD-100990	Access Door Plate	1
2	TD-100991	Access Top/Bottom Z-Frames	4
3	TD-100992	Access Door Side Z-Frames	4
4	TD-100993	Top Access Door	2
5	TD-100994	Inside Access Door	2
x	TD-101020	Rear Door Catches	2
x	TD-101021	Outside Door Latches	2
x	TD-101020	Inside Door Latches	2
x	D03-0512	Lockable Handle	2
x	D02-0045	Gasket for Lockable Handle	2
x	ACD-4513	Access Door Handle w/Gasket	2

# Detailed Layout For Proper Location Of Platforms

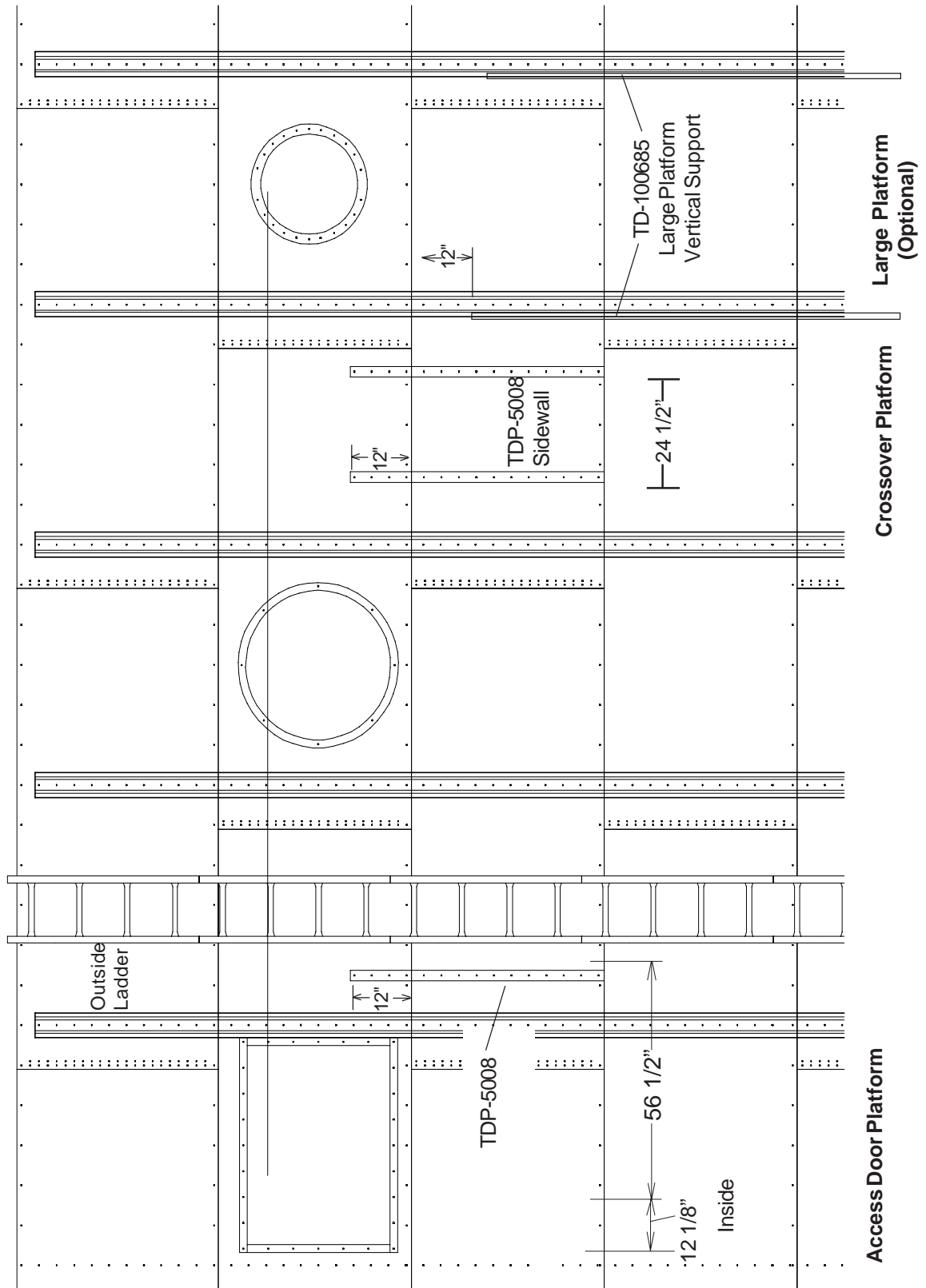

Figure #58

## ACCESS DOOR PLATFORM TDP- 5012

Before assembly of any platform, read the entire instructions to assure proper placement and assembly.

Refer to Figure #58 for proper location of access door platform. Begin by assembling the access door platform support frame using 5/16" x 3/4" truss head bolts and nuts. When attaching platform vertical support to bin sidewall field drill (16) 3/8" diameter holes for each support spaced every 4". Be sure and use 5/16" x 3/4" bin bolt on vertical support to sidewall. Special attention should be taken when assembling the platform support that the support brace is placed correctly.

Now proceed to the platform floor. Align holes on platform floor with holes on platform support and bolt together using 5/16" x 3/4" truss head bolt and nuts. Next, assemble handrail posts, handrails, and handrail braces.

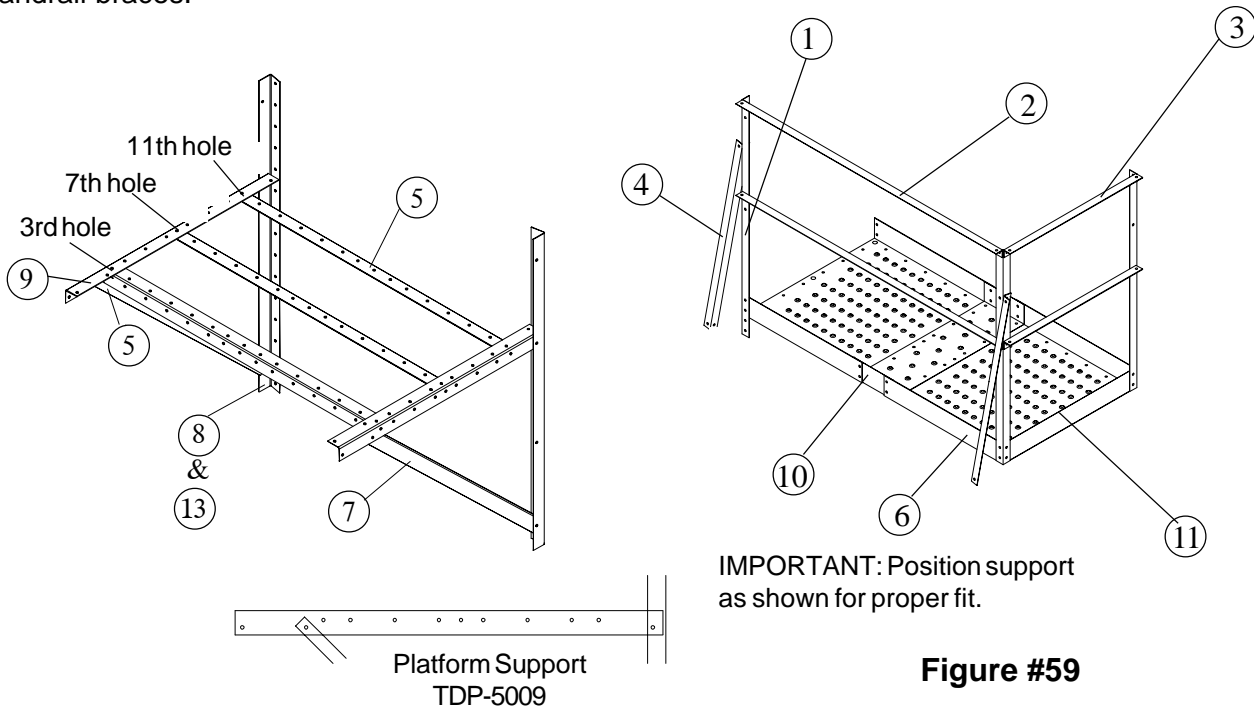

**Figure #59**

Key	Part No.	Description	Quantity	Weight
1	LS-371	Platform Vertical Angle 42"	3	11.38
2	TDP-5000	Handrail 59"	2	10.15
3	TDP-5002	Handrail 30"	2	10.15
4	TDP-5003	Handrail Brace 36.29/32"	2	6.34
5	TDP-5005	Floor Brace 58.1/2"	3	26.11
6	TDP-5006	Platform Floor 37.7/8"	2	38.23
7	TDP-5007	Support Brace 50.21/32"	2	15.08
8	TDP-5008	Sidewall Brace 58"	2	19.65
9	TDP-5009	Platform Support 43.1/2"	2	12.95
10	TDP-5010	Platform Floor Splice 37.1/2"	1	6.24
11	TDP-5011	Platform Toe Plate 29.3/4"	1	3.29
12	TDP-5014	Access Door Package Hardware	1	5.41
13	TDP-5008N	Sidewall Brace 2.66"	2	16.61

# LARGE PLATFORM ASSEMBLY

## For 42" Fan

Before assembly of any platform, read the entire instructions to assure proper placement and assembly.

Refer to Figure #58 for proper location of large platform. Begin by assembling the large platform support frame using 7/16" x 1" bolts on all connections. Use 5/16" x 1.1/4" bin bolt to attach the platform vertical supports to the sidewall stiffeners. Be sure and place the 5/16" x 1.1/4" bolts from the inside of the bin to the outside. This will provide maximum weather protection.

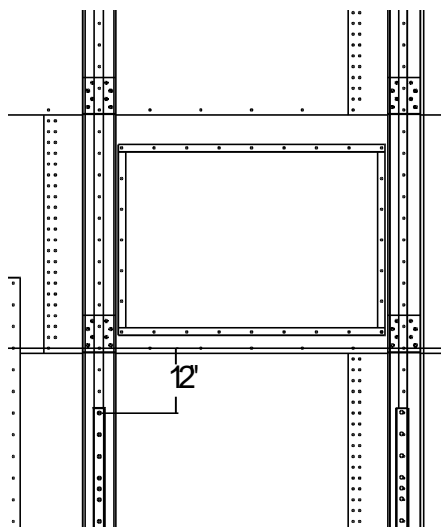

Figure #60

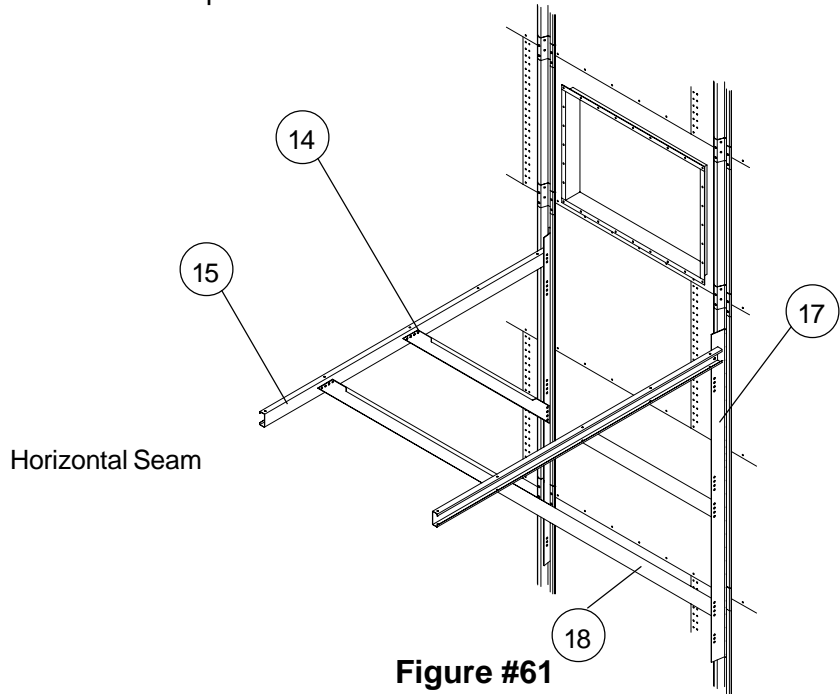
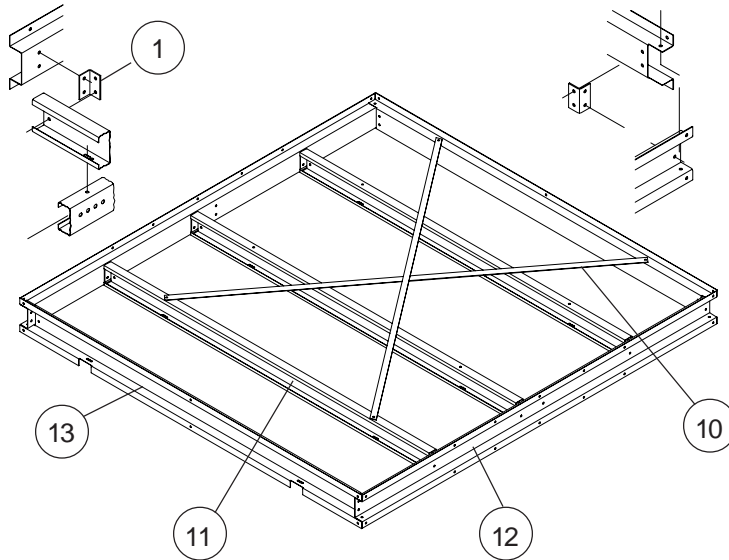

Figure #61

Key	Part No.	Description	Quantity	Weight
1	TD-100051	Channel Bracket	10	4.87
2	TD-100052	Handrail Post 49.3/4"	7	55.47
3	TD-100053	Toeboard 71.1/2"	1	4.99
4	TD-100054	Toeboard 92"	1	6.42
5	TD-100055	Toeboard 95.1/2"	1	6.67
6	TD-100056	Handrail 71.1/2"	2	17.07
7	TD-100057	Handrail 92"	2	22.98
8	TD-100058	Handrail 95.1/2"	2	22.81
9	TD-100063	Floor Plank 95.1/2"	13	163.35
10	TD-100065	"X" Brace Strap 94.5/16"	2	8.75
11	TD-100068	Mid Channel Support 88"	3	58.37
12	TD-100069	Side Channel Support 96"	2	50.46
13	TD-100071	End Channel Support 92.1/2"	2	49.15
14	TD-100085	Short Knee Brace 72.9/32"	2	54.51
15	TD-100086	Support Channel 98.3/8"	2	53.08
16	TD-100087	Long Knee Brace 114"	2	85.98
17	TD-100685	Vertical Support 94"	2	63.64
18	TD-100091	Large Platform Hardware Package	1	14.35

## Large PLATFORM Assembly (cont.) (FOR 1 FAN SYSTEMS OR #2 FAN ON 2 FAN SYSTEMS)



Position the vertical support to the existing sidewall stiffeners as shown in Figure #62 and double nut with 5/16" nuts.

**Figure #62**

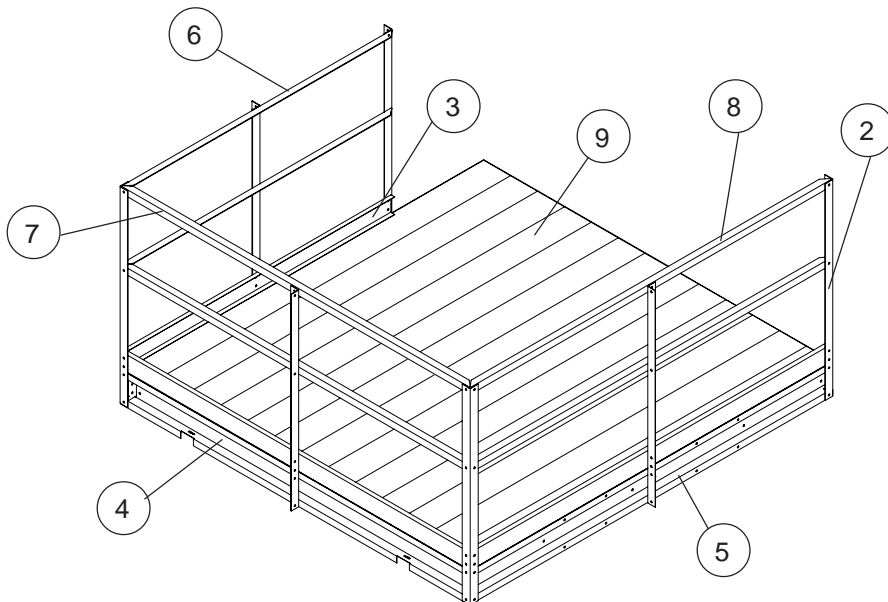

When bolting stiffener to sidewall at locations where platform supports are to be attached, use (25) 5/16" x 1.1/4" bin bolts, heads to in side. Start 12 inches below horizontal seam of second and third rings from top. See Figure #63.

**Figure #63**

## 42" FAN DIFFUSER INSTRUCTIONS & INSTALLATION

Bolt the long side of the hangers to the endmost slots of the top plate (TD-100665) as shown below.

Hold the top plate up under the bottom flange of the "C" channel in front of the fan opening. Mark and drill four 3/8" holes into bottom flange using diffuser hangers as a guide. Using 5/16" x 3/8" bolts and nuts bolt the top plate to the "C" channel.

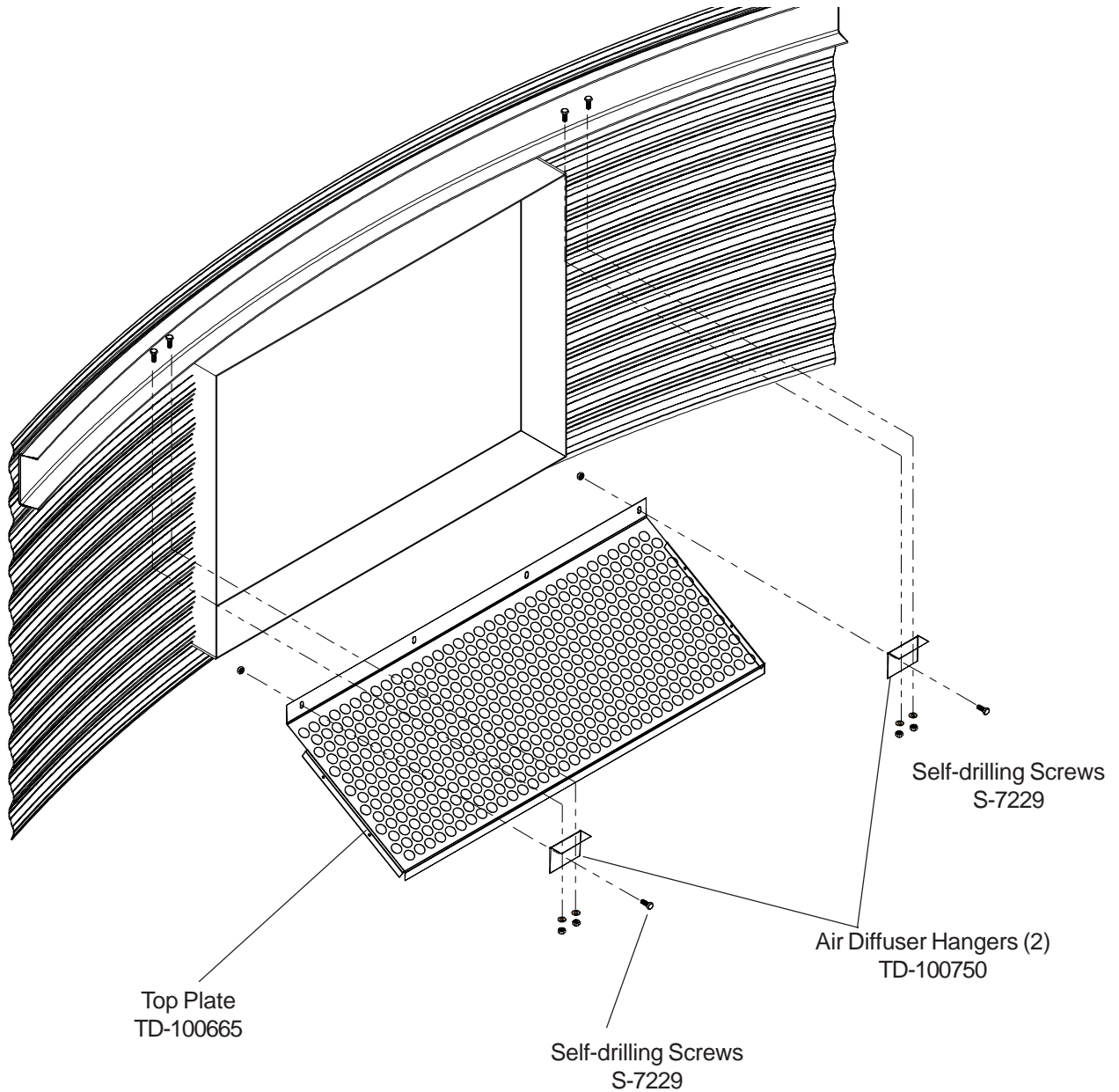

**Figure #64**

## 42" FAN DIFFUSER (CONT.)

Attach front plate to the top plate with four (4) 1/4" x 1" self-drilling screws.

Bolt the side brackets to the front plate slot with the angle outward. Field drill two (2) holes (on inside corrugation hills) through the sidewall and install 5/16" x 3/4" bin bolts and nuts.

Position the side plates on each side with the angle outward and fasten in place using six (6) 1/4" x 1" self-drilling screws.

**NOTE: The corner bolt will need to be removed through the side plate, side bracket and front plate.**

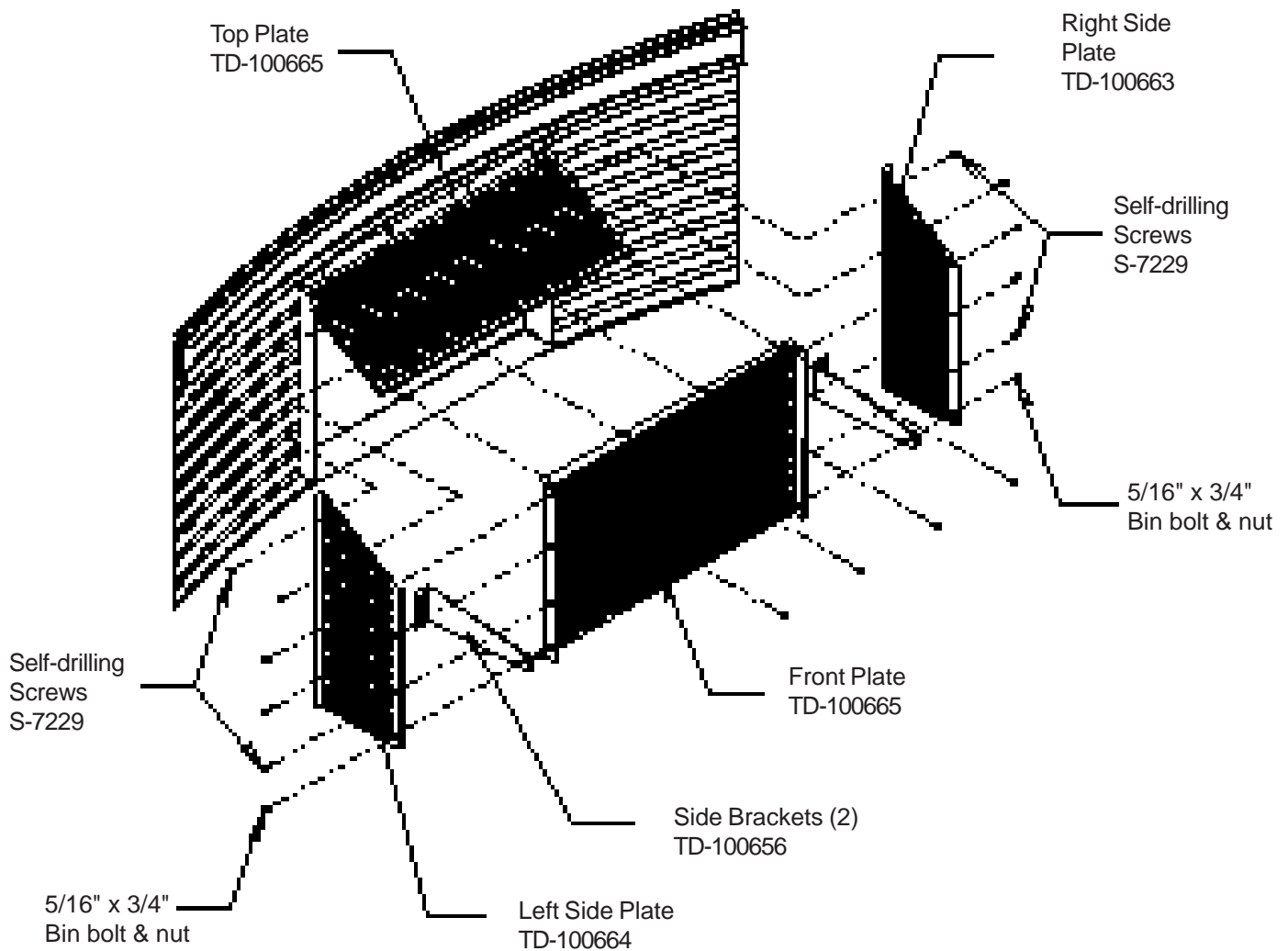

**Figure #65**



## CROSS OVER PLATFORM ASSEMBLY (For use with stairs) TDP-5013

Before assembly of any platform, read the entire instructions to assure proper placement and assembly.

Refer to Figure #58 for proper location of cross over platform. Begin by assembling the cross over platform support frame using 5/16" x 3/4" truss head bolts and nuts. When attaching platform vertical support to bin sidewall field drill (16) 3/8" diameter holes for each support spaced every 4". Be sure and use 5/16" x 3/4" bin bolt on vertical support to sidewall. Special attention should be taken when assembling the platform support that the support brace is placed correctly.

Now proceed to the platform floor. Align holes on platform floor with holes on platform support and bolt together using 5/16" x 3/4" truss head bolt and nuts. Next, assemble handrail posts, handrails, and handrail braces.

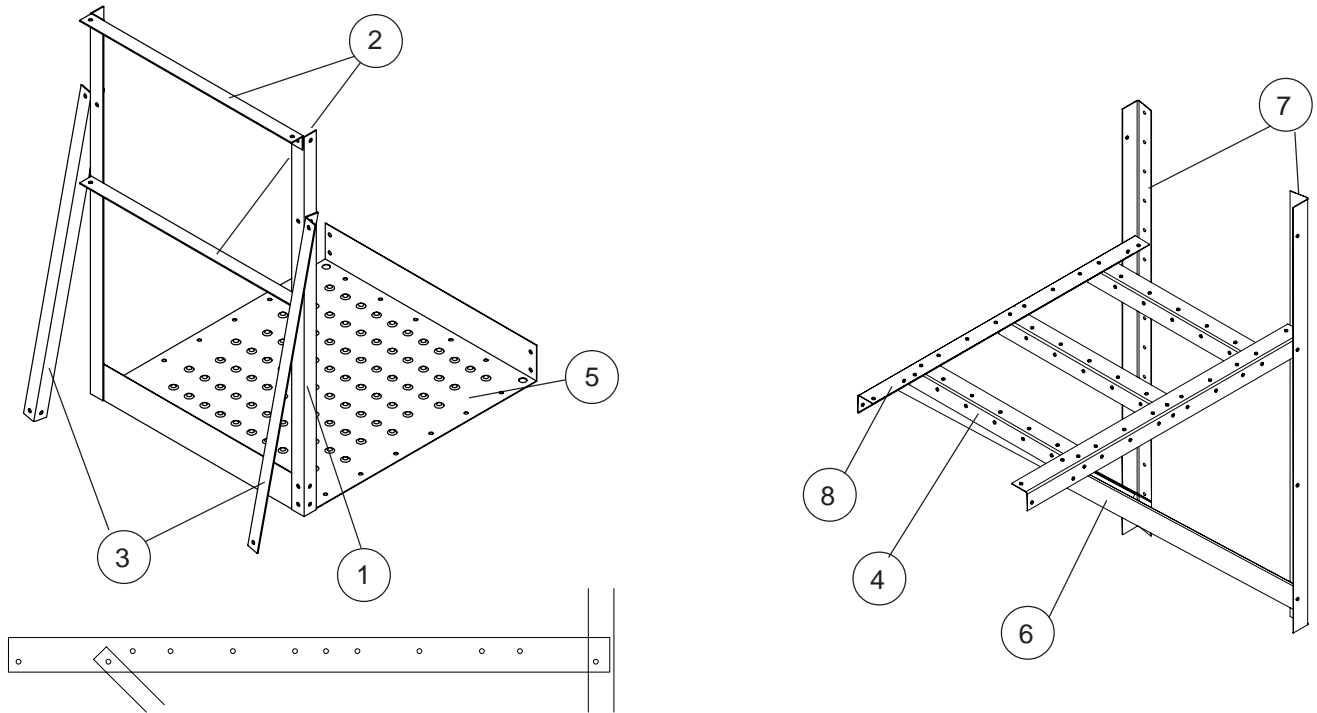
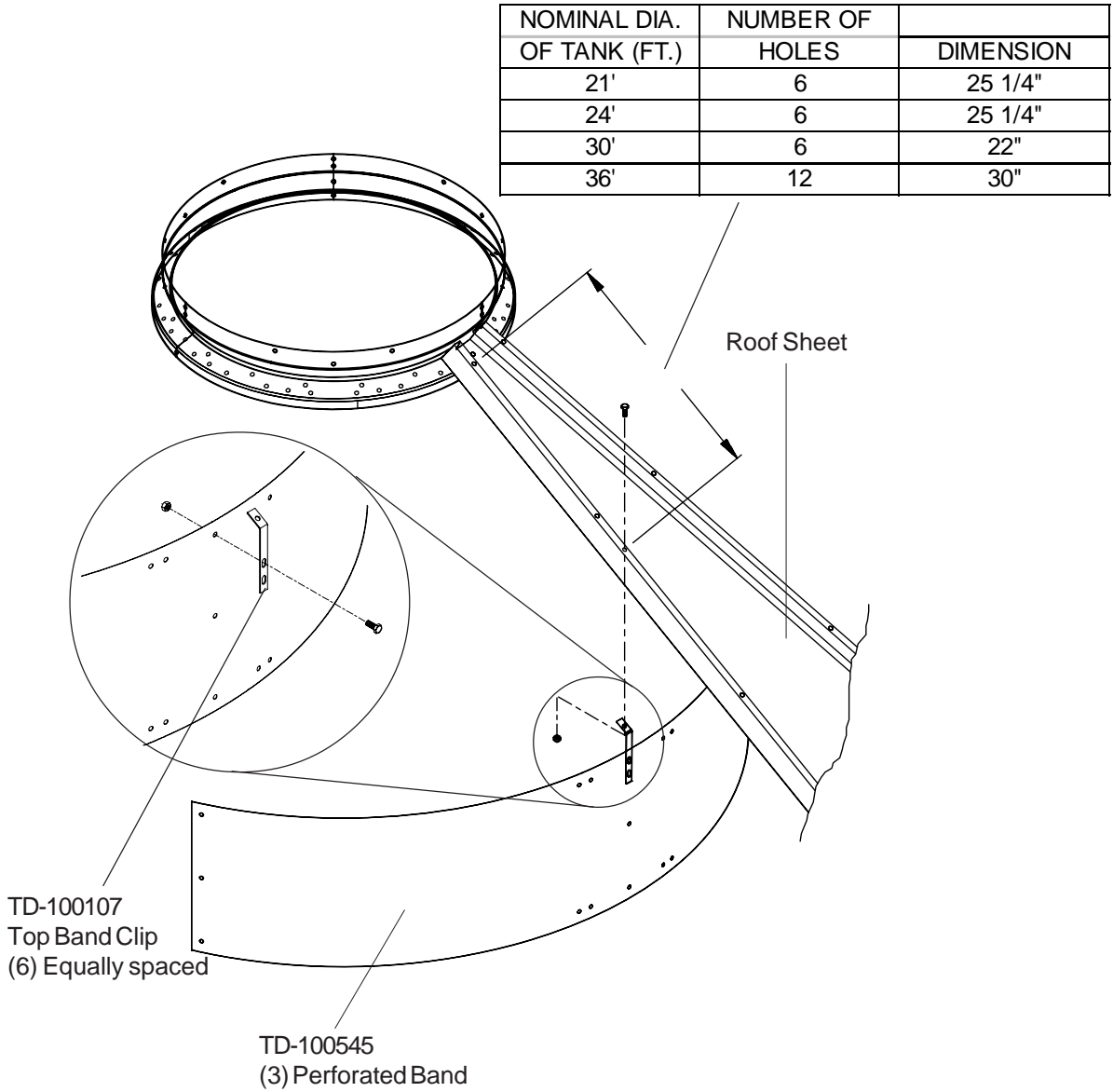

**Figure #66**

Key	Part No.	Description	Quantity	Weight
1	LS-371	Platform Vertical Angle	2	7.59
2	TDP-5001	Handrail 27"	2	4.63
3	TDP-5003	Handrail Brace 36.29/32"	2	6.34
4	TDP-5004	Short Floor Brace 26.1/2"	3	11.85
5	TDP-5006	Platform Floor 37.7/8"	1	19.11
6	TDP-5007	Support Brace 50.21/32"	2	15.08
7	TDP-5008	Sidewall Brace 58"	2	19.65
8	TDP-5009	Platform Support 43.1/2"	2	12.95
	TDP-5015	Cross Over Plat. Hdw. Pack.	1	3.95

## PERFORATED CENTER BAND

Drill (6) 3/8" diameter holes equally spaced as shown above for top band clips. Attach clips using 5/16" x 3/4" bin bolts. Add perforated band sections. Note that these do not attach to the leveling bands but hang down on the inside of the top inner leveling band.



**Figure #67**

NOMINAL DIA. OF TANK (FT.)	PART NUMBER "A"	QUANTITY
		REQUIRED
21'	TD-100219	3
24'	TD-100219	3
30'	TD-100545	6
36'	TD-100726	6

# OPTIONAL ROTARY SWITCH ROOF LOCATIONS

## Overhead View of optional rotary Switch Locations

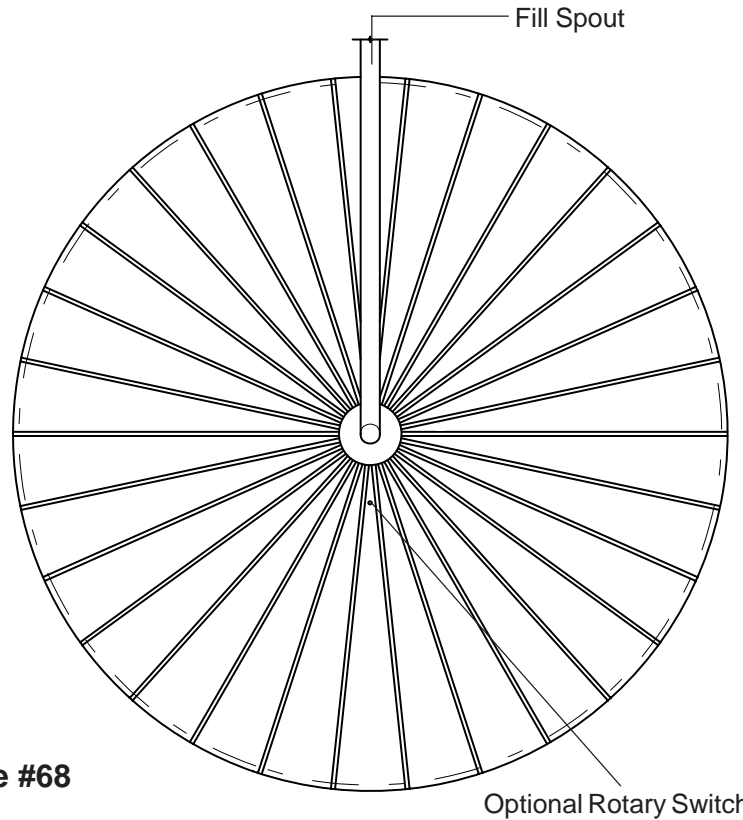

Figure #68

## OPTIONAL ROTARY SWITCH PANEL LOCATION

Drill 2" diameter holes through roof panels at locations shown on previous page. Use a mounting plate as a pattern and drill (4) 3/8" holes through roof panels at each switch location so the plate can be bolted to the roof.

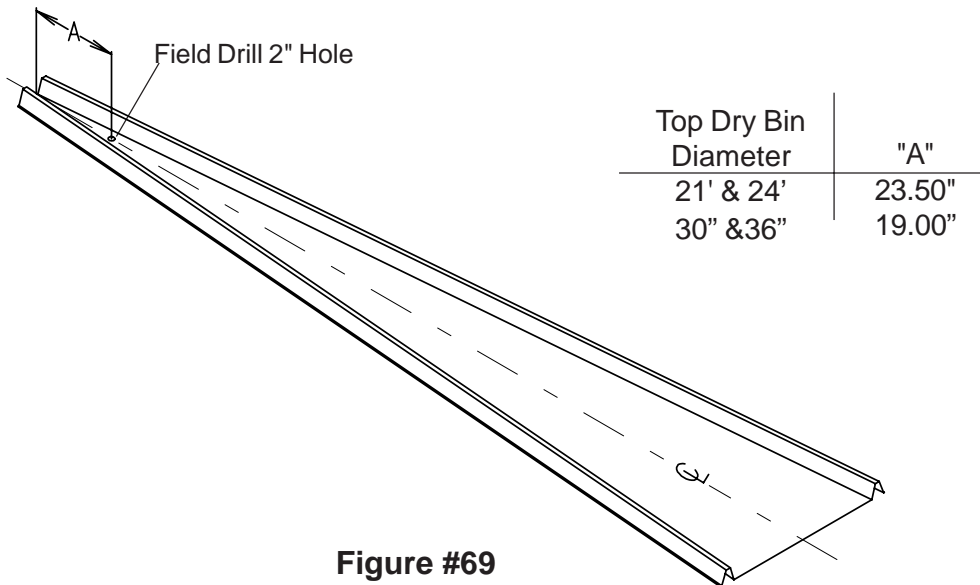

Figure #69

## OPTIONAL INSTALLATION OF ROOF-MOUNTED LEVEL SWITCH

Drill 2" diameter holes through roof panels at locations shown on previous page. Use a mounting plate as a pattern and drill (4) 3/8" holes through roof panels at each switch location so the plate can be bolted to the roof.

Attach flex-coupling to the power-pak and install roll pin. Apply teflon tape or pipe sealant (not included) to power-pak pipe threads and thread power-pak into mounting plate coupling. Conduit opening in power-pak should be at right angles to roof rib or face toward eave.

Caulk underside of mounting plate above and both sides of 2" hole. Bolt to roof panel.

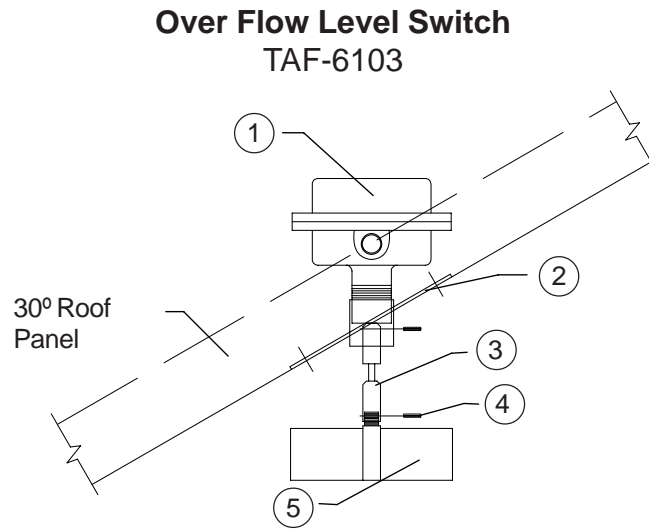

**Figure #70**

Key	Part No.	Description	Quantity	Weight
1	TD-100076	Rotary Switch Power-Pak	1	3.50
2	TD-100627	Roof Mount Coupling Weldment	1	2.14
3	TD-100075	Flex-Coupling	1	0.50
4	S-7241	1/8" x 1.1/4" Cotter Pin	2	0.02
5	TAF-6086	3-Vane Paddle	1	0.75
*	TAF-6097	Hardware Package	1	0.98
--	PNEG-300	Rotary Switch Instructions	1	0.04
--	S-275	5/16" - 18 x 3/4" Bin Bolt	6	0.16
--	S-3651	Tube Seal	1	0.74
--	S-396	5/16" - 18 Hex Nut	6	0.06
--	S-7241	1/8" x 1.1/4" Cotter Pin	2	0.02

\* **Hardware Package not shown**

- **Included in Hardware Package**

## OPTIONAL INSTALLATION OF WALL-MOUNTED ROTARY SWITCHES

**IMPORTANT: Note: Wall mounted switch must be located at least 3' below the fan opening.**

Drill 2" hole through wall 3' below the upper fan and heating unit(s), hole should be centered on outside valley.

Position mount plate (from inside), mark and drill 3/8" holes. Caulk coupling abundantly where it passes through the wall. Add foam weather strip around top and sides of plate then bolt to bin wall. Caulk coupling to wall from outside. Attach flex coupling to power-pak. Add teflon tape or pipe (sealant not included) to power-pak pipe threads and thread in to coupling. Conduit opening should be horizontal or down. Add one-vane paddle.

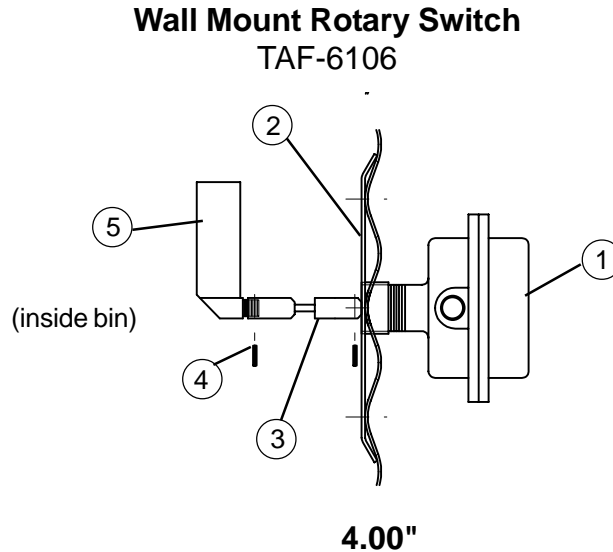

**Figure #71**

Key	Part No.	Description	Quantity	Weight
1	TD-100076	Rotary Switch Power-Pak	1	3.50
2	TD-100629	Roof Mount Coupling Weldment	1	2.14
3	TD-100075	Flex-Coupling	1	0.50
4	S-7241	1/8" x 1.1/4" Cotter Pin	2	0.02
5	TAF-6085	1-Vane Paddle	1	0.75
*	TAF-6097	Hardware Package	1	0.98
--	PNEG-300	Rotary Switch Instructions	1	0.04
--	S-275	5/16" - 18 x 3/4" Bin Bolt	6	0.16
--	S-3651	Tube Seal	1	0.74
--	S-396	5/16" - 18 Hex Nut	6	0.06
--	S-7241	1/8" x 1.1/4" Cotter Pin	2	0.02

## TRANSITION INSTALLATION (TR-4734)

BEFORE CUTTING THE OPENING CHECK THAT TR-4734 IS THE TRANSITION  
THAT WAS ORDERED.

When installing the GSI aeration transition, it will be necessary to field cut a hole into the bottom sidewall ring (usually straight across from the unload auger). Refer to diagram for proper dimensions of cutout. The base angle will also need to be cut at entrance collar cutout. Take note of the diagram showing the 1" dimension from bottom of entrance collar side bracket to concrete. This is important for proper fit of transition.

**NOTE:** Entrance collar side bracket must be bolted on the inside of the bin sidewall.

### AS VIEWED FROM INSIDE BIN

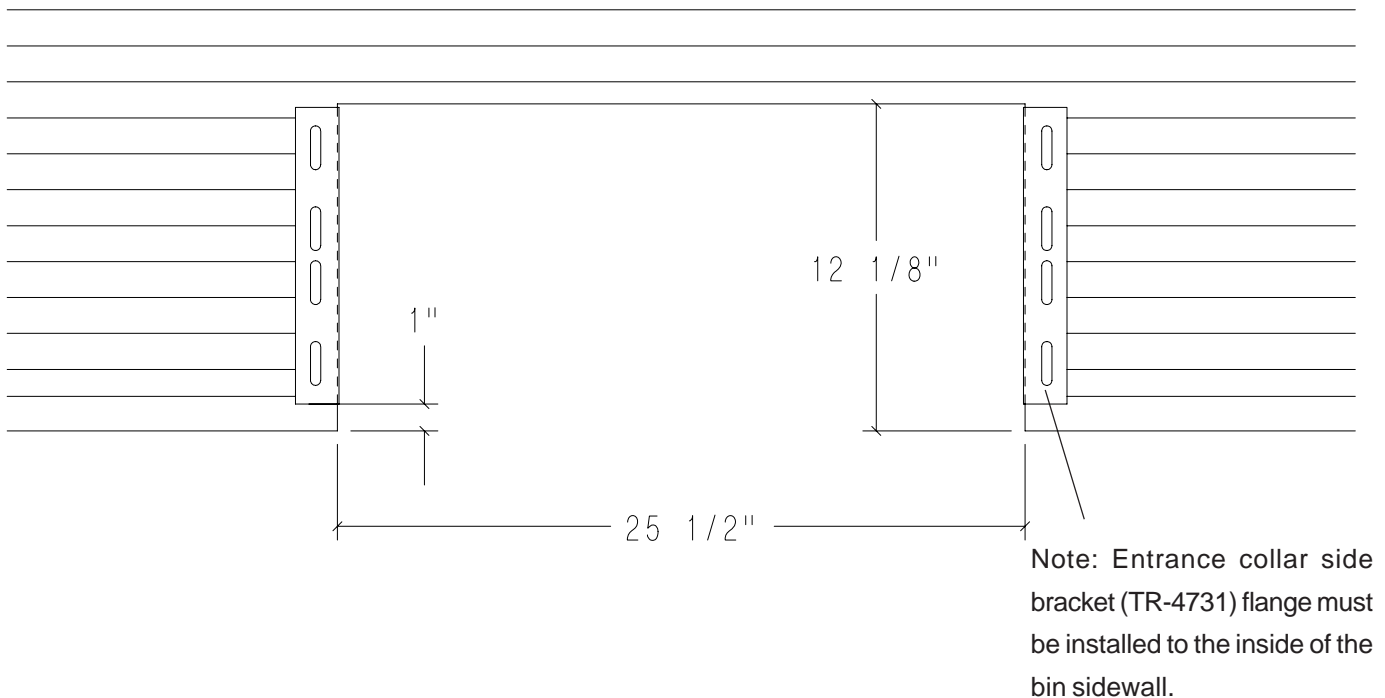

**Figure #72**

Part No.	Description	Quantity
S-275	5/16" - 18 3/4" Bin Bolt Grade 5	125
S-280	#10 - 16 x 5/8" Self Drill Screw	10
S-3651	Tube Caulk - Gray Butyl #506-15	1
S-396	5/16" - 18 Hex Nut Grade 2	125
S-7264	Spec Neoprene Seal Strip W/ADH	10 Ft

## TRANSITION ASSEMBLY (TR-4734)

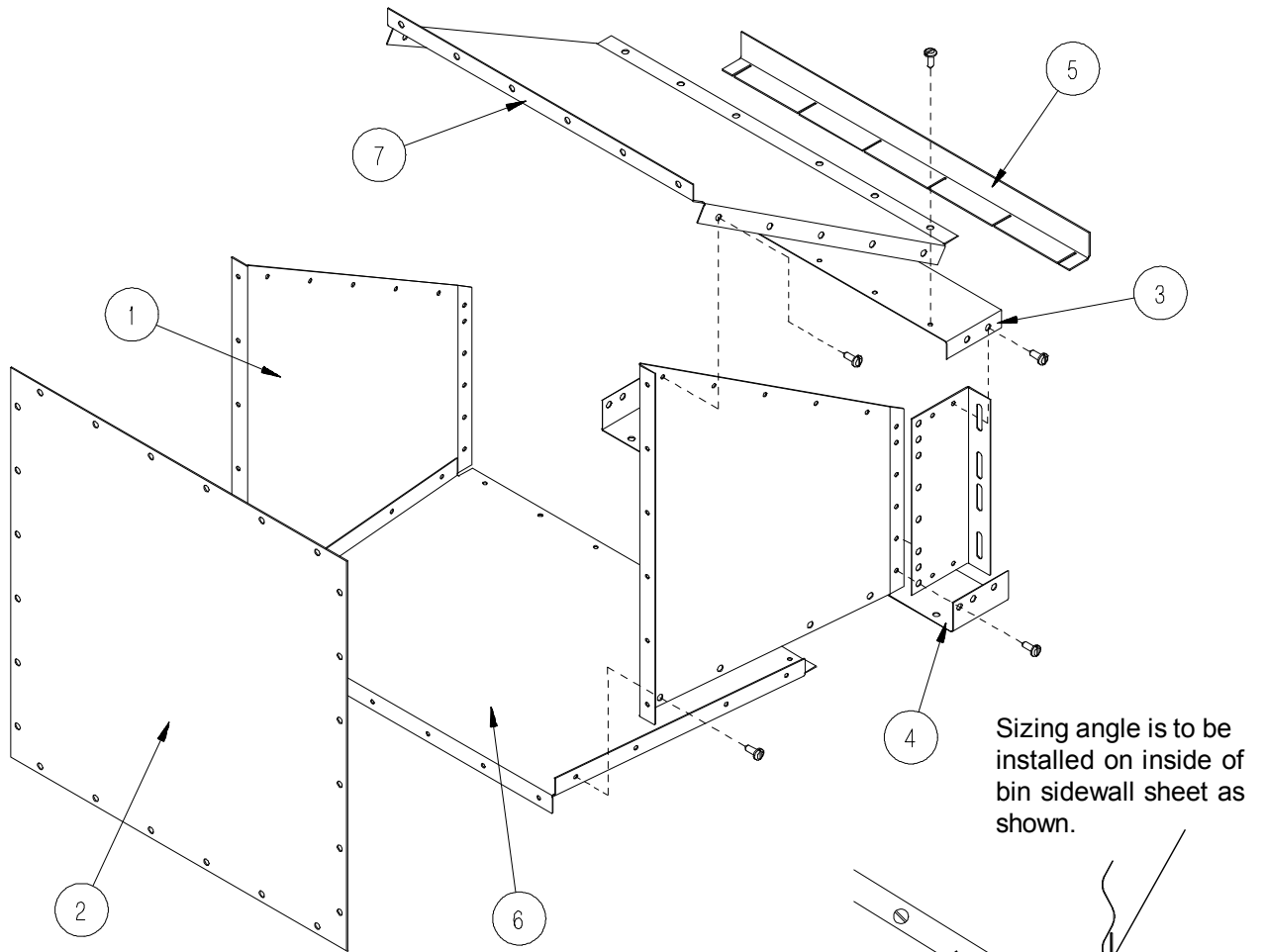

- \* Hardware Package not shown
- Included in Hardware Package

The flanges on transition top are to go on the outside of transition sides. The flanges on transition bottom are to go on the inside of transition sides.

**Figure #73**

Key	Part Number	Description
1	TR-4724-1	Transition side
1	TR-4724-2	Transition side
2	TR-4767	Transition faceplate
3	TR-4726	Top entrance collar piece
4	TR-4727	Bottom entrance collar
5	TR-4728	Sizing angle
6	TR-4729	Transition bottom
7	TR-4730	Transition top
8	TR-4731	Entrance collar side bracket

---

## TWO RING DOOR INSTALLATION INSTRUCTIONS

Before starting to install, be sure the correct door has been received.

### 4.00" Corrugation

WD-6133 21' Bins

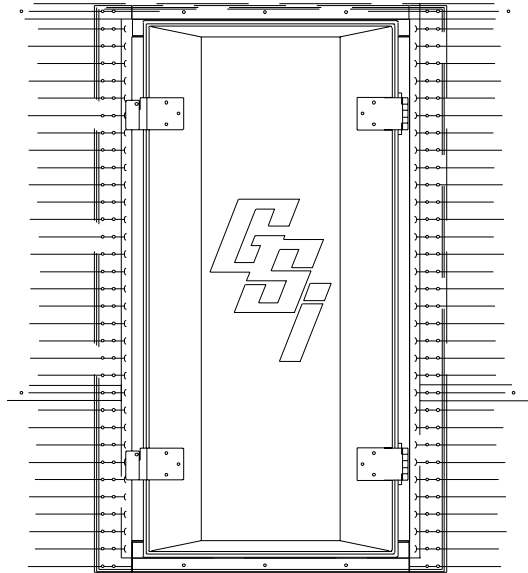
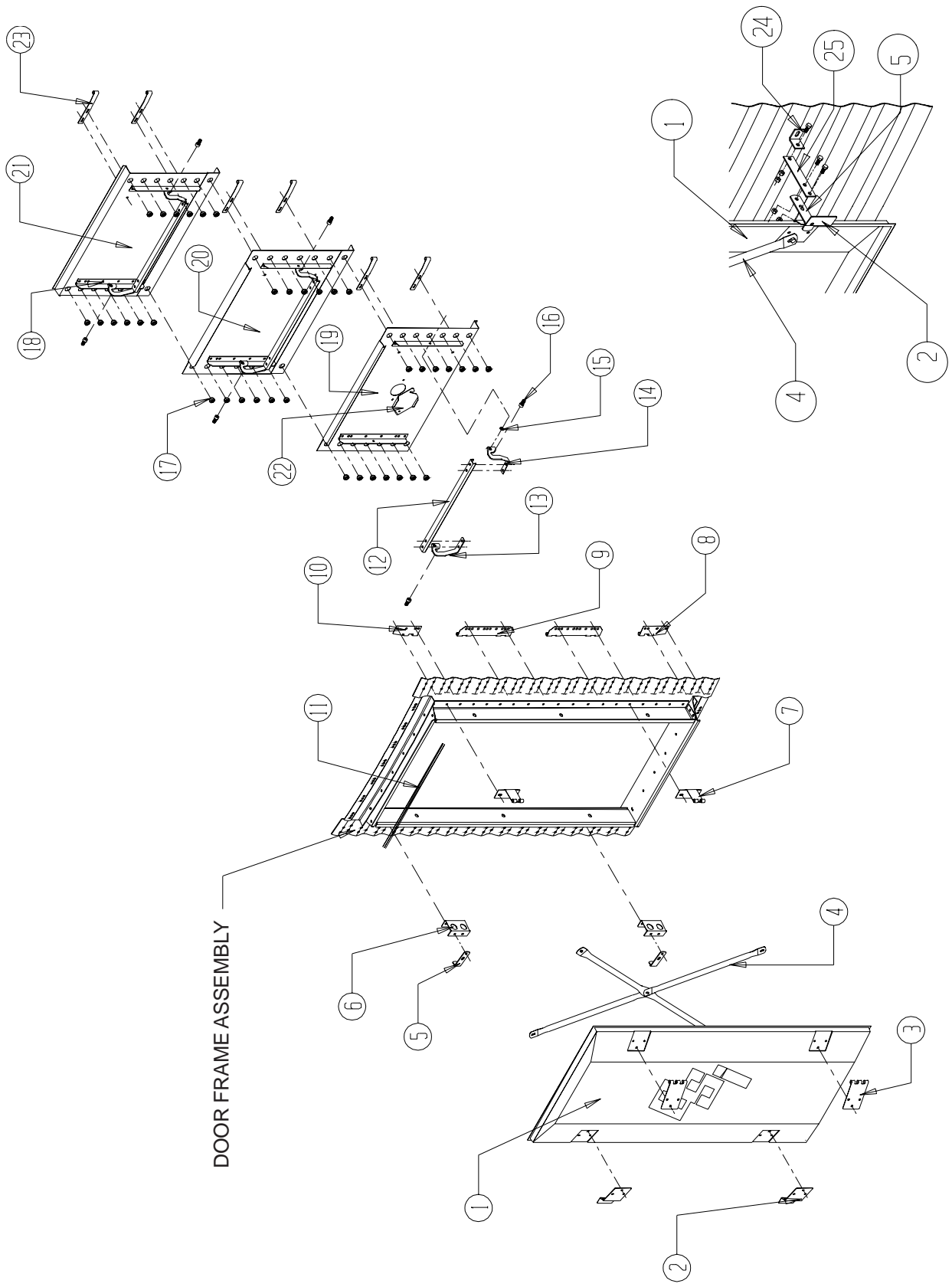

**Figure #74**

- 1.) Remove inner door panels, and outer door cover. Apply double row of rope caulk along door flanges, noting how door and bin sheets lap. The top of the door frame goes to the inside of the sidewall and the bottom of the door frame goes to the outside of the sidewall sheet. With inner door panels and outer door cover removed set door frame into opening. **Insert a bolt at the (4) corners of door frame and sidewall, do not tighten until completing step #2.**
- 2.) Reinstall inner door panels at original locations. Close latch bars to lock panels in place. Be sure that panels are fully seated over all bearing pins. Install inner panel hinge assemblies per illustration instructions with hinges. **Note: do not distort door frame with use of alignment or drift punches - if necessary, drill or ream holes to insert bolts in door frame. Now tighten frame bolts starting at center and working toward top and bottom on each side.**
- 3.) Keep inner panels latched and loosen all bearing pin bolts. Retighten all bearing pin bolts. This makes loading on pins uniform for easier operation of panels.
- 4.) If some latch bars are loose or require excessive force to lock, loosen hex socket capscrews and adjust in or out until latch bars operate smoothly. Check that the panels are fully seated over all bearing pins.
- 5.) Re-install outer cover. Adjust outer door hinges and latches as required.
- 6.) Assemble door hold back as shown on next page. Open door cover until it approaches the bin wall. Hook retaining bracket over lower latch mount and position the door hold back against bin wall in a valley. Drill a 3/8" hole through the bin wall and bolt the door hold back to the bin.



# 2-RING DOOR ASSEMBLY



DOOR HOLD BACK DETAIL

Figure #75

## PARTS LIST FOR 2-RING DOORS

KEY	DESCRIPTION	PART NUMBER		QUANTITY	QUANTITY
		12'-27' BIN DIA. 4.00" CORR.	30'-60' BIN DIA. 4.00" CORR.		
1	OUTER DOOR COVER	WD-039	WD-039	1	1
2	OUTER COVER LATCH BRACKET	WD-2854	WD-2854	2	2
3	OUTER COVER HINGE BRACKET	WD-225	WD-225	2	2
4	DOOR COVER BRACE SECTION	WD-035	WD-035	4	4
5	DOOR RETAINER	WD-033	WD-033	3	3
6	OUTER COVER LATCH MOUNT BASE	WD-6124	WD-6124	2	2
7	OUTER COVER HINGE BASE	WD-6066	WD-6066	2	2
8	BOTTOM INNER DOOR HINGE	WD-6055	WD-6055	1	1
9	MIDDLE INNER DOOR HINGE	WD-6056	WD-6056	2	2
10	TOP INNER DOOR HINGE	WD-6054	WD-6054	1	1
11	RUBBER TRIM SEAL STRIP	S-4380	S-4380	2.1/4 FT.	2.1/4 FT.
12	LATCH BAR	WD-6039	WD-6039	3	3
13	INNER PANEL LATCH - RIGHT HAND	WD-6037	WD-6037	3	3
14	INNER PANEL LATCH - LEFT HAND	WD-6038	WD-6038	3	3
15	1/2" X 1" HEX SOCKET CAPSCREW	S-7160	S-7160	6	6
16	LATCH BUSHING	WD-6040	WD-6040	6	6
17	LONG BEARING PIN	WD-6079	WD-6079	38	38
18	INNER PANEL REINFORCING ANGLE	WD-6125	WD-6125	6	6
19	BOTTOM INNER DOOR PANEL	WD-6128	WD-6128	1	1
20	MIDDLE INNER DOOR PANEL	WD-6127	WD-6127	1	1
21	TOP INNER DOOR PANEL	WD-6126	WD-6126	1	1
22	BOTTOM INNER DOOR PORT HOLE COVER	WD-6028	WD-6028	1	1
23	INNER DOOR HINGE STRAP	WD-6053	WD-6053	6	6
24	DOOR HOLD BACK BRACKET	WD-1302	WD-1302	1	1
25	DOOR HOLD BACK EXTENSION	WD-6110	WD-6110	1	1

---

## OPTIONAL BIN STEP ASSEMBLY

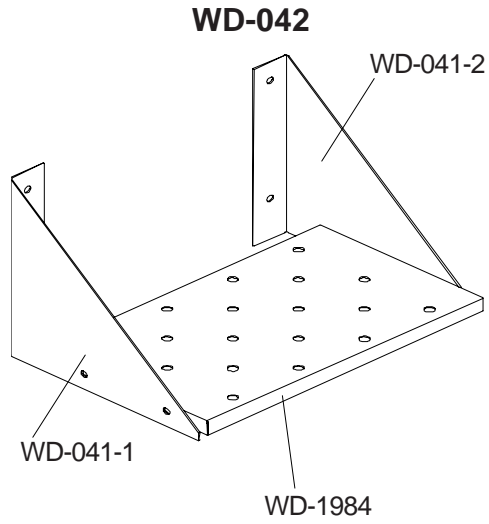

Field drill holes in sidewall sheet on ridge of corrugation.

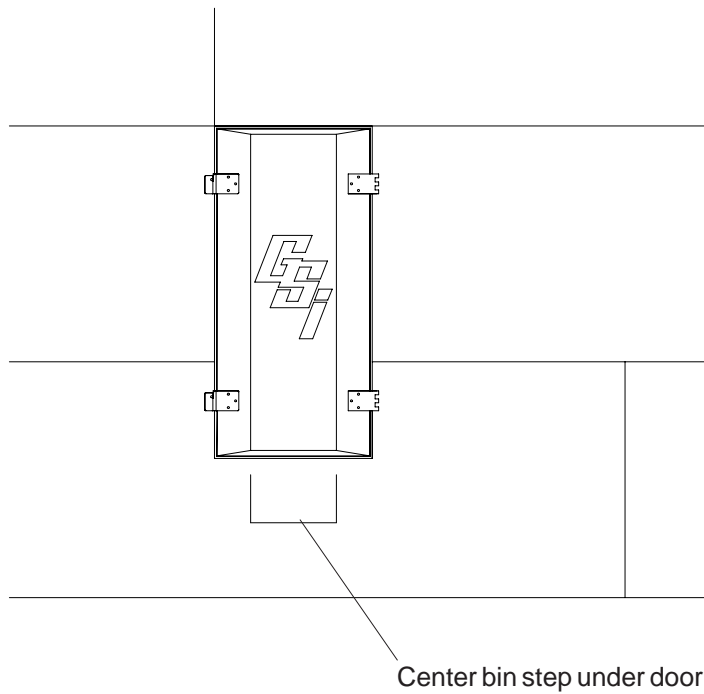

**Figure #76**

## BASE ANGLE

Once the door frame has been placed and secured, continue adding necessary sidewall ring(s). To the lower edge of the bottom ring, attach the base angle ring. Before lowering the bin, apply (optional) mastic sealer to the entire underneath side of the base angle. (See below.) Next, lower the bin on to the foundation and check for an adequate seal.

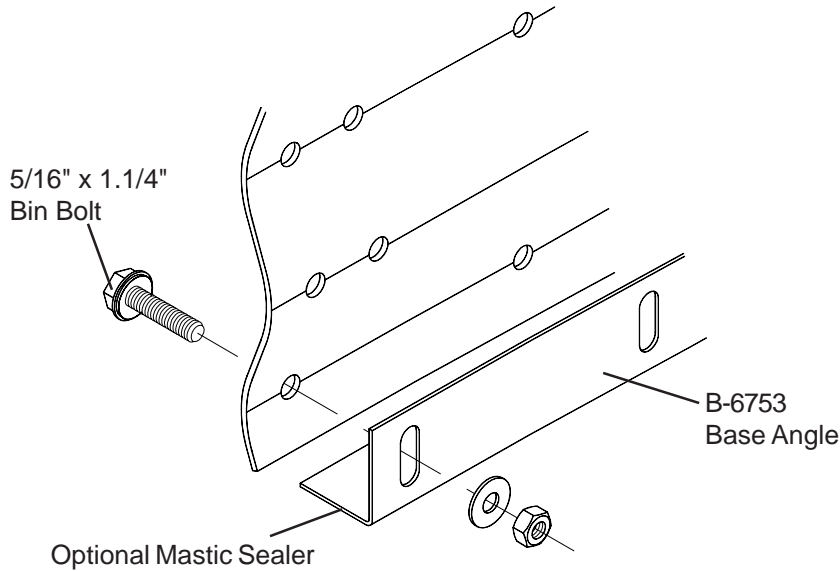

Figure #77

## BASE STIFFENER SHIM

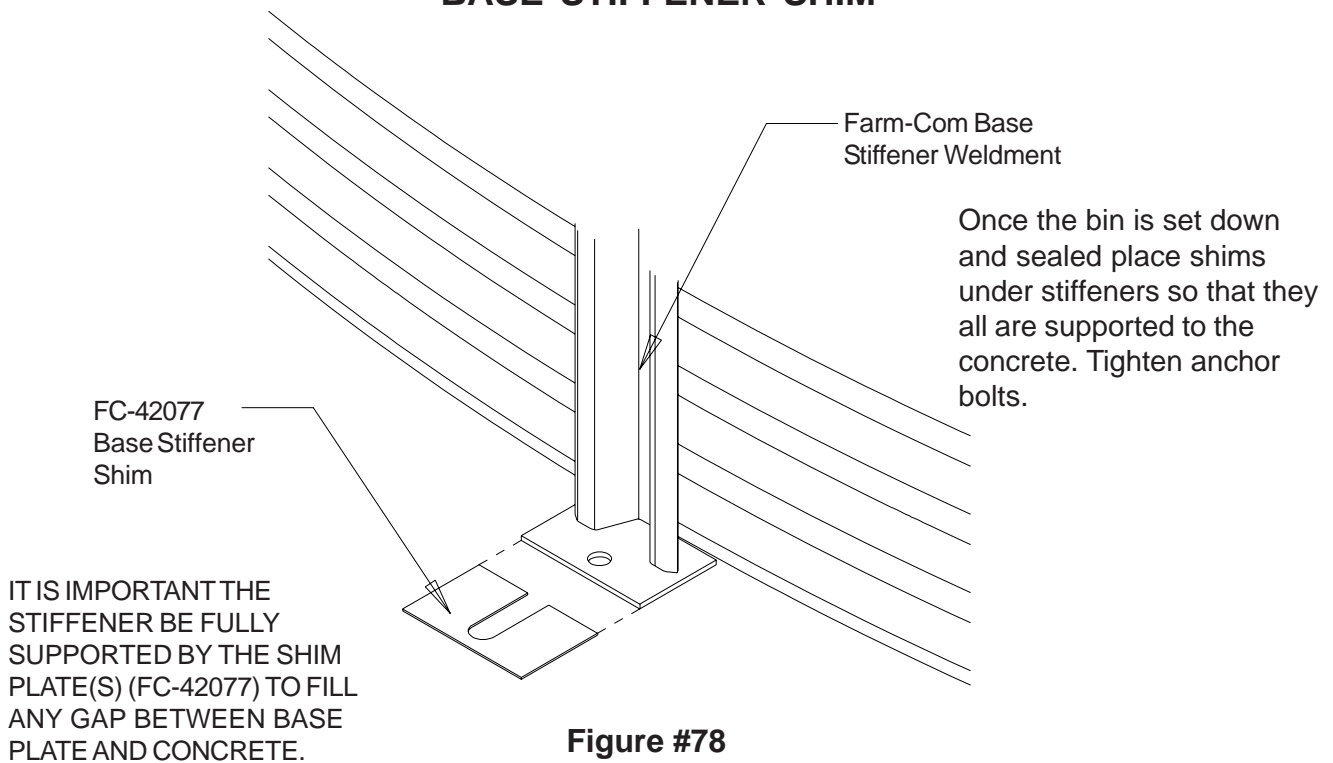

Figure #78

---

## THE GSI GROUP, INC. WARRANTY

THE GSI GROUP, INC. ("GSI") WARRANTS ALL PRODUCTS WHICH IT MANUFACTURES TO BE FREE OF DEFECTS IN MATERIAL AND WORKMANSHIP UNDER NORMAL USAGE AND CONDITIONS FOR A PERIOD OF 12 MONTHS AFTER RETAIL SALE TO THE ORIGINAL END USER. THE PURCHASER'S SOLE REMEDY AND GSI'S ONLY OBLIGATION SHALL BE TO REPAIR OR REPLACE, AT GSI'S OPTION AND EXPENSE, PRODUCTS THAT, IN GSI'S SOLE JUDGMENT, CONTAIN A MATERIAL DEFECT DUE TO MATERIALS OR WORKMANSHIP. ALL DELIVERY AND SHIPMENT CHARGES TO AND FROM GSI'S FACTORY WILL BE PURCHASER'S RESPONSIBILITY. EXPENSES INCURRED BY OR ON BEHALF OF THE PURCHASER WITHOUT PRIOR WRITTEN AUTHORIZATION FROM AN AUTHORIZED EMPLOYEE OF GSI SHALL BE THE SOLE RESPONSIBILITY OF THE PURCHASER.

EXCEPT FOR THE LIMITED WARRANTY EXPRESSED ABOVE, GSI MAKES NO FURTHER WARRANTY OF ANY KIND, EXPRESS OR IMPLIED, INCLUDING, WITHOUT LIMITATION, WARRANTIES OF MERCHANTABILITY OR FITNESS FOR A PARTICULAR PURPOSE OR USE IN CONNECTION WITH (I) PRODUCT MANUFACTURED OR SOLD BY GSI OR (ii) ANY ADVICE, INSTRUCTION, RECOMMENDATION OR SUGGESTION PROVIDED BY AN AGENT, REPRESENTATIVE OR EMPLOYEE OF GSI REGARDING OR RELATED TO THE CONFIGURATION, INSTALLATION, LAYOUT, SUITABILITY FOR A PARTICULAR PURPOSE, OR DESIGN OF SUCH PRODUCTS.

GSI SHALL NOT BE LIABLE FOR ANY DIRECT, INDIRECT, INCIDENTAL OR CONSEQUENTIAL DAMAGES, INCLUDING, WITHOUT LIMITATION, LOSS OF ANTICIPATED PROFITS OR BENEFITS. PURCHASER'S SOLE AND EXCLUSIVE REMEDY IS AS SET FORTH IN THE LIMITED WARRANTY EXPRESSED ABOVE, WHICH SHALL NOT EXCEED THE AMOUNT PAID FOR THE PRODUCT PURCHASED. THIS WARRANTY IS NOT TRANSFERABLE AND APPLIES ONLY TO THE ORIGINAL PURCHASER. GSI SHALL HAVE NO OBLIGATION OR RESPONSIBILITY FOR ANY REPRESENTATIONS OR WARRANTIES MADE BY OR ON BEHALF OF ANY DEALER, AGENT OR DISTRIBUTOR OF GSI.

GSI ASSUMES NO RESPONSIBILITY FOR CLAIMS RESULTING FROM ERECTION DEFECTS OR UNAUTHORIZED MODIFICATIONS TO PRODUCTS WHICH IT MANUFACTURED. MODIFICATIONS TO PRODUCTS NOT SPECIFICALLY DELINEATED IN THE MANUAL ACCOMPANYING THE EQUIPMENT AT INITIAL SALE WILL NULLIFY THE PRODUCT WARRANTY THAT MIGHT HAVE BEEN OTHERWISE AVAILABLE.

THE FOREGOING WARRANTY SHALL NOT EXTEND TO PRODUCTS OR PARTS WHICH HAVE BEEN DAMAGED BY NEGLIGENT USE, MISUSE, ALTERATION OR ACCIDENT. THIS WARRANTY EXTENDS SOLELY TO ONLY PRODUCTS MANUFACTURED BY GSI. THIS WARRANTY IS EXCLUSIVE AND IN LIEU OF ALL OTHER WARRANTIES EXPRESS OR IMPLIED. GSI RESERVES THE RIGHT TO MAKE DESIGN OR SPECIFICATION CHANGES AT ANY TIME.

PRIOR TO INSTALLATION, PURCHASER HAS THE RESPONSIBILITY TO COMPLY WITH ALL FEDERAL, STATE AND LOCAL CODES WHICH MAY APPLY TO THE LOCATION AND INSTALLATION OF PRODUCTS MANUFACTURED OR SOLD BY GSI.

---

This Equipment shall be installed in accordance with the current installation codes and applicable regulations which should be carefully followed in all cases. Authorities having jurisdiction should be consulted before installation occurs.



The GSI Group, Inc.  
1004 E. Illinois St.  
Assumption, IL 62510-0020  
Phone: 217-226-4421  
Fax: 217-226-4420  
e-mail: [gsisales@grainsystems.com](mailto:gsisales@grainsystems.com)  
internet: <http://www.grainsystems.com>