

Air Diffuser Instructions

AutoFlow Top Dry
42" Fan

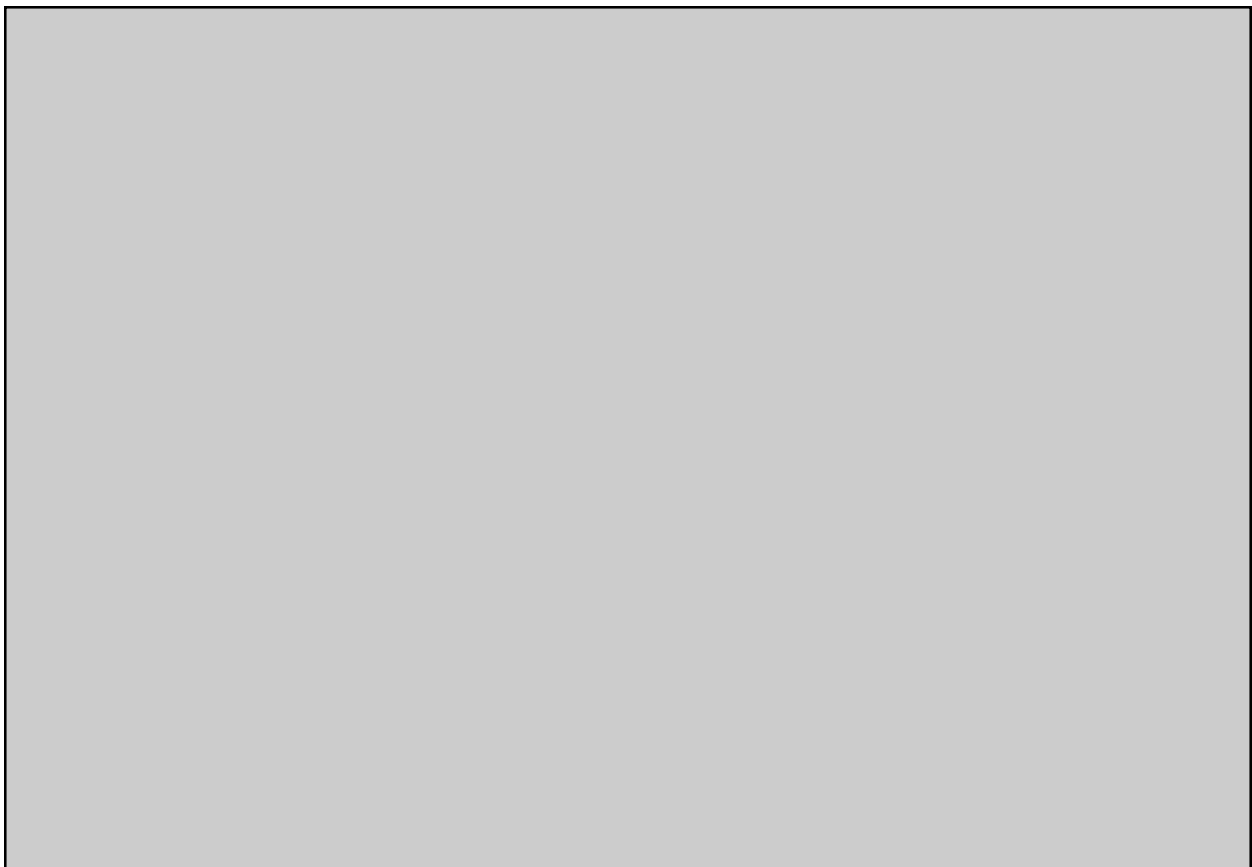

1. Mark and drill one 3/8" hole in the center of long side of each diffuser hanger. Mark and drill two 3/8" holes in the short side of each hanger.
2. Bolt the long side of the hangers to the endmost slots of the top plate (TD-100665) as shown below.
3. Hold the top plate up under the bottom flange of the "C" channel in front of the fan opening. Mark and drill four 3/8" holes into bottom flange using diffuser hangers as a guide. Using 5/16" x 3/8" bolts and nuts bolt the top plate to the "C" channel.

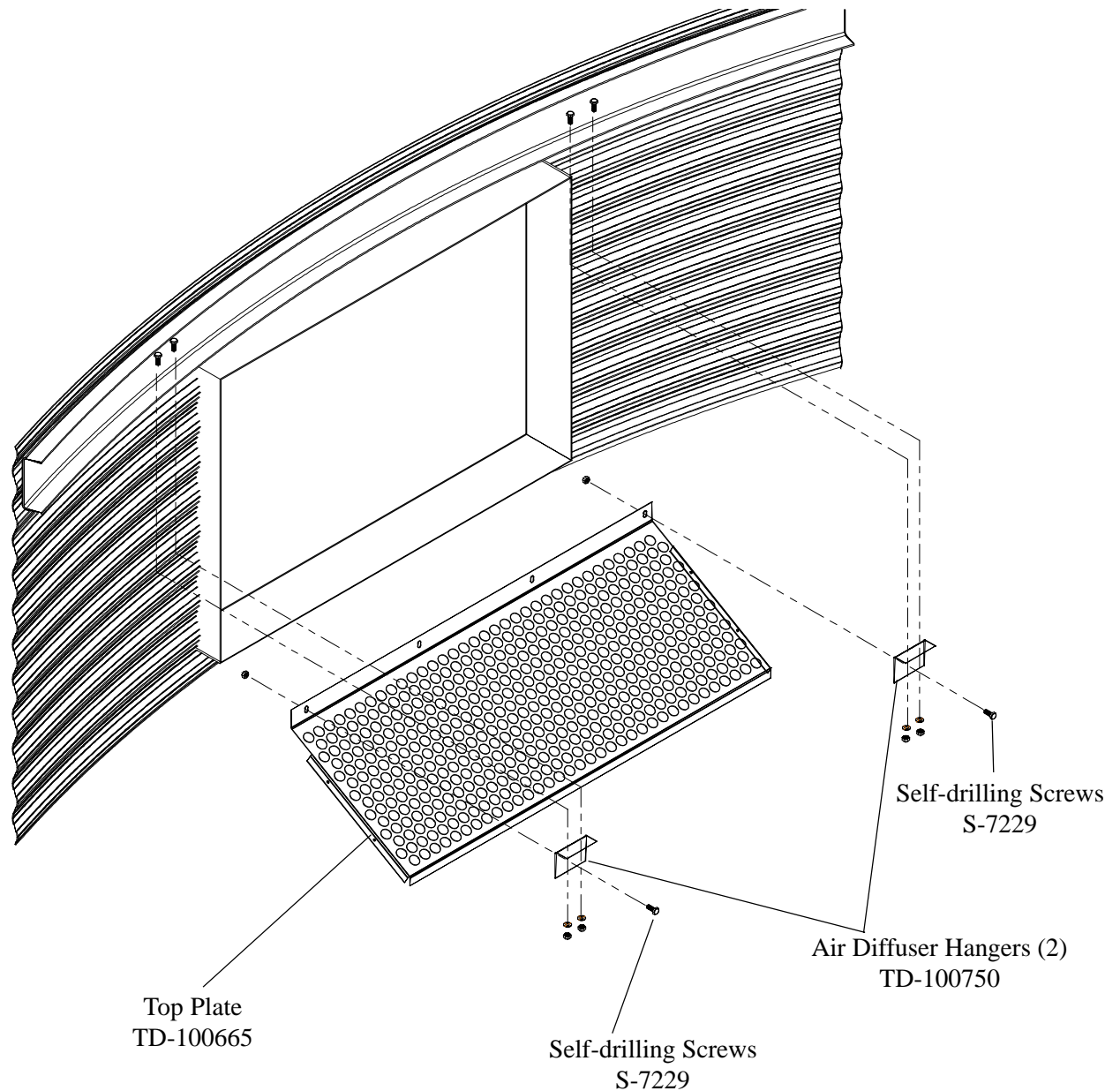

4. Attach front plate to the top plate with four 1/4" x 1" self-drilling screws.
5. Bolt the side brackets in the front plate slot with the angles outward. Field drill two holes (on inside corrugation hills) through the sidewall and install 5/16" x 3/4" bin bolts and nuts.
6. Position the side plates on each side with the angle outward and fasten in place using six 1/4" x 1" self-drilling screws.

NOTE: The corner bolt will need to be removed and reinstalled through the side plate, side bracket and front plate.

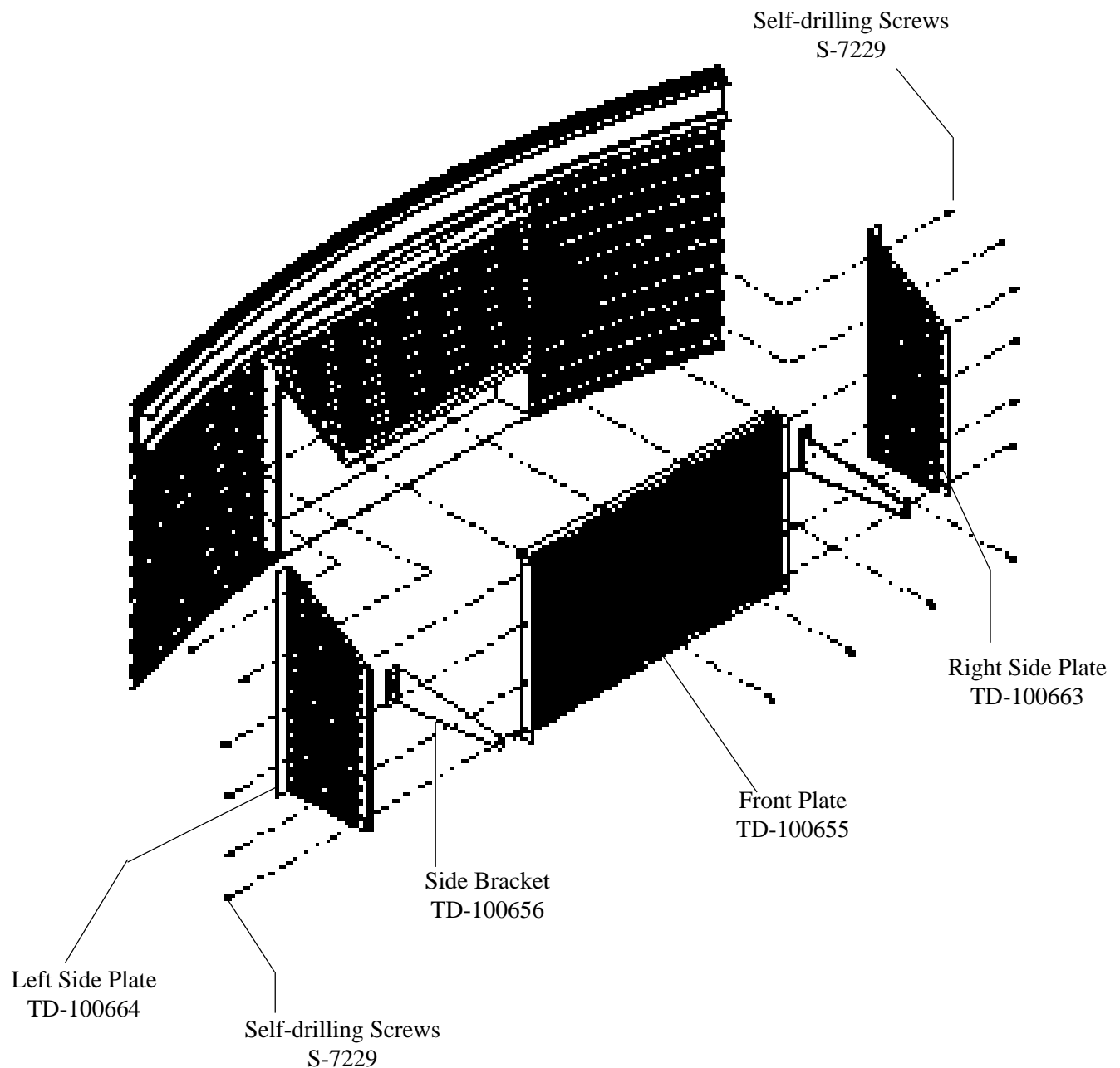



Grain Systems Inc., • 1004 E. Illinios St. • Assumption, Il 62510 • (217) 226-4421
11/1/94