



TopDry Batch Control Terminal™

Models:

24, 30, 36 FT. DIAMETER

Operation Manual

PNEG-4902

Version 1.2

Date: 09-27-20



PNEG-4902

All information, illustrations, photos, and specifications in this manual are based on the latest information available at the time of publication. The right is reserved to make changes at any time without notice.

Contents

Chapter 1	Safety Precautions	5
	Safety Guidelines	5
	Cautionary Symbol Definitions.....	6
	Safety Cautions.....	7
	Safety Decals	15
	Safety Sign-off Sheet.....	19
Chapter 2	The TopDry™ System	21
	Overview of the TopDry Grain Dryer.....	21
	Location of TopDry Components and Accessories	22
	TopDry Batch Terminal Drying Capacities.....	24
	Storage Capacity	25
Chapter 3	Gas and Electrical Specifications	27
	The Fuel Supply	27
	Electrical Load Information.....	28
Chapter 4	Control Panels	29
	The TopDry Batch Terminal Control Panel	30
	Powering on the Touchscreen	32
	Overview of the User Interface	32
	Configuring the Operational Settings for the TopDry Batch Terminal	34
	The Timer Menu.....	36
	Setting the Timers	37
	The Temperature Menu	38
	Setting the Temperature Limits	38
	Setting the Temperature Setpoints for the Plenum and Grain from the Main Screen.....	39
	The Information Menu.....	41
	Factory Default Settings.....	42
Chapter 5	Getting Started	43
	Pre-Season Inspections.....	43
	Testing the Dump Chutes.....	44
	Testing the Air Switch	45
	Testing the Burner	46
Chapter 6	Operation	47
	Shutting OFF the Dryer in an Emergency	47
	Initial Dryer Start-Up	48
	Shutting OFF the Dryer.....	48
Chapter 7	Troubleshooting	49
	TopDry Batch Terminal Error Messages	49
Chapter 8	Wiring Diagrams	51
	GSI Group, LLC Limited Warranty	63

NOTES

1 Safety Precautions

Topics Covered in this Chapter

- Safety Guidelines
- Cautionary Symbol Definitions
- Safety Cautions
- Safety Decals
- Safety Sign-off Sheet

Safety Guidelines

Safety guidelines are general-to-specific safety rules that must be followed at all times. This manual is written to help you understand safe operating procedures and problems that can be encountered by the operator and other personnel when using this equipment. Save these safety guidelines for future reference.

As owner or operator, you are responsible for understanding the requirements, hazards, and precautions that exist and to inform others as required. Unqualified persons must stay out of the work area at all times.

Alterations must not be made to the equipment. Alterations can produce dangerous situations resulting in **SERIOUS INJURY** or **DEATH**.

This equipment must be installed in accordance with the current installation codes and applicable regulations, which must be carefully followed in all cases. Authorities having jurisdiction must be consulted before installations are made.

When necessary, you must consider the installation location relative to electrical, fuel and water utilities.







Personnel operating or working around equipment must read this manual. This manual must be delivered with equipment to its owner. Failure to read this manual and its safety instructions is a misuse of the equipment.

ST-0001-3

Cautionary Symbol Definitions

Cautionary symbols appear in this manual and on product decals. The symbols alert the user of potential safety hazards, prohibited activities and mandatory actions. To help you recognize this information, we use the symbols that are defined below.

Table 1-1 Description of the different cautionary symbols

Symbol	Description
	This symbol indicates an imminently hazardous situation which, if not avoided, will result in serious injury or death.
	This symbol indicates a potentially hazardous situation which, if not avoided, can result in serious injury or death.
	This symbol indicates a potentially hazardous situation which, if not avoided, can result in minor or moderate injury.
	This symbol is used to address practices not related to personal injury.
	This symbol indicates a general hazard.
	This symbol indicates a prohibited activity.
	This symbol indicates a mandatory action.

ST-0005-2

Safety Cautions

Use Personal Protective Equipment

- Use appropriate personal protective equipment:

Eye Protection



Respiratory Protection



Foot Protection



Hearing Protection



Head Protection



Fall Protection



Hand Protection



- Wear clothing appropriate to the job.
- Remove all jewelry.
- Tie long hair up and back.

ST-0004-1

Follow Safety Instructions

- Warning:** If the information in the manual is not followed exactly, a fire or explosion can result, causing property damage, personal injury or loss of life.
- Carefully read all safety messages in this manual and safety signs on your machine. Keep signs in good condition. Replace missing or damaged safety signs. Be sure new equipment components and repair parts include the current safety signs. Replacement safety signs are available from the manufacturer.
- Learn how to operate the machine and how to use controls properly. Do not let anyone operate without instruction.
- If you do not understand any part of this manual or need assistance, contact your dealer.
- Retain these instructions for future reference.



ST-0025-3

Chapter 1: Safety Precautions

Install and Operate Equipment Properly

- Make sure grain chutes are empty by performing a manual dump before entering the bin.
- Before attempting to remove and reinstall the fan blade, contact GSI for the recommended procedure.



ST-0031-2

For Your Safety

- If you smell gas:
 - Do not try to light any appliance.
 - Extinguish any open flames.
 - Do not touch any electrical switch.
 - Immediately call your gas supplier. Follow the gas supplier's instructions.
 - If you cannot reach your gas supplier, call the fire department.
- The use and storage of gasoline and other flammable vapors and liquids in open containers in the vicinity of this appliance is hazardous.
- Improper installation, adjustment, alteration, service or maintenance can cause property damage, injury or death. Read the installation, operating and maintenance instructions thoroughly before installing or servicing this equipment. Installation and service must be performed by a qualified installer, service agency or the gas supplier.



ST-0024-1

Install and Operate Electrical Equipment Properly

- Electrical controls must be installed by a qualified electrician and must meet the standards set by applicable local codes (National Electrical Code for the US, Canadian Electric Code, or EN60204 along with applicable European Directives for Europe).
- Lock-out power source before making adjustments, cleaning, or maintaining equipment.
- Make sure all equipment is properly grounded.



ST-0027-4

Handle and Use Equipment Properly

- Equipment is intended for the use of grain drying only. Any other use is a misuse of this equipment.
- The operating instructions in this manual pertain to the common cereal grains as indicated. When drying any other grain, contact GSI for additional recommendations.
- On LP fired units, set pressure regulator to avoid excessive gas pressure applied to the burner during ignition and operation. Do not exceed maximum recommended drying temperatures.
- Equipment has sharp edges that can cause serious injury. To avoid injury, handle sharp edges with caution and use proper protective clothing and equipment at all times.
- All guards must be in place before and during operation. Images of guards removed in this manual are for illustration purposes only.
- Use caution when working around high-speed fans, gas burners, augers and auxiliary conveyors which can start automatically.
- Keep hands, feet, and clothing away from moving parts.
- Do not bypass any safety device or interlock.
- Do not enter the dryer or bin while it is operating.
- Do not operate in an area where combustible material will be drawn into the dryer.



ST-0029-2

Exercise Caution When Drying Flammable Grains

- Be aware that some grains are highly flammable including, but not limited to, rapeseed, canola, linseed, sunflower and milo.
- All grain and seed must be whole (minimal cracking or crushing), clean, and dust free before drying.
- Avoid dust and chaff from being drawn into the fan and heater.
- To reduce risk of fire, keep the fan, heater, drying plenum, and ducts clean at all times.
- In the event of a fire (or suspected fire):
 1. Shut down the entire dryer.
 2. Turn off the fuel at the tank or supply valve.
 3. Shut off and lock electrical power.
 4. Evacuate the area.
 5. Call the fire department.



ST-0032-1

Install and Operate Gas-Fired Equipment Properly

- Gas-fired equipment should be installed by a qualified pipe fitter and must conform with local codes.
- For Canada: The equipment shall be installed in accordance with the *Natural Gas and Propane Installation Code, CSA B149.1*, or the *Propane Storage and Handling Code, CSA B149.2*, or applicable provincial regulations, which should be carefully followed in all cases. Authorities having jurisdiction should be consulted before installations are made.
- For the United States: The equipment shall be installed in accordance with the *National Fuel Gas Code ANSI Z223.1/ NFPA 54*.



ST-0016-2

Prevent Roof Damage Due to Vacuum Pressure

- Roof damage can result from excessive vacuum or internal pressure from fans or other air moving systems. The manufacturer does not warrant this type of roof damage.
- Adequate ventilation or “makeup air” devices must be provided for all powered air handling systems.
- The manufacturer does not recommend the use of downward flow systems (suction).
- Severe roof damage can result from any blockage of air passages.
- Operating fans during high humidity or cold weather conditions can cause air exhaust or intake ports to freeze.

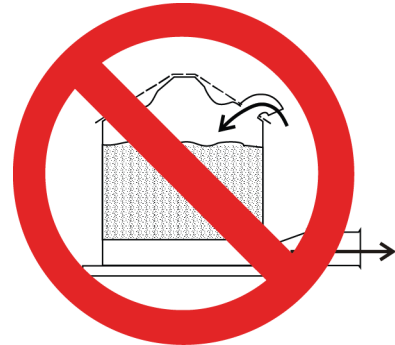

ST-0028-2

Maintain Equipment and Work Area

- Understand service procedures before doing work.
- Keep area clean and dry.
- Do not service equipment while it is operating. Disconnect and lock-out power and fuel supply before entering equipment or before performing maintenance.
- Keep your equipment in proper working condition. Replace worn or broken parts immediately.
- Depressurize the fuel train before disassembling for service.
- Allow the fan to operate for 20 minutes with the burner off to purge products of combustion and to cool the components before entering.
- Check regularly for any developing gas plumbing leaks. Do not operate the dryer if any gas leak is detected. Shut down and repair before further operation.



ST-0030-2

Chapter 1: Safety Precautions

Store Bin Sheets Properly

- Sidewall bundles or sheets must be stored in a safe manner. The safest method of storing sidewall bundles is by laying them horizontally with the arch of the sheet upward, like a dome.
- Sidewall sheets stored on edge must be secured so that they cannot fall over and cause injury.
- Use care when handling and moving sidewall bundles.



ST-0058-1

Rotating Auger Hazard

- Keep clear of rotating augers and moving parts.
- Do not remove or modify guards or covers.
- Lock-out power source before making adjustments, cleaning, or maintaining equipment.
- Failure to follow these precautions will result in serious injury or death.



ST-0037-1

Stay Clear of Hoisted Equipment

- Always use proper lifting or hoisting equipment when assembling or disassembling equipment.
- Do not walk or stand under hoisted equipment.
- Always use sturdy and stable supports when needed for installation. Not following these safety precautions creates the risk of falling equipment, which can crush personnel and cause serious injury or death.



ST-0047-1

Confined Space Hazards and Entry Procedures

- Note that the interior of this equipment is considered a confined space. Maintenance of this equipment can require access to the confined space.
- Access doors must be shut and locked except when access is required.
- Doors giving access to dangerous equipment must be safety interlocked.
- The following entry procedures must be followed:
 - Be aware of all possible hazards present inside the confined space and wear personal protective equipment (PPE) as needed.
 - Complete a permit to work and follow all permit required confined space entry procedures defined by the site manager.
 - Make sure that the area has been purged of any hazardous products or gases. Check the atmosphere for harmful gases or vapors with a suitable gas analyzer and make sure levels are safe before entering.
 - Do not smoke or use naked flames.
 - Lock out and tag out power supplies and fuel supplies to all equipment.
 - Do not work alone. Work in teams of at least three so that help is immediately available in the event of an emergency.
 - Confirm that all personnel have safely exited the equipment and tools have been recovered once work is complete.



ST-0055-1

Chapter 1: Safety Precautions

Fall Hazard

- Ladders, stairways and platforms are for use by competent and trained personnel only. Do not allow children or other unauthorized persons to have access to the equipment.
- Access to the equipment must be restricted by the use of security fencing and lockable gates.
- Lower sections of ladders must be fitted with a lockable safety gate to prevent unauthorized access.
- Make sure that hot surfaces have had adequate time to cool before working on or in the equipment.
- Lock out and tag out power supplies and fuel supplies to all equipment.
- Do not attach lifting equipment to ladders or platforms.
- Do not go outside of the safety rails provided on elevated platforms.
- Do not work at heights during high winds, rain, snow, or ice storms.



ST-0056-1

Unload the Bin Correctly

- Use CENTER FLOOR OUTLET ONLY until NO grain remains above this outlet.
- Side floor outlets to be used ONLY when above condition is satisfied.
- Lock all side floor outlets to avoid accidental premature use.
- See manufacturers instructions for proper use of factory supplied sidedraw (wall) discharge systems.

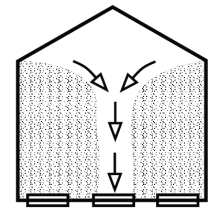
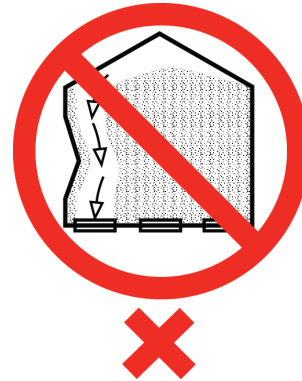

ST-0060-1

Do Not Overfill TopDry

- Do not overfill TopDry. Stored grain must be no higher than the heater duct opening.
- Filling the bin above this point will cause a blockage of the ducts.

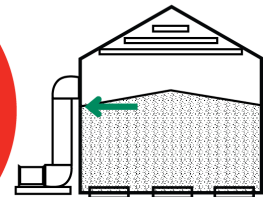
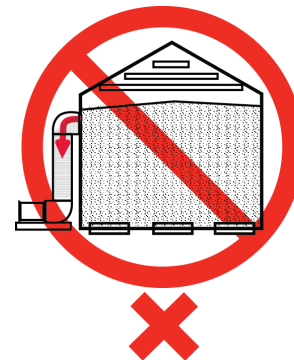

ST-0062-1

Safety Decals

The safety decals on your equipment are safety indicators which must be carefully read and understood by all personnel involved in the installation, operation, service and maintenance of the equipment.

To replace a damaged or missing decal, contact us to receive a free replacement.



GSI Decals

1004 E. Illinois Street
 Assumption, IL 62510
 Phone: 1-217-226-4421

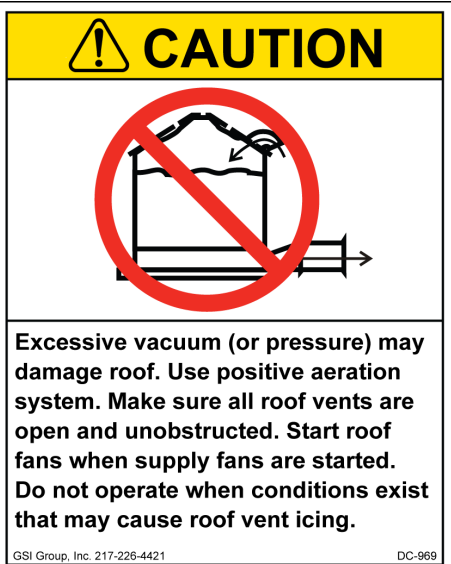



Bin Decals

Location	Decal No.	Decal	Description
Located next to aeration system.	DC-995	 <p>Excessive vacuum (or pressure) may damage roof. Use positive aeration system. Make sure all roof vents are open and unobstructed. Start roof fans when supply fans are started. Do not operate when conditions exist that may cause roof vent icing.</p> <p>GSI Group, Inc. 217-226-4421 DC-969</p>	Caution Vacuum Pressure



Chapter 1: Safety Precautions

Location	Decal No.	Decal	Description
On bin door covers	DC-GBC-1A	 <p>! DANGER</p> <p>Rotating flighting will kill or dismember. Flowing material will trap and suffocate. Crusted material will collapse and suffocate.</p> <p>Keep clear of all augers. DO NOT ENTER this bin!</p> <p>If you must enter the bin:</p> <ol style="list-style-type: none"> 1. Shut off and lock out all power. 2. Use a safety harness and safety line. 3. Station another person outside the bin. 4. Avoid the center of the bin. 5. Wear proper breathing equipment or respirator. <p>Failure to heed these warnings will result in serious injury or death.</p> <p><small>GSI GROUP, INC. 217-226-4421 DC-GBC-1A</small></p>	Danger Keep Clear of Augers
On bin door covers	DC-GBC-2A	 <p>! WARNING</p> <p>UNLOADING INSTRUCTIONS:</p> <ol style="list-style-type: none"> 1. Use CENTER FLOOR OUTLET ONLY until NO grain remains above this outlet. 2. Side floor outlets to be used ONLY when above condition is satisfied. 3. Lock all side floor outlets to avoid accidental premature use. 4. See manufacturers instructions for proper use of factory supplied sidedraw (wall) discharge systems. <p>Failure to heed these warnings could result in serious injury, death, structural damage or collapse of tank.</p> <p><small>GSI GROUP, INC. 217-226-4421 DC-GBC-2A</small></p>	Warning Unload Instructions

Fan and Heater Decals

Location	Decal No.	Decal		Description	
Fan and Heater Unit	DC-1943	<p>⚠ DANGER HIGH VOLTAGE.</p> <p>Will cause injury or death.</p> <p>Lockout power before servicing.</p> <p><small>GSI Group 217-226-4421</small></p>		<p>⚠ DANGER HAUTE TENSION.</p> <p>Causera des blessures ou la mort.</p> <p>Bloquez le courant avant de faire l'entretien.</p> <p><small>DC-1943</small></p>	High Voltage Danger Decal
Fan and Heater Unit	DC-1948	<p>⚠ DANGER HIGH VOLTAGE</p> <p>Will cause serious injury or death.</p> <p>Lockout power before servicing.</p> <p><small>GSI Group 217-226-4421</small></p>		<p>⚠ DANGER HAUTE TENSION</p> <p>Causera de sérieuses blessures ou la mort.</p> <p>Couper/verrouiller le courant avant l'entretien.</p> <p><small>DC-1948</small></p>	High Voltage Danger Decal
Fan and Heater Unit	DC-1949	<p>⚠ WARNING</p> <p>Stay clear of rotating blade. Blade could start automatically. Can cause serious injury. Disconnect power before servicing.</p> <p><small>GSI Group Inc. 217-226-4421</small></p>		<p>⚠ AVERTISSEMENT</p> <p>Restez éloigné de la lame tournante. La lame peut se mettre en marche automatiquement. Peut causer de sérieuses blessures. Verrouillez le courant avant l'entretien.</p> <p><small>DC-1949</small></p>	Rotating Blade Warning Decal
Fan and Heater Unit	DC-1959	<p>⚠ WARNING</p> <p>Flame and pressure beyond door can cause serious injury. Do not operate with service door removed. Keep head and hands clear.</p> <p><small>GSI Group 217-226-4421</small></p>		<p>⚠ AVERTISSEMENT</p> <p>La flamme et la pression au-delà de la porte peuvent causer des dommages sérieux. Ne pas faire fonctionner si la porte de service est enlevée. Gardez les mains et la tête éloignés.</p> <p><small>DC-1959</small></p>	Flame and Pressure Warning Decal
Fan and Heater Unit	DC-2330	<p>⚠ WARNING</p> <p>Improper installation, adjustment, alteration, service or maintenance can cause property damage, injury or death. Read the installation, operating and maintenance instructions thoroughly before installing or servicing this equipment.</p> <p><small>GSI Group 217-226-4421</small></p>		<p>⚠ AVERTISSEMENT</p> <p>Une installation, un réglage, une modification, un entretien ou une réparation incorrects peuvent entraîner des dommages, des blessures, voire la mort. Lisez attentivement les instructions d'installation, d'opération et d'entretien avant d'installer ou de réparer cet équipement.</p> <p><small>DC-2330</small></p>	Read Manual Warning Decal

Chapter 1: Safety Precautions

Location	Decal No.	Decal		Description	
Fan and Heater Unit	DC-2331	<p>⚠ WARNING</p> <p>The use and storage of gasoline and other flammable vapors and liquids in open containers in the vicinity of this appliance is hazardous.</p> <p><small>GSI Group 217-226-4421</small></p>		<p>⚠ AVERTISSEMENT</p> <p>Il est dangereux d'utiliser ou de stocker de l'essence ou tout autre liquide ou vapeur inflammables dans des contenants ouverts à proximité de cet appareil.</p> <p><small>DC-2331</small></p>	Flammable Vapor Warning Decal
Fan and Heater Unit	DC-2392	<p>⚠ WARNING</p> <p>If the information in the manual is not followed exactly, a fire or explosion may result causing property damage, personal injury or loss of life.</p> <p>Do not store or use gasoline or other flammable vapours and liquids in the vicinity of this or any other appliance.</p> <p>What to do if you smell gas</p> <ul style="list-style-type: none"> - Do not try to light any appliance. - Extinguish any open flames. - Do not touch any electrical switch. - Immediately call your gas supplier. <p>Follow the gas supplier's instructions.</p> <ul style="list-style-type: none"> - If you cannot reach your gas supplier, call the fire department. <p>Installation and service must be performed by a qualified installer, service agency or the gas supplier.</p> <p><small>GSI Group 217-226-4421</small></p>	 	<p>⚠ AVERTISSEMENT</p> <p>Si les directives du manuel ne sont pas suivies à la lettre, une explosion ou un incendie pourrait survenir et causer des dommages à la propriété, des blessures corporelles voire même la mort.</p> <p>N'entreposez pas et n'utilisez pas d'essence ni d'autres vapeurs et liquides inflammables près de cet appareil ou de tout autre appareil.</p> <p>Que faire en présence d'une odeur de gaz.</p> <ul style="list-style-type: none"> - N'essayez pas d'allumer un autre appareil - Éteignez toute flamme découverte - Ne touchez à aucun interrupteur électrique - Contactez immédiatement votre fournisseur de gaz. Suivez les instructions du fournisseur de gaz. - Si vous n'êtes pas en mesure de joindre votre fournisseur de gaz, appelez les pompiers <p>L'installation et l'entretien doivent être effectués par un installateur qualifié, une agence spécialisée en entretien ou le fournisseur de gaz.</p> <p><small>DC-2392</small></p>	Flammable Vapor Warning Decal

NOTES

2 The TopDry™ System

Topics Covered in this Chapter

- Overview of the TopDry Grain Dryer
- Location of TopDry Components and Accessories
- TopDry Batch Terminal Drying Capacities
- Storage Capacity

Overview of the TopDry Grain Dryer

The TopDry Grain Dryer is a grain bin with the addition of a peaked drying floor inside the top of the bin. The grain flows into the top of the bin and special leveling bands keep the grain at a uniform depth. A large fan and heater unit, located on the ground, heat the grain located in the overhead drying chamber via ductwork. Once dried, the grain is dumped into the holding area below for storage. A smaller aeration fan cools the grain and captures heat from the previously dried grain and pushes it upward to help dry the next load.

Figure 2-1 TopDry grain dryer installation



CTPBF000OP18001

Location of TopDry Components and Accessories

Use the following as a suggested guideline for placing the TopDry components and accessories.

When locating the manway, make sure that the outside ladder will not interfere with other accessories below. Roof vents must be spaced evenly around the roof. (Quantity will vary with individual systems.)

- IMPORTANT:**
1. Items (6), (8) and (10) must be in this location between the first two stiffeners to the right of the fan for proper operation.
 2. Items (6) and (8) must be at platform or an optional ladder and platform will be required.
 3. Aeration fan must not be placed within 90 degrees of a fan or burner.
 4. Storage chamber rotary switch must be mounted 3 ft. below fan/heater duct opening.
 5. TopDry Batch Terminal (12) can be remote mounted or mounted to the dryer.

Figure 2-2 Location of TopDry Components and Accessories - Top View

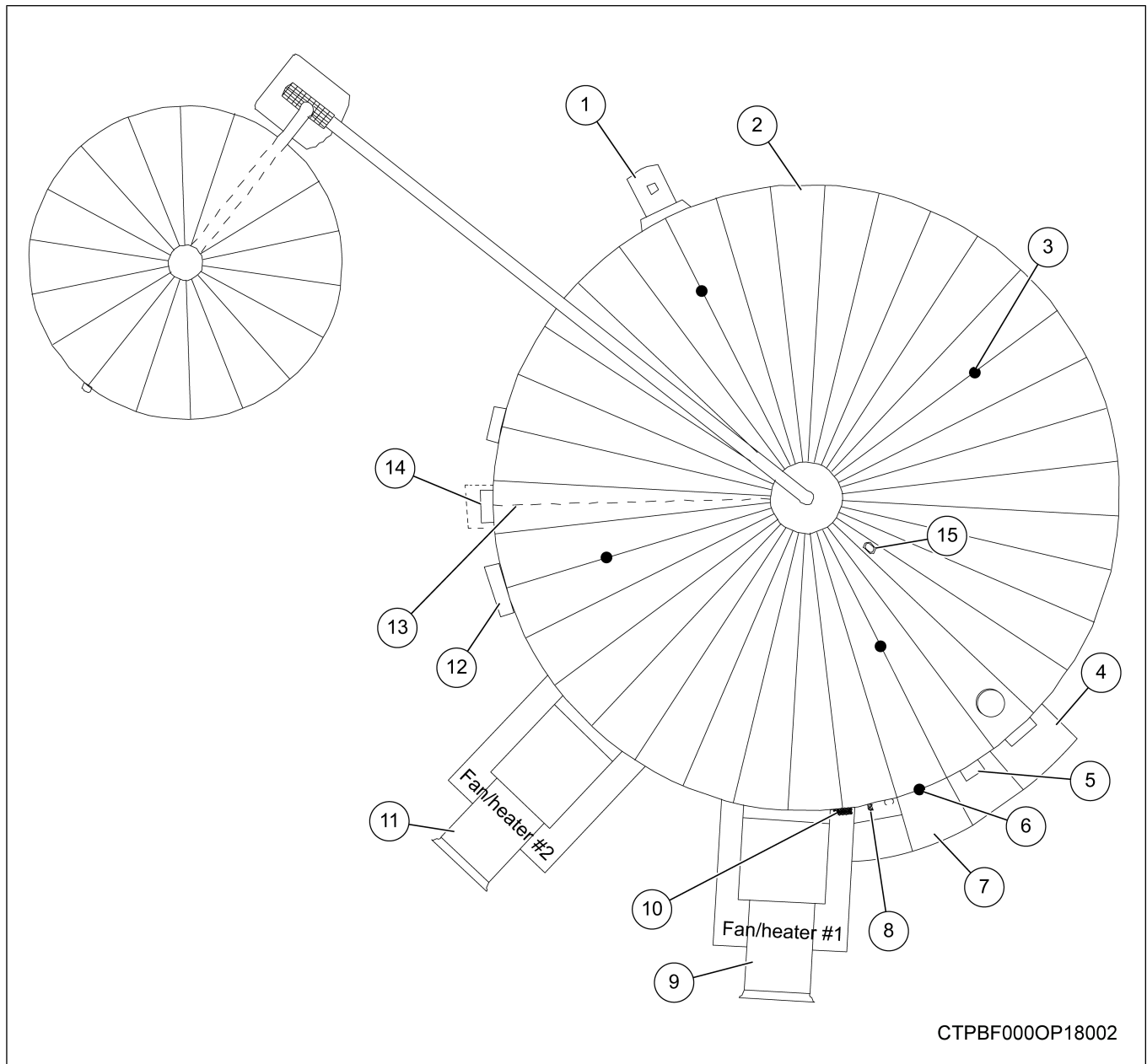
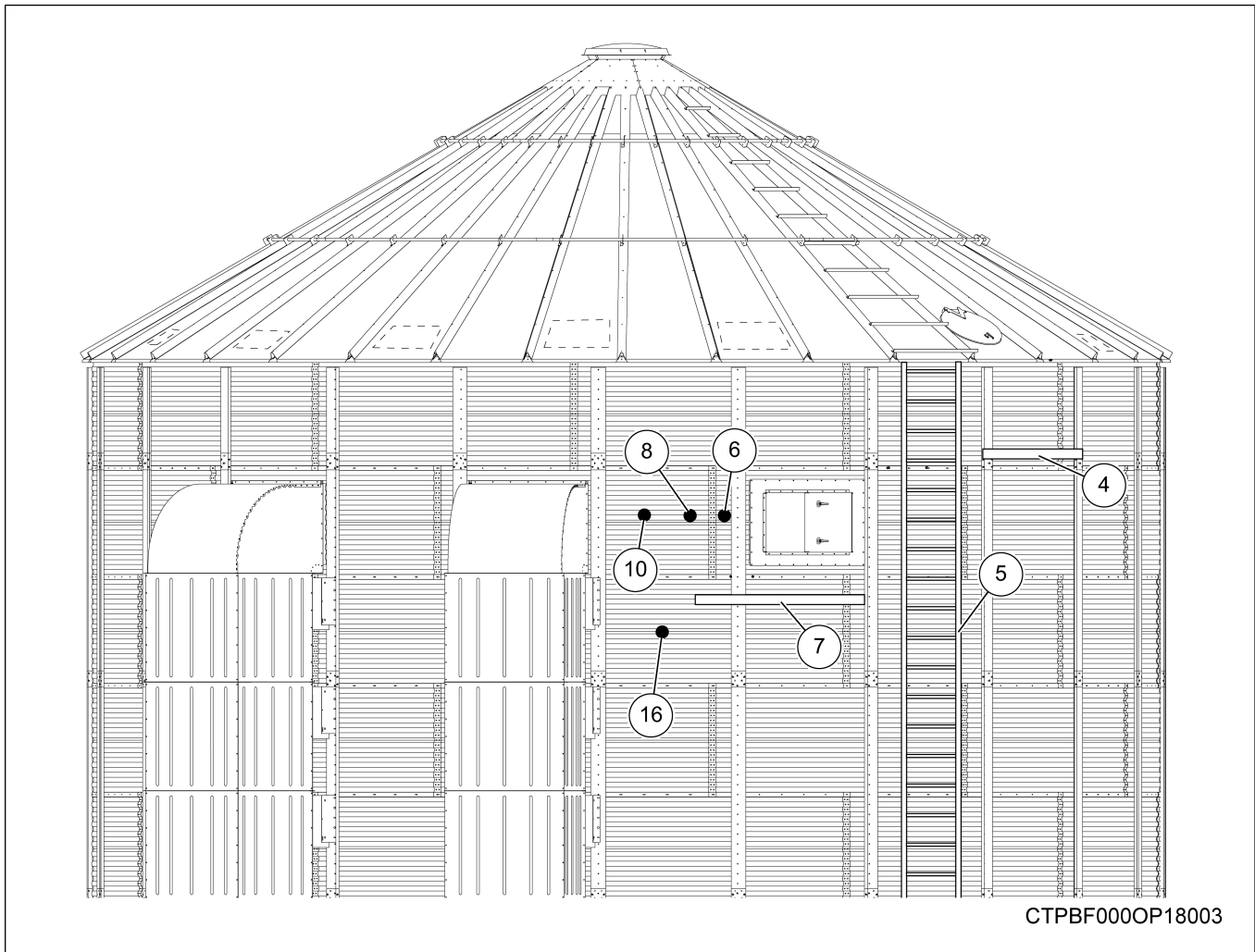

Figure 2-3 Location of TopDry Components and Accessories - Side View



1	Aeration fan ¹	9	Control fan/heater
2	TopDry drying bin	10	Plenum temperature sensor ²
3	Grain temperature sensors	11	Fan/Heater (Secondary)
4	Eave platform	12	TopDry Batch Terminal
5	Ladder	13	Cable route
6	Plenum high limit sensor ²³	14	Winch
7	Storage chamber platform	15	Overflow sensor
8	Grain temperature sensor junction box ²³	16	Storage chamber overflow sensor

1. Must not be placed within 90 degrees of a fan or burner.
2. Must be in this location between the first two stiffeners to the right of the fan for proper operation.
3. Must be at platform or optional ladder and platform will be required.

TopDry Batch Terminal Drying Capacities

Table 2-1 Drying Rates for Shelled Corn

TopDry Batch Terminal Series			24' Dia. 1-Fan		30' Dia. 1-Fan		30' Dia. 2-Fan		36' Dia. 1-Fan		36' Dia. 2-Fan	
Fan & Heater Unit(s)	Plenum Temp.	Moisture Content Wet Basis	BPH	Dump Interval Min	BPH	Dump Interval Min	BPH	Dump Interval Min	BPH	Dump Interval Min	BPH	Dump Interval Min
15 H.P. 36" Fan 3.5 million BTU	160° F	20%	528	21.6	557	31.9	939	18.9			993	19.4
		25%	334	34.1	353	50.4	595	29.9			629	30.6
		30%	209	54.6	220	80.8	371	47.9			393	49
	180° F	20%	675*	16.8*	713*	24.9*	1202	14.8			1271	15.1
		25%	428*	26.6*	451*	39.4*	761	23.4			805	23.9
		30%	267*	42.6*	282*	63.1*	475	37.4			503	38.3
	200° F	20%	791*	14.4*	835*	21.3*	1407*	12.6*			1488*	12.9*
		25%	501*	22.7*	529*	33.6*	891*	19.9*			943*	20.4*
		30%	313*	36.4*	330*	53.9*	557*	32.0*			589*	32.7*
15 H.P. 40" Fan 6.25 million BTU	160° F	20%	648	17.5	711	25	1154	15.4			1269	15.2
		25%	411	27.7	450	39.5	731	24.3			803	24
		30%	256	44.4	281	63.3	457	39			502	38.4
	180° F	20%	830*	13.7*	909*	19.5*	1477	12			1623	11.9
		25%	525*	21.6*	576*	30.9*	936	19			1028	18.7
		30%	328*	34.7*	360*	49.5*	584	30.4			642	30
	200° F	20%	971*	11.7*	1065*	16.7*	1730*	10.2*			1901	10.1*
		25%	615*	18.5*	674*	26.4*	1096*	16.2*			1204	16.0*
		30%	384*	29.6*	421*	42.2*	684*	26.0*			752	25.6*
30 H.P. 42" Fan 10.25 million BTU	160° F	20%	740	15.4	806	22			819	23.5	1452	13.2
		25%	469	24.3	511	34.8			519	37.1	920	20.9
		30%	293	38.9	319	55.8			324	59.4	574	33.5
	180° F	20%	947	12	1032	17.2			1048	18.3	1858	10.4
		25%	600	19	653	27.2			664	29	1177	16.3
		30%	375	30.4	408	43.6			415	46.4	735	26.1
	200° F	20%	1109	10.2	1208	14.7			1227	15.6	2176	8.8
		25%	702	16.2	765	23.2			777	24.7	1378	14
		30%	439	25.9	478	37.2			486	39.6	861	22.4
40 H.P. 42" Fan 10.25 million BTU	160° F	20%			920	19.3			950	20.2		
		25%			583	30.5			602	32		
		30%			364	48.9			376	51.2		
	180° F	20%			1178	15.1			1216	15.8		
		25%			746	23.8			770	25		
		30%			466	38.2			481	40		
	200° F	20%			1379	12.9			1424	13.5		
		25%			873	20.3			902	21.3		
		30%			545	32.6			563	34.2		

NOTE: * Insufficient burner BTUs for 45°F ambient temperature.
 Batch Capacities exclude loading time. Final moisture 15% after complete cooling.
 Estimated at 45°F. ambient temperature, 65% relative humidity. 1/3 CFM/Bu. cooling rate.
 Capacities listed are wet bushels/tonnes, for mature unfrozen #2 yellow shelled dent corn at listed moisture content and are estimates based on drying principles, field results and computer simulation. Variance may occur due to grain's physiological factors (kernel size, chemical composition, variety, maturity), excessive fines, adverse weather conditions, etc.

Storage Capacity

Table 2-2 Storage Capacity

Bin Diameter	Grain in Process (BU)	Dump Size (BU)	Rings	Eave Height	Peak Height	Maximum Storage (BU)
24 ft.	560	187	5	18'-5"	25'-0"	4,373
			6	22'-1"	28'-8"	5,758
			7	25'-9"	32'-4"	7,143
			8	29'-5"	36'-0"	8,528
			9	33'-1"	39'-8"	9,913
			10	36'-9"	43'-4"	11,298
30 ft.	845	282	5	18'-5"	26'-9"	6,804
			6	22'-1"	30'-5"	8,968
			7	25'-9"	34'-1"	11,132
			8	29'-5"	37'-9"	13,296
			9	33'-1"	41'-5"	15,460
			10	36'-9"	45'-1"	17,624
			11	40'-5"	48'-9"	19,788
36 ft.	1215	303	6	22'-1"	32'-6"	12,914
			7	25'-9"	36'-2"	16,029
			8	29'-5"	39'-10"	19,144
			9	33'-1"	43'-6"	22,259
			10	36'-9"	47'-2"	25,374
			11	40'-5"	50'-10"	28,489
			12	44'-1"	54'-6"	32,549

NOTE: Maximum storage estimated with 12 in. aeration floor, level to bottom of fan entrance, with upper batch filled.

NOTES

3 Gas and Electrical Specifications

Topics Covered in this Chapter

- The Fuel Supply
- Electrical Load Information

The Fuel Supply

You can choose either Liquid Propane (LP) or Natural Gas (NG) to fuel the heater(s) for your TopDry.

Liquid Propane

If using LP gas, make sure to slowly open the main fuel supply valve at the supply tank.

Table 3-1 *Liquid Propane (LP) Fuel Recommendations*

Dryer Fan Size	Dryer Horsepower	Maximum Heat Capacity BTU per Hour	Maximum Fuel Flow Gallons per Hour	Minimum Line Size	Orifice Size	Minimum Operating Pressure	Maximum Operating Pressure
36 in.	15	4.5 Million	49	1/2 in.	21/64 in.	2 lbs.	14 lbs.
40 in.	15	5.95 Million	63	1/2 in.	11/32 in.	2 lbs.	18.5 lbs.
42 in.	30	8.75 Million	95	1/2 in.	7/16 in.	2 lbs.	16 lbs.
42 in.	40	10.25 Million	112	3/4 in.	29/64 in.	2 lbs.	19.5 lbs.

Natural Gas

If using natural gas, turn ON the valve along the supply line. Then open the ball valve on the fan heater unit(s).

Table 3-2 *Natural Gas (NG) Fuel Recommendations*

Dryer Fan Size	Dryer Horsepower	Maximum Heat Capacity BTU per Hour	Maximum Fuel Flow Cubic Ft. per Hour	Minimum Line Size	Orifice Size	Minimum Operating Pressure	Maximum Operating Pressure
36 in.	15	4.5 Million	4500	2 in.	27/64 in.	1 lb.	12.5 lbs.
40 in.	15	5.75 Million	5750	2 in.	33/64 in.	1 lb.	9 lbs.
42 in.	30	8.75 Million	8750	2 in.	19/32 in.	1 lb.	12 lbs.
42 in.	40	10.25 Million	10,250	2 in.	23/32 in.	1 lb.	8 lbs.

Electrical Load Information

The chart below is a reference for the electrician wiring the grain dryer. It is recommended that you contact your local power company and have a representatives survey the installation to make sure that the wiring is compatible with their system and that adequate power is supplied to the unit.



The grain dryer must be the only equipment connected to the recommended service amps. Standard electrical safety procedures must be used. (Refer to the National Electrical Code Standard Handbook by the National Fire Protection Association.) A qualified electrician must make all electrical wiring installations.

Dryer Fan Size	Voltage	Horsepower	Full Load Amps	Fuse (Slow Blow)	Breaker
36 in.	220V 1 PH	15	78	150	150
	208V 3 PH	15	44	125	125
	220V 3 PH	15	39	100	100
	380V 50 Hz	15	27	80	80
	460V 3 PH	15	20	50	50
	575V 3 PH	15	16	40	40
40 in.	220V 1 PH	15	78	150	150
	208V 3 PH	15	44	125	125
	220V 3 PH	15	39	100	100
	380V 50 Hz	15	27	80	80
	460V 3 PH	15	20	50	50
	575V 3 PH	15	16	40	40
42 in.	208V 3 PH	30	80	150	150
	220V 3 PH	30	74	150	150
	380V 50 Hz	30	39	100	100
	460V 3 PH	30	37	100	100
	575V 3 PH	30	30	80	80
42 in.	208V 3 PH	40	108	200	200
	220V 3 PH	40	102	200	200
	380V 50 Hz	40	47	100	100
	460V 3 PH	40	51	100	100
	575V 3 PH	40	40	100	100

4 Control Panels

Topics Covered in this Chapter

- The TopDry Batch Terminal Control Panel
- Powering on the Touchscreen
- Overview of the User Interface
- Configuring the Operational Settings for the TopDry Batch Terminal
- The Timer Menu
- Setting the Timers
- The Temperature Menu
- Setting the Temperature Limits
- Setting the Temperature Setpoints for the Plenum and Grain from the Main Screen
- The Information Menu
- Factory Default Settings

The TopDry Batch Terminal Control Panel

Along with the touchscreen user interface, the control panel contains all buttons and switches that allow you to set up and operate your dryer.

Figure 4-1 The TopDry Batch Terminal



NOTE: Images of the dryer, control panel, and user interface menus that are included in this guide are for illustrative purposes only and may not entirely resemble the actual product.

Table 4-1 The components of the TopDry Batch Terminal

Item	Name	Description
1	Touchscreen	Allows you to access all of the user interface menus and set all parameters. (See Overview of the User Interface , page 32 for details.)
2	Control power switch	Controls the power to the TopDry system by way of the following modes: <ul style="list-style-type: none"> • OFF: The TopDry Batch Terminal will not operate. • ON: The switch illuminates when the TopDry Batch Terminal is successfully powered up. Note the following: <ul style="list-style-type: none"> • If the switch is placed in the ON position and the light does not illuminate, make sure that the Emergency Stop switches located on the TopDry Batch Terminal and each fan control box are pulled out.

Table 4-1 The components of the TopDry Batch Terminal (cont'd.)

Item	Name	Description
3	Fan switch	<p>Controls the main drying fans by way of the following modes:</p> <ul style="list-style-type: none"> • OFF: The main drying fan(s) do not operate. • ON: The main drying fan(s) will operate continuously during the dry cycle. <p>Note the following:</p> <ul style="list-style-type: none"> • The Fan switch will illuminate and flash until the air switches are closed.
4	Heater switch	<p>Controls the burner(s) operation by way of the following modes:</p> <ul style="list-style-type: none"> • OFF: The heater(s) do not ignite. • ON: The burner(s) will ignite after the main drying fan(s) are operating and the purge time has elapsed. <p>Note the following:</p> <ul style="list-style-type: none"> • The Heater switch will blink during the ignition cycle and will remain solid once the burner(s) are ignited.
5	Dryer Power button	<p>This button energizes the control switches and operates the dryer based on the switch settings.</p> <p>Note the following:</p> <ul style="list-style-type: none"> • The Dryer Power button illuminates when the dryer is operating.
6	Stop button	<p>Stops all dryer functions and clears error messages; not to be confused with the Stop button on the touchscreen, which is included in the user interface's main menu.</p> <p>Note the following:</p> <ul style="list-style-type: none"> • If an automatic dryer shut down occurs, first determine and correct the cause of the shut down. Then, press the Stop button to reset the dryer before starting.
7	Emergency stop (E-stop)	<p>A safety device used to turn OFF the dryer's control power and immediately stop all of its functions (the main power, which is controlled by the main electrical disconnect, does not turn OFF when you press the Emergency Stop plunger.</p> <p>DANGER:</p> <ul style="list-style-type: none"> • Never disable an Emergency Stop. Make sure all safety devices are installed and work properly.

Powering on the Touchscreen

What You Should Know

The touchscreen on the TopDry Batch Terminal allows you to configure all timing functions, temperature controls, safety circuit checks and dryer setup parameters. It is designed to simplify operation by providing a touch control of the dryer and a self-diagnostic of the TopDry.

Figure 4-2 TopDry Batch Terminal touchscreen (main menu)

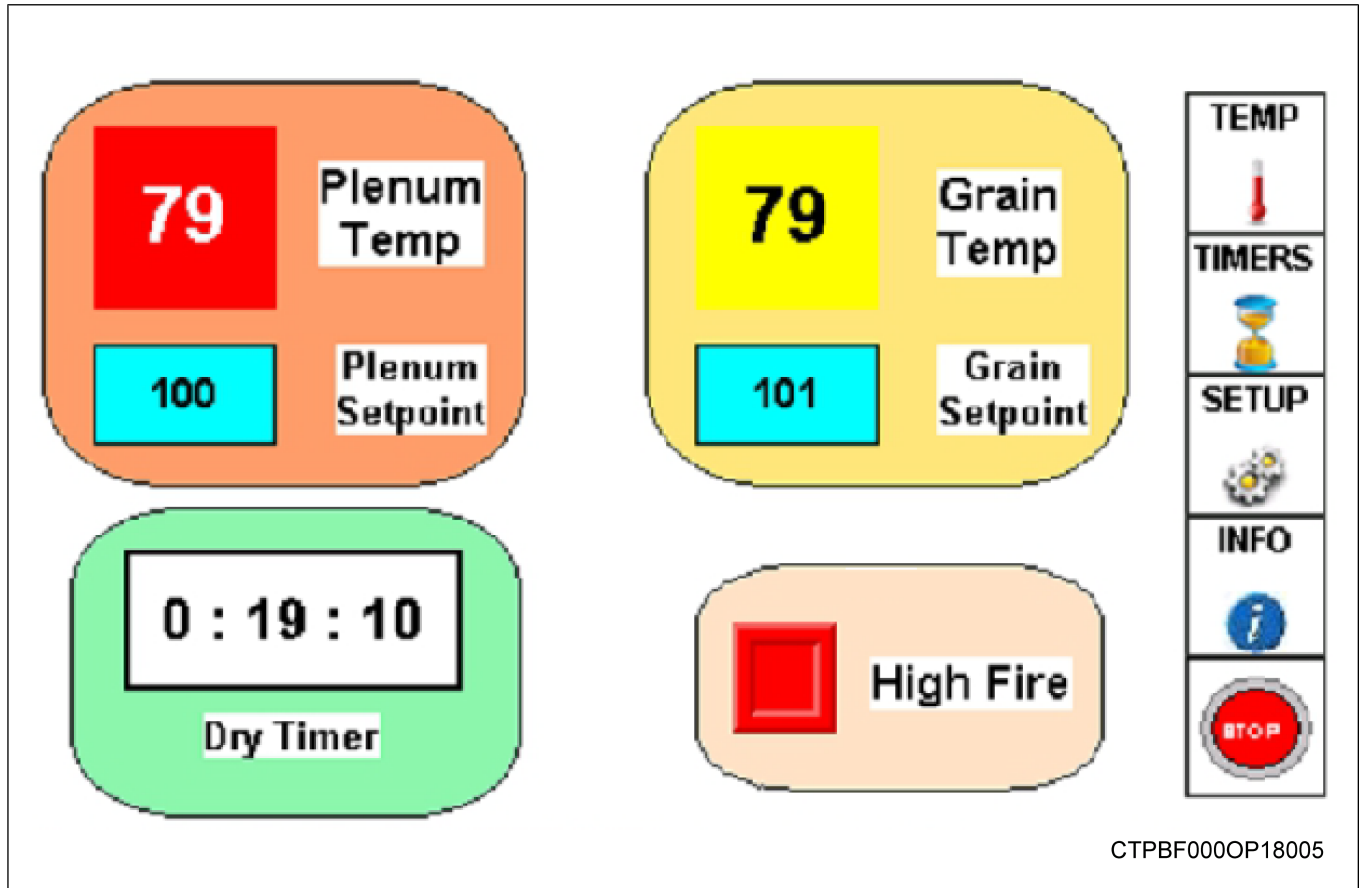

1. Make sure the main power supply is ON to the TopDry system.
2. Turn the **Control Power** switch on the TopDry Batch Terminal to the **ON** position.

The touchscreen will start to boot and the main screen will appear.

Overview of the User Interface

The user interface allows you to access all operation and information windows via a touch-sensitive screen. The interface includes an intuitive menu structure that allows you to easily locate parameter settings and system information.

The Main Menu

The main menu serves as a starting point for all your dryer related operations. In addition to providing access to all parameter settings, the main menu displays real-time temperature and timer settings.

Figure 4-3 The main menu with all displays shown

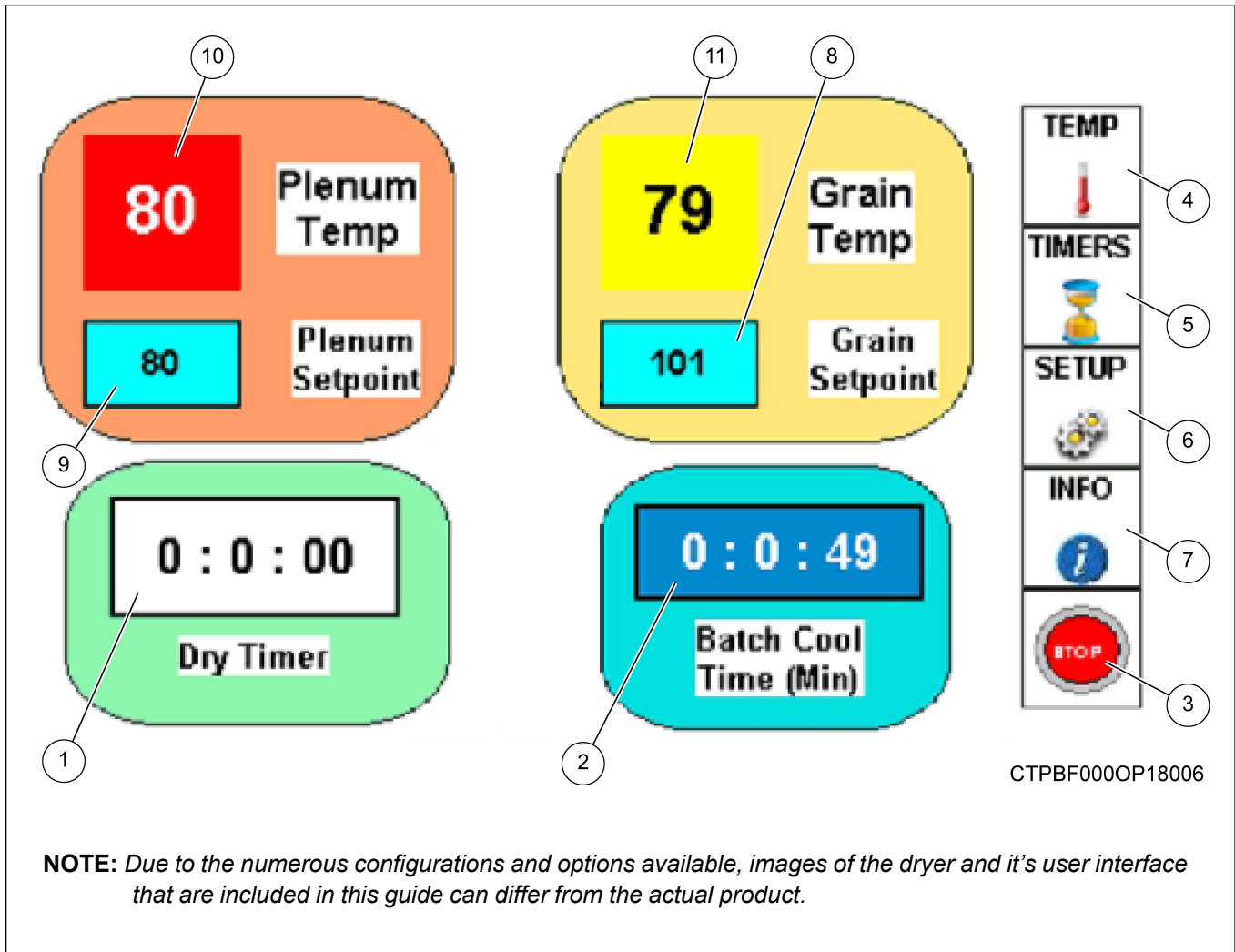

NOTE: Due to the numerous configurations and options available, images of the dryer and its user interface that are included in this guide can differ from the actual product.

Table 4-2 Description of the main menu's buttons and displays

Item	Name	Description
1	Dry timer button	Shortcut that allows you to quickly modify the time the burner operates; displays current time remaining
2	Batch cool time (min) button	Used in AutoBatch Mode Only, shortcut allows you to quickly modify the time the grain is cooled before it is dumped; displays current time remaining
3	Stop button	Stops all dryer functions
4	Temp menu button	Allows you to access the temperature menu
5	Timers menu button	Allows you to access the timer menu
6	Setup menu button	Allows you to access the setup menu
7	Info menu button	Allows you to access the information menu
8	Grain setpoint button	Shortcut that allows you to quickly modify the setpoint temperature of the grain; displays the current grain temperature setpoint
9	Plenum setpoint button	Shortcut that allows you to quickly modify the setpoint temperature of the plenum; displays the current plenum temperature setpoint
10	Plenum temp	Displays the current temperature of the plenum
11	Grain temp	Displays the current temperature of the grain in the drying chamber

Configuring the Operational Settings for the TopDry Batch Terminal

By clicking the **Setup** icon on the main menu, you can configure settings for your system. These settings can vary depending on the equipment installed on your TopDry.

What You Should Know

Figure 4-4 The setup menu

Item	Name	Item	Name
1	Temperature Mode	5	Clock Update
2	Time or Temperature Mode	6	Software Versions
3	Fan/Heater 1, 2 Enabled	7	Exit
4	Dry and Cool Enabled		

To configure the TopDry Batch Terminal to your system:

1. Click the **Setup** icon from the main menu.
2. Set the following parameters:

NOTE: *The current settings are highlighted in green.*

Discharge Mode — Selects how the system determines when the cycle is complete. The available discharge modes are the following:

- **Temperature Mode:** The fan and heater will run until the grain temperature reaches the Grain Temperature setpoint. After the Grain Temperature setpoint is met, the heater will turn OFF.
- If the **Dry and Cool** option is turned ON, the drying fan will continue to run after the heater shuts down for the time specified in the Batch Cool Time parameter. If Batch Cool Time is set to zero, the fan will turn OFF with the burner.
- **Time or Temperature Mode:** The fan and heater will run until either (1) the Dry Timer expires OR (2) the grain temperature reaches the Grain Temperature setpoint. After these conditions are true, the heater will turn OFF.

Fan/Heater Enable — Controls which drying fan and heater(s) are selected for operation.

Clock Update — Sets the year, month, day, hour, minute, and seconds on the TopDry's internal clock.

Software Versions — Current HMI (Touchscreen) and PLC program names are displayed.

3. Click the **Exit** to return to the main menu.

The Timer Menu

You can access and set all parameters for the timers from the same menu. The figure that follows illustrates and describes the parameter fields.

Figure 4-5 *Timer menu*

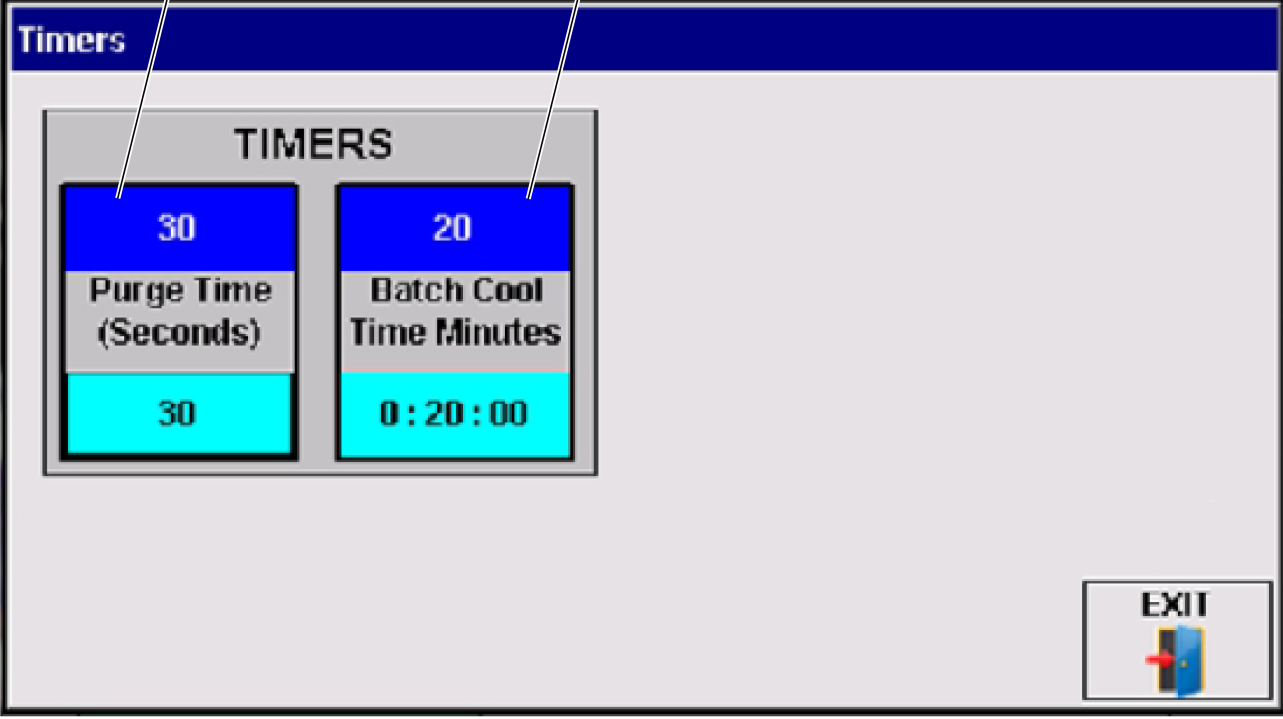

The screenshot shows a control panel interface for timers. At the top, a dark blue header bar contains the word "Timers" in white. Below this, a grey rectangular area is titled "TIMERS". Inside this area, there are two vertical panels. The left panel has a blue top section with the number "30", a grey middle section with the text "Purge Time (Seconds)", and a cyan bottom section with the number "30". A callout circle with the number "1" points to the top section. The right panel has a blue top section with the number "20", a grey middle section with the text "Batch Cool Time Minutes", and a cyan bottom section with the time "0 : 20 : 00". A callout circle with the number "2" points to the top section. In the bottom right corner of the grey area, there is a button labeled "EXIT" with a red arrow pointing to a blue door icon. Below the screenshot, the text "CTPBF000OP18008" is displayed.

Item	Name	Item	Name
1	Purge time (seconds)	2	Batch cool time minutes

Setting the Timers

By clicking the **Timers** icon on the main menu, you can set the time for Batch Cool and Purge timers.

What You Should Know

The timers perform the following functions:

- The **Batch Cool Timer** can be used to cool grain after the dry cycle.
- The **Purge Timer** is the amount of time the fan(s) must operate before the burner will light on initial start-up. For domestic dryers, this timer will always be set to 30 seconds.

To change the setting on any timer:

1. Click the **Timers** icon shown on the main menu.

The Timers window will be displayed, providing access to all of the timer settings.

2. Click the dark blue (upper portion) of the button to launch the keypad.

NOTE: *The light blue portion on any of the buttons displays the time remaining on that timer. If the dryer is momentarily stopped for any reason, the timers will stop, but will continue counting down when the dryer is restarted.*

3. Enter the desired time using the keypad and click the “Enter” key (lower right hand button) which will enter the new value into the TopDry Batch Terminal memory.
4. Click **Exit** to return to the main menu.

The Temperature Menu

The temperature menu allows you to adjust the temperature limits for the daily operation of your dryer.

Figure 4-6 The Temperature menu

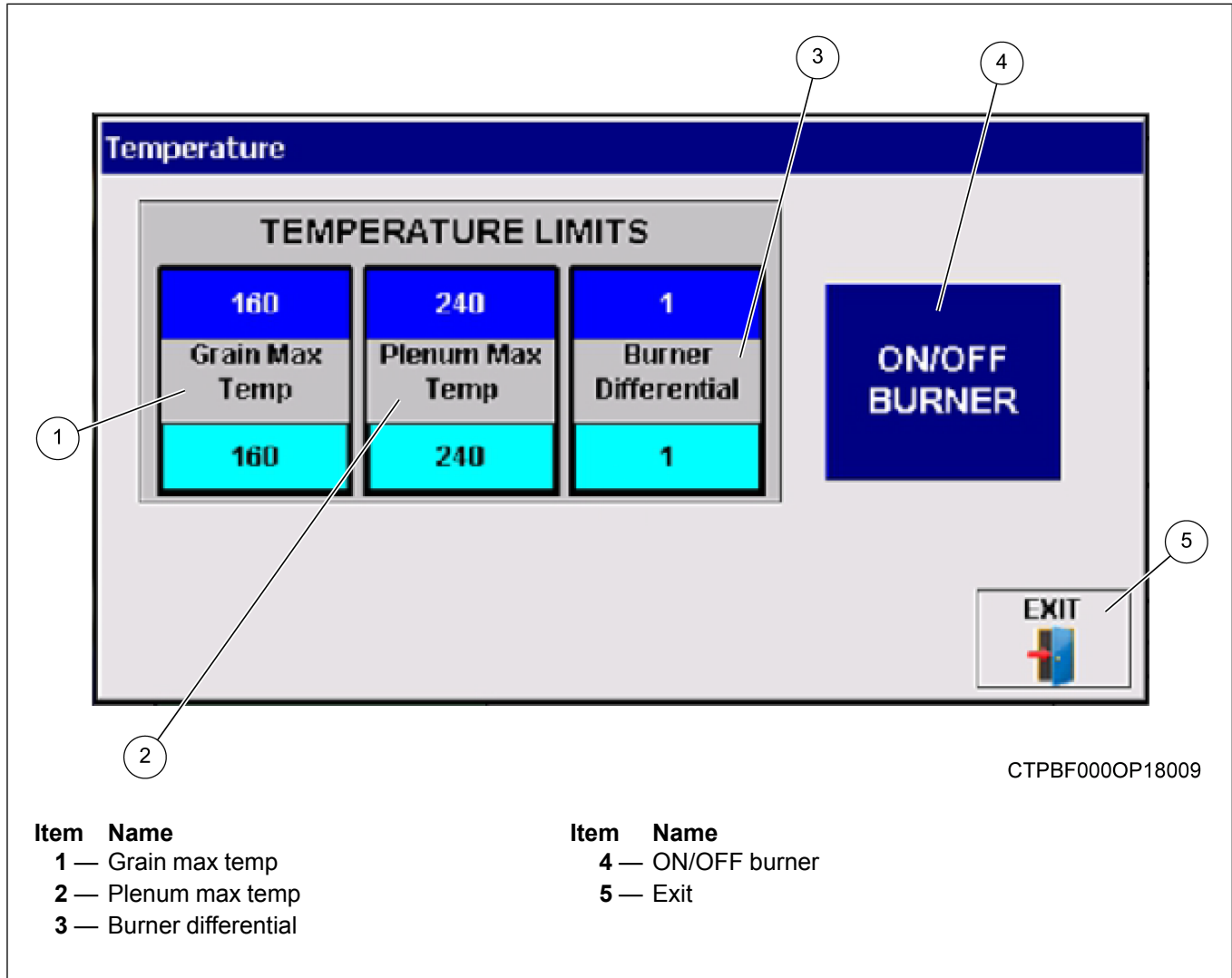

Setting the Temperature Limits

By clicking the **TEMP** icon from the main menu, you can enable and set the limits of the temperature sensors.

1. Set the temperature high limits by clicking on the dark blue area of the **Grain Max Temp** button and the **Plenum Max Temp** button.

NOTE: The current settings are shown in the light blue area of the button.

2. **Burner Differential:** The temperature differential that the burner(s) will cycle between on a high and low firing rate during Hi-Lo burner operation.
3. Click the **Exit** button to return to the main menu.

Setting the Temperature Setpoints for the Plenum and Grain from the Main Screen

By clicking anywhere within the plenum or grain temp rectangles, you can configure the temperature setpoints for the plenum and grain. These settings can also be set from the temperature screen.

To adjust the Plenum or Grain setpoint temperature:

1. Click the **Plenum Temp** box or the **Grain Temp** box on the main screen.

NOTE: The current settings are shown in light blue of the button.

Figure 4-7 Temperature box

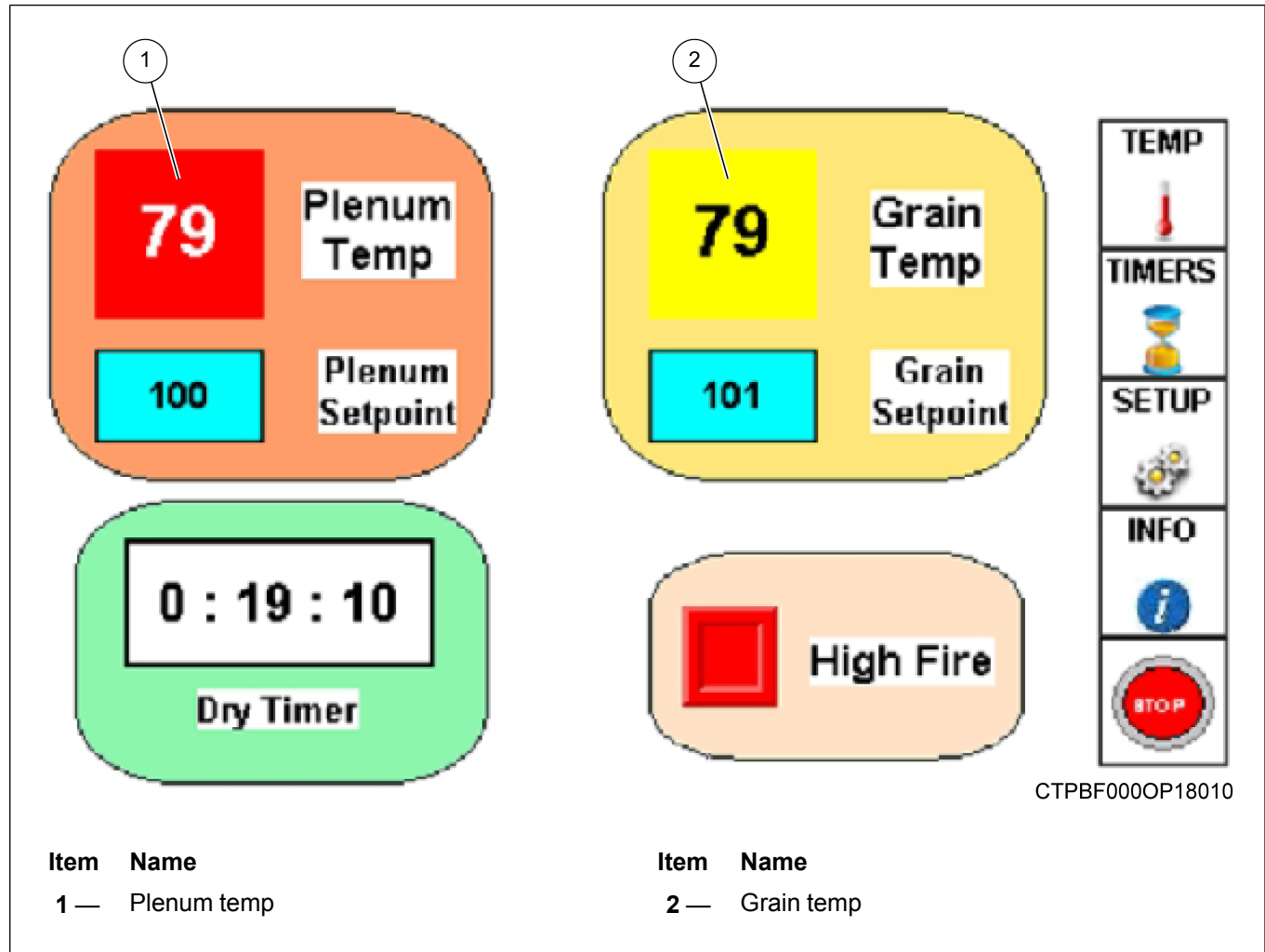

Chapter 4: Control Panels

2. Enter the desired temperature into the keypad and click enter or use up/down arrows to set desired temperature and click enter.

Figure 4-8 Temperature adjustment

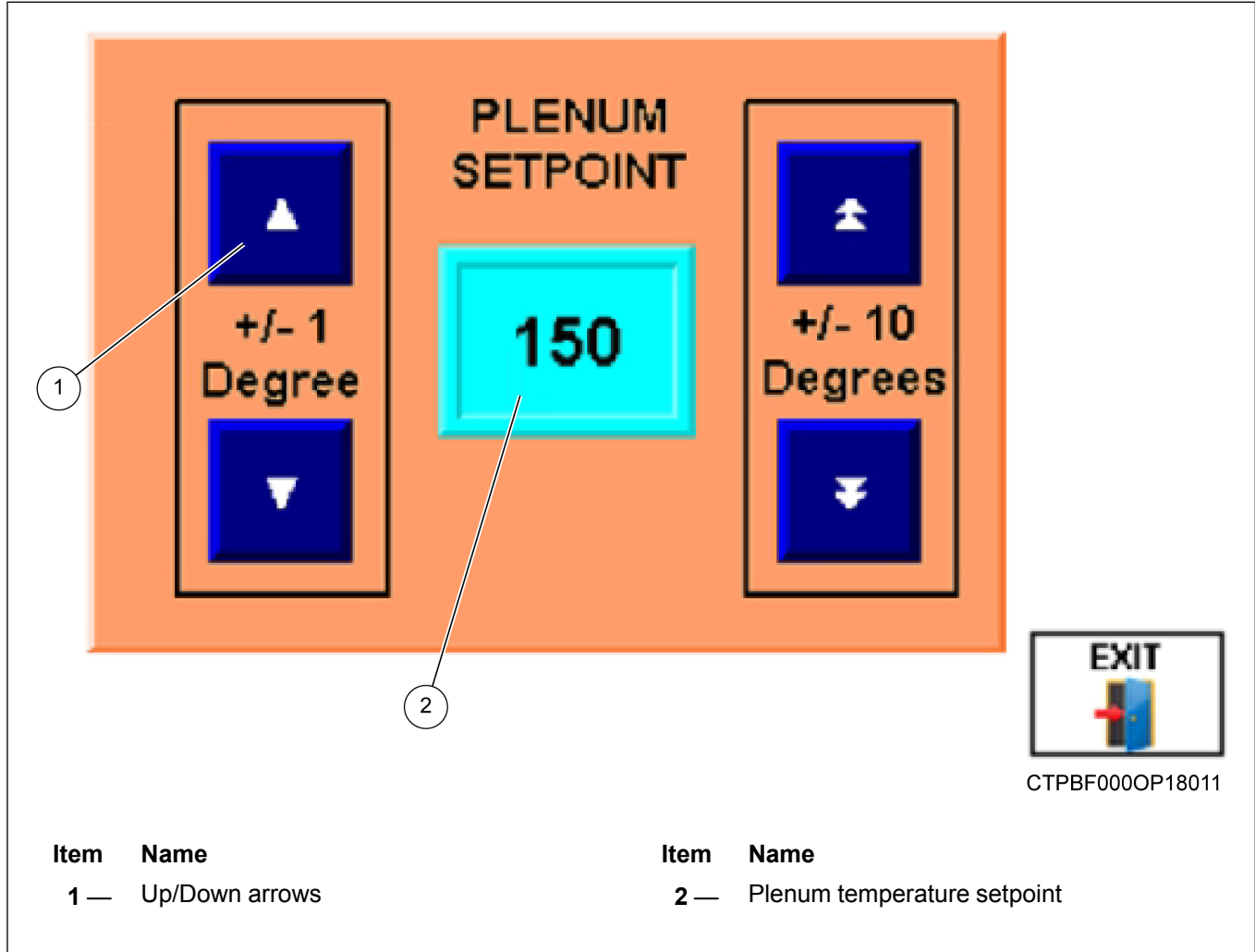

The Information Menu

The information menu allows you to view alarms, setup a Watchdog message, view operation history and access a graphic diagnostic display of the control boards.

Figure 4-9 The information menu

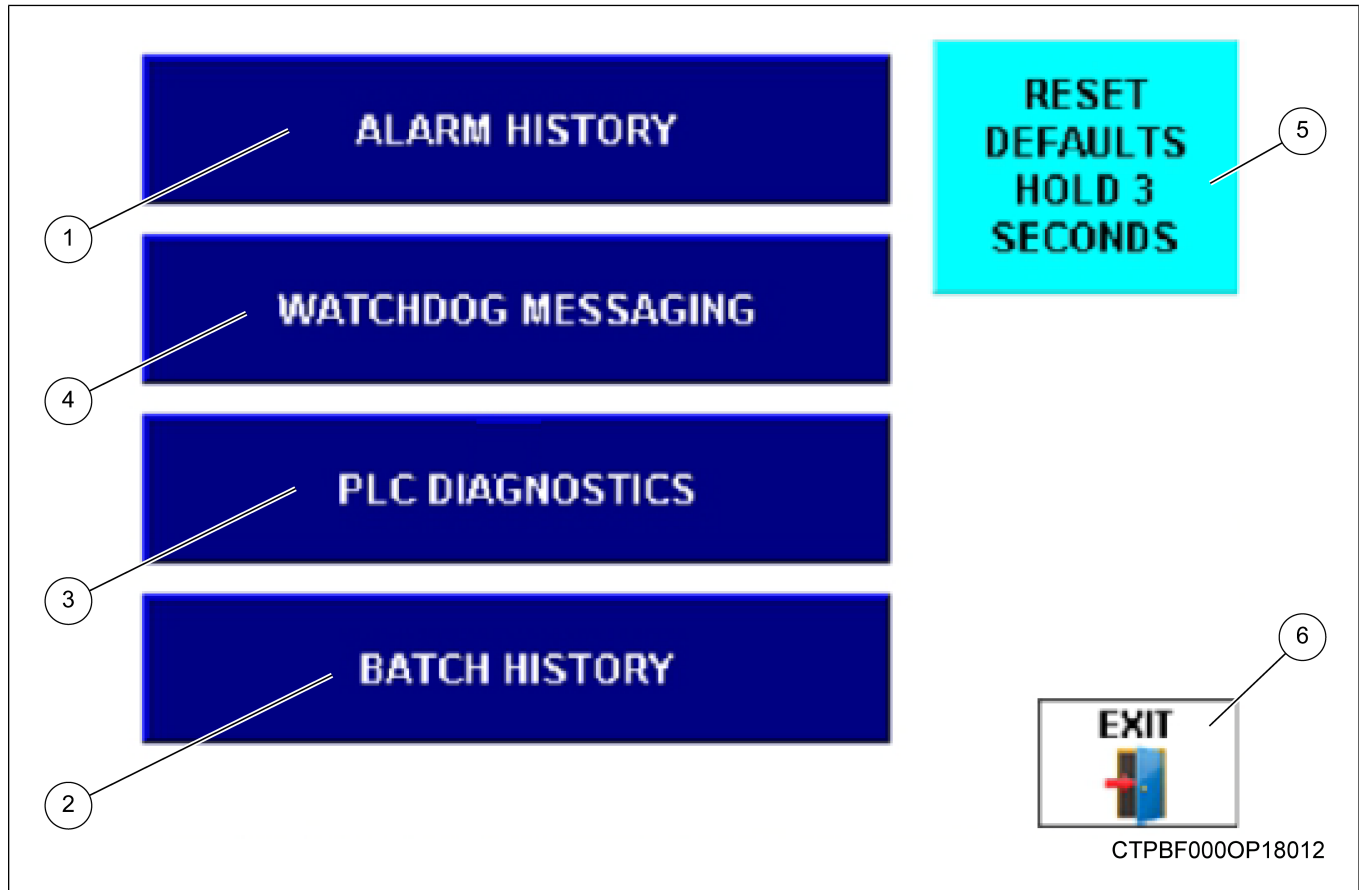

Table 4-3 The information menu

Item	Name	Description
1	Alarm History	Allows you to view the alarm history.
2	Batch History	Allows you to view information about the last ten dump cycles. The cycle duration, plenum temperature, grain temperature, date and the time are displayed.
3	PLC diagnostics	Aids in troubleshooting a PLC problem; displays the status of the PLC inputs and outputs.
4	Watchdog messaging	Allows you to set up the messaging feature available through the TopDry Batch Terminal.
5	Reset defaults	Resets all parameter settings to the factory default settings. (Refer to Factory Default Settings, page 42.)
6	Exit	Exit back to the main menu.

Factory Default Settings

You can reference the default factory settings to compare them with any changes you may have made.

Table 4-4 *TopDry Batch Terminal default settings*

Parameter	Factory Value	Units
Drying Mode	Time or Temp Mode	
Burner Hi-Lo or On/Off Mode	Hi-Lo	
Dry and Cool Mode	ON	
Heater 1	ON	
Heater 2	OFF	
Batch Cool Time	20	minutes
Purge Time	30	seconds
Grain Max Temp	160	°F
Plenum Max Temp	240	°F
Grain Temp Setpoint	101	°F
Plenum Temp Setpoint	150	°F
Dry Timer	20	minutes
Burner Differential	1	°F

5 Getting Started

Topics Covered in this Chapter

- Pre-Season Inspections
- Testing the Dump Chutes
- Testing the Air Switch
- Testing the Burner

Pre-Season Inspections

Before the dryer is started or filled, fully inspect the TopDry system to ensure all components are in good working order.



Make sure all power sources are locked out and tagged out. If entering the bin, follow confined space entry procedures.

Drying Chamber

- Inspect dump hoppers for obstructions.
- Make sure that the gaps between the dump chutes and the floor sheets are a minimum of 1-1/2 in.
- Make sure leveling bands are installed correctly and are not damaged.

Dump Chutes

- Make sure the dump chutes are level and parallel to the storage floor.
- Make sure the center plate is no more than 12 in. from the pulley when the chutes are closed (level). If the center plate is further than 12 in. from the pulley when the chutes are closed, the chains must be lengthened.

Fuel Supply

- Make sure an adequate gas supply is available.
- Inspect all gas lines and connections for leaks.
- Fix any gas leaks immediately.

Fans

- Make sure fans rotate freely in the correct direction.

Electrical Components

- Make sure there are no loose or bare wires.

Testing the Dump Chutes

You must mark the Open and Closed positions and test that the winch is working properly.

1. Turn the winch handle until the chutes are in the closed position and inspect that the dump chutes are level.
2. Install a cable clamp onto the cable directly above the winch stop bracket. The cable clamp will prevent the cable from travelling any farther than the stop bracket, indicating the chutes are closed.
3. Turn the winch handle until the chutes are fully opened. Permanently mark the bin where the cable clamp is aligned and label it “Open”.

Figure 5-1 Winch assembly

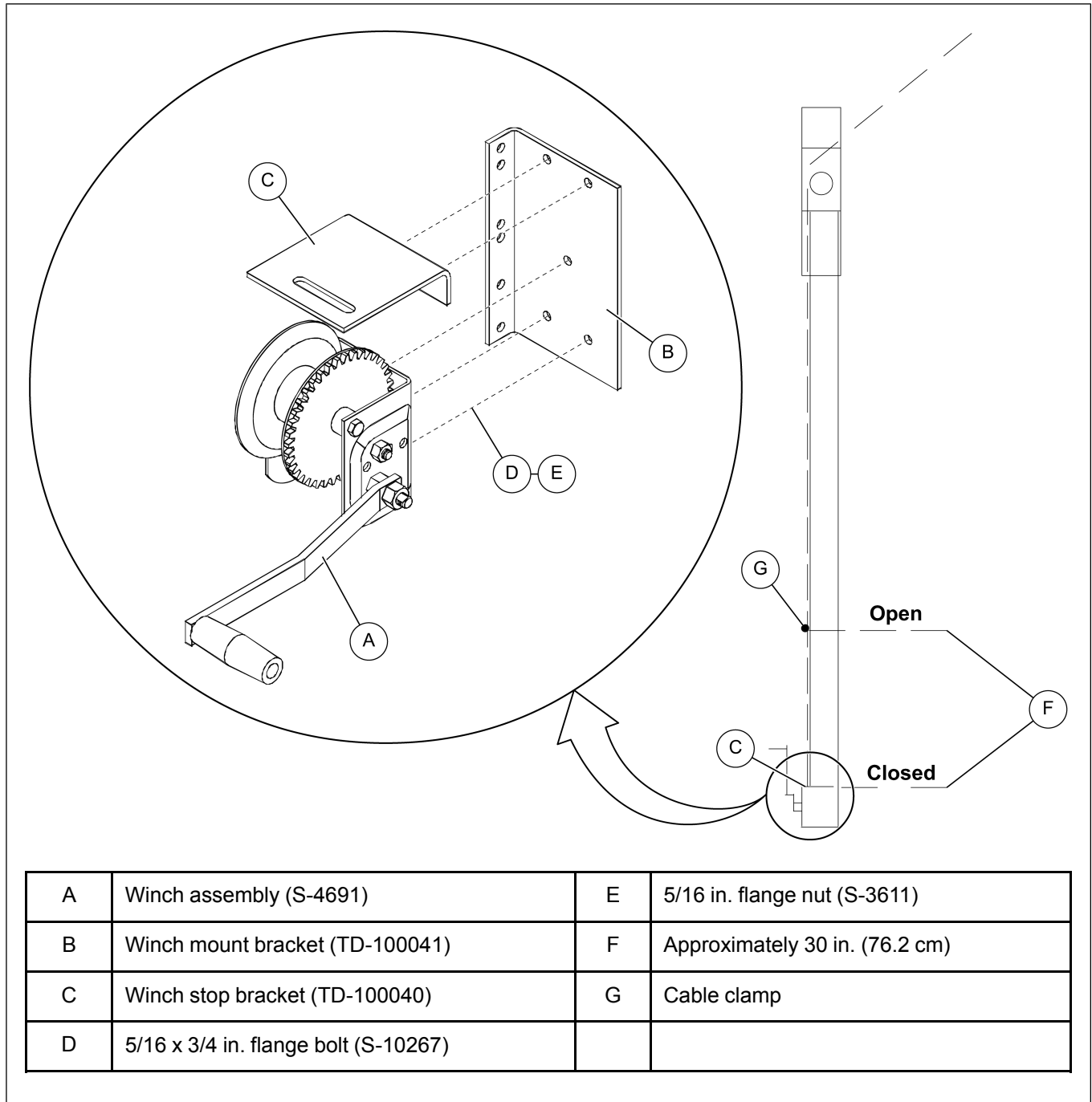

Testing the Air Switch

Airflow must be detected by the air switch before the heaters will begin to operate.

Before You Begin

- Make sure you have completed the pre-season inspections.
- E-Stops are pulled out.
- Power has been supplied to the system.
- Turn all switches on the TopDry Batch Terminal to **OFF**.
- Turn the **Control Power** switch to **ON**.
- Push the **Dryer Power Start** button.

To test the airflow switch:

1. Turn the **Fan** switch to **ON**.

Single Fan Unit: The fan switch light will blink until the fan has started and the airflow switch is closed.

Two Fan Unit: In a two fan unit, the fan switch light will blink until both fans have started and the airflow switch is closed.

2. Turn the **Aeration Fan** switch to **ON**.
3. Turn the **Fan** switch to **OFF**.

To adjust the airflow switch:

4. Locate the airflow switch in the fan electrical box.
5. Turn the airflow switch clockwise to decrease sensitivity and counterclockwise to increase sensitivity.

Testing the Burner

The burners are connected to the heater ducts at the base of the bin. You must test the fans and burners prior to operating the TopDry system.

Before You Begin

- Make sure you have completed the pre-season inspections.
- E-Stops are pulled out.
- Power has been supplied to the system.
- Turn ON the fuel supply.
- Turn all switches on the TopDry Batch Terminal to **OFF**.
- Turn the **Control Power** switch to **ON**.
- Push the **Dryer Power Start** button.

To test the burner:

1. Turn the **Fan** switch to **ON**.
2. Turn the **Heater** switch to **ON**.

The burner will light after the purge delay and the light in the heater switch will blink during the purge and ignition period. Once a flame is sensed, the light will stop flashing and remain ON.

3. Set the high-fire and low-fire gas pressures (See Adjusting the gas pressure):
 - LP Settings: high-fire set to 6–15 lbs., low-fire set to 2–6 lbs.
 - NG Settings: high-fire set to 6–10 lbs., set to 1–3 lbs.

NOTE: *Do not set the pressure to low as to cause the burner to make popping noises when in low fire. This can damage the burner.*

6 Operation

Topics Covered in this Chapter

- Shutting OFF the Dryer in an Emergency
- Initial Dryer Start-Up
- Shutting OFF the Dryer

Shutting OFF the Dryer in an Emergency

What You Should Know



Never disable an Emergency Stop. Make sure all safety devices are installed and operate properly.

1. Push the **Emergency Stop** on the TopDry Batch Terminal or any of the other **Emergency Stop** locations.

This will turn OFF the dryer's control power and immediately stop all of its functions.

NOTE: Pressing the **Emergency Stop** button stops dryer functions but does not turn OFF the power that is present at the various electrical cabinets. Turn OFF the main electrical disconnect switch to shut OFF power to the dryer and all electrical cabinets. Failure to do so might lead to serious injury or death.

2. Turn OFF the main electrical disconnect.

Figure 6-1 Emergency Stops (E-Stops)



Initial Dryer Start-Up

Before You Begin

- Make sure to complete all pre-season checks and tests. Refer to [Chapter 5 Getting Started, page 43](#).
- Make sure there is wet grain ready to be loaded.



Make sure all personnel are clear from the TopDry and loading systems before starting or operating your equipment. Lock out all power sources before performing any testing or maintenance. Equipment can automatically start without warning.

1. Turn **ON** the main power supply.
2. Turn the Control Power to **ON** and wait for the touch screen to appear.
3. Use the Touch Screen to set your drying parameters. Refer to [The TopDry Batch Terminal Control Panel, page 30](#) for setting options.
4. Turn the Fan switch to **ON**.
5. Push the Dryer Power button.

Shutting OFF the Dryer

A proper daily shut OFF procedure prolongs the life of your equipment.

1. Close the fuel supply valve at the tank or along the fuel supply line.
2. If the burner is operating, let the dryer run out of fuel.
This will result in a *Loss of Flame Error*.
3. Press the **Dryer Power Stop** button to clear the error.
4. Turn the **Control Power** switch to the **OFF** position.
5. Turn **OFF** the main power disconnect at the entrance panel.

7 Troubleshooting

Topics Covered in this Chapter

- TopDry Batch Terminal Error Messages

TopDry Batch Terminal Error Messages

Error Message	Cause/Remedy
Heater 1 Fan Contactor Aux Contacts Failed to Close	The auxiliary contacts on the fan #1 motor starter failed to close when the starter was energized. Check that starter #1 is pulling in when energized.
Heater 1 Fan Contactor Aux Contacts Stuck Closed	Check to see if the starter contacts are stuck closed or if the starter is staying engaged after.
Heater 2 Fan Contactor Aux Contacts Failed to Close	The auxiliary contacts on the fan #2 motor starter failed to close when the starter was energized. Check that starter #1 is pulling in when energized.
Heater 2 Fan Contactor Aux Contacts Stuck Closed	Check to see if the starter contacts are stuck closed or if the starter is staying engaged after.
Analog Grain Temp Hi-Limit Tripped	The grain temperature has exceeded the Plenum Grain Temp setpoint entered on the Temperature Menu. Check for plugged dump chutes or check for over-dried grain.
Analog Plenum Temp Hi-Limit Tripped	The plenum temperature has exceeded the Plenum Max Temp setpoint entered on the Temperature Menu. Lower the low fire gas pressure setting or lower the plenum temperature setpoint.
Plenum Temp Sensor Open	The controller sees an open electrical connection to the plenum temperature sensor. Check wiring or replace sensor.
Plenum Temp Sensor Shorted	The controller sees a shorted electrical connection to the plenum temperature sensor. Check wiring or replace sensor.
Grain Temp Sensor Open	The TopDry Batch Terminal sees an open electrical connection to the grain temp sensor. Check wiring or replace sensor. Temporarily disable grain temp sensor in the Temperature Menu to continue drying.
Grain Temp Sensor Shorted	The TopDry Batch Terminal sees a shorted electrical connection to the grain temp sensor. Check wiring or replace sensor. Temporarily disable grain temp sensor in the Temperature Menu to continue drying.
Heater 1 Housing Temp Hi-Limit	The temperature high limit located on the housing of fan and heater #1 has opened, indicating that the housing has overheated. The high limit sensor must be manually reset.
Heater 2 Housing Temp Hi-Limit	The temperature high limit located on the housing of fan and heater #2 opened, indicating that the housing has overheated. The high limit sensor must be manually reset.
Heater 1 Gas Vapor Temp Hi-Limit	The LP gas vapor temperature sensor located in the gas pipe downstream from the vaporizer coil on fan and heater #1 has opened indicating that the vaporizer coil is running too hot. The vaporizer is adjusted by loosening the bolt and moving the vaporizer away from the flame. The sensor automatically resets itself.

Chapter 7: Troubleshooting

Error Message	Cause/Remedy
Heater 2 Gas Vapor Temp Hi-Limit	The LP gas vapor temperature sensor located in the gas pipe downstream from the vaporizer coil on fan and heater #2 has opened indicating that the vaporizer coil is running too hot. The vaporizer is adjusted by loosening the bolt and moving the vaporizer away from the flame. The sensor automatically resets itself.
Plenum Temp Hi-Limit - Digital	The plenum temperature has exceeded the Plenum Max Temp value on the Temperature menu.
Heater 1 Gas Pressure Out of Range	The optional gas pressure switch on heater #1 fuel train has opened. Reduce gas pressure.
Heater 2 Gas Pressure Out of Range	The optional gas pressure switch on heater #2 fuel train has opened. Reduce gas pressure
Heater 1 Heater Ignition Failure	Heater #1 failed to light during the ignition period. Either the heater failed to light or the flame sensor needs adjustment. The flame sensor can be bent so that it will be in the flame. If the heater is not lighting, make sure that the dryer is getting fuel, all solenoids are opening, and the ignitor is sparking.
Heater 2 Heater Ignition Failure	Heater #2 failed to light during the ignition period. Either the heater failed to light or the flame sensor needs adjustment. The flame sensor can be bent so that it will be in the flame. If the heater is not lighting, make sure that the dryer is getting fuel, all solenoids are opening, and the ignitor is sparking.
Heater 1 Heater Flame Lost	Heater #1 lost flame after it has initially lighted. Adjust the flame sensor so that it is in the flame. Make sure that the dryer is not running out of fuel.
Heater 2 Heater Flame Lost	Heater #2 lost flame after it has initially lighted. Adjust the flame sensor so that it is in the flame. Make sure that the dryer is not running out of fuel.
Heater 1 Air Flow Never Detected	The air switch located in the fan #1 electrical box is open due to the fan not turning or the air switch needing adjustment.
Heater 2 Air Flow Never Detected	The air switch located in the fan #2 electrical box is open due to the fan not turning or the air switch needing adjustment.
Heater 1 Air Flow Lost	The air switch located in the fan #1 electrical box has opened after initially closing. The air switch needs adjustment or airflow to or from fan #1 is being restricted.
Heater 2 Air Flow Lost	The air switch located in the fan #2 electrical box has opened after initially closing. The air switch needs adjustment or airflow to or from fan #1 is being restricted.
Heater 1 Air Switch Stuck/Premature	The air switch is closed without fan #1 running. Adjust air switch.
Heater 2 Air Switch Stuck/Premature	The air switch is closed without fan #2 running. Adjust air switch.
Grain Temp Hi-Limit - Digital	The grain temperature has exceeded the Grain Max Temp value on the Temperature menu.

8 Wiring Diagrams

Figure 8-1 AutoFlow Fan/Heater - Modifications for Manual Batch PLC

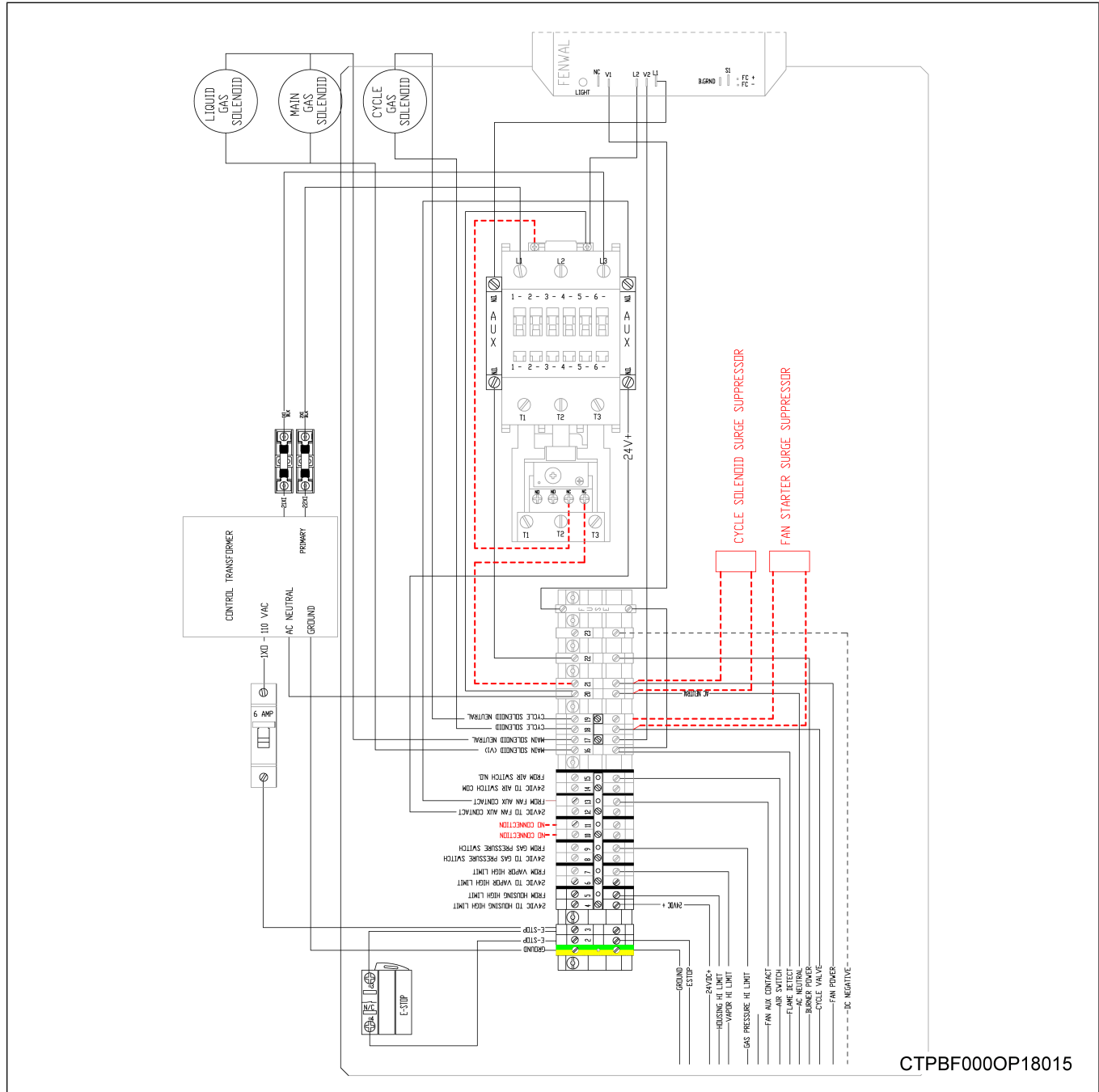

NOTE: Wiring changes are shown with dashed lines.

1. Fan starter overload to be wired in series with fan power wire to starter coil.
2. Surge suppressors must be added as shown. Failure to install suppressors will result in damage to components.

Figure 8-2 E-Stop Circuit PLC Manual Batch

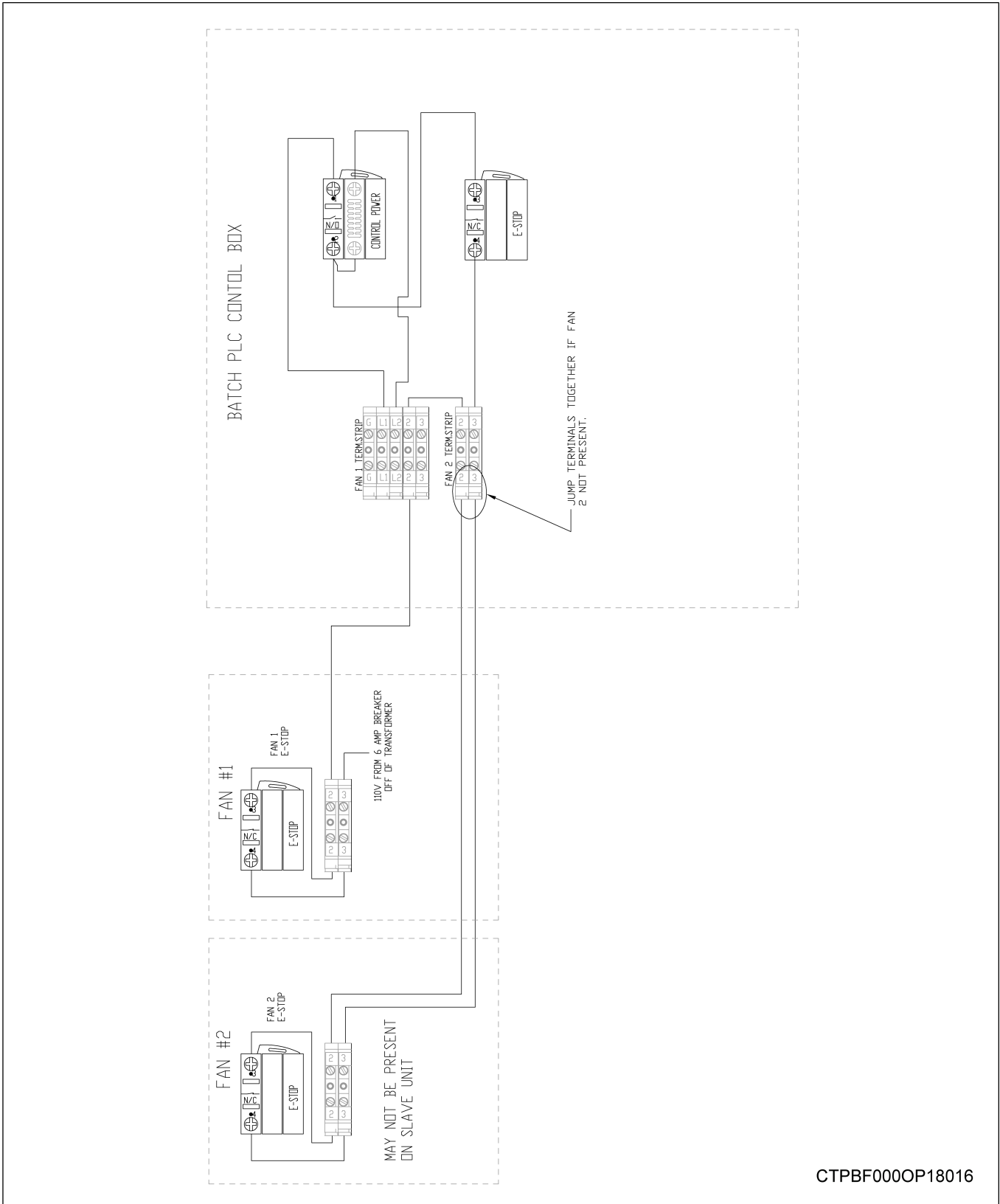

Figure 8-3 Fan 1 Terminal Strips Located In the Top of the Batch PLC System Box

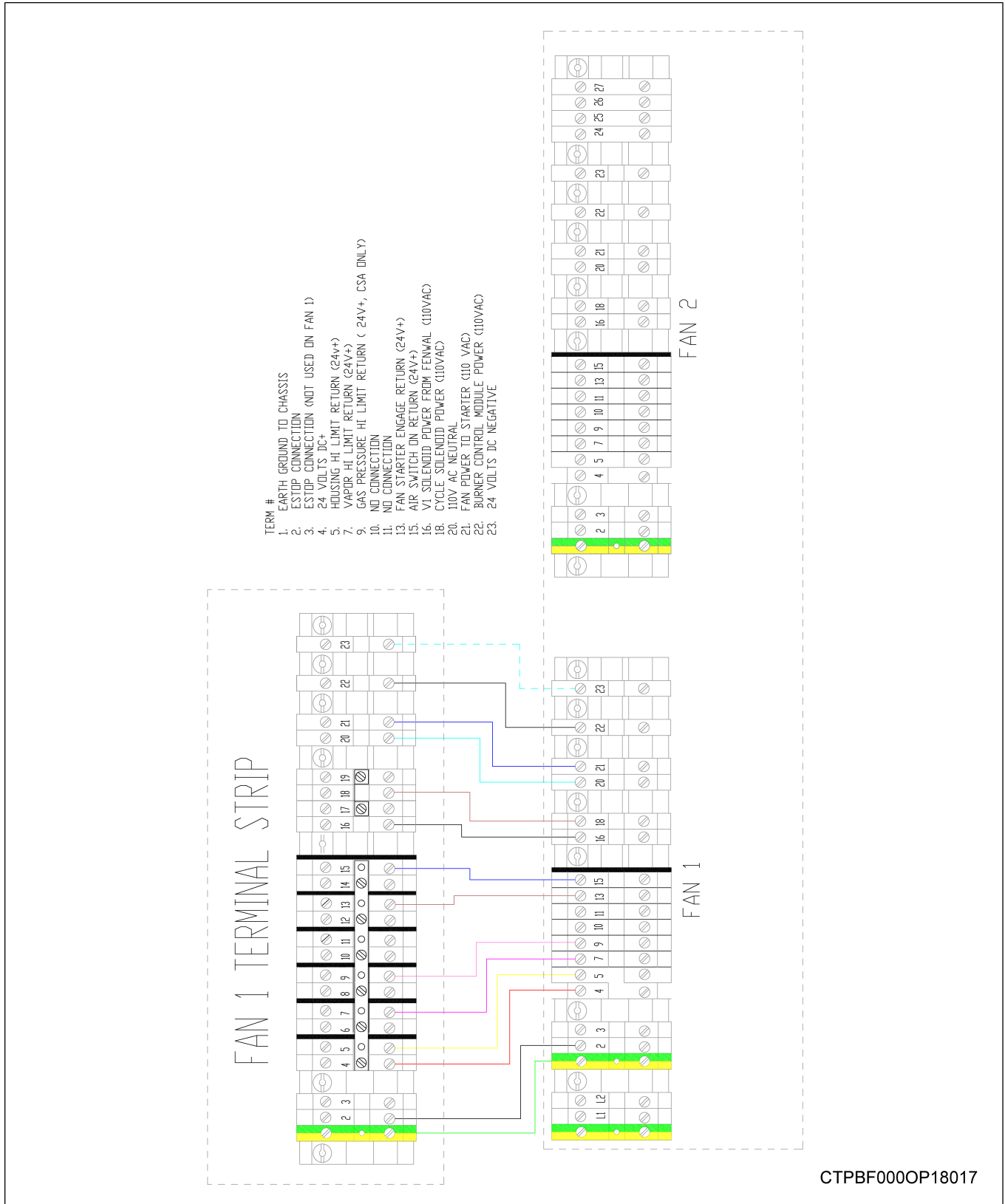

Figure 8-4 Fan 2 Terminal Strips Located In the Top of the Batch PLC System Box

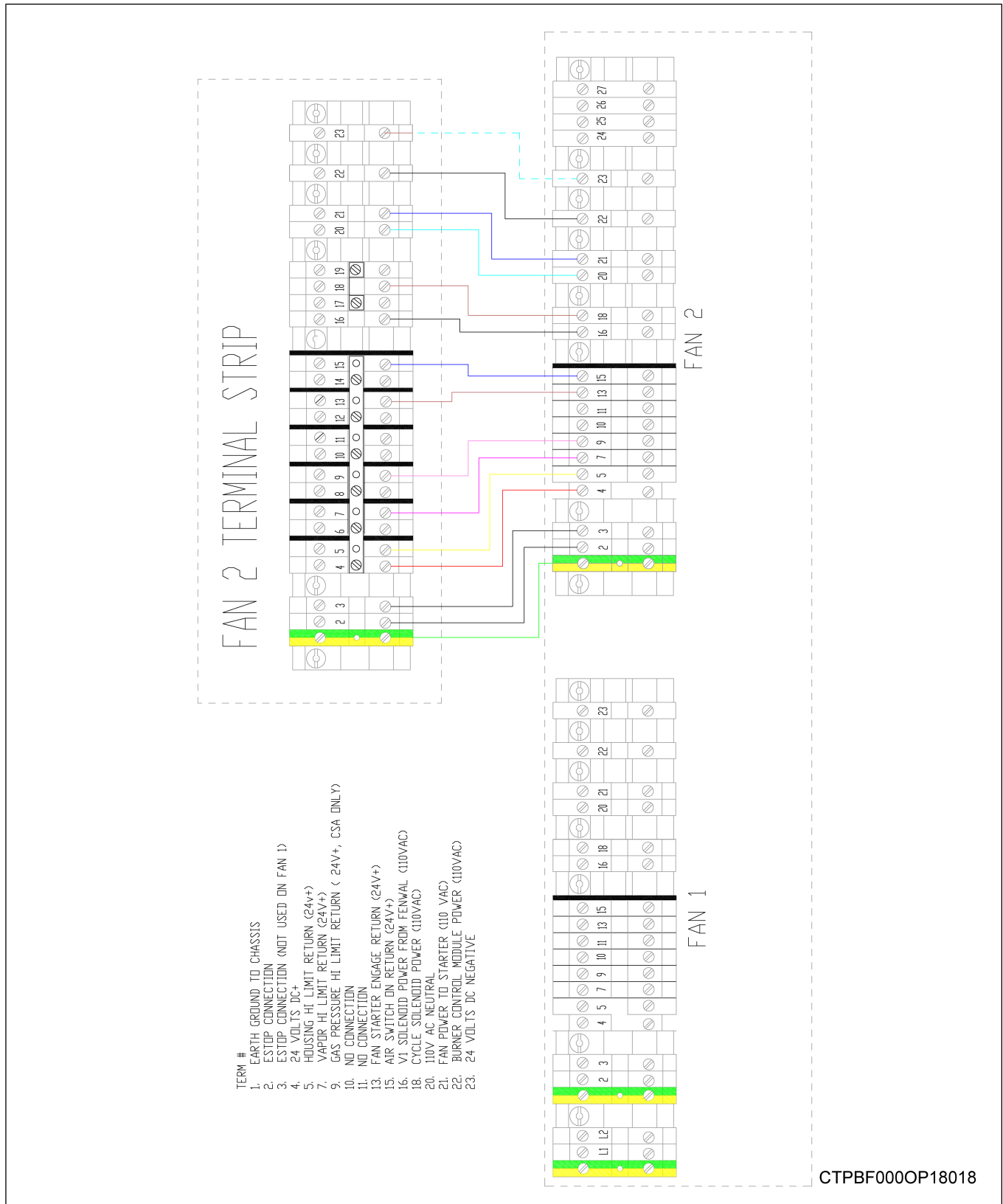
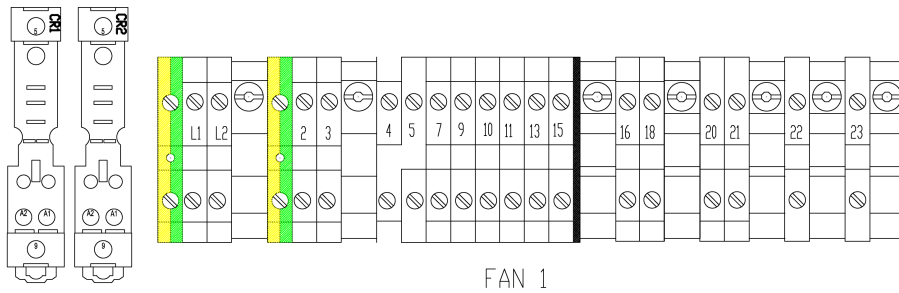

Figure 8-5 Terminal Strips Located In Batch PLC System Box



FAN 1

FAN 1 CONNECTIONS

- TERM #
1. EARTH GROUND TO CHASSIS
 2. ESTOP CONNECTION
 3. ESTOP CONNECTION (NOT USED ON FAN 1)
 4. 24 VOLTS DC+
 5. HOUSING HI LIMIT RETURN (24V+)
 7. VAPOR HI LIMIT RETURN (24V+)
 9. GAS PRESSURE HI LIMIT RETURN (24V+, CSA ONLY)
 10. NO CONNECTION
 11. NO CONNECTION
 13. FAN STARTER ENGAGE RETURN (24V+)
 15. AIR SWITCH ON RETURN (24V+)
 16. V1 SOLENOID POWER FROM FENWAL (110VAC)
 18. CYCLE SOLENOID POWER (110VAC)
 20. 110V AC NEUTRAL
 21. FAN POWER TO STARTER (110 VAC)
 22. BURNER CONTROL MODULE POWER (110VAC)
 23. 24 VOLTS DC NEGATIVE
 24. PLENUM HI LIMIT (+24V)

FAN 2 CONNECTIONS

- TERM #
1. EARTH GROUND TO CHASSIS
 2. ESTOP CONNECTION
 3. ESTOP CONNECTION } JUMP TERMINALS TOGETHER IF FAN 2 IS NOT PRESENT.
 4. 24 VOLTS DC+
 5. HOUSING HI LIMIT RETURN (24V+)
 7. VAPOR HI LIMIT RETURN (24V+)
 9. GAS PRESSURE HI LIMIT RETURN (24V+, CSA ONLY)
 10. NO CONNECTION
 11. NO CONNECTION
 13. FAN STARTER ENGAGE RETURN (24V+)
 15. AIR SWITCH ON RETURN (24V+)
 16. V1 SOLENOID POWER FROM FENWAL (110VAC)
 18. CYCLE SOLENOID POWER (110VAC)
 20. 110V AC NEUTRAL
 21. FAN POWER TO STARTER (110 VAC)
 22. BURNER CONTROL MODULE POWER (110VAC)
 23. 24 VOLTS DC NEGATIVE
 24. PLENUM TEMP SENSOR RETURN (SHIELDED)
 25. PLENUM TEMP SENSOR SUPPLY (SHIELDED)
 26. GRAIN TEMP SENSORS SUPPLY (SHIELDED)
 27. GRAIN TEMP SENSORS RETURN (SHIELDED)

FAN 2

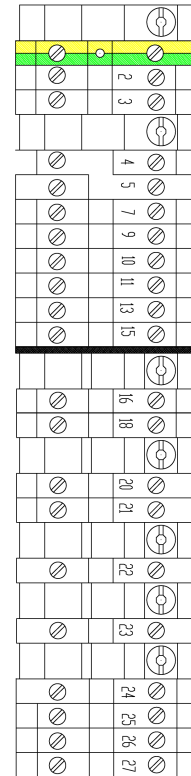

NOTE: THE 4 GRAIN TEMP SENSORS ARE SERIES/PARALLEL CONNECTED. SEE BELOW.

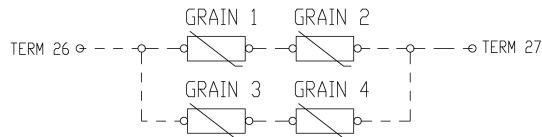

CTPBF000OP18019

Chapter 8: Wiring Diagrams

Figure 8-6 Tower Dryer Control Panel Wiring Diagram

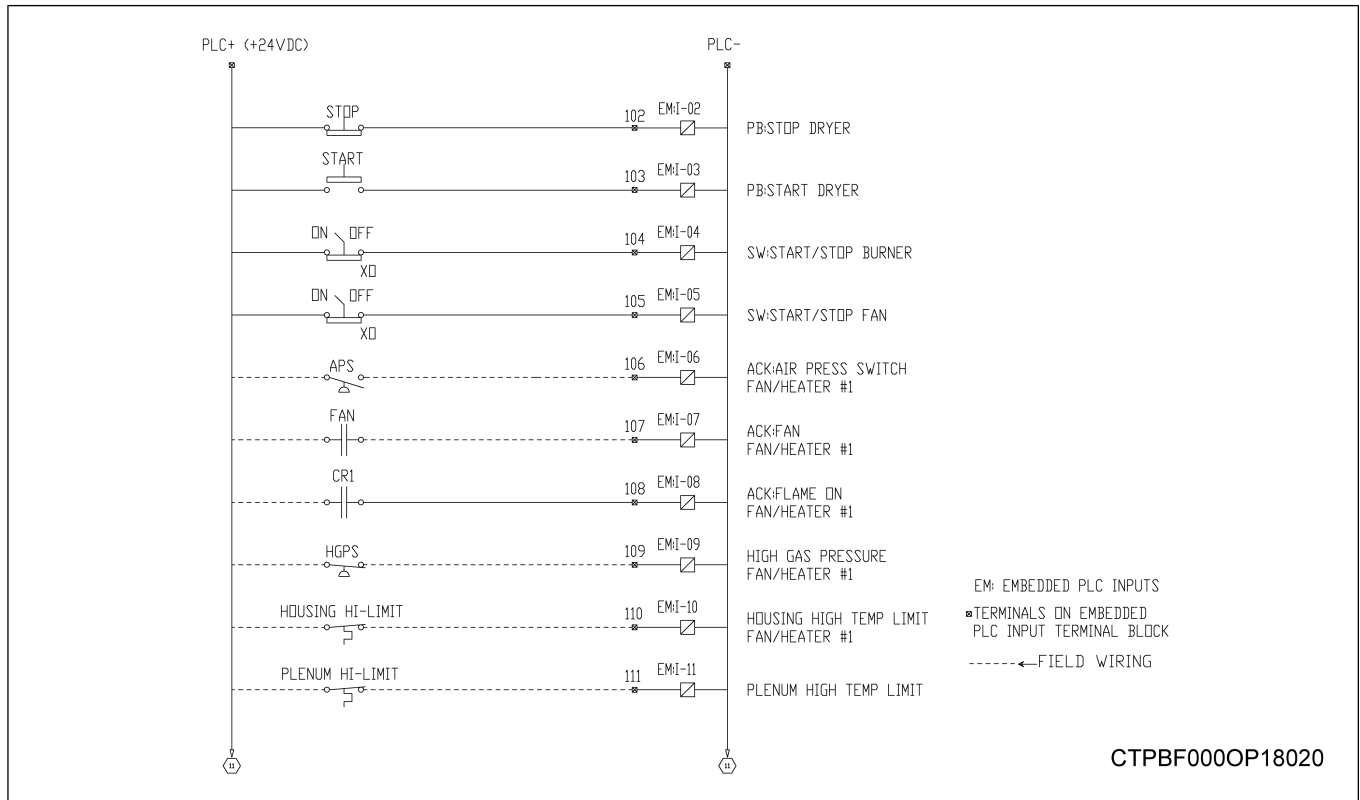

Figure 8-7 Tower Dryer Control Panel Wiring Diagram (Continued)

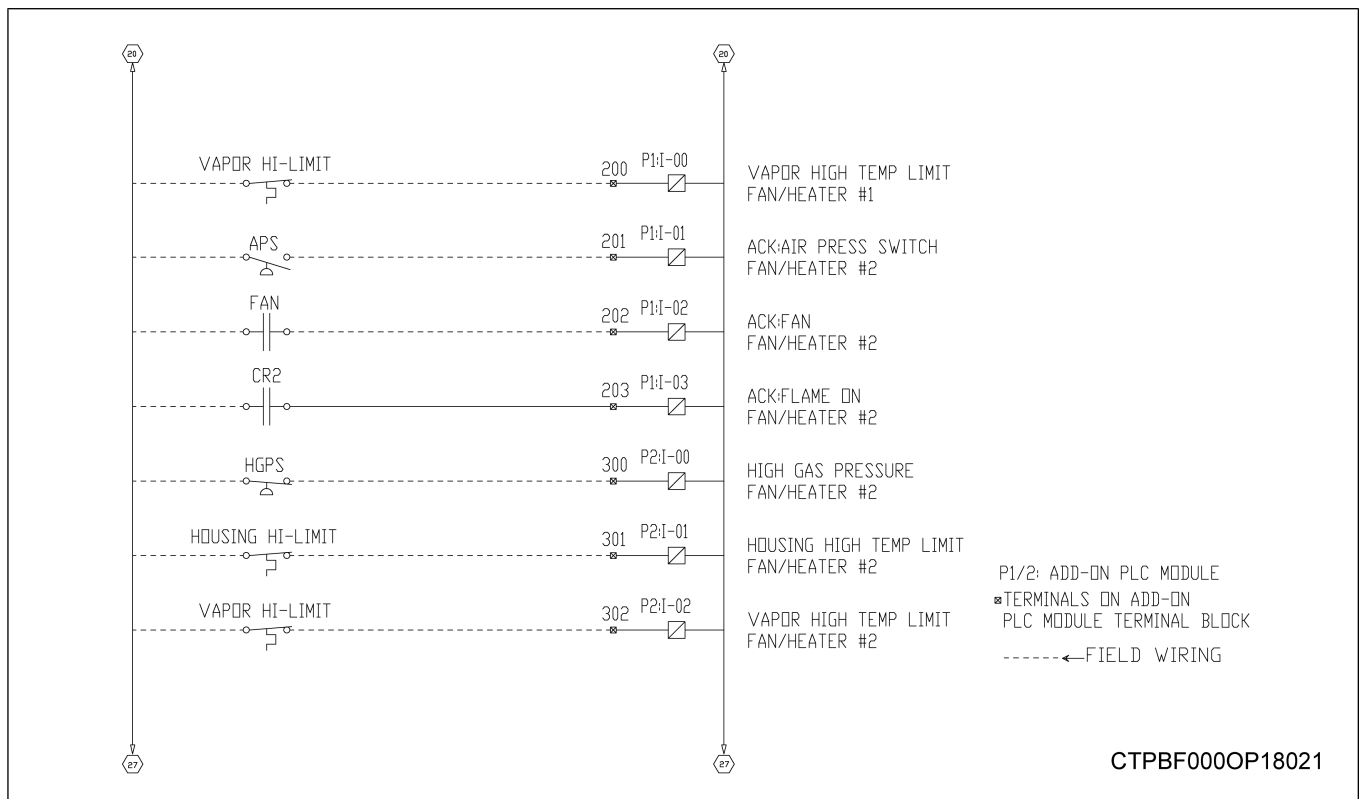

Figure 8-8 Tower Dryer Control Panel Wiring Diagram (Continued)

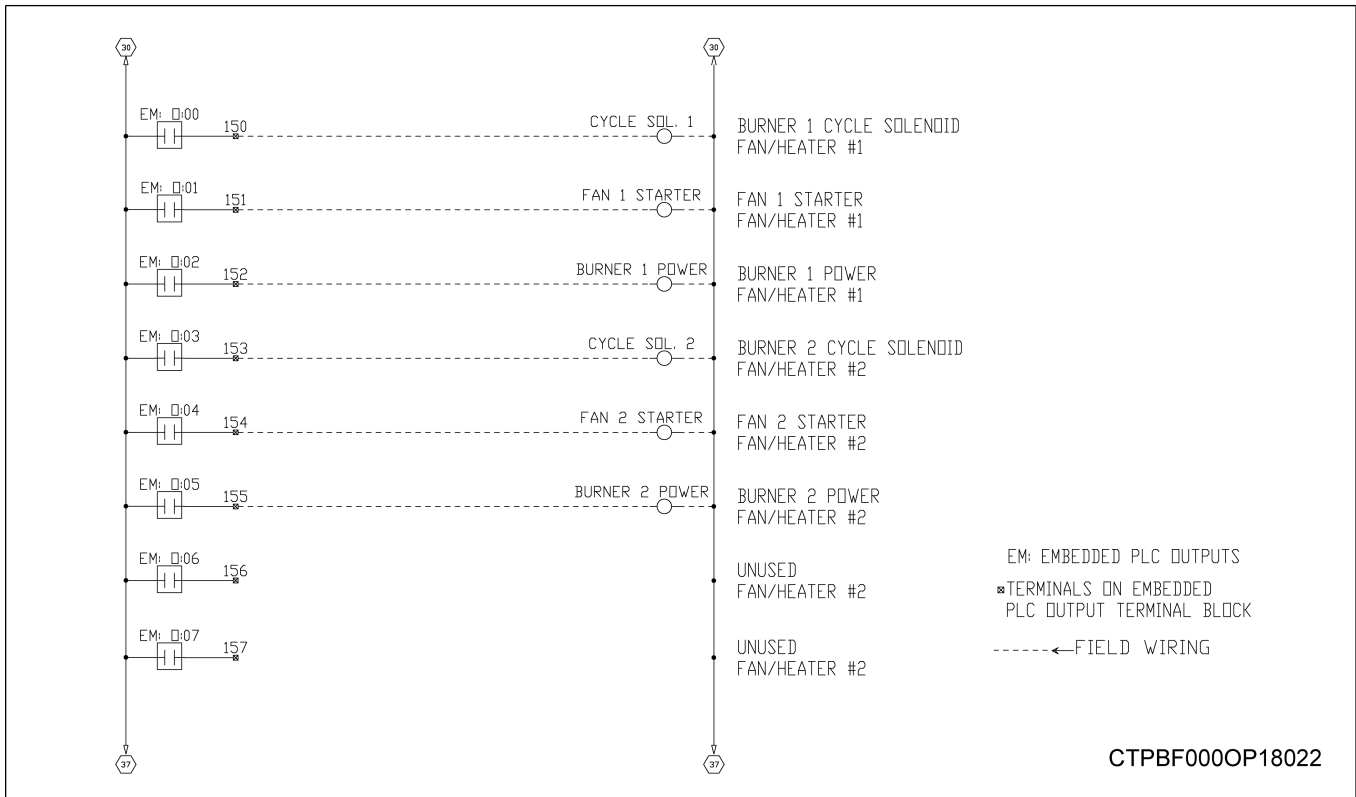

Figure 8-9 Tower Dryer Control Panel Wiring Diagram (Continued)

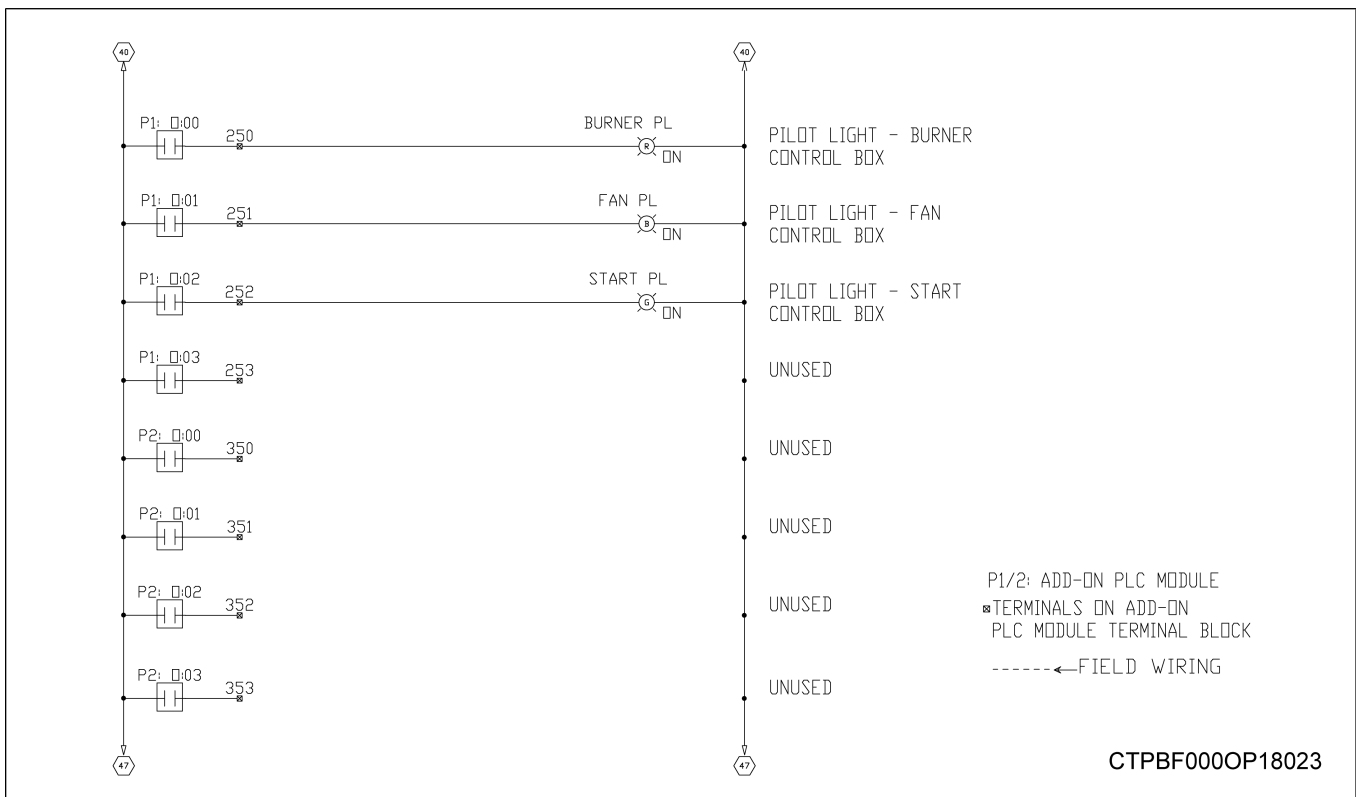

Figure 8-10 Tower Dryer Control Panel Wiring Diagram (Continued)

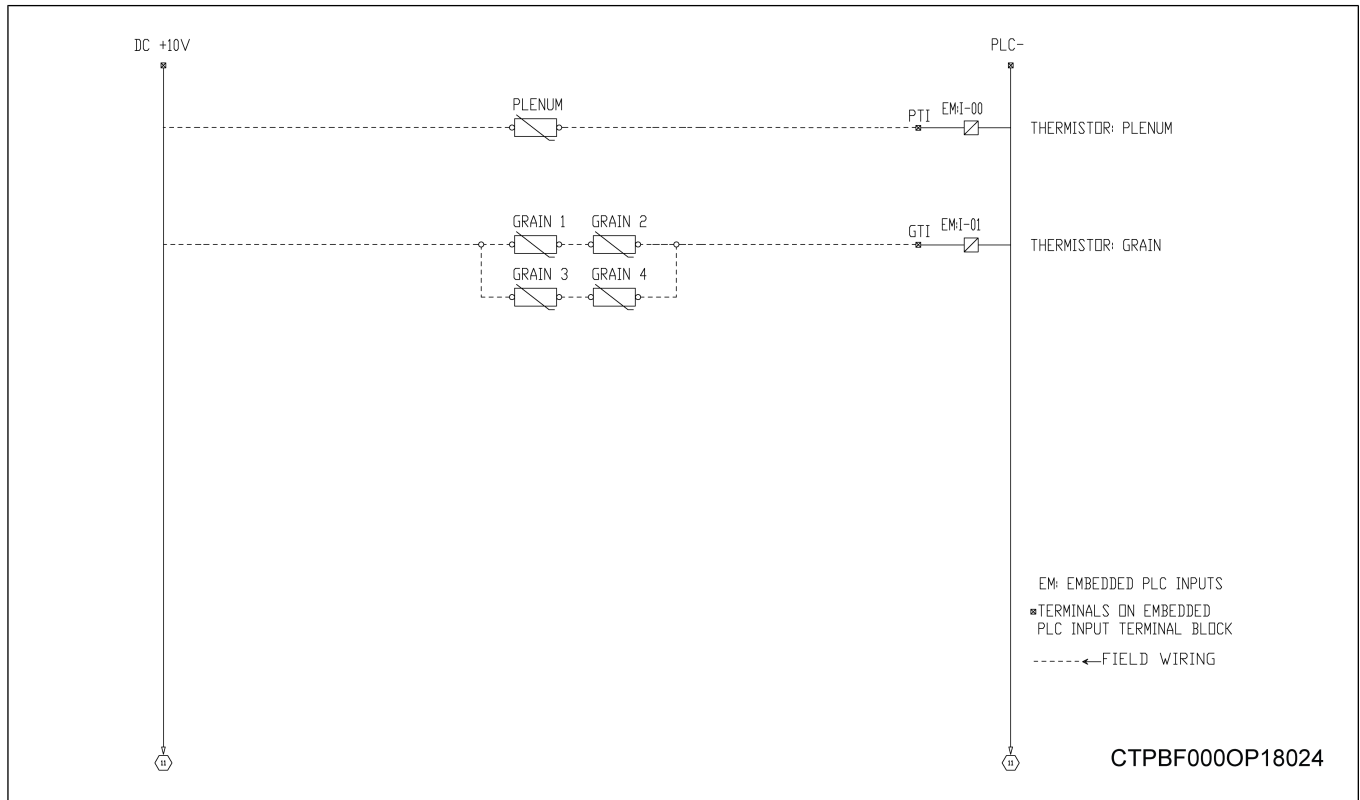
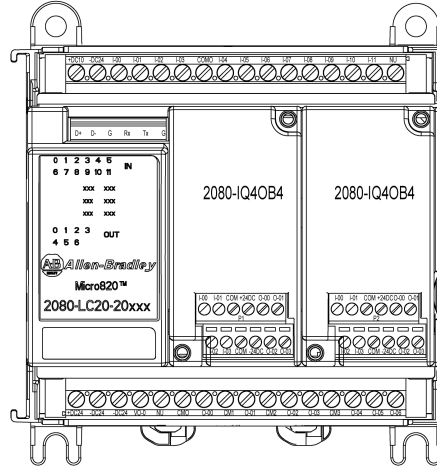
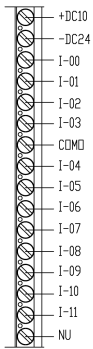

Figure 8-11 Manual Batch PLC TopDry

1	1	EARTH GROUND
2	2	E-STOP CONNECTION
3	3	E-STOP CONNECTION
4	4	+24 VOLTS DC+
5	5	HOUSING HIGH LIMIT RETURN (+24VDC)
6	6	
7	7	VAPOR HI-LIMIT RETURN (+24VDC)
8	8	
9	9	GAS PRESSURE HI-LIMIT RETURN (+24VDC)
10	10	
11	11	
12	12	
13	13	FAN STARTER INTERLOCK RETURN (+24VDC)
14	14	
15	15	AIR SWITCH RETURN (+24VDC)
16	16	PROOF OF FLAME (+24VDC)
17	17	
18	18	CYCLE SOLENOID POWER (+120VAC)
19	19	
20	20	120 AC NEUTRAL
21	21	FAN POWER TO STARTER (120VAC)
22	22	BURNER CONTROL UNIT POWER (120VAC)
23	23	24 VOLT DC NEGATIVE
24	24	PLENUM HIGH TEMP LIMIT



PLC INPUT PINOUT DETAILS



PLC OUTPUT PINOUT DETAILS

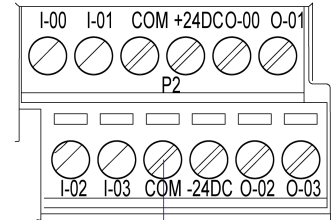
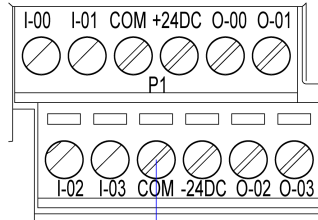
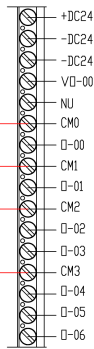

WIRE ID	COLOR	FROM	TO	DESCRIPTION
102	BLUE	EMI-02	STOP	PB/STOP DRIVER
103	BLUE	EMI-03	START	PB/START DRIVER
104	BLUE	EMI-04	HEATER	SW/START/STOP BURNER
105	BLUE	EMI-05	FAN	SW/START/STOP FAN
106	BLUE	EMI-06	FAN/HEATER #1	ACK/AIR PRESS SWITCH
107	BLUE	EMI-07	FAN/HEATER #1	ACK/FAN
108	BLUE	EMI-08	CR1	ACK/FLAME DN
109	BLUE	EMI-09	FAN/HEATER #1	HIGH GAS PRESSURE
110	BLUE	EMI-10	FAN/HEATER #1	HOUSING HIGH TEMP LIMIT
111	BLUE	EMI-11	FAN/HEATER #1	PLENUM HIGH TEMP LIMIT
200	BLUE	P1I-00	FAN/HEATER #1	VAPOR HIGH TEMP LIMIT
201	BLUE	P1I-01	FAN/HEATER #2	ACK/AIR PRESS SWITCH
202	BLUE	P1I-02	FAN/HEATER #2	ACK/FAN
203	BLUE	P1I-03	CR2	ACK/FLAME DN
300	BLUE	P2I-00	FAN/HEATER #2	HIGH GAS PRESSURE
301	BLUE	P2I-01	FAN/HEATER #2	HOUSING HIGH TEMP LIMIT
302	BLUE	P2I-02	FAN/HEATER #2	VAPOR HIGH TEMP LIMIT
150	RED	EMO-00	FAN/HEATER #1	BURNER 1 CYCLE SOLENOID
151	RED	EMO-01	FAN/HEATER #1	FAN 1 STARTER
152	RED	EMO-02	FAN/HEATER #1	BURNER 1 POWER
153	RED	EMO-03	FAN/HEATER #2	BURNER 2 CYCLE SOLENOID
154	RED	EMO-04	FAN/HEATER #2	FAN 2 STARTER
155	RED	EMO-05	FAN/HEATER #2	BURNER 2 POWER
250	BLUE	P1O-00	BURNER PL	PILDT LIGHT - BURNER CONTRL BDX
251	BLUE	P1O-01	FAN PL	PILDT LIGHT - FAN CONTROL BDX
252	BLUE	P1O-02	START PL	PILDT LIGHT - START CONTROL BDX

WIRE ID	COLOR	FROM	TO	DESCRIPTION
400	GREEN	FAN/HEATER #1 (1)	FAN/HEATER #2 (1)	
401	RED	FAN/HEATER #1 (2)	FAN/HEATER #2 (2)	
402	BLUE	FAN/HEATER #1 (4)	FAN/HEATER #2 (4)	
403	RED	FAN/HEATER #2 (16)	CR2 (A1)	
404	WHITE	FAN/HEATER #1 (20)	FAN/HEATER #2 (20)	
405	RED	FAN/HEATER #2 (26)	EMI (+DC10)	
406	BLUE	FAN/HEATER #1 (4)	AB +24V	
407	RED	FAN/HEATER #1 (16)	CR1 (A1)	
408	WHITE	FAN/HEATER #1 (20)	CR1 (A2)	
409	WHITE/BLUE	FAN/HEATER #1 (23)	AB -24V	
410	BLUE	FAN/HEATER #1 (24)	EMI-11	
411	BLUE	AB +DC	CR1 & CR2 (5)	
412	WHITE	CR1 (A2)	L2	
413	RED	FAN/HEATER #2 (3)	E-STOP (4)	
414	RED	E-STOP (3)	CONTROL POWER (4)	
415	RED	L1	AB L	
416	WHITE	L2	AB N	
417	RED	L1	CONTROL POWER (3)	
418	WHITE	L2	CONTROL POWER	
419	RED	AB L	EMO (COM)	
420	BLUE	AB +DC	EMO (+DC24)	
421	BLUE	AB +DC	START & E-STOP (4)	
422	WHITE/BLUE	AB -DC	EMO (-DC24)	
423	WHITE/BLUE	AB -DC	START	
424	WHITE/BLUE	AB -DC	AB POWER	
425	BLUE	AB +DC	AB POWER	
426	WHITE/BLUE	EMI (COM)	EMO (-DC24)	

CTPBF000OP18025

Chapter 8: Wiring Diagrams

Figure 8-12 Manual Batch PLC TopDry (Continued)

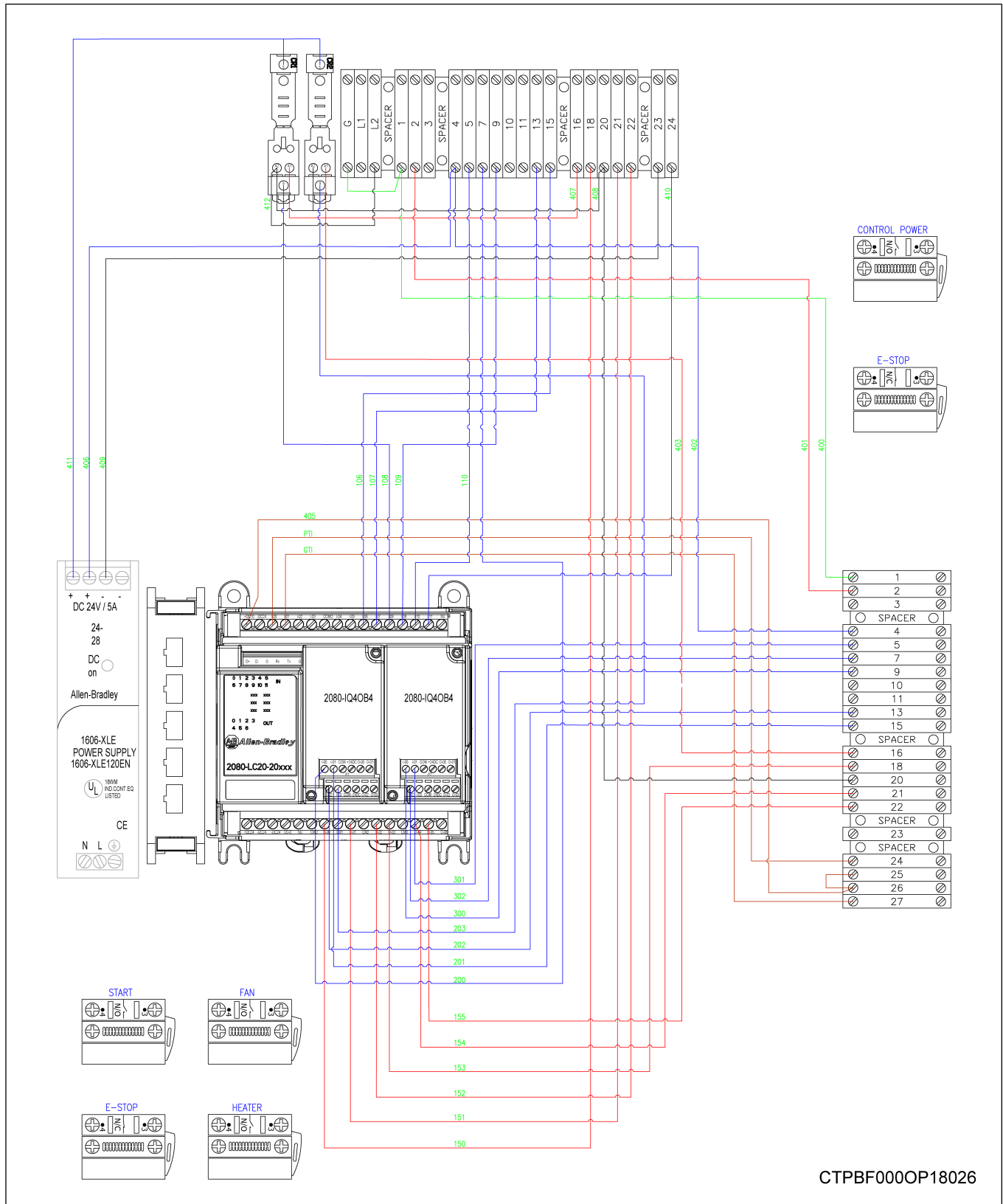

CTPBF000OP18026

Figure 8-13 Manual Batch PLC TopDry (Continued)

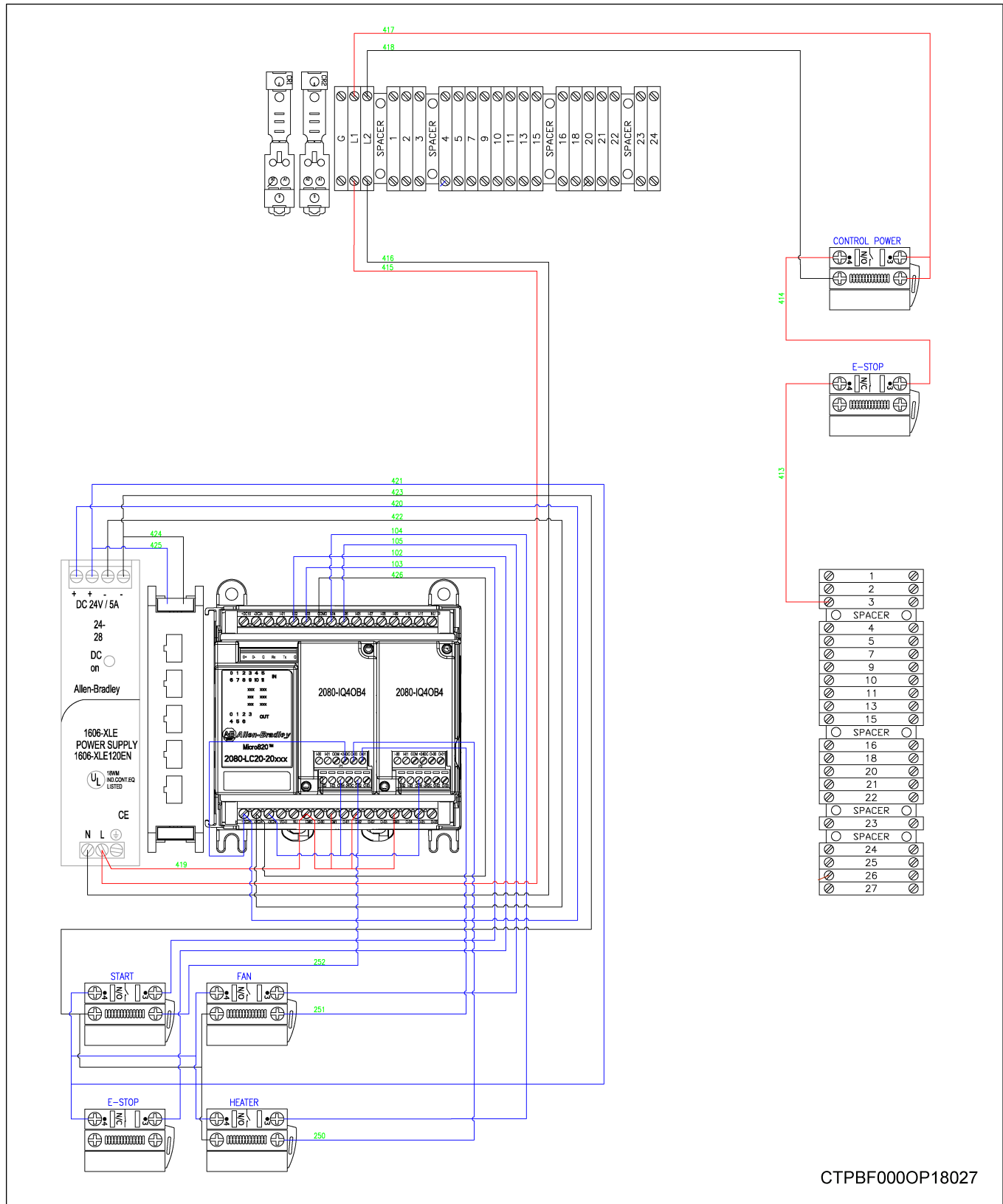

NOTES

Limited Warranty — N.A. Grain Products

The GSI Group, LLC. ("GSI") warrants products which it manufactures, to be free of defects in materials and workmanship under normal usage and conditions for a period of 12 months from the date of shipment (or, if shipped by vessel, 14 months from the date of arrival at the port of discharge). If, in GSI's sole judgment, a product is found to have a defect in materials and/or workmanship, GSI will, at its own option and expense, repair or replace the product or refund the purchase price. This Limited Warranty is subject to extension and other terms as set forth below.

Warranty Enhancements: The warranty period for the following products is enhanced as shown below and is in lieu of (and not in addition to) the above stated warranty period. (Warranty Period is from date of shipment.)

	Product	Warranty Period
Storage	Grain Bin Structural Design • Sidewall, roof, doors, platforms and walkarounds • Flooring (when installed using GSI specified floor support system for that floor) • Hopper tanks (BFT, GHT, NCHT, and FCHT)	5 Years
Conditioning	Dryer Structural Design – (Tower, Portable and TopDry) • Includes (frame, portable dryer screens, ladders, access doors and platforms)	5 Years
	All other Dryer parts including: • Electrical (controls, sensors, switches and internal wiring)	2 Years
	All Non-PTO Driven Centrifugal and Axial Fans	3 Years
	Bullseye Controllers	2 Years
Material Handling	Bucket Elevators Structural Design	5 Years
	Towers Structural Design	5 Years
	Catwalks Structural Design	5 Years
	Accessories (stairs, ladders and platforms) Structural Design	5 Years

Conditions and Limitations:

THERE ARE NO WARRANTIES THAT EXTEND BEYOND THE LIMITED WARRANTY DESCRIPTION SET FORTH HEREIN; SPECIFICALLY, GSI DISCLAIMS ANY AND ALL OTHER WARRANTIES OF ANY KIND, EXPRESS OR IMPLIED, INCLUDING, WITHOUT LIMITATION, WARRANTIES OF MERCHANTABILITY OR FITNESS FOR A PARTICULAR PURPOSE OR USE IN CONNECTION WITH: (I) ANY PRODUCT MANUFACTURED OR SOLD BY GSI, OR (II) ANY ADVICE, INSTRUCTION, RECOMMENDATION OR SUGGESTION PROVIDED BY AN AGENT, REPRESENTATIVE OR EMPLOYEE OF GSI REGARDING OR RELATED TO THE CONFIGURATION, INSTALLATION, LAYOUT, SUITABILITY FOR A PARTICULAR PURPOSE, OR DESIGN OF SUCH PRODUCTS.

The sole and exclusive remedy for any claimant is set forth in this Limited Warranty and shall not exceed the amount paid for the product purchased. This Warranty only covers the value of the warranted parts and equipment, and does not cover labor charges for removing or installing defective parts, shipping charges with respect to such parts, any applicable sales or other taxes, or any other charges or expenses not specified in this Warranty. GSI shall not be liable for any other direct, indirect, incidental or consequential damages, including, without limitation, loss of anticipated profits or benefits. Expenses incurred by or on behalf of a claimant without prior written authorization from the GSI warranty department shall not be reimbursed. This warranty is not transferable and applies only to the original end-user. GSI shall have no obligation or responsibility for any representations or warranties made by or on behalf of any dealer, agent or distributor. Prior to installation, the end-user bears all responsibility to comply with federal, state and local codes which apply to the location and installation of the products.

This Limited Warranty extends solely to products sold by GSI and does not cover any parts, components or materials used in conjunction with the product, that are not sold by GSI. GSI assumes no responsibility for claims resulting from construction defects, unauthorized modifications, corrosion or other cosmetic issues caused by storage, application or environmental conditions. Modifications to products not specifically delineated in the manual accompanying the product at initial sale will void all warranties. This Limited Warranty shall not extend to products or parts which have been damaged by negligent use, misuse, alteration, accident or which have been improperly/inadequately maintained.

Notice Procedure:

In order to make a valid warranty claim a written notice of the claim must be submitted, using the RMA form, within 60 days of discovery of a warrantable nonconformance. The RMA form is found on the OneGSI portal.

Service Parts:

GSI warrants, subject to all other conditions described in this Warranty, Service Parts which it manufactures for a period of 12 months from the date of purchase unless specified in Enhancements above.

This equipment shall be installed in accordance with the current installation codes and applicable regulations which should be carefully followed in all cases. Authorities having jurisdiction should be consulted before installations are made.



1004 E. Illinois St.
Assumption, IL 62510-0020
Phone: 1-217-226-4421
Fax: 1-217-226-4420
www.gsiag.com



GSI is a worldwide brand of AGCO Corporation.