



# 2003 Series 2000 Batch Fan/Heater and Control Installation Instructions

Installation Manual

PNEG-634

Date: 03-21-11

GSI GROUP



PNEG-634

---

**This equipment shall be installed in accordance with the current INSTALLATION CODES FOR GAS BURNING APPLICANCES AND EQUIPMENT, CAN1\_B149.1 and B149.2 or applicable provincial regulations which should be carefully followed in all cases. Authorities having jurisdiction should be consulted before installations are made.**

## Contents

<b>Chapter 1 Safety .....</b>	<b>4</b>
Safety Guidelines .....	4
Fan/Heater Installation and Operating Instructions .....	5
Safety Precautions .....	5
Safety Sign-Off Sheet .....	7
<b>Chapter 2 Decals .....</b>	<b>8</b>
<b>Chapter 3 Installation .....</b>	<b>10</b>
Fan/Heater Mounting .....	10
Control Box Mounting .....	10
Grain Temperature Sensor Installation .....	12
Master Heater Control Box .....	14
Multi-Grain Temperature Sensor .....	15
Plenum High-Limit Installation .....	16
Top Dry Plenum High-Limit Installation .....	17
Plenum Temperature Sensor .....	18
Drying Chamber Overflow Rotary Switch .....	19
Storage Chamber High-Limit Rotary Switch .....	21
Liquid Propane (LP) .....	23
Natural Gas (NG) .....	24
<b>Chapter 4 Electrical Power Supply .....</b>	<b>25</b>
Power Supply .....	25
Transformer and Wiring Voltage Drop .....	25
Machine to Earth Grounding .....	25
Proper Installation of Ground Rod .....	26
Power/Motor Wiring .....	28
Electrical Load Information .....	29
Stand Alone Fan/Heater .....	30
Economy Control Center Interconnect .....	31
Manual Control Center Interconnect .....	32
Master to Slave Interconnect .....	33
Slave to Slave Interconnect .....	34
Rotary Switch and Horn Wiring .....	35
<b>Chapter 5 Warranty .....</b>	<b>37</b>

### Safety Guidelines

This manual contains information that is important for you, the owner/operator, to know and understand. This information relates to protecting **personal safety** and **preventing equipment problems**. It is the responsibility of the owner/operator to inform anyone operating or working in the area of this equipment of these safety guidelines. To help you recognize this information, we use the symbols that are defined below. Please read the manual and pay attention to these sections. Failure to read this manual and its safety instructions is a misuse of the equipment and may lead to serious injury or death.



**This is the safety alert symbol. It is used to alert you to potential personal injury hazards. Obey all safety messages that follow this symbol to avoid possible injury or death.**



**DANGER** indicates a hazardous situation which, if not avoided, will result in death or serious injury.



**WARNING** indicates a hazardous situation which, if not avoided, could result in death or serious injury.



**CAUTION**, used with the safety alert symbol, indicates a hazardous situation which, if not avoided, could result in minor or moderate injury.



**NOTICE** is used to address practices not related to personal injury.



#### **WARNING! BE ALERT!**

Personnel operating or working around equipment should read this manual. This manual must be delivered with the equipment to its owner. Failure to read this manual and its safety instructions is a misuse of the equipment.

## Fan/Heater Installation and Operating Instructions

Thank you for choosing a Top Dry Series 2000 Fan/Heater unit. It is designed to give excellent performance and service for many years.

This manual describes the installation for all standard production Top Dry Series 2000 single fan, multi-fan and 2000 series heater control units. Different models are available for liquid propane or natural gas fuel supply, with either 1 phase 230 volt or 3 phase 208, 220, 380, 460 or 575 volt electrical power.

Our foremost concern is your safety and the safety of others associated with this equipment. We want to keep you as a customer. This manual is to help you understand safe operating procedures and some problems which may be encountered by the operator and other personnel.

As owner and/or operator, it is your responsibility to know what requirements, hazards and precautions exist and to inform all personnel associated with the equipment or in the area. Safety precautions may be required from the personnel. Avoid any alterations to the equipment. Such alterations may produce a very dangerous situation where **SERIOUS INJURY** or **DEATH** may occur.

This equipment shall be installed in accordance with the current installation codes and applicable regulations which should be carefully followed in all cases. Authorities having jurisdiction should be consulted before installations are made.

### Safety Precautions

#### READ THESE INSTRUCTIONS BEFORE OPERATION AND SERVICE SAVE FOR FUTURE REFERENCE

1. Read and understand the operating manual before trying to operate the dryer.
2. Power supply should be **OFF** for service of electrical components. Use **CAUTION** in checking voltage or other procedures requiring power to be **ON**.
3. Check for gas leaks at all gas pipe connections. If any leaks are detected, **DO NOT** operate the dryer. Shut down and repair before further operation.
4. **NEVER** attempt to operate the dryer by jumping or otherwise bypassing any safety devices on the unit.
5. Set pressure regulator to avoid excessive gas pressure applied to burner during ignition and when burner is in operation. **DO NOT** exceed maximum recommended drying temperature.
6. Keep the dryer clean. **DO NOT** allow fine material to accumulate in the plenum or drying chamber.
7. Use **CAUTION** in working around high speed fans, gas burners, augers and auxiliary conveyors which can **START AUTOMATICALLY**.
8. **DO NOT** operate in any area where combustible material will be drawn into the fan.
9. **BEFORE** attempting to remove and re-install any propeller, make certain to read the recommended procedure listed within the servicing section of the manual.
10. Clean grain is easier to dry. Fine material increases resistance to airflow and requires removal of extra moisture.

**This product is intended for the use of grain handling only. Any other use is considered a misuse of the product.**

**Some edges of the product components can be sharp. It is recommended that each component of this product be examined to determine if there are any safety considerations to be taken. Any and all necessary personal protective equipment should be worn at all times when handling, assembling, installing and operation of the product and/or components. Guards are removed for illustration purpose only. All guards must be in place before/during operation.**

## 1. Safety

---

### Use Caution in the Operation of this Equipment

This dryer is designed and manufactured with operator safety in mind. However, the very nature of a grain dryer having a gas burner, high voltage electrical equipment and high speed rotating parts, presents hazards to personnel which cannot be completely safeguarded against without interfering with the efficient operation of the dryer and reasonable access to its components.

Use extreme caution in working around high speed fans, gas-fired heaters, augers and auxiliary conveyors, which may start without warning when the dryer is operating on automatic control.



***Keep the dryer clean. Do not allow fine material to accumulate in the plenum chamber or surrounding the outside of the dryer.***

Continued safe, dependable operation of automatic equipment depends, to a great degree, upon the owner. For a safe and dependable drying system, follow the recommendations within this manual and make it a practice to regularly inspect the unit for any developing problems or unsafe conditions.

Take special note of the [Safety Precautions on Page 5](#) before attempting to operate the dryer.



## 2. Decals

The GSI recommends contacting your local power company and having a representative survey the installation so the wiring is compatible with their system and adequate power is supplied to the unit.

Safety decals should be read and understood by all people in the grain handling area. The rotating blade, fire warning decals and voltage danger decal must be displayed on the fan can. The decal DC-GBC-1A shown [on Page 9](#) should be present on the inside bin door cover of the 2 ring door, 24" porthole door cover and the roof manway cover.

If a decal is damaged or is missing contact:


### GSI Decals

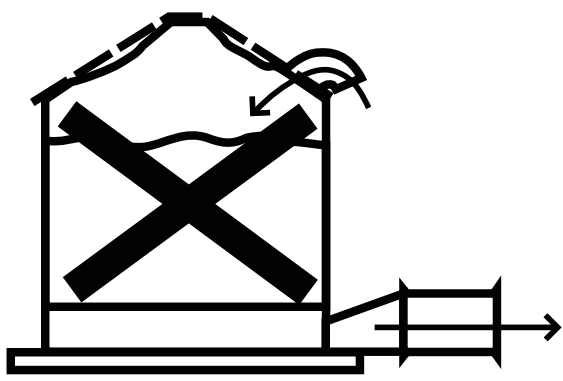
1004 E. Illinois St.  
Assumption, IL. 62510  
Phone: 1-217-226-4421

A free replacement will be sent to you.

## Roof Damage Warning and Disclaimer

The manufacturer does not warrant any roof damage caused by excessive vacuum or internal pressure from fans or other air moving systems. Adequate ventilation and/or "makeup air" devices should be provided for all powered air handling systems. The manufacturer does not recommend the use of downward flow systems (suction). Severe roof damage can result from any blockage of air passages. Running fans during high humidity/cold weather conditions can cause air exhaust or intake ports to freeze.

 **CAUTION!**




**Excessive vacuum (or pressure) may damage roof. Use positive aeration system. Make sure all roof vents are open and unobstructed. Start roof fans when supply fans are started. Do not operate when conditions exist that may cause roof vent icing.**

DC-969



**⚠ DANGER**



**HIGH VOLTAGE.**

- Will cause serious injury or death.
- Lockout power before servicing.

DC-1224

DC-1224

**⚠ DANGER**

		
Rotating augers will kill or dismember.	Flowing material will trap and suffocate.	Crusted material will collapse and suffocate.

**Keep clear of all augers.  
DO NOT ENTER this bin!**

If you must enter the bin:

1. Shut off and lock out all power.
2. Use a safety harness and safety line.
3. Station another person outside the bin.
4. Avoid the center of the bin.
5. Wear proper breathing equipment or respirator.

**Failure to heed these warnings will result in serious injury or death.**

DC-GBC-1A

DC-GBC-1A



**⚠ WARNING**

Flame and pressure beyond door can cause serious injury. Do not operate with service door removed. Keep head and hands clear.

DC-1227

DC-1227



**⚠ WARNING**

Stay clear of rotating blade. Blade could start automatically. Can cause serious injury. Disconnect power before servicing.

DC-1225

DC-1225

### 3. Installation

## Fan/Heater Mounting

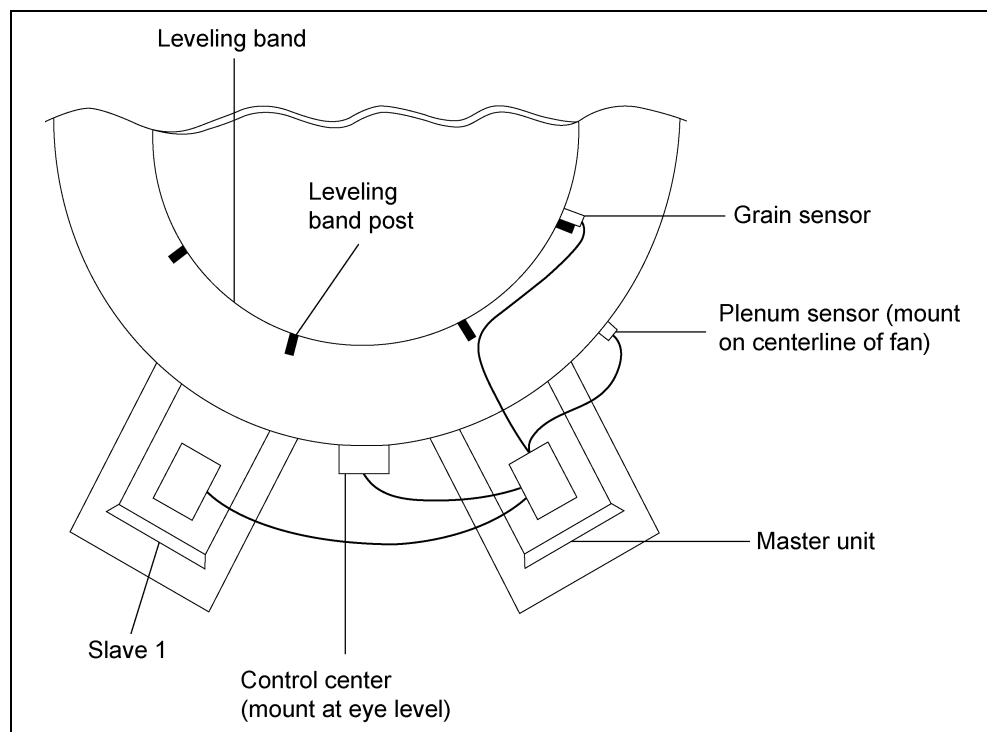
1. Inspect the fan platform for proper installation per instructions in the Top Dry erection manual.
2. Raise the Top Dry Fan/Heater units to the platform. Use the [Table below](#) to determine the height of the platform from the base of the Top Dry unit.
3. Mount the Top Dry Fan/Heater units to the bin entrance sheets. Fan legs should set on the platform.

**Top Dry Bin Eave Height**

# of Rings	Eave Height
5	18'-5"
6	22'-1"
7	25'-9"
8	29'-5"
9	33'-1"
10	36'-9"
11	40'-5"

## Control Box Mounting

1. Mount control boxes at eye level, regardless of whether using the manual control center of the econo control center. Make sure to have the control boxes mounted so that the fan and heater unit(s) are in view.
2. Keep in mind that wire will be used to interconnect the control center with the fan and heater unit(s).
3. Use the hole pattern in [Figure 3C on Page 11](#) to drill holes for mounting the control box.



**Figure 3A 2 Fan Top Dry Configuration**

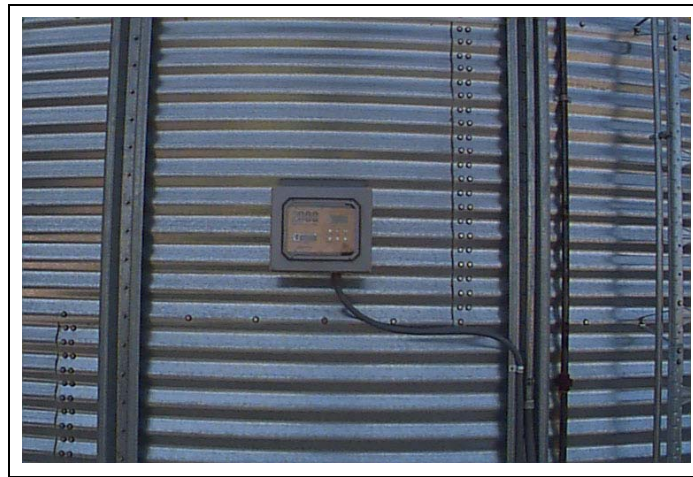


Figure 3B Control Box Mounted on Bin

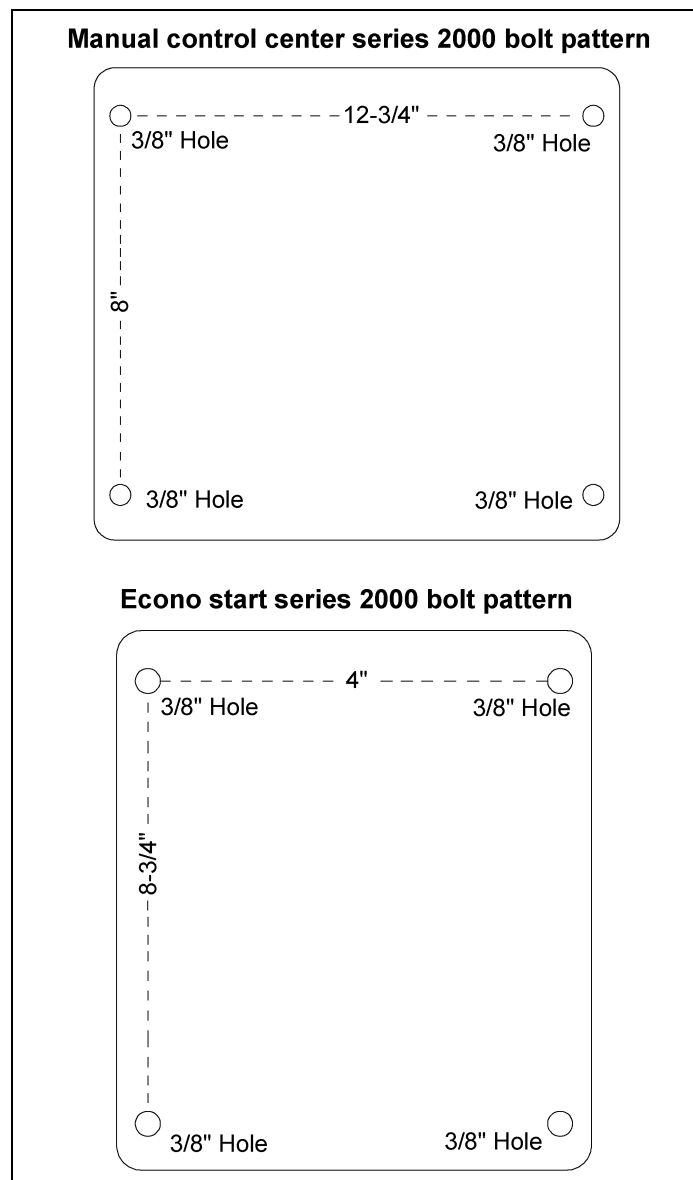


Figure 3C Illustration of the bolt pattern for the manual and econo control center.

### 3. Installation

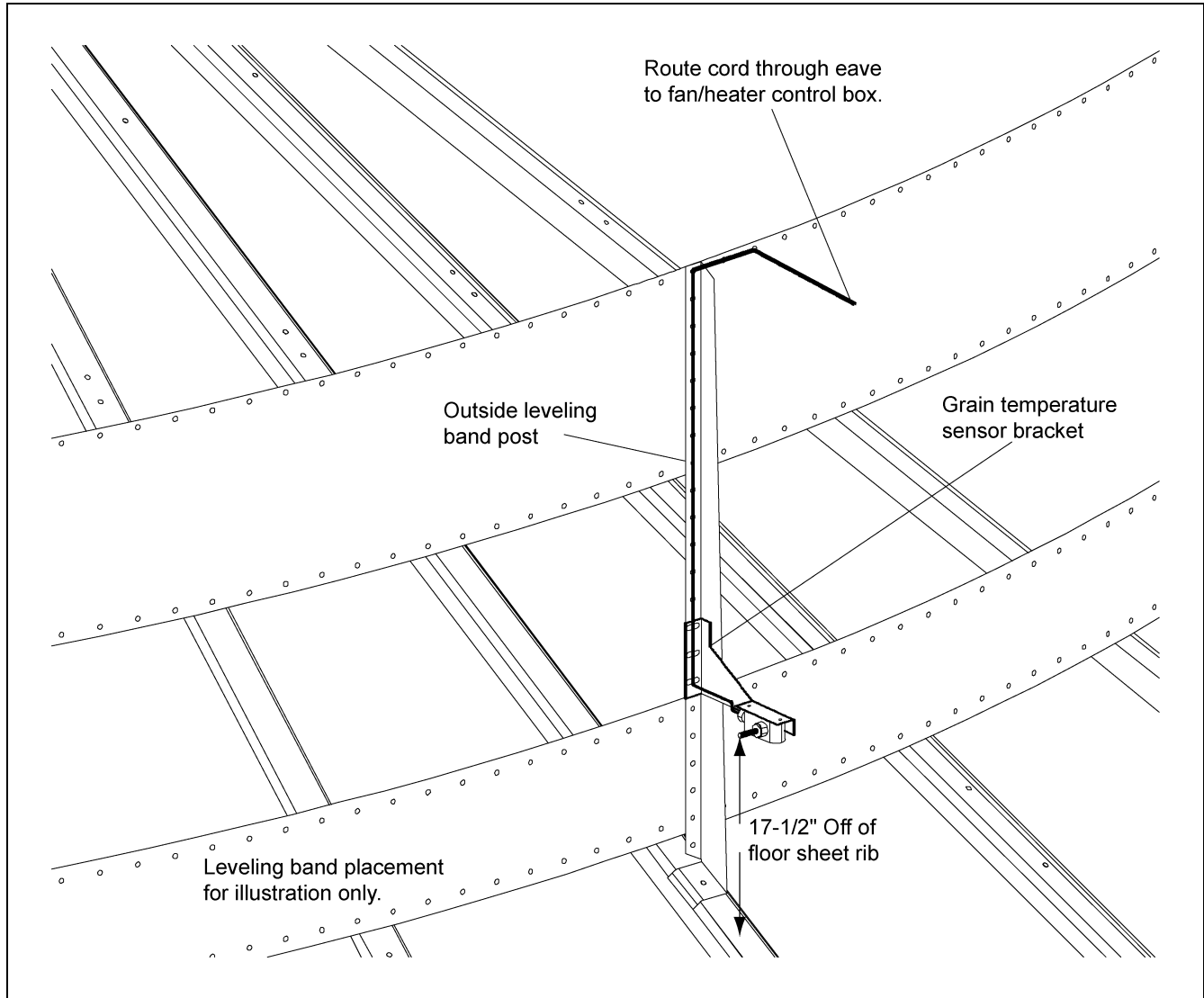
## Grain Temperature Sensor Installation

1. Remove the two (2) wires attached to the grain temperature sensor connected to terminal #22 and terminal #23 in the fan control box.
2. Mount the grain temperature sensor bracket on an outside leveling band post. *(See Figure 3E on Page 13.)*
3. Mount the brackets with bin bolts so that the sensor is 17-1/2" above the floor sheet rib.
4. Wire tie the cord so that it feeds up the leveling band post and across the top leveling band.
5. Route the cord through the space between the roof and the top sidewall sheet.
6. Route the cord back into the fan control box.
7. Install the two (2) wires from the cord into terminal #22 and terminal #23. *(See Figure 3F on Page 14.)*



**Figure 3D** Grain Temperature Sensor Bracket Mounted on Leveling Band Post

## Grain Temperature Sensor Installation (Continued)



**Figure 3E** *Illustration of grain temperature sensor mounted on outside leveling band post.*

3. Installation

Master Heater Control Box

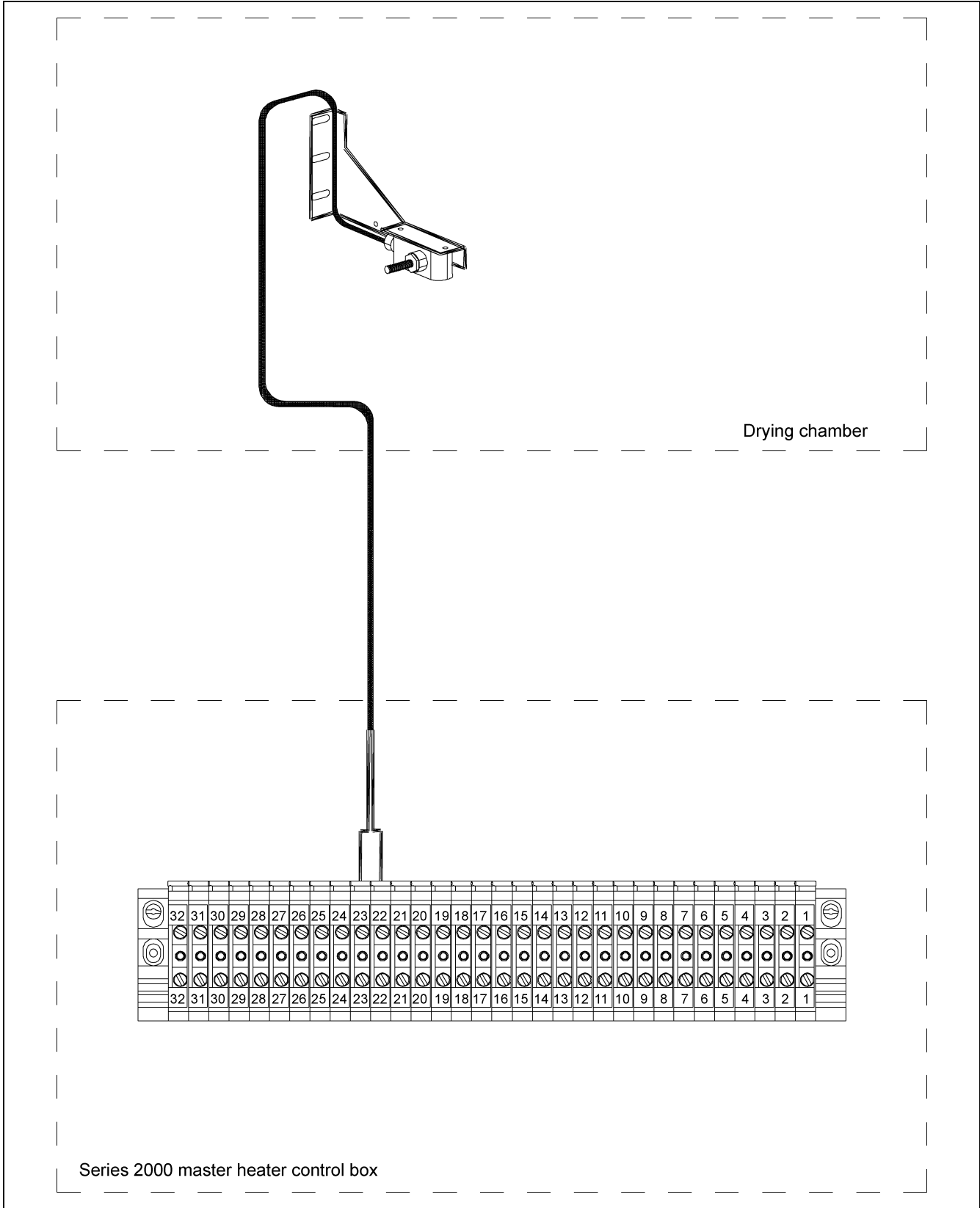
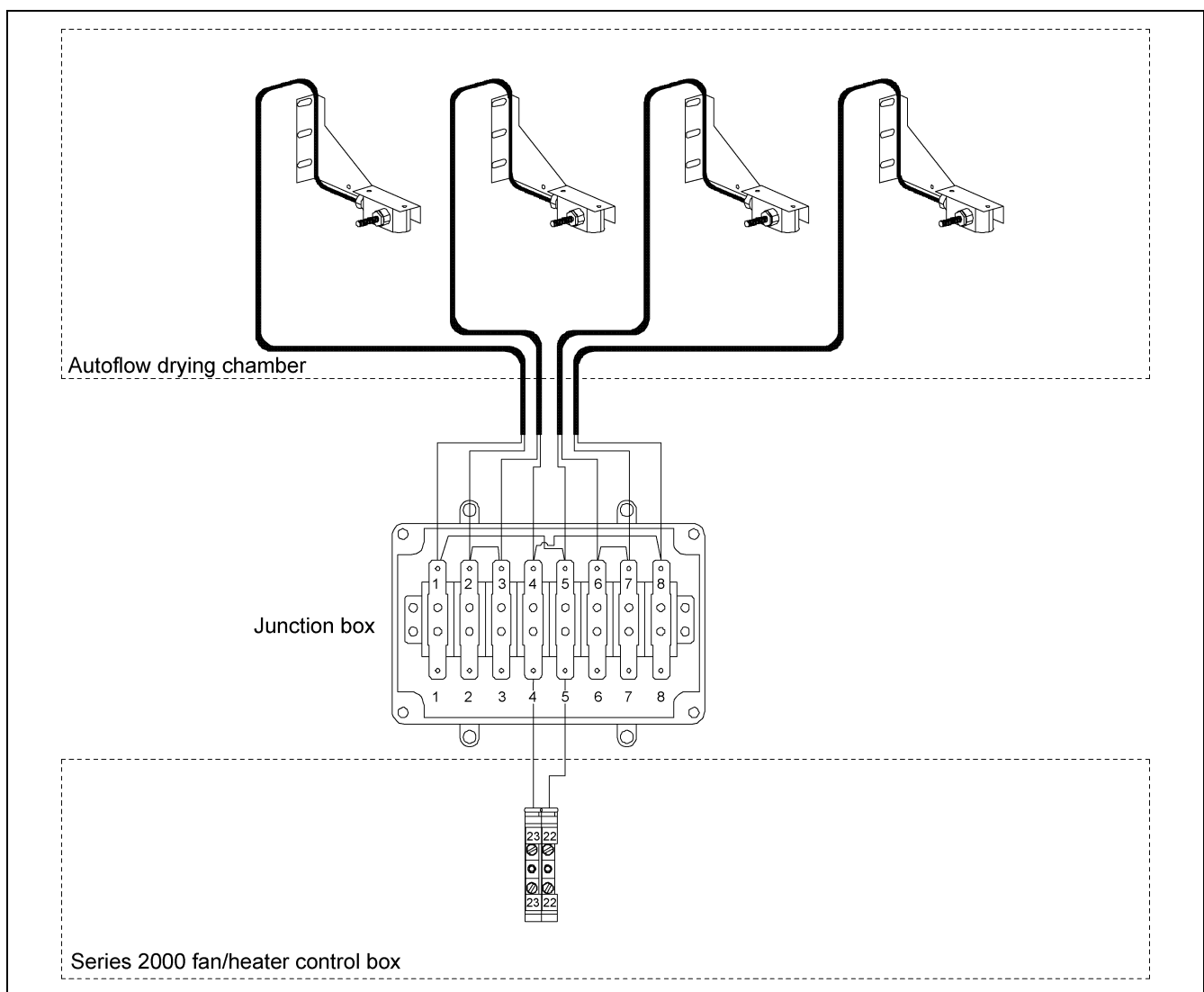


Figure 3F Illustration of the connection between the master heater control box and the drying chamber.

## Multi-Grain Temperature Sensor

1. Remove the two (2) wires attached to the grain temperature sensor connected to terminal #22 and terminal #23 in the fan control box.
2. Mount the four (4) grain temperature sensor brackets evenly around the drying chamber on outside leveling band posts. (See Figure 3E on Page 13.)
3. Mount the bracket with bin bolts so the sensor is 17-1/2" above the floor sheet rib.
4. Wire tie the cords so they feed up the leveling band post and across the top leveling band.
5. Route the cords through the space between the roof and the top sidewall sheet. There should be enough on all temperature sensor brackets to exit the drying chamber at the same place.
6. Route the cords into the junction box after the junction box has been mounted to the bin.
7. Wire the four (4) temperature sensors. (See Figure 3G.)



**Figure 3G** Illustration of the connection between the master heater control box and multiple sensors in the drying chamber.

# Plenum High-Limit Installation

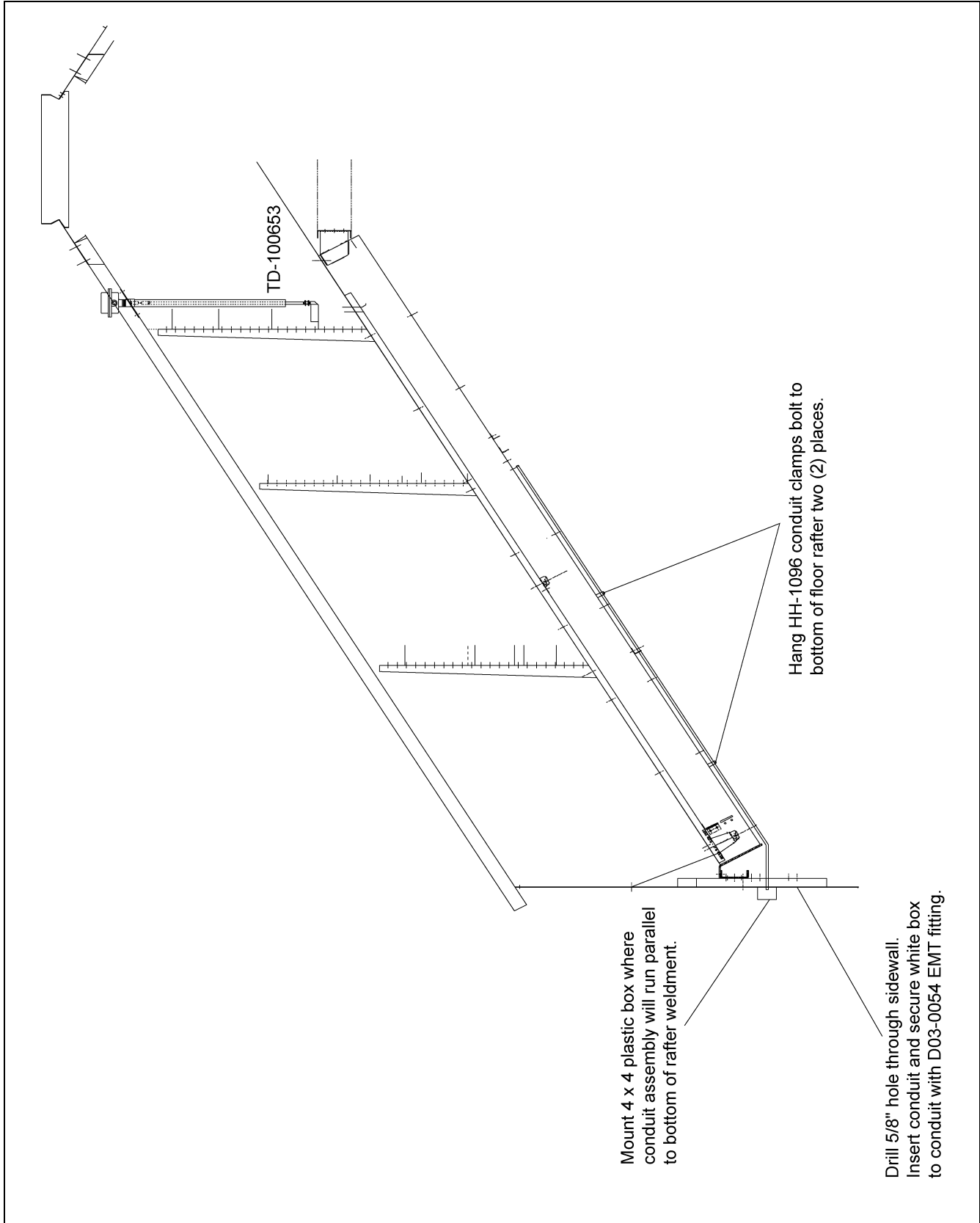


Figure 3H 30' Top Dry Layout Plenum High-Limit



## Top Dry Plenum High-Limit Installation

1. Assemble two (2) pieces of conduit together with coupler.
2. Mount conduit clamps to conduit assembly.
3. Locate conduit assembly on the bottom of a rafter at least 2' to one side of the fan entrance.  
Do not install between 2 fan entrances.
4. Mark bin wall where conduit will pass through and drill a hole just large enough to allow the conduit to pass through. Seal hole with caulking when complete.
5. Install white PVC box assembly on outside of bin wall.
6. Insert 10' capillary into conduit assembly.
7. Connect SJO cord to high-limit and connect wires to terminal #20 and terminal #21 on the master fan terminal strip. These terminals are J7-08 and J7-03.

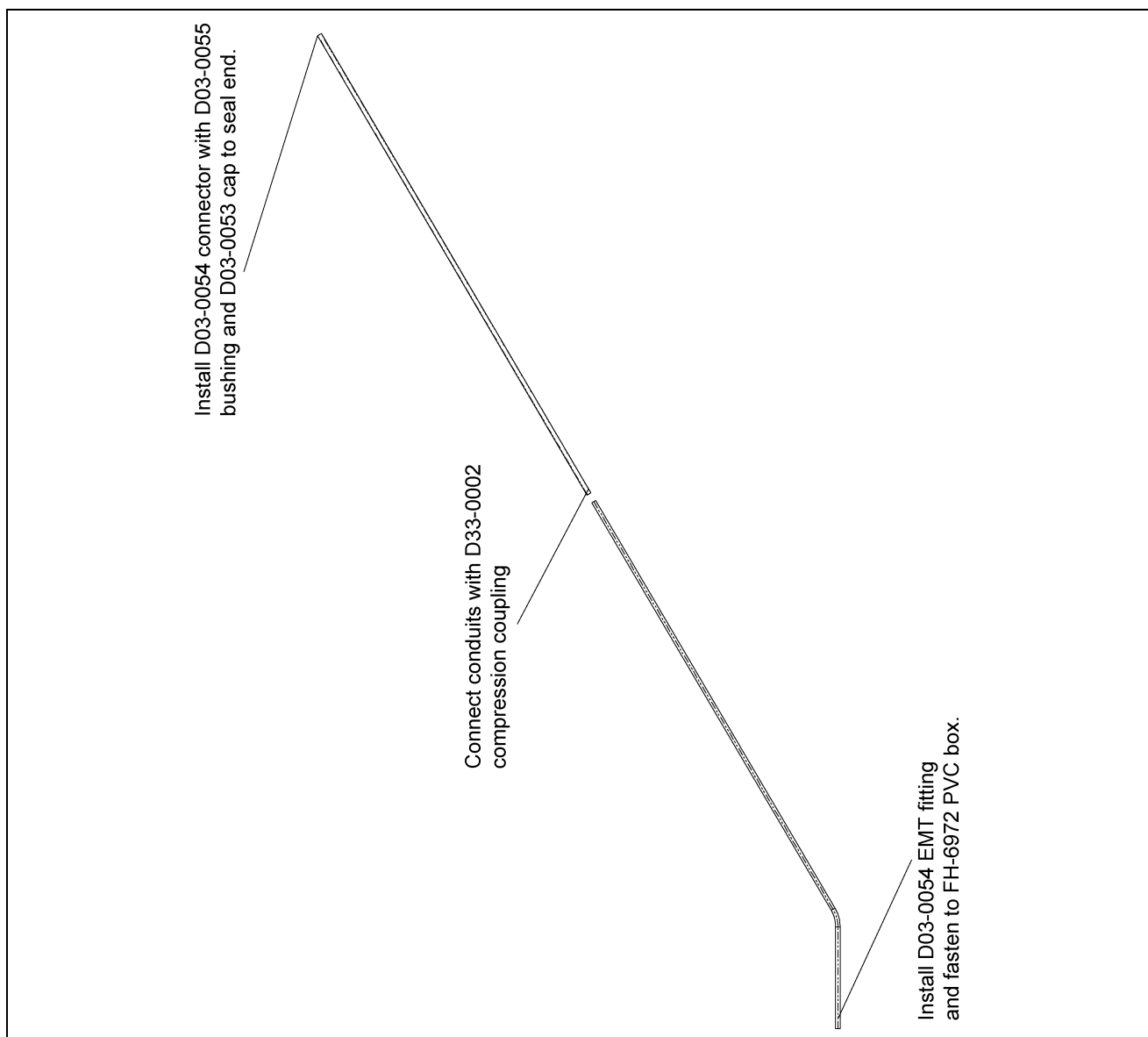


Figure 3I

### 3. Installation

## Plenum Temperature Sensor

The plenum temperature sensor is the small grey PVC junction box attached by a cord to the fan/heater control box on the master fan/heater unit.

1. On the right side of the far right fan/heater, drill one 3/4" hole even with the fan/heater unit in a valley on the bin sidewall.
2. Insert the probe through the 3/4" hole.
3. Position the housing so the cord exits the housing horizontally and the tabs fall on the sidewall peaks.
4. Use two (2) self-drilling screws to mount the housing to the bin sidewall.
5. Caulk between the housing and the sidewall to seal the gaps.

**IMPORTANT:** *If the Top Dry is a 2 fan unit, do not mount the plenum temperature sensor between the two (2) fan/heater units.*



**Figure 3J** *Plenum temperature sensor on the bin sidewall.*

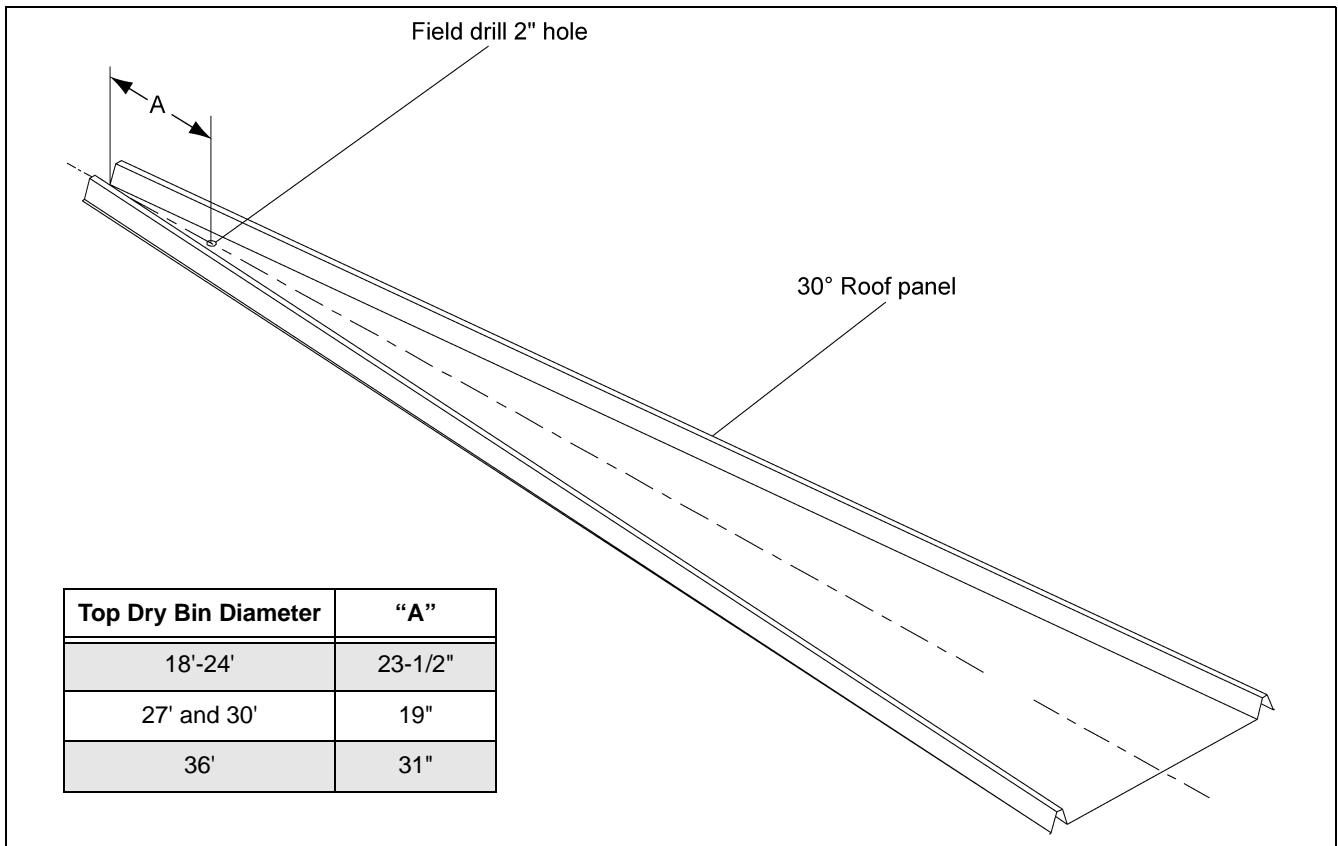
## Drying Chamber Overflow Rotary Switch

1. Drill a 2" diameter hole through the roof panel at the location shown *in Figure 3L on Page 20*.
2. Use the mounting plate as a pattern and drill four (4) 3/8" holes through the roof panel at the switch location so the plate can be bolted to the roof.
3. Attach the flex coupling to the rotary switch power pack using a roll pin.
4. Apply teflon tape or pipe sealant (not included) to the rotary switch power pack threads and thread the rotary switch power pack into the mounting plate coupling.
5. Make sure the conduit hole is at right angles with the roof panel ribs or facing toward the eave.
6. Caulk the underside of the mounting plate and on all sides of the 2" hole.
7. Bolt the assembly to the roof panel.
8. Attach the 3 vane paddle to the flex coupling as shown *in Figure 3M on Page 20*.

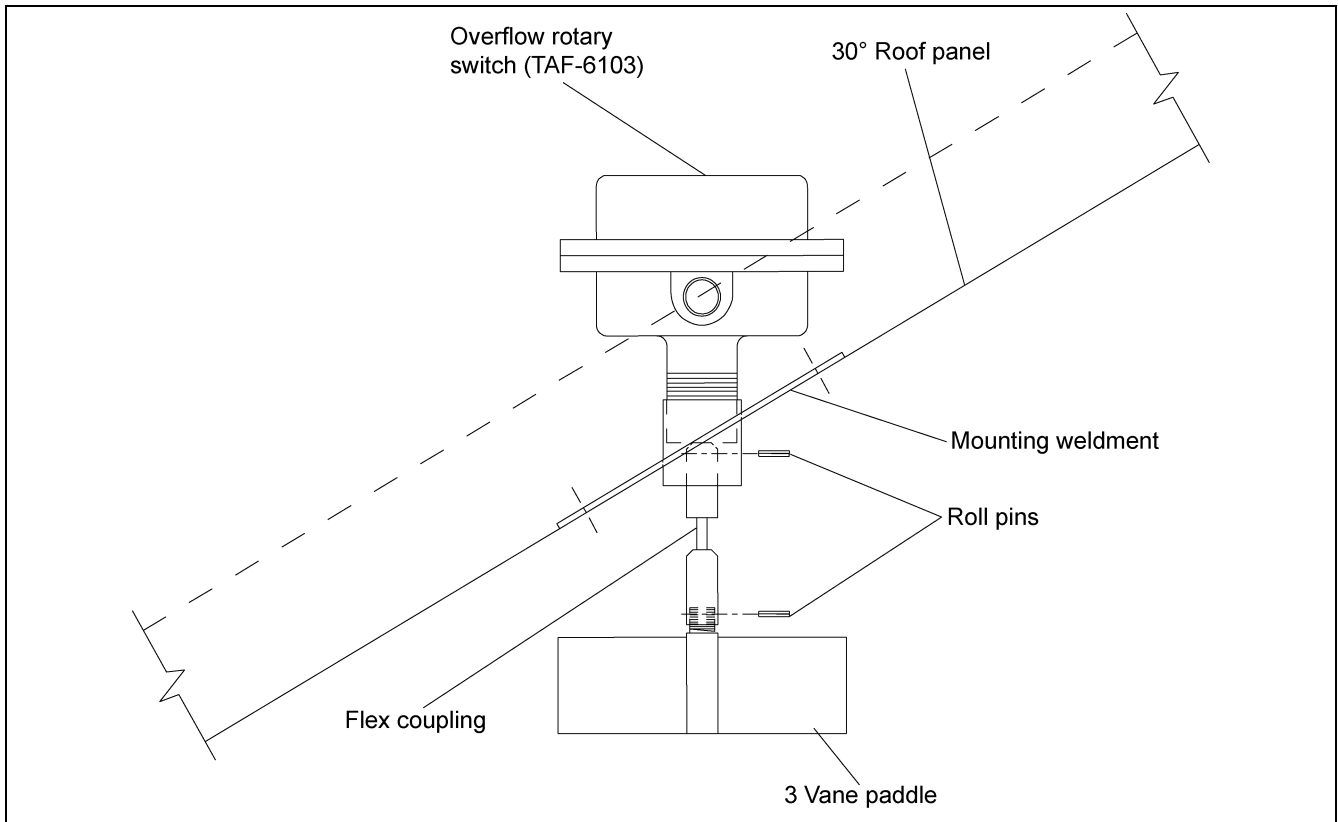


**Figure 3K** Drying Chamber Overflow Rotary Switch

### 3. Installation



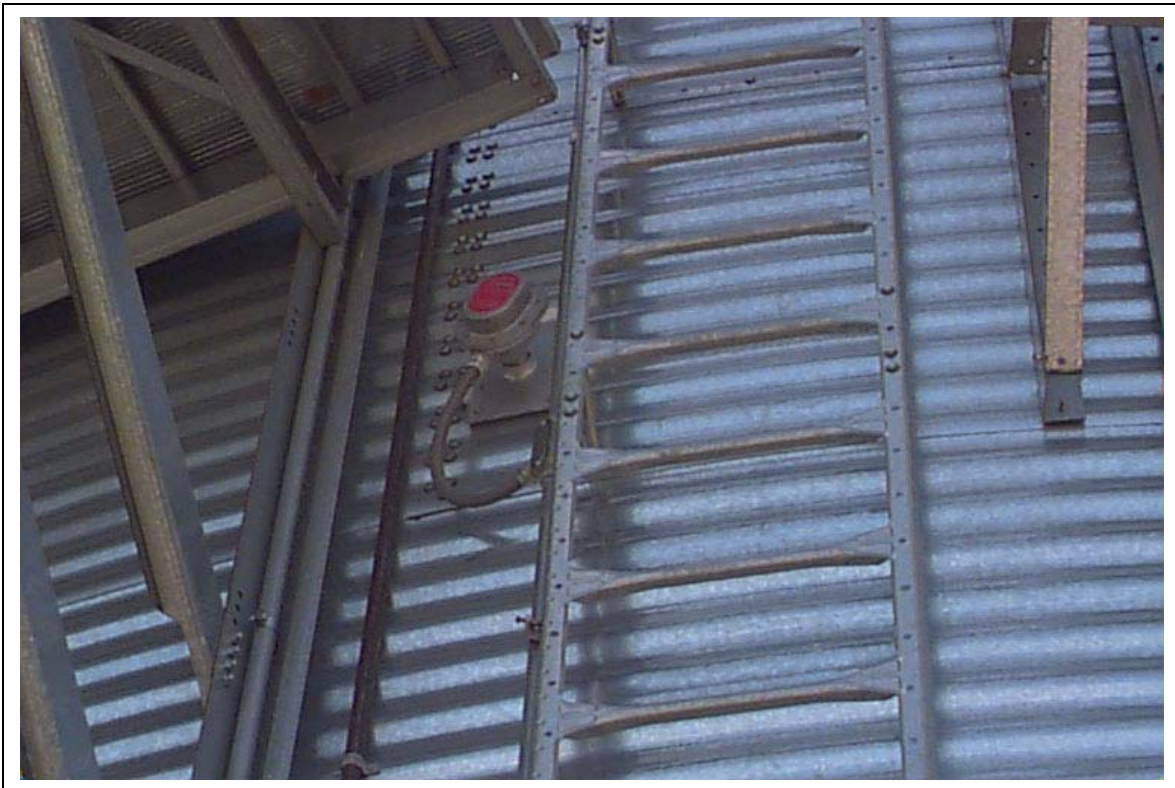
**Figure 3L** Drying Chamber Rotary Switch Placement



**Figure 3M** Drying Chamber Overflow Rotary Switch

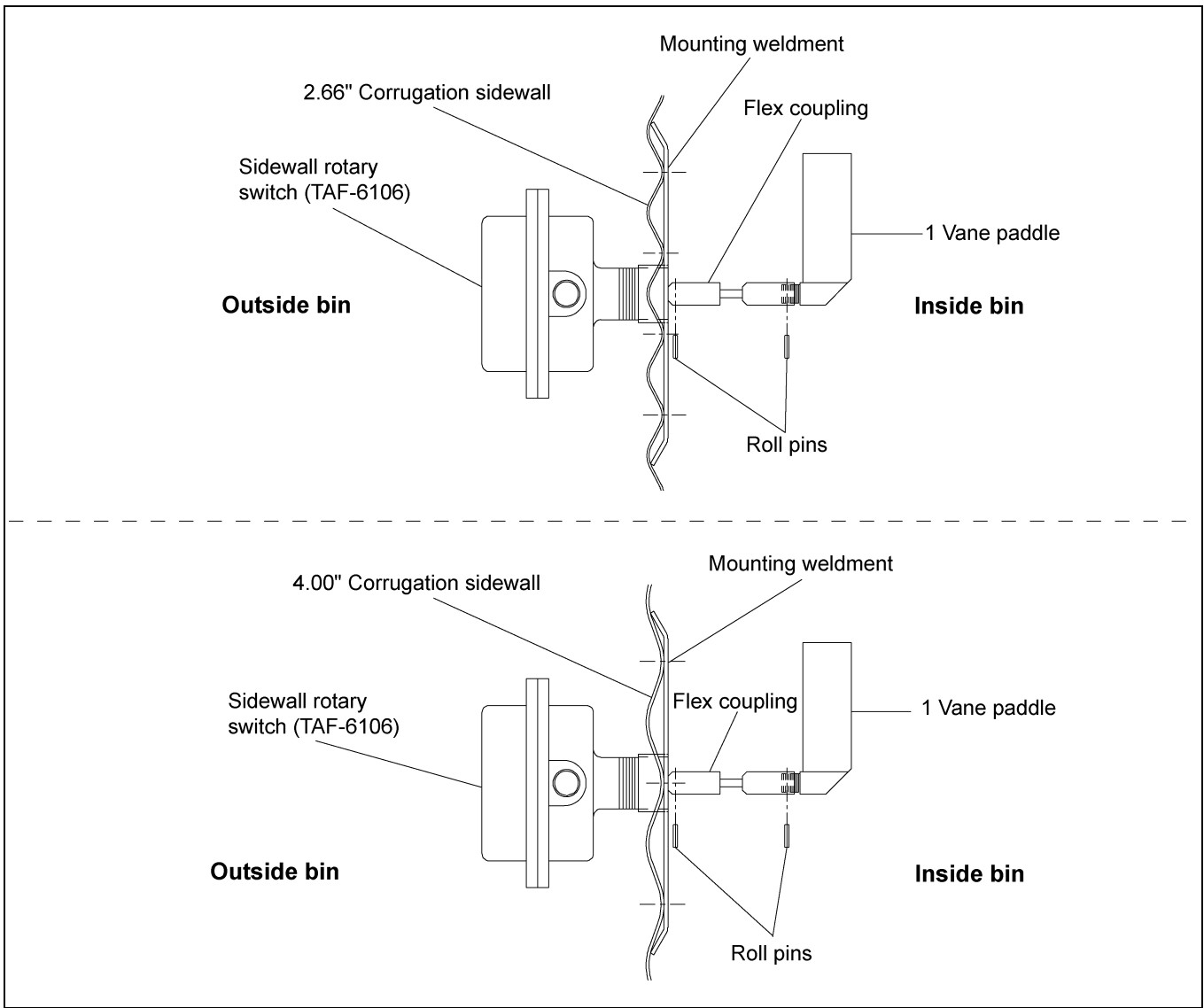
## Storage Chamber High-Limit Rotary Switch

1. Drill a 2" diameter hole through the sidewall 3' below the fan/heater.
2. If the bin is 2.66" corrugation the hole should be centered on an outside hill.
3. If the bin is 4.00" corrugation the hole should be centered on an outside valley.
4. Use the mounting plate as a pattern and drill four (4) 3/8" holes through the sidewall at the switch location so the plate can be bolted to the bin.
5. Add foam weather strip around the top and side of the mounting plate.
6. Caulk the underside of the mounting plate, on all sides of the 2" hole and where the plate meets the bin.
7. Bolt the mounting plate to the sidewall.
8. Attach the flex coupling to the rotary switch power pack using a roll pin.
9. Attach the 1 vane paddle to the flex coupling as shown *in Figure 3O on Page 22*.
10. Apply teflon tape or pipe sealant (not included) to the rotary switch power pack threads and thread the rotary switch power pack into the mounting plate coupling.
11. Make sure the conduit hole is facing down or is horizontal.



**Figure 3N** Storage Chamber Rotary Switch

### 3. Installation



**Figure 30** Storage Chamber High-Limit Rotary Switch

## Liquid Propane (LP)

Top Dry dryers have internal vaporizers and are designed to operate on liquid draw from the supply tank. Avoid using propane supply tanks that have been used for vapor draw for long periods of time. When using liquid draw systems, any moisture that may be present in tanks or lines may freeze when the system is used in cold weather. To avoid this situation, purge the system with methanol.

### NOTICE

**Do not use tanks which have previously been used for ammonia or fertilizer solutions. These substances are extremely corrosive and will damage fuel supply and burner parts.**

Because the vaporizer coil may need to be adjusted during operation flexible hose suitable for LPs should be used for the final field connection.

See the [below](#) "Fuel Systems and Recommendations Chart" for liquid propane (LP) to determine the correct size line to run from the tank to the dryer. Have a qualified gas service person inspect the installation to be sure that everything is installed according to local codes and ordinances.

After installation is complete, check all connections for leaks with liquid detergent or comparable. Wear rubber gloves and eye protection. Avoid contact with liquid propane.



**Do not use flame for leak testing.**

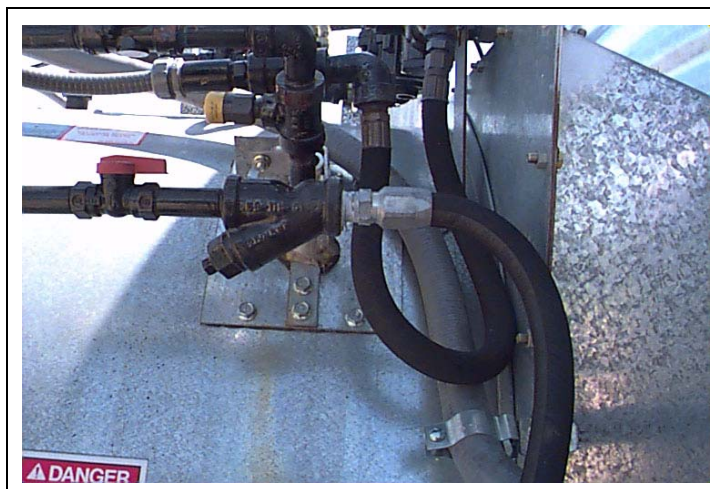


Figure 3P LP Line Field Connection

### Fuel System Specifications and Recommendations Liquid Propane (LP)

Dryer Fan Size	Dryer Horsepower	Maximum Heat Capacity BTU per Hour	Maximum Fuel Flow Gallons per Hour	Minimum Line Size	Orifice Size	Minimum Operating Pressure	Maximum Operating Pressure
28"	10-12	3 Million	32	1/2"	1/4"	1 lb.	15 lbs.
36"	15	5 Million	54	1/2"	21/64"	1 lb.	15 lbs.
40"	15	5.5 Million	60	1/2"	11/32"	1 lb.	15 lbs.
42"	30	9 Million	95	1/2"	0.328"	1 lb.	15 lbs.
42"	40	9.5 Million	104	3/4"	29/64"	1 lb.	15 lbs.

### 3. Installation

## Natural Gas (NG)

This dryer is designed to operate on natural gas. Natural gas units have a larger orifice to accommodate lower pressures sometimes found with natural gas and do not have vaporizer coils like liquid propane units. A regulated pressure of 10 PSI minimum, 30 PSI maximum must be provided at the field connection point on the fan/heater unit, with gas available in sufficient volume to maintain the operating pressure.

See the *below* "Fuel Systems and Recommendations Chart" for natural gas (NG) to determine the correct size line to run to the dryer. Have a qualified gas service person inspect the installation to be sure everything is installed according to local codes and ordinances.

After installation is complete, check all connections for leaks with liquid detergent or comparable. Wear rubber gloves and eye protection.



**Do not use flame for leak testing.**

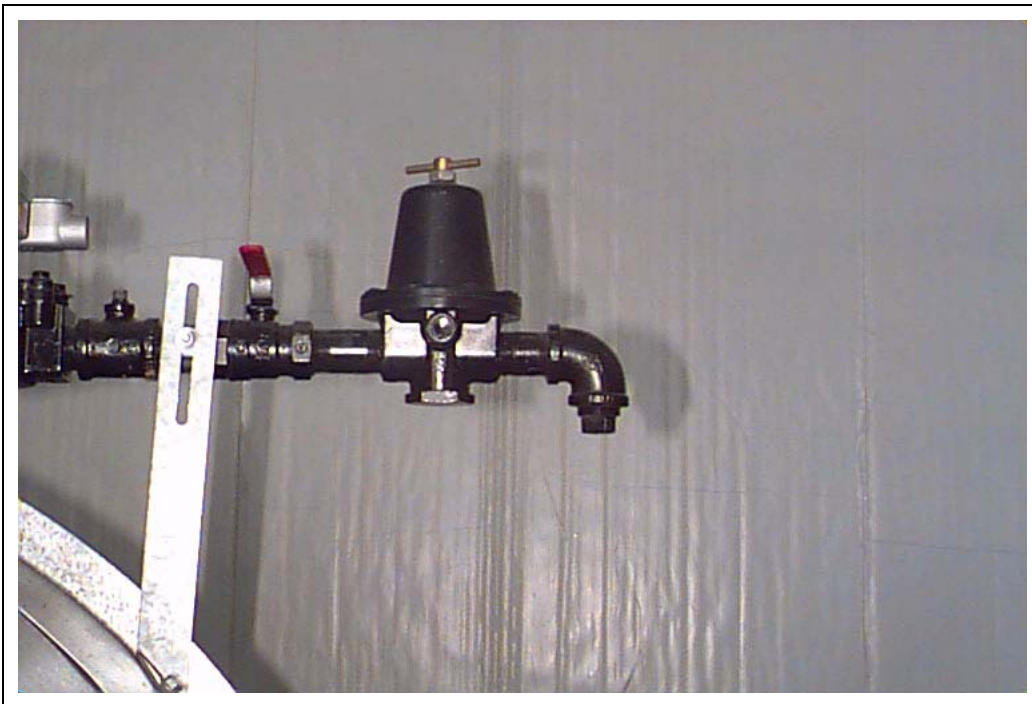


Figure 3Q NG Line Field Connection

### Fuel System Specifications and Recommendations Natural Gas (NG)

Dryer Fan Size	Dryer Horsepower	Maximum Heat Capacity BTU per Hour	Maximum Fuel Flow Cubic Ft. per Hour	Minimum Line Size	Orifice Size	Minimum Operating Pressure	Maximum Operating Pressure
28"	10-12	3 Million	2970	1-1/2"	3/8"	1 lb.	7 lbs.
36"	15	5 Million	5280	2"	1/2"	1 lb.	7 lbs.
40"	15	5.5 Million	5965	2"	17/32"	1 lb.	7 lbs.
42"	30	9 Million	9536	2"	43/64"	1 lb.	7 lbs.
42"	40	9.5 Million	10445	2"	45/64"	1 lb.	7 lbs.



### Power Supply

An adequate power supply and proper wiring are important factors to achieve maximum performance and long life of the dryer. Electrical service must be adequate enough to prevent low voltage damage to motors and control circuits. (See electrical load information [on Page 29](#).)

### Transformer and Wiring Voltage Drop

It is necessary to know the distance from the unit to the available transformer and the horsepower of the fan unit. Advise the service representative of the local power supplier that an additional load will be placed on the line. Each fan motor should be wired through a fused or circuit breaker disconnect switch. Check on KVA rating of transformers, considering total horsepower load. The power supply wiring, main switch equipment and transformers must provide adequate motor starting and operating voltage. Voltage drop during motor starting should not exceed 14% of normal voltage and after motor is running at full speed it should be within 8% of normal voltage. Check electrical load information for HP ratings and maximum amp loads to properly size wire and fusing elements. Standard electrical safety practices and codes should be used. (Refer to National Electrical Code Standard Handbook by National Fire Protection Association.)

### Machine to Earth Grounding

It is very important that a *Machine to Earth Ground Rod* be installed at the fan. This is true even if there is a ground at the pole 15' away. Place the ground rod within 8' of the dryer and attach it to the dryer control panel with at least a #6 solid, bare, copper ground wire and the clamp provided. The grounding rod located at the power pole will not provide adequate grounding for the dryer. The proper grounding will provide additional safety in case of any short and will ensure long life of all circuit boards and the ignition system. The ground rod must be in accordance with local requirements.

## 4. Electrical Power Supply

### Proper Installation of Ground Rod

The ground rod should not be driven into dry ground.

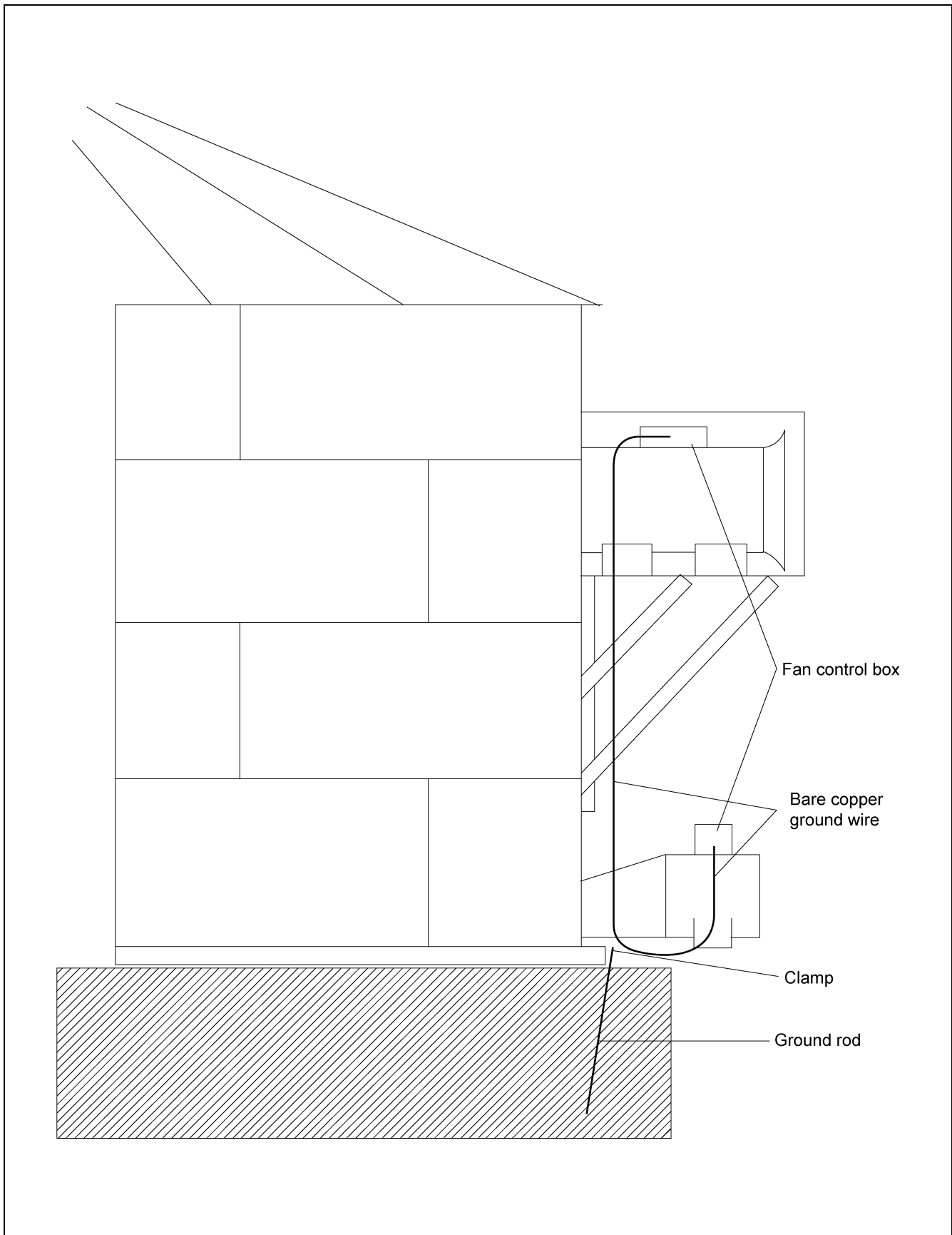
Follow these instructions for proper installation:

1. Dig a hole large enough to hold 1 to 2 gallons of water.
2. Fill hole with water.
3. Insert rod through water and jab it into the ground.
4. Continue jabbing the rod up and down. The water will work its way down the hole, making it possible to work the rod completely into the ground. This method of installing the rod gives a good conductive bond with the surrounding soil.
5. Connect the bare copper ground wire to the rod with the proper ground rod clamp. *(See Figure 4B on Page 27.)*
6. Connect the bare copper ground wire to the fan control boxes with a grounding lug.
7. Ground wire must not have any breaks or splices.



**Dig a hole large enough to hold 1 or 2 gallons of water. Work the ground rod into the earth until it is completely in the ground.**

Figure 4A



**Figure 4B** *The Top Dry and Ground Rod Attachment Illustration*

## 4. Electrical Power Supply

### Power/Motor Wiring

The *Figure 4C* details the configuration for correct main power installation. Use the diagram in conjunction with the electrical load information and wire size information provided. The diagram details the correct main power installation for 220V 1 PH, 230V 3 PH, 460V 3 PH, 575V 3 PH and 380V 3 PH 50 Hz power supplies.

On all 3 phase systems put the leg with the highest potential difference between that leg and ground (wild or high voltage leg) on the center terminal (L2) at the motor starter.

#### NOTICE

**Standard electrical safety procedures should be used. (Refer to the National Electrical Code Standard Handbook by the National Fire Protection Association.) A qualified electrician should make all electrical wiring installations. Follow all local or national electrical safety standards and ordinances when installing the equipment.**

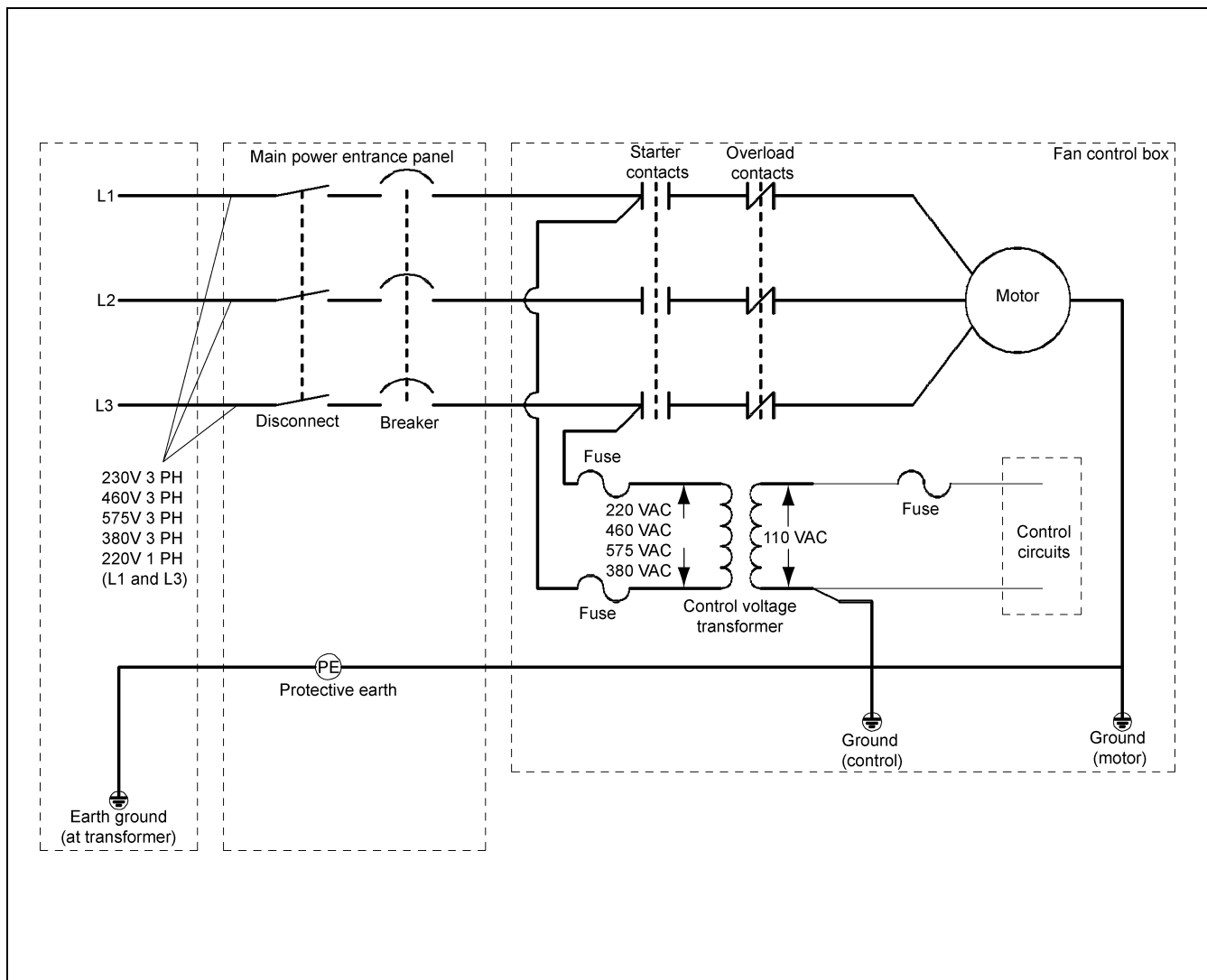


Figure 4C Main Power Schematic

## Electrical Load Information

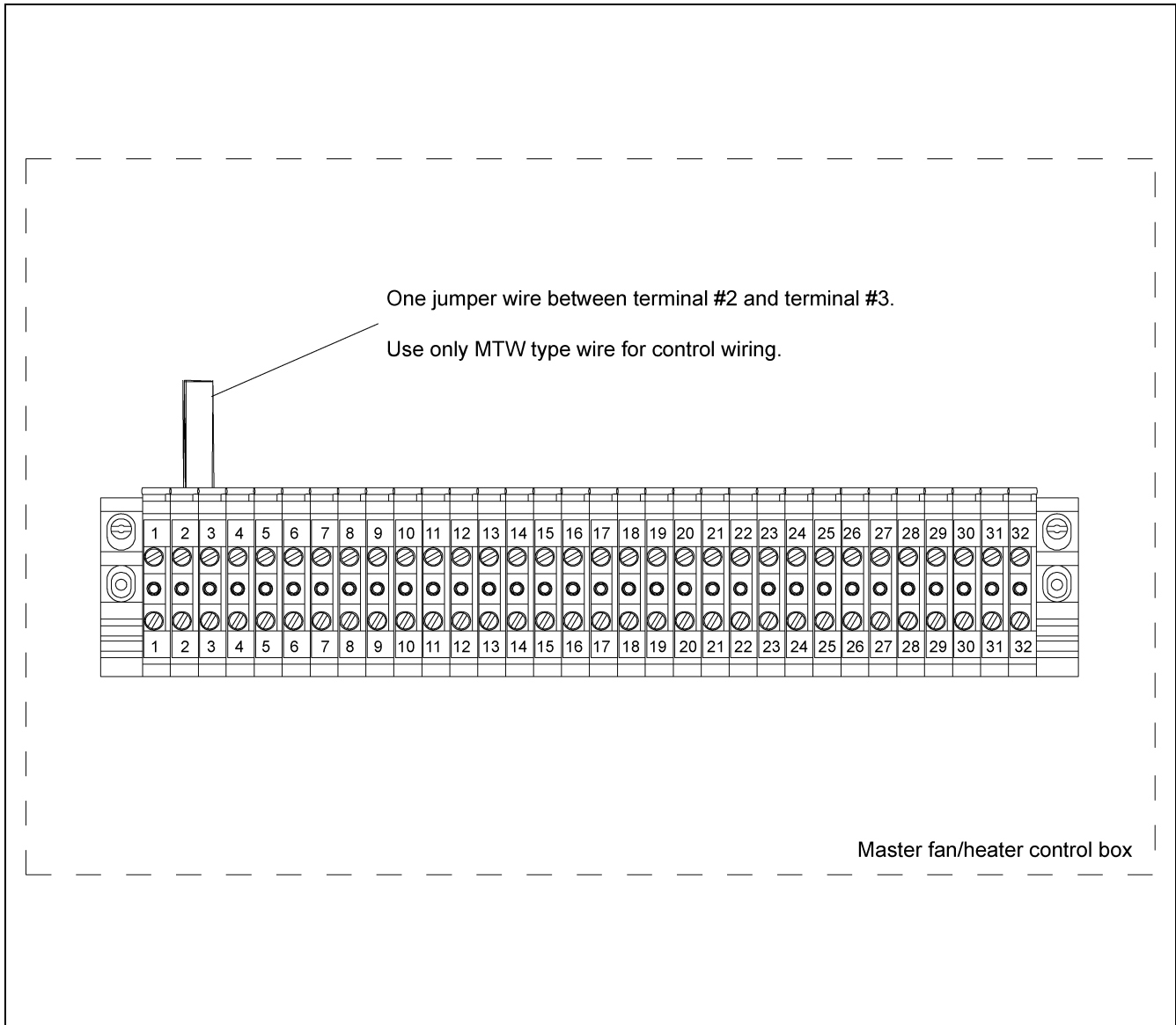
The [Chart below](#) provide information for the electrician wiring the grain dryer and are a reference guide for parts. It is recommended that you contact the local power company and have a representative survey the installation to see that the wiring is compatible with their system and that adequate power is supplied to the unit. **NOTE:** *The only thing connected to the recommended service amps should be the grain dryer. Standard electrical safety procedures should be used. (Refer to the National Electrical Code Standard Handbook by the National Fire Protection Association.) A qualified electrician should make all electrical wiring installations.*

Dryer Fan Size	Voltage	Horsepower	Full Load Amps	Fuse (Slow Blow)	Breaker
28"	220V 1 PH	10-12	48	100	100
	208V 3 PH	10-12	35	80	80
	220V 3 PH	10-12	33	80	80
	380V 50 Hz	10-12	15	40	40
	460V 3 PH	10-12	17	40	40
	575V 3 PH	10-12	15	40	40
36"	220V 1 PH	10-16	78	150	150
	208V 3 PH	15	44	125	125
	220V 3 PH	15	39	100	100
	380V 50 Hz	15	27	80	80
	460V 3 PH	15	20	50	50
	575V 3 PH	15	16	40	40
40"	220V 1 PH	10-16	78	150	150
	208V 3 PH	15	44	125	125
	220V 3 PH	15	39	100	100
	380V 50 Hz	15	27	80	80
	460V 3 PH	15	20	50	50
	575V 3 PH	15	16	40	40
42"	208V 3 PH	30	80	150	150
	220V 3 PH	30	74	150	150
	380V 50 Hz	30	39	100	100
	460V 3 PH	30	37	100	100
	575V 3 PH	30	30	80	80
42"	208V 3 PH	40	108	200	200
	220V 3 PH	40	102	200	200
	380V 50 Hz	40	47	100	100
	460V 3 PH	40	51	100	100
	575V 3 PH	40	40	100	100

### Stand Alone Fan/Heater

The Series 2000 Top Dry master fan/heater can operate as a stand alone fan/heater unit. If installed as a stand alone unit, no control center is used, all timers and temperatures are set at the fan/heater unit and the unit is stopped and started at the fan/heater. To wire the Series 2000 Fan/Heater unit as a stand alone unit do the following:

1. Place one jumper between terminal #2 and terminal #3 in the master fan/heater control box.
2. [Figure 4D](#) details the placement of the jumper.



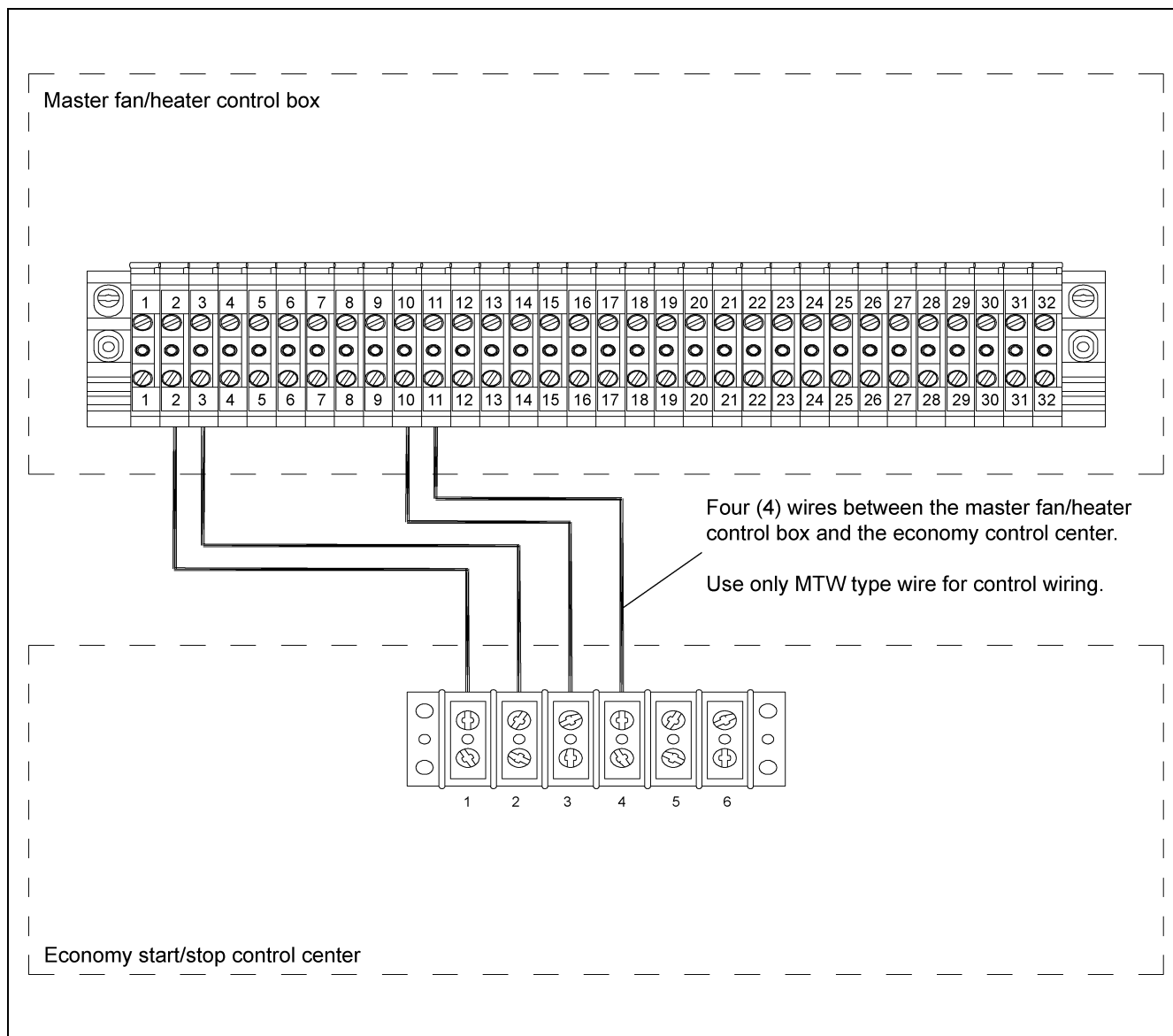
**Figure 4D** Wiring for a Stand Alone Fan/Heater Unit

## Economy Control Center Interconnect

The Series 2000 Top Dry economy control center allows the fan/heater unit(s) to be stopped and started at the economy control center. All timers and temperatures are set at the fan/heater unit(s). To wire the economy control center to the master fan/heater unit do the following:

**NOTE:** DO NOT use solid wire for interconnection.

1. Run four (4) 16 gauge MTW/THHN type wires from the economy control center to the master fan/heater unit.
2. Connect the wires as shown in [Figure 4E](#).



**Figure 4E** Wiring for the Economy Control Center to the Master Fan/Heater Unit

## 4. Electrical Power Supply

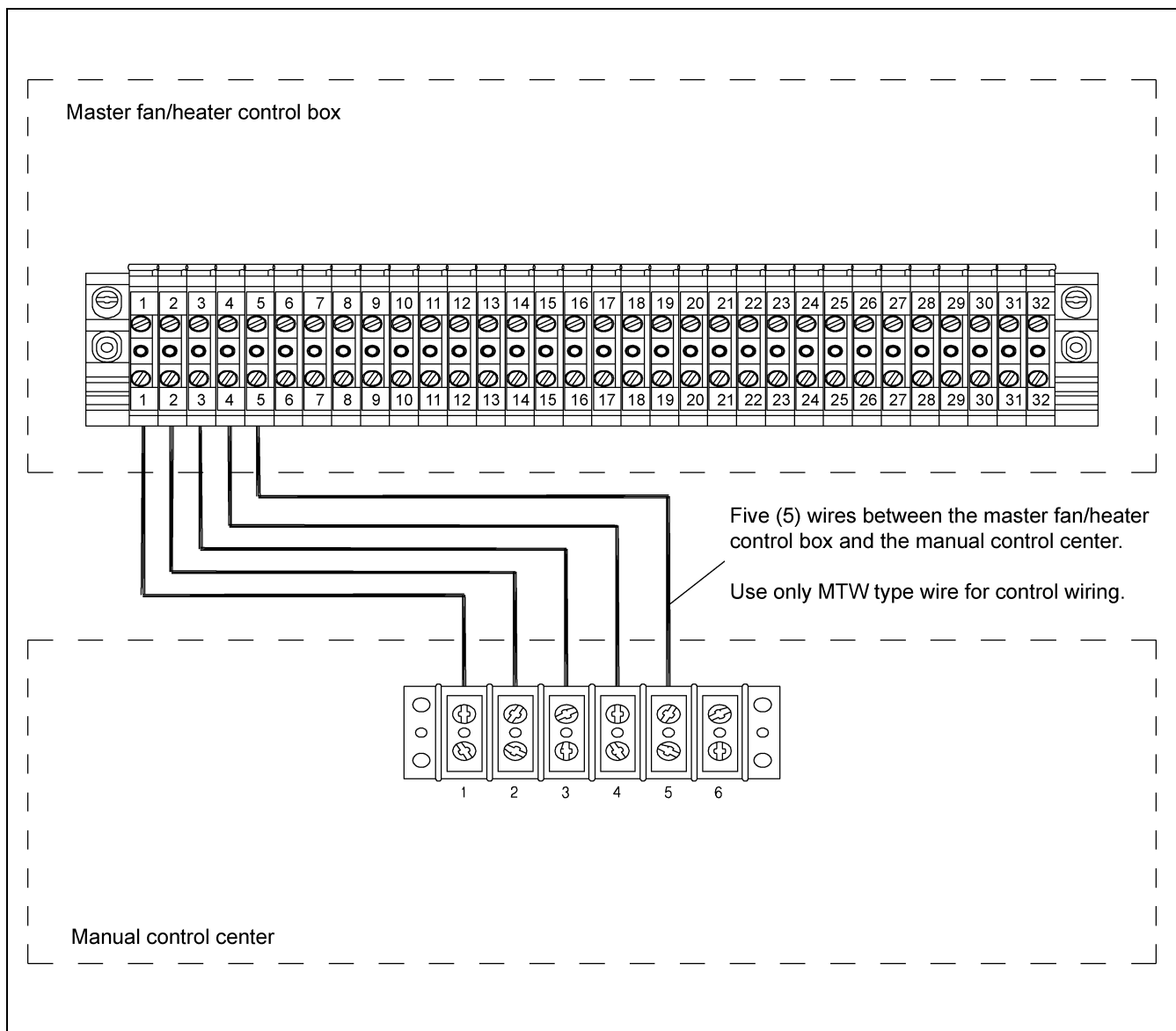
### Manual Control Center Interconnect

The Series 2000 Top Dry manual control center allows the fan/heater unit(s) to be stopped and started and all timers and temperatures to be set at the manual control center. To wire the manual control center to the master fan/heater unit do the following:

**NOTE:** *DO NOT use solid wire for interconnection.*

1. Run five (5) 16 gauge MTW/THHN type wires from the manual control center to the master fan/heater unit.
2. Connect the wires as shown in [Figure 4F](#).

**NOTE:** *A shielded 16 gauge cable is recommended for use on the network connection. The network wires for this configuration are attached to terminal #4 and terminal #5. Ground each end of the shielded cable to the housing. A shielded 16 gauge 2 wire cable can be purchased from GSI. Part #WR-16/2S.*



**Figure 4F** *Wiring for the Manual Control Center to the Master Fan/Heater Unit*



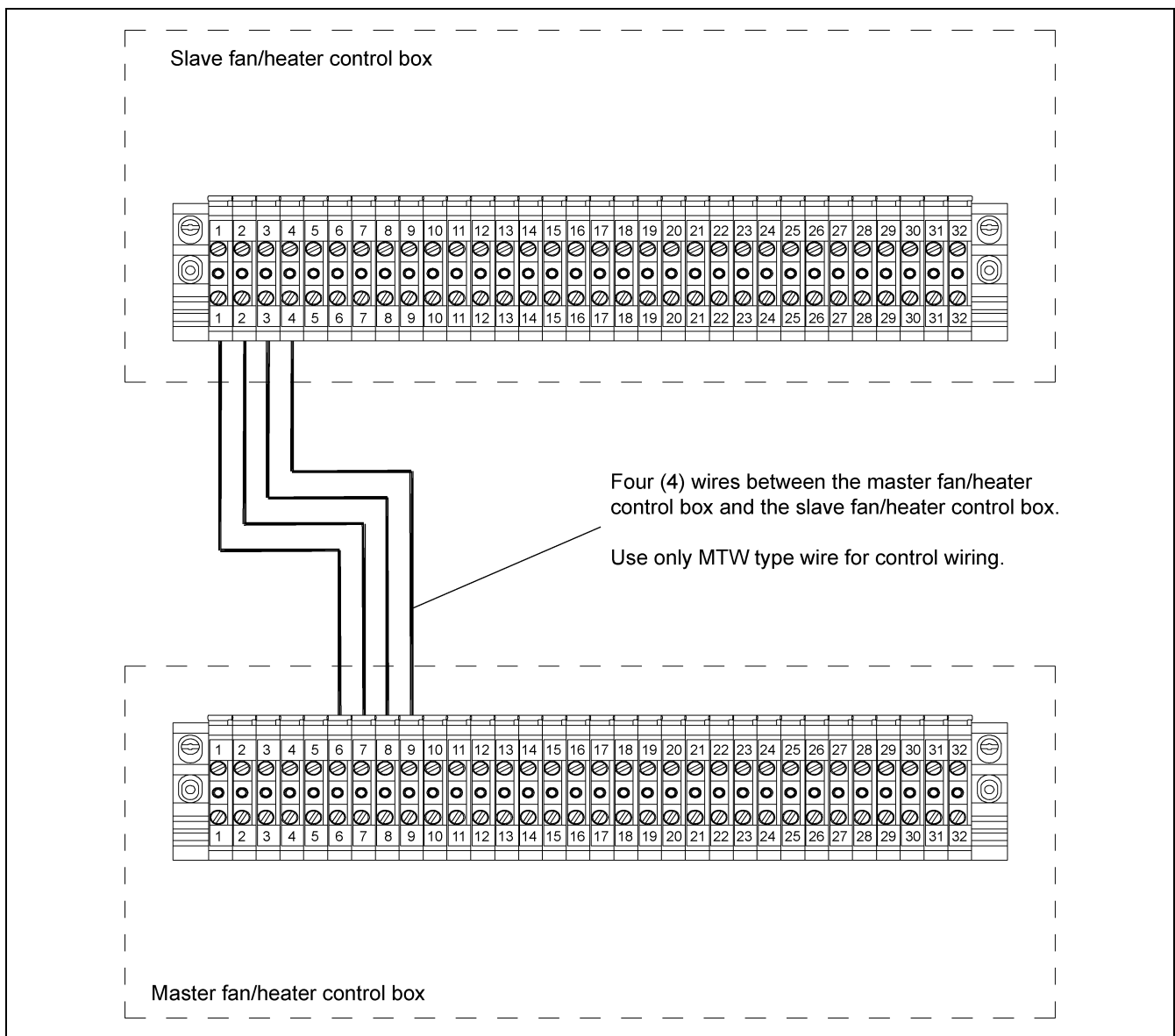
## Master to Slave Interconnect

A slave fan/heater unit can be added to operate in unison with the master fan/heater unit. The interconnect between the master and slave fan/heater units remains the same regardless of the type or presence of a control center. To wire a slave fan/heater unit to a master fan/heater unit do the following:

**NOTE:** *DO NOT use solid wire for interconnection.*

1. Run four (4) 16 gauge MTW/THHN type wires from the master fan/heater unit to the slave fan/heater unit.
2. Connect the wires as shown in [Figure 4G](#).

**NOTE:** *A shielded 16 gauge cable is recommended for use on the network connections. The network connections for this configuration are attached to terminal #8 and terminal #9 in the master unit and terminal #3 and terminal #4 in the slave unit. Ground each end of the shielded cable to the housing. A shielded 16 gauge 2 wire cable can be purchased from GSI. Part #WR-16/2S.*



**Figure 4G** *Wiring for a Slave Fan/heater Unit to a Master Fan/Heater Unit*

## 4. Electrical Power Supply

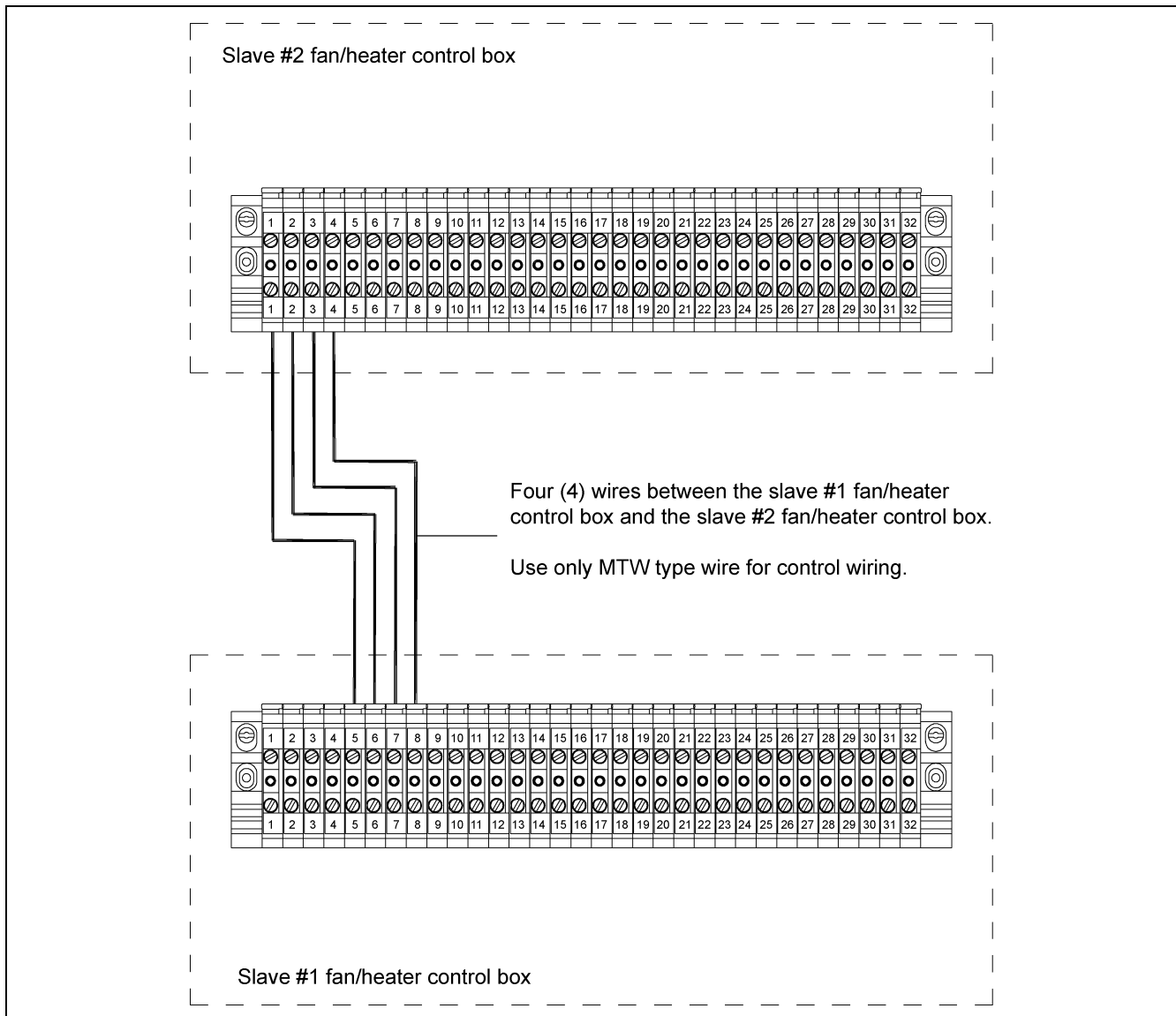
### Slave to Slave Interconnect

A second slave fan/heater unit can be added to operate in unison with the master fan/heater unit and another slave fan/heater unit. This would create a three (3) fan unit. The interconnect between the first slave fan/heater unit and the second slave fan/heater unit remains the same regardless of the type or presence of a control center. To wire a second slave fan/heater unit to another slave fan/heater unit do the following:

**NOTE:** *DO NOT* use solid wire for interconnection.

1. Run four (4) 16 gauge MTW/THHN type wires from the first slave fan/heater unit to the second slave fan/heater unit.
2. Connect the wires as shown in [Figure 4H](#).

**NOTE:** *A shielded 16 gauge cable is recommended for use on the network connections. The network connections for this configuration are attached to terminal #7 and terminal #8 in slave #1 and terminal #3 and terminal #4 in slave #2. Ground each end of the shielded cable to the housing. A shielded 16 gauge 2 wire cable can be purchased from GSI. Part #WR-16/2S.*

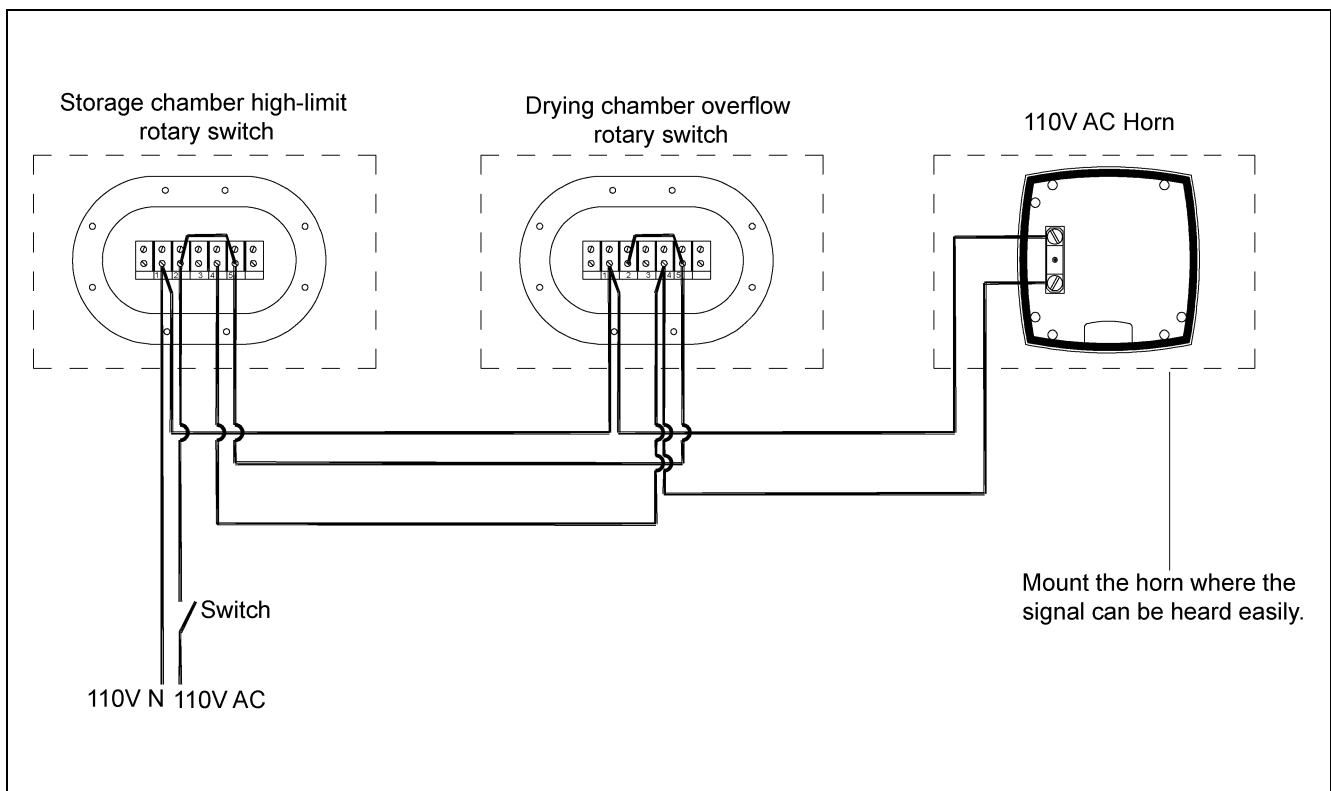


**Figure 4H** *Wiring for a Second Slave Fan/heater Unit to Another Slave Fan/Heater Unit*

## Rotary Switch and Horn Wiring

A drying chamber overflow rotary switch and a storage chamber high level rotary switch can be used to let the operator know when the drying chamber or the storage chamber is full. [Figure 4I](#) details one possible way of wiring both the drying chamber and the storage chamber rotary switches so that the horn will sound when either the drying chamber or the storage chamber is full. To wire the rotary switches and the horn do the following:

1. Run two (2) wires between an ON/OFF switch and the storage chamber rotary switch.
2. Run three (3) wires between the storage chamber rotary switch and the drying chamber rotary switch.
3. Run two (2) wires between the drying chamber switch and the horn.
4. Connect the wires as shown in [Figure 4I](#).



**Figure 4I** Wiring for the Rotary Switches and Horn

---

# NOTES

## GSI Group, LLC Limited Warranty

The GSI Group, LLC ("GSI") warrants products which it manufactures to be free of defects in materials and workmanship under normal usage and conditions for a period of 12 months after sale to the original end-user or if a foreign sale, 14 months from arrival at port of discharge, whichever is earlier. The end-user's sole remedy (and GSI's only obligation) is to repair or replace, at GSI's option and expense, products that in GSI's judgment, contain a material defect in materials or workmanship. Expenses incurred by or on behalf of the end-user without prior written authorization from the GSI Warranty Group shall be the sole responsibility of the end-user.

### Warranty Extensions:

The Limited Warranty period is extended for the following products:

	Product	Warranty Period	
<b>AP Fans and Flooring</b>	Performer Series Direct Drive Fan Motor	3 Years	* Warranty prorated from list price: 0 to 3 years - no cost to end-user 3 to 5 years - end-user pays 25% 5 to 7 years - end-user pays 50% 7 to 10 years - end-user pays 75%
	All Fiberglass Housings	Lifetime	
	All Fiberglass Propellers	Lifetime	
<b>Cumberland Feeding/Watering Systems</b>	Feeder System Pan Assemblies	5 Years **	** Warranty prorated from list price: 0 to 3 years - no cost to end-user 3 to 5 years - end-user pays 50%
	Feed Tubes (1-3/4" and 2.00")	10 Years *	
	Centerless Augers	10 Years *	
	Watering Nipples	10 Years *	
<b>Grain Systems</b>	Grain Bin Structural Design	5 Years	
<b>Grain Systems Farm Fans Zimmerman</b>	Portable and Tower Dryers	2 Years	† Motors, burner components and moving parts not included. Portable dryer screens included. Tower dryer screens not included.
	Portable and Tower Dryer Frames and Internal Infrastructure †	5 Years	

GSI further warrants that the portable and tower dryer frame and basket, excluding all auger and auger drive components, shall be free from defects in materials for a period of time beginning on the twelfth (12<sup>th</sup>) month from the date of purchase and continuing until the sixtieth (60<sup>th</sup>) month from the date of purchase (extended warranty period). During the extended warranty period, GSI will replace the frame or basket components that prove to be defective under normal conditions of use without charge, excluding the labor, transportation, and/or shipping costs incurred in the performance of this extended warranty.

### Conditions and Limitations:

THERE ARE NO WARRANTIES THAT EXTEND BEYOND THE LIMITED WARRANTY DESCRIPTION SET FORTH ABOVE. SPECIFICALLY, GSI MAKES NO FURTHER WARRANTY OF ANY KIND, EXPRESS OR IMPLIED, INCLUDING, WITHOUT LIMITATION, WARRANTIES OF MERCHANTABILITY OR FITNESS FOR A PARTICULAR PURPOSE OR USE IN CONNECTION WITH: (I) PRODUCT MANUFACTURED OR SOLD BY GSI OR (II) ANY ADVICE, INSTRUCTION, RECOMMENDATION OR SUGGESTION PROVIDED BY AN AGENT, REPRESENTATIVE OR EMPLOYEE OF GSI REGARDING OR RELATED TO THE CONFIGURATION, INSTALLATION, LAYOUT, SUITABILITY FOR A PARTICULAR PURPOSE, OR DESIGN OF SUCH PRODUCTS.

GSI shall not be liable for any direct, indirect, incidental or consequential damages, including, without limitation, loss of anticipated profits or benefits. The sole and exclusive remedy is set forth in the Limited Warranty, which shall not exceed the amount paid for the product purchased. This warranty is not transferable and applies only to the original end-user. GSI shall have no obligation or responsibility for any representations or warranties made by or on behalf of any dealer, agent or distributor.

GSI assumes no responsibility for claims resulting from construction defects or unauthorized modifications to products which it manufactured. Modifications to products not specifically delineated in the manual accompanying the equipment at initial sale will void the Limited Warranty.

This Limited Warranty shall not extend to products or parts which have been damaged by negligent use, misuse, alteration, accident or which have been improperly/inadequately maintained. This Limited Warranty extends solely to products manufactured by GSI.

Prior to installation, the end-user has the responsibility to comply with federal, state and local codes which apply to the location and installation of products manufactured or sold by GSI.

This equipment shall be installed in accordance with the current installation codes and applicable regulations which should be carefully followed in all cases. Authorities having jurisdiction should be consulted before installations are made.

G S I G R O U P



**GSI Group**  
**1004 E. Illinois St.**  
**Assumption, IL 62510-0020**  
**Phone: 1-217-226-4421**  
**Fax: 1-217-226-4420**  
**[www.gsiag.com](http://www.gsiag.com)**