

# 2003 Series 2000 Batch Fan/Heater and Control Installation Instructions

Installation  
Manual  
PNEG-634

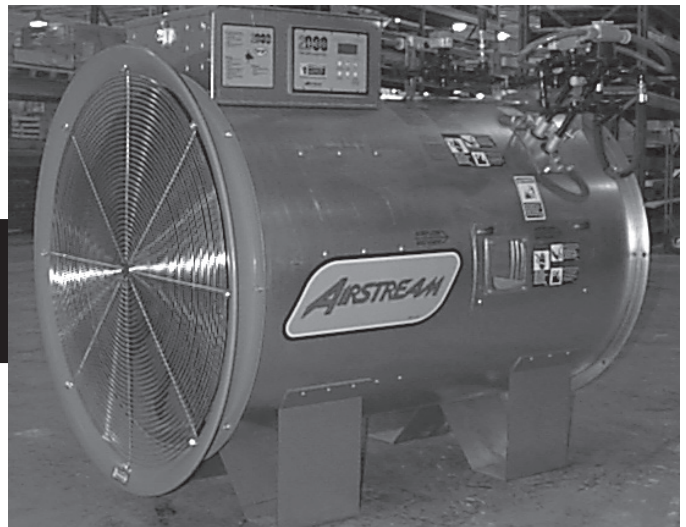

a division of  
THE GSI GROUP



PNEG-634

This equipment shall be installed in accordance iwth the current **INSTALLATION CODES FOR GAS BURNING APPLICANCES AND EQUIPMENT, CAN1\_B149.1 and B149.2**, or applicable provincial regulations which should be carefully followed in all cases. Authorities having jurisdiction shuld be consulted before installations are made.

Roof Warning, Operation & Safety.....4  
Safety Alert Decals.....5  
Safety Precautions:.....6  
Safety Sign-off Sheet:.....7  
Fan/Heater and Control Box Mounting.....8  
Control Box Bolt Patter.....9  
Grain Temperature Sensor Installation.....10  
Figure 2: Illustration of Grain Temperature Sensor.....11  
Figure 3: Grain Temperature Sensor Wiring.....12  
Multi-Grain Temperature Sensor Wiring.....13  
Plenum Temperature Sensor Installation.....14  
Airs witch Installation.....15  
Drying Chamber Overflow Switch Installation.....17  
Figure 6: Drying Chamber Overflow Switch.....18  
Storage Chamber Overflow Switch Installation.....19  
LP Fuel Specifications and Recommendations.....20  
NG Fuel Specifications and Recommendations.....21  
Electrical Power Supply.....22  
Figure 8: Ground Rod.....23  
Power/Motor Wiring.....24  
Main Power Schematic.....24  
Electrical Load Information.....25  
Wire Size Information.....26  
Stand Alone Heater Wiring.....27  
Economy Control Center to Heater Wiring.....28  
Manual Control Center to Heater Wiring.....29  
Master Heater to Slave Heater Wiring.....30  
Slave Heater to Slave Heater Wiring.....31  
Rotary Switch and Horn Wiring.....32  
Warranty.....33

## Roof Damage Warning and Disclaimer



GSI DOES NOT WARRANT ANY ROOF DAMAGE CAUSED BY EXCESSIVE VACUUM OR INTERNAL PRESSURE FROM FANS OR OTHER AIR MOVING SYSTEMS. ADEQUATE VENTILATION AND/OR "MAKEUP AIR" DEVICES SHOULD BE PROVIDED FOR ALL POWERED AIR HANDLING SYSTEMS. GSI DOES NOT RECOMMEND THE USE OF DOWNWARD FLOW SYSTEMS (SUCTION). SEVERE ROOF DAMAGE CAN RESULT FROM ANY BLOCKAGE OF AIR PASSAGES. RUNNING FANS DURING HIGH HUMIDITY/COLD WEATHER CONDITIONS CAN CAUSE AIR EXHAUST OR INTAKE PORTS TO FREEZE.

## Fan/Heater Installation & Operating Instructions

Thank you for choosing a Top Dry Series 2000 Fan and Heater unit. It is designed to give excellent performance and service for many years.

This manual describes the installation for all standard production Top Dry Series 2000 single fan, multi-fan and 2000 Series Heater Control units. Different models are available for liquid propane or natural gas fuel supply, with either single phase 230 volt, or three phase 208, 220, 380, 460 or 575 volt electrical power.

The principal concern of the GSI Group, Inc. ("GSI") is your safety and the safety of others asso-

ciated with grain handling equipment. This manual is written to help you understand safe operating procedures, and some of the problems that may be encountered by the operator or other personnel.

As owner and/or operator, it is your responsibility to know what requirements, hazards and precautions exist, and to inform all personnel associated with the equipment, or who are in the fan area. Avoid any alterations to the equipment. Such alterations may produce a very dangerous situation, where serious injury or death may occur.

## Safety Alert Symbol

The symbol shown is used to call your attention to instructions concerning your personal safety. Watch for this symbol; it points out important safety precautions. It means "ATTENTION", "WARNING", "CAUTION", and "DANGER". Read the message and be cautious to the possibility of personal injury or death.



### **WARNING! BE ALERT!**

Personnel operating or working around electric fans should read this manual. This manual must be delivered with the equipment to its owner. Failure to read this manual and its safety instructions is a misuse of the equipment.

Grain Systems, Inc. recommends contacting your local power company, and having a representative survey your installation so the wiring is compatible with their system, and adequate power is supplied to your unit.

Safety decals should be read and understood by all people in the grain handling area. The rotating blade, fire warning decals and voltage danger decal must be displayed on the fan can. The bottom right decal should be present on the inside bin door cover of the two ring door, 24" porthole door cover and the roof manway cover.

If a decal is damaged or is missing contact:

Grain Systems, Inc.  
1004 E. Illinois St.  
Assumption, IL 62510  
217-226-4421

A free replacement will be sent to you.

**⚠ DANGER!**



**High voltage.  
Will cause serious injury or death.  
Lockout power before servicing.**

DC-1224



**⚠ WARNING**

**Stay clear of rotating blade. Blade could start automatically. Can cause serious injury. Disconnect power before servicing.**

DC-1225





**⚠ WARNING**

**Flame and pressure beyond door. Do not operate with service door removed. Keep head and hands clear. Can cause serious injury.**

DC-1227

**⚠ DANGER**

 <p style="font-size: x-small;">Rotating flighting can kill or dismember.</p>	 <p style="font-size: x-small;">Flowing material can trap and suffocate.</p>	 <p style="font-size: x-small;">Crusted material can collapse and suffocate.</p>
--	--	---

Keep clear of all augers.  
DO NOT ENTER this bin!

If you must enter this bin:

1. Shut off and lock out all power.
2. Use safety harness and safety line.
3. Station another person outside the bin.
4. Avoid the center of the bin.
5. Wear proper breathing equipment or respirator.

Failure to heed these warnings will result in serious injury or death.

DC-552

**READ THESE INSTRUCTIONS  
BEFORE OPERATION AND SERVICE  
SAVE FOR FUTURE REFERENCE**

**Use Caution in the  
Operation of this  
Equipment**

1. Read and understand the operating manual before trying to operate the dryer.
2. Power supply should be OFF for service of electrical components. Use CAUTION in checking voltage or other procedures requiring power to be ON.
3. Check for gas leaks at all gas pipe connections. If any leaks are detected, do not operate the dryer. Shut down and repair before further operation.
4. Never attempt to operate the dryer by jumping or otherwise bypassing any safety devices on the unit.
5. Set pressure regulator to avoid excessive gas pressure applied to burner during ignition and when burner is in operation. Do not exceed maximum recommended drying temperature.
6. Keep the dryer clean. Do not allow fine material to accumulate in the plenum or drying chamber.
7. Use CAUTION in working around high speed fans, gas burners, augers and auxiliary conveyors which START AUTOMATICALLY.
8. Do not operate in any area where combustible material will be drawn into the fan.
9. Before attempting to remove and reinstall any propellor, make certain to read the recommended procedure listed within the servicing section of the manual.
10. Clean grain is easier to dry. Fine material increases resistance to airflow and requires removal of extra moisture.

The design and manufacture of this dryer is directed toward operator safety. However, the very nature of a grain dryer having a gas burner, high voltage electrical equipment and high speed rotating parts, does present a hazard to personnel, which can not be completely safeguarded against, without interfering with efficient operation and reasonable access to components.

Use extreme caution in working around high speed fans, gas-fired heaters, augers and auxiliary conveyors, which may start without warning when the dryer is operating on automatic control.

---

**KEEP THE DRYER CLEAN  
DO NOT ALLOW FINE  
MATERIAL TO ACCUMULATE  
IN THE PLENUM CHAMBER  
OR SURROUNDING THE  
OUTSIDE OF THE DRYER**

---

Continued safe, dependable operation of automatic equipment depends, to a great degree, upon the owner. For a safe and dependable drying system, follow the recommendations within this manual, and make it a practice to regularly inspect the operation of the unit for any developing problems or unsafe conditions.

Take special note of the safety precautions listed above before attempting to operate the dryer.

**This product is intended for the use of grain handling only. Any other use is considered a misuse of the product.**

**Some edges of the product components can be sharp. It is recommended that each component of this product be examined to determine if there are any safety considerations to be taken. Any and all necessary personal protective equipment should be worn at all times when handling, assembling, installing and operation of the product and/or components.**

**Guards are removed for illustration purpose only. All guards must be in place before/during operation.**

**Fan and Heater Mounting**

1. Inspect the fan platform for proper installation per instructions in the Top Dry erection manual.
2. Raise the Top Dry fan and heater units to the platform. Use the table below to determine the height of the platform from the base of the Top Dry unit.
3. Mount the Top Dry fan and heater units to the bin entrance sheets. Fan legs should set on the platform.

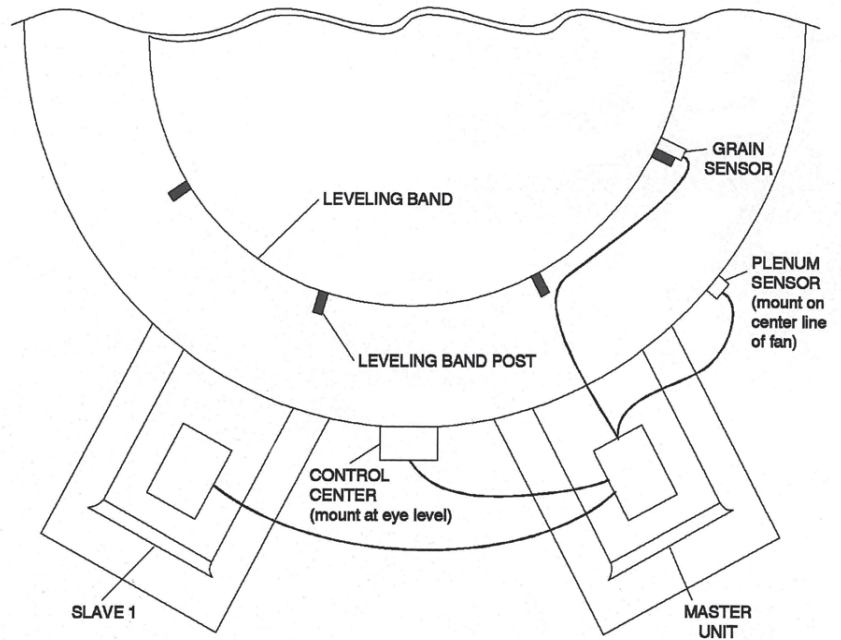

Two fan Top Dry configuration.

**Top Dry Bin Eave Height**

Number of Rings	Eave Height
5	18'-5"
6	22'-1"
7	25'-9"
8	29'-5"
9	33'-1"
10	36'-9"
11	40'-5"

**Control Box Mounting**

1. Control boxes, either the manual control center or econo control center, should be mounted at eye level. Make sure to have the control boxes mounted so that the fan and heater unit(s) are in view.

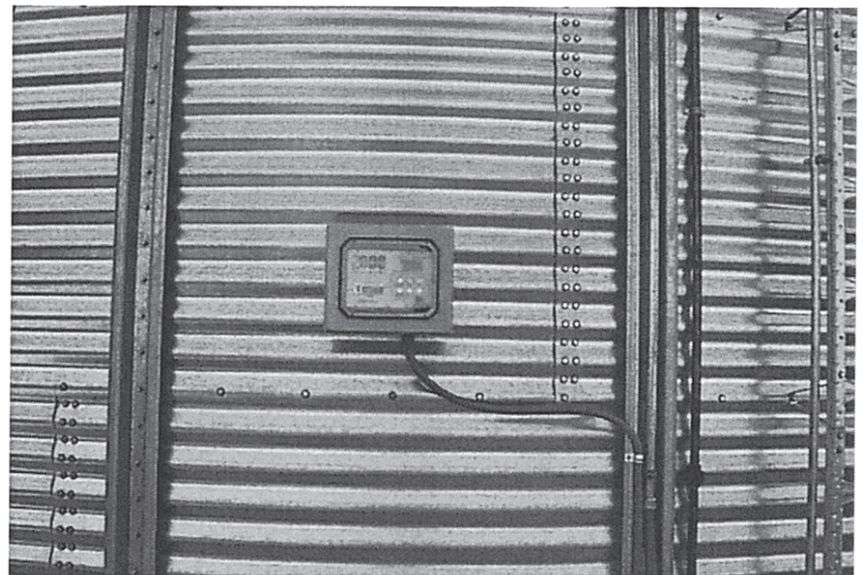

Control box mounted on bin.

2. Keep in mind that wire will be used to interconnect the control center with the fan and heater unit(s).
3. Use the hole pattern in Figure 1 to drill holes for mounting the control box.

**Manual Control Center Series 2000 Bolt Pattern**

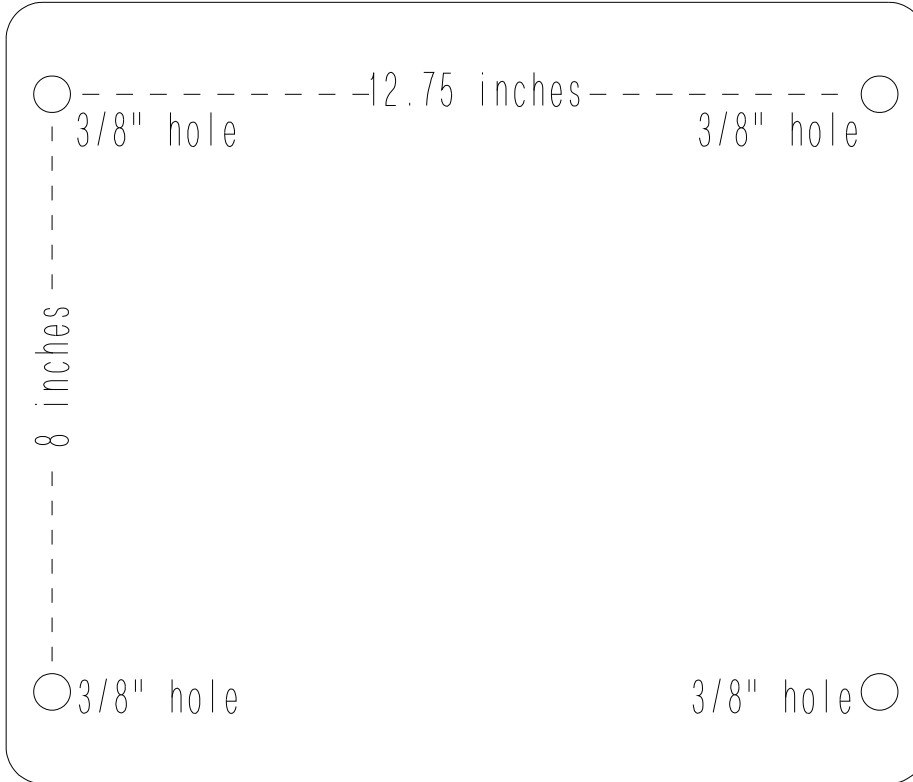

**Econo Start Series 2000 Bolt Pattern**

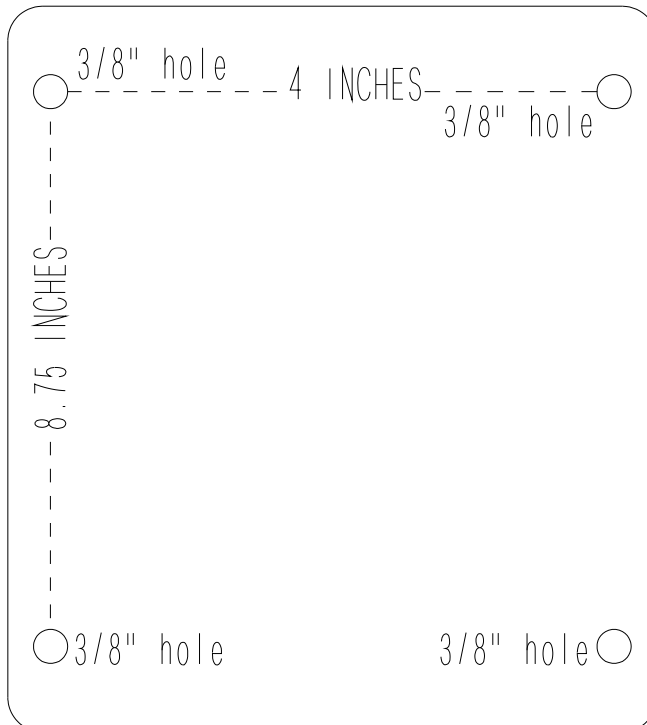

**Figure 1: Illustration of the bolt pattern for the manual and econo control center.**



### Grain Temperature Sensor Installation

1. Remove the two wires attached to the grain temperature sensor connected to terminal #22 and terminal #23 in the fan control box.
2. Mount the grain temperature sensor bracket on an outside leveling band post (figure 2).
3. With bin bolts mount the bracket so that the sensor is 17.1/2" above the floor sheet rib.
4. Wire tie the cord so that it feeds up the leveling band post, and across the top leveling band.
5. Take the cord through the space between the roof and the top sidewall sheet.
6. Run the cord back into the fan control box.
7. Install the two wires from the cord into terminal #22 and terminal #23 (figure 3).



**Grain temperature sensor bracket mounted on leveling band post.**

Grain Temperature Sensor Installation

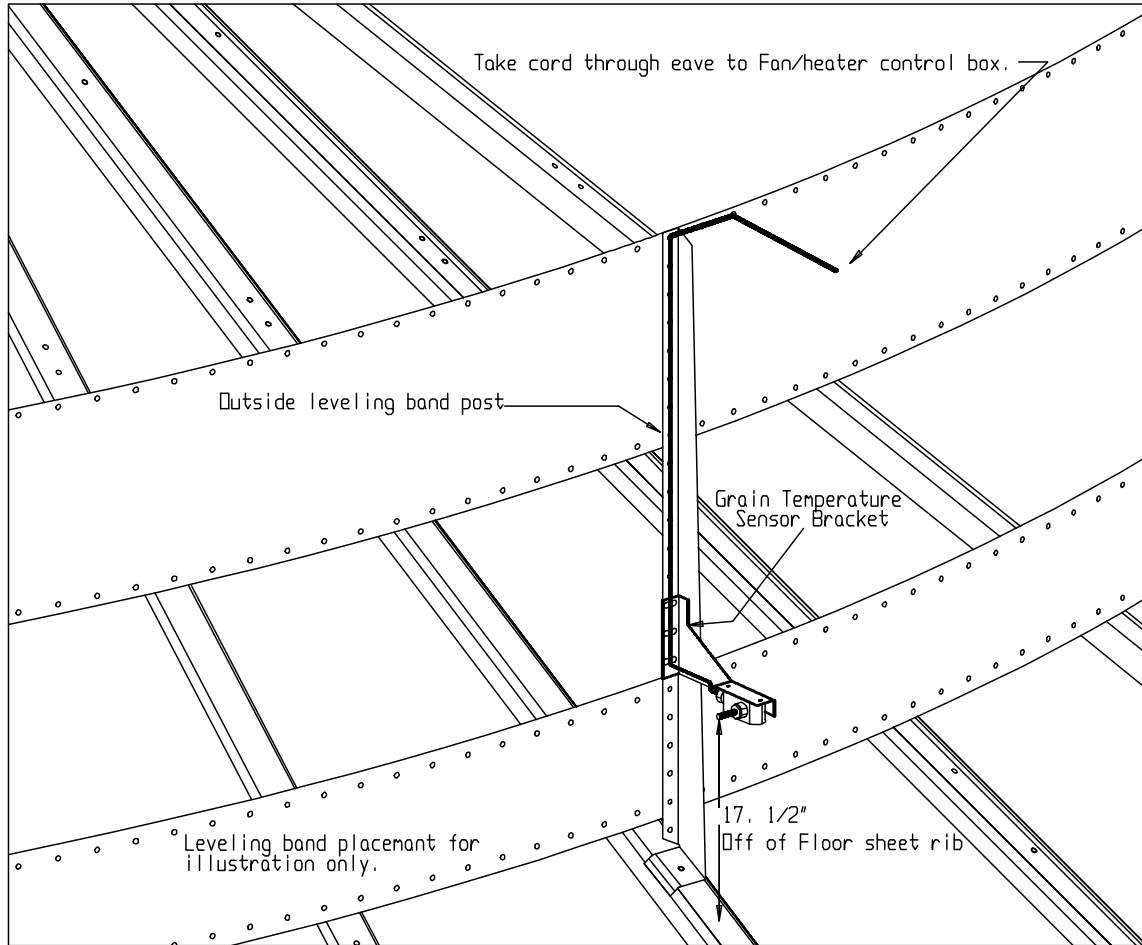
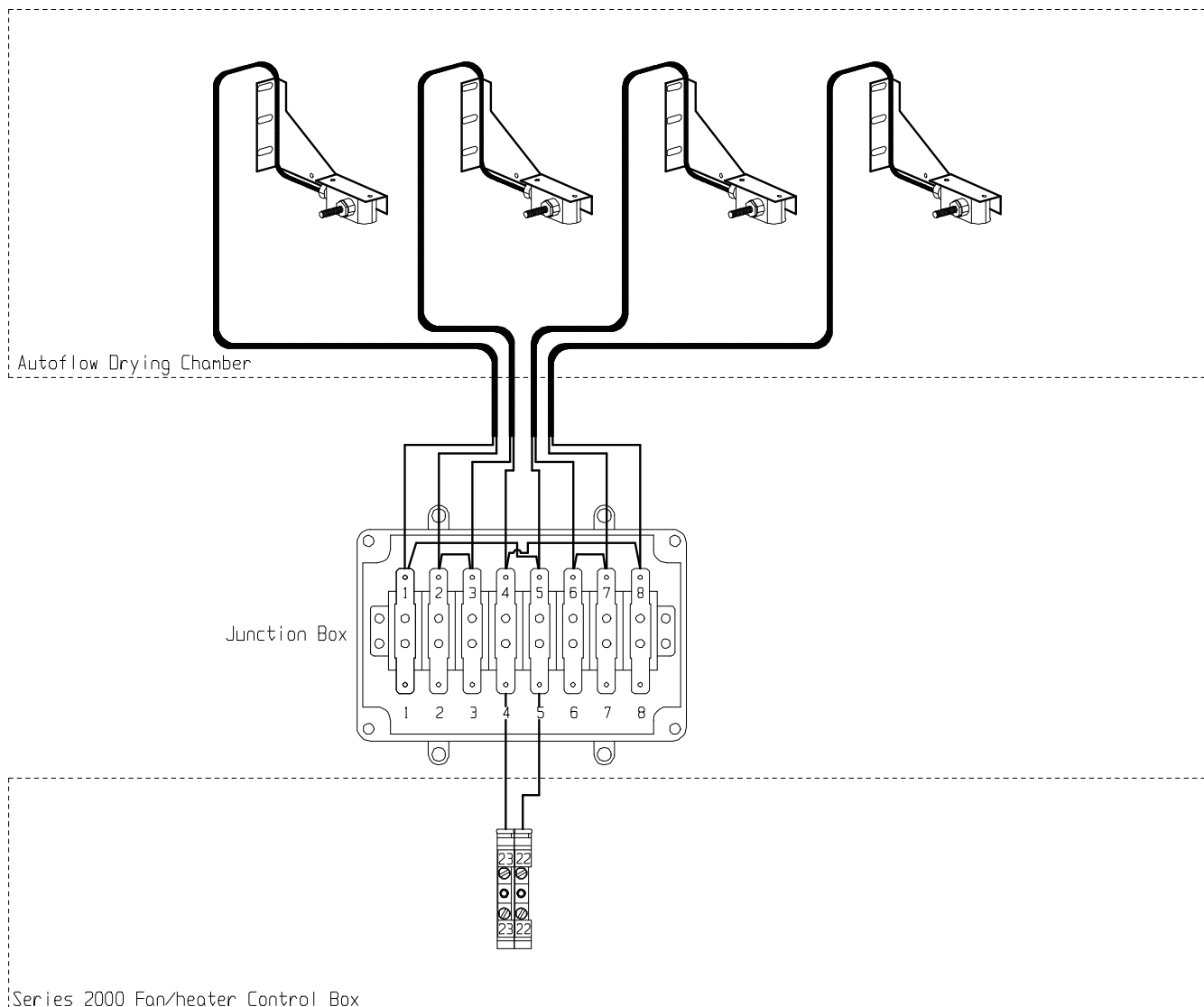

Figure 2: Illustration of grain temperature sensor mounted on outside leveling band post.



## Multi-Grain Temperature Sensor

1. Remove the two wires attached to the grain temperature sensor connected to terminal #22 and terminal #23 in the fan control box.
2. Mount the four grain temperature sensor brackets evenly around the drying chamber on outside leveling band posts (figure 2).
3. With bin bolts mount the bracket so the sensor is 17.1/2" above the floor sheet rib.
4. Wire tie the cords so they feed up the leveling band post, and across the top leveling band.
5. Take the cords through the space between the roof and the top sidewall sheet. There should be enough on all temperature sensor brackets to exit the drying chamber at the same place.
6. Run the cords into the junction box after the junction box has been mounted to the bin.
7. Wire the four temperature sensors Figure 4.



**Figure 4: Illustration of the connection between the master heater control box and multiple sensors in the drying chamber.**

PLENUM HI LIMIT INSTALLATION

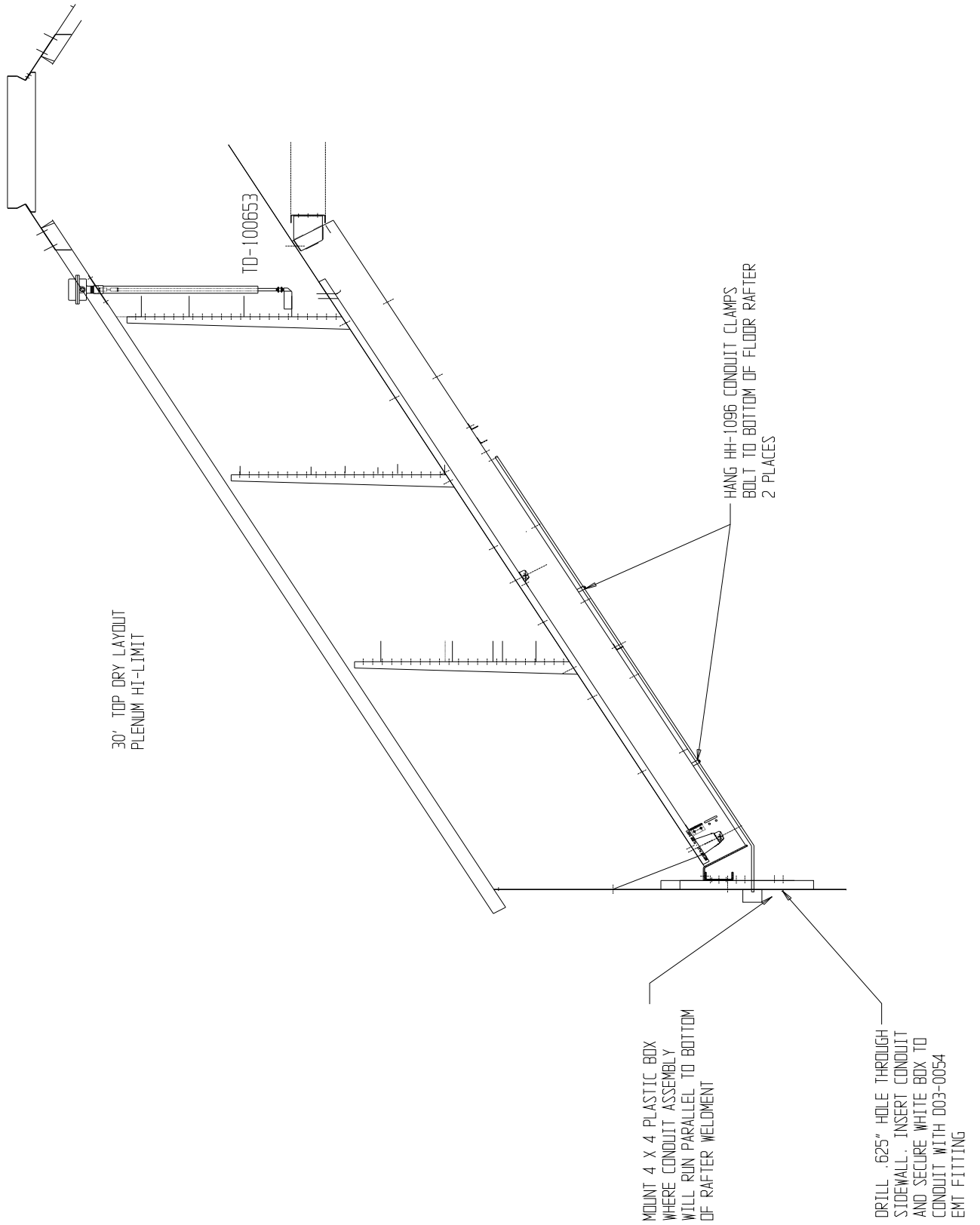

TOP DRY PLENUM HI LIMIT INSTALLATION

1. Assemble two pieces of conduit together with coupler.
2. Mount conduit clamps to conduit assembly.
3. Locate conduit assembly on the bottom of a rafter at least 2 feet to one side of the fan entrance. Do not install between two fan entrances.
4. Mark bin wall where conduit will pass through and drill a hole just large enough to allow the conduit to pass through. Seal this with caulking when complete.
5. Install white PVC box assembly on outside of bin wall.
6. Insert 10' capillary into conduit assembly.
7. Connect SJO cord to hi limit and connect wires to terminals 20 and 21 on the master fan terminal strip. These terminals are J7-08, and J7-03.

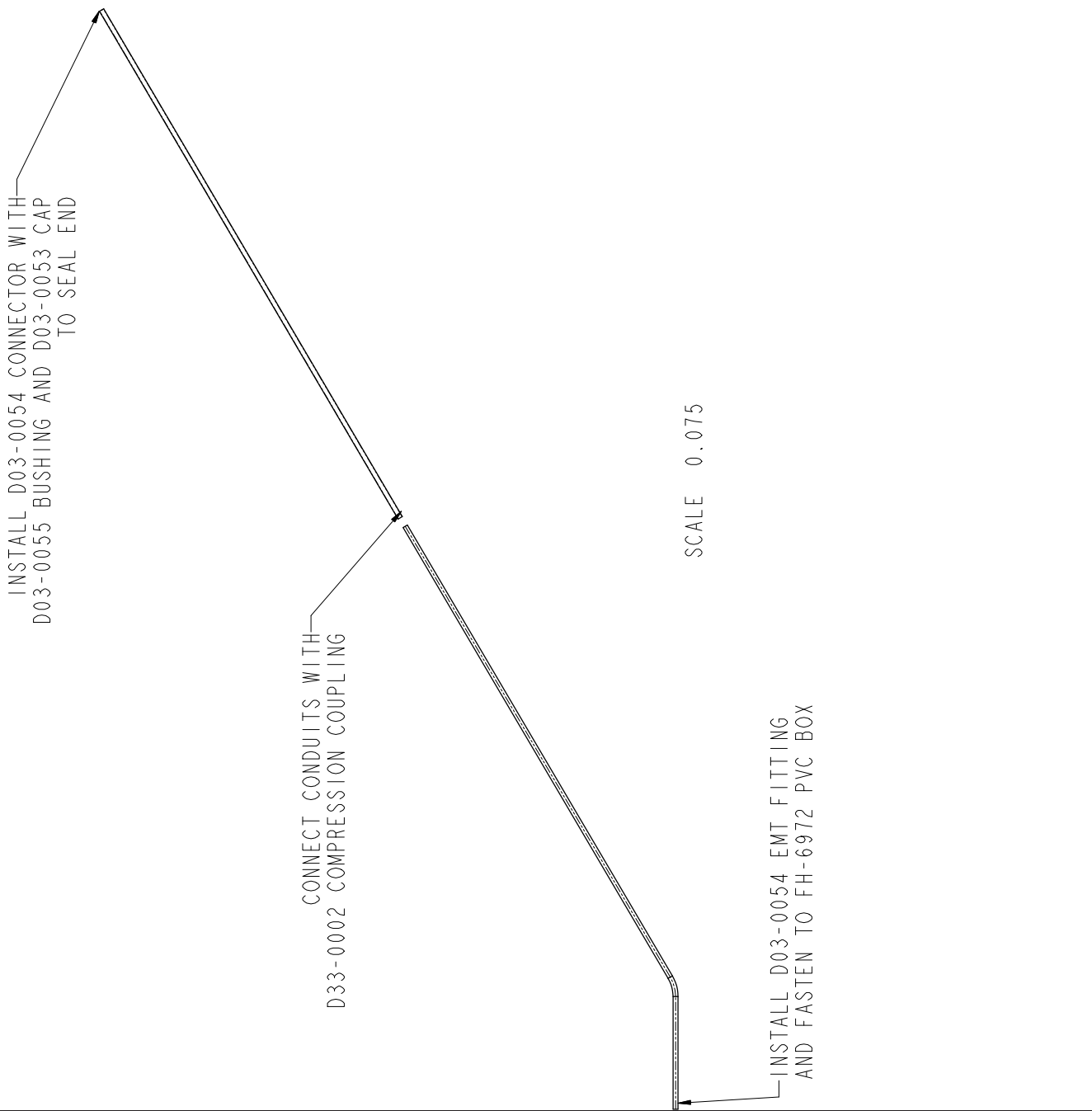

## Plenum Temperature Sensor

The plenum temperature sensor is the small grey PVC junction box attached by a cord to the fan/heater control box on the master fan/heater unit.

1. On the right side of the far right fan/heater, drill one 3/4" hole even with the fan/heater unit in a valley on the bin sidewall.
2. Insert the probe through the 3/4" hole.
3. Position the housing so the cord exits the housing horizontally, and the tabs fall on the sidewall peaks.
4. Use two self drilling screws to mount the housing to the bin sidewall.
5. Caulk between the housing and the sidewall to seal.



Plenum temperature sensor on the bin sidewall.

### IMPORTANT!

**If the Top Dry is a two fan unit, do not mount the plenum temperature sensor between the two fan/heater units.**

**Drying Chamber Overflow Rotary Switch**

1. Drill a 2" diameter hole through the roof panel at the location shown in Figure 5.
2. Use the mounting plate as a pattern and drill four 3/8" holes through the roof panel at the switch location, so the plate can be bolted to the roof.
3. Attach the flex coupling to the rotary switch power pack using a roll pin.
4. Apply teflon tape or pipe sealant (not included) to the rotary switch power pak threads and thread the rotary switch power pack into the mounting plate coupling.
5. Make sure the conduit hole is at right angles with the roof panel ribs or facing toward the eave.
6. Caulk the underside of the mounting plate and on all sides of the 2" hole.
7. Bolt the assembly to the roof panel.
8. Attach the 3-vane paddle to the flex coupling as shown in Figure 6.



**Drying chamber overflow rotary switch.**

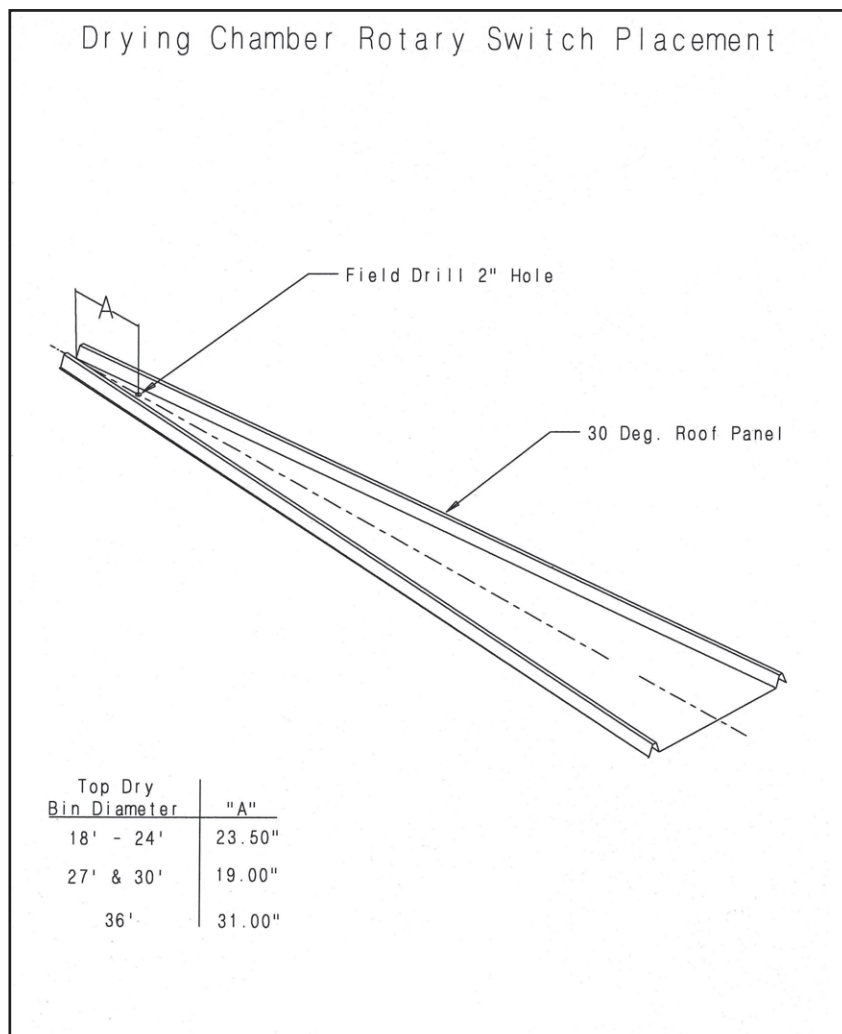

**Figure 5: Drying chamber rotary switch placement.**



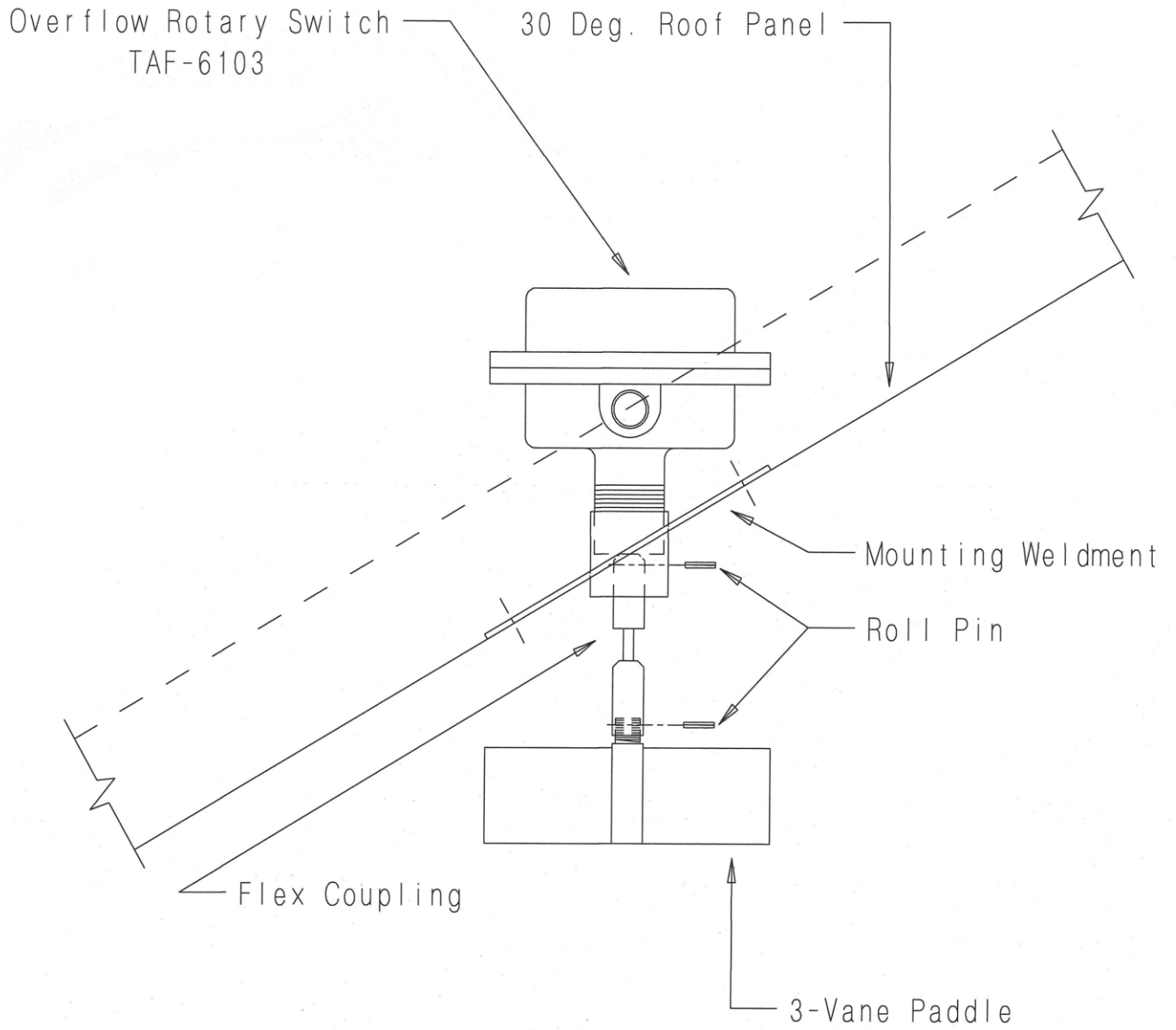

Figure 6: Drying chamber overflow rotary switch.

**Storage Chamber High Limit Rotary Switch**

1. Drill a 2” diameter hole through the sidewall 3’ below the fan/heater.
2. If the bin is 2.66” corrugation the hole should be centered on an outside hill.
3. If the bin is 4.00” corrugation the hole should be centered on an outside valley.
4. Use the mounting plate as a pattern and drill four 3/8” holes through the sidewall at the switch location so the plate can be bolted to the bin.
5. Add foam weather strip around the top and side of the mounting plate.
6. Caulk the underside of the mounting plate, on all sides of the 2” hole, and where the plate meets the bin.
7. Bolt the mounting plate to the sidewall.
8. Attach the flex coupling to the rotary switch power pack using a roll pin.
9. Attach the 1-vane paddle to the flex coupling as shown in Figure 7.
10. Apply teflon tape or pipe sealant (not included) to the rotary switch power pak threads and



**Storage chamber rotary switch.**

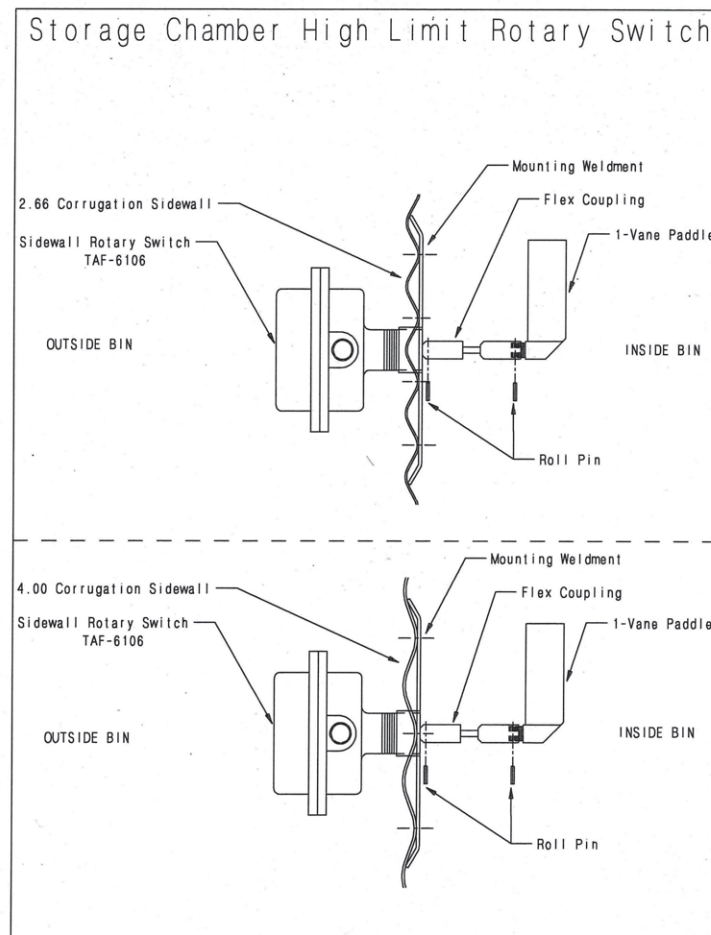

**Figure 7: Storage chamber high limit rotary switch.**

thread the rotary switch power pack into the mounting plate coupling.

11. Make sure the conduit hole is facing down or is horizontal.

**Liquid Propane (LP)**

Top Dry dryers have internal vaporizers, and they are designed to operate on liquid draw from the supply tank. Avoid using propane supply tanks that have been used for vapor draw for long periods of time. When using liquid draw systems any moisture that may be present in tanks or lines may freeze when the system is used in cold weather. To avoid this situation, purge the system with methanol. Do not use tanks which have previously been used for ammonia or fertilizer solutions. These substances are extremely corrosive and will damage fuel supply and burner parts. Because the vaporizer coil may need to be adjusted during operation flexible hose suitable for LPs should be used for the final field connection.

See the “Fuel Systems and Rec-

ommendations Chart” for liquid propane to determine the correct size line to run from the tank to the dryer. Have a qualified gas service person inspect the installation to be sure that everything is installed according to local codes and ordinances.

After installation is complete check all connections for leaks with liquid detergent or comparable. Wear rubber gloves and eye protection. Avoid contact with liquid propane. **DO NOT USE FLAME FOR LEAK TESTING.**

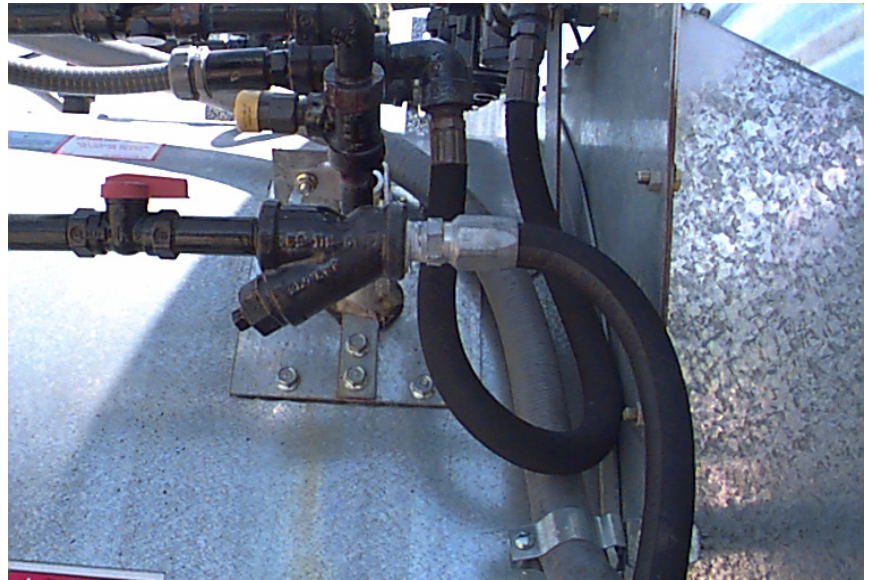

LP line field connection.

**Fuel System Specifications and Recommendations  
Liquid Propane (LP)**

Dryer Fan Size	Dryer Horsepower	Maximum Heat Capacity BTU Per Hour	Maximum Fuel Flow Gallons Per Hour	Minimum Line Size	Orifice Size	Minimum Operating Pressure	Maximum Operating Pressure
28	10-12	3 million	32	1/2	1/4	1 lb.	15 lbs.
36"	15	5 million	54	1/2"	21/64	1 lb.	15 lbs.
40	15	5.5 million	60	1/2"	11/32	1 lb.	15 lbs.
42"	30	9 million	95	1/2"	.328"	1 lb.	15 lbs.
42"	40	9.5 million	104	3/4"	29/64"	1 lb.	15 lbs.

**Natural Gas (NG)**

This dryer is designed to operate on natural gas. Natural gas units have a larger orifice to accommodate lower pressures sometimes found with natural gas and do not have vaporizer coils like liquid propane units. A regulated pressure of 10 PSI minimum, 30 maximum must be provided at the field connection point on the fan and heater unit, with gas available in sufficient volume to maintain the operating pressure.

See the “Fuel Systems and Recommendations Chart” for natural gas to determine the correct size line to run to the dryer. Have a qualified gas service person inspect the installation to be sure everything is installed

according to local codes and ordinances.

After installation is complete check all connections for leaks with liquid detergent or comparable. Wear rubber gloves and eye protection. **DO NOT USE FLAME FOR LEAK TESTING.**



**NG line field connection.**

**Fuel System Specifications and Recommendations  
Natural Gas (NG)**

Dryer Fan Size	Dryer Horsepower	Maximum Heat Capacity BTU Per Hour	Maximum Fuel Flow Cubic Ft. Per Hour	Minimum Line Size	Orifice Size	Minimum Operating Pressure	Maximum Operating Pressure
28	10-12	3 million	2970	1-1/2	3/8	1 lb.	7 lbs.
36	15	5 million	5280	2"	1/2"	1 lb.	7 lbs.
40	15	5.5million	5965	2"	17/32	1 lb.	7 lbs.
42	30	9 million	9536	2"	43/64	1 lb.	7 lbs.
42	40	9.5 million	10445	2"	45/64	1 lb.	7 lbs.

## Power Supply

An adequate power supply and proper wiring are important factors for maximum performance and long life of the dryer. Electrical service must be adequate enough to prevent low voltage damage to motors and control circuits (see Electrical Load Information).

## Transformer and Wiring Voltage Drop

It is necessary to know the distance from the unit to the available transformer, and the horsepower of your fan unit. Advise the service representative of your local power supplier that an additional load will be placed on the line. Each fan motor should be wired through a fused or circuit breaker disconnect switch. Check on KVA rating of transformers, considering total horsepower load. The power supply wiring, main switch equipment and transformers must provide adequate motor starting and operating voltage. Voltage drop during motor starting should not exceed 14% of normal voltage, and after motor is running at full speed it should be within 8% of normal voltage. Check Electrical Load Information for HP ratings and maximum amp loads to properly size wire and fusing elements. Standard electrical safety practices and codes should be used. (Refer to National Electrical Code Standard Handbook by National Fire Protection Association).

## Machine to Earth Grounding

It is very important that a *Machine To Earth Ground Rod* be installed at the fan. This is true even if there is a ground at the pole 15 feet away. Place the ground rod within 8 feet of the dryer and attach it to the dryer control panel with at least a #6 solid, bare, copper ground wire and the clamp provided. The grounding rod located at the power pole will not provide adequate grounding for the dryer. The proper grounding will provide additional safety in case of any short and will ensure long life of all circuit boards, and the ignition sys-

tem. The ground rod must be in accordance with local requirements.

## Proper Installation of Ground Rod

It is not recommended that the rod be driven into dry ground.

Follow these instructions for proper installation:

1. Dig a hole large enough to hold 1 to 2 gallons of water.
2. Fill hole with water.
3. Insert rod through water and jab it into the ground.
4. Continue jabbing the rod up and down. The water will work its way down the hole, making it possible to work the rod completely into the ground. This method of installing the rod gives a good conductive bond with the surrounding soil.
5. Connect the bare, copper ground wire to the rod with the proper ground rod clamp. See Figure 8.
6. Connect the bare copper ground wire to the fan control boxes with a grounding lug.



7. Ground wire must not have any breaks or splices.

**Dig a hole large enough to hold 1 or 2 gallons of water. Work the ground rod into the earth until it is completely in the ground.**

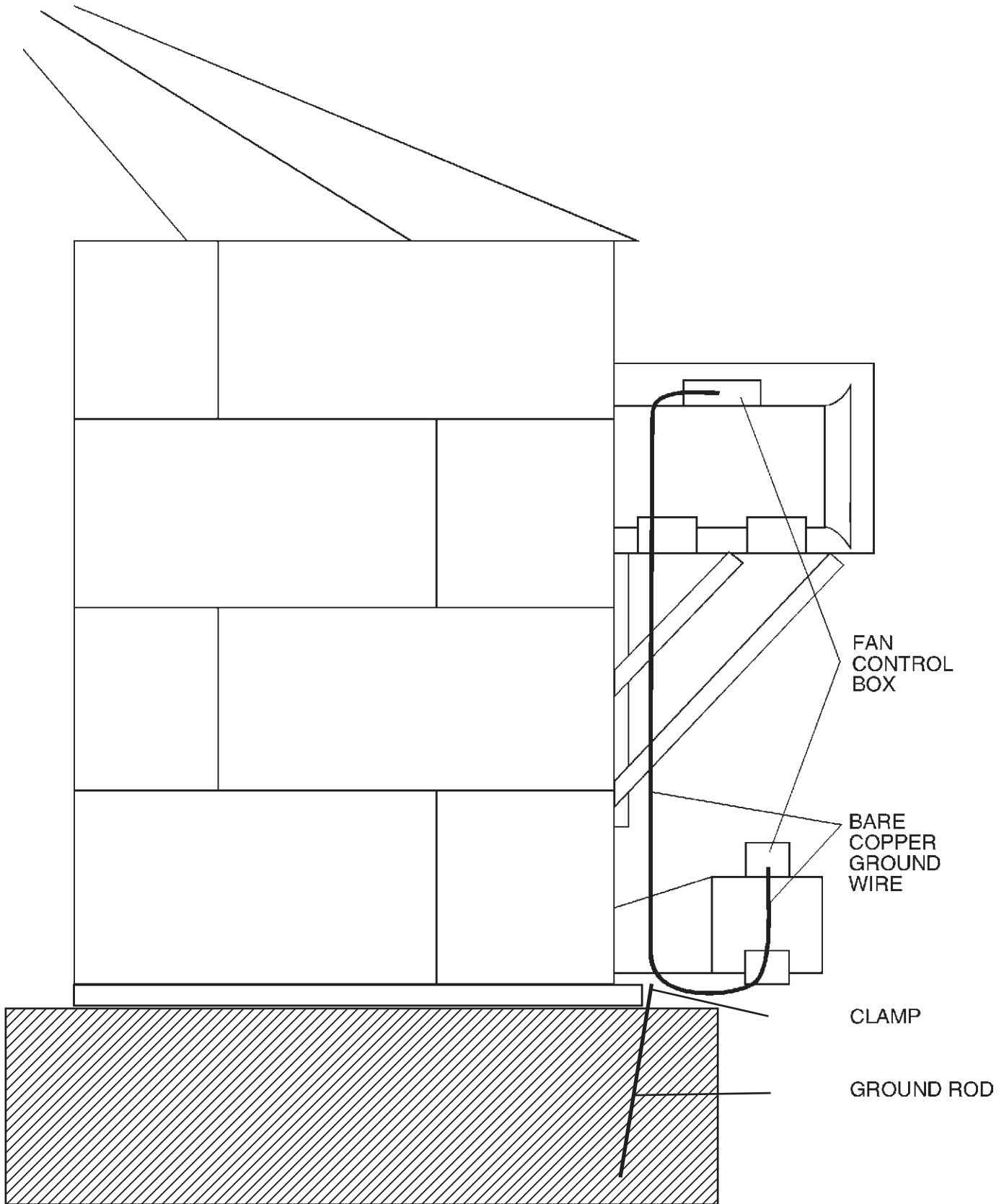

Figure 8: The Top Dry and ground rod attachment illustration.

The Following diagram details the configuration for correct main power installation. Use the diagram in conjunction with the Electrical Load information and Wire Size information provided. The diagram details the correct main power installation for 220v 1 ph, 230v ph, 460v 3ph, 575v 3ph, and 380v 3ph 50hz power supplies.

On all three phase systems put the leg with the highest potential difference between that leg and ground ( wild or high voltage leg) on the center terminal (L2) at the motor starter.

**NOTE: Standard electrical safety should be used. (Refer to the National Electrical Code Standard Handbook by the National Fire Protection Association). A qualified electrician should make all electrical wiring installations. Follow all local or national electrical safety standards and ordinances when installing the equipment.**

**Main Power Schematic**

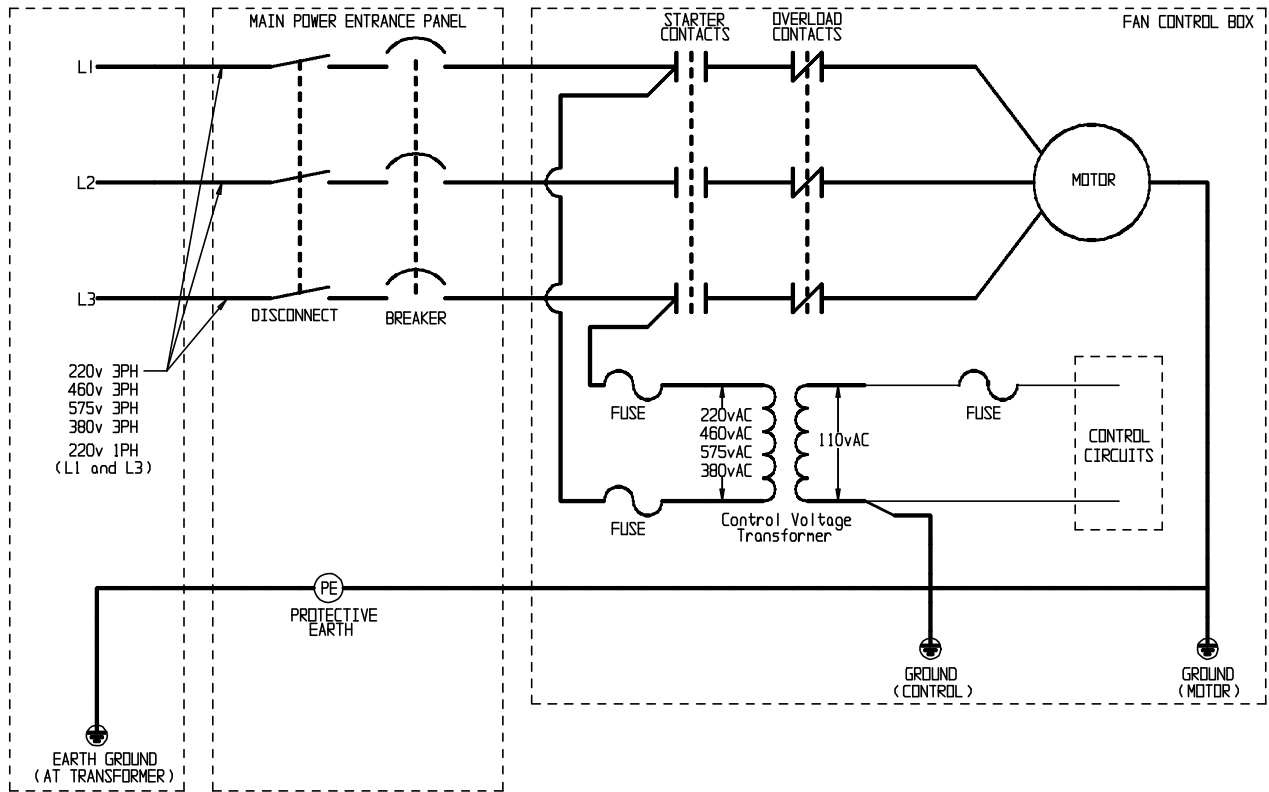

**Electrical Load Information**

The following charts provide information for the electrician wiring the grain dryer, and are a reference guide for parts. It is recommended that you contact your local power company and have a representatives survey the installation to see that your wiring is compatible with their system and that adequate power is supplied to your unit. Remember that the only thing connected to the recommended service amps should be your grain dryer. Standard electrical safety should be used. (Refer to the National Electrical Code Standard Handbook by the National Fire Protection Association). A qualified electrician should make all electrical wiring installations.

Dryer Fan Size	Voltage	Horsepower	Full Load Amps	Fuse (Slow Blow)	Breaker
28"	220v1ph	10-12	48	100	100
	208v3ph	10-12	35	80	80
	220v3ph	10-12	33	80	80
	380v50hz	10-12	15	40	40
	460v3ph	10-12	17	40	40
36"	575v3ph	10-12	15	40	40
	220v1ph	10-16	78	150	150
	208v3ph	15	44	125	125
	220v3ph	15	39	100	100
	380v50hz	15	27	80	80
40"	460v3ph	15	20	50	50
	575v3ph	15	16	40	40
	220v1ph	10-16	78	150	150
	208v3ph	15	44	125	125
	220v3ph	15	39	100	100
42"	380v50hz	15	27	80	80
	460v3ph	15	20	50	50
	575v3ph	15	16	40	40
	208v3ph	30	80	150	150
	220v3ph	30	74	150	150
42"	380v50hz	30	39	100	100
	460v3ph	30	37	100	100
	575v3ph	30	30	80	80
	208v3ph	40	108	200	200
	220v3ph	40	102	200	200
42"	380v50hz	40	47	100	100
	460v3ph	40	51	100	100
	575v3ph	40	40	100	100



### Stand Alone Fan/Heater

The Series 2000 Top Dry master fan/heater can operate as a stand alone fan/heater unit. If installed as a stand alone unit no control center is used, all timers and temperatures are set at the fan/heater unit, and the unit is stopped and started at the fan/heater. To wire the Series 2000 Fan/heater unit as a stand alone unit do the following:

1. Place (1) jumper between terminal #2 and terminal #3 in the master fan/heater control box.
2. Figure #14 details the placement of the jumper.

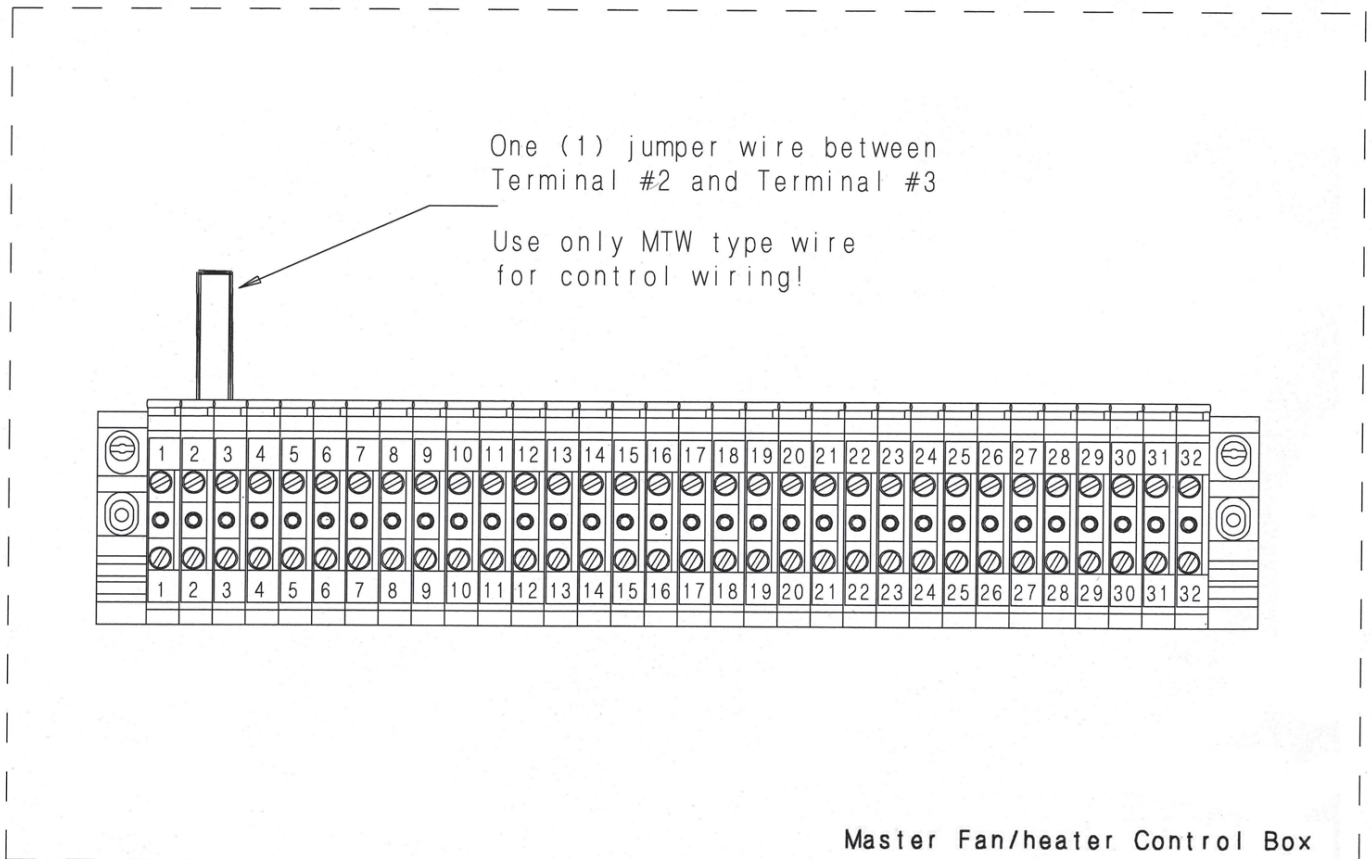

Figure 14: Wiring for a stand alone fan/heater unit.

**Economy Control  
Center Interconnect**

The Series 2000 Top Dry Economy Control Center allows the fan/heater unit(s) to be stopped and started at the economy control center. All timers and temperatures are set at the fan/heater unit(s). To wire the economy control center to the master fan/heater unit do the following:

NOTE: Do NOT use solid wire for interconnection.

1. Run four (4) 16ga MTW/THHN type wires from the economy control center to the master fan/heater unit.
2. Connect the wires as shown in figure #15.

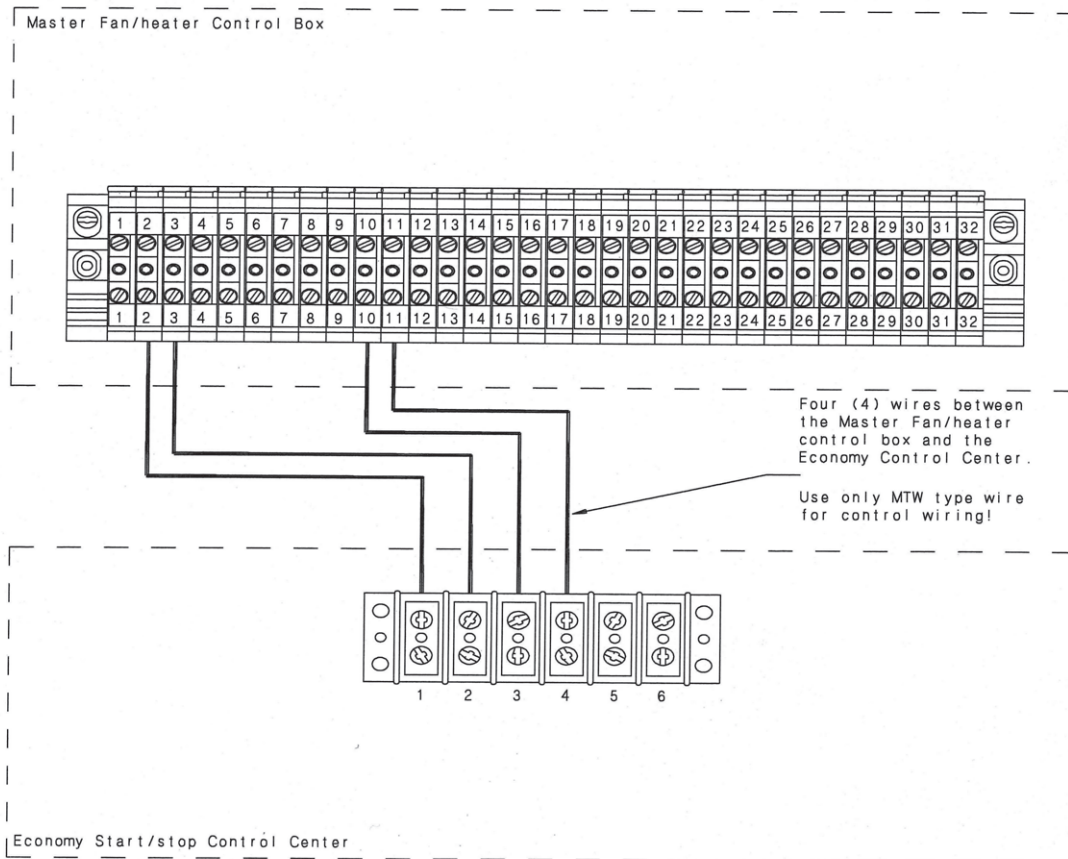

**Figure 15: Wiring for the economy control center to the master fan/heater unit.**

### Manual Control Center Interconnect

The Series 2000 Top Dry Manual Control Center allows the fan/heater unit(s) to be stopped and started, and all timers and temperatures to be set at the manual control center. To wire the manual control center to the master fan/heater unit do the following:

NOTE: Do NOT use solid wire for interconnection.

1. Run five (5) 16ga MTW/THHN type wires from the manual control center to the master fan/heater unit.
2. Connect the wires as shown in figure #16.

NOTE: A shielded 16 gauge cable is recommended for use on the network connection. The network wires for this configuration are attached to terminals number 4 and 5. Ground each end of the shielded cable to the housing. A shielded 16 gauge 2 wire cable can be purchased from GSI.

Part # WR-16 / 2S

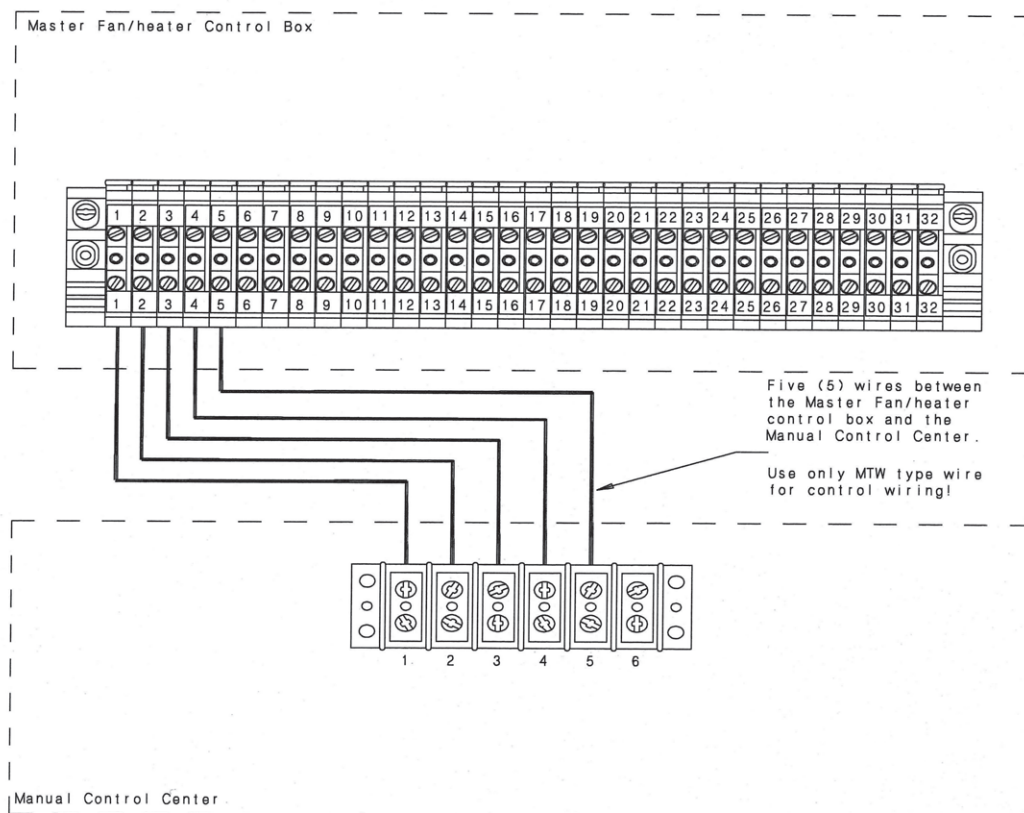

Figure 16: Wiring for the manual control center to the master fan/heater unit.

### Master to Slave Interconnect

A slave fan/heater unit can be added to operate in unison with the master fan/heater unit. The interconnect between the master and slave fan/heater units remains the same regardless of the type or presence of a control center. To wire a slave fan/heater unit to a master fan/heater unit do the following:

NOTE: Do NOT use solid wire for interconnection.

1. Run four (4) 16ga MTW/THHN type wires from the master fan/heater unit to the slave fan/heater unit.
2. Connect the wires as shown in figure #17.

NOTE: A shielded 16 gauge cable is recommended for use on the network connections. The network connections for this configuration are attached to terminals number 8 and 9 in the master unit and terminals number 3 and 4 in the slave unit. Ground each end of the shielded cable to the housing. A shielded 16 gauge 2 wire cable can be purchased from GSI. Part # WR-16 / 2S.

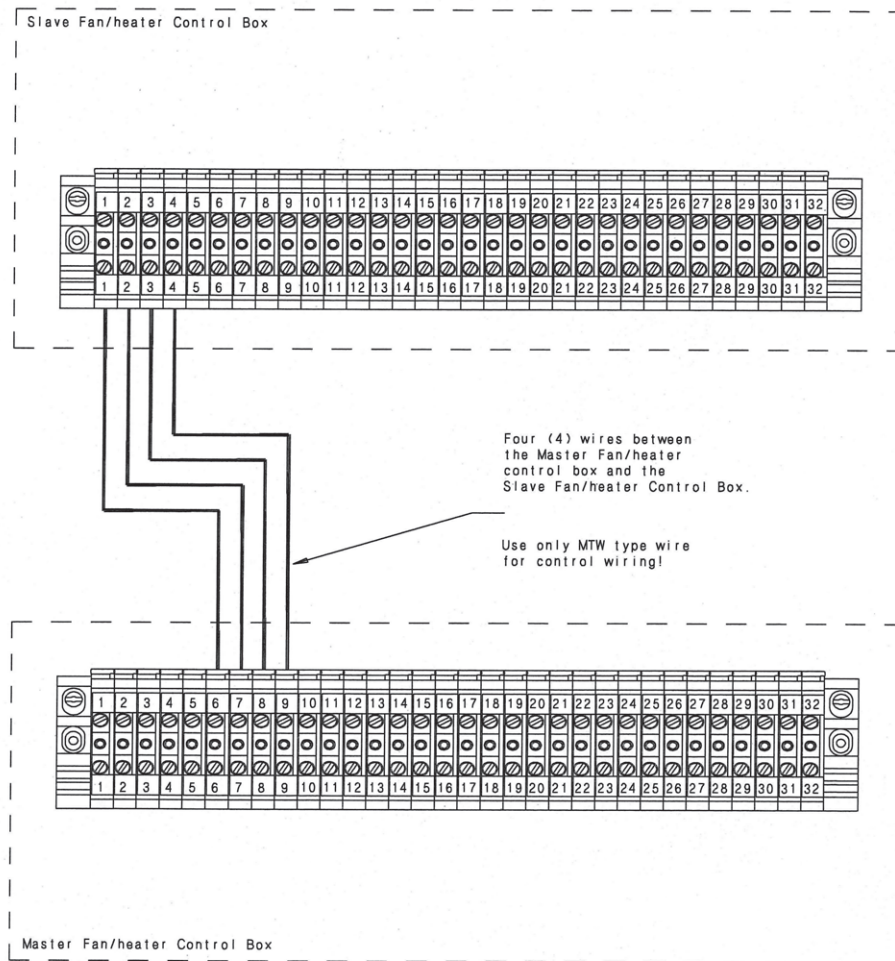

Figure 17: Wiring for a slave fan/heater unit to a master fan/heater unit.

### Slave to Slave Interconnect

A second slave fan/heater unit can be added to operate in unison with the master fan/heater unit and another slave fan/heater unit. This would create a three fan unit. The interconnect between the first slave fan/heater unit and the second slave fan/heater unit remains the same regardless of the type or presence of a control center. To wire a second slave fan/heater unit to another slave fan/heater unit do the following:

NOTE: Do NOT use solid wire for inter-connection.

1. Run four (4) 16ga MTW/THHN type wires from the first slave fan/heater unit to the second slave fan/heater unit.
2. Connect the wires as shown in figure #18.

NOTE: A shielded 16 gauge cable is recommended for use on the network connections. The network connections for this configuration are attached to terminals number 7 and 8 in slave #1 and terminals number 3 and 4 in slave #2. Ground each end of the shielded cable to the housing. A shielded 16 gauge 2 wire cable can be purchased from GSI. Part #WR-16 / 2S

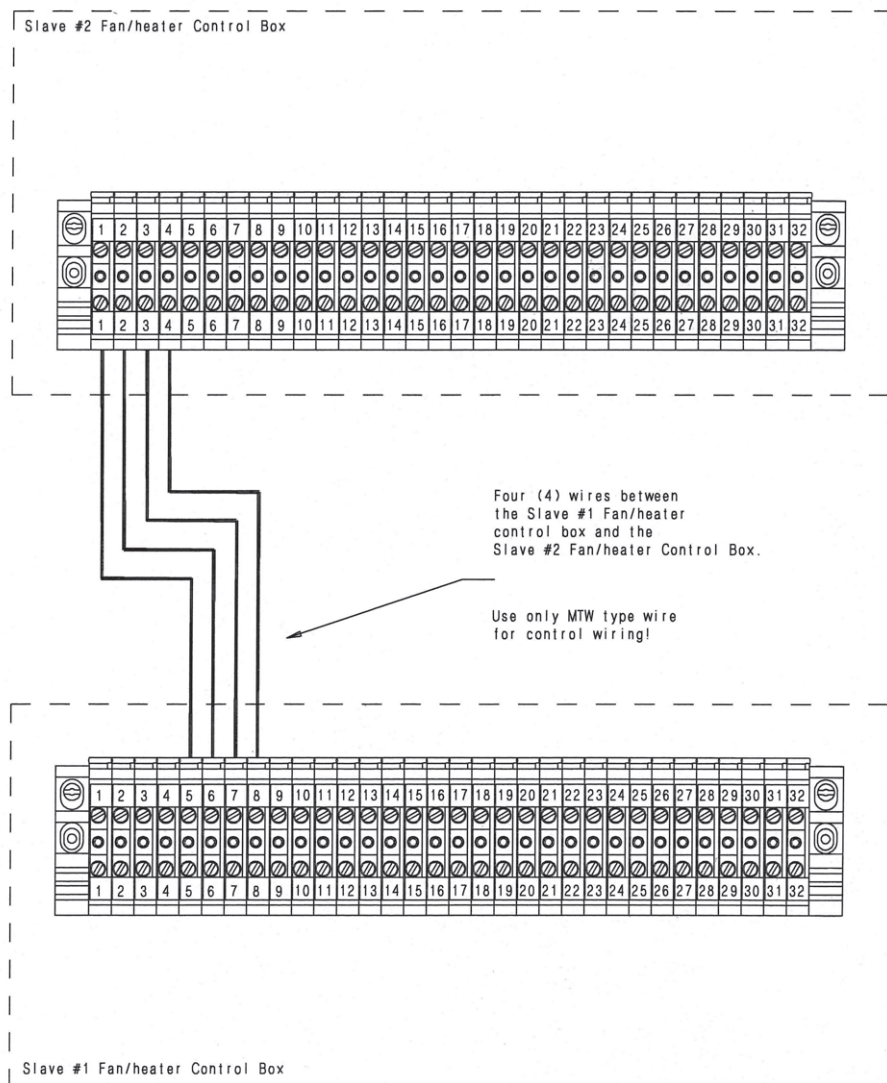
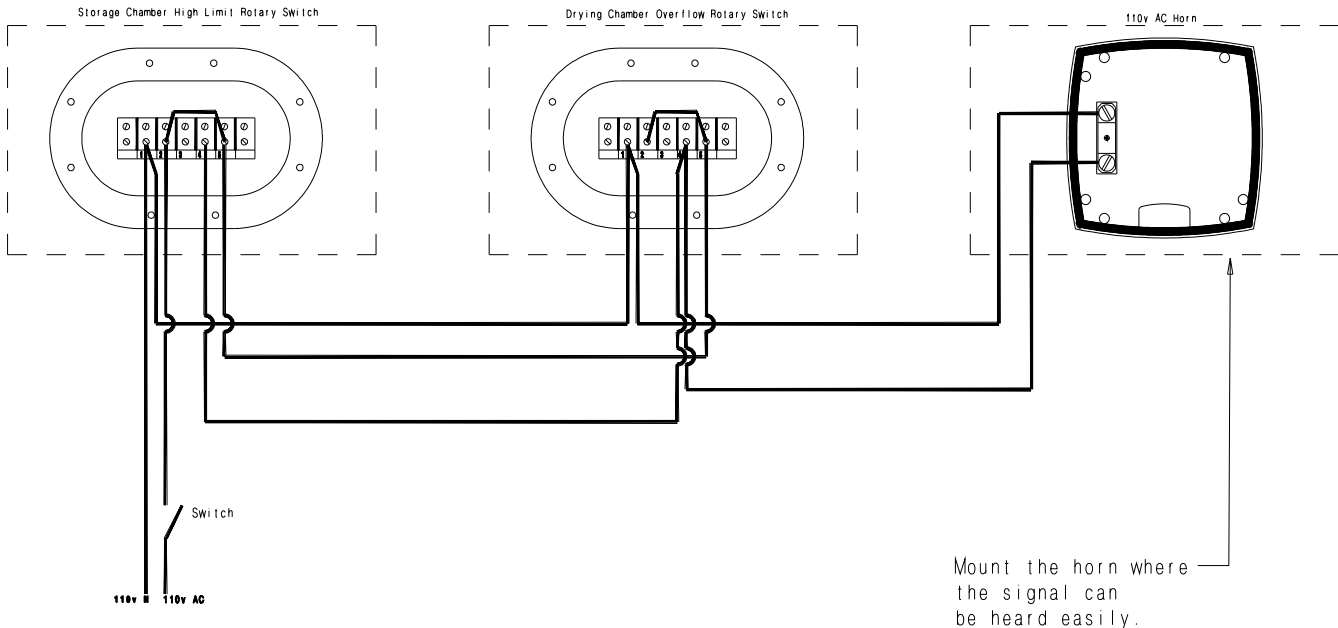

Figure 18: Wiring for a second slave fan/heater unit to another slave fan/heater unit.

**Rotary Switch and  
Horn Wiring**

A drying chamber overflow rotary switch and a storage chamber high level rotary switch can be used to let the operator know when the drying chamber or the storage chamber is full. Figure #19 details one possible way of wiring both the drying chamber and the storage chamber rotary switches so that the horn will sound when either the drying chamber or the storage chamber is full. To wire the rotary switches and the horn do the following:

1. Run two (2) wires between an on/off switch and the storage chamber rotary switch.
2. Run three (3) wires between the storage chamber rotary switch and the drying chamber rotary switch.
3. Run two (2) wires between the drying chamber rotary switch and the horn.
4. Connect the wires as shown in Figure #19



**Figure 19: Wiring for the rotary switches and horn.**

THE GSI GROUP, INC. ("GSI") WARRANTS ALL PRODUCTS MANUFACTURED BY GSI TO BE FREE OF DEFECTS IN MATERIAL AND WORKMANSHIP UNDER NORMAL USAGE AND CONDITIONS FOR A PERIOD OF TWELVE MONTHS AFTER RETAIL SALE TO THE ORIGINAL END USER OF SUCH PRODUCTS. GSI'S ONLY OBLIGATION IS, AND PURCHASER'S SOLE REMEDY SHALL BE FOR GSI, TO REPAIR OR REPLACE, AT GSI'S OPTION AND EXPENSE, PRODUCTS THAT, IN GSI'S SOLE JUDGMENT, CONTAIN A MATERIAL DEFECT DUE TO MATERIALS OR WORKMANSHIP. ALL DELIVERY AND SHIPMENT CHARGES TO AND FROM GSI'S FACTORY WILL BE PURCHASER'S RESPONSIBILITY. EXPENSES INCURRED BY OR ON BEHALF OF THE PURCHASER WITHOUT PRIOR WRITTEN AUTHORIZATION FROM AN AUTHORIZED EMPLOYEE OF GSI SHALL BE THE SOLE RESPONSIBILITY OF THE PURCHASER.

EXCEPT FOR THE ABOVE STATED EXPRESS LIMITED WARRANTIES, GSI MAKES NO WARRANTY OF ANY KIND, EXPRESSED OR IMPLIED, INCLUDING, WITHOUT LIMITATION, WARRANTIES OF MERCHANTABILITY OR FITNESS FOR A PARTICULAR PURPOSE OR USE IN CONNECTION WITH (i) PRODUCT MANUFACTURED OR SOLD BY GSI OR (ii) ANY ADVICE, INSTRUCTION, RECOMMENDATION OR SUGGESTION PROVIDED BY AN AGENT, REPRESENTATIVE OR EMPLOYEE OF GSI REGARDING OR RELATED TO THE CONFIGURATION, INSTALLATION, LAYOUT, SUITABILITY FOR A PARTICULAR PURPOSE, OR DESIGN OF SUCH PRODUCT OR PRODUCTS.

IN NO EVENT SHALL GSI BE LIABLE FOR ANY DIRECT, INDIRECT, INCIDENTAL OR CONSEQUENTIAL DAMAGES, INCLUDING, WITHOUT LIMITATION, LOSS OF ANTICIPATED PROFITS OR BENEFITS. PURCHASER'S SOLE AND EXCLUSIVE REMEDY SHALL BE LIMITED TO THAT STATED ABOVE, WHICH SHALL NOT EXCEED THE AMOUNT PAID FOR THE PRODUCT PURCHASED. THIS WARRANTY IS NOT TRANSFERABLE AND APPLIES ONLY TO THE ORIGINAL PURCHASER. GSI SHALL HAVE NO OBLIGATION OR RESPONSIBILITY FOR ANY REPRESENTATIVE OR WARRANTIES MADE BY OR ON BEHALF OF ANY DEALER, AGENT OR DISTRIBUTOR OF GSI.

GSI ASSUMES NO RESPONSIBILITY FOR FIELD MODIFICATIONS OR ERECTION DEFECTS WHICH CREATE STRUCTURAL OR STORAGE QUALITY PROBLEMS. MODIFICATIONS TO THE PRODUCT NOT SPECIFICALLY COVERED BY THE CONTENTS OF THIS MANUAL WILL NULLIFY ANY PRODUCT WARRANTY THAT MIGHT HAVE BEEN OTHERWISE AVAILABLE.

THE FOREGOING WARRANTY SHALL NOT COVER PRODUCTS OR PARTS WHICH HAVE BEEN DAMAGED BY NEGLIGENT USE, MISUSE, ALTERATION OR ACCIDENT. THIS WARRANTY COVERS ONLY PRODUCTS MANUFACTURED BY GSI. THIS WARRANTY IS EXCLUSIVE AND IN LIEU OF ALL OTHER WARRANTIES EXPRESS OR IMPLIED. GSI RESERVES THE RIGHT TO MAKE DESIGN OR SPECIFICATION CHANGES AT ANY TIME.

PRIOR TO INSTALLATION, PURCHASER HAS THE RESPONSIBILITY TO RESEARCH AND COMPLY WITH ALL FEDERAL, STATE AND LOCAL CODES WHICH MAY APPLY TO THE LOCATION AND INSTALLATION



a division of

---

THE GSI GROUP

---



1004 E. Illinois St.  
Assumption, IL 62510  
Phone 217-226-4421  
Fax 217-226-4498

November 2004