



TopDry Autoflow Control

Installation Manual

PNEG-900

Version: 4.1

Date: 01-12-16



This equipment shall be installed in accordance with the current INSTALLATION CODES FOR GAS BURNING APPLIANCES AND EQUIPMENT, CAN1_B149.1 and B149.2 or applicable provincial regulations which should be carefully followed in all cases. Authorities having jurisdiction should be consulted before installations are made.

Contents

Chapter 1 Safety	4
Safety Guidelines	4
Cautionary Symbols Definitions	5
Safety Cautions	6
Safety Sign-Off Sheet	12
Chapter 2 Decals	13
Chapter 3 Installation	16
Fan/Heater Mounting	16
Autoflow Control Box Mounting	16
Series 2000 Autoflow Control Box Bolt Pattern	18
Control Box Mounting	19
Multi-Grain Temperature Sensor	23
Close-Up Detail of Grain Temperature Sensor Wiring	24
Grain Temperature Sensor Mounted to Leveling Band Post	25
Plenum Temperature Sensor	26
Plenum High-Limit Installation	28
TopDry Plenum High-Limit Installation	29
Optional Wet Supply Rotary Switch Installation	30
Storage Chamber High-Limit Rotary Switch Installation	32
Drying Chamber Rotary Switches Mounted in Bin Roof	34
Drying Chamber Low-Level Rotary Switch Installation	35
Drying Chamber High-Level Rotary Switch Installation	37
Drying Chamber Overflow Rotary Switch Installation	38
Liquid Propane (LP)	39
Natural Gas (NG)	40
Chapter 4 Electrical Power Supply	41
Conduit Runs	41
Grounding	42
Power Supply	42
Transformer and Wiring Voltage Drop	42
Machine to Earth Grounding	42
Power/Motor Wiring	43
Electrical Load Information	44
Connect Autoflow to Control Fan 1	46
Control Fan 1 to Fan 2 Interconnect	47
Autoflow to Actuator Interconnect	48
Autoflow to Optional Wet Supply Rotary Switch Interconnect	49
Autoflow to Storage Chamber Rotary Switch Interconnect	50
Autoflow to Drying Chamber Rotary Switches Interconnect	50
TopDry Bin Switch Changes	52
Autoflow to Fill System Control Box Interconnect	54
Autoflow to Ground Interconnect	55
Fan 2 to Fan 3 Interconnect	56
Chapter 5 Warranty	57

1. Safety

Safety Guidelines

Safety guidelines are general-to-specific safety rules that must be followed at all times. This manual is written to help you understand safe operating procedures and problems that can be encountered by the operator and other personnel when using this equipment. Save these safety guidelines for future reference.

As owner or operator, you are responsible for understanding the requirements, hazards, and precautions that exist and to inform others as required. Unqualified persons must stay out of the work area at all times.

Alterations shall not be made to the equipment. Alterations can produce dangerous situations resulting in **SERIOUS INJURY or DEATH**.

This equipment must be installed in accordance with the current installation codes and applicable regulations, which must be carefully followed in all cases. Authorities having jurisdiction must be consulted before installations are made.

When necessary, you must consider the installation location relative to electrical, fuel and water utilities.

Personnel operating or working around equipment must read this manual. This manual shall be delivered with equipment to its owner. Failure to read this manual and its safety instructions is a misuse of the equipment.

ST-0001-3

Cautionary Symbols Definitions

Cautionary symbols appear in this manual and on product decals. The symbols alert the user of potential safety hazards, prohibited activities and mandatory actions. To help you recognize this information, we use the symbols that are defined below.



This symbol indicates an imminently hazardous situation which, if not avoided, **will result in serious injury or death.**



This symbol indicates a potentially hazardous situation which, if not avoided, **can result in serious injury or death.**



This symbol indicates a potentially hazardous situation which, if not avoided, **can result in minor or moderate injury.**



This symbol is used to address practices not related to personal injury.



This symbol indicates a general hazard.



This symbol indicates a prohibited activity.

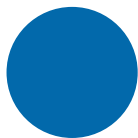

This symbol indicates a mandatory action.

ST-0005-2

Safety Cautions

Use Personal Protective Equipment

- Use appropriate personal protective equipment:

Eye Protection



Respiratory Protection



Foot Protection



Hearing Protection



Head Protection



Fall Protection



Hand Protection



- Wear clothing appropriate to the job.
- Remove all jewelry.
- Tie long hair up and back.

ST-0004-1

Follow Safety Instructions

- **Warning:** If the information in the manual is not followed exactly, a fire or explosion can result, causing property damage, personal injury or loss of life.
- Carefully read all safety messages in this manual and safety signs on your machine. Keep signs in good condition. Replace missing or damaged safety signs. Be sure new equipment components and repair parts include the current safety signs. Replacement safety signs are available from the manufacturer.
- Learn how to operate the machine and how to use controls properly. Do not let anyone operate without instruction.
- If you do not understand any part of this manual or need assistance, contact your dealer.



ST-0025-2

Maintain Equipment and Work Area

- Understand service procedures before doing work.
- Keep area clean and dry.
- Do not service equipment while it is operating. Disconnect and lock-out power and fuel supply before entering equipment or before performing maintenance.
- Keep your equipment in proper working condition. Replace worn or broken parts immediately.
- Depressurize the fuel train before disassembling for service.
- Allow the fan to operate for 20 minutes with the burner off to purge products of combustion and to cool the components before entering.
- Check regularly for any developing gas plumbing leaks. Do not operate the dryer if any gas leak is detected. Shut down and repair before further operation.



ST-0030-2

For Your Safety

- If you smell gas:
 - Do not try to light any appliance.
 - Extinguish any open flames.
 - Do not touch any electrical switch.
 - Immediately call your gas supplier. Follow the gas supplier's instructions.
 - If you cannot reach your gas supplier, call the fire department.
- The use and storage of gasoline and other flammable vapors and liquids in open containers in the vicinity of this appliance is hazardous.
- Improper installation, adjustment, alteration, service or maintenance can cause property damage, injury or death. Read the installation, operating and maintenance instructions thoroughly before installing or servicing this equipment. Installation and service must be performed by a qualified installer, service agency or the gas supplier.



ST-0024-1

1. Safety

Install and Operate Electrical Equipment Properly

- Electrical controls must be installed by a qualified electrician and must meet the standards set by the National Electric Code, Canadian Electrical Code, and all local and state codes.
- Lock-out power source before making adjustments, cleaning, or maintaining equipment.



ST-0027-2

Handle and Use Equipment Properly

- Equipment is intended for the use of grain drying only. Any other use is a misuse of this equipment.
- The operating instructions in this manual pertain to the common cereal grains as indicated. When drying any other grain, contact GSI for additional recommendations.
- On LP fired units, set pressure regulator to avoid excessive gas pressure applied to the burner during ignition and operation. Do not exceed maximum recommended drying temperatures.
- Equipment has sharp edges that can cause serious injury. To avoid injury, handle sharp edges with caution and use proper protective clothing and equipment at all times.
- All guards must be in place before and during operation. Images of guards removed in this manual are for illustration purposes only.
- Use caution when working around high-speed fans, gas burners, augers and auxiliary conveyors which can start automatically.
- Keep hands, feet, and clothing away from moving parts.
- Do not bypass any safety device or interlock.
- Do not enter the dryer or bin while it is operating.
- Do not operate in an area where combustible material will be drawn into the dryer.

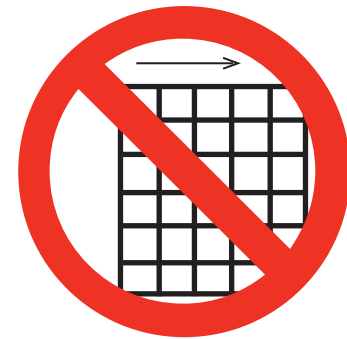

ST-0029-2

Exercise Caution When Drying Flammable Grains

- Be aware that some grains are highly flammable including, but not limited to, rapeseed, canola, linseed, sunflower and milo.
- All grain and seed must be whole (minimal cracking or crushing), clean, and dust free before drying.
- Avoid dust and chaff from being drawn into the fan and heater.
- To reduce risk of fire, keep the fan, heater, drying plenum, and ducts clean at all times.
- In the event of a fire (or suspected fire):
 1. Shut down the entire dryer.
 2. Turn off the fuel at the tank or supply valve.
 3. Shut off and lock electrical power.
 4. Evacuate the area.
 5. Call the fire department.



ST-0032-1

Prevent Roof Damage Due to Vacuum Pressure

- Roof damage can result from excessive vacuum or internal pressure from fans or other air moving systems. The manufacturer does not warrant this type of roof damage.
- Adequate ventilation or “makeup air” devices must be provided for all powered air handling systems.
- The manufacturer does not recommend the use of downward flow systems (suction).
- Severe roof damage can result from any blockage of air passages.
- Operating fans during high humidity or cold weather conditions can cause air exhaust or intake ports to freeze.

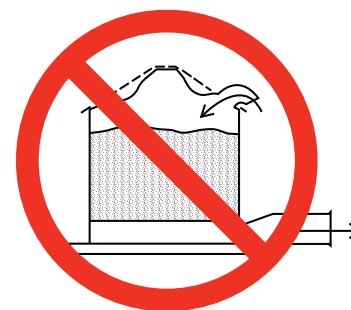

ST-0028-2

1. Safety

Install and Operate Gas-Fired Equipment Properly

- Gas-fired equipment should be installed by a qualified pipe fitter and must conform with local codes.
- For Canada: The equipment shall be installed in accordance with the *Natural Gas and Propane Installation Code, CSA B149.1*, or the *Propane Storage and Handling Code, CSA B149.2*, or applicable provincial regulations, which should be carefully followed in all cases. Authorities having jurisdiction should be consulted before installations are made.
- For the United States: The equipment shall be installed in accordance with the *National Fuel Gas Code ANSI Z223.1/NFPA 54*.



ST-0016-2

Confined Space Hazards and Entry Procedures

- Note that the interior of this equipment is considered a confined space. Maintenance of this equipment can require access to the confined space.
- Access doors must be shut and locked except when access is required.
- Doors giving access to dangerous equipment must be safety interlocked.
- The following entry procedures must be followed:
 - Be aware of all possible hazards present inside the confined space and wear personal protective equipment (PPE) as needed.
 - Complete a permit to work and follow all permit required confined space entry procedures defined by the site manager.
 - Make sure that the area has been purged of any hazardous products or gases. Check the atmosphere for harmful gases or vapors with a suitable gas analyzer and make sure levels are safe before entering.
 - Do not smoke or use naked flames.
 - Lock out and tag out power supplies and fuel supplies to all equipment.
 - Do not work alone. Work in teams of at least three so that help is immediately available in the event of an emergency.
 - Confirm that all personnel have safely exited the equipment and tools have been recovered once work is complete.



ST-0055-1

Do Not Enter Bin

- Rotating flighting will kill or dismember.
- Flowing material will trap and suffocate.
- Crusted material will collapse and suffocate.
 - If you must enter the bin:
 1. Shut off and lock out all power sources.
 2. Use a safety harness and safety line.
 3. Station another person outside the bin.
 4. Avoid the center of the bin.
 5. Wear proper breathing equipment or respirator.







ST-0061-1

Install safety decals on components as shown in this section. Always ensure that safety decals are in a place, easily readable and in good condition. If a decal cannot be easily read for any reason or has been painted over, replace it immediately.

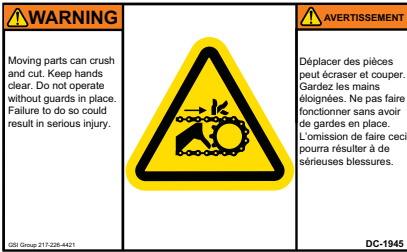

To replace a damaged or missing decal, contact us to receive a free replacement.

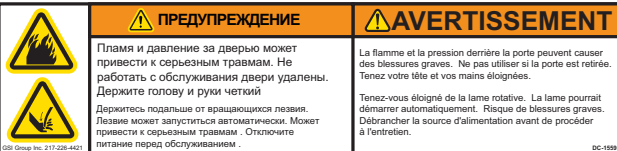

GSI Decals

1004 E. Illinois St.
Assumption, IL 62510
Tel: 1-217-226-4421

Location	Decal No.	Decals	Description
Control Box	DC-889	 <p>The decal features a yellow triangular warning symbol with a hand being struck by a lightning bolt. To the right, a red header reads 'DANGER' with a warning triangle icon. Below, the text reads: 'HIGH VOLTAGE Will cause injury or death. Lockout power before servicing.' The GSI logo and part number DC-889 are at the bottom.</p>	Danger, High Voltage
Chute Control (Autoflow Only)	DC-1945	 <p>The decal contains three sections. On the left, a yellow 'WARNING' header is above the text: 'Moving parts can crush and cut. Keep hands clear. Do not operate without guards in place. Failure to do so could result in serious injury.' In the center is a yellow triangular symbol with a hand near a rotating gear. On the right, a yellow 'AVERTISSEMENT' header is above the text: 'Déplacer des pièces peut écraser et couper. Gardez les mains éloignées. Ne pas faire fonctionner sans avoir de gardes en place. L'omission de faire ceci pourra résulter à de sérieuses blessures.' The GSI logo and part number DC-1945 are at the bottom.</p>	Warning, Moving Parts
Chute Control (Autoflow Only)	DC-1948	 <p>The decal features a red 'DANGER' header on the left with the text: 'HIGH VOLTAGE Will cause serious injury or death. Lockout power before servicing.' In the center is a yellow triangular symbol with a hand being struck by a lightning bolt. On the right, another red 'DANGER' header is above the text: 'HAUTE TENSION Causera de sérieuses blessures ou la mort. Couper/verrouiller le courant avant l'entretien.' The GSI logo and part number DC-1948 are at the bottom.</p>	Danger, High Voltage
Above access door on heater housing	DC-1718	 <p>The decal contains three sections. On the left, a yellow 'CAUTION' header is above the text: 'Do not operate above rated maximum BTU output. Fire damage to grain product and drying structure will occur. Refer to operator's manual for burner specifications.' In the center is a yellow triangular symbol with a flame. On the right, a yellow 'ATTENTION' header is above the text: 'Ne pas faire fonctionner au-dessus du rendement maximum coté de BTU. Des dommages de feu au produit de grain et à la structure de séchage se produiront. Vous référer au manuel de l'opérateur pour les spécifications sur le brûleur.' The GSI logo and part number DC-1718 are at the bottom.</p>	Caution, Grain Damage
Above access door on heater housing	DC-1702	 <p>The decal contains three sections. On the left, a blue 'NOTICE' header is above the text: 'Thermostat must be installed for operation. Failure to do so may damage equipment and cause fire.' In the center is a yellow triangular symbol with a flame. On the right, another blue 'NOTICE' header is above the text: 'Le thermostat doit être installé pour fonctionner. Omettre cette installation peut endommager l'équipement et provoquer un feu.' The GSI logo and part number DC-1702 are at the bottom.</p>	Notice, Use Thermostat
Above access door on heater housing	DC-1559	 <p>The decal contains three sections. On the left, two yellow triangular symbols: one with a flame and one with a hand being struck. In the center, a yellow 'ПРЕДУПРЕЖДЕНИЕ' header is above the text: 'Пламя и давление за дверью может привести к серьезным травмам. Не работайте с обслуживания двери удалены. Держите голову и руки четкий. Держитесь подальше от вращающихся лезвия. Лезвие может запуститься автоматически. Может привести к серьезным травмам. Отключите питание перед обслуживанием.' On the right, a yellow 'AVERTISSEMENT' header is above the text: 'La flamme et la pression derrière la porte peuvent causer des blessures graves. Ne pas utiliser si la porte est retirée. Tenez votre tête et vos mains éloignées. Tenez-vous éloigné de la lame rotative. La lame pourrait démarrer automatiquement. Risque de blessures graves. Débrancher la source d'alimentation avant de procéder à l'entretien.' The GSI logo and part number DC-1559 are at the bottom.</p>	Warning, Sharp Edges, Flame and Pressure

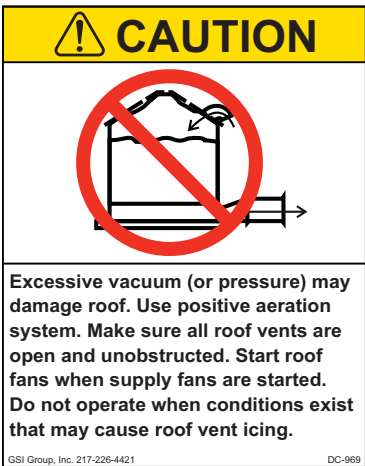
2. Decals

Location	Decal No.	Decals	Description
Control Box	DC-1224		Danger, High Voltage
Control Box	DC-1165		Danger, High Voltage
Located on duct access doors.	DC-973		Danger, Automatic Equipment
Located next to aeration system.	DC-969		Caution, Vacuum Pressure

Location	Decal No.	Decals	Description
On bin door covers.	DC-GBC-1A		Danger, Keep Clear of Augers
On bin door covers.	DC-GBC-2A		Warning, Unload Instructions

3. Installation

Fan/Heater Mounting

1. Inspect the duct system for proper installation per instructions in the TopDry erection manual.
2. Mount the fan/heater to duct using the appropriate face plate. Legs of the fan/heater should rest firmly and level on the concrete pad. (Refer to PNEG-1089 for more information.)

Autoflow Control Box Mounting



Figure 3A Autoflow Control Box Mounted on Bin

NOTE: Do not install this control panel near any transformers or any other device that will produce an electro magnetic field. Never run control wiring together with any wires that have amperage or voltage. Controllers can be mounted remotely with customer supplied conduit, but there must be a line of sight to the fans and heaters.

1. The Autoflow control box should be mounted at eye-level. Make sure to mount the Autoflow control box so that the fan/heater unit(s) are in view.
2. Keep in mind that wire will be used to interconnect the Autoflow control box with the fan/heater unit(s), fill system control box, actuator and all rotary switches.
3. Use the hole pattern in *Figure 3C on Page 18* to drill holes for mounting the Autoflow control box.

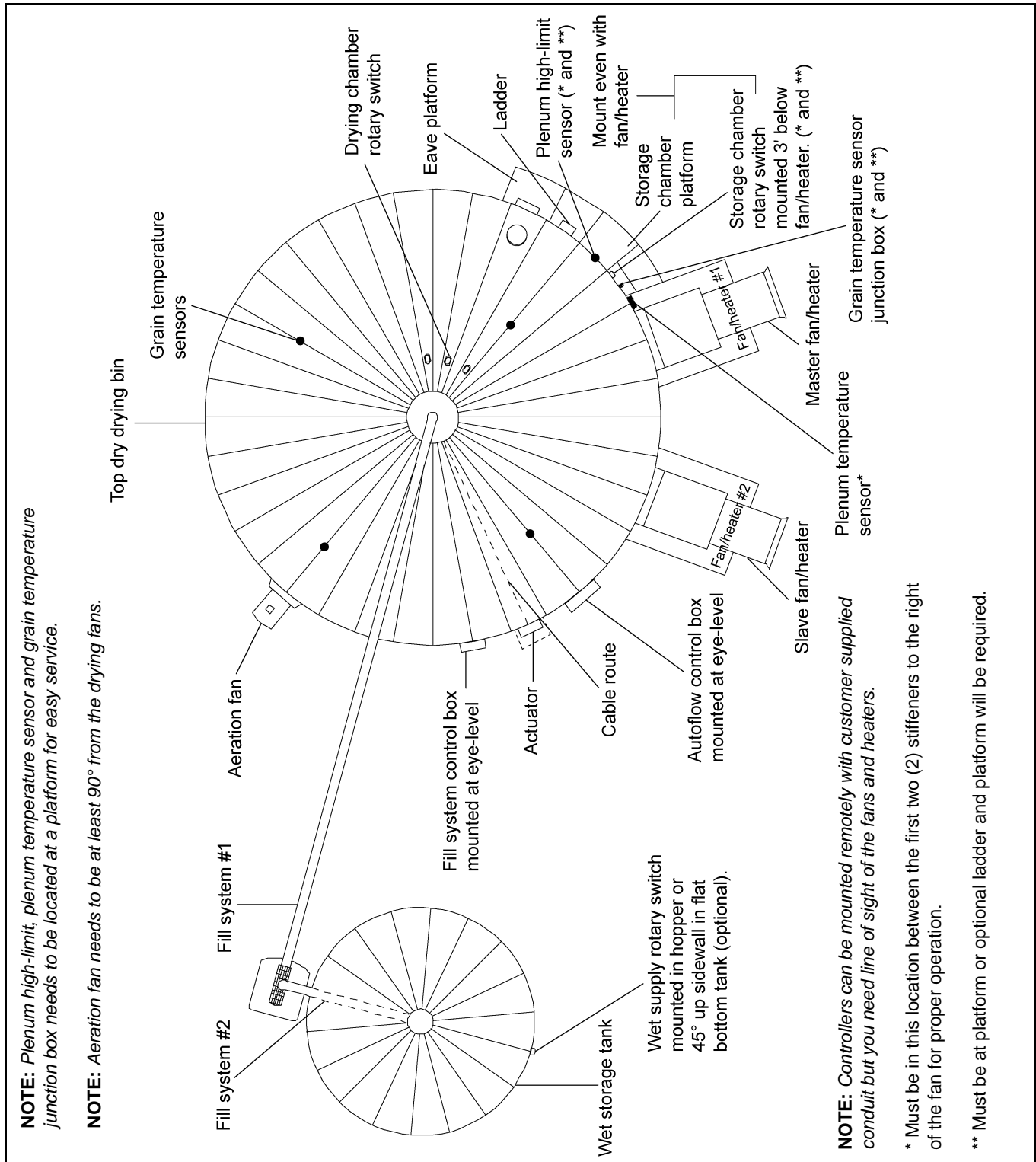

Figure 3B Component Placement

3. Installation

Series 2000 Autoflow Control Box Bolt Pattern

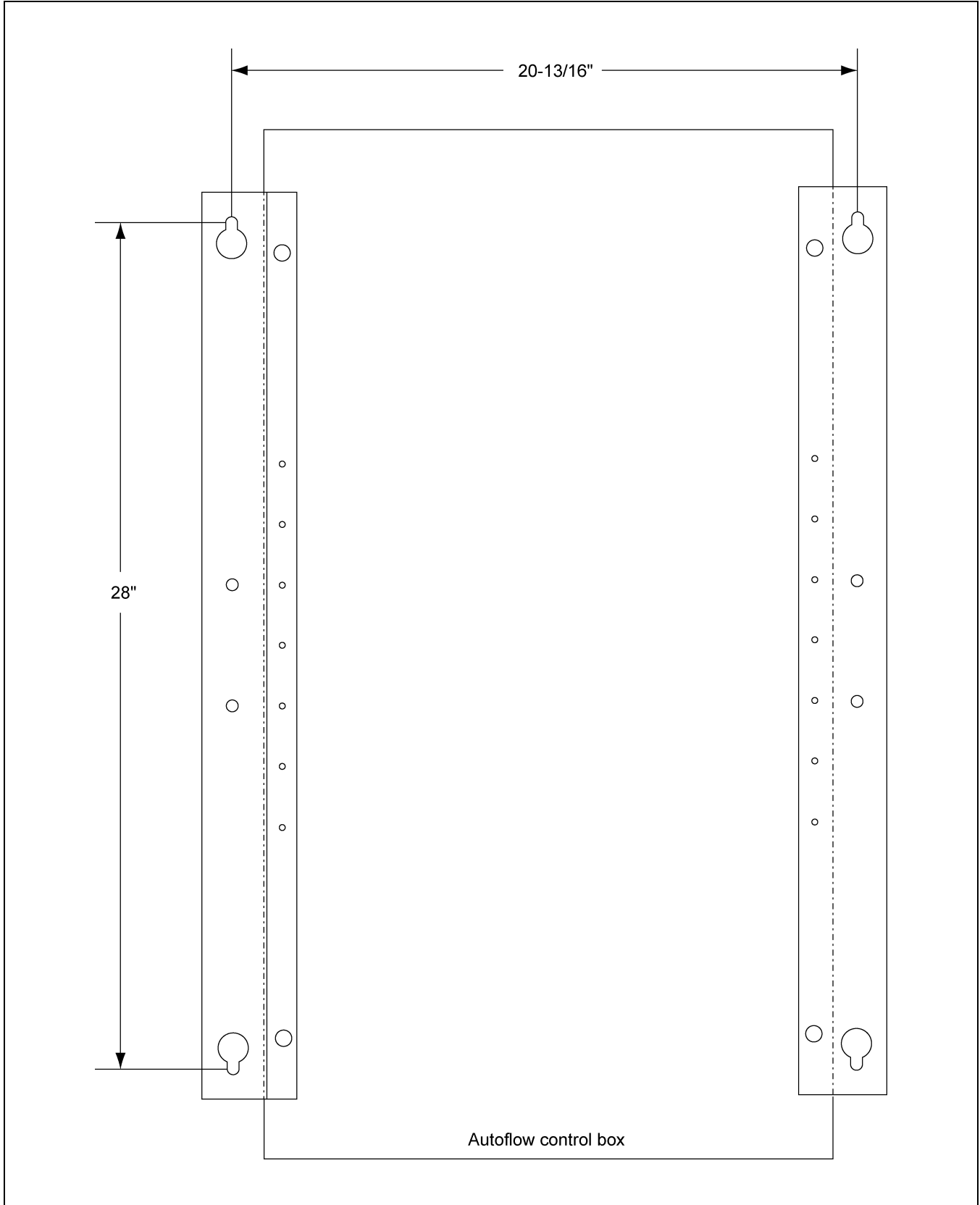

Figure 3C *Illustration of the bolt pattern for the autoflow control box.*

Control Box Mounting

Fill System Control Box Mounting

NOTE: *The control box can be mounted remotely with customer supplied conduit and wire within 100'. There must be a clear line of sight from a remote location for safe operation.*

1. The fill system control box should be mounted at eye-level. Make sure to install the fill system control box so that the fill system(s) and aeration fan are in view.
2. Keep in mind that wire will be used to interconnect the fill system control box with the Autoflow control box; and, that power wires will have to be run from the entrance panel to the fill system control box to power the fill system and aeration fan motors, which will also run from the fill system control box.
3. Use the pattern in [Figure 3E on Page 20](#) to drill holes for the fill system control box, if the box is to be mounted to the side of the bin.



Figure 3D *Fill System Control Box Mounted to Bin*

3. Installation

Fill System Control Box Bolt Pattern

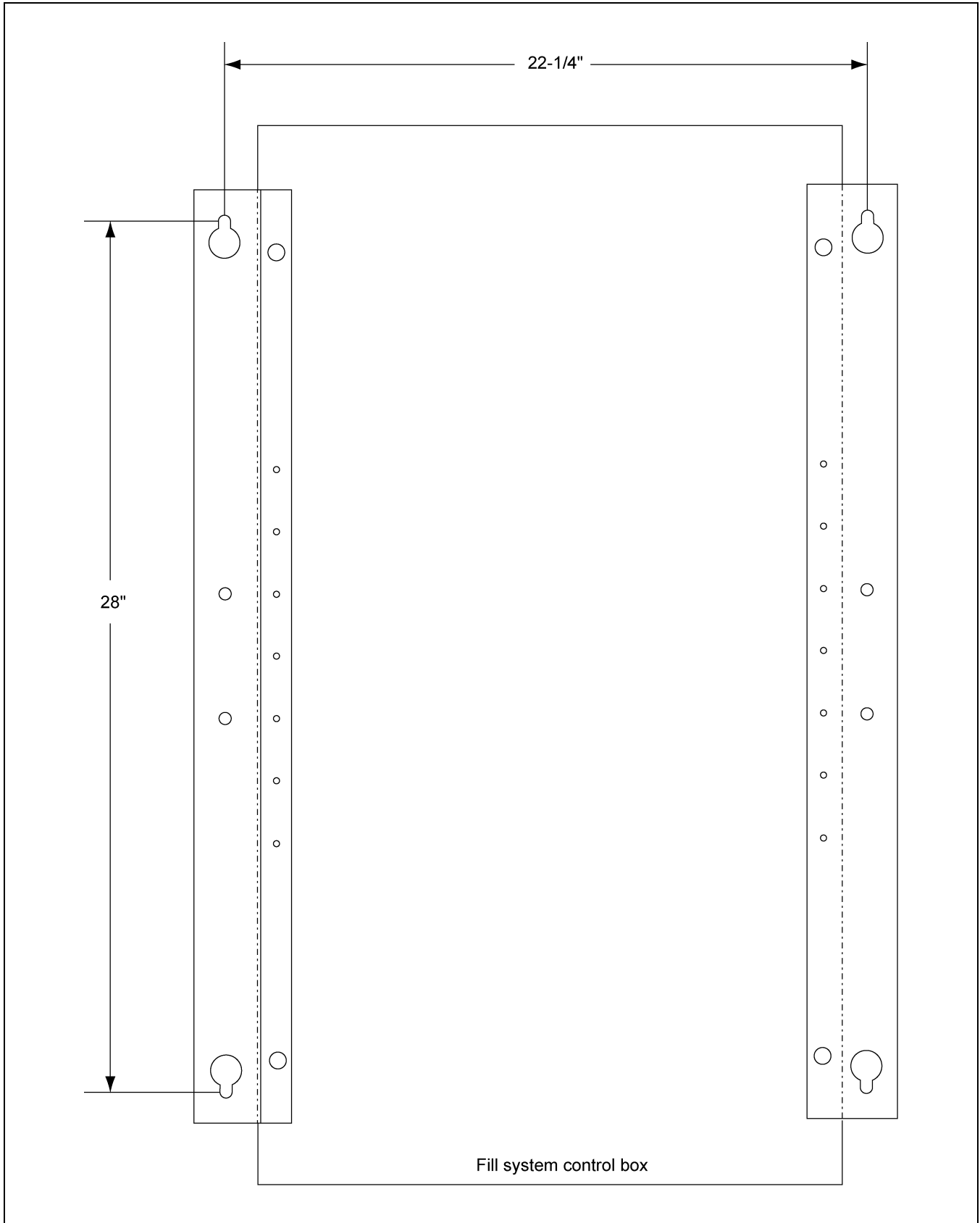

Figure 3E *Illustration of the bolt pattern for the fill system control box.*

Actuator Control Box Mounting

NOTE: *Never run control wiring together with motor wires that have any amperage or voltage.*

1. Mark the third sidewall ring from the ground to indicate the cable path if dump chutes and cable are already installed.
2. Make sure that all dump chutes and chains are EVENLY adjusted so that when one chute is level the others are level as well.
3. Keep in mind that wire will be used to interconnect the actuator control box with the chute control box; and, that a 110V power supply will need to run from the entrance panel to the actuator control box to power the 24V DC battery charger.
4. Use the pattern in [Figure 3H on Page 22](#) to drill holes for the actuator control box.
5. If the horizontal seam bolts are within 1" horizontally of the hole pattern shown, existing holes may be used to attach the actuator.
6. Use four (4) 5/16" x 1-1/4" bin bolts and washers with bolt heads to the inside of the bin.
7. Do not attach the dump chute cable to the actuator at this time. The cable should not be installed until after the actuator unit is completely wired and tested.

NOTE: *A new Chute Controller started shipping in late 2012 that does not use batteries. It can be retrofitted with the addition of one wire from the control box to the new controller. There is a separate Installation Manual PNEG-1894 which includes the wiring changes available for the new Chute Controller.*



Figure 3F *Old Actuator Control Box Mounted to Bin*



Figure 3G *New Chute Controller*

3. Installation

Actuator Control Box Mounting (Continued)

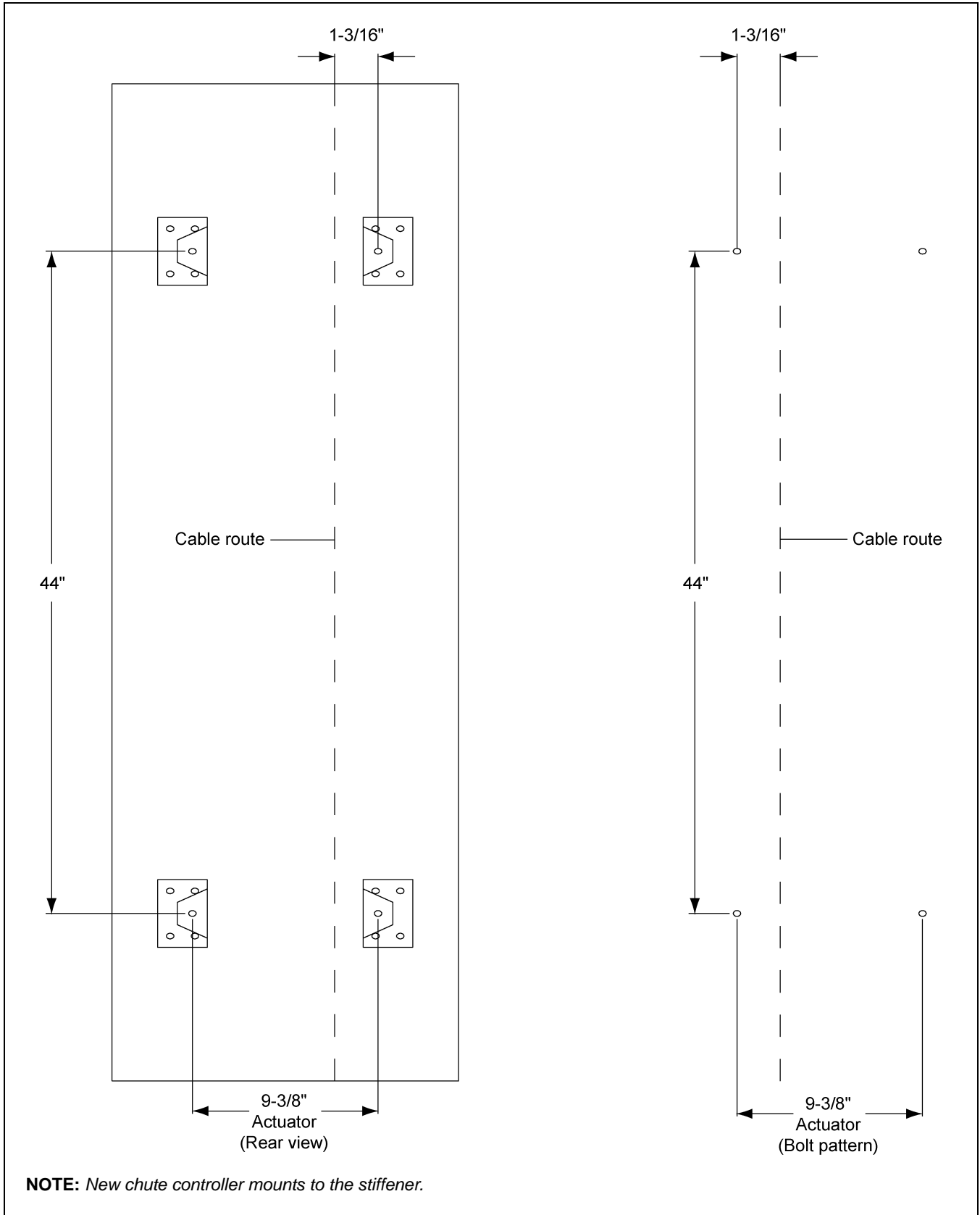

Figure 3H Old Style Bolt Pattern to Drill Holes for the Actuator Control Box

Multi-Grain Temperature Sensor

1. Remove the two (2) wires attached to the grain temperature sensor connected to terminal #22 and terminal #23 in the fan control box.
2. Mount the four (4) grain temperature sensor brackets evenly around the drying chamber on outside leveling band posts. (See Figure 3K on Page 25.)
3. Mount the brackets with bin bolts so that the sensor is 8-1/2" above the floor sheet rib for AUTO drying mode and 17-1/2" above the floor sheet rib for BATCH drying mode. For AUTO drying, the bottom hole in the mounting bracket should align with the third hole from the bottom of the leveling band post. For BATCH drying, the bottom hole in the mounting bracket should align with the eighth hole from the bottom of the leveling band post.
4. Wire tie the cords so they feed up the leveling band post and across the top leveling band.
5. Route the cords through the space between the roof and the top sidewall sheet. There should be enough on all temperature sensor brackets to exit the drying chamber at the same place.

NOTE: The cords must never have splices or connections made inside of the bin.

6. Route the cords into the junction box after the junction box has been mounted to the bin. This box must be located where it can be easily accessed for service from a platform. It may also be located for access from the ground using a junction box and additional cord (not supplied).
7. Wire the four (4) temperature sensors as shown in Figure 3I and on Page 24.

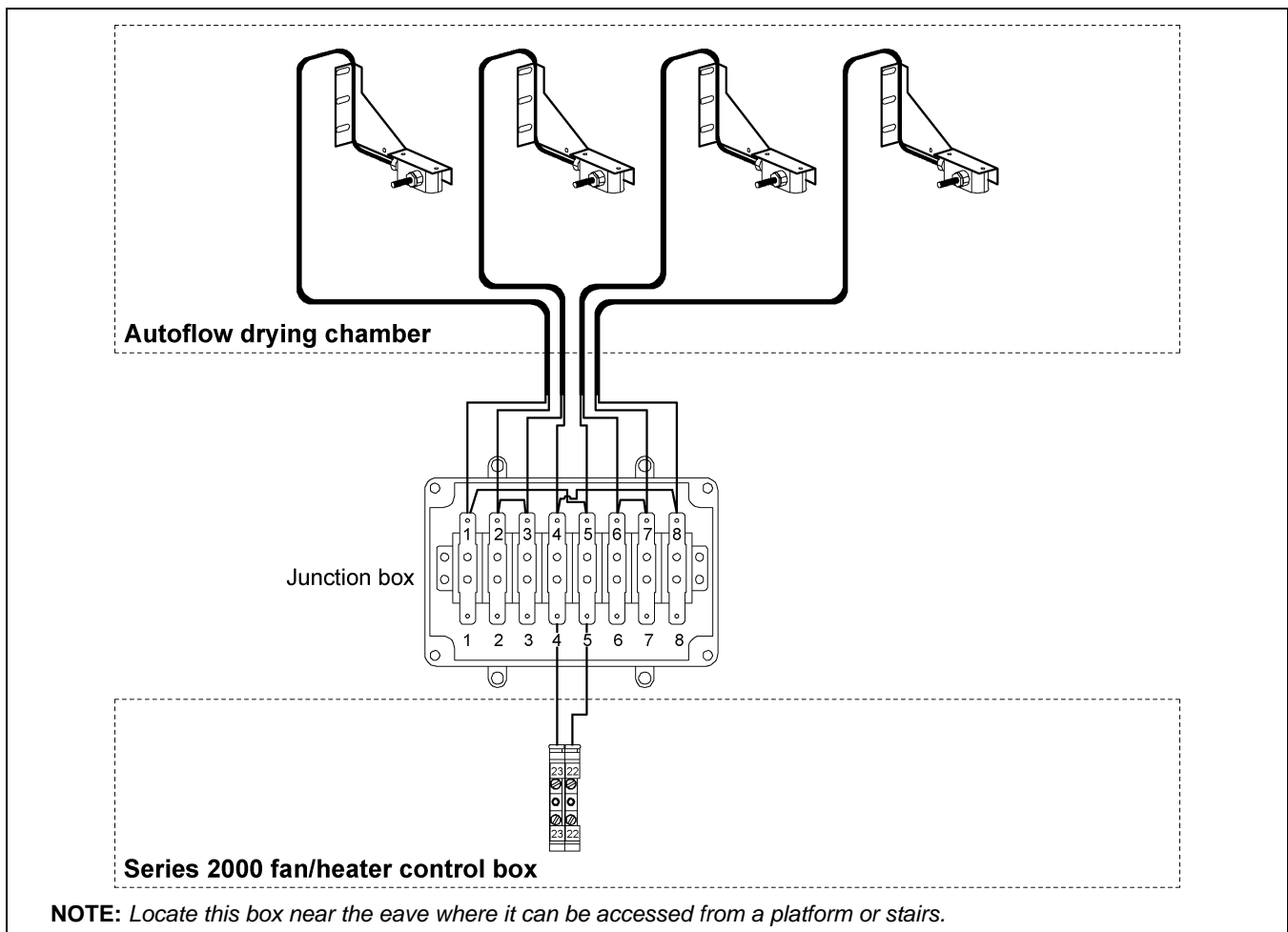

Figure 3I Illustration of the grain temperature sensor interconnection.

3. Installation

Close-Up Detail of Grain Temperature Sensor Wiring

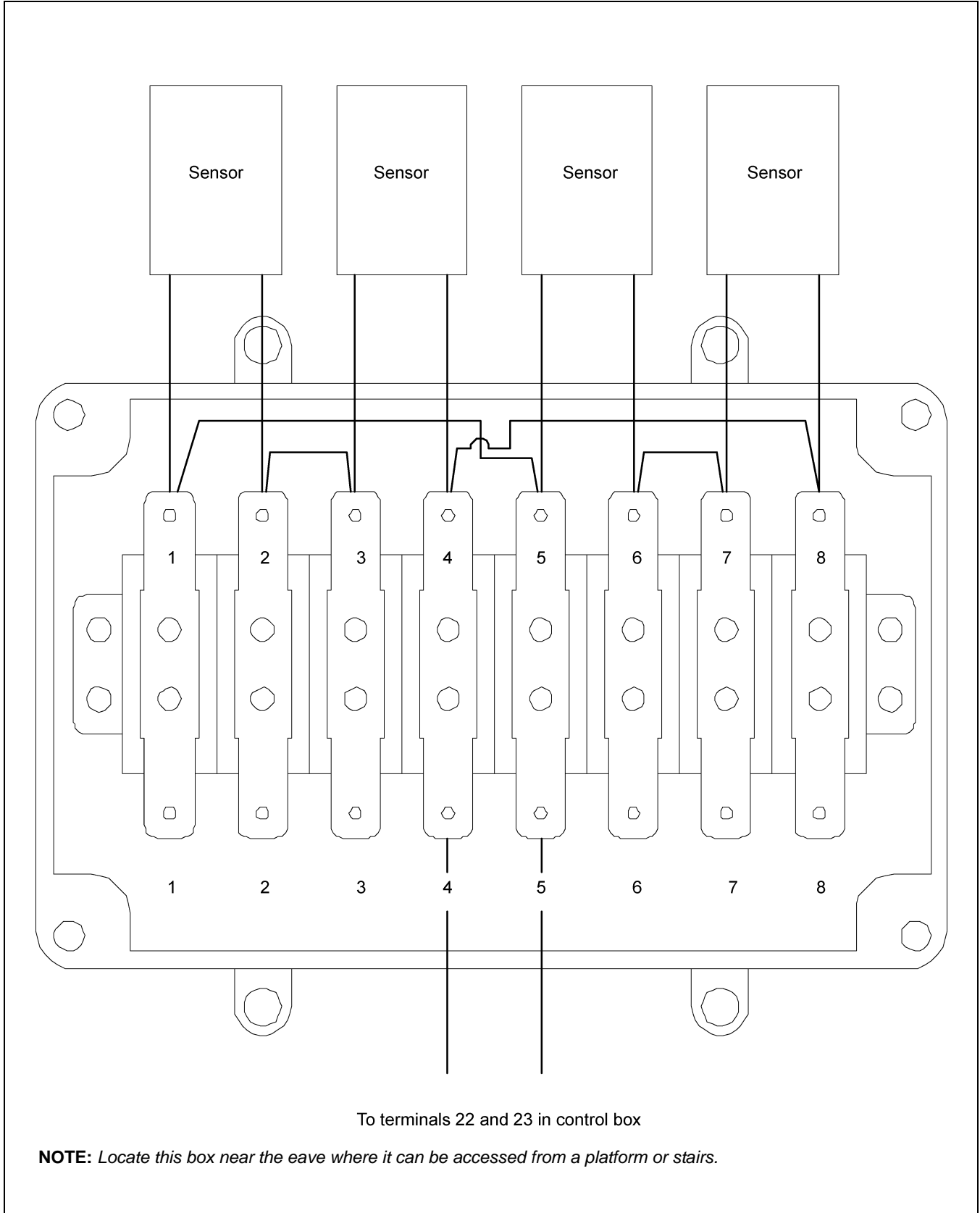

Figure 3J

Grain Temperature Sensor Mounted to Leveling Band Post

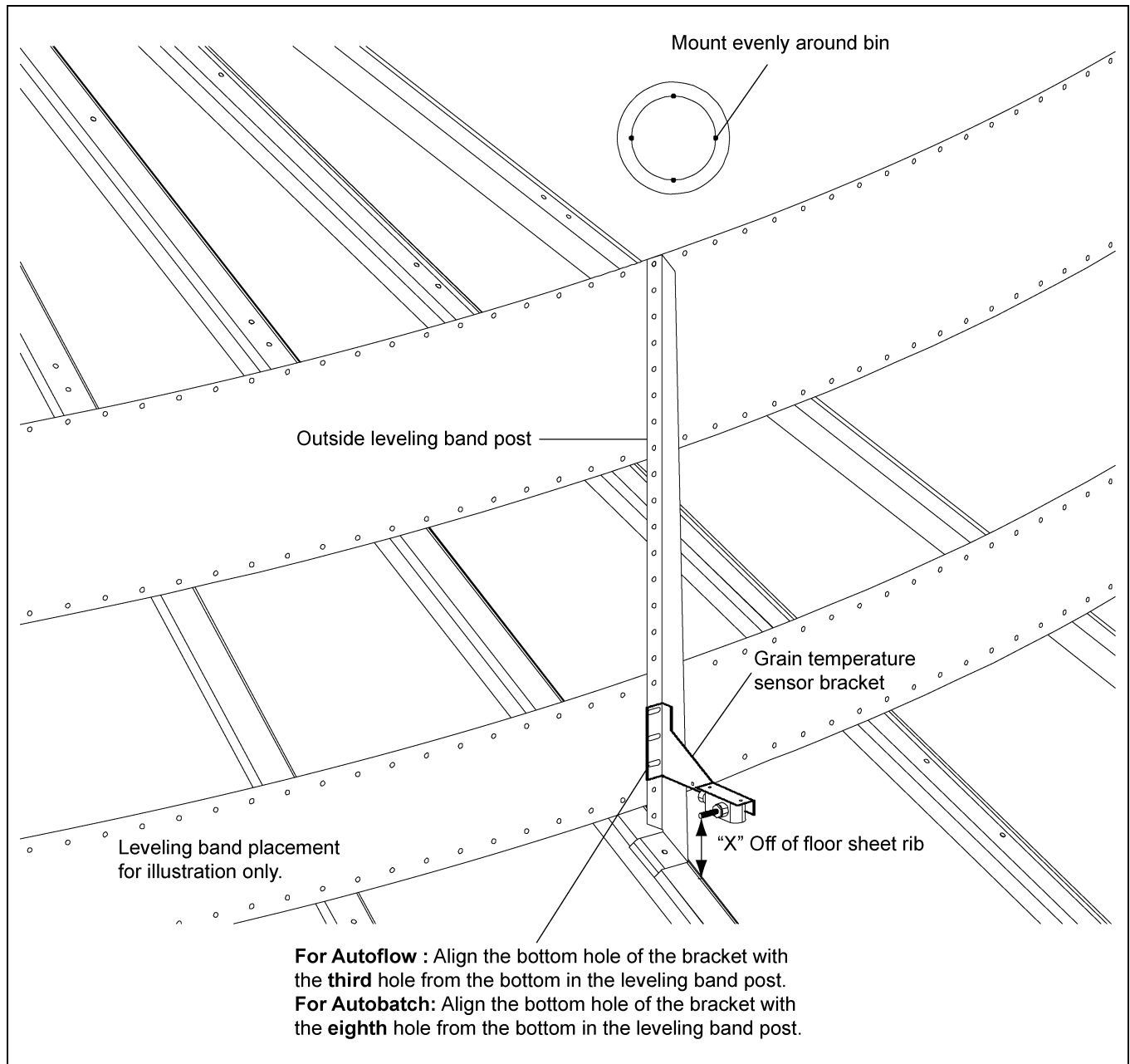

Figure 3K Illustration of grain temperature sensor mounted on outside leveling band post.

Height of Sensor Bracket	
Drying Mode	Approximate Height of "X"
Autoflow	8-1/2"
Autobatch	17-1/2"

NOTE: Prior to 2012, the Autoflow height with the old leveling band positions was 10-1/2".

3. Installation

Plenum Temperature Sensor

The plenum temperature sensor is the small grey PVC junction box attached by a cord to the fan/heater control box on the control fan 1 unit.

1. Locate the sensor to the right of the furthest right fan/heater centered up and down to the duct work entrance. Drill one 3/4" hole even with the duct entrance sheet unit in a valley on the bin sidewall.
2. Insert the probe through the 3/4" hole.
3. Position the housing so the cord exits the housing horizontally and the tabs fall on the sidewall peaks.
4. Use two (2) self-drilling screws to mount the housing to the bin sidewall.
5. Caulk between the housing and the sidewall to seal the gaps.

IMPORTANT: *If the TopDry is a 2 fan unit, do not mount the plenum temperature sensor between the 2 fan/heater units.*

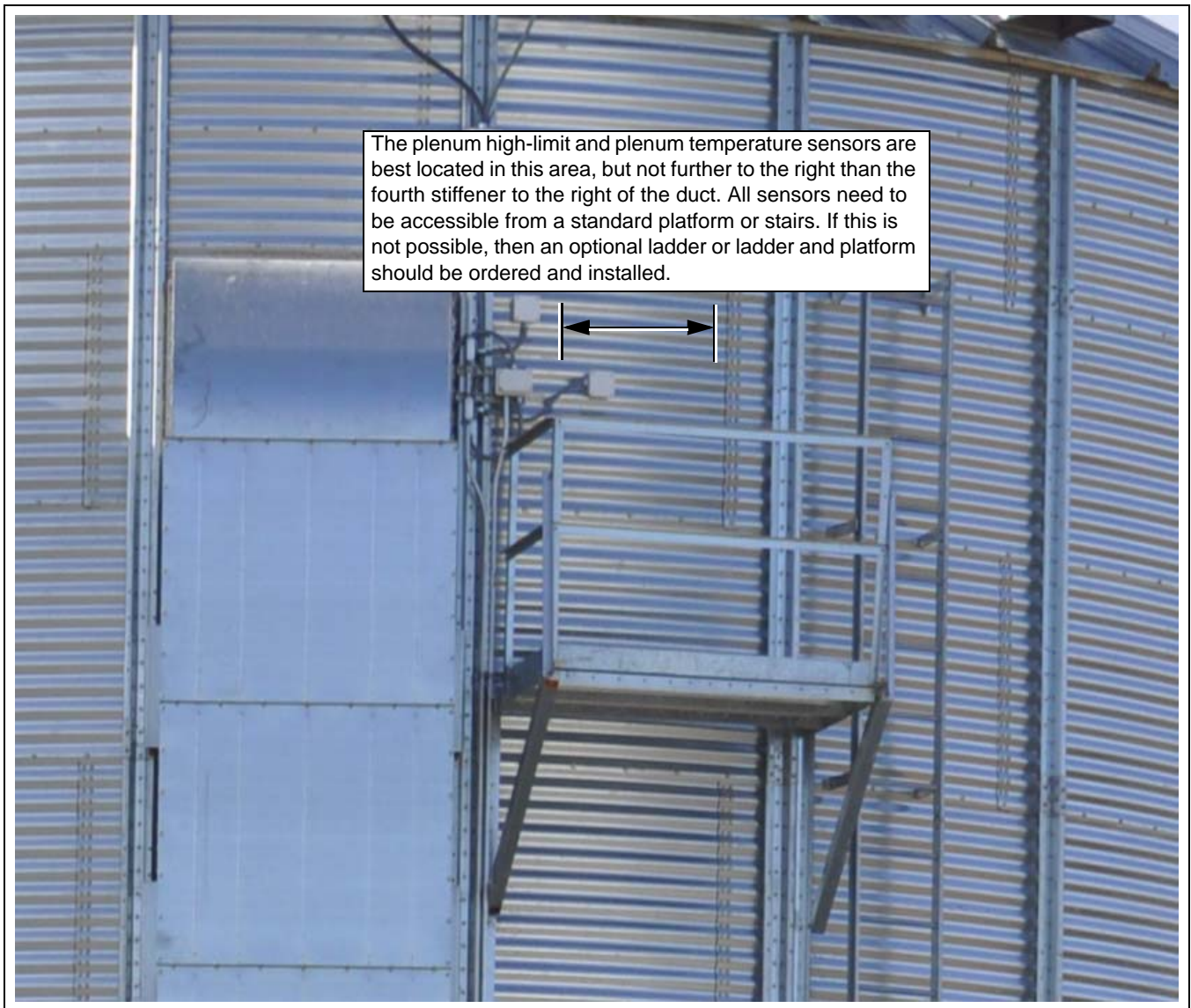

Figure 3L *Optional ladder and platform installed due to the storage chamber door being located elsewhere.*

Plenum Temperature Sensor (Continued)

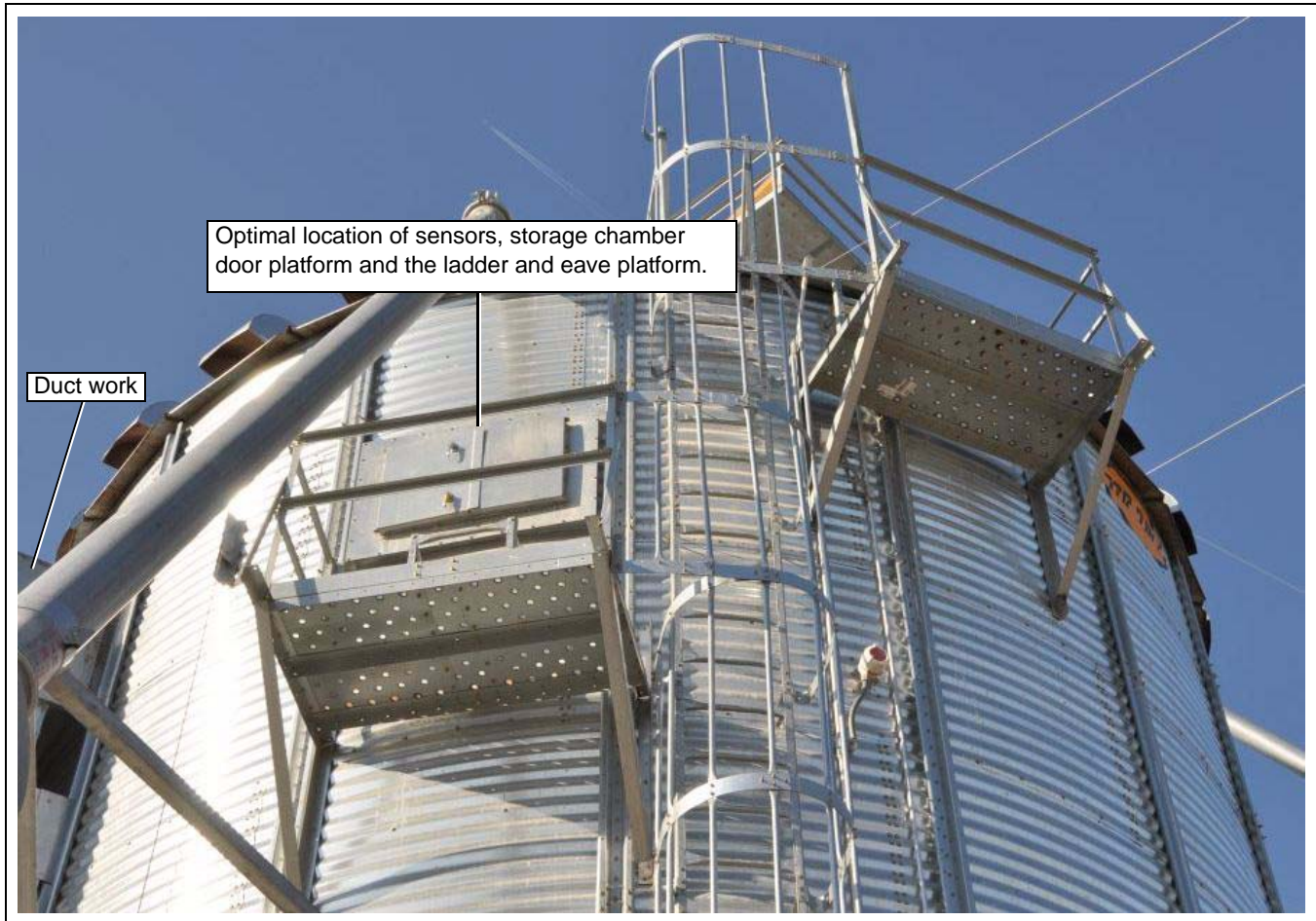

Figure 3M *Standard Storage Chamber Door Platform and Ladder and Eave Platform*

3. Installation

Plenum High-Limit Installation

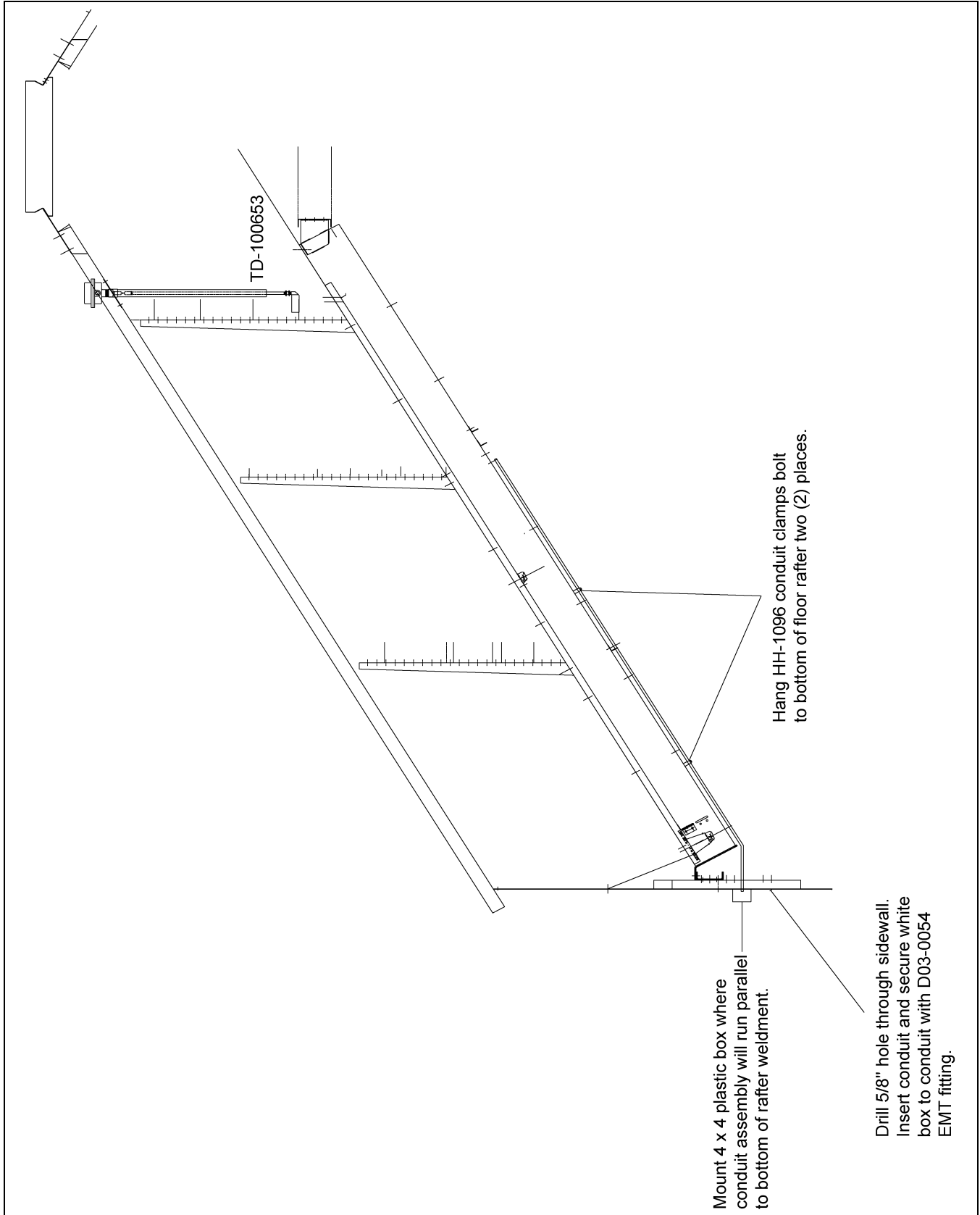

Figure 3N 30' TopDry Layout Plenum High-Limit

TopDry Plenum High-Limit Installation

1. Assemble two (2) pieces of conduit together with coupler.
2. Mount conduit clamps to conduit assembly.
3. Locate conduit assembly on the bottom of a rafter at least 2' to the right of the furthest right fan and heater duct work entrance. Do not install between 2 fan entrances.
4. Mark bin wall where conduit will pass through and drill a hole just large enough to allow the conduit to pass through. Seal hole with caulking when complete.
5. Install white PVC box assembly on outside of bin wall.
6. Insert 10' capillary into conduit assembly.
7. Connect SJO cord to high-limit and connect wires to terminal #20 and terminal #21 on the control fan 1 terminal strip. These terminals are J7-08 and J7-03.

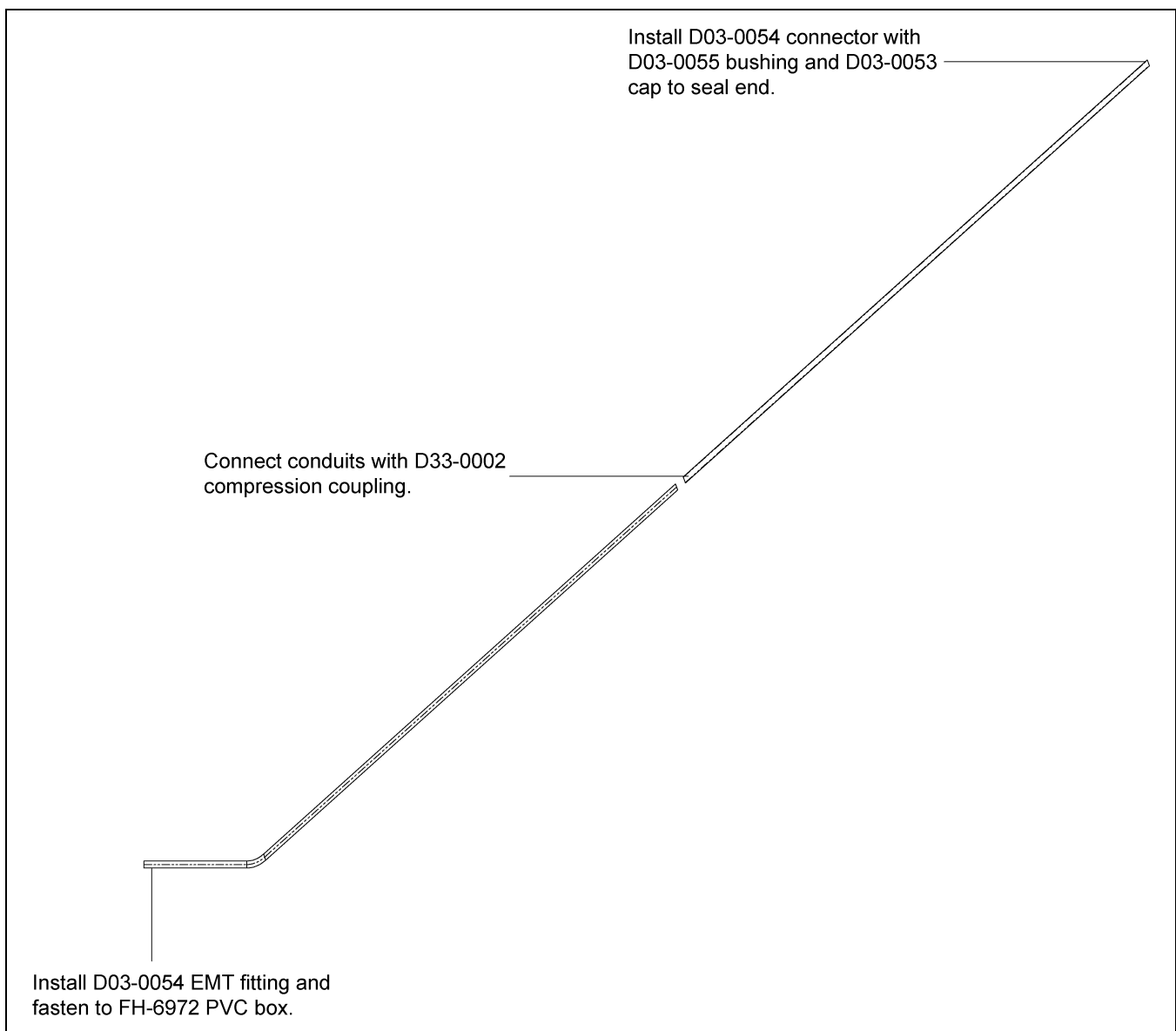

Figure 30

3. Installation

Optional Wet Supply Rotary Switch Installation

It is recommended to use rivet nuts to install the rotary switches for easier service. Use fastenal rivet nut tool #0126106 with knurled nuts and the nose that matches the bolt diameter.

1. Drill a 2" diameter hole through the hopper bottom. If a flat bottom bin is being used for a wet storage tank the Wet Supply Rotary switch would be mounted 45° up the sidewall from the center of the bin. Example: If the wet storage bin is 18' in diameter then the Wet Supply Rotary switch would be mounted 9' up the sidewall.
2. If the bin is 2.66" corrugation, the hole should be centered on an outside hill.
3. If the bin is 4.00" corrugation, the hole should be centered on an outside valley.
4. Use the mounting plate as a pattern and drill four (4) 3/8" holes through the sidewall at the switch location so the plate can be bolted to the bin.
5. Add foam weather strip around the top and side of the mounting plate.
6. Caulk the underside of the mounting plate, on all sides of the 2" hole and where the plate meets the bin.
7. Bolt the mounting plate to the sidewall.
8. Attach the flex coupling to the rotary switch power pack using a roll pin.
9. Attach the 1 vane paddle to the flex coupling as shown in [Figure 3P on Page 31](#).
10. Apply teflon tape or pipe sealant (not included) to the rotary switch power pack threads and thread the rotary switch power pack into the mounting plate coupling.
11. Make sure that the conduit hole is facing down.
12. If the Optional Wet Supply Rotary switch is not use install a jumper between terminals 13 and 14 in the main control box.

Optional Wet Supply Rotary Switch Installation (Continued)

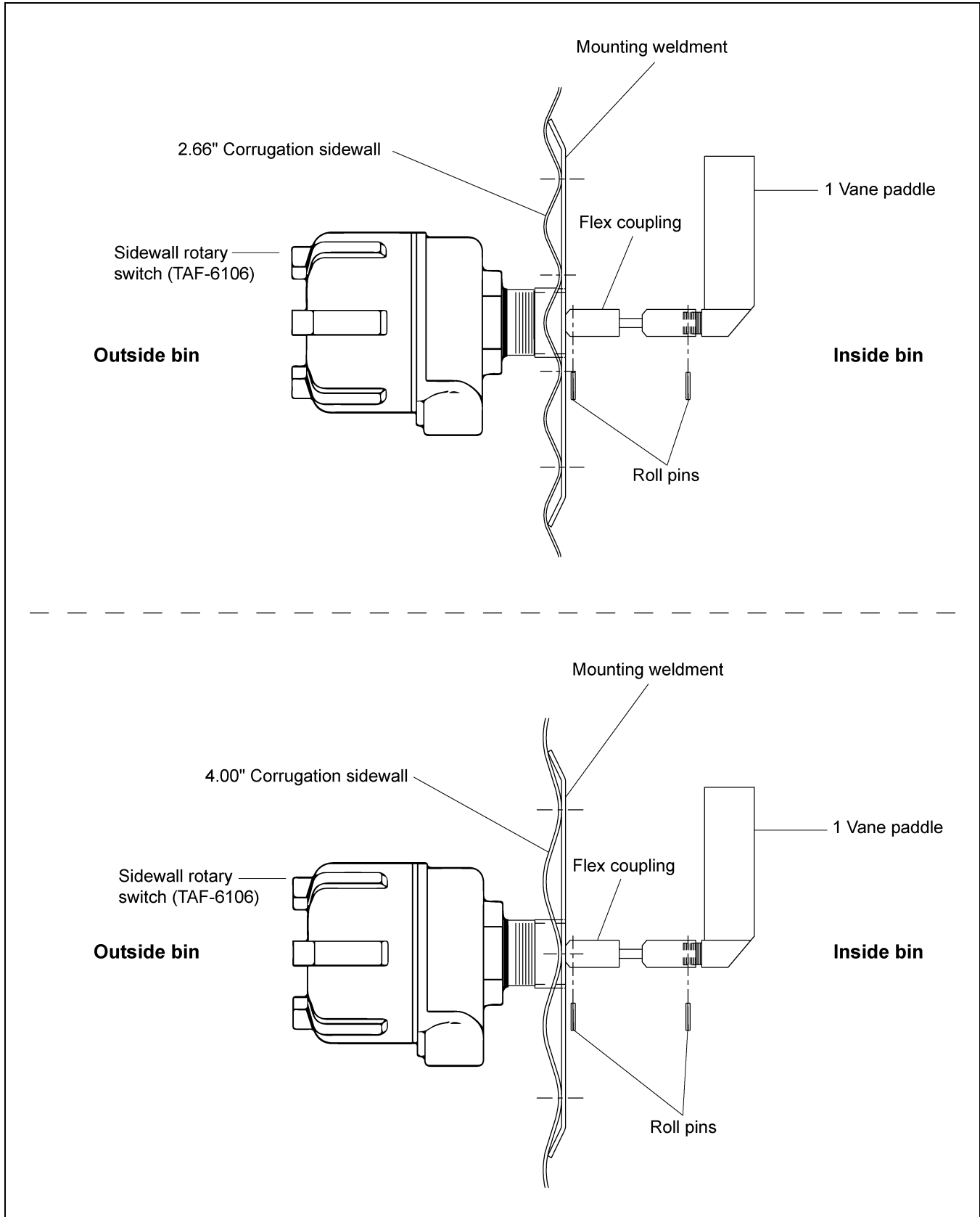

Figure 3P

3. Installation

Storage Chamber High-Limit Rotary Switch Installation

This switch needs to be in close proximity to the duct work, but locating it to the right near the air switch and plenum temperature sensor will allow it to be serviced from the storage chamber platform. If that platform cannot be located here an optional platform and ladder should be considered.

It is recommended to use rivet nuts to install the rotary switches for easier service. Use fastenal rivet nut tool #0126106 with knurled nuts and the nose that matches the bolt diameter.

1. Drill a 2" diameter hole through the sidewall 3' below the fan/heater.
2. If the bin is 2.66" corrugation, the hole should be centered on an outside hill.
3. If the bin is 4.00" corrugation, the hole should be centered on an outside valley.
4. Use the mounting plate as a pattern and drill four (4) 3/8" holes through the sidewall at the switch location so the plate can be bolted to the bin.
5. Add foam weather strip around the top and side of the mounting plate.
6. Caulk the underside of the mounting plate, on all sides of the 2" hole and where the plate meets the bin.
7. Bolt the mounting plate to the sidewall.
8. Attach the flex coupling to the rotary switch power pack using a roll pin.
9. Attach the 1 vane paddle to the flex coupling as shown in [Figure 3R on Page 33](#).
10. Apply teflon tape or pipe sealant (not included) to the rotary switch power pack threads and thread the rotary switch power pack into the mounting plate coupling.
11. Make sure that the conduit hole is facing down.



Figure 3Q *Optional ladder installed due to storage chamber door being located elsewhere.*

Storage Chamber High-Limit Rotary Switch Installation (Continued)

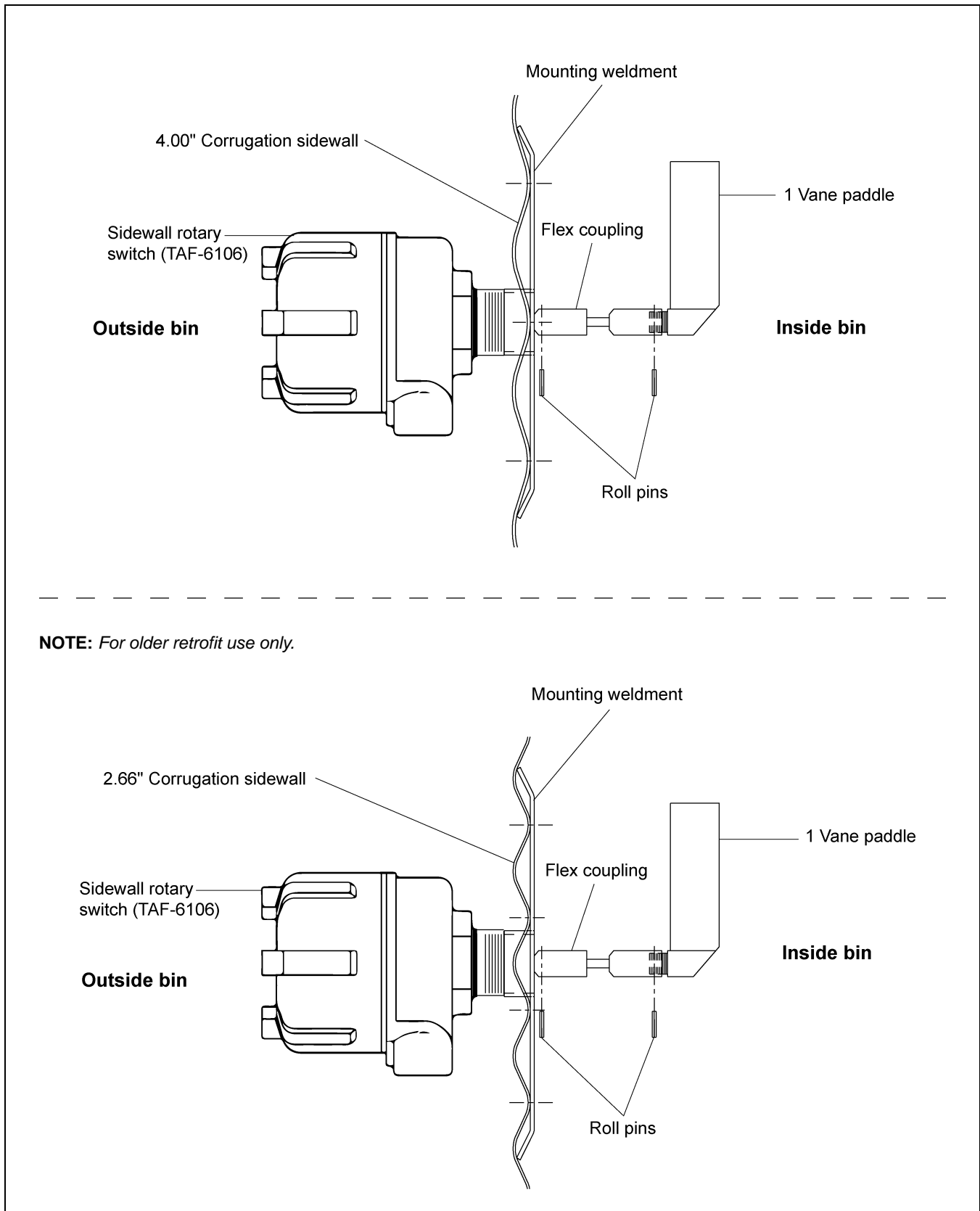

Figure 3R

3. Installation

Drying Chamber Rotary Switches Mounted in Bin Roof

The three (3) Drying Chamber Rotary switches are used by the Series 2000 Autoflow to monitor the location of grain in the drying chamber. The rotary switch with the shortest shaft extension is the Drying Chamber Overflow Rotary switch. It is used as a safety in the event the Chamber High-Level Rotary switch fails. (If a leg with choke fill installation is in use this switch may be omitted.) The rotary switch with the longest extension is the Drying Chamber Low-Level Rotary switch. It is used to inform the computer when the peak has been covered with grain so the drying process can begin; and, will shut down if the drying chamber empties unexpectedly. The third rotary switch is the Drying Chamber High-Level Rotary switch. It is used to inform the dryer when the drying chamber is full so loading can stop. This switch has an adjustable mount so the position can be adjusted to allow it to match the fill rate.

When mounting the Drying Chamber Rotary switches some foresight is needed. The Drying Chamber Rotary switches should be located in close proximity to one another to lessen the amount of conduit and wiring required. The rotary switches should also be mounted so that they are located in an area of the drying chamber that fills evenly with the rest of the drying chamber. The component placement [on Page 17](#) shows the placement of the Drying Chamber Rotary switches in relation to the fill system #1 transport auger/downspout.

The rotary switches should NOT be located in a part of the drying chamber that fills unevenly with the rest of the drying chamber. If the area of the drying chamber where the rotary switches are located fills faster than the rest of the drying chamber the drying chamber will not fill to capacity and uneven drying will result. If the area of the drying chamber where the rotary switches are located fills slower than the rest of the drying chamber an overflow situation may occur.

It is very critical that the drying chamber fill evenly and that the grain falls from fill system #1 directly onto the perforated cone in the drying chamber.

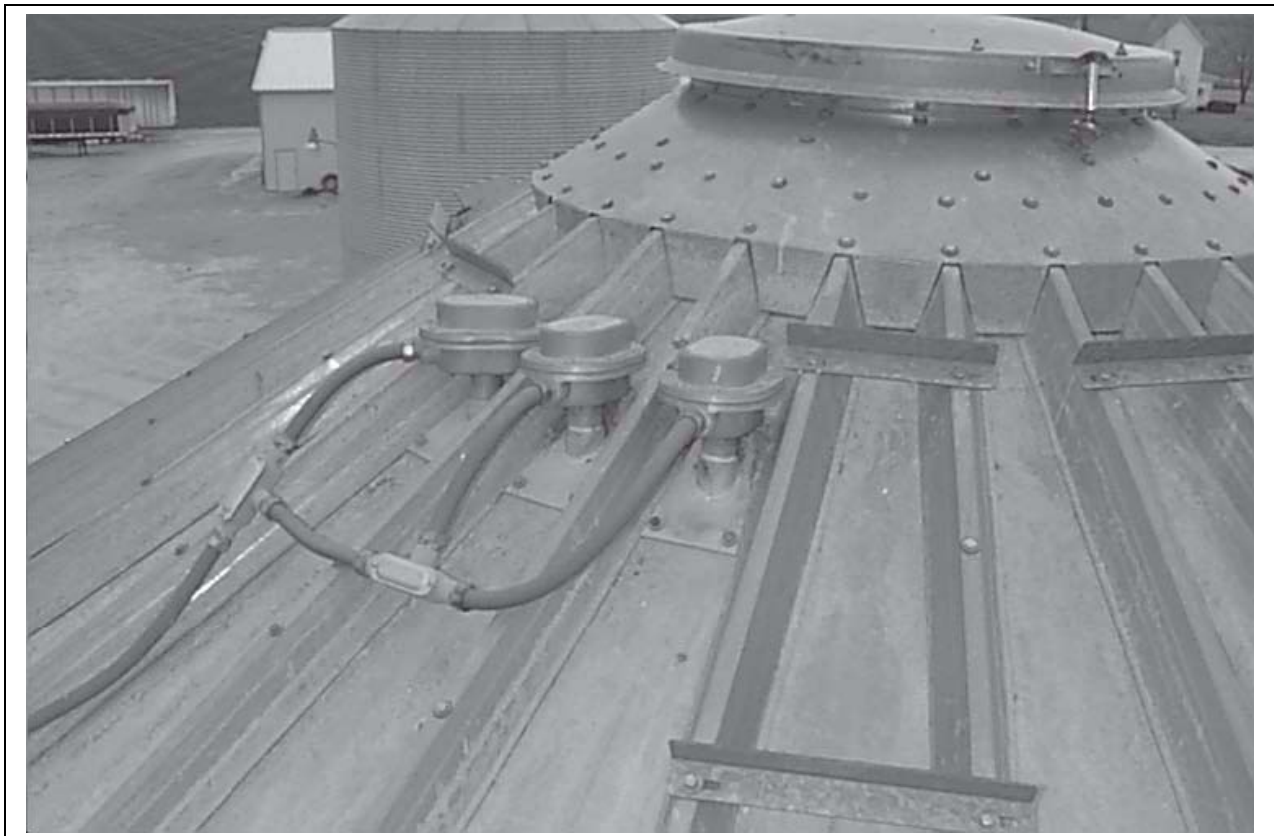

Figure 3S

Drying Chamber Low-Level Rotary Switch Installation

It is recommended to use rivet nuts to install the rotary switches for easier service. Use fastenal rivet nut tool #0126106 with knurled nuts and the nose that matches the bolt diameter.

1. Drill a 2" diameter hole through the roof panel at the location shown in [Figure 3T](#). See component placement [on Page 17](#) for proper placement in relation to fill auger.
2. Use the mounting plate as a pattern and drill four (4) 3/8" holes through the roof panel at the switch location so the plate can be bolted to the roof.
3. Attach the flex coupling to the rotary switch power pack using a roll pin.
4. Apply teflon tape or pipe sealant (not included) to the rotary switch power pack threads and thread the rotary switch power pack into the mounting plate coupling.
5. Make sure that the conduit hole is facing towards the eave.
6. Caulk the underside of the mounting plate and on all sides of the 2" hole.
7. Bolt the assembly to the roof panel.
8. Attach the shaft extension according to [Figure 3U on Page 36](#).
9. Apply teflon tape or pipe sealant (not included) to the shaft guard.
10. Thread to underneath side of mounting plate.
11. Add the 1/4" drilled coupling to the shaft extension using the cotter pin.
12. Attach the 1 vane paddle to the flex coupling as shown in [Figure 3U on Page 36](#).

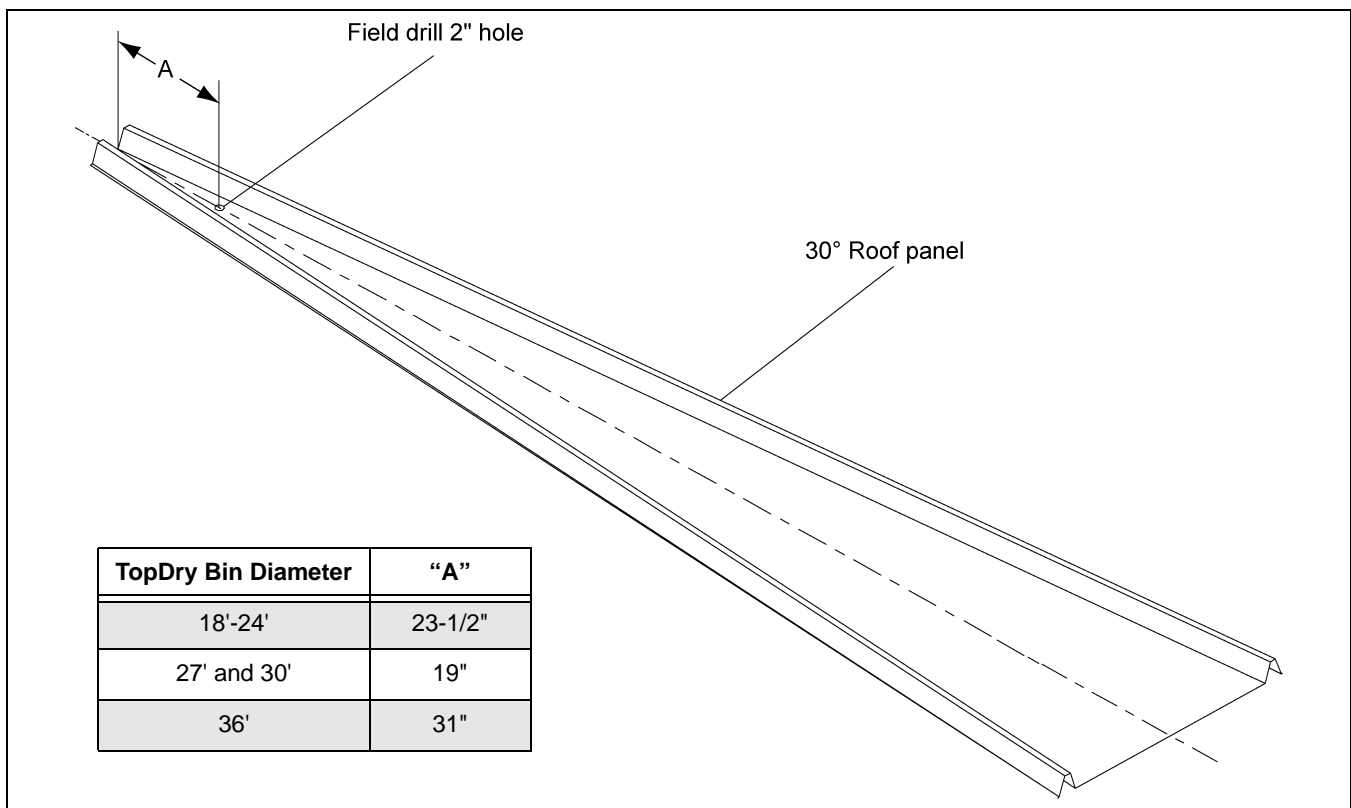

Figure 3T

Drying Chamber Low-Level Rotary Switch Installation (Continued)

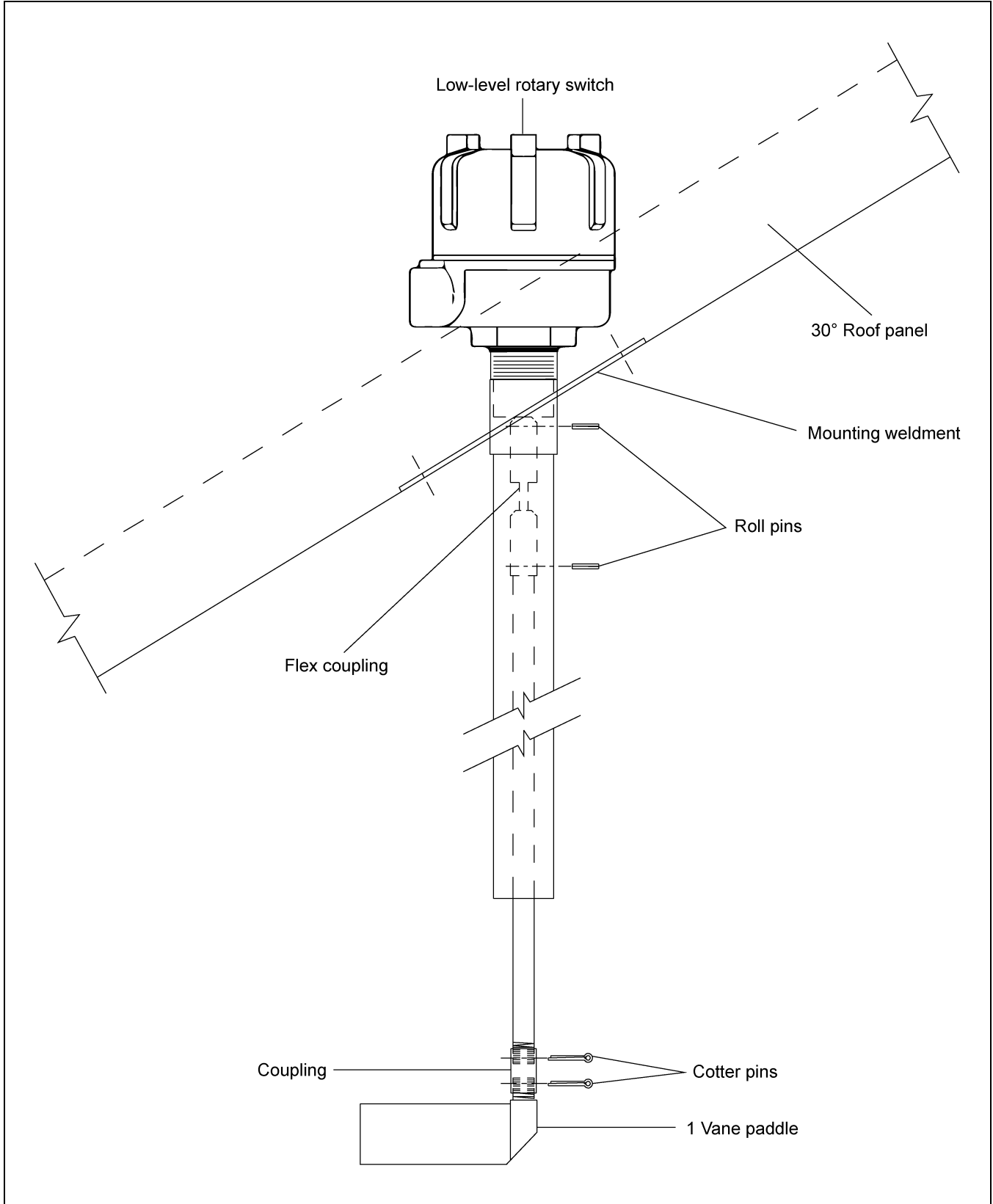

Figure 3U

Drying Chamber High-Level Rotary Switch Installation

NOTE: *If a choke fill load system is used, the Drying Chamber Overflow Rotary switch does not have to be installed and can be jumped at the control box terminals 24 and 25.*

It is recommended to use rivet nuts to install the rotary switches for easier service. Use fastenal rivet nut tool #0126106 with knurled nuts and the nose that matches the bolt diameter.

1. Drill a 2" diameter hole through the roof panel at the location shown in [Figure 3T on Page 35](#). See component placement [on Page 17](#) for proper placement in relation to fill auger.
2. Assemble 1/4" shaft to rotary switch with 1/4" coupler and rolled pins.
3. Screw 1-1/4" pipe coupler to bottom of rotary switch.
4. Insert 1-1/4" pipe through adjustable roof mount weldment. Leave 1-1/4" pipe sticking out the top of the weldment 3" as shown in [Figure 3V](#).
5. Install switch assembly through 2" hole in roof.
6. Install paddle to 1/4" shaft assembly with coupler and rolled pins.

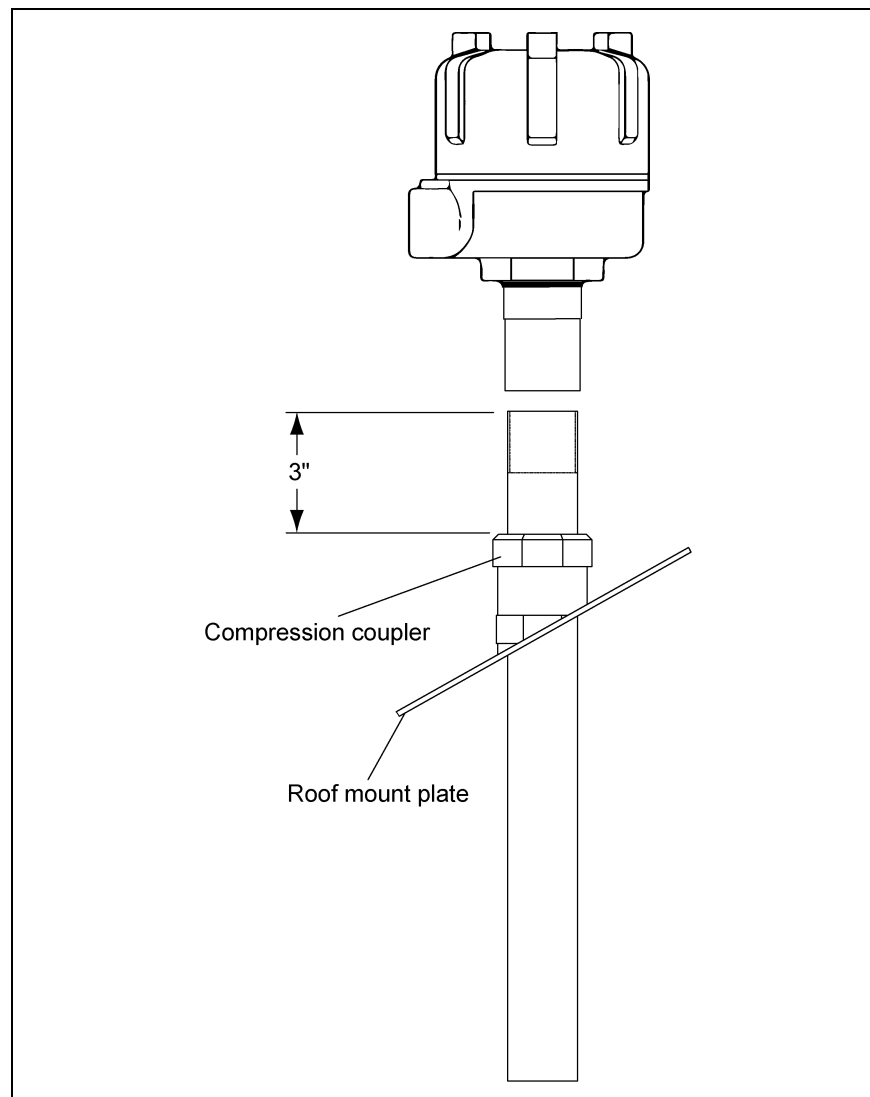

Figure 3V

3. Installation

Drying Chamber Overflow Rotary Switch Installation

It is recommended to use rivet nuts to install the rotary switches for easier service. Use fastenal rivet nut tool #0126106 with knurled nuts and the nose that matches the bolt diameter.

1. Drill a 2" diameter hole through the roof panel at the location shown in [Figure 3T on Page 35](#). See component placement [on Page 17](#) for proper placement in relation to fill auger.
2. Use the mounting plate as a pattern and drill four (4) 3/8" holes through the roof panel at the switch location so the plate can be bolted to the roof.
3. Attach the flex coupling to the rotary switch power pack using a roll pin.
4. Apply teflon tape or pipe sealant (not included) to the rotary switch power pack threads and thread the rotary switch power pack into the mounting plate coupling.
5. Make sure that the conduit hole is facing towards the eave.
6. Caulk the underside of the mounting plate and on all sides of the 2" hole.
7. Bolt the assembly to the roof panel.
8. Attach the 3 vane paddle to the flex coupling as shown in [Figure 3W](#).

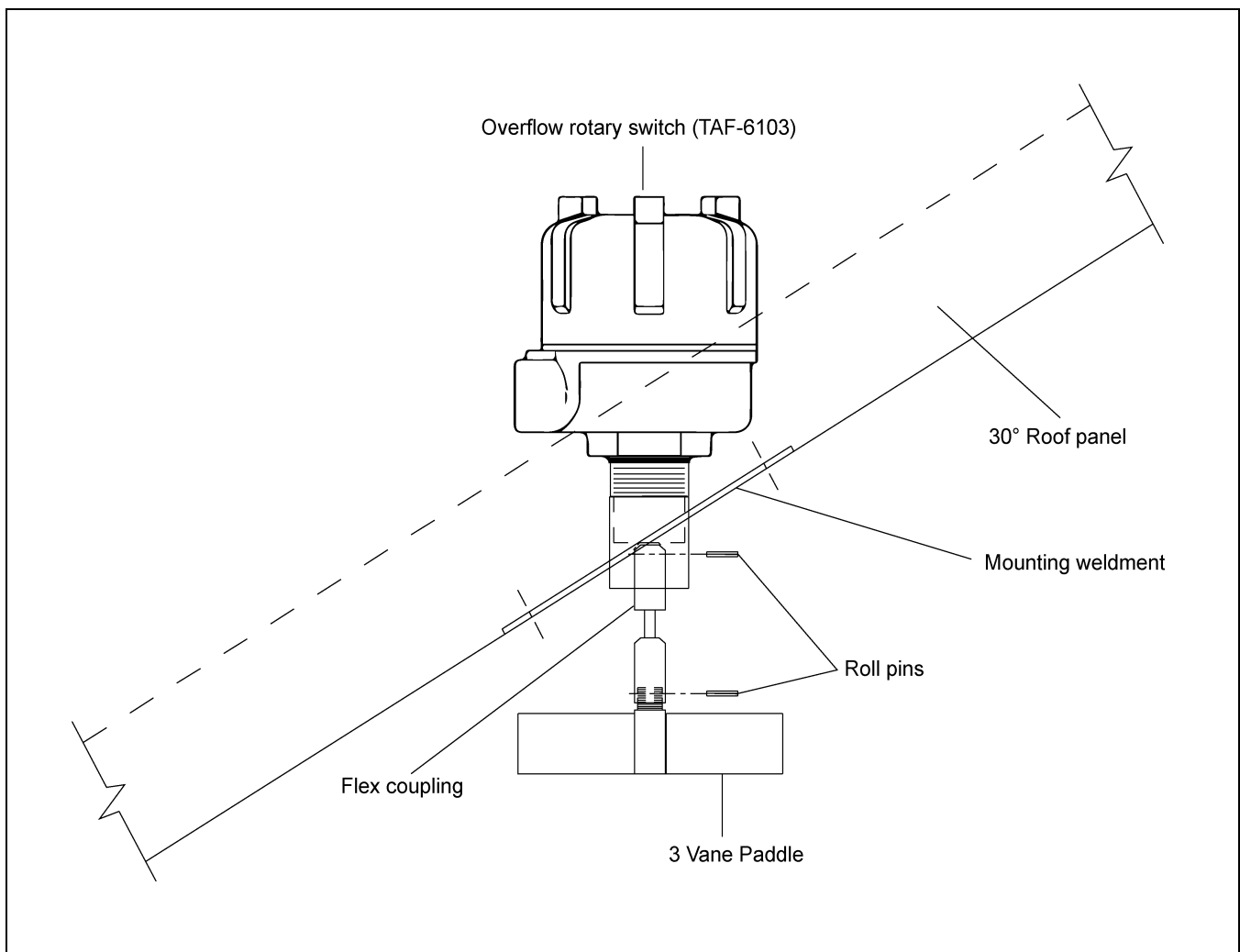

Figure 3W

Liquid Propane (LP)

TopDry dryers have internal vaporizers and are designed to operate on liquid draw from the supply tank. Avoid using propane supply tanks that have been used for vapor draw for long periods of time. When using liquid draw systems, any moisture that may be present in tanks or lines may freeze when the system is used in cold weather. To avoid this situation, purge the system with methanol.

NOTICE

Do not use tanks which have previously been used for ammonia or fertilizer solutions. These substances are extremely corrosive and will damage fuel supply and burner parts.

Because the vaporizer coil may need to be adjusted during operation flexible hose suitable for LPs should be used for the final field connection.

See the *below* "Fuel Systems and Recommendations Chart" for liquid propane (LP) to determine the correct size line to run from the tank to the dryer. Have a qualified gas service person inspect the installation to be sure that everything is installed according to local codes and ordinances.

After installation is complete, check all connections for leaks with liquid detergent or comparable. Wear rubber gloves and eye protection. Avoid contact with liquid propane.



Do not use flame for leak testing.

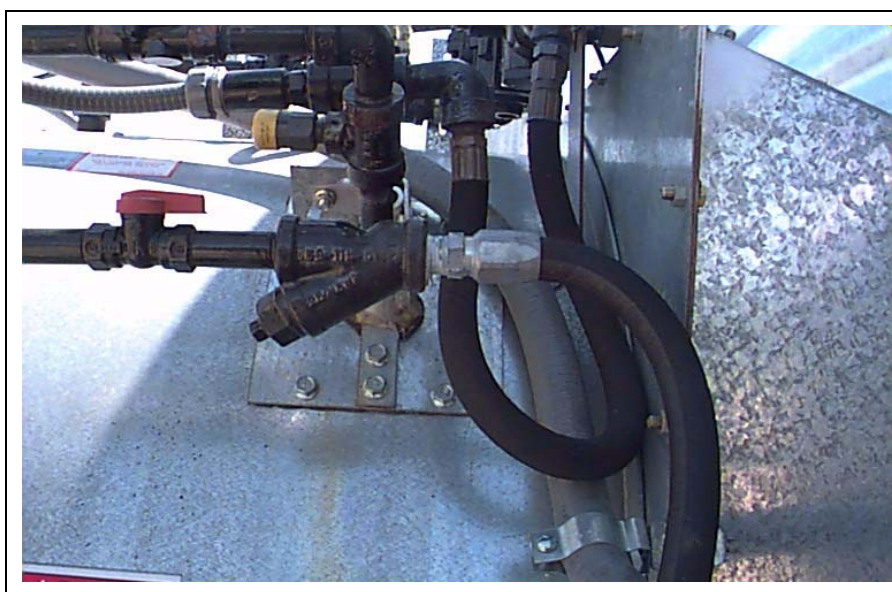

Figure 3X LP Line Field Connection

Fuel System Specifications and Recommendations Liquid Propane (LP)

Dryer Fan Size	Dryer Horsepower	Maximum Heat Capacity BTU per Hour	Maximum Fuel Flow Gallons per Hour	Minimum Line Size	Orifice Size	Minimum Operating Pressure	Maximum Operating Pressure
36"	15	4.5 Million	49	1/2"	21/64"	2 lbs.	14 lbs.
40"	15	5.75 Million	63	1/2"	11/32"	2 lbs.	18 lbs.
42"	30	8.75 Million	95	1/2"	7/16"	2 lbs.	16 lbs.
42"	40	10.25 Million	112	3/4"	29/64"	2 lbs.	20 lbs.

3. Installation

Natural Gas (NG)

This dryer is designed to operate on natural gas. Natural gas units have a larger orifice to accommodate lower pressures sometimes found with natural gas and do not have vaporizer coils like liquid propane units. A regulated pressure of 10 PSI minimum, 30 PSI maximum must be provided at the field connection point on the fan/heater unit, with gas available in sufficient volume to maintain the operating pressure.

See the [below](#) "Fuel Systems and Recommendations Chart" for natural gas (NG) to determine the correct size line to run to the dryer. Have a qualified gas service person inspect the installation to be sure everything is installed according to local codes and ordinances.

After installation is complete, check all connections for leaks with liquid detergent or comparable. Wear rubber gloves and eye protection.



Do not use flame for leak testing.

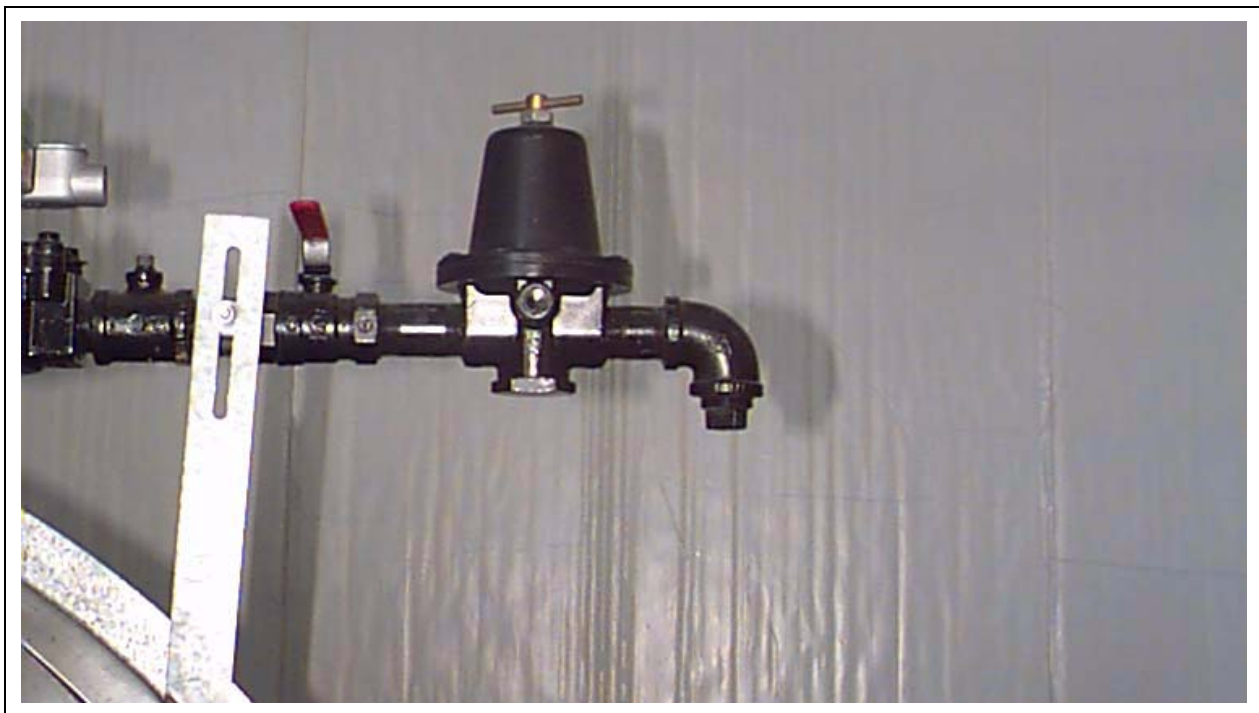

Figure 3Y NG Line Field Connection

Fuel System Specifications and Recommendations Natural Gas (NG)

Dryer Fan Size	Dryer Horsepower	Maximum Heat Capacity BTU per Hour	Maximum Fuel Flow Cubic Ft. per Hour	Minimum Line Size	Orifice Size	Minimum Operating Pressure	Maximum Operating Pressure
36"	15	4.5 Million	4500	2"	27/64"	2 lbs.	12 lbs.
40"	15	5.75 Million	5750	2"	33/64"	2 lbs.	9 lbs.
42"	30	8.75 Million	8750	2"	19/32"	2 lbs.	12 lbs.
42"	40	10.25 Million	10250	2"	23/32"	2 lbs.	7.5 lbs.

Conduit Runs

Never run control wiring together with motor wires, high amperage wires or wires with voltage over 120 volts.

Control Wires

Run #1 Autoflow control box to control fan 1 control box.

Five (5) - Control wires 16 gauge minimum. (**NOTE:** A shielded two (2) conductor 16 gauge cable should be used for the network connections.)

Run #2 Autoflow control box to chute control box.

Six (6) - Control wires 16 gauge minimum. Six (6) if the new chute controller is in use.

Run #3 Optional: Autoflow control box to Wet Supply Rotary switch (if applicable).

Four (4) - Control wires 16 gauge minimum.

Run #4 Autoflow control box to Storage Chamber Rotary switch.

Five (5) - Control wires 16 gauge minimum.

Run #5 Autoflow control box to Drying Chamber Rotary switches.

Six (6) - Control wires 16 gauge minimum.

Run #6 Autoflow control box to fill system control box (if applicable).

Eleven (11) - Control wires 16 gauge minimum.

Run #7 Control fan 1 control box to fan 2 control box.

Four (4) - Control wires 16 gauge minimum. (**NOTE:** A shielded two (2) conductor 16 gauge cable should be used for the network connections.)

Run #8 Fan 2 control box to fan 3 control box.

Four (4) - Control wires 16 gauge minimum. (**NOTE:** A shielded two (2) conductor 16 gauge cable should be used for the network connections.)

Power/Motor Wires

Run #1 Entrance panel to control fan 1 control box (for fan motor).

Run #2 Entrance panel to fan 2 control boxes (if applicable, for fan motor).

Run #3 Entrance panel to fill system control box (if applicable).

1. For fill system #1 motor starter.
2. For fill system #2 motor starter (if applicable).
3. For aeration fan motor starter.

Run #4 Fill system control box to fill system #1 motor.

Run #5 Fill system control box to fill system #2 motor (if applicable).

Run #6 Fill system control box to aeration fan motor.

Run #7 Entrance panel to actuator control box.

4. Electrical Power Supply

Grounding

All control boxes should be properly grounded with a ground lug mounted in each control box.

Power Supply

An adequate power supply and proper wiring are important factors to achieve maximum performance and long life of the dryer. Electrical service must be adequate enough to prevent low voltage damage to motors and control circuits. (See electrical load information [on Page 44.](#))

Transformer and Wiring Voltage Drop

It is necessary to know the distance from the unit to the available transformer and the horsepower of the fan unit. Advise the service representative of your local power supplier that an additional load will be placed on the line. Each fan motor should be wired through a fused or circuit breaker disconnect switch. Check on KVA rating of transformers, considering total horsepower load. The power supply wiring, main switch equipment and transformers must provide adequate motor starting and operating voltage. Voltage drop during motor starting should not exceed 14% of normal voltage and after motor is running at full speed it should be within 8% of normal voltage. Check electrical load information [on Page 44](#) for HP ratings and maximum amp loads to properly size wire and fusing elements. Standard electrical safety practices and codes should be used. (Refer to National Electrical Code Standard Handbook by National Fire Protection Association.)

Machine to Earth Grounding

It is very important that a *machine to earth ground rod* be installed at the fan. This is true even if there is a ground at the pole 15' away. Place the ground rod that comes standard, within 8' of the dryer and attach it to the dryer control panel with at least a #6 solid, bare, copper ground wire and the clamp provided. The grounding rod located at the power pole will not provide adequate grounding for the dryer. The proper grounding will provide additional safety in case of any short and will ensure long life of all circuit boards and the ignition system. The ground rod must be in accordance with local requirements.

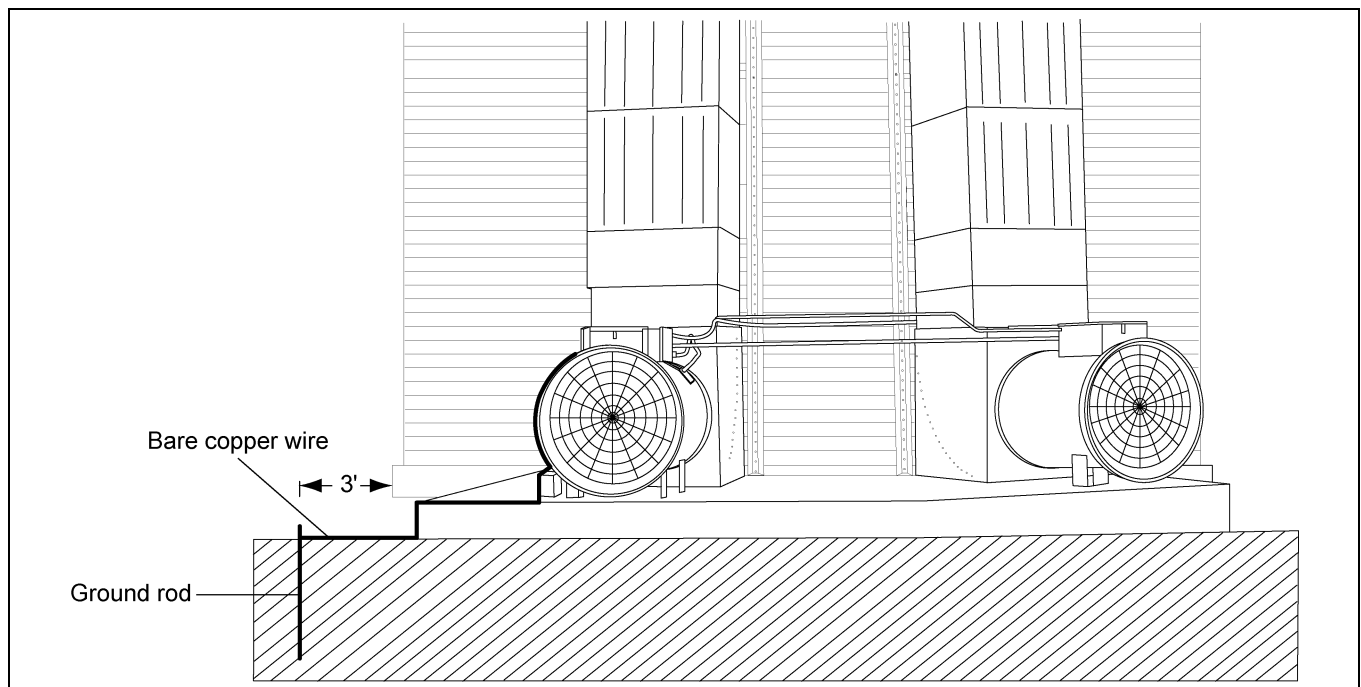

Figure 4A *The TopDry and Ground Rod Attachment Illustration*

Power/Motor Wiring

The *Figure 4B* details the configuration for correct main power installation. Use the diagram in conjunction with the electrical load information and wire size information provided. The diagram details the correct main power installation for 220V 1 PH, 230V 3 PH, 460V 3 PH, 575V 3 PH and 380V 3 PH 50 Hz power supplies.

On all 3 phase systems put the leg with the highest potential difference between that leg and ground (wild or high voltage leg) on the center terminal (L2) at the motor starter.

NOTICE *Standard electrical safety procedures should be used. (Refer to the National Electrical Code Standard Handbook by the National Fire Protection Association.) A qualified electrician should make all electrical wiring installations. Follow all local or national electrical safety standards and ordinances when installing the equipment.*

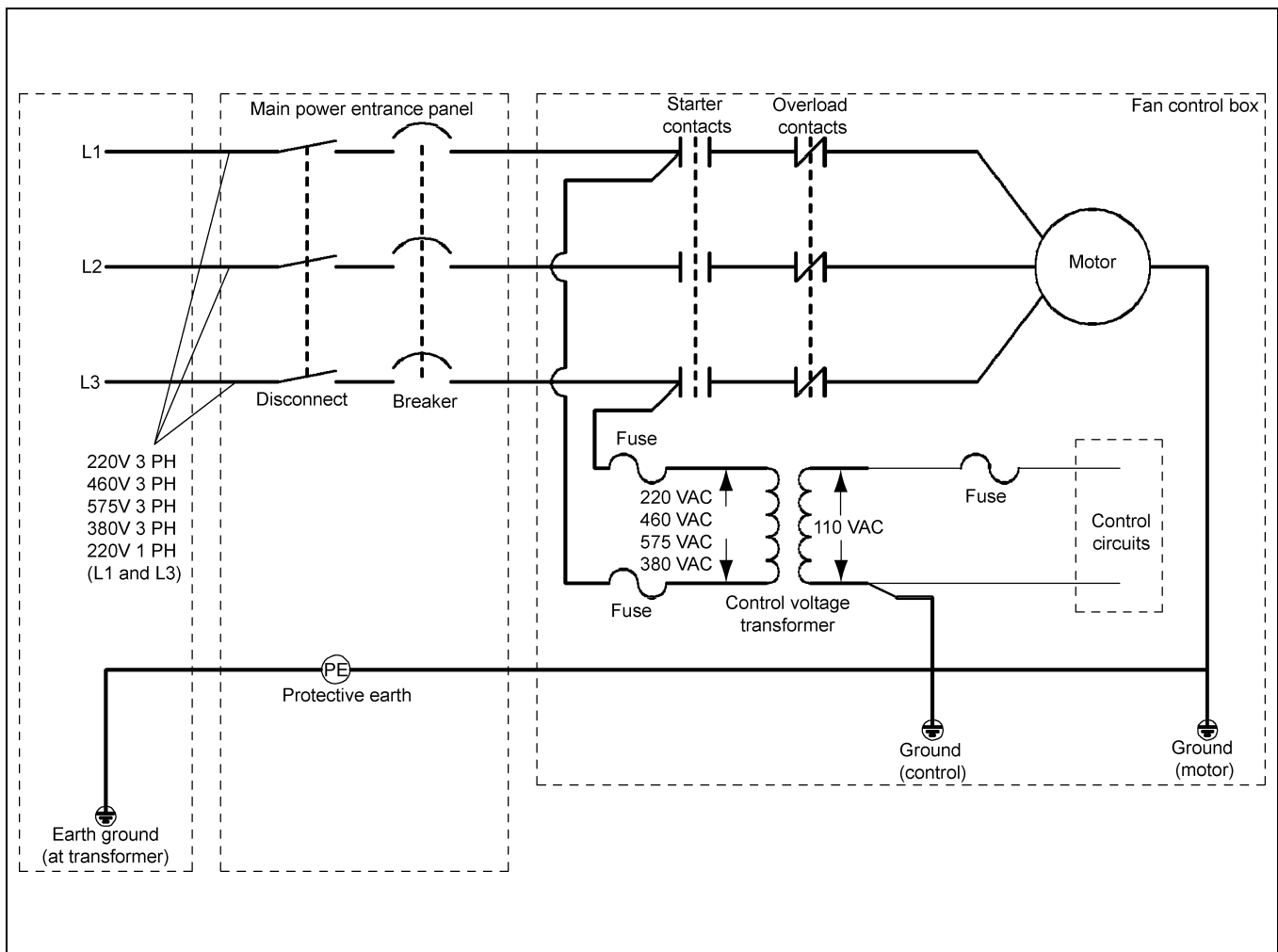

Figure 4B Main Power Schematic

4. Electrical Power Supply

Electrical Load Information

The [Chart below](#) provide information for the electrician wiring the grain dryer and are a reference guide for parts. It is recommended that you contact your local power company and have a representatives survey the installation to see that the wiring is compatible with their system and that adequate power is supplied to the unit.

NOTE: *The only thing connected to the recommended service amps should be the grain dryer. Standard electrical safety procedures should be used. (Refer to the National Electrical Code Standard Handbook by the National Fire Protection Association.) A qualified electrician should make all electrical wiring installations.*

Dryer Fan Size	Voltage	Horsepower	Full Load Amps	Fuse (Slow Blow)	Breaker
36"	220V 1 PH	15	78	150	150
	208V 3 PH	15	44	125	125
	220V 3 PH	15	39	100	100
	380V 50 Hz	15	27	80	80
	460V 3 PH	15	20	50	50
	575V 3 PH	15	16	40	40
40"	220V 1 PH	15	78	150	150
	208V 3 PH	15	44	125	125
	220V 3 PH	15	39	100	100
	380V 50 Hz	15	27	80	80
	460V 3 PH	15	20	50	50
	575V 3 PH	15	16	40	40
42"	208V 3 PH	30	80	150	150
	220V 3 PH	30	74	150	150
	380V 50 Hz	30	39	100	100
	460V 3 PH	30	37	100	100
	575V 3 PH	30	30	80	80
42"	208V 3 PH	40	108	200	200
	220V 3 PH	40	102	200	200
	380V 50 Hz	40	47	100	100
	460V 3 PH	40	51	100	100
	575V 3 PH	40	40	100	100

Electrical Load Information (Continued)

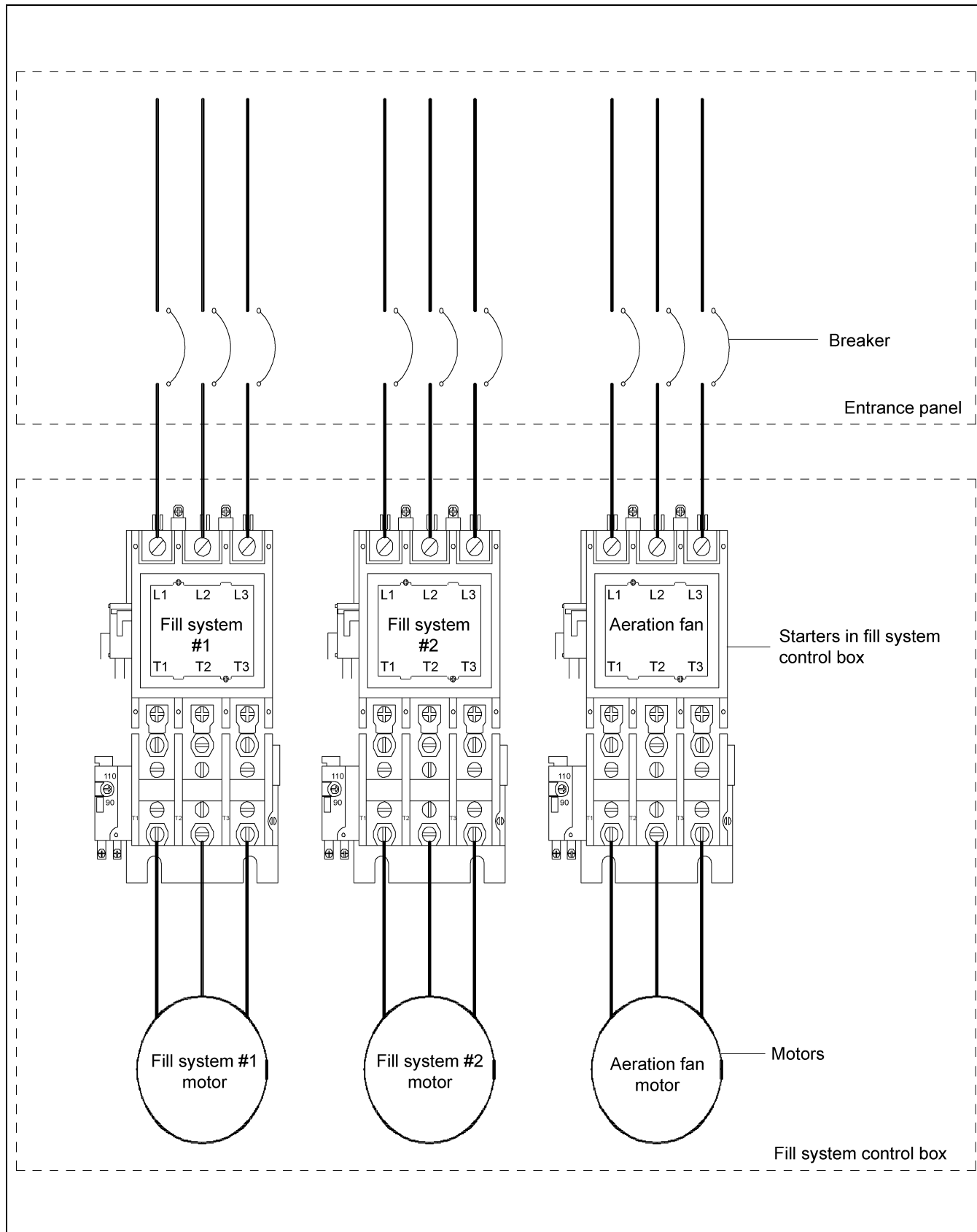

Figure 4C

4. Electrical Power Supply

Connect Autoflow to Control Fan 1

The control fan 1 unit is the only fan and heater in a single fan unit. In two (2) fan units it is the fan/heater with the air switch, plenum temperature sensor and grain temperature sensor connected to it. DO NOT run the control wires for the control fan 1 in the same conduit as the power wires for the fan motor. To wire the control fan 1 unit to the Autoflow control box do the following.

NOTE: Do NOT use solid wire for interconnections.

NOTE: The control fan 1 is always located on the right and has a step down transformer.

NOTE: A shielded 16 gauge cable is recommended for use on the network connection. The network wires for this configuration are attached to terminal #4 and terminal #5. Ground each end of the shielded cable to the housing. A shielded 16 gauge 2 wire cable can be purchased from GSI. Part #WR-16/2S.

1. Run five (5) control wires from the Autoflow control box to the control fan 1 unit.
2. Connect the wires as shown in [Figure 4D](#).

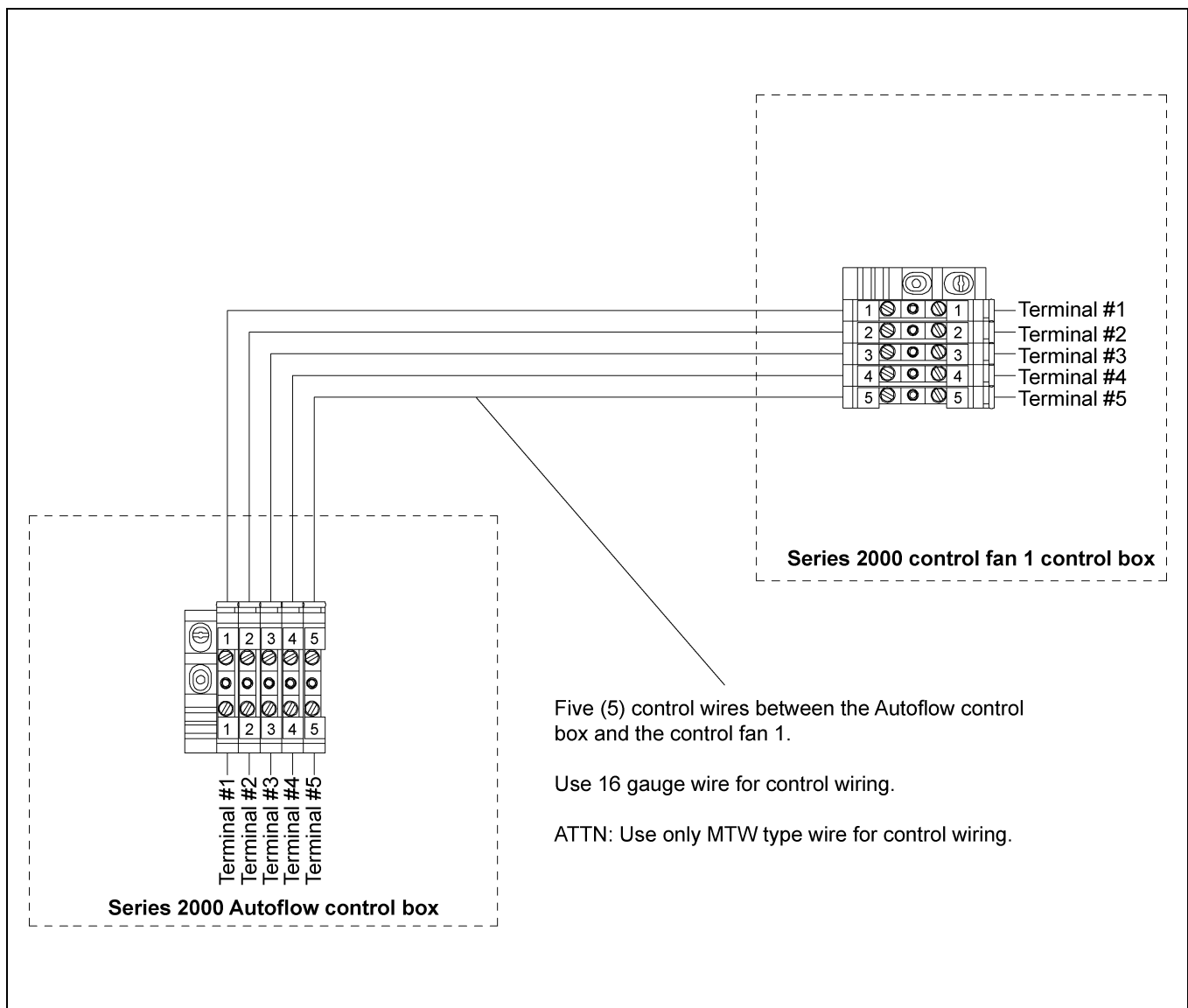

Figure 4D Control Fan 1 Dip Switch Setting: #1 - "OFF"/All Others - "ON"

Control Fan 1 to Fan 2 Interconnect

A fan 2 unit can be added to operate in unison with the control fan 1 unit. The interconnect between the control fan 1 and fan 2 units remains the same regardless of the type or presence of a control center. To wire a fan 2 unit to a control fan 1 unit do the following:

NOTE: Do not use solid wire for interconnection or run control wires with motor wires, high amperage wires or voltage wires above 120 volts.

1. Run four (4) 16 gauge MTW type wires from the control fan 1 unit to the fan 2 unit.
2. Connect the wires as shown in [Figure 4E](#).

NOTE: A shielded 16 gauge cable is recommended for use on the network connections. The network connections for this configuration are attached to terminal #8 and terminal #9 in the control fan 1 unit and terminal #3 and terminal #4 in the fan 2 unit. Ground each end of the shielded cable to the housing. A shielded 16 gauge 2 wire cable can be purchased from GSI. Part #WR-16/2S.

Fan #2 and Heater Dip Switch Setting: #2 - “OFF”/All Others - “ON”

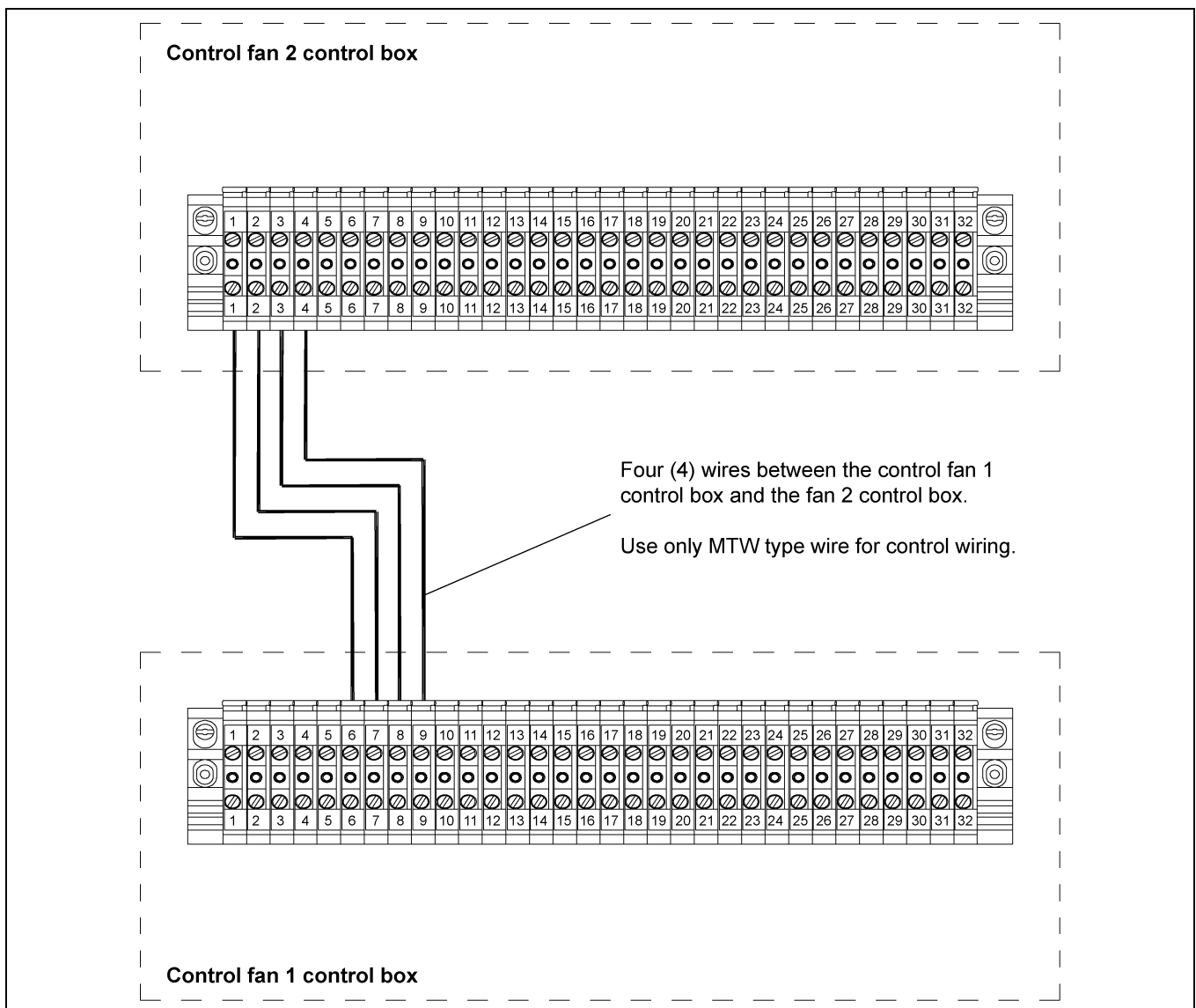

Figure 4E Wiring for a Fan 2 Unit to a Control Fan 1 Unit

4. Electrical Power Supply

Autoflow to Actuator Interconnect

NOTE: A new Chute Controller started shipping in late 2012 that does not use batteries. It can be retrofitted with the addition of one wire from the control box to the new controller. There is a separate Installation Manual PNEG-1894 which includes the wiring changes available for the new Chute Controller.

The actuator control box houses the 24V DC linear actuator, two (2) 12V DC batteries and a 24V DC battery charger. The linear actuator raises and lowers the dump chutes to unload grain automatically from the drying chamber to the storage chamber. The two (2) 12V DC batteries act as a back-up to prevent wet grain from dumping into the storage chamber during a power outage. The 24V DC battery charger provides a continuous recharge to the batteries.

To wire the actuator control box to the Autoflow control box do the following.

1. Run five (5) control wires from the Autoflow control box to the actuator control box.
2. Run three (3) power wires from the entrance panel to the actuator control box.
3. Connect the wires as shown in [Figure 4F](#).

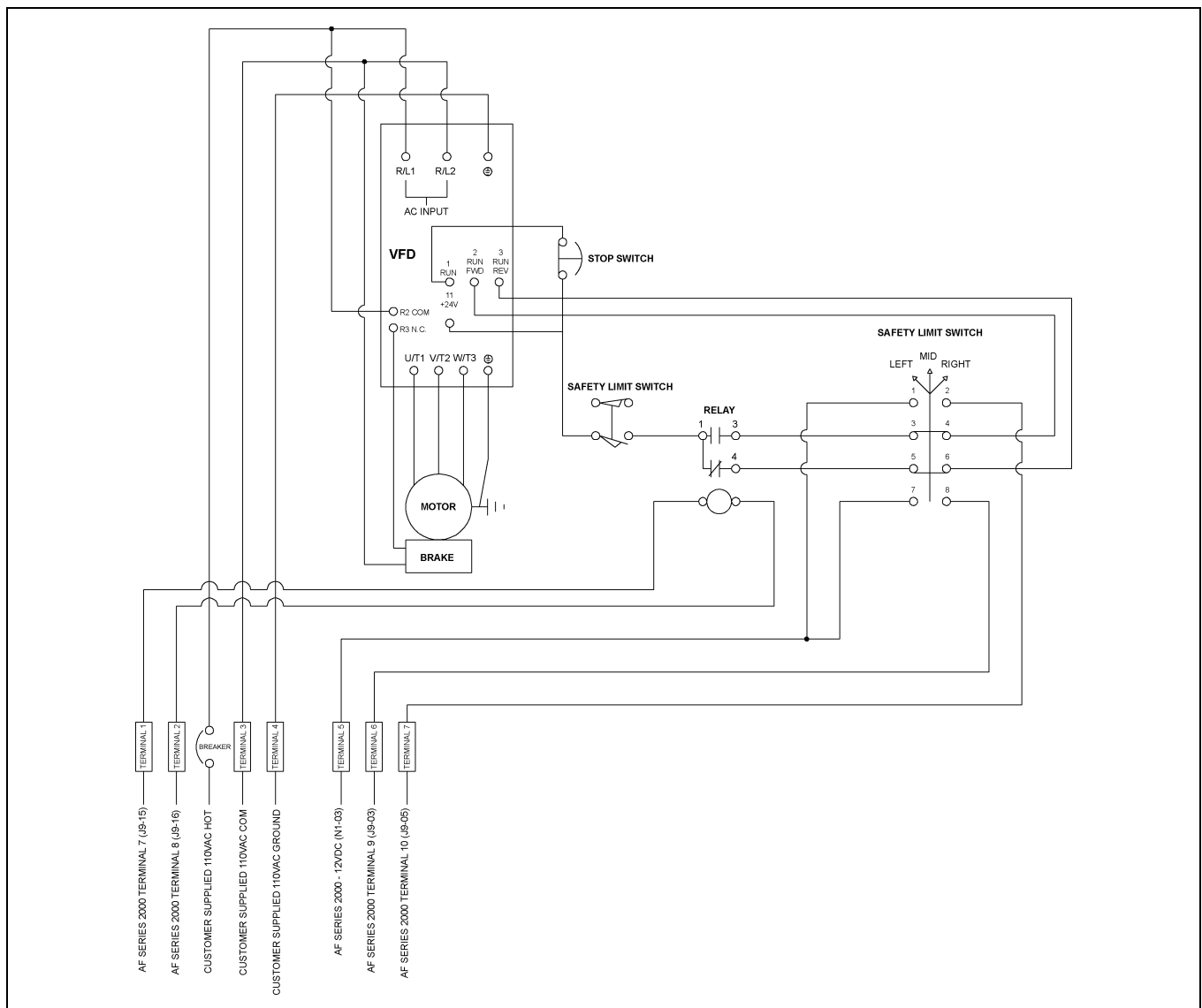

Figure 4F

Autoflow to Optional Wet Supply Rotary Switch Interconnect

NOTE: If the optional wet supply rotary switch is not used, install a jumper between terminals 13 and 14 in the main control box.

The 110V AC rotary switch located in the wet storage tank is used to inform the computer on the availability of wet grain. The Wet Supply Rotary switch use 110V AC to power the motor and 12V DC+ to switch a signal back to the computer.

To wire the Wet Supply Rotary switch to the Autoflow control box do the following:

1. Run four (4) control wires from the Autoflow control box to the Wet Supply Rotary switch.
2. Connect the wires as shown in [Figure 4G](#).

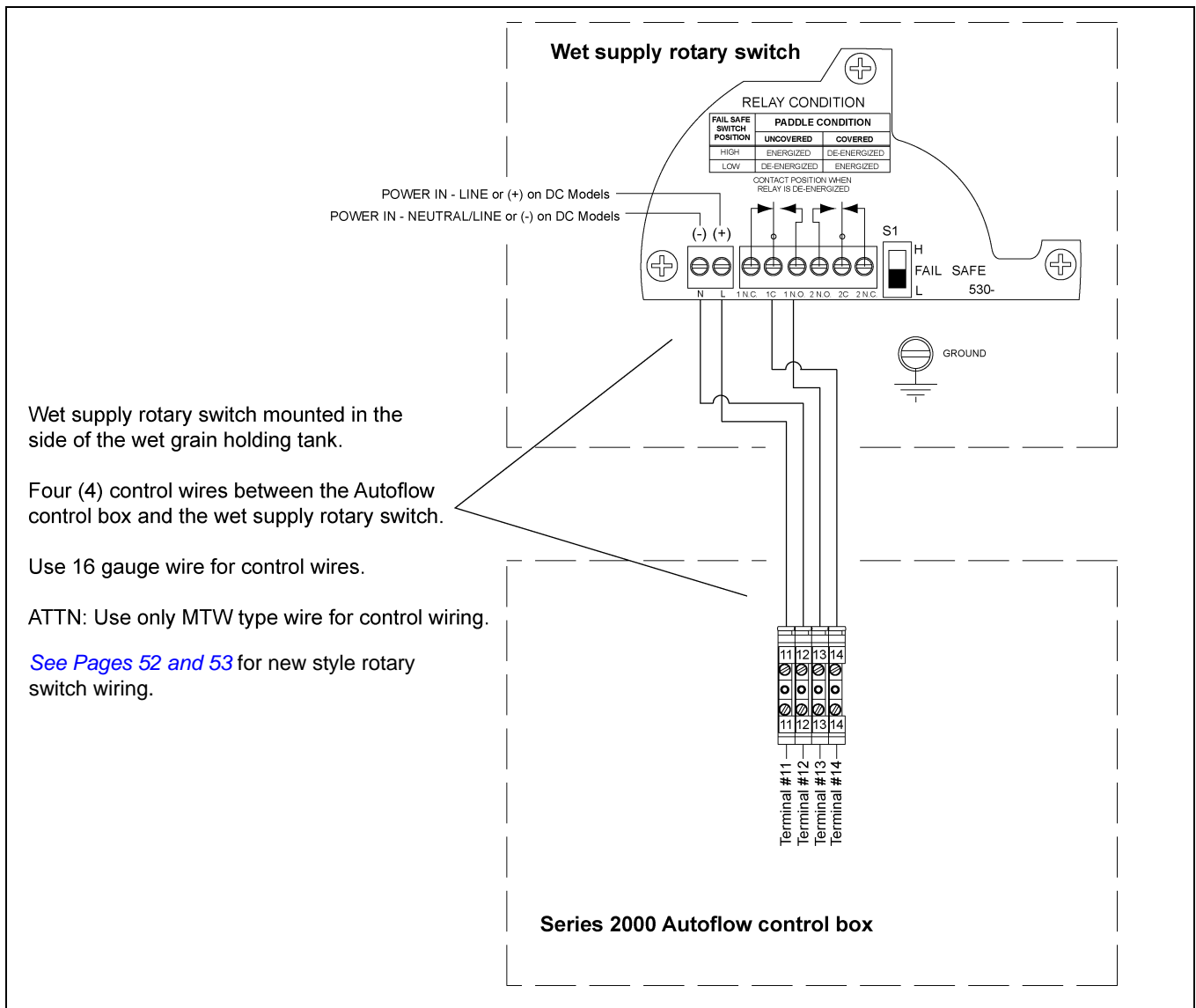

Figure 4G

4. Electrical Power Supply

Autoflow to Storage Chamber Rotary Switch Interconnect

The 110V AC rotary switch located in the storage tank is used to inform the computer on the availability of wet grain. The Storage Chamber Rotary switch is mounted 3' below the fan/heater unit(s). The Storage Chamber Rotary switch use 110V AC to power the motor and 12V DC+ to switch a signal back to the computer.

To wire the Storage Chamber Rotary switch to the Autoflow control box do the following:

1. Run five (5) control wires from the Autoflow control box to the Storage Chamber Rotary switch.
2. Connect the wires as shown in [Figure 4H](#).

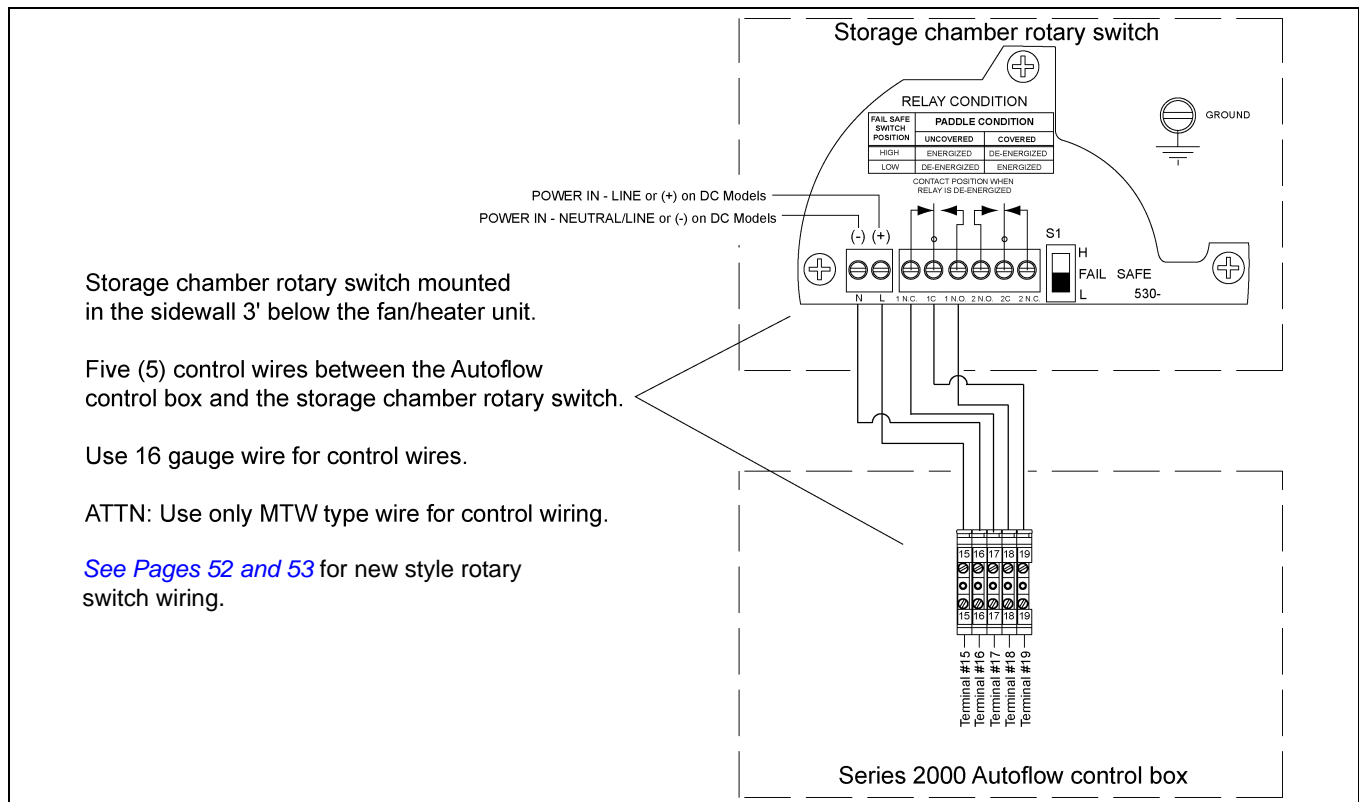

Figure 4H

Autoflow to Drying Chamber Rotary Switches Interconnect

The three (3) 110V AC rotary switches located in the drying chamber are used to inform the computer on the location of grain in the drying chamber. The rotary switch with the shortest extension is the Drying Chamber Overflow Rotary switch. It is used as a safety in the event the Chamber High-Level Rotary switch fails. The rotary switch with the longest extension is the Drying Chamber Low-Level Rotary switch. It is used to inform the computer when the peak has been covered with grain so the drying process can begin; and, will shut the dryer down if the drying chamber empties unexpectedly. The third rotary switch is the Drying Chamber High-Level Rotary switch. It is used to inform the dryer when the drying chamber is full. The Drying Chamber Rotary switches use 110V AC to power the motor and 12V DC+ to switch a signal back to the computer. The 110V AC, 110V N and the 12V DC+ wires can be jumped from rotary switch to rotary switch to lessen the wires needed.

To wire the Drying Chamber Rotary switches to the Autoflow control box do the following:

1. Run six (6) control wires from the Autoflow control box to the Drying Chamber Rotary switches.
2. Connect the wires as shown in [Figure 4I on Page 51](#).

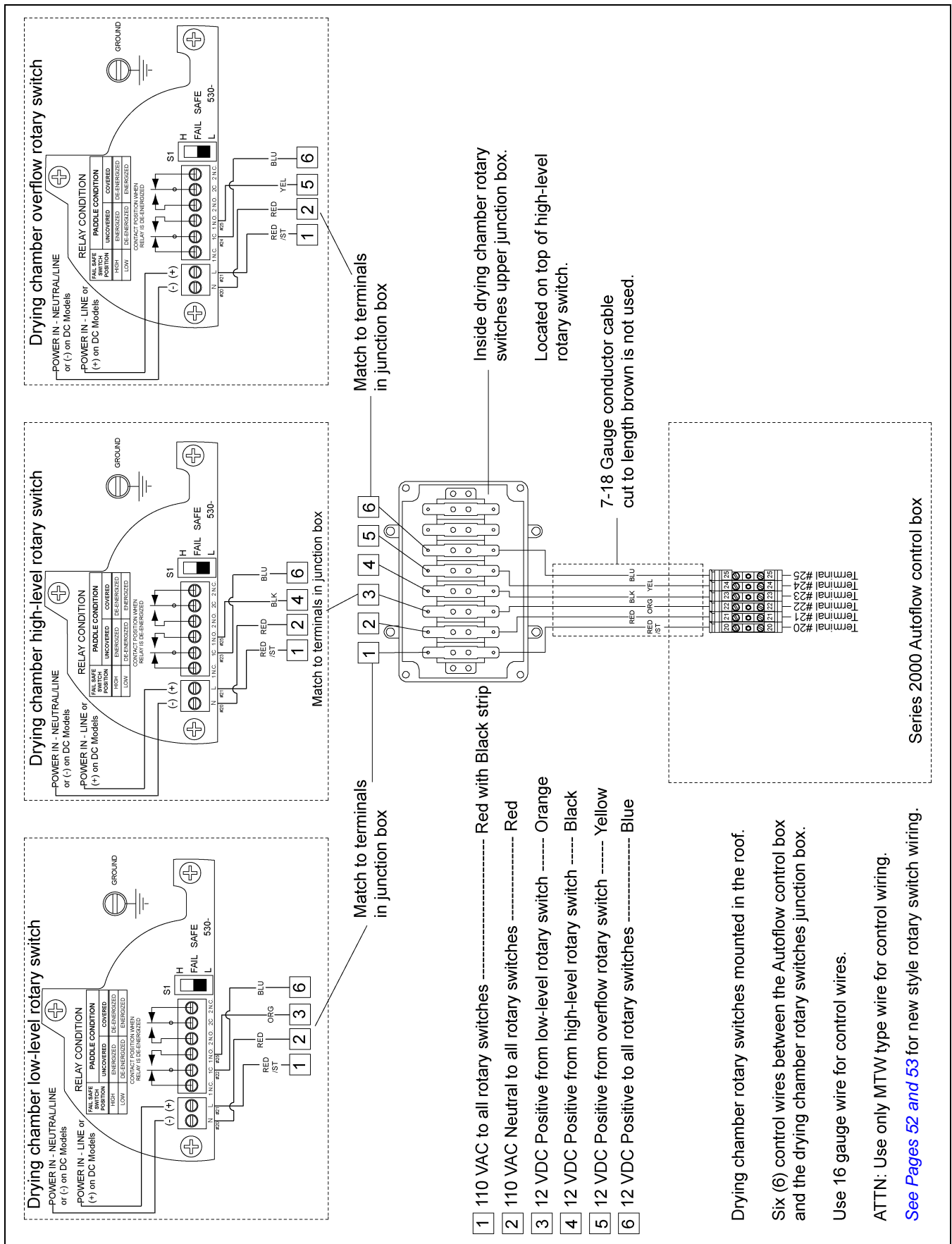

Figure 4I

4. Electrical Power Supply

TopDry Bin Switch Changes

In 2006, the old GR series rotary switches used on TopDrys has been replaced with a new model BMRX series.

The old series had a terminal strip labeled 1 through 5 left to right. It consisted of two (2) motor connectors and one SPDT (Single Pole Double Throw) switch.

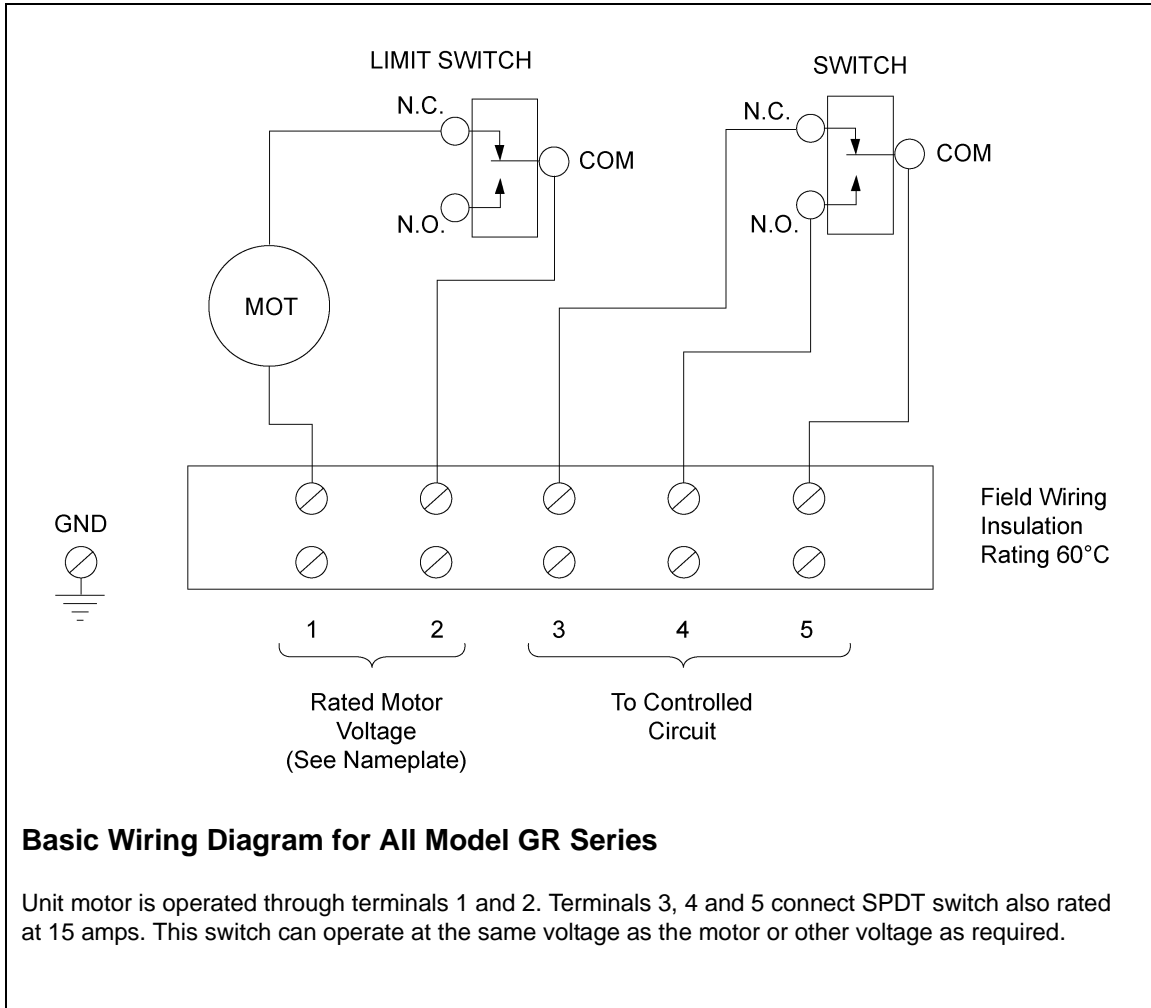

Figure 4J

- Motor 1 = 120 Volt Line
- Switch 3 = Normal Closed
- 2 = 120 Volt Neutral
- 4 = Normally Open
- 5 = Common

The new series has a different layout on the terminal strip. It consists of two (2) motor connectors and two (2) SPDT (Single Pole Double Throw) switches.

TopDry Bin Switch Changes (Continued)

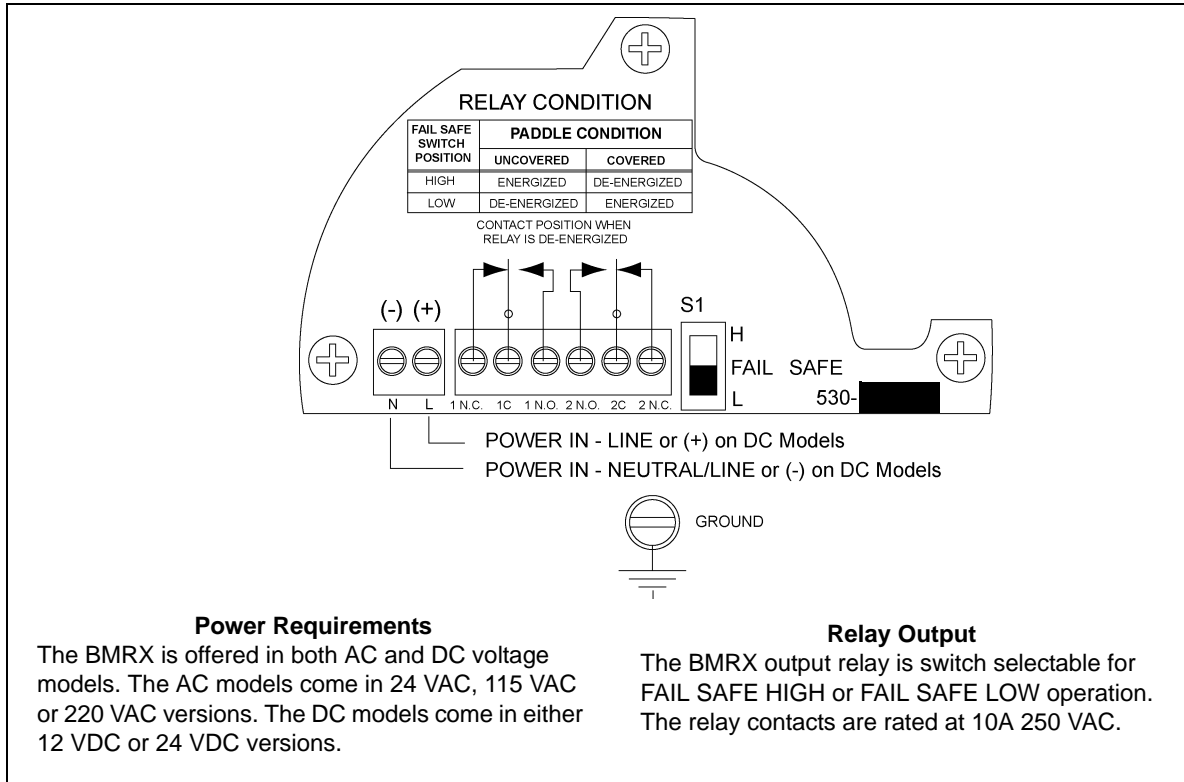

Figure 4K Power Requirements

- Motor N = 120 Volt Neutral
- Switch 1 1 N.C. = Normally Closed
- Switch 2 2 N.O. = Normally Open
- L = 120 Volt Line
- 1 C = Common
- 2 C = Common
- 1 N.O. = Normally Open
- 2 N.C. = Normally Closed

There also is a switch for fail safe which you should leave in the "L" position.

The TopDry wiring diagrams do not show any information other than the terminal label 1-5. Here is the equivalent connections on the new BMRX rotary switches.

Old Switch	New Switch
1	L
2	N
3	1 N.C.
4	1 N.O.
5	1 C

All circuits are between Common and Normally Open except for the Storage Chamber High-Limit switch which monitors both N.O. and N.C.

4. Electrical Power Supply

Autoflow to Fill System Control Box Interconnect

The fill system control box houses the starter(s) for the fill system(s) that load grain into the TopDry Autoflow unit and for the aeration fan. DO NOT run the control wires for the fill system control box in the same conduit used for the power wires for the fill system and aeration fan motors. To wire the fill system control to the Autoflow control box do the following.

1. Run eleven (11) control wires from the Autoflow control box to the fill system control box.
2. Connect the wires as shown in [Figure 4L](#).

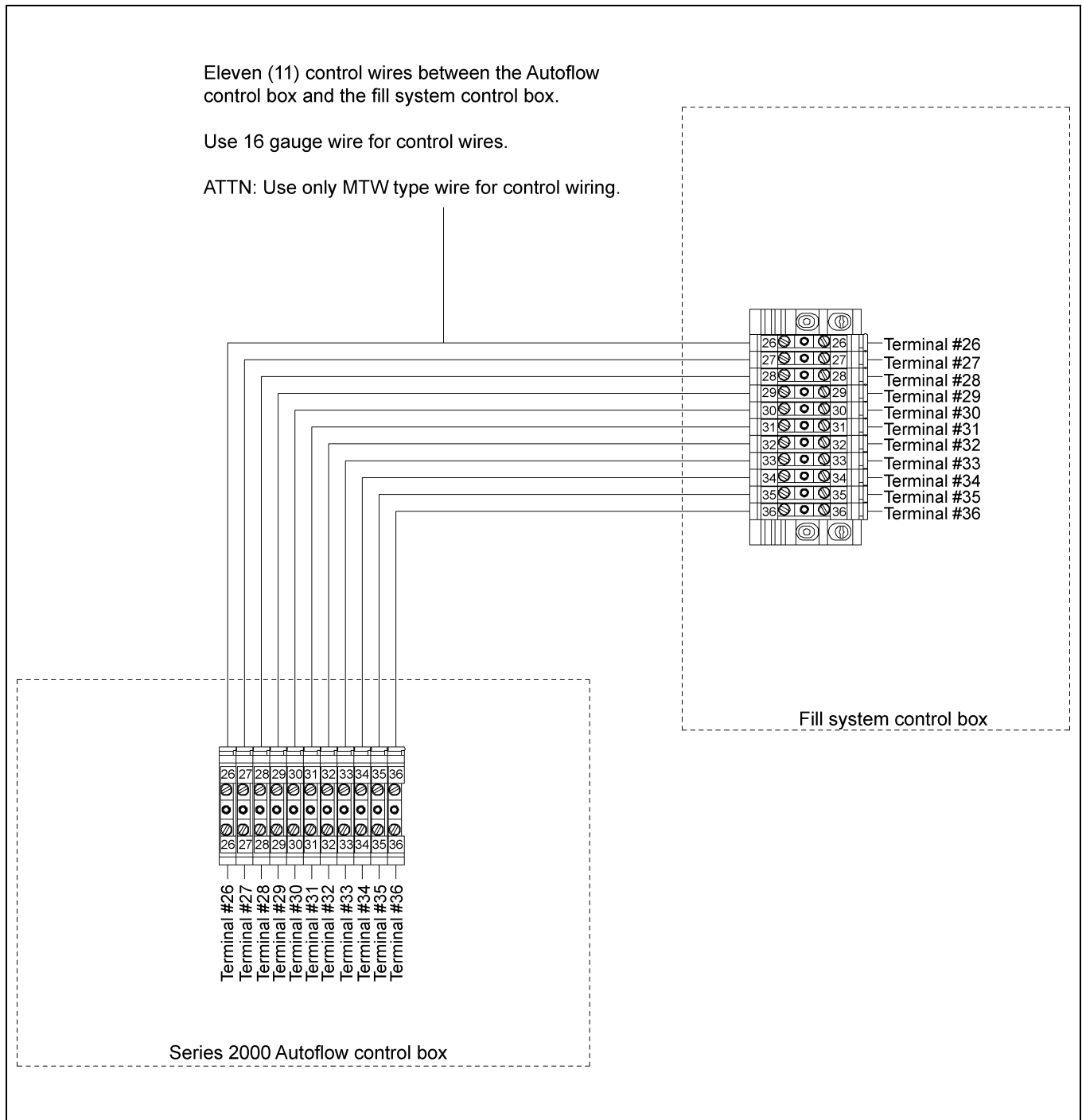

Figure 4L

Autoflow to Ground Interconnect

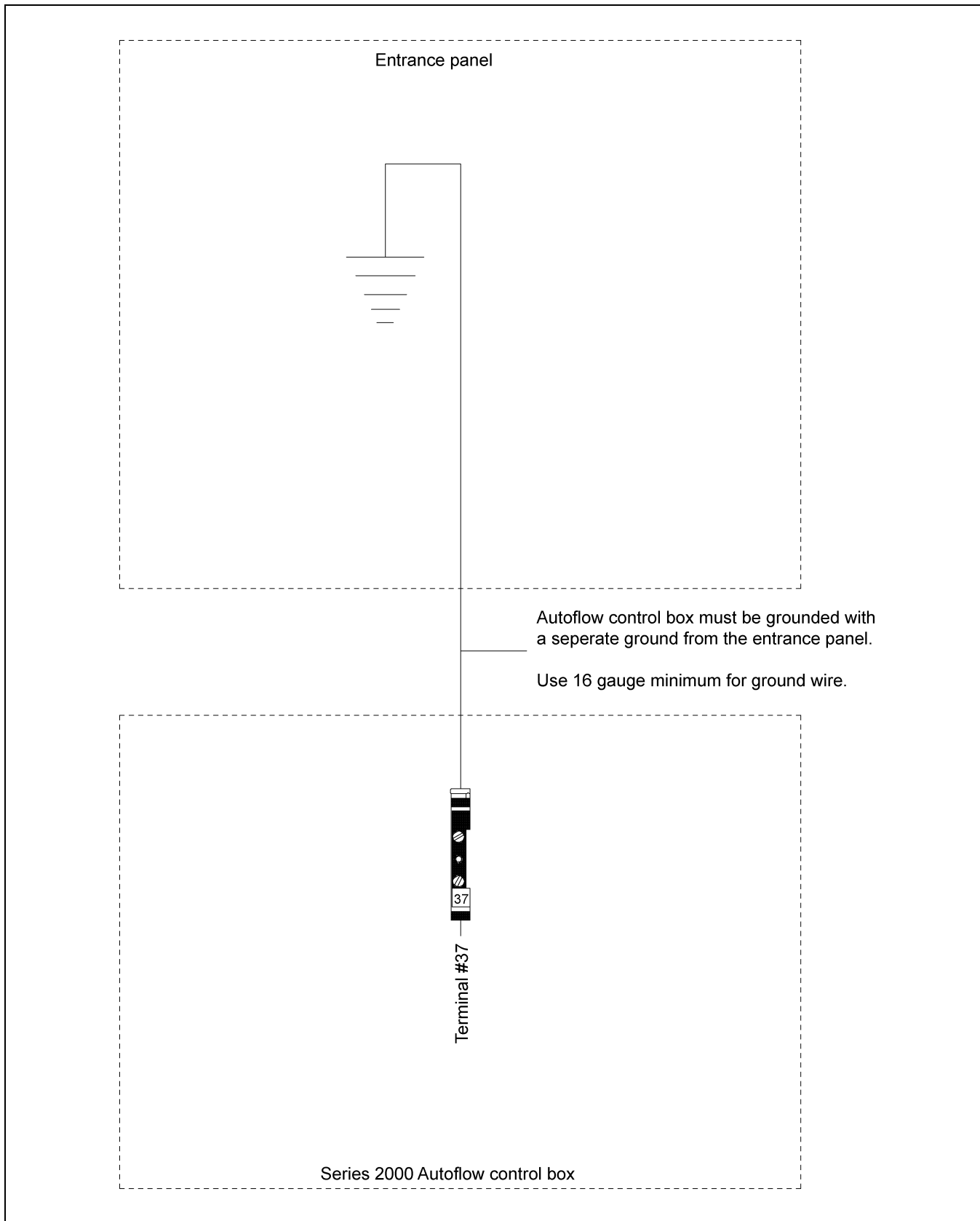

Figure 4M

4. Electrical Power Supply

Fan 2 to Fan 3 Interconnect

A fan 2 unit can be added to operate in unison with the control fan 1 unit and another fan 3 unit. This would create a three (3) fan unit. The interconnect between the fan 2 unit and the fan 3 unit remains the same regardless of the type or presence of a control center. To wire a fan 2 unit to fan 3 unit do the following:

NOTE: Do not use solid wire for interconnection or run control wires with motor wires, high amperage wires or voltage wires above 120 volts.

1. Run four (4) 16 gauge MTW type wires from the fan 2 unit to the fan 3 unit.
2. Connect the wires as shown in [Figure 4N](#).

NOTE: A shielded 16 gauge cable is recommended for use on the network connections. The network connections for this configuration are attached to terminal #7 and terminal #8 in fan 2 and terminal #3 and terminal #4 in fan 3. Ground each end of the shielded cable to the housing. A shielded 16 gauge 2 wire cable can be purchased from GSI. Part #WR-16/2S

Fan #3 and Heater Dip Switch Setting: #1 and #2 - “OFF”/All Others - “ON”

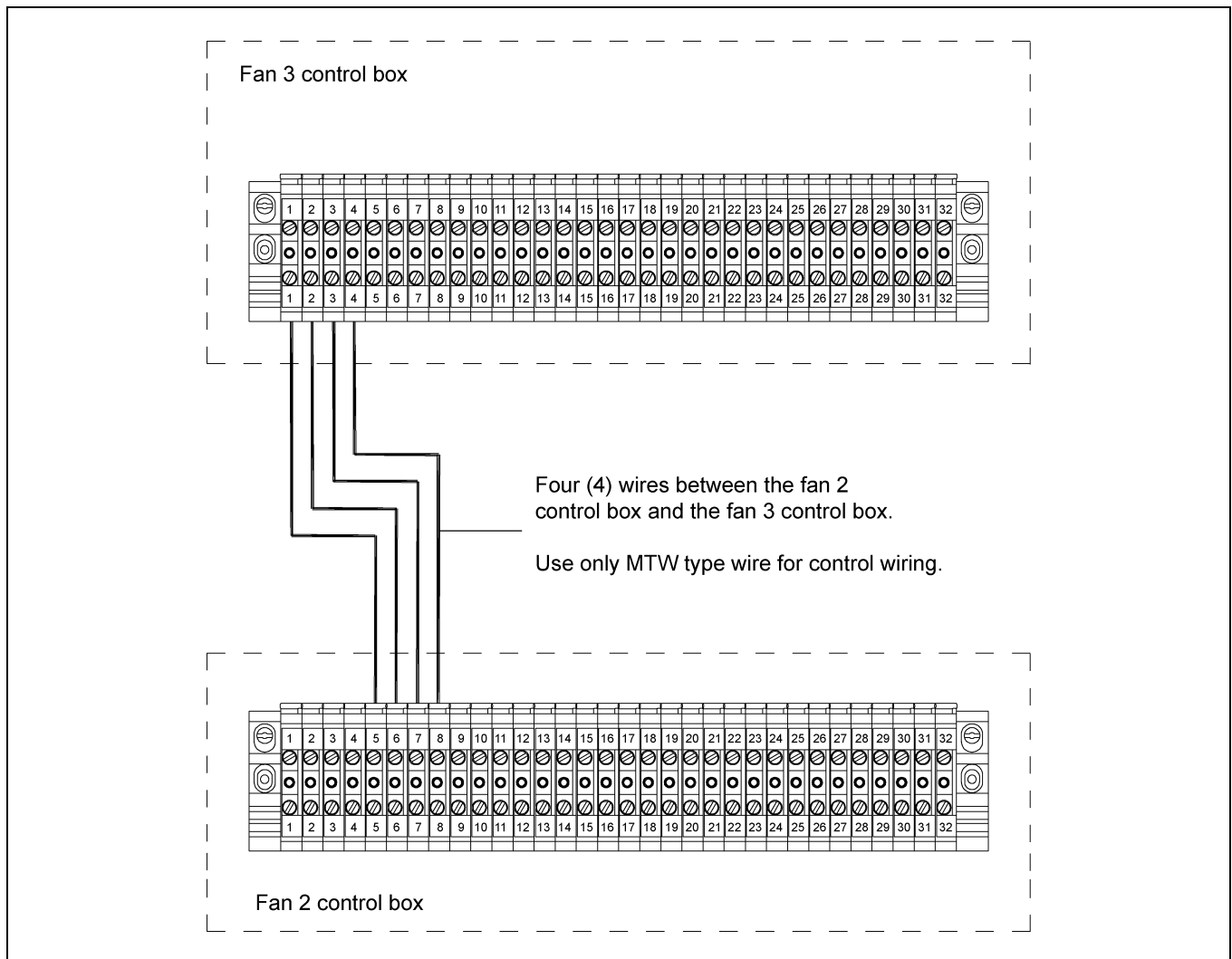

Figure 4N Wiring for a fan 2 unit to fan 3 unit.

GSI Group, LLC Limited Warranty

The GSI Group, LLC ("GSI") warrants products which it manufactures to be free of defects in materials and workmanship under normal usage and conditions for a period of 12 months after sale to the original end-user or if a foreign sale, 14 months from arrival at port of discharge, whichever is earlier. The end-user's sole remedy (and GSI's only obligation) is to repair or replace, at GSI's option and expense, products that in GSI's judgment, contain a material defect in materials or workmanship. Expenses incurred by or on behalf of the end-user without prior written authorization from the GSI Warranty Group shall be the sole responsibility of the end-user.

Warranty Extensions:

The Limited Warranty period is extended for the following products:

	Product	Warranty Period	
AP Fans and Flooring	Performer Series Direct Drive Fan Motor	3 Years	* Warranty prorated from list price: 0 to 3 years - no cost to end-user 3 to 5 years - end-user pays 25% 5 to 7 years - end-user pays 50% 7 to 10 years - end-user pays 75% ** Warranty prorated from list price: 0 to 3 years - no cost to end-user 3 to 5 years - end-user pays 50% † Motors, burner components and moving parts not included. Portable dryer screens included. Tower dryer screens not included.
	All Fiberglass Housings	Lifetime	
	All Fiberglass Propellers	Lifetime	
AP and Cumberland	Flex-Flo/Pan Feeding System Motors	2 Years	
Cumberland Feeding/Watering Systems	Feeder System Pan Assemblies	5 Years **	
	Feed Tubes (1-3/4" and 2.00")	10 Years *	
	Centerless Augers	10 Years *	
	Watering Nipples	10 Years *	
Grain Systems	Grain Bin Structural Design	5 Years	
Grain Systems Farm Fans Zimmerman	Portable and Tower Dryers	2 Years	
	Portable and Tower Dryer Frames and Internal Infrastructure †	5 Years	

GSI further warrants that the portable and tower dryer frame and basket, excluding all auger and auger drive components, shall be free from defects in materials for a period of time beginning on the twelfth (12th) month from the date of purchase and continuing until the sixtieth (60th) month from the date of purchase (extended warranty period). During the extended warranty period, GSI will replace the frame or basket components that prove to be defective under normal conditions of use without charge, excluding the labor, transportation, and/or shipping costs incurred in the performance of this extended warranty.

Conditions and Limitations:

THERE ARE NO WARRANTIES THAT EXTEND BEYOND THE LIMITED WARRANTY DESCRIPTION SET FORTH ABOVE. SPECIFICALLY, GSI MAKES NO FURTHER WARRANTY OF ANY KIND, EXPRESS OR IMPLIED, INCLUDING, WITHOUT LIMITATION, WARRANTIES OF MERCHANTABILITY OR FITNESS FOR A PARTICULAR PURPOSE OR USE IN CONNECTION WITH: (I) PRODUCT MANUFACTURED OR SOLD BY GSI OR (II) ANY ADVICE, INSTRUCTION, RECOMMENDATION OR SUGGESTION PROVIDED BY AN AGENT, REPRESENTATIVE OR EMPLOYEE OF GSI REGARDING OR RELATED TO THE CONFIGURATION, INSTALLATION, LAYOUT, SUITABILITY FOR A PARTICULAR PURPOSE, OR DESIGN OF SUCH PRODUCTS.

GSI shall not be liable for any direct, indirect, incidental or consequential damages, including, without limitation, loss of anticipated profits or benefits. The sole and exclusive remedy is set forth in the Limited Warranty, which shall not exceed the amount paid for the product purchased. This warranty is not transferable and applies only to the original end-user. GSI shall have no obligation or responsibility for any representations or warranties made by or on behalf of any dealer, agent or distributor.

GSI assumes no responsibility for claims resulting from construction defects or unauthorized modifications to products which it manufactured. Modifications to products not specifically delineated in the manual accompanying the equipment at initial sale will void the Limited Warranty.

This Limited Warranty shall not extend to products or parts which have been damaged by negligent use, misuse, alteration, accident or which have been improperly/inadequately maintained. This Limited Warranty extends solely to products manufactured by GSI.

Prior to installation, the end-user has the responsibility to comply with federal, state and local codes which apply to the location and installation of products manufactured or sold by GSI.

This equipment shall be installed in accordance with the current installation codes and applicable regulations, which should be carefully followed in all cases. Authorities having jurisdiction should be consulted before installations are made.



GSI Group
1004 E. Illinois St.
Assumption, IL 62510-0020
Phone: 1-217-226-4421
Fax: 1-217-226-4420
www.gsiag.com



GSI is a worldwide brand of AGCO Corporation.