

Series 2000 Autoflow Fan/Heater and Control Installation Instructions



PNEG-900

Installation
Manual
PNEG-900



a division of
THE GSI GROUP



This equipment shall be installed in accordance iwth the current **INSTALLATION CODES FOR GAS BURNING APPLICANCES ANDEQUIPMENT, CAN1_B149.1 and B149.2**, or applicable provincial regulations which should be carefully followed in all cases. Authorities having jurisdiction shuld be consulted before installations are made.

Roof Warning, Operation & Safety.....	4
SafetyAlertDecals.....	5
SafetyPrecautions.....	6
SafetySign-off Sheet.....	7
an/HeaterandControlBoxMounting.....	8
AutoflowControlBoxBolt Pattern.....	10
Fill System Control Box Mounting.....	11
FillSystem Control Bolt Pattern.....	12
Actuator Control Box Mounting.....	13
Multi-GrainTemperatureSensorWiring.....	15
Grain Temperature Sensor Mounted to Leveling Band Post.....	16
Close-up of Grain Temperature Sensor Wiring.....	17
PlenumTemperatureSensorInstallation.....	18
Airswitch Installation.....	19
WetSupplyRotary Switch.....	21
Storage Chamber High Limit Rotary Switch Installation.....	22
Drying Chamber Rotary Switches.....	25
Drying Chamber Low-Level Rotary Switch Installation.....	26
Drying Chamber High-Level Rotary Switch Installation.....	28
Drying Chamber Overflow Switch Installation.....	30
LPFuelSpecificationsandRecommendations.....	32
NGFuelSpecificationsandRecommendations.....	33
duit Runs.....	34
ElectricalPowerSupply.....	35
Ground Rod.....	36
MotorWiring.....	37
MainPowerSchematic.....	37
ElectricalLoadInformation.....	38
Wire Size Information.....	39
Fill System Control Box Electrical Load Information.....	40
Autoflowto Master Fan/Heater Unit Interconnect.....	42
Autoflow to Actuator Interconnect.....	43
Autoflow to Wet Supply Rotary Switch Interconnect.....	44
Autoflow to Storage Chamber Rotary Switch Interconnect.....	45
Autoflow to Drying Chamber Rotary Switches Interconnect.....	46
Autoflow to Fill System Control Box Interconnect.....	48
Autoflow to Ground Interconnect.....	49
Master to Slave Interconnect.....	50
Slaveto Slave Interconnect.....	51
BatteryHookUp.....	52
Dump Chute Cable Installation.....	53
Warranty.....	55

Roof Damage Warning and Disclaimer

▲ CAUTION!



Excessive vacuum (or pressure) may damage roof. Use positive aeration system. Make sure all roof vents are open and unobstructed. Start roof fans when supply fans are started. Do not operate when conditions exist that may cause roof vent icing.

DC-969

GSI DOES NOT WARRANT ANY ROOF DAMAGE CAUSED BY EXCESSIVE VACUUM OR INTERNAL PRESSURE FROM FANS OR OTHER AIR MOVING SYSTEMS. ADEQUATE VENTILATION AND/OR "MAKEUP AIR" DEVICES SHOULD BE PROVIDED FOR ALL POWERED AIR HANDLING SYSTEMS. GSI DOES NOT RECOMMEND THE USE OF DOWNWARD FLOW SYSTEMS (SUCTION). SEVERE ROOF DAMAGE CAN RESULT FROM ANY BLOCKAGE OF AIR PASSAGES. RUNNING FANS DURING HIGH HUMIDITY/COLD WEATHER CONDITIONS CAN CAUSE AIR EXHAUST OR INTAKE PORTS TO FREEZE.

Series 2000 Autoflow Installation & Operating Instructions

Thank you for choosing a Top Dry Series 2000 Autoflow unit. It is designed to give excellent performance and service for many years.

This manual describes the installation for all standard production Top Dry Series 2000 single fan, multi-fan and 2000 Series Autoflow units. Different models are available for liquid propane or natural gas fuel supply, with either single phase 230 volt, or three phase 208, 220, 380, 460 or 575 volt electrical power.

The principal concern of the GSI Group, Inc. ("GSI") is your safety and the safety of others associated with grain handling equipment. This manual

is written to help you understand safe operating procedures, and some of the problems that may be encountered by the operator or other personnel.

As owner and/or operator, it is your responsibility to know what requirements, hazards and precautions exist, and to inform all personnel associated with the equipment, or who are in the fan area. Avoid any alterations to the equipment. Such alterations may produce a very dangerous situation, where serious injury or death may occur.

Safety Alert Symbol

The symbol shown is used to call your attention to instructions concerning your personal safety. Watch for this symbol; it points out important safety precautions. It means "ATTENTION", "WARNING", "CAUTION", and "DANGER". Read the message and be cautious to the possibility of personal injury or death.



WARNING! BE ALERT!

Personnel operating or working around electric fans should read this manual. This manual must be delivered with the equipment to its owner. Failure to read this manual and its safety instructions is a misuse of the equipment.

The GSI Group, Inc. recommends contacting your local power company, and having a representative survey your installation so the wiring is compatible with their system, and adequate power is supplied to your unit.

Safety decals should be read and understood by all people in the grain handling area. The rotating blade, fire warning decals and voltage danger decal must be displayed on the fan can. The bottom right decal should be present on the inside bin door cover of the two ring door, 24" porthole door cover and the roof manway cover.

If a decal is damaged or is missing contact:

The GSI Group, Inc.
 1004 E. Illinois St.
 Assumption, IL 62510
 217-226-4421

A free replacement will be sent to you.



! WARNING

Stay clear of rotating blade. Blade could start automatically. Can cause serious injury. Disconnect power before servicing.

DC-1225



! WARNING

Flame and pressure beyond door. Do not operate with service door removed. Keep head and hands clear. Can cause serious injury.

DC-1227



! DANGER!



High voltage. Will cause serious injury or death. Lockout power before servicing.

DC-1224

! DANGER

 <p>Rotating augers can kill or dismember.</p>	 <p>Flowing material can trap and suffocate.</p>	 <p>Crusted material can collapse and suffocate.</p>
---	--	---

Keep clear of all augers. DO NOT ENTER this bin!

If you must enter this bin:

1. Shut off and lock out all power.
2. Use safety harness and safety line.
3. Station another person outside the bin.
4. Avoid the center of the bin.
5. Wear proper breathing equipment or respirator.

Failure to heed these warnings will result in serious injury or death.

DC-552

READ THESE INSTRUCTIONS BEFORE OPERATION AND SERVICE SAVE FOR FUTURE REFERENCE

1. Read and understand the operating manual before trying to operate the dryer.
2. Power supply should be OFF for service of electrical components. Use CAUTION in checking voltage or other procedures requiring power to be ON.
3. Check for gas leaks at all gas pipe connections. If any leaks are detected, do not operate the dryer. Shut down and repair before further operation.
4. Never attempt to operate the dryer by jumping or otherwise bypassing any safety devices on the unit.
5. Set pressure regulator to avoid excessive gas pressure applied to burner during ignition and when burner is in operation. Do not exceed maximum recommended drying temperature.
6. Keep the dryer clean. Do not allow fine material to accumulate in the plenum or drying chamber.
7. Use CAUTION in working around high speed fans, gas burners, augers and auxiliary conveyors which START AUTOMATICALLY.
8. Do not operate in any area where combustible material will be drawn into the fan.
9. Before attempting to remove and reinstall any propellor, make certain to read the recommended procedure listed within the servicing section of the manual.
10. Clean grain is easier to dry. Fine material increases resistance to airflow and requires removal of extra moisture.

Proper Use of Product

This product is intended for the use of drying small grains only.

Any other use is a misuse of the product!

This product has sharp edges! These sharp edges may cause serious injury. To avoid injury handle sharp edges with caution and use proper protective clothing and equipment at all times.

Guards are removed for illustration purposes only. All guards must be in place before and during operation.

Use Caution in the Operation of this Equipment

The design and manufacture of this dryer is directed toward operator safety. However, the very nature of a grain dryer having a gas burner, high voltage electrical equipment and high speed rotating parts, does present a hazard to personnel, which can not be completely safeguarded against, without interfering with efficient operation and reasonable access to components.

Use extreme caution in working around high speed fans, gas-fired heaters, augers and auxiliary conveyors, which may start without warning when the dryer is operating on automatic control.

KEEP THE DRYER CLEAN
DO NOT ALLOW FINE
MATERIAL TO ACCUMULATE
IN THE PLENUM CHAMBER
OR SURROUNDING THE OUT-
SIDE OF THE DRYER

Continued safe, dependable operation of automatic equipment depends, to a great degree, upon the owner. For a safe and dependable drying system, follow the recommendations within this manual, and make it a practice to regularly inspect the operation of the unit for any developing problems or unsafe conditions. Take special note of the safety precautions listed above before attempting to operate the dryer.

Fan and Heater Mounting

Note: Do not install this control panel near any Transformers or any other device that will produce an Electro Magnetic Field.

1. Inspect the fan platform for proper installation per instructions in the Top Dry erection manual.
2. Raise the Top Dry fan and heater units to the platform. Use the table to the right to determine the height of the platform from the base of the Top Dry unit.
3. Mount the Top Dry fan and heater units to the bin entrance sheets. Fan legs should set on the platform.

Top Dry Bin Eave Height

Number of Rings	Eave Height
5	18'-5"
6	22'-1"
7	25'-9"
8	29'-5"
9	33'-1"
10	36'-9"
11	40'-5"

Autoflow Control Box Mounting

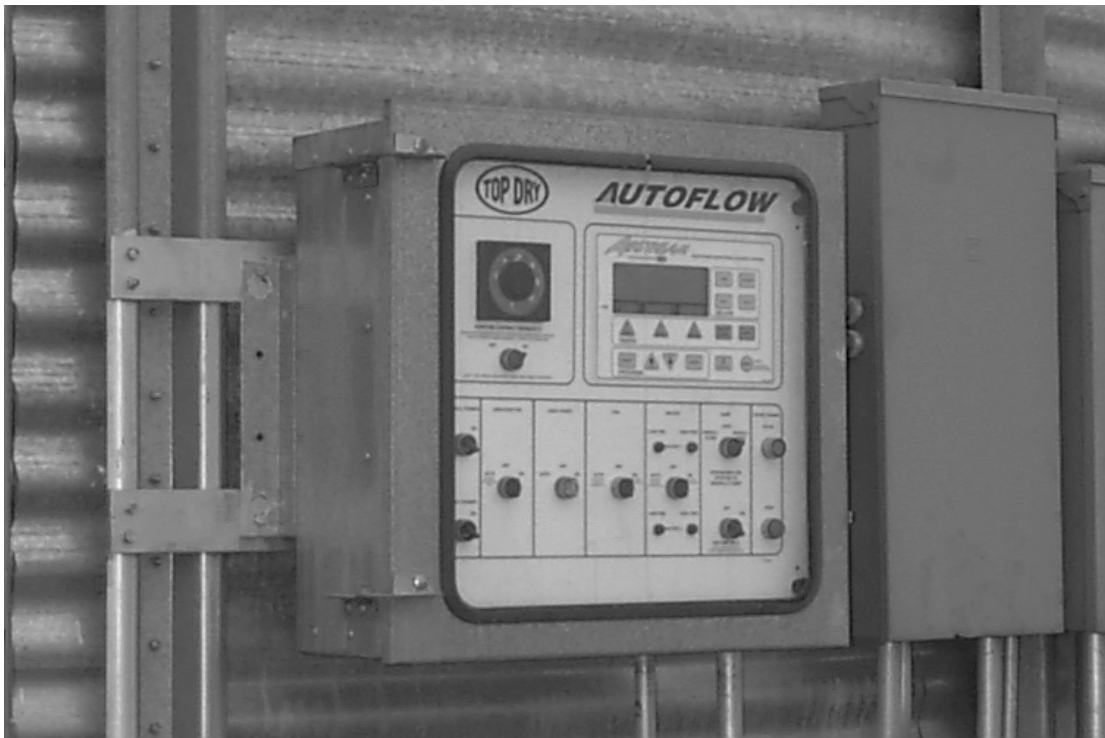

Autoflow Control box mounted on bin.

1. The Autoflow Control Box should be mounted at eye-level. Make sure to mount the Autoflow control box so that the fan and heater unit(s) are in view.
2. Keep in mind that wire will be used to interconnect the Autoflow control Box with the

- fan and heater unit(s), Fill System Control Box, Actuator and all rotary switches.
3. Use the hole pattern in Figure 1 to drill holes for mounting the Autoflow Control Box.

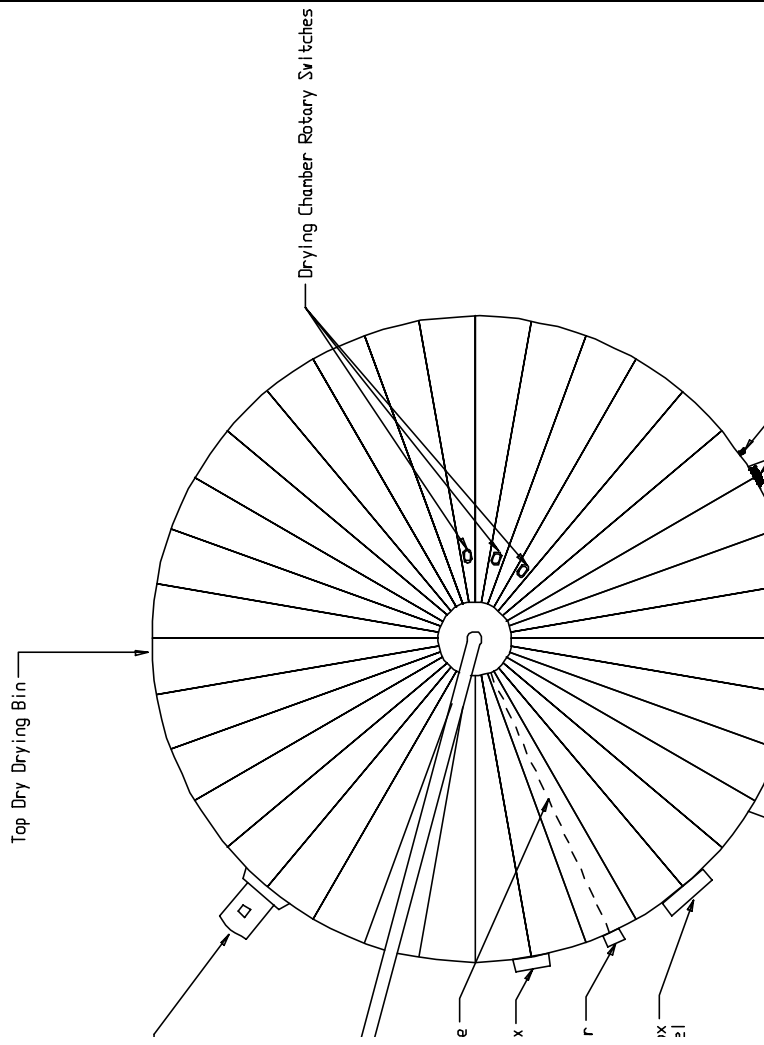

Component Placement

Series 2000 Autoflow Control Box Bolt Pattern

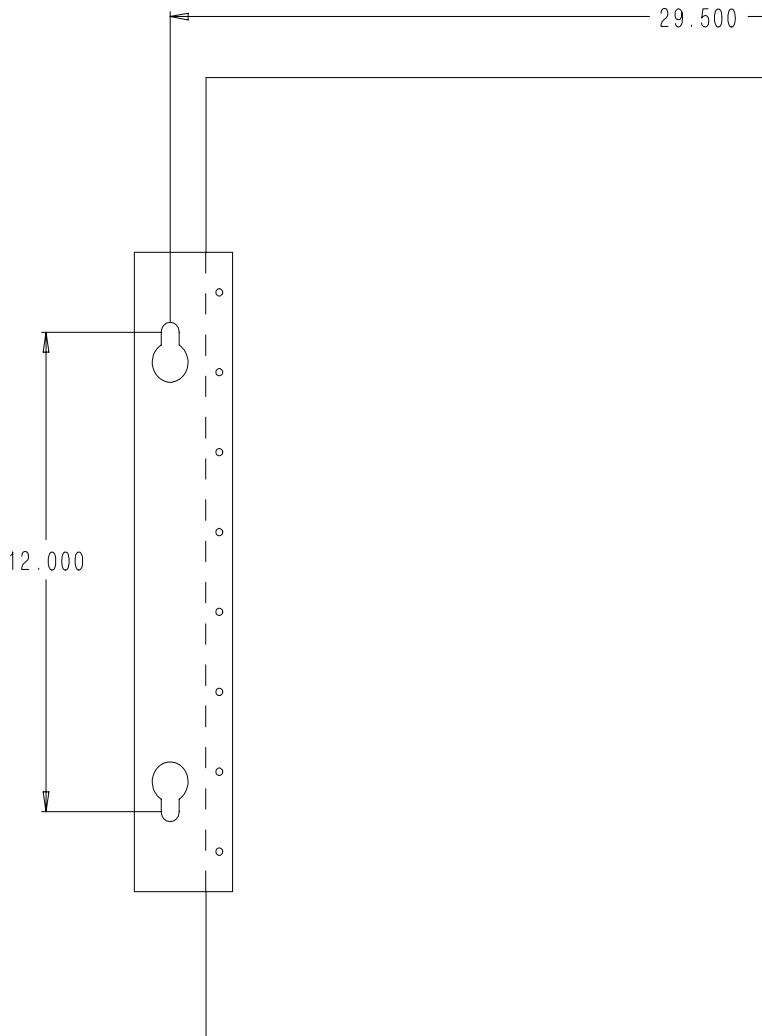
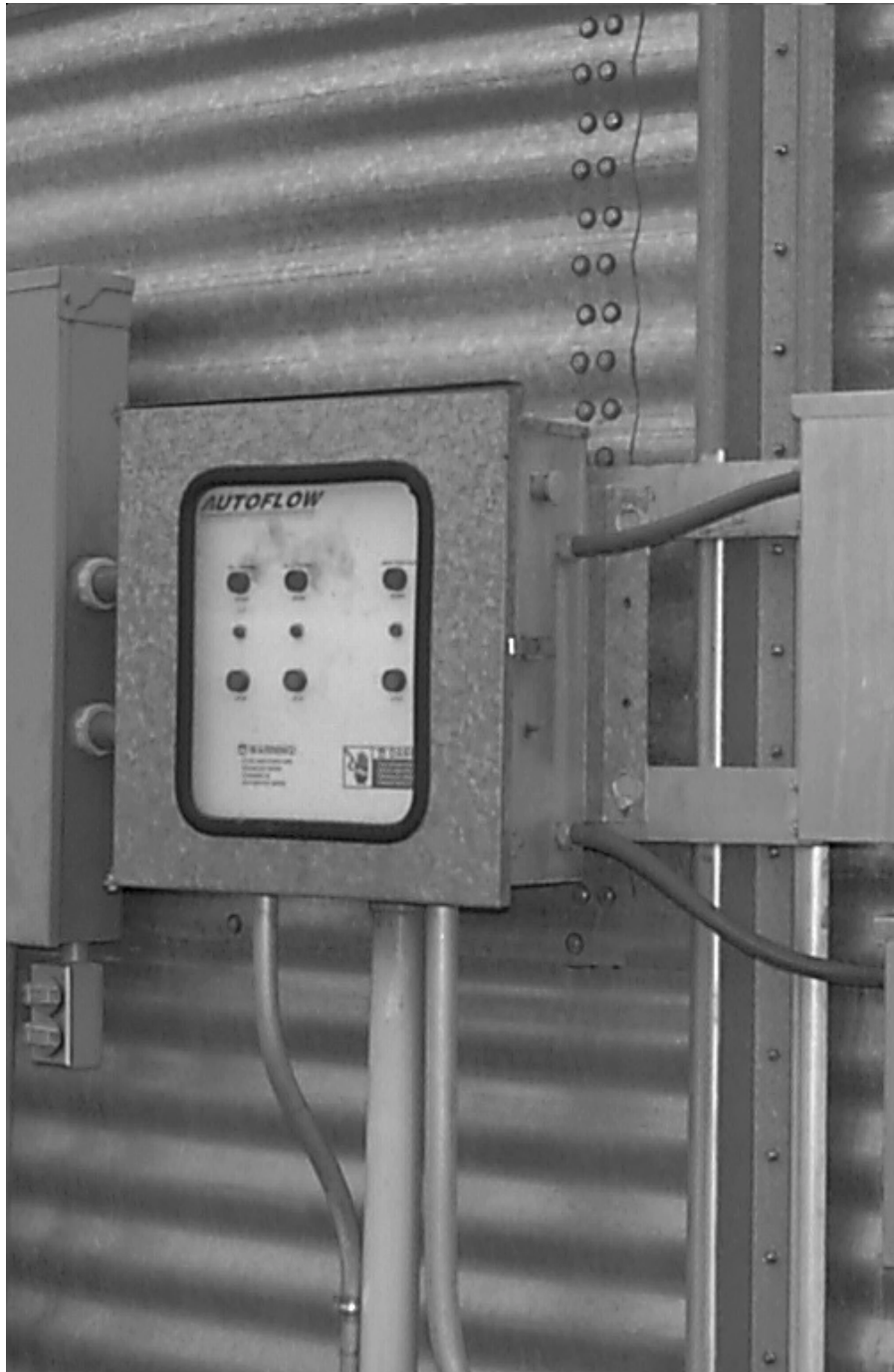

Figure 1: Illustration of the bolt pattern for the Autoflow control box.

Fill System Control Box Mounting

- 1) The Fill System control Box should be mounted at eye-level. Make sure to install the Fill System Control Box so that the Fill System(s) and Aeration fan are in view.
- 2) Keep in mind that wire will be used to interconnect the Fill System Control Box with the Autoflow Control Box; and, that power wires will have to be run from the entrance panel to the Fill System control Box to power the Fill System and Aeration fan motors, which will also run from the Fill System Control Box.
- 3) Use the pattern in Figure 2 to drill holes for the Fill System Control Box.

Fill System Control Box Mounted to Bin

Fill System Control Box Mounting

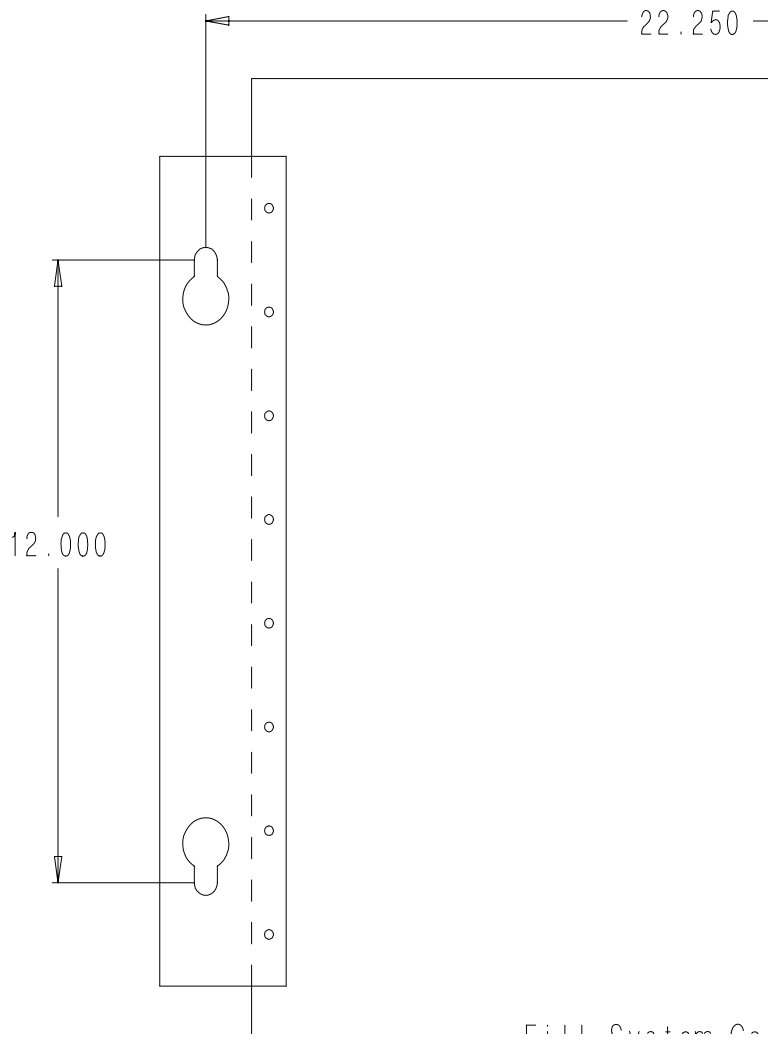

Fill System Co
Figure 2: Fill System Control Box Bolt Pattern

Actuator Control Box Mounting

- 1) Mark the third sidewall ring from the ground to indicate the cable path if dump chutes and cable are already installed.
- 2) Make sure that all dump chutes and chains are EVENLY adjusted so that when one chute is level the others are level as well.
- 3) Keep in mind that wire will be used to interconnect the Actuator Control Box with the Autoflow Control Box; and, that a 110V power supply will need to run from the entrance panel to the Actuator Control Box to power the 24V DC battery charger.
- 4) Use the pattern in Figure 3 to drill holes for the Actuator Control Box.
- 5) If the horizontal seam bolts are within 1" horizontally of the hole pattern shown, existing holes may be used to attach the actuator.
- 6) Use four 5/16" x 1.1/4" bin bolts and washers with bolt heads to the inside of the bin.



Actuator Control Box Mounted to Bin

- 7) Do not attach the dump chute cable to the actuator at this time. The cable should not be installed until after the actuator unit is completely wired and tested.

Actuator Control Box Mounting

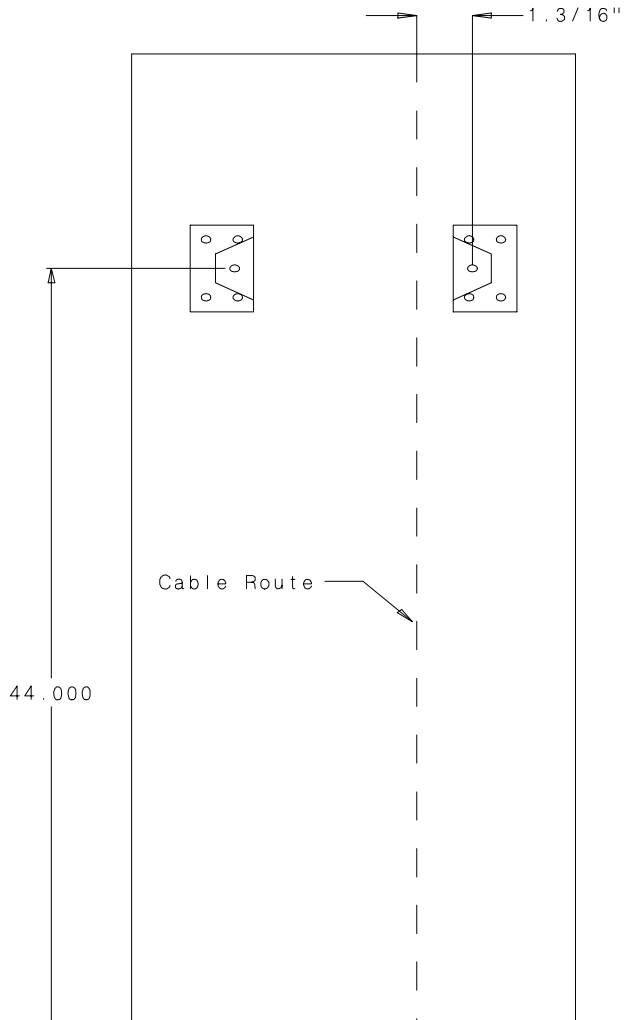

Figure 3: Bolt pattern to drill holes for the Actuator Control Box

Multi-Grain Temperature Sensor

1. Remove the two wires attached to the grain temperature sensor connected to terminal #22 and terminal #23 in the fan control box.
2. Mount the four grain temperature sensor brackets evenly around the drying chamber on outside leveling band posts (figure 5).
3. With bin bolts mount the bracket so the sensor is 10.1/2" above the floor sheet rib.
4. Wire tie the cords so they feed up the leveling band post, and across the top leveling band.
5. Take the cords through the space between the roof and the top sidewall sheet. There should be enough on all temperature sensor brackets to exit the drying chamber at the same place.
6. Run the cords into the junction box after the junction box has been mounted to the bin.
7. Wire the four temperature sensors as shown below and on page 17.

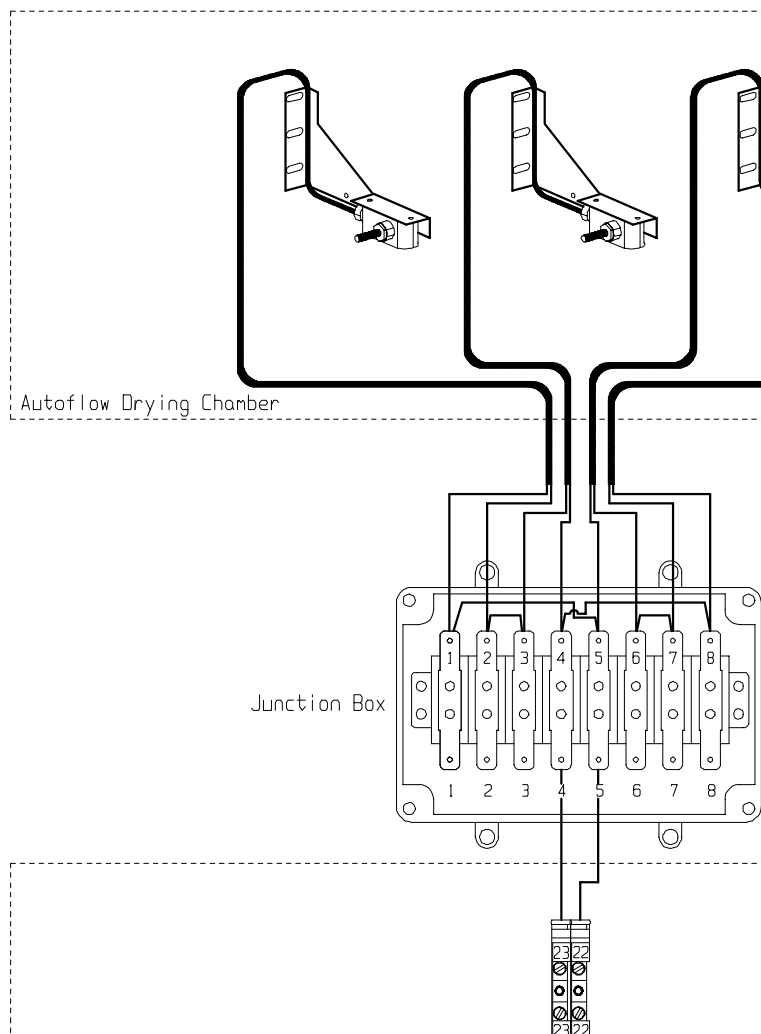

Figure 4: Illustration of the Grain Temperature Sensor Interconnection

Grain Temperature Sensor Mounted to Leveling Band Post

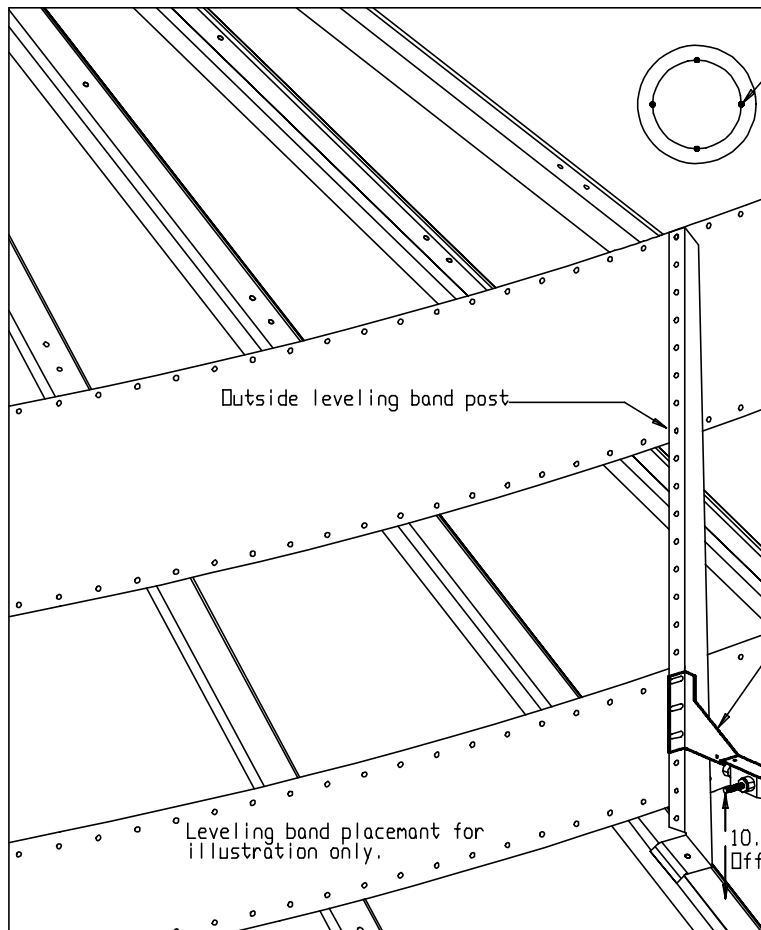
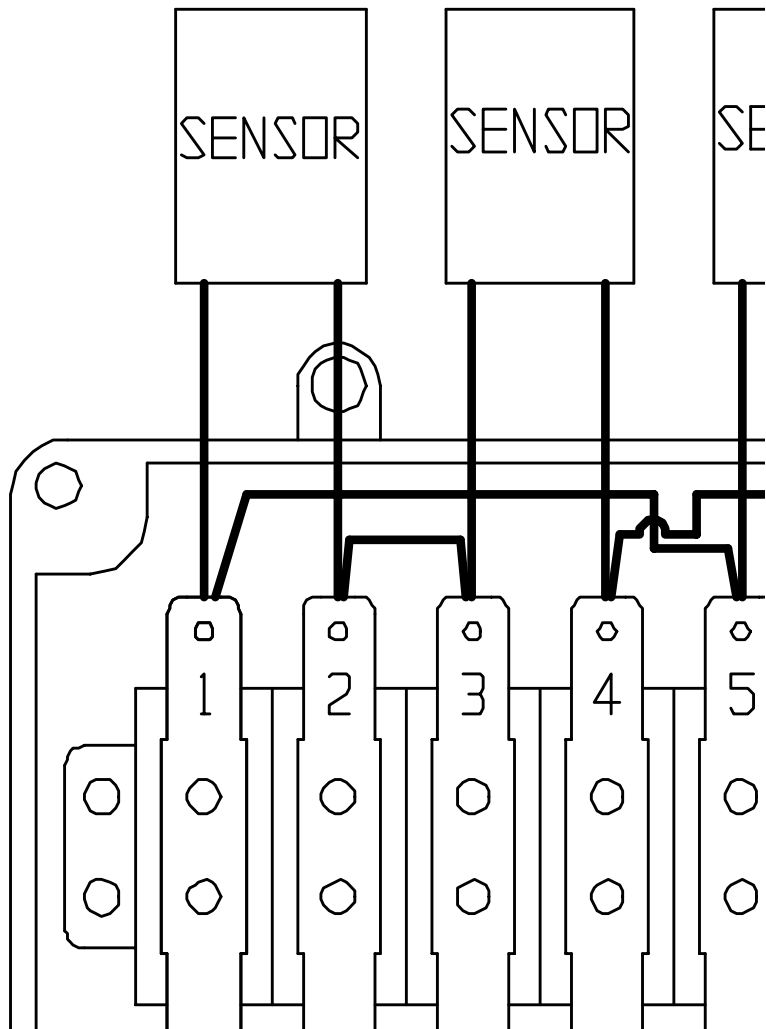

Figure 5: Illustration of grain temperature sensor mounted on outside leveling band post.

Close-Up Detail of Grain Temperature Sensor Wiring



Plenum Temperature Sensor

The plenum temperature sensor is the small grey PVC junction box attached by a cord to the fan/heater control box on the master fan/heater unit.

1. On either side of the fan/heater, drill one 3/4" hole even with the fan/heater unit in a valley on the bin sidewall.
2. Insert the probe through the 3/4" hole.
3. Position the housing so the cord exits the housing horizontally, and the tabs fall on the sidewall peaks.
4. Use two self drilling screws to mount the housing to the bin sidewall.
5. Caulk between the housing and the sidewall to seal.



Plenum temperature sensor on the bin sidewall.

Important!

If the Top Dry is a two fan unit, do not mount the plenum temperature sensor between the two fan/heater units.

Plenum hi-limit installation

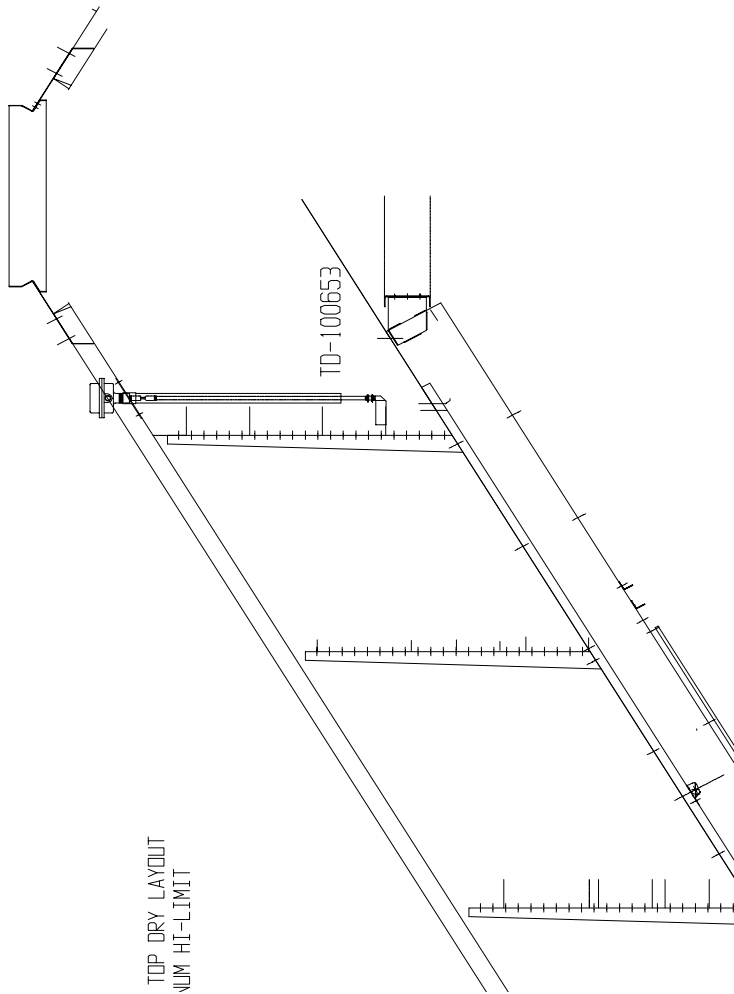

TOP DRY LAYOUT
↓
HI-LIMIT

TOP DRY PLENUM HI LIMIT INSTALLATION

1. Assemble two pieces of conduit together with coupler.
2. Mount conduit clamps to conduit assembly.
3. Locate conduit assembly on the bottom of a rafter at least 2 feet to one side of the fan entrance. Do not install between two fan entrances.
4. Mark bin wall where conduit will pass through and drill a hole just large enough to allow the conduit to pass through. Seal this with caulking when complete.
5. Install white PVC box assembly on outside of bin wall.
6. Insert 10' capillary into conduit assembly.
7. Connect SJO cord to hi limit and connect wires to terminals 20 and 21 on the master fan terminal strip. These terminals are J7-08, and J7-03.

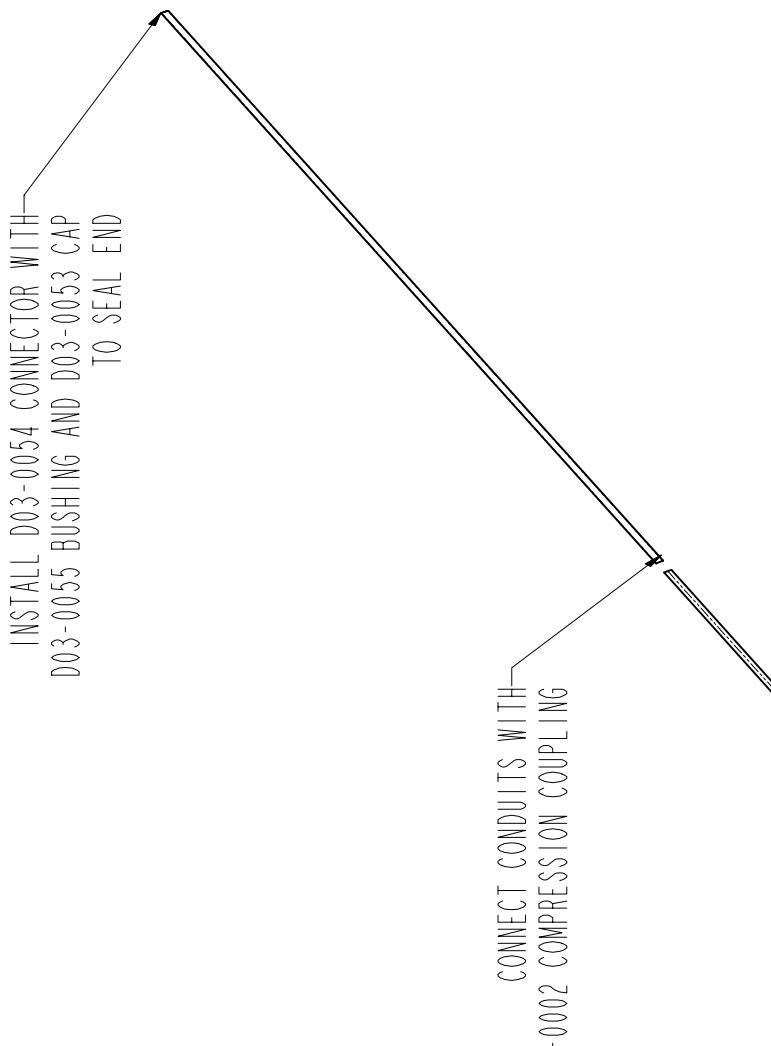

Wet Supply Rotary Switch

- 1) Drill a 2" diameter hole through the hopper bottom.
If a flat bottom bin is being used for a wet storage tank the Wet Supply Rotary Switch would be mounted 45 degrees up the sidewall from the center of the bin. Example: If the wet storage bin is 18' in diameter then the Wet Supply Rotary Switch would be mounted 9' up the sidewall.
- 2) If the bin is 2.66" corrugation the hole should be centered on an outside hill.
- 3) If the bin is 4.00" corrugation the hole should be centered on an outside valley.
- 4) Use the mounting plate as a pattern and drill four 3/8" holes through the sidewall at the switch location so the plate can be bolted to the bin.
- 5) Add foam weather strip around the top and side of the mounting plate.
- 6) Caulk the underside of the mounting plate, on all sides of the 2" hole, and where the plate meets the bin.
- 7) Bolt the mounting plate to the sidewall.
- 8) Attach the flex coupling to the rotary switch power pack using a roll pin.
- 9) Attach the 1-vane paddle to the flex coupling as shown in figure 6.
- 10) Apply teflon tape or pipe sealant (not included) to the rotary switch power pack threads and thread the rotary switch power pack into the mounting plate coupling.
- 11) Make sure that the conduit hole is facing down or is horizontal.

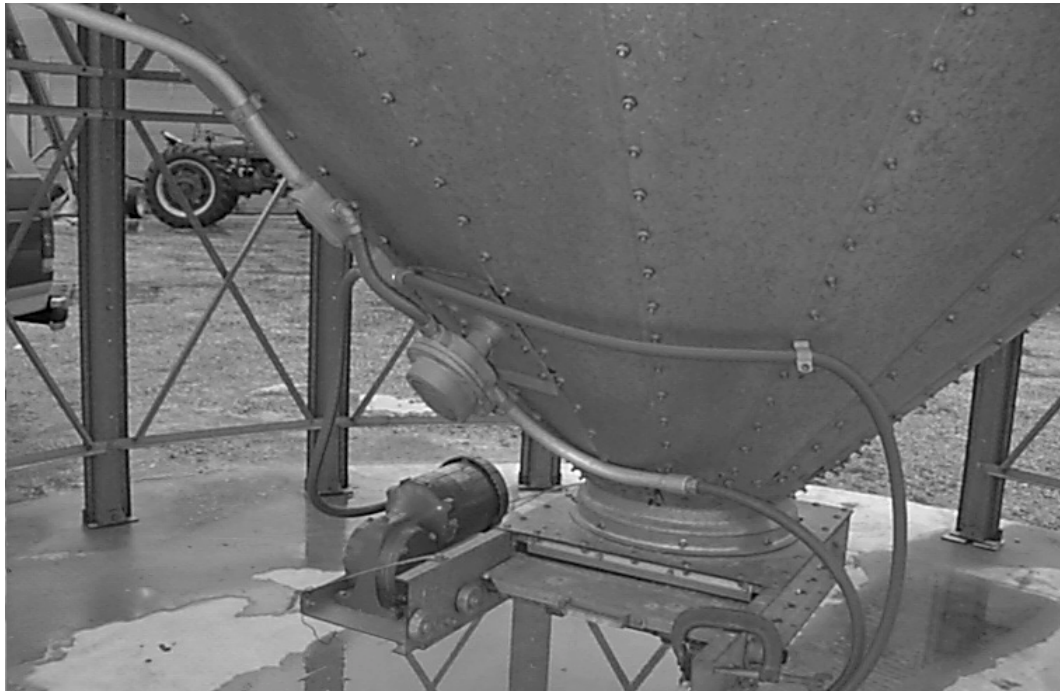

Wet Supply Rotary Switch Mounted on Wet Supply Tank

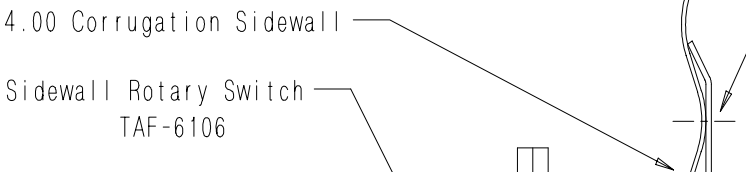
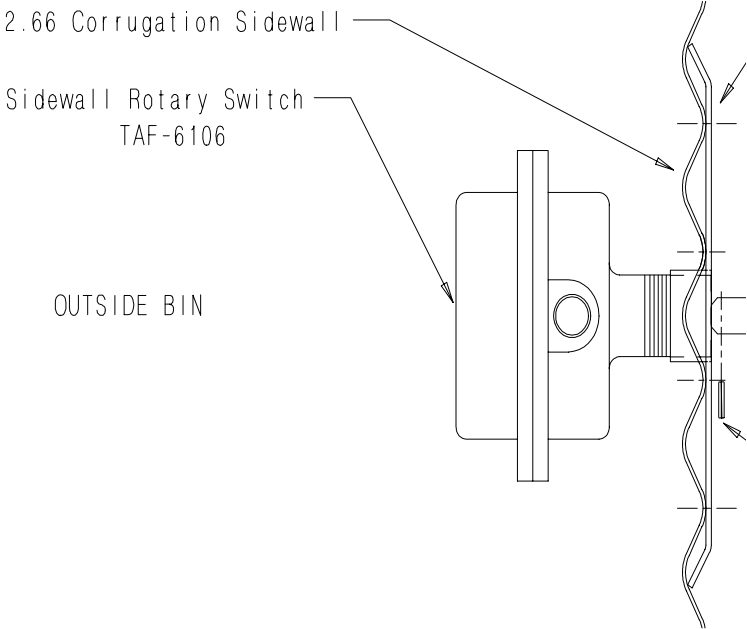

Figure 6

Storage Chamber High Limit Rotary Switch Installation

- 1) Drill a 2" diameter hole through the sidewall 3' below the fan/heater.
- 2) If the bin is 2.66" corrugation the hole should be centered on an outside hill.
- 3) If the bin is 4.00" corrugation the hole should be centered on an outside valley.
- 4) Use the mounting plate as a pattern and drill four 3/8" holes through the sidewall at the switch location so the plate can be bolted to the bin.
- 5) Add foam weather strip around the top and side of the mounting plate.
- 6) Caulk the underside of the mounting plate, on all sides of the 2" hole, and where the plate meets the bin.
- 7) Bolt the mounting plate to the sidewall.
- 8) Attach the flex coupling to the rotary switch power pack using a roll pin.
- 9) Attach the 1-vane paddle to the flex coupling as shown in figure 7.
- 10) Apply teflon tape or pipe sealant (not included) to the rotary switch power pack threads and thread the rotary switch power pack into the mounting plate coupling.
- 11) Make sure that the conduit hole is facing down or is horizontal.



Storage chamber rotary switch.

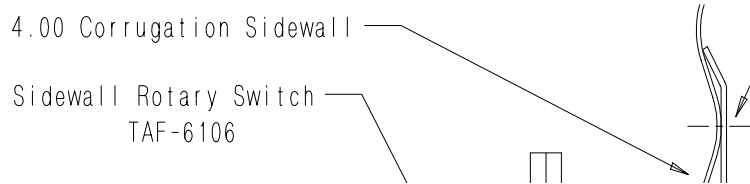
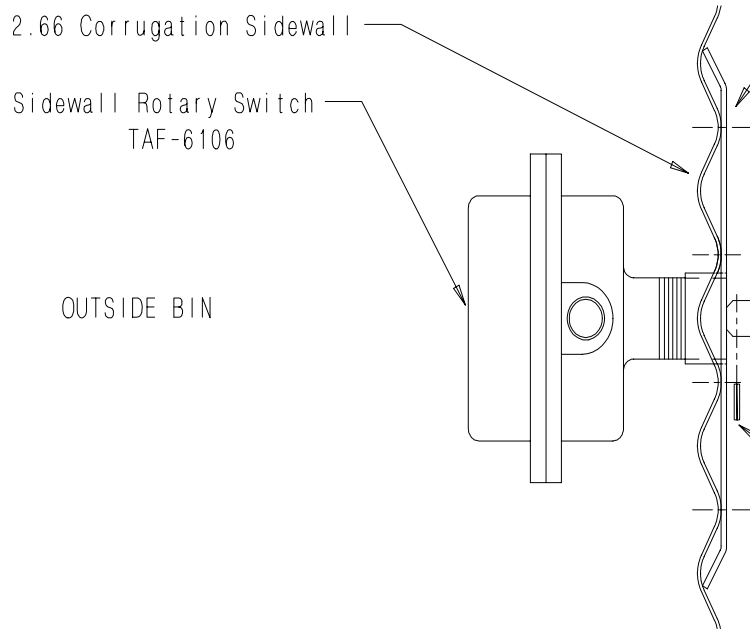

Figure 7

The three (3) Drying Chamber Rotary Switches are used by the series 2000 Autoflow to monitor the location of grain in the Drying Chamber. The rotary switch with the shortest shaft extension is the Drying Chamber Overflow Rotary Switch. It is used as a safety in the event the Chamber High Level Rotary Switch fails. The rotary switch with the longest extension is the Drying Chamber Low Level Rotary Switch. It is used to inform the computer when the peak has been covered with grain so the drying process can begin; and, will shut down if the drying chamber empties unexpectedly. The third rotary switch is the Drying Chamber High Level Rotary Switch. It is used to inform the dryer when the drying chamber is full so loading can stop.

When mounting the Drying Chamber Rotary Switches some foresight is needed. The Drying Chamber Rotary Switches should be located in close proximity to one another to lessen the amount of conduit and wiring required. The rotary switches should also be mounted so that they are located in

an area of the drying chamber that fills evenly with the rest of the drying chamber. The component placement on page 9 shows the placement of the Drying Chamber Rotary Switches in relation to the Fill System #1 transport auger/downspout.

The rotary switches should NOT be located in a part of the drying chamber that fills unevenly with the rest of the drying chamber. If the area of the drying chamber where the rotary switches are located fills faster than the rest of the drying chamber the drying chamber will not fill to capacity and uneven drying will result. If the area of the drying chamber where the rotary switches are located fills slower than the rest of the drying chamber an overflow situation may occur.

It is very critical that the drying chamber fill evenly and that the grain falls from Fill System #1 directly onto the perforated cone in the drying chamber.

Drying Chamber Rotary Switches Mounted in Bin Roof

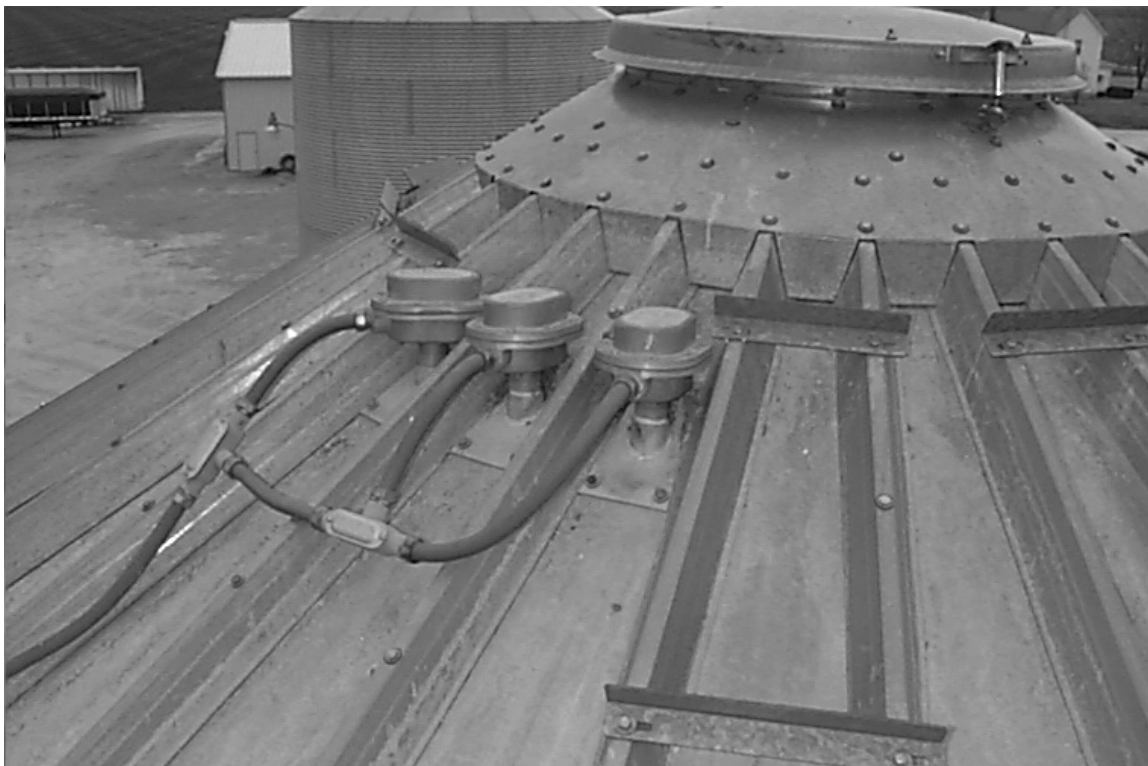

Drying Chamber Low-Level Rotary Switch Installation

- 1) Drill a 2" diameter hole through the roof panel at the location shown in figure 8.
See component placement on page 9 for proper placement in relation to fill auger.
- 2) Use the mounting plate as a pattern and drill four 3/8" holes through the roof panel at the switch location so the plate can be bolted to the roof.
- 3) Attach the flex coupling to the rotary switch power pack using a roll pin.
- 4) Apply teflon tape or pipe sealant (not included) to the rotary switch power pak threads and thread the rotary switch power pack into the mounting plate coupling.
- 5) Make sure that the conduit hole is at right angles with the roof panel ribs or facing towards the eave.
- 6) Caulk the underside of the mounting plate and on all sides of the 2" hole.
- 7) Bolt the assembly to the roof panel.
- 8) Attach the shaft extension according to figure 9.
- 9) Apply teflon tape or pipe sealant (not included) to the shaft guard.
- 10) Thread to underneath side of mounting plate.
- 11) Add the 1/4" drilled coupling to the shaft extension using the cotter pin.
- 12) Attach the 1-vane paddle to the flex coupling as shown in figure 9.

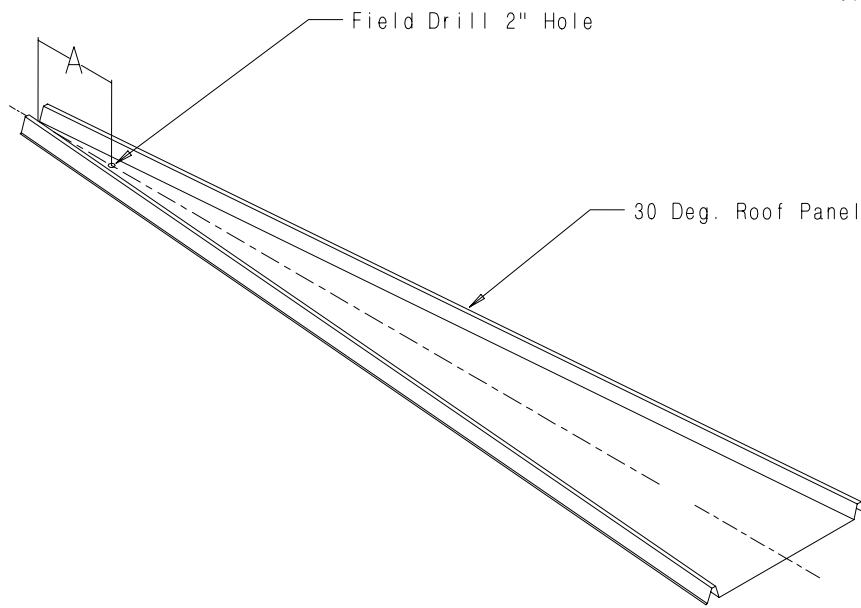

Top Dry Bin Diameter	"A"
18' - 24'	23.50"
27' & 30'	19.00"

Figure 8

Low-Level Rotary Switch — 30 Deg. Roof

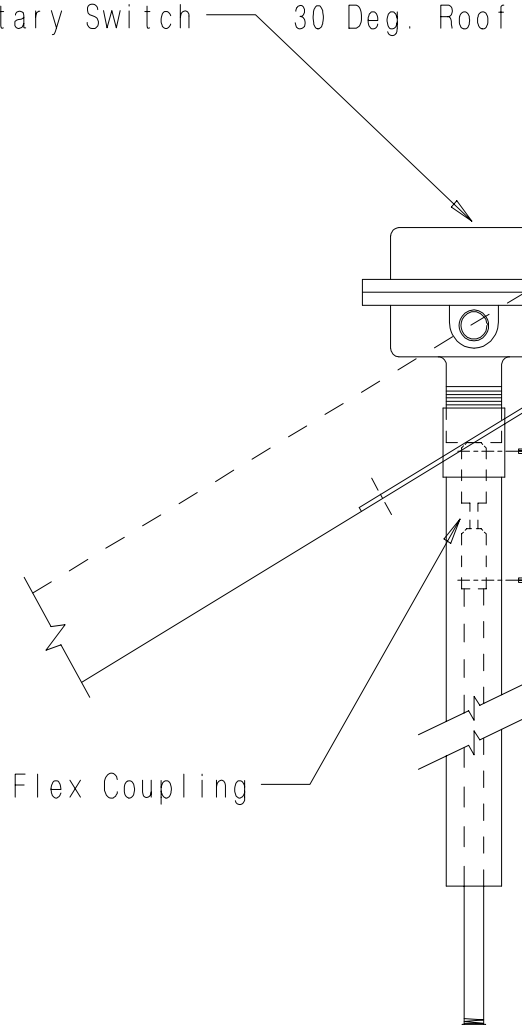
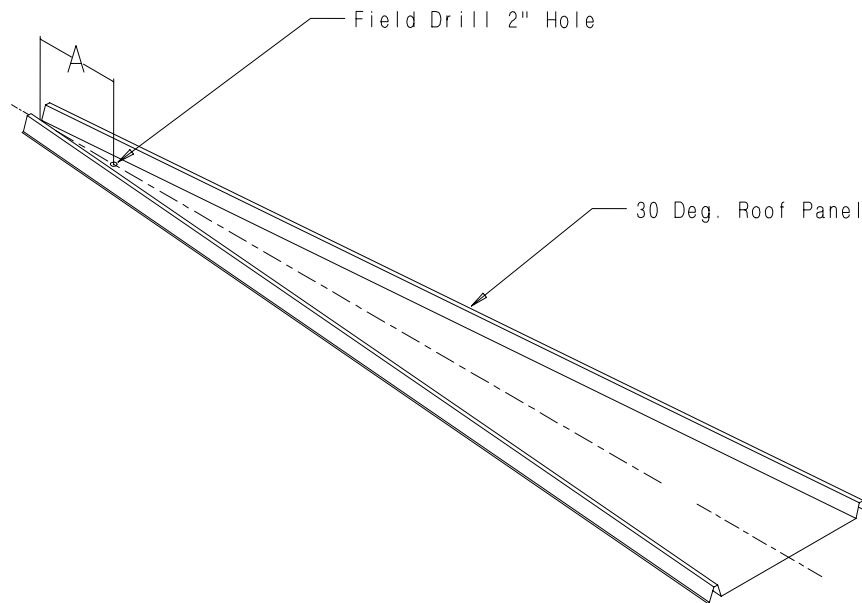

Figure 9

Drying Chamber High-Level Rotary Switch Installation

- 1) Drill a 2" diameter hole through the roof panel at the location shown in figure 8.
See Component placement on page 9 for proper placement in relation to fill auger.
- 2) Assemble 1/4" shaft to rotary switch with 1/4" coupler and rolled pins.
- 3) Screw 1-1/4" pipe coupler to bottom of rotary switch.
- 4) Insert 1-1/4" pipe through adjustable roof mount weldment. Leave 1-1/4" pipe sticking out the top of the weldment 3" as shown in Diagram.
- 5) Install switch assembly through 2" hole in roof.
- 6) Install paddle to 1/4" shaft assembly with coupler and rolled pins.



Top Dry Bin Diameter	"A"
18' - 24'	23.50"
27' & 30'	19.00"

Figure 8

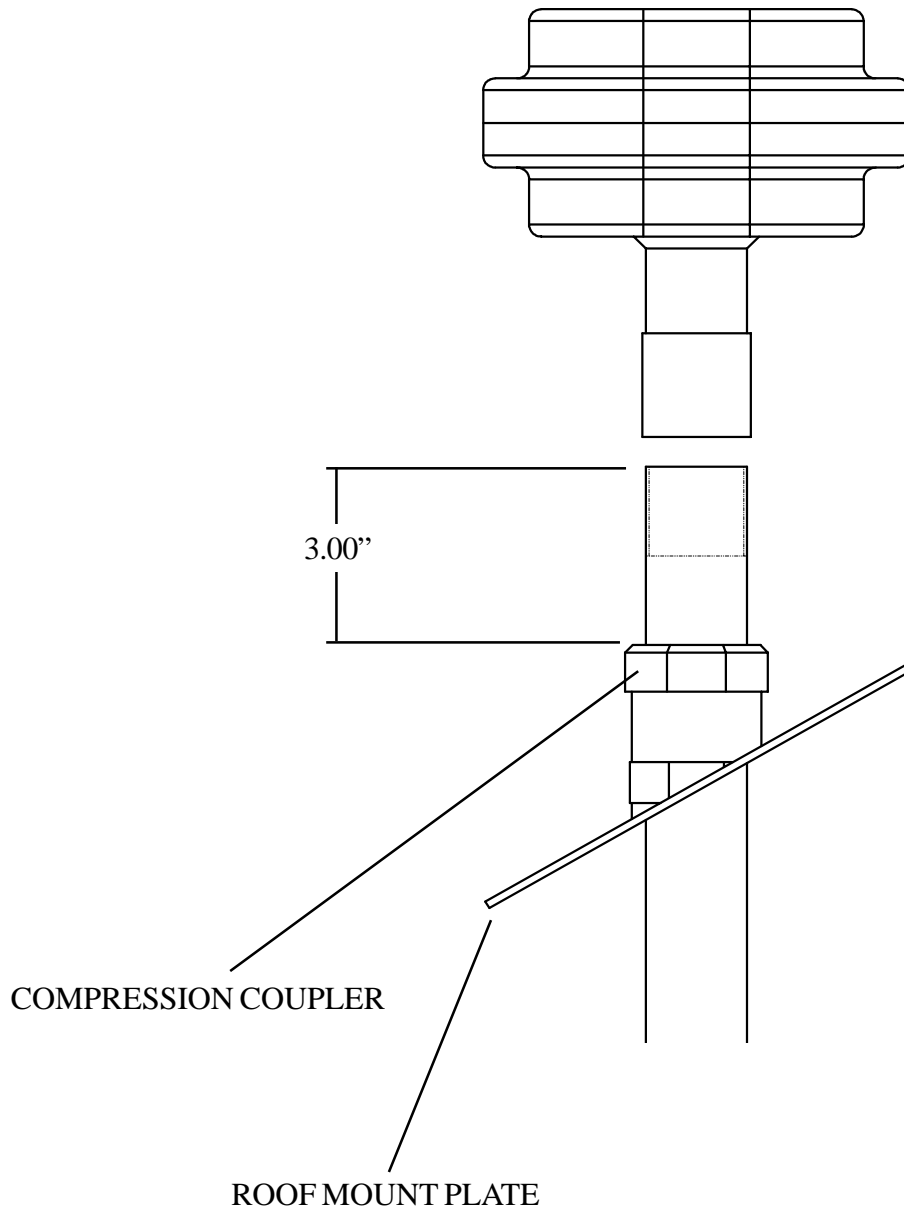

Figure 10

Drying Chamber Overflow Rotary Switch Installation

- 1) Drill a 2" diameter hole through the roof panel at the location shown in figure 8.
See Component placement on page 9 for proper placement in relation to fill auger.
- 2) Use the mounting plate as a pattern and drill four 3/8" holes through the roof panel at the switch location so the plate can be bolted to the roof.
- 3) Attach the flex coupling to the rotary switch power pack using a roll pin.
- 4) Apply teflon tape or pipe sealant (not included) to the rotary switch power pack threads and thread the rotary switch power pack into the mounting plate coupling.
- 5) Make sure that the conduit hole is at right angles with the roof panel ribs or facing towards the eave.
- 6) Caulk the underside of the mounting plate and on all sides of the 2" hole.
- 7) Bolt the assembly to the roof panel.
- 8) Attach the 3-vane paddle to the flex coupling as shown in figure 11.

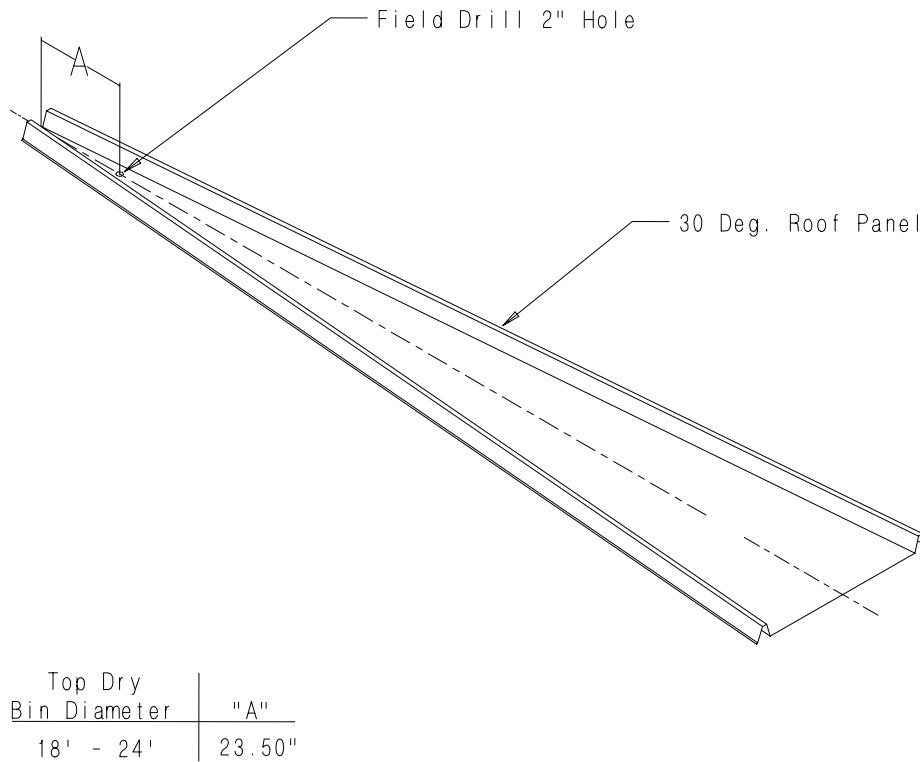

Figure 8

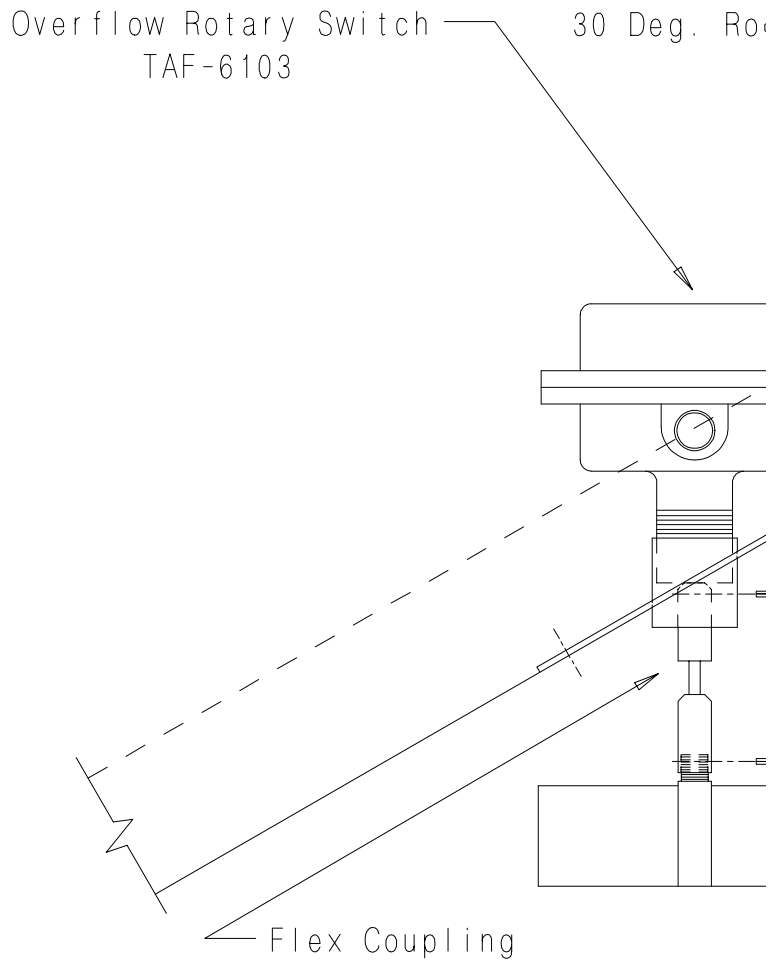

Figure 11

Liquid Propane (LP)

Top Dry dryers have internal vaporizers, and they are designed to operate on liquid draw from the supply tank. Avoid using propane supply tanks that have been used for vapor draw for long periods of time. When using liquid draw systems any moisture that may be present in tanks or lines may freeze when the system is used in cold weather. To avoid this situation, purge the system with methanol. Do not use tanks which have previously been used for ammonia or fertilizer solutions. These substances are extremely corrosive and will damage fuel supply and burner parts. Because the vaporizer coil may need to be adjusted during operation flexible hose suitable for LPs should be used for the final field connection.

See the “Fuel Systems and Rec-

ommendations Chart” for liquid propane to determine the correct size line to run from the tank to the dryer. Have a qualified gas service person inspect the installation to be sure that everything is installed according to local codes and ordinances.

After installation is complete check all connections for leaks with liquid detergent or comparable. Wear rubber gloves and eye protection. Avoid contact with liquid propane. **DO NOT USE FLAME FOR LEAK TESTING.**



LP line field connection.

**Fuel System Specifications and Recommendations
Liquid Propane (LP)**

Dryer Fan Size	Dryer Horsepower	Maximum Heat Capacity BTU Per Hour	Maximum Fuel Flow Gallons Per Hour	Minimum Line Size	Orifice Size	Minimum Operating Pressure	Maximum Operating Pressure
28	10-12	3 million	32	1/2	1/4	1 lb.	15 lbs.
36"	15	5 million	54	1/2"	21/64	1 lb.	15 lbs.
40	15	5.5 million	60	1/2"	11/32	1 lb.	15 lbs.
42"	30	9 million	95	1/2"	.328"	1 lb.	15 lbs.
42"	40	9.5 million	104	3/4"	29/64"	1 lb.	15 lbs.

Natural Gas (NG)

This dryer is designed to operate on natural gas. Natural gas units have a larger orifice to accommodate lower pressures sometimes found with natural gas and do not have vaporizer coils like liquid propane units. A regulated pressure of 10 PSI minimum, 30 PSI maximum must be provided at the field connection point on the fan and heater unit, with gas available in sufficient volume to maintain the operating pressure.

See the “Fuel Systems and Recommendations Chart” for natural gas to determine the correct size line to run to the dryer. Have a qualified gas service person inspect the installation to be sure everything is installed ac-

ording to local codes and ordinances.

After installation is complete check all connections for leaks with liquid detergent or comparable. Wear rubber gloves and eye protection. **DO NOT USE FLAME FOR LEAK TESTING.**



NG line field connection.

**Fuel System Specifications and Recommendations
Natural Gas (NG)**

Dryer Fan Size	Dryer Horsepower	Maximum Heat Capacity BTU Per Hour	Maximum Fuel Flow Cubic Ft. Per Hour	Minimum Line Size	Orifice Size	Minimum Operating Pressure	Maximum Operating Pressure
28	10-12	3 million	2970	1-1/2	3/8	1 lb.	7 lbs.
36	15	5 million	5280	2"	1/2"	1 lb.	7 lbs.
40	15	5.5million	5965	2"	17/32	1 lb.	7 lbs.
42	30	9 million	9536	2"	43/64	1 lb.	7 lbs.
42	40	9.5 million	10445	2"	45/64	1 lb.	7 lbs.

Conduit Runs

Control Wires

Run #1 Autoflow Control Box to Master Fan/Heater Control Box
Five (5)-Control wires 16ga minimum

(NOTE: A shielded two conductor 16ga cable should be used for the network connections.)

Run #2 Autoflow Control Box to Actuator Control Box
Five (5)-Control wires 16ga minimum

Run #3 Autoflow Control Box to Wet Supply Rotary Switch
Four (4)-Control wires 16ga minimum

Run #4 Autoflow Control Box to Storage Chamber Rotary Switch
Five (5)-Control wires 16ga minimum

Run #5 Autoflow Control Box to Drying Chamber Rotary Switches
Six (6)-Control wires 16ga minimum

Run #6 Autoflow Control Box to Fill System Control Box (if applicable)
Eleven (11)-Control wires 16ga min.

Run #7 Master Fan/Heater Control Box to Slave Fan/Heater Control Box
Four (4)-Control wires 16ga minimum
(NOTE: A shielded two conductor 16ga cable should be used for the network connections.)

Run #8 Slave Fan/Heater #1 Control Box to Slave Fan/Heater #2 Control Box
Four (4)-Control wires 16ga minimum
(NOTE: A shielded two conductor 16ga cable should be used for the network connections.)

Power/Motor Wires

Run #1 Entrance Panel to Master Fan/Heater Control Box (for fan motor)

Run #2 Entrance Panel to Slave Fan/Heater Control Boxes (if applicable, for fan motor)

Run #3 Entrance Panel to Fill System Control Box (if applicable)
-For Fill System #1 motor starter
-For Fill System #2 motor starter (if applicable)
-For Aeration fan motor starter

Run #4 Fill System Control Box to Fill System #1 Motor

Run #5 Fill System Control Box to Fill System #2 Motor (if applicable)

Run #6 Fill System Control Box to Aeration Fan Motor

Run #7 Entrance Panel to Actuator Control Box
-110V AC, 110V N, Ground wire for battery charger

Grounding

All Control Boxes should be properly grounded with a ground lug mounted in each control box.

3 million

5 million

Power Supply

An adequate power supply and proper wiring are important factors for maximum performance and long life of the dryer. Electrical service must be adequate enough to prevent low voltage damage to motors and control circuits (see Electrical Load Information on page 40).

Transformer and Wiring Voltage Drop

It is necessary to know the distance from the unit to the available transformer, and the horsepower of your fan unit. Advise the service representative of your local power supplier that an additional load will be placed on the line. Each fan motor should be wired through a fused or circuit breaker disconnect switch. Check on KVA rating of transformers, considering total horsepower load. The power supply wiring, main switch equipment and transformers must provide adequate motor starting and operating voltage. Voltage drop during motor starting should not exceed 14% of normal voltage, and after motor is running at full speed it should be within 8% of normal voltage. Check Electrical Load Information for HP ratings and maximum amp loads to properly size wire and fusing elements. Standard electrical safety practices and codes should be used. (Refer to National Electrical Code Standard Handbook by National Fire Protection Association).

Machine to Earth Grounding

It is very important that a *Machine To Earth Ground Rod* be installed at the fan. This is true even if there is a ground at the pole 15 feet away. Place the ground rod that comes standard, within 8 feet of the dryer and attach it to the dryer control panel with at least a #6 solid, bare, copper ground wire and the clamp provided. The grounding rod located at the power pole will not provide adequate grounding for the dryer. The proper grounding will provide additional safety in case of any short and will ensure long life of all circuit boards,

and the ignition system. The ground rod must be in accordance with local requirements.

Proper Installation of Ground Rod

It is not recommended that the rod be driven into dry ground.

Follow these instructions for proper installation:

1. Dig a hole large enough to hold 1 to 2 gallons of water.
2. Fill hole with water.
3. Insert rod through water and jab it into the ground.
4. Continue jabbing the rod up and down. The water will work its way down the hole, making it possible to work the rod completely into the ground. This method of installing the rod gives a good conductive bond with the surrounding soil.
5. Connect the bare, copper ground wire to the rod with the proper ground rod clamp. See Figure 12.
6. Connect the bare copper ground wire to the fan control boxes with a grounding lug.



7. Ground wire must not have any breaks or splices.

Dig a hole large enough to hold 1 or 2 gallons of water. Work the ground rod into the earth until it is completely in the ground.

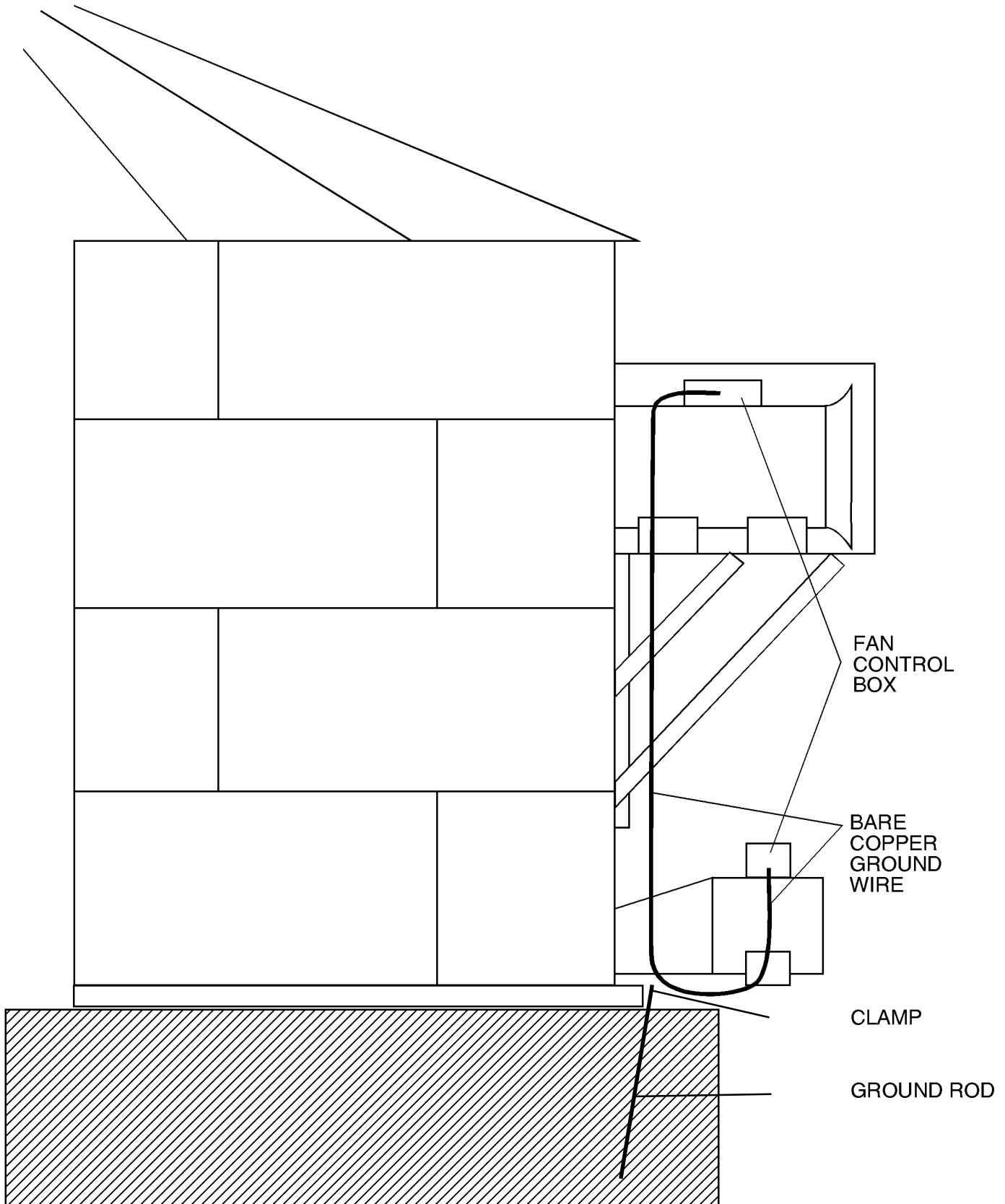

Figure 12: The Top Dry and ground rod attachment illustration.

The Following diagram details the configuration for correct main power installation. Use the diagram in conjunction with the Electrical Load information and Wire Size information provided. The diagram details the correct main power installation for 220V 1 ph, 230V 3 ph, 460V 3ph, 575V 3ph, and 380V 3ph 50hz power supplies.

On all three phase systems put the leg with the highest potential difference between that leg and ground (wild or high voltage leg) on the center terminal (L2) at the motor starter.

NOTE: Standard electrical safety should be used. (Refer to the National Electrical Code Standard Handbook by the National Fire Protection Association). A qualified electrician should make all electrical wiring installations. Follow all local or national electrical safety standards and ordinances when installing the equipment.

Main Power Schematic

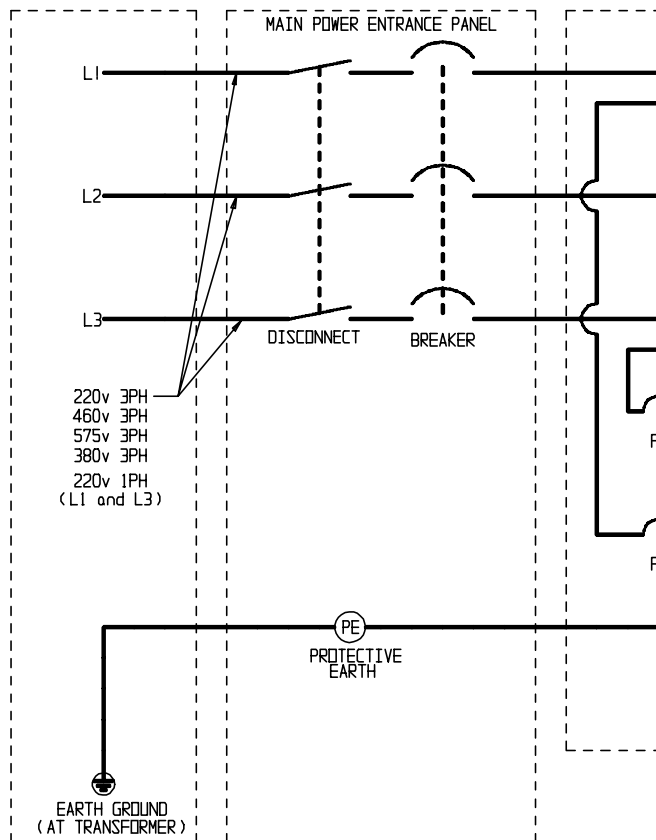

Electrical Load Information

The following charts provide information for the electrician wiring the grain dryer, and are a reference guide for parts. It is recommended that you contact your local power company and have a representatives survey the installation to see that your wiring is compatible with their system and that adequate power is supplied to your unit. Remember that the only thing connected to the recommended service amps should be your grain dryer. Standard electrical safety should be used. (Refer to the National Electrical Code Standard Handbook by the National Fire Protection Association). A qualified electrician should make all electrical wiring installations.

Dryer Fan Size	Voltage	Horsepower	Full Load Amps	Fuse (Slow Blow)	Breaker
	220V1ph	10-12	48	100	100
	208V3ph	10-12	35	80	80
28"	220V3ph	10-12	33	80	80
	380V50hz	10-12	15	40	40
	460V3ph	10-12	17	40	40
	575V3ph	10-12	15	40	40
	220V1ph	10-16	78	150	150
	208V3ph	15	44	125	125
36"	220V3ph	15	39	100	100
	380V50hz	15	27	80	80
	460V3ph	15	20	50	50
	575V3ph	15	16	40	40
	220V1ph	10-16	78	150	150
	208V3ph	15	44	125	125
40"	220V3ph	15	39	100	100
	380V50hz	15	27	80	80

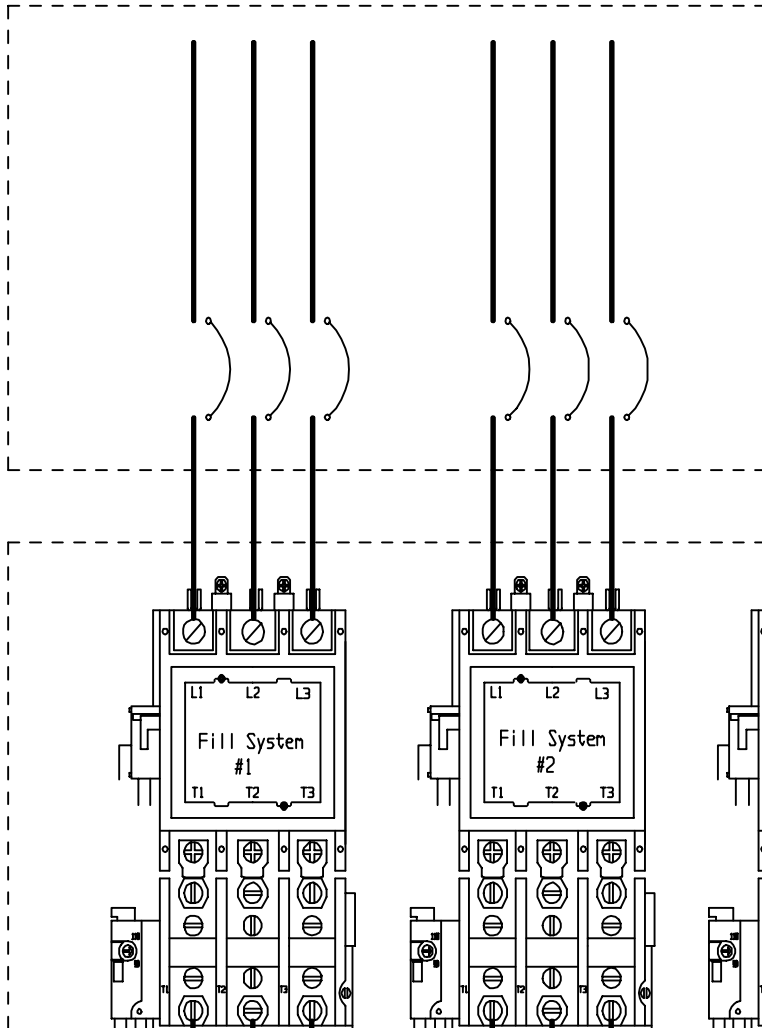

Figure 18

Autoflow to Master Fan/Heater Unit Interconnect

The Master Fan/Heater Unit is the only fan and heater in a single fan unit. In two fan units it is the fan/heater with the airswitch, plenum temperature sensor, and grain temperature sensor connected to it. DO NOT run the control wires for the Master Fan/Heater in the same conduit as the power wires for the fan motor. To wire the Master Fan/Heater Unit to the Autoflow Control Box do the following.

Important!

NOTE: Do NOT use solid wire for interconnections.

NOTE: A shielded 16 gauge cable is recommended for use on the network connection. The network wires for this configuration are attached to terminals number 4 and 5. Ground each end of the shielded cable to the housing. A shielded 16 gauge 2 wire cable can be purchased from GSI. Part # WR-16 / 2S.

- 1) Run five (5) control wires from the Autoflow Control Box to the Master Fan/Heater Unit.
- 2) Connect the wires as shown in figure 19.

Master Fan and Heater Dipswitch Setting : #1 - "Off" / All Others - "On"

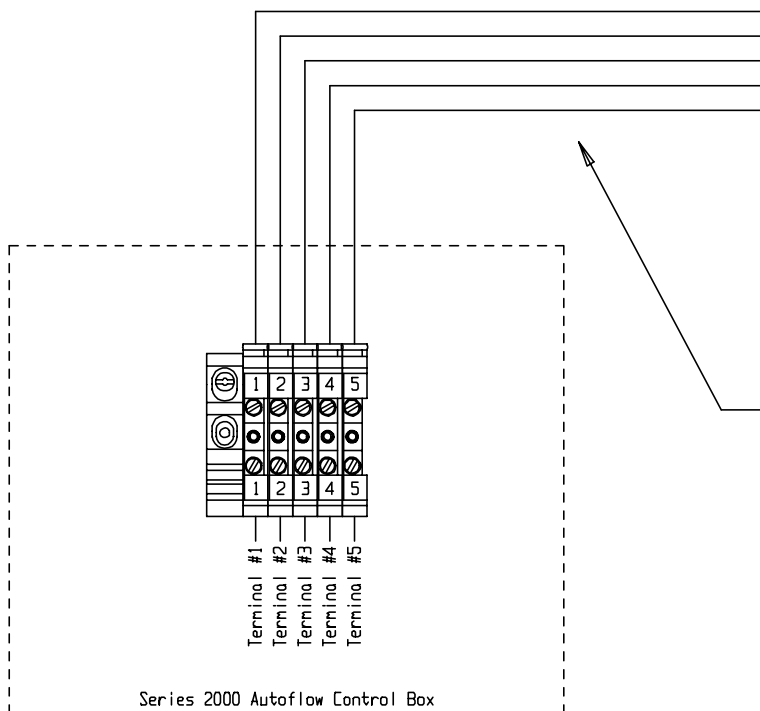

Figure 19

Autoflow to Actuator Interconnect

The Actuator Control Box houses the 24V DC linear actuator, two (2) 12V DC Batteries, and a 24V DC battery charger. The linear actuator raises and lowers the dump chutes to unload grain automatically from the drying chamber to the storage chamber. The two (2) 12V DC batteries act as a backup to prevent wet grain from dumping into the storage chamber during a power outage. The 24V DC battery charger provides a continuous recharge to the batteries.

To wire the Actuator Control Box to the Autoflow Control Box do the following.

- 1) Run five (5) control wires from the Autoflow Control Box to the Actuator Control Box.
- 2) Run three (3) power wires from the Entrance Panel to the Actuator Control Box.
- 3) Connect the wires as shown in figure 20.

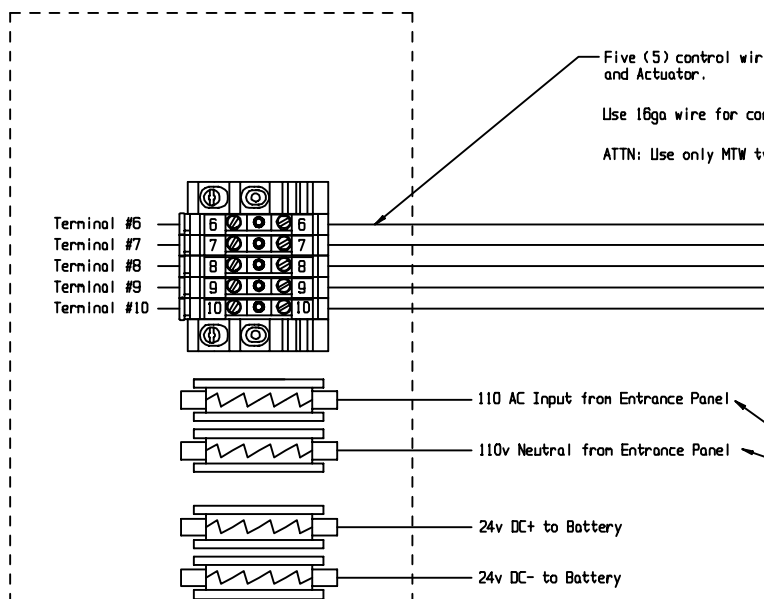

Figure 20

Autoflow to Wet Supply Rotary Switch Interconnect

The 110V AC rotary switch located in the wet storage tank is used to inform the computer on the availability of wet grain. The Wet Supply Rotary Switch use 110V AC to power the motor and 12V DC + to switch a signal back to the computer.

To wire the Wet Supply Rotary Switch to the Autoflow Control Box do the following:

- 1) Run Four (4) control wires from the Autoflow Control Box to the Wet Supply Rotary Switch.
- 2) Connect the wires as shown in figure 21.

Wet Supply Rotary Switch mounted in the side of the wet grain holding tank.

Four (4) control wires between the Autoflow Control Box and the Wet Supply Rotary Switch.

Use 16ga wire for control wires.

ATTN: Use only MTW type wire for control wiring!!

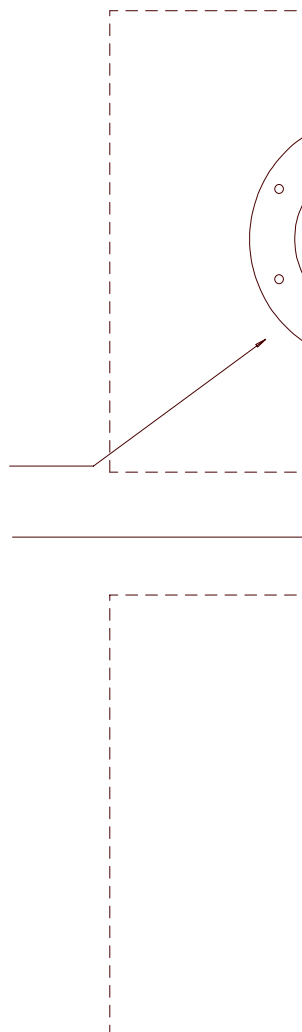

Figure 21

Autoflow to Storage Chamber Rotary Switch Inerconnect

The 110V AC Rotary switch located in the storage tank is used to inform the computer on the availability of wet grain. The Storage Chamber Rotary Switch is mounted three (3) feet below the fan/heater unit(s). The Storage Chamber Rotary Switch use 110V AC to power the motor and 12V DC + to switch a signal back to the computer.

To wire the Storage Chamber Rotary Switch to the Autoflow Control Box do the following:

- 1) Run five (5) control wires from the Autoflow Control Box to the Storage Chamber Rotary Switch.
- 2) Connect the wires as shown in figure 22.

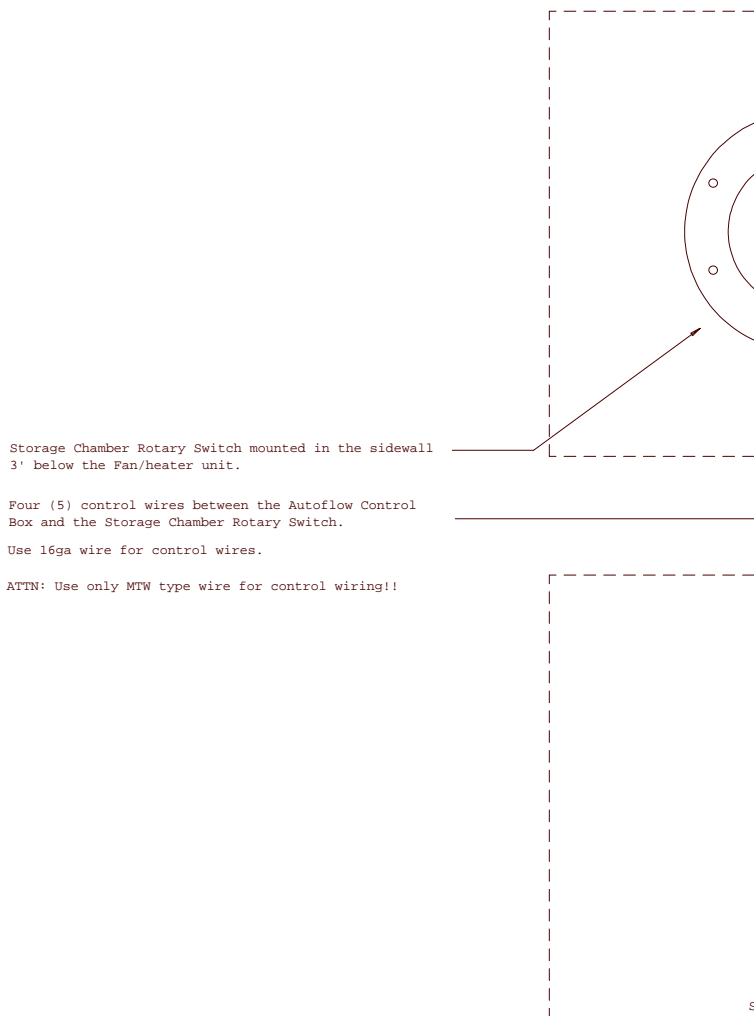

Figure 22

Autoflow to Drying Chamber Rotary Switches Interconnect

The three (3) 110V AC rotary switches located in the drying chamber are used to inform the computer on the location of grain in the drying chamber. The rotary switch with the shortest extension is the Drying Chamber Overflow Rotary Switch. It is used as a safety in the event the Chamber High Level Rotary Switch fails. The rotary switch with the longest extension is the Drying Chamber Low Level Rotary Switch. It is used to inform the computer when the peak has been covered with grain so the drying process can begin; and, will shut the dryer down if the drying chamber empties unexpectedly. The third rotary switch is the Drying Chamber High Level Rotary Switch. It is used to inform the dryer when the drying chamber is full. The Drying Chamber Rotary Switches us 110V AC to power the motor and 12V DC+ to

switch a signal back to the computer. The 110V AC, 110V N, and the 12V DC+ wires can be jumped from rotary switch to rotary switch to lessen the wires needed.

To wire the Drying Chamber Rotary Switches to the Autoflow Control Box do the following:

- 1) Run six (6) control wires from the Autoflow Control Box to the Drying Chamber Rotary Switches.
- 2) Connect the wires as shown in figure 23.

- 1 110 VAC to all Rotary Switches-----RED W BLACK STRIP
- 2 110 VAC Neutral to all Rotary Switches-----RED
- 3 12 VDC Positive from Low Level Rotary Switch-----ORANGE
- 4 12 VDC Positive from High Level Rotary Switch-----BLACK
- 5 12 VDC Positive from Overflow Rotary Switch-----YELLOW
- 6 12 VDC Positive to all Rotary Switchs -----BLUE

Drying Chamber Rotary Switches mounted in the roof.
 Six (6) control wires between the Autoflow Control
 Box and the Drying Chamber Rotary Switches Junction box.
 Use 16ga. wire for control wires.
 ATTN: Use only MTW type wire for control wiring!!!

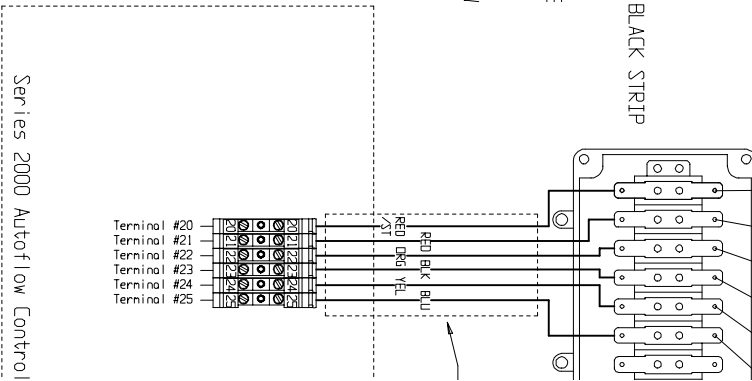

Figure 23

Autoflow to Fill System Control Box Interconnect

The Fill System Control Box houses the starter (s) for the fill system(s) that load grain into the Top Dry Autoflow Unit and for the aeration fan. **DO NOT** run the control wires for the Fill System Control Box in the same conduit used for the power wires for the fill system and aeration fan motors. To wire the Fill System Control to the Autoflow Control Box do the following.

- 1) Run eleven (11) control wires from the Autoflow Control Box to the Fill System Control Box.
- 2) Connect the wires as shown in figure 24.

Eleven (11) Control Wires between the Autoflow Control Box and the Fill System Control Box

Use 16ga wire for control wires.

ATTN: Use only MTW type wire for control wiring!!

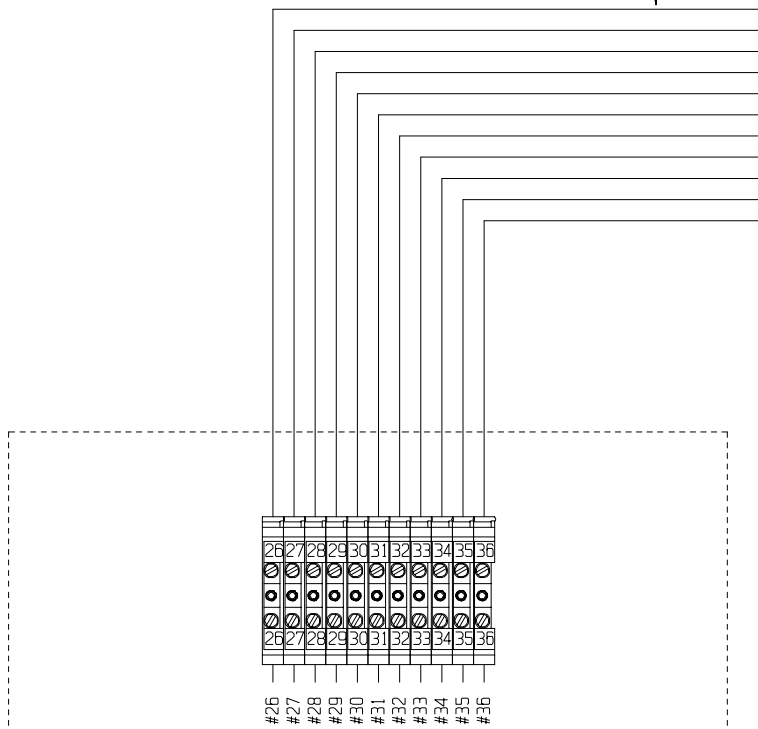

Figure 24

Autoflow to Ground Interconnect

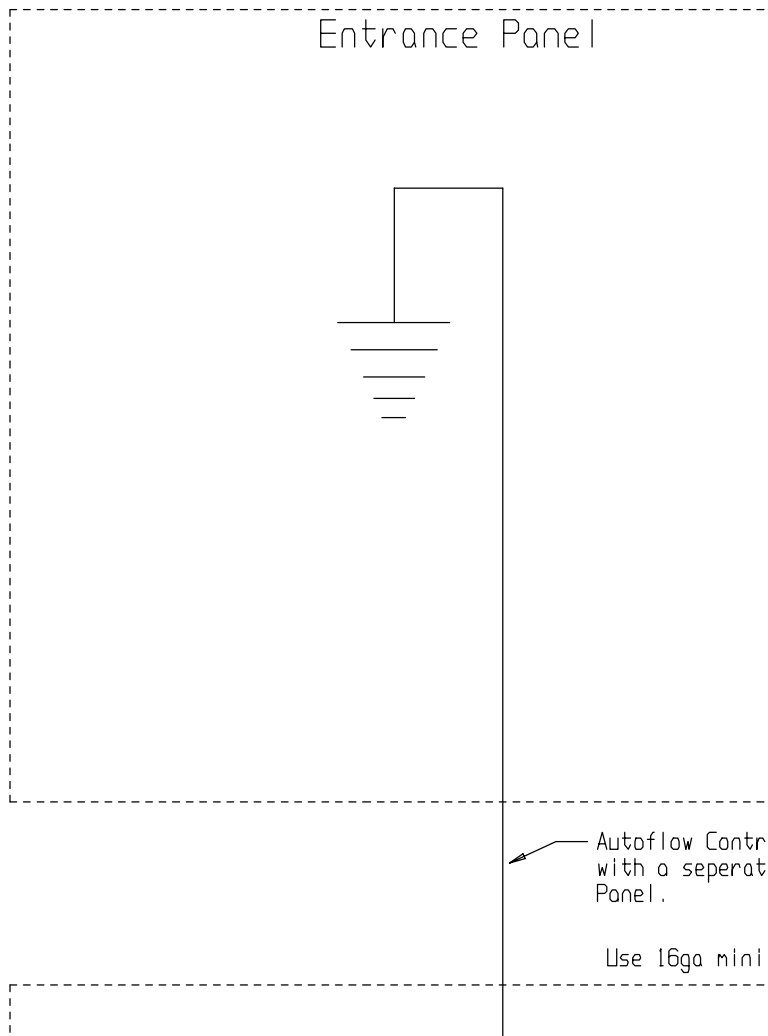

Figure 25

Master to Slave Interconnect

A slave fan/heater unit can be added to operate in unison with the master fan/heater unit. The interconnect between the master and slave fan/heater units remains the same regardless of the type or presence of a control center. To wire a slave fan/heater unit to a master fan/heater unit do the following:

NOTE: Do NOT use solid wire for interconnection.

1. Run four (4) 16ga MTW type wires from the master fan/heater unit to the slave fan/heater unit.
2. Connect the wires as shown in figure #26.

NOTE: A shielded 16 gauge cable is recommended for use on the network connections. The network connections for this configuration are attached to terminals number 8 and 9 in the master unit and terminals number 3 and 4 in the slave unit. Ground each end of the shielded cable to the housing. A shielded 16 gauge 2 wire cable can be purchased from GSI. Part # WR-16/ 2S.

**Slave #1 Fan and Heater Dipswitch Setting :
#2 - "Off" / All Others - "On"**

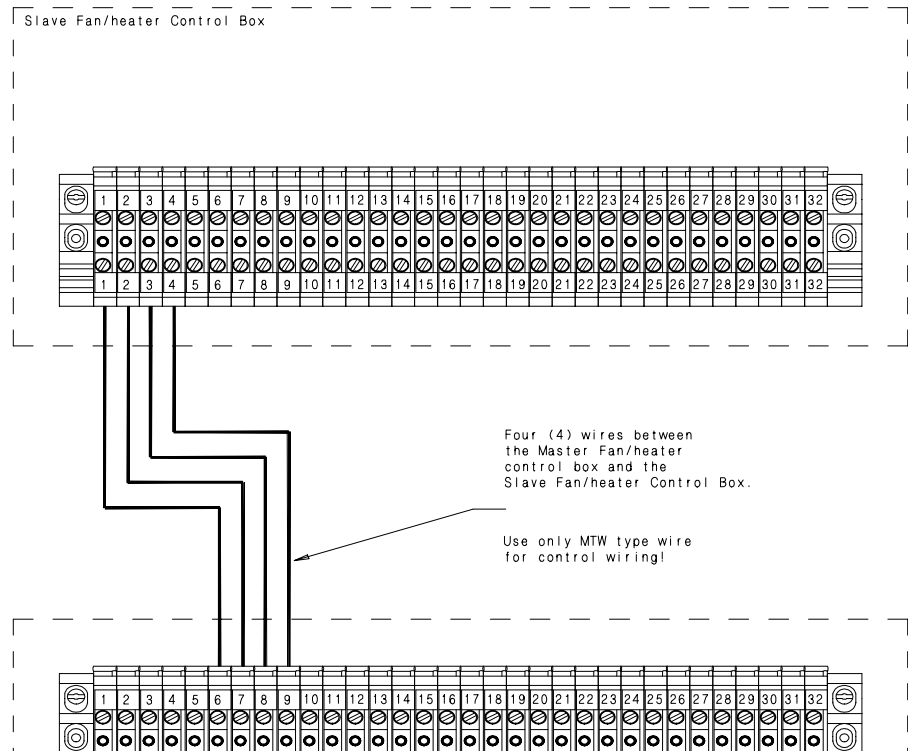

Figure 26: Wiring for a slave fan/heater unit to a master fan/heater unit.

Slave to Slave Interconnect

A second slave fan/heater unit can be added to operate in unison with the master fan/heater unit and another slave fan/heater unit. This would create a three fan unit. The interconnect between the first slave fan/heater unit and the second slave fan/heater unit remains the same regardless of the type or presence of a control center. To wire a second slave fan/heater unit to another slave fan/heater unit do the following:

NOTE: Do NOT use solid wire for inter-connection.

1. Run four (4) 16ga MTW type wires from the first slave fan/heater unit to the second slave fan/heater unit.
2. Connect the wires as shown in figure #27.

NOTE: A shielded 16 gauge cable is recommended for use on the network connections. The network connections for this configuration are attached to terminals number 7 and 8 in slave #1 and terminals number 3 and 4 in slave #2. Ground each end of the shielded cable to the housing. A shielded 16 gauge 2 wire cable can be purchased from GSI. Part #WR-16 / 2S

Slave #2 Fan and Heater Dipswitch Setting :
#1 and #2 - "Off" / All Others - "On"

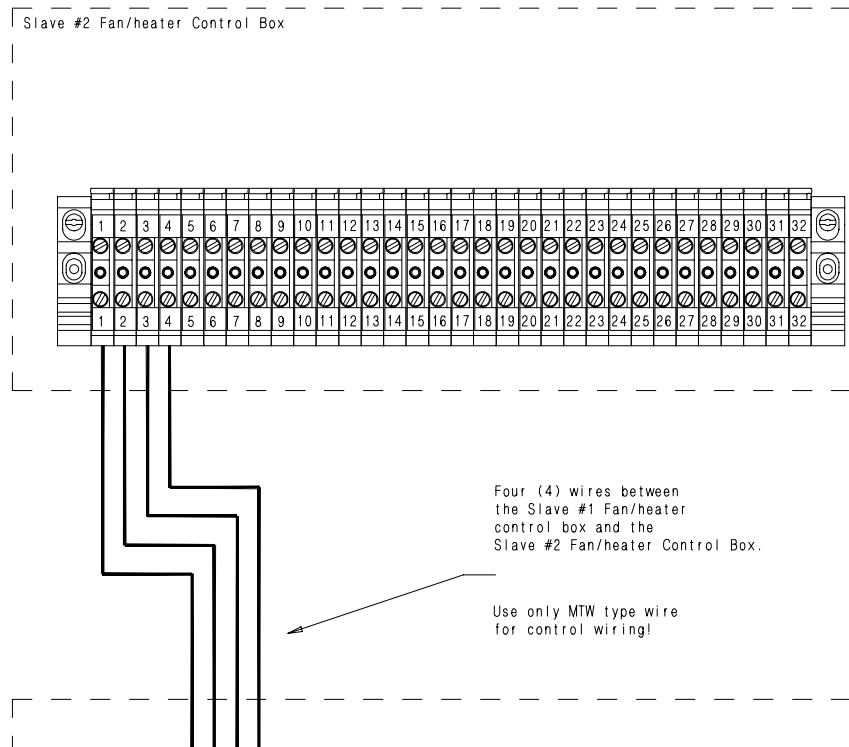

Figure 27: Wiring for a second slave fan/heater unit to another slave fan/heater unit.

Battery Hook-Up

Two (2) lawn and garden type 12V DC Batteries are required for proper operation of the Actuator Control Box. The two (2) 12V DC batteries are wired in series to provide the 24V DC linear actuator with the voltage required to operate. The two (2) 12V DC batteries should be mounted on the shelves provided in the Actuator Control Box.

To wire the two (2) 12V DC batteries to the 24V DC battery charger do the following:

- 1) Mount the two (2) 12V DC batteries in the Actuator Control Box on the proper shelves.
- 2) Install a jumper from the negative terminal on one battery to the positive

terminal on the other battery.

- 3) Attach the red wire coming from the fuse block and the positive lead on the 24V DC battery charger to the open positive terminal on one battery.
- 4) Attach the black wire coming from the fuse block; and the negative lead on the 24V DC battery charger to the open negative terminal on the other battery.
- 5) Use Figure 28 to guide installation.

**12 VOLT BATTERIES ARE NOT SUPPLIED BY GSI.
MOUNT BATTERIES ON BATTERY SHELVES IN
24 VOLT CHARGER SHOULD HOOK UP TO POS AND N**

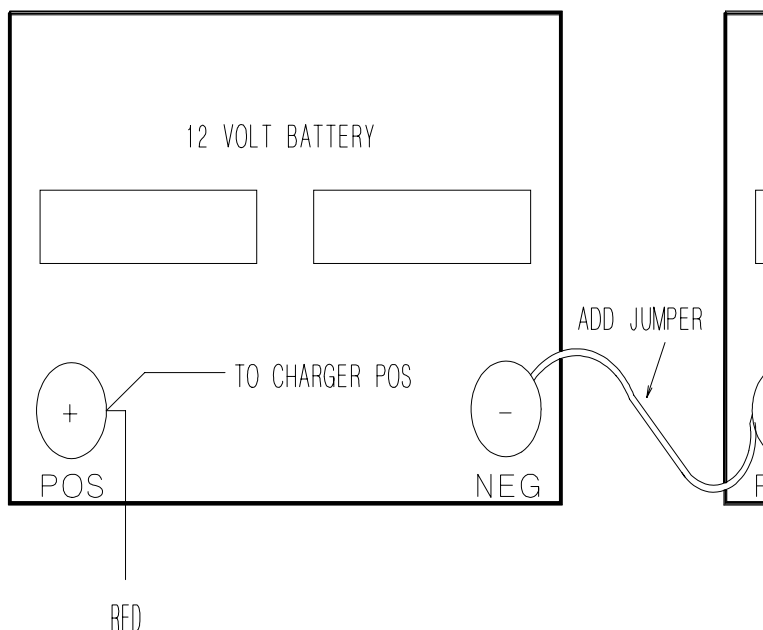

Figure 28

Dump Chute Cable Installation

After complete installation of the Autoflow Unit the cable should be hooked up to the linear actuator in the Actuator Control Box. To test the linear actuator and install the cable do the following:

- 1) Turn all switches on the Autoflow control front panel to the “off” position.
- 2) Make sure the Emergency Stop switches on all the control boxes are pulled out.
- 3) Turn the Control Power switch to the “on” position.
- 4) The display should read “stopped” at the bottom.
- 5) While watching the linear actuator turn the Dump switch to the “manual open” position.
- 6) The Linear actuator should extend down 16”.
- 7) Place the Dump switch in the “auto” position and press the Stop switch.
- 8) The linear actuator should retract and stop.
- 9) Place the Control Power switch in the “off” position and push the Emergency stop switch in on the Autoflow and Actuator Control Boxes.
- 10) Route the cable as shown in figure 29.
- 11) Make sure that all dump chutes are approximately 5 degrees below level when in the closed position.
- 12) Double check all dump chutes to make sure that they are all adjusted the same when in the closed position. The Autoflow Unit will not operate properly if the dump chutes are adjusted unevenly.

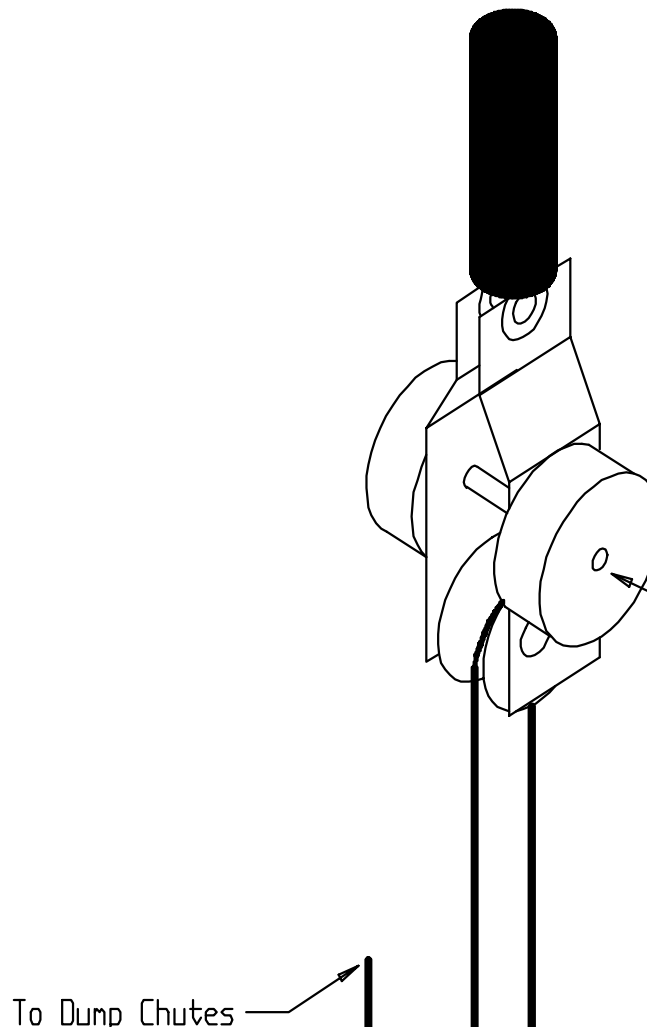

Figure 29

THE GSI GROUP, INC. ("GSI") WARRANTS ALL PRODUCTS MANUFACTURED BY GSI TO BE FREE OF DEFECTS IN MATERIAL AND WORKMANSHIP UNDER NORMAL USAGE AND CONDITIONS FOR A PERIOD OF TWELVE MONTHS AFTER RETAIL SALE TO THE ORIGINAL END USER OF SUCH PRODUCTS. GSI'S ONLY OBLIGATION IS, AND PURCHASER'S SOLE REMEDY SHALL BE FOR GSI, TO REPAIR OR REPLACE, AT GSI'S OPTION AND EXPENSE, PRODUCTS THAT, IN GSI'S SOLE JUDGMENT, CONTAIN A MATERIAL DEFECT DUE TO MATERIALS OR WORKMANSHIP. ALL DELIVERY AND SHIPMENT CHARGES TO AND FROM GSI'S FACTORY WILL BE PURCHASER'S RESPONSIBILITY. EXPENSES INCURRED BY OR ON BEHALF OF THE PURCHASER WITHOUT PRIOR WRITTEN AUTHORIZATION FROM AN AUTHORIZED EMPLOYEE OF GSI SHALL BE THE SOLE RESPONSIBILITY OF THE PURCHASER.

EXCEPT FOR THE ABOVE STATED EXPRESS LIMITED WARRANTIES, GSI MAKES NO WARRANTY OF ANY KIND, EXPRESSED OR IMPLIED, INCLUDING, WITHOUT LIMITATION, WARRANTIES OF MERCHANTABILITY OR FITNESS FOR A PARTICULAR PURPOSE OR USE IN CONNECTION WITH (i) PRODUCT MANUFACTURED OR SOLD BY GSI OR (ii) ANY ADVICE, INSTRUCTION, RECOMMENDATION OR SUGGESTION PROVIDED BY AN AGENT, REPRESENTATIVE OR EMPLOYEE OF GSI REGARDING OR RELATED TO THE CONFIGURATION, INSTALLATION, LAYOUT, SUITABILITY FOR A PARTICULAR PURPOSE, OR DESIGN OF SUCH PRODUCT OR PRODUCTS.

IN NO EVENT SHALL GSI BE LIABLE FOR ANY DIRECT, INDIRECT, INCIDENTAL OR CONSEQUENTIAL DAMAGES, INCLUDING, WITHOUT LIMITATION, LOSS OF ANTICIPATED PROFITS OR BENEFITS. PURCHASER'S SOLE AND EXCLUSIVE REMEDY SHALL BE LIMITED TO THAT STATED ABOVE, WHICH SHALL NOT EXCEED THE AMOUNT PAID FOR THE PRODUCT PURCHASED. THIS WARRANTY IS NOT TRANSFERABLE AND APPLIES ONLY TO THE ORIGINAL PURCHASER. GSI SHALL HAVE NO OBLIGATION OR RESPONSIBILITY FOR ANY REPRESENTATIVE OR WARRANTIES MADE BY OR ON BEHALF OF ANY DEALER, AGENT OR DISTRIBUTOR OF GSI.

GSI ASSUMES NO RESPONSIBILITY FOR FIELD MODIFICATIONS OR ERECTION DEFECTS WHICH CREATE STRUCTURAL OR STORAGE QUALITY PROBLEMS. MODIFICATIONS TO THE PRODUCT NOT SPECIFICALLY COVERED BY THE CONTENTS OF THIS MANUAL WILL NULLIFY ANY PRODUCT WARRANTY THAT MIGHT HAVE BEEN OTHERWISE AVAILABLE.

THE FOREGOING WARRANTY SHALL NOT COVER PRODUCTS OR PARTS WHICH HAVE BEEN DAMAGED BY NEGLIGENT USE, MISUSE, ALTERATION OR ACCIDENT. THIS WARRANTY COVERS ONLY PRODUCTS MANUFACTURED BY GSI. THIS WARRANTY IS EXCLUSIVE AND IN LIEU OF ALL OTHER WARRANTIES EXPRESS OR IMPLIED. GSI RESERVES THE RIGHT TO MAKE DESIGN OR SPECIFICATION CHANGES AT ANY TIME.

PRIOR TO INSTALLATION, PURCHASER HAS THE RESPONSIBILITY TO RESEARCH AND COMPLY WITH ALL FEDERAL, STATE AND LOCAL CODES WHICH MAY APPLY TO THE LOCATION AND INSTALLATION



a division of

THE GSI GROUP



1004 E. Illinois St.
Assumption, IL 62510
Phone 217-226-4421
Fax 217-226-4498

May 2003