

SAFETY
INSTALLATION
OPERATION
MAINTENANCE



M A N U A L

Bucket Elevator

No. PC522142-C4
Revised 2010-01-15

9575 N. 109th Ave.
Omaha, Nebraska 68142
(402) 330-1500
www.intersystems.net

TABLE OF CONTENTS

I. Safety Information.....	3
II. Installation & Startup.....	5
2.1 Receiving Inspection.....	5
2.2 Pre-installation Preparation.....	5
2.2.1 Elevator Foundation.....	5
2.2.2 Elevator Guying Or Bracing	6
2.2.3 Elevator Intake.....	7
2.2.4 Elevator Discharge	8
2.2.5 Positioning Trunk Sections For Ladder.....	8
2.2.6 Elevator Belt Selection.....	8
2.3 Elevator Erection (Assembly)	9
2.3.1 Vertical Assembly	9
2.3.2 Belt And Bucket Installation	17
2.3.3.1 Belt/Bucket Installation	19
2.3.3.1.1 Method 1; Simultaneous Belt And Bucket Installation;(Less than 100 Ft)	21
2.3.3.1.2 Method 2; Belt Only With Buckets Attached After Splicing Belt.....	22
2.3.4 Belt Splicing	23
2.3.5 Hood Installation	23
2.3.6 Drive Installation	23
2.3.7 Initial Belt Tracking (See Figure 2.15)	24
2.3.8 Rubber Throat Slide Adjustment.....	28
2.3.9 In-Service Belt Tension.....	28
2.3.10 Elevator Bucket Filling	29
III. Maintenance	32
3.1 General Maintenance	32
3.2 General Housekeepingand Periodic Inspection.....	32
3.3 Lubrication	34
3.3.1 Reducer	34
3.3.2 Motor.....	34
3.3.3 Head & Boot Shaft Bearings.....	34
3.3.4 Roller Chain Drive.....	34
3.3.5 Sleeve Guides And Shafts.....	34
3.4 Adjustment and Repair Procedure.....	34
3.4.1 Elevator Belt Tension.....	34
3.4.1.1 Boot Takeup (Belt Tension) Adjustment.....	34
3.4.1.2 Drive V-Belt (If Installed).....	35
3.4.2 Belt Tracking.....	35
3.4.3 Belt Splicing	35
3.4.4 Throat Slide Adjustment	35
3.4.5 Roller Chain Tension	35
IV. Spare Parts.....	36
4.1 Scope.....	36
4.2 Ordering Parts	36
V. Warranty.....	36

I. Safety Information



SAFETY FIRST! The symbols shown above identify examples of the safety labels and signs to be found on InterSystems equipment. They are affixed to the equipment to warn of danger to persons and of possible equipment damage. These signs must never be removed, tampered with, painted over or obscured in any way. **(see Page 4 for label locations)**. If labels are damaged or become unreadable, replacement labels are available from InterSystems. User must institute a continuing program to instruct all personnel in safe operating and maintenance procedures and to insure that all safety devices, guards, and covers are intact and operable and that all safety signs are legible.

DO NOT exceed the elevator's rating. A certified drawing or drawings furnished with the elevator gives its capacity in BPH (Bushels Per Hour) plus the weight per cubic foot and the weight per bushel of the commodity or material the elevator is designed to elevate. The drawing also specifies the operating speed of the elevator belt and other pertinent data. Consult InterSystems. before making any changes to the elevator or its operating environment; in particular, any change in the speed or power of the elevator drive. **CARELESS CHANGES COULD RESULT IN DEATH OR SERIOUS INJURY TO PEOPLE, AND/OR REDUCE THE PERFORMANCE AND SERVICE LIFE OF THE EQUIPMENT.**

NEVER PERFORM ANY SERVICE ON THIS ELEVATOR OR ANY OTHER POWERED EQUIPMENT UNTIL ALL POWER HAS BEEN SHUT OFF AND LOCKED OUT SO THAT IT CANNOT BE RESTORED WITHOUT THE CONSENT AND KNOWLEDGE OF THE PERSON WHO INTERRUPTED POWER. Power includes electrical, fluid, mechanical (cable, belt, chain, shaft, etc.), or gravity where the load or part of the equipment is suspended. **NEVER ADD RESTRAINT TO AN EXPLOSION VENT! IF THE ELEVATOR STRUCTURE IS DAMAGED TO THE EXTENT THE RELIEF PANELS WILL NOT STAY IN POSITION, MAKE PROPER REPAIRS!** Remember the vents are designed to blow out readily, limiting damage and injury, in case of explosion. **FAILURE TO OBSERVE ALL SAFETY PRECAUTIONS, INCLUDING THOSE DICTATED BY ORDINARY COMMON SENSE, CAN RESULT IN DEATH OR SERIOUS INJURY TO PERSONNEL, LOSS OF PRODUCT (elevated material), AND DAMAGE OR DESTRUCTION OF THE EQUIPMENT!**

NOTE: THESE LABELS MUST NEVER BE REMOVED, TAMPERED WITH, PAINTED OVER, OR OBSCURED IN ANY WAY. IF LABELS ARE DAMAGED OR BECOME UNREADABLE, REPLACEMENT LABELS ARE AVAILABLE FROM INTERSYSTEMS.

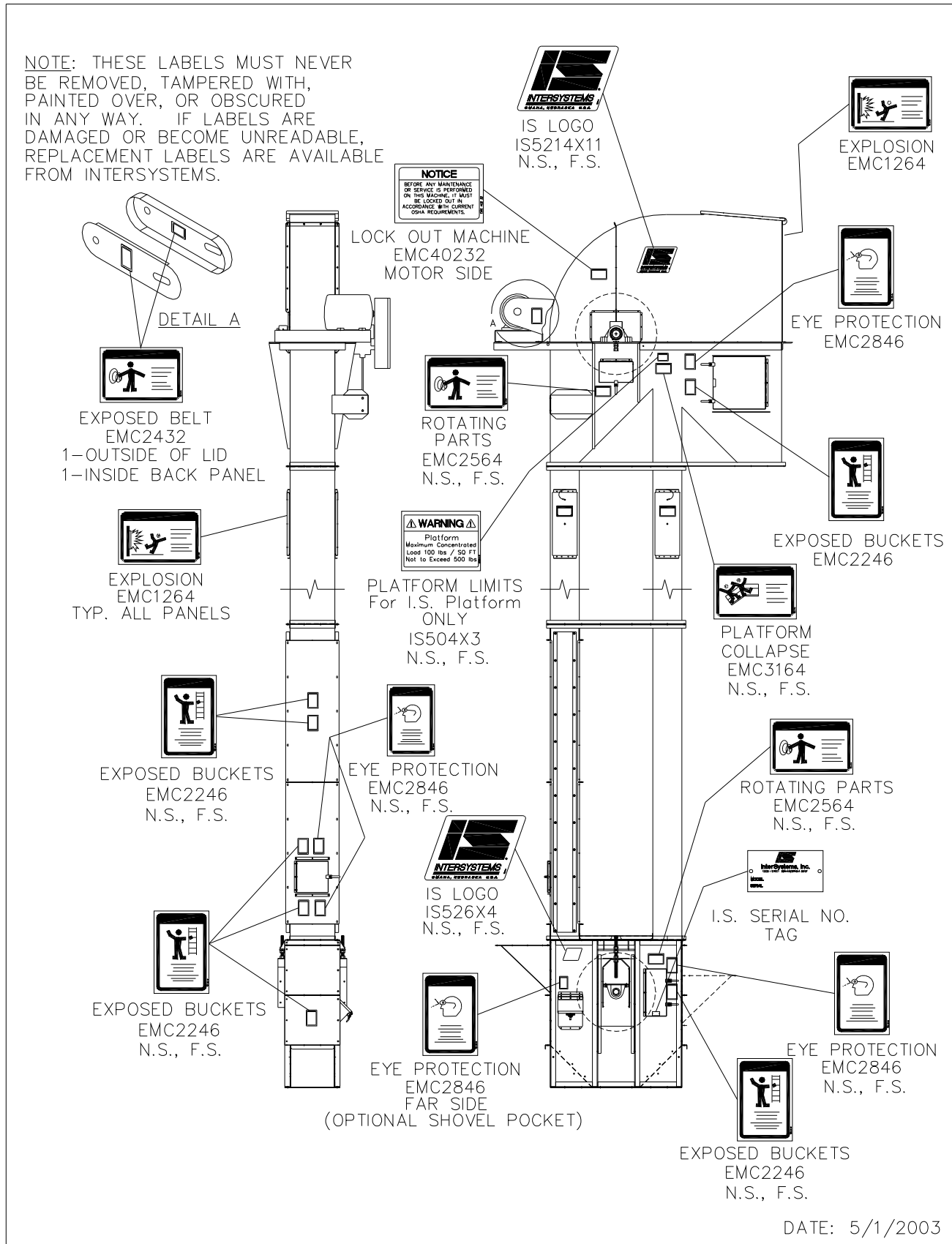

Figure 1-2, Safety Label Location

II. Installation & Startup

NOTICE

Thoroughly read Section I, regarding safety information before beginning installation and startup.

2.1 Receiving Inspection

Carefully inspect the shipment for damage as soon as it is received. Verify that the quantity of parts or packages actually received corresponds to the quantity shown on the packing slip. One or more cartons containing the fasteners required for assembly are included with the shipment. Report any damage or shortage to the delivering carrier as soon as possible. InterSystems' responsibility for damage to the equipment ended with acceptance by the delivering carrier. Refer to the bill of lading. Save all paperwork and documentation furnished with any of the elevator components.

2.2 Pre-installation Preparation

Before starting elevator installation, review this manual, the certified drawing(s) furnished with the equipment, and other applicable documents, including but not limited to, OSHA Regulations and the National Electrical Code. You should also obtain a copy of "Guidelines for Supporting Outside Elevator Legs", Bulletin No. F-646-75, available from Mill Mutual Fire Prevention Bureau, North Riverside Plaza, Chicago, IL 60606, as it is referenced throughout the manual.

InterSystems Bucket Elevators are designed to be vertically self-supporting when erected. The elevator does not require guying and/or bracing from another structure for horizontal support. The elevator has not been designed to support other equipment such as cleaners, distributors, spouting, etc. Separate structures must be provided for any accessory equipment.



InterSystems is the vendor of the elevator and certain of its optional accessories only, and does not assume responsibility for the installation. The installation recommendations contained within this manual are for consideration only. The user or installer will want to consult a civil or structural engineer regarding the design, construction, and supervision of the entire installation, including the elevator foundation and the guying cable and/or bracing system. The **MOST IMPORTANT** preparations are retaining a licensed engineer to plan the installation and a qualified millwright or contractor to erect the elevator and the accompanying equipment and structures.

2.2.1 Elevator Foundation

Refer to Mill Mutual Publication No F-646-75. Additionally, in the process of leveling the boot, InterSystems recommends that the installer plan on shimming the boot around its perimeter and grouting the base plate after the hold down fasteners are in place and tightened.

2.2.2 Elevator Guying or Bracing

Refer to Mill Mutual Publication No F-646-75.

**DANGER**

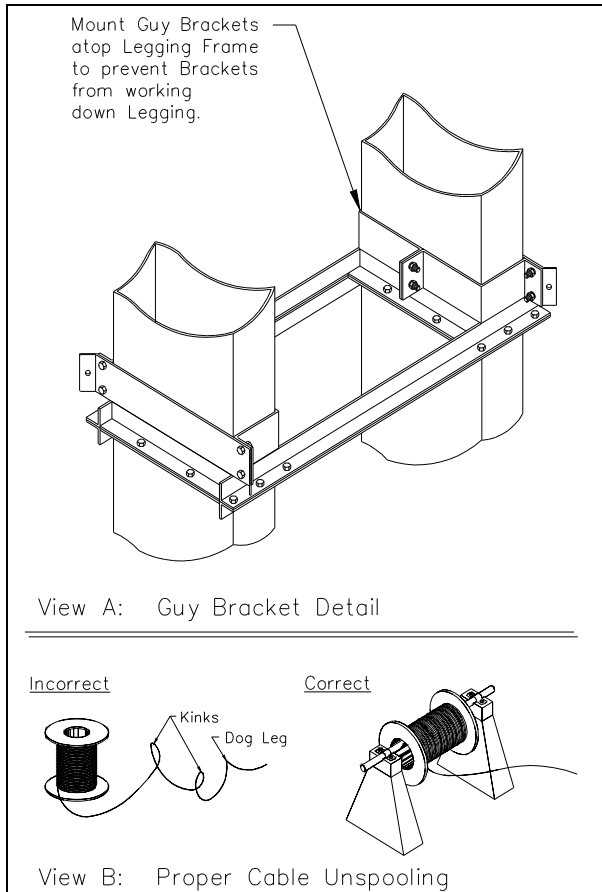

INCORRECT ATTACHMENT OF GUYING CABLES TO ELEVATOR OR BRACING FROM AN ADJOINING STRUCTURE WILL RESULT IN SUPPORT FAILURE, COLLAPSE OF THE ELEVATOR AND DEATH OR SEVERE INJURY TO ANYONE IN THE AREA. ATTACH GUYING CABLES TO THE ELEVATOR ONLY BY MEANS OF THE 4-WIRE BOLT-ON BRACKETS AS SHOWN IN **FIGURE 2-1. IF BRACING FROM AN ADJOINING STRUCTURE IS USED, ATTACH ONLY AT FLANGE JOINTS BETWEEN LEGGING SECTIONS.**



NEVER attach any bracing directly to the sheet metal trunk. Sheet metal lacks the necessary stiffness and thickness for sound structural joints.

The engineer or contractor supervising elevator installation is ultimately responsible for determining suitable guying and/or bracing methods and materials. The following considerations are presented in addition to those set forth in **Mill Mutual Publication No F-646-75**:

- A. Consider placing curbs or guards around anchors to prevent impact and damage from area traffic.
- B. Guy cables near ground level must be guarded and made visible to prevent injuries.
- C. **Figure 2-1, View B** shows the proper method for unspooling cable from a reel.

**DANGER**

EXCESSIVE GUY CABLE TENSION WILL TWIST, BEND AND/OR COLLAPSE THE ELEVATOR STRUCTURE, CAUSING SEVERE INJURY OR DEATH. MAINTAIN PROPER GUY CABLE TENSION AT ALL TIMES.

Figure 2-1, Miscellaneous Guying & Bracing Details

2.2.3 Elevator Intake

Several factors should be taken into account when planning the intake to feed material into the elevator:

- A. The method and location of intake openings in the boot usually will have been determined when the elevator was ordered. However, if the intake arrangements have or are being changed, several factors must be considered. See **Figure 2-2**
 - 1. **Inlet or Hopper Size:** The size of the inlet effects the capacity and the condition of the elevated material. Too small an inlet means the material must be fed into the boot at excessive speed. The excess velocity of incoming material cause damage, the buckets do not fill properly, and material backs up in the boot, clogging the inlet.

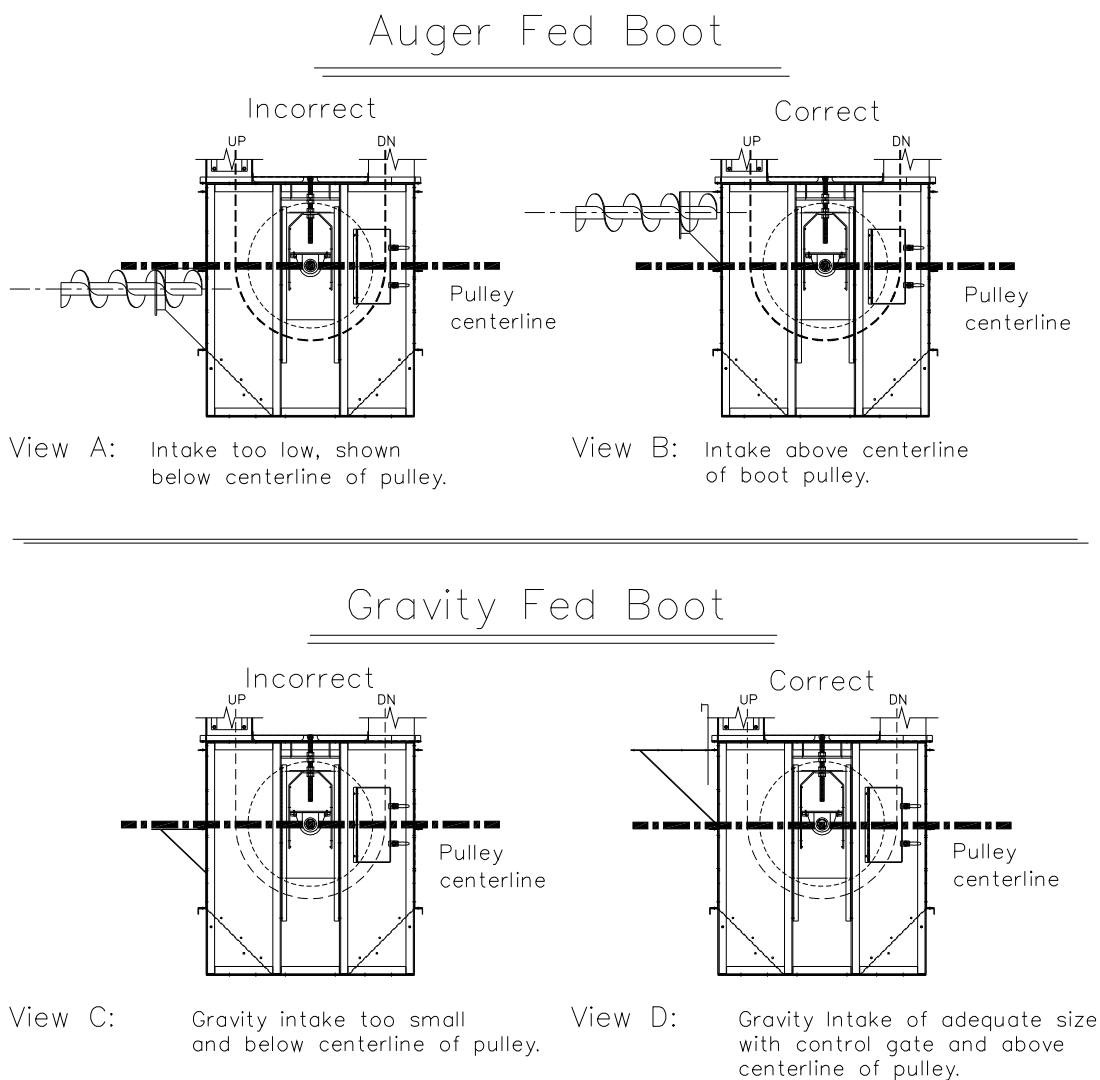

Figure 2-2, Boot Intake Conditions

2. **UP Side Infeed Devices:** The device which feeds the elevator, (auger, belt conveyor, spout, hopper, etc.), must feed the material into the boot ABOVE the centerline of the pulley. The buckets must complete the turn around the pulley and be moving vertically upward, not at a tangent, before encountering material to be elevated. If the buckets ARE NOT moving vertically upward when they encounter the incoming material, material will be forced back into the infeed device or chute. Grinding and churning in the boot area will damage the product and excessive power will be required to operate the system.
3. **DOWN Side Infeed Devices:** Several factors, most importantly the nature of the material being elevated, are important in determining the location of down side or down leg infeed devices. If a change in infeed arrangement from that shown on the certified drawings is contemplated, consult InterSystems before proceeding with modifications.
4. **FLOW of material to the infeed Devices:** Every effort should be made when designing the feeding equipment or spouting such that the direction of the flowing material will be perpendicular to the buckets. Reduce or eliminate any side loading of the buckets. Achieving the bucket elevators rated capacity is determined by even and consistent bucket fill.

2.2.4 Elevator Discharge

- A. Spouting to carry off the material must be sized so that its capacity equals or exceeds the maximum capacity of the elevator to prevent material plugging in the head or downlegging.
- B. The elevator IS NOT designed to support the weight of any accessory equipment. Spouting, cleaners, distributors, etc. must have their own supporting structures.

2.2.5 Positioning Trunk Sections for Ladder

Study the drawings to determine where each trunk section fits into the overall layout of the elevator leg. This is important so that platforms and ladders can be attached to the elevator without having to reassemble ladder brackets. The final ladder at the head section (at the top of the elevator) must be near the trunk closest to the discharge (the down-leg trunk). **See Figure 2-6 for ladder and cage assembly details.**

2.2.6 Elevator Belt Selection

If InterSystems has supplied the belt, no further action is required at this time. However, if the belt is being obtained independent of the elevator, those ordering the belt must be aware of a number of requirements.

- A. Belt length must take into consideration the method of belt splicing to be employed in this installation. Refer to Paragraph 2.3.4 and **See Figure 2-10** for an overview of the three splicing methods commonly employed in elevator installations. A mechanical splice requires the least extra belt while a butt splice requires the greatest length of extra belt.
- B. The pattern, spacing, and size of prepunched holes must be correct for the number, type, and size of the buckets to be attached to the belt. If the belt is purchased with the wrong hole pattern, it will be extremely difficult and expensive to correct the problem in the field. If the hole sizes are too small, they may have to be redrilled in the field. If the holes are too large, the buckets may have to be redrilled to accept larger bolts or be replaced. Elevator bolts must fit snugly in the belt.
- C. The installer should fabricate spreader bars in advance to avoid delay once belt installation begins. **See Figure 2-10, View D.**
- D. A belt manufacturer or a local belt supplier sales representative can assist in the correct selection and specification of belting and advise in proper installation procedures.

2.3 Elevator Erection (Assembly)

Erection of the elevator must not be started until the concrete foundation and the guying anchors (if any are needed) have been completed and developed maximum strength.

NOTICE

NO MATTER WHO DOES THE INSTALLATION OR WHAT METHOD IS EMPLOYED, THE ELEVATOR MUST BE PLUMB! IF IT IS NOT, IT ALMOST CERTAINLY CANNOT BE MADE TO OPERATE SATISFACTORILY!

There are two basic methods of elevator erection. In this manual only the Vertical Assembly or section-by-section method is considered. InterSystems does not recommend Horizontal Assembly wherein entire elevators or multiple sections thereof are assembled horizontally at ground level and then raised to the vertical and hoisted into position. The potential for damage to the elevator structure is too great.

2.3.1 Vertical Assembly

This method could also be termed section-by-section assembly. **See Figure 2-3.** Because of the weight of the elevator's head section, InterSystems recommends that it always be hoisted in a separate lift and then fastened to the rest of the elevator.

- A. Lift the boot onto the foundation. (See Paragraph 2.2.1 on boot placement) **BE SURE THE BOOT IS POSITIONED CORRECTLY ON THE FOUNDATION AS SHOWN ON THE DRAWINGS.**
- B. While the hoisting gear is still attached to the boot to prevent its tipping, accurately plumb and level the boot base. Use appropriate fasteners to clamp the base securely in position and grout the boot base. Allow the grout to cure before further assembly is attempted.
- C. InterSystems recommends that all joints between elevator sections be weather-proofed by applying mastic compound, especially if the elevator is to remain an outdoor structure. Mastic or caulking compound is to be provided by the user or installer. Do not use weather stripping. Use Grade 5 or higher bolts to connect sections.

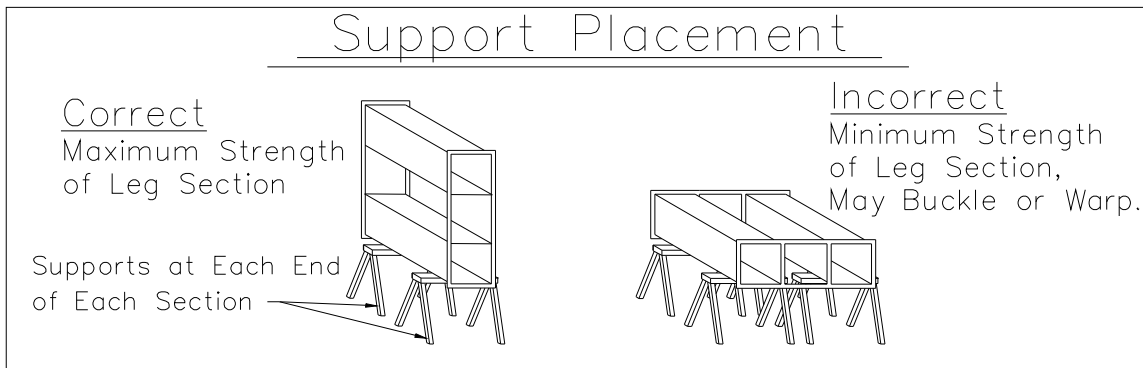
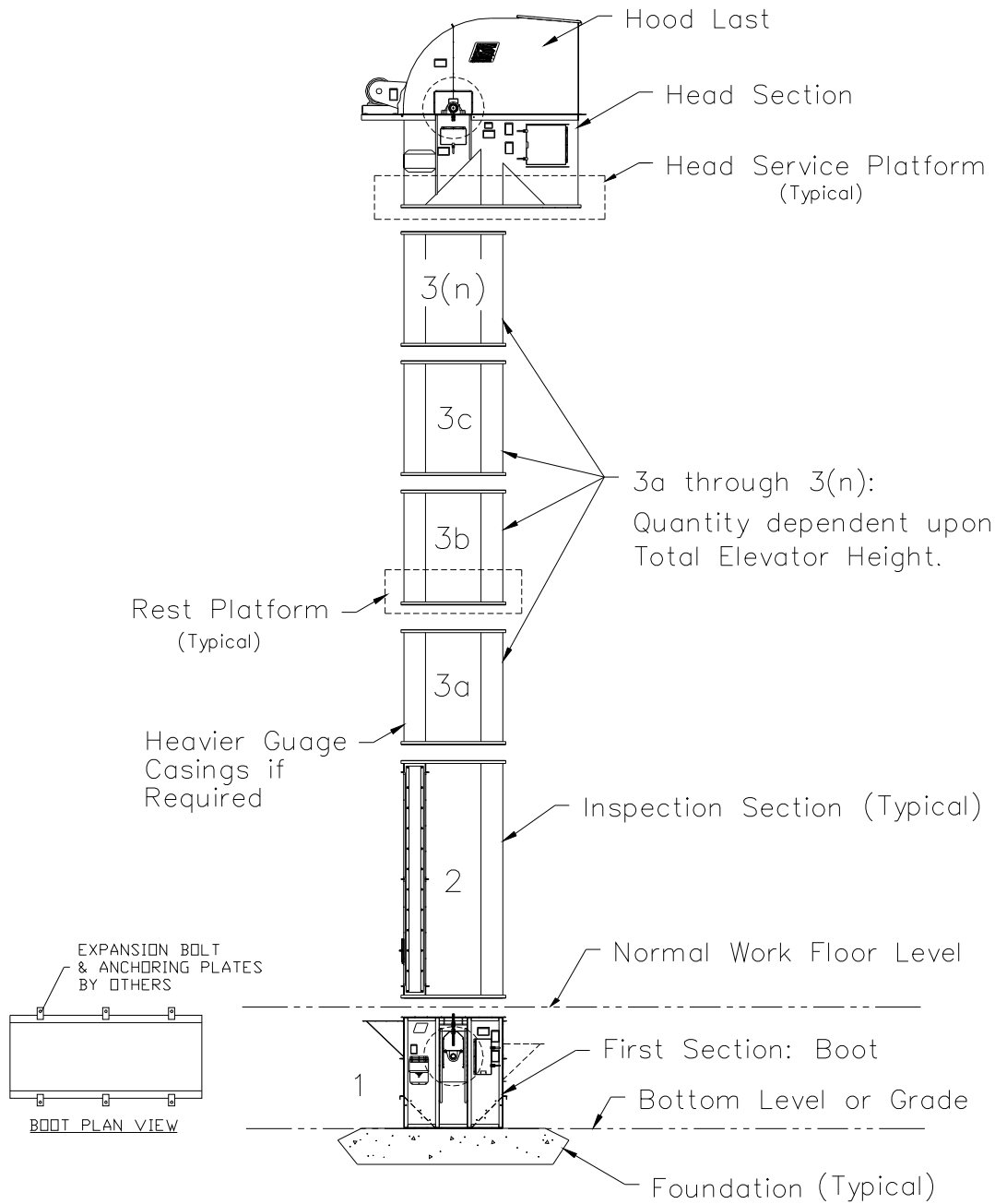

Figure 2-3, Vertical Elevator Assembly Sequence



INCORRECT PLACEMENT OF TRUNK SECTIONS OF VARYING GAGE SHEET METAL COULD RESULT IN SUPPORT FAILURE, COLLAPSE OF THE ELEVATOR AND DEATH OR SEVERE INJURY TO ANYONE IN THE AREA. TRUNK SECTIONS OF VARYING GAGE MUST BE INSTALLED IN THE LOCATIONS SHOWN ON THE CERTIFIED DRAWINGS WITH THE HEAVIER GAGES TOWARD THE BOTTOM.

- D. Begin lifting succeeding elevator sections into position. In most but not all installations, the inspection elevator section is the next section after the boot to be installed.
1. Certain applications, particularly tall elevators, impose heavy structural loads on the elevator leg and boot sections. In these applications, lower trunk sections and the boot section are fabricated from heavier gage materials. Packing list indicates quantity of each gage of trunk. Individual pieces are labeled to show gage.
 2. Continually refer to the certified drawings so that trunk sections are correctly positioned for ladder attachment.
 3. If the customer has ordered the elevator with optional explosion vents in certain elevator sections, these sections must be located in their specified locations.
 4. If the elevator includes a short (non-standard) height elevator section, the certified drawings furnished with the elevator will indicate its intended position, usually immediately above the inspection section.
- E. Plumb each elevator section as it is positioned on the preceding section. Attach guying and/or bracing as determined by pre-installation planning. Shim as required to plumb each section and tighten assembly fasteners. **See Figure 2-4.** The elevator shipment included one or more containers of bulk fasteners, sufficient to completely assemble the elevator and any accessories ordered with it. **FASTENERS WERE NOT PROVIDED FOR ASSEMBLY OR ATTACHMENT OF BRACES OR ANY OTHER EQUIPMENT.**

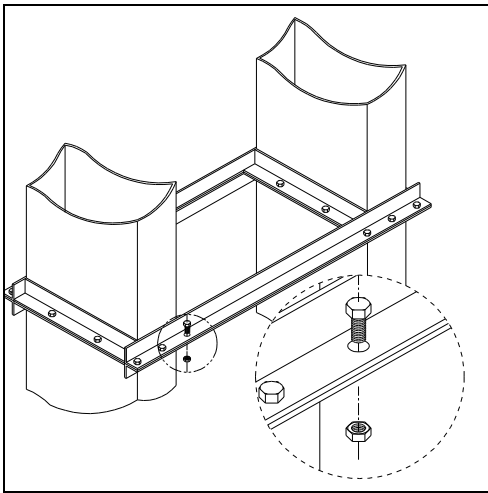

Figure 2-4, Elevator Joint Fasteners

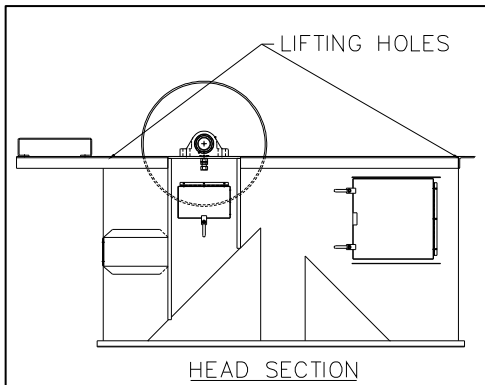

Figure 2-5, Lifting Hole Locations

- F. The last elevator section to be lifted into position onto the elevator is **ALWAYS** the head section. (The hood is not assembled until belt and cup installation is complete). Lift the head onto the top elevator section. See **Figure 2-5**. **DO NOT** install the hood at this time. Plumb the head section and fasten it to the elevator trunk.
- G. The basic elevator structure should now be complete, securely braced and/or guyed.
- H. Assemble the service platform on the elevator head. If supplied by InterSystems, a drawing will be furnished, giving specific assembly instructions and a list of specific fasteners for each detail. Do not weld any platform clamping brackets until all platforms and ladders are assembled and correct installation has been verified.
- I. Assemble the other service and rest platforms if any were ordered and supplied.
- J. Follow these guidelines while assembling ladders:
1. A length of ladder will lead up to a platform and extend upward through the platform opening to the level of the platform's top rail.
 2. An elevator may include a short section of trunk. In these cases, an extra ten foot section of ladder and safety cage is furnished. This ladder and cage section is to be field-modified to match the short section of trunk exactly and compensate for any variances.
 3. The total lengths of safety cage will not equal the total lengths of ladders when rest platforms are used. The bottom edges of the hoops are spaced approximately 7 ft above the floor level of the platforms.
 4. The bottom of the ladder, whether at ground or grade level or at the working floor, should be surrounded by a lockable safety cage or otherwise arranged to prohibit access to unauthorized personnel.
- K. **IMPORTANT:** When the installer is confident that **ALL** ladders and platforms are correctly assembled and located, weld all platform support channels to the elevator casing (trunk). The clamp bands used to temporarily position the support channels during installation were **NOT** meant to permanently attach the channels to the trunk.

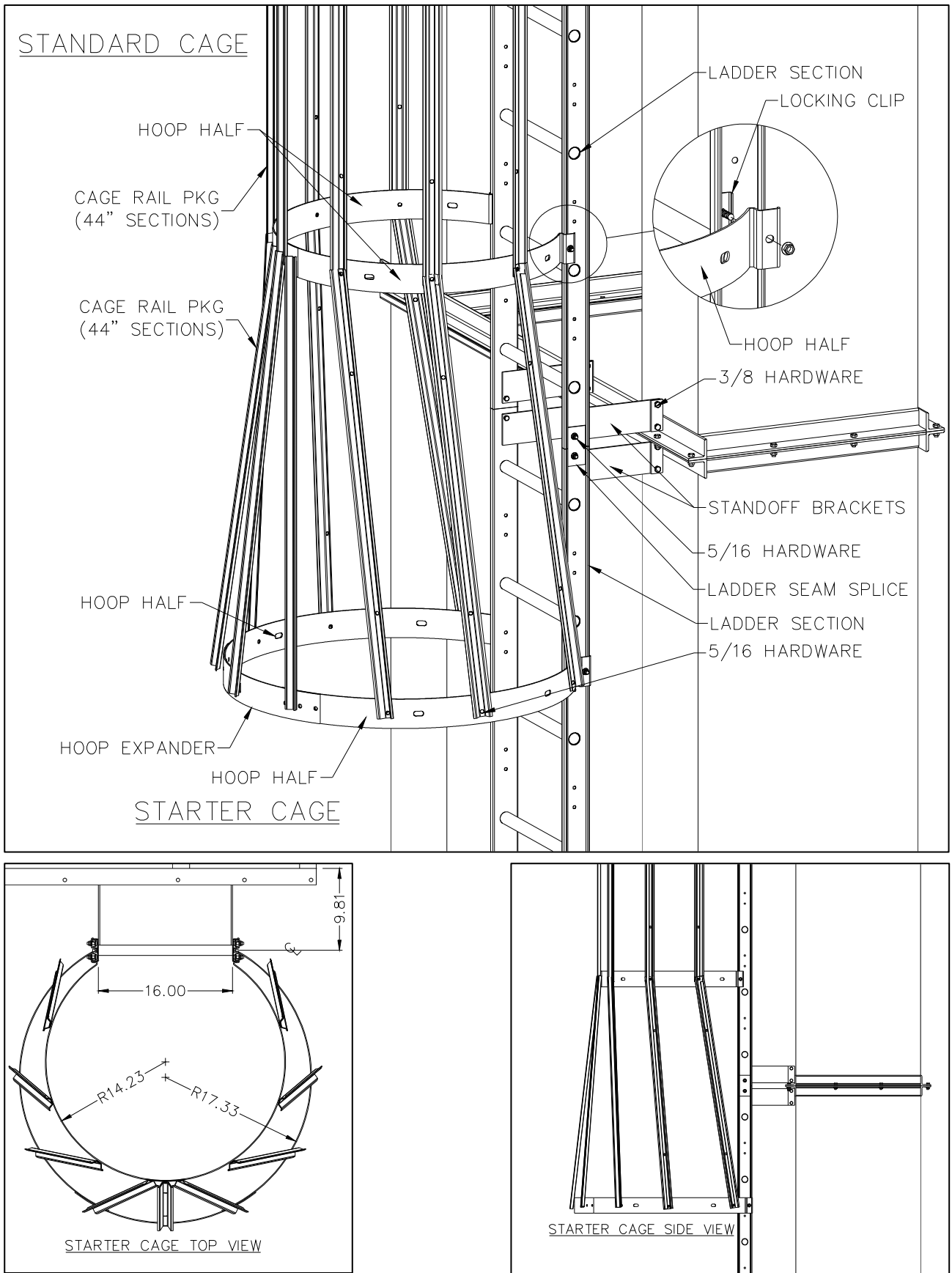

Figure 2.6, Typical Ladder and Cage Assembly

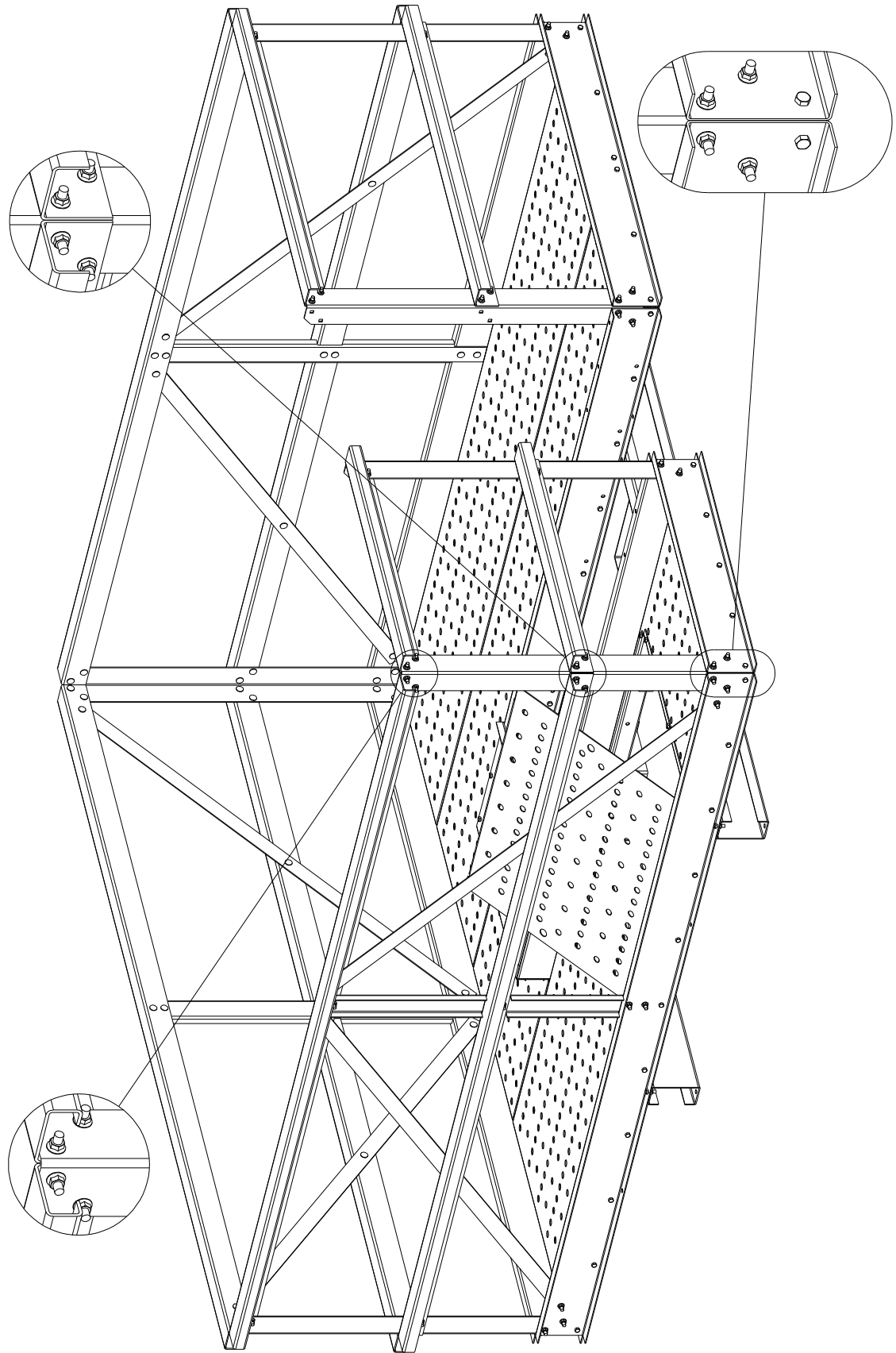

Figure 2.7a, Typical Small Head Service Platform Assembly

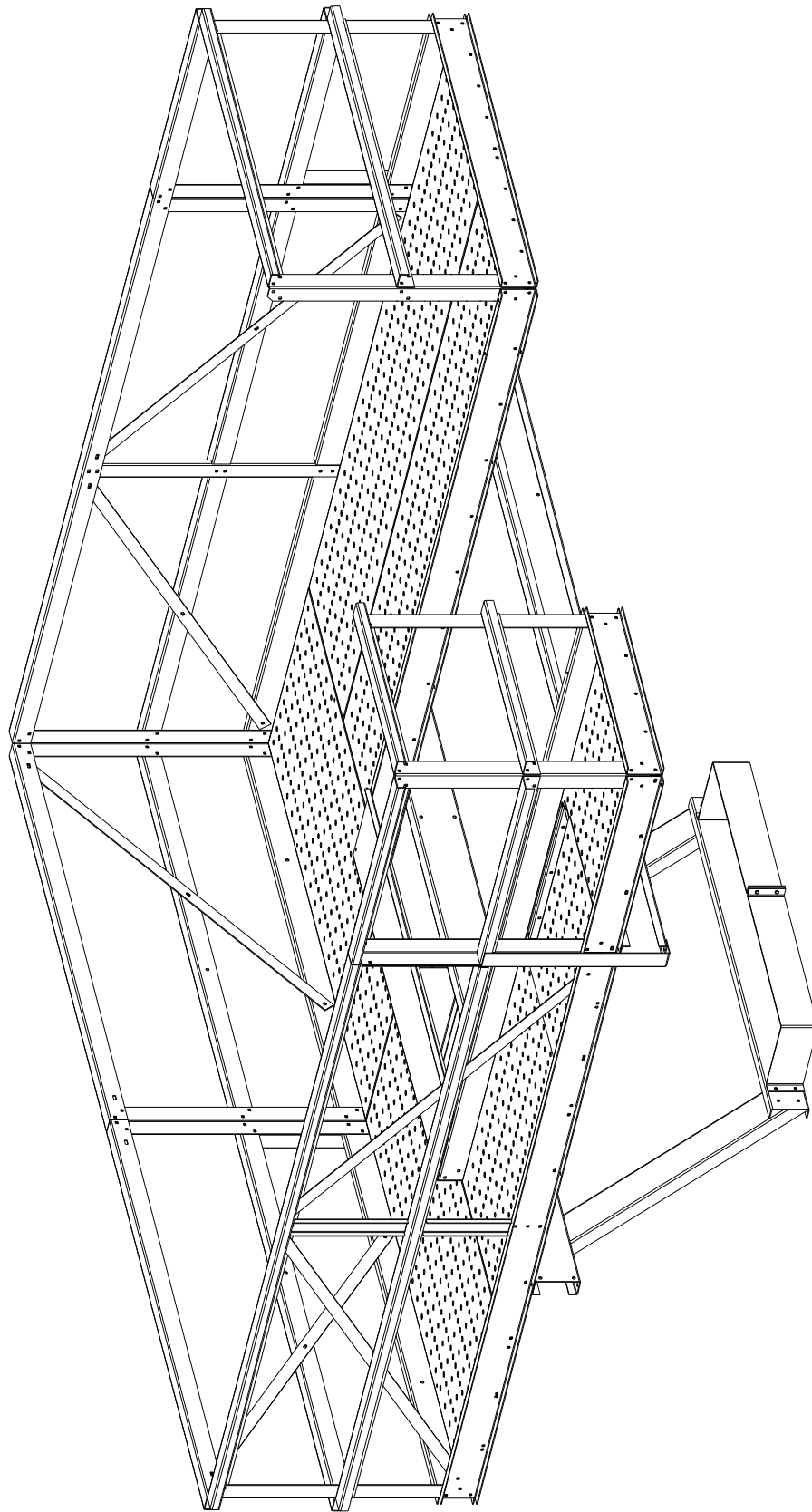

Figure 2.7b, Typical Large Head Service Platform Assembly

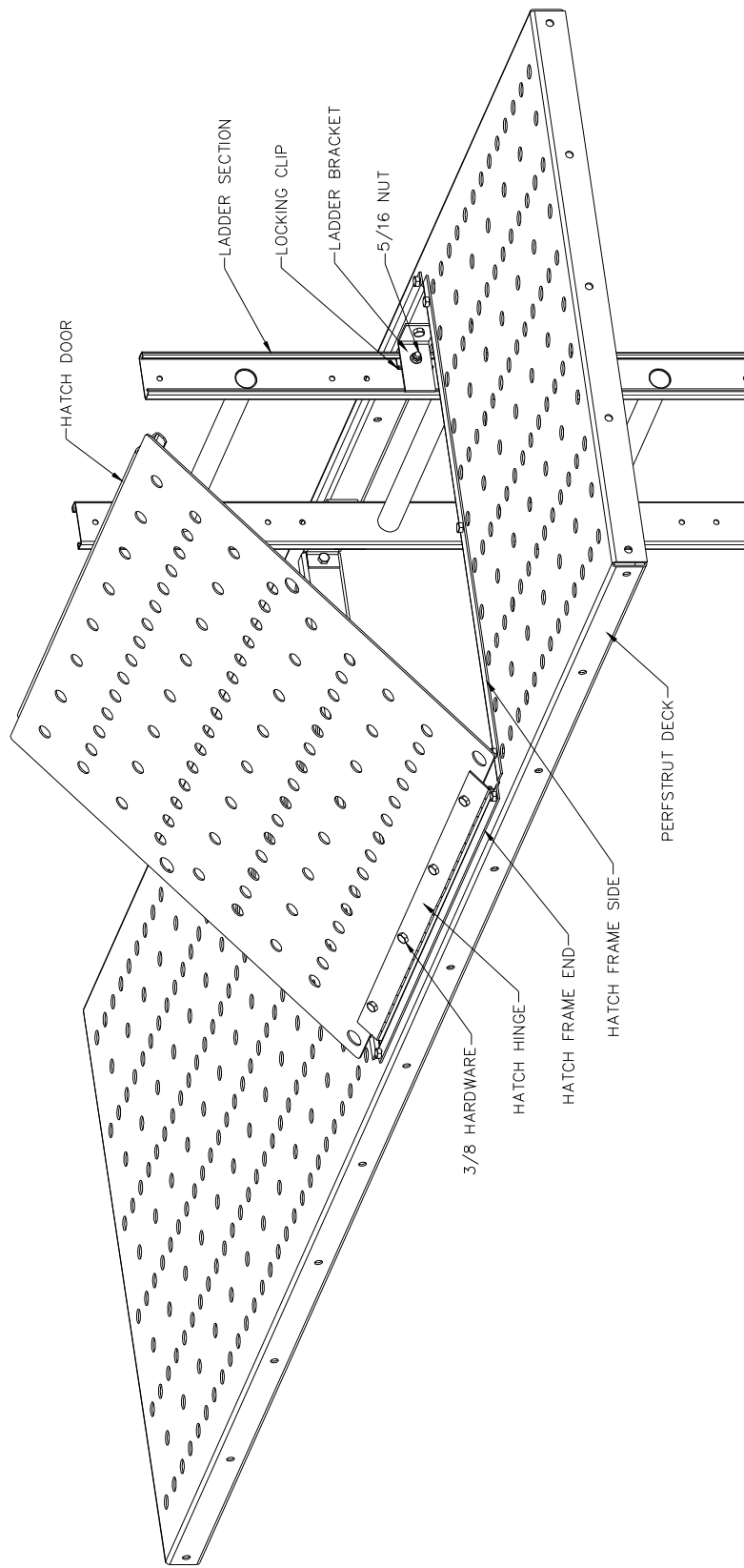
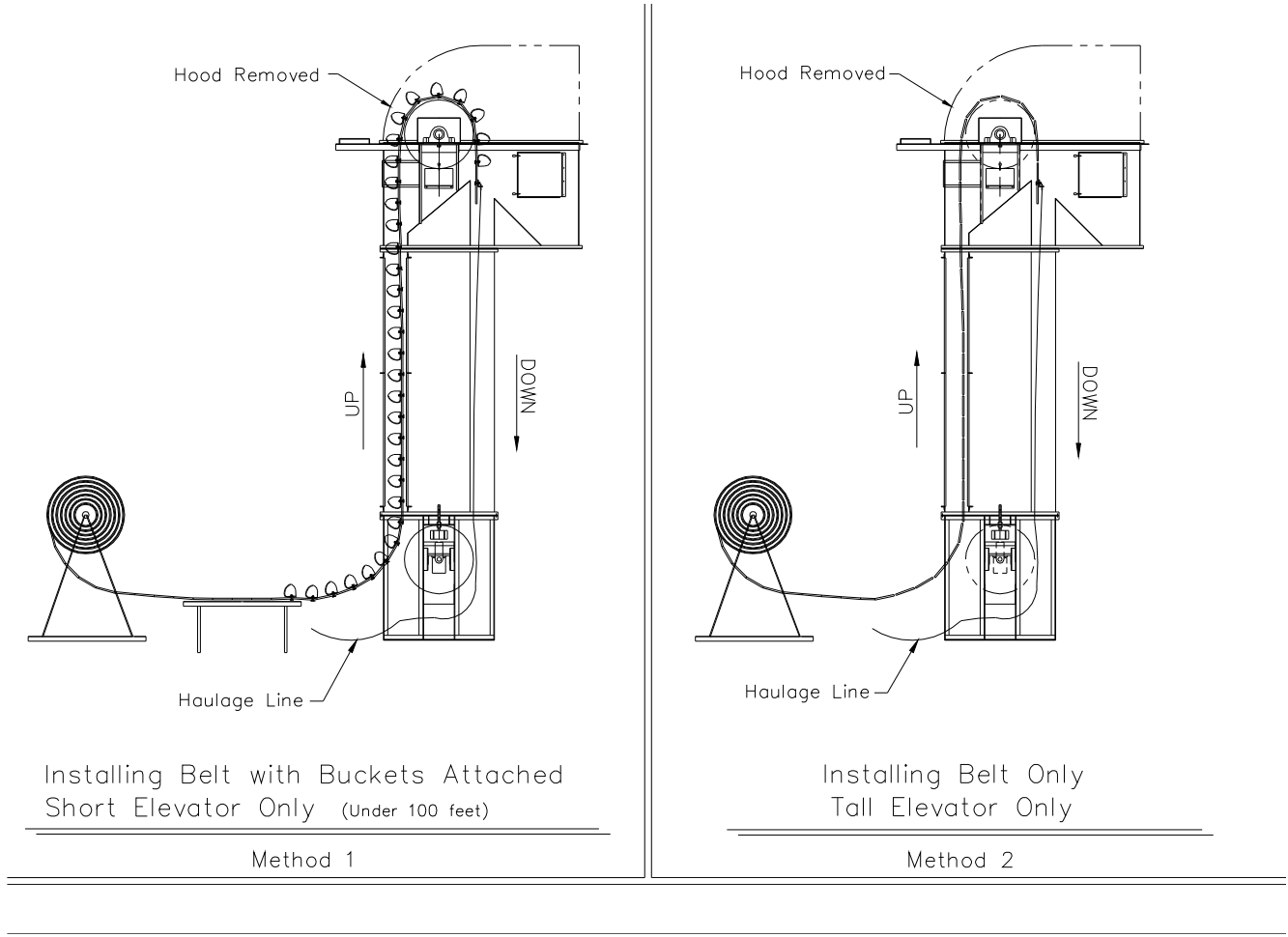

Figure 2.8, Typical Head Service Hatch Assembly

2.3.2 Belt and Bucket Installation

There are two basic methods of installing the belt and buckets in an elevator. Any of three styles of belt splice can be selected. Customers usually have a definite preference as to the style of splice used. Various methods of belt/bucket installation and belt splicing are covered in the following paragraphs. **See Figures 2-9 and 2-10.**



Hole Pattern in Spreader Bar should match
Prepunched Hole Pattern in Belt.

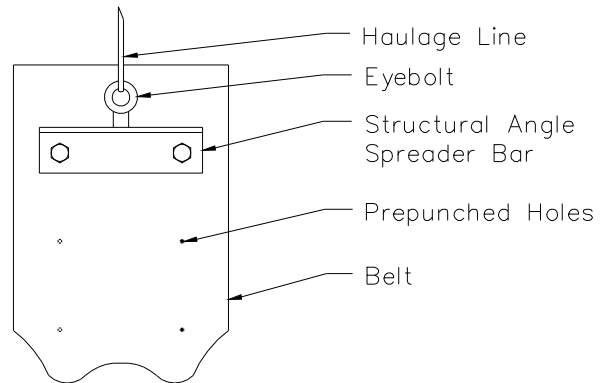
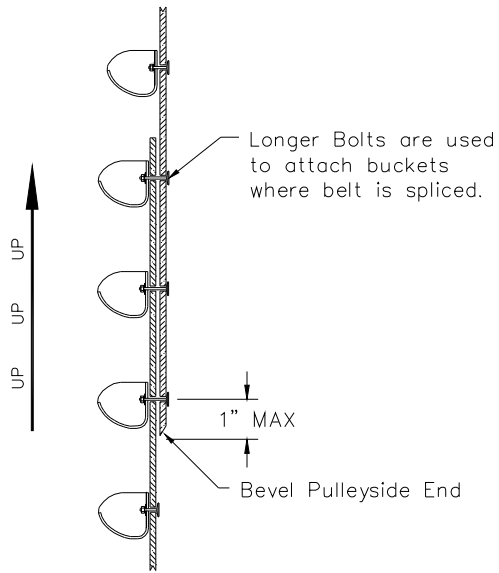
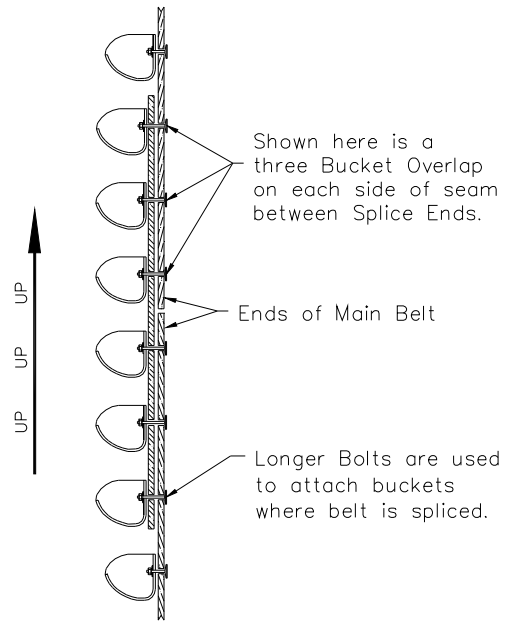

Figure 2-9, Belt & Bucket Installation



View A: Lap Splice



View B: Butt Splice

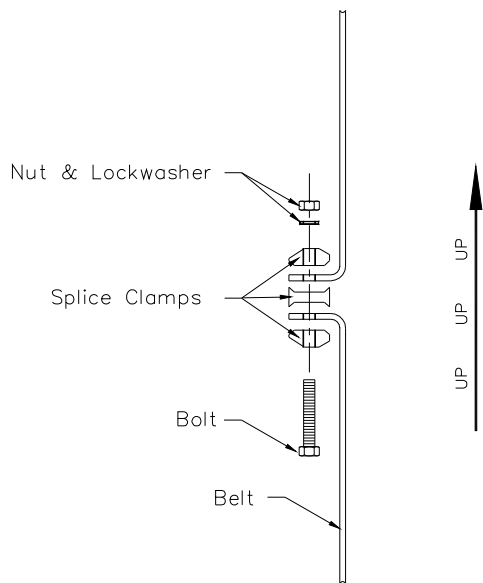

View C: Mechanical Splice

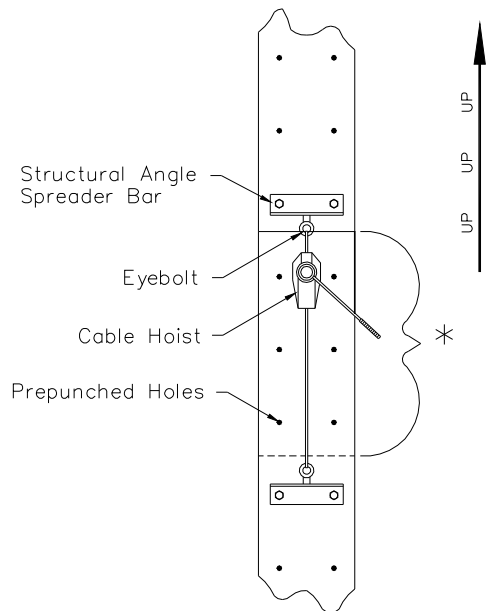

Three bucket splice example:

- For a Lap Splice, overlap 3 bucket spaces.
- For a Butt Splice, overlap 6 bucket spaces.

View D: Spreader Bar Detail

Figure 2-10, Belt Splicing Methods

2.3.3.1 Belt/Bucket Installation

The choice of methods used to install the belt and buckets is determined by: 1) length and weight of belt, 2) number, size, and weight of buckets, 3) open area available around the base of the elevator, and 4) available equipment.

REMINDER: THE HOOD IS NOT YET ASSEMBLED TO THE HEAD SECTION.

The drawings furnished with the elevator identify the belt to be used, either as furnished by InterSystems or as specified by the customer, if provided by others. The drawings also specify the type, size, number, spacing, and pattern of buckets on the belt.

- A. If the elevator boot includes a manual screw takeup as shown in **Figure 2-11**, adjust the takeup screws to raise the pulley to its highest level

OR

- B. If the elevator includes a Posi-Guide gravity takeup as shown in **Figure 2-12**, position a jack under the indicated surface of the takeup side post to lift the takeup, including the pulley.

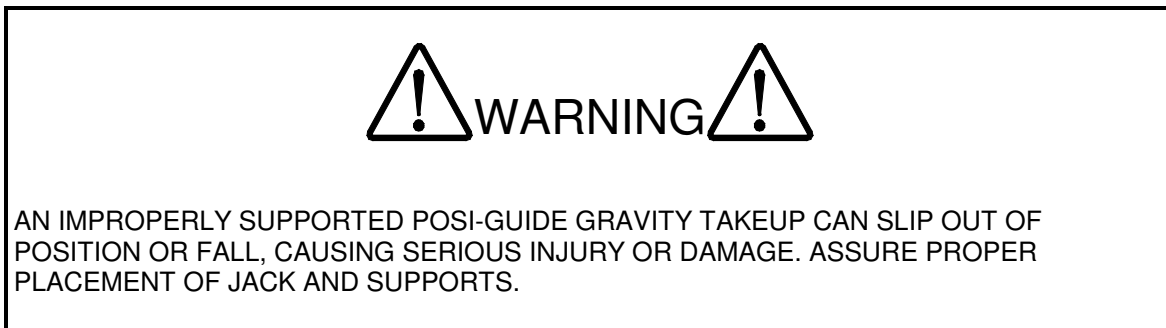

- C. Rig a heavy haulage line (rope or cable) through the removable panel in the UP leg through which the belt with buckets attached will be pulled into the elevator. The line is then hauled up the **UP** leg, over the head pulley, and down the **DOWN** elevator leg. Usually, the line can be passed around the boot takeup pulley and out of a cleanout panel to a winch so the belt can be pulled into the elevator. A spreader bar should be fabricated to connect the haulage line to the belt. **See Figure 2-10, View D.** The bar is preferred to simply punching a hole in the belt and tying or clamping the line to the belt.
- D. "Acme" Nuts should both be tightened against Support Plate to prevent vibration from moving the Takeup out of alignment. Should the Takeup Screw ever require replacement make certain to loosen both "Acme" Nuts to relieve any upward or downward tension before removing the retainer bolts.
- E. The Connection Bolts must be loosened while aligning pulley with adjusting screws and retightened when alignment is complete. Do not add weight to the weight box unless otherwise instructed by the factory. The weight of the takeup, boot bearings, etc., provides proper belt tension in most applications. Additional weight may cause damage to the belt.

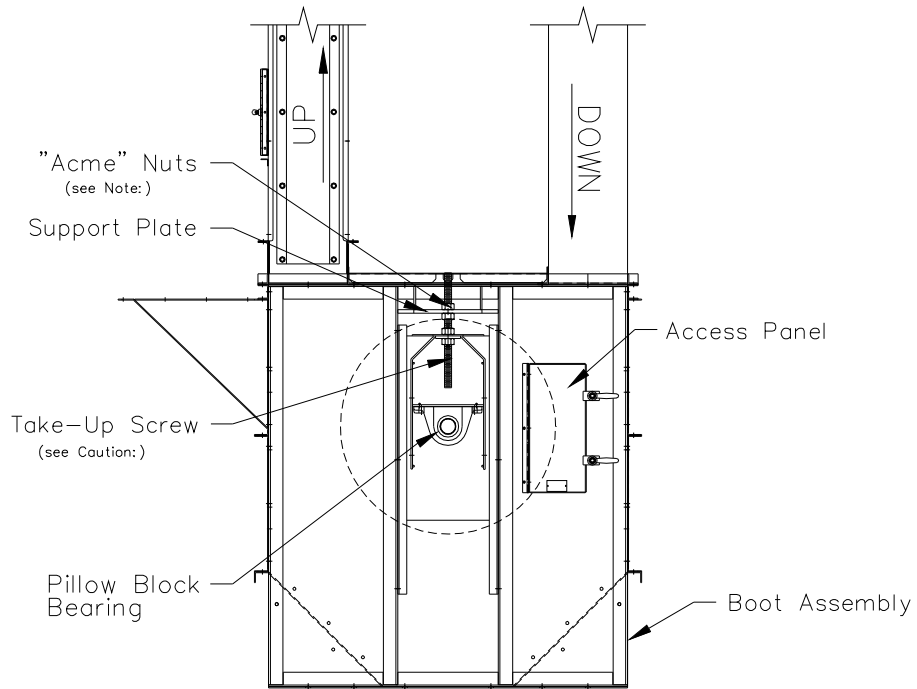

Figure 2-11, Screw Takeup Section

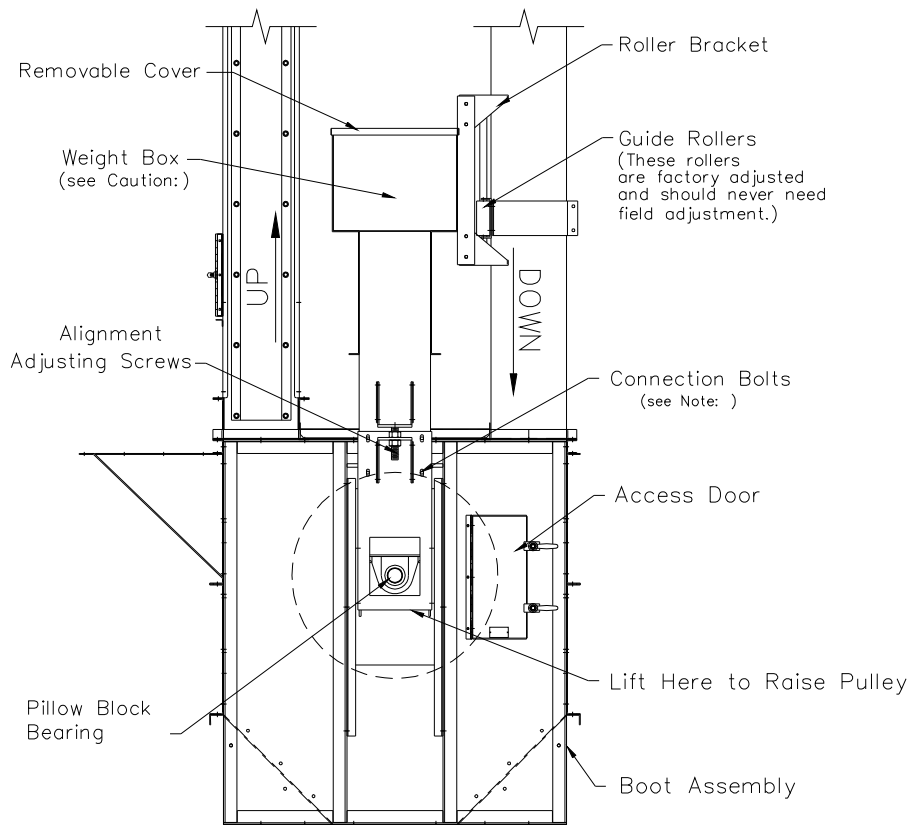

Figure 2-12, Posi-Guide Gravity Takeup

2.3.3.1.1 Method 1; Simultaneous Belt and Bucket Installation; (Less than 100 Ft)

See Figure 2-9, View A.

NOTICE

OMIT AT LEAST THREE ROWS OR SETS OF BUCKETS AT EACH END OF THE BELT UNTIL AFTER THE BELT HAS BEEN SPLICED.

- A. Place a flat table in-line with an opening in the Up leg trunk of the elevator, usually the end panel in the boot section. Remove the boot end panel.
- B. Arrange the roll of belt so it can easily be unrolled onto the worktable and then into the elevator's UP leg. Follow the belt manufacturer's recommendations, if any, as to which side of the belt should contact the pulleys and which side should face outward and contact the buckets.
- C. The belt should already have the bucket mounting holes prepunched in the appropriate pattern. Begin bolting buckets to the belt in the pattern and at the spacing shown on the drawing. The heads of the elevator bolts bear against the inside surface of the belt. Buckets are to bear against the opposite or outer surface of the belt. Elevator bolts should be tightened so as to draw the heads flush with the belt surface. This prevents the bolt heads from scarring the pulleys or working loose. Refer to hardware manufacturer for recommended installation and torque criteria.

Figure 2-13 illustrates general details of bucket attachment.

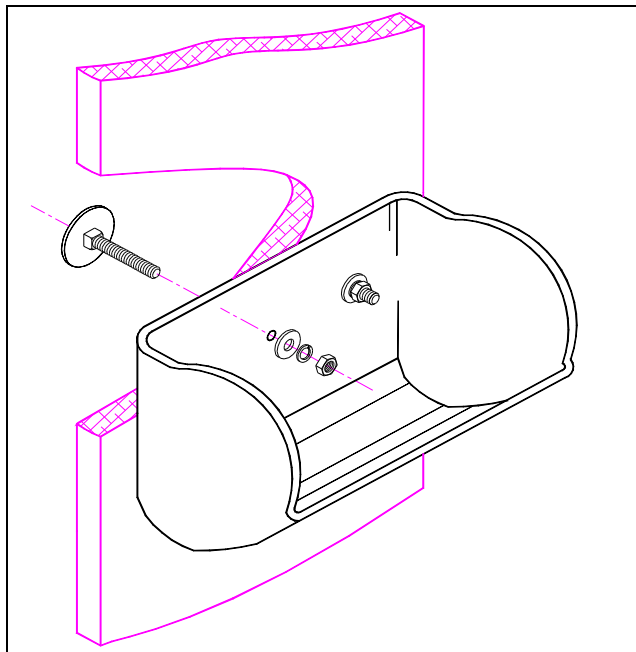

Figure 2-13, General Details of Bucket Attachment

- D. Connect the haulage line to the end of the belt, preferably by means of a spreader bar.
- E. As buckets are fastened to each length of belt, pull the length of belt into the elevator leg. Be sure to keep a strain on the haulage line between hauls so the belt does not drop back down the elevator. As more belt is hauled into the elevator and more strain is imposed on the haulage line, make certain that the line cannot slip and is of proper strength.

NOTICE

BEFORE HAULING THE FIRST LENGTH OF BELT WITH BUCKETS ATTACHED, CHECK AGAIN TO MAKE CERTAIN THAT THE BUCKETS ARE BEING ATTACHED WITH THE BUCKET OPENINGS FACING UPWARD IN THE "UP" LEG OF TRUNK.

- F. As the belt begins to pass over the head pulley, keep the belt roughly centered. Proper belt tracking will be done when belt installation is complete.

- G. When all buckets except those at the ends of the belt where the splice is to be made have been fastened to the belt AND the entire belt has been hauled into the elevator, splice the belt per Paragraph 2.3.4.
- H. Fasten any remaining loose buckets to the belt; in the area of the splice, for instance.
- I. Proceed with initial belt tracking. Refer to Paragraph 2.3.7

2.3.3.1.2 Method 2; Belt Only With Buckets Attached after Splicing Belt

See Figure 2-9

- A. Arrange the roll of belt so that it can easily be unrolled and hauled into the elevator's UP leg. Follow the belt manufacturer's recommendations, if any, as to which side of the belt should contact the pulleys and which side should face outward and contact the buckets.
- B. Connect the haulage line to the end of the belt, preferably by means of a spreader bar.
- C. Begin hauling the belt into the elevator. As more belt is hauled into the elevator, more strain will be imposed on the haulage line. Keep a sharp eye on the line for any sign that it might part or slip on the winch.
- D. As the belt passes over the head pulley, keep the belt roughly centered. Proper belt tracking will be done when belt installation is complete.
- E. Splice the belt. Attach the buckets to the belt in the splice area NOW so the fasteners don't have to be loosened later. Refer to Paragraph 2.3.4.
- F. Adjust the boot takeup pulley to apply tension to the belt. Refer to Paragraph 2.3.7, Step A.
- G. It will be necessary to use the elevator drive or some other means to rotate the belt to allow the buckets to be fastened to it.

NOTICE

IF THE ELEVATOR DRIVE IS OPERATED TO ROTATE THE BELT, MAKE SURE TO LUBRICATE THE REDUCER AND ALL OTHER COMPONENTS WHICH REQUIRE INITIAL LUBRICATION BEFORE APPLYING POWER. DAMAGE WILL RESULT TO ANY COMPONENT OPERATED WITHOUT PROPER LUBRICATION!

- H. Fasten a bucket (or a set of buckets, if there are several buckets in each horizontal row in the pattern shown on the drawings) to an accessible set of mounting holes.
- I. Skip five or ten hole patterns. Fasten another bucket, or set of buckets, to the belt. Continue this sequence until the belt has made one complete revolution through the elevator. Then start fastening buckets or sets of buckets in the center of the gap between the previously installed buckets.

- J. This procedure uses buckets as counterweights. If buckets are fastened to the belt in consecutive continuous rows, the strand of belt in the **UP** leg will carry appreciably more weight than the strand in the **DOWN** leg. Considerable backward pull on the head pulley would result and it would be much more difficult to advance the belt. Continue the sequence until the full complement of buckets has been fastened to the belt.
- K. When bucket installation is complete, complete initial belt tracking. Refer to Paragraph 2.3.7

2.3.4 Belt Splicing

There are three types of belt splices normally used with elevator belts and each is described in the following paragraphs. The splicing method should have been selected during installation preplanning as explained in Paragraph 2.2.6.

NOTICE

REGARDLESS OF THE BELT SPLICING METHOD SELECTED, IT IS VITALLY IMPORTANT THAT THE SPLICE BE PERFECTLY ALIGNED. THE BELT EDGES AT THE SPLICE MUST BE ABSOLUTELY PARALLEL TO PERMIT TRACKING OF THE BELT AND SATISFACTORY ELEVATOR OPERATION.

1. Lap Splice, **Figure 2-10, View A**. This is the easiest splicing method. Make sure the belt ends overlap as shown so the inner belt end does not snag on the pulleys, especially the head pulley which is often lagged or winged.
2. Butt Splice, **Figure 2-10, View B**. This method of belt splicing makes for a smoother running belt as there is no ridge at the splice as with the lap splice. Somewhat more belt is required and resplicing takes somewhat more time than a lap splice since twice the number of buckets must be removed and reinstalled. On the plus side however, the resultant splice is stronger.
3. Mechanical Splice, **Figure 2-10, View C**. This is a superior splice. It makes for the smoothest running belt. However, it is also the most difficult splice to make properly. Vulcanized and cemented splices do not often find application in elevators. The splices are difficult to apply in the field. Also, the belt may have to be respliced after a short period of operation to compensate for initial stretch. Regardless of the method used to splice the belt, a set of spreader bars and a Cable Hoist as shown in **Figure 2-11, View D** will facilitate splicing.

2.3.5 Hood Installation

After belt splicing is complete, hoist the hood into position on the elevator head and reinstall the fasteners.

2.3.6 Drive Installation

Refer to the order information and the certified drawings furnished with the elevator for drive installation. The amount of detail will depend upon whether or not InterSystems furnished all or part of the elevator drive. Abide by the manufacturer's instructions packaged with the reducer, motor, couplings, bushings, etc. Fit and alignment must be held to the limits specified to achieve the expected service life. In any event, the engineer or contractor overseeing elevator installation is responsible for proper installation and operation of the elevator drive.

NOTICE

REVERSE ROTATION OF DRIVE CAN CAUSE DAMAGE TO INTERNAL ELEVATOR AND/OR DRIVE COMPONENTS. BE CERTAIN TO VERIFY CORRECT MOTOR ROTATION ON START-UP. IF MOTOR ROTATES IN THE WRONG DIRECTION, CHANGE MOTOR WIRING TO ACHIEVE PROPER ROTATION.

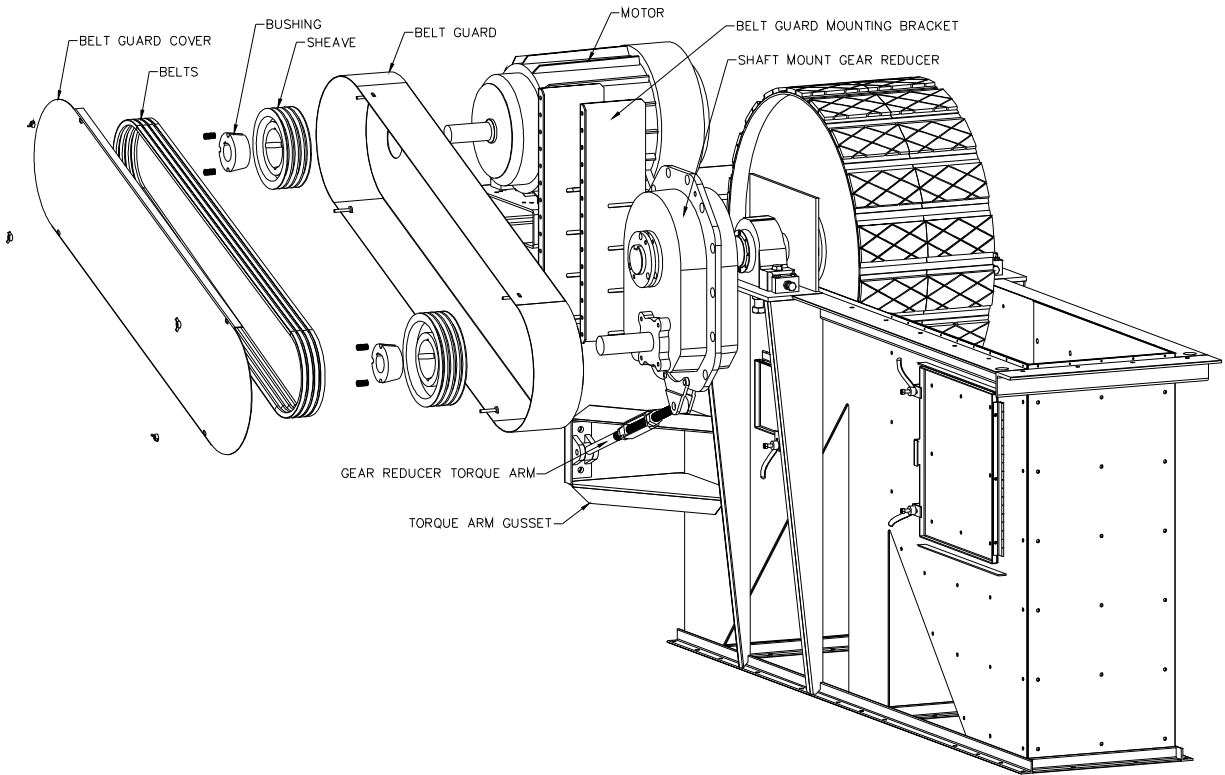

Figure 2-14, Typical Shaft Mount Drive Assembly

2.3.7 Initial Belt Tracking (See Figure 2.15)

NOTICE

THIS PROCEDURE IS TO BE PERFORMED WITH THE ELEVATOR EMPTY! SHOULD ANY PROBLEM BE DISCOVERED, IT WILL BE MUCH MORE DIFFICULT TO CORRECT IF THE ELEVATOR IS FULL OF MATERIAL.

- A. When the belt has been spliced, shift the belt laterally on the head pulley so it is centered on the pulley.
 1. If the elevator has a screw takeup, **Figure 2-11**, adjust the screws evenly downward at both ends of the takeup pulley shaft. Continue adjusting the screws until the belt can be seen to wrap snugly around the takeup pulley.

2. If the elevator has a Posi-Guide Takeup, **Figure 2-12**, then simply remove the temporary support so the weight of the takeup is exerted on the takeup pulley. If the loaded elevator, when tested, is found to need more belt tension, that can be accomplished by adding ballast to the weight box.
- B. Establish a firm, level, horizontal reference plane common to both ends of the takeup or boot pulley shaft. Measure from the reference plane to the pillow block mounting surface at each end of the pulley shaft. If the distances are not equal, adjust the takeup screws, **Figure 2-11**, or the alignment adjusting screws, **Figure 2-12** until the pulley shaft is level.
 - C. Establish a firm, level, horizontal reference plane common to both ends of the head pulley shaft. Measure from the reference plane to the pillow block mounting surface at each end of the pulley shaft. See **Figure 2-16, Detail A**.
 1. If both mounting surfaces and hence both pillow blocks are not at the same height, loosen the mounting bolts for the pillow block on the low end of the head shaft.
 2. Turn the jack screws evenly to raise the pillow block until both ends of the head shaft are level. Shim between the pillow block and its mounting surface. Shims should be as nearly equal to the area of the pillow block base as possible so as not to concentrate stress on a small area of the bearing housing, causing it to fracture. Slotted shims are suitable and easy to use.
 3. After the pillow block has been shimmed to level the head pulley, back off the jack screws so the full weight of the pillow blocks rests on the shims. Tighten the mounting screws.
 - D. If it has not already been done, lubricate all components requiring initial lubrication. This includes, but is not limited to, the drive reducer. Reducers are usually shipped dry, without lubricant. Refer to the manufacturer data, which should have been saved when the components were unpacked or consult the manufacturer or a local supplier of the component.
 - F. Start the elevator. Observe the belt as it passes around the pulleys. If the belt appears to be "walking" towards the edge of the pulley, be ready to shut down the elevator drive. Several complete revolutions of the belt will be required before the belt reaches a steady-state tracking condition.
 - G. If the belt steadily tracks on or near the center of both pulleys, no further action is necessary. If, however, the problem is that the elevator structure is significantly out of plumb, the remedy is going to be more complex! The elevator will have to be plumbed **NOW** after all the guying and/or bracing has been installed. Study the diagrams in **Figure 2-15**. Try to correct belt tracking first by adjusting the boot takeup pulley and then by shimming the head pulley pillow block bearings. If altering pulley alignment has no effect, run the elevator until the belt splice is accessible through the inspection door. Use a long straight-edge (10' or longer) or taut line to see if the belt was spliced squarely. If necessary, resplice the belt.

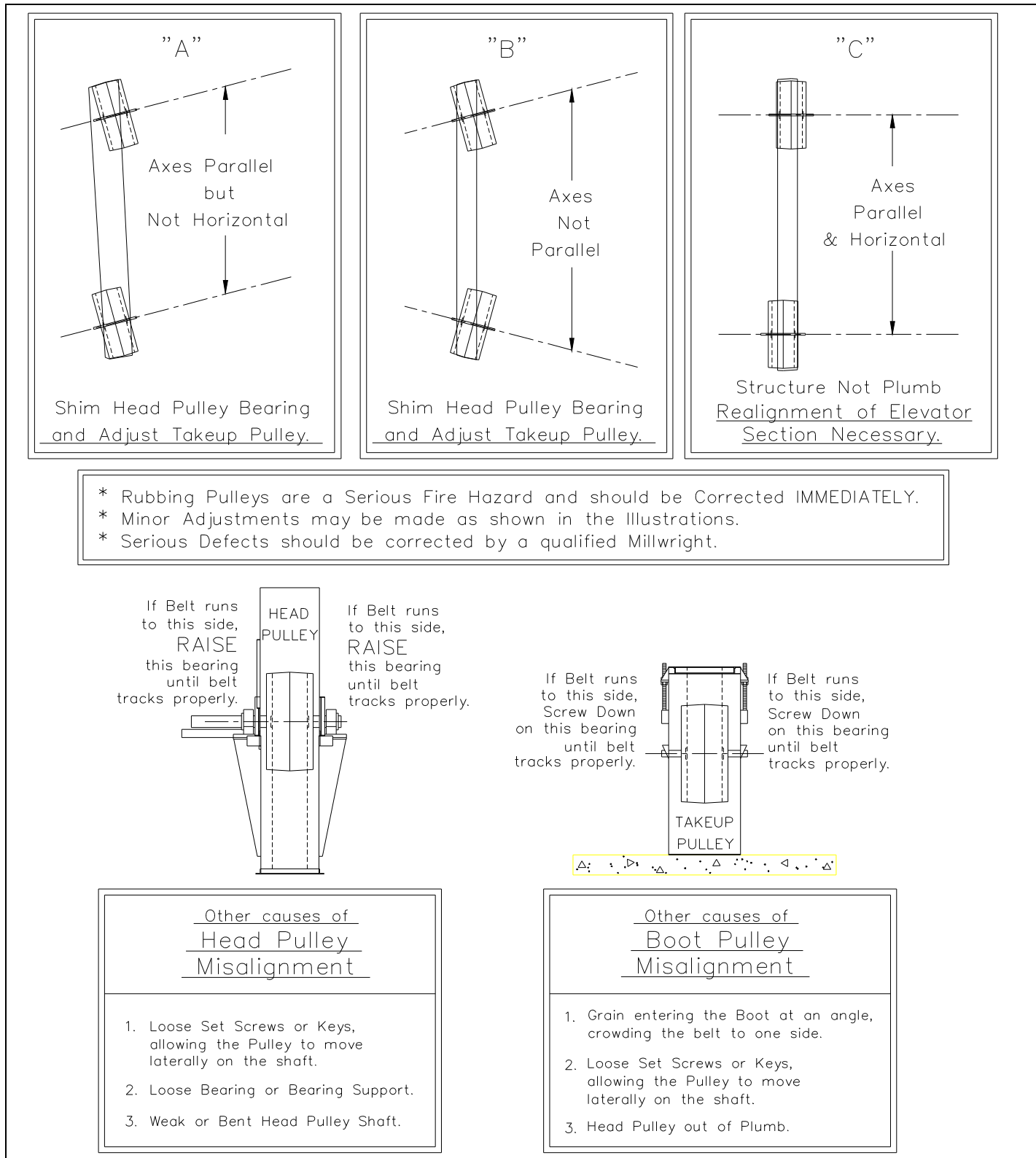
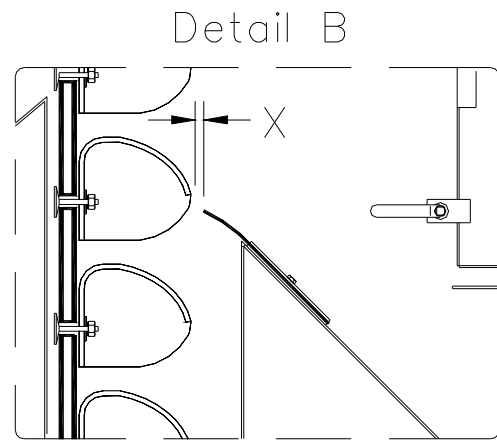
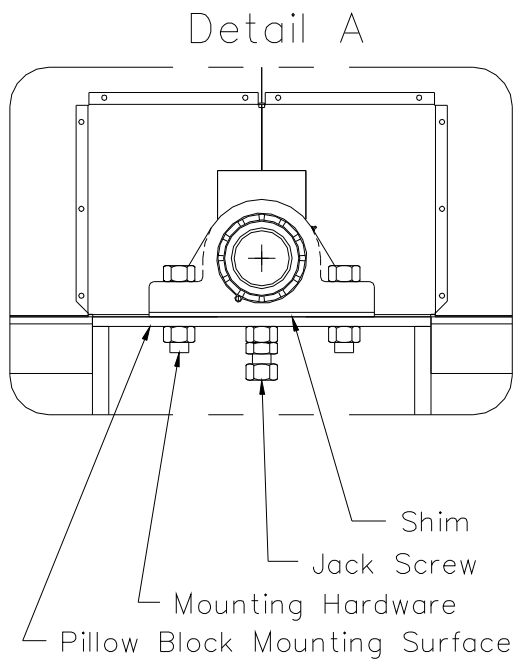
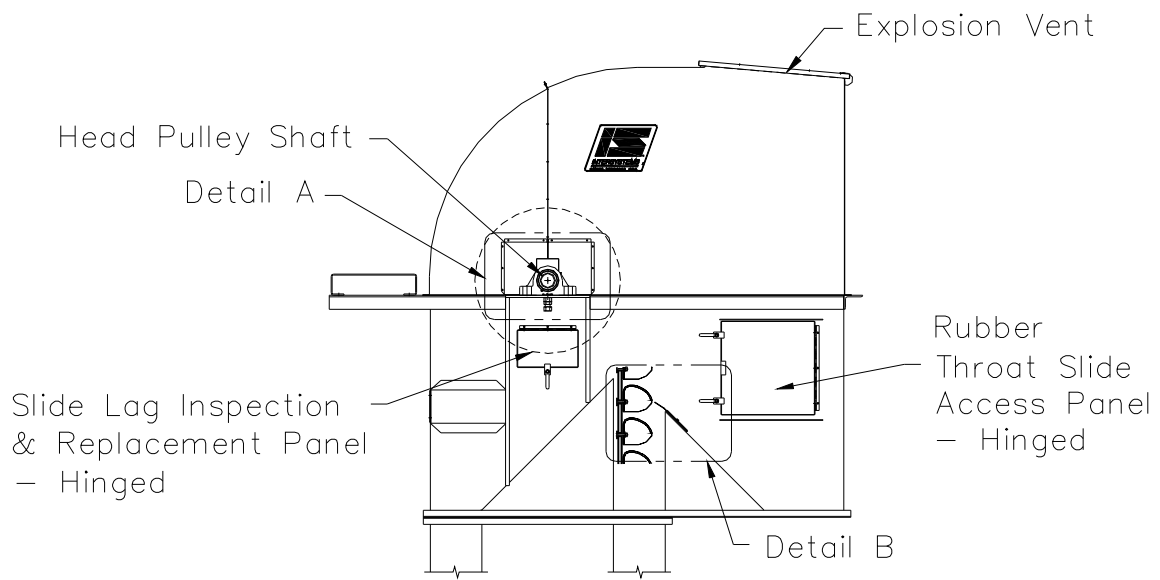

Figure 2-15, Belt Tracking Guidelines



Rubber Throat Slide Adjustment
 $X = 1/4$ to $1/2$ Inch

Refer to:
Paragraph 2.3.5., Step C.

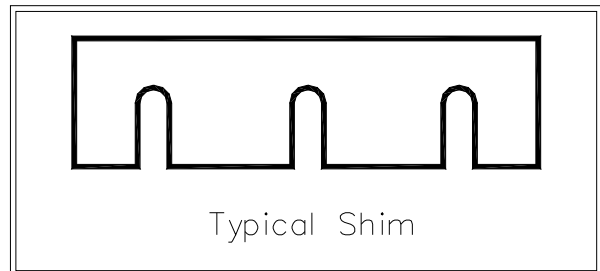

Figure 2-16, Head Section Details

2.3.8 Rubber Throat Slide Adjustment

The rubber throat slide, **Figure 2-16, Detail B**, should be positioned so there is 1/4" to 1/2" clearance between the edge of the slide and the outer lips of the buckets. Proper adjustment will minimize one cause of downlegging.

NOTICE

FOR LAP OR BUTT SPLICED BELT, INCREASE THE CLEARANCE DIMENSION BETWEEN THE RUBBER THROAT SLIDE AND THE BUCKETS BY THE THICKNESS OF THE BELT TO COMPENSATE FOR THE DOUBLE BELT THICKNESS.

2.3.9 In-Service Belt Tension

If the belt tracks properly and does not slip when the elevator is operating at maximum capacity, then the belt is sufficiently tensioned. Tension adjustment, however, must wait until the entire installation is complete and material (the product; grain, etc.) can be conveyed to and from the elevator.

- A. While observing all prudent safety precautions, posted or otherwise, examine the belt as it passes over the head pulley **WHILE** the elevator is under load. The pulley should track properly. Belt slip is most often detected by observing the bearing setscrews on the head and tail shafts while counting the number of revolutions of pulley in the same period of time, typically 30 to 60 seconds.

REMINDER: SINCE THE HEAD PULLEY IS LAGGED AND ITS EFFECTIVE DIAMETER IS LARGER COMPARED TO THE BOOT PULLEY, HEAD PULLEY ROTATION SPEED WILL BE SLIGHTLY SLOWER THAN THE BOOT PULLEY EVEN IF THERE IS NO BELT SLIP.

If the belt is slipping and all other conditions appear to be normal, adjust the takeup.

1. If the elevator has a screw takeup, adjust the acme screws evenly to force the pulley downward and increase belt tension.

OR

2. If the elevator has a Posi-Guide gravity takeup, adding ballast to the weight box will increase belt tension. The ballast should be spread evenly throughout the box for best results. Be sure to reinstall the weight box cover to prevent rainwater from accumulating in the weight box. (See **Figure 2-12**)

- B. Verify that belt speed closely approximates that specified on the drawings. If it does not, check the drive system, especially if all drive components were not furnished by InterSystems. Among the points to consider are:
 1. If the elevator includes a chain drive, compare the number of teeth of the drive and driven sprocket. Verify that the resultant ratio, taken together with the reducer's output speed, will produce the specified final pulley RPM.
If the elevator includes a V-belt drive, compare the pitch diameters of the drive and driven sheaves. Verify that the resultant ratio taken together with the reducer's output speed will produce the specified final pulley RPM.
 2. Whether the elevator employs direct coupled, chain, or belt drive, you must verify that the motor's speed and the reducer's reduction ratio will produce the required output speed to produce the specified final pulley RPM.

3. If no other problem is uncovered, check to see that the drive components are not slipping on the shafts. Sometimes during field assembly, the keys are inadvertently left out.
- C. If the belt speed matches the specified value and the elevator does not seem to be handling the specified capacity, review the factors set forth in Paragraph 2.2.3, Elevator Intake and in Paragraph 2.2.4, Elevator Discharge. The elevator will not operate at maximum capacity if material does not flow freely into and out of the elevator!
 - D. Verify that the belt continues to track the center of the head and boot takeup pulleys. If it does not, check to see if the material being fed into the elevator is entering at an angle from one side or the other and forcing the belt to one side of the pulley. This condition, if it occurs, must be corrected. Continual lateral pressure on the belt can cause the belt edge to rub against the elevator structure. At the very least, the belt will wear rapidly. More serious than wear, a fire and/or explosion can occur if belt friction generates sufficient heat.
 - E. After the elevator has operated for a period of time, the takeup may require readjustment to compensate for initial belt stretch. Depending upon the amount of initial stretch, the belt may even have to be shortened and respliced.

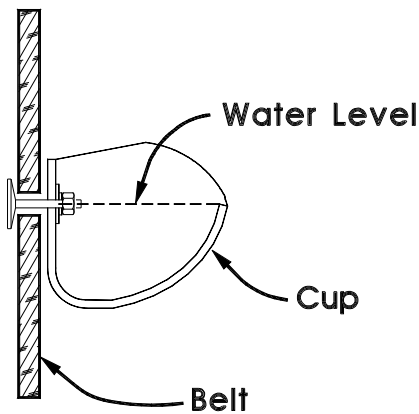

2.3.10 Elevator Bucket Filling

Proper filing of the buckets is vital to achieving the design capacity of the elevator. Buckets should be filled to slightly above the water level line shown in **Figure 2-17**. In Subsection 2.2.3, Elevator Intake, discusses some of the factors influencing elevator capacity in general and bucket filling in particular.

The following procedure can be used to give a reasonably accurate capacity indication for an elevator leg when used **without a bulkweigh system**. For calibration with the use of a bulkweigh system, see the next page.

Figure 2-17, Bucket Water Line Drawing

- **STEP 1**--Make certain that the pit, all spouts, and the legs are all empty. Be certain you know the exact empty and gross weight of the truck, train car or whatever you are using for the test.
- **STEP 2**--Start the elevator and make certain it is running properly and ready to receive material. Load the pit but do not start the feed to the elevator.
- **STEP 3**--Open the feed to the elevator and start the timer.
- **STEP 4**--It is very important to keep the pit full in order to keep a constant feed rate to the elevator. Continue loading the pit until the truck, train, etc. is empty. When the pit empties, stop the timer.

- **STEP 5**--After the entire system empties, use the formula below to calculate BPH capacity

$$\text{Net material weight} = (\text{Gross weight truck}) - (\text{empty weight})$$

$$\text{TF} = 60 / (\text{minutes to run the load})$$

$$(\text{net material weight} / (\text{lbs. per bushel of material})) \times (\text{tf}) = \text{BPH}$$

OR

$$(\text{net material weight}) / (\text{lbs. per cu ft of material}) \times (\text{tf}) = \text{cu FPB}$$

- **STEP 6**--Repeat procedure if necessary to confirm results.

EXAMPLE	
Gross truck weight with corn (56# PER BU)	35,000
Empty truck weight	10,000
Time from opening pit gate to pit empty--5 min	
35,000 - 10,000 = 25,000 net pounds of corn	
60 / 5 min = 12 (tf)	
25,000 lbs / 56 lbs per bu. x 12(tf) = 5357 BPH	

The following procedure can be used to give a reasonably accurate capacity indication for an elevator leg when used **with a bulkweigh system**. For calibration without the use of a bulkweigh system, see the previous page.

- **STEP 1**--Make certain that the pit, all spouts, the leg and the bulkweigh system are all empty.
- **STEP 2**--Start the elevator leg and make certain it is running properly and prepare bulkweigh system to receive material. Load the pit but do not start the feed to the elevator.
- **STEP 3**--Open the feed to the leg and start the timer.
- **STEP 4**--After exactly 3 minutes, shut down the feed to the leg.
- **STEP 5**--After the entire system empties, check the throughput on the bulkweigh system and use the formula below to calculate BPH capacity.

$$1 \text{ lbs. through bulkweigh} / \text{lbs per bushel of material} \times 20 = \text{BPH}$$

OR

$$1 \text{ lbs through bulkweigh} / \text{lbs per cu ft of material} \times 20 = \text{cu FPB}$$

- **STEP 6**--Repeat procedure, if necessary, to confirm results.

EXAMPLE

Handling wheat @ 60 lbs per Bu.
After 3 min run, 35,000 lbs went through bulkweigh system

$$35,000 / 60 \times 20 = 11,667 \text{ BPH}$$

If Unable to Get Capacity

1. Check for obstruction in inlet spouts or boot hoppers
2. Check slope of inlet spouts and hoppers. Should be 45 degrees or greater.
3. Check height of boot inlet hopper, where grain entered boot, both up and down legs.
4. Check belt tension--adjust boot pulley takeups.
5. Check position of pulley. Takeups may be carrying pulley too high for cups to dip into grain.
6. Varnished or painted cups must be given time to polish up for free grain discharge.
7. Check cups for caking or deformation.
8. Check head pulley RPM

III. Maintenance

NOTICE

Thoroughly read Section I, regarding safety information before beginning installation and startup.

3.1 General Maintenance

A good maintenance program involves thorough general housekeeping, periodic inspection, adequate lubrication, and timely adjustment.

3.2 General Housekeeping and Periodic Inspection

At frequent and regular intervals, perform these housekeeping chores and inspections:

- A. Remove accumulated dirt from the motor, reducer housings and bearings.
 1. Motors depend upon unobstructed airflow over their housings for effective cooling.
 2. Reducer gear cases must also be free of dirt for effective heat radiation. Most reducers have a pressure vent to permit escape of vapors, which may build up internally. If dirt blocks a vent, internal pressure can rupture seals. Leaking lubricant will contaminate the product being handled by the elevator and reducer failure and subsequent equipment downtime will definitely result if the leak is not discovered in time and repairs made. Original equipment manufacturers will refuse to honor warranties if a motor or reducer fails because dirt accumulation leads to overheating or lubricant failure.
 3. While cleaning the reducer, check the reducer's lubricant level and condition. If the level is low, find and correct the leak. If the lubricant is dirty or shows signs of overheating, schedule a change of lubricant as soon as possible.
 4. Listen carefully for a noisy motor, reducer, or bearings, or a rubbing belt. Any of these sounds can be a forewarning of overheating and fire or explosion. Correct any problem discovered immediately!

- B. Periodically remove the drop-down clean out door from each end of the boot. Cleanse the boot of all accumulated dirt and material to prevent vermin infestation and corrosion.
 - 1. If the boot has a screw takeup, clean the acme takeup screws and nuts. Apply a protective coating of rust-inhibiting lubricant. Future takeup adjustment will be much easier.

OR

- 2. If the boot has a Posi-Guide gravity takeup, cleanse the polyethylene guide sleeves and the stainless steel guide shafts of accumulated dirt to insure that the pulley and weight box assembly move up and down freely. The guide sleeves and shaft **DO NOT** require any lubrication. In fact, any lubricant applied would merely attract dirt, preventing smooth operation of the takeup.
- C. Examine the head lining. Extreme wear patterns can sometimes distort the discharge and if not corrected, wear completely through the head. Spouting may also wear through.
- D. Check to make sure the pressure relief vents, if installed, on the head and/or legging are unobstructed. In order to provide relief, they must be free to blow out.
- E. Inspect all ladders and platforms. Tighten any loose fasteners. Note any defective field welds and schedule immediate repair. Also schedule replacement for any damaged ladder sections, platform structural members, or floor grates. While inspecting platforms and ladders, be sure to examine guying cable brackets and /or bracing. Note any defects and schedule immediate repair.
- F. Examine guying. Tighten any clamp fasteners, which are loose. If a cable is excessively slack, adjust turnbuckles to restore tension.



- G. Check the belt takeup in the boot section. If the pulley has been adjusted to its lowest (maximum) limit, it will be necessary to shorten the belt by removing one or two rows of buckets and resplice the belt as explained in Paragraph 2.3.4.
- H. It is also advisable to check the condition of all infeed and discharge spouting associated with the elevator for damage and wear.
- I. When all specific inspections have been carried out, stand back and generally observe the elevator and any associated equipment. Look and listen for any problem not covered in the preceding list.

3.3 Lubrication

In all cases, the manufacturers of the individual components have precise recommendations for periodic lubrication of their products. Strict adherence to these procedures will result in a minimum of down time and maximum component life.

3.3.1 Reducer

Refer to the documentation furnished with the reducer. The user must interpret this information in light of the severity of duty in each application. If there is any doubt, contact the manufacturer or a local supplier of the reducer for specific recommendations.

3.3.2 Motor

Many motors have sealed and permanently lubricated bearings; with these, no lubrication is possible or desirable. If bearings of this type become noisy or overheat, they must be replaced.

Motors having bearings that can be re-lubricated are usually larger integral horsepower sizes. Special pressure lubricating equipment may be required. Refer to the documentation furnished with the motor.

3.3.3 Head & Boot Shaft Bearings

Mounted bearings DO require periodic lubrication. The amount and frequency depends in large extent upon the severity of the operating environment and the duty cycle. Refer to manufacturer's recommendations for frequency, type and amount of lubrication.

3.3.4 Roller Chain Drive

If the elevator includes a roller chain drive furnished by InterSystems, the chain case or guard also serves as a lubricant reservoir. The lubricant level should be high enough to immerse the lower sprocket teeth and chain, yet not so high as to leak from the joints in the case.

3.3.5 Sleeve Guides and Shafts

The polyethylene sleeve guides and stainless steel shafts of Posi-Guide gravity boot takeups DO NOT require ANY lubricant. In fact any lubricant applied to these components will only attract dirt and interfere with their operation.

3.4 Adjustment and Repair Procedure

3.4.1 Elevator Belt Tension

3.4.1.1 Boot Takeup (Belt Tension) Adjustment

Paragraph 2.3.9 states the InterSystems position regarding proper belt tension. Paragraph 2.3.9, Step A explains how to adjust a screw takeup boot or how to add weight to a gravity takeup boot.

3.4.1.2 Drive V-Belt (If Installed)

If the drive includes V-belts, there are several methods of measuring tension.

- A. Direct reading using a gauge specifically designed to read belt tension. Consult a local industrial V-belt supplier.
- B. Indirect method using a pull hook scale and a straightedge. The engineering section of many catalogs explains the procedure. In either event, most V-belt catalogs explain proper belt tensioning procedures and give specific tension values.

3.4.2 Belt Tracking

Paragraph 2.3.7 explains the recommended method of tracking the belt.

READ THIS FIRST!

If a tracking problem exists and cannot be corrected by adjusting the boot takeup but instead requires that the head and/or boot pulley shaft pillow blocks be shimmed, there may have been a shift in the elevator structure. Look for the following conditions, in order of probability:

- A. Worn or damaged pulley
- B. Uneven belt stretch. Perhaps the belt is tearing along one edge. Check the splices.
- C. Prolonged uneven infeeding of elevated material along one edge of belt or off center loading on the boot.
- D. Bent head or boot pulley shaft.
- E. Bending or buckling of one or more elevator sections.
- F. Damage to guy cable system or deadman shifting.

3.4.3 Belt Splicing

Refer to Paragraph 2.3.4.

3.4.4 Throat Slide Adjustment

Refer to Paragraph 2.3.6.

3.4.5 Roller Chain Tension

Many roller chain catalogs include instructions for properly tensioning roller chains and give specific values. Excessive tension can cause accelerated chain and sprocket wear, destroy bearings, and bend shafts. In extreme cases, excessive tension can cause structural damage.

IV. Spare Parts

4.1 Scope

The certified drawings furnished with the elevator list the components, which are likely to require replacement. Replacements for any other components, including structural members can be supplied upon request.

4.2 Ordering Parts

Parts orders or requests for technical assistance should be directed to:

InterSystems
9575 No. 109th Ave.
Omaha, NE 68142
Phone: (402) 330-1500
FAX: (402) 330-3350

Please have available the Model Number and Serial Number of the equipment in question, as well as the location where the equipment is INSTALLED.

V. Warranty

InterSystems reserves the right to make changes in design or in construction of equipment and components without obligation to incorporate such changes in equipment and components previously ordered.

WARRANTY, LIMITATION OF LIABILITY, DISCLAIMER OF IMPLIED WARRANTIES: InterSystems manufactured equipment and components are guaranteed against defects in workmanship or materials for one year from date of shipment. The obligation of InterSystems with respect to any goods is limited to replacement or repair of defective parts and equipment, provided those parts are returned, shipping costs prepaid, to InterSystem's factory and provided the product has not been subject to misuse, negligence, or accident, or repaired or altered outside of our factory, or other than by an Authorized Service Representative. This warranty does not cover the replacement of parts inoperative because of wear occasioned by use, the cost of replacing parts by a person other than an InterSystems employee or an Authorized Service Representative, or the adjustment of a product where the product was improperly adjusted by the purchaser. In addition, this warranty does not cover components manufactured by others such as motors, drives, clutches, cylinders, valves, blowers, and the like. On those components the standard Manufacturers' warranty applies. In any event, liability is limited to the purchase price paid, and InterSystems will, under no circumstances, be responsible for special or consequential damages, or for incidental damages.

INTERSYSTEMS NEITHER MAKES NOR AUTHORIZES ANY WARRANTY OTHER THAN AS HEREIN CONTAINED. THIS WARRANTY IS IN LIEU OF ALL OTHER WARRANTIES, EXPRESS OR IMPLIED, INCLUDING THOSE OF MERCHANTABILITY AND FITNESS FOR A PARTICULAR PURPOSE.