

Sampler

Model: GRA

Installation and Operation Manual

PNEG-2174

Version: 1.0

Date: 01-04-18



PNEG-2174

All information, illustrations, photos, and specifications in this manual are based on the latest information available at the time of publication. The right is reserved to make changes at any time without notice.

Contents

Chapter 1 Introduction	4
General Safety Statements	4
Scope	4
Ordering Parts	5
Replacement Parts	5
Repair Kits	5
Chapter 2 Safety	6
Safety Guidelines	6
Cautionary Symbol Definitions	7
Safety Cautions	8
Safety Sign-Off Sheet	11
Chapter 3 Decals	12
Chapter 4 General Information	15
System Description	15
Optional Features	16
Material Sampled	16
Sampler Construction	16
Chapter 5 Installation	17
Receiving Inspection	17
Pre-Installation Preparation	17
Location	17
General Mounting Guidelines	17
Material Sample Transport Lines	18
Controller Location	18
System Wiring	18
System Piping	19
Chapter 6 Operations and Adjustments	21
Control Components and their Functions	21
Pneumatic Components	25
Chapter 7 Maintenance and Repair	27
General Maintenance	27
Periodic Inspection	27
Lubrication	27
Draining and Servicing the Filter	28
Mechanical Repair Procedures	28
Chapter 8 Troubleshooting	31
General GRA Sampler Troubleshooting	31
Directional Solenoid Valve Troubleshooting	32
Air Components Troubleshooting	33
Chapter 9 Parts List	35
Sampler Model GRA Parts List	35
Chapter 10 Warranty	39

1. Introduction

This manual covers the installation and operation for the Sampler GRA Model. This manual provides guidelines for installing the product. You must retain a qualified contractor to provide on-site expertise. INTERSYSTEMS IS NOT RESPONSIBLE FOR THE INSTALLATION OF THIS PRODUCT.

InterSystems reserves the right to improve its product whenever possible and practical to do so. We reserve the right to change, improve and modify products at any time without obligation to make changes, improvements and modifications on equipment sold previously.

General Safety Statements

1. The Sampler system is designed and manufactured with operator safety in mind. However, residual hazards remain due to the nature of material handling, and specific material hazards. Use extreme caution at all times.
2. Modifications to equipment may cause extremely dangerous situations that could result in damage to the equipment as well as serious injury or death. Never modify the equipment.
3. Intersystems recommends that you contact the local power company to have a representative survey the installation to ensure wiring is compatible with their system and adequate power is supplied to the unit.
4. Consult InterSystems before making any changes to the sampler or its operating environment. Careless changes could result in death or serious injury to people and reduce the performance and service life of the equipment.
5. Never perform any service on this equipment or any powered equipment until all power has been shut off and locked out so that it cannot be restored without the consent and knowledge of the person who interrupted power. Power includes electrical, fluid, mechanical or pneumatic energy.
6. Never perform any service on this equipment without utilizing the required PPE (Personal Protective Equipment). Refer to the MSDS (s) (Material Safety Data Sheet (s)), on all the products to which this equipment is in contact to determine what PPE is required.



This equipment is to be operated only on the voltage designated on the certified electrical drawings. Fire or explosion may result, which can cause death, serious injury and extensive damage to equipment. Do not connect to voltages other than designated.



Compressed air can cause severe injury. Shut off and lock out compressed air source to the sampler and bleed off any and all present compressed air within the sampler pneumatics before attempting any service on this sampler.

Scope

The certified drawings list the non-standard components that have been incorporated into the equipment. InterSystems, Inc. normally stocks non-fabricated parts and non-custom OEM parts. Replacement parts for any other components, including fabricated parts and custom OEM components can be supplied upon request.

Ordering Parts

Direct parts orders or requests for technical assistance to your sales representative or to:

InterSystems, Inc.
 13330 "I" St.
 Omaha, NE. 68137
 Phone: (402) 330-1500
 FAX: (402) 330-3350

Please have available the MODEL NUMBER, SERIAL NUMBER and CUSTOMER ORDER NUMBER of the equipment in question as well as the location where the sampler is INSTALLED.

Replacement Parts

The InterSystems, Inc. sampler is a quality built piece of machinery. As with any machine, parts do wear out and fail. It is InterSystems recommendation that a small supply of spare parts be kept on hand to cover any minor breakdowns. A separate priced spare parts list will be sent identifying the suggested spare parts. It is also necessary to check the certified drawings, which will list any special or custom components utilized on this equipment.

Repair Kits

The following chart lists repair kits and parts that are available from InterSystems. These kits are offered as a more economical solution by rebuilding the defective part rather than replacing it. However in some cases the part may be beyond repair and replacement will be necessary.

Product Code	Description
512762	Spool Kit for 4-Way Directional Valves (ISI 375 Series)
28166	Standard 120 VAC Valve Coil and Housing (ISI 375 Series)
515835	Optional 240 VAC Valve Coil and Housing (ISI 375 Series)
519287	Optional 120 VAC Explosion-Proof Coil and Housing (ISI 375 Series)
527132	Rod Seal Kit for 5/8" Rod Air Cylinder (Parker 2MA Series)
527133	Rod Seal Kit for 1" Rod Air Cylinder (Parker 2MA Series)
523998	Piston Seal Kit for 2-1/2" Bore Air Cylinder (Parker 2MA Series)
523999	Piston Seal Kit for 3-1/4" Bore Air Cylinder (Parker 2MA Series)
524000	Piston Seal Kit for 4" Bore Air Cylinder (Parker 2MA Series)
513963	Gauge for Filter Regulator
524011	Filter Element for Filter Regulator (Norgren B08 Series)

Safety Guidelines

Safety guidelines are general-to-specific safety rules that must be followed at all times. This manual is written to help you understand safe operating procedures and problems that can be encountered by the operator and other personnel when using this equipment. Save these safety guidelines for future reference.

As owner or operator, you are responsible for understanding the requirements, hazards, and precautions that exist and to inform others as required. Unqualified persons must stay out of the work area at all times.

Alterations must not be made to the equipment. Alterations can produce dangerous situations resulting in **SERIOUS INJURY** or **DEATH**.

This equipment must be installed in accordance with the current installation codes and applicable regulations, which must be carefully followed in all cases. Authorities having jurisdiction must be consulted before installations are made.

When necessary, you must consider the installation location relative to electrical, fuel and water utilities.

Personnel operating or working around equipment must read this manual. This manual must be delivered with equipment to its owner. Failure to read this manual and its safety instructions is a misuse of the equipment.

ST-0001-3

Cautionary Symbol Definitions

Cautionary symbols appear in this manual and on product decals. The symbols alert the user of potential safety hazards, prohibited activities and mandatory actions. To help you recognize this information, we use the symbols that are defined below.



This symbol indicates an imminently hazardous situation which, if not avoided, **will result in serious injury or death.**



This symbol indicates a potentially hazardous situation which, if not avoided, **can result in serious injury or death.**



This symbol indicates a potentially hazardous situation which, if not avoided, **can result in minor or moderate injury.**



This symbol is used to address practices not related to personal injury.



This symbol indicates a general hazard.



This symbol indicates a prohibited activity.

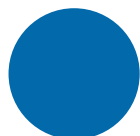

This symbol indicates a mandatory action.

ST-0005-2

Safety Cautions

Use Personal Protective Equipment

- Use appropriate personal protective equipment:

Eye Protection



Respiratory Protection



Foot Protection



Hearing Protection



Head Protection



Fall Protection



Hand Protection



- Wear clothing appropriate to the job.
- Remove all jewelry.
- Tie long hair up and back.

ST-0004-1

Follow Safety Instructions

- Carefully read all safety messages in this manual and safety signs on your machine. Keep signs in good condition. Replace missing or damaged safety signs. Be sure new equipment components and repair parts include the current safety signs. Replacement safety signs are available from the manufacturer.
- Learn how to operate the machine and how to use controls properly. Do not let anyone operate without instruction.
- If you do not understand any part of this manual or need assistance, contact your dealer.



ST-0002-1

Maintain Equipment and Work Area

- Understand service procedures before doing work. Keep area clean and dry.
- Never service equipment while it is operating. Keep hands, feet, and clothing away from moving parts.
- Keep your equipment in proper working condition. Replace worn or broken parts immediately.



ST-0003-1

Stay Clear of Hoisted Equipment

- Always use proper lifting or hoisting equipment when assembling or disassembling equipment.
- Do not walk or stand under hoisted equipment.
- Always use sturdy and stable supports when needed for installation. Not following these safety precautions creates the risk of falling equipment, which could crush personnel and cause serious injury or death.



ST-0047-1

Sharp Edge Hazard

- This product has sharp edges, which can cause serious injury.
- To avoid injury, handle sharp edges with caution and always use proper protective clothing and equipment.



ST-0036-2

Install and Operate Electrical Equipment Properly

- Electrical controls must be installed by a qualified electrician and must meet the standards set by applicable local codes (National Electrical Code for the US, Canadian Electric Code, or EN60204 along with applicable European Directives for Europe).
- Lock-out power source before making adjustments, cleaning, or maintaining equipment.
- Make sure all equipment and bins are properly grounded.



ST-0075-1

2. Safety

Stay Clear of Moving Parts

- Stay clear - machine can start without warning.
- Entanglement in gate will cause serious injury.
- Keep all shields and covers in place at all times.
- Lock-out power source before making adjustments, cleaning, or maintaining equipment.



ST-0070-1

Flying Material and High Pressure Air Hazard

- Flying material and/or high pressure air can cause severe eye injury or blindness.
- Wear safety glasses around operating equipment.



ST-0071-1

Stay Clear of Rotating Parts

- Do not service equipment while it is in operation.
- Entanglement in rotating parts or exposed belts will cause serious injury or death.
- Keep all shields and covers in place at all times.
- Lock-out power source before making adjustments, cleaning, or maintaining equipment.



ST-0072-1

3. Decals

The safety decals on your equipment are safety indicators which must be carefully read and understood by all personnel involved in the installation, operation, service and maintenance of the equipment. To replace a damaged or missing decal, contact us to receive a free replacement.

InterSystems
13330 "I" Street
Omaha, Nebraska 68137
Phone: (402) 330-1500
FAX: (402) 330-3350

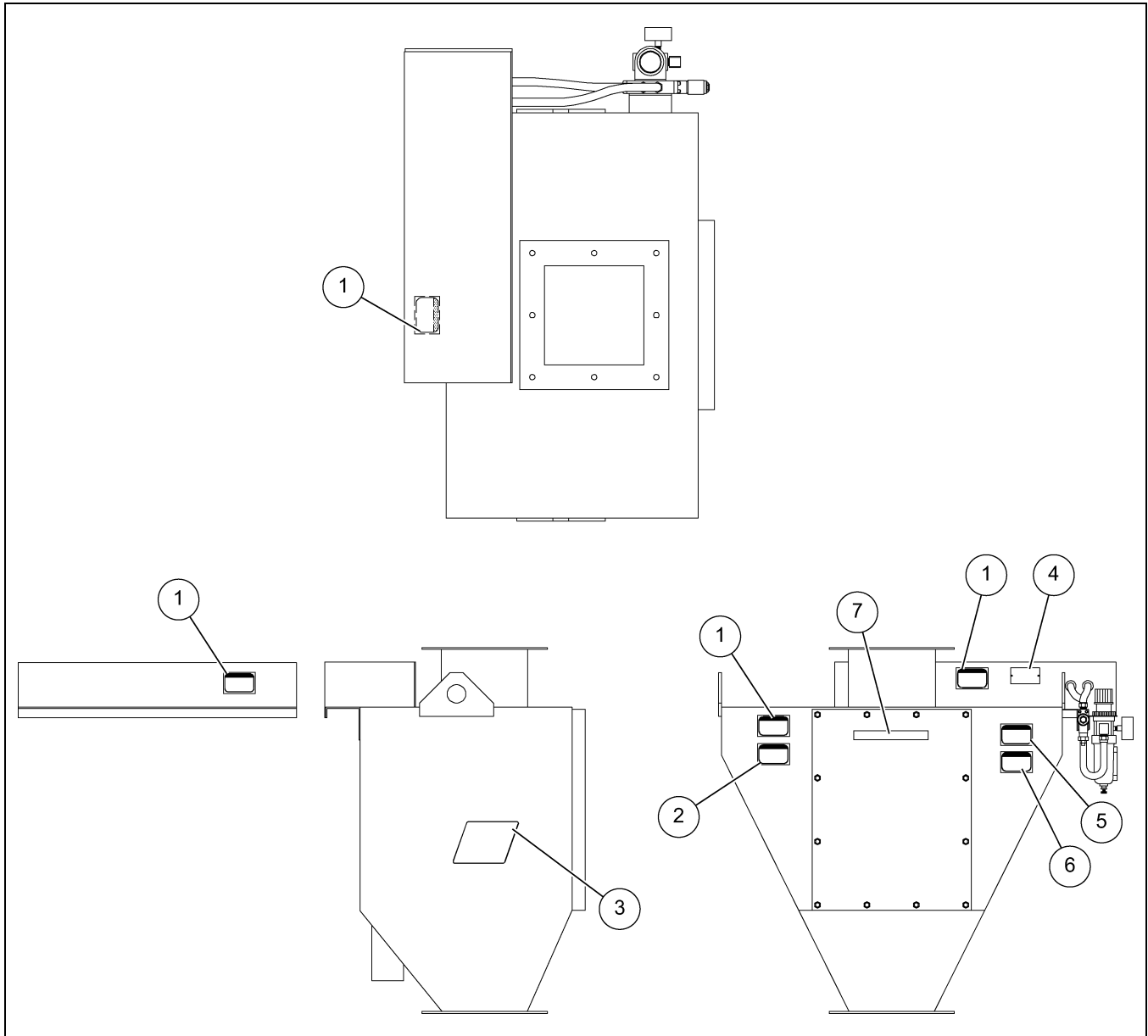
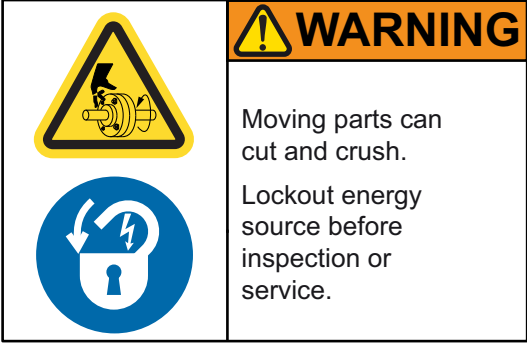







Figure 3A GRA Sampler Safety Label Locations

NOTE: These signs must never be removed, tampered with, painted over or obscured in anyway. If labels are damaged or become unreadable, replacement labels are available from InterSystems.

Ref #	Decal #	Decals	Description
1	EMC3034	 <p>© Clarion Clarionsafety.com Recorder No. EMC 3032</p>	Moving Part
2	EMC42834	 <p>© Clarion 15225 No. EMC 28 34</p>	Eye Protection
3	IS526X4		IS Logo

3. Decals

Ref #	Decal #	Decals	Description
4	IS Tag	 <p>The decal features the InterSystems logo (IS with GSI) at the top. Below it, the text reads "InterSystems, Inc." followed by "13330 I STREET OMAHA, NEBRASKA 68137". At the bottom, there are two circular punch holes and the words "MODEL" and "SERIAL" in bold, black, sans-serif font.</p>	Serial Number Tag
5	EMC40234	 <p>The decal is divided into two main sections. On the left, there is a yellow triangular warning sign with a black exclamation mark, and below it, a blue circular sign with a white padlock and a lightning bolt, indicating electrical safety. On the right, there is an orange header with a white exclamation mark icon and the word "WARNING" in bold. Below the header, the text reads "Avoid serious injury or death." followed by "This machine MUST be locked out in accordance with current OSHA requirements before any maintenance or service is performed." At the bottom, there is small text: "© Clarion clarionsafety.com 16089 Reorder No. EMC 402 34".</p>	Lock Out Machine
6	EMC40334	 <p>The decal is divided into two main sections. On the left, there is a red circular prohibition sign with a black hand icon, and below it, a yellow triangular warning sign with a black circular arrow icon. On the right, there is an orange header with a white exclamation mark icon and the word "WARNING" in bold. Below the header, the text reads "Stay clear." followed by "Machine starts without warning." At the bottom, there is small text: "© Clarion clarionsafety.com Reorder No. EMC 403 34".</p>	Starts Without Warning
7	IS 516x1	 <p>The decal features the InterSystems logo (IS with GSI) on the left. To its right, the text reads "InterSystems Samplers" in bold. Below this, it says "OMAHA, NEBRASKA DALLAS, TX. IS 516X1".</p>	IS Samplers

System Description

The GRA Sampler is designed to collect a representative sample of granular, flake, pellet, slurry or other materials in a vertical gravity conveying line.

Sample collection is initiated in response to either an operator's manual command or a signal automatically generated by controller logic, usually time-based but which could also be volume or quantity based. A sample cycle begins when a double-acting pneumatic cylinder pivots the slotted sample cutter through the product flow to collect a sample of the material. The sample flows through the sample cutter and out the discharge as it swings through the material flow. The sample cutter, when at rest, is situated under one of two dust seals that seal the sample cutter. The sample from the sample cutter falls down and out the 3.00" (76 mm) O.D. discharge tube to the desired sample collection point, at which point an InterSystems SCS Sample Collection System (optional) may be installed.

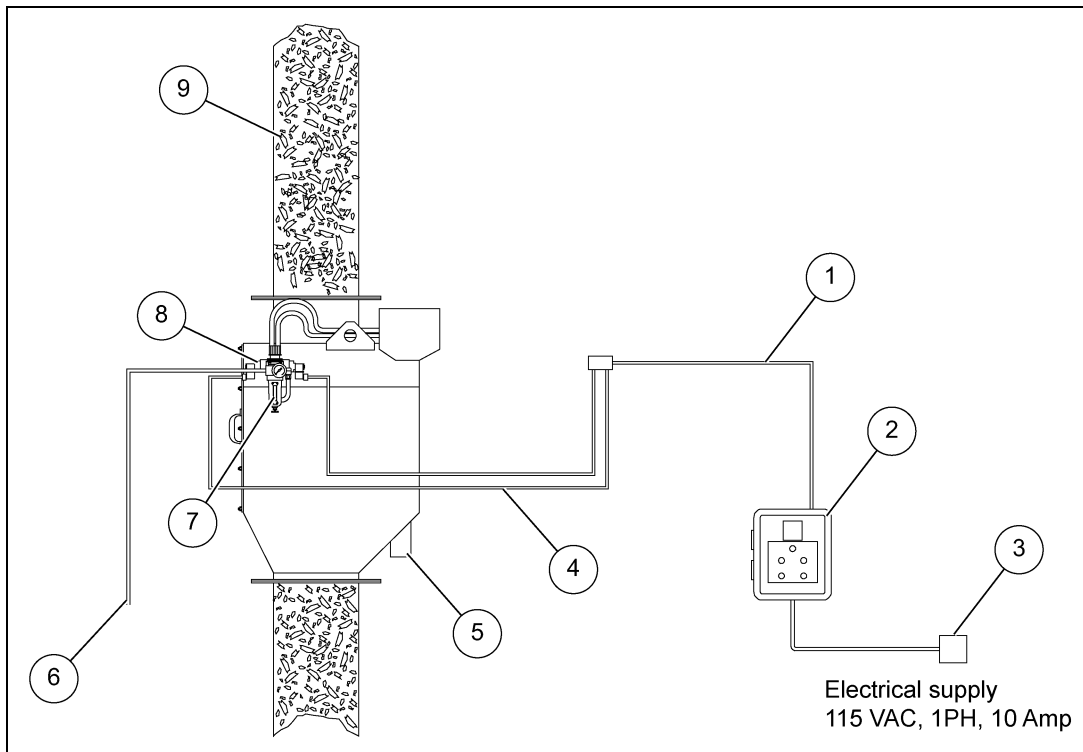

Figure 4A Typical Installation, Model GRA Sampling System

Ref #	Description
1	Electrical Conduits
2	Sampler Control Panel
3	Circuit Breaker
4	Directional Control Valve Coils (2)
5	Sample Discharge (Extend to desired collection point)
6	1/2" NPT Compressed Air Line 80-100 PSI Compressed Air Supply. Required (By others)
7	Filters/Regulator
8	Dual Coil Solenoid Control Valve
9	Material to be Sampled

4. General Information

Optional Features

The certified drawings indicate which, if any, optional features are included with a sampling system. Some of the more frequently specified optional features are briefly described in the following list.

1. Controller arranged to initiate a sampling cycle based on quantity or volume of material passing through conveying line rather than upon elapsed time periods.
2. Explosion-Proof Sampling System. There are several major differences in an explosion-proof sampler as compared to a standard sampling system. An explosion-proof sampler will typically have the following features.
 - a. An explosion-proof solenoid on the directional control valve with the rating of:
Class 1, Groups C and D, Division 1 and 2
Class 2, Groups E, F and G, Division 1 and 2
The explosion proof sampler control is available in two enclosure classifications.
 - a. The NEMA 9 control with the rating of:
Class 2, Groups E, F and G, Division 1 and 2
 - b. The NEMA 7 control with the rating of:
Class 1, Groups C and D, Division 1 and 2
Class 2, Groups E, F and G, Division 1 and 2
3. Positive mechanical seals for sealing the sample cutter when slight conveying line pressures are present.
4. Components of special materials, such as 316 stainless steel, monel, inconel or nedox coatings.
5. Programmable controls to sequence the sampler and the sample collection equipment.
6. Abrasion resistant linings of urethane, AR carbon steel plate, 304 stainless steel or ceramic tile.

Material Sampled

Most materials from light to heavy density granules, flakes, pellets, powders and slurries.

Sampler Construction

Standard sampler construction is of painted carbon steel or Type 304 Stainless Steel. Other materials and/or finishes appropriate to the operating environment and the material or product being sampled may be used. Refer to the certified drawing(s) for any optional or special components installed on the sampler.

Receiving Inspection

Carefully inspect the sampling system for damage as soon as it is received. Also, verify that the quantity of parts or packages actually received corresponds to the quantity shown on the packing slip. Report any damage or shortage to the delivering carrier as soon as possible. InterSystems responsibility for the equipment ended with acceptance by the delivering carrier. Refer to the bill of lading.

Pre-Installation Preparation

NOTE: *Before starting sampling system installation, study this manual, the certified drawing(s) furnished with the system and other applicable documents (including, but not limited to OSHA Regulations, the National Electrical Code and all other applicable federal, state and local codes and regulations).*

Location

The GRA sampler is typically mounted vertically into a gravity flowing conveying line carrying the product to be sampled as shown in [Figure 4A on Page 15](#). The sampler axis must be installed parallel to the axis of the product line for optimum performance. Additionally, the sampler should be located where the product has a non-turbulent flow pattern. The sampler and associated equipment should be located for ease of access and maintenance.

The sampler is to be installed only as shown on the certified drawing(s). If an alternate mounting arrangement is desired contact InterSystems prior to installation for proper guidance. The sampler is of a general design with modifications specifically for your application. It may be necessary to rework the sampler in order for it to function properly if you alter the application.

General Mounting Guidelines



Sampler cannot support any other equipment or conveying line. Collapse of the whole system can cause death, serious injury and extensive damage to equipment. Properly support all spouts, containers and conveying lines.

1. Locate and mark the desired mounting location of the sampler on the product conveying line.
2. Cut out the section of conveying line 1/16" to 1/8" longer than the length of the sampler.
3. Slip a companion flange over each end of the conveying line.
4. Locate the sampler in the desired position and adequately brace. Braces are to be permanent.
5. Bolt the companion flanges to the sampler and weld companion flanges to the chute.

5. Installation

Material Sample Transport Lines

The tubing used to transport material samples must be compatible with the operating environment and the material sampled. Typically a 3.00" I.D. flexible hose is slipped over the discharge tube and held in place by a worm clamp. The hose is then routed to allow material to flow via gravity to a convenient collection point. At that point, the hose may be connected to a collection jar bracket or a Sample Collection System cabinet.

Rigid tubing may also be used if desired for the sample transport line.

Make all connections airtight and make sure all interior surfaces of joints are smooth and flush. Any ragged or raised tube ends will collect dust and debris as well as retard material flow. Air leaks can interfere with the pressure or vacuum conveying and sampling system. Escaping sample material can contaminate surrounding atmosphere and equipment.

Controller Location

1. Use vibration isolation pads when mounting the control enclosure or mount the controller in a vibration free location.
2. Unless ordered for severe duty, locate controller so it is protected from water and dust.
3. Unless an explosion-proof rated controller was specifically ordered, DO NOT locate the controller in a hazardous area.
4. Most applications require that the sampler be in easy view of the controller.

System Wiring

Refer to the certified electrical drawing(s) for specific wiring requirements.

The controller was completely assembled and tested with the sampler before it left the factory. The electrical installation must comply with OSHA Regulations, the National Electrical Code and all other applicable federal, state and local codes and regulations.

If wiring between the controller and the sampler unit is run through rigid conduit, use a short length of flexible conduit to connect wiring to the sampler. This will isolate the rigid conduit from any vibration originating in the product conveying line and sampler.

Electrical Power Requirements, System

110/120 VAC 50/60 Hz, Single Phase, 10 Amp Service.

Optional - 220/240 VAC 50/60 Hz, Single Phase, 5 Amp Service.

Refer to the certified electrical drawing(s) for specific wiring requirements. InterSystems strongly recommends that electrical service to the sampling system be an isolated line. Voltage fluctuations and line noise can affect the controller's circuit board, thus causing the sampler to malfunction.

Controller

110/120 VAC, 50/60 Hz, Single Phase, 4 Amp Max. (Includes motor power requirements).

Optional - 220/240 VAC, 50/60 Hz, Single Phase, 2 Amp Max. (Includes motor power requirements).

Solenoid Valve Coil

110/120 VAC, 50/60 Hz, Single Phase, 7 Watts.

Optional - 220/240 VAC, 50/60 Hz, Single Phase, 7 Watts.

System Piping



Use only cleaned, pickled, descaled and oiled pipe for air supply lines. Dirt, scale and debris usually found in standard pipe quickly clogs filter/regulators, valves, etc. Use only Teflon tape to seal pipe joints. Carefully apply the tape to pipe and fittings so no fragments enter the system.

The pneumatic system was pre-plumbed and tested with the sampler before it left the factory. The final installation must comply with OSHA Regulations and all other applicable federal, state and local codes and regulations.

As shown on the certified drawing(s), the solenoid valves and filter/regulator (F/R) were mounted on the sampler at the factory. The user or installer must pipe the compressed air supply to the F/R. Minimum pipe size for the air supply to the filter/regulator is 1/2" NPT, reduced to 3/8" NPT at sampler. Larger piping to the sampler and/or a surge tank located at the sampler, will be required on installations where the compressed air source is further than 200' from the sampler to prevent excessive drop in air pressure.

InterSystems recommends installing a shut off valve upstream of the filter/regulator. A shut off valve facilitates maintenance as it allows the sampler's pneumatic system to be maintained and repaired without shutting down other equipment supplied from the same air source.

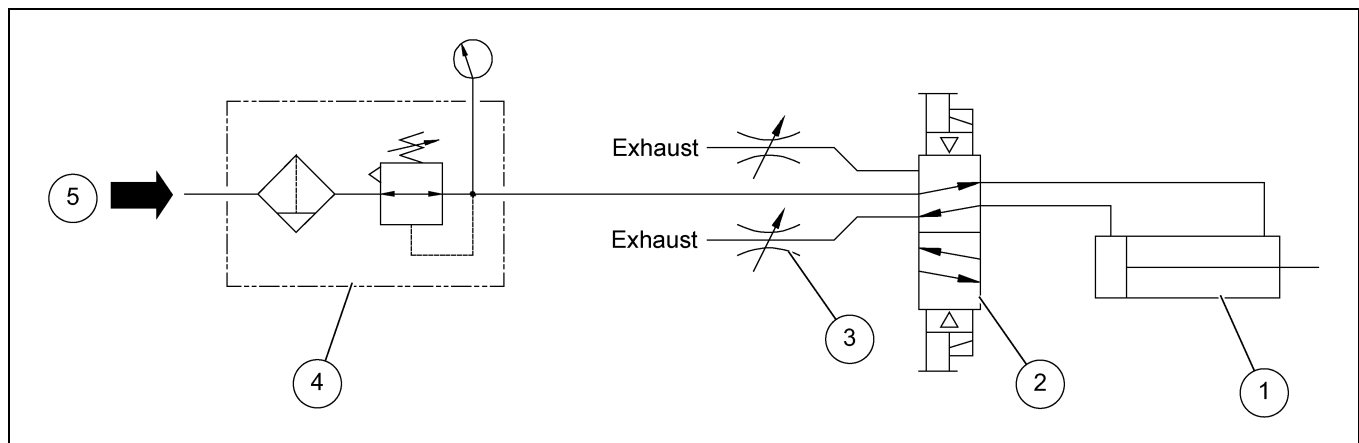

Figure 5A Pneumatic Schematic

Ref #	Description
1	Extend/Retract Cylinder
2	4-Way Directional Solenoid Valve
3	Needle Valves (Speed Control)
4	Filter Regulator
5	Compressed Air "In"

5. Installation

Compressed Air Consumption

A complete sampling cycle requires that the sample cutter drive cylinder either extend or retract. To determine the compressed air requirements to operate the sampler, multiply the consumption per cycle (refer to chart) by the number of cycles per minute. The number calculated is the SCFM (Standard Cubic Feet per Minute) of air required. A typical cycle takes between 1-2 seconds, depending on the sampler size and speed control valve settings.

The pneumatic system on the sampler, consisting of the filter/regulator, directional control valve and air cylinder was pre-plumbed and tested at the factory. The regulator is factory set at 80 PSI.

The regulator cannot increase downstream outlet pressure above the upstream inlet pressure. If the pressure from the regulator is not sufficient to operate the cylinder, some means must be found to increase the inlet pressure to the regulator. Recommended air supply pressure is 80-100 PSI.

Model/Size	Air Consumption per Sample Cycle @ 80 PSI
GRA-6 and 10	0.36 SCF
GRA-14 and 18	0.59 SCF
GRA-22, 26 and 30	0.91 SCF



Failure to observe all safety rules, written and implied and those suggested by common sense, can result in death, serious injury and/or equipment damage. Lock out power before performing any maintenance.

Control Components and their Functions

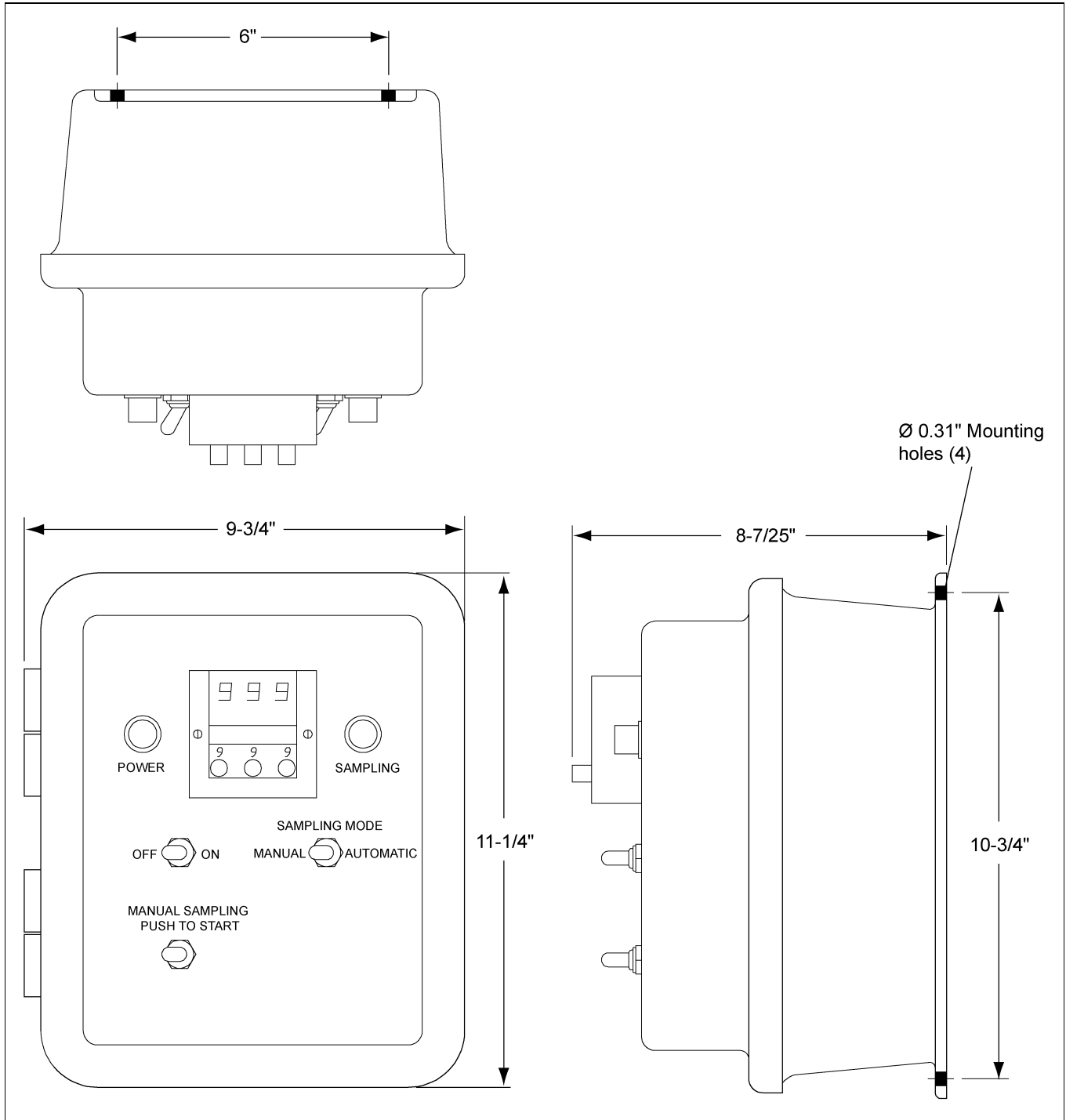

Figure 6A Standard Nema 4 Control Panel Detail

Refer to the certified electrical drawing(s) for dimensions on control panels with optional features.

6. Operations and Adjustments

Power OFF/ON Switch S-2

This toggle switch controls all electrical power to the controller and the sampler unit.



This machine starts without warning. Moving parts can cause severe injury. Clear area prior to controller start-up.

Sampling Mode Switch S-3 (Automatic/Manual)

This switch permits the operator to select whether samples will be collected automatically at precisely timed or counted intervals as determined by the Digital Display Timer (T-1) or Counter C-1 or manually whenever the operator momentarily actuates the MANUAL SAMPLING toggle switch (S-4).

Manual Sampling Switch S-4

This switch functions ONLY when the AUTO/MANUAL switch has been set to the Manual Mode position. Switch S-4 is a spring-return switch that is maintained in the OFF or Normally Open position. Correct operating procedure is to momentarily actuate S-4 to the Start position. When the SAMPLING light is illuminated, release the switch. The sampler will complete its cycle without further operator intervention.

Power Pilot Light

This light is illuminated as long as power is available to the controller and the POWER switch (S-2) is set to ON.

Sampling Pilot Light

This light will illuminate when the sample pelican is traversing thru the product flow.

Digital Display Timer T-1 (Standard)

As arranged for use in this system, the timer operates in the DOWN and STOP mode. When the AUTO mode is selected, the illuminated display resets to the value dialed in to the Three Digit Preset. Immediately, the timer begins timing down. When the illuminated display reads all zeroes (000), the timer has “timed out” and initiates a sampling cycle. The sample pelican traverses thru the product flow to collect a sample. The timer display resets to the preset value and another timing interval is initiated. If the controller is shut off or the mode switched from AUTO to MANUAL, the timing cycle is terminated. When power is restored or the AUTO mode is again selected, the display is reset to the preset value and another cycle begins. **NOTE:** *A new timing cycle can be initiated ONLY after the sampling cycle has completed.*

1. External Settings

a. The Display:

The high intensity blue fluorescent display consists of three digits and decimal point (if decimal is set in tenths or hundredths position). Also, there is a blinking Timing Bar and a special Time-Out symbol. The Timing Bar appears to the right of the digits and blinks once every second during timing. The Timing Bar shows quickly that the timer is actively timing especially when the digits do not change rapidly as in the “hours” ranges. When the delay relay is energized at time-out, a triangular Time-Out symbol appears to the left of the digits. The Timing Bar blinks noticeably faster at time-out.

b. Setting Switches:

The three digits are set with the rotary switch knobs located beneath each digit. These knobs can be rotated in either direction (CW or CCW) and they are “pull” removable if digit set security is desired. Changing one or more digits, during timing, will instantly be reflected by an equivalent change in the timer’s display. Setting all three digits to zero will cause instant time-out of the timer.

2. Internal Settings

The 365 digital display timer must be removed from its housing to alter any of the following settings.

a. Time Range:

Decimal Point Location can be changed with the white plastic lever mounted behind the front face of the timer. This lever moves into three positions. With finger force you can change its position and at the same time observe the front of the timer. **NOTE:** *This procedure sets the decimal point electronically as well as visually.*

Time Units (Sec/Min/Hr) are set by moving a small width metal arm in a slotted arc on the side plate nearest to the units (Sec/Min/Hr) window. By depressing this arm slightly with a pencil or pen point, it can be moved to a new position. The time units physically change in the timer’s face and the timer is electronically switched to the new units as well.

b. Line Frequency:

To set the proper line frequency, connect the jumper wire to either the 50 Hz or 60 Hz pin. These pins are clearly marked on the side of the timer.

NOTE: *The timer chassis and the housing are polarized so that the chassis cannot be inserted into its housing upside-down. If the timer is forced into the housing upside-down damage will result.*

Digital Display Counter C-1 (Optional)

As arranged for use in this system, the counter operates in the DOWN and STOP mode. When the AUTO mode is selected, the illuminated display resets to the value dialed in to the Three Digit Preset. Immediately, the counter begins counting down. When the illuminated display reads all zeroes (000), the counter has “counted out” and initiates a sampling cycle. The sample pelican traverses thru the product flow to collect a sample. The counter display resets to the preset value and another counting interval is initiated. If the controller is shut off or the mode switched from AUTO to MANUAL, the counting cycle is terminated. When power is restored or the AUTO mode is again selected, the display is reset to the preset value and another cycle begins. **NOTE:** *A new counting cycle can be initiated ONLY after the sampling cycle has completed.*

1. External Settings

a. The Display:

The high intensity blue fluorescent display consists of three digits and a Counting Bar with a special Count-Out symbol. The Counting Bar appears to the right of the digits and blinks once every count, regardless of range. When the delay relay is energized at count-out, a triangular Count-Out symbol appears to the left of the digits.

b. Setting Switches:

The three digits are set with the rotary switch knobs located beneath each digit. These knobs can be rotated in either direction (CW or CCW) and they are “pull” removable, if digit set security is desired. Changing one or more digits, during counting, will instantly be reflected by an equivalent change in the counter’s display. Setting all three digits to zero will cause instant count-out of the counter.

6. Operations and Adjustments

2. Internal Settings

The 366 digital display counter must be removed from its housing to alter the count range.

The 366 has three ranges.

- 1x = Counts single pulses to 999
- 10x = Counts every tenth pulse to 9,990
- 100x = Counts every hundredth pulse to 99,900

Each range is selectable using finger force on the white plastic lever behind the front face of the counter. In two of the three possible lever positions, an indicator will appear in a range window located on the front face of the counter. When nothing appears in this window the count is in the x 1 range.

NOTE: *The counter chassis and the housing are polarized so that the chassis cannot be inserted into its housing upside-down. if the counter is forced into the housing upside-down damage will result.*

Off Delay Timer T-2

This internal timer starts timing after the sample timer T-1 or counter C-1 has signalled to take a sample. This timer turns on the sampling light to indicate a sample is being taken. An approximate setting of 1 to 3 seconds is required to provide an indication that a sample is being taken.

Main Fuse

This fuse, located in a fuse block within the controller enclosure, protects the controller and sampler components against overloads and short circuits.

For 110/120 VAC, 1 PH operation use **ONLY** a Buss Type FNM, 4 Amp, 250 Volt Slo-Blo fuse or equal.
For 220/240 VAC, 1 PH operation use **ONLY** a Buss Type FNM, 2 Amp, 250 Volt Slo-Blo fuse or equal.

Index Relay IR-1

This mechanical latching relay signals the sampler solenoid valve V-1 coils. When the relay coil receives a momentary signal from either the timer T-1 or the manual sample switch the maintained switch contacts change to the alternate position. Upon changing position, the opposite solenoid valve coil receives power, the valve spool switches and a sample is taken.

Terminal Strip

This 10-position barrier terminal strip serves as the controller's interface and connection point for all external circuits and for the components mounted on the enclosure's front panel. Refer to the certified electrical drawing(s).

Pneumatic Components

Sample Cutter Traverse Valve V-1

This valve is a 4-way, 2 position, dual solenoid operated control valve. This valve controls the air cylinder, alternately pressurizing one side or the other of the air cylinder to traverse the sample pelican. The valve has two manual over-ride buttons that allows the operator to cycle the sample cutter traverse air cylinder without the aid of the controller. By pushing a manual over-ride button, the internal valve spool is positioned manually and the sample pelican will traverse to the other side.

NOTE: *The manual over-rides will only work when the control power is OFF.*

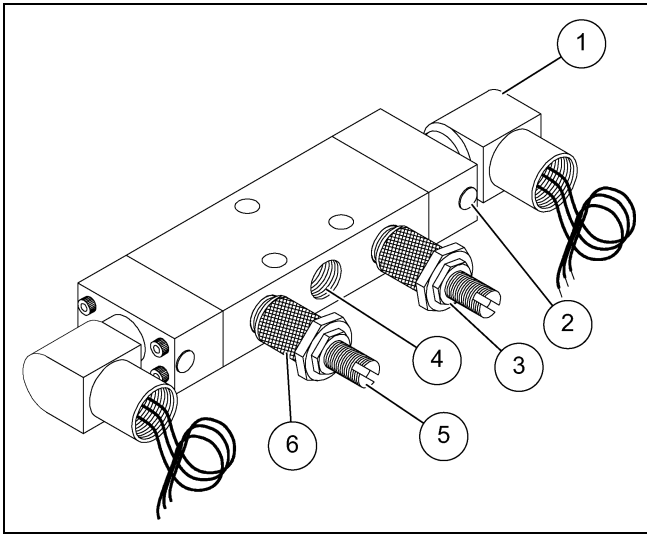

Ref #	Description
1	Solenoid
2	Manual Over-Ride
3	Metering Screw Lock Nut
4	Air Supply Port
5	Flow Control Metering Screw
6	Mesh Screen

Figure 6B Solenoid Valve

Speed Control Valves

A speed control valve is threaded into each exhaust port of Valve V-1. (See Figure 6B.) Each speed control valve controls the rate at which air exhausts from one end of the cylinder and as a result, controls cylinder operating speed in only one direction. The speed controls were factory set but may need minor adjustment due to differences in air supplies. Use the following guidelines when adjusting the speed controls.



Escape of pressurized air, fluids and contaminants at high velocity can cause injury to unprotected eyes. Always wear eye protection when servicing air valves and components.

1. Turn the nut locking the one speed control valve's metering screw clockwise to loosen it. (**NOTE:** *Left hand threads.*) Do not allow metering screw to turn.
2. Change control switch to manual mode and initiate a manual sample. While operating the sampler, turn the metering screw to vary the speed of cylinder operation. Turn the screw clockwise to decrease speed or turn the screw counterclockwise to increase speed.
3. When the desired cylinder operating speed in one direction has been achieved, tighten the nut to lock the adjustment and repeat procedure to adjust the other speed control valve.

6. Operations and Adjustments

Air Filter/Pressure Regulator

The air filter/regulator assembly provides a clean and regulated air supply to the samplers pneumatic components. A pressure gauge gives the operator an accurate reading of the downstream air pressure. The regulator is equipped with an adjustment knob for controlling the outlet pressure and a manual “pet-cock” type drain for draining the filter bowl.

Prior to introduction of air supply, turn the adjustment knob counterclockwise until all load is removed from the regulating spring. Turn ON system air pressure. Turn adjustment knob clockwise until desired outlet pressure is reached.

To avoid minor re-adjustments after making a change in the pressure setting, always approach the desired setting from a lower pressure. When reducing from a higher setting to a lower setting, first reduce to a pressure setting lower than desired and then adjust upward.

To “lock-in” the pressure setting on the regulator, push the locking on the adjustment knob down until it snaps into place. To release pull the locking upward. The pressure setting can be made tamper resistant by installing a seal wire in the groove above the locking.

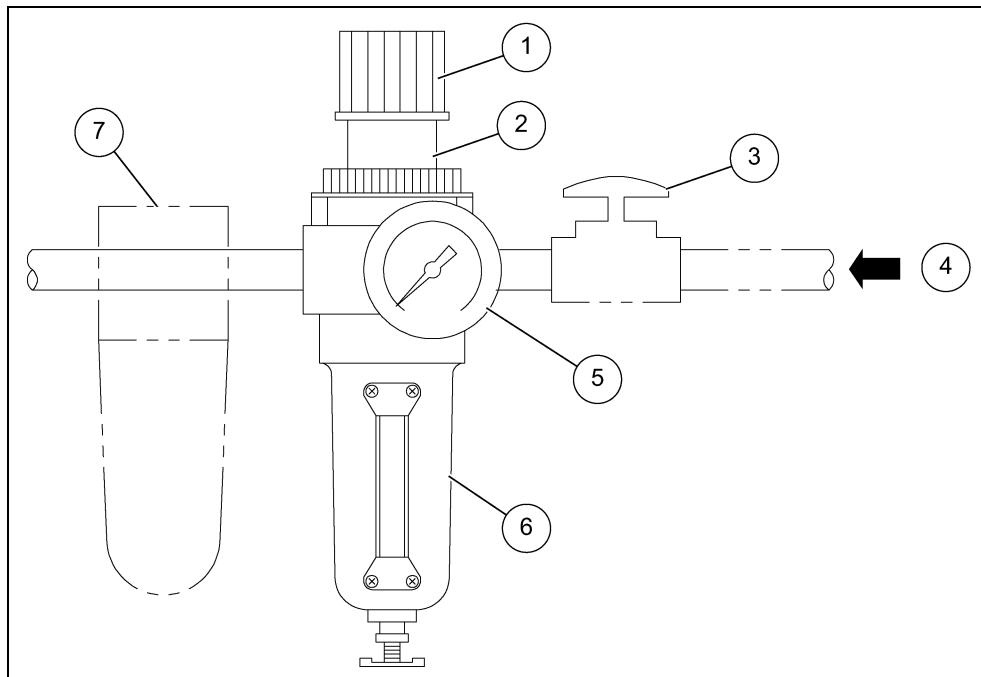

Figure 6C Filter/Regulator

Ref #	Description
1	Adjustment Knob
2	Air Regulator
3	Shut Off Valve (Optional)
4	Flow

Ref #	Description
5	Air Pressure Gauge
6	Air Filter and Bowl with Sight Glass
7	Lubricator (Optional)

Pneumatic Cylinder (Sample Cutter Drive)

This double-acting air cylinder pivots the sample cutter either left or right thru the product flow. The cylinder rod is direct connected to the sample pelican. Solenoid valve V-1 controls positioning of this cylinder.



Failure to observe all safety rules, written and implied and those suggested by common sense, can result in death, serious injury and/or equipment damage. Lock out power before performing any maintenance.

General Maintenance

A good maintenance program involves thorough general housekeeping, adequate periodic re-lubrication and replacement of worn or damaged components.

Periodic Inspection

At regularly scheduled intervals, while observing all safety precautions, observe the sample as it operates. Inspect for:

1. Loose or missing hardware
2. Adequate lubricant in lubricator
3. Structural damage
4. Rust or corrosion
5. Damaged wiring, including exposed conductors and connections
6. Damaged airlines or pneumatic components
7. Make sure that all guards are in place and that all warning labels are in place and legible.
See Page 7, GENERAL SAFETY INFORMATION, explains the purpose and intended location of the warning signs. Warning signs are an important part of any safety program, replace any missing signs IMMEDIATELY.

Lubrication

Airline Lubricator

An airline lubricator is not required. The cylinder is of a non-lube design requiring NO lubrication. If the use of a lubricator is desired, it must be field mounted between the F/R and the directional control valve. If a lubricator has been added to the system, the user must determine the appropriate lubricant and the proper intervals for refilling the reservoir. Refer to the manufacturer's technical literature. Note that by introducing oil into the airline, it will be discharged into the surrounding environment near the air exhausts of the directional control valve(s) on the sampler.

Draining and Servicing the Filter



Escape of pressurized air, fluids and contaminants at high velocity can cause injury to unprotected eyes. Always wear eye protection when draining a filter.

Drain the accumulated fluid whenever the fluid level in the reservoir (quiet-zone) rises to the lower baffle. Filters have either a screw-type drain or a push-type drain. If the filter requires frequent draining, consider installing an automatic drain or an air drying system. Periodically, the bowl may need to be removed to clean out accumulated moisture and contaminants.

1. Shut off and lock out the air supply.
2. Operate a valve or loosen an airline connection to relieve all pressure downstream from the filter/regulator.
3. Remove and clean the bowl, various types of clamp rings or threaded collars are used to retain bowls.

NOTE: *The bowls of filter/regulators can not be removed while pressurized. Internal pressure prevents the clamp ring or threaded collar from turning.*

4. Clean or replace the filter element.
5. If the bowl seal is damaged or brittle replace it. In any event lightly coat the seal with petroleum-based grease to help hold it in position.
6. Re-install the bowl. Turn ON pressure and make sure the bowl is seated and sealed.

Mechanical Repair Procedures

Sample Cutter Blade Replacement

When following the instructions below, refer to the applicable drawing of the sampler. Reference the section drawings of the samplers [on Pages 35 and 36](#) and the certified drawing(s).

1. Shut off and lock out all power (electrical and pneumatic).
2. Shut down conveying line and remove the large inspection cover on the sampler housing.
3. Move the sample pelican to the middle of its travel.
4. Remove the 1/4"-20 UNC hex head bolts fastening the sample cutter to the sample pelican.
5. Using a utility knife, cut the caulking seal around the bottom of the cutter blade and remove.
6. Note the taper of the cutter blade opening. Install the new cutter blade on the sample pelican with narrow part nearest the drive shaft.
7. Re-install the 1/4"-20 UNC hex head bolts fastening the sample cutter to the sample pelican.
8. Re-caulk the joint between the cutter blade and the sample pelican to ensure a tight seal.
9. Move the sample pelican to its home position on each side and check to see that the cutter fits snugly under the pelican seals.
10. Re-install the inspection cover on the housing.
11. Restore power to the sampler and operate it through several collection cycles.

Sample Cutter Seals Replacement

When following the instructions below, refer to the applicable drawing of the sampler. Reference the section drawings of the samplers [on Pages 35 and 36](#) and the certified drawing(s).

1. Shut off and lock out all power (electrical and pneumatic).
2. Shut down conveying line and remove the large inspection cover on the sampler housing.
3. Move the sample pelican to the middle of its travel.
4. Remove the 5/16"-18 UNC hex head nuts fastening the sample cutter seal brackets the sampler housing (avoid dropping the assemblies inside the sampler).
5. Wrap the new seals around the seal brackets and re-install.
6. Move the sample pelican to its home position on each side and check to see that the cutter fits snugly under the pelican seals.
7. Re-install the inspection cover on the housing.
8. Restore power to the sampler and operate it through several collection cycles.

Drive Arm Positioning and Torque Hub Tightening

When following the instructions below, refer to [Figure 7A](#) and the section drawings of the samplers [on Pages 35 and 36](#) the certified drawing(s).

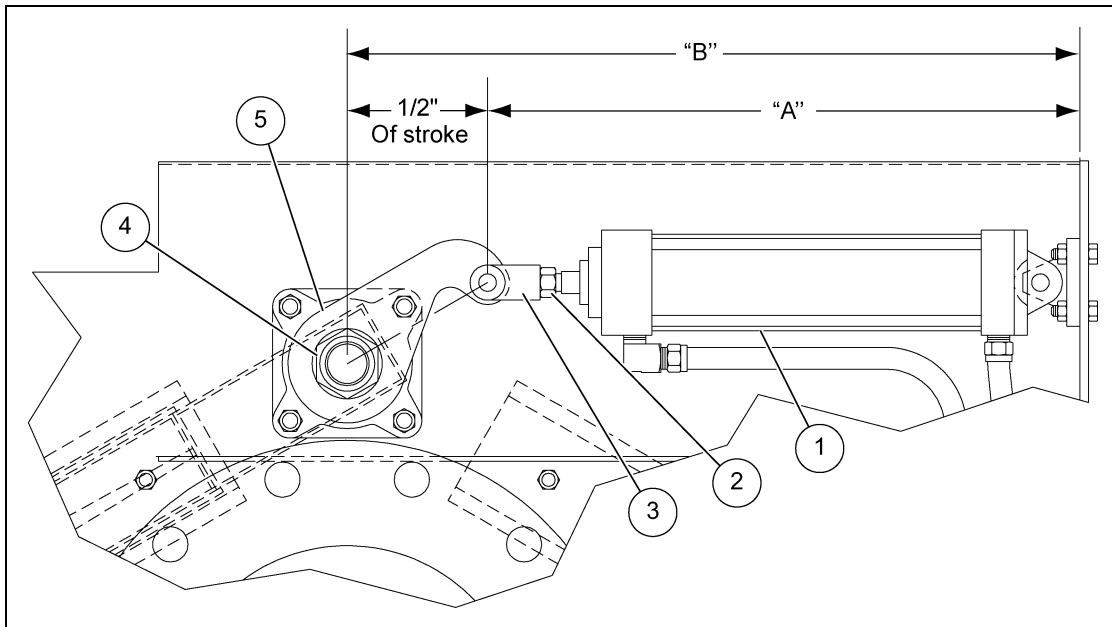

Figure 7A Model GRA Drive Arm and Torque Hub

Ref #	Description
1	Air Cylinder
2	Jam Nut
3	Rod Clevis

Ref #	Description
4	Torque Hub
5	Drive Arm

7. Maintenance and Repair

1. Hand tighten the torque hub nut until the assembly begins to snug up in the bore of the drive arm and the shaft of the sample pelican.
2. Measure the "B" dimension and position the rod clevis on the air cylinder so that the "A" dimension is the same as the "B" measurement less 1/2" of the stroke.
3. The rod threads on the air cylinder will need to be shortened if they protrude inside the clevis and hit the drive arm. Lock clevis in place by tightening the jam nut.
4. Check the position of the drive arm on the shaft with the alignment of the sample pelican. The air cylinder must remain parallel to the top of the housing as it extends and retracts. Retract the air cylinder and check that the sample cutter seals under the dust seal. Extend the air cylinder and check the opposite seal.
5. Tighten the torque hub nut with a torque wrench to the value shown on the table below.

Sampler Size	Shaft Size	Nut Size	Installation Torque On Nut
GRA-6 and GRA-10	1-1/4"	1-3/4"	1800 In./Lbs. (150 Ft./Lbs.)
GRA-14 and GRA-18	1-1/2"	2.00"	2100 In./Lbs. (175 Ft./Lbs.)
GRA-22 and GRA-26	1-15/16"	2-1/2"	3500 In./Lbs. (290 Ft./Lbs.)

General GRA Sampler Troubleshooting



Careless or accidental restoration of power can result in death or serious injury. Make certain area is clear before removing lock outs.

Symptom	Possible Cause	Corrective Action
Sample does not cycle in either auto or manual modes (Power light OFF).	Power switch OFF.	Turn power switch ON.
	Circuit breaker is open.	Reset breaker.
	Main fuse is blown.	Replace. (See Main Fuse on Page 24.)
	Faulty supply wiring.	Correct. Refer to certified electrical schematic.
	Defective power switch.	Replace switch.
Sample does not cycle in either auto or manual modes (Power light ON).	Faulty system wiring.	Correct. Refer to certified electrical schematic.
	No or low air pressure.	Turn air supply on and set regulator to 80-100 PSI.
	Defective control valve.	See Directional Solenoid Valve Troubleshooting on Page 32.
Sampler timer T-1 digital display does not illuminate but sampler works in manual mode.	Defective auto/manual switch S-2.	Replace switch if line voltage is absent across #1 and #2 on timer T-1.
	Defective timer T-1.	Replace switch if line voltage is absent across #1 and #2 on timer T-1.
Sample size too small or large.	Speed control valves set too low or too high.	Adjust speed control valves. (See Speed Control Valves on Page 25.)
	Sample cutter opening too small or large.	Replace. (See Sample Cutter Blade Replacement on Page 28.)
	Sample interval timer or counter set too high or low.	Adjust sample interval timer T-1 or counter C-1. (See Digital Display Timer T-1 (Standard) on Page 22.) or (See Digital Display Counter C-1 (Optional) on Page 23.)
Sampler leaks air or material continuously out the sample discharge.	Sample cutter seals torn or missing.	Replace. (See Sample Cutter Seals Replacement on Page 29.)
	Sample cutter not stopping under the dust seals.	Adjust torque hub. (See Drive Arm Positioning and Torque Hub Tightening on Page 29.)
	Sampler installed on a positive pressure line.	Remove pressure by venting sampler or consult InterSystems.
	Sample cutter worn.	Replace. (See Sample Cutter Blade Replacement on Page 28.)
Sampler sluggish (Operates too slowly).	Inadequate air supply.	Increase line size or add surge tank.
	Regulator set too low.	Reset. (See Air Filter/Pressure Regulator on Page 26.)
	Filter clogged.	Clean as outlined in Section. (See Draining and Servicing the Filter on Page 28.)
	Airline from filter regulator blocked or damaged.	Inspect and correct.
	Cylinder seal leakage.	See Air Components Troubleshooting on Page 33.

8. Troubleshooting

Directional Solenoid Valve Troubleshooting

Symptom	Possible Cause	Corrective Action
Valve does not shift but 120 VAC signal is present at the terminal strip inside the control.	No or low air pressure.	Turn ON air supply and set regulator to 80-100 PSI.
	Faulty field wiring.	Check for full line voltage at the solenoid.
	Solenoid coil burnt out.	Replace coil if no continuity through coil.
	Valve clogged or stuck.	Remove and clean. Or replace.
Valve leaks air continuously out an exhaust port.	Defective valve seals.	See Valve vs. Cylinder Leak Test on Page 34.
	Defective cylinder seals.	See Valve vs. Cylinder Leak Test on Page 34.

There must be at least 60 PSI pressure at the valve. The valve pilot operators are air assisted. If there is insufficient pressure the valve will not shift or may not shift completely.

Observe the pressure gauge. Assume the gauge indicates sufficient pressure when the sampler is idle, 85 PSI for example. If the pressure drops significantly to perhaps 55 PSI when the valve shifts, a blocked or damaged air line should be suspected.

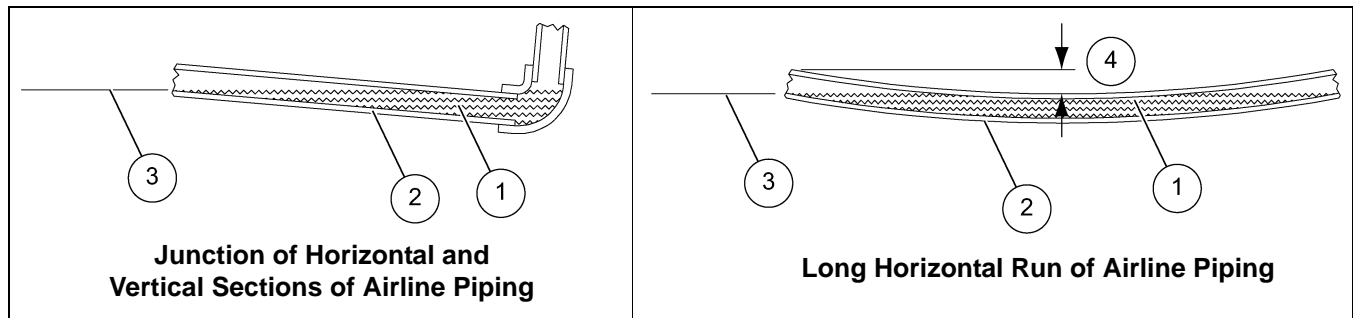

Figure 8A Condensed Moisture Blocking Airline

Ref #	Description
1	Condensed Moisture
2	Airline

Ref #	Description
3	Water Level
4	SAG of Pipe greater than internal diameter

One often overlooked cause of insufficient air flow is moisture condensing and collecting in a low spot in the supply line. [Figure 8A](#) illustrates an exaggerated example of such a problem. It can be seen that if the pipe sags only slightly over a long distance and water collects in the low spot over an extended period of time, the airline could be partially or completely blocked. A similar condition often occurs where there is a junction of horizontal and vertical sections of an air line.

This problem is particularly prevalent when there is high ambient humidity and the equipment operates infrequently and intermittently, as in the case of a sampler.

NOTE: All horizontal runs of an airline should have a moisture trap and the traps should be drained frequently, at least once a day, especially, when humidity levels are high.

Air Components Troubleshooting

Cylinder Leaking

1. External Leakage

- a. Rod seal leakage can generally be traced to worn or damaged seals. Examine the piston rod for wear or damage. Replace the rod and seals if rod's surface is rough or worn out-of-round.
- b. Soft or gummy seals are evidence of incompatibility with some substance in the air supply. Evaluate the area where the air intake is located. If an airline lubricator is included in the system, check to see if the lubricant being used is compatible with the seal material.

2. Internal Leakage

- a. The lipseal piston seals are virtually leak free unless they are worn or damaged. Replace defective seals.
- b. Contaminants in the air supply can lead to scored cylinder walls, resulting in rapid seal wear. If such is the case, check to see if the filter is being drained frequently. A different type of filter may be required, one that can remove finer particles or one that can filter out different kinds of contaminants.
- c. Possible piston cylinder leakage, apparently indicated by piston drift is not always traceable to the piston. A leak through a closed valve port can also cause piston drift.

To determine if a piston is leaking, use a manual override to pressurize one end of the cylinder in question. When the cylinder has completed its stroke but is still pressurized, carefully remove the airline from the other cylinder port that presumably is not pressurized. If air can be detected leaking from the airline connected to the supposedly unpressurized port, then the problem lies elsewhere in the pneumatic system.

8. Troubleshooting

Valve vs. Cylinder Leak Test

When there is continuous leakage out of a valve exhaust port, proceed as follows to determine if the leak is caused by defective valve seals or by defective cylinder seals.

1. Cylinder retracted as shown [Detail 1](#) in [Figure 8B](#).
 - a. If there is continuous leakage out of Port “5”, the valve seals are defective and must be replaced.
 - b. If there is continuous leakage out of Port “3”, the problem can be with the valve seals or the cylinder seals. To determine which proceed as follows.
 - Disconnect the line between Valve Cylinder Port “2” and the cylinder per [Detail 2](#) in [Figure 8B](#).
 - If leakage continues out of Port “3” and/or Cylinder Port “2”, the valve seals are defective and must be replaced.
 - If there is a leakage out of the line from the cylinder, the cylinder seals are defective and must be replaced.
2. Cylinder extended as shown [Detail 3](#) in [Figure 8B](#).
 - a. If there is continuous leakage out of Port “3”, the valve seals are defective and must be replaced.
 - b. If there is continuous leakage out of Port “5”, the problem can be either the valve seals or the cylinder seals. To determine which proceed as follows:
 - Disconnect the line between Valve Cylinder Port “4” and the cylinder per [Detail 4](#) in [Figure 8B](#).
 - If leakage continues out of Port “5” and/or Cylinder Port “4”, the valve seals are defective and must be replaced.
 - If there is a leakage out of the line from the cylinder, the cylinder seals are defective and must be replaced.

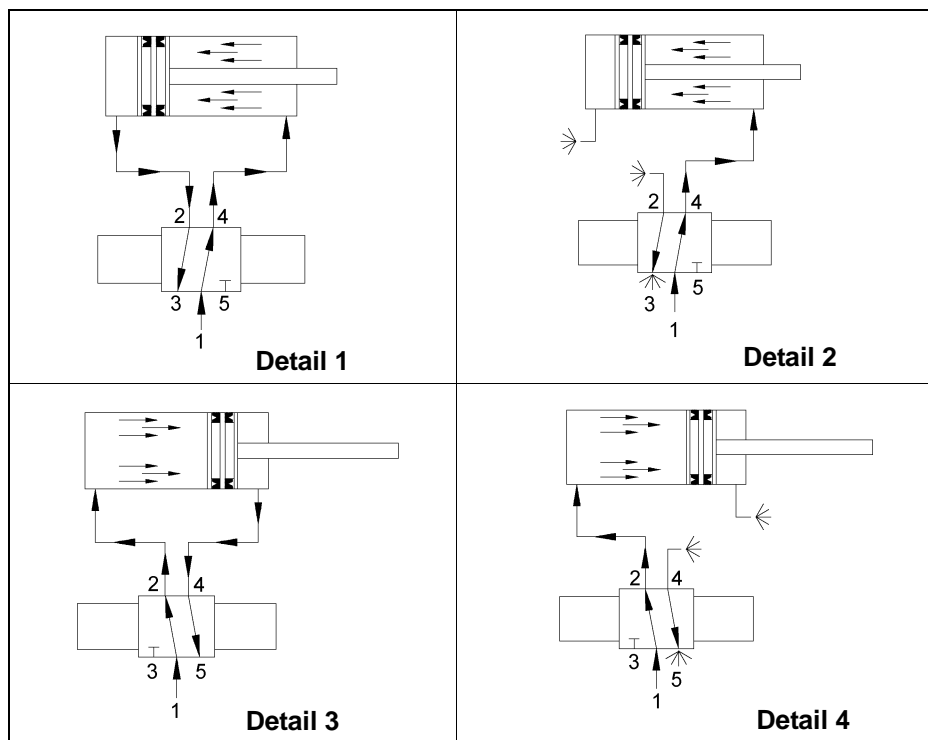
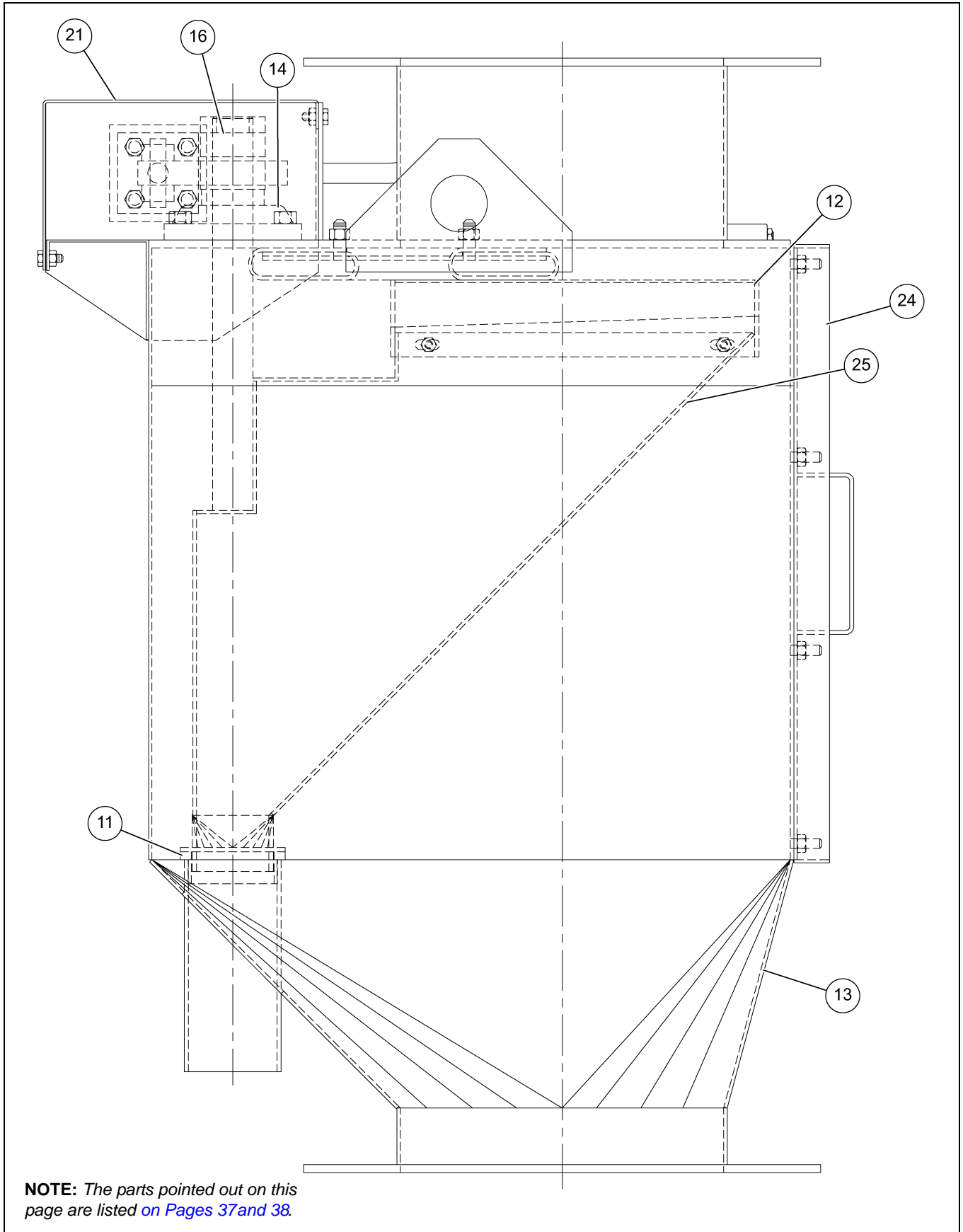
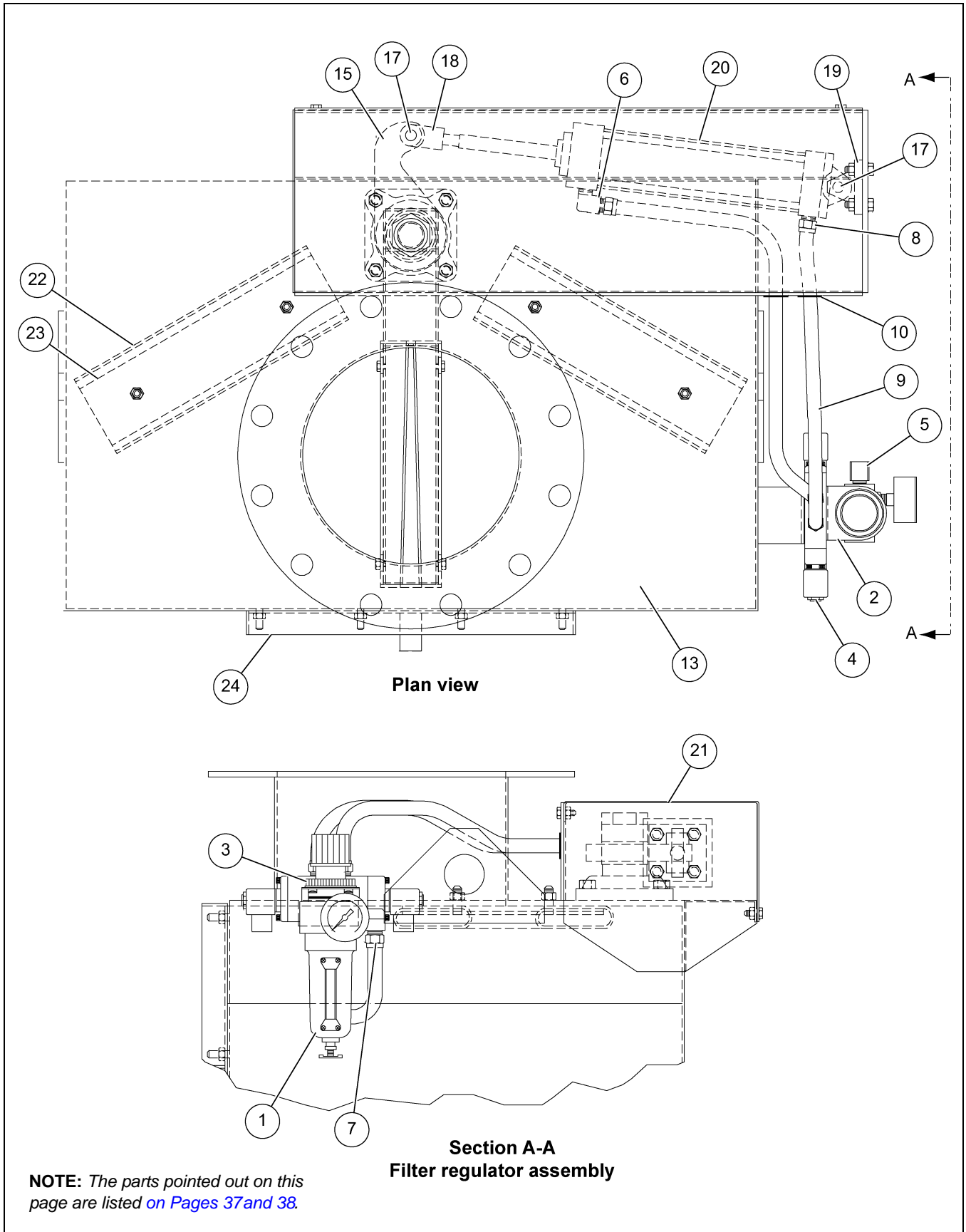

Figure 8B

Sampler Model GRA Parts List



Sampler Model GRA Parts List (Continued)



Sampler Parts Listing GRA Parts List

Ref #	Part #	Description	Qty
1	28163	3/8" NPT Filter Regulator	1
2	28164	Filter Regulator Mounting Bracket	1
3	513735	Mounting Nut for Filter Regulator	1
4****	28167	Standard 4-Way 3/8" NPT Dual Solenoid Valve	1
4****	525660	Explosion-Proof 4-Way 3/8" NPT Dual Solenoid Valve	1
5	34451	Brass 90° Street Elbow 3/8" NPT	1
6	513290	Brass 90° Street Elbow 1/2" NPT	1
7	24553	3/8" Push-Loc to 3/8" MPT STR Adaptor	4
8	24554	3/8" Push-Loc to 1/2" MPT STR Adaptor	2
9	24550	3/8" Push-Loc Hose	A/R
10	34355	Doortite Seal	A/R
11	21000	Nylon GRA Discharge Bearing	1
12	****	Replaceable Cutter Blade	1
13	****	GRA Sampler Housing	1

**** Refer to the certified drawings.

Ref #	GRA-6	GRA-10	GRA-14	Description	Qty
	(Upto 6" Size)	(7"-10" Sizes)	(10"-14" Sizes)		
14	24058	24058	24047	Flange Bearing	1
15	511365	511365	511366	Drive Arm	1
16	511368	511368	511369	Torque Hub	1
17	35869	35869	36465	Pivot Pin	2
18	35868	35868	36640	Rod Clevis	1
19	34544	34544	36429	Eye Bracket	1
20	523830	523830	523831	Air Cylinder	1
21				GRA Drive Cover	1
	511332	511332	511333	Painted Carbon Steel	
	511329	511329	511330	304 Stainless Steel	
22				Dust Seal	
	516793	516794	516795	Urethane Sheet	2
	35073	35073	35073	Gum Rubber Tube	A/R
23				Dust Seal Bracket	2
	511214	511215	511216	HRS (for Urethane)	
	511207	511208	511209	304SS (for Urethane)	
	518359	518360	518361	HRS (for Gum Rubber)	
24				Inspection Cover	1
	511291	511292	511293	Painted Carbon Steel 45	
	511277	511278	511279	304 Stainless Steel 45	
	511298	511299	511300	Painted Carbon Steel 60	
	511284	511285	511286	304 Stainless Steel 60	
25				Sample Pelican	1
	511263	511264	511265	Painted Carbon Steel 45	
	511249	511250	511251	304 Stainless Steel 45	
	511270	511271	511272	Painted Carbon Steel 60	
	511256	511257	511258	304 Stainless Steel 60	

9. Parts List

Ref #	GRA-18	GRA-22	GRA-26	Description	Qty
	(15"-18" Sizes)	(19"-22" Sizes)	(19"-22" Sizes)		
14	24047	301375	301375	Flange Bearing	1
15	511366	524416	524416	Drive Arm	1
16	511369	511370	511370	Torque Hub	1
17	36465	36465	36465	Pivot Pin	2
18	36640	36640	36640	Rod Clevis	1
19	36429	36429	36429	Eye Bracket	1
20	523831	524415	524415	Air Cylinder	1
21				GRA Drive Cover	1
	511333	525174	525174	Painted Carbon Steel	
	511330	525175	525175	304 Stainless Steel	
22				Dust Seal	
	516796	516797	523092	Urethane Sheet	2
	35073	35073	35073	Gum Rubber Tube	A/R
23				Dust Seal Bracket	2
	511217	511218	511219	HRS (for Urethane)	
	511210	511211	511212	304SS (for Urethane)	
	518362	518363	522831	HRS (for Gum Rubber)	
24				Inspection Cover	1
	511294	511295	511296	Painted Carbon Steel 45	
	511280	511281	511282	304 Stainless Steel 45	
	511301	511302	511303	Painted Carbon Steel 60	
	511287	511288	511289	304 Stainless Steel 60	
25				Sample Pelican	1
	511266	511267	511268	Painted Carbon Steel 45	
	511252	511253	511254	304 Stainless Steel 45	
	511273	511274	511275	Painted Carbon Steel 60	
	511259	511260	511261	304 Stainless Steel 60	

InterSystems, Inc. reserves the right to make changes in design or in construction of equipment and components without obligation to incorporate such changes in equipment and components previously ordered.

WARRANTY, LIMITATION OF LIABILITY, DISCLAIMER OF IMPLIED WARRANTIES: InterSystems, Inc. manufactured equipment and components are guaranteed against defects in workmanship or materials for one year from date of shipment. The obligation of InterSystems, Inc. with respect to any goods is limited to replacement or repair of defective parts and equipment provided those parts are returned, shipping costs prepaid, to InterSystems' factory and provided the product has not been subject to misuse, negligence, or accident, or repaired or altered outside of our factory, or other than by an Authorized Service Representative. This warranty does not cover the replacement of parts inoperative because of wear occasioned by use, the cost of replacing parts by a person other than an InterSystems employee or an Authorized Service Representative, or the adjustment of a product where the product was improperly adjusted by the purchaser. In addition, this warranty does not cover components manufactured by others such as motors, drives, clutches, cylinders, valves, blowers, and the like. On those components the standard Manufacturers' warranty applies. In any event, liability is limited to the purchase price paid, and InterSystems, Inc. will, under no circumstances, be responsible for special or consequential damages, or for incidental damages.

INTERSYSTEMS, INC. NEITHER MAKES NOR AUTHORIZES ANY WARRANTY OTHER THAN AS HEREIN CONTAINED. THIS WARRANTY IS IN LIEU OF ALL OTHER WARRANTIES, EXPRESS OR IMPLIED, INCLUDING THOSE OF MERCHANTABILITY AND FITNESS FOR A PARTICULAR PURPOSE.

This equipment shall be installed in accordance with the current installation codes and applicable regulations, which should be carefully followed in all cases. Authorities having jurisdiction should be consulted before installations are made.



InterSystems
9575 N. 109th Ave.
Omaha, Nebraska 68142
Toll Free: (800) 228-1483
www.gsiag.com



InterSystems is a part of GSI, a worldwide brand of AGCO Corporation.