

# Sampler

**Model: PT**

Installation and Operation Manual

PNEG-2193

Version: 1.0

Date: 03-09-18



---

**All information, illustrations, photos, and specifications in this manual are based on the latest information available at the time of publication. The right is reserved to make changes at any time without notice.**

## Contents

<b>Chapter 1 Introduction</b> .....	<b>4</b>
General Safety Statements .....	4
Scope .....	4
Ordering Parts .....	5
Replacement Parts .....	5
Repair Kits .....	5
<b>Chapter 2 Safety</b> .....	<b>6</b>
Safety Guidelines .....	6
Cautionary Symbol Definitions .....	7
Safety Cautions .....	8
Safety Sign-Off Sheet .....	11
<b>Chapter 3 Decals</b> .....	<b>12</b>
<b>Chapter 4 General Information</b> .....	<b>15</b>
System Description .....	15
Optional Features .....	16
Material Sampled .....	16
Sampler Construction .....	16
<b>Chapter 5 Installation</b> .....	<b>17</b>
Receiving Inspection .....	17
Pre-Installation Preparation .....	17
Location .....	17
General Mounting Guidelines .....	17
Material Sample Transport Lines .....	19
Controller Location .....	20
System Wiring .....	20
System Piping .....	21
<b>Chapter 6 Operation and Adjustments</b> .....	<b>22</b>
Control Components and their Functions .....	22
Pneumatic Components .....	25
<b>Chapter 7 Maintenance and Repair</b> .....	<b>28</b>
General Maintenance .....	28
Periodic Inspection .....	28
Lubrication .....	28
Draining and Servicing the Filter .....	29
Mechanical Repair Procedures .....	29
<b>Chapter 8 Troubleshooting</b> .....	<b>32</b>
General PT Sampler Troubleshooting .....	32
Directional Solenoid Valve Troubleshooting .....	33
Air Components Troubleshooting .....	34
<b>Chapter 9 Optional Purge Configurations</b> .....	<b>36</b>
<b>Chapter 10 Parts List</b> .....	<b>38</b>
PT Sampler 5-1/2" Stroke Vertical Flow Side Section View (524075) .....	38
PT Sampler 5-1/2" Stroke Horizontal Flow Side Section View (524076) .....	39
<b>Chapter 11 Warranty</b> .....	<b>41</b>

## 1. Introduction

This manual covers the installation and operation for the Sampler Model PT. This manual provides guidelines for installing the product. You must retain a qualified contractor to provide on-site expertise. INTERSYSTEMS IS NOT RESPONSIBLE FOR THE INSTALLATION OF THIS PRODUCT.

InterSystems reserves the right to improve its product whenever possible and practical to do so. We reserve the right to change, improve and modify products at any time without obligation to make changes, improvements and modifications on equipment sold previously.

### General Safety Statements

1. The Sampler system is designed and manufactured with operator safety in mind. However, residual hazards remain due to the nature of material handling, and specific material hazards. Use extreme caution at all times.
2. Modifications to equipment may cause extremely dangerous situations that could result in damage to the equipment as well as serious injury or death. Never modify the equipment.
3. InterSystems recommends that you contact the local power company to have a representative survey the installation to ensure wiring is compatible with their system and adequate power is supplied to the unit.
4. Consult InterSystems before making any changes to the sampler or its operating environment. Careless changes could result in death or serious injury to people and reduce the performance and service life of the equipment.
5. Never perform any service on this equipment or any other powered equipment until all power has been shut off and locked out so that it cannot be restored without the consent and knowledge of the person who interrupted power. Power includes electrical, fluid, mechanical or pneumatic energy.
6. Never perform any service on this equipment without utilizing the required PPE (Personal Protective Equipment). Refer to the MSDS (s) (Material Safety Data Sheet (s)), on all products to which this equipment is in contact to determine what PPE is required.



***This equipment is to be operated only on the voltage designated on the certified electrical drawings. Fire or explosion may result, which can cause death, serious injury and extensive damage to equipment. Do not connect to voltages other than designated.***



***Compressed air can cause severe injury. Shut off and lock out compressed air source to the sampler and bleed off any and all present compressed air within the sampler pneumatics before attempting any service on this sampler.***

### Scope

The certified drawings list the non-standard components that have been incorporated into the equipment. InterSystems, Inc. normally stocks non-fabricated parts and non-custom OEM parts. Replacement parts for any other components, including fabricated parts and custom OEM components can be supplied upon request.

## Ordering Parts

Direct parts orders or requests for technical assistance to your sales representative or to:

**InterSystems, Inc.**  
 9575 N. 109<sup>th</sup> Ave  
 Omaha, NE. 68137  
 Phone: (402) 330-1500  
 FAX: (402) 330-3350

Please have available the MODEL NUMBER, SERIAL NUMBER and CUSTOMER ORDER NUMBER of the equipment in question as well as the location where the sampler is INSTALLED.

## Replacement Parts

The InterSystems, Inc. sampler is a quality built piece of machinery. As with any machine, parts do wear out and fail. It is InterSystem's recommendation that a small supply of spare parts be kept on hand to cover any minor breakdowns. A separate priced Spare Parts List will be sent identifying the suggested spare parts. It is also necessary to check the certified drawings, which will list any special or custom components utilized on this equipment.

## Repair Kits

The following chart lists repair kits and parts that are available from InterSystems. These kits are offered as a more economical solution by rebuilding the defective part rather than replacing it. However in some cases the part may be beyond repair and replacement will be necessary.

Product Code	Description
512762	Standard Spool Kit for 4-way Directional Valves (ISI 375 Series)
28166	Standard 120 VAC Valve Coil and Housing (ISI 375 Series)
515835	Optional 240 VAC Valve Coil and Housing (ISI 375 Series)
519287	Optional 120 VAC Explosion-Proof Coil and Housing (ISI 375 Series)
516750	Seal Kit for 2" Bore 5/8" Rod Air Cylinder (Sheffer AA Series)
513963	Gauge for Filter Regulator
524011	Filter Element for Filter Regulator (Norgren B08 Series)

### Safety Guidelines

Safety guidelines are general-to-specific safety rules that must be followed at all times. This manual is written to help you understand safe operating procedures and problems that can be encountered by the operator and other personnel when using this equipment. Save these safety guidelines for future reference.

As owner or operator, you are responsible for understanding the requirements, hazards, and precautions that exist and to inform others as required. Unqualified persons must stay out of the work area at all times.

Alterations must not be made to the equipment. Alterations can produce dangerous situations resulting in **SERIOUS INJURY** or **DEATH**.

This equipment must be installed in accordance with the current installation codes and applicable regulations, which must be carefully followed in all cases. Authorities having jurisdiction must be consulted before installations are made.

When necessary, you must consider the installation location relative to electrical, fuel and water utilities.

Personnel operating or working around equipment must read this manual. This manual must be delivered with equipment to its owner. Failure to read this manual and its safety instructions is a misuse of the equipment.

**ST-0001-3**

## Cautionary Symbol Definitions

Cautionary symbols appear in this manual and on product decals. The symbols alert the user of potential safety hazards, prohibited activities and mandatory actions. To help you recognize this information, we use the symbols that are defined below.



This symbol indicates an imminently hazardous situation which, if not avoided, **will result in serious injury or death.**



This symbol indicates a potentially hazardous situation which, if not avoided, **can result in serious injury or death.**



This symbol indicates a potentially hazardous situation which, if not avoided, **can result in minor or moderate injury.**



This symbol is used to address practices not related to personal injury.



This symbol indicates a general hazard.



This symbol indicates a prohibited activity.

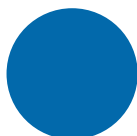

This symbol indicates a mandatory action.

ST-0005-2

### Safety Cautions

#### Use Personal Protective Equipment

- Use appropriate personal protective equipment:

**Eye Protection**



**Respiratory Protection**



**Foot Protection**



**Hearing Protection**



**Head Protection**



**Fall Protection**



**Hand Protection**



- Wear clothing appropriate to the job.
- Remove all jewelry.
- Tie long hair up and back.

ST-0004-1

#### Follow Safety Instructions

- Carefully read all safety messages in this manual and safety signs on your machine. Keep signs in good condition. Replace missing or damaged safety signs. Be sure new equipment components and repair parts include the current safety signs. Replacement safety signs are available from the manufacturer.
- Learn how to operate the machine and how to use controls properly. Do not let anyone operate without instruction.
- If you do not understand any part of this manual or need assistance, contact your dealer.



ST-0002-1



### Maintain Equipment and Work Area

- Understand service procedures before doing work. Keep area clean and dry.
- Never service equipment while it is operating. Keep hands, feet, and clothing away from moving parts.
- Keep your equipment in proper working condition. Replace worn or broken parts immediately.



ST-0003-1

### Stay Clear of Hoisted Equipment

- Always use proper lifting or hoisting equipment when assembling or disassembling equipment.
- Do not walk or stand under hoisted equipment.
- Always use sturdy and stable supports when needed for installation. Not following these safety precautions creates the risk of falling equipment, which could crush personnel and cause serious injury or death.



ST-0047-1

### Sharp Edge Hazard

- This product has sharp edges, which can cause serious injury.
- To avoid injury, handle sharp edges with caution and always use proper protective clothing and equipment.



ST-0036-2

### Install and Operate Electrical Equipment Properly

- Electrical controls must be installed by a qualified electrician and must meet the standards set by applicable local codes (National Electrical Code for the US, Canadian Electric Code, or EN60204 along with applicable European Directives for Europe).
- Lock-out power source before making adjustments, cleaning, or maintaining equipment.
- Make sure all equipment and bins are properly grounded.



ST-0075-1

## 2. Safety

### Stay Clear of Moving Parts

- Stay clear - machine can start without warning.
- Entanglement in gate will cause serious injury.
- Keep all shields and covers in place at all times.
- Lock-out power source before making adjustments, cleaning, or maintaining equipment.



ST-0070-1

### Flying Material Hazard

- Flying material can cause severe eye injury or blindness.
- Wear safety glasses around operating equipment.



ST-0074-1

### Stay Clear of Rotating Parts

- Do not service equipment while it is in operation.
- Entanglement in rotating parts or exposed belts will cause serious injury or death.
- Keep all shields and covers in place at all times.
- Lock-out power source before making adjustments, cleaning, or maintaining equipment.



ST-0072-1



### 3. Decals



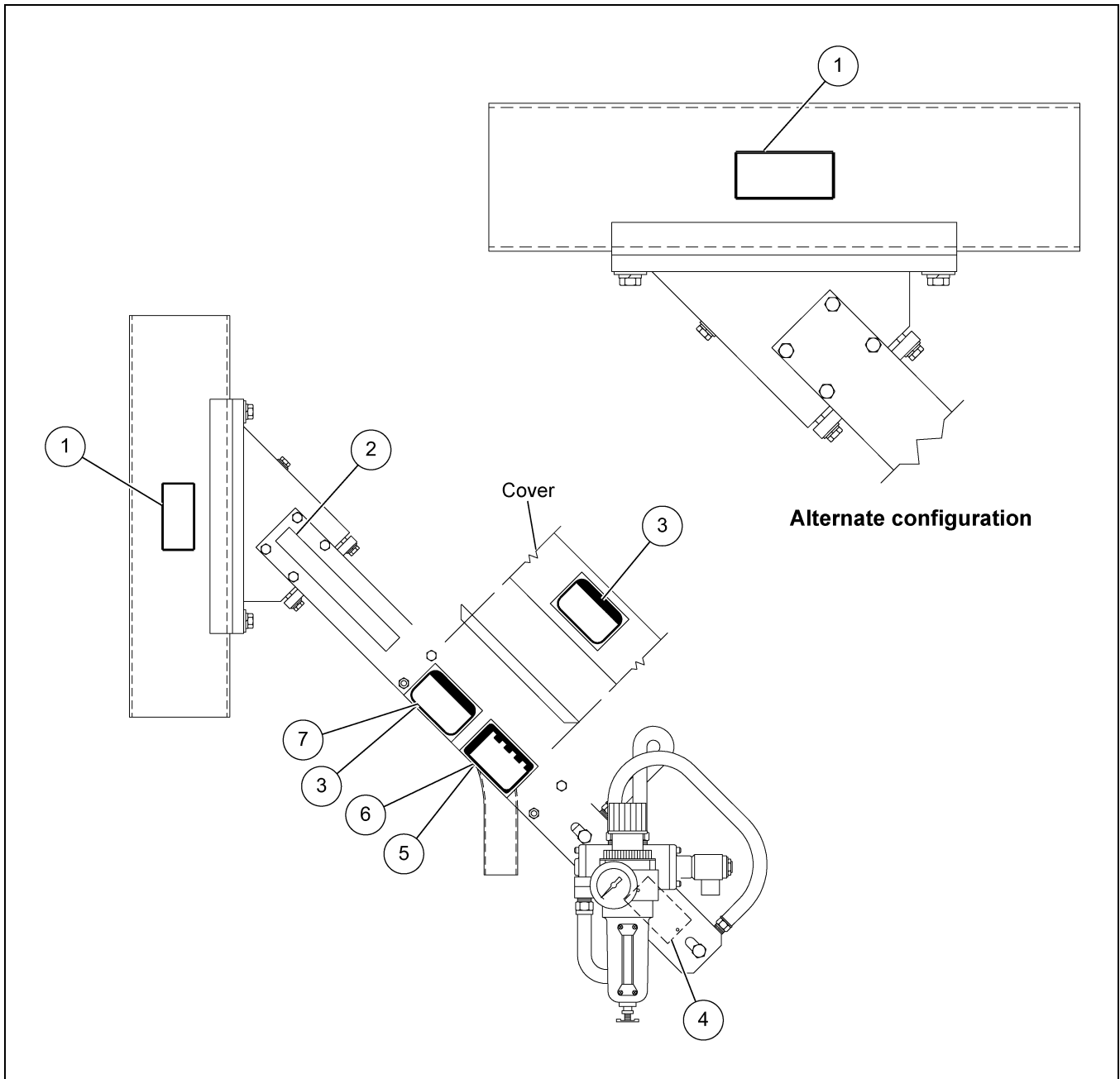

The safety decals on your equipment are safety indicators which must be carefully read and understood by all personnel involved in the installation, operation, service and maintenance of the equipment. To replace a damaged or missing decal, contact us to receive a free replacement.

**InterSystems**  
9575 N. 109<sup>th</sup> Ave.  
Omaha, Nebraska 68137  
Phone: (402) 330-1500  
FAX: (402) 330-3350



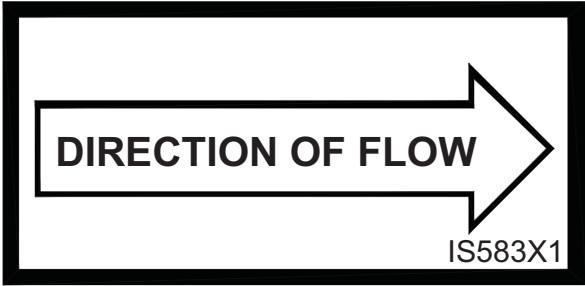

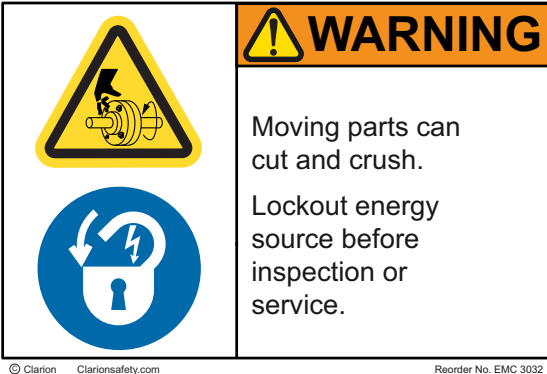
**Figure 3A** Model PT Sampler Safety Label Locations

**NOTE:** These signs must never be removed, tampered with, painted over or obscured in anyway. If labels are damaged or become unreadable, replacement labels are available from InterSystems.

Ref #	Decal #	Decals	Description
1	IS583X1		<p>Direction of Flow</p> <p><b>NOTE:</b> Arrow on label aligned to match material flow direction as noted on assembly drawing of sampler.</p>
2	IS517X1		IS Samplers
3	EMC 30 32		Moving Part
4	IS Tag		IS Serial No Tag

### 3. Decals

Ref #	Decal #	Decals	Description
5	EMC 36 34		Eye Protection Air Blast
6	EMC 40 232		Lock Out Machine
7.	EMC 40 332		Starts Without Warning

## System Description

The PT Sampler is designed to collect a representative sample of granular, flake, pellet, or other materials in a gravity or pressurized conveying line or from a hopper tank or pressure vessel. [Figure 4A](#) illustrates a typical PT Sampler application.

Sample collection is initiated in response to either an operator's manual command or a signal automatically generated by controller logic, usually time-based but which could also be volume or quantity based. A sample cycle begins when a double-acting pneumatic cylinder forces the slotted sampling tube (probe) into the product line to collect a sample of the material. The sample flows through the sample tube and out the discharge for as long as the sample slot is in the material conveying line. Next, the sample tube probe is withdrawn into the seal housing isolating the sample and sample tube cavity from the conveying line. The remaining sample in the sample tube then falls down and out the 1-1/2" (38 mm) O.D. discharge tube to the desired sample collection point, at which point an InterSystems SCS Sample Collection System (optional) may be installed.

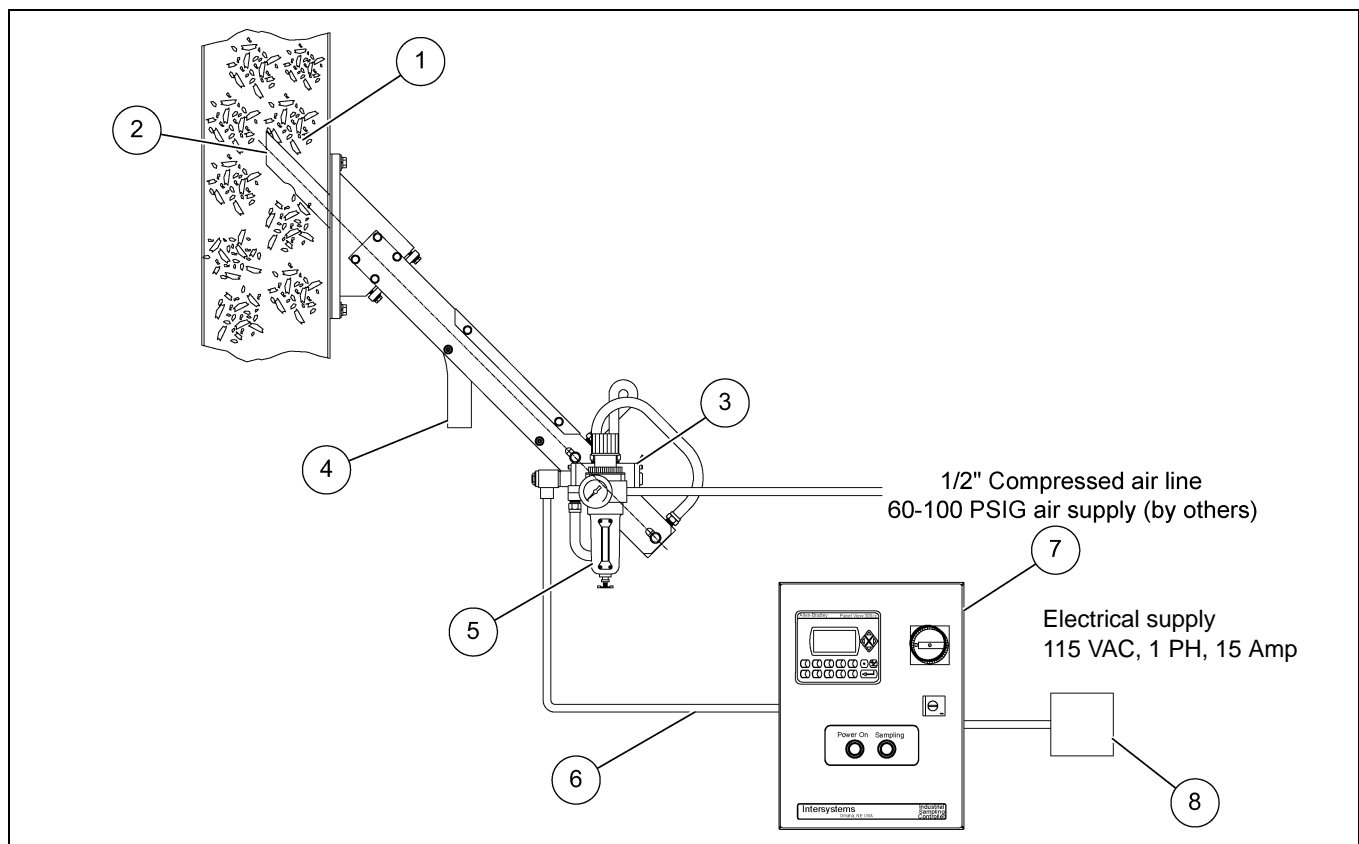

**Figure 4A** Typical Installation, Model PT Sampling System

Ref #	Description
1	Material to be Sampled
2	Sample Probe
3	Solenoid Valve
4	Sample Discharge

Ref #	Description
5	Filter/Regulator
6	Electrical Conduits
7	Sampler Control Panel
8	Circuit Breaker

## 4. General Information

---

### Optional Features

The certified drawings indicate which, if any, optional features are included with a sampling system. Some of the more frequently specified optional features are briefly described in the following list.

1. Controller arranged to initiate a sampling cycle based on quantity or volume of material passing through conveying line rather than upon elapsed time periods.
2. Explosion-Proof Sampling System. There are several major differences in an explosion-proof sampler as compared to a standard sampling system. An explosion-proof sampler will typically have the following features.
  - a. An explosion-proof solenoid on the directional control valve with the rating of:
    - Class 1, Groups C and D, Division 1 and 2
    - Class 2, Groups E, F and G, Division 1 and 2

The explosion-proof sampler control is available in two enclosure classifications:

- a. The NEMA 9 control with the rating of:
    - Class 2, Groups E, F and G, Division 1 and 2
  - b. The NEMA 7 control with the rating of:
    - Class 1, Groups C and D, Division 1 and 2
    - Class 2, Groups E, F and G, Division 1 and 2
3. Purge air systems to either aid in material discharging from the sampler or to prevent material from building up in V-ring packing seals.
  4. Components of special materials, such as 316 stainless steel, monel, inconel or nedox coatings.
  5. Programmable controls to sequence the sampler and the sample collection equipment.

### Material Sampled

Most materials from light to heavy density granules, flakes and pellets.

### Sampler Construction

Standard sampler housing construction is of painted cast aluminum. The sample probe is of Type 304 Stainless Steel. Other materials and/or finishes appropriate to the operating environment and the material or product being sampled may be used. Refer to the certified drawing(s) for any optional or special components installed on the sampler.



## Receiving Inspection

Carefully inspect the sampling system for damage as soon as it is received. Also, verify that the quantity of parts or packages actually received corresponds to the quantity shown on the packing slip. Report any damage or shortage to the delivering carrier as soon as possible. InterSystems responsibility for the equipment ended with acceptance by the delivering carrier. Refer to the bill of lading.

## Pre-Installation Preparation

**NOTE:** *Before starting sampling system installation, study this manual, the certified drawing(s) furnished with the system, and other applicable documents (including, but not limited to OSHA regulations; the National Electrical Code; and all other applicable federal, state, and local codes and regulations).*

## Location

The PT sampler is typically mounted onto a vertical or horizontal conveying line carrying the product to be sampled as shown in [Figure 4A on Page 15](#). The sampler axis is installed at a 45° angle to the axis of the product line. Additionally, the sampler should be located where the product has a non-turbulent flow pattern. The sampler and associated equipment should be located for ease of access and maintenance.

The sampler is to be installed only as shown on the certified drawing(s). If an alternate mounting arrangement is desired contact InterSystems prior to installation for proper guidance. The sampler is of a general design with modifications specifically for your application. It may be necessary to rework the sampler in order for it to function properly if you alter the application.

## General Mounting Guidelines



**Sampler cannot support any other equipment or conveying line. Collapse of the whole system can cause death, serious injury, and extensive damage to equipment. Properly support all spouts, containers, and conveying lines.**

**NOTE:** *If the surface area to which the mounting plate is to be attached is warped or bent, straighten and smooth the metal so the sampler will be properly aligned when the installation is complete. The surface to which the sampler is mounted must not flex. The sampler cylinder must be rigidly supported; any flexing will damage the sampler.*

**NOTE:** *Over tightening the mounting fasteners will warp or crack the seal housing flange. Improper sampling will result.*

## 5. Installation

### Sampler Without Optional Mounting Accessories

1. Locate and mark the desired mounting location on the product line.
2. Cut and deburr a 2-1/2" diameter hole in the product line through which the sample tube will pass to collect material samples.
3. The mounting flange on the end of the seal housing has four 0.406" (13/32") clearance holes for 3/8" mounting screws or studs. Using the sampler mounting face as a pattern, layout or transfer punch the hole locations onto the conveying line.
4. Drill and tap the holes for the mounting screws, or weld studs to the conveying line for fastening the sampler.
5. Ensure that the O-ring is seated in the groove on the sampler housing mounting flange and verify that the sample tube extends and retracts without interference.
6. Install the sampler on the mount surface and tighten the mounting fasteners to ensure proper sealing between the sampler seal housing and the product line.
7. If the conveying line is a pressure or vacuum line, check to see that the seal at the connection is airtight. Re-tighten fasteners if necessary.

### Factory Pre-Mounted Sampler

As furnished, the pre-mounted sampler is already firmly attached to a length of tube, pipe, etc.

1. Remove a section of pipe or chutework where the sampler is to be installed.
2. Locate the sampler pre-mount in the desired position.
3. Attach the sampler pre-mount using one of the following methods.
  - a. Weld the sampler pre-mount ends directly to the existing pipe or chutework.
  - b. Clamp the sampler pre-mount ends to the existing pipe utilizing compression couplings.
  - c. Weld matching flanges to the existing pipe or chutework and sampler pre-mount.
4. If the conveying line is a pressure or vacuum line, check to see that the seals at the connections are airtight. Re-tighten fasteners and/or re-weld if necessary.

### Field-Mounted Sampler Using Weld-On Plate

Weld-on plates are typically used when Mounting the sampler to a large existing surface, such as on a storage hopper or a long section of chutework.

1. Locate and mark the desired mounting location on the conveying line.
2. Cut and deburr a 2-1/2" diameter hole in the conveying line through which the sample tube will pass to collect material samples.
3. Position the sampler mounting plate by aligning the 2-1/2" diameter sample probe clearance holes.
4. Tack weld the sides of the mounting plate to the product line surface and double check alignment.
5. Weld a continuous bead around all sides of the mounting plate.

**NOTE:** *When welding the mounting plate to thin gauge sheet or thin plate, skip weld alternating sides of the mounting plate to limit heat input to minimize warping.*

6. Ensure that the O-ring is seated in the groove on the sampler housing mounting flange and verify that the sample tube extends and retracts without interference.
7. Install the sampler on the mount surface and tighten the mounting fasteners to ensure proper sealing between the sampler seal housing and the product line.
8. If the conveying line is a pressure or vacuum line, check to see that the seal at the connections are airtight. Re-tighten fasteners and/or re-weld if necessary. If the weld leaks, remove the sampler and O-ring before making any repair welds. Weld heat will damage or destroy the gasket and the Teflon seals in the seal housing.

### Field-Mounted Sampler Using Clamp-Type Mounting Brackets

Clamp-type mounting brackets are used on round tube or pipe conveying lines.

1. Locate and mark the desired mounting location on the conveying line.
2. Cut and deburr a 3-1/2" diameter hole in the product line through which the sample tube will pass to collect material samples.
3. Make sure the 1/8" thick Neoprene gasket is in place inside the clamp adapter.
4. Position the clamp bracket by aligning the sample probe clearance holes and tighten the clamp fasteners.

**NOTE:** *Over tightening the bracket fasteners will distort the conveying line tube or pipe. The tube can crack or buckle, the sampler will not be properly aligned with the product stream, and in cases where the conveying line I.D. is nearly the same as the stroke of the sampler, the sample tube may actually strike the opposite side of the tube as it extends.*

5. Ensure that the O-ring is seated in the groove on the sampler housing mounting flange and verify that the sample tube extends and retracts without interference.
6. Install the sampler on the mount surface and tighten the mounting fasteners to ensure proper sealing between the sampler seal housing and the product line.
7. If the conveying line is a pressure or vacuum line, check to see that the seal at the mounting clamp is airtight. Tighten clamp fasteners if necessary.

### Material Sample Transport Lines

The tubing used to transport material samples must be compatible with the operating environment and the material sampled. Typically a 1-1/2" I.D. flexible hose is slipped over the discharge tube and held in place by a worm clamp. The hose is then routed to allow material to flow via gravity to a convenient collection point. At that point the hose may be connected to a collection jar bracket or a Sample Collection System cabinet.

If rigid tubing is desired for the sample transport line a short length (5' minimum) of flexible hose will still be needed to connect the sample line to the discharge of the sampler that will permit movement of the sample discharge (sample probe). The discharge outlet on the sampler is actually the exposed end of the moving sample probe.

Make all connections airtight and make sure all interior surfaces of joints are smooth and flush. Any ragged or raised tube ends will collect dust and debris as well as retard material flow. Air leaks can interfere with the pressure or vacuum conveying and sampling system. Escaping sample material can contaminate surrounding atmosphere and equipment.

## 5. Installation

---

### Controller Location

1. Use vibration isolation pads when mounting the control enclosure or mount the controller in a vibration-free location.
2. Unless ordered for severe duty, locate controller so it is protected from water and dust.
3. Unless an explosion-proof rated controller was specifically ordered, DO NOT locate the controller in a hazardous area.
4. Most applications require that the sampler be in easy view of the controller.

### System Wiring

Refer to the certified electrical drawing(s) for specific wiring requirements. As explained in Terminal Strip [on Page 23](#), the 19-position barrier terminal strip in the controller enclosure is the connection point for ALL external circuitry.

The controller was completely assembled and tested with the sampler before it left the factory. The electrical installation must comply with OSHA Regulations; the National Electrical Code; and all other applicable federal, state, and local codes and regulations.

If wiring between the controller and the sampler unit is run through rigid conduit, use a short length of flexible conduit to connect wiring to the sampler. This will isolate the rigid conduit from any vibration originating in the product conveying line and sampler.

### Electrical Power Requirements, System

110/120 VAC 50/60 Hz, Single Phase, 10 Amp Service

Optional - 220/240 VAC 50/60 Hz, Single Phase, 5 Amp Service

Refer to the certified electrical drawing(s) for specific wiring requirements. InterSystems strongly recommends that electrical service to the sampling system be an isolated line. Voltage fluctuations and line noise can affect the controller's circuit board, thus causing the sampler to malfunction.

### Controller

110/120 VAC, 50/60 Hz, Single Phase, 2 Amp Max

Optional - 220/240 VAC, 50/60 Hz, Single Phase, 1 Amp Max

### Solenoid Valve Coil

110/120 VAC, 50/60 Hz, Single Phase, 7 Watts

Optional - 220/240 VAC, 50/60 Hz, Single Phase, 7 Watts

## System Piping

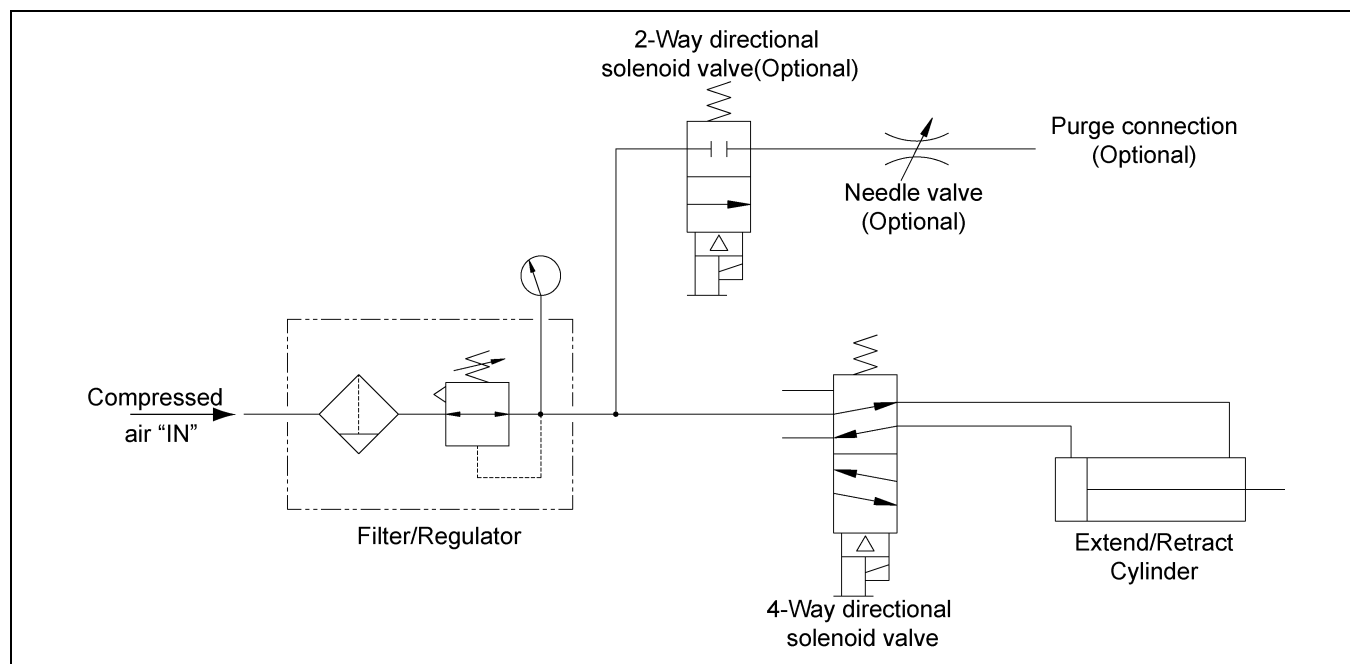

**Figure 5A** Pneumatic Schematic

**NOTE:** Use only cleaned, pickled, descaled, and oiled pipe for air supply lines. dirt, scale, and debris usually found in standard pipe quickly clogs filter regulators, valves, etc. Use only Teflon tape to seal pipe joints. Carefully apply the tape to pipe and fittings so no fragments enter the system.

The pneumatic system was pre-plumbed and tested with the sampler before it left the factory. The final installation must comply with OSHA Regulations and all other applicable federal, state, and local codes and regulations.

As shown on the certified drawing(s), the solenoid valves and filter/regulator (F/R) were mounted on the sampler at the factory. The user or installer must pipe the compressed air supply to the F/R. Minimum pipe size for the air supply to the filter/regulator is 1/2" NPT, reduced to 3/8" NPT at sampler. Larger piping to the sampler, and/or a surge tank located at the sampler, will be required on installations where the compressed air source is further than 200' from the sampler to prevent excessive drop in air pressure.

InterSystems recommends installing a lockable shut off valve upstream of the filter/regulator. The shut off valve facilitates maintenance as it allows the sampler's pneumatic system to be maintained and repaired without shutting down other equipment supplied from the same air source.

## Compressed Air Consumption

A complete sampling cycle requires that the cylinder extend and retract. To determine the compressed air requirements to operate the sampler, multiply the consumption per cycle (a standard PT sampler requires 0.11 SCF @ 80 PSI) by the number of cycles per minute. The number calculated is the SCFM (Standard Cubic Feet per Minute) of air required. A typical cycle takes between 1-15 seconds, depending on the control settings.

The pneumatic system on the sampler, consisting of the filter/regulator, directional control valve and air cylinder was pre-plumbed and tested at the factory. The regulator is factory set at 80 PSI.

The regulator cannot increase downstream outlet pressure above the upstream inlet pressure. If the pressure from the regulator is not sufficient to operate the cylinder, some means must be found to increase the inlet pressure to the regulator. Recommended air supply pressure is 80-100 PSI.

## 6. Operation and Adjustments



*Failure to observe all safety rules, written and implied and those suggested by common sense, can result in death, serious injury and/or equipment damage. Lock out power before performing any maintenance.*

### Control Components and their Functions

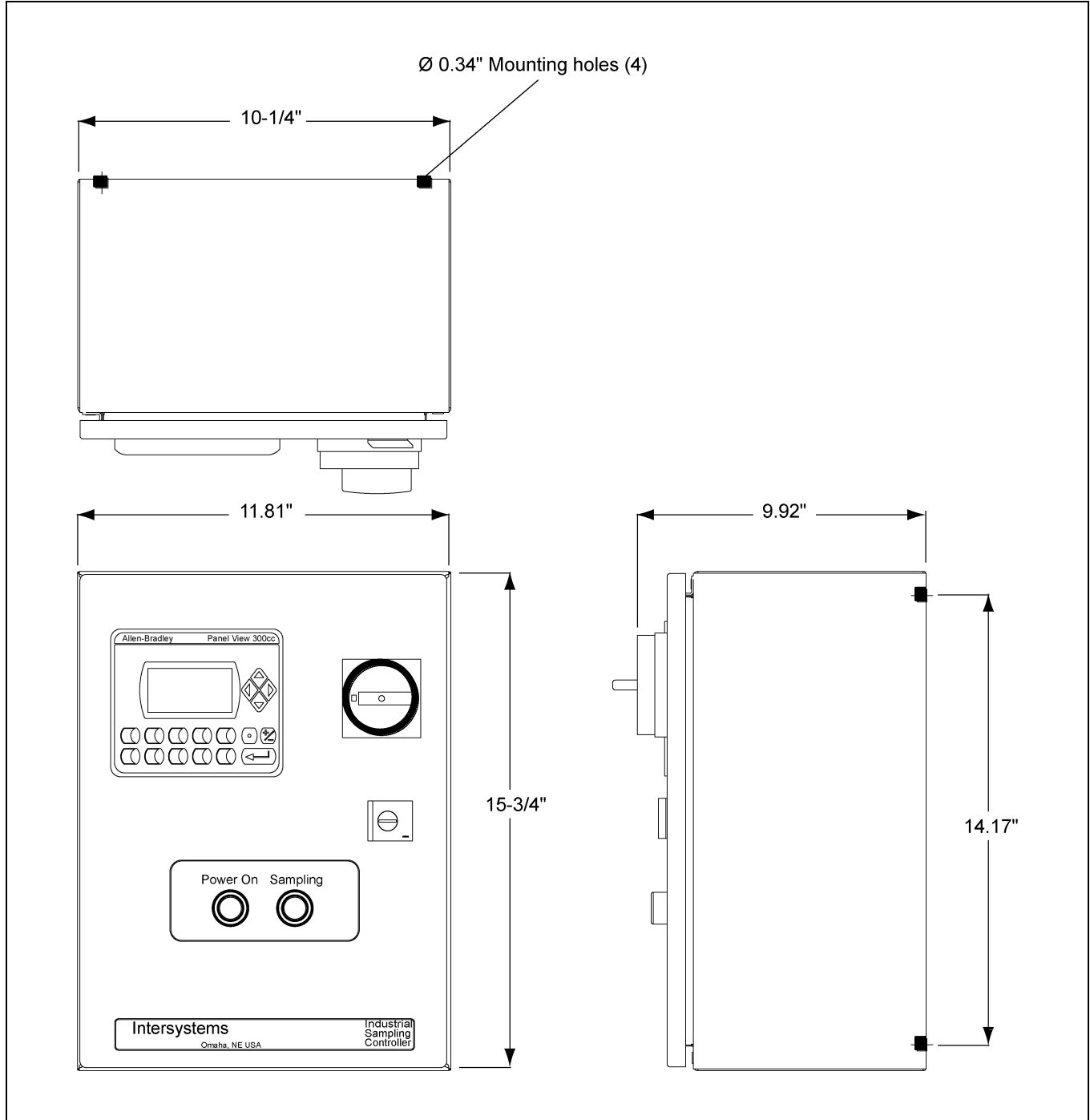

**Figure 6A** Standard NEMA 4 Control Panel Detail

Refer to the certified electrical drawing(s) for dimensions on control panels with optional features.

### Power OFF/ON Switch (S1)

The power OFF/ON Switch controls the electrical power to the controller and the sampler.



*This machine starts without warning. Moving parts can cause severe injury. Clear area prior to controller start-up.*

### Power Pilot Light

This light is illuminated as long as power is available to the controller and the POWER switch (S1) is set to ON.

### Sampling Pilot Light

This light is illuminated when a sampling cycle has been initiated and will stay lit until the sampling cycle has completed.

### Control Keypad

The operator keypad is the source of all inputs necessary to operate the control.

The operator keypad is set up using linked menus to step through the operation of the control.

See the control manual PNEG-2170 for further information on the sampler control.

### Main Fuse (FU1)

The fuse, located along the top center of the control, protects the controller and sampler components against overloads and short circuits.

For 110/120 VAC, 1 PH operation, use ONLY a BUSS Type FNM 2 Amp, 250 VAC Slo-Blo fuse or equivalent.

For 220//240 VAC, 1 PH operation, use ONLY a Buss Type FNM, 1 Amp, 250 VAC Slo-Blo fuse of equivalent.

### Terminal Strip

This 19-position terminal strip is located along the bottom of the controller. It serves as the controller's interface and connection point for all external circuits and for the components mounted inside the enclosure. Refer to the certified electrical drawing(s).

### Power Supply

The controller is equipped with a power supply which converts 120/240 VAC to 24 VDC for the operation of the PLC, Micro-View, display lights, input signals and the operation of the control relays. Refer to the certified drawing(s).

## 6. Operation and Adjustments

---

### Control Relays

The controller is equipped with four control relays which are driven by the PLC 24 VDC outputs.

Each relay has a mechanical flag indicator showing the relay is energized.

The relay contacts are wired for 120/240 VAC. Refer to the certified drawing(s).

### Micrologix PLC

The PLC for the control is an Allen Bradley Micrologix controller. The PLC operates using 24 VDC and is prewired to the proper terminal strip inputs and outputs. The processor program is protected to prevent any alterations to the existing program. This control is designed to run Intersystem equipment.

### Manual Sampling

The operator may choose to run the sampler in Manual Mode by selecting manual mode in the PanelView menu. (Refer to manual PNEG-2170.) After selecting manual mode, each time F1 is pressed on the PanelView, a manual sample is initiated.

### Automatic Sampling

The operator may choose to run the sampler in the Automatic mode by selecting automatic mode in the PanelView menu. (Refer to manual PNEG-2170.) **NOTE:** *A jumper or switch must be installed between the controller's terminals 1 and 2 to initiate automatic sampling. When automatic mode is selected, an automatic sample will not be initiated until the jumper circuit between terminals 1 and 2.* By installing a remote switch across terminals 1 and 2, the user can initiate the sampling cycle remotely. See manual PNEG-2170 for sampling automatic sampling options.



## Pneumatic Components

### Solenoid Valves V-1

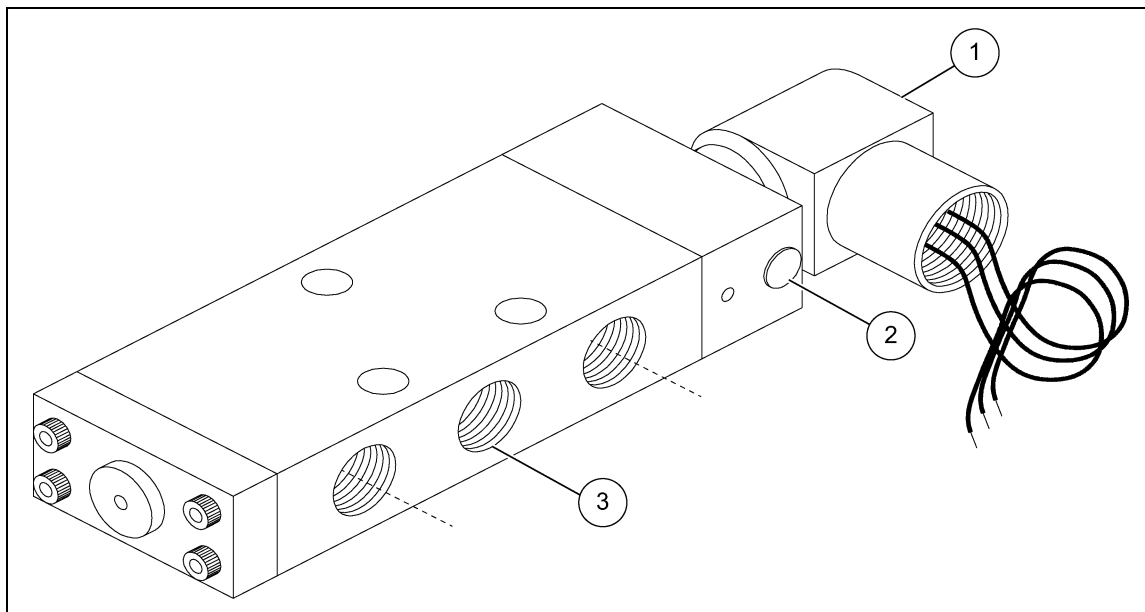

Figure 6B Solenoid Valve

Ref #	Description
1	Solenoid
2	Manual Over-Ride
3	Air Supply Port

This valve is a 4-way, 2 position, spring return, single solenoid operated control valve. This valve controls the air cylinder, alternately pressurizing the cap end and rod end of the cylinder to extend and retract the sample tube.

When the valve's solenoid is energized, the internal valve spool shifts, pressurizing the cap end of the cylinder. The cylinder extends, pushing the sample probe into the product stream. When the solenoid is de-energized, the valve spring forces the valve spool to shift again, pressurizing the rod end of the cylinder. The cylinder retracts, pulling the sample probe from the product stream.

The valve has a manual over-ride button that allows the operator to cycle the sampler air cylinder without the aid of the controller. By pushing the manual over-ride button, the internal valve spool is positioned manually and the sampler air cylinder will extend and remain there until the button is released. When the over-ride button is released, the cylinder will return to its home position.

## 6. Operation and Adjustments

### Needle Valve (Optional)

This valve regulates the air flow feeding the purge option. This valve will require some adjustment upon initial sampler start-up. [Figure 9A on Page 36](#) shows the two available purge configurations.

1. The “Sample Purge” type aids in the flow of material out of the sampler and into the sample container. This purge, which is controlled by the sample purge solenoid valve V-2, forces air into the sample probe.
2. The “Lantern Ring Purge” helps keep the material being sampled away from the sampler packing seals. This purge, which only has the needle valve for control, forces air continuously ahead of the probe seals to keep the sampled material from being forced into the seals.

### Sample Purge Solenoid Valve V-2 (Optional)

This valve operates the sample purge option. The valve is a 2-way, normally closed, spring return, single solenoid operated control valve. As shown in [Figure 9A on Page 36](#), it is plumbed in conjunction with the needle valve to correctly control the purge air flow. The purge solenoid is typically wired so that after the sample probe has retracted the purge air is fed into the sample probe thus aiding in the flow of material out of the sampler. Refer to the certified electrical drawing(s) for proper wiring requirements.

### Air Filter/Pressure Regulator

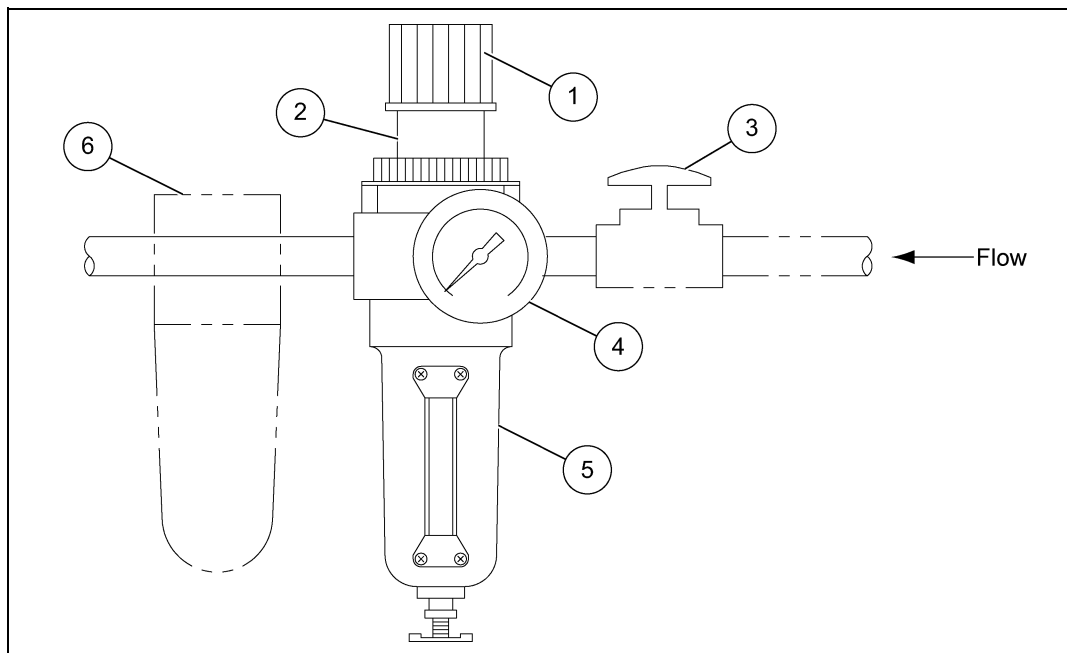

Figure 6C Filter/Regulator

Ref #	Description
1	Adjustment Knob
2	Air Regulator
3	Shut Off Valve (Optional)

Ref #	Description
4	Air Pressure Gauge
5	Air Filter and Bowl with Sight Glass
6	Lubricator (Optional)

The air filter/regulator assembly provides a clean and regulated air supply to the samplers pneumatic components. A pressure gauge gives the operator an accurate reading of the downstream air pressure. The regulator is equipped with an adjustment knob for controlling the outlet pressure and a manual “petcock” type drain for draining the filter bowl.

Prior to introduction of air supply, turn the adjustment knob counterclockwise until all load is removed from the regulating spring. Turn ON system air pressure. Turn adjustment knob clockwise until desired outlet pressure is reached.

To avoid minor re-adjustments after making a change in the pressure setting, always approach the desired setting from a lower pressure. When reducing from a higher setting to a lower setting, first reduce to a pressure setting lower than desired and then adjust upward.

To “lock-in” the pressure setting on the regulator, push the lockring on the adjustment knob down until it snaps into place. To release pull the lockring upward. The pressure setting can be made tamper resistant by installing a seal wire in the groove above the lockring.

### **Pneumatic Cylinder**

This double-acting air cylinder extends and retracts the sample probe. Standard sampler stroke length is 5-1/2". The cylinder rod is connected to the sample probe by means of rod clevis and pin. Solenoid valve V-1 controls extension and retraction of the cylinder.

## 7. Maintenance and Repair



**Failure to observe all safety rules, written and implied and those suggested by common sense, can result in death, serious injury and/or equipment damage. Lock out power before performing any maintenance.**

### General Maintenance

A good maintenance program involves thorough general housekeeping, adequate periodic re-lubrication, and replacement of worn or damaged components.

### Periodic Inspection

At regularly scheduled intervals, while observing all safety precautions, observe the sampler as it operates. Inspect for:

1. Loose or missing hardware
2. Adequate lubricant in lubricator
3. Structural damage
4. Rust or corrosion
5. Damaged wiring, including exposed conductors and connections
6. Damaged airlines or pneumatic components
7. Make sure that all guards are in place and that all warning labels are in place and legible.  
*See Page 7, GENERAL SAFETY INFORMATION, explains the purpose and intended location of the warning signs. Warning signs are an important part of any safety program; replace any missing signs IMMEDIATELY.*

### Lubrication

#### Airline Lubricator

An airline lubricator is not required. The cylinder is of a non-lube design requiring NO lubrication. If the use of a lubricator is desired, it must be field mounted between the filter/regulator and the directional control valve. If a lubricator has been added to the system, the user must determine the appropriate lubricant and the proper intervals for refilling the reservoir. Refer to the lubricator's manufacturers technical literature. Note that by introducing oil into the airline, it will be discharged into the surrounding environment near the air exhausts of the directional control valve(s) on the sampler.

## Draining and Servicing the Filter



**Escape of pressurized air, fluids, and contaminants at high velocity can cause injury to unprotected eyes. Always wear eye protection when draining a filter.**

Drain the accumulated fluid whenever the fluid level in the reservoir (quiet-zone) rises to the lower baffle. Filters have either a screw-type drain or a push-type drain. If the filter requires frequent draining, consider installing an automatic drain or an air drying system. Periodically, the bowl may need to be removed to clean out accumulated moisture and contaminants.

1. Shut off and lock out the air supply.
2. Operate a valve or loosen an airline connection to relieve all pressure downstream from the filter/regulator.
3. Remove and clean the bowl; various types of clamp rings or threaded collars are used to retain bowls.

**NOTE:** *The bowls of filter/regulators can not be removed while pressurized. Internal pressure prevents the clamp ring or threaded collar from turning.*

4. Clean or replace the filter element.
5. If the bowl seal is damaged or brittle replace it. In any event lightly coat the seal with petroleum-based grease to help hold it in position.
6. Re-install the bowl. Turn ON pressure and make sure the bowl is seated and sealed.

## Mechanical Repair Procedures

### Adjustment of Seal Pressure

A series of V-ring packing assemblies and spacers within the seal housing support and seal the sample tube. When the sampler has operated for an extended period of time, the seals may wear or extrude. If evidence of leaking from the conveying line along the sample tube is noticed, first try to increase the compressive force on the seal and spacer stack.

As shown on the section drawings of the samplers [on Pages 38-39](#), the V-ring packing seals are held compressed by the compression plate. Two 1/4"-20 UNC hex head screws clamp the plate to the rear flange of the seal housing. Using a 7/16" wrench evenly tighten the two cap screws a 1/2" turn at a time. This will compress the seal and spacer stack, increasing the seal effect on the sample tube.

**NOTE:** *Excessive compression on the seal and spacer stack will result in permanently deformed and ineffective seals that will have to be replaced. It is possible to over tighten the seal and spacer stack which can result in the seizure of the sample tube, rendering it incapable of extending or retracting.*

If the leak can not be stopped by adjusting seal pressure, then the seals will have to be replaced as explained in Seal Replacement Section [on Page 30](#).

## 7. Maintenance and Repair

### Seal Replacement

When following the instructions below, refer to the applicable drawing of the sampler. Reference the section drawings of the samplers [on Pages 38-39](#) and the certified drawing(s).

1. Shut off and lock out all power (electrical and pneumatic).
2. Shut down the conveying line and remove the sampler assembly. Install a properly designed cover plate over the hole in the conveying line. Save the gasket(s); if any have deteriorated or are damaged, order replacements.
3. In order to remove the seals, remove and retain the following components and save ALL fasteners:
  - a. Remove the eight 1/4"-20 UNC hex head bolts attaching the side rails to the seal housing.
  - b. Remove the two 1/4"-20 UNC hex head compression plate screws.
  - c. Pull the seal housing off of the sample probe.
  - d. Remove the 1/4"-20 UNC bolt(s) over the packing retainer and the purge spacer if applicable.
  - e. Remove the seals and spacers taking care to avoid damaging the seal housing bore. If necessary, use a 2" diameter round plastic bar or wooden dowel to push with.
  - f. Replace worn items and clean the remaining components. Remove any burrs or scratches from the bore of the seal housing.
4. Rebuild the sampler in the following order.
  - a. Refer to the section drawings of the samplers on pages [on Pages 38-39](#), they illustrate the order of insertion and orientation of seals and spacers. Carefully insert the seals and spacers from the rear of the seal housing, pushing them towards the front.
  - b. Re-install the 1/4"-20 UNC bolt(s) over the packing retainer and the purge spacer if applicable.
  - c. Position the compression plate so that it bears on the end of the rear spacer. Loosely re-install the two 1/4"-20 UNC hex head screws which clamp the plate to the seal housing flange.
  - d. Carefully slide the seal housing over the sample tube and into position.
  - e. Re-install the eight 1/4"-20 UNC hex head bolts fastening the side plates to the seal housing. Make certain that the seal housing is aligned with the sample tube so there is no side thrust. Then securely tighten all the screws.
  - f. Evenly tighten the compression plate screws to firmly compress the seal and spacer stack.
5. Remove the cover plate on the sample conveying line and reattach the sampler.
6. Restore power to the sampler. Use the manual over-ride to operate it through several collection cycles. If air leaks along the sample tube are detected, evenly tighten both compression plate screws 1/2" turn. Make sure compression plate flange remains parallel to the seal housing flange. Repeat the process until no air leakage is detected.

### Sample Probe and Seal Replacement

When following the instructions below refer to the applicable drawing of the sampler. Reference the section drawings of the samplers [on Pages 38-39](#) and the certified drawing(s).

1. Follow instructions in Seal Replacement Section [on Page 30](#) “1” through “3”.
2. Disconnect the sample probe from the air cylinder assembly by removing the clevis pin from the rod clevis on the air cylinder.
3. Clean and inspect any items to be reused. Replace if worn or damaged.
4. Re-assemble the sample probe to the air cylinder assembly by re-installing the clevis pin into the rod clevis on the air cylinder.
5. Continue by following instructions in Seal Replacement Section [on Page 30](#) “4” through “6”.

## 8. Troubleshooting

### General PT Sampler Troubleshooting



**Careless or accidental restoration of power can result in death or serious injury. Make certain area is clear before removing lock outs.**

Problem	Possible Cause	Corrective Action
Sampler does not cycle in either Auto or Manual modes (Power light OFF).	Power switch OFF.	Turn power switch ON.
	Circuit breaker is open.	Reset breaker.
	Main fuse is blown (FUI).	Replace. Refer to main fuse section <a href="#">on Page 23</a> .
	Faulty supply wiring.	Correct. Refer to certified electrical schematic.
Sampler does not cycle in either Auto or Manual modes (Power light ON).	Defective power switch.	Replace switch.
	Faulty system wiring.	Correct. Refer to certified electrical schematic.
	No or low air pressure.	Turn ON air supply and set regulator to 80-100 PSI.
Sampler cycles in Manual, but not in Automatic.	Defective control valve.	Refer to Air Components Troubleshooting section <a href="#">on Page 34</a> .
	Jumper between controller terminals 1 and 2 not installed.	Install jumper or switch between controller terminals 1 and 2.
Sample size too small or large.	Solenoid time on setting too low or high.	Adjust time setting. Refer to Manual PNEG-2170.
Sampler sluggish (Operates too slowly).	Inadequate air supply.	Increase line size or add surge tank.
	Regulator set too low.	Reset. Refer to Air Filter/Pressure Regulator section <a href="#">on Page 26</a> .
	Filter clogged.	Clean as outlined in Draining and Servicing the Filter section <a href="#">on Page 29</a> .
	Airline from filter regulator blocked or damaged.	Inspect and correct.
	Cylinder seal leakage.	Refer to Cylinder Leaking section <a href="#">on Page 34</a> .
Sampler leaks air or material continuously out the sample discharge.	Packing seals not tight.	Tighten. Refer to Adjustment of Seal Pressure section <a href="#">on Page 29</a> .
	Packing seals worn out.	Inspect and replace. Refer to Seal Replacement section <a href="#">on Page 30</a> .
	Sample probe worn out.	Inspect and replace. Refer to Sample Probe and Seal Replacement section <a href="#">on Page 31</a> .
Sample probe does not extend or retract.	No or low air pressure.	Turn ON air supply and set regulator to 80-100 PSI.
	Defective control valve.	Refer to Air Components Troubleshooting section <a href="#">on Page 34</a> .
	Material caked up in seals.	Inspect and replace. Refer to Seal Replacement section <a href="#">on Page 30</a> .
	Defective air cylinder seals.	Inspect and replace. Refer to Cylinder Leaking section <a href="#">on Page 34</a> .
	Sample probe bent or jammed.	Inspect and replace. Refer to Sample Probe and Seal Replacement section <a href="#">on Page 31</a> .

**NOTE:** PT samplers program mode to be set to "1" (one). Refer to controller manual PNEG-2170.



## Directional Solenoid Valve Troubleshooting

Problem	Possible Cause	Corrective Action
Valve does not shift but full line voltage signal is present at terminal TB1-8.	No or low air pressure.	Turn ON air supply and set regulator to 80-100 PSI.
	Faulty field wiring.	Check for full line voltage at the solenoid.
	Solenoid coil burnt out.	Replace coil if no continuity through coil.
	Valve clogged or stuck.	Remove and clean or replace.
Valve leaks air continuously out an exhaust port.	Defective valve seals.	Refer to Cylinder Leaking section <a href="#">on Page 34.</a>
	Defective cylinder seals.	Refer to Cylinder Leaking section <a href="#">on Page 34.</a>

There must be at least 60 PSI pressure at the valve. The valve pilot operators are air assisted. If there is insufficient pressure the valve will not shift or may not shift completely.

Observe the pressure gauge. Assume the gauge indicates sufficient pressure when the sampler is idle, 85 PSI for example. If the pressure drops significantly to perhaps 55 PSI when the valve shifts, a blocked or damaged air line should be suspected.

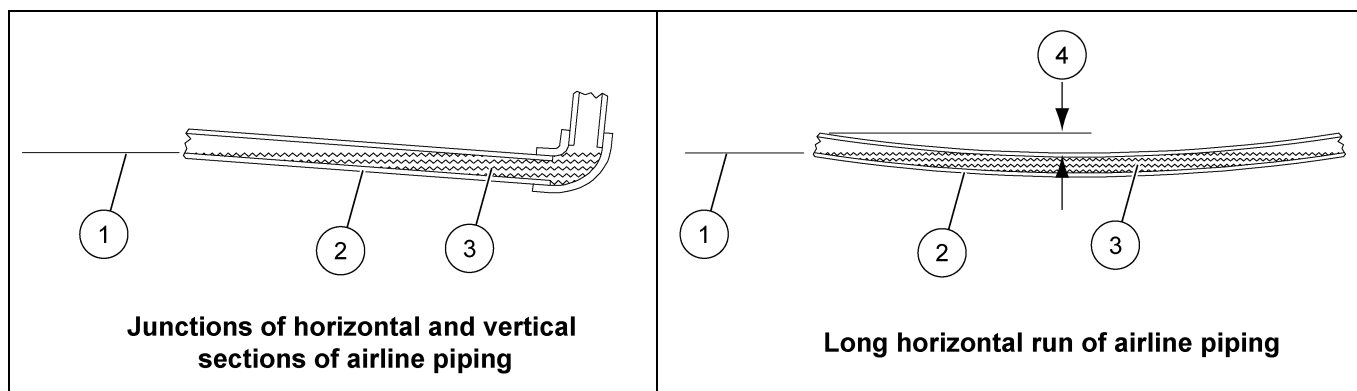

**Figure 8A** *Condensed Moisture Blocking Airline*

Ref #	Description
1	Water Level
2	Airline
3	Condensed Moisture
4	Sag of Pipe Greater than Internal Diameter

## 8. Troubleshooting

---

One often overlooked cause of insufficient air flow is moisture condensing and collecting in a low spot in the supply line. *Figure 8A on Page 33* illustrates an exaggerated example of such a problem. It can be seen that if the pipe sags only slightly over a long distance and water collects in the low spot over an extended period of time, the airline could be partially or completely blocked. A similar condition often occurs where there is a junction of horizontal and vertical sections of an air line.

This problem is particularly prevalent when there is high ambient humidity and the equipment operates infrequently and intermittently, as in the case of a sampler.

**NOTE:** *All horizontal runs of an airline should have a moisture trap and the traps should be drained frequently; at least once a day; especially, when humidity levels are high.*

## Air Components Troubleshooting

### Cylinder Leaking

#### 1. External Leakage

- a. Rod seal leakage can generally be traced to worn or damaged seals. Examine the piston rod for wear or damage. Replace the rod and seals if the rod's surface is rough or worn out-of-round.
- b. Soft or gummy seals are evidence of incompatibility with some substance in the air supply. Evaluate the area where the air intake is located. If an airline lubricator is included in the system, check to see if the lubricant being used is compatible with the seal material.

#### 2. Internal Leakage

- a. The lipseal piston seals are virtually leak free unless they are worn or damaged. Replace defective seals.
- b. Contaminants in the air supply can lead to scored cylinder walls, resulting in rapid seal wear. If such is the case, check to see if the filter is being drained frequently. A different type of filter may be required; one that can remove finer particles or one that can filter out different kinds of contaminants.
- c. Possible piston cylinder leakage, apparently indicated by piston drift is not always traceable to the piston. A leak through a closed valve port can also cause piston drift.

To determine if the cylinder piston is leaking (cylinder is bypassing), remove the cylinder retract hose from port "4" of the valve. This is the hose from the nose (piston rod) end of the cylinder. Use the valve's manual override to extend the cylinder. When the cylinder is fully extended, if air leaks from the retract port hose, the cylinder is bypassing. The cylinder will need to be repaired or replaced.

## Valve vs. Cylinder Leak Test

When there is continuous leakage out of a valve exhaust port, proceed as follows to determine if the leak is caused by defective valve seals or by defective cylinder seals.

1. Cylinder retracted as shown *Detail 1* in *Figure 8B*.
  - a. If there is continuous leakage out of Port “5”, the valve seals are defective and must be replaced.
  - b. If there is continuous leakage out of Port “3”, the problem can be with the valve seals or the cylinder seals. To determine which proceed as follows:
    - i. Disconnect the line between Valve Cylinder Port “2” and the cylinder per *Detail 2* in *Figure 8B*.
    - ii. If leakage continues out of Port “3” and/or Cylinder Port “2”, the valve seals are defective and must be replaced.
    - iii. If there is a leakage out of the line from the cylinder, the cylinder seals are defective and must be replaced.
2. Cylinder extended as shown *Detail 3* in *Figure 8B*.
  - a. If there is continuous leakage out of Port “3”, the valve seals are defective and must be replaced.
  - b. If there is continuous leakage out of Port “5”, the problem can be either the valve seals or the cylinder seals. To determine which proceed as follows:
    - i. Disconnect the line between Valve Cylinder Port “4”, and the cylinder per *Detail 4* in *Figure 8B*.
    - ii. If leakage continues out of Port “5” and/or Cylinder Port “4”, the valve seals are defective and must be replaced.
    - iii. If there is a leakage out of the line from the cylinder, the cylinder seals are defective and must be replaced.

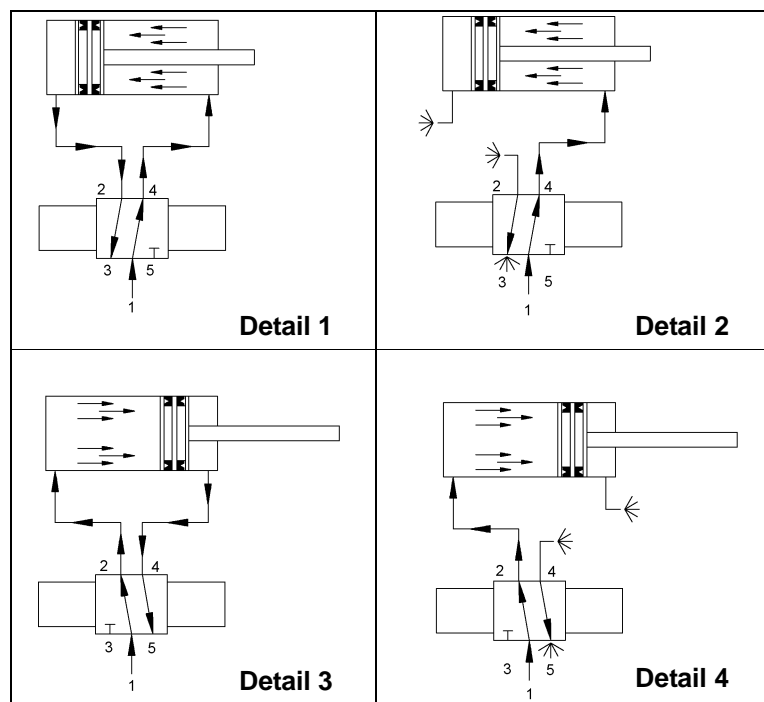

**Figure 8B** Valve Vs. Cylinder Leak Test Diagram

## 9. Optional Purge Configurations

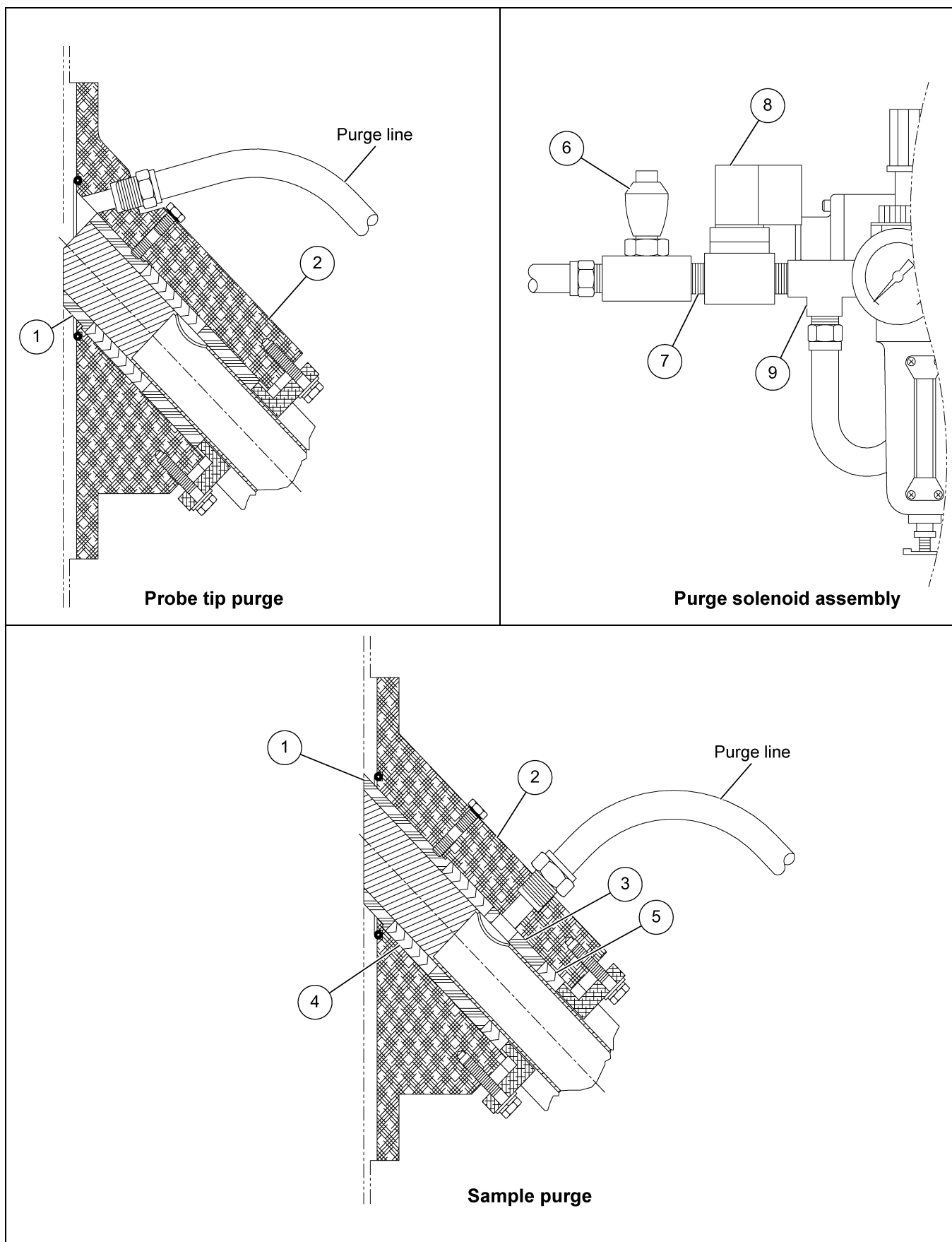

Figure 9A *Optional Purge Configurations*

Optional Purge Parts Listing

Ref #	Part #	Description	Qty
1		Replaces Standard Front Spacer	
	515926	PS-4 Purge Seal Spacer Nylon	1
	522923	PS-4 Purge Seal Spacer 304SS	1
	20227-41	PS-6 Purge Seal Spacer Nylon	1
	523950	PS-6 Purge Seal Spacer 304SS	1
	20228-41	PS-8 Purge Seal Spacer Nylon	1
	522481	PS-8 Purge Seal Spacer 304SS	1
	516300	PS-10 Purge Seal Spacer Nylon	1
	523951	PS-10 Purge Seal Spacer 304SS	1
	516299	PS-12 Purge Seal Spacer Nylon	1
	523952	PS-12 Purge Seal Spacer 304SS	1
2	514724	Brass Pipe Nipple 1/4" x 2-1/2" LG	1
3	510545	Brass 90° Street Elbow 1/4"	1
4	28196	1/4" Needle Valve	1
5	512823	Brass Pipe Close Nipple 3/8"	1
6	24553	3/8" Push-Loc to 3/8" MPT Street	1
	515679	2-Way Solenoid Valve 3/8" NPT	1
8	515877	2-Way XP Solenoid Valve 3/8" NPT	1
	24552	3/8 Push-Loc to 1/4" MPT Street	1
	513300	Lantern Ring 1-1/2" x 2-1/8" x 1/4" Nylon	1
	525574	Lantern Ring 1-1/2" x 2-1/8" x 1/4" 304SS	1
9	34423	Brass Pipe Tee 3/8" NPT	1
	24550	3/8" I.D. Air Hose	4'
		Replaces Standard Housing or Spacer	
	20225-40	PS-4 Seal Housing with Down Purge	1
	515923	PS-4 Seal Housing with R-L Purge	1
	517723	PS-8 Seal Housing with R-L Purge	1
	20228-40	PS-10/12 Housing Spacer with Sample Purge	1
	525267	PS-8 Seal Housing with Lantern Ring Purge	1
	525623	PS-10/12 Housing Spacer with Lantern Ring Purge	1

Refer to certified drawing(s) for specific options.

PT Sampler 5-1/2" Stroke Vertical Flow Side Section View (524075)

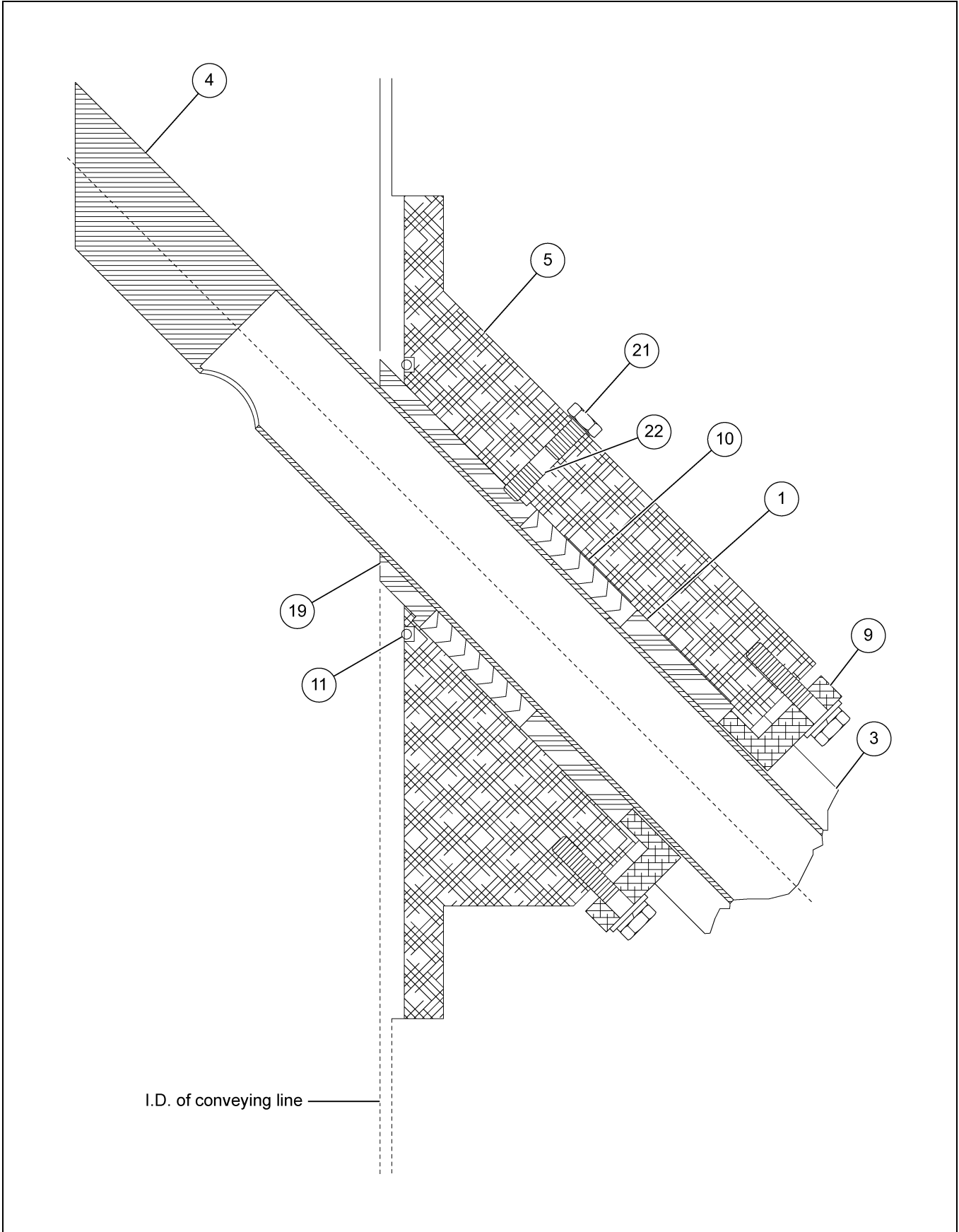

I.D. of conveying line

# PT Sampler 5-1/2" Stroke Horizontal Flow Side Section View (524076)

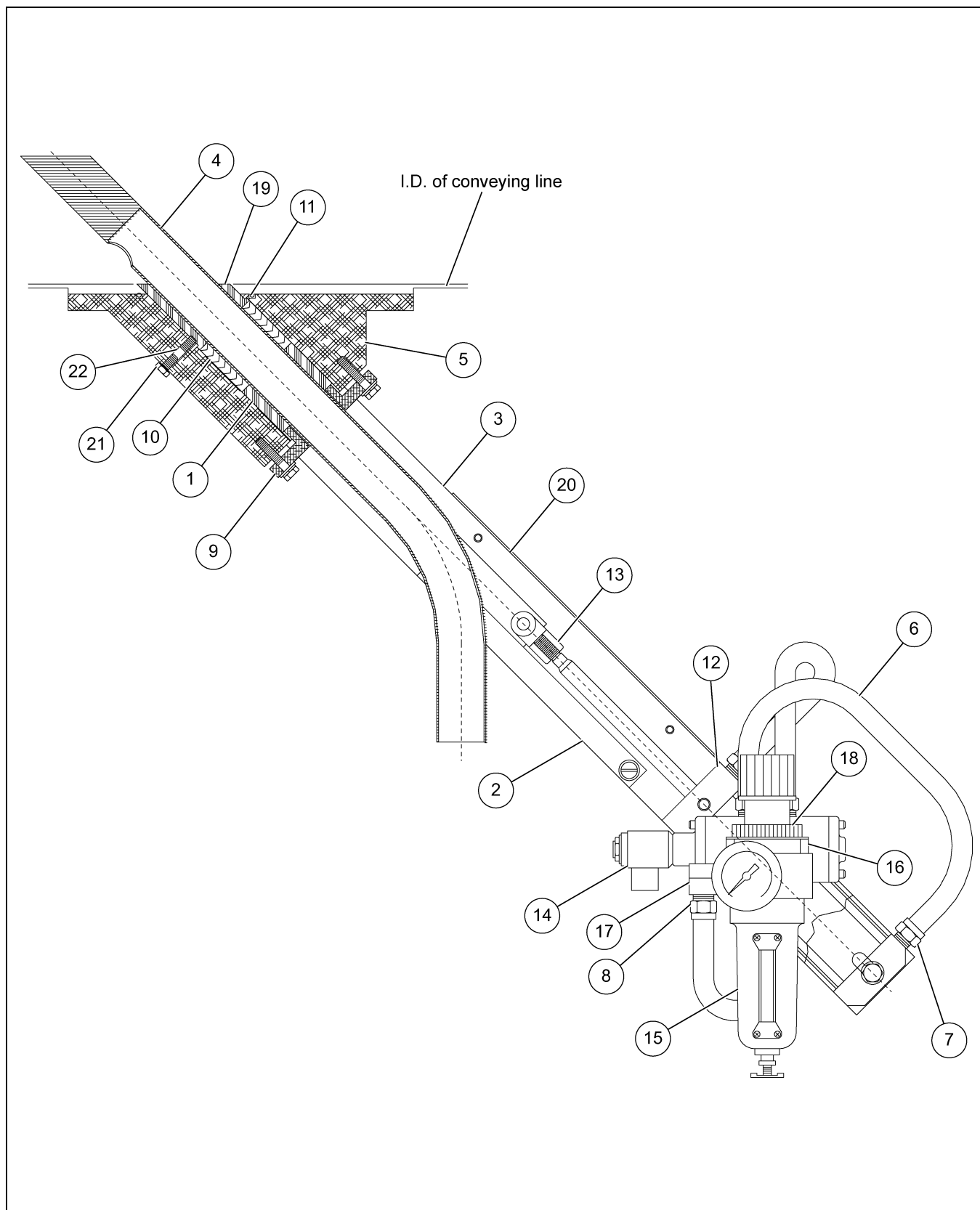

## 10. Parts List

### PT Sampler 5-1/2" Stroke Parts List

Ref #	Part #	Description	Qty
1	20230-04	Seal Spacer PT 1-3/4" LG	1
	527139	Seal Spacer 304SS	1
2	20230-06	Sample Guide PT	2
3	20230-09	Cylinder Mount Rail PT	2
4	20230-11	Probe PT Horizontal Flow	1
	20230-13	Probe PT Opposite Horizontal Flow	1
	20230-14	Probe PT Down Flow	1
	20230-15	Probe PT Up Flow	1
5	20230-33	Seal Housing PT Machined	1
6	24550	Hose Air 3/8" I.D. Push-Loc	4'
7	24552	Fit Air Push-Loc 3/8" x 1/4" MPT Street	2
8	24553	Fit Air Push-Loc 3/8" x 3/8" MPT Street	4
9	27040	Compression Plate	1
10	27104	CVH Seal Set 1-1/2" x 2-1/8" x 1.885"	1
11	27211	O-Ring 3-1/4" x 3-1/2" Buna-N	1
12	28007	Cylinder Air 2B x 5.5 STK	1
13	28152	Rod Clevis and Pin	1
14	543184	Valve, Air 3/8" NPT 120V 2 Position 4 Way	1
	545677	Valve, Air 3/8" NPT 120V 2 Position 4 Way Single	1
15	543180	Filter Regulator 3/8" NPT assembly 125	1
16	543183	Filter Regulator Mounting Bracket	1
17	34451	Pipe Street Elbow 3/8" NPT 90°	1
18	543182	Filter Regulator Mount Nut	1
19	514779	Packing Seal Retainer PT 3 SCH 40	1
	514780	Packing Seal Retainer PT 3-1/2" SCH	1
	514781	Packing Seal Retainer PT 3-1/2" SCH	1
	514782	Packing Seal Retainer PT 4 SCH 10	1
	514783	Packing Seal Retainer PT 4 SCH 40	1
	514784	Packing Seal Retainer PT 5 SCH 10	1
	514785	Packing Seal Retainer PT 5 SCH 40	1
	514786	Packing Seal Retainer PT 6 SCH 10	1
	514787	Packing Seal Retainer PT 6 SCH 40	1
	514788	Packing Seal Retainer PT 8 SCH 10	1
	514789	Packing Seal Retainer PT 8 SCH 40	1
	525637	Packing Seal Retainer PT 12 SCH 10	1
	525638	Packing Seal Retainer PT 12 SCH 40	1
	20	518371	Guard Sample Tube PT
21	522874	Bolt Hex 1/4"-20 UNC x 1/2" LG Sealing	1
22		1/4"-20 UNC Set Screw	1



InterSystems, Inc. reserves the right to make changes in design or in construction of equipment and components without obligation to incorporate such changes in equipment and components previously ordered.

**WARRANTY, LIMITATION OF LIABILITY, DISCLAIMER OF IMPLIED WARRANTIES:** InterSystems, Inc. manufactured equipment and components are guaranteed against defects in workmanship or materials for one year from date of shipment. The obligation of InterSystems, Inc. with respect to any goods is limited to replacement or repair of defective parts and equipment provided those parts are returned, shipping costs prepaid, to InterSystems' factory and provided the product has not been subject to misuse, negligence, or accident, or repaired or altered outside of our factory, or other than by an Authorized Service Representative. This warranty does not cover the replacement of parts inoperative because of wear occasioned by use, the cost of replacing parts by a person other than an InterSystems employee or an Authorized Service Representative, or the adjustment of a product where the product was improperly adjusted by the purchaser. In addition, this warranty does not cover components manufactured by others such as motors, drives, clutches, cylinders, valves, blowers, and the like. On those components the standard Manufacturers' warranty applies. In any event, liability is limited to the purchase price paid, and InterSystems, Inc. will, under no circumstances, be responsible for special or consequential damages, or for incidental damages.

**INTERSYSTEMS, INC. NEITHER MAKES NOR AUTHORIZES ANY WARRANTY OTHER THAN AS HEREIN CONTAINED. THIS WARRANTY IS IN LIEU OF ALL OTHER WARRANTIES, EXPRESS OR IMPLIED, INCLUDING THOSE OF MERCHANTABILITY AND FITNESS FOR A PARTICULAR PURPOSE.**

This equipment shall be installed in accordance with the current installation codes and applicable regulations, which should be carefully followed in all cases. Authorities having jurisdiction should be consulted before installations are made.



**InterSystems**  
9575 N. 109<sup>th</sup> Ave.  
Omaha, Nebraska 68142  
Toll Free: (800) 228-1483  
[www.gsiag.com](http://www.gsiag.com)



InterSystems is a part of GSI, a worldwide brand of AGCO Corporation.