

Sampler

Model: HD-PP

Installation and Operation Manual

PNEG-2227

Version: 1.0

Date: 05-02-18



All information, illustrations, photos, and specifications in this manual are based on the latest information available at the time of publication. The right is reserved to make changes at any time without notice.

Contents

Chapter 1 Introduction	5
General Safety Statements	5
Scope	5
Ordering Parts	6
Replacement Parts	6
Repair Kits	6
Chapter 2 Safety	7
Safety Guidelines	7
Cautionary Symbol Definitions	8
Safety Cautions	9
Safety Sign-Off Sheet	12
Chapter 3 Decals	13
Chapter 4 General Information	17
System Description	17
Optional Features	18
Material Sampled	18
Sampler Construction	18
Chapter 5 Installation	19
Receiving Inspection	19
Pre-Installation Preparation	19
Location	19
General Mounting Guidelines	19
Material Sample Transport Lines	22
Controller Location	22
System Wiring	22
System Piping	23
Chapter 6 Operation and Adjustments	25
Control Components and their Functions	25
Sampler Mounted Electrical Components	28
Pneumatic Components	29
Chapter 7 Maintenance and Repair	33
General Maintenance	33
Periodic Inspection	33
Lubrication	33
Draining and Servicing the Filter	34
Mechanical Repair Procedures	34
Chapter 8 Troubleshooting	39
General HD-PP Sampler Troubleshooting	39
PC Board Troubleshooting	40
Directional Solenoid Valve Troubleshooting	41
Air Components Troubleshooting	42
Chapter 9 Teflon and Purge Configurations	44
Teflon Seal Spacer Arrangements (6" and 8" Strokes)	44
Teflon Seal Spacer Arrangements (10" and 12" Strokes)	45

Table of Contents

Chapter 10 Parts List	46
HD-PP-6 Samplers 6" Stroke (525004)	46
HD-PP-8 Samplers 8" Stroke (525005)	48
HD-PP-10 Samplers 10" Stroke (525006)	50
HD-PP-12 Samplers 12" Stroke (525007)	52
HD-PP Motor Configuration View (525011)	54
Chapter 11 Warranty	55

This manual covers the installation and operation for the Sampler Model HD-PP. This manual provides guidelines for installing the product. You must retain a qualified contractor to provide on-site expertise. INTERSYSTEMS IS NOT RESPONSIBLE FOR THE INSTALLATION OF THIS PRODUCT.

InterSystems reserves the right to improve its product whenever possible and practical to do so. We reserve the right to change, improve and modify products at any time without obligation to make changes, improvements and modifications on equipment sold previously.

General Safety Statements

1. The Sampler system is designed and manufactured with operator safety in mind. However, residual hazards remain due to the nature of material handling, and specific material hazards. Use extreme caution at all times.
2. Modifications to equipment may cause extremely dangerous situations that could result in damage to the equipment as well as serious injury or death. Never modify the equipment.
3. InterSystems recommends that you contact the local power company to have a representative survey the installation to ensure wiring is compatible with their system and adequate power is supplied to the unit.
4. Consult InterSystems before making any changes to the sampler or its operating environment. Careless changes could result in death or serious injury to people and reduce the performance and service life of the equipment.
5. Never perform any service on this equipment or any other powered equipment until all power has been shut off and locked out so that it cannot be restored without the consent and knowledge of the person who interrupted power. Power includes electrical, fluid, mechanical or pneumatic energy.
6. Never perform any service on this equipment without utilizing the required PPE (Personal Protective Equipment). Refer to the MSDS (s) (Material Safety Data Sheet (s)), on all products to which this equipment is in contact to determine what PPE is required.



This equipment is to be operated only on the voltage designated on the certified electrical drawings. Fire or explosion may result, which can cause death, serious injury and extensive damage to equipment. Do not connect to voltages other than designated.



Compressed air can cause severe injury. Shut off and lock out compressed air source to the sampler and bleed off any and all present compressed air within the sampler pneumatics before attempting any service on this sampler.

Scope

The certified drawings list the non-standard components that have been incorporated into the equipment. InterSystems, Inc. normally stocks non-fabricated parts and non-custom OEM parts. Replacement parts for any other components, including fabricated parts and custom OEM components can be supplied upon request.

1. Introduction

Ordering Parts

Direct parts orders or requests for technical assistance to your sales representative or to:

InterSystems, Inc.
9575 N. 109th Ave
Omaha, NE. 68137
Phone: (402) 330-1500
FAX: (402) 330-3350

Please have available the MODEL NUMBER, SERIAL NUMBER and CUSTOMER ORDER NUMBER of the equipment in question as well as the location where the sampler is INSTALLED.

Replacement Parts

The InterSystems, Inc. sampler is a quality built piece of machinery. As with any machine, parts do wear out and fail. It is InterSystem's recommendation that a small supply of spare parts be kept on hand to cover any minor breakdowns. A separate priced spare parts list will be sent identifying the suggested spare parts. It is also necessary to check the certified drawings, which will list any special or custom components utilized on this equipment.

Repair Kits

The following chart lists repair kits and parts that are available from InterSystems. These kits are offered as a more economical solution by rebuilding the defective part rather than replacing it. However in some cases the part may be beyond repair and replacement will be necessary.

Part #	Description
525445	Spool Kit for 4-Way Directional Valve (ISI 500 Series)
28166	Standard 120 VAC Valve Coil (ISI 500 Series)
527134	Rod Seal Kit for 1-3/8" Rod Air Cylinder (Parker 2MA Series)
527855	Piston Seal Kit for 6" Bore Air Cylinder (Parker 2MA Series)
513963	Gauge for Filter Regulator
524711	Filter Element Kit for Filter Regulator (SMC NAW4000 Series)
34769	Standard SAE 80W-90 EP Gear Lubricant Oil Quart (Pennzoil 4096)
529601	Optional Synthetic Gear Lubricant Oil Quart (Mobil SHC634)
35527	Limit Switch Contact Block 1 N.O. 1 N.C.

Safety Guidelines

Safety guidelines are general-to-specific safety rules that must be followed at all times. This manual is written to help you understand safe operating procedures and problems that can be encountered by the operator and other personnel when using this equipment. Save these safety guidelines for future reference.

As owner or operator, you are responsible for understanding the requirements, hazards, and precautions that exist and to inform others as required. Unqualified persons must stay out of the work area at all times.

Alterations must not be made to the equipment. Alterations can produce dangerous situations resulting in **SERIOUS INJURY** or **DEATH**.

This equipment must be installed in accordance with the current installation codes and applicable regulations, which must be carefully followed in all cases. Authorities having jurisdiction must be consulted before installations are made.

When necessary, you must consider the installation location relative to electrical, fuel and water utilities.

Personnel operating or working around equipment must read this manual. This manual must be delivered with equipment to its owner. Failure to read this manual and its safety instructions is a misuse of the equipment.

ST-0001-3

Cautionary Symbol Definitions

Cautionary symbols appear in this manual and on product decals. The symbols alert the user of potential safety hazards, prohibited activities and mandatory actions. To help you recognize this information, we use the symbols that are defined below.



This symbol indicates an imminently hazardous situation which, if not avoided, **will result in serious injury or death.**



This symbol indicates a potentially hazardous situation which, if not avoided, **can result in serious injury or death.**



This symbol indicates a potentially hazardous situation which, if not avoided, **can result in minor or moderate injury.**



This symbol is used to address practices not related to personal injury.



This symbol indicates a general hazard.



This symbol indicates a prohibited activity.



This symbol indicates a mandatory action.

ST-0005-2

Safety Cautions

Use Personal Protective Equipment

- Use appropriate personal protective equipment:

Eye Protection



Respiratory Protection



Foot Protection



Hearing Protection



Head Protection



Fall Protection



Hand Protection



- Wear clothing appropriate to the job.
- Remove all jewelry.
- Tie long hair up and back.

ST-0004-1

Follow Safety Instructions

- Carefully read all safety messages in this manual and safety signs on your machine. Keep signs in good condition. Replace missing or damaged safety signs. Be sure new equipment components and repair parts include the current safety signs. Replacement safety signs are available from the manufacturer.
- Learn how to operate the machine and how to use controls properly. Do not let anyone operate without instruction.
- If you do not understand any part of this manual or need assistance, contact your dealer.



ST-0002-1

2. Safety

Maintain Equipment and Work Area

- Understand service procedures before doing work. Keep area clean and dry.
- Never service equipment while it is operating. Keep hands, feet, and clothing away from moving parts.
- Keep your equipment in proper working condition. Replace worn or broken parts immediately.



ST-0003-1

Stay Clear of Hoisted Equipment

- Always use proper lifting or hoisting equipment when assembling or disassembling equipment.
- Do not walk or stand under hoisted equipment.
- Always use sturdy and stable supports when needed for installation. Not following these safety precautions creates the risk of falling equipment, which could crush personnel and cause serious injury or death.



ST-0047-1

Sharp Edge Hazard

- This product has sharp edges, which can cause serious injury.
- To avoid injury, handle sharp edges with caution and always use proper protective clothing and equipment.



ST-0036-2

Install and Operate Electrical Equipment Properly

- Electrical controls must be installed by a qualified electrician and must meet the standards set by applicable local codes (National Electrical Code for the US, Canadian Electric Code, or EN60204 along with applicable European Directives for Europe).
- Lock-out power source before making adjustments, cleaning, or maintaining equipment.
- Make sure all equipment and bins are properly grounded.



ST-0075-1

Rotating Auger Hazard

- Keep clear of rotating augers and moving parts.
- Do not remove or modify guards or covers.
- Lock-out power source before making adjustments, cleaning, or maintaining equipment.
- Failure to follow these precautions will result in serious injury or death.



ST-0037-1

Flying Material and High Pressure Air Hazard

- Flying material and/or high pressure air can cause severe eye injury or blindness.
- Wear safety glasses around operating equipment.



ST-0071-1

Stay Clear of Rotating Parts

- Do not service equipment while it is in operation.
- Entanglement in rotating parts or exposed belts will cause serious injury or death.
- Keep all shields and covers in place at all times.
- Lock-out power source before making adjustments, cleaning, or maintaining equipment.



ST-0072-1

2. Safety

Toxic Fume and Dust Hazard

- Do all work outside or in a well-ventilated area. Dispose of paint and solvent properly.
- Remove paint before welding or heating:
 - Avoid potentially toxic fumes and dust. Hazardous fumes can be generated when paint is heated by welding, soldering, or using a torch.
 - If you sand or grind paint, avoid breathing the dust. Wear an approved respirator.
 - If you use solvent or paint-stripper, remove stripper with soap and water before welding.
 - Remove solvent or stripper containers and other flammable material from area. Allow fumes to disperse at least 15 minutes before welding or heating.



ST-0043-2

Safety Sign-Off Sheet

Below is a sign-off sheet that can be used to verify that all personnel have read and understood the safety instructions. This sign-off sheet is provided for your convenience and personal record keeping.

Date	Employee Name	Supervisor Name

ST-0007

The safety decals on your equipment are safety indicators which must be carefully read and understood by all personnel involved in the installation, operation, service and maintenance of the equipment. To replace a damaged or missing decal, contact us to receive a free replacement.

InterSystems

9575 N. 109th Ave.
Omaha, Nebraska 68137
Phone: (402) 330-1500
FAX: (402) 330-3350

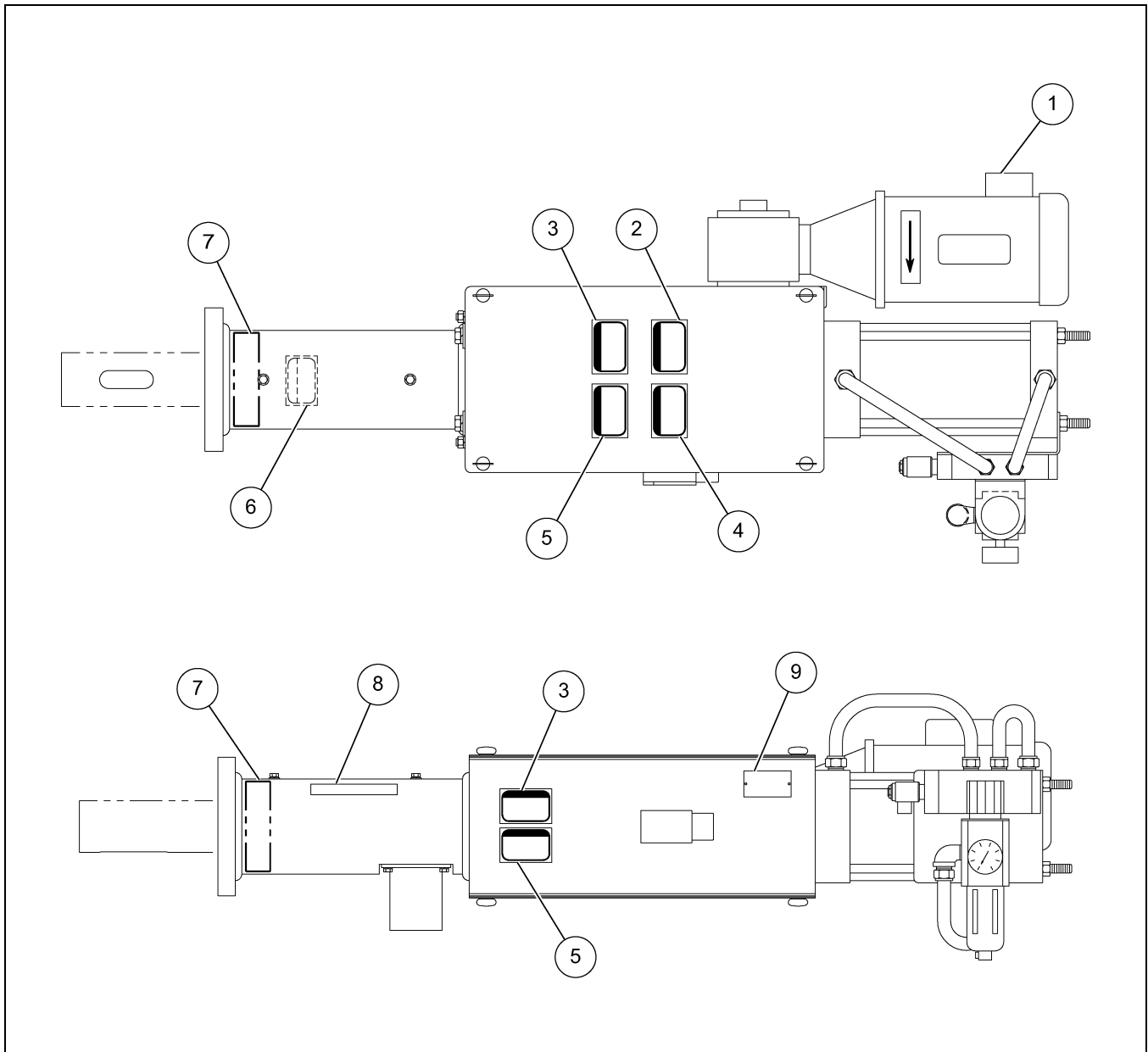
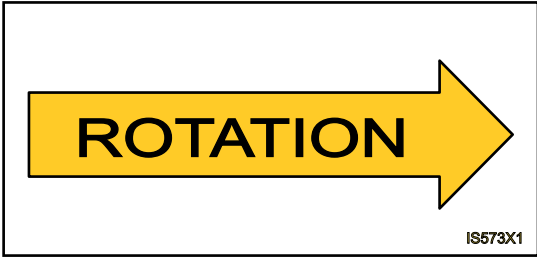

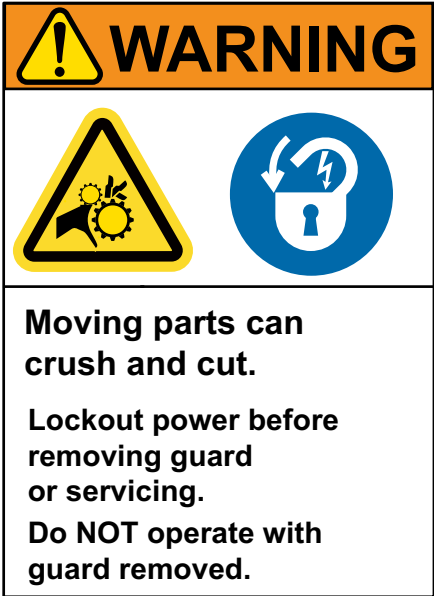

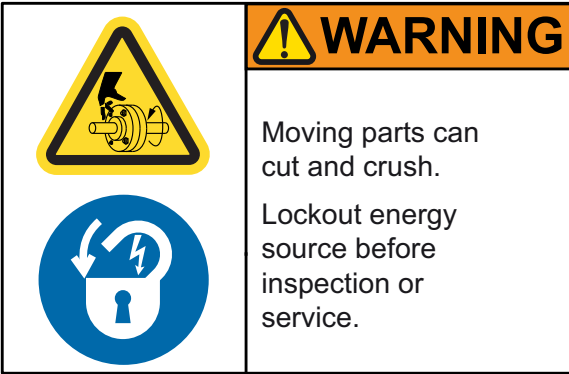
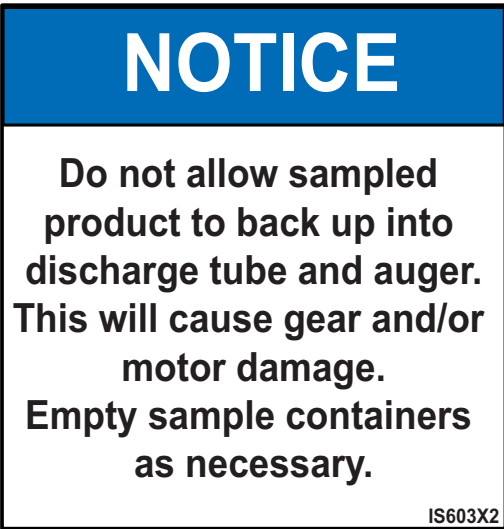

Figure 3A Model HD-PP Sampler Safety Label Locations



NOTE: These signs must never be removed, tampered with, painted over or obscured in anyway. If labels are damaged or become unreadable, replacement labels are available from InterSystems.

3. Decals

Ref #	Decal #	Decals	Description
1	IS574X3L		Rotation
2	EMC 40 232		Lock Out Machine
3	EMC 33 32		Exposed Gears (N.S., F.S)

Ref #	Decal #	Decals	Description
4	EMC 40 332	 <p>NOTICE</p> <p>THIS MACHINE STARTS WITHOUT WARNING</p> <p>EMC 40 332</p>	Starts Without Warning
5	EMC 30 32	 <p>WARNING</p> <p>Moving parts can cut and crush.</p> <p>Lockout energy source before inspection or service.</p> <p>© Clarion Clarionsafety.com Reorder No. EMC 3032</p>	Moving Part (N.S., F.S)
6	IS603X2	 <p>NOTICE</p> <p>Do not allow sampled product to back up into discharge tube and auger. This will cause gear and/or motor damage. Empty sample containers as necessary.</p> <p>IS603X2</p>	Empty Sample Containers (Opposite Side)

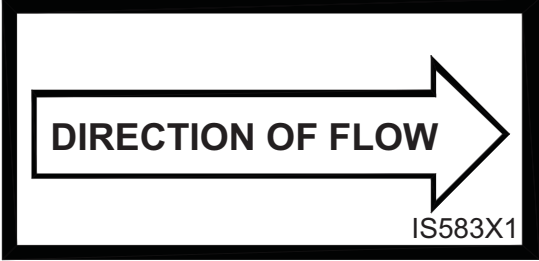
3. Decals

Ref #	Decal #	Decals	Description
7	IS583X1		<p>Direction of Flow (NOTE: Arrow on label aligned to match material flow direction as noted on assembly drawing of sampler)</p>
8	IS517X1		IS Sampler
9	IS Tag		IS Serial No Tag

System Description

The HD-PP Sampler is designed to collect a representative sample of granular, flake, powder, or other materials in a gravity or pressurized conveying line or from a hopper tank or pressure vessel. [Figure 4A](#) illustrates a typical HD-PP Sampler application.

Sample collection is initiated in response to either an operator's manual command or a signal automatically generated by controller logic, usually time-based but which could also be volume or quantity based. A sample cycle begins when a double-acting pneumatic cylinder forces the slotted sampling tube (probe) into the product line to collect a sample of the material. Next, the sample tube probe is withdrawn into the seal housing isolating the sample and sample tube cavity from the conveying line. Then, an electric motor operating through a set of bevel gears, rotates the auger through several revolutions, augering the sample collected to the 3.00" (76 mm) O.D. discharge outlet tube. The sample then falls down and out the discharge tube to the desired sample collection point, at which point an InterSystems SCS Sample Collection System (optional) may be installed.

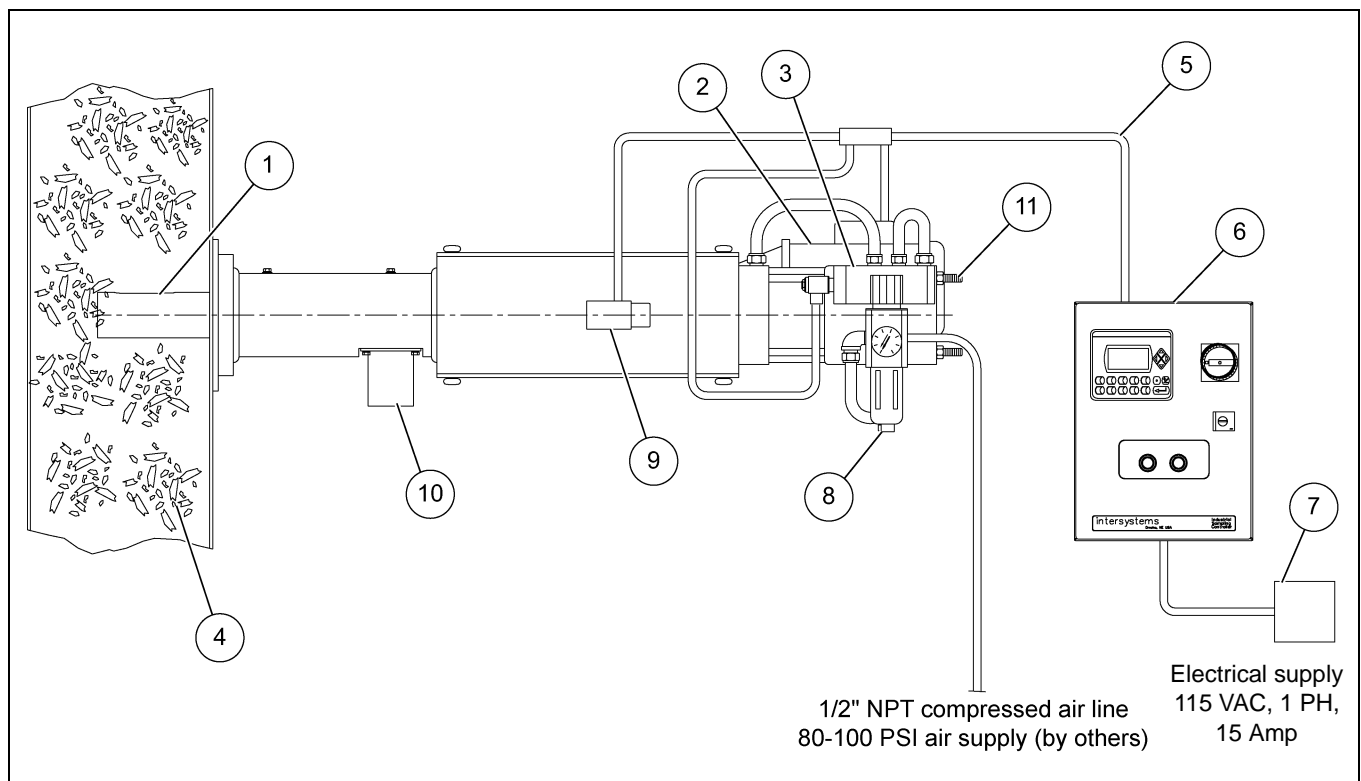

Figure 4A Typical Installation, Model HD-PP Sampling System

Ref #	Description
1	Sample Probe
2	Motor
3	Solenoid Valve
4	Material to be Sampled
5	Electrical Conduit
6	Sampler Control Panel

Ref #	Description
7	Circuit Breaker
8	Filter/Regulator
9	Limit Switch
10	Sample Discharge
11	Support hanger or bracket required (by others). Attach to the threaded tie rods of the air cylinder.

4. General Information

Optional Features

The certified drawings indicate which, if any, optional features are included with a sampling system. Some of the more frequently specified optional features are briefly described in the following list.

1. Controller arranged to initiate a sampling cycle based on quantity or volume of material passing through conveying line rather than upon elapsed time periods.
2. Explosion-Proof Sampling System. There are several major differences in an explosion-proof sampler as compared to a standard sampling system. An explosion-proof sampler will typically have the following features.
 - a. An explosion-proof solenoid on the directional control valve with the rating of:
 - Class 1, Groups C and D, Division 1 and 2
 - Class 2, Groups E, F and G, Division 1 and 2
 - b. An explosion-proof limit switch with the rating of:
 - Class 1, Groups C and D, Division 1 and 2
 - Class 2, Groups E, F and G, Division 1 and 2
 - c. An explosion-proof motor with the rating of:
 - Class 1, Groups D, Division 1 and 2
 - Class 2, Groups E, F and G, Division 1 and 2

The explosion-proof sampler control is available in two enclosure classifications.

- a. The NEMA 9 control with the rating of:
 - Class 2, Groups E, F and G, Division 1 and 2
 - b. The NEMA 7 control with the rating of:
 - Class 1, Groups C and D, Division 1 and 2
 - Class 2, Groups E, F and G, Division 1 and 2
3. Purge air systems to either aid in material discharging from the sampler or to prevent material from building up in V-ring packing seals.
 4. Components of special materials, such as 316 stainless steel, monel, inconel or nedox coatings.
 5. Programmable controls to sequence the sampler and the sample collection equipment.

Material Sampled

Most materials from light to heavy density powders, granules, flakes, viscous liquids and slurries.

Sampler Construction

Standard sampler housing construction is of painted aluminum. The sample probe, auger, gear housing and covers are of Type 304 Stainless Steel. The auger is 2-1/2" O.D., machined from a solid bar (no welds on flights) and hand polished. Other materials and/or finishes appropriate to the operating environment and the material or product being sampled may be used. Refer to the certified drawing(s) for any optional or special components installed on the sampler.

Receiving Inspection

Carefully inspect the sampling system for damage as soon as it is received. Also, verify that the quantity of parts or packages actually received corresponds to the quantity shown on the packing slip. Report any damage or shortage to the delivering carrier as soon as possible. InterSystems responsibility for the equipment ended with acceptance by the delivering carrier. Refer to the bill of lading.

Pre-Installation Preparation

NOTE: *Before starting sampling system installation, study this manual, the certified drawing(s) furnished with the system, and other applicable documents (including, but not limited to OSHA regulations; the National Electrical Code; and all other applicable federal, state, and local codes and regulations).*

Location

The HD-PP sampler is typically mounted horizontally onto a vertical or horizontal conveying line carrying the product to be sampled as shown in [Figure 4A on Page 17](#). The sampler axis must be installed perpendicular (at a 90° angle) to the axis of the product line for optimum performance. Additionally, the sampler should be located where the product has a non-turbulent flow pattern. The sampler and associated equipment should be located for ease of access and maintenance.

The sampler is to be installed only as shown on the certified drawing(s). If an alternate mounting arrangement is desired, contact InterSystems prior to installation for proper guidance. The sampler is of a general design with modifications specifically for your application. It may be necessary to rework the sampler in order for it to function properly if you alter the application.

General Mounting Guidelines

The sampler assembly is designed to support ONLY its own weight. As shown on the certified drawing of the sampler, the sampler must be installed with an additional hanger or bracket to rigidly support the sampler. The support can be attached the cylinder tie rods at the rear of the cylinder. The hanger or bracket should be capable of supporting approximately 300 lbs.



Sampler cannot support any other equipment or conveying line. Collapse of the whole system can cause death, serious injury, and extensive damage to equipment. Properly support all spouts, containers, and conveying lines.

NOTE: *If the surface area to which the mounting plate is to be attached is warped or bent, straighten and smooth the metal so the sampler will be properly aligned when the installation is complete. The surface to which the sampler is mounted must not flex. The sampler cylinder must be rigidly supported; any flexing will damage the sampler.*

NOTE: *Over tightening the mounting fasteners will warp or crack the seal housing flange. Improper sampling will result.*

5. Installation

Sampler without Optional Mounting Accessories

1. Locate and mark the desired mounting location on the product line.
2. Cut and deburr a 3-1/2" diameter hole in the product line through which the sample tube will pass to collect material samples.
3. The mounting flange on the end of the seal housing has four 0.562" (9/16") clearance holes for 1/2" mounting screws or studs. Using the sampler mounting face as a pattern, layout or transfer punch the hole locations onto the conveying line.
4. Drill and tap the holes for the mounting screws, or weld studs to the conveying line for fastening the sampler.
5. Ensure that the O-ring is seated in the groove on the sampler housing mounting flange and verify that the sample tube extends and retracts without interference.
6. Install the sampler on the mount surface and tighten the mounting fasteners to ensure proper sealing between the sampler seal housing and the product line.
7. If the conveying line is a pressure or vacuum line, check to see that the seal at the connection is airtight. Re-tighten fasteners if necessary.
8. The user or installer must provide a hanger or bracket to rigidly support the sampler. The support can be attached to the cylinder tie rods at the rear of the cylinder. The hanger or bracket should be capable of supporting approximately 300 lbs.

Factory Pre-Mounted Sampler

As furnished, the pre-mounted sampler is already firmly attached to a length of tube, pipe, etc.

1. Remove a section of pipe or chute work where the sampler is to be installed.
2. Remove the sampler from the sampler pre-mount.
3. Locate the sampler pre-mount in the desired position.
4. Attach the sampler pre-mount using one of the following methods.
 - a. Weld the sampler pre-mount ends directly to the existing pipe or chute work.
 - b. Clamp the sampler pre-mount ends to the existing pipe utilizing compression couplings.
 - c. Weld matching flanges to the existing pipe or chute work and sampler pre-mount.
5. Ensure that the O-ring is seated in the groove on the sampler housing mounting flange.
6. Install the sampler on the mount surface and tighten the mounting fasteners to ensure proper sealing between the sampler seal housing and the product line.
7. If the conveying line is a pressure or vacuum line, check to see that the seal at the connections are airtight. Re-tighten fasteners and/or re-weld if necessary.
8. The user or installer must provide a hanger or bracket to rigidly support the sampler. The support can be attached to the cylinder tie rods at the rear of the cylinder. The hanger or bracket should be capable of supporting approximately 300 lbs.

Field-Mounted Sampler Using Weld-On Plates

Weld-on plates are typically used when mounting the sampler to a large existing surface, such as on a storage hopper or a long section of chute work.

1. Locate and mark the desired mounting location on the conveying line.
2. Cut and deburr a 3-1/2" diameter hole in the conveying line through which the sample tube will pass to collect material samples.
3. Position the sampler mounting plate by aligning the 3-1/2" diameter sample probe clearance holes.
4. Tack weld the sides of the mounting plate to the product line surface and double check alignment.
5. Weld a continuous bead around all sides of the mounting plate.

NOTE: *When welding the mounting plate to thin gauge sheet or thin plate, skip weld alternating sides of the mounting plate to limit heat input to minimize warping.*

6. Ensure that the O-ring is seated in the groove on the sampler housing mounting flange and verify that the sample tube extends and retracts without interference.
7. Install the sampler on the mount surface and tighten the mounting fasteners to ensure proper sealing between the sampler seal housing and the product line.
8. If the conveying line is a pressure or vacuum line, check to see that the seals at the connections are airtight. Re-tighten fasteners and/or re-weld if necessary. If the weld leaks, remove the sampler and O-ring before making any repair welds. Weld heat will damage or destroy the gasket and the Teflon seals in the seal housing.
9. The user or installer must provide a hanger or bracket to rigidly support the sampler. The support can be attached to the cylinder tie rods at the rear of the cylinder. The hanger or bracket should be capable of supporting approximately 300 lbs.

Field-Mounted Sampler Using Clamp-Type Mounting Brackets

Clamp-type mounting brackets are used on round tube or pipe conveying lines.

1. Locate and mark the desired mounting location on the conveying line.
2. Cut and deburr a 3-1/2" diameter hole in the product line through which the sample tube will pass to collect material samples.
3. Make sure the 1/8" thick Neoprene gasket is in place inside the clamp adapter.
4. Position the clamp bracket by aligning the sample probe clearance holes and tighten the clamp fasteners.

NOTE: *Over tightening the bracket fasteners will distort the conveying line tube or pipe. The tube can crack or buckle, the sampler will not be properly aligned with the product stream, and in cases where the conveying line I.D. is nearly the same as the stroke of the sampler, the sample tube may actually strike the opposite side of the tube as it extends.*

5. Ensure that the O-ring is seated in the groove on the sampler housing mounting flange and verify that the sample tube extends and retracts without interference.

5. Installation

6. Install the sampler on the mount surface and tighten the mounting fasteners to ensure proper sealing between the sampler seal housing and the product line.
7. If the conveying line is a pressure or vacuum line, check to see that the seal at the mounting clamp is airtight. Tighten clamp fasteners if necessary.
8. The user or installer must provide a hanger or bracket to rigidly support the sampler. The support can be attached to the cylinder tie rods at the rear of the cylinder. The hanger or bracket should be capable of supporting approximately 300 lbs.

Material Sample Transport Lines

The tubing used to transport material samples must be compatible with the operating environment and the material sampled. Typically a 3.00" I.D. flexible hose is slipped over the discharge tube and held in place by a worm clamp. The hose is then routed to allow material to flow via gravity to a convenient collection point. At that point, the hose may be connected to a collection jar bracket or a Sample Collection System cabinet.

Rigid tubing or pipe may also be used if desired for sample transport lines.

Make all connections airtight and make sure all interior surfaces of joints are smooth and flush. Any ragged or raised tube ends will collect dust and debris as well as retard material flow. Air leaks can interfere with the pressure or vacuum conveying and sampling system. Escaping sample material can contaminate surrounding atmosphere and equipment.

Controller Location

1. Use vibration isolation pads when mounting the control enclosure or mount the controller in a vibration-free location.
2. Unless ordered for severe duty, locate controller so it is protected from water and dust.
3. Unless an explosion-proof rated controller was specifically ordered, DO NOT locate the controller in a hazardous area.
4. Most applications require that the sampler be in easy view of the controller.

System Wiring

Refer to the certified electrical drawing(s) for specific wiring requirements. As explained in Terminal Strip [on Page 26](#), the 19-position barrier terminal strip on the circuit board mounted INSIDE the controller enclosure is the connection point for ALL external circuitry.

The controller was completely assembled and tested with the sampler before it left the factory. The electrical installation must comply with OSHA Regulations; the National Electrical Code; and all other applicable federal, state, and local codes and regulations.

If wiring between the controller and the sampler unit is run through rigid conduit, use a short length of flexible conduit to connect wiring to the sampler. This will isolate the rigid conduit from any vibration originating in the product conveying line and sampler.

Electrical Power Requirements, System

110/120 VAC 50/60 Hz, Single Phase, 20 Amp Service

Optional - 220/240 VAC 50/60 Hz, Single Phase, 10 Amp Service

Refer to the certified electrical drawing(s) for specific wiring requirements. InterSystems strongly recommends that electrical service to the sampling system be an isolated line. Voltage fluctuations and line noise can affect the controller's circuit board, thus causing the sampler to malfunction.

Controller

110/120 VAC, 50/60 Hz, Single Phase, 14 Amp Max. (Includes motor power requirements.)

Optional - 220/240 VAC, 50/60 Hz, Single Phase, 7 Amp Max. (Includes motor power requirements.)

Solenoid Valve Coil

110/120 VAC, 50/60 Hz, Single Phase, 7 Watts

Optional - 220/240 VAC, 50/60 Hz, Single Phase, 7 Watts

Auger Drive Motor

Standard 110/120 VAC, 220/240 VAC, 50/60 Hz, Single Phase, 9.8/4.9 Full Load Amps.

System Piping

NOTE: Use only cleaned, pickled, descaled, and oiled pipe for air supply lines. Dirt, scale, and debris usually found in standard pipe quickly clogs filter/regulators, valves, etc. Use only Teflon tape to seal pipe joints. Carefully apply the tape to pipe and fittings so no fragments enter the system.

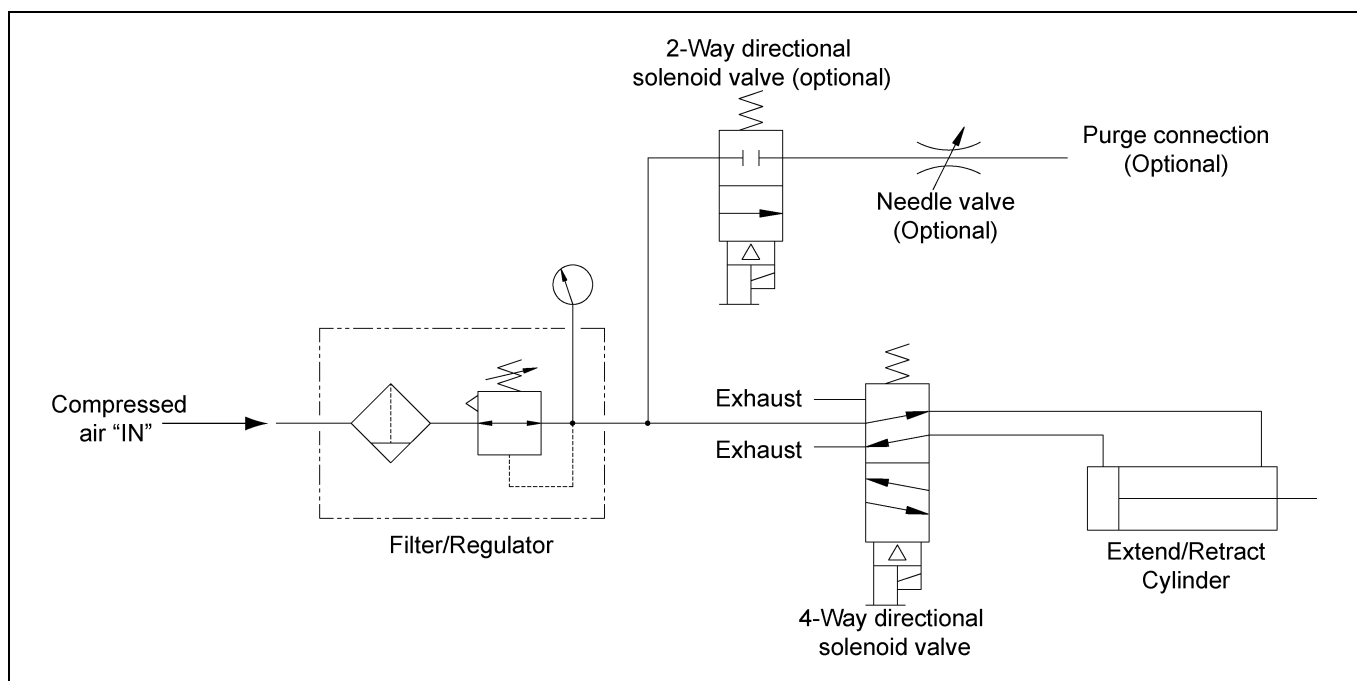

Figure 5A Pneumatic Schematic

5. Installation

The pneumatic system was pre-plumbed and tested with the sampler before it left the factory. The final installation must comply with OSHA Regulations and all other applicable federal, state, and local codes and regulations.

As shown on the certified drawing(s), the solenoid valves and filter/regulator (F/R) were mounted on the sampler at the factory. The user or installer must pipe the compressed air supply to the F/R. Minimum pipe size for the air supply to the filter/regulator is 3/4" NPT, reduced to 1/2" NPT at sampler. Larger piping to the sampler, and/or a surge tank located at the sampler, will be required on installations where the compressed air source is further than 200' from the sampler to prevent excessive drop in air pressure.

InterSystems recommends installing a lockable shut off valve upstream of the filter/regulator. The shut off valve facilitates maintenance as it allows the sampler's pneumatic system to be maintained and repaired without shutting down other equipment supplied from the same air source.

Compressed Air Consumption

A complete sampling cycle requires that the cylinder extend and retract and that the auger motor run the auger for a specified amount of time. To determine the compressed air requirements to operate the sampler, multiply the consumption per cycle (refer to chart) by the number of cycles per minute. The number calculated is the SCFM (Standard Cubic Feet per Minute) of air required. A typical cycle takes between 10-20 seconds, depending on the sampler size and control settings. The regulator cannot increase downstream outlet pressure above the upstream inlet pressure. If the pressure from the regulator is not sufficient to operate the cylinder, some means must be found to increase the inlet pressure to the regulator. Recommended air supply pressure is 80-100 PSI.

Model/Size	Air Consumption Per Sample Cycle @ 80 PSI
HD-PP-6	1.2 SCF
HD-PP-8	1.6 SCF
HD-PP-10	2.0 SCF
HD-PP-12	2.5 SCF
HD-PP-14	2.9 SCF
HD-PP-16	3.3 SCF
HD-PP-18	3.7 SCF

The pneumatic system on the sampler, consisting of the filter/regulator, directional control valve and air cylinder was pre-plumbed and tested at the factory. The regulator is factory set at 80 PSI.



Failure to observe all safety rules, written and implied and those suggested by common sense, can result in death, serious injury and/or equipment damage. Lock out power before performing any maintenance.

Control Components and their Functions

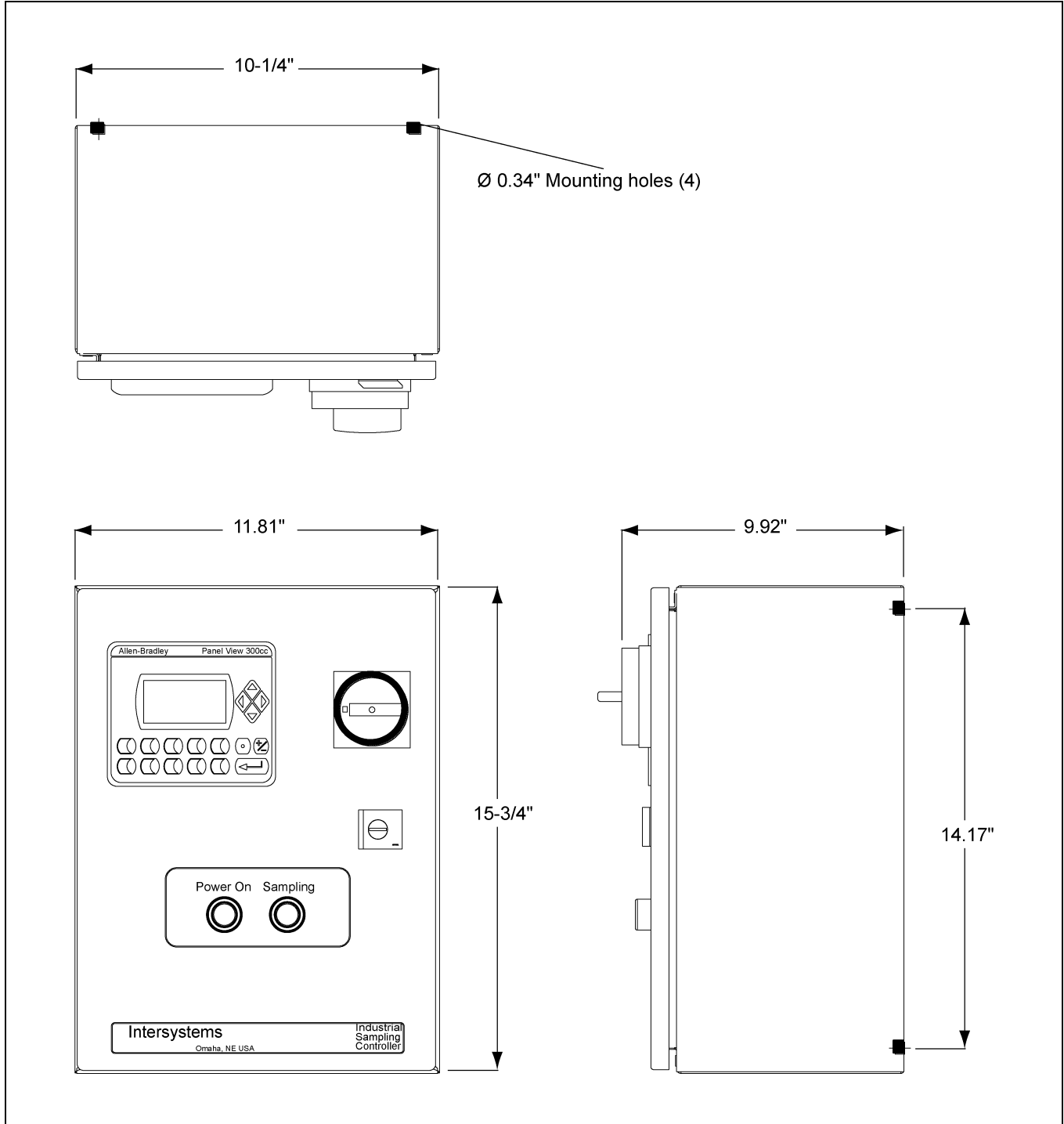

Figure 6A Standard NEMA 4 Control Panel Detail

Refer to the certified electrical drawing(s) for dimensions on control panels with optional features.

6. Operation and Adjustments

Power OFF/ON Switch (S1)

The power OFF/ON Switch controls the electrical power to the controller and the sampler.



This machine starts without warning. Moving parts can cause severe injury. Clear area prior to controller start-up.

Power Pilot Light

This light is illuminated as long as power is available to the controller and the POWER switch (S1) is set to ON.

Sampling Pilot Light

This light is illuminated when a sampling cycle has been initiated and will stay lit until the sampling cycle has completed.

Control Keypad

The operator keypad is the source of all inputs necessary to operate the control.

The operator keypad is set up using linked menus to step through the operation of the control.

Refer to the control manual PNEG-2170 for further information on the sampler control.

Main Fuse (FU1)

The fuse, located along the top center of the control, protects the controller and sampler components against overloads and short circuits.

For 110/120 VAC, 1 PH operation, use ONLY a BUSS Type FNM 2 Amp, 250 VAC Slo-Blo fuse or equivalent.

For 220/240 VAC, 1 PH operation, use ONLY a Buss Type FNM, 1 Amp, 250 VAC Slo-Blo fuse of equivalent.

Terminal Strip

This 19-position terminal strip is located along the bottom of the controller. It serves as the controller's interface and connection point for all external circuits and for the components mounted inside the enclosure. Refer to the certified electrical drawing(s).

Power Supply

The controller is equipped with a power supply which converts 120/240 VAC to 24 VDC for the operation of the PLC, Micro-View, display lights, input signals and the operation of the control relays. Refer to the certified drawing(s).

Control Relays

The controller is equipped with four control relays which are driven by the PLC 24 VDC outputs.

Each relay has a mechanical flag indicator showing the relay is energized.

The relay contacts are wired for 120/240 VAC. Refer to the certified drawing(s).

Micrologix PLC

The PLC for the control is an Allen Bradley Micrologix controller. The PLC operates using 24 VDC and is prewired to the proper terminal strip inputs and outputs. The processor program is protected to prevent any alterations to the existing program. This control is designed to run InterSystem equipment.

Manual Sampling

The operator may choose to run the sampler in Manual Mode by selecting manual mode in the PanelView menu. (Refer to manual PNEG-2170.) After selecting manual mode, each time F1 is pressed on the PanelView, a manual sample is initiated.

Automatic Sampling

The operator may choose to run the sampler in the Automatic Mode by selecting automatic mode in the PanelView menu. (Refer to manual PNEG-2170.) **NOTE:** *A jumper or switch must be installed between the controller's terminals 1 and 2 to initiate automatic sampling. When automatic mode is selected, an automatic sample will not be initiated until the jumper circuit between terminals 1 and 2. By installing a remote switch across terminals 1 and 2, the user can initiate the sampling cycle remotely. Refer to PNEG-2170 for sampling automatic sampling options.*



This control is to be operated only on the voltage designated on the certified electrical drawing. Fire or explosion may result, which can cause death, serious injury, and extensive damage to equipment. Do not change the 115/230 VAC switch setting without consulting InterSystems.

Sampler Mounted Electrical Components

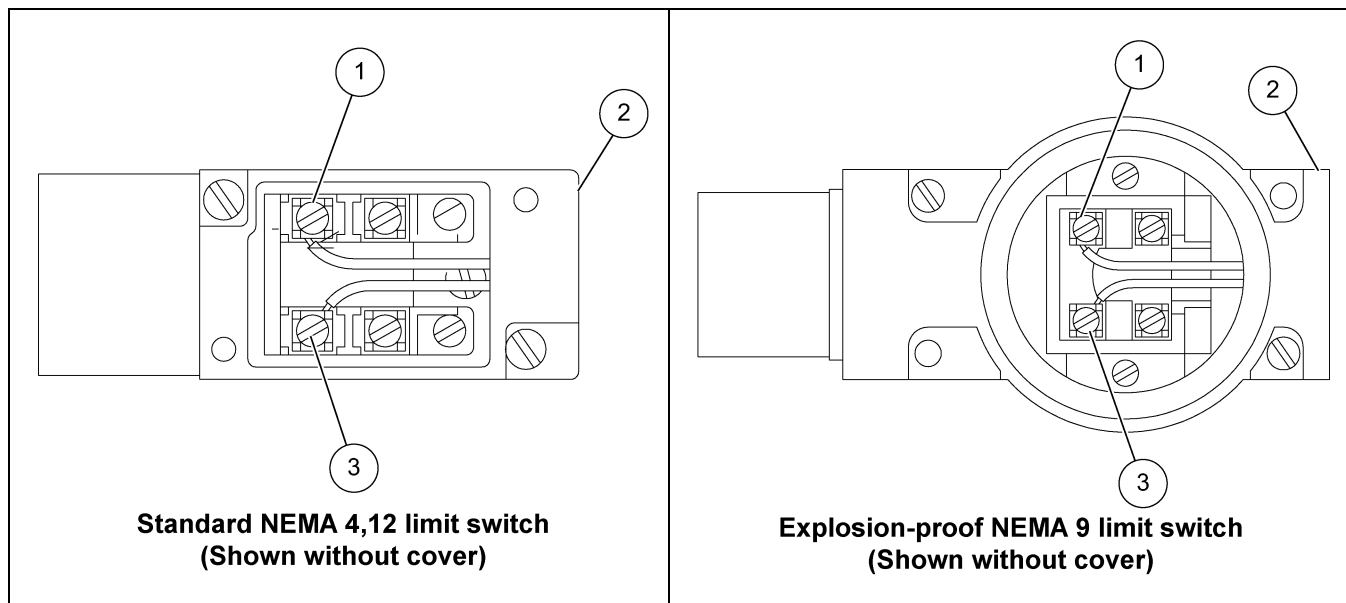

Figure 6B Limit Switch Connections

Ref #	Description
1	N.O. Contact Connection
2	1/2" NPT Conduit Connection
3	Common Connection

Limit Switch, LS-1

This switch is actuated when the sample probe is in its retracted position. Upon retraction of the sample probe the limit switch is actuated and the closure of the normally open contacts signals the controller to allow the auger motor to run.

Correct wiring termination is essential to proper sampler operation. Refer to [Figure 6B](#), it shows two models utilized on the HD-PP sampler and the physical orientation of the proper wiring connections.

Auger Drive Motor

This motor is direct coupled to the gear reducer and drives the sample auger through a set of right angle bevel gears. A label is located on the motor designating the correct direction of rotation. [\(See Figure 3A on Page 13.\)](#) Verify that the motor is turning the proper direction of rotation when wiring the system. On initial setup, test run the sampler when no material to be sampled is present. (Conveying line shut down, hopper empty, etc.) This will prevent the sample auger from jamming if the motor is running backwards.

NOTE: Do not run the motor in wrong direction. Extensive damage to the sampler will result.

Pneumatic Components

Solenoid Valves V-1

This valve is a 4-way, 2 position, spring return, single solenoid operated control valve. This valve controls the air cylinder, alternately pressurizing the cap end and rod end of the cylinder to extend and retract the sample tube.

When the valve's solenoid is energized, the internal valve spool shifts, pressurizing the cap end of the cylinder. The cylinder extends, pushing the sample probe into the product stream. When the solenoid is de-energized, the valve spring forces the valve spool to shift again, pressurizing the rod end of the cylinder. The cylinder retracts, pulling the sample probe from the product stream.

The valve has a manual over-ride button that allows the operator to cycle the sampler air cylinder without the aid of the controller. By pushing the manual over-ride button, the internal valve spool is positioned manually and the sampler air cylinder will extend and remain there until the button is released. When the over-ride button is released, the cylinder will return to its home position.

Needle Valve (Optional)

This valve regulates the air flow feeding the purge option. This valve will require some adjustment upon initial sampler start-up. [Figure 6C on Page 30](#) shows the two available purge configurations.

1. The "Sample Purge" type aids in the flow of material out of the sampler and into the sample container. This purge, which is controlled by the sample purge solenoid valve V-2, forces air into the sample probe.
2. The "Lantern Ring Purge" helps keep the material being sampled away from the sampler packing seals. This purge, which only has the needle valve for control, forces air continuously ahead of the probe seals to keep the sampled material from being forced into the seals.

Purge Solenoid Valve V-2 (Optional)

This valve operates the sample purge option. The valve is a 2-way, normally closed, spring return, single solenoid operated control valve. As shown in [Figure 6C on Page 30](#), it is plumbed in conjunction with the needle valve to correctly control the purge air flow. The purge solenoid is typically wired in parallel with sampler auger motor. When the sample auger is turning the purge air is being fed into the sample probe thus aiding in the flow of material out of the sampler. Refer to the certified electrical drawing(s) for proper wiring requirements.

6. Operation and Adjustments

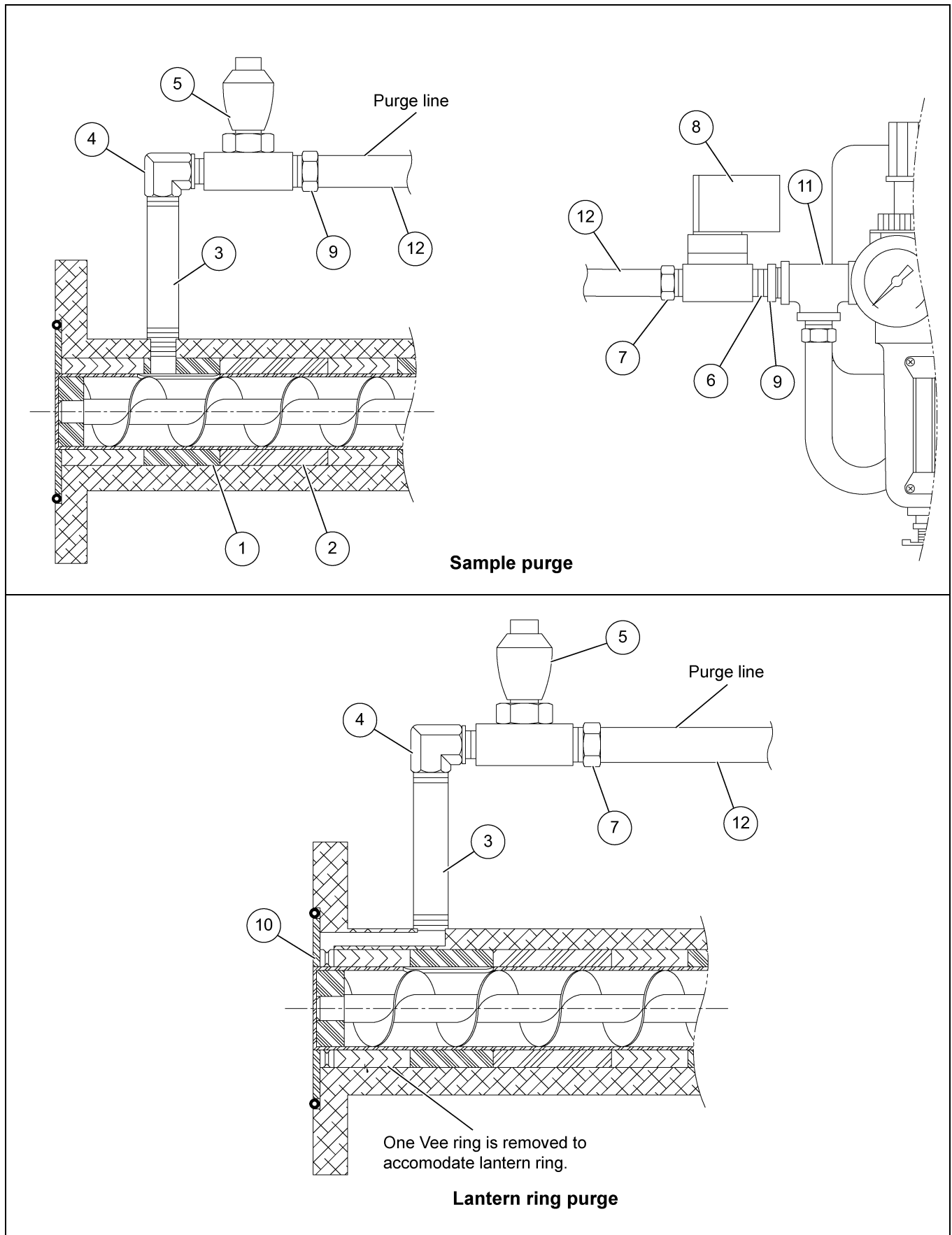

Figure 6C *Optional Purge Configurations*

Ref #	Part #	Description	Qty
1	513243	HD-PP-6 Front Seal Spacer Nylon	1
	524997*	HD-PP-6 Front Seal Spacer 316SS	1
	514079	HD-PP-8 Front Seal Spacer Nylon	1
	542998*	HD-PP-8 Front Seal Spacer 316SS	1
	513245	HD-PP-10 Front Seal Spacer Nylon	1
	524997*	HD-PP-10 Front Seal Spacer 316SS	1
	514079	HD-PP-12 Front Seal Spacer Nylon	1
	514998*	HD-PP-12 Front Seal Spacer 316SS	1
2		HD-PP-10 and 12 Samplers Only	
	518997	HD-PP Extra Seal Spacer Nylon	1
	524999*	HD-PP Extra Seal Spacer 316SS	1
3	34448	Brass Pipe Nipple 3/8" x 2-1/2" LG	1
4	34451	Brass 90° Street Elbow 3/8"	1
5	28194	3/8" Needle Valve	1
6	512823	Brass Pipe Close Nipple 3/8"	1
7	24553	3/8" Push-Loc to 3/8" MPT Street	2
8	515679	2-Way Solenoid Valve 3/8" NPT	1
	515877*	2-Way XP Solenoid Valve 3/8"	1
9	34435	Brass Pipe Bushing 1/2" to 3/8"	1
10		Lantern Ring 3" x 3"-3/4 x 5/16"	1
11	24565	Brass Pipe Tee 1/2" NPT	1
12	24550	3/8" I.D. Air Hose	4'

* **NOTE:** Refer to certified drawing(s) for specific options.

6. Operation and Adjustments

Air Filter/Pressure Regulator

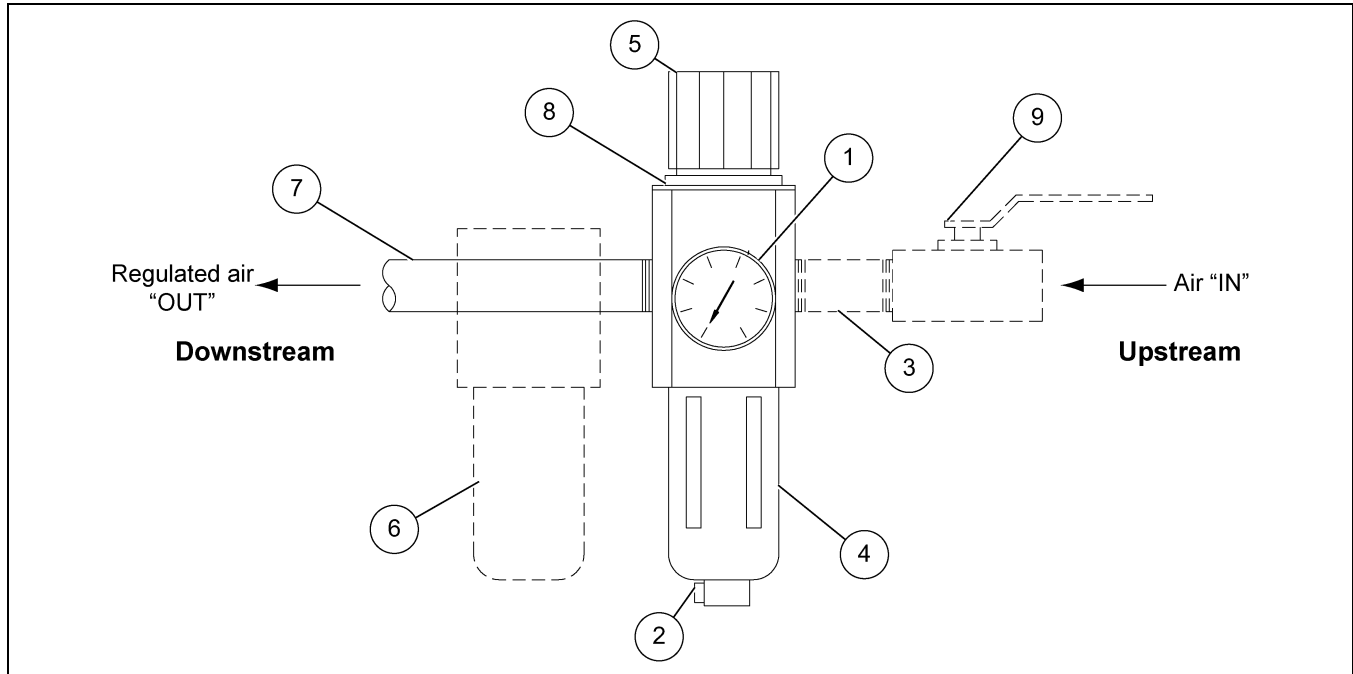

Figure 6D Filter/Regulator

Ref #	Description	Ref #	Description
1	Air Pressure Gauge	6	Lubricator (Optional by others field installed)
2	Filter Drain Valve	7	3/4" NPT Airline to Control Valves
3	3/4" Pipe (Minimum)	8	Pressure Regulator
4	Air Filter and Bowl Guard	9	Lockable, vented shut off valve required (by others field installed).
5	Adjustment Knob		

The air filter/regulator assembly provides a clean and regulated air supply to the samplers pneumatic components. A pressure gauge gives the operator an accurate reading of the downstream air pressure. The regulator is equipped with an adjustment knob for controlling the outlet pressure and a manual "pet-cock" type drain for draining the filter bowl.

Prior to introduction of air supply, turn the adjustment knob counterclockwise until all load is removed from the regulating spring. Turn ON system air pressure. Turn adjustment knob clockwise until desired outlet pressure is reached.

To avoid minor re-adjustments after making a change in the pressure setting, always approach the desired setting from a lower pressure. When reducing from a higher setting to a lower setting, first reduce to a pressure setting lower than desired and then adjust upward.

To "lock-in" the pressure setting on the regulator, push the lockring on the adjustment knob down until it snaps into place. To release pull the lockring upward. The pressure setting can be made tamper resistant by installing a seal wire in the groove above the lockring.

Pneumatic Cylinder

This double-acting air cylinder extends and retracts the sample probe. Stroke length varies with the sample probe stroke. The cylinder rod is connected to the sample probe by means of the threaded probe adjustment rods. Solenoid valve V-1 controls extension and retraction of the cylinder.



Failure to observe all safety rules, written and implied and those suggested by common sense, can result in death, serious injury and/or equipment damage. Lock out power before performing any maintenance.

General Maintenance

A good maintenance program involves thorough general housekeeping, adequate periodic re-lubrication, and replacement of worn or damaged components.

Periodic Inspection

At regularly scheduled intervals, while observing all safety precautions, observe the sampler as it operates. Inspect for:

1. Loose or missing hardware
2. Noisy motor or motor/reducer bearings
3. Overheated motor or reducer
4. Adequate lubricant in lubricator and gear reducer
5. Structural damage
6. Rust or corrosion
7. Damaged wiring and conduit, exposed conductors and connections
8. Damaged airlines or pneumatic components
9. Make sure that all guards are in place and that all warning labels are in place and legible.
See Page 8, GENERAL SAFETY INFORMATION, explains the purpose and intended location of the warning signs. Warning signs are an important part of any safety program; replace any missing signs IMMEDIATELY.

Lubrication

Auger Bevel Gears

The auger bevel gears are designed to run dry. If grease is applied to the gears, extra care must be taken to ensure that the grease remains free from contaminants.

Airline Lubricator

An airline lubricator is not required. The cylinder is of a non-lube design requiring NO lubrication. If the use of a lubricator is desired, it must be field mounted between the F/R and the directional control valve. If a lubricator has been added to the system, the user must determine the appropriate lubricant and the proper intervals for refilling the reservoir. Refer to the lubricator manufacturer's technical literature. Note that by introducing oil into the airline, it will be discharged into the surrounding environment near the air exhausts of the directional control valve(s) on the sampler.

Draining and Servicing the Filter



Escape of pressurized air, fluids, and contaminants at high velocity can cause injury to unprotected eyes. Always wear eye protection when draining a filter.

Drain the accumulated fluid whenever the fluid level in the reservoir (quiet-zone) rises to the lower baffle. Filters have either a screw-type drain or a push-type drain. If the filter requires frequent draining, consider installing an automatic drain or an air drying system. Periodically, the bowl may need to be removed to clean out accumulated moisture and contaminants.

1. Shut off and lock out the air supply.
2. Operate a valve or loosen an airline connection to relieve all pressure downstream from the filter/regulator.
3. Remove and clean the bowl; various types of clamp rings or threaded collars are used to retain bowls.

NOTE: *The bowls of filter/regulators can not be removed while pressurized. Internal pressure prevents the clamp ring or threaded collar from turning.*

4. Clean or replace the filter element.
5. If the bowl seal is damaged or brittle replace it. In any event lightly coat the seal with petroleum-based grease to help hold it in position.
6. Re-install the bowl. Turn ON pressure and make sure the bowl is seated and sealed.

Mechanical Repair Procedures

Adjustment of Seal Pressure

A series of V-ring packing assemblies and spacers within the seal housing support and seal the sample tube. When the sampler has operated for an extended period of time, the seals may wear or extrude. If evidence of leaking from the conveying line along the sample tube is noticed, first try to increase the compressive force on the seal and spacer stack.

As shown on the section drawings of the samplers [on Pages 46-54](#), the V-ring packing seals are held compressed by the compression plate. Two 3/8"-16 UNC hex head screws clamp the plate to the rear flange of the seal housing. Using 9/16" wrenches evenly tighten the two cap screws a 1/2" turn at a time. This will compress the seal and spacer stack, increasing the seal effect on the sample tube.

NOTE: *Excessive compression on the seal and spacer stack will result in permanently deformed and ineffective seals that will have to be replaced. It is possible to over tighten the seal and spacer stack which can result in the seizure of the sample tube, rendering it incapable of extending or retracting.*

If the leak can not be stopped by adjusting seal pressure, then the seals will have to be replaced as explained in Seal Replacement section [on Page 35](#).

Seal Replacement

When following the instructions below, refer to the applicable drawing of the sampler. Refer to the drawings in [on Pages 46-54](#) and the certified drawing(s).

1. Shut off and lock out all power (electrical and pneumatic).
2. Shut down the conveying line and remove the sampler assembly. Install a properly designed cover plate over the hole in the conveying line. Save the gasket(s); if any have deteriorated or are damaged, order replacements.
3. In order to remove the seals, remove and retain the following components and save ALL fasteners:
 - a. Remove the top and bottom covers of the sampler.
 - b. Remove the four 1/4"-20 UNC hex head bolts attaching the side panels to the seal housing and the two 3/8"-16 UNC hex head bolts attaching the guide rods to the seal housing.
 - c. Remove the two 1/4"-20 UNC hex head compression plate screws.
 - d. Pull the seal housing off of the sample probe.
 - e. Remove the 1/4"-20 UNC hex head screws(s) over the discharge spacer and the front spacer.
 - f. Remove the four 1/4"-20 UNC flat head screws attaching the seal retainer to the seal housing.
 - g. Remove the seals and spacers taking care to avoid damaging the seal housing bore. Use a 3-1/2" diameter round plastic bar or wooden dowel to push with, if necessary.
 - h. Replace worn items and clean the remaining components. Remove any burrs or scratches from the bore of the seal housing.
4. Rebuild the sampler in the following order.
 - a. Re-install the seal retainer plate using the four 1/4"-20 UNC flat head screws.
 - b. Refer to the Teflon Seal Spacer Arrangement is shown in [Figure 9A on Page 44](#). It illustrates the order of insertion and orientation of seals and spacers. Carefully insert the seals and spacers from the rear of the seal housing, pushing them towards the front.
 - c. Re-install the 1/4"-20 UNC hex head screw(s) over the discharge spacer and the front spacer.
 - d. Position the compression plate so that it bears on the end of the rear spacer. Loosely re-install the two 3/8"-16 UNC hex head screws and nuts which clamp the plate to the seal housing flange.
 - e. Carefully slide the seal housing over the sample tube and into position.
 - f. Re-install the four 5/16"-18 UNC hex head bolts fastening the side plates to the seal housing. Install the four 1/2"-13 UNC hex head bolts fastening the guide rod to the seal housing. Make certain that the seal housing is aligned with the sample tube so there is no side thrust. Then securely tighten all the screws.
 - g. Evenly tighten the compression plate screws to firmly compress the seal and spacer stack.
5. Remove the cover plate on the sample conveying line and reattach the sampler.

7. Maintenance and Repair

6. Restore power to the sampler and operate it through several collection cycles. If air leaks along the sample tube are detected, tighten both compression plate screws 1/2" turn. Make sure compression plate flange remains parallel to the seal housing flange. Repeat the process until no leakage is detected.
7. Re-install the top and bottom covers of the sampler.

Sample Probe, Auger and Seal Replacement

When following the instructions below refer to the applicable drawing of the sampler. Refer to the drawings [on Pages 46-54](#) and the certified drawing(s).

1. Follow instructions in Seal Replacement section [on Page 35](#) "1" through "3".
2. Disconnect the sample probe from the air cylinder assembly by removing the two 3/4" hex head nuts on the threaded adjustment rods.
3. Remove the two 1/4"-20 UNC hex head lock nuts and bolts that fasten auger bearing housing to the sample probe. Pull the sample probe off the auger and the auger bearing housing.
4. Loosen the two set screws on the 28 tooth bevel gear and remove from the auger shaft.
5. Use a fine file or emery paper to remove any screw burrs from the end of the auger shaft.
6. Remove the auger from the bearing housing. Be sure to save the thrust washers on the auger shaft.
7. Clean and inspect any items to be reused. Replace any worn or damaged parts.
8. Re-assemble the auger, thrust washer, auger bearing housing, thrust washer and 28 tooth bevel gear. Keeping the assembly tight, align one of the gear set screws directly over the flat spot on the auger shaft and tighten both set screws.
9. Carefully slide the auger and bearing housing assembly back into the sample probe. Make sure that the front shaft of the auger slips into the auger end bearing located inside the capped end of the sample probe.
10. Align the holes in the sample probe and the auger bearing housing. Re-install and tighten the 1/4"-20 UNC hex head bolts with lock nuts.
11. Re-assemble the sample probe to the air cylinder assembly by replacing the two 1/2"-13 UNC hex head nuts on the threaded adjustment rods. Make sure the air cylinder is fully retracted and check for proper meshing of the gears; there must be full depth engagement of the gear teeth, but no bending of the gearmotor shaft.

NOTE: *If the gear teeth do not mesh properly, the gears will wear rapidly.*

12. Continue by following instructions in Seal Replacement section [on Page 35](#) "4" through "7".

Bevel Gears Replacement

When following the instructions below refer to the applicable drawing of the sampler. Refer to the drawings [on Pages 46-54](#) and the certified drawing(s).

NOTE: *Always replace bevel gears in sets. Replacing a single gear is a false economy as the new gear will wear immediately.*

1. Shut off and lock out all power (electrical and pneumatic).
2. Shut down conveying line and remove the sampler assembly. Install a properly designed cover plate over the hole in the conveying line. Save the gasket(s); if any have deteriorated or are damaged, order replacements.
3. Remove the top and bottom covers of the sampler.
4. Remove the four 5/16"-18 UNC hex head bolts attaching the motor side panel to the seal housing and cylinder mount plate.
5. Loosen the two set screws in the 28 tooth bevel gear and slip it off the gearmotor shaft. Leave the gear spacer on the shaft unless it requires replacement. Save the shaft key.
6. Install the new 28 tooth bevel gear on the gearmotor shaft. (It should be tight against the spacer.) Make sure the shaft key is in place and tighten the set screws.
7. Disconnect the sample probe from the air cylinder assembly by removing the two 1/2"-13 UNC hex head nuts on the threaded adjustment rods.
8. Extend the sample probe into the seal housing by pushing on the end of the probe.
9. Loosen the two set screws in the 28 tooth bevel gear and slip it off the auger shaft. Leave the thrust washer on the shaft unless it requires replacement.
10. Install the new 28 tooth bevel gear on the auger shaft (make sure the thrust washer is in place). Insert a wooden stick or soft metal bar into the sample slot opening and push the auger tight against the auger bearing housing. Keeping the assembly tight, align one of the gear set screws directly over the flat spot on the auger shaft and tighten both set screws.
11. Replace the motor side panel assembly. Re-install the four 5/16"-18 UNC hex head bolts and tighten.
12. Retract the sample probe into the seal housing by pushing on the end of the probe. Reconnect the sample probe to the air cylinder assembly by replacing the two 1/2"-13 UNC hex head nuts on the threaded adjustment rods. Make sure the air cylinder is fully retracted and check for proper meshing of the gears; there must be full depth engagement of the gear teeth, but no bending of the gearmotor shaft.

NOTE: *If the gear teeth do not mesh properly, the gears will wear rapidly.*

13. Remove the cover plate on the sample conveying line and reattach the sampler.
14. Restore power to the sampler and operate it through several collection cycles. If air leaks along the sample tube are detected, tighten both compression plate screws 1/2" turn. (Making sure compression plate flange remains parallel to the seal housing flange.) Repeat the process until no leakage is detected.
15. Re-install the top and bottom covers of the sampler.

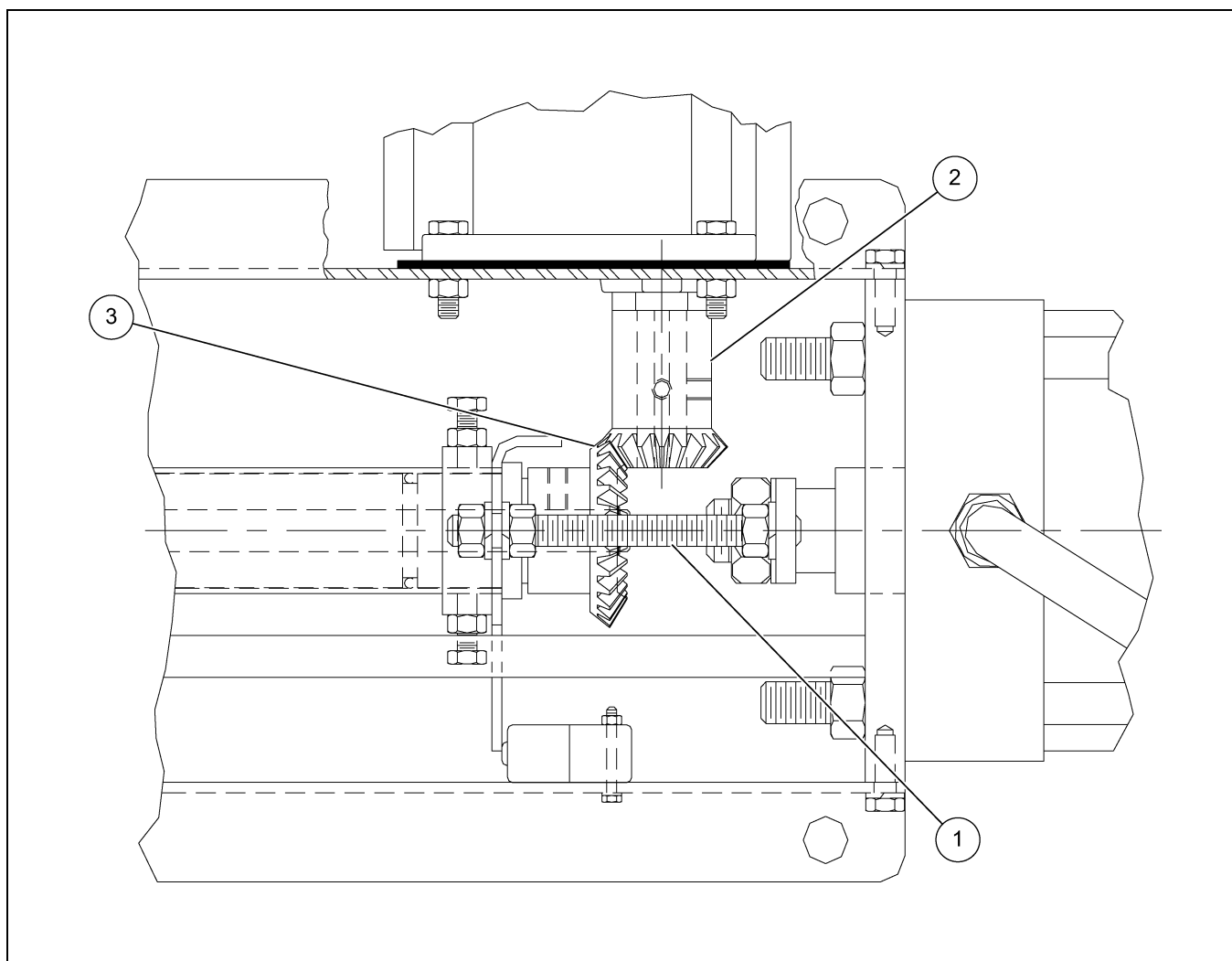

Figure 7A *Bevel Gear Alignment*

Ref #	Description
1	Adjustment rods for setting proper gear mesh.
2	Gear motor shaft must not deflect when gears mesh as the air cylinder retracts while under pressure.
3	Gears must fully mesh for long life.

General HD-PP Sampler Troubleshooting



Careless or accidental restoration of power can result in death or serious injury. Make certain area is clear before removing lock outs.

Problem	Possible Cause	Corrective Action
Sampler does not cycle in either Auto or Manual modes (Power light OFF).	Power switch OFF.	Turn power switch ON.
	Circuit breaker is open.	Reset breaker.
	Main fuse is blown. (FU1)	Replace fuse. Refer to Main Fuse (FU1) section on Page 26 .
	Faulty supply wiring.	Correct. Refer to certified electrical schematic.
	Defective power switch.	Replace switch.
Sampler does not cycle in either Auto or Manual modes (Power light ON).	Faulty system wiring.	Correct. Refer to certified electrical schematic.
	No or low air pressure.	Turn ON air supply and set regulator to 80-100 PSI.
	Defective control valve.	Refer to Directional Solenoid Valve Troubleshooting section on Page 41 .
Sampler cycles in Manual mode, but not in Automatic mode.	Automatic initiate jumper not installed.	Install jumper across terminals 1 and 2.
Sample size too small or large.	Solenoid time on setting too low or high.	Adjust time settings. Refer to Manual PNEG-2170.
Sampler sluggish. (Operates too slowly).	Inadequate air supply.	Increase line size or add surge tank.
	Regulator set too low.	Reset. Refer to Air Filter/Pressure Regulator Section on Page 32 .
	Filter clogged.	Clean as outlined in Draining and Servicing the Filter section on Page 34 .
	Airline from filter regulator blocked or damaged.	Inspect and correct.
	Cylinder seal leakage.	Refer to Cylinder Leaking section on Page 42 .
Auger bevel gears wear rapidly.	Gears are not meshing properly.	Adjust. Refer to Bevel Gears Replacement section on Page 37 .
	Sample container over filling and material is backing up into the sampler.	Empty sample container promptly or incorporate a sensor to shut off the sampler when the container is full.
	Limit switch LS-1 not wired properly or defective.	Inspect. Refer to Limit Switch section on Page 28 .
	Large air pressure drop during sampling cycle.	Increase air supply line size. Refer to System Piping section on Page 23 and Compressed Air Consumption section on Page 24 .
Sampler makes loud banging noise when probe retracts.	Gears are rotating after disengagement.	Make sure motor is coming to a complete stop before taking another sample.

8. Troubleshooting

Problem	Possible Cause	Corrective Action
Sampler leaks air or material continuously out the sample discharge.	Packing seals not tight.	Tighten. Refer to Adjustment of Seal Pressure section on Page 34 .
	Packing seals worn out.	Inspect and replace. Refer to Seal Replacement section on Page 35 .
	Sample probe worn out.	Inspect and replace. Refer to Sample Probe, Auger and Seal Replacement section on Page 36 .
Auger motor runs when probes extends.	Control program Mode improperly set.	Set Mode to "0". Refer to Manual PNEG-2170
	Limit switch LS-1 not wired properly or defective.	Inspect. Refer to Limit Switch section on Page 28 .
Auger motor does not run (Probe extends and retracts).	Motor not wired properly.	Correct. Refer to certified electrical schematic.
	Defective motor.	Replace.
	Defective control relay.	Replace.
Sample probe does not extend or retract.	No or low air pressure.	Turn ON air supply and set regulator to 80-100 PSI.
	Defective control valve.	Refer to Directional Solenoid Valve Troubleshooting on Page 41 .
	Material caked up in seals.	Inspect and replace. Refer to Seal Replacement section on Page 35 .
	Defective air cylinder seals.	Inspect and replace. Refer to Cylinder Leaking section on Page 42 .
	Sample probe bent or jammed.	Inspect and replace. Refer to Sample Probe, Auger and Seal Replacement section on Page 36 .

PC Board Troubleshooting

Problem	Possible Cause	Corrective Action
Motor fuse blows continuously.	Motor wired improperly.	Correct. Refer to the certified electrical schematic.
	Motor jammed.	Inspect and replace.
	Auger seized up in sampler.	Inspect and replace. Refer to Sample Probe, Auger and Seal Replacement section on Page 36 .
	Defective control component	Inspect and replace.
Sampler probe extends and retracts but motor does not run. (control resets).	Low voltage power supply.	107 VAC minimum for 110/120 VAC. 215 VAC minimum for 220/240 VAC.
	Inadequate power supply wiring.	Monitor voltage when motor starts. It should not drop below 107 VAC, or 215 VAC.

NOTE: HD-PP samplers require the program mode to be set to "0" (zero). Refer to the control manual PNEG-2170.

Directional Solenoid Valve Troubleshooting

Problem	Possible Cause	Corrective Action
Valve does not shift.	No or low air pressure.	Turn ON air supply and set regulator to 80-100 PSI.
	Faulty field wiring.	Check for full line voltage at the solenoid.
	Solenoid coil burnt out.	Replace coil if no continuity through coil.
	Valve clogged or stuck.	Remove and clean. Or replace.
	Defective CR1 Relay.	Replace.
Valve leaks air continuously out an exhaust port.	Defective valve seals.	Refer to Valve vs. Cylinder Leak Test Section on Page 43 .
	Defective cylinder seals.	Refer to Valve vs. Cylinder Leak Test Section on Page 43 .

There must be at least 80 PSI pressure at the valve. The valve pilot operators are air assisted. If there is insufficient pressure the valve will not shift or may not shift completely.

Observe the pressure gauge. Assume the gauge indicates sufficient pressure when the sampler is idle, 85 PSI for example. If the pressure drops significantly to perhaps 55 PSI when the valve shifts, a blocked or damaged air line should be suspected.

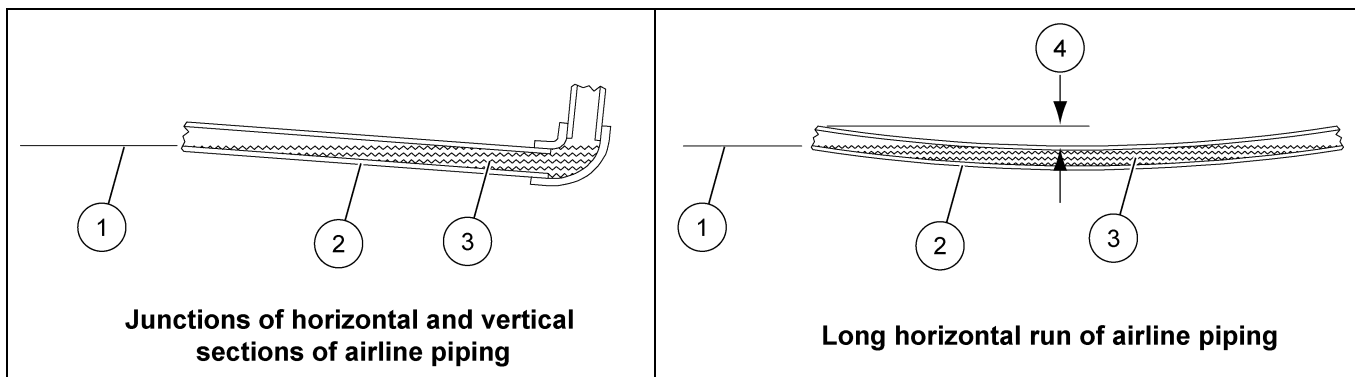

Figure 8A *Condensed Moisture Blocking Airline*

Ref #	Description
1	Water Level
2	Airline
3	Condensed Moisture
4	Sag of Pipe Greater than Internal Diameter

8. Troubleshooting

One often overlooked cause of insufficient air flow is moisture condensing and collecting in a low spot in the supply line. *Figure 8A on Page 41* illustrates an exaggerated example of such a problem. It can be seen that if the pipe sags only slightly over a long distance and water collects in the low spot over an extended period of time, the airline could be partially or completely blocked. A similar condition often occurs where there is a junction of horizontal and vertical sections of an air line.

This problem is particularly prevalent when there is high ambient humidity and the equipment operates infrequently and intermittently, as in the case of a sampler.

NOTE: *All horizontal runs of an airline should have a moisture trap and the traps should be drained frequently; at least once a day; especially, when humidity levels are high.*

Air Components Troubleshooting

Cylinder Leaking

1. External Leakage

- a. Rod seal leakage can generally be traced to worn or damaged seals. Examine the piston rod for wear or damage. Replace the rod and seals if the rod's surface is rough or worn out-of-round.
- b. Soft or gummy seals are evidence of incompatibility with some substance in the air supply. Evaluate the area where the air intake is located. If an airline lubricator is included in the system, check to see if the lubricant being used is compatible with the seal material.

2. Internal Leakage

- a. The lipseal piston seals are virtually leak free unless they are worn or damaged. Replace defective seals.
- b. Contaminants in the air supply can lead to scored cylinder walls, resulting in rapid seal wear. If such is the case, check to see if the filter is being drained frequently. A different type of filter may be required; one that can remove finer particles or one that can filter out different kinds of contaminants.
- c. Possible piston cylinder leakage, apparently indicated by piston drift is not always traceable to the piston. A leak through a closed valve port can also cause piston drift.

To determine if the cylinder piston is leaking (cylinder is bypassing), remove the cylinder retract hose from port "4" of the valve. This is the hose from the nose (piston rod) end of the cylinder. Use the valve's manual override to extend the cylinder. When the cylinder is fully extended, if air leaks from the retract port hose, the cylinder is bypassing. The cylinder will need to be repaired or replaced.

Valve vs. Cylinder Leak Test

When there is continuous leakage out of a valve exhaust port, proceed as follows to determine if the leak is caused by defective valve seals or by defective cylinder seals.

1. Cylinder retracted as shown *Detail 1* in *Figure 8B*.
 - a. If there is continuous leakage out of Port “5”, the valve seals are defective and must be replaced.
 - b. If there is continuous leakage out of Port “3”, the problem can be with the valve seals or the cylinder seals. To determine which proceed as follows:
 - i. Disconnect the line between Valve Cylinder Port “2” and the cylinder per *Detail 2* in *Figure 8B*.
 - ii. If leakage continues out of Port “3” and/or Cylinder Port “2”, the valve seals are defective and must be replaced.
 - iii. If there is a leakage out of the line from the cylinder, the cylinder seals are defective and must be replaced.
2. Cylinder extended as shown *Detail 3* in *Figure 8B*.
 - a. If there is continuous leakage out of Port “3”, the valve seals are defective and must be replaced.
 - b. If there is continuous leakage out of Port “5”, the problem can be either the valve seals or the cylinder seals. To determine which proceed as follows:
 - i. Disconnect the line between Valve Cylinder Port “4”, and the cylinder per *Detail 4* in *Figure 8B*.
 - ii. If leakage continues out of Port “5” and/or Cylinder Port “4”, the valve seals are defective and must be replaced.
 - iii. If there is a leakage out of the line from the cylinder, the cylinder seals are defective and must be replaced.

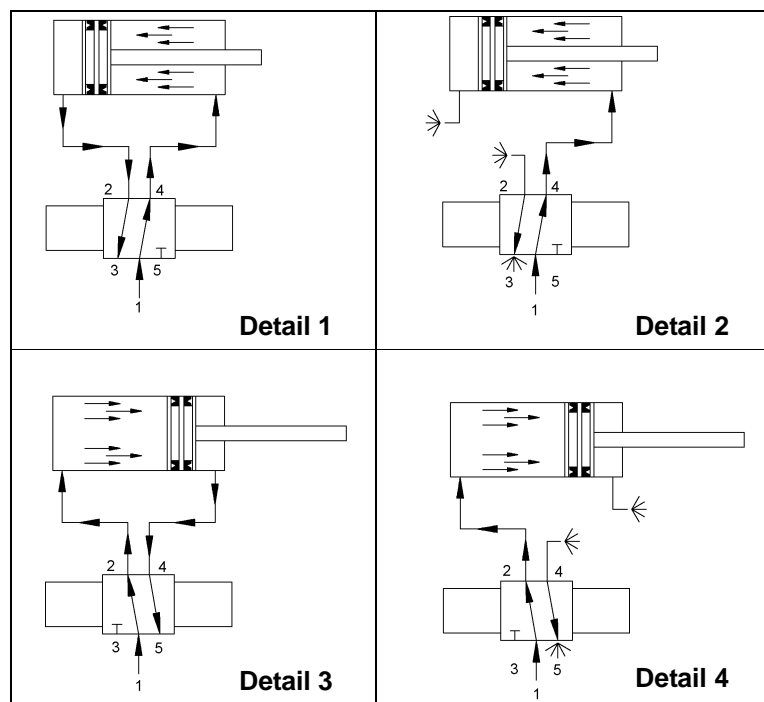

Figure 8B Valve Vs. Cylinder Leak Test Diagram

9. Teflon and Purge Configurations

Teflon Seal Spacer Arrangements (6" and 8" Strokes)

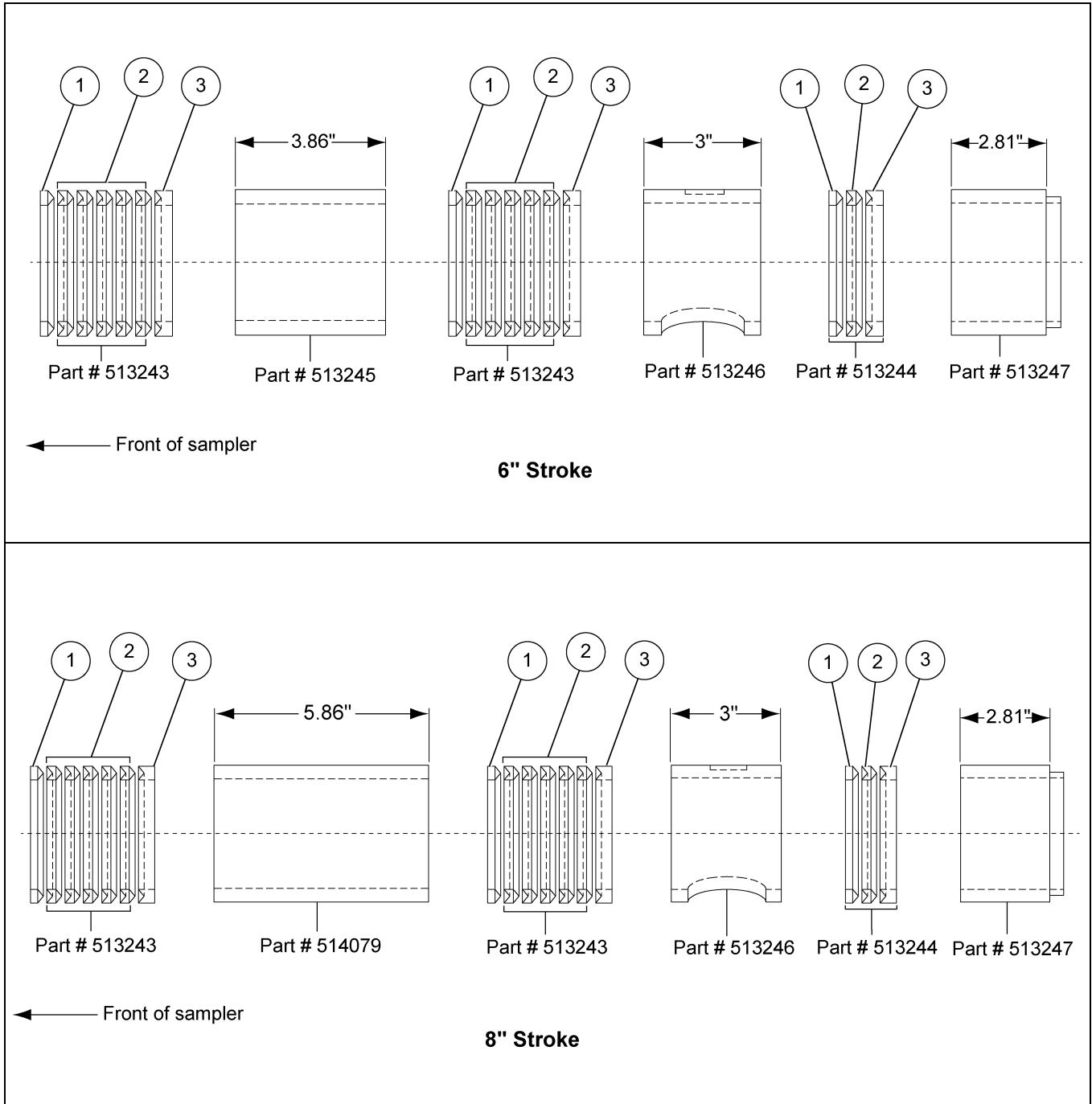

Figure 9A Teflon Seal Spacer Arrangements (6" and 8" Strokes)

Ref #	Description
1	Male Ring
2	Center Ring
3	Female Ring

Teflon Seal Spacer Arrangements (10" and 12" Strokes)

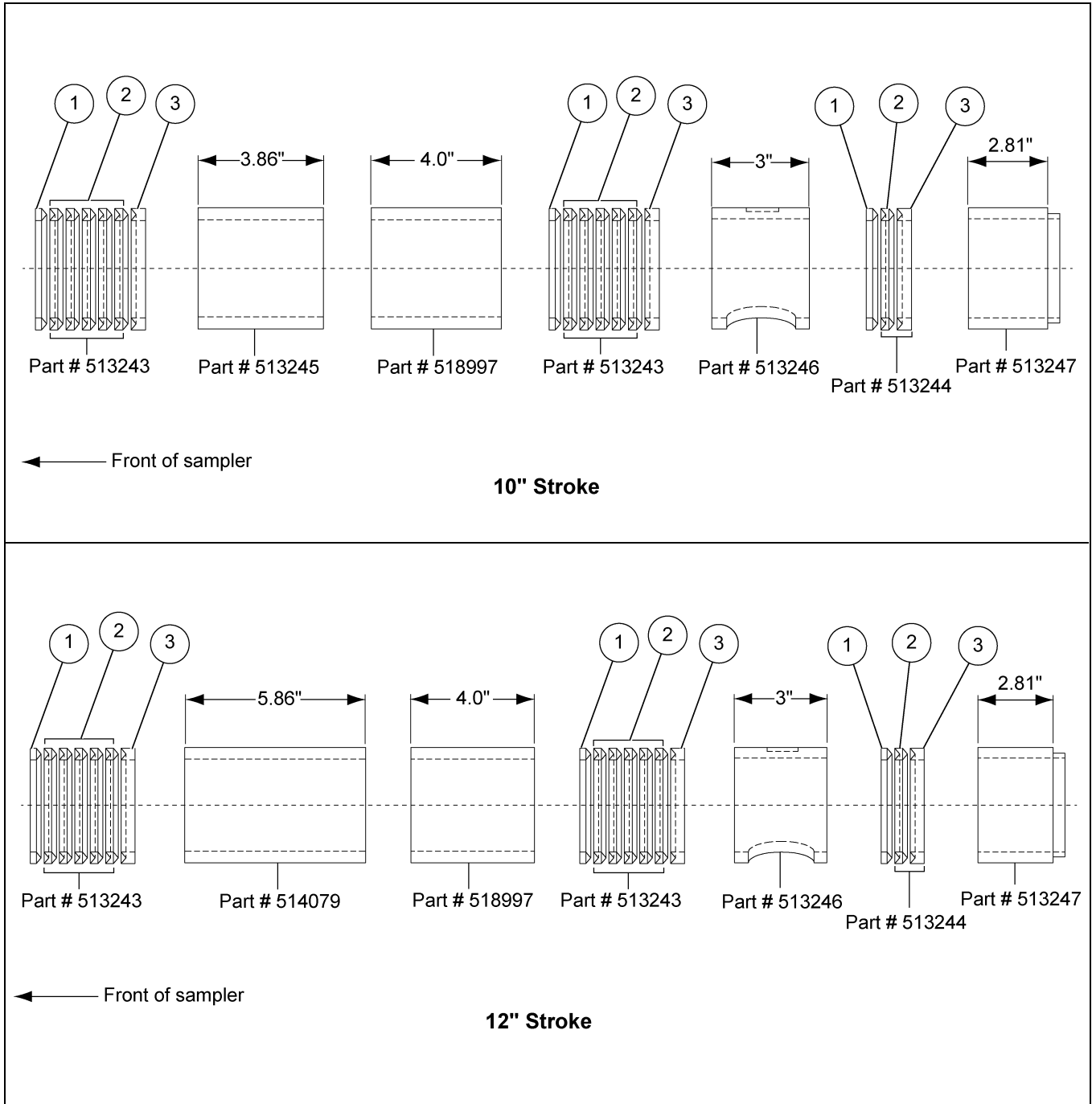
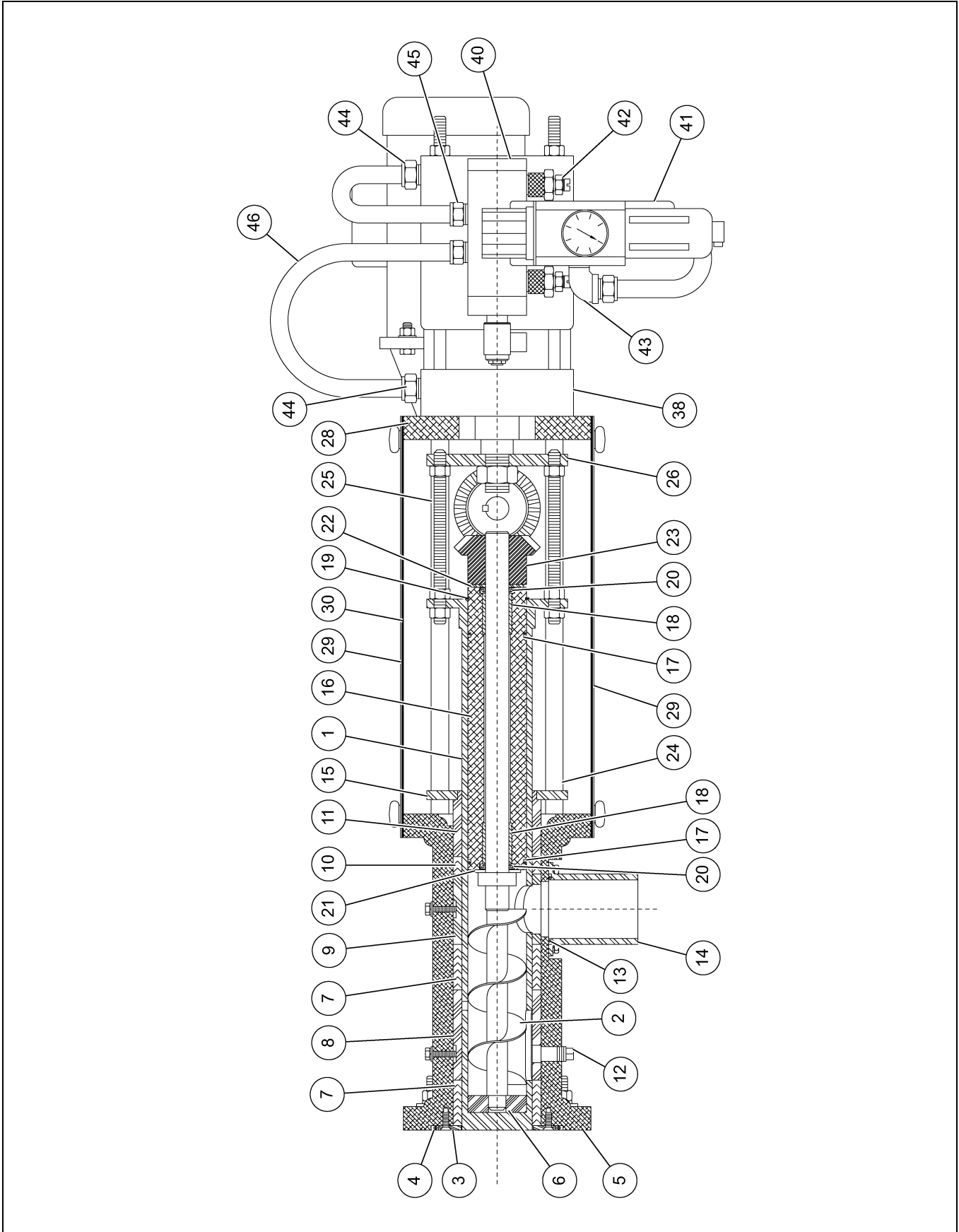

Figure 9B Teflon Seal Spacer Arrangements (10" and 12" Strokes)

Ref #	Description
1	Male Ring
2	Center Ring
3	Female Ring

HD-PP-6 Samplers 6" Stroke (525004)



HD-PP-6 Samplers 6" Stroke (525004) Parts List

Ref #	Part #	Description	Qty	Ref #	Part #	Description	Qty
1	516078*	HD-PP-6 Probe Down Flow	1	17	513238	O-Ring 2-1/4" x 2-1/2" BUNA N	2
	516079*	HD-PP-6 Probe Up Flow 316SS	1	18	513257	Bushing Bronze 1" I.D. x 1-3/4" LG	2
	516080*	HD-PP-6 Probe Left to Right	1	19	513252	Retaining Ring 2-1/2" Shaft SS	1
	516081*	HD-PP-6 Probe Right to Left	1	20	523259	Lip Seal 1.00" I.D. x 1-1/2" O.D. x 1/4" VITON	2
	524165*	HD-PP-6 Probe Down Flow Nedox	1	21	524356	Thrust Washer Nylon 1" I.D. HD-PP	1
	524166*	HD-PP-6 Probe Up Flow Nedox	1	22	513880	Washer Thrust 1" I.D. 2.0" O.D. 0.13" Thick	1
	524167*	HD-PP-6 Probe L to R Flow Nedox	1	23	513253	Gear Miter 28T 8 D.P.	2
	524168*	HD-PP-6 Probe R to L Flow Nedox	1	24	513241	Guide Rod SS HD-PP-6	4
2	513235	HD-PP-6 Auger 316SS (Standard)	1	25	513259	Probe Adjustment Rod HD-PP	2
	524153*	HD-PP-6 Auger 316SS Nedox Coated	1	26	513240	HD-PP Cylinder Guide Plate	1
3	513248	Seal Retainer SS HD-PP	1	27	513251	HD-PP Drive Gear Spacer	1
4	513289	O-Ring 5" x 5-1/2" BUNA N	1	28	513233	HD-PP Cylinder Mount Plate 6 Bore	1
5	516075*	Seal Housing Down Flow	1	29	513234	HD-PP-6 Cover Plate	2
	513230*	Seal Housing Up Flow	1	30	34355	Seal Dortite 1/8" Thick 1/2" W	20'
	516076*	Seal Housing Left to Right Flow	1	31	513249	HD-PP-6 Motor Side Plate	1
	516077*	HS-PP-6 Seal Housing R to L Flow	1	32	513250	HD-PP-6 Limit Switch Side Cover	1
6	520370	Auger End Bearing HD-PP	1	33	513232	HD-PP Drive Shaft	1
7	513243	CVH Seal Set 3" x 3-1/4" x 1.947"	2	34	513115	Reducer Gear 30:1 Ratio Falk	1
8	513245	HD-PP Front Seal Spacer 3.856L	1	35	26242	Motor 1/2 HP 1 PH TEFC 56C	1
8	524997*	Front Seal Spacer 316SS	1	36	26402	Switch Limit Nema 4 12	1
9	513246	Middle Seal Spacer HD-PP	1	37	35341	Switch Limit Arm Roller Adjustment	1
	525020*	Seal Spacer HD-PP Discharge 316SS 3.00 LG	1	38	513287	Cylinder Air 6 B x 6 STK 2MA	1
10	513244	CVH Seal Set 3" x 3-1/4" x 0.747"	1	39	514075	Air Valve Mount Bracket	1
11	513247	Seal Spacer Rear HD-PP	1	40	543184	Valve Air 3/8" NPT 120 VAC 2 Position 4 Way	1
	525021*	Seal Spacer HD-PP Rear 316SS 2.81LG	1	41	543180	Filter Regulator Assembly 3/8" NPT 125 PSI	1
12	34432	Pipe Plug 3/8" NPT Brass	1	42	34044	Speed Control 3/8" NPT Adjustment BRAS	2
13	27240	O-Ring 2-5/8" x 2-7/8" FDA	1	43	513290	Pipe Street Elbow 1/2" NPT 90°	1
14	513237	HD-PP Discharge Tube 3.00" O.D.	1	44	513288	Fit Air Push-Loc 1/2" x 3/4" MPT Street	2
15	513242	HD-PP Seal Compression Plate	1	45	24558	Fit Air Push-Loc 1/2" x 1/2" MPT Street	4
16	513239	Bearing Housing With Seals HD-PP-6	1	46	36636	Hose Air 1/2" I.D. Push-Loc	5'

* **NOTE:** Refer to certified drawing(s) for specific options.

NOTE: Refer to motor configuration drawing on [Page 54](#) for continuation of complete part listing.

HD-PP-8 Samplers 8" Stroke (525005)

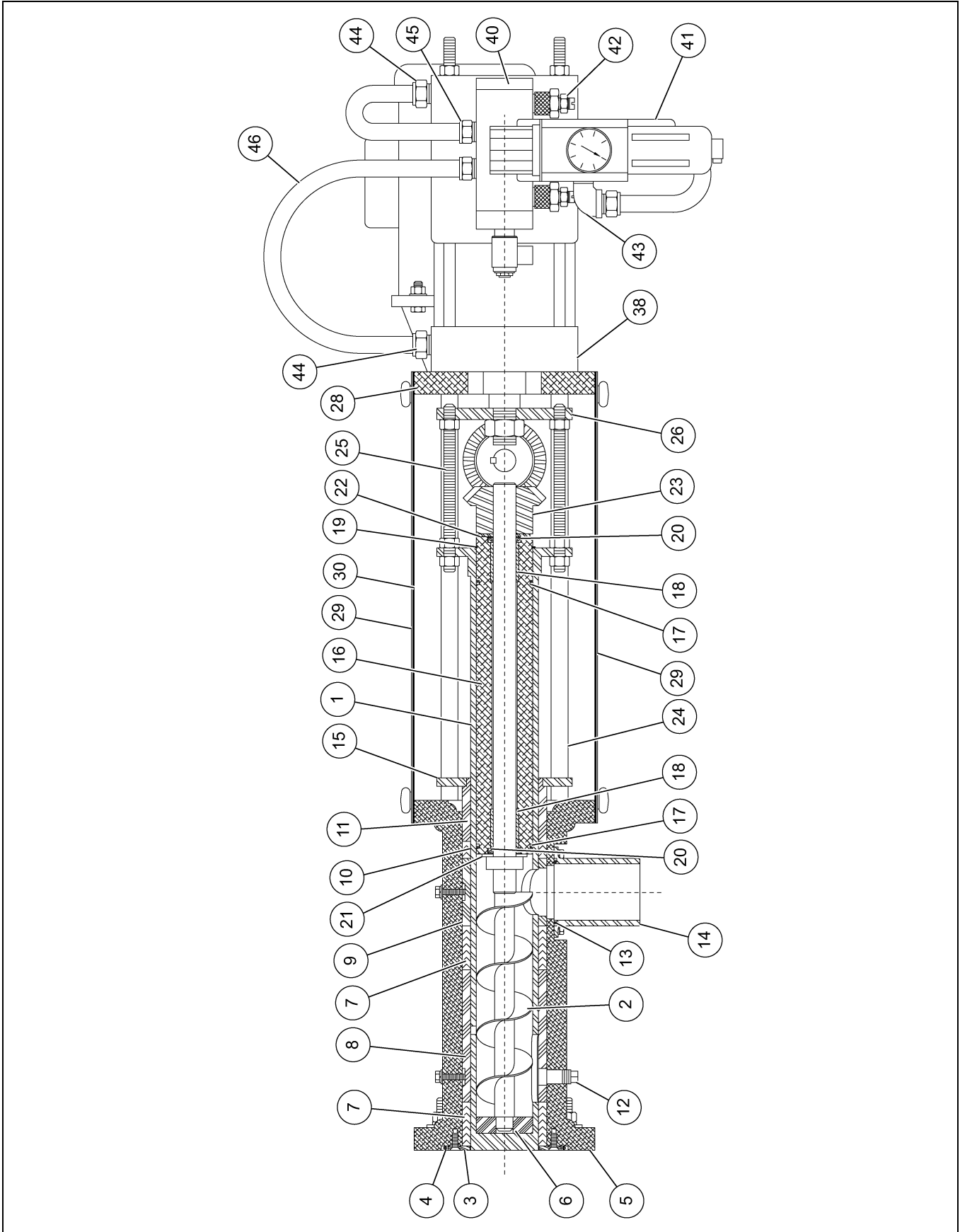

HHD-PP-8 Samplers 8" Stroke (525005) Parts List

Ref #	Part #	Description	Qty	Ref #	Part #	Description	Qty
1	516722*	HD-PP-8 Probe Down Flow 316SS	1	17	513238	O-Ring 2-1/4" x 2-1/2" BUNA N	2
	516723*	HD-PP-8 Probe Up Flow 316SS	1	18	513257	Bushing Bronze 1" I.D. x 1-3/4" LG	2
	516724*	HD-PP-8 Probe L to R Flow 316SS	1	19	513252	Retaining Ring 2-1/2" Shaft SS	1
	516725*	HD-PP-8 Probe R to L Flow 316SS	1	20	523259	Lip Seal 1.00" I.D. x 1-1/2" O.D. x 1/4" VITON	2
	524169*	HD-PP-8 Probe Down Flow Nedox	1	21	524356	Thrust Washer Nylon 1" I.D. HD-PP	1
	524170*	HD-PP-8 Probe Up Flow Nedox	1	22	513880	Washer Thrust 1" I.D. 2.0" O.D. 0.13" Thick	1
	524171*	HD-PP-8 Probe L to R Flow Nedox	1	23	513253	Gear Miter 28T 8 D.P.	2
	524172*	HD-PP-8 Probe R to L Flow Nedox	1	24	514078	Guide Rod	4
2	514392	HD-PP-8 Auger Purchased	1	25	513259	Probe Adjustment Rod HD-PP	2
	524154*	HD-PP-8 Auger 316SS Nedox Coated	1	26	513240	HD-PP Cylinder Guide Plate	1
3	513248	Seal Retainer SS HD-PP	1	27	513251	HD-PP Drive Gear Spacer	1
4	513289	O-Ring 5" x 5-1/2" BUNA N	1	28	513233	HD-PP Cylinder Mount Plate 6 Bore	1
5	516693*	Seal Housing Down Flow	1	29	514076	Cover Plate Top and Bottom	2
	516694*	Seal Housing Up Flow	1	30	34355	Seal Dortite 1/8" Thick 1/2" W	20'
	516695*	Seal Housing Left to Right Flow	1	31	514080	Motor Side Plate	1
	516696*	Seal Housing Right to Left Flow	1	32	514081	Limit Switch Side Plate	1
6	520370	Auger End Bearing HD-PP	1	33	513232	HD-PP Drive Shaft	1
7	513243	CVH Seal Set 3" x 3-1/4" x 1.947"	2	34	513115	Reducer Gear 30:1 Ratio Falk	1
8	514079	HD-PP Front Seal Spacer 5.86 LG	1	35	26242	Motor 1/2 HP 1 PH TEFC 56C	1
	524998*	HD-PP Front Spacer 316SS 5.856 LG	1	36	26402	Switch Limit Nema 4 12	1
9	513246	Middle Seal Spacer HD-PP	1	37	35341	Switch Limit Arm Roller Adjustment	1
	525020*	Middle Seal Spacer 316SS	1	38	514082	Air Cylinder (6" Bore)	1
10	513244	CVH Seal Set 3" x 3-1/4" x 0.747"	1	39	514075	Air Valve Mount Bracket	1
11	513247	Seal Spacer Rear HD-PP	1	40	543184	Valve Air 3/8" NPT 120 VAC 2 Position 4 Way	1
	525021*	Seal Spacer HD-PP Rear 316SS 2.81 LG	1	41	543180	Filter Regulator Assembly 3/8" NPT 125 PSI	1
12	34432	Pipe Plug 3/8" NPT Brass	1	42	34044	Speed Control 3/8" NPT Adjustment BRAS	2
13	27240	O-Ring 2-5/8" x 2-7/8" FDA	1	43	513290	Pipe Street Elbow 1/2" NPT 90°	1
14	513237	HD-PP Discharge Tube 3.00" O.D.	1	44	513288	Fit Air Push-Loc 1/2" x 3/4" MPT Street	2
15	513242	HD-PP Seal Compression Plate	1	45	24558	Fit Air Push-Loc 1/2" x 1/2" MPT Street	4
16	514077	Bearing Housing with Seals HD-PP-8	1	46	36636	Hose Air 1/2" I.D. Push-Loc	5'

* **NOTE:** Refer to certified drawing(s) for specific options.

NOTE: Refer to motor configuration drawing on [Page 54](#) for continuation of complete part listing.

HD-PP-10 Samplers 10" Stroke (525006)

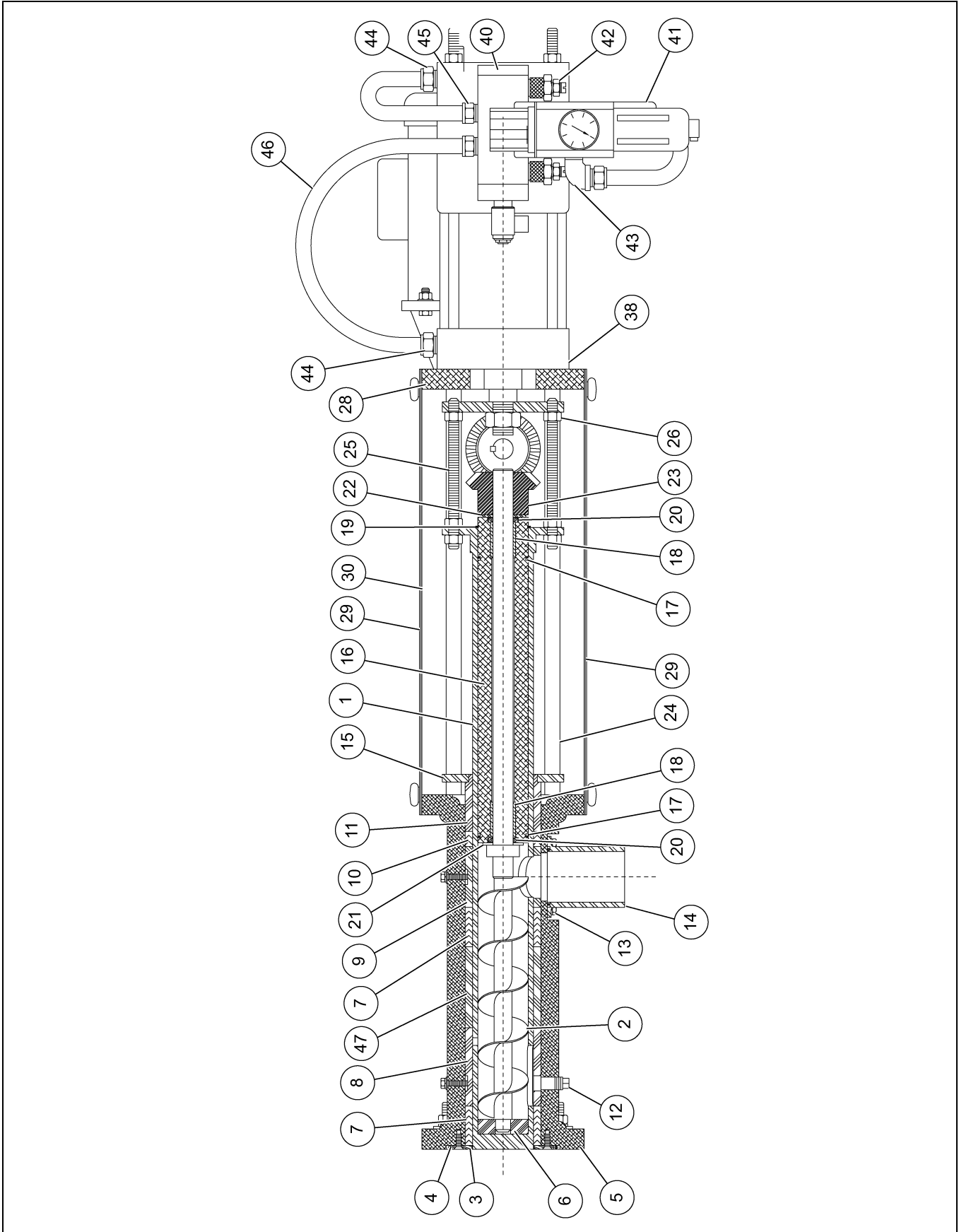

HD-PP-10 Samplers 10" Stroke (525006) Parts List

Ref #	Part #	Description	Qty	Ref #	Part #	Description	Qty
1	516726	HD-PP-10 Probe Down Flow 316SS	1	18	513257	Bushing Bronze 1" I.D. x 1-3/4" LG	2
	516727	HD-PP-10 Probe Up Flow 316SS	1	19	513252	Retaining Ring 2-1/2" Shaft SS	1
	516728	HD-PP-10 Probe L to R Flow 316SS	1	20	523259	Lip Seal 1.00" I.D. x 1-1/2" O.D. x 1/4" VITON	2
	516729	HD-PP-10 Probe R to L Flow 316SS	1	21	524356	Thrust Washer Nylon 1" I.D. HD-PP	1
	524173	HD-PP-10 Probe Down Flow Nedox	1	22	513880	Washer Thrust 1" I.D. 2.0" O.D. 0.13" Thick	1
	524174	HD-PP-10 Probe Up Flow Nedox	1	23	513253	Gear Miter 28T 8 D.P.	2
	524175	HD-PP-10 Probe L to R Flow Nedox	1	24	513655	Guide Rod	4
	524176	HD-PP-10 Probe R to L Flow Nedox	1	25	513259	Probe Adjustment Rod HD-PP	2
2	513660	HD-PP-10 Auger 316SS (Standard)	1	26	513240	HD-PP Cylinder Guide Plate	1
	523523	HD-PP-10 Auger 316SS Nedox Coated	1	27	513251	HD-PP Drive Gear Spacer	1
3	513248	Seal Retainer SS HD-PP	1	28	513233	HD-PP Cylinder Mount Plate 6 Bore	1
4	513289	O-Ring 5" x 5-1/2" BUNA N	1	29	513653	Cover Plate Top and Bottom	2
5	516698	Seal Housing Down Flow	1	30	34355	Seal Dortite 1/8" Thick 1/2" W	20'
	516699	Seal Housing Up Flow	1	31	513657	Motor Side Plate	1
	516700	Seal Housing Left to Right Flow	1	32	513658	Limit Switch Side Plate	1
	516701	Seal Housing Right to Left Flow	1	33	513232	HD-PP Drive Shaft	1
6	520370	Auger End Bearing HD-PP	1	34	513115	Reducer Gear 30:1 Ratio Falk	1
7	513243	CVH Seal Set 3" x 3-1/4" x 1.947"	2	35	26242	Motor 1/2 HP 1 PH TEFC 56C	1
8	513245	HD-PP Front Seal Set Spacer 3.856L	1	36	26402	Switch Limit Nema 4 12	1
	524997	Front Seal Spacer 316SS	1	37	35341	Switch Limit Arm Roller Adjustment	1
9	513246	Middle Seal Spacer HD-PP	1	38	513662	Cylinder Air 6 B x 10 Stroke	1
	525020	Seal Spacer HD-PP Discharge 316SS 3.00" LG	1	39	514075	Air Valve Mount Bracket	1
10	513244	CVH Seal Set 3" x 3-1/4" x 0.747"	1	40	543184	Valve Air 3/8" NPT 120 VAC 2 Position 4 Way	1
11	513247	Seal Spacer Rear HD-PP	1	41	543180	Filter Regulator Assembly 3/8" NPT 125 PSI	1
	525021	Seal Spacer HD-PP Rear 316SS 2.81 LG	1	42	34044	Speed Control 3/8" NPT Adjustment BRAS	2
12	34432	Pipe Plug 3/8 NPT Brass	1	43	513290	Pipe Street Elbow 1/2" NPT 90°	1
13	27240	Compression Plate	1	44	513288	Fit Air Push-Loc 1/2" x 3/4" MPT Street	2
14	513237	HD-PP Discharge Tube 3.00" O.D.	1	45	24558	Fit Air Push-Loc 1/2" x 1/2" MPT Street	4
15	513242	HD-PP Seal Compression Plate	1	46	36636	Hose Air 1/2" I.D. Push-Loc	5'
16	513654	Bearing Housing	1	47	518997	HD-PP Extra Seal Spacer 4" LG	1
17	513238	O-Ring 2-1/4" x 2-1/2" BUNA N	2		524999	HD-PP Extra Seal Spacer 4" LG	1

* **NOTE:** Refer to certified drawing(s) for specific options.

NOTE: Refer to motor configuration drawing on [Page 54](#) for continuation of complete part listing.

HD-PP-12 Samplers 12" Stroke (525007)

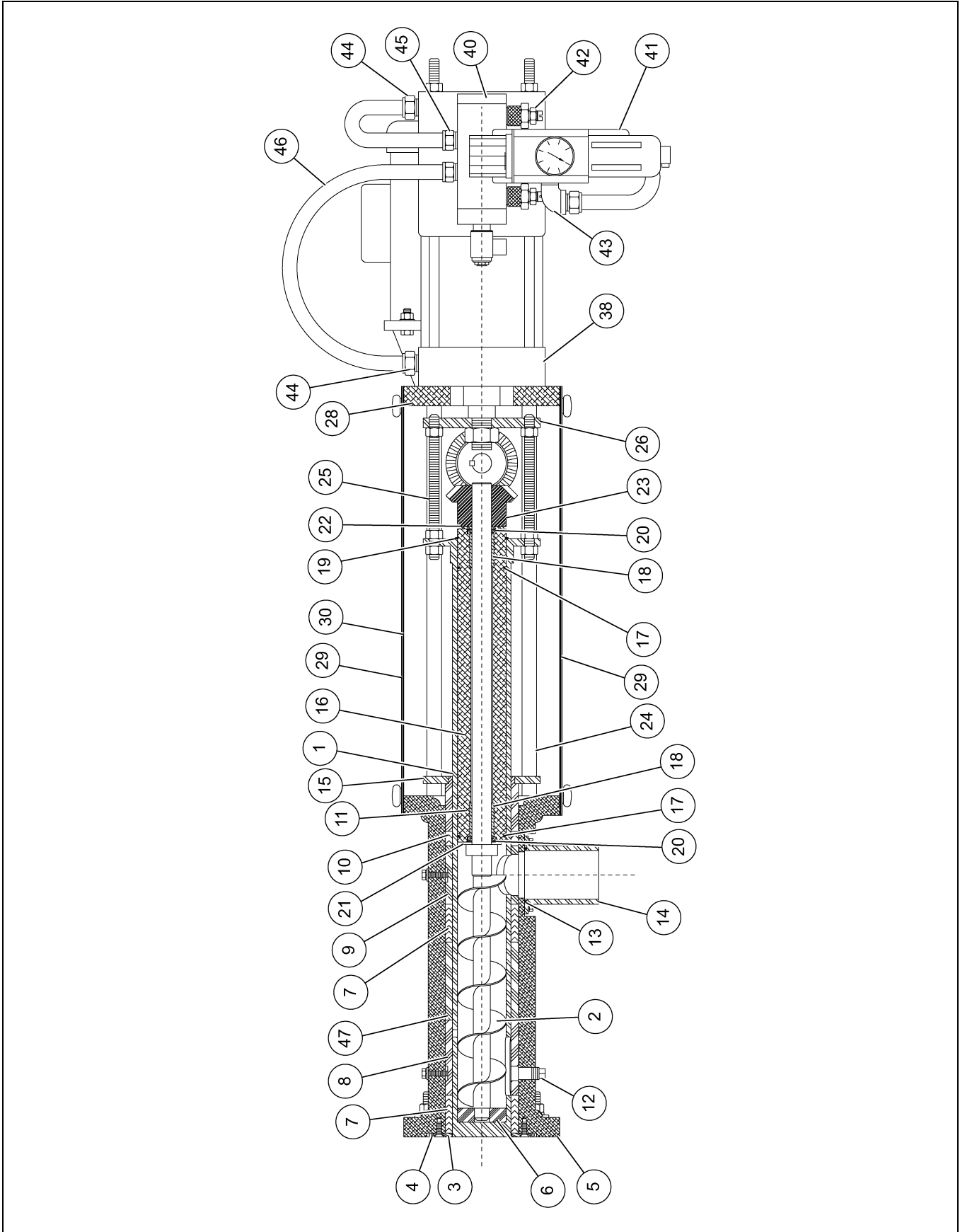

HD-PP-12 Samplers 12" Stroke (525007) Parts List

Ref #	Part #	Description	Qty	Ref #	Part #	Description	Qty
1	516731	HD-PP-12 Probe Down Flow	1	18	513257	Bushing Bronze 1" I.D. x 1-3/4" LG	2
	516732	HD-PP-12 Probe Up Flow 316SS	1	19	513252	Retaining Ring 2-1/2" Shaft SS	1
	516733	HD-PP-12 Probe L to R Flow 316SS	1	20	523259	Lip Seal 1.00" I.D. x 1-1/2" O.D. x 1/4" VITON	2
	516734	HD-PP-12 Probe R to L Flow 316SS	1	21	524356	Thrust Washer Nylon 1" I.D. HD-PP	1
	524177	HD-PP-12 Probe Down Flow Nedox	1	22	513880	Washer Thrust 1" I.D. 2.0" O.D. 0.13" Thick	1
	524178	HD-PP-12 Probe Up Flow Nedox	1	23	513253	Gear Miter 28T 8 D.P.	2
	524179	HD-PP-12 Probe L to R Flow Nedox	1	24	514457	Guide Rod SS HD-PP-12	4
	524180	HD-PP-12 Probe R to L Flow Nedox	1	25	513259	Probe Adjustment Rod HD-PP	2
2	514498	HD-PP-12 Auger Purchased	1	26	513240	HD-PP Cylinder Guide Plate	1
	524155	HD-PP-12 Auger 316SS Nedox Coated	1	27	513251	HD-PP Drive Gear Spacer	1
3	513248	Seal Retainer SS HD-PP	1	28	513233	HD-PP Cylinder Mount Plate 6 Bore	1
4	513289	O-Ring 5" x 5-1/2" BUNA N	1	29	514449	HD-PP-12 Cover Plate	2
5	516703	Seal Housing Down HD-PP-12	1	30	34355	Seal Dorteite 1/8" Thick 1/2" W	20'
	516704	Seal Housing Up Flow	1	31	514465	HD-PP-12 Motor Side Plate	1
	516705	Seal Housing Left to Right Flow	1	32	514469	HD-PP-12 Limit Switch Side Cover	1
	516706	Seal Housing Right to Left Flow	1	33	513232	HD-PP Drive Shaft	1
6	520370	Auger End Bearing HD-PP	1	34	513115	Reducer Gear 30:1 Ratio Falk	1
7	513243	CVH Seal Set 3" x 3-1/4" x 1.947"	2	35	26242	Motor 1/2 HP 1 PH TEFC 56C	1
8	514079	HD-PP Front Seal Set Spacer 5.856 L	1	36	26402	Switch Limit Nema 4 12	1
	524998	HD-PP Front Spacer 316SS 5.856 L	1	37	35341	Switch Limit Arm Roller Adjustment	1
9	513247	Middle Seal Spacer HD-PP	1	38	514477	Cylinder Air 6 B x 12 Stroke MA	1
	525020	Middle Seal Spacer 316SS	1	39	514075	Air Valve Mount Bracket	1
10	513244	CVH Seal Set 3" x 3-1/4" x 0.747"	1	40	543184	Valve Air 3/8" NPT 120 VAC 2 Position 4 Way	1
11	513247	Seal Spacer Rear HD-PP	1	41	543180	Filter Regulator Assembly 3/8" NPT 125 PSI	1
	525021	Rear Seal Spacer 316SS	1	42	34044	Speed Control 3/8" NPT Adjustment BRAS	2
12	34432	Pipe Plug 3/8" NPT Brass	1	43	513290	Pipe Street Elbow 1/2" NPT 90°	1
13	27240	O-Ring 2-5/8" x 2-7/8" FDA	1	44	513288	Fit Air Push-Loc 1/2" x 3/4" MPT Street	2
14	513237	HD-PP Discharge Tube 3.00" O.D.	1	45	24558	Fit Air Push-Loc 1/2" x 1/2" MPT Street	4
15	513242	HD-PP Seal Compression Plate	1	46	36636	Hose Air 1/2" I.D. Push-Loc	5'
16	514453	Bearing Housing with Seals HD-PP-12	1	47	518997	HD-PP Extra Seal Spacer 4" LG	1
17	513238	O-Ring 2-1/4" x 2-1/2" BUNA N	2		524999	Extra Seal Spacer 316SS	1

* **NOTE:** Refer to certified drawing(s) for specific options.

NOTE: Refer to motor configuration drawing on [Page 54](#) for continuation of complete part listing.

HD-PP Motor Configuration View (525011)

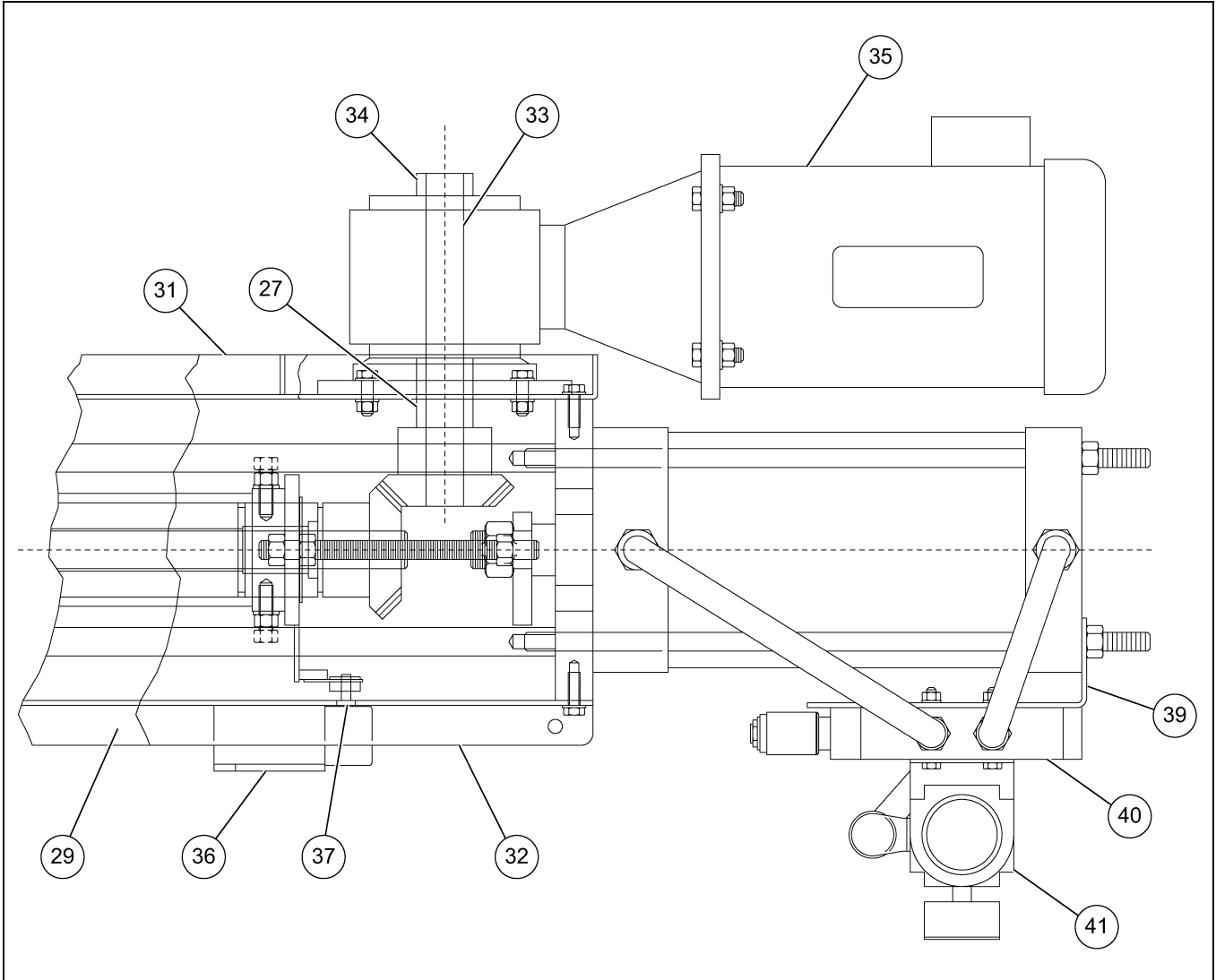

NOTE: For parts list, refer to HD-PP-6 through HD-PP-12 on [Pages 47-53](#).

InterSystems, Inc. reserves the right to make changes in design or in construction of equipment and components without obligation to incorporate such changes in equipment and components previously ordered.

WARRANTY, LIMITATION OF LIABILITY, DISCLAIMER OF IMPLIED WARRANTIES: InterSystems, Inc. manufactured equipment and components are guaranteed against defects in workmanship or materials for one year from date of shipment. The obligation of InterSystems, Inc. with respect to any goods is limited to replacement or repair of defective parts and equipment provided those parts are returned, shipping costs prepaid, to InterSystems' factory and provided the product has not been subject to misuse, negligence, or accident, or repaired or altered outside of our factory, or other than by an Authorized Service Representative. This warranty does not cover the replacement of parts inoperative because of wear occasioned by use, the cost of replacing parts by a person other than an InterSystems employee or an Authorized Service Representative, or the adjustment of a product where the product was improperly adjusted by the purchaser. In addition, this warranty does not cover components manufactured by others such as motors, drives, clutches, cylinders, valves, blowers, and the like. On those components the standard Manufacturers' warranty applies. In any event, liability is limited to the purchase price paid, and InterSystems, Inc. will, under no circumstances, be responsible for special or consequential damages, or for incidental damages.

INTERSYSTEMS, INC. NEITHER MAKES NOR AUTHORIZES ANY WARRANTY OTHER THAN AS HEREIN CONTAINED. THIS WARRANTY IS IN LIEU OF ALL OTHER WARRANTIES, EXPRESS OR IMPLIED, INCLUDING THOSE OF MERCHANTABILITY AND FITNESS FOR A PARTICULAR PURPOSE.

This equipment shall be installed in accordance with the current installation codes and applicable regulations, which should be carefully followed in all cases. Authorities having jurisdiction should be consulted before installations are made.



InterSystems
9575 N. 109th Ave.
Omaha, Nebraska 68142
Toll Free: (800) 228-1483
www.gsiag.com



InterSystems is a part of GSI, a worldwide brand of AGCO Corporation.