

CE Compliant Bulk Weigher

Installation and Operation Manual -
Original Instructions

PNEG-2268CE

Version: 2.0

Date: 03-17-21



PNEG-2268CE

All information, illustrations, photos and specifications in this manual are based on the latest information available at the time of publication. The right is reserved to make changes at any time without notice.

Contents

Chapter 1 Safety	5
Safety Guidelines	5
Cautionary Symbol Definitions	6
Safety Cautions	7
Working at Heights	10
Location	10
Electrical Safety	11
Correct Use of the Bulk Weigher	12
Dealing with Blockages	13
Hydraulic Fluid Spillage	13
Hydraulic System	13
ATEX Compliance	14
Extraction and Filtration System	15
Safety Sign-Off Sheet	16
Chapter 2 Installation	17
Bulk Weigher - General Electrical Layout	17
Bulk Weigher Installation	18
Hydraulic System Installation	18
Bulk Weigher - Extraction System Installation	21
Electrical Connections	31
Load Cell Connections	35
Chapter 3 Operation	36
Commissioning	36
Start-Up	37
Power and Safety Panel Fault Lights	39
Chapter 4 Maintenance	40
Upon Receipt of Shipment	40
Every Day	40
Every Six (6) Months	40
Every Twelve (12) Months	43
Chapter 5 Troubleshooting	44
Gate Malfunctions	44
Chapter 6 Bulk Weigher Parts Information	45
Series 2H Heavy Duty Hydraulic Cylinder Parts	45
Cast Iron Test Weights	52
Manual Test Weight Lift Assembly 500#	56
Manual Test Weight Lift Assembly 1000#	57
Manual Test Weight Lift Assembly 2000#	58
Hydraulic Test Weight Lift Assembly 1000#	59
Chapter 7 Hydraulic Power Unit Schematic Drawings	60
Hydraulic Power Unit 5 HP TEFC PSR/COMP (532295)	60
Hydraulic Power Unit 5 HP IIG PSR/COMP (532304)	62
Hydraulic Power Unit 7.5 HP TEFC PSR/COMP (532303)	64
Hydraulic Power Unit 7.5 HP IIG PSR/COMP (532305)	66
Auto Lift Kit Hydraulic Power Unit (IIG) (532300)	68

Table of Contents

Chapter 8 Hydraulic Power Unit Parts Information	69
Pressure Compensating Piston Pump	69
Suction Strainer	74
Fluid Level and Temperature Switches	76
Chapter 9 Appendix A	78
Sampler Control Gate Orientation	78
Chapter 10 Appendix B - Hydraulic System Schematics	79
Hydraulic Schematic 5 HP Pressure Component 1W (532396)	80
Hydraulic Schematic 5 HP Pressure Compound Trim (534257)	81
Hydraulic Schematic 7.5 HP Pressure Compound 1W (532377)	82
Hydraulic Schematic 7.5 HP Pressure Compound Trim (732392)	83
Chapter 11 Appendix C - Electrical System Schematics	84
MasterWeigh/Jaguar I/O Field Wiring (531192)	85
BP Electrical Schematics Trim Standard (526746)	86
BC Electrical Schematic Standard (526776)	87
CD2000 to CD4000 I/O Field Wiring Schematics (528116)	88
Chapter 12 Appendix D - Easy Clean Installation	89
Description	89
Compressed Air	89
Electrical Connections	91
Proposed Cleaning Control System	93
Options	95
Chapter 13 Appendix E - Electronic Sequencer (Model MTS)	96
Technical Characteristics	96
Features	96
Installation	97
Preliminary Checks	97
Electrical Connections of the Valves	97
Start-Up	98
Remote	100
Shut Down Cleaning	101
Troubleshooting	101
General Assembly (MTS 4-16)	102
MTS Front Panel	104
Chapter 14 Warranty	105

Safety Guidelines

Safety guidelines are general-to-specific safety rules that must be followed at all times. This manual is written to help you understand safe operating procedures and problems that can be encountered by the operator and other personnel when using this equipment. Read and save these instructions.

As owner or operator, you are responsible for understanding the requirements, hazards, and precautions that exist and to inform others as required. Unqualified persons must stay out of the work area at all times.

Alterations must not be made to the equipment. Alterations can produce dangerous situations resulting in **SERIOUS INJURY** or **DEATH**.

This equipment must be installed in accordance with the current installation codes and applicable regulations, which must be carefully followed in all cases. Authorities having jurisdiction must be consulted before installations are made.

When necessary, you must consider the installation location relative to electrical, fuel and water utilities.

Personnel operating or working around equipment must read this manual. This manual must be delivered with equipment to its owner. Failure to read this manual and its safety instructions is a misuse of the equipment.

ST-0001-4

Cautionary Symbol Definitions

Cautionary symbols appear in this manual and on product decals. The symbols alert the user of potential safety hazards, prohibited activities and mandatory actions. To help you recognize this information, we use the symbols that are defined below.



This symbol indicates an imminently hazardous situation which, if not avoided, **will result in serious injury or death.**



This symbol indicates a potentially hazardous situation which, if not avoided, **can result in serious injury or death.**



This symbol indicates a potentially hazardous situation which, if not avoided, **can result in minor or moderate injury.**



This symbol is used to address practices not related to personal injury.



This symbol indicates a general hazard.



This symbol indicates a prohibited activity.



This symbol indicates a mandatory action.

ST-0005-2

Safety Cautions

Use Personal Protective Equipment

- Use appropriate personal protective equipment:

Eye Protection



Respiratory Protection



Foot Protection



Hearing Protection



Head Protection



Fall Protection



Hand Protection



- Wear clothing appropriate to the job.
- Remove all jewelry.
- Tie long hair up and back.

ST-0004-1

Follow Safety Instructions

- Carefully read all safety messages in this manual and safety signs on your machine. Keep signs in good condition. Replace missing or damaged safety signs. Be sure new equipment components and repair parts include the current safety signs. Replacement safety signs are available from the manufacturer.
- Learn how to operate the machine and how to use controls properly. Do not let anyone operate without instruction.
- If you do not understand any part of this manual or need assistance, contact your dealer.



ST-0002-1

1. Safety

Maintain Equipment and Work Area

- Understand service procedures before doing work. Keep area clean and dry.
- Never service equipment while it is operating. Keep hands, feet, and clothing away from moving parts.
- Keep your equipment in proper working condition. Replace worn or broken parts immediately.



ST-0003-1

Stay Clear of Hoisted Equipment

- Always use proper lifting or hoisting equipment when assembling or disassembling equipment.
- Do not walk or stand under hoisted equipment.
- Always use sturdy and stable supports when needed for installation. Not following these safety precautions creates the risk of falling equipment, which can crush personnel and cause serious injury or death.



ST-0047-1

Sharp Edge Hazard

- This product has sharp edges, which can cause serious injury.
- To avoid injury, handle sharp edges with caution and always use proper protective clothing and equipment.



ST-0036-2

Install and Operate Electrical Equipment Properly

- Electrical controls must be installed by a qualified electrician and must meet the standards set by applicable local codes (National Electrical Code for the US, Canadian Electric Code, or EN60204 along with applicable European Directives for Europe).
- Lock-out power source before making adjustments, cleaning, or maintaining equipment.
- Make sure all equipment is properly grounded.



ST-0027-4

Stay Clear of Moving Parts

- Stay clear - machine can start without warning.
- Entanglement in gate will cause serious injury.
- Keep all shields and covers in place at all times.
- Lock-out power source before making adjustments, cleaning, or maintaining equipment.



ST-0070-1

Fall Hazard

- Ladders, stairways and platforms are for use by competent and trained personnel only. Do not allow children or other unauthorized persons to have access to the equipment.
- Access to the equipment must be restricted by the use of security fencing and lockable gates.
- Lower sections of ladders must be fitted with a lockable safety gate to prevent unauthorized access.
- Make sure that hot surfaces have had adequate time to cool before working on or in the equipment.
- Lock out and tag out power supplies and fuel supplies to all equipment.
- Do not attach lifting equipment to ladders or platforms.
- Do not go outside of the safety rails provided on elevated platforms.
- Do not work at heights during high winds, rain, snow, or ice storms.



ST-0056-1

1. Safety

Working at Heights

The weigher has been designed to operate primarily from the ground level. At some stages during the life cycle, it may be necessary to work at heights. For this reason, the equipment has been provided with access ladders and platforms, to minimise the risk to health and safety. In addition attention should be paid to the following safety requirements.

1. The ladders, platforms and walkways are for use by competent and trained personnel only. NEVER allow children or members of the general public to gain access to the equipment, its ladders or access platforms.
2. Where the equipment is sited in an unsecured location, access must be restricted by use of security fencing and lockable gates.
3. Lower sections of ladders on the equipment should be fitted with a lockable safety gate, to prevent unauthorised access.
4. The equipment should be OFF and all power LOCKED OFF before work on or in the equipment. Ensure the power isolator is OFF and LOCKED and TAGGED to prevent inadvertent re-start. This must include all equipment attached to the elevator on which you are working.



Figure 1A

5. NEVER attach lifting equipment to ladders or platforms.
6. When working on the equipment, NEVER go outside the safety rails provided.
7. Do not work at heights during high winds, heavy rain, snow, ice or storm.

The majority of routine service can be carried out from the service platforms provided. In the rare event that access is required outside these structures additional access and safety equipment may be required, such as powered access lift platforms and safety harness. Such work must only be carried out by specialist technicians trained and qualified in working at heights and only after a complete risk assessment has been carried out and safe working methods established.

Location

1. The weigher must be installed in a location where it can have adequate structural support, remain level and be free of vibration or shock.
2. Free flow of material in, and out of the weigher is essential.
3. It shall not be installed in an enclosed, potentially explosive area, (HAZARDOUS/HAZLOC/ATEX designated location).

Electrical Safety



Equipment shall include:

1. Fuse protected main power supply.
 - a. The electrical supply should include earth leakage protection, eg. residual current device (RCD) or residual current circuit breaker (RCCB), to provide automatic disconnection in the event of a fault.

2. Lockable main safety disconnect.



- a. Disconnects all electrical power.

3. Lockable motor service disconnect.

- a. Adjacent to each motor (or group of motors).
 - b. Disconnects all power to the motors.



4. Emergency stops.



- a. Stops all equipment immediately when pressed.
 - b. Must remain engaged until manually disengaged.
 - c. Equipment shall not immediately re-start when the emergency stop is re-set.

5. Door safety interlocks - where doors provide access to dangerous machinery.

- a. Immediately stops and prevents re-start of all equipment when the door is open.
 - b. Equipment shall not immediately re-start when the door is closed.
 - c. Safety switches shall be SIL3 in accordance with IEC62061:2005.



6. Safety circuits should be minimum PL“c” in accordance with ISO 13849-1:2006.

7. The electrical supply must include a properly designed protective earth system (PE), with connection to all exposed conductive parts.

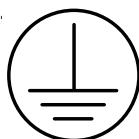

8. All motors shall be connected to protective earth at the terminal provided.

1. Safety

9. The control system shall include,
 - a. Short circuit protection.



- b. Equipment shall not immediately re-start following re-establishment of power.
10. All electrical design, installation and testing must be carried out by a qualified electrical engineer, in accordance with EU Directives and Standards, local laws and codes.

Correct Use of the Bulk Weigher

1. These weighers are designed solely for weighing whole agricultural grain and seeds. Use for any other material is a misuse and could result in serious injury and equipment damage.
2. It shall NOT be used for:
 - a. Powders
 - b. Fertilizers
 - c. Liquids
 - d. Sludges or slurries
 - e. Manures
 - f. Sand
 - g. Stone
 - h. Chemicals
 - i. Other non-flowing materials
3. Never operate the bulk weigher without completely enclosing the inlet or outlet, making all moving parts inaccessible to any person.
4. Never operate with guards removed or inspection covers open.
5. Never open or work on the bulk weigher unless:
 - a. It is locked out and tagged out at the main electrical isolator.
 - b. All hydraulic or pneumatic pressure has been safely dissipated.
 - c. All equipment working with the weigher are also locked out and tagged out.
 - d. The weigher is completely empty of all materials.
6. Do not fix a hoist or other lifting equipment to the bulk weigher, nor to the ladders or platforms attached to the weigher.
7. Ladders and platforms attached to the weigher are for personnel access only and must not be used to carry or support heavy pieces of equipment.
8. Do not exceed the maximum ladder and platform load, noted on the warning decal.
9. Never alter or adjust the weigher from it's original specification.
10. Never operate any part of the weigher manually. The only operating position is at the weigher control panel in the plant room.

Dealing with Blockages

Blockages in the weigher can be avoided by ensuring that it is only used for free flowing grains, which are of a low moisture content and angle of repose no greater than 35°.

In the extremely rare event that a blockage does occur:

1. Never go inside the weigher to manually dislodge the blockage.
2. If the blockage cannot be dislodged by operation of the slide gates from outside the weigher, it must be addressed by removal of all grain using a suction system.
3. This will require a specialist team and must only be carried out after full risk assessment and according to safe methods of work.

Hydraulic Fluid Spillage

1. Any leak or spillage of hydraulic fluid should be cleaned up immediately to reduce the risk of a hazardous, slipper surface and local water pollution.
2. Leaks should be detected and repaired immediately.
3. Apply absorbent material over any spillage; remove once fluid has been absorbed; wash surface with suitable detergent.

Hydraulic System

Extreme care needs to be taken when working on or near high pressure hydraulics. High pressure fluid and cause serious injury and death. Only carry out work on the system if you are competent, fit and trained to do so.

1. Wherever possible, work on the system only when it is isolated from all power and de-pressurised.
2. Always wear hand, eye, body and face protection.
3. When first commissioning the system, or following replacement of a component, air may need to be bled from the system.
4. Even when powered OFF, the hydraulic system may retain stored pressure. When working on or around the weigher, follow this procedure:
 - a. Shut OFF the hydraulic pump
 - b. Keep the operators control powered
 - c. Shut OFF and lock the main power disconnect
 - d. Keep the key in your possession only

ATEX Compliance

1. The Bulk Weigher is NOT designed for use within a location designated a potentially explosive (ATEX/HAZLOC).
2. ATEX compliance relates solely to the dust and air mix which may occur inside the weigher.
3. Provision of a dust extraction and filtering system is the primary measure used to control the risk of an explosive mixture of dust and air inside the weigher. As such, the ATEX rating inside the weigher is defined as 22D.
4. Air flow through the extraction system is constantly monitored. The weigher will not operate unless the minimum air flow is detected.
5. Fluid temperatures in the hydraulic system are constantly monitored. Exceeding the pre-set limits will result in the weigher being stopped from working or failing to start-up.
6. The operator must ensure that:
 - a. All air inlets to the weigher are kept clear of dust, debris, ice or any other blockage.
 - b. Pressure switches and pressure tappings on the extraction system are not damaged or tampered with.
 - c. All extraction duct work is correctly connected and free from blockages, dents and other damage.
 - d. All safety switches and sensors are functional and remain correctly connected to the control system.
 - e. Replacement parts must be genuine GSI/InterSystems and carry the same or better Ex rating.
 - f. The filter unit has a suitable, reliable compressed air supply.
 - g. Dust collected by the filter is handled and disposed of safely.
 - h. Any loss of airflow is rectified immediately.
 - i. Any cause of excess hydraulic temperature is investigated and rectified.
 - j. No safety features are by-passed or rendered in-operative.
 - k. Electrical earth bonding is installed and tested to all parts of the weigher, to ensure any generated static electricity can be safely discharged.
7. All equipment operating inside the weigher is rated or protected to a minimum Ex II3D T100°C.
8. The weigher is rated as Ex II 3/- T100°C.
9. Refer to the Ignition Source Assessment for further information.

Extraction and Filtration System

Details of the system provided with your model of weigher will be given in the certified drawings.

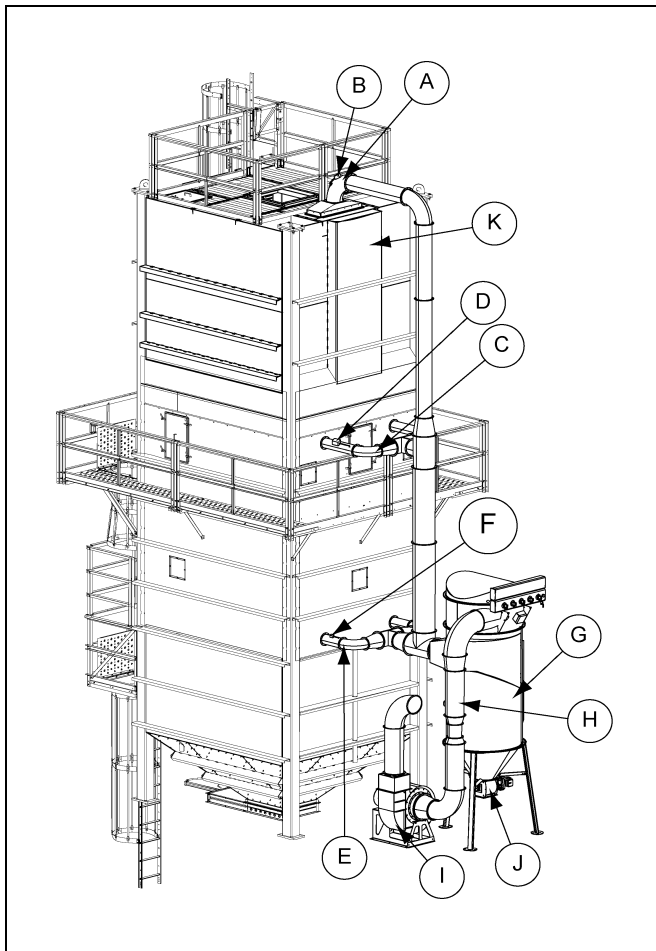

Figure 1B Bulk Weigher Extraction System

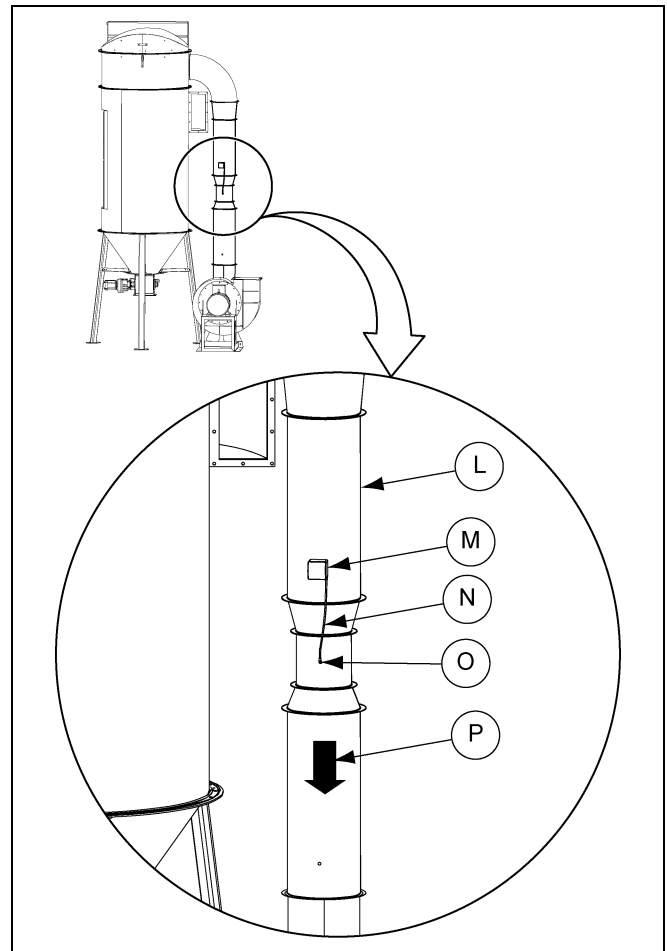

Figure 1C Air Flow Monitoring Venturi

Ref #	Description
A	Upper Garner Connection
B	Upper Pressure Switch
C	Weigh Hopper Connections
D	Mid Pressure Switch
E	Lower Garner Connections
F	Lower Pressure Switch
G	Filter Unit
H	Air Flow Monitoring Venturi
I	Fan
J	Rotary Valve
K	Bulk Weigher

Ref #	Description
L	Venturi Duct Assembly
M	Differential Pressure Switch Including High Pressure Tapping
N	Connecting Tube
O	Low Pressure Tapping
P	Direction of Airflow

Bulk Weigher - General Electrical Layout

1. The power and safety control (K) and the MWI weigher control should be located in a control room, close to each other.
2. All electrical connections to items inside the weigher must be completed using ATEX compliant conduit and/or cable glands.
3. All connections to door safety switches and additional emergency stops must be made to terminals inside the power and safety control (K).

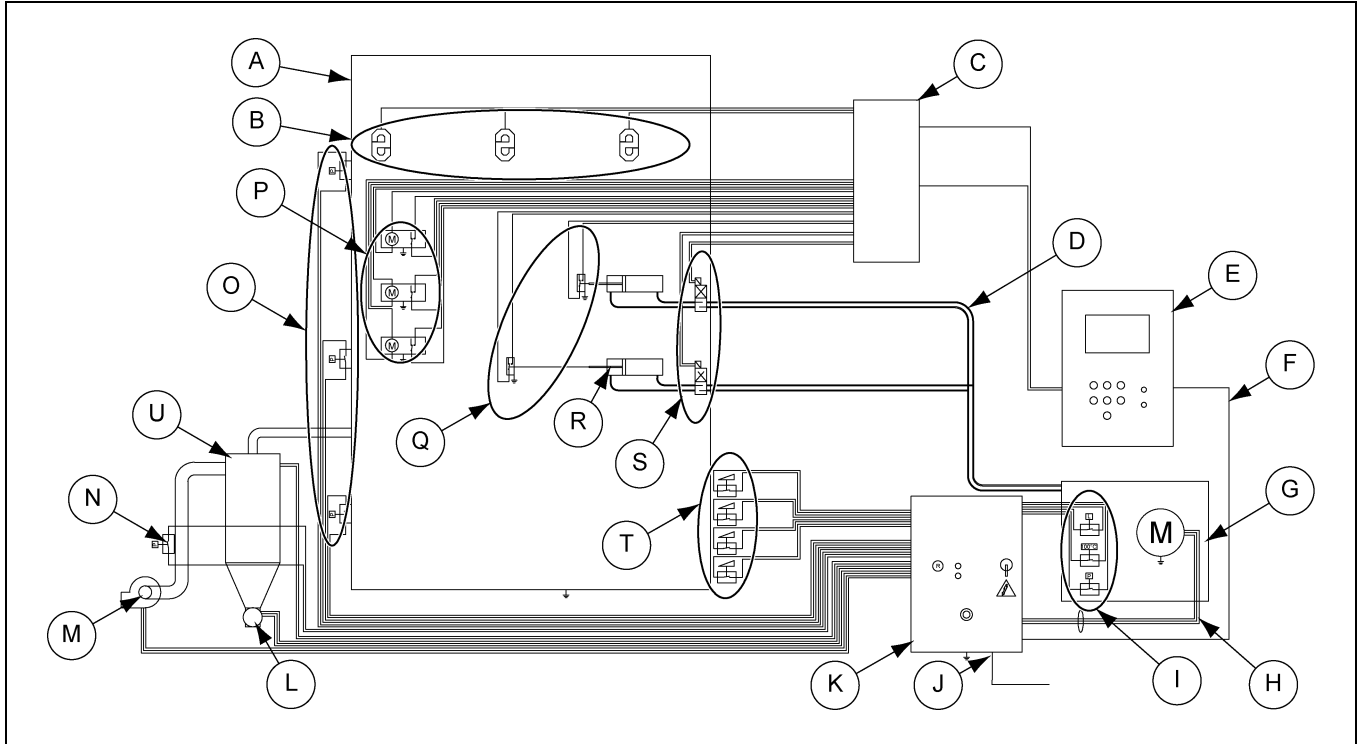

Figure 2A Electrical Layout

Ref #	Description
A	Bulk Weigher
B	Load Cells
C	Junction Box
D	Field Plumbing
E	MWI Weigher Control
F	Safety Controlled 220 VAC
G	Hydraulic Power Unit
H	Safety Controlled 380 VAC
I	Hydraulic Thermal and Pressure Safety High-Limits
J	380 VAC Three Phase and Neutral Supply
K	Power and Safety Control Panel

Ref #	Description
L	Rotary Valve
M	Fan
N	Air Flow Switch
O	Static Pressure Switches
P	Indicator Level Switches
Q	Gate Limit Switches
R	Gate Cylinders
S	Gate Solenoids
T	Access Panel Safety Switches
U	Filter

2. Installation

Bulk Weigher Installation

1. All mechanical assembly, including welding to tower structures and hoppers must be completed, before installing the load cells.
2. Install hoppers and structure according to the hopper general arrangement drawing. This includes: skirting, venting, structure, test weights, etc. (If crane weights are necessary consult with InterSystems).

Hydraulic System Installation

1. Locate the power units as close to the hopper gates as feasible. This will minimize the necessary plumbing and will reduce the line pressure drops.
2. Hydraulic flow and return pipes, plus all fittings shall be selected in accordance with EN4413.
3. Component and pipe pressure rating shall be rated to minimum 200 bar. See *below* table for Minimum hydraulic pipe specification (DIN 2391/C ST37.4).
4. **NOTE:** *Thread types on inlet/outlet connections are NPT.*
 - a. Do not use other thread types. Leakage may occur.
 - b. Where metric tube and fittings are used, use a thread adaptor.
5. Run the hydraulic plumbing from the power unit to the gate valves according to hydraulic schematic. (*See Figure 2B on Page 19.*)
6. Ensure all pipes are adequately supported and secured.
7. Carry out pressure tests on the hydraulic system and provide declaration of compliance with EN4413.

Minimum Hydraulic Pipe Specification (DIN 2391/C ST37.4)

Weigher Models	BMW-013 – BMW-780	BMW-840 - BMW-1650
Flow	25 mm O.D. x 3 mm	38 mm O.D. x 4 mm
Return	20 mm O.D. x 2.5 mm	25 mm O.D. x 3 mm

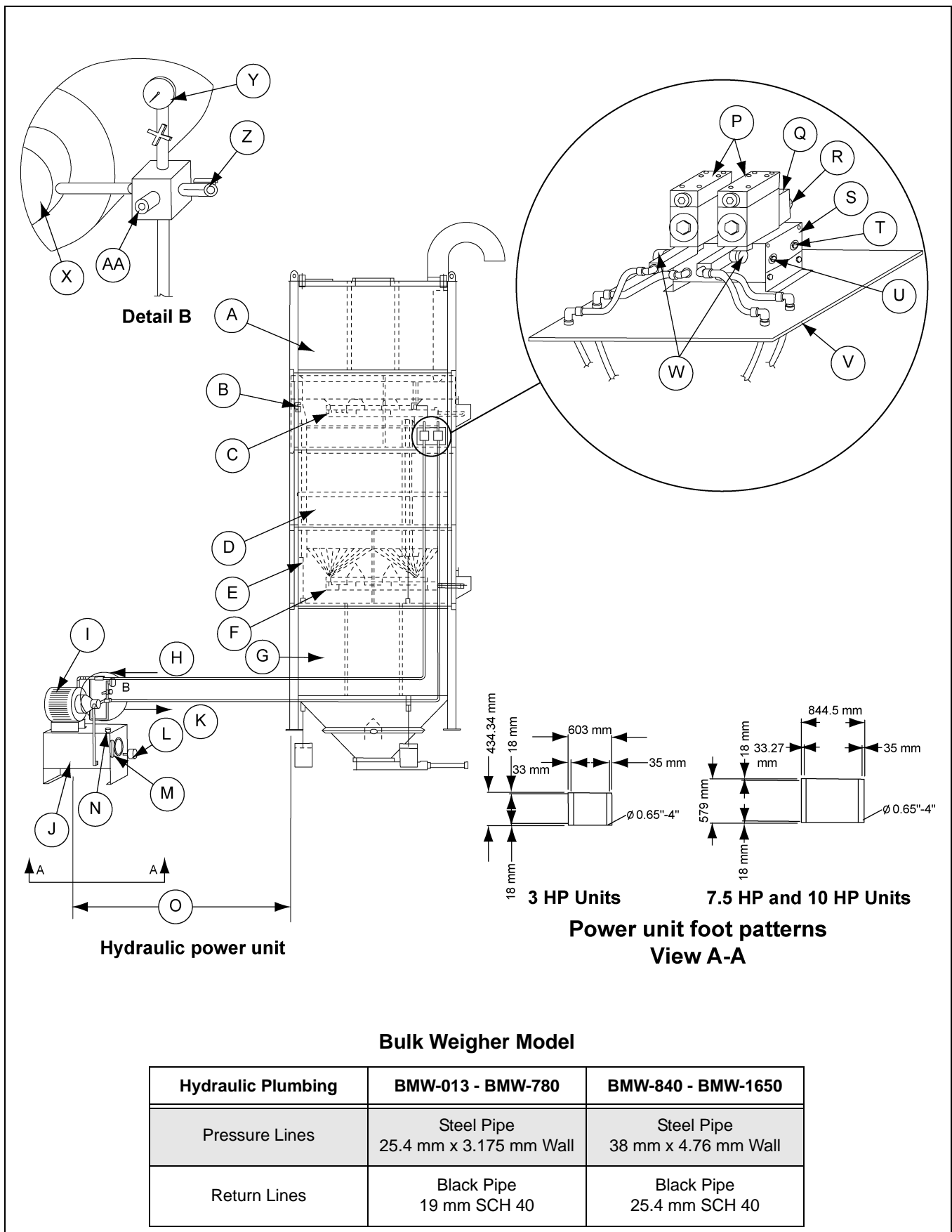

Figure 2B Hydraulic System Arrangement

Hydraulic System Arrangement

Ref #	Description
A	Upper Garner
B	See Load Cell Assembly Detail (See Page 28.)
C	Feed (Fill) Gate
D	Weigh Hopper
E	Refer to Test Weight Lift Assembly Detail. (See Figure 2T on Page 30.)
F	Discharge (Empty) Gate
G	Lower Garner
H	Tank Return Side
I	Motor
J	Oil Tank
K	Pressure Side
L	Heater
M	Level/Temp Gauge
N	Filter/Breather Cap
O	15.24 m (50') Maximum
P	Hydraulic Valves
Q	Solenoids
R	Manual Override Button
S	Valve Manifold
T	Tank Return Line to Return Filter Side of Power Unit
U	Pressure Line From Pump Side of Power Unit
V	Skin Sheets
W	Flow Adjustment Knobs
X	Pump
Y	Pressure Gauge
Z	Shut Off Valve
AA	Pressure Relief Valve

Bulk Weigher - Extraction System Installation

Refer to the detailed, certified drawing, for your extraction system.

Installing the Static Pressure Switches

For ease of access, fit the duct mounted static pressure switches (A) with the duct on the ground. Take care not to damage the switches when lifting the duct into position.

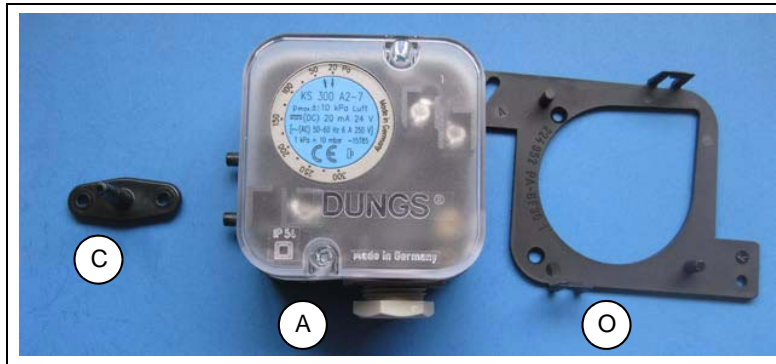

Figure 2C

1. Three (3) pressure switches (A) are installed on the ducting to check for negative pressure at each connection point on the weigher. (See Figure 1B on Page 15.)
2. Location of these switches is not critical, but should be close to the point at which the ducting connects to the weigher.

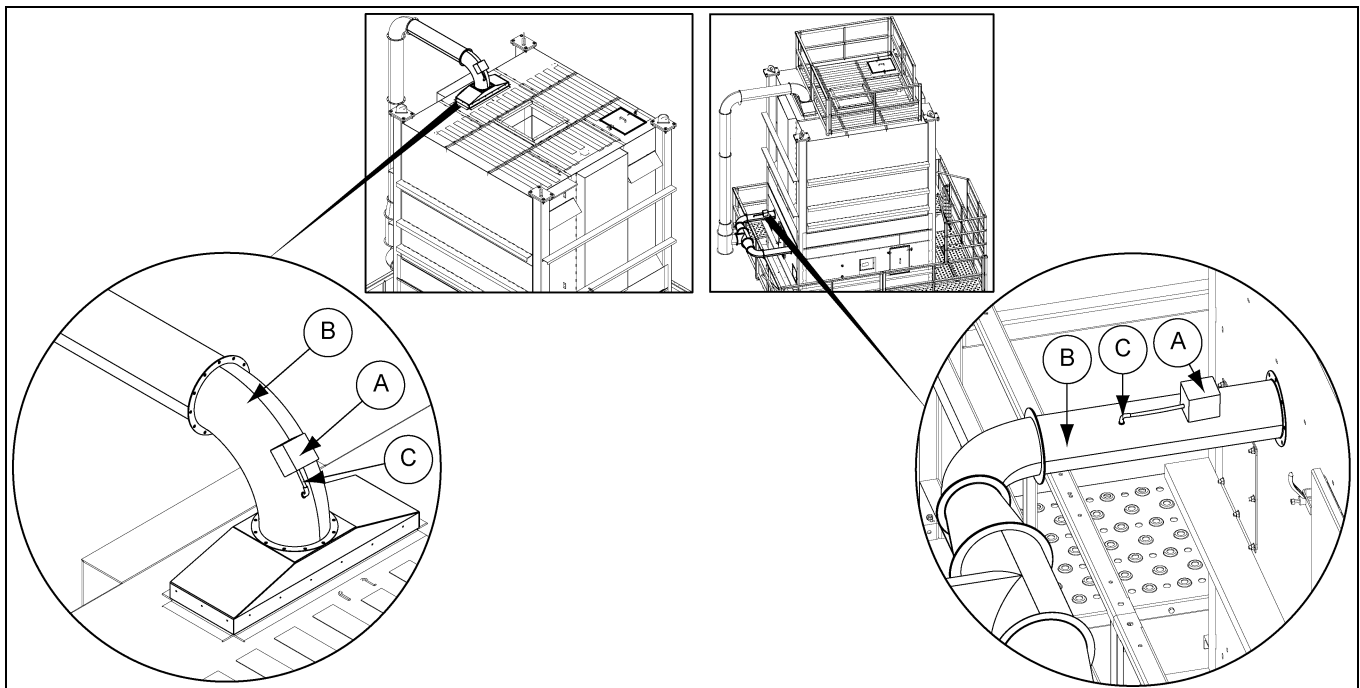

Figure 2D Typical Pressure Switch Positions on Upper and Mid/Lower Locations

Ref #	Description	Ref #	Description
A	Pressure Switch	C	Pressure Tapping
B	Tube	O	Mounting Plate

2. Installation

- a. Drill the duct with a 10 mm hole.
- b. Offer up the pressure tapping (C) and mark/drill the screw holes.
- c. Fit the tapping with 2 x thread cutting screws.
- d. Choose a suitable location to mount the switch (it needs to be accessible from the service platform).
- e. Offer up the mounting bracket, mark and drill the screw holes.
- f. Fix with thread cutting screws and clip the switch in place.
- g. Cut the air tube (B) to length and push onto the switch negative (-) connection and into the pressure tapping (C).



Figure 2E Pressure Switch

Installing the Venturi Differential Pressure Switch

1. One differential pressure switch (A) is mounted onto the venturi duct. *(See Figure 1C on Page 15.)*
2. Position of this switch (A) and pressure tapping (C) is critical to the functioning of the air flow monitoring system. The pressure tappings are pre-fitted to the venturi duct.



Figure 2F Tapping on Large Duct



Figure 2G Tapping on Small Duct

Ref #	Description
D	Push Fit Tube Connector

3. If the push fit tube connector (D) has not been fitted into the smaller duct, use some PTFE sealant and fit it.
4. Locate the differential pressure switch (A) and fit the push fit tube connector (D) to the negative (-) pressure port on the underside of the switch.



Figure 2H *Differential Pressure Switch*



Figure 2I *PTFE Tape*

Ref #	Description
E	Push Fit Tube Connector on Negative Pressure Port
F	Positive Pressure Port

2. Installation

5. Apply PTFE tape to the thread of the tapping on the larger duct.
6. Fit the switch onto the duct.
7. Cut to length the air tube (B) and fit to the push fit connectors (D).

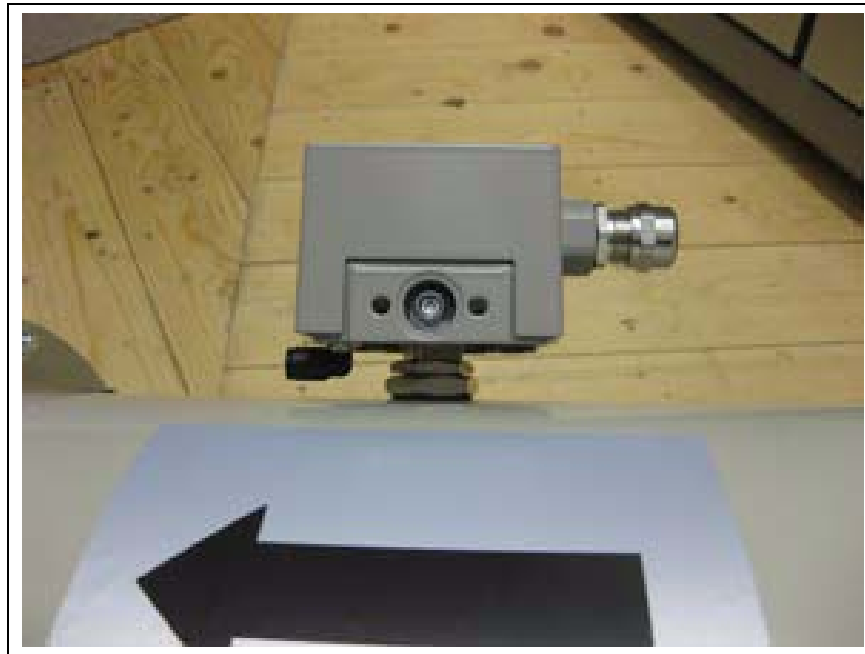

Figure 2J *Differential Pressure Switch on Venturi Duct*



Figure 2K *Air Tube Connection*

Assemble the Ducting

- Apply silicone to each flange.
- Support the duct assembly if required (supports not provided).

1. Start with the lower garner connections (G). (See Figure 2L.)

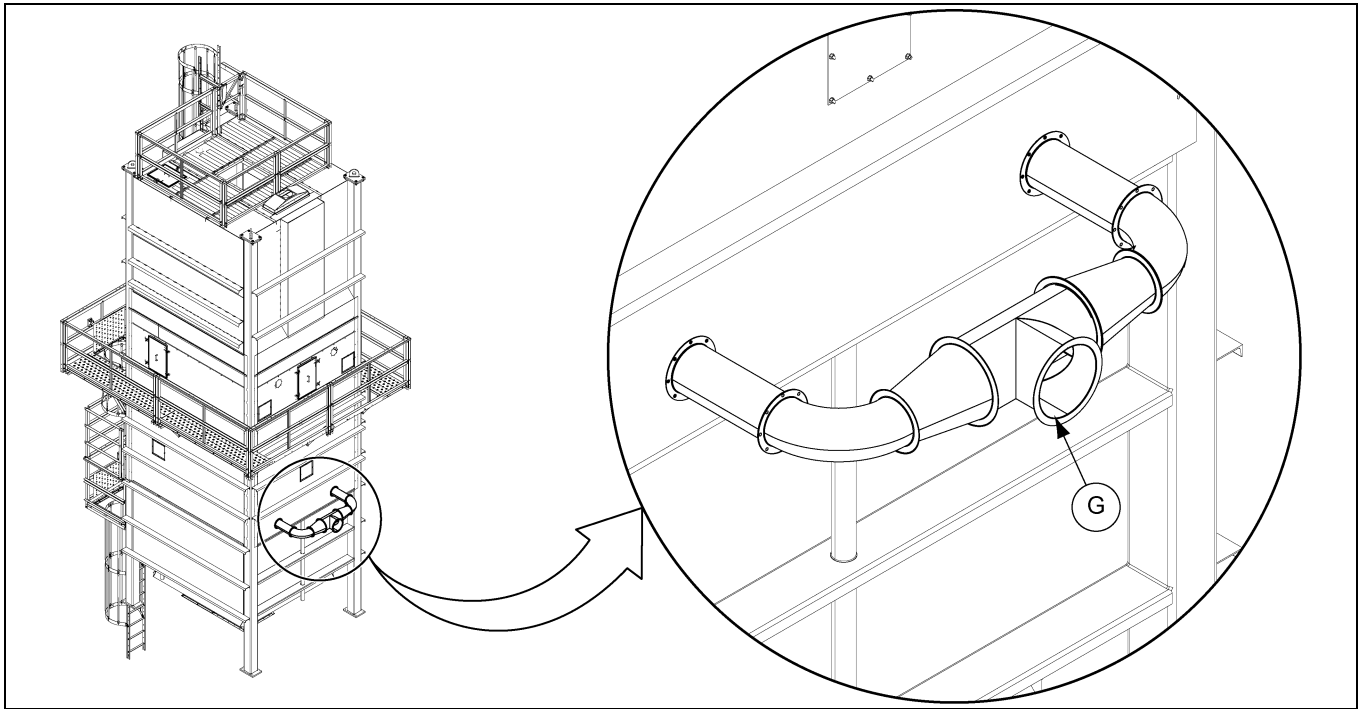

Figure 2L

Ref #	Description
G	Lower Garner Duct Section

2. Position the filter unit (H) and connecting duct (I). (See Figure 2M.)

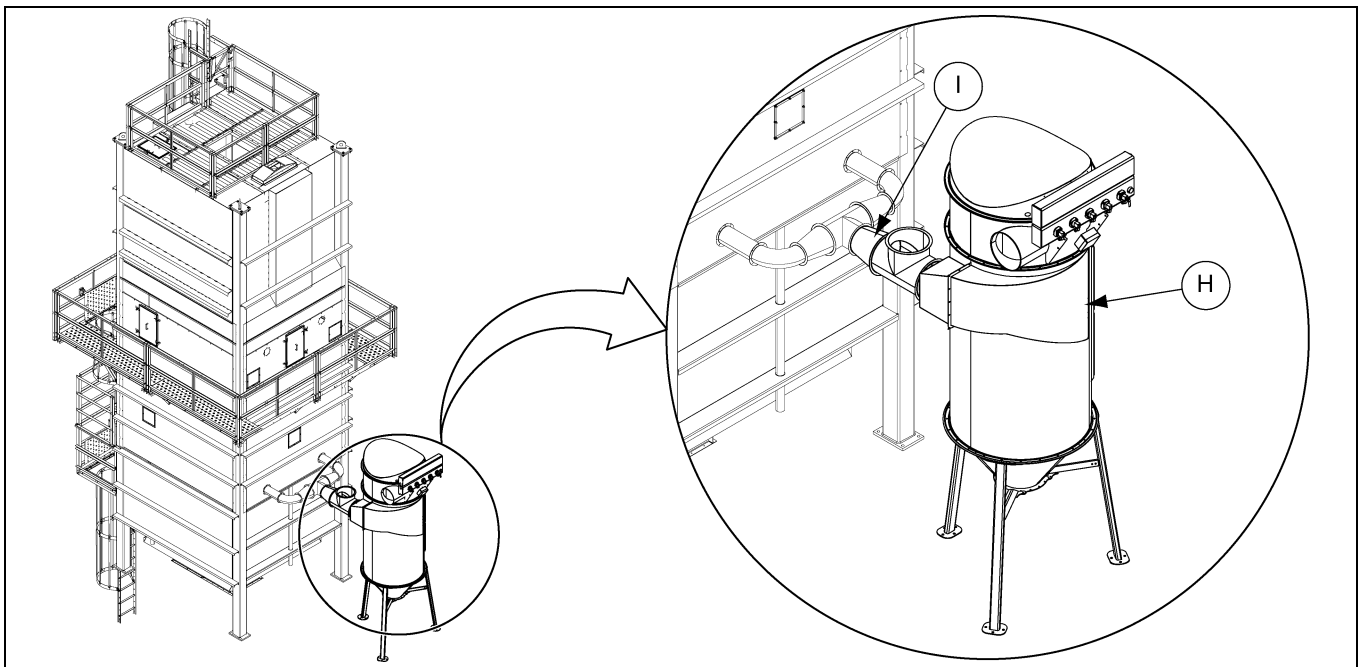

Figure 2M

Ref #	Description	Ref #	Description
H	Filter Unit	I	Filter Connecting Duct

2. Installation

3. Assemble the weigh hopper duct section (J). (See Figure 2N.)

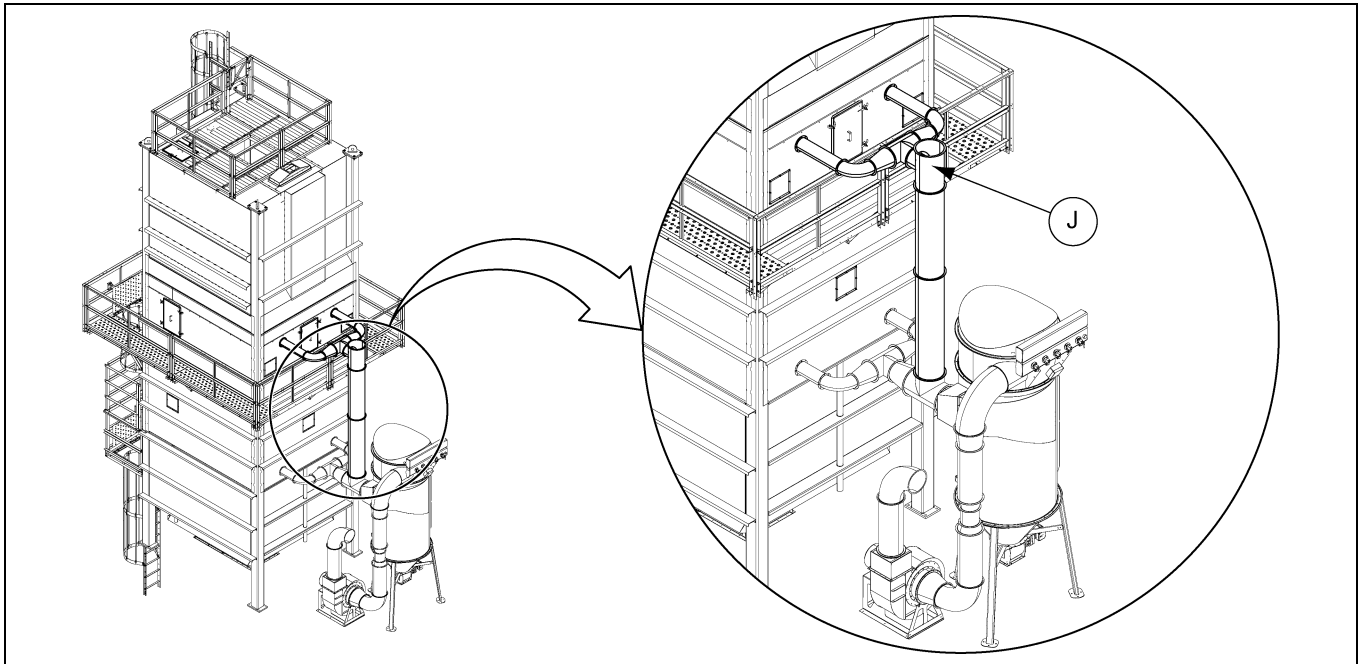

Figure 2N

Ref #	Description
J	Weigh Hopper Duct Section

4. Assemble upper garner duct section (K). (See Figure 2O.)

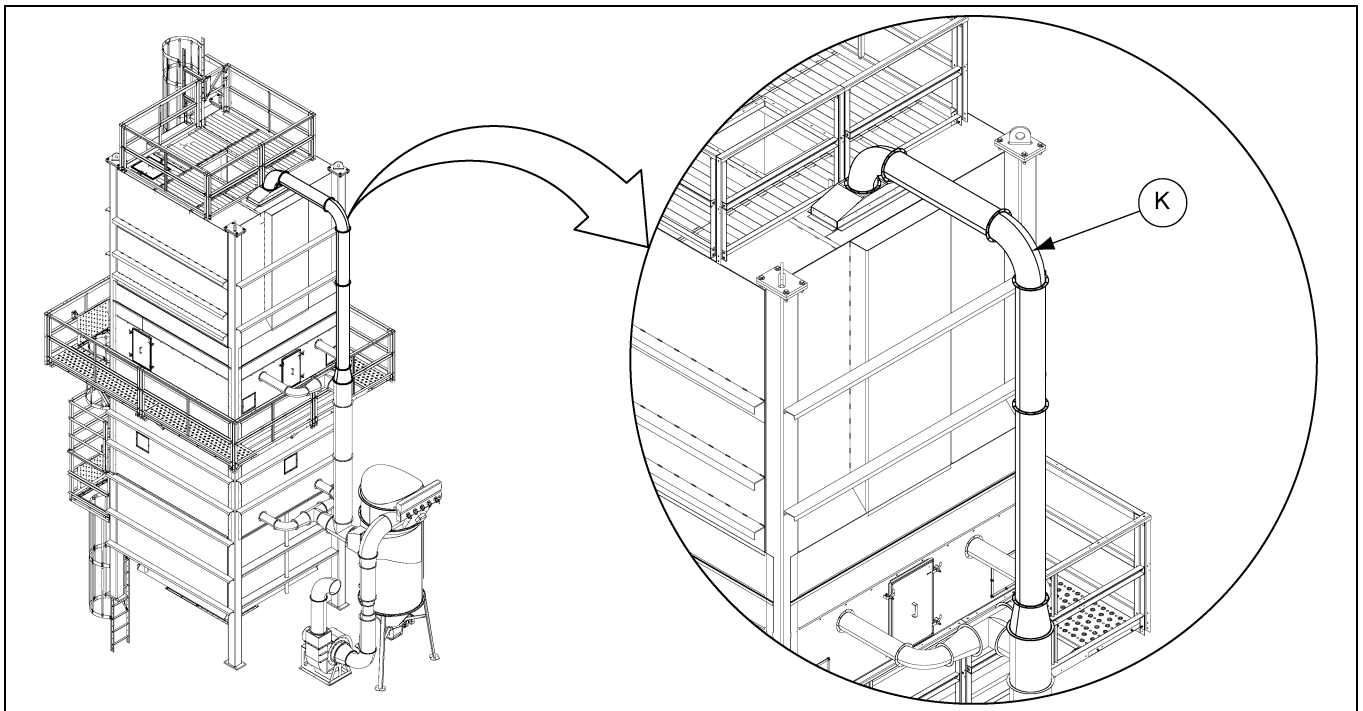

Figure 2O

Ref #	Description
K	Upper Garner Duct Section

5. Position the fan (M) and connect to the filter with the venturi duct section (L). (See Figure 2P.)

NOTE: The arrow on the venturi sections must point towards the fan.

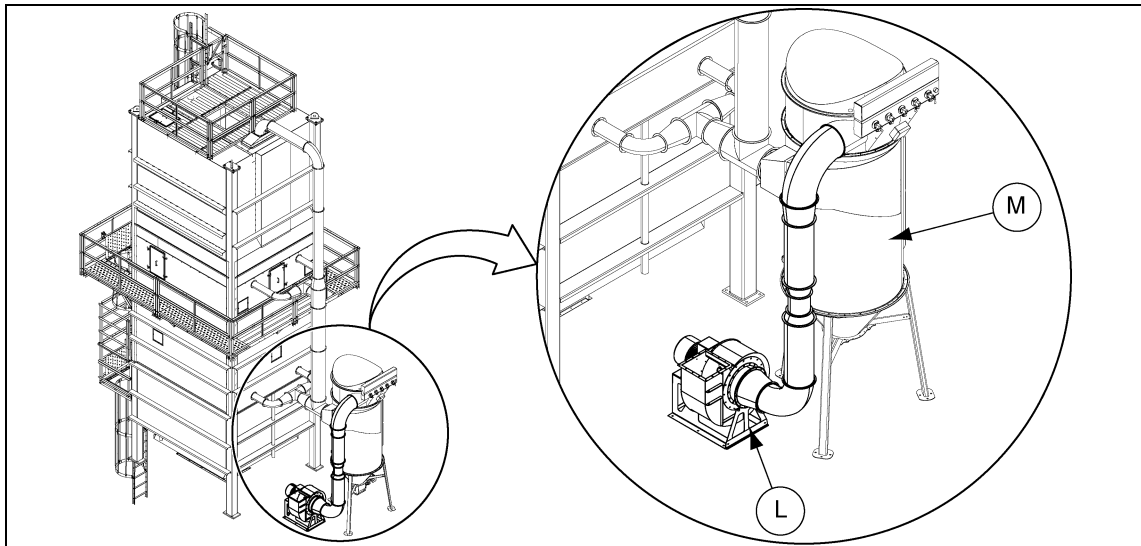

Figure 2P

Ref #	Description	Ref #	Description
L	Venturi Section	M	Fan

6. Attach any fan outlet duct (N). (See Figure 2Q.)

7. Anchor the fan (M) and filter when in their final positions.

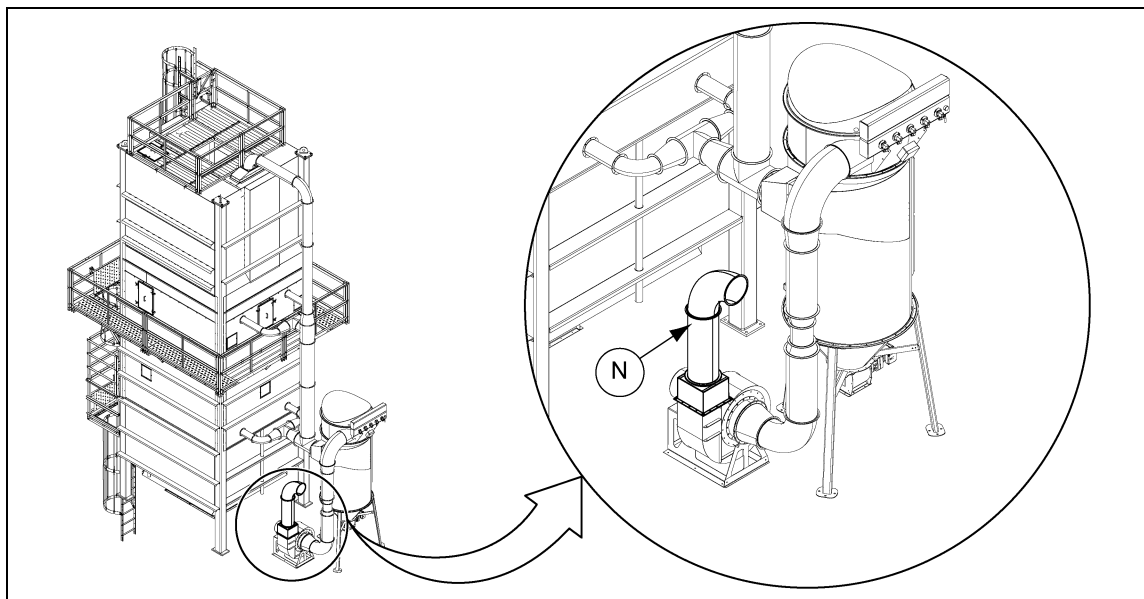

Figure 2Q

Ref #	Description
N	Fan Outlet Duct



The fan must be fitted with an outlet guard.

2. Installation

Installing the Load Cells

1. Refer to [See Figure 2X on Page 35](#) for load cell connections.
2. Mount the load cell junction box near the load cells (I).
3. Mount I/O box near the computer control in the control room.
4. Run a separate conduit from the J-box to the I/O box location.
5. Install the load cells (I) as follows.

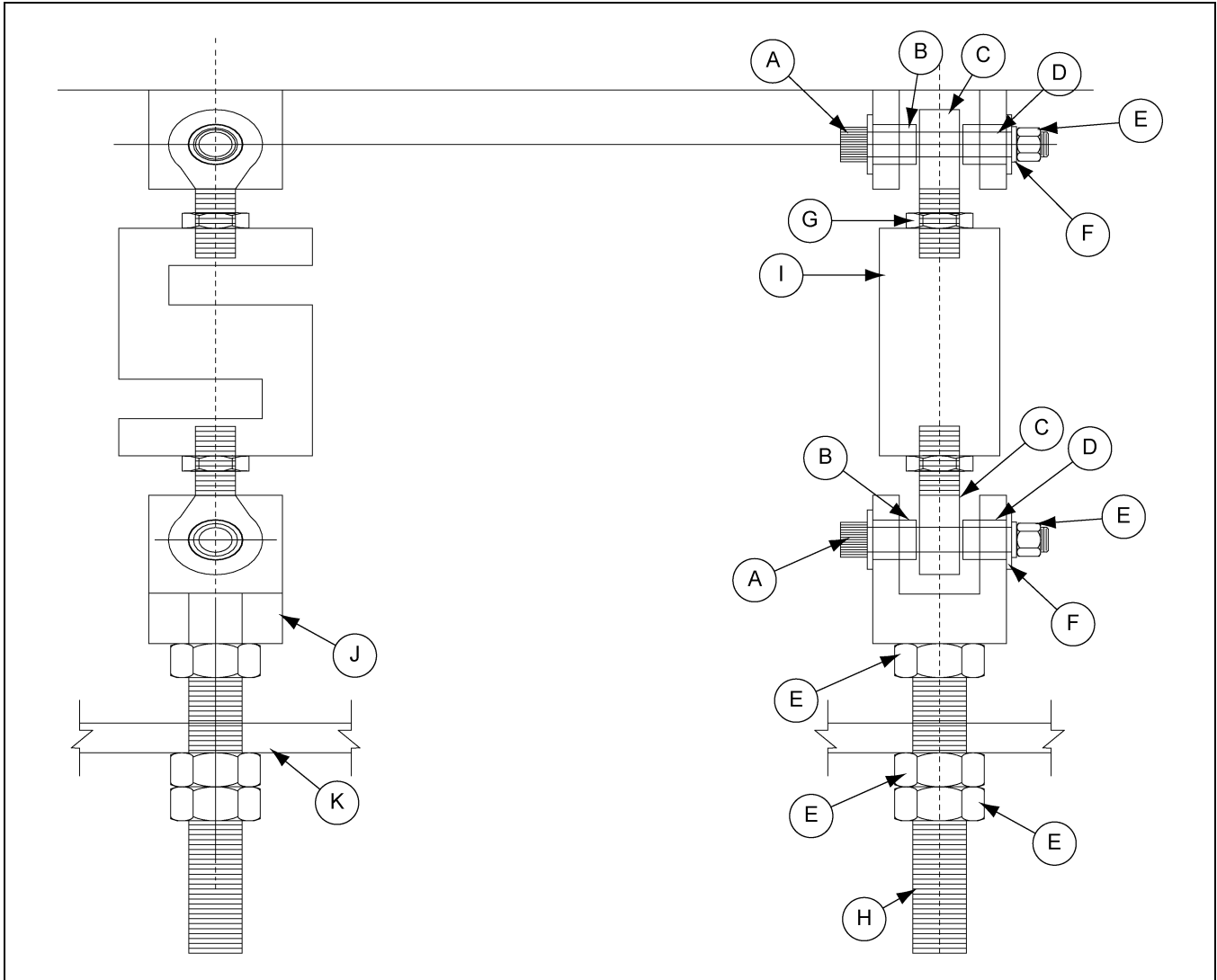

Figure 2R Load Cell Assembly

Ref #	Description
A	Stripper Bolt
B	Collar Bushing Four (4) Per Load Cell
C	Rod End Bearing
D	Flat Washers Two (2) Required Per Cell
E	Hex Nut
F	Lock Washer

Ref #	Description
G	Jam Nut
H	Threaded Rod
I	Load Cell
J	Clevis
K	Top of Weigh Hopper Load Cell Flange

- a. Hoist up the weigh hopper (keeping it level and properly aligned with the load cells) using a suitable lifting mechanism.
- b. Lift only high enough to install the load cells and avoid over stretching the flex connectors.
- c. Install the load cell with the hardware as shown in the load cell assembly.
(See [Figure 2R on Page 28.](#))
- d. Gently lower the weigh hopper until the load cells are supporting it.
- e. Run each load cell cable to the junction box. **NOTE:** *Do not cut off the excess cable and do not terminate the cable ends at this time.*
- f. Pull the home run load cell cable from the J-box to the digital indicator. Do not terminate the cable ends at this time.
- g. Connect the earth braid (L) between the upper and lower mounting positions. ([See Figure 2S.](#))

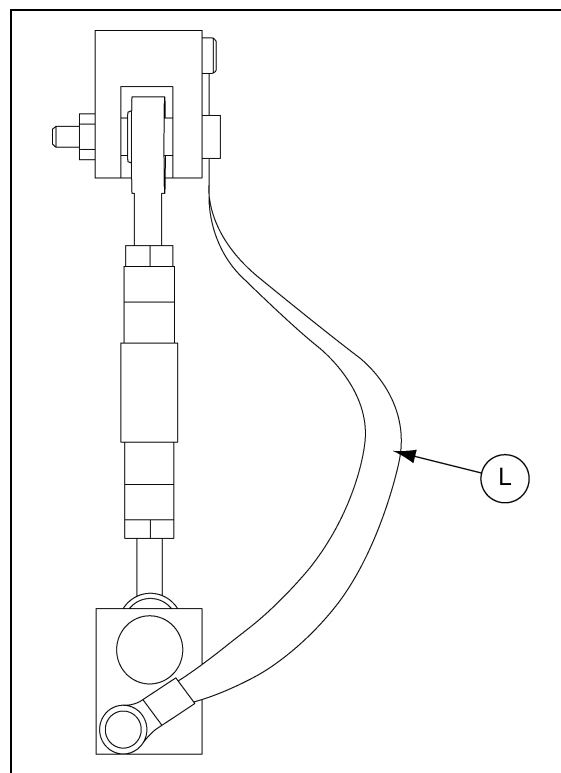

Figure 2S

Ref #	Description
L	Earth Braid

6. Hook-up the safety chains. The hopper must be free to settle, with the chains still loose, but if a load cell breaks minimum hopper fall is desired. So, let the safety chains hang loose, but not too loose.

2. Installation

7. Hook-up the test weight chains and the test weight lifters according to the test weight lift assembly drawing as shown in *Figure 2T*.

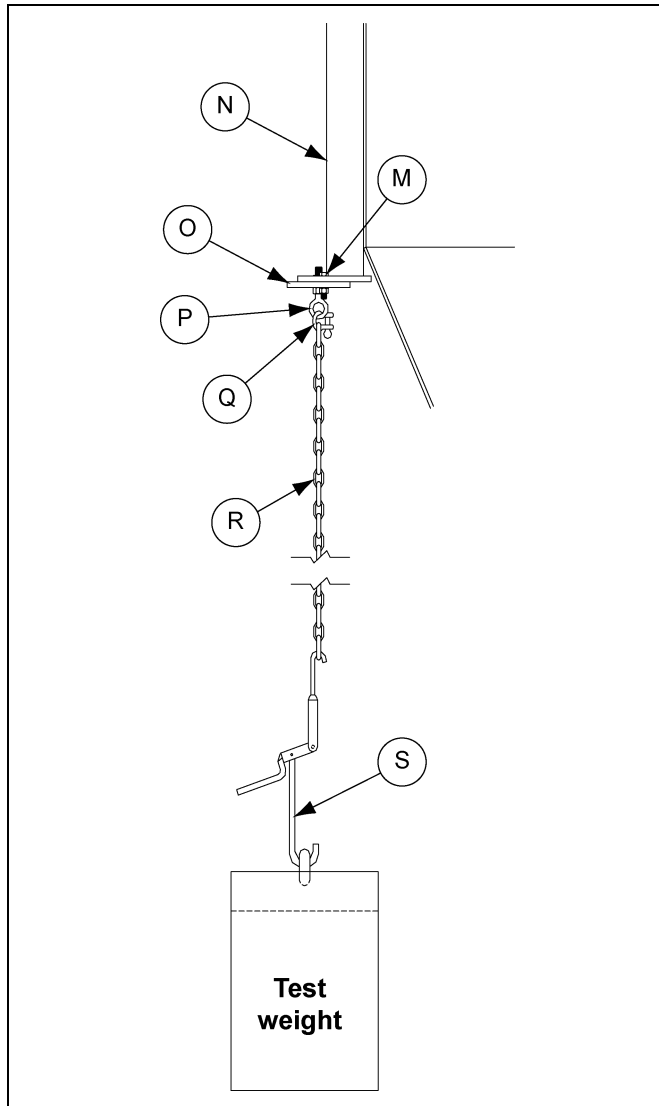

Figure 2T Test Weight Lift Assembly

Ref #	Description
M	Two (2) 1/2" bolts x 2" long required with nuts and lock washers for mounting the test weight adjustment plate.
N	Weigh Hopper Channel
O	Slotted test weight adjustment plate (523867). Adjust plate so the chain hangs clear of obstacles.
P	5/8 x 4" Long Forged Eye Bolt (35899). One nut on each side of adjustment plate.
Q	3/8" Chain Shackle (35173)
R	1/4" Chain Long (35174). Use only enough chain so it will hang almost tight when the test weight is down.
S	Chain Tightener (36916)

Electrical Connections

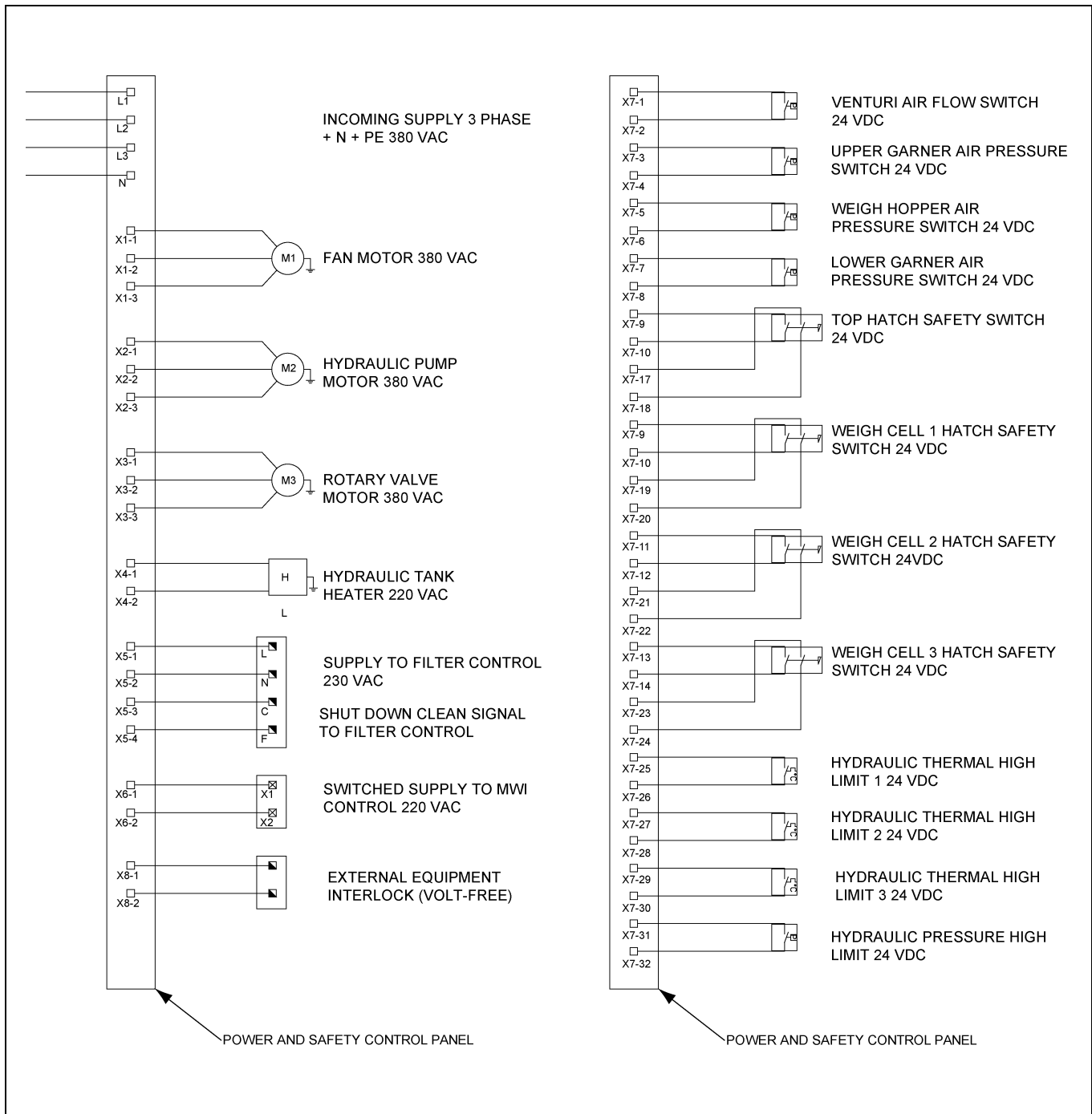

Figure 2U Power and Safety Panel Terminals

2. Installation

1. All electrical installation to be carried out and tested and certified in accordance with EN60204 and all local codes, standards and regulations.
2. A low impedance protective earth (PE) connection must be provided.
3. Make connections from the MWI controller.

a. Refer to bulk weigher electrical schematic and run conduit and wiring from the I/O box location to:

- Valve solenoids
- Limit switches
- Indicators level switches

All connections must run through ATEX compliant cable glands and/or conduit at both the component and junction box end.

b. Make connections, using crimp ferrules or terminals to contain wire strands.

c. Tighten all cable glands/apply resin to conduit type glands in accordance with manufacturer's instructions.

4. Make connections from Power and Safety Control.

a. Refer to [Figure 2U on Page 31](#) and make connections from the Power and Safety Panel to:

b. Venturi air flow switch (x 1). ([See Figure 1C on Page 15.](#)) Use 2 core + earth cable.

c. Air pressure switches (x 3). ([See Figure 1B on Page 15.](#)) Use 2 core + earth cable.

- Hydraulic thermal high limit switches (x 3), on hydraulic power pack. Use 2 core cable.
- Hydraulic high pressure limit switch (x 1), on hydraulic power pack. Use 2 core cable.

d. Service access panel safety switches (x 4). ([See Figure 2V on Page 33.](#)) Use 4 core + earth.

- i. **NOTE:** *All access panel safety switches must be connected to BOTH NC safety contacts.*
- ii. Use M20 ATEX certified cable glands for access panel switches.
- iii. Switch cable glands (M20) fit into the pre-formed holes on the door frames.
- iv. Wires to the switches run on the outside of the weigher.

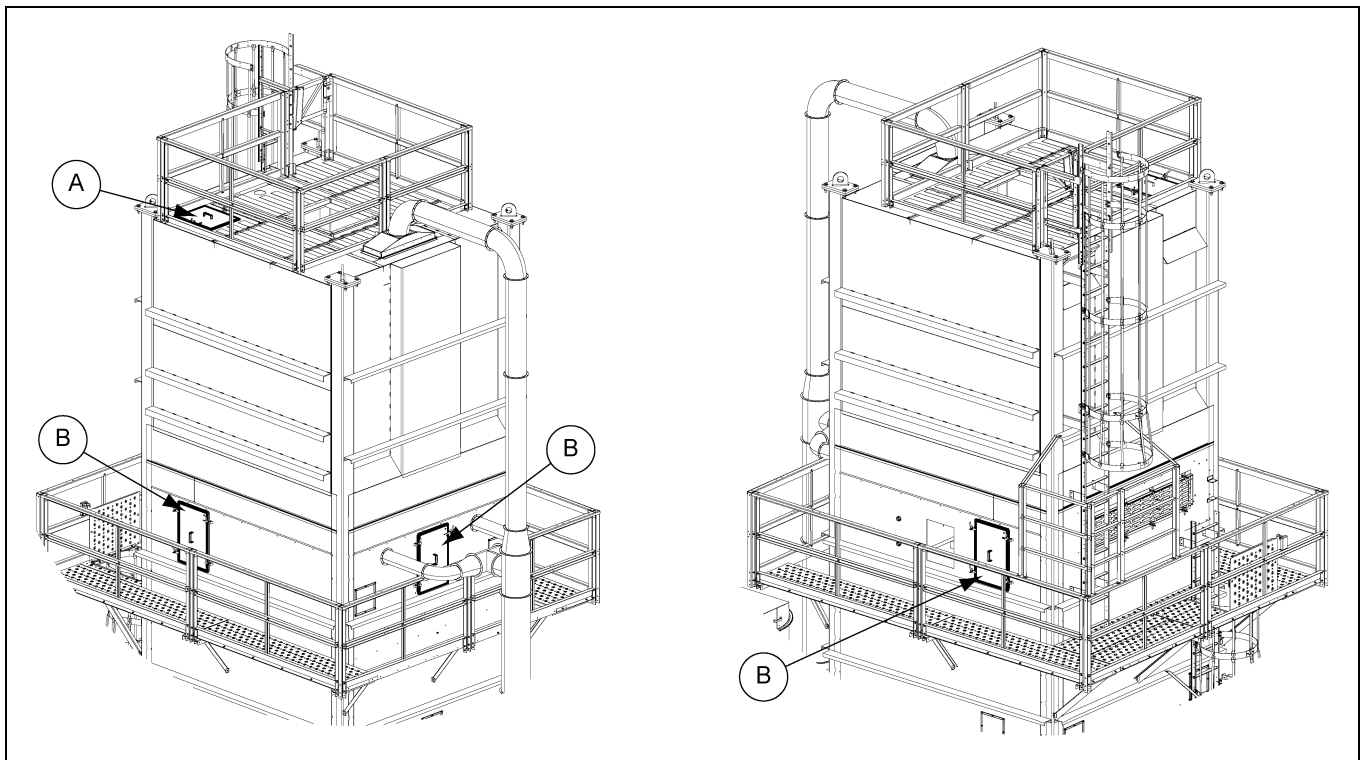

Figure 2V Service Access Panels

Ref #	Description
A	Upper Service Access Panel
B	Weigh Cell Service Access Panels

- Fan motor terminals (L1, L2, L3 and PE)
- Hydraulic motor terminals (L1, L2, L3 and PE)
- Rotary valve motor (on filter unit) (L1, L2, L3 and PE)
- Hydraulic tank heater (L, N and PE)
- MWI control supply terminals (X1, X2 and PE)
- Filter unit control supply terminals (L, N and PE)
- Filter unit control “shut down cleaning” terminals (C and F)







e. **NOTE:** Volt free contacts X8-1 and X8-2 are provided to enable external equipment to be interlocked to the safety circuits of the bulk weigher. This will allow for feed and discharge equipment to be safety stopped in the event that the bulk weigher experiences a safety issue, such as loss of airflow.

- f. Make connections using crimp ferrules or terminals to retain wire strands.
- g. Use suitable multi-core cables or steel conduit system and wires.
- h. Supply and install service disconnect switches as required, adjacent to all motors.
- i. Additional emergency stop switches may be added to the safety circuit as required.

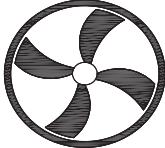
2. Installation

5. Incoming power shall be three phase and neutral, connected to the control disconnect switch on the Power and Safety control panel.
 - a. Refer to the rating plate on the inside of the power and safety control panel door for minimum power supply size. (See Figure 2W.)
 - b. Power supply to be from a separate, fused, switch isolator.

NOTE: The maximum fuse size and fuse type is given on the rating plate inside the door of the power and safety control panel. DO NOT exceed the current rating stated.

Bulk Weigher Control			
AGCO Grain and Protein			
A/S Cimbria, Faartoftvej 22, P.O. Box 40, 7700, Thisted, DENMARK			
SN #	250519SP		
Order #	280010113		
	380 V; 3~	11 kW	22.3 A
	380 V; 3~	7.5 kW	15.2 A
	380 V; 3~	0.4 kW	0.8 A
	220 V; 1~	0.75 kW	2.6 A
	Power supply	380 V AC	
		3 ~ 50 hz	
		FLA 40.9 A	
		Control 24 V DC	
		SCCR 13 kA	
		28 May 2019	
	<= 80A (aM)		

(C)

Figure 2W Bulk Weigher Control Rating Plate

Ref #	Description
C	Maximum Fuse Rating and Type

Load Cell Connections

Load cell connections are to be completed by a scale technician.

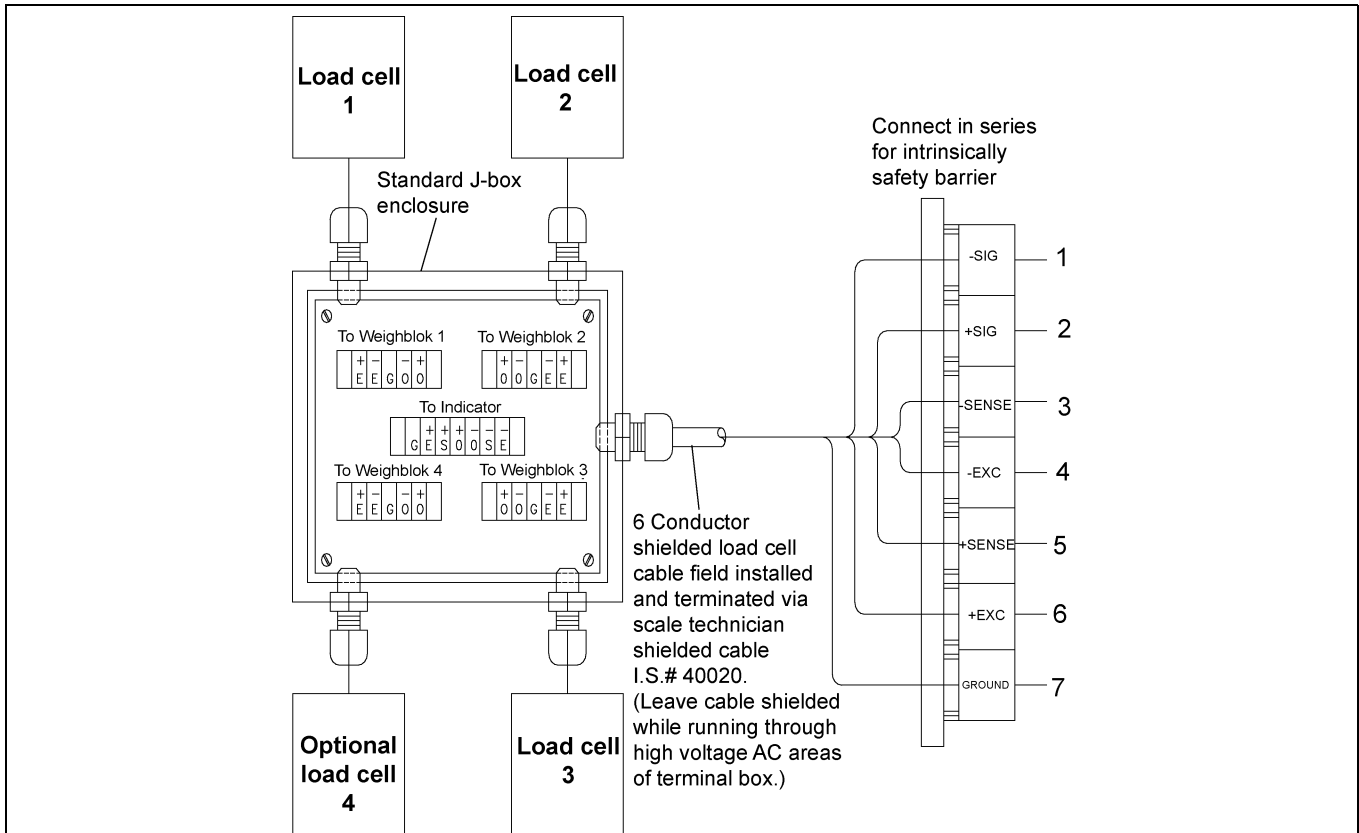

Multi-Cell Hook-Up

Load Cell Cable Identification		
Wire #	Electrical Function	Color Code
1	- Signal	White
2	+Signal	Green
3	-Sense	Blue
4	-Excitation	Black
5	+Sense	Yellow
6	+Excitation	Red
7	Ground	Shield

Single-Cell Hook-Up

Load Cell Cable Identification		
Wire #	Electrical Function	Color Code
1	- Signal	White
2	+Signal	Green
3	-Sense	Blue
4	-Excitation	Black
5	+Sense	Yellow
6	+Excitation	Red
7	Ground	Shield

Jumpers required

Load Cell Hook-Up Notes:

1. Up to four (4) load cells may be connected.
2. Maximum excitation voltage of 15 VDC.
3. Load cell cables should be of equal lengths.
4. Conduit runs to the junction box shall not contain any wiring other than load cell cables.
5. All grounding of J-box and load cells should meet local codes.
6. Load cell color coding must be maintained.
7. Maximum length for each conductor load cell cable = 11 m.
8. When using intrinsic safety barrier, refer to manufactures specifications.

Figure 2X Load Cell Termination Details

Commissioning

Setting the Air Pressure and Flow Switches

1. It is vital that the air pressure and flow switches are correctly set, according to the certified settings for your weigher. These values vary from weigher to weigher. Do not use any other values when setting the switches.
2. Switches are set by turning the dial on the switch to the required pressure.



Figure 3A Pressure Switch Setting Dial

Hydraulic System - Pre-Start

1. Set the hydraulic tank heater dial temperature setting to 70°F.
2. Fill the power unit with oil. (ISO 32 or comparable arctic blend for extremely cold areas.)
3. FOR UNIT WITH PRESSURE COMPENSATING PUMP FILL THE PUMP CASE WITH OIL. (Use the same oil as you put in the tank.) Failure to do this may result in premature pump failure.

Start-Up

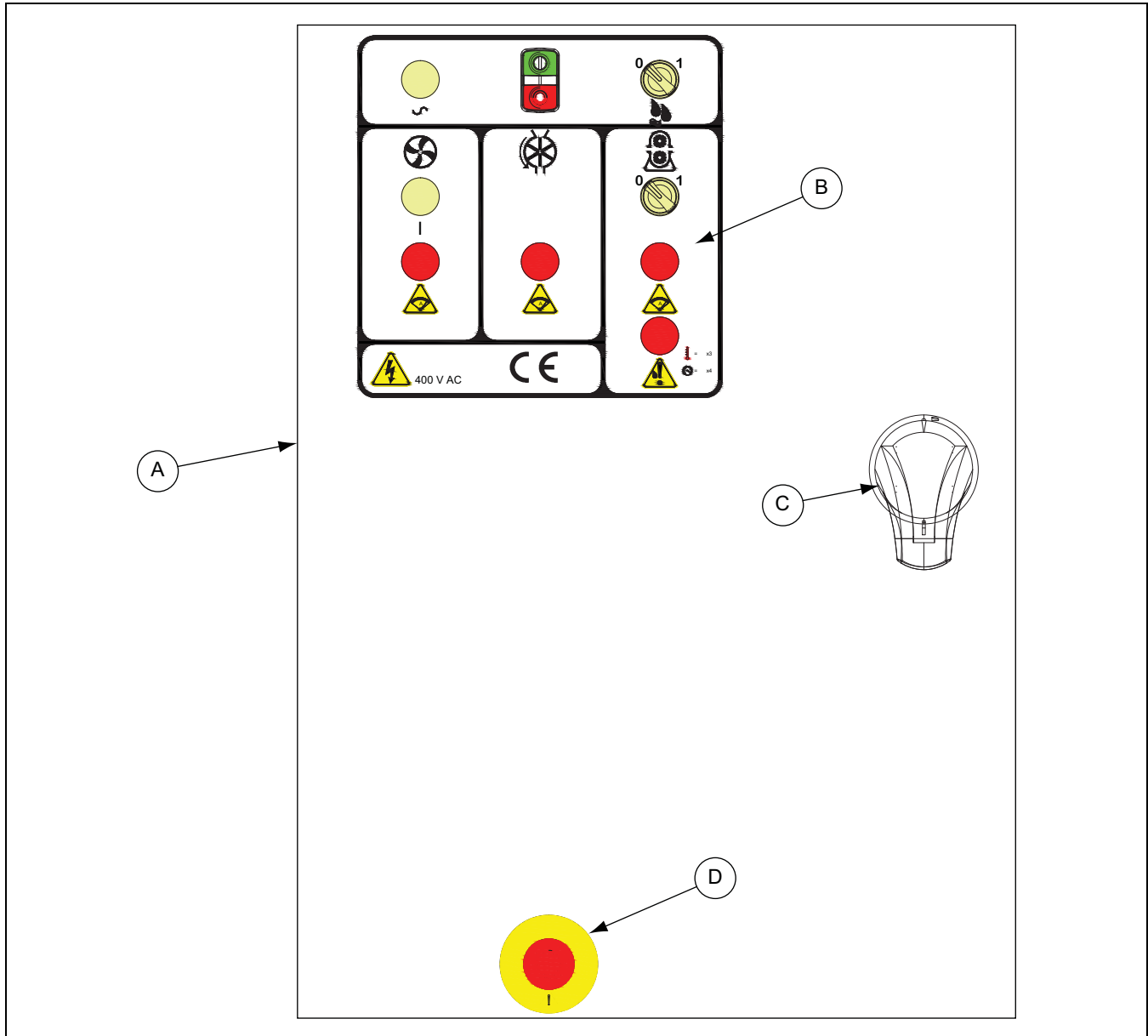

Figure 3B Power and Safety Panel

Ref #	Description
A	Enclosure
B	Control Legend

Ref #	Description
C	Isolator Switch
D	Emergency Stop

1. Apply power to the Power and Safety panel.
2. Check you have 380 VAC on all phases and 220 VAC from phase to neutral.
3. Pull out the emergency stop (D). *(See Figure 3B.)*
4. Check the hydraulic pump switch is OFF.
5. Check all door switches are closed and no-one is inside the weigher.
6. Turn the isolator switch (C) to ON. The power LED (E) should come ON. *(See Figure 3C on Page 38.)*

3. Operation

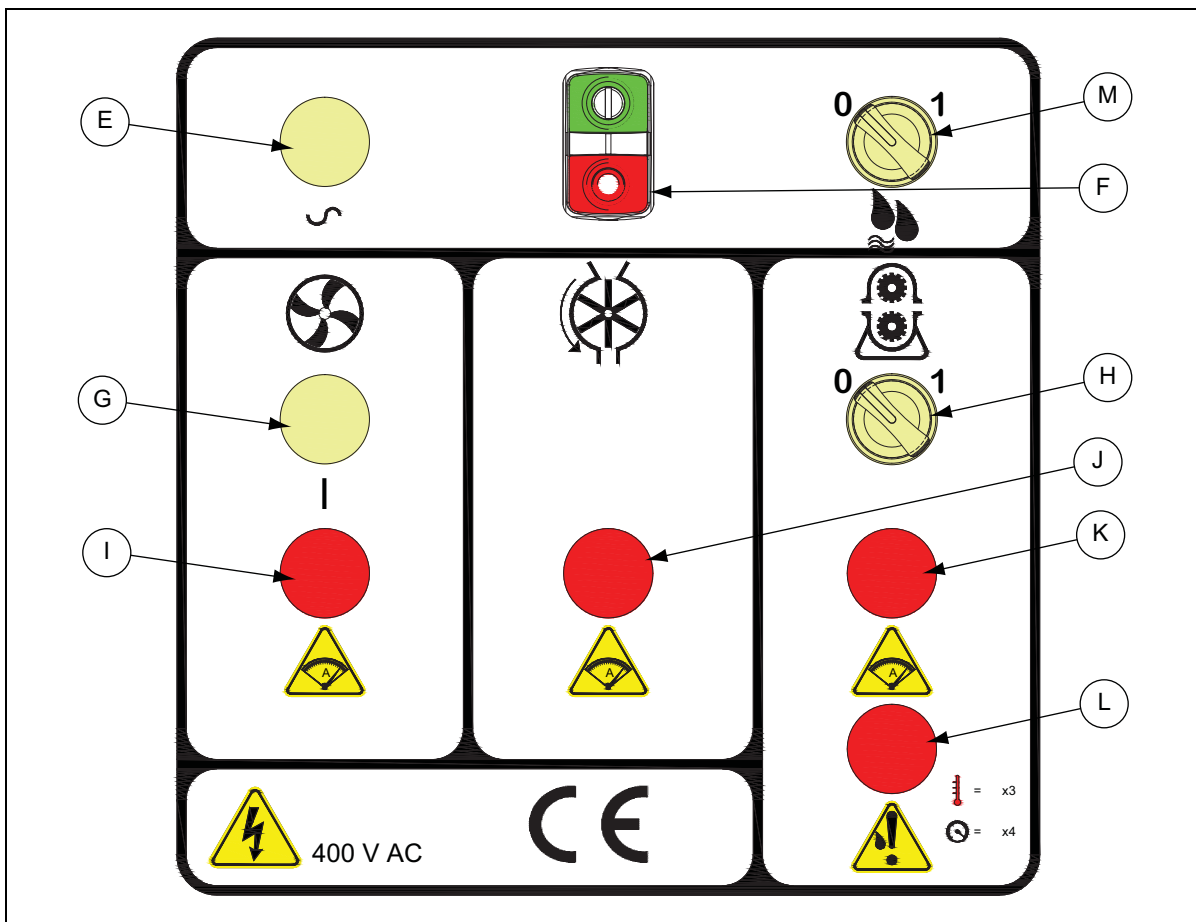

Figure 3C Control Legend

Ref #	Description
E	Power LED
F	Start/Stop Switch (with 24 VDC LED)
G	Fan Run/Status LED
H	Hydraulic Pump ON/OFF and LED
I	Fan Overload LED

Ref #	Description
J	Rotary Valve Overload LED
K	Hydraulic Pump Overload LED
L	Hydraulic System Fault LED
M	Hydraulic Oil Heater Switch

7. Press the start button (F). The 24 VDC LED (F) should come ON and the fan should start-up.
 - a. Check correct fan rotation direction and reverse if required.
8. At this stage, the fan run/status LED (G) should also come ON. This has 3 modes.
 - a. Steady 1 second flash = system purging.
 - b. 3 x flash = air switch not closing (air switch fault/insufficient airflow).
 - c. Steady on = purge complete, system running.
9. The correct sequence is a 60 second purge (a), followed by (c), at which point the hydraulic pump will start and the weigher control be activated.

10. In the event that the LED (G) signals “air switch not closing” (F):
 - a. If the fan is equipped with a speed control, VFD, the fan speed may be too low. This can only be adjusted by a qualified electrical technician. **NOTE:** *Maximum fan speed is achieved at VFD output of 50 Hz.*
 - b. If the fan speed is at maximum, check for correct duct connections and that the air inlets are not impeded.
 - c. Check correct air flow switch setting and connections.
 - d. Check correct air pressure switch settings and connections.
 - e. Check the venturi section is oriented in the correct direction relative to the air flow (it is marked with an airflow direction arrow).
11. When a steady light is achieved at the fan run/status LED (G), the extraction system is operating correctly.
12. Check hydraulic pump motor rotation. Quickly turn motor ON and OFF and verify the rotation is as indicated by the arrow on the pump. (Remove plastic cover on coupler to view rotation.)
13. Power unit pressure has been factory set, to 150-200 PSI. After oil has been circulated through the system, you will adjust the pressure to between 700-900 PSI. Pressure can be changed by screwing in or out the pressure relief valve cartridge. (See relief valve parts information.) For units with pressure compensating pump the adjustment is done on the hex nut on top side of the pump.
14. Make sure the ball valve is in open position so oil can flow through the system. Also make sure all the flow control valves are screwed out all the way to allow maximum flow.
15. Start up the power unit. Manually operate gates by pushing manual override on the end on the solenoid valves. This will start the oil circulating through the system. You may need to adjust the pressure in order to get the gates cylinders to move.
16. Check for leaks in fittings and bleed off air at a hydraulic air bleed valve. (Re-check oil level and fill as required.)
17. With all motors running, check the current on each phase and set the motor overload breakers inside the Power and Safety panel.
18. The weigher may now be operated. Refer to the weigher control manual.

Power and Safety Panel Fault Lights

Refer to control legend. ([See Figure 3C on Page 38.](#))

1. LED (I) is the fan overload warning. This will illuminate if the fan overload has tripped. (The fan will stop and the weigher shut down due to loss of air flow.)
2. LED (J) is the rotary valve overload warning. This will illuminate if the rotary valve motor overload has tripped. (The valve will stop but the weigher will continue to operate.)
3. LED (K) is the hydraulic pump motor overload warning. This will illuminate if the pump motor overload has tripped. (The pump will stop stopping the weigher.)
4. LED (L) is the hydraulic system fault light. This has 2 modes:
 - a. Sequence of 3 flashes indicates a hydraulic fluid over temperature fault. The weigher will shut down immediately, but the fan will perform a 60 second purge.
 - b. Sequence of 4 flashes indicates a hydraulic fluid over pressure fault. The weigher will shut down immediately, but the fan will perform a 60 second purge.

4. Maintenance



Always lock out and tag out the weigher from all electrical, pneumatic and hydraulic power before carrying out any maintenance.

Upon Receipt of Shipment



If the hydraulic system and the power unit will not be operated for more than three (3) months from delivery date, then do the following in order to avoid damage to the hydraulic components:

1. Fill the valves with oil after plugging all of the ports except for the one used for filling, then plug it after the valves have been filled.
2. Rotate the shaft on the electric motor every 90 days.
3. All of the cylinders are to be in their retracted position and then filled with oil and the ports plugged.
4. The tank needs to be filled to the top with oil after reaching the final destination to keep the inside of the tank from rusting.
5. Keep all components inside dry. (Do not cover with plastic to seal, this will have a tendency to attract moisture.)

Every Day

1. Stop the weigher at least once a day, but maintain power to the Power and Safety Panel. This will allow the dust filter to perform a “No-run clean”.
2. Check for signs of dust carry-over in the exhaust air from the fan. This might indicate a filter blockage.
3. Visually check that the air inlets to the weigher are kept clear and free flowing. Clean if necessary.

Every Six (6) Months

1. Check the hydraulic oil quality. (See hydraulic manual.)
 - a. Make sure it does not have a milky appearance from water contamination and does not contain particle contaminants such as rust.
 - b. If particle contaminants are found replace the oil and check again after one month of operation.
 - c. If contaminants are found again then check the hydraulic pump and hydraulic cylinders for faulty seals and check the tank and pipes for rusting. Replace all of the rusting components and faulty seals.
 - d. If water contamination is found, check all pipes and fittings, and check the tank for water leaks.
 - e. Make sure the cap was on the tank filler tightly. Replace any components which are faulty and refill the entire system with oil. If water is found again after a month of operation, consult IS.
2. Check hydraulic components for leaks.
 - a. Cylinders
 - b. Valves
 - c. Hoses
 - d. Fittings
 - e. Pump, etc.

3. If leaks are found, repair or replace component(s) which are faulty.
4. Check the following components for corrosion and make sure the housings are water-tight.
 - a. Valves
 - b. Material level indicators
 - c. Limit switches
 - d. Load cells
5. Check, clean or replace the hydraulic return line filter. *(See Figure 4A.)*
 - a. Stop the system's power unit
 - b. Relieve pressure in filter line
 - c. Rotate bowl (F) counterclockwise and remove.
 - d. Remove element (E) from housing. Discard all disposable elements. These elements are not cleanable.
 - e. Place new, clean element (E) in housing, centering it on location in the head (A).
 - f. Inspect bowl (G) seal and replace if necessary.
 - g. Replace bowl (F). Rotate clockwise and hand tighten.

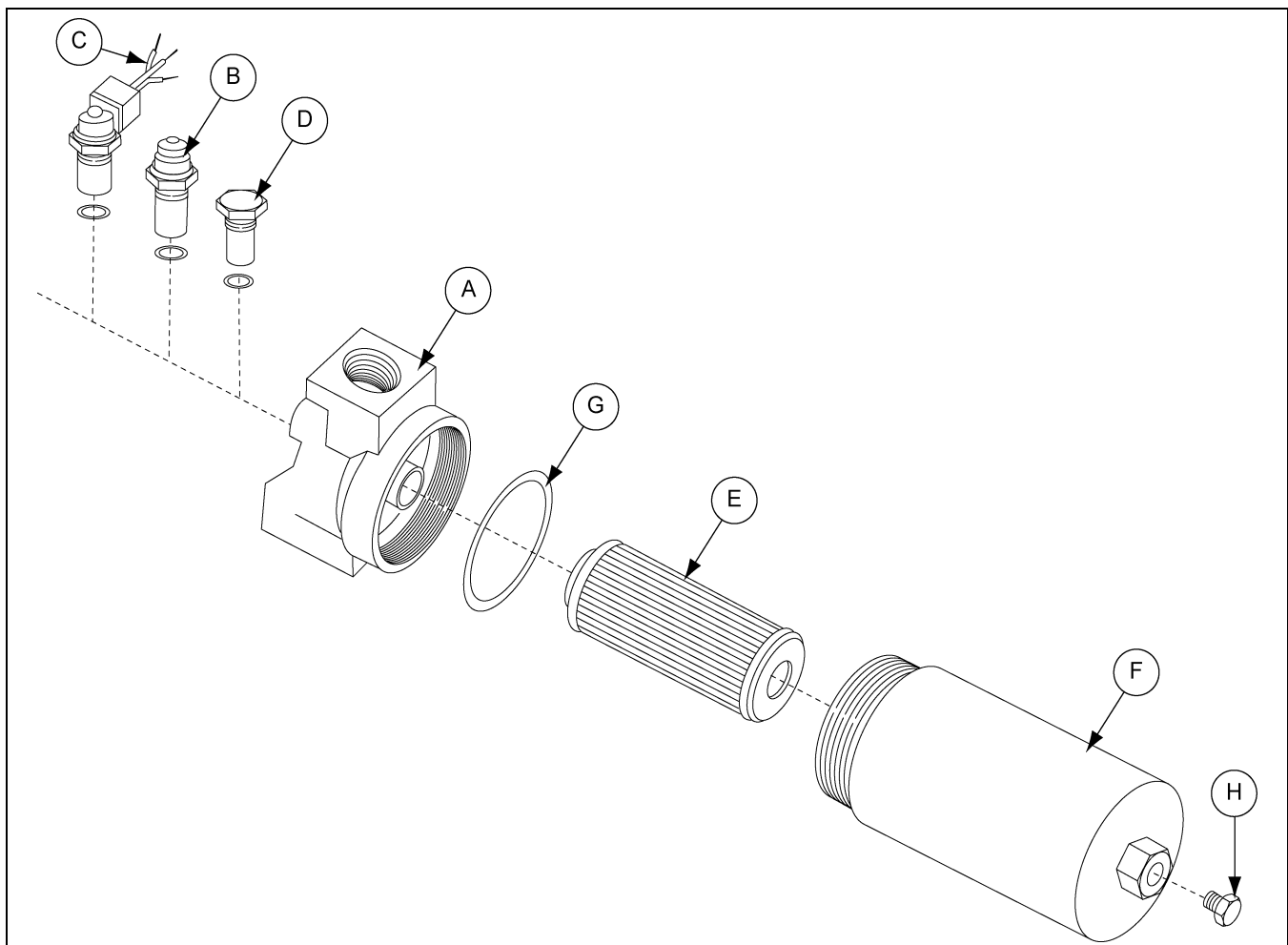

Figure 4A Return Line Filter

4. Maintenance

Parts List

Index	15CN	40CN	80CN	Description
A				Head
	929385	N/A	N/A	3/4" NPT with Bypass or Indicator
	929398	N/A	N/A	3/4" NPT no Bypass or Indicator
	929383	N/A	N/A	SAE-12 with Bypass or Indicator
	929396	N/A	N/A	SAE-12 no Bypass or Indicator
	929384	929547	N/A	1" NPT with Bypass or Indicator
	929397	929555	N/A	1" NPT no Bypass or Indicator
	929382	929545	N/A	SAE-16 with Bypass or Indicator
	929395	929553	N/A	SAE-16 no Bypass or Indicator
	N/A	929546	929633	1-1/2" NPT with Bypass or Indicator
	N/A	929554	929637	1-1/2" NPT no Bypass or Indicator
	N/A	929544	929645	SAE-24 with Bypass or Indicator
	N/A	929552	929649	SAE-24 no Bypass or Indicator
	N/A	N/A	929635	2" NPT with Bypass or Indicator
	N/A	N/A	929639	2" NPT no Bypass or Indicator
	N/A	N/A	929647	SAE-32 with Bypass or Indicator
	N/A	N/A	929651	SAE-32 no Bypass or Indicator
	N/A	N/A	929656	Flange Face, SAE 2" with Bypass or Indicator
	N/A	N/A	929660	Flange Face, SAE 2" no Bypass or Indicator
				Indicator Bypass Assemblies
				*Consult Factory for no Bypass Assemblies
B	932031	932038	932038	M2-Visual Auto Reset/25 PSI
	931706	932039	932039	M2-Visual Auto Reset/50 PSI
C	929962	930036	930036	E-Electrical/25 PSI with Conduit Connection
	929972	930038	930038	E-Electrical/50 PSI with Conduit Connection
	929963	930040	930040	E1-Electrical/25 PSI with Wire Leads
	929973	930042	930042	E1-Electrical/50 PSI with Wire Leads
	929964	930052	930052	E2-Electrical/25 PSI with Din Connection
	929974	930054	930054	E2-Electrical/50 PSI with Din Connection
	929965	930048	930048	E3-Electrical/25 PSI with 3-Pin Connection
	929975	930050	930050	E3-Electrical/50 PSI with 3-Pin Connection
D	930521	929846	929846	No Indicator/25 PSI Bypass
	930523	929848	929848	No Indicator/50 PSI Bypass
E				Element (See model code page)
F				Bowl
	929281	933359	933396	Single Length without Drain
	929282	933360	933397	Double Length without Drain
	932052	933361	933398	Single Length with Drain
	932056	933362	933399	Double Length with Drain
G				Bowl Seal
	N72143	N72240	N72246	Buna N (Nitrile)
	V72143	V72240	V72246	Viton
H				Drain Plug - SAE-4
	921088	921088	921088	Buna N (Nitrile)
	928882	928882	928882	Viton

6. Carry out a full check on the safety functions:
 - a. Operate emergency stops.
 - b. Operate access panel safety switches.
 - c. Check the air flow switch.
 - Remove the air connection tube from the push fit connector on the venturi.

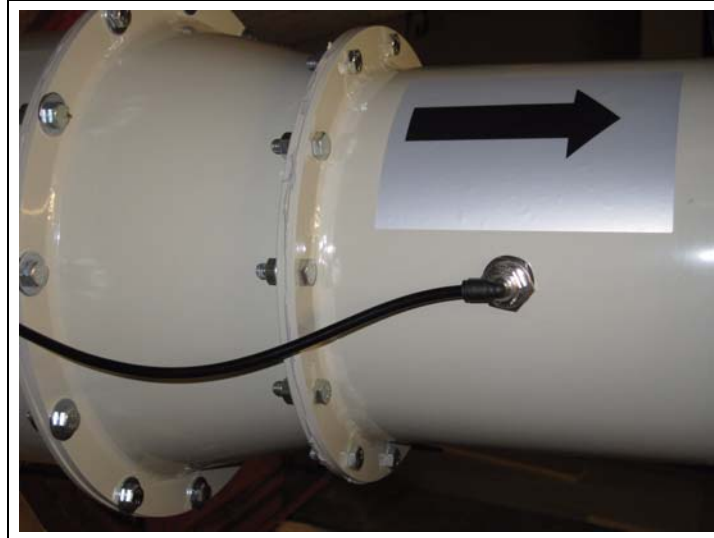

Figure 4B

- Start the fan.
 - The fan run/status indicator LED should go to a 3 x flash sequence, indicating that the air switch is not closing
 - Replace the air connection tube.
 - The LED should now go into a steady one second flash mode as the system goes into it's purge sequence.
 - Repeat this for all three of the static pressure switches.
7. If any of the safety function checks fail, the weigher must be serviced by GSI/InterSystems or their approved representative.
 8. NEVER bypass the safety features.

Every Twelve (12) Months

1. Check the lining and walls of the hopper for high wear areas. Replace or add liners where necessary.
2. Check the conduit, terminal boxes, and wiring for corrosion, bad wires, and or other damage.
3. Check the safety chain assemblies and the test weight chain for any damage.
4. Get the test weight certification renewed.
5. Check the welds on the scale for any cracks or damage.
6. Check the bolts and fittings for damage and function.
7. Check the paint quality and identify any areas of corrosion. Repaint as necessary.

Gate Malfunctions

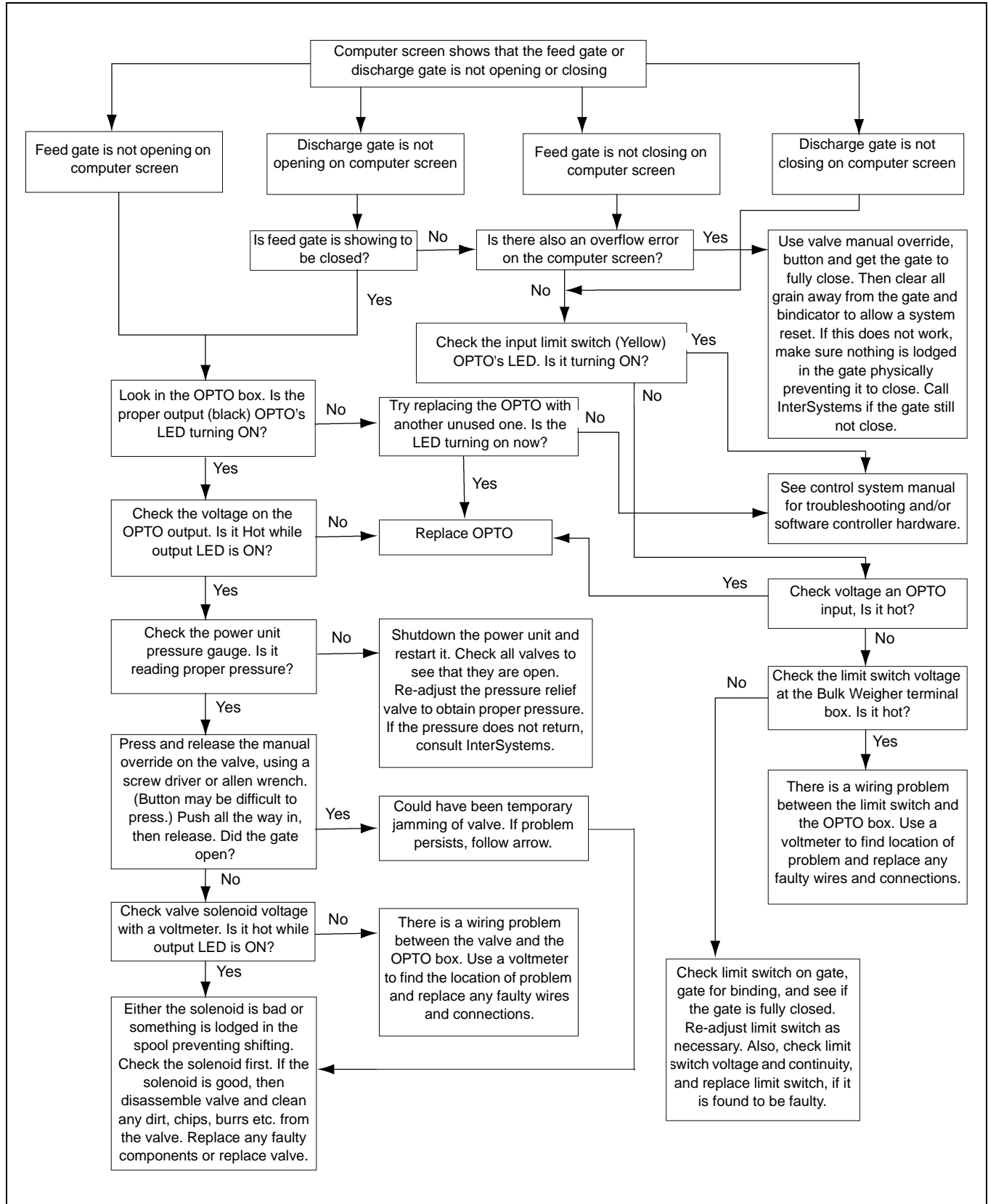

Figure 5A Troubleshooting Guide

Series 2H Heavy Duty Hydraulic Cylinder Parts

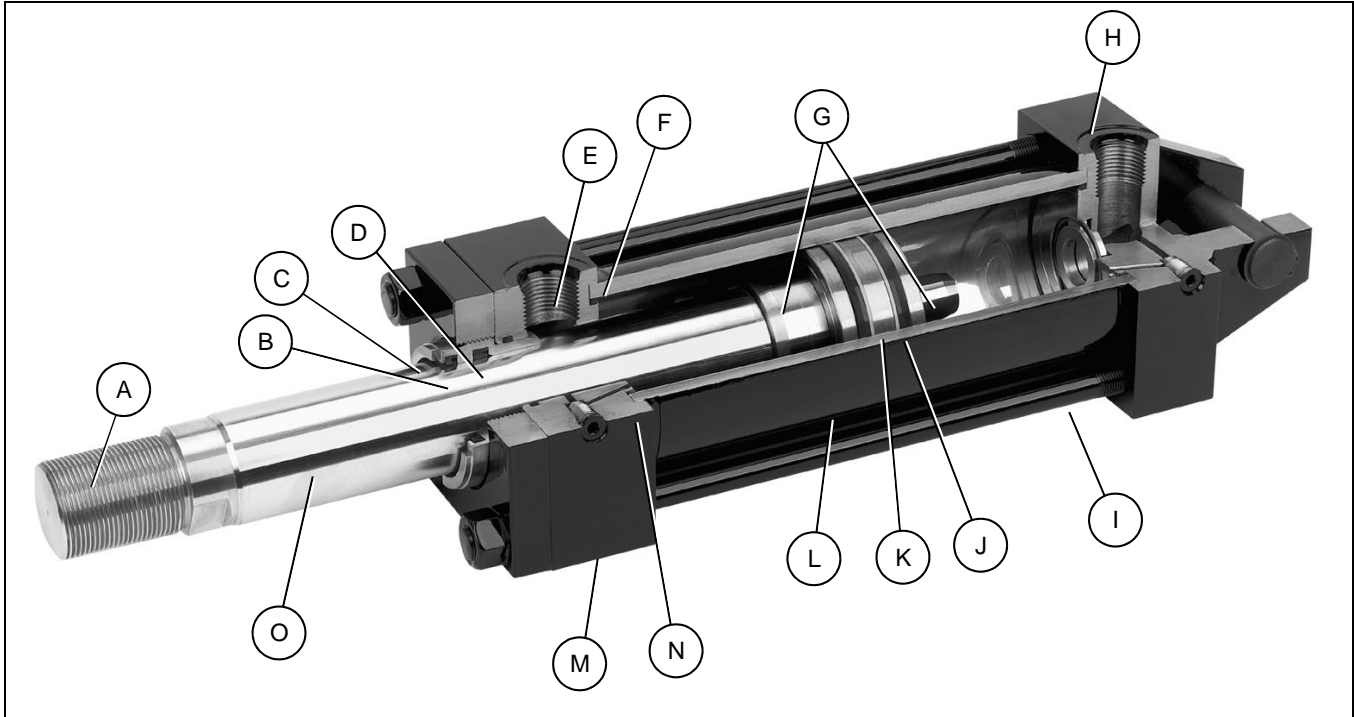

Figure 6A Hydraulic Cylinder Internal View

Ref #	Description
A	Piston Rod Stud
B	Secondary Seal
C	"Jewel" Rod Gland Assembly
D	Primary Seal
E	Ports
F	Align-A-Groove
G	Adjustable Floating Stepped Cushions
H	Steel Cap
I	High Strength Tie Rods
J	Lipseal™ Piston
K	One-Piece Nodular Iron Piston
L	Cylinder Body
M	Steel Head
N	End Seals
O	Piston Rod

NOTE: For additional information - Call your local Parker Fluidpower Motion and Control Distributor.

6. Bulk Weigher Parts Information

Rectangular Flange and Head Mountings - 1-1/2" to 6" Bore Sizes

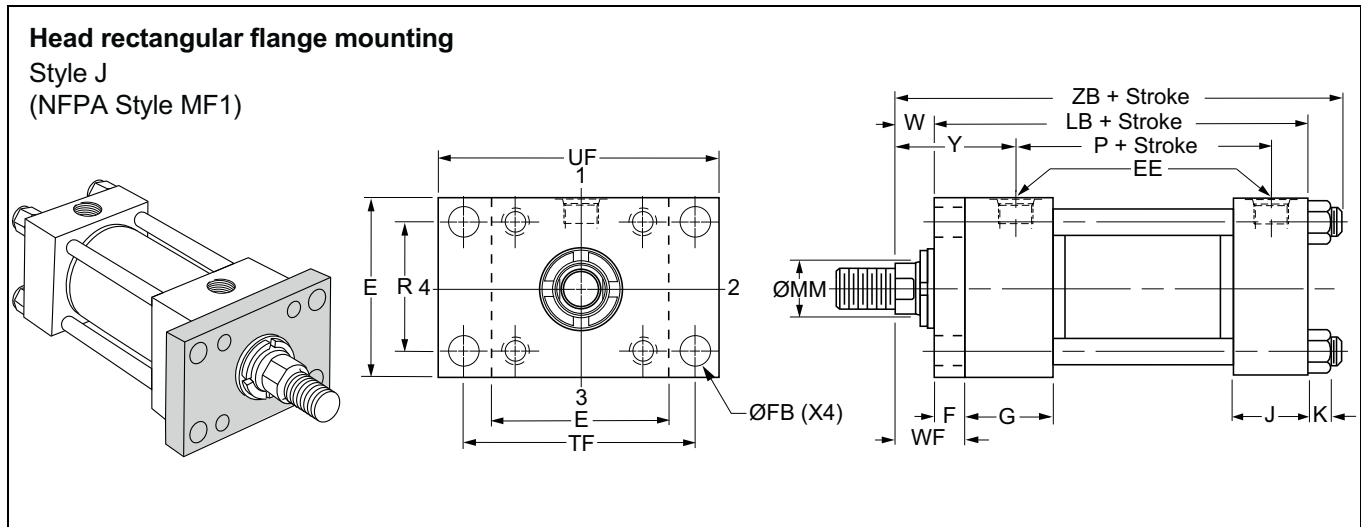

Figure 6B Head Rectangular Flange Mounting - Style J

Style J – Dimensional and Mounting Data

Bore Ø	E	EE		F	FB Ø	G	J	K	R	TF	UF	Add Stroke	
		NPTF ¹	SAE ²									LB	P
1.50	2.50	1/2	10	0.38	0.44	1.75	1.50	0.38	1.63	3.44	4.25	5.00	2.88
2.00	3.00	1/2	10	0.63	0.56	1.75	1.50	0.44	2.05	4.13	5.13	5.25	2.88
2.50	3.50	1/2	10	0.63	0.56	1.75	1.50	0.44	2.55	4.63	5.63	5.38	3.00
3.25	4.50	3/4	12	0.75	0.69	2.00	1.75	0.56	3.25	5.88	7.13	6.25	3.50
4.00	5.00	3/4	12	0.88	0.69	2.00	1.75	0.56	3.82	6.38	7.63	6.63	3.75
5.00	6.50	3/4	12	0.88	0.94	2.00	1.75	0.81	4.95	8.19	9.75	7.13	4.25
6.00	7.50	1	16	1.00	1.06	2.25	2.25	0.88	5.73	9.44	11.25	8.38	4.88

¹ NPTF ports are available at no extra charge.

² SAE straight thread ports are standard and are indicated by port number.

NOTE: For additional information - Call your local Parker Fluidpower Motion and Control Distributor.

6. Bulk Weigher Parts Information

Style J – Dimensional and Mounting Data

Bore Ø	Rod No.	MM Rod Ø	W	WF	Y	Add Stroke
						ZB Maximum
1.50	1 (std.)	0.625	0.63	1.00	2.00	6.25
	2	1.000	1.00	1.38	2.38	6.63
2.00	1 (std.)	1.000	0.75	1.38	2.38	6.69
	2	1.375	1.00	1.63	2.63	6.94
2.50	1 (std.)	1.000	0.75	1.38	2.38	6.81
	2	1.750	1.25	1.88	2.88	7.31
	3	1.375	1.00	1.63	2.63	7.06
3.25	1 (std.)	1.375	0.88	1.63	2.75	7.94
	2	2.000	1.25	2.00	3.13	8.31
	3	1.750	1.13	1.88	3.00	8.19
4.00	1 (std.)	1.750	1.00	1.88	3.00	8.50
	2	2.500	1.38	2.25	3.38	8.88
	3	2.000	1.13	2.00	3.13	8.63
5.00	1 (std.)	2.000	1.13	2.00	3.13	9.38
	2	3.500	1.38	2.25	3.38	9.63
	3	2.500	1.38	2.25	3.38	9.63
	4	3.000	1.38	2.25	3.38	9.63
6.00	1 (std.)	2.500	1.25	2.25	3.50	10.81
	2	4.000	1.25	2.25	3.50	10.81
	3	3.000	1.25	2.25	3.50	10.81
	4	3.500	1.25	2.25	3.50	10.81

Style J – Maximum Operating Pressure/2H

Bore Ø	Maximum PSI Push ³			
	Rod Code			
	1	2	3	4
1.50	1500	1000	-	-
2.00	2000	1200	-	-
2.50	2000	1100	1500	-
3.25	1800	1300	1400	-
4.00	1800	1300	1700	-
5.00	1300	800	1200	1000
6.00	1200	800	1000	900

Style J – Maximum Operating Pressure/2HD

Bore Ø	Maximum PSI Push ³			
	Rod Code			
	1	2	3	4
1.50	1400	1000	-	-
2.00	2000	1200	-	-
2.50	700	1000	700	-
3.25	800	600	800	-
4.00	1000	700	1000	-
5.00	850	800	850	450
6.00	650	400	650	400

³ Maximum Pressure Rating – Push Application.

NOTE: For additional information - Call your local Parker Fluidpower Motion and Control Distributor.

6. Bulk Weigher Parts Information

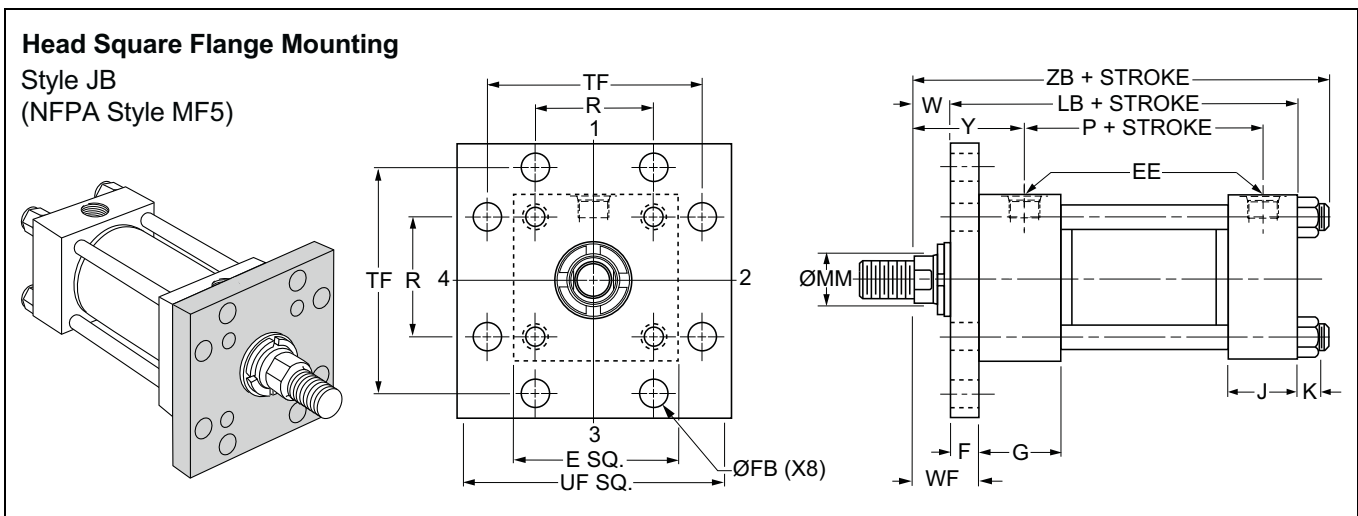

Figure 6C Head Square Flange Mounting - Style JB

Style JB – Dimensional and Mounting Data

Bore Ø	E	EE		F	FB Ø	G	J	K	R	TF	UF	Add Stroke	
		NPTF ¹	SAE ²									LB	P
1.50	2.50	1/2	10	0.38	0.44	1.75	1.50	0.38	1.63	3.44	4.25	5.00	2.88
2.00	3.00	1/2	10	0.63	0.56	1.75	1.50	0.44	2.05	4.13	5.13	5.25	2.88
2.50	3.50	1/2	10	0.63	0.56	1.75	1.50	0.44	2.55	4.63	5.63	5.38	3.00
3.25	4.50	3/4	12	0.75	0.69	2.00	1.75	0.56	3.25	5.88	7.13	6.25	3.50
4.00	5.00	3/4	12	0.88	0.69	2.00	1.75	0.56	3.82	6.38	7.63	6.63	3.75
5.00	6.50	3/4	12	0.88	0.94	2.00	1.75	0.81	4.95	8.19	9.75	7.13	4.25
6.00	7.50	1	16	1.00	1.06	2.25	2.25	0.88	5.73	9.44	11.25	8.38	4.88

¹ NPTF ports are available at no extra charge.

² SAE straight thread ports are standard and are indicated by port number.

NOTE: For additional information - Call your local Parker Fluidpower Motion and Control Distributor.

6. Bulk Weigher Parts Information

Style JB – Dimensional and Mounting Data

Bore Ø	Rod No.	MM Rod Ø	W	WF	Y	Add Stroke
						ZB Maximum
1.50	1 (std.)	0.625	0.63	1.00	2.00	6.25
	2	1.000	1.00	1.38	2.38	6.63
2.00	1 (std.)	1.000	0.75	1.38	2.38	6.69
	2	1.375	1.00	1.63	2.63	6.94
2.50	1 (std.)	1.000	0.75	1.38	2.38	6.81
	2	1.750	1.25	1.88	2.88	7.31
	3	1.375	1.00	1.63	2.63	7.06
3.25	1 (std.)	1.375	0.88	1.63	2.75	7.94
	2	2.000	1.25	2.00	3.13	8.31
	3	1.750	1.13	1.88	3.00	8.19
4.00	1 (std.)	1.750	1.00	1.88	3.00	8.50
	2	2.500	1.38	2.25	3.38	8.88
	3	2.000	1.13	2.00	3.13	8.63
5.00	1 (std.)	2.000	1.13	2.00	3.13	9.38
	2	3.500	1.38	2.25	3.38	9.63
	3	2.500	1.38	2.25	3.38	9.63
	4	3.000	1.38	2.25	3.38	9.63
6.00	1 (std.)	2.500	1.25	2.25	3.50	10.81
	2	4.000	1.25	2.25	3.50	10.81
	3	3.000	1.25	2.25	3.50	10.81
	4	3.500	1.25	2.25	3.50	10.81

Style JB – Maximum Operating Pressure/2H

Bore Ø	Maximum PSI Push ³			
	Rod Code			
	1	2	3	4
1.50	3000	3000	-	-
2.00	3000	3000	-	-
2.50	3000	3000	3000	-
3.25	3000	3000	3000	-
4.00	3000	3000	3000	-
5.00	3000	3000	3000	3000
6.00	3000	2700	3000	2700

Style JB – Maximum Operating Pressure/2HD

Bore Ø	Maximum PSI Push ³			
	Rod Code			
	1	2	3	4
1.50	3000	3000	-	-
2.00	3000	3000	-	-
2.50	3000	3000	3000	-
3.25	3000	3000	3000	-
4.00	3000	3000	3000	-
5.00	2500	2300	2500	1800
6.00	2000	1600	2000	1600

³ Maximum Pressure Rating – Push Application.

NOTE: For additional information - Call your local Parker Fluidpower Motion and Control Distributor.

6. Bulk Weigher Parts Information

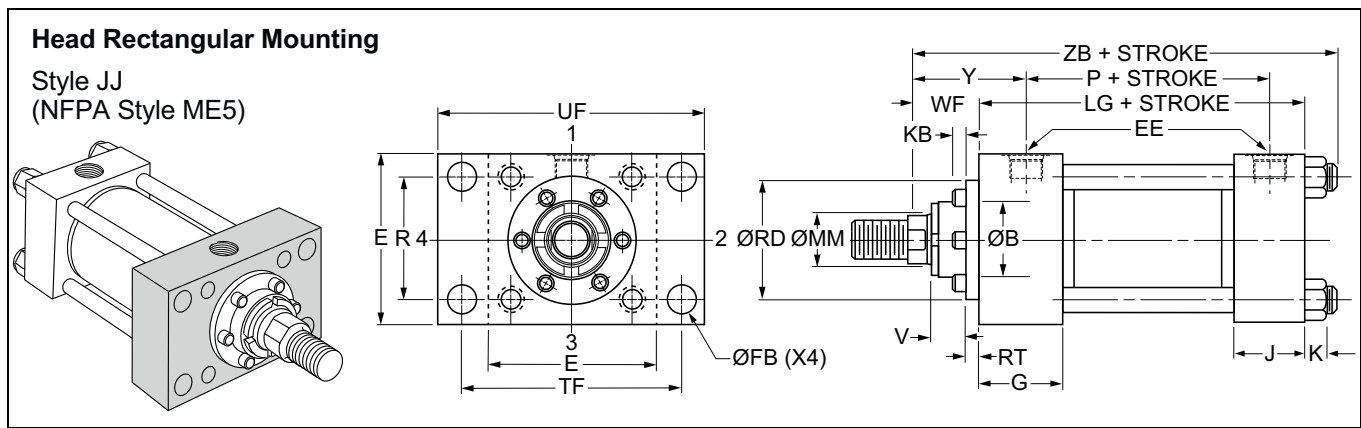

Figure 6D Head Rectangular Mounting - Style JJ

Style JJ – Dimensional and Mounting Data

Bore Ø	E	EE		FB Ø	G	J	K	R	TF	UF	Add Stroke	
		NPTF ¹	SAE ²								LG	P
1.50	2.50	1/2	10	0.44	1.75	1.50	0.38	1.63	3.44	4.25	4.63	2.88
2.00	3.00	1/2	10	0.56	1.75	1.50	0.44	2.05	4.13	5.13	4.63	2.88
2.50	3.50	1/2	10	0.56	1.75	1.50	0.44	2.55	4.63	5.63	4.75	3.00
3.25	4.50	3/4	12	0.69	2.00	1.75	0.56	3.25	5.88	7.13	5.50	3.50
4.00	5.00	3/4	12	0.69	2.00	1.75	0.56	3.82	6.38	7.63	5.75	3.75
5.00	6.50	3/4	12	0.94	2.00	1.75	0.81	4.95	8.19	9.75	6.25	4.25
6.00	7.50	1	16	1.06	2.25	2.25	0.88	5.73	9.44	11.25	7.38	4.88

¹ NPTF ports are available at no extra charge.

² SAE straight thread ports are standard and are indicated by port number.

NOTE: For additional information - Call your local Parker Fluidpower Motion and Control Distributor.

6. Bulk Weigher Parts Information

Style JJ – Dimensional and Mounting Data

Bore Ø	Rod No.	MM Rod Ø	B Ø +.000 -.002	KB	RD Ø	RT	V	WF	Y	Add Stroke
										ZB Maximum
1.50	1 (std.)	0.625	1.124	-	2.13	0.38	0.25	1.00	2.00	6.25
	2	1.000	1.499	-	2.50	0.38	0.50	1.38	2.38	6.63
2.00	1 (std.)	1.000	1.499	-	2.50	0.38	0.50	1.38	2.38	6.69
	2	1.375	1.999	0.25	3.00	0.38	0.63	1.63	2.63	6.94
2.50	1 (std.)	1.000	1.499	-	2.50	0.38	0.50	1.38	2.38	6.81
	2	1.750	2.374	0.25	3.50	0.38	0.75	1.88	2.88	7.31
	3	1.375	1.999	0.25	3.00	0.38	0.63	1.63	2.63	7.06
3.25	1 (std.)	1.375	1.999	0.25	3.00	0.38	0.63	1.63	2.75	7.94
	2	2.000	2.624	0.13	4.00	0.63	0.50	2.00	3.13	8.31
	3	1.750	2.374	0.25	3.50	0.38	0.75	1.88	3.00	8.19
4.00	1 (std.)	1.750	2.374	0.25	3.50	0.38	0.75	1.88	3.00	8.50
	2	2.500	3.124	0.25	4.50	0.63	0.63	2.25	3.38	8.88
	3	2.000	2.624	0.13	4.00	0.63	0.50	2.00	3.13	8.63
5.00	1 (std.)	2.000	2.624	0.13	4.00	0.63	0.50	2.00	3.13	9.38
	2	3.500	4.249	0.25	5.75	0.63	0.63	2.25	3.38	9.63
	3	2.500	3.124	0.25	4.50	0.63	0.63	2.25	3.38	9.63
	4	3.000	3.749	0.25	5.25	0.63	0.63	2.25	3.38	9.63
6.00	1 (std.)	2.500	3.124	0.25	4.50	0.63	0.63	2.25	3.50	10.81
	2	4.000	4.749	0.25	6.50	0.75	0.50	2.25	3.50	10.81
	3	3.000	3.749	0.25	5.25	0.63	0.63	2.25	3.50	10.81
	4	3.500	4.249	0.25	5.75	0.63	0.63	2.25	3.50	10.81

NOTE: For additional information - Call your local Parker Fluidpower Motion and Control Distributor.

6. Bulk Weigher Parts Information

Cast Iron Test Weights

Grip Handle and Nesting Slab Weights

NIST Class F							Optional	
Weight	Part #	Width	Length	Height	Slot Width	Slot Depth*	Price	Traceable Certificate
3,000 lb	12872	20-3/4" (527.1 mm)	20-3/4" (527.1 mm)	29 (736.6 mm)	3-1/2" (88.9 mm)	2-3/4" (69.9 mm)	Consult	Consult
2,500 lb	12854	20-3/4" (527.1 mm)	20-3/4" (527.1 mm)	24-3/4" (628.65 mm)	3-31/32" (100.8 mm)	2-3/4" (69.9 mm)	Consult	Consult
2,000 lb	12868	20-3/4" (527.05 mm)	20-3/4" (527.05 mm)	19-1/2" (495.3 mm)	3-1/2" (88.9 mm)	2-3/4" (69.9 mm)	Consult	Consult
1,500 lb	12864	15-1/8" (384.2 mm)	15-1/8" (384.2 mm)	26-7/8" (682.6 mm)	2-1/2" (63.5 mm)	2-1/4" (57.2 mm)	Consult	Consult
1,250 lb	12858	15" (381.0 mm)	15" (381.0 mm)	23-3/4" (603.3 mm)	2-1/2" (63.5 mm)	2-1/4" (57.2 mm)	Consult	Consult
1,000 lb	12850	15" (381.0 mm)	15-1/2" (393.7 mm)	18-11/16" (474.7 mm)	2-3/4" (69.9 mm)	2-29/32" (73.8 mm)	Consult	Consult
500 lb	12844	11-1/2" (292.1 mm)	12" (304.8 mm)	15-3/4" (400.1 mm)	2-1/2" (63.5 mm)	1-29/32" (48.4 mm)	Consult	Consult
250 lb	12892	9-3/4" (247.65 mm)	9-3/4" (247.65 mm)	12" (304.8 mm)	2-1/2" (63.5 mm)	2" (50.8 mm)	Consult	Consult
200 lb	12890	9-3/4" (247.65 mm)	9-3/4" (247.65 mm)	10" (254 mm)	2-1/2" (63.5 mm)	2" (50.8 mm)	Consult	Consult
100 lb	12862	9-1/8" (231.8 mm)	7" (177.8 mm)	7-7/8" (200.0 mm)	4-1/2" (114.3 mm)	1-1/2" (38.1 mm)	Consult	Consult
50 lb	12839	7-29/32" (200.8 mm)	5-1/2" (139.7 mm)	6-9/16" (166.7 mm)	4-1/2" (114.3 mm)	1-21/32" (42.1 mm)	Consult	Consult
30 lb	12878	8-1/4" (209.6 mm)	4-29/32" (124.6 mm)	4-1/2" (114.3 mm)	4-15/32" (113.5 mm)	31/32" (24.6 mm)	Consult	Consult
25 lb	12833	6-1/2" (165.1 mm)	4-1/2" (114.3 mm)	4-15/16" (125.4 mm)	3-5/8" (92.1 mm)	31/32" (24.6 mm)	Consult	Consult
20 lb	12870	5-3/4" (146.1 mm)	4-15/32" (113.5 mm)	5-3/32" (129.4 mm)	3-31/32" (100.8 mm)	1-5/32" (29.4 mm)	Consult	Consult

6. Bulk Weigher Parts Information

ASTM Class 7

Optional

Weight	Part #	Width	Length	Height	Price	Traceable Certificate
10 lb	12828	5" (127.0 mm)	3-1/4" (82.6 mm)	4-1/32" (102.4 mm)	Consult	Consult
5 lb	12823	4" (101.6 mm)	2-9/16" (65.1 mm)	3-7/32" (81.8 mm)	Consult	Consult
2 lb	12874	3" (76.2 mm)	2-1/8" (54.0 mm)	1-3/4" (44.5 mm)	Consult	Consult
1 lb	12876	2-1/2" (63.5 mm)	1-11/16" (42.9 mm)	1-13/32" (35.7 mm)	Consult	Consult

Nesting Slab NIST Class F

Optional

Weight	Part #	Width	Length	Height	Slot Width	Slot Depth*	Price	Traceable Certificate
2,500 lb	12860	42" (1066.8 mm)	30" (762 mm)	8-1/4" (209.5 mm)	2" (50.8 mm)	2-1/4" (57.15 mm)	Consult	Consult
1,000 lb	34563	29-1/2" (749.3 mm)	19-1/2" (495.3 mm)	7-1/4" (184.15 mm)	2" (50.8 mm)	2-1/4" (57.15 mm)	Consult	Consult

* Slot depth refers to distance between lifting bars and castings

Additional Accessories

Part #	Description	Price
36092	Statement of Accuracy	Consult
25836	Serial number	Consult



Figure 6E Nesting Slab (12860)



Figure 6F Grip Handle

6. Bulk Weigher Parts Information

Grip Handle Weights

NIST Class F

Optional

Weight	Part #	Width	Length	Height	Slot Width	Slot Depth*	Price	Traceable Certificate
1,000 kg	12801	20-1/2" (520.7 mm)	20-1/2" (520.7 mm)	22" (558.8 mm)	3-1/2" (88.9 mm)	2-3/4" (69.85 mm)	Consult	Consult
500 kg	12797	15-1/8" (384.2 mm)	15-1/8" (384.2 mm)	20-3/4" (527 mm)	2-1/2" (63.5 mm)	2" (50.8 mm)	Consult	Consult
250 kg	12782	11-1/2" (292.1 mm)	12-1/2" (317.5 mm)	20-1/2" (520.7 mm)	2-1/2" (63.5 mm)	1-7/8" (47.6 mm)	Consult	Consult
200 kg	12793	11-1/2" (292.1 mm)	12" (304.8 mm)	14-1/4" (362 mm)	2-1/2" (63.5 mm)	1-7/8" (47.6 mm)	Consult	Consult
100 kg	12817	9-7/8" (250.8 mm)	9-7/8" (250.8 mm)	11" (279.4 mm)	2-1/2" (63.5 mm)	2" (50.8 mm)	Consult	Consult
50 kg	12803	9-7/32" (234.2 mm)	7" (177.8 mm)	8-13/16" (223.8 mm)	4-15/32" (113.5 mm)	1-29/32" (48.4 mm)	Consult	Consult
35 kg	12805	7-7/8" (200.0 mm)	5-1/2" (139.7 mm)	9-15/32" (252.4 mm)	4-15/32" (113.5 mm)	1-1/16" (27.0 mm)	Consult	Consult
25 kg	12775	7-21/32" (194.5 mm)	5-1/2" (139.7 mm)	7-3/32" (180.2 mm)	4-7/16" (112.7 mm)	1-13/16" (46.0 mm)	Consult	Consult
20 kg	12771	7-5/8" (193.7 mm)	5-19/32" (142.1 mm)	5-29/32" (150.0 mm)	4-5/8" (117.5 mm)	1-19/32" (40.5 mm)	Consult	Consult
10 kg	12767	6" (152.4 mm)	4-1/2" (114.3 mm)	5" (127.0 mm)	3-3/4" (95.3 mm)	1-1/16" (27.0 mm)	Consult	Consult

ASTM Class 7

Optional

Weight	Part #	Width	Length	Height	Price	Traceable Certificate
5 kg	12786	5-15/32" (138.9 mm)	3-13/32" (86.5 mm)	4-1/8" (104.8 mm)	Consult	Consult
2 kg	12809	3-31/32" (100.8 mm)	2-9/16" (65.1 mm)	2-13/16" (71.4 mm)	Consult	Consult
1 kg	12813	3" (76.2 mm)	2-1/8" (54.0 mm)	1-27/32" (46.8 mm)	Consult	Consult
500 g	12815	2-1/2" (63.5 mm)	1-5/8" (41.3 mm)	1-17/32" (38.9 mm)	Consult	Consult

6. Bulk Weigher Parts Information

OIML Class M1

Optional

Weight	Part #	Width	Length	Height	Slot Width	Slot Depth*	Price	Traceable Certificate
500 kg	156304	15-1/8" (384.2 mm)	15-1/8" (384.2 mm)	20-3/4" (527 mm)	2-1/2" (63.5 mm)	2" (50.8 mm)	Consult	Consult
250 kg	156305	15-1/8" (384.2 mm)	15-1/8" (384.2 mm)	20-3/4" (527 mm)	2-1/2" (63.5 mm)	1-7/8" (47.6 mm)	Consult	Consult
100 kg	156306	15-1/8" (384.2 mm)	15-1/8" (384.2 mm)	20-3/4" (527 mm)	2-1/2" (63.5 mm)	2" (50.8 mm)	Consult	Consult
50 kg	105417	9-7/32" (234.2 mm)	7" (177.8 mm)	8-13/16" (223.8 mm)	4-15/32" (113.5 mm)	1-29/32" (48.4 mm)	Consult	Consult
20 kg	105416	7-5/8" (193.7 mm)	5-19/32" (142.1 mm)	5-29/32" (150.0 mm)	4-5/8" (117.5 mm)	1-19/32" (40.5 mm)	Consult	Consult
10 kg	105415	6" (152.4 mm)	4-1/2" (114.3 mm)	5" (127.0 mm)	3-3/4" (95.3 mm)	1-1/16" (27.0 mm)	Consult	Consult
5 kg	105414	5-15/32" (138.9 mm)	3-13/32" (86.5 mm)	4-1/8" (104.8 mm)	-	-	Consult	Consult

* Slot depth refers to distance between lifting bars and castings

Additional Accessories

Part #	Description	Price
36092	Statement of Accuracy	Consult
25836	Serial Number	Consult



Figure 6G Grip Handle

Manual Test Weight Lift Assembly 500#

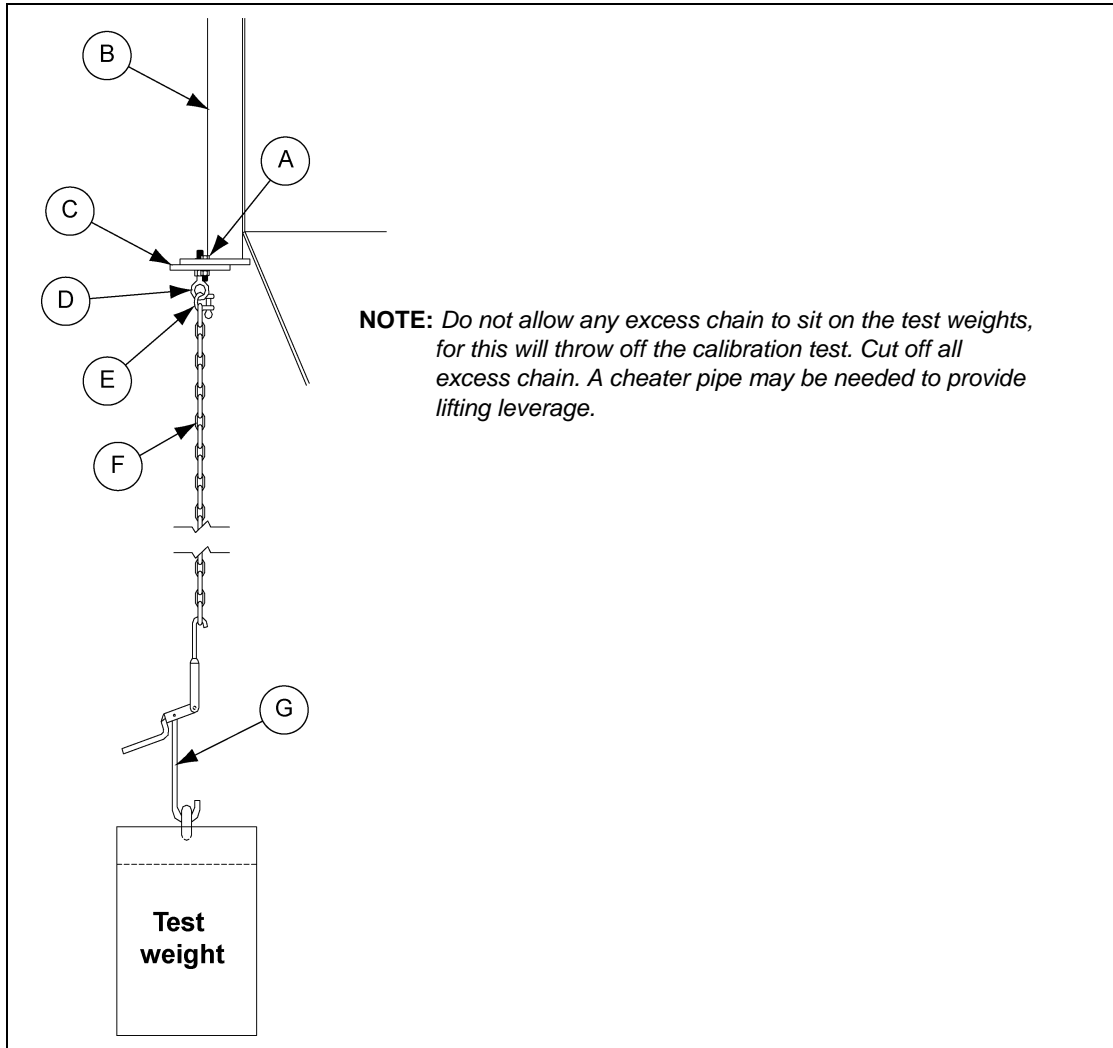

Figure 6H

Ref #	Description
A	Two (2) 1/2" bolts x 2" long required with nuts and lock washers for mounting the test weight adjustment plate.
B	Weigh Hopper Channel
C	Slotted Test Weight Adjustment Plate. Adjust plate so the chain hangs clear of obstacles. (Not required on some scale models.)
D	5/8" x 4" Long Forged Eye Bolt (35899). One nut on each side of adjustment plate. (Not required on some scale models.)
E	3/8" Chain Shackle (35173)
F	1/4" Chain Long (35174). Use only enough chain so it will hang almost tight when the test weight is down.
G	Chain Tightener (36916)

Manual Test Weight Lift Assembly 1000#

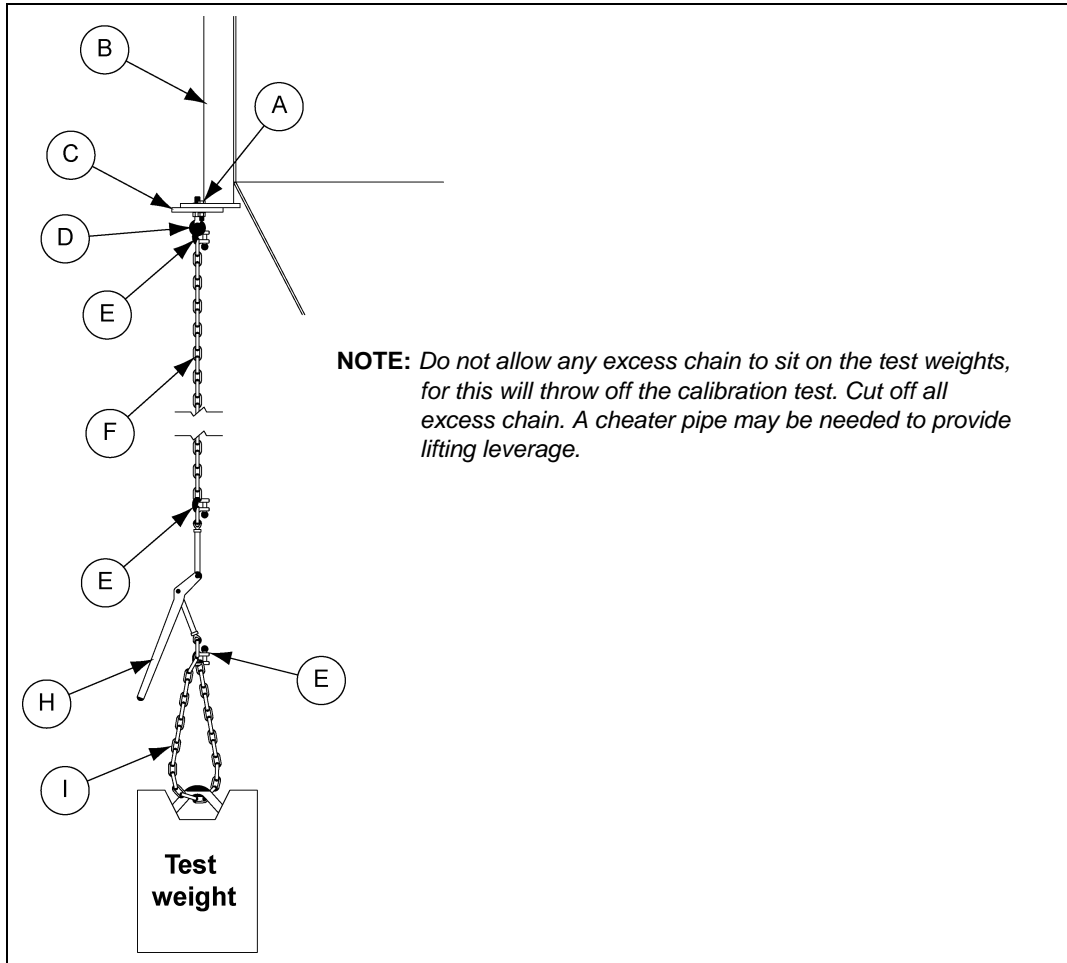

Figure 6I

Ref #	Description
A	Two (2) 1/2" bolts x 2" long required with nuts and lock washers for mounting the test weight adjustment plate.
B	Weigh Hopper Channel
C	Slotted Test Weight Adjustment Plate. Adjust plate so the chain hangs clear of obstacles. (Not required on some scale models.)
D	5/8" x 4" Long Forged Eye Bolt (35899). One nut on each side of adjustment plate. (Not required on some scale models.)
E	3/8" Chain Shackle (35173)
F	1/4" Chain Long (35174). Use only enough chain so it will hang almost tight when the test weight is down.
H	3/8" Load Binder (528401) (Hooks are provided which may be used in place of shackles.)
I	1/4" Chain 2' Long (35174). Use as much as necessary to achieve the desired height of the load binder.

6. Bulk Weigher Parts Information

Manual Test Weight Lift Assembly 2000#

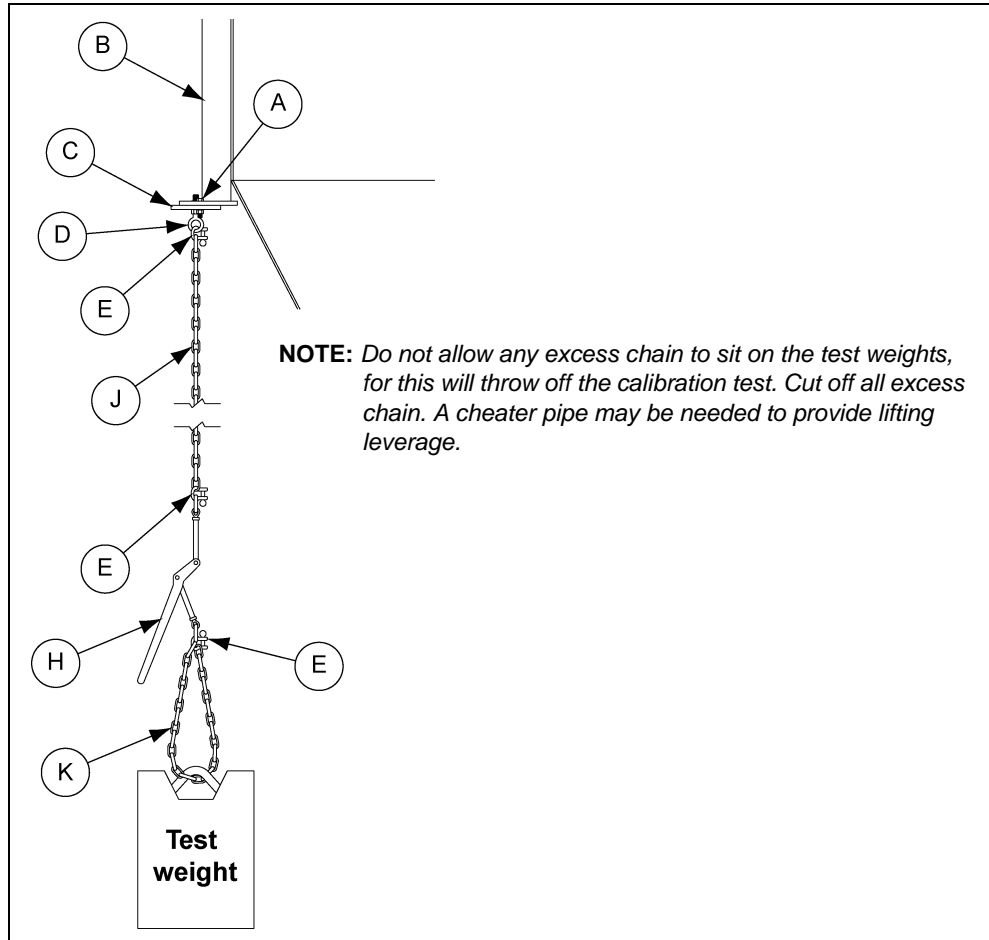

Figure 6J

Ref #	Description
A	Two (2) 1/2" bolts x 2" long required with nuts and lock washers for mounting the test weight adjustment plate.
B	Weigh Hopper Channel
C	Slotted Test Weight Adjustment Plate. Adjust plate so the chain hangs clear of obstacles. (Not required on some scale models.)
D	5/8" x 4" Long Forged Eye Bolt (35899). One nut on each side of adjustment plate. (Not required on some scale models.)
E	3/8" Chain Shackle (35173)
H	3/8" Load Binder (528401) (Hooks are provided which may be used in place of shackles.)
J	3/8" Chain (58400). Use only enough chain so it will hang almost tight when the test weight is down.
K	3/8" Chain 2' Long (528400). Use as much as necessary to achieve the desired height of the load binder.

Hydraulic Test Weight Lift Assembly 1000#

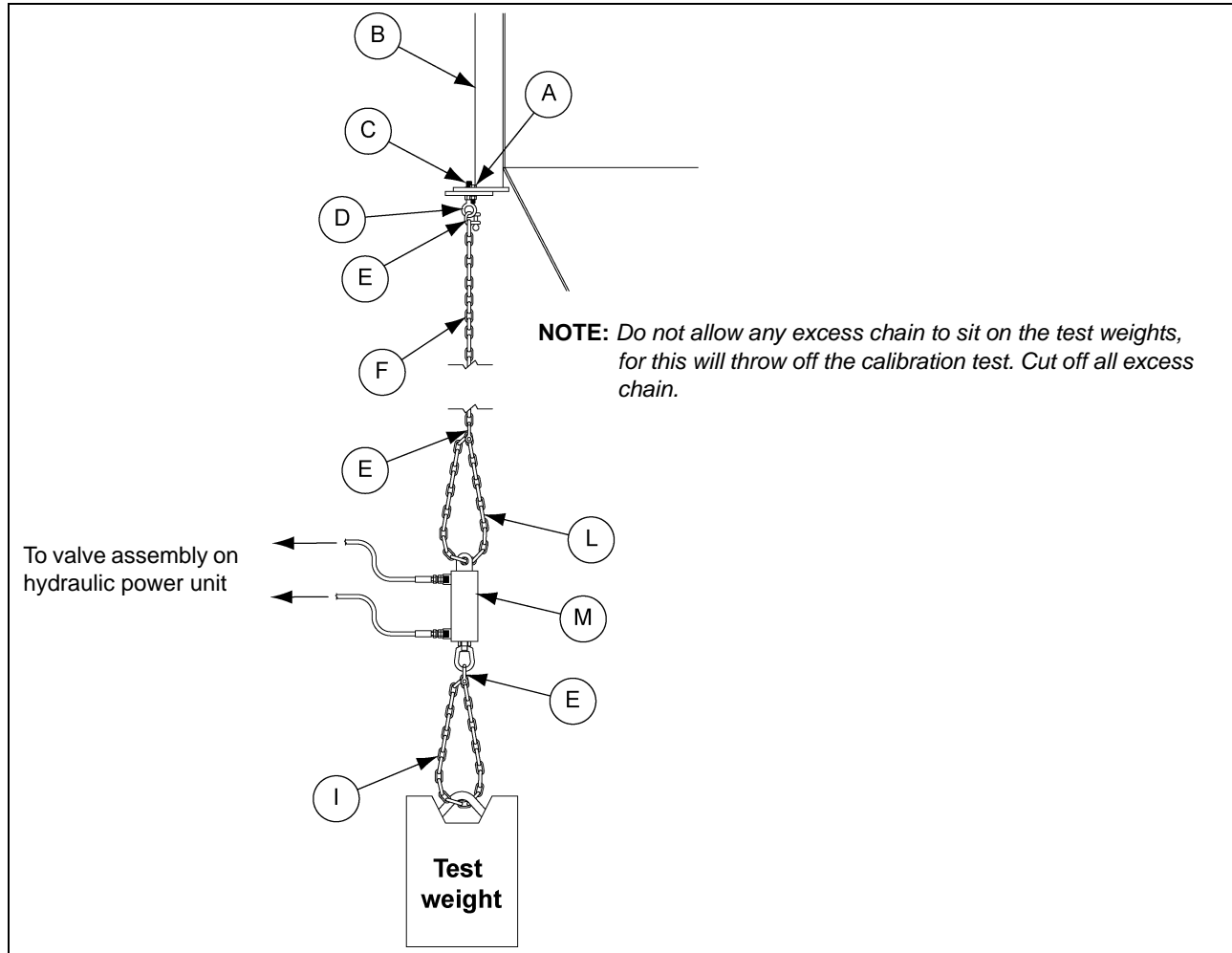

Figure 6K

Ref #	Description
A	Two (2) 1/2" bolts x 2" long required with nuts and lock washers for mounting the test weight adjustment plate.
B	Weigh Hopper Channel
C	Slotted Test Weight Adjustment Plate. Adjust plate so the chain hangs clear of obstacles. (Not required on some scale models.)
D	5/8" x 4" Long forged eye bolt (35899) one nut on each side of adjustment plate. (Not required on some scale models.)
E	3/8" Chain shackle (35173)
F	1/4" Chain Long (35174). Use only enough chain so it will hang almost tight when the test weight is down.
I	1/4" Chain 2' Long (35174). Use as much as necessary to achieve the desired height of the cylinder.
L	1/4" Chain 1' Long (35174)
M	Hydraulic Cylinder Test Weight Lift Assembly (511094)

7. Hydraulic Power Unit Schematic Drawings

Hydraulic Power Unit 5 HP TEFC PSR/COMP (532295)

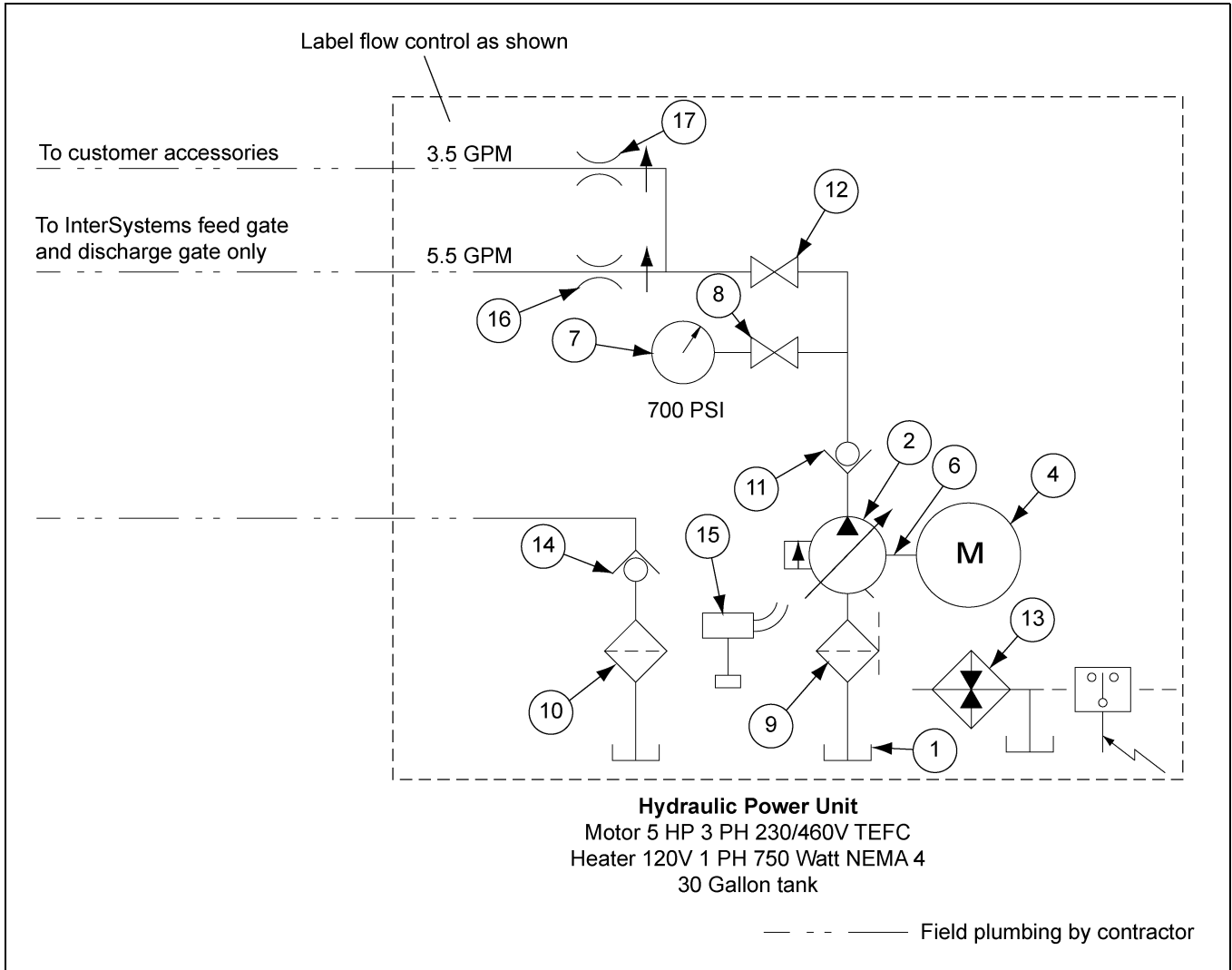

Figure 7A

7. Hydraulic Power Unit Schematic Drawings

Hydraulic Power Unit 5 HP TEFC PSR/COMP (532295) Parts List

Ref #	Part #	Description	Qty
1	10030-REV B	Reservoir, 30 Gallon with Site Glass and Thermostat - Vescor	1
2	PVP2320R	Pump, Variable Volume Piston - Parker	1
3	254199	Pump/Motor Adapter (Not Shown)	1
4	130328	Motor, 5 HP TEFC 230/460V, 3 PH 1750 RPM 184TC Frame	1
5	5131	Base Plate, Motor (Not Shown)	1
6	LO95	Coupling - Lovejoy	1
7	25.900-2000	Gauge, Span Pressure 0-2000 PSI	1
8	MV400-S	Shut Off Valve - Parker	1
9	P20-1-1/4-100RV3	Suction Strainer - Flo-Ezy	1
10	15CN110QM250B1B1-1	Filter, Microglass Element - Parker** (Not Shown)	1
11	DT750MOMF-05	Check Valve (Pressure) - Parker	1
12	VP500CS-8	Ball Valve - Parker	1
13	BCS13J1-W2	Heater, 750 Watt, 110V, 1 PH, Nema 4 - Watlow	1
14	C800S	Check Valve (Return) - Parker	1
15	B40033AFD2B705	Switch, Low Level/High Temp (70° C) - Adv. Tech.	1
16	FR101F6006P	Flow Control Pressure Comp., 5.5 GPM - Parker	1
17	FR101F4006P	Flow Control Pressure Comp., 3.5 GPM - Parker	1
18		Lable NOTE: <i>Do not mix hydraulic oil. (Not Shown)</i>	1

*Pump volume set at 9.5 GPM preset to 700 PSI

**Filter replacement element - parker # 932612Q (IS# 543019)

NOTE: *Power unit to be test run, pressure relief to be set at 700 PSI, pump rotation to be highly visibly marked and one certificate of testing sent with power unit and one certificate of testing sent to InterSystems, inc.*

NOTE: *Substitution to any component listed with part number must be approved by InterSystems, Inc.*

7. Hydraulic Power Unit Schematic Drawings

Hydraulic Power Unit 5 HP IIG PSR/COMP (532304)

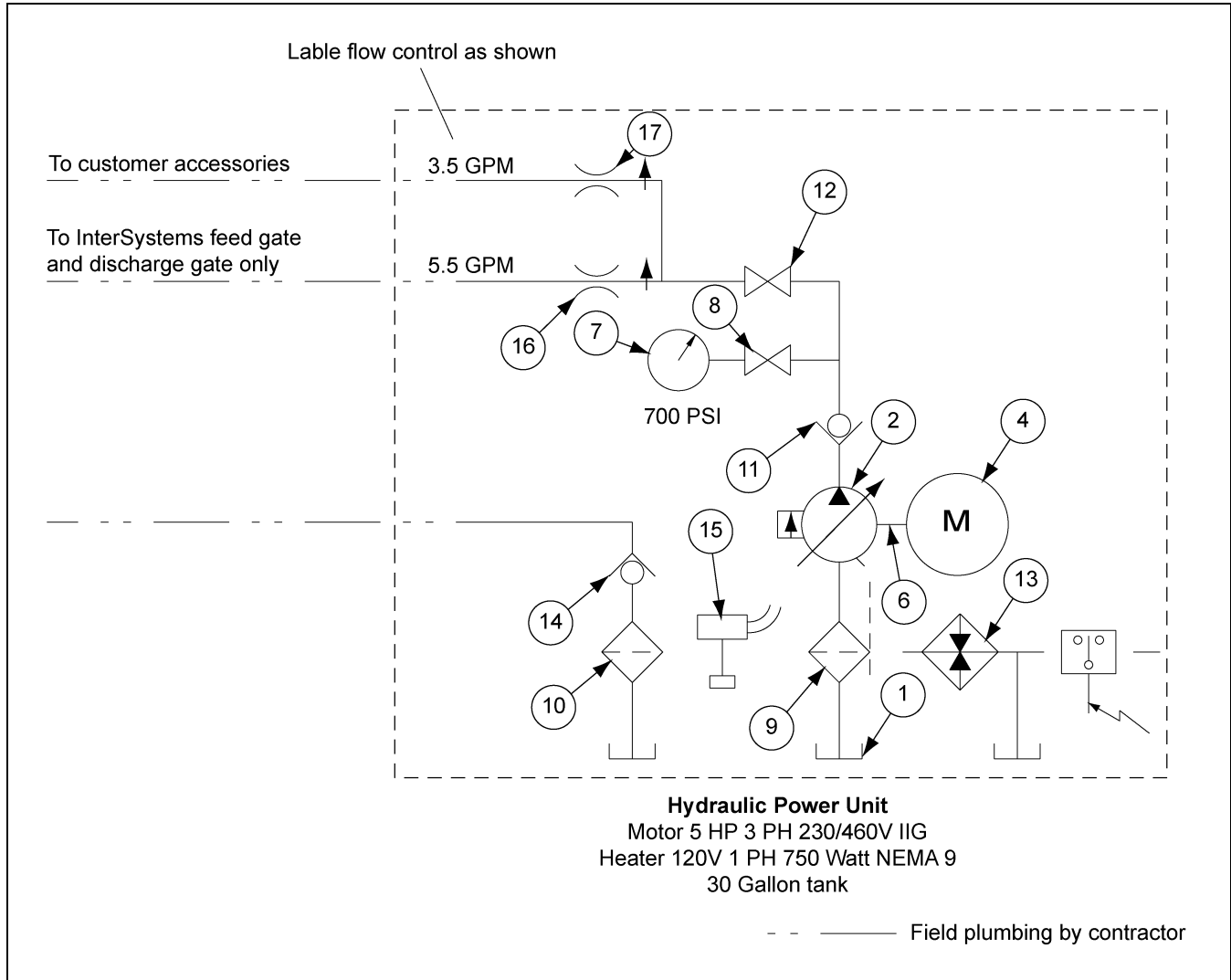

Figure 7B

7. Hydraulic Power Unit Schematic Drawings

Hydraulic Power Unit 5 HP IIG PSR/COMP (532304) Parts List

Ref #	Part #	Description	Qty
1	10030-REV B	Reservoir, 30 Gallon with Site Glass and Thermostat - Vescor	1
2	PVP2320R	Pump, Variable Volume Piston - Parker	1
3	1952	Pump/Motor Adapter (Not Shown)	1
4	C365	Motor, 5 HP IIG 230/460V, 3 PH 1750 RPM 184TC Frame	1
5	5135	Base Plate, Motor (Not Shown)	1
6	LO95	Coupling - Lovejoy	1
7	Q810	Gauge, Span Pressure 0-2000 PSI	1
8	MV400-S	Shut Off Valve - Parker	1
9	P20-1-1/4-100RV3	Suction Strainer - Flo-Ezy	1
10	15CN110QM250B1B1-1	Filter, Microglass Element - Parker**	1
11	DT750MOMF-05	Check Valve (Pressure) - Parker	1
12	VP500CS-8	Ball Valve - Parker	1
13	BCS13J1-E/W2	Heater, 750 Watt, 110V, 1 PH, Nema 7/4 - Watlow	1
14	C800S	Check Valve (Return) - Parker	1
15	B40033AFD2B705	Switch, Low Level/High Temp (70° C) IIG - Flotect	1
16	EDSC171	Enclosure IIG (For Switch)	1
17	DSD957	Cover Enclosure	1
18	FR101F6006P	Flow Control Pressure Comp., 5.5 GPM - Parker	1
19	FR101F4006P	Flow Control Pressure Comp., 3.5 GPM - Parker	1
20		Lable NOTE: Do not mix hydraulic oil. (Not Shown)	1

*Pump volume set at 9.5 GPM preset to 700 PSI

**Filter replacement element - parker # 932612Q (IS# 543019)

NOTE: Power unit to be test run, pressure relief to be set at 700 PSI, pump rotation to be highly visibly marked and one certificate of testing sent with power unit and one certificate of testing sent to InterSystems, inc.

NOTE: Substitution to any component listed with part number must be approved by InterSystems, Inc.

7. Hydraulic Power Unit Schematic Drawings

Hydraulic Power Unit 7.5 HP TEFC PSR/COMP (532303)

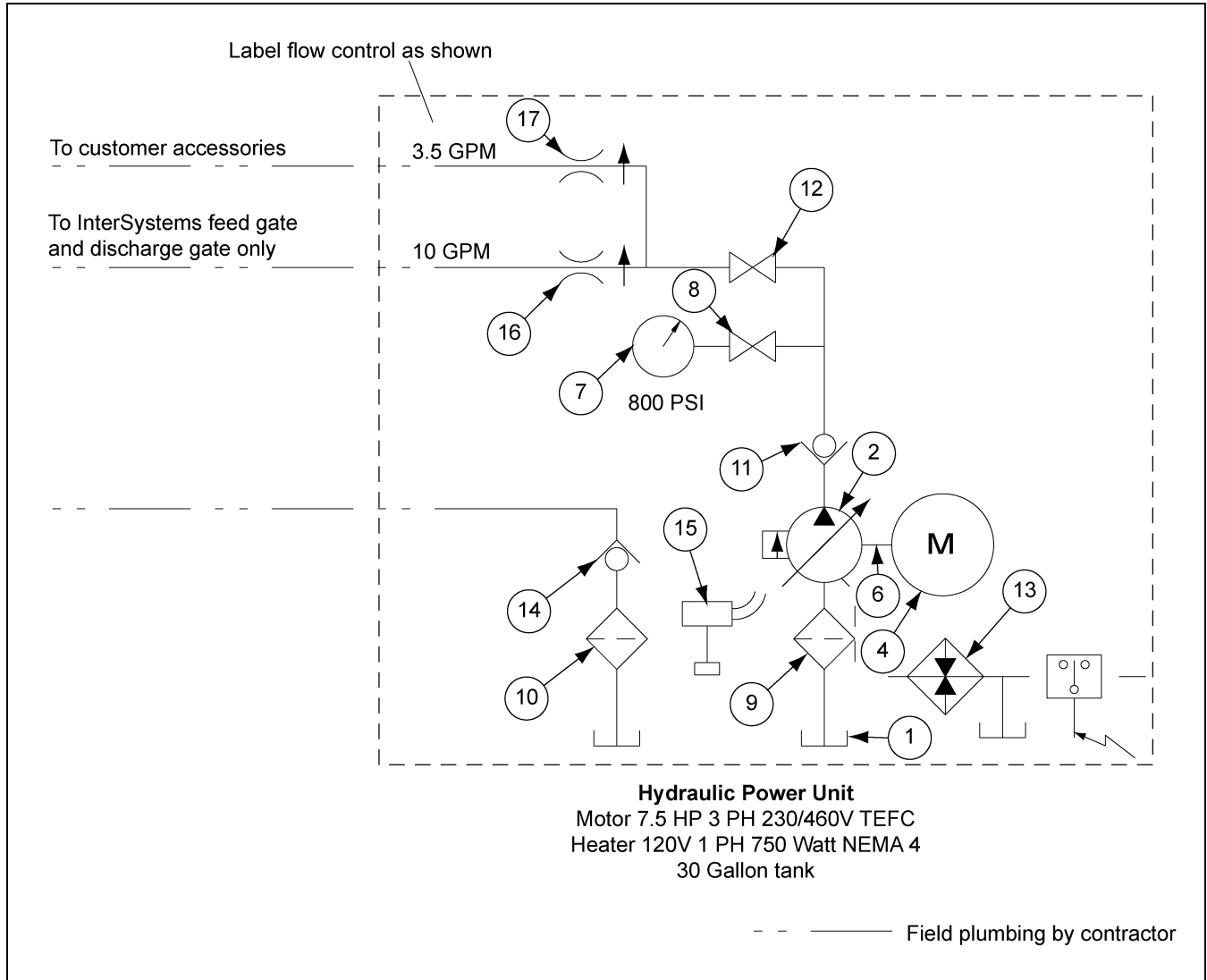

Figure 7C

7. Hydraulic Power Unit Schematic Drawings

Hydraulic Power Unit 7.5 HP TEFC PSR/COMP (532303) Parts List

Ref #	Part #	Description	Qty
1	10030-REV B	Reservoir, 30 Gallon with Site Glass and Thermostat - Vescor	1
2	PVP3320R	Pump, Variable Volume Piston - Parker	1
3	254299	Pump/Motor Adapter (Not Shown)	1
4	PEEEW7.5-18-213TC	Motor, 7.5 HP TEFC 230/460V, 3 PH 1750 RPM 213TC Frame	1
5	5131	Base Plate, Motor (Not Shown)	1
6	L-100	Coupling - Lovejoy	1
7	PFQ810	Gauge, Span Pressure 0-2000 PSI	1
8	MV400-S	Shut Off Valve - Parker	1
9	P20-1-1/4-100RV3	Suction Strainer - Flo-Ezy	1
10	15CN110QEEM2KN124	Filter, Microglass Element - Parker**	1
11	DT750MOMF-05	Check Valve (Pressure) - Parker	1
12	VP500CS-8	Ball Valve - Parker	1
13	BCS13J1-W2	Heater, 750 Watt, 110V, 1 PH, Nema 4 - Watlow	1
14	C800S	Check Valve (Return) - Parker	1
15	B40033AFDB705	Switch, Low Level/High Temp (70° C) - Adv. Tech.	1
16	PCK800S-10.0	Flow Control Pressure Comp., 10 GPM - Parker	1
17	FR101F4006P	Flow Control Pressure Comp., 3.5 GPM - Parker	1
18		Lable NOTE: Do not mix hydraulic oil. (Not Shown)	1

*Pump volume set at 14.0 GPM preset to 800 PSI

**Filter replacement element - parker # 932612Q (IS# 543019)

NOTE: Power unit to be test run, pressure relief to be set at 800 PSI, pump rotation to be highly visibly marked and one certificate of testing sent with power unit and one certificate of testing sent to InterSystems, inc.

NOTE: Substitution to any component listed with part number must be approved by InterSystems, Inc.

7. Hydraulic Power Unit Schematic Drawings

Hydraulic Power Unit 7.5 HP IIG PSR/COMP (532305)

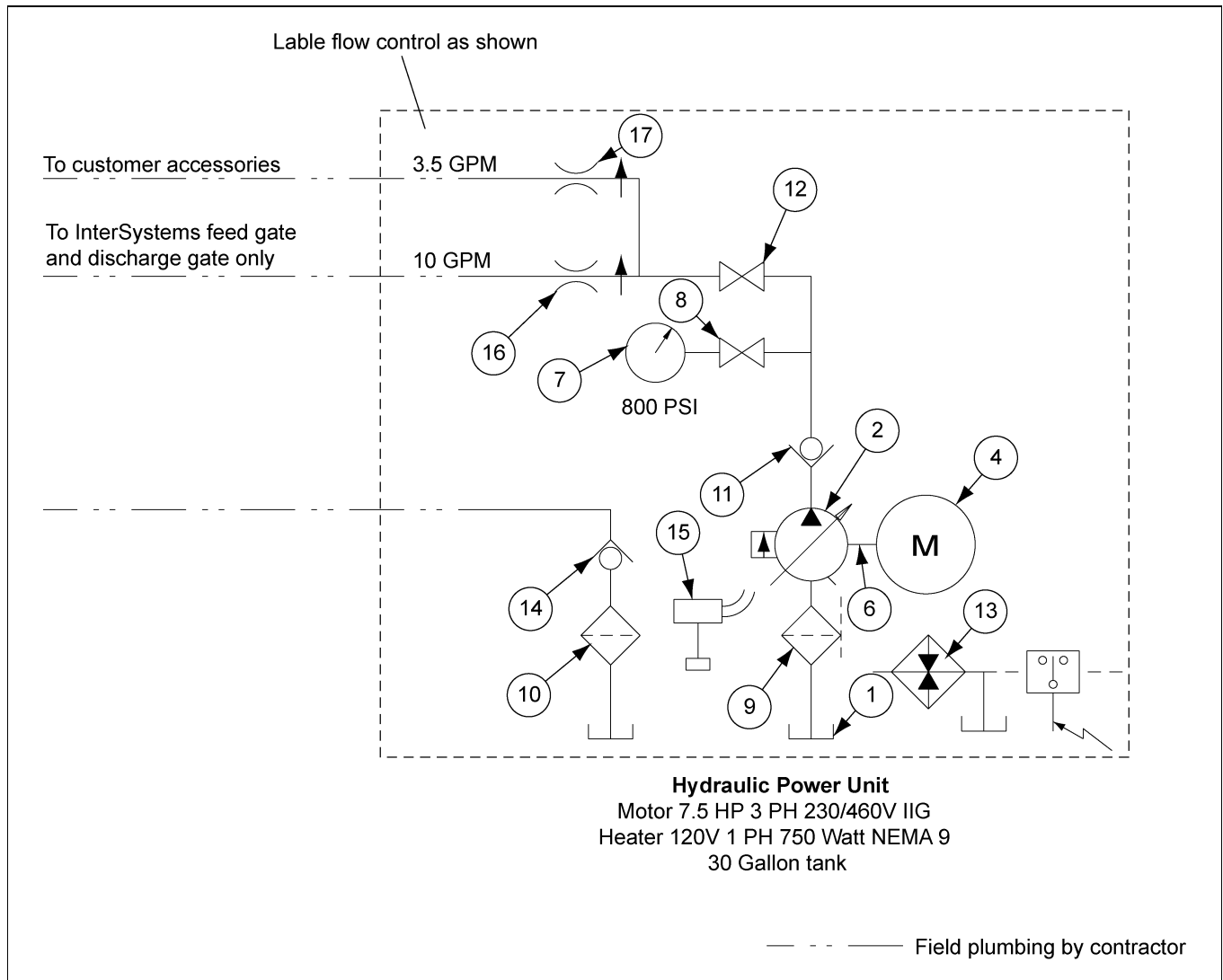

Figure 7D

7. Hydraulic Power Unit Schematic Drawings

Hydraulic Power Unit 7.5 HP IIG PSR/COMP (532305) Parts List

Ref #	Part #	Description	Qty
1	10030-REV B	Reservoir, 30 Gallon with Site Glass and Thermostat - Vescor	1
2	PVP3320R	Pump, Variable Volume Piston - Parker	1
3	254299	Pump/Motor Adapter (Not Shown)	1
4	158157	Motor, 7.5 HP IIG 230/460V, 3 PH 1750 RPM 213TC Frame	1
5	5135	Base Plate, Motor (Not Shown)	1
6	L-110	Coupling - Lovejoy	1
7	25.900-2000	Gauge, Span Pressure 0-2000 PSI	1
8	MV400-S	Shut Off Valve - Parker	1
9	P20-1-1/4-100RV3	Suction Strainer - Flo-Ezy	1
10	15CN110QM250B1B1-1	Filter, Microglass Element - Parker**	1
11	DT750MOMF-05	Check Valve (Pressure) - Parker	1
12	VP500CS-8	Ball Valve - Parker	1
13	BCS13J1-E/W2	Heater, 750 Watt, 110V, 1 PH, Nema 9 - Watlow	1
14	C800S	Check Valve (Return) - Parker	1
15	B40033BFD2B704	Switch, Low Level/High Temp (70° C) - Adv. Tech.	1
16	PPCCK600S10.0	Flow Control Pressure Comp., 10 GPM - Parker	1
17	FR101F4006P	Flow Control Pressure Comp., 3.5 GPM - Parker	1
18	EDSC171	Conduit Box, IIG, Low Level/High Temp Switch	1
19	DSD957	Cover, Conduit Box, IIG, Low Level/High Temp Switch	1
20		Lable NOTE: Do not mix hydraulic oil. (Not Shown)	1

*Pump volume set at 14.0 GPM preset to 800 PSI

**Filter replacement element - parker # 932612Q (IS# 543019)

NOTE: Power unit to be test run, pressure relief to be set at 800 PSI, pump rotation to be highly visibly marked and one certificate of testing sent with power unit and one certificate of testing sent to InterSystems, inc.

NOTE: Substitution to any component listed with part number must be approved by InterSystems, Inc.

7. Hydraulic Power Unit Schematic Drawings

Auto Lift Kit Hydraulic Power Unit (IIG) (532300)

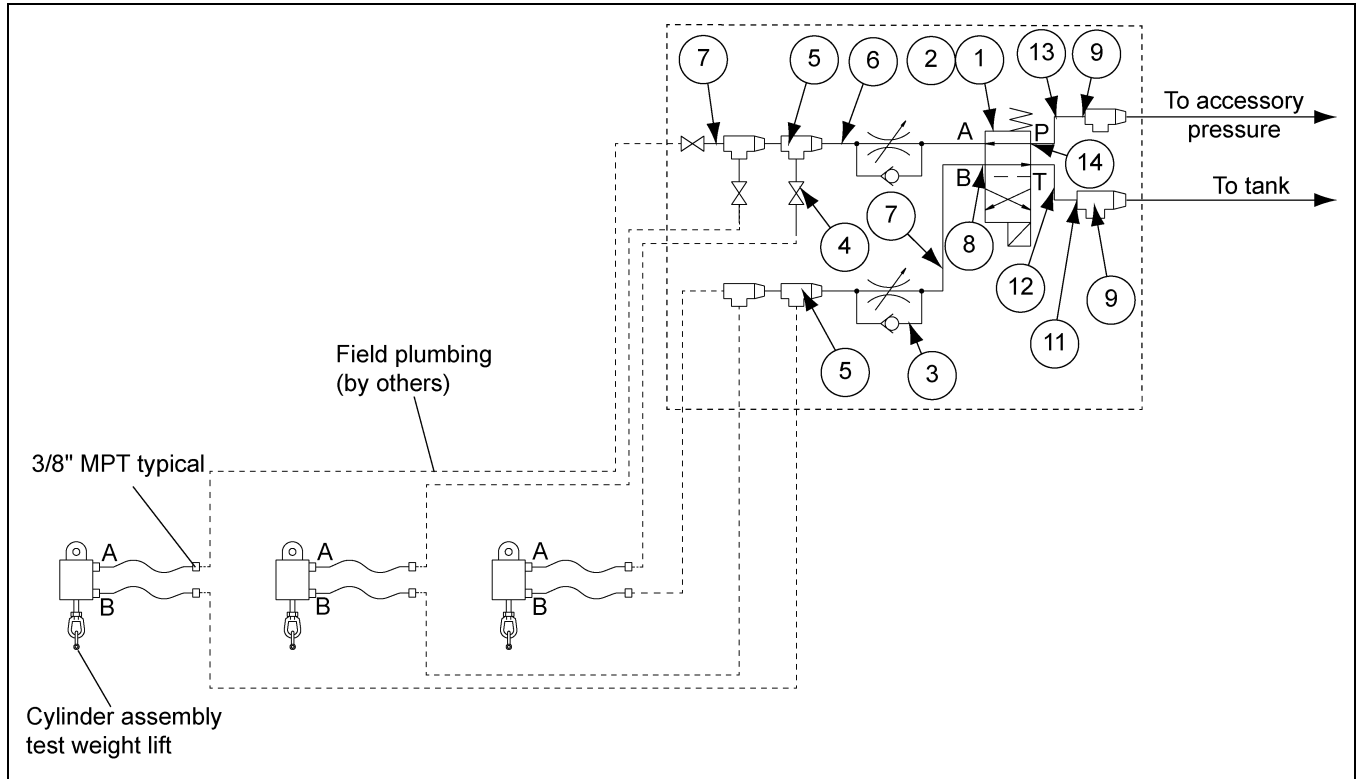

Figure 7E

Auto Lift Kit Hydraulic Power Unit (IIG) (532300) Parts List

Ref #	Part #	Description	Qty
1	* DIVW20BNYCFC	Valve, Hydraulic 2 Position DO3 120V Hazard Location - Parker	1
2	AD03SPS6P	Sub-plate, Side Ports - Daman	1
3	F600-S	Valve, Adjustment Flow Control - Parker	2
4	V500CS-6	Valve, Ball 2000 PSI	3
5	3/8 MRO-S	Tee, Male Run 3/8" - Parker	5
6		Nipple, Black Pipe 3/8" x 3" LG	1
7		Nipple, Black Pipe 3/8" Close	4
8	3/8-CDS	Elbow, 90° 3/8" MPT x 3/8" FPT - Parker	1
9	6-6 VTX-S	Elbow, 45° 3/8" MPT x 3/8" MJIC - Parker	1
10	1/2 MRO-S	Tee, Male Run 1/2" - Parker	1
11	6-8 CTX-S	Elbow, 90° 1/2" MPT x 3/8" Male JIC - Parker	1
12	K4210106-6-6-6-10	Hose, Hydraulic 3/8" MPT x 3/8" FJIC - 10" Long	1
13	K4310606-6-6-6-14	Hose, Hydraulic 3/8" FJIC x 3/8" FJIC - 14" Long	1
14	6-6 CTX-S	Elbow, 90° 3/8" MPT x 3/8" MJIC - Parker	1
15	BK-209	Bolt Kit, DO3 Hydraulic Valve - Parker	1

* Valve not designed for IIG application, but is approved for grain dust application.

Pressure Compensating Piston Pump

Performance Information

Series PVP 23/33 Pressure Compensated, Variable Volume, Piston Pumps

Features

1. High Strength Cast-Iron Housing for Reliability and Quiet Operation
2. Optional Inlet/Outlet Locations for Ease of Installation
3. Replaceable Bronze Port Plate
4. Replaceable Piston Slipper Plate
5. Thru-Shaft Capability SAE AA, A and B Pilots Offered
6. Low Noise Levels
7. Fast Response Times
8. Metric Pilot Shaft and Ports Available

Controls

1. Pressure Compensation
2. Remote Pressure Compensation
3. Load Sensing
4. Torque (Power) Limiting
5. Adjustable Maximum Volume Stop
6. Low Pressure Standby

Schematic Symbol

(Basic Pump)

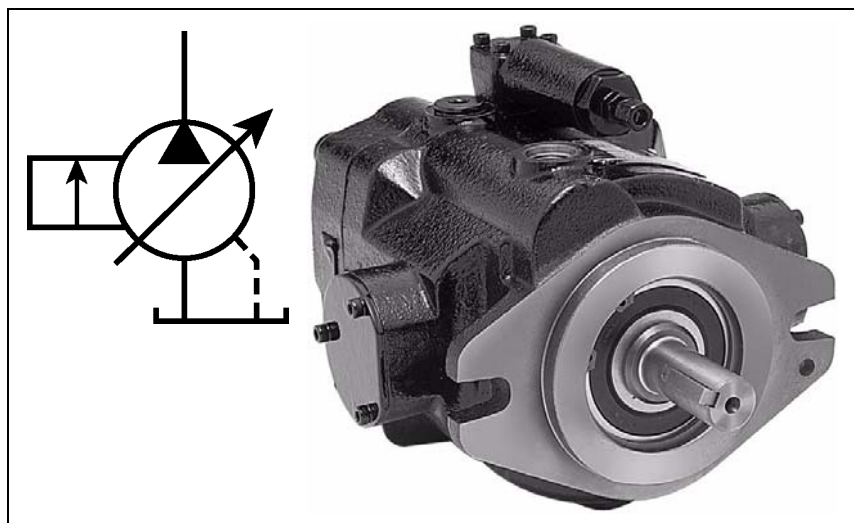

Figure 8A

8. Hydraulic Power Unit Parts Information

Specifications

Pressure Ratings

Outlet Port : 248 bar (3600 PSI) Continuous (P1)

310 bar (4500 PSI) Peak (P3)

Inlet Port : 1.72 bar (25 PSI) Maximum

0.17 bar (5 In. Hg.) Vacuum Minimum @ 1800 RPM

(See inlet chart for other speeds)

Speed Ratings : 600 to 3000 RPM

Operating Temperature Range :

Housing Material : Cast-Iron

Filtration : Maintain SAE Class 4, ISO 16/13, ISO 18/15 Maximum

Mounting : SAE "B" or Metric 2-Bolt Flange Mount

Installation Data : Refer to specific recommendations pertaining to system cleanliness, fluids, start-up, inlet conditions, shaft alignment, drain line restrictions and other important factors relative to the proper installation and use of these pumps.

Quick Reference Data Chart

Pump Model	Displacement cc/rev (In ³ /rev)	Pump Delivery @ 21 Bar (300 PSI) in LPM (GPM)		Input Power A 1800 RPM, Maximum Displacement and 248 bar (3600 PSI)
		1200 RPM	1800 RPM	
PVP23	23.0 (1.4)	28.0 (7.4)	42.0 (11.1)	19.7 kw (26.5 HP)
PVP33	33.0 (2.0)	39.4 (10.4)	59.0 (15.6)	27.2 kw (36.5 HP)

Installation and Specification Data Model 80CN

Specifications:

Maximum Allowable Operating Pressure (MAOP): 800 PSI (55 bar)

Design Safety Factor: 2.5:1

Rated Fatigue Pressure: 550 PSI (38 bar) Per NFPA/T3.10.5.1-category 2/90



Maximum absolute system pressure must not exceed filters rated fatigue pressure (RFP) of 550 PSI if the system frequently cycles between 0 and RFP. Also, limitations on fittings may restrict operating pressure to less than rated static pressure (RSP) of 800 PSI. Refer to SAE J1065, Table 2 for fitting recommendations. Please consult Parker Filter Division if you have questions about your application.

Operating Temperatures:

Buna N (Nitrile): -40°F to 225°F (-40°C to 107°C)

Viton: -15°F to 275°F (-26°C to 135°C)

Element Collapse Rating:

10C-150 PSI (10 bar)

03B, 10B, 208 - 150 PSI (10 bar)

Visual Indicator (optional): Differential pressure type.

Electrical Indicator (optional): Electrical Switch rated 5A at 125/250 VAC, 7A resistive and 3A inductive at 28 VDC. Color coding: White (N.C.), Red (N.O.), Black (common).

Filter Housing: Aluminum.

Weights (approximate):

80CN-1 12.4 lb. (5.62 kg)

80CN-2 15.2 lb. (6.89 kg)

8. Hydraulic Power Unit Parts Information

Tolerances (all models)

To one decimal place - 23mm

- 009

To two decimal places - 15mm

- 006

To Three decimal places - 04mm

- 0015

Linear measure millimeter inch

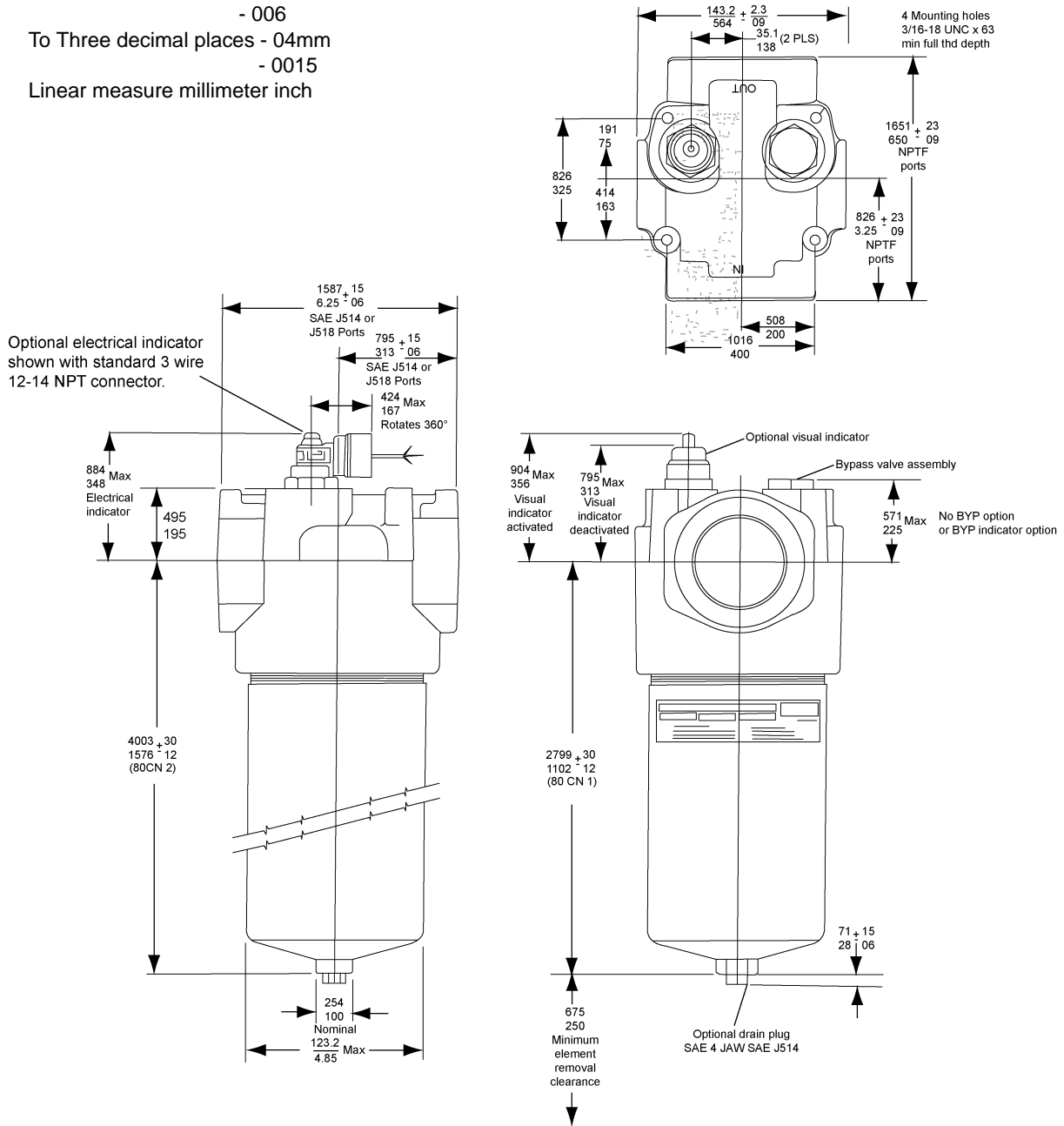

Figure 8B

How to Order:

Select the desired symbol (in the correct position) to construct a model code.

Example:

BOX 1	BOX 2	BOX 3	BOX 4	BOX 5	BOX 6	BOX 7	BOX 8	BOX 9
	15 CN	1	10Q	M2	25	B1B1	1	(Assigned by Parker)

BOX 1: Seals

Symbol	Description
None	Buna N (Nitrile)
E8	EPR
F3	Viton

BOX 2: Model

Symbol	Description
15CN	In-Line Filter
40CN	In-Line Filter
80CN	In-Line Filter

BOX 3: Housing Length

Symbol	Description
1	Single
2	Double

BOX 4: Media Core

Symbol	Description
10C	Cellulose
20Q	Microglass II
10Q	Microglass II
05Q	Microglass II
02Q	Microglass II
WR	Water removal

BOX 5: Indicator Options

Symbol	Description
M2	Visual auto reset
E	Electrical (with 1/2" NPT conduit connection and wire leads)
E1	Electrical (with 12" leads only)
E2	Electrical (DIN 43650 Hirschman style connection)
E3	Electrical (ANSI/B93.55M 3-pin Brad Harrison Style Connection)
P	No indicator (use when filter model is equipped with a bypass valve)
N	No indicator (use with no bypass option)

BOX 6: Bypass and Indicator Setting

Symbol	Pressure Setting
25	25 PSI (1.7 bar) Setting
50	50 PSI (3.4 bar) setting if "no bypass" option (-11) and an indicator is selected, above symbols (25,50) denote indicator setting

BOX 7: Ports

Model	Symbol	Description
15CN	B1B1	3/4" NPT
15CN	C1C1	1" NPT
15CN	M4M4	SAE-12 Straight thread
15CN	N4N4	SAE-16 Straight thread
40CN	C1C1	1" NPT
40CN	E1E1	1-1/2" NPT
40CN	N4N4	SAE-16 Straight thread
40CN	P4P4	SAE-24 Straight thread
80CN	E1E1	1-1/2" NPT
80CN	F1F1	2" NPT
80CN	P4P4	SAE-24 Straight thread
80CN	R4R4	SAE-32 Straight thread
80CN	Y9Y9	Flange face, SAE 2"

BOX 8: Options

Symbol	Description
1	None
11	No bypass
19	Drain port on bowl
21	No bypass and drain port

BOX 9: Design Number

Applied to filter assembly by Parker Filter Division. Use the full filter model code, including the design number when ordering replacement parts, elements and cartridges.

8. Hydraulic Power Unit Parts Information

Replacement Element Part Numbers (Viton)

Media	15CN-1	15CN-2	40CN-1	40CN-2	80CN-1	80CN-2
20Q	930369Q	930370Q	930100Q	930119Q	929903Q	929927Q
10Q	932612Q	932618Q	932651Q	932655Q	932661Q	932667Q
05Q	932611Q	932617Q	932650Q	932654Q	932660Q	932666Q
02Q	932610Q	932616Q	932649Q	932653Q	932659Q	932665Q
10C	925385	925394	930096	930115	929912	929936
WR	N/A	N/A	931412	931414	931416	931418

Suction Strainer

Sump Strainers – Nylon Connector

How to Order

Select the desired specifications from the ordering table and build an ordering code number, as shown in this sample:

P	-	50	-	2	-	Nipple	-	100	-	RV-3
Style	-	GPM	-	NPT	-	Connection (Spell out NIP- PLE if wanted)	-	MESH	-	Valve (Omit if not wanted)

Style	GPM (Flow Capacity)	NPT (Pipe size)	Connection (Not or Nipple)	Mesh (Screen size)	Valve (Optional)
P (std. Nyl-End)	2	1/8, 1/4, 3/8, 1/2	Nut Only	30	RV-3 (3-psi bypass)
	3	1/4	Nut or Nipple (to get nipple you must specify it)		
PASS (S.S. Nyl-End)	3	3/8, 1/2, 3/4	Nut or Nipple (to get nipple you must specify it)	60	RV-5 5-psi bypass)
	5	3/4, 1, 1-1/4	Nut no symbol		
	10	3/4, 1, 1-1/4	Nut no symbol		
	20	3/4, 1, 1-1/4	Nut no symbol	100	
	30	1-1/2 and 2	Nipple Style (see chart on Page 75.)		
	50	1-1/2 and 2	Nipple Style (see chart on Page 75.)		
	50	2-1/2	Nipple Only	200	
	75	2-1/2	Nut or Nipple (to get nipple you must specify it)		
	100	3	Nut or Nipple (to get nipple you must specify it)		
	150	3	Nut or Nipple (to get nipple you must specify it)		

(Pressure drop through a clean element will not exceed 0.2 psi (0.4-in. Hg) at rated flow of 150 SSU viscosity fluid.)

Nylon Connector Type

“Nyl-End” sump strainers (Style P) are made with the same selection of stainless steel elements as the standard all-metal units. They differ in that the connector end pieces are molded in a single piece of glass-reinforced nylon resin. Pleated stainless elements are epoxy-bonded in place.

They are as serviceable as all-metal units, but they cost 12 to 50 percent less, depending on size.

All-Stainless Construction

All-stainless-steel sump strainers with nylon connectors (Style PASS) are available in the same wide variety of sizes and element mesh sizes as the standard Nyl-End units. For excellent resistance to oxidation and corrosion. (Not always a stocked item.)

Nut Style

GPM Rating	Screen Area (Sq. Inches)	NPT (Pipe Size)	Overall Dimensions	
			Diameter	Length
2	30	1/8, 1/4, 3/8, 1/2	1-5/8	4-3/16
3	35	1/4, 3/8, 1/2, 3/4	2-1/4	2-11/16
5	50	3/4, 1, 1-1/4	3-3/16	3-1/2
10	110	3/4, 1, 1-1/4	3-3/16	5-3/4
20	145	3/4, 1, 1-1/4	3-3/16	7-3/8
30	260	1-1/2, 2	4-3/16	9-3/4
50	280	1-1/2, 2	4-3/16	9-3/4
75	350	2-1/2, 3	5-3/16	12-1/2
100	450	2-1/2, 3	5-3/16	12-1/2
150	675	3	5-3/16	17-3/4

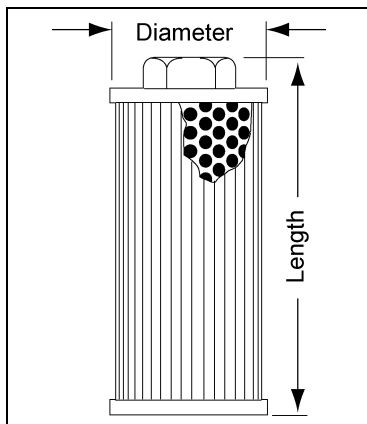

Figure 8C Nut Style

Nipple Style

GPM Rating	Screen Area (Sq. Inches)	NPT (Pipe Size)	Overall Dimensions	
			Diameter	Length
3	35	3/8, 1/2, 3/4	2-1/4	3-3/4
5	50	1	3	3-13/16
10	110	1	3	6-1/16
20	145	1	3	7-11/16
30	260	1-1/2	4-3/16	11-3/8
30	260	2	4-3/16	11-3/8
50	280	1-1/2	4-3/16	11-3/8
50	280	2	4-3/16	11-3/8
50*	280	2-1/2	4-3/16	9-15/16
75	350	2-1/2, 3	5-3/16	13-3/4
100	450	2-1/2, 3	5-3/16	13-3/4
150	675	3	5-3/16	19

* No hex between nipple and strainer on this part.

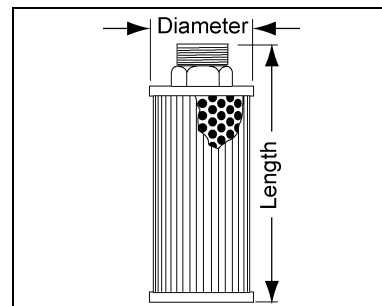

Figure 8D Nipple Style

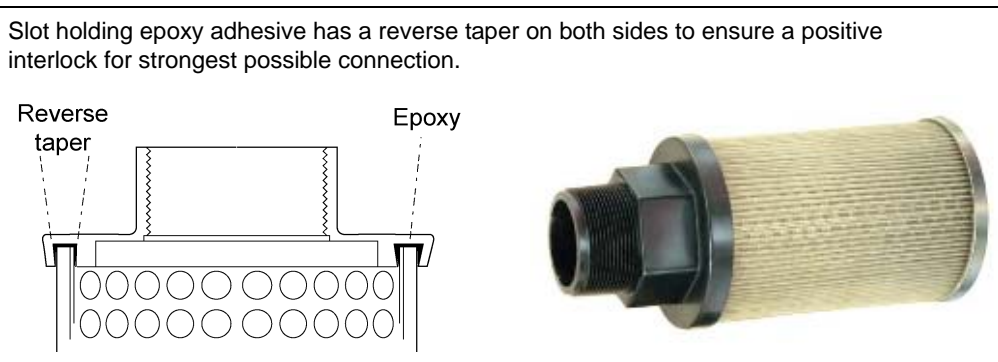

Figure 8E

8. Hydraulic Power Unit Parts Information

Fluid Level and Temperature Switches

ACT4000 Series 120 VA Switch

Description:

Heavy Duty, Combination Level and Temperature Switch monitors both liquid level and temperature. It can be wired to operate electric components such as valves, motor start/stop switches, alarms, warning lights and programmable logic circuits.

Features:

- Invert float to change Level switch function N.O. to N.C. or vice versa in the field .
- 24" long, 18 gauge, 600 volt wires
- Heavy duty float, solid Nylon, compatible with hydraulic oil, phosphate esters and additives.
- Hex I.D. float eliminates sticking like round I.D. floats.
- Metal stem, 1/4" NPT threads, large 9/16" wrench flats
- Electrical load ratings,
 - Level switch 120 VA, SPST
 - AC Maximums, Switching voltage 250
 - Switching current 3.0 amps.
 - Temperature switch 6.0 Amps at 120 VAC on N.O. and N.C.
 - 1.0 Amps at 120 VAC on SPDT
- Self heating of temperature switch when closed changes switch opening point up to 10°C.
- All electrical specifications at 68°F and resistive load.
- Derate electrical limits with increase in temperature and inductive loads (relays, motors and solenoid valves).
- Surge or voltage spike protection required for inductive load or premature switch failure will occur.

Ordering Information:

1/4" NPT Male, Part Numbers:

B40033BFD2M7**, Normally open, 6 amp. temp. switch
B40033BFD2M8**, Normally closed, 6 amp. temp. switch
B40033BFB2M6**, SPDT, 1 amp. temp. switch

1/4" NPT Female, Part Numbers:

B40043BFD2M7**, Normally open, 6 amp. temp. switch
B40043BFD2M8**, Normally closed, 6 amp. temp. switch
B40043BFB2M6**, SPDT, 1 amp. temp. switch

** Specify temperature switch trip point in degrees centigrade, note 60°C = 140°F.

NOTE: *Specify temperature set point in 5°C increments (5°C-100°C).*

Normally **OPEN** temperature switch will close on rising temperature at **, specified trip point.

Normally **CLOSED** temperature switch will open on rising temperature at **, specified trip point.

8. Hydraulic Power Unit Parts Information

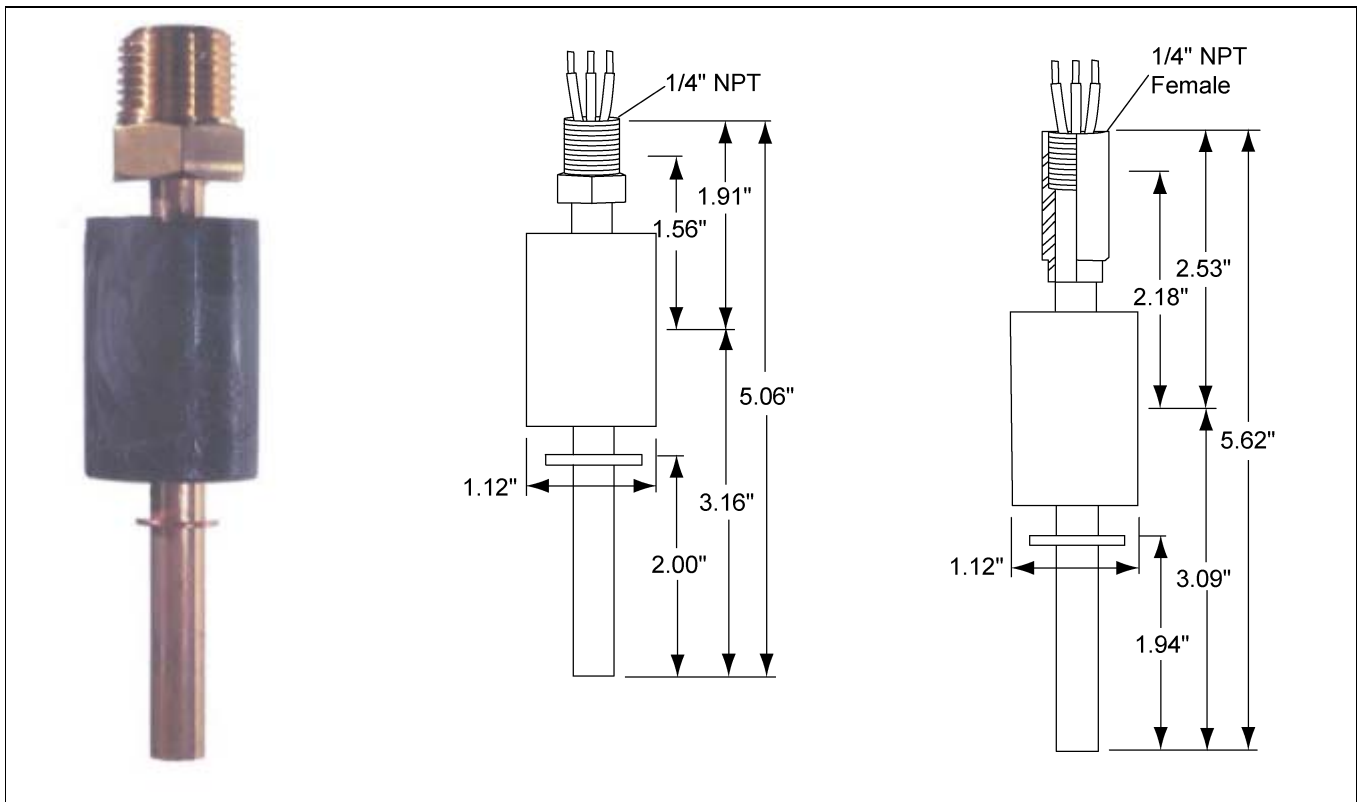

Figure 8F

Low level/high temp switch wiring schematic level switch normally closed operation temperature switch normally open to close at set point.

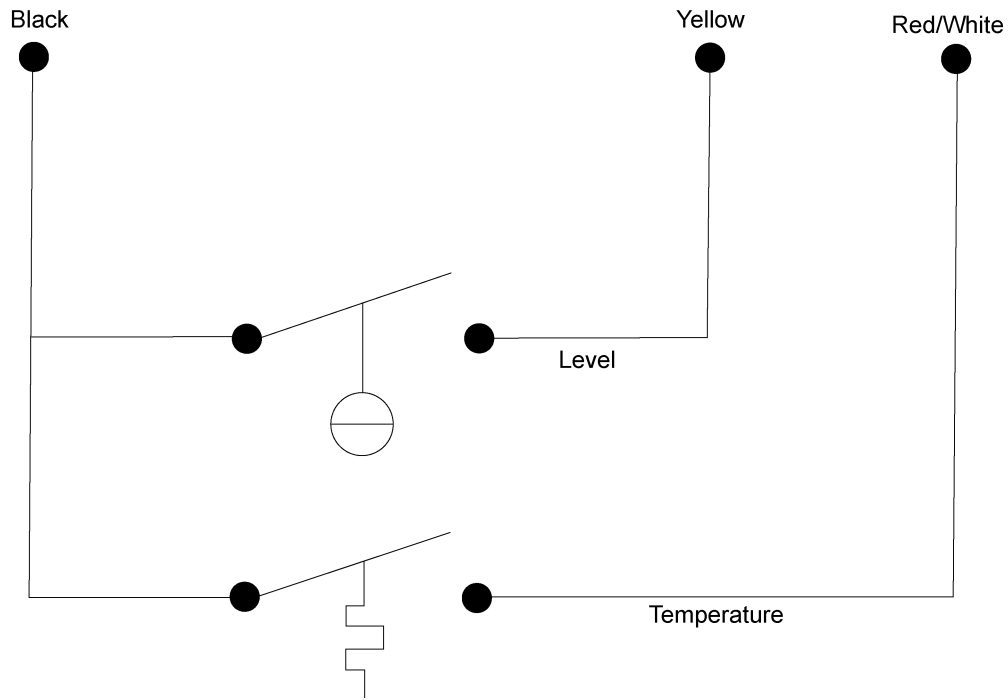
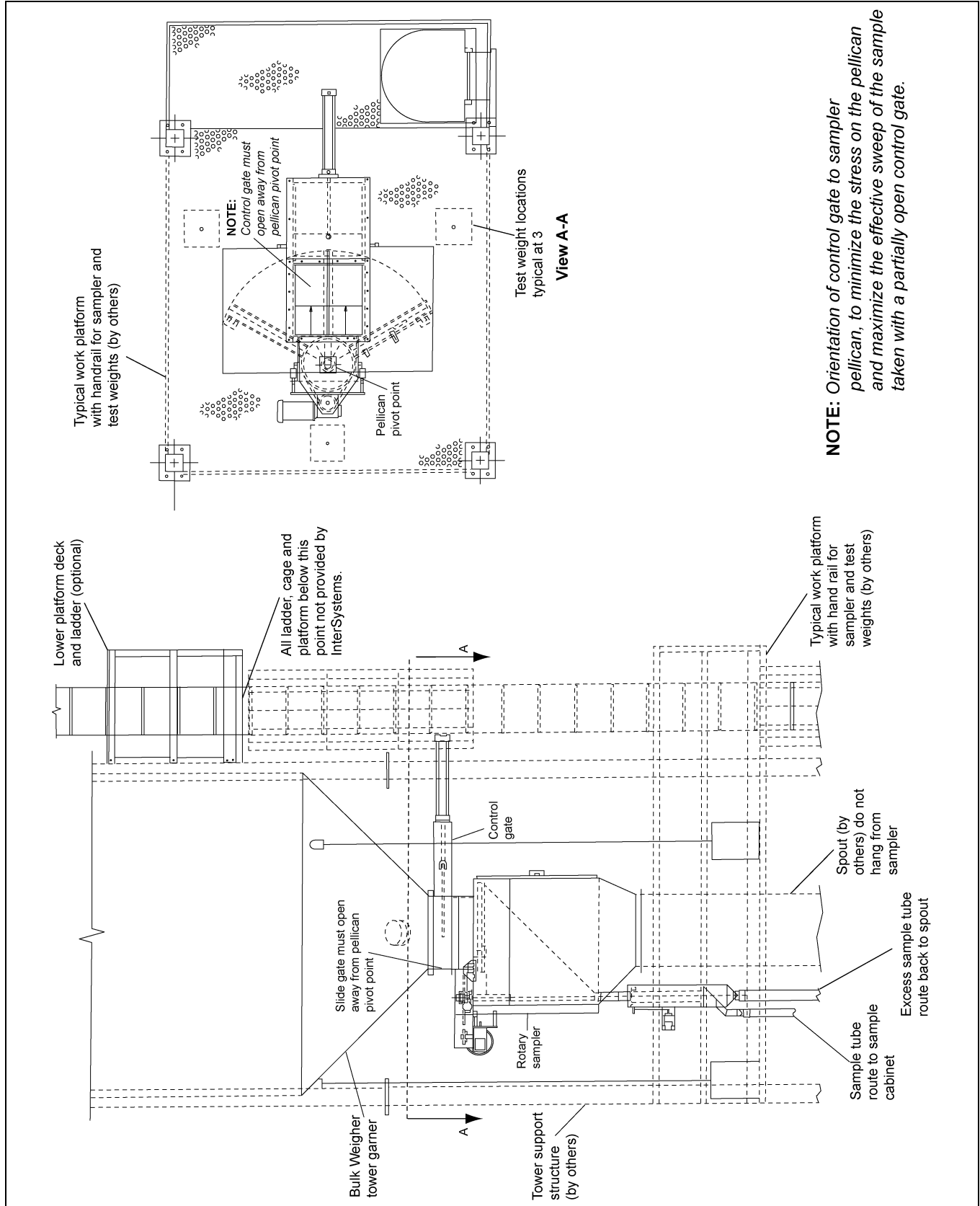

Figure 8G

Sampler Control Gate Orientation



NOTE: Orientation of control gate to sampler pellican, to minimize the stress on the pellican and maximize the effective sweep of the sample taken with a partially open control gate.

Figure 9A

Hydraulic System Schematics

Please note that the following drawings are use on standard configurations as listed below. For Custom Bulk Weigher, refer to the certified drawings sent with the system. On a factory assembled Bulk Weigher a set of drawings can be found in the electrical termination box.

- If your system has : 5 HP Motor on Hydraulic Power Unit
Pressure Compensating Pump on Hydraulic Power Unit MasterWeigh,
Century, or OneWeigh Controller
(*Single solenoid on feed gate*)
- Refer to : 532396 HYD SCHEM 5HP PRSR COMP. 1W
- If your system has : 5 HP Motor on Hydraulic Power Unit
Pressure Compensating Pump on Hydraulic Power Unit CompuWeigh
Controller (CD2000 or CD3000)
(*Dual solenoid on feed gate*)
- Refer to : 534257 HYD SCHEM 5HP PRSR COMP. TRIM
- If your system has : 7.5 HP Motor on Hydraulic Power Unit
Pressure Compensating Pump on Hydraulic Power Unit MasterWeigh,
Century, or OneWeigh Controller
(*Single solenoid on feed gate*)
- Refer to : 532377 HYD SCHEM 7.5HP PRSR COMP. 1W
- If your system has : 7.5 HP Motor on Hydraulic Power Unit
Pressure Compensating Pump on Hydraulic Power Unit CompuWeigh
Controller (CD2000 or CD3000)
(*Dual solenoid on feed gate*)
- Refer to : 532392 HYD SCHEM 7.5HP PRSR COMP. TRIM

Hydraulic Schematic 5 HP Pressure Component 1W (532396)

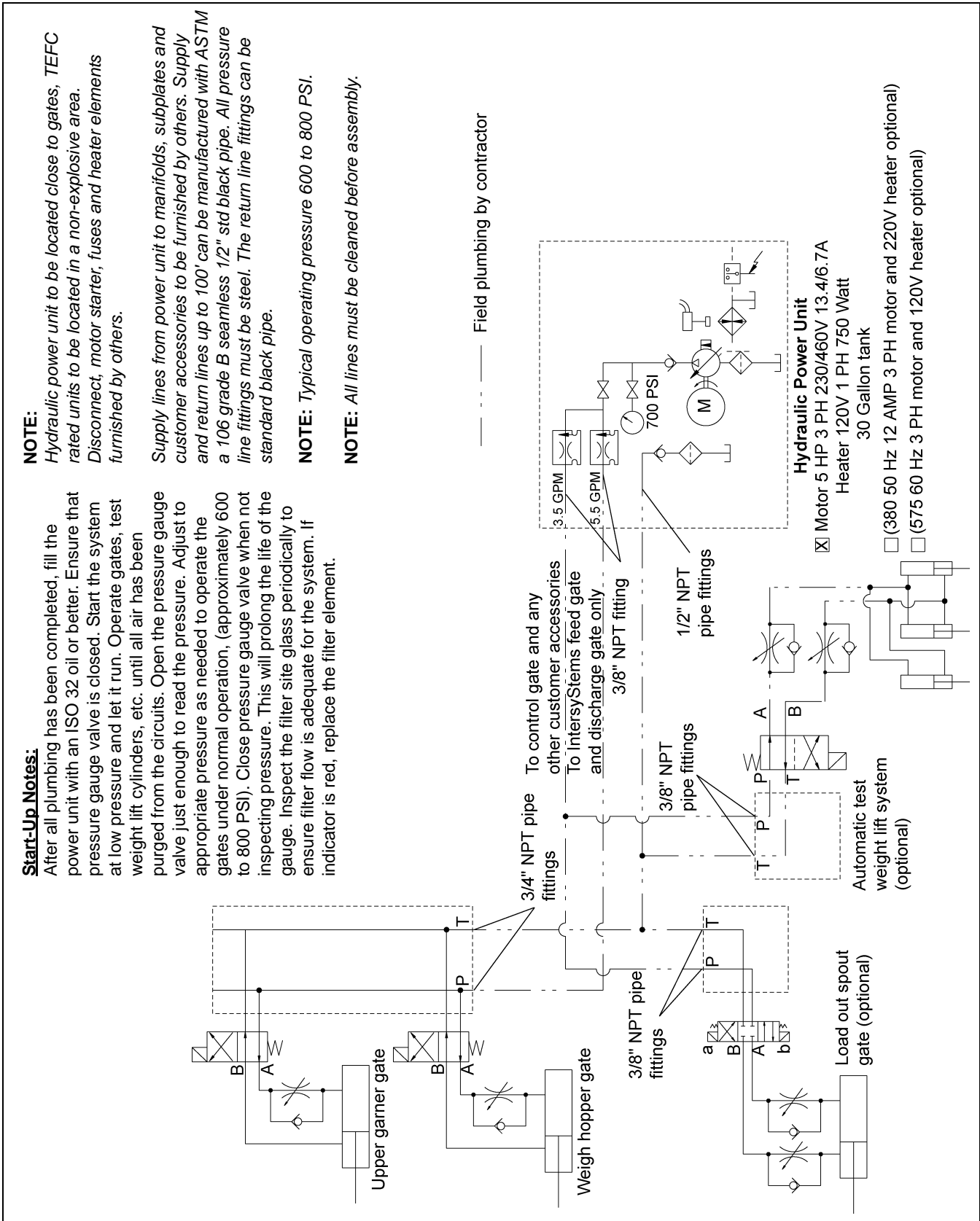

Figure 10A

Hydraulic Schematic 5 HP Pressure Compound Trim (534257)

Start-Up Notes:

After all plumbing has been completed, fill the power unit with an ISO 32 oil or better. Ensure that pressure gauge valve is closed. Start the system at low pressure and let it run. Operate gates, test weight lift cylinders, etc. until all air has been purged from the circuits. Open the pressure gauge valve just enough to read the pressure. Adjust to appropriate pressure as needed to operate the gates under normal operation, (approximately 600 to 800 PSI). Close pressure gauge valve when not inspecting pressure. This will prolong the life of the gauge. Inspect the filter site glass periodically to ensure filter flow is adequate for the system. If indicator is red, replace the filter element.

NOTE:

Hydraulic power unit to be located close to gates, TEFC rated units to be located in a non-explosive area. Disconnect, motor starter, fuses and heater elements furnished by others.

Supply lines from power unit to manifolds, subplates and customer accessories to be furnished by others. Supply and return lines up to 100' can be manufactured with ASTM a 106 grade B seamless 1/2" standard black pipe. All pressure line fittings must be steel. The return line fittings can be standard black pipe.

NOTE: Typical operating pressure 600 to 800 PSI.

NOTE: All lines must be cleaned before assembly.

----- Field plumbing by contractor

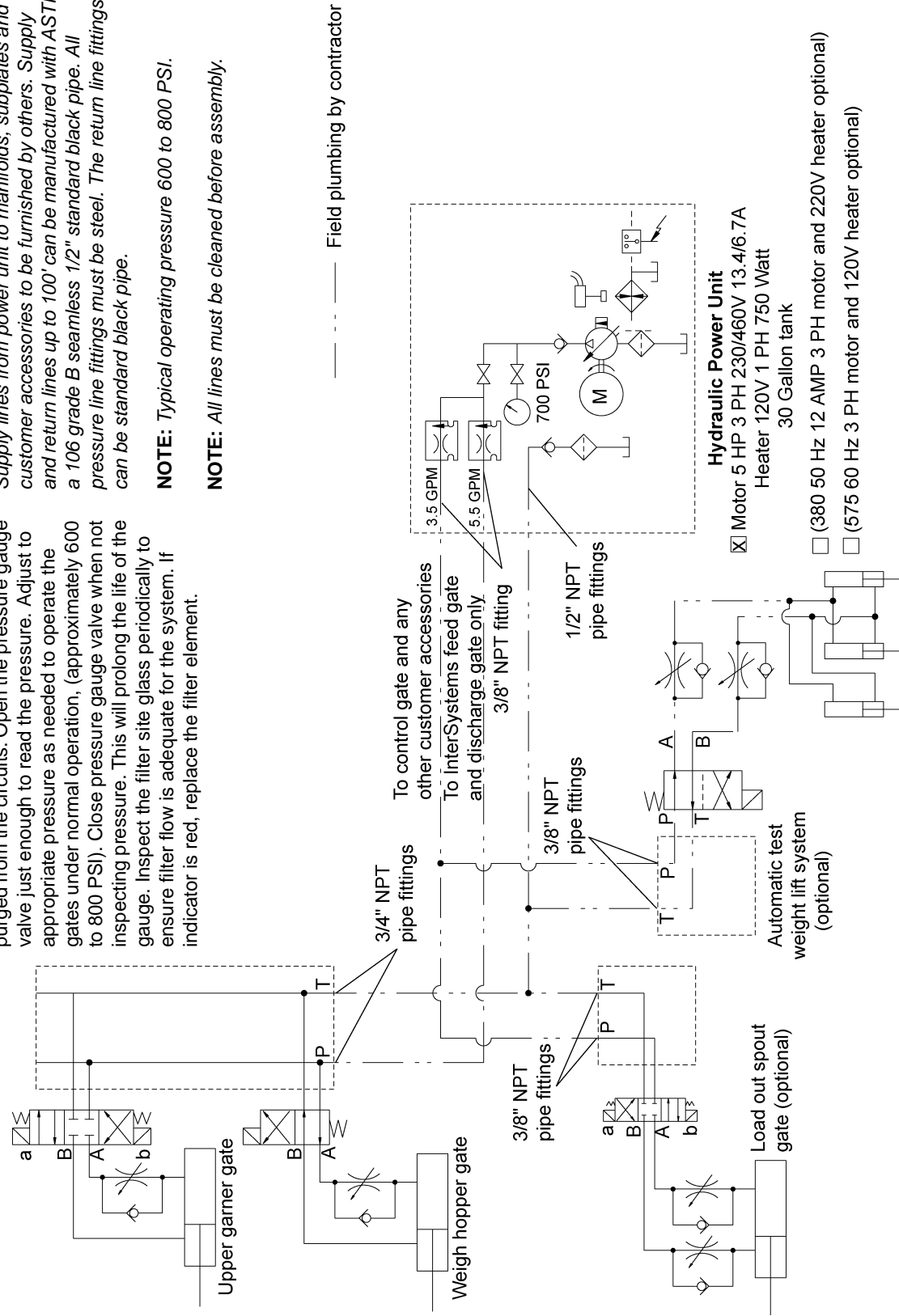

Figure 10B

Hydraulic Schematic 7.5 HP Pressure Compound 1W (532377)

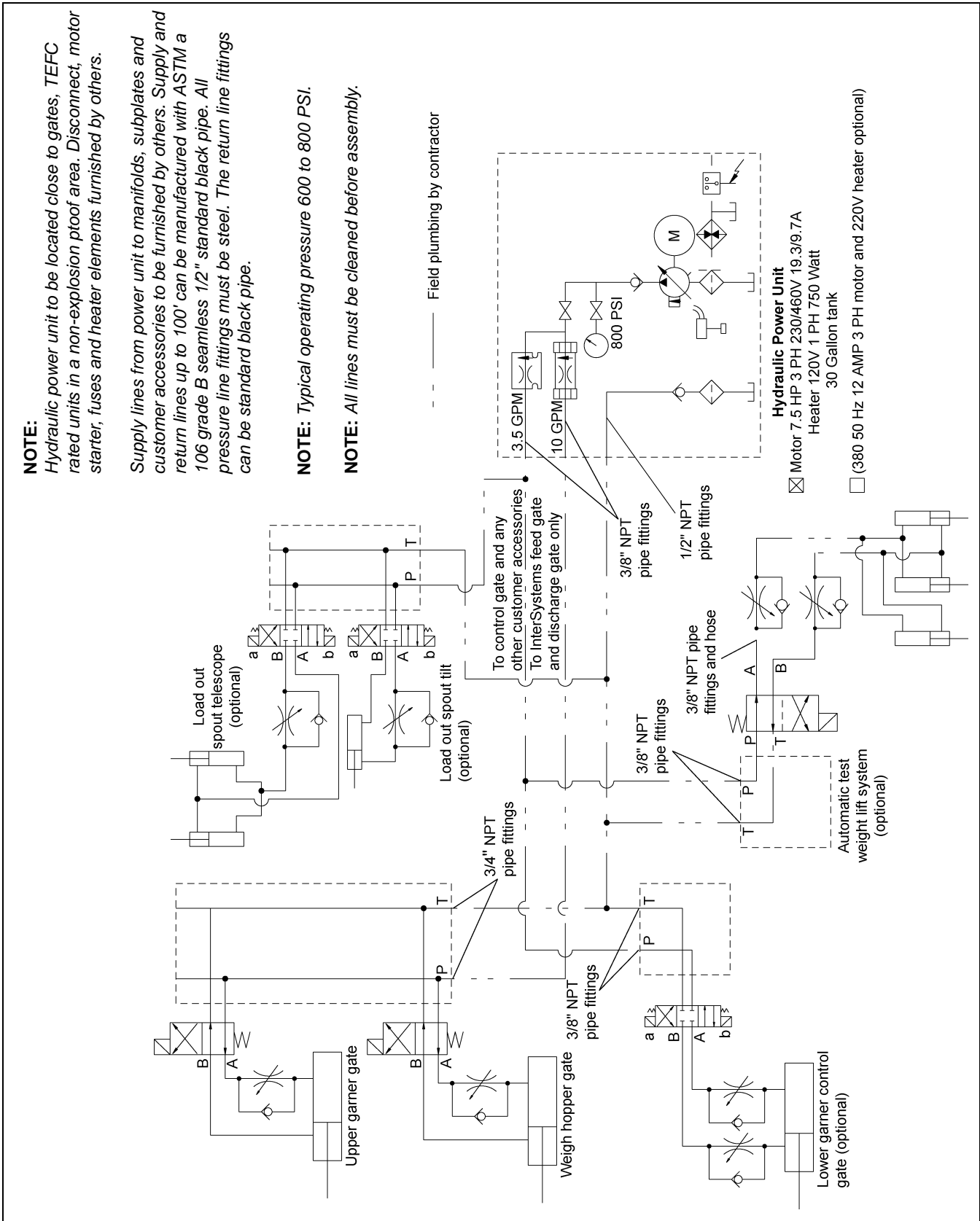

Figure 10C

Hydraulic Schematic 7.5 HP Pressure Compound Trim (732392)

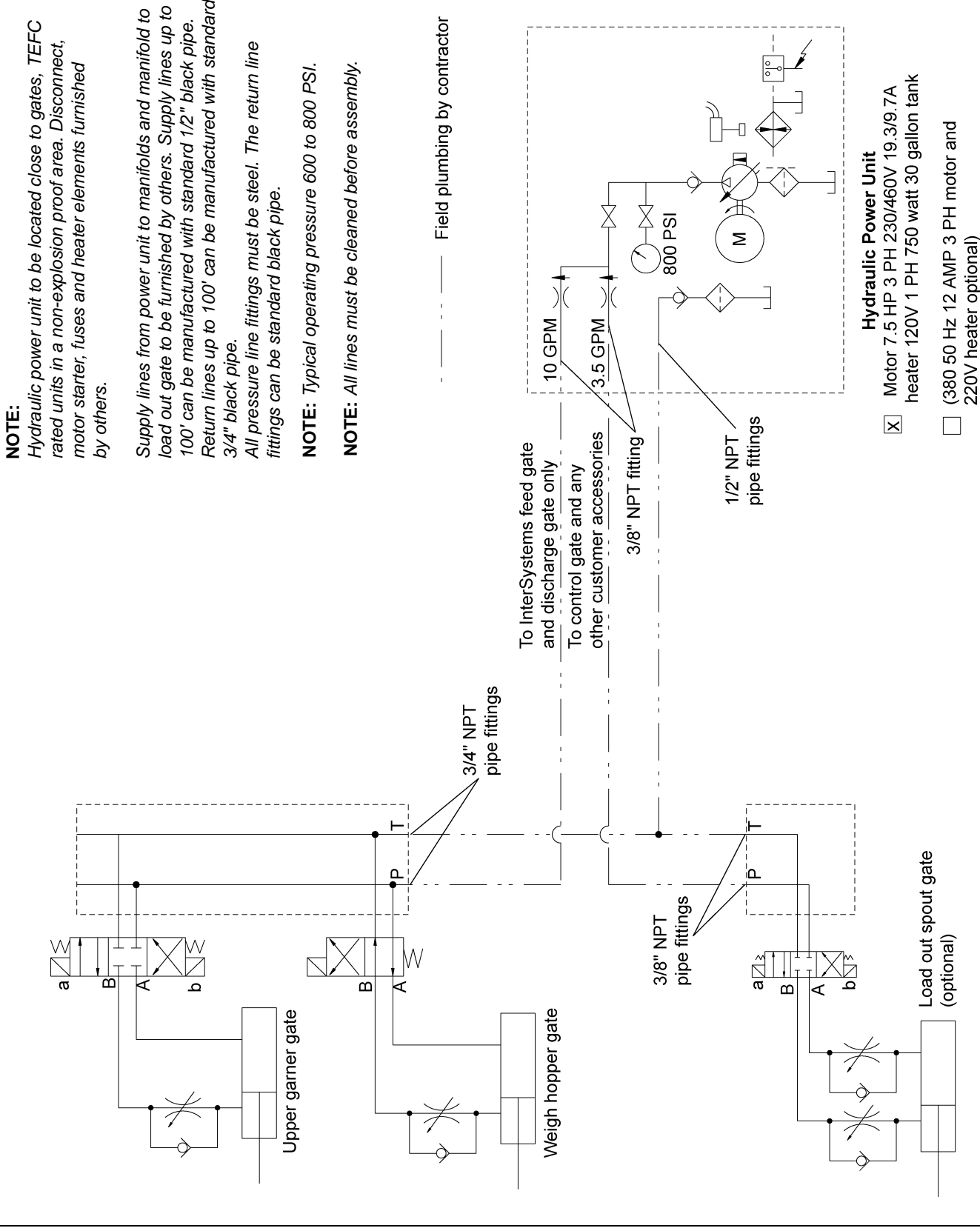

Figure 10D

Electrical System Schematics

Please note that the following drawings are use on standard configurations as listed below. For Custom Bulk Weigher refer to the certified drawings sent with the system. On a factory assembled Bulk Weigher a set of drawings can be found in the electrical termination box.

- If your system has : MasterWeigh, Millennium, Century, or OneWeigh Controller (*Single solenoid on feed gate*) and was factory assembled and has single limit switches on the feed gate and has a single limit switch on the discharge gate.
- Refer to : 531190 Elec Schem Preassembled BW DWI/JAG
531192 MasterWeigh/Jaguar I/O Field Wiring
- If your system has : MasterWeigh, Millennium, Century, or OneWeigh Controller (*Single solenoid on feed gate*) and was field assembled and has single limit switches on the feed gate and has a single limit switch on the discharge gate.
- Refer to : 531191 Electrical Schematics Convensional BW DWI/JAG
531192 MasterWeigh/Jaguar I/O Field Wiring
- If your system has : CompuWeigh (CD2000 of CD3000) (*Dual solenoid on feed gate*) and was factory assembled and has two (2) limit switches on the feed gate and has a single limit switch on the discharge gate.
- Refer to : 526746 BP Electrical Schematics Trim Standard
528116 CD2000 I/O Field Wiring Schematics
- If your system has : CompuWeigh (CD2000 of CD3000) (*Dual solenoid on feed gate*) and was field assembled and has two (2) limit switches on the feed gate and has a single limit switch on the discharge gate.
- Refer to : 526775 BC Electrical Schematics Trim Standard
528116 CD2000 I/O Field Wiring Schematics.

MasterWeigh/Jaguar I/O Field Wiring (531192)

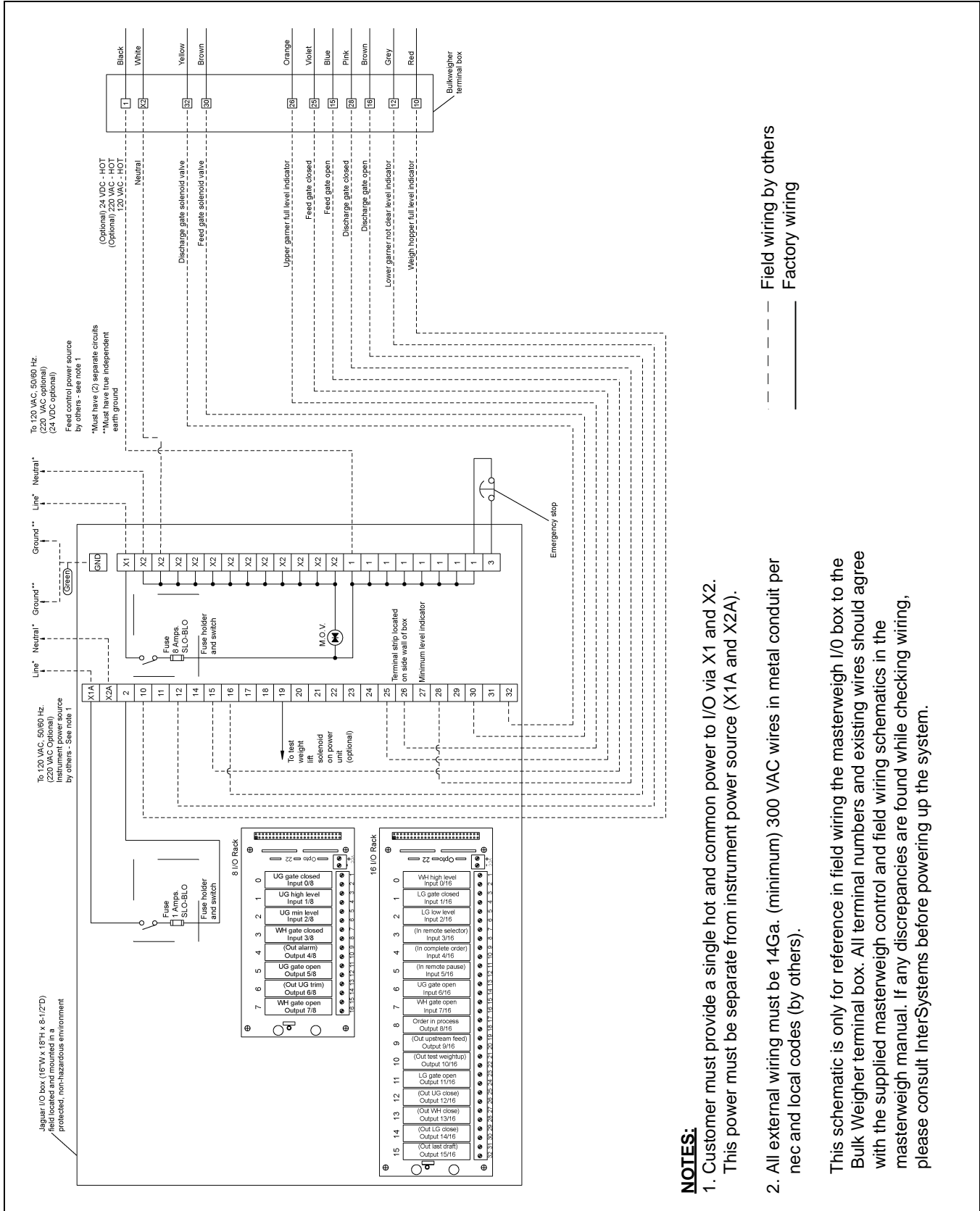

Figure 11A

BP Electrical Schematics Trim Standard (526746)

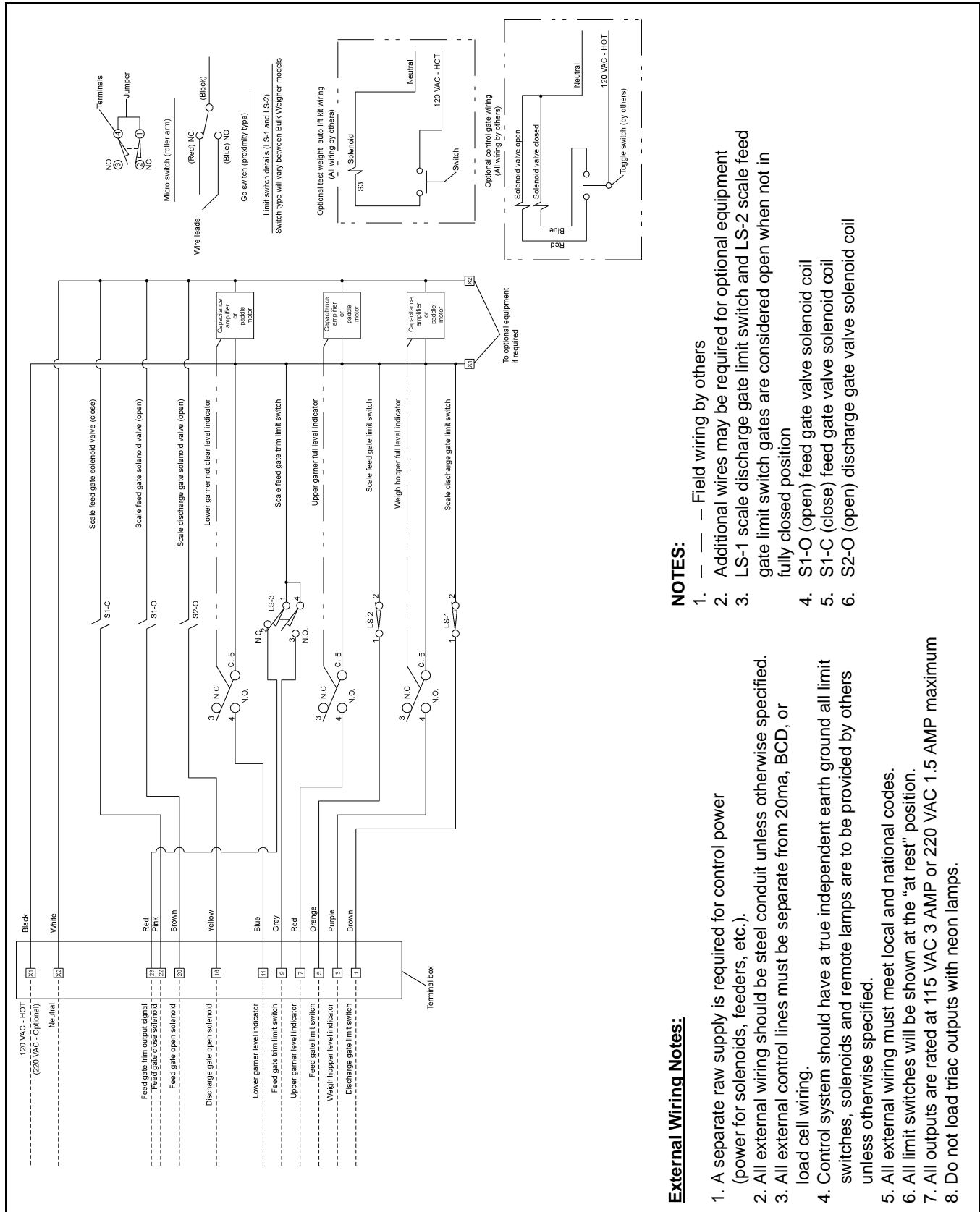

Figure 11B

External Wiring Notes:

1. A separate raw supply is required for control power (power for solenoids, feeders, etc.).
2. All external wiring should be steel conduit unless otherwise specified.
3. All external control lines must be separate from 20ma, BCD, or load call wiring.
4. Control system should have a true independent earth ground all limit switches, solenoids and remote lamps are to be provided by others unless otherwise specified.
5. All external wiring must meet local and national codes.
6. All limit switches will be shown at the "at rest" position.
7. All outputs are rated at 115 VAC 3 AMP or 220 VAC 1.5 AMP maximum
8. Do not load triac outputs with neon lamps.

NOTES:

1. — — — Field wiring by others
2. Additional wires may be required for optional equipment
3. LS-1 scale discharge gate limit switch and LS-2 scale feed gate limit switch gates are considered open when not in fully closed position
4. S1-O (open) feed gate valve solenoid coil
5. S1-C (close) feed gate valve solenoid coil
6. S2-O (open) discharge gate valve solenoid coil

BC Electrical Schematic Standard (526776)

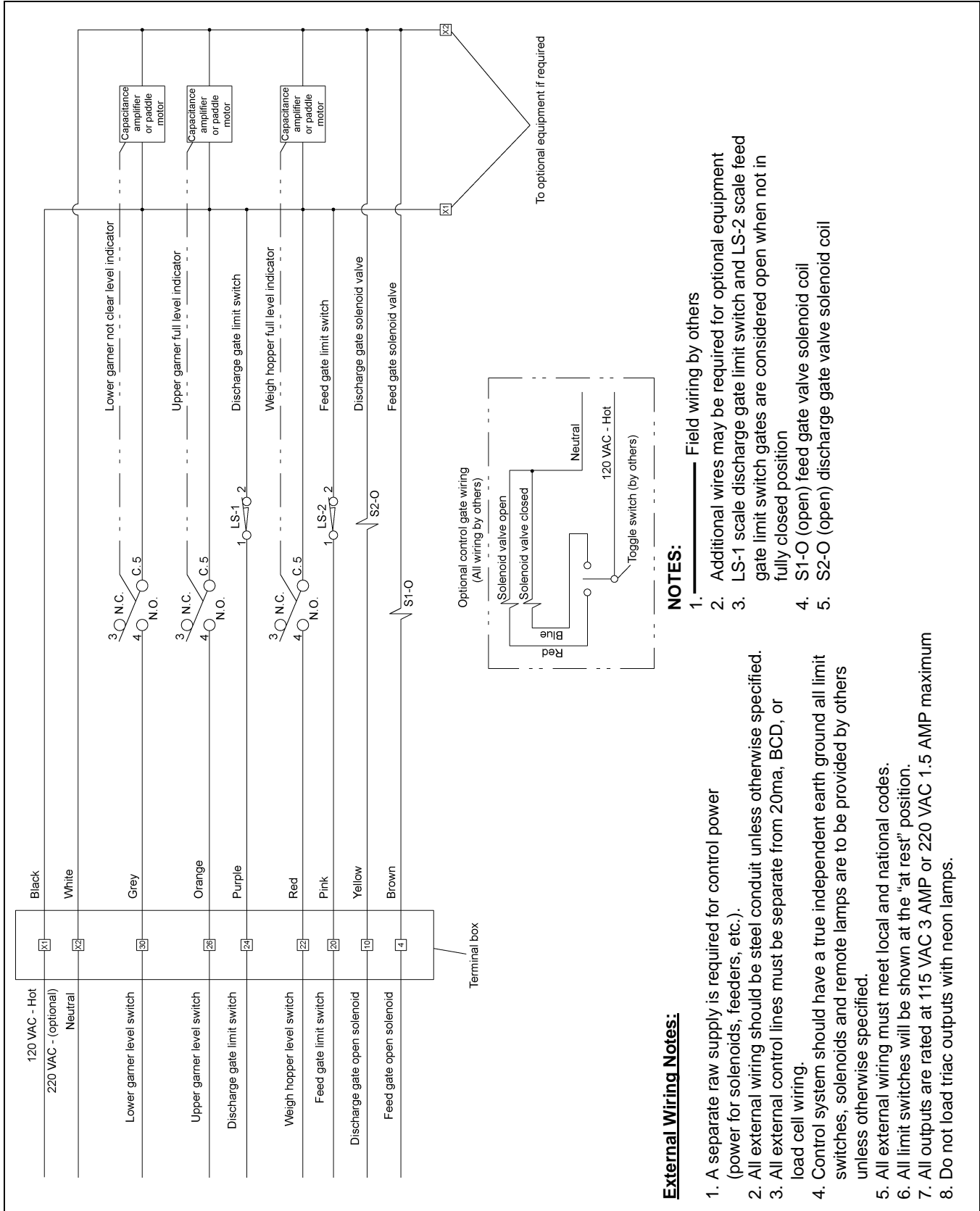

Figure 11C

CD2000 to CD4000 I/O Field Wiring Schematics (528116)

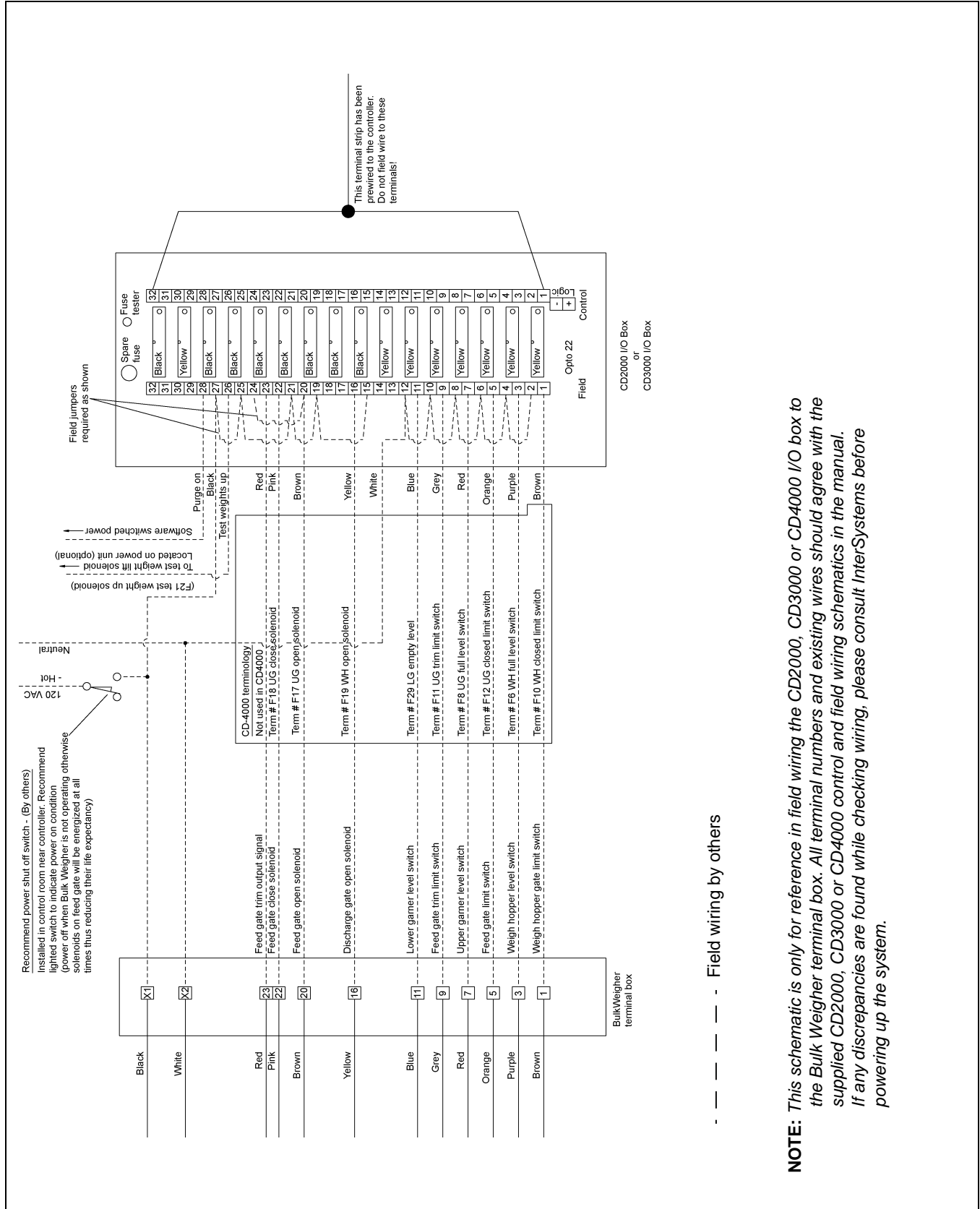

Figure 11D

Description

The Easy Clean (EC) filter bag cleaning system is a simple, highly efficient and robust system. The system sends a jet of compressed air through a pipe to create a shockwave in the filter, which shakes dust and caked-on material off the filter bags.

The filters are supplied without pressure and flow regulators installed. The electrical components are connected to a junction box, installed on the filter top section, ready for cabling to the cleaning control system.

We recommend starting/stopping the jet pulse by a timer or a differential pressure switch.

Features

1. A robust and highly-efficient cleaning system without moving parts.
2. Easy access to the filter bags when replacing.
3. Simple control system means simple setup and adjustment.

Compressed Air

The compressed air supply must be clean and free of oil (ISO/DIN 8573-1 class 3-4-3). Maximum performance is achieved at:

P = min. 2, max. 5 bar.

Air supply formula:

$$Q = \frac{60}{t_p} \times P \times V_{\text{airtank}} \times S_{\text{comp}} \quad [\text{NL/min}]$$

t_p : Pause time - between pulses [s]

P: Cleaning pressure/tank pressure [bar]

V_{airtank} : Air tank volume [L]

S_{comp} : Compressor efficiency ratio [1.5-3]

A DS 12-EC operating in normal condition has an approx. minimum requirement of :

$$Q = \frac{60}{240} \times 3.0 \text{ bar} \times 48\text{L} \times 1.5 = 54 \text{ NL/min}$$

Air Tank	DS-7EC	DS-12EC	BF-8EC	BF-12EC	BF-20EC	BF-34C	BF-55EC	Unit
Volume	13.2	48.0	20.0	2 x 22.5	2 x 22.5	75.0	87.0	Litres
Max. Pressure	8.0	8.0	8.0	8.0	8.0	8.0	8.0	Bar

12. Appendix D - Easy Clean Installation

Recommended Air Supply	DS-7EC	DS-12EC	BF-8EC	BF-12EC	BF-20EC	BF-34C	BF-55EC	Unit
Pressure	3.0	3.0	2.5	3.5	5.0	5.0	5.0	Bar
Flow (T _p - Pause Time 60 s)	120	430	150	470	675	1125	1305	NL/min
Flow (T _p - Pause Time 240 s)	30	108	38	118	169	281	326	NL/min
Flow (T _p - Pause Time 600 s)	12	43	15	47	68	113	131	NL/min

Cleaning Settings	DS-7EC	DS-12EC	BF-8EC	BF-12EC	BF-20EC	BF-34C	BF-55EC	Unit
Min. Cleaning Pressure	2.0	2.0	2.0	2.0	2.0	2.0	2.0	Bar
Normal Cleaning Pressure	3.0	3.0	2.5	3.5	5.0	5.0	5.0	Bar
Recommended Max. Cleaning Pressure	5.0	5.0	5.0	5.0	5.0	6.0	6.0	Bar
Electrical On-Time for Diaphragm Valve	0.2	0.2	*	*	*	*	*	s
Pause Time (T _p)	240	240	240	240	240	240	240	s
Shut Down Cleaning Cycles	1	1	1	1	1	1	1	#

* See section proposed cleaning control system [on Page 93](#) as the on-time depends on bag length.

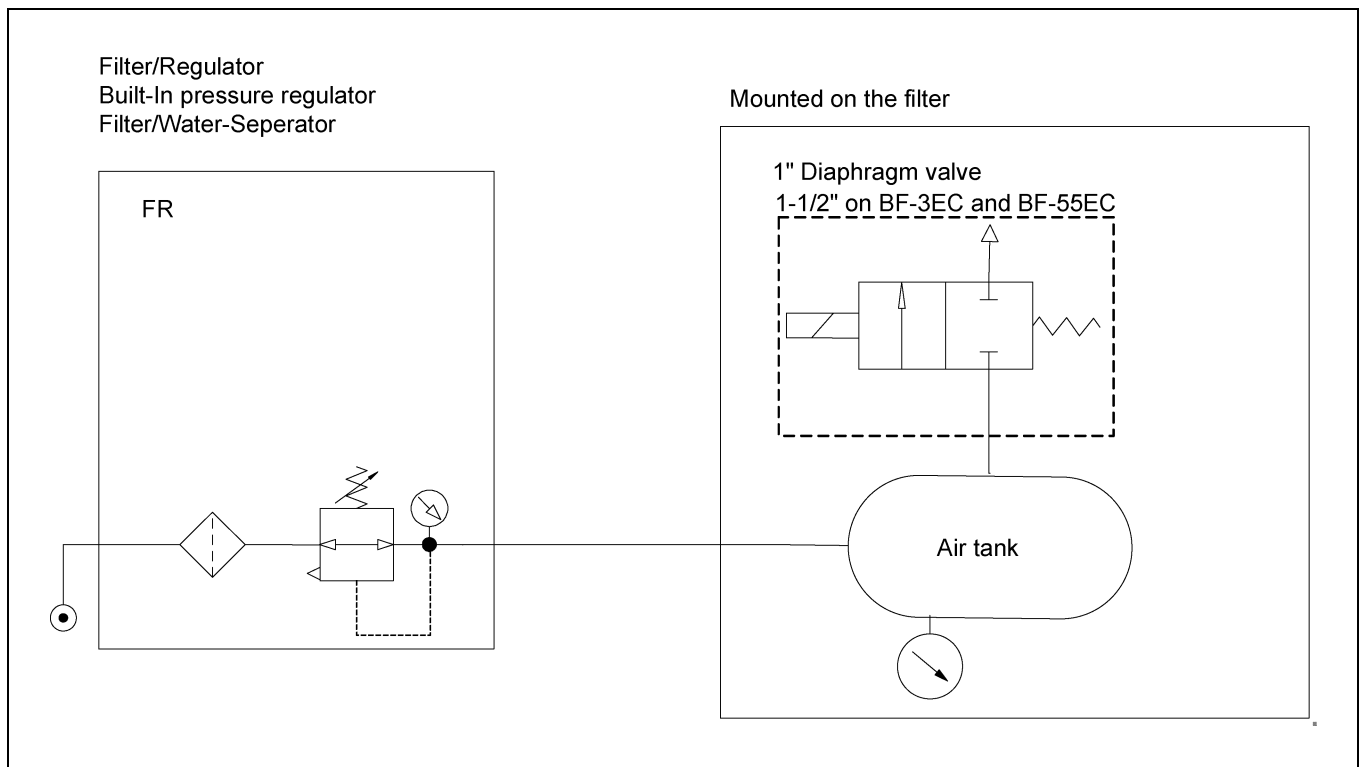

Figure 12A

Electrical Connections

All cables from the diaphragm valve coils are connected in a junction box. The optional door safety switch can also be connected here.

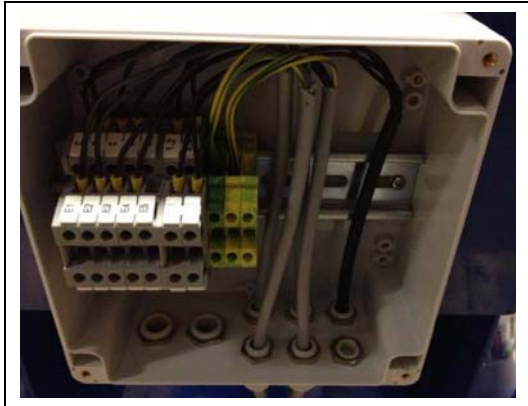

Figure 12B Junction Box with Marked Terminals

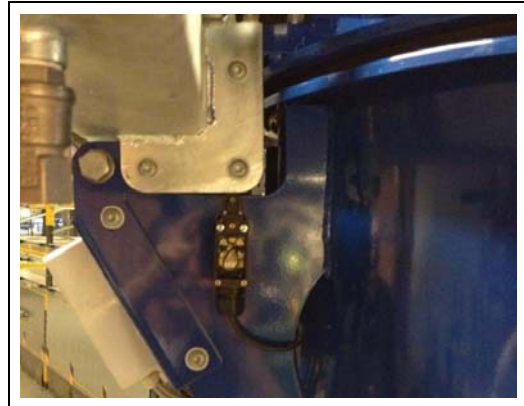

Figure 12C Door Safety Switch

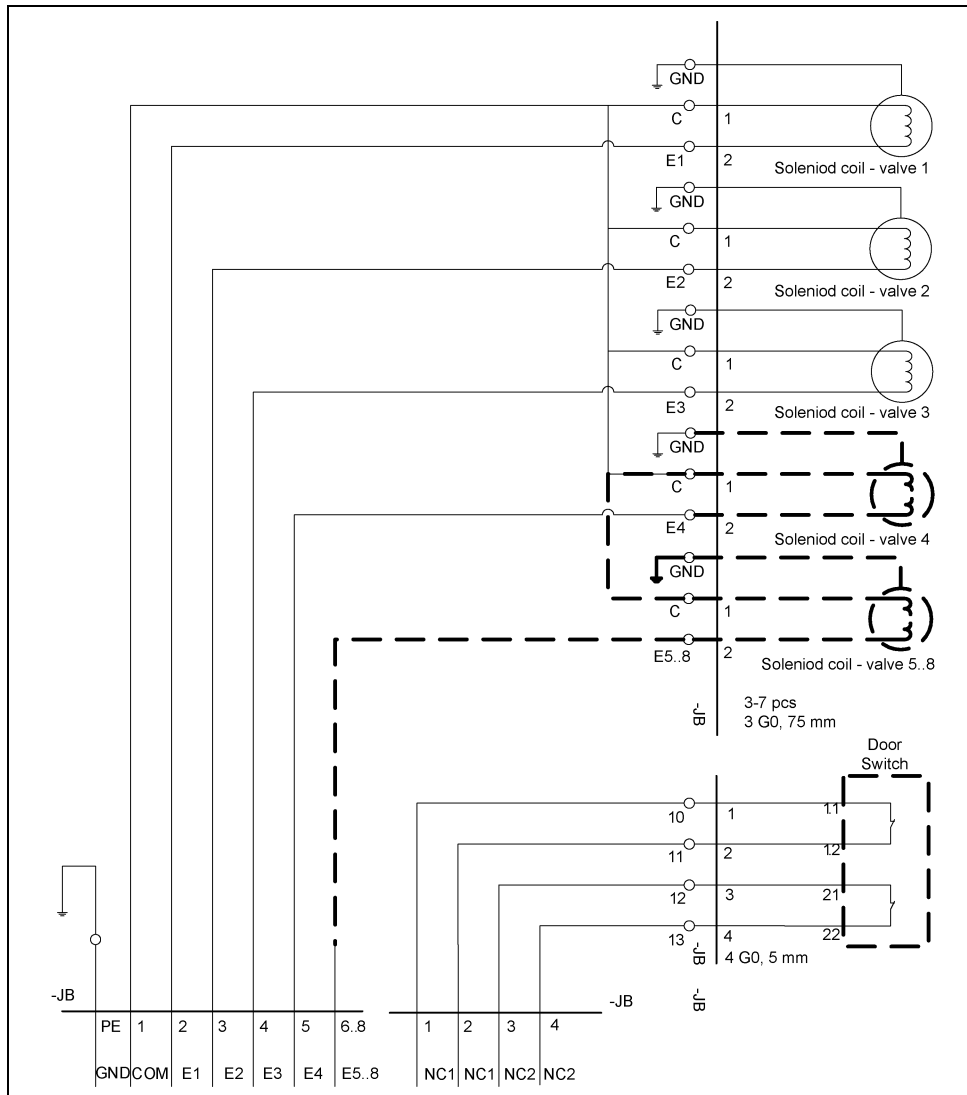

Figure 12D

12. Appendix D - Easy Clean Installation



Figure 12E

Electrical Characteristics - Solenoid	
Coil Insulation	Class H
DIN Socket Connector	PG9 Connection
DIN Socket	94/9CE ATEX II 3GD T6
Insulation Class DIN Socket	VDE 0110 - 1/89
Electrical Protection	IP65 EN60529
Voltage	24V DC - 12 W
Ambient Temperature	-20°C / +60°C

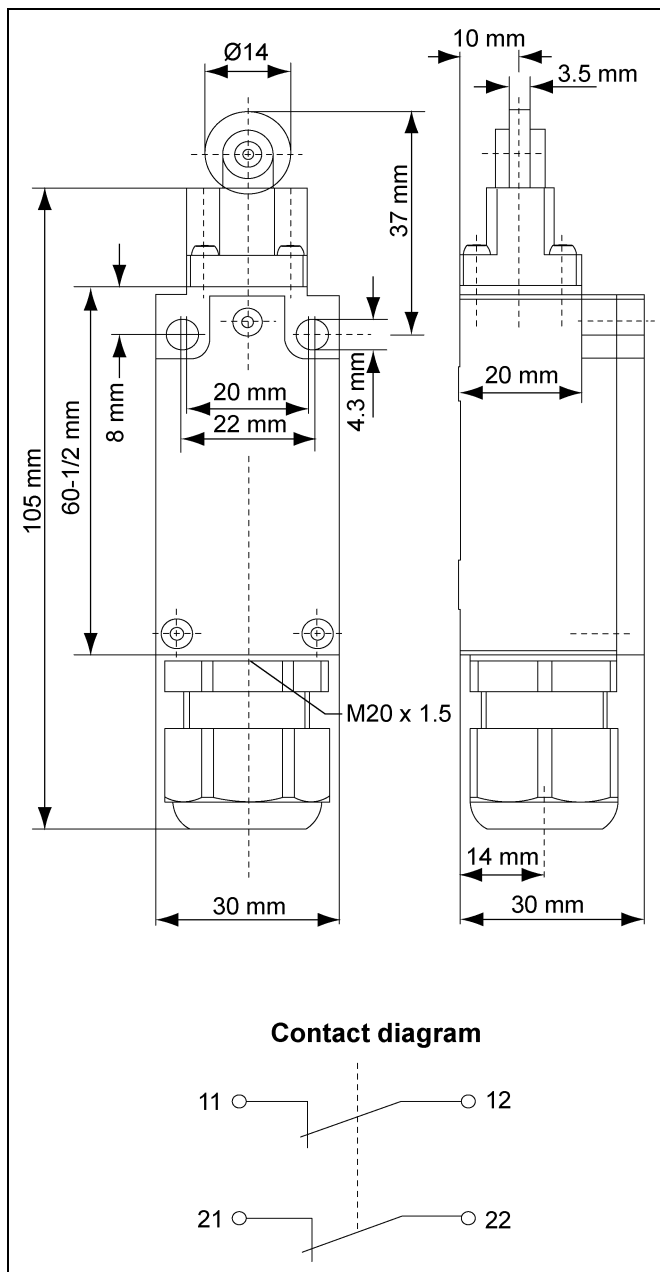

Figure 12F

Technical Data	
Standards	EN60947-5-1;EN1088 EN60079-0, EN60079-1 EN60079-7;EN61241-0 EN61241-1;EN ISO 13849-1
Design	DIN EN 50 047
Enclosure	Glass-Fibre Reinforced, Shock-Proof Thermoplastic Self-Extinguishing UL 94-V0
Switch Insert	Ex 95
Degree of Protection	IP 67 to IEC/EN 60529
Contact Material	Silver
Switching System	Slow Action, Positive Break NC Contact
Switching Elements	2 NC Contacts with Double Break Zb, Galvanically Separated Contact Bridges
Connection	M3 Screw Clamps
Cable Section	Max 1.5 mm ² (Incl. Conductor Ferrules)
B _{10d} (10% Load)	2 Million
T _M	max. 20 Years
U _{imp}	4 kV
U _i	250V
I _{the}	6A
I _e /U _e	6A/250 VAC;0.25 A/230 VDC
Utilisation Category	AC-15, DC-13
Max. Fuse Rating	6A g _L /g _D D-Fuse
Ambient Temperature	-20°C...+60°C
Mechanical Life	>1 Million Operations
Switching Frequency	3600/h
Repeat Accuracy	±0.1 mm
Contact Gap	max. 2 x 3.5 mm
Ex Marking	Ex II 2G Ex de IIC T6 Ex II 2D Ex td A21 IP67 T80°C
Approvals	DMT 01 ATEX E118 IECEX in 2011

Proposed Cleaning Control System

The EC filter is either supplied with a simple cleaning MTS control system, which facilitates:

1. Manual selection of pulse and pause times.
2. Remote start/stop cleaning cycle by pressure switch or PLC.
3. Set number of shut down cleaning cycles.

Or with a simple cleaning MTS control system, which further facilitates:

1. Automatic start/stop by differential pressure measuring.
2. Precoating function (delayed cleaning of bags).
3. Alarm at too high differential pressure.
4. Hour timer.
5. 4-20 mA DP signal to main control (option).

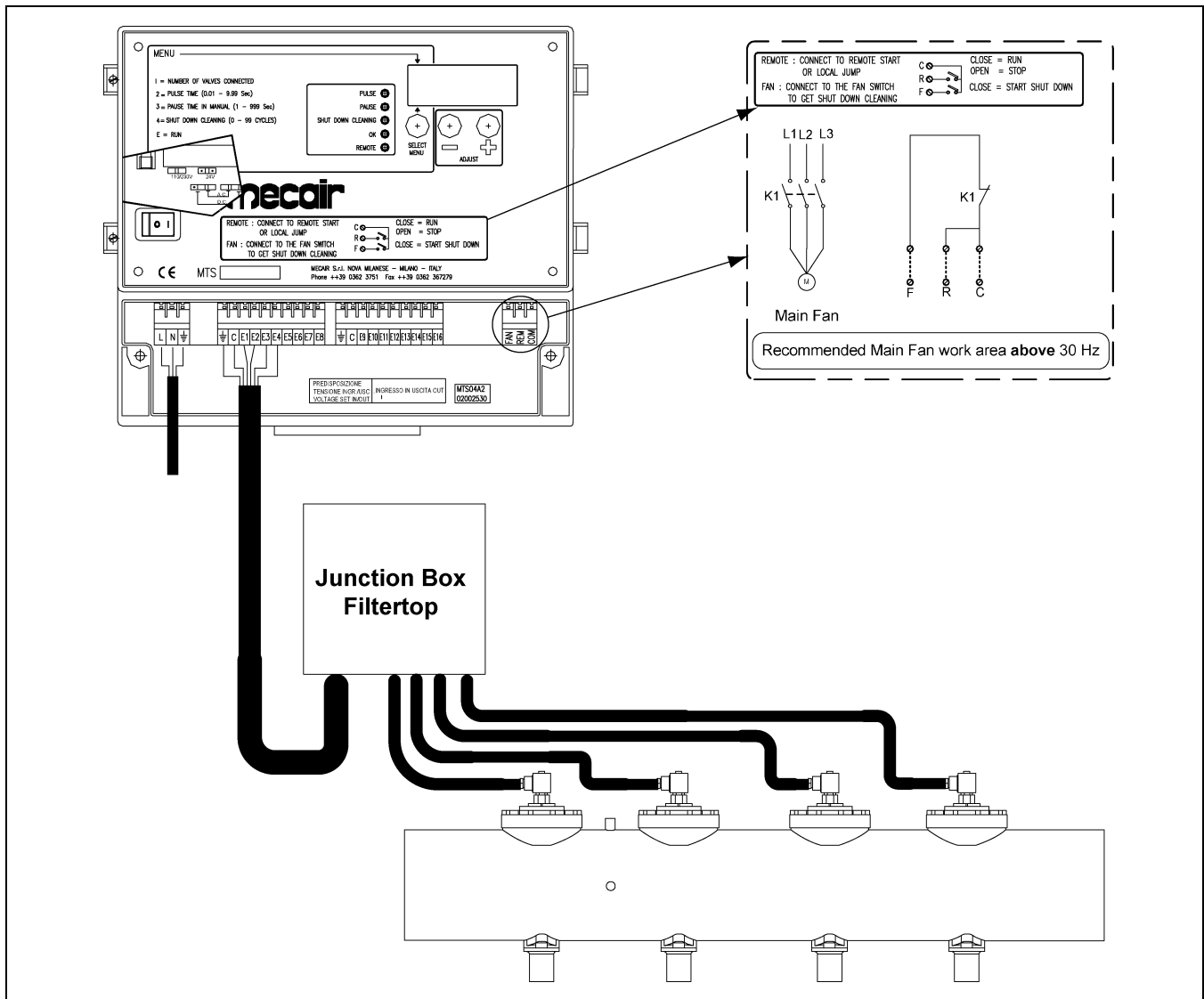

Figure 12G Connection of MTS/MPS Control System to EC

12. Appendix D - Easy Clean Installation

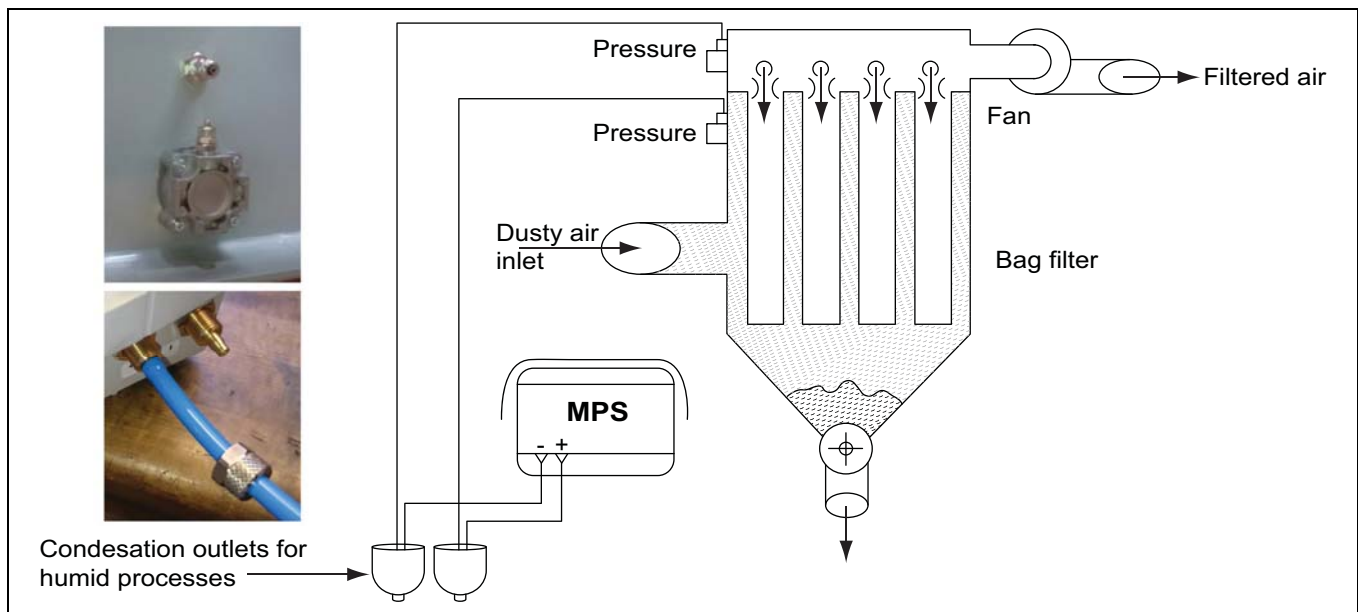

Figure 12H Connection of MTS/MPS Control System to EC

Shut down cleaning is the most important cleaning cycle. Ensure that power and air supply to the MTS/MPS control system are not disconnected before shut down cleaning has been carried out.

MTS Settings	DS-7EC	DS-12EC	BF-8EC	BF-12EC	BF-20EC	Unit
1 = Number of Valves Connected	3	4	4	4	5	#
2 = Pulse Time (0.01 - 9.99 Sec)	0.2	0.2	See Below	See Below	See Below	s
3 = Pause Time in Manual (1 - 999 Sec)	240	240	240	240	240	S
4 = Shut Down Cleaning (0-99 cycles)	1	1	1	1	1	#
E = Run						

MPS Settings	BF-34EC	BF-55EC	Unit
1 = Manuel/Automatic	1	1	0 Manual 1 Automatic
2 = Number of Valves Connected	6	7	#
3 = Pulse Time (0.01 - 9.99 sec.)	See Below	See Below	s
4 = Pause Time in Manual (1 - 999 sec.)	240	240	s
5 = Pause Time in Automatic (1 - 999 sec.)	240	240	s
6 = Operating DP (0.01 - 3.00 KPa) - Start Cleaning	1.00	1.00	KPa
7 = Delta-P Alarm (0.01 - 3.00 KPa)	2.5	2.5	KPa
8 = Shut Down Cleaning (0-99 Cycles) Only runs in automatic and if operating DP has been exceeded	1	1	#
9 = DP Precoat (0.01 – 3.00 kpa)	0	0	KPa
C = Adjustment of 4 mA (See MPS Manual)	190		
F = Adjustment of 20 mA (See MPS Manual)	750		
L = Operating Hours (0-999 h) 12.270 h = 270			h
H= Operating Hours (1-65 x 1000 h) 12.270 h = 12			X 1000 h
0000 = Reset of DP (Runs when the filter is not operating - evt. without hoses on the control)			
E = Run			

12. Appendix D - Easy Clean Installation

Shut down cleaning is the most important cleaning cycle. Ensure that power and air supply to the MTS/MPS control system are not disconnected before shut down cleaning has been carried out.

Pulse Time	BF-EC	Unit
Filter Bag Length 1.5 m	0.06	s
Filter Bag Length 2.0 m	0.08	s
Filter Bag Length 2.5 m	0.1	s
Filter Bag Length 3.0 m	0.12	s
Filter Bag Length 3.5 m	0.16	s
Filter Bag Length 4.0 m	0.20	s

Options

Optional extras for EC filters.

Article No.	Description 1	Description 2
8251911	Manometer 0-10 Bar	For Midi F/R15
8251955	½" Reduction Valve + Water Filter	Midi F/R15b / BES
82532101006	Hexagonal Nipple	A1-1/4"-1/2"
8244019	Electrical Control System	DS-7 MTS4
82440191	Electrical Control System	MTS8
8252309	Position Switch for Top	Ex 95 RL 2Ö 3D

13. Appendix E - Electronic Sequencer (Model MTS)

Technical Characteristics

Enclosure	ABS Grey - Transparent Cover		
Protection Rating	IP65		
Dimensions	MTS 4/8/12/16 Outlets: Enclosure 213 x 185 x 113 mm		
Weight	Approx. 2 kg All Models		
Connections	Push in Terminal Blocks - Max. Section 2,5 mm ²		
Temperature	Storage: -20°C/+80°C. Operation: -10°C/+50°C, with Duty Cycle 30%.		
Voltages Available	CODE	INPUT	OUTPUT
	P1	230V (±20%) - 50/60 Hz	230V - 50/60 Hz
	P3	115V (±20%) - 50/60 Hz	115V - 50/60 Hz
	P3D	115V (±20%) - 50/60 Hz	115 VDC
	P4	230V (±20%) - 50/60 Hz	24V - 50/60 Hz
	P4D	230V (±20%) - 50/60 Hz	24 VDC
	P5	115V (±20%) - 50/60 Hz	24V - 50/60 Hz
	P5D	115V (±20%) - 50/60 Hz	24 VDC
	P6	24V (±10%) - 50/60 Hz	24V - 50/60 Hz
	P6D	24V (±10%) - 50/60 Hz	24 VDC
Power	Without Outlet: 2,5 VA. Outlet: 30 VA - 15W		
Pulse Time	0,01 ÷ 9,99 sec.		
Pause Time	1 ÷ 999 sec.		
Remote Control	Activated via external contact (normally open) free of power.		
Shut Down Cleaning	1 - 99 cycles. To be operated from the normally closed contact of fan remote control switch.		
Fuse	1A delayed (W). 2A delayed (X).		

Features

The Model "MTS" has been designed to guarantee the control of diaphragm valves mounted on pulse jet dust collector filters containing filter bags or cartridges. MTS main features are:

1. Manual selection of Pulse and Pause Time.
2. Can be operated by a remote pressure switch or PLC.
3. Shut down cleaning with selectable number of cycles.

NOTE: Refer to General Assembly Parts List [on Page 103](#).

Installation

1. Do not place MTS in direct sunlight in order to avoid overheating of circuit board.
2. Protect MTS from rain, water infiltration and humidity. Make sure that all cover screws are properly tightened in order to avoid any infiltration that may seriously damage the circuit board.
3. Do not allow cables to enter from the top of the MTS enclosure. It is also advisable to shape the initial part of the MTS cable clamp into an upright “U” in order to prevent water or condensate to enter the box.
4. Avoid installing any electronic devices on vibrating structures.
5. In case you select SHUT DOWN CLEANING, connect MT to a continually powered line.
6. A broken MTS has to be considered as an industrial waste and treated as such. Do not burn it in incinerator as toxic gases may be released and condensers may explode.
7. In case of malfunction do not try to repair MTS. Please call customer assistance.
8. All wiring has to be carried out by a professional electrician in order to guarantee the correct operation of the unit and in order to avoid malfunctioning.
9. Always make sure that MTS does not have power connected before carrying out any maintenance. (ON/OFF switch (F) on 0 and terminals (G) disconnected.)
10. All electrical cables to and from MTS unit should be isolated from other wiring.

Preliminary Checks

1. Check that MTS does not have power. (ON/OFF switch (F) on 0 and terminals (G) disconnected.)
2. Check that the power supply indicated by the yellow label (U) as “INGRESSO-IN”, corresponds to the available power supply. (Voltage and Frequency.)
3. Check that the power supply to valves indicated by the yellow label (U) as “USCITA-OUT”, corresponds to the voltage/frequency as indicated on the coils.

Electrical Connections of the Valves

1. Unscrew and open the terminal blocks (N).
2. Check that MTS does not have power. (ON/OFF switch (F) on 0 and terminals (G) disconnected.)
3. Extract the removable terminals (J).
4. Check that the power supply to valves indicated by the yellow label (U) as “USCITA-OUT”, corresponds to the voltage/frequency as indicated on the coils.
5. Connect the valves to the terminal blocks (N), between terminal C and the numbered outlets.
 - a. Earthing (K) of the valves is necessary when outlet voltage is = or > 48V.
 - b. NEVER connect the common or valve outlet to ground (K).
 - c. The commons are interconnected on the printed circuit board.
 - d. The outlets are “static” type, with “zero crossing” command, to prevent electrical disturbances.

NOTE: Refer to General Assembly Parts List on Page 103.

13. Appendix E - Electronic Sequencer (Model MTS)

6. Check that the valve connections are correct and isolated in regard to round, by measuring the isolation between ground (K) and common with outlets terminal.
7. Close the terminals and replace the screws (R).

Start-Up

Voltage Selection

Check that MTS does not have power. (ON/OFF switch (F) on 0 and terminals (G) disconnected.)

1. Check that the power supply indicated by the yellow label (U) as “INGRESSO-IN”, corresponds to the available power supply. (Voltage and Frequency.)
2. Check that the power supply to valves indicated by the yellow label (U) as “USCITA-OUT”, corresponds to the voltage/frequency as indicated on the coils.

If the above conditions correspond go to section Selection of Parameters [on Page 99](#).

If not, follow the procedure below.

Power Supply Selection

1. Unscrew the two (2) screws (R) and open the MTS transparent cover.
2. Remove the four (4) screws of the green panel. Lift the green panel. (Without taking it away.)
3. Check that power supply selected by jumper (H), corresponds to the one available from the power supply. (ex: both 230V.)
4. Should the two voltages be different, replace jumper (H) in order to select the same power supply required.
5. Refer to selection of power supply to the valves section [below](#).

Selection of Power Supply to the Valves

1. Check that power supply to the valves, selectable by jumpers (L), corresponds to power supply indicated on the coils of the valves. (ex: both 230V.)

Jumper (L): 1HV=110V 2HV=220V LV=24V

Jumper (L): HV=110/220V LV=24V

2. Should the two voltages be different , replace the jumpers (L) in order to select the same power supply indicated on the coils.

Jumper (L): 1HV=110V 2HV=220V LV=24V

Jumper (L): HV=110/220V LV=24V



Both of the jumpers (L) must correspond to the same voltage.

NOTE: Refer to General Assembly Parts List [on Page 103](#).

3. Refer to selection of power supply frequency to the valves section [below](#).

Selection of Power Supply Frequency to the Valves (AC/DC)

1. Make sure that the outlet frequency to the valves, selected by jumper (M), corresponds to the value indicated on the coils. (ex: both AC.)
2. Should the two frequencies be different, replace jumper (M) in order to select the same frequency indicated on the coils.
3. Replace the green panel with its four (4) screws.
4. Close the transparent cover by means of the two (2) screws (R).



Never select 230 VDC for the outlet.

Selection of Parameters

Connecting the power supply (G):

1. When 230V (L = phase, N = neutral).
2. When 115V (L = phase, N = neutral)
3. When power supply from auxiliary transformers (coils, remote control switches, etc.) it is mandatory to earth one of the two (2) terminals of the secondary and to connect it to N.

ON/OFF switch (F) on 1. The display (O) will indicate for 3 seconds the release code of MTS. Once the code disappears, display will show letter E (Run) and the number of the valve which is going to be operated. LED OK (D) and REMOTE (E) are ON.

1. Press SELECT MENU (I): 1 will flash on display (O) :
 - Using keys +/- (P) select the N° OF VALVES you wish to connect. Example: If you wish to connect 6 valves to MTS, select 6. Should you skip this step of the MENU, MTS will automatically set no. of valves as if they were all connected, (if your model is MTS4) then eight valves will be recognised, (if your model is MTS8) then eight valves will be recognised.
2. Press SELECT MENU (I): 2 will flash ON (O) :
 - Using keys +/- (P) select PULSE TIME. (0, 01 ÷ 9,99s)
3. Press SELECT MENU (I): 3 will flash on display (O) :
 - Using keys +/- (P) select PAUSE TIME. (1 ÷ 999s)
4. Press SELECT MENU (I): 4 will flash on display (O) :
 - Using keys +/- (P) select N° OF CYCLES of SHUT DOWN CLEANING.
Select 0 if you do not wish to have shut down cleaning.
PAUSE TIME in SHUT DOWN CLEANING is the same as the one selected at point 3 above.

NOTE: Refer to General Assembly Parts List [on Page 103](#).

13. Appendix E - Electronic Sequencer (Model MTS)

5. Press SELECT MENU (I) : E1 will flash on display (O) the cleaning cycle starts.

LED 1 (A) will indicate that a valve is being pulsed.

LED 2 (B) will indicate that MTS is waiting to pulse the next valve.

N.B.:

- Valves are pulsed from outlet n° 1 onward.
- Check that during the first cleaning cycle every valve is pulsed.
- We suggest setting the MTS working parameters in order to clean the filter with the lowest possible frequency in order to reduce dust emissions due to bag stress, to achieve a longer lifetime of the bags and to reduce compressed air consumption.
- PAUSE TIME should allow an efficient filter cleaning in the worst conditions, but should never be shorter than time needed to re-pressurise the header tank.
- While selecting parameters (in SELECT MENU), MTS will return functioning if buttons are not pressed within a three minutes interval.

Remote



MECAIR fits the MTS unit with a bridge on terminals REMOTE (S) and COMMON (T).

If you wish to operate MTS with a remote switch ,read instructions below. If you do not wish to take advantage of this opportunity, do not remove the bridge to prevent MTS from going into block mode.

To activate REMOTE:

1. Unscrew and open the terminal blocks (N).
2. Remove the bridge from terminal REMOTE (S) and COMMON (T).
3. Bring an external no-load and normally open (NO) contact to REMOTE (S) and COMMON (T) terminals from an external device (example: contact from DP monitor).
4. Close and screw the terminal blocks (N).
5. Close the contacts on the REMOTE (S) and COMMON (T) terminals in order to enable the REMOTE function.
6. Should you open the contact on REMOTE (S) and COMMON (T), MTS will stop working, display will show SB (stand by) and REMOTE (E) and PAUSE (B) led will be OFF. Close the contact in order to start cleaning cycle again from the position it stopped.

NOTE: Refer to General Assembly Parts List [on Page 103](#).

Shut Down Cleaning

We suggest operating on or more cycles of SHUT DOWN CLEANING at the end of each working session in order to remove the residual dust of the filter. SHUT DOWN CLEANING is started each time the fan is switched OFF.

In order to activate SHUT DOWN CLEANING:

1. Select the number of cycles in SHUT DOWN CLEANING.
2. Unscrew and open the terminal blocks (N).
3. Bring an external no-load and normally close (NC) contact to terminals FAN (Q) and COMMON (T) from the fan switch.
4. Close and screw the terminal blocks (N).
5. Close the contact on the FAN (Q) and COMMON (T) terminals in order to start SHUT DOWN CLEANING each time that fan is switched OFF. The present cleaning cycle will be considered as the first cycle of SHUT DOWN CLEANING.



If 0 is selected on the menu, MTS will stop working as soon as the contact on terminal FAN (Q) and COMMON (T) are closed.

LED 3 (C) will flash during SHUT DOWN CLEANING.

6. At the end of SHUT DOWN CLEANING LED 3 (C) will remain ON and the display will show E1. Switch the fan ON in order to start cleaning cycle again and to switch LED 3 (C) OFF.

Troubleshooting

Problem	Probable Cause	Solution
Display is blank and all LED are OFF.	No power supply.	Check the fixing of the power supply terminals (G).
Some valves are ignored.	Wrong electrical connections between MTS and coils.	Check connections (J).
	Coils are interrupted.	Check coils continuity.
Display shows the pulsing sequence but valves are not functioning.	The secondary of the transformer is interrupted.	Contact MECAIR
	Power circuit is damaged.	Contact MECAIR
	Power supply to valves is different from voltage indicated on the coils.	Check or re-select power supply voltage. Refer to selection of power supply to the valves section on Page 98 .
	Wrong connection between MTS and valves.	Check connections (J).
LED OK (D) is OFF.	Microprocessor failure.	Contact MECAIR

NOTE: Refer to General Assembly Parts List [on Page 103](#).

General Assembly (MTS 4-16)

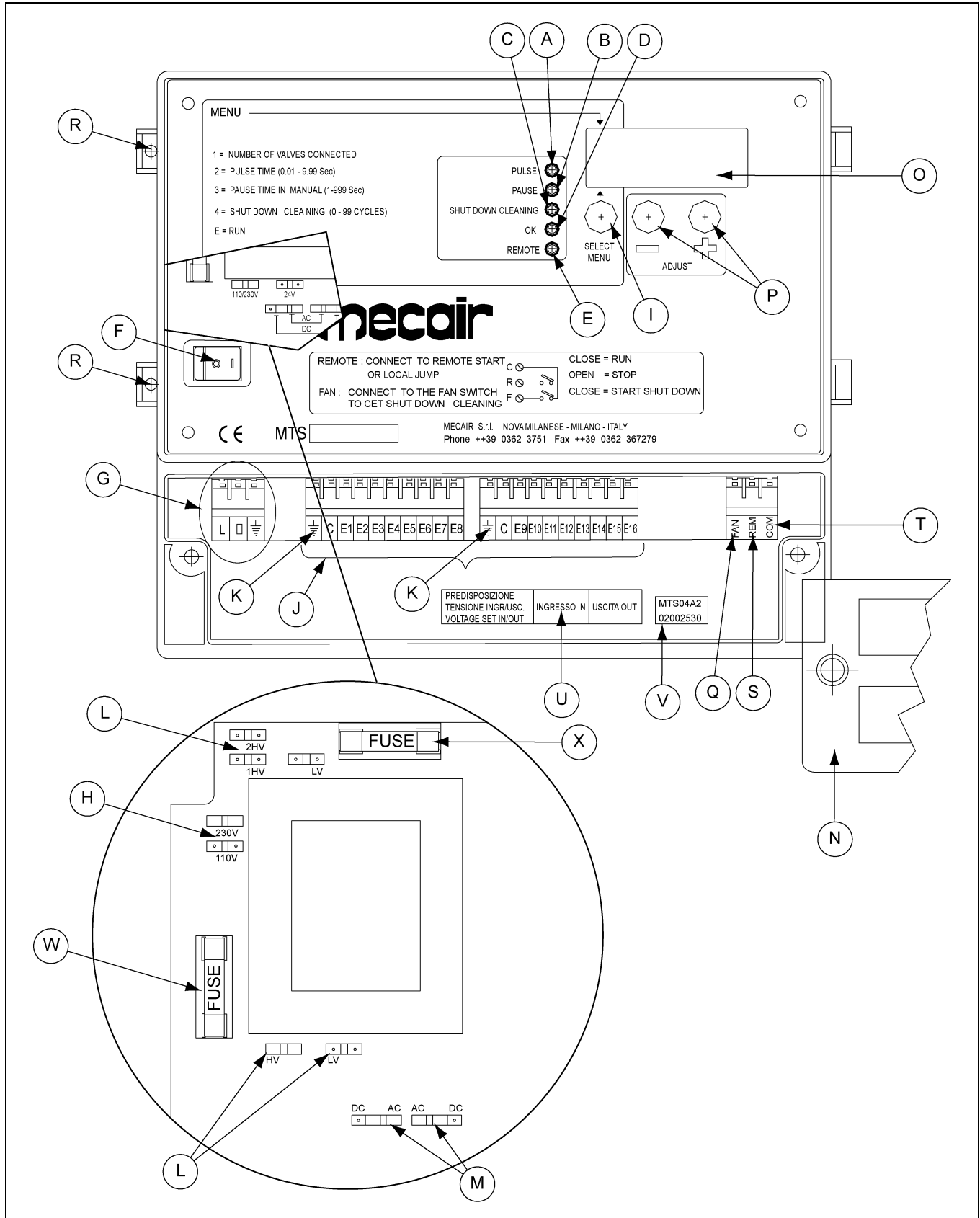

Figure 13A

13. Appendix E - Electronic Sequencer (Model MTS)

General Assembly (MTS 4-16) Parts List

Ref #	Description
A	LED Pulse
B	LED Pause
C	LED Shut Down Cleaning
D	LED OK
E	LED Remote
F	ON/OFF Switch
G	Power Supply Terminals
H	Jumper for Inlet Power Supply Selection
I	Push Button Select Menu
J	Push in Terminals
K	Valves Earthing
L	Jumper for Voltage Selection to Valves
M	Jumper for the Frequency Selection to Valves (A.C./D.C.).
N	Terminal Blocks
O	Display
P	Push Buttons +/-
Q	Fan Terminal
R	Transparent Cover Fixing Screws
S	Remote Terminal
T	Common Terminal
U	Yellow label indicating IN/OUT Voltage/Frequency
V	Product Code and Serial Number
W	Fuse 1A
X	Fuse 2A

MTS Front Panel

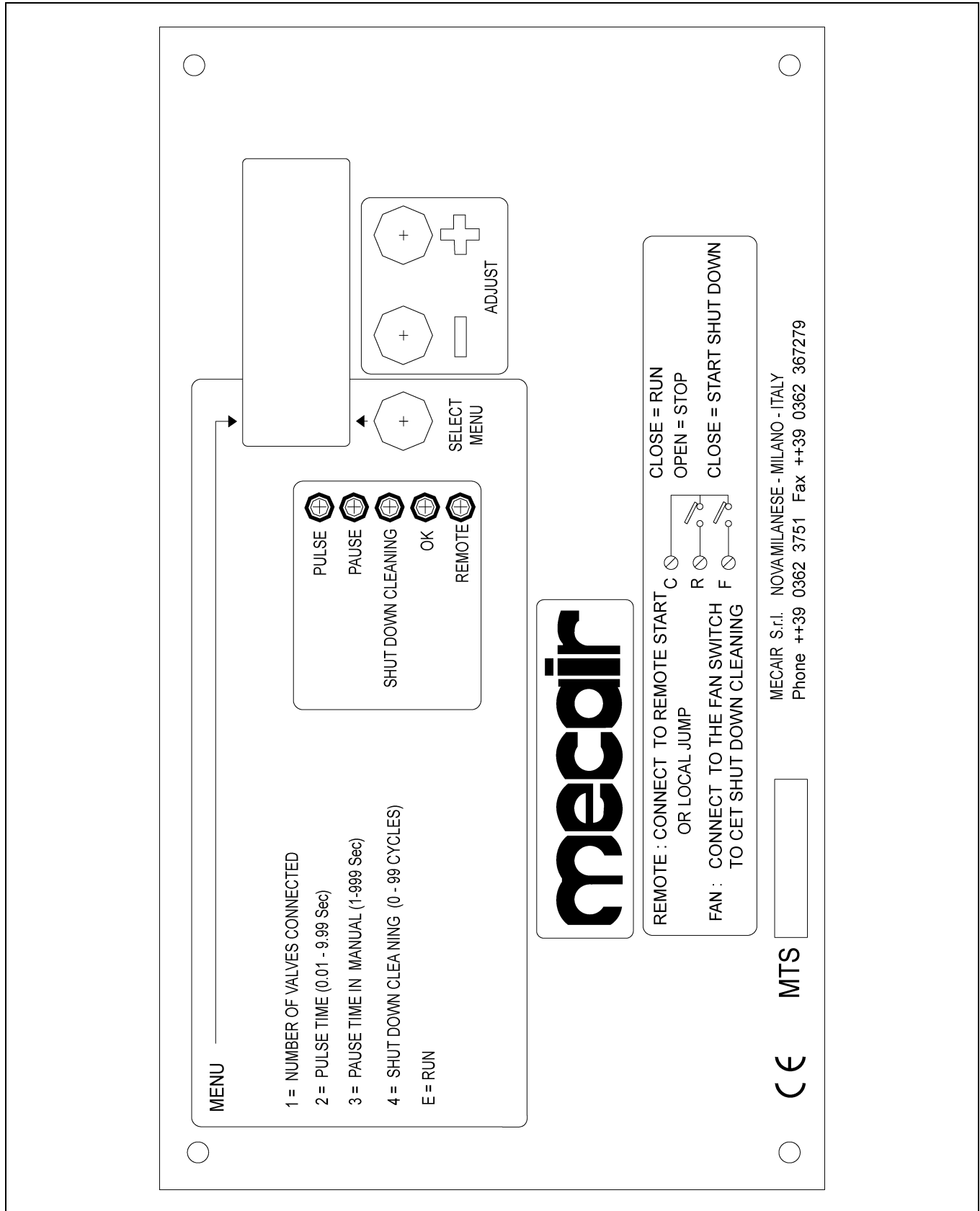

Figure 13B

InterSystems, Inc. reserves the right to make changes in design or in construction of equipment and components without obligation to incorporate such changes in equipment and components previously ordered.

WARRANTY, LIMITATION OF LIABILITY, DISCLAIMER OF IMPLIED WARRANTIES: InterSystems, Inc. manufactured equipment and components are guaranteed against defects in workmanship or materials for one year from date of shipment. The obligation of InterSystems, Inc. with respect to any goods is limited to replacement or repair of defective parts and equipment provided those parts are returned, shipping costs prepaid, to InterSystems' factory and provided the product has not been subject to misuse, negligence, or accident, or repaired or altered outside of our factory, or other than by an Authorized Service Representative. This warranty does not cover the replacement of parts inoperative because of wear occasioned by use, the cost of replacing parts by a person other than an InterSystems employee or an Authorized Service Representative, or the adjustment of a product where the product was improperly adjusted by the purchaser. In addition, this warranty does not cover components manufactured by others such as motors, drives, clutches, cylinders, valves, blowers, and the like. On those components the standard Manufacturers' warranty applies. In any event, liability is limited to the purchase price paid, and InterSystems, Inc. will, under no circumstances, be responsible for special or consequential damages, or for incidental damages.

INTERSYSTEMS, INC. NEITHER MAKES NOR AUTHORIZES ANY WARRANTY OTHER THAN AS HEREIN CONTAINED. THIS WARRANTY IS IN LIEU OF ALL OTHER WARRANTIES, EXPRESS OR IMPLIED, INCLUDING THOSE OF MERCHANTABILITY AND FITNESS FOR A PARTICULAR PURPOSE.

This equipment shall be installed in accordance with the current installation codes and applicable regulations, which should be carefully followed in all cases. Authorities having jurisdiction should be consulted before installations are made.



InterSystems
9575 N. 109th Ave.
Omaha, Nebraska 68142
Toll Free: (800) 228-1483
www.gsiag.com

