

30"-36" Bucket Elevator Platform and Ladder "X" Series

Installation Manual

PNEG-1849

Date: 02-09-12

GSI GROUP



PNEG-1849

Use of the equipment information page will help you identify the equipment in the case that you need to call your dealer or installer. This information should be filled out and kept on record.

Equipment Information

Model #: _____

Serial #: _____

Date Purchased: _____

Dealer/Distributor Name and Phone #: _____

Material Handling

1004 E. Illinois St.
Assumption, IL. 62510
Phone: 1-217-226-4421

Contents

Chapter 1 Introduction	5
Chapter 2 Safety	6
Safety Guidelines	6
Safety Instructions	7
Chapter 3 Decal Location	9
Chapter 4 Overview	10
Chapter 5 Ladder Assembly	11
Typical Ladder/Cage Setup	19
Chapter 6 Tie Angles, Ladders and Safety Cages	20
Attach Tie Angle to Boot Trunking	20
Attach Boot Ladder Support Brackets and Boot Ladder Section	21
Install Boot Ladder Section	23
Tie Angles to Trunking	25
Ladder Support Brackets	27
Attach Ladders to Ladder Brackets	29
Safety Cage Installation	30
Install Safety Cage	31
Chapter 7 Rest Platform	34
Rest Platform Tie Angles to Bucket Elevators	34
Attach Rest Platform Channel to the Rest Platform Tie Angle	36
Rest Platform Cross Channel to Rest Platform Mounting Channels	37
Ladder Support	43
Chapter 8 30"-36" Head Platform Right Hand Drive	44
Cross Deck Support Channels to Lower Head	45
For 30" Right Side Drive	46
For 36" Right Side Drive	48
Attach Deck A to Hatch Cover Plate	50
Slide/Place Toe Boards on Cross Deck Support Channels	51
Connect Deck A to Cross Deck Support Channels and Toe Board	52
Connect Deck C to Cross Deck Support Channel and to Toe Board	54
Connect Deck F to Cross Deck Support Channels and Deck C	56
Attach Third Cross Deck Support Channel to Decking	58
Attach Deck E to Deck A, Deck C and Cross Deck Support Channel	58
Chapter 9 30"-36" Head Platform Left Hand Drive	60
Attach Cross Deck Support Channels to Lower Head	61
For 30" Left Side Drive	62
For 36" Left Side Drive	64
Attach Deck A to Hatch Cover Plate	66
Slide/Place Toe Boards on Cross Deck Support Channels	67
Connect Deck A to Cross Deck Support Channels and Toe Board	68
Connect Deck C to Cross Deck Support Channel and to Toe Board	69
Connect Deck F to Cross Deck Support Channels and Deck C	71
Attach Third Cross Deck Support Channel to Decking	73
Attach Deck E to Deck A, Deck C and Cross Deck Support Channel	73

Table of Contents

Chapter 10 30"-36" Head Platform Post, Rails and Bracing	75
Attach Head Bearing Support Angle to Lower Head for 30"	75
Attach Head Bearing Support Angle to Lower Head for 36"	75
Attach Handrail Supports to Deck E	76
Install Posts	77
Install Head Side Posts	78
Attach Intermediate Handrails to Posts	81
Install Upper Handrails	83
Install Safety Cage Bar Cross Supports	85
Chapter 11 Install Hatch	86
Chapter 12 4 x 5 Distributor Platform (Optional)	89
Install Clamp Band	89
Assemble Supports	90
Assemble Decking	92
Install Handrail Posts - Non Entrance Side	94
Assemble and Install Intermediate Handrails	96
Install Safety Bar Cross Supports	96
Install Upper Handrails	97
Safety Gate Package (Optional)	98
Chapter 13 6 x 6 Distributor Platforms	99
Platform Clamps	99
Support Channels and Knee Braces	100
Toe Boards	101
Cross Braces for Knee Braces	102
Platform Decking	104
Platform Post	106
Tie Braces	107
Intermediate Handrail	108
Upper Handrails	109
Safety Gate Package (If Ordered as Optional)	112
Chapter 14 Warranty	115

Chapter 1: Introduction

READ THIS MANUAL carefully to learn how to properly use and install equipment. Failure to do so could result in personal injury or equipment damage.

INSPECT the shipment immediately upon arrival. The customer is responsible for ensuring that all quantities are correct. The customer should report and note any damage or shortage on the bill of lading to justify their claim to the transport company.

THIS MANUAL SHOULD BE CONSIDERED a permanent part of your equipment and should be easily accessible when needed.

This warranty provides you the assurance that the company will back its products when defects appear within the warranty period. In some circumstances, the company also provides field improvements, often without charge to the customer, even if the product is out of warranty. Should the equipment be abused, or modified to change its performance beyond the factory specifications, the warranty will become void and field improvements may be denied.

Chapter 2: Safety

Safety Guidelines

This manual contains information that is important for you, the owner/operator, to know and understand. This information relates to protecting **personal safety** and **preventing equipment problems**. It is the responsibility of the owner/operator to inform anyone operating or working in the area of this equipment of these safety guidelines. To help you recognize this information, we use the symbols that are defined below. Please read the manual and pay attention to these sections. Failure to read this manual and its safety instructions is a misuse of the equipment and may lead to serious injury or death.



This is the safety alert symbol. It is used to alert you to potential personal injury hazards. Obey all safety messages that follow this symbol to avoid possible injury or death.



DANGER indicates a hazardous situation which, if not avoided, will result in death or serious injury.



WARNING indicates a hazardous situation which, if not avoided, could result in death or serious injury.



CAUTION, used with the safety alert symbol, indicates a hazardous situation which, if not avoided, could result in minor or moderate injury.



NOTICE is used to address practices not related to personal injury.

Safety Instructions

Our foremost concern is your safety and the safety of others associated with this equipment. We want to keep you as a customer. This manual is to help you understand safe operating procedures and some problems that may be encountered by the operator and other personnel.

As owner and/or operator, it is your responsibility to know what requirements, hazards, and precautions exist, and to inform all personnel associated with the equipment or in the area. Safety precautions may be required from the personnel. Avoid any alterations to the equipment. Such alterations may produce a very dangerous situation where **SERIOUS INJURY** or **DEATH** may occur.

This equipment shall be installed in accordance with the current installation codes and applicable regulations, which should be carefully followed in all cases. Authorities having jurisdiction should be consulted before installations are made.

Follow Safety Instructions

Carefully read all safety messages in this manual and safety signs on your machine. Keep signs in good condition. Replace missing or damaged safety signs. Be sure new equipment components and repair parts include the current safety signs. Replacement safety signs are available from the manufacturer.

Learn how to operate the machine and how to use controls properly. Do not let anyone operate without instruction.

Keep your machinery in proper working condition. Unauthorized modifications to the machine may impair the function and/or safety and affect machine life.

If you do not understand any part of this manual or need assistance, contact your dealer.

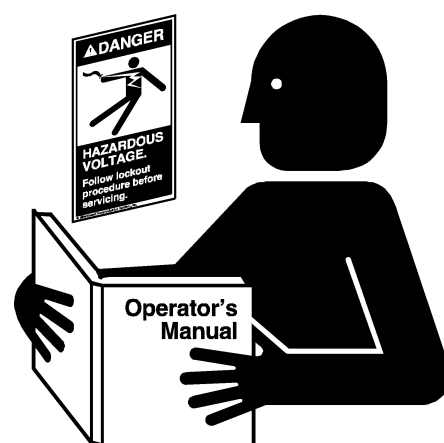

Read and Understand Manual

Practice Safe Maintenance

Understand service procedures before doing work. Keep area clean and dry.

Never lubricate, service, or adjust machine while it is in operation. Keep hands, feet, and clothing away from rotating parts.

Keep all parts in good condition and properly installed. Fix damage immediately. Replace worn or broken parts. Remove any built-up grease, oil, and debris.



Maintain Equipment and Work Area

2. Safety

Prepare for Emergencies

Be prepared if fire starts.

Keep a first aid kit and fire extinguisher handy.

Keep emergency numbers for doctors, ambulance service, hospital, and fire department near your telephone.

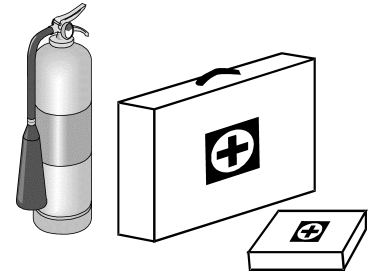

Keep Emergency Equipment Quickly Accessible

Wear Protective Clothing

Wear close-fitting clothing and safety equipment appropriate to the job.

Remove all jewelry.

Tie long hair up and back.

Wear safety glasses at all times to protect eyes from debris.

Wear gloves to protect your hands from sharp edges on plastic or steel parts.

Wear steel-toed boots to help protect your feet from falling debris. Tuck in any loose or dangling shoestrings.

A respirator may be needed to prevent breathing potentially toxic fumes and dust.

Wear a hard hat to help protect your head.

Wear appropriate fall protection equipment when working at elevations greater than six feet (6').

Eye Protection

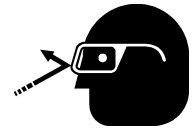

Gloves



Steel-Toed Boots



Respirator



Hard Hat



Fall Protection



Chapter 3: Decal Location

 **DANGER**



**DO NOT EXCEED
PLATFORM LOAD LIMIT**

Load limit = 500 LBS. (2.25 kN)

Excessive load will damage platform and cause platform to fall.

Injury or death will result.

DC-2146

 **WARNING**



FALL HAZARD

- Fall hazard present when hatch door open.
- Fall may result in serious injury or death
- Close hatch door while on platform.

DC-2147

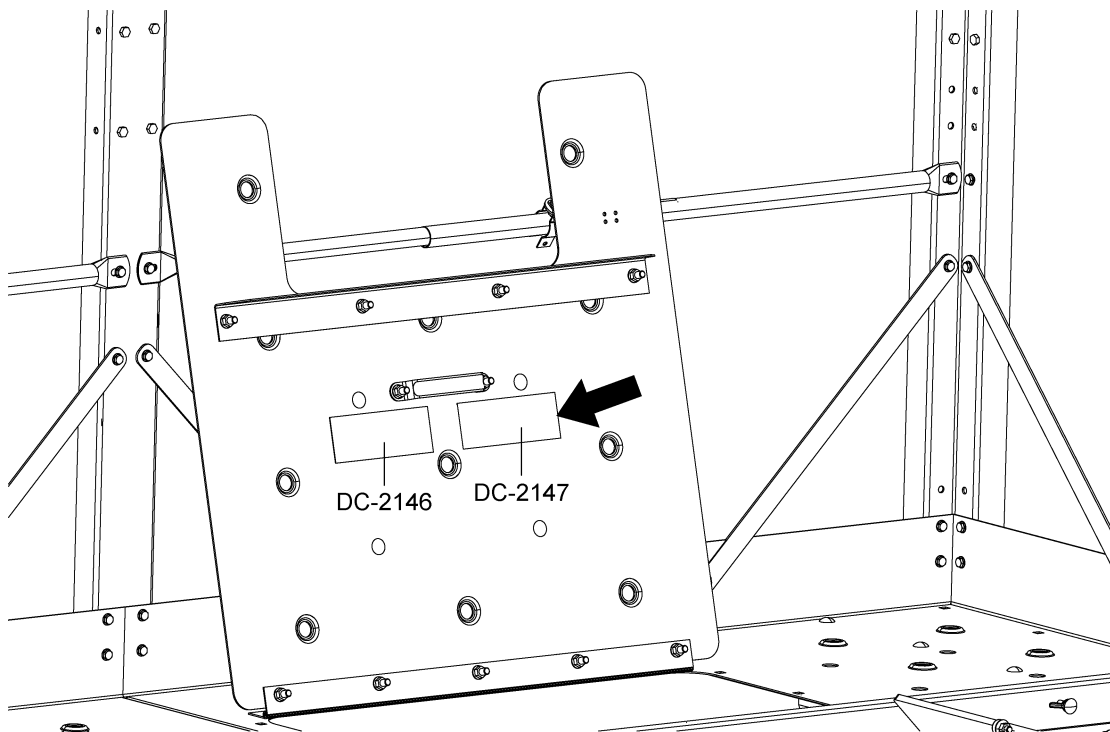

Chapter 4: Overview

This section is intended to provide a general, high-level overview of platform assembly for the GSI bucket elevator. Detailed instructions are given in the pages to come.

This section should be used for reference only and is intended to provide general guidance about the overall process only.

1. Support Channels:

Proper orientation of channels is based upon the size of the bucket elevator (16", 24", 30" or 36") and the right/left hand position of the drive. This must be installed correctly at the start or nothing else will install correctly.

2. Ladders and Safety Cages:

Ladder sections mount directly to the trunking sections of the bucket elevator. Typical ladder layouts and charts identifying the support height for ladder packages can be found [on Pages 11 through 19](#).

3. Tie Angles to Trunking:

- Proper orientation of the tie angles is critical for correct installation.
- Note differences from up-leg and down-leg installations.

Be sure to follow the instructions for the size and drive position.

Throughout this manual, particular attention is given to the initial orientation of channels and aligning bolt holes. Failure to complete these initial steps correctly will significantly impede the assembly and installation of the bucket elevator platforms.

4. Decking and Toe Boards:

Decking is etched with alpha characters to assist with orienting decks and aligning holes for connections. Decking connections should be finger-tight only initially so that adjustments can be made once all decks and toe boards are in place. Only then should all hardware be fully torqued.

5. Handrail Platform Posts:

The number and location of platform posts varies based upon platform and bucket elevator size.

6. Handrails:

Intermediate handrails (those at near knee level) may need to be field cut to fit. The amount to trim varies based upon the size of the platform being installed. The smaller rail then fits inside of the larger rail so that it "telescopes" between the posts. Always follow best practices of "measure twice, cut once" and verify the measurement is for the bucket elevator size. Upper handrails do not require any alterations in the field prior to assembly.

7. Platform Braces:

Throughout this manual, safety cage bars (LDR-517BE) are used as platform braces. These are required for support and stability. Please attach as described through the manual.

Chapter 5: Ladder Assembly

The ladder sections are to be mounted directly to the trunking sections. Quantities and section lengths may vary depending on overall height of system. If you have a non-standard height system, refer to supported bucket height reference chart *below* for the correct ladder package for the system.

Supported Bucket Height Reference Chart

Part #	Supported Bucket Height (Ft.)	Part #	Supported Bucket Height (Ft.)
1636XRLAD20	0-29	1636XWLAD20	0-29
1636XRLAD30	30-39	1636XWLAD30	30-39
1636XRLAD40	40-49	1636XWLAD40	40-49
1636XRLAD50	50-59	1636XWLAD50	50-59
1636XRLAD60	60-69	1636XWLAD60	60-69
1636XRLAD70	70-79	1636XWLAD70	70-79
1636XRLAD80	80-89	1636XWLAD80	80-89
1636XRLAD90	90-99	1636XWLAD90	90-99
1636XRLAD100	100-109	1636XWLAD100	100-109
1636XRLAD110	110-119	1636XWLAD110	110-119
1636XRLAD120	120-129	1636XWLAD120	120-129
1636XRLAD130	130-139	1636XWLAD130	130-139
1636XRLAD140	140-149	1636XWLAD140	140-149
1636XRLAD150	150-159	1636XWLAD150	150-159
1636XRLAD160	160-169	1636XWLAD160	160-169
1636XRLAD170	170-179	1636XWLAD170	170-179
1636XRLAD180	180-189	1636XWLAD180	180-189
1636XRLAD190	190-199	1636XWLAD190	190-199
1636XRLAD200	200-209	1636XWLAD200	200-209

NOTE: Ladders are of a modular design for ease of modification in the field. These illustrations are only to be used as a “general” guide to installation layout. The exact assembly may vary due to the unique nature of each bucket elevator.

See [Figures 5A-5G on Pages 12-18](#) to help determine if the ladders should be started on the up-leg or down-leg of the elevator and also aid in the ladder order and rest platform locations for bucket elevators with heights from 20' through 180'.



Due to O.H.S.A. standards, it is required that a rest platform be installed every 30'.

5. Ladder Assembly

Key: HP = Head Platform
 RP = Rest Platform

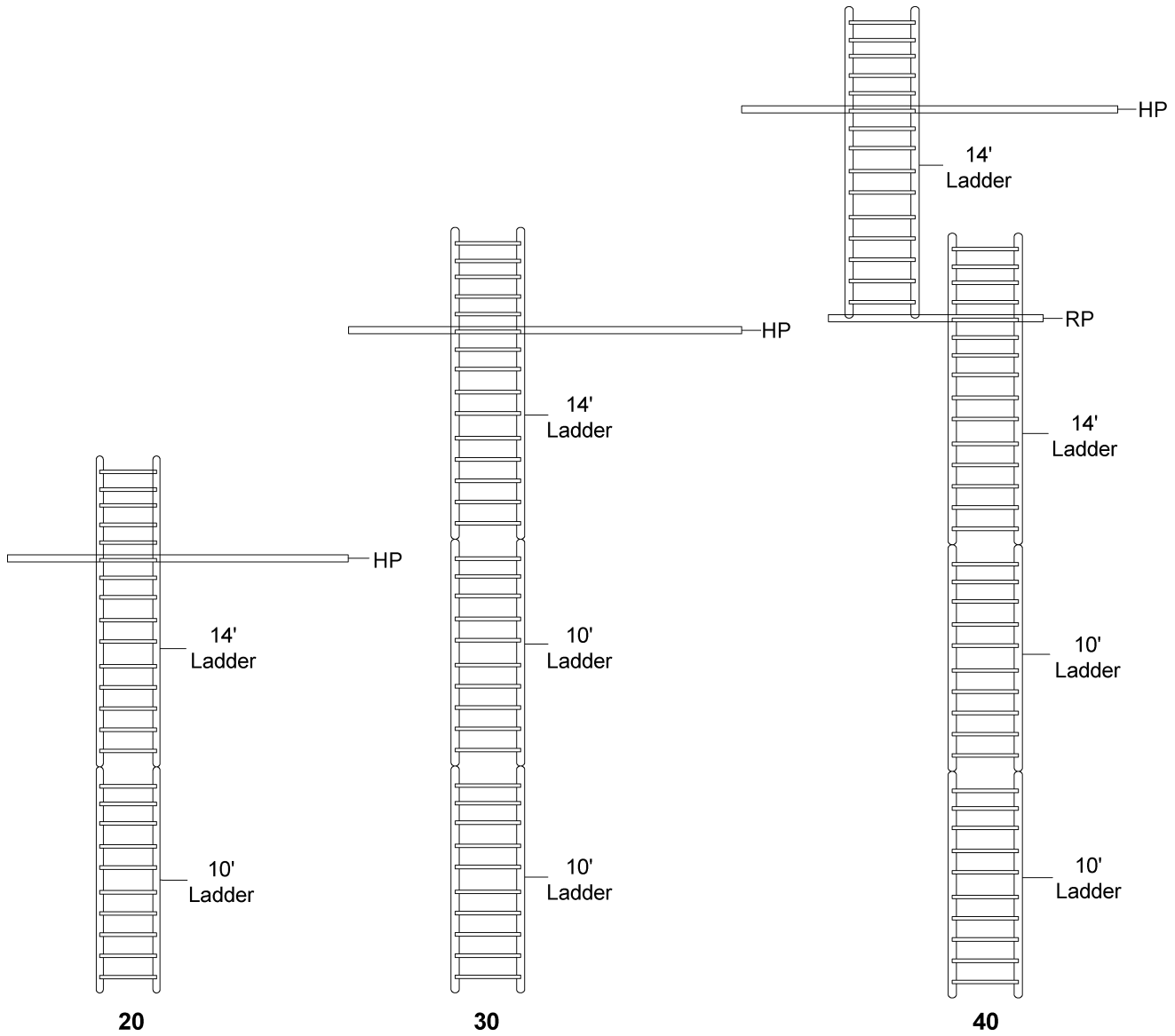

20' Bucket elevator
 (1636XRLAD20)
 (1636XWLAD20)

30' Bucket elevator
 (1636XRLAD30)
 (1636XWLAD30)

40' Bucket elevator
 (1636XRLAD40)
 (1636XWLAD40)

Figure 5A

Key: HP = Head Platform
RP = Rest Platform

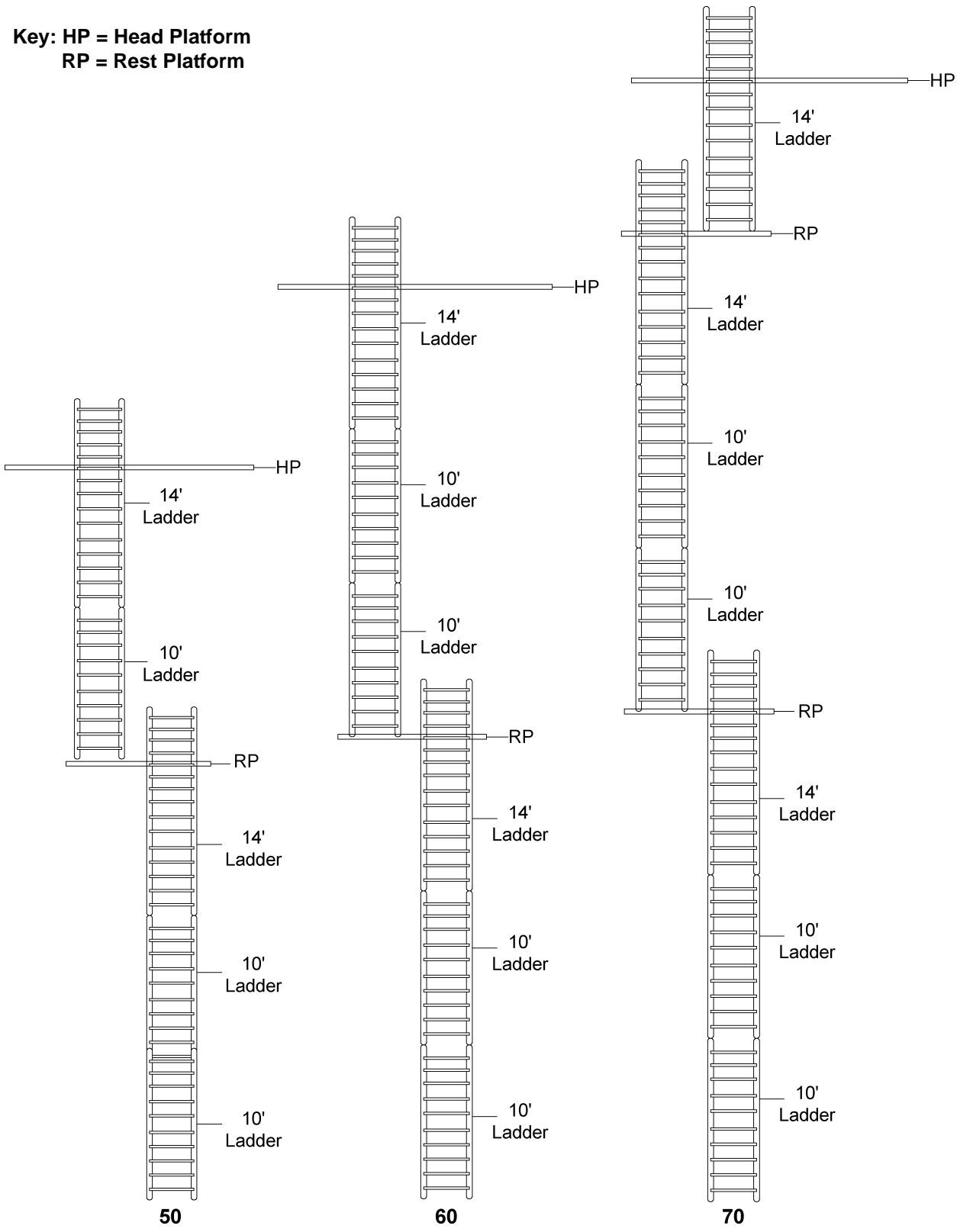

50' Bucket elevator
(1636XRLAD50)
(1636XWLAD50)

60' Bucket elevator
(1636XRLAD60)
(1636XWLAD60)

70' Bucket elevator
(1636XRLAD70)
(1636XWLAD70)

Figure 5B

5. Ladder Assembly

Key: HP = Head platform
RP = Rest platform

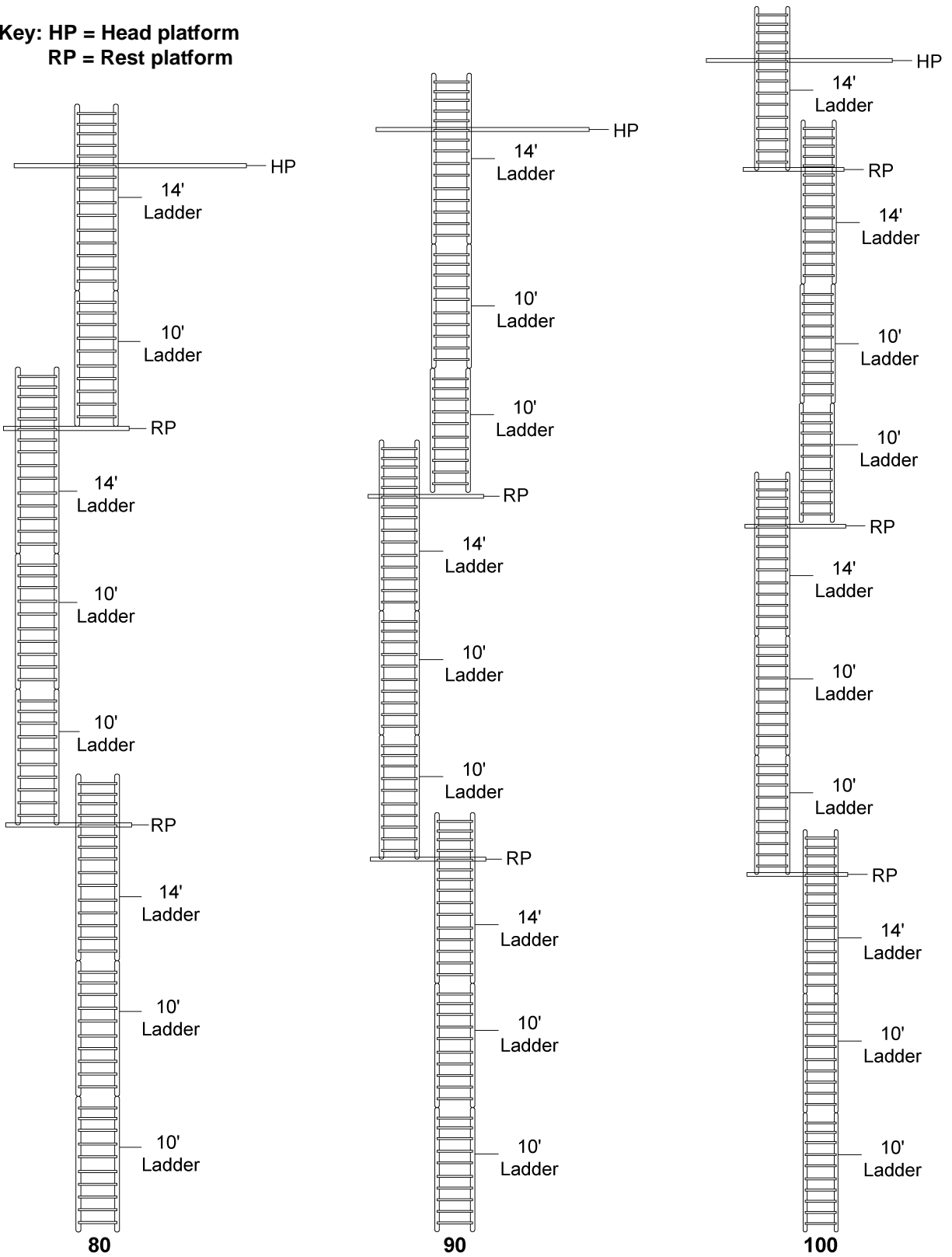

**80' Bucket elevator
(1636XRLAD80)
(1636XWLAD80)**

**90' Bucket elevator
(1636XRLAD90)
(1636XWLAD90)**

**100' Bucket elevator
(1636XRLAD100)
(1636XWLAD100)**

Figure 5C

Key: HP = Head Platform
RP = Rest Platform

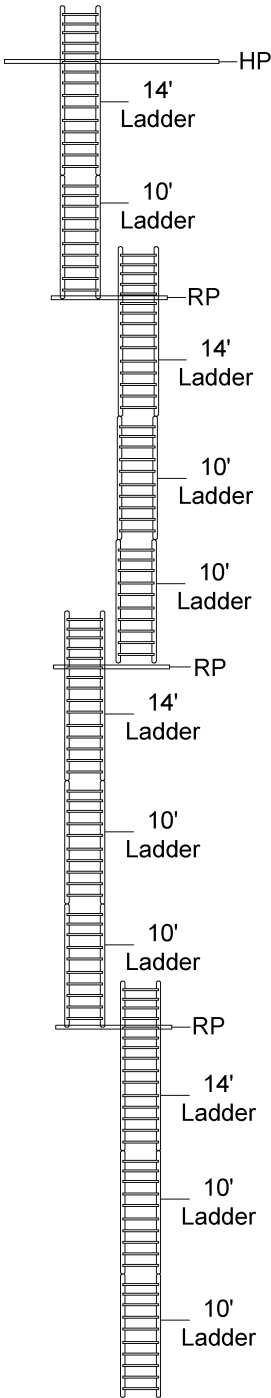

110
110' Bucket elevator
(1636XRLAD110)
(1636WRLAD110)

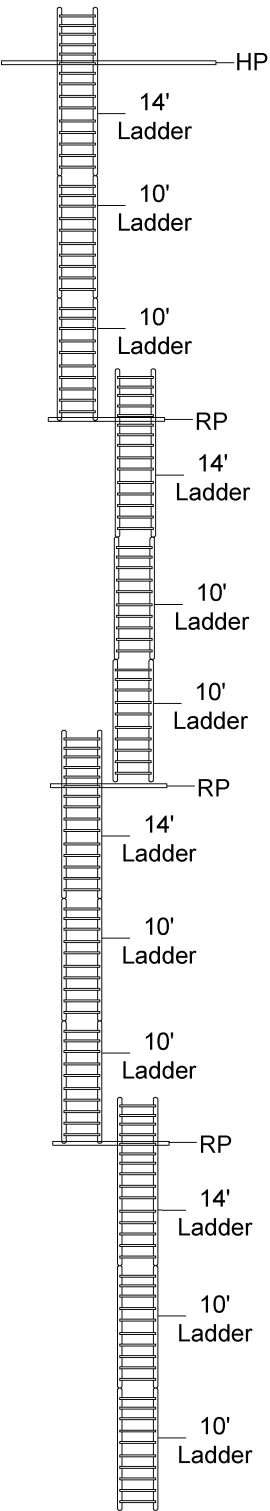

120
120' Bucket elevator
(1636XRLAD120)
(1636XWLAD120)

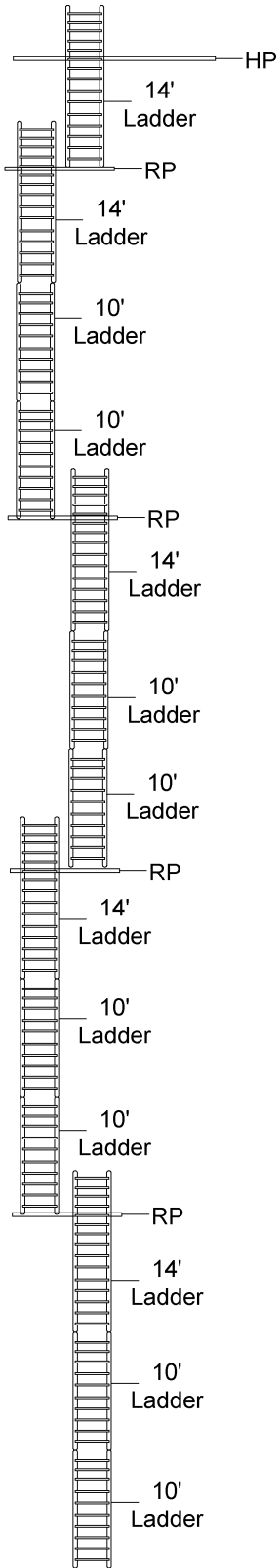

130
130' Bucket elevator
(1636XRLAD130)
(1636XWLAD130)

Figure 5D

5. Ladder Assembly

Key: HP = Head Platform
RP = Rest Platform

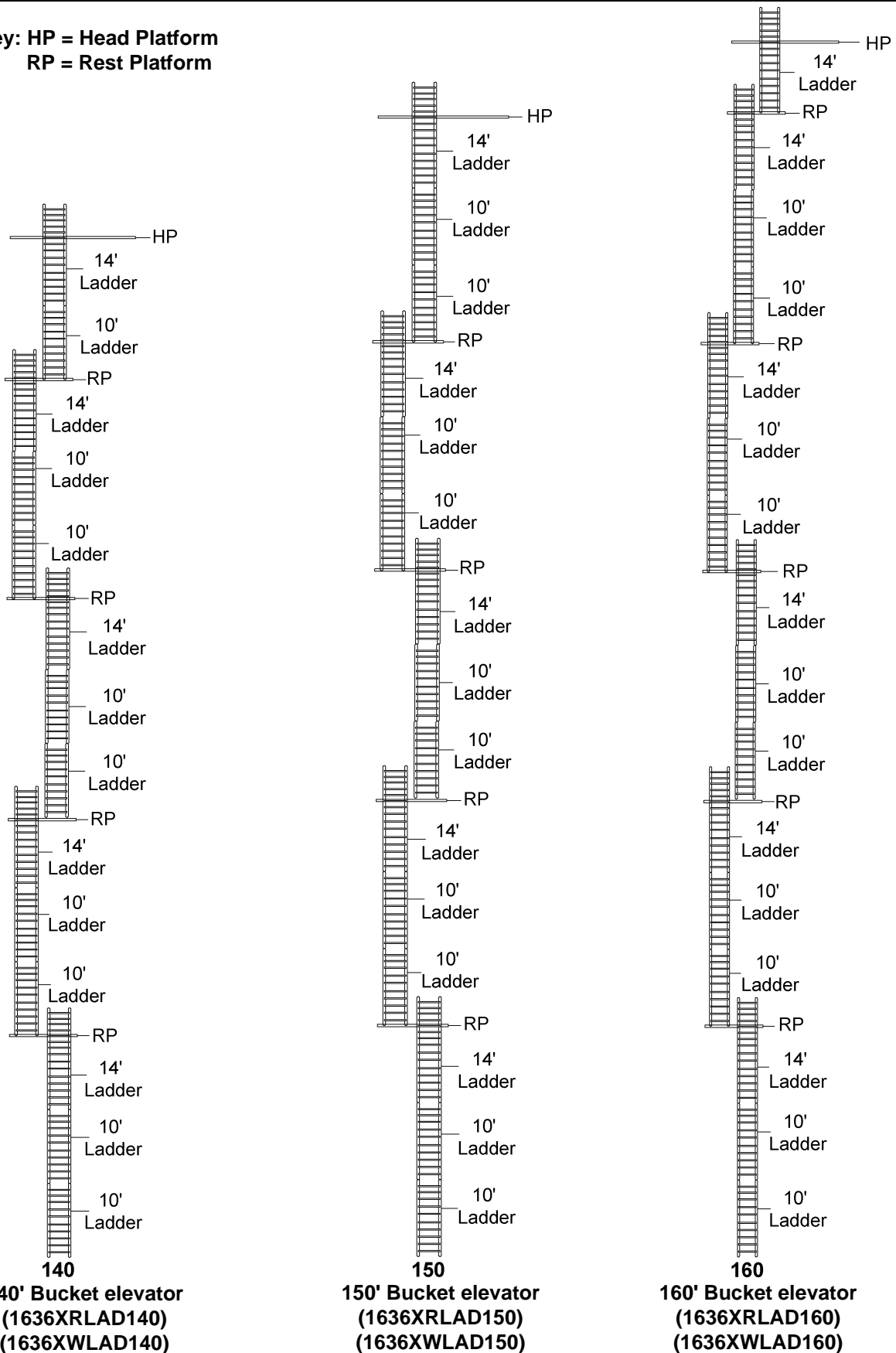
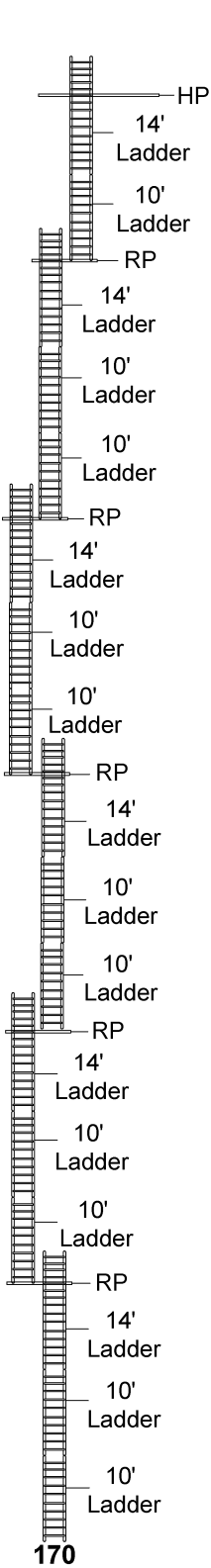
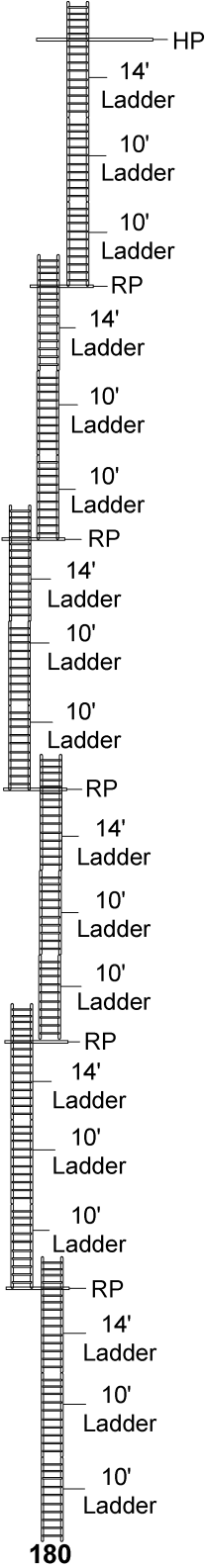

Figure 5E

Key: HP = Head Platform
RP = Rest Platform



**170' Bucket elevator
(1636XRLAD170)
(1636XWLAD170)**



**180' Bucket elevator
(1636XRLAD180)
(1636XWLAD180)**

Figure 5F

5. Ladder Assembly

**Key: HP = Head Platform
RP = Rest Platform**

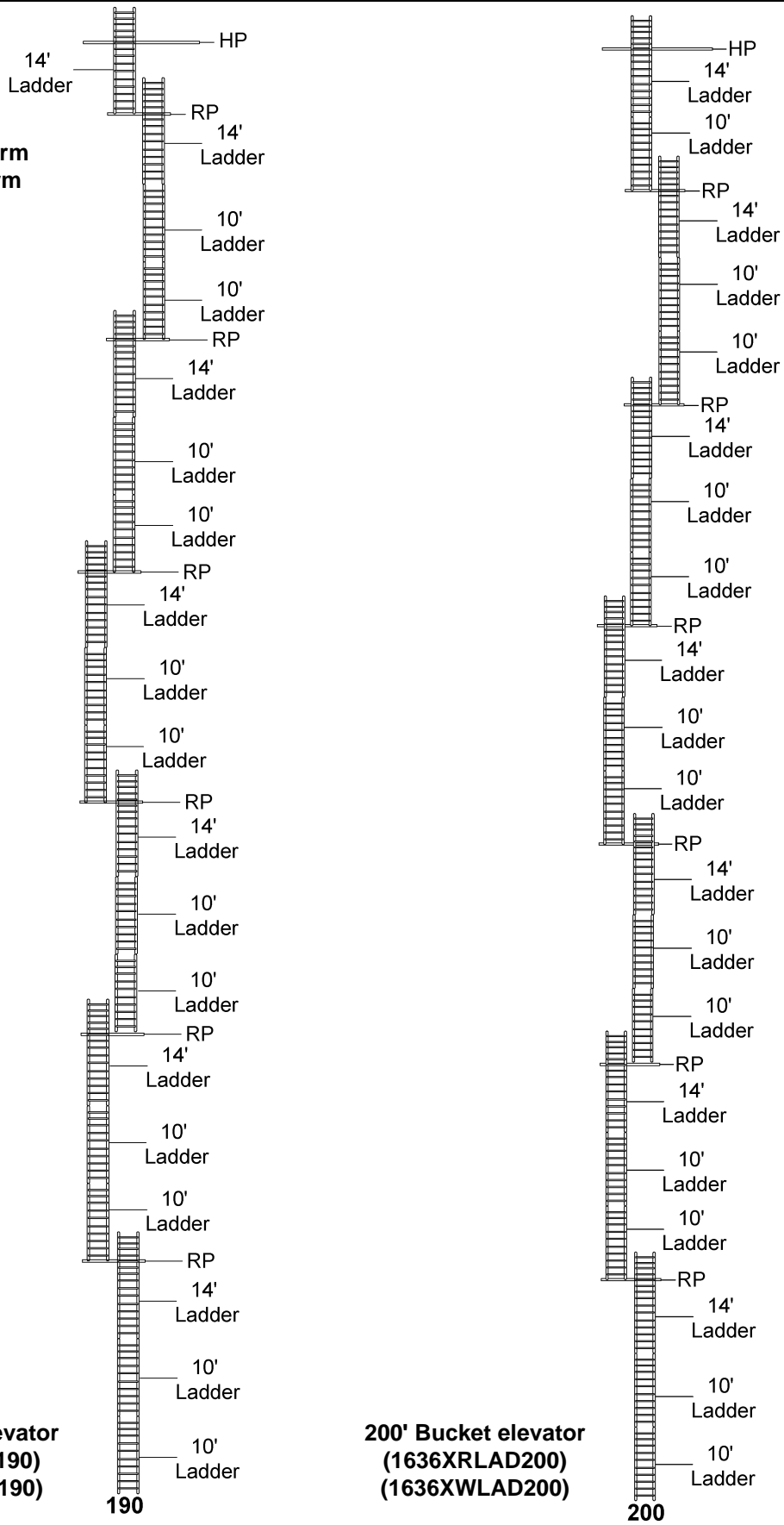

**190' Bucket elevator
(1636XRLAD190)
(1636XWLAD190)**

**200' Bucket elevator
(1636XRLAD200)
(1636XWLAD200)**

Figure 5G

Typical Ladder/Cage Setup

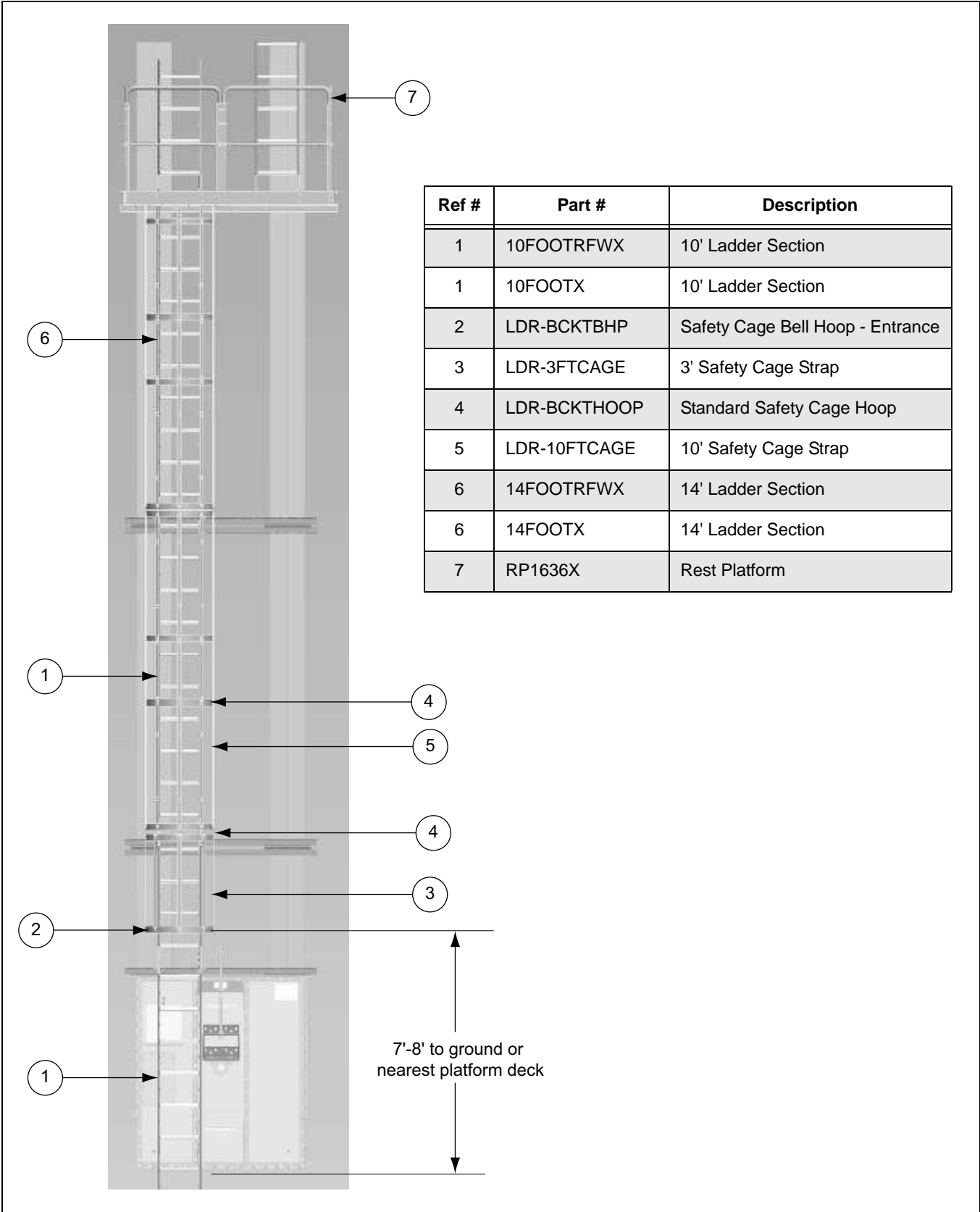

Figure 5H Typical Ladder/Cage Assembly Layout (30' Shown.)

Chapter 6: Tie Angles, Ladders and Safety Cages

Attach Tie Angle to Boot Trunking

1. On the NON LADDER SIDE, attach tie angle to the trunking using 1/2" x 1" bolts. (See Figure 6A and Figure 6B.)
 - a. **For 30" Boot Tie Angle:** With lip of tie angle up and outward, align tie angle so that it extends beyond the trunking at each end. (See Figure 6A.).

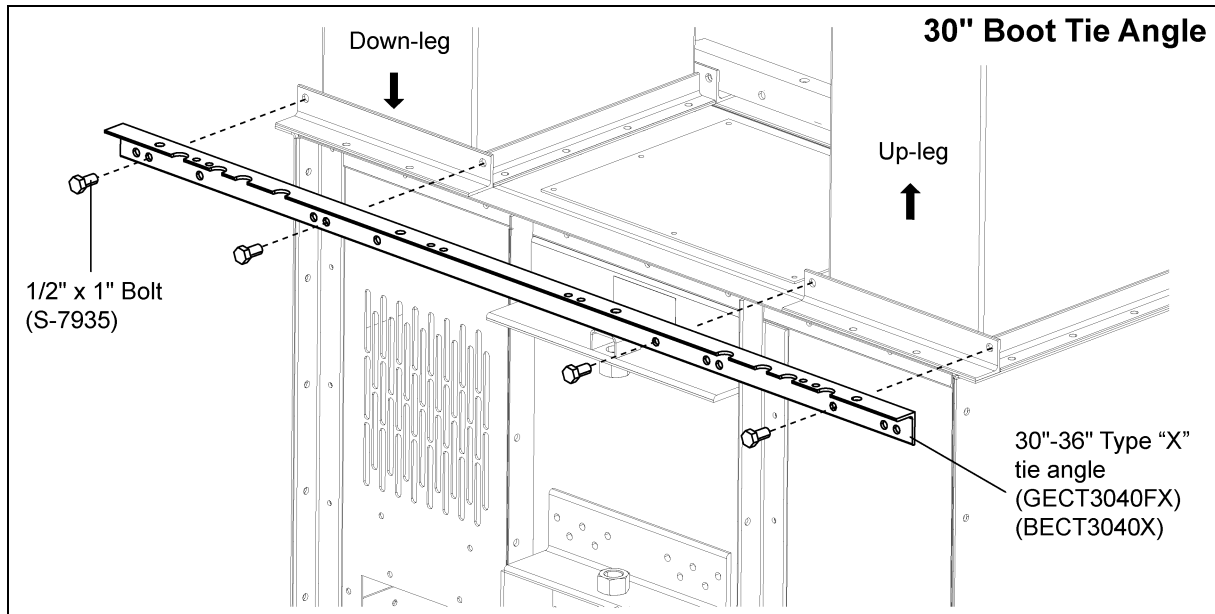

Figure 6A 30" Boot Tie Angle

- b. **For 36" Boot Tie Angle:** With lip of tie angle up and outward, align both edges of tie angle to edges of trunking. Note the tie angle will not extend beyond the trunking. (See Figure 6B.)

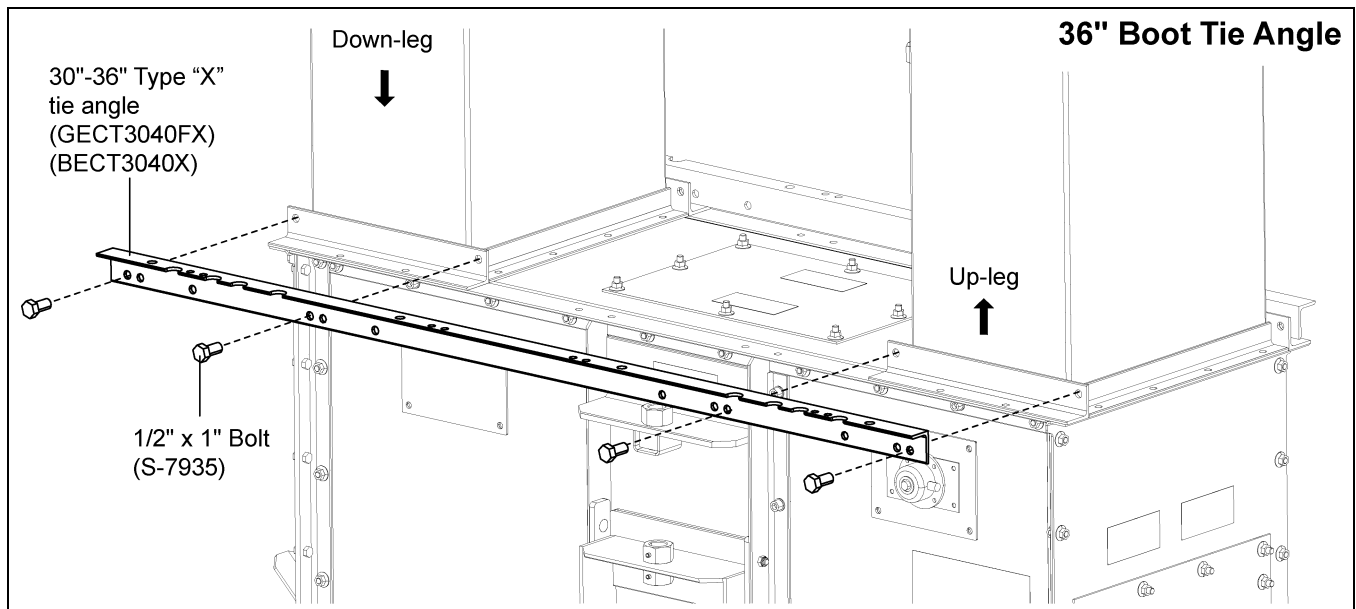

Figure 6B 36" Boot Tie Angle

Attach Boot Ladder Support Brackets and Boot Ladder Section

NOTE: Refer to ladder layout images, [Figure 5A-5G on Pages 12-18](#).

NOTE: Ladders can be mounted to either the up-leg or down-leg end of the elevator depending on the height and head platform hatch location.

NOTE: Both up-leg and down-leg bracket locations are shown in this manual, however, only one will actually be installed based on owner preference and layout of the elevator.

Depending on the height and head platform hatch location. Ladder can be mounted to either the up-leg or the down-leg side, refer to ladder layout [Figure 5A-5G on Pages 12-18](#). **NOTE:** Both up-leg and down-leg bracket locations are shown, but only one side will be used.

1. Use the holes indicated based on bucket elevator size in [Figure 6C](#) and attach ladder support brackets to boot tie angle using 3/8" x 1" hex bolts. Remember to double check if the ladder should start on the up-leg side or the down-leg side. ([See Figure 6C below and Figure 6D on Page 22.](#))
 - a. **30"-36" Down-Leg Bracket:** Use 3/8" x 1" hex bolts to attach the ladder support brackets to the boot tie angle using the holes indicated in [Figure 6C](#). Note the outer bracket uses the first set of holes on the outside.

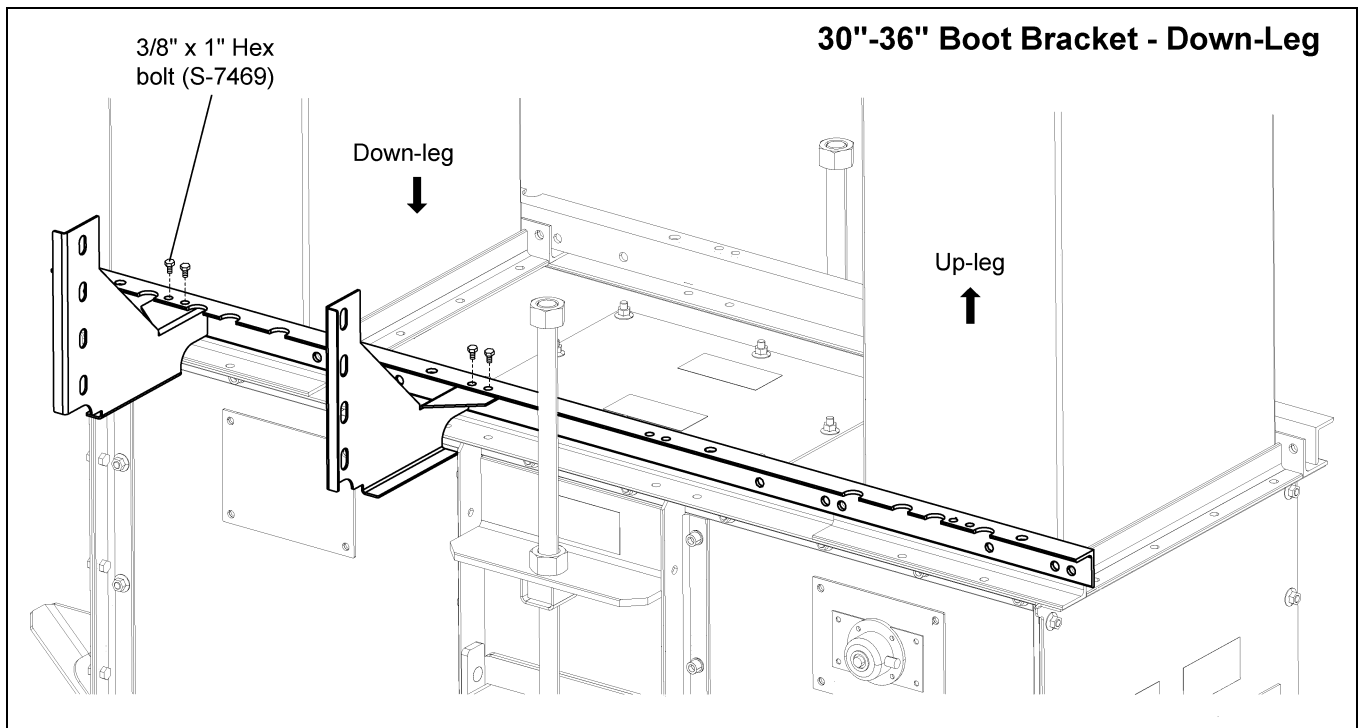

Figure 6C 30"-36" Boot Bracket Down-Leg

6. Tie Angles, Ladders and Safety Cages

- b. **30"-36" Up-Leg Bracket:** Use 3/8" x 1" hex bolts to attach the ladder support brackets to the boot tie angle using the holes indicated in *Figure 6D*. Note the outer bracket uses the first set of holes towards the outside.

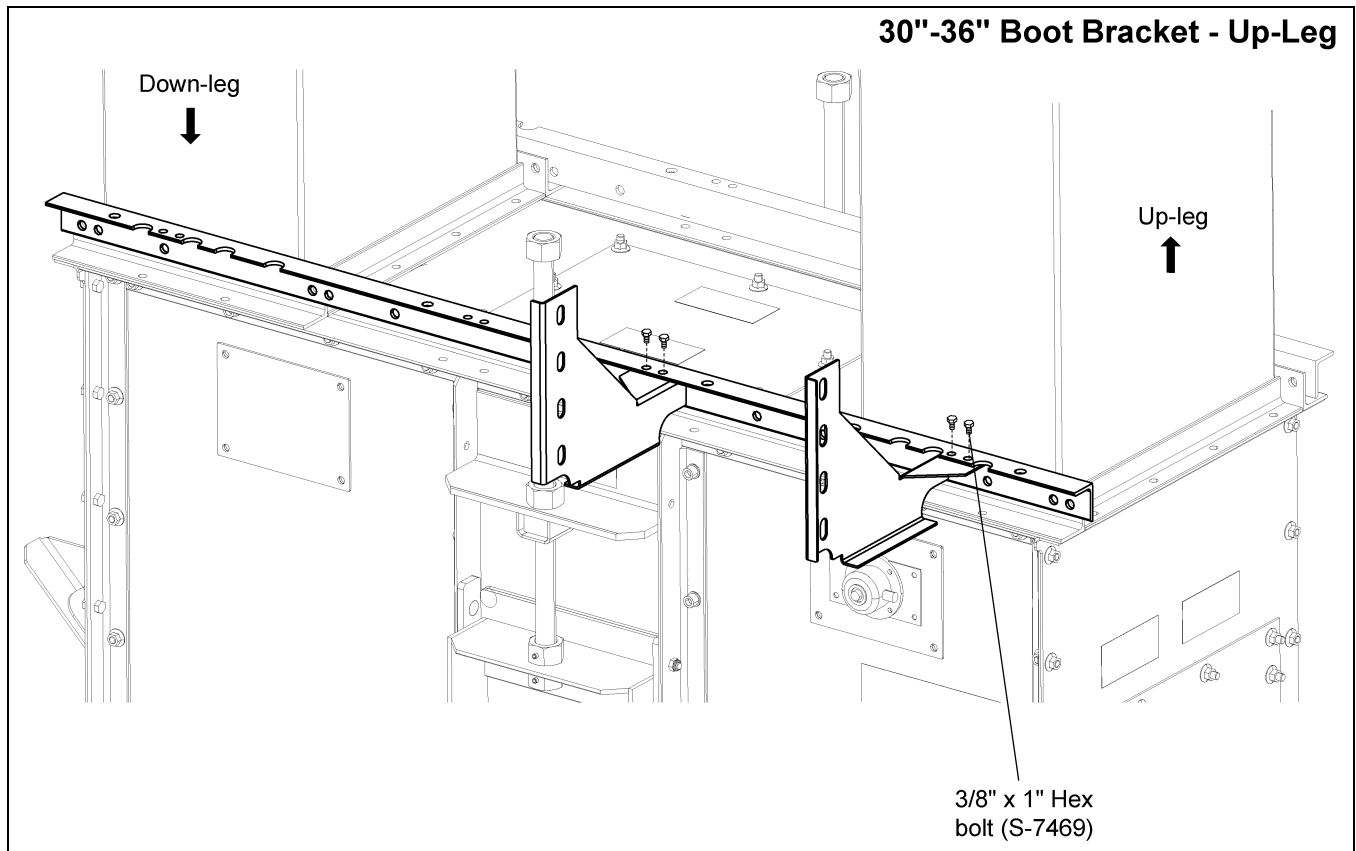

Figure 6D 30\"-36\" Boot Bracket Up-Leg

Install Boot Ladder Section

1. Trim a 10' ladder section to sit so that the first ladder rung is 12" from the ground. (See Figure 6E.)

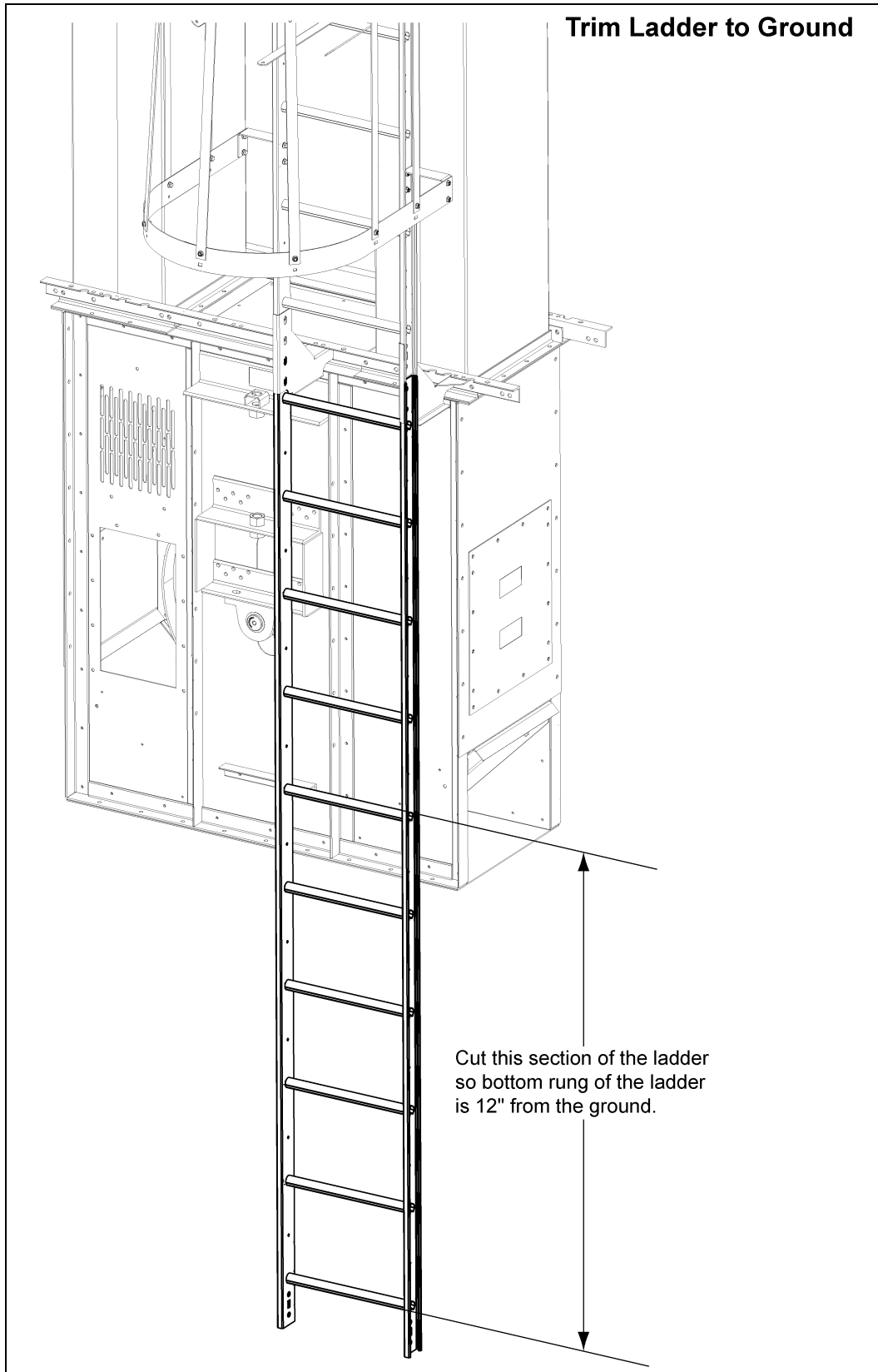

Figure 6E

6. Tie Angles, Ladders and Safety Cages

2. Attach trimmed ladder section to the left and right ladder brackets using 1/2" x 1" hex bolts through the bottom most set of holes.
3. Attach the next ladder section to the ladder brackets using 1/2" x 1" hex bolts through the top set of holes. (See Figure 6F.)

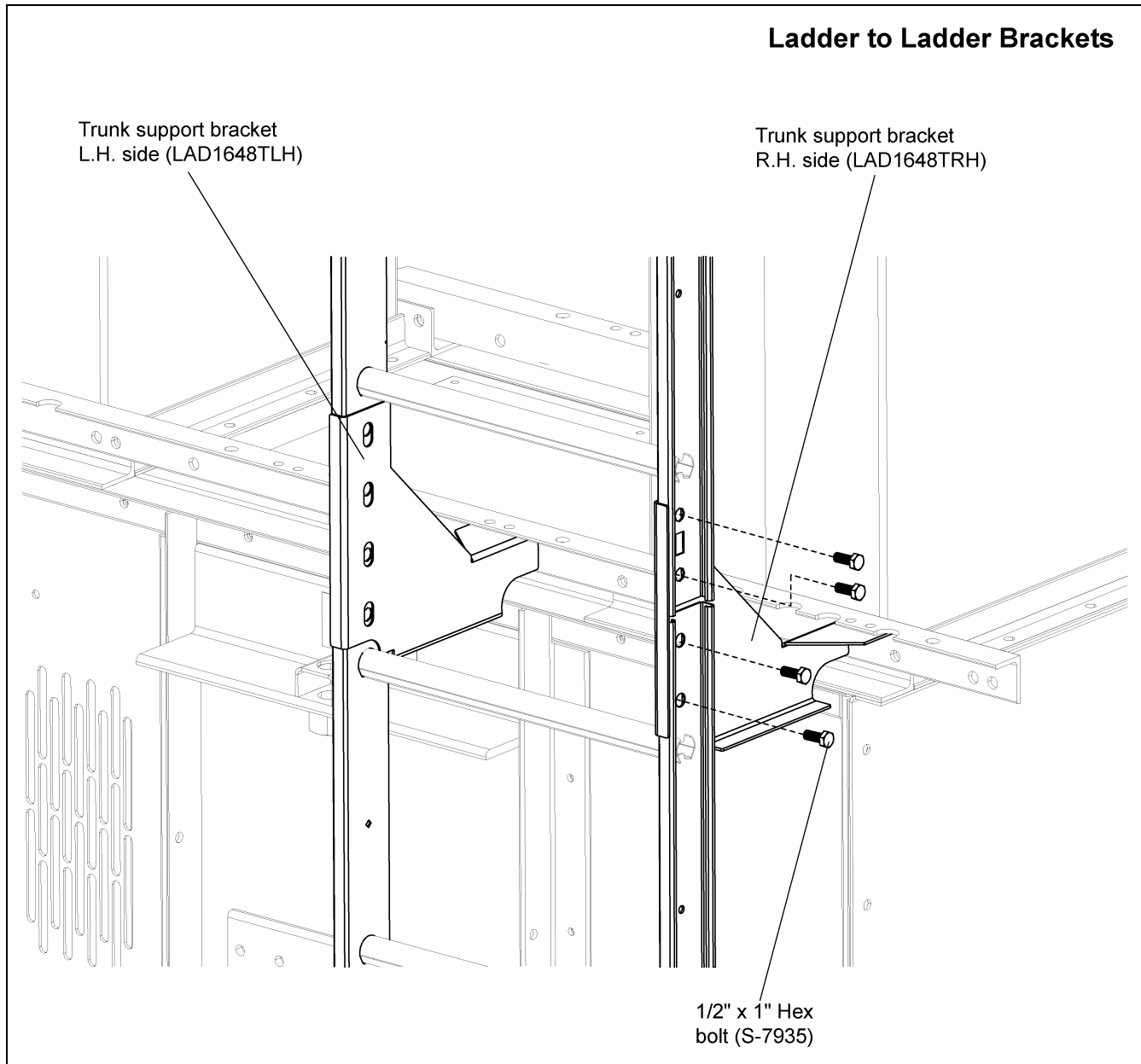

Figure 6F

4. Secure the bottom of the ladder to the boot or ground. **NOTE:** Bracket for this step is not included.

Tie Angles to Trunking

1. Tie angles must be mounted to each trunking seam on both the ladder and non-ladder side of the trunking. Use 1/2" x 1" bolts. *See Figures 6G-6I on Pages 25 and 26* for the correct location of bolts for each elevator size.

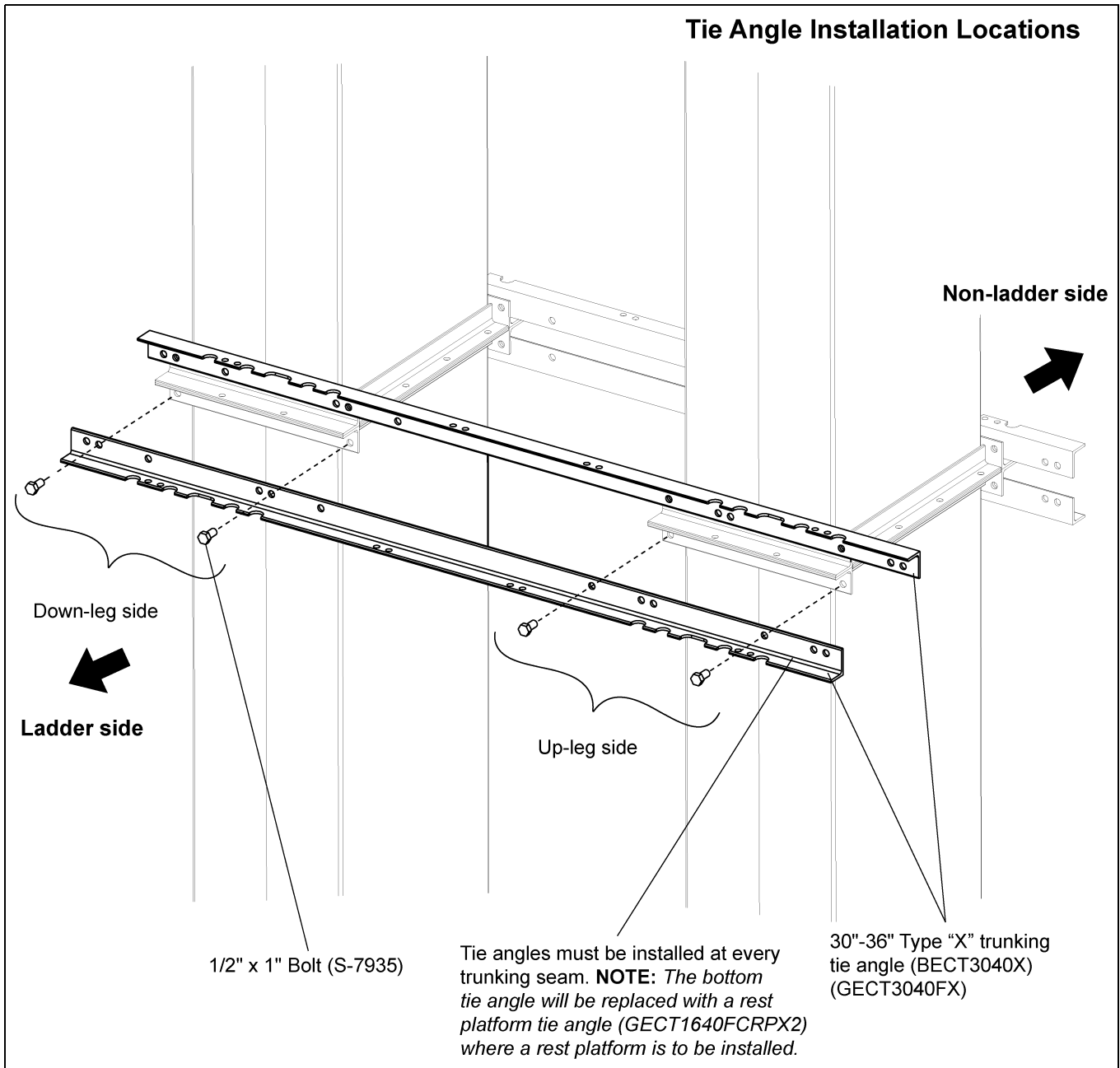

Figure 6G Tie Angle Installation Location

6. Tie Angles, Ladders and Safety Cages

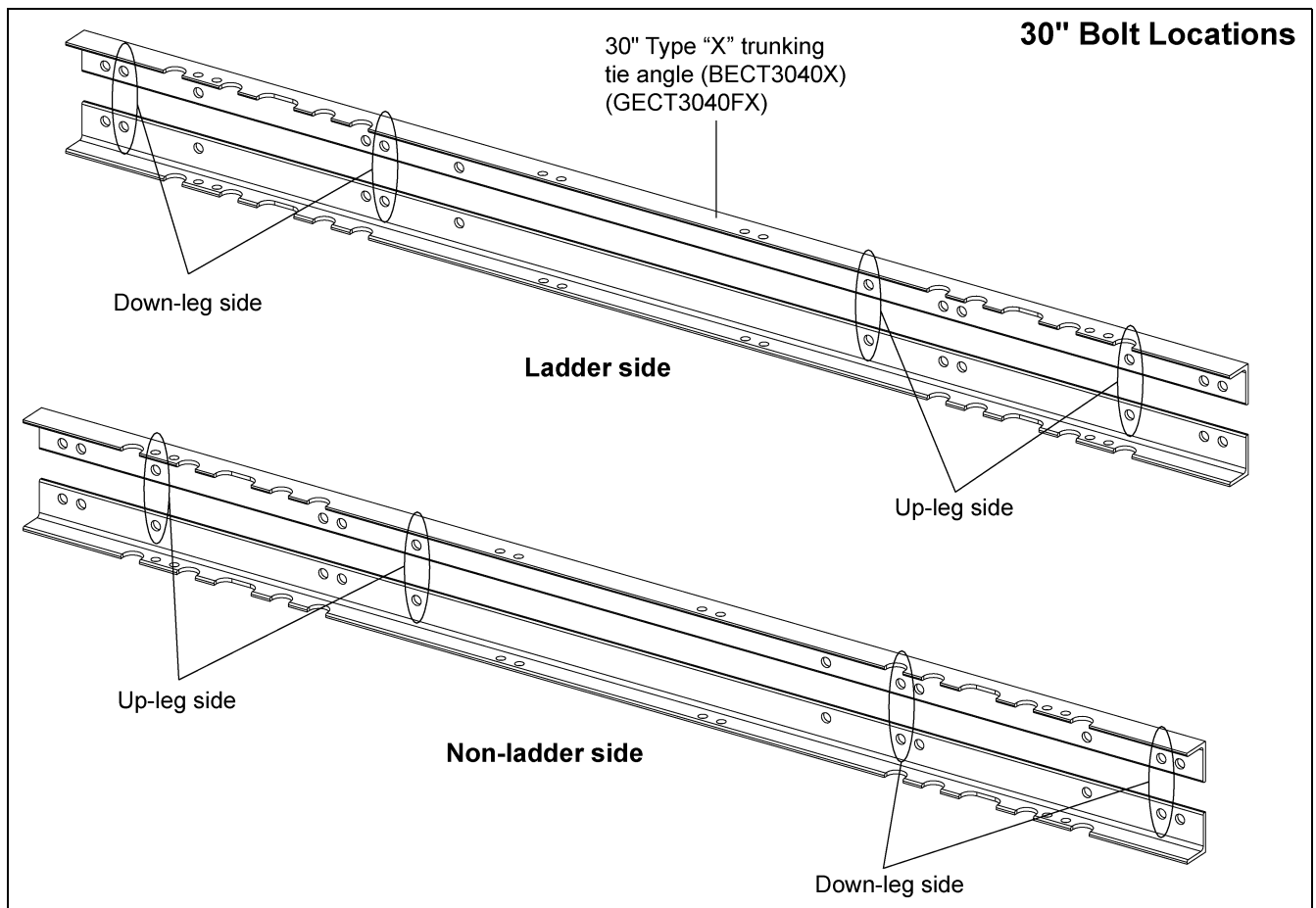

Figure 6H 30" Bucket Elevator Tie Angles to Trunking Bolt Locations

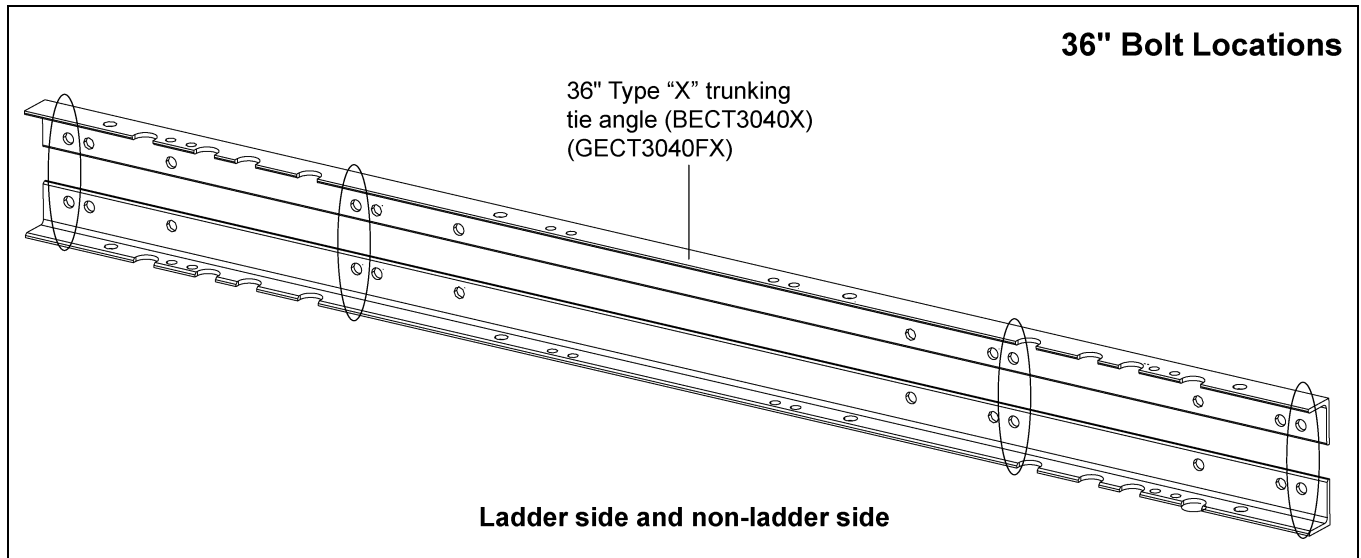

Figure 6I 36" Bucket Elevator Tie Angles to Trunking Bolt Locations

Ladder Support Brackets

1. Attach ladder support brackets to tie angle using 3/8" x 1" hex bolts (S-7469). Use the holes shown in [Figure 6J](#) for each size elevator.
2. Mount the upper right and upper left hand ladder support brackets to the top tie angle with 3/8" bolts.
3. Mount the lower right hand and lower left hand ladder support brackets to the bottom tie angle with 3/8" bolts. ([See Figure 6J.](#))
4. Secure the flanges of the ladder brackets together with 3/8" x 1" hex bolts.

NOTE: You will only use one set of ladder brackets, either the up-leg set or the down-leg set.

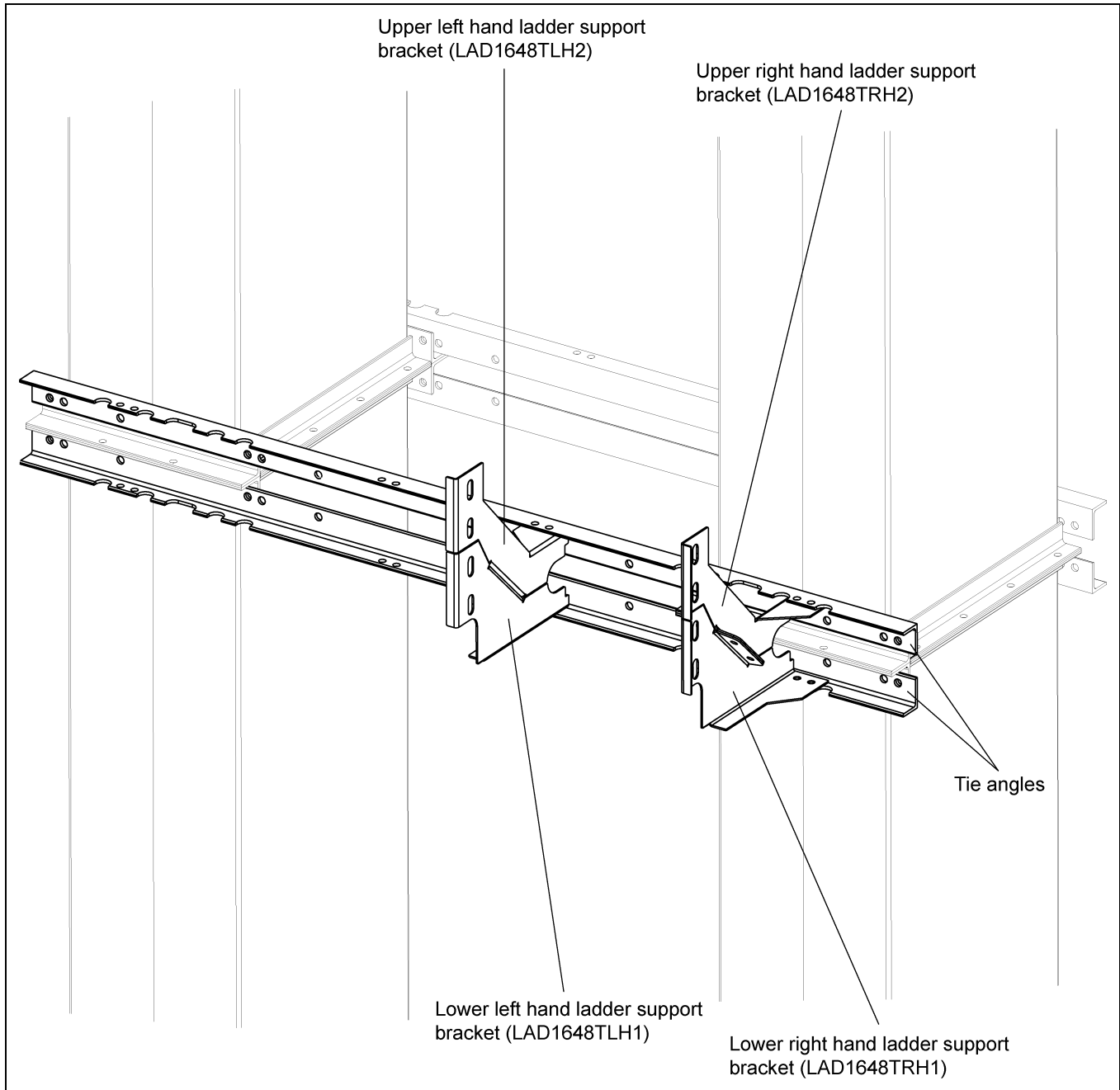

Figure 6J Ladder Support Bracket Parts

6. Tie Angles, Ladders and Safety Cages

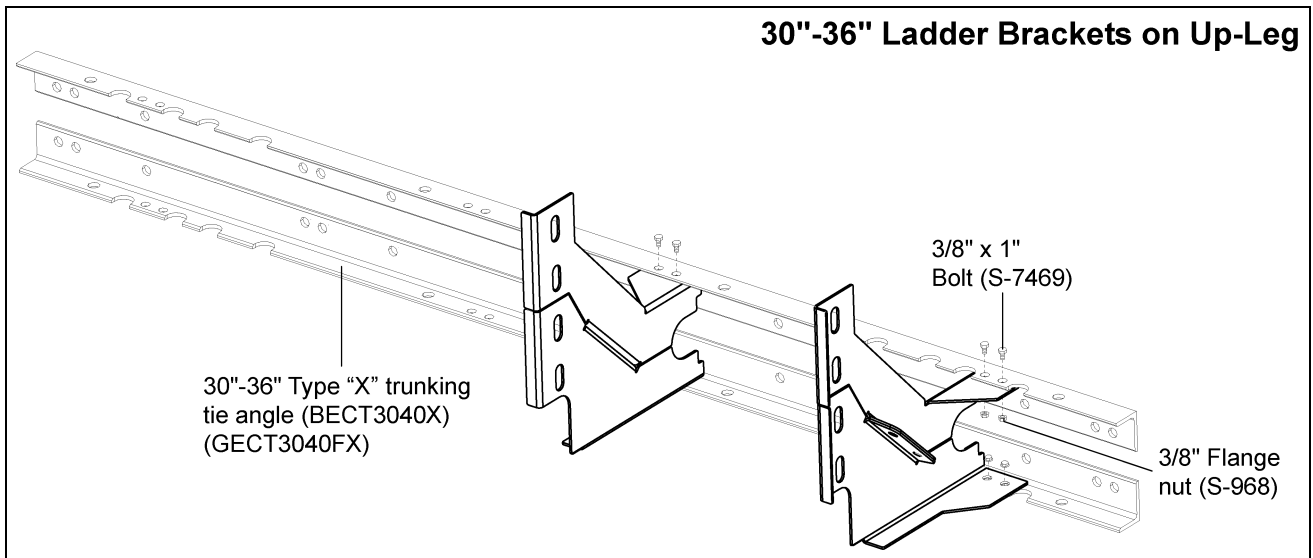

Figure 6K 30"-36" Ladder Bracket Location for Up-Leg

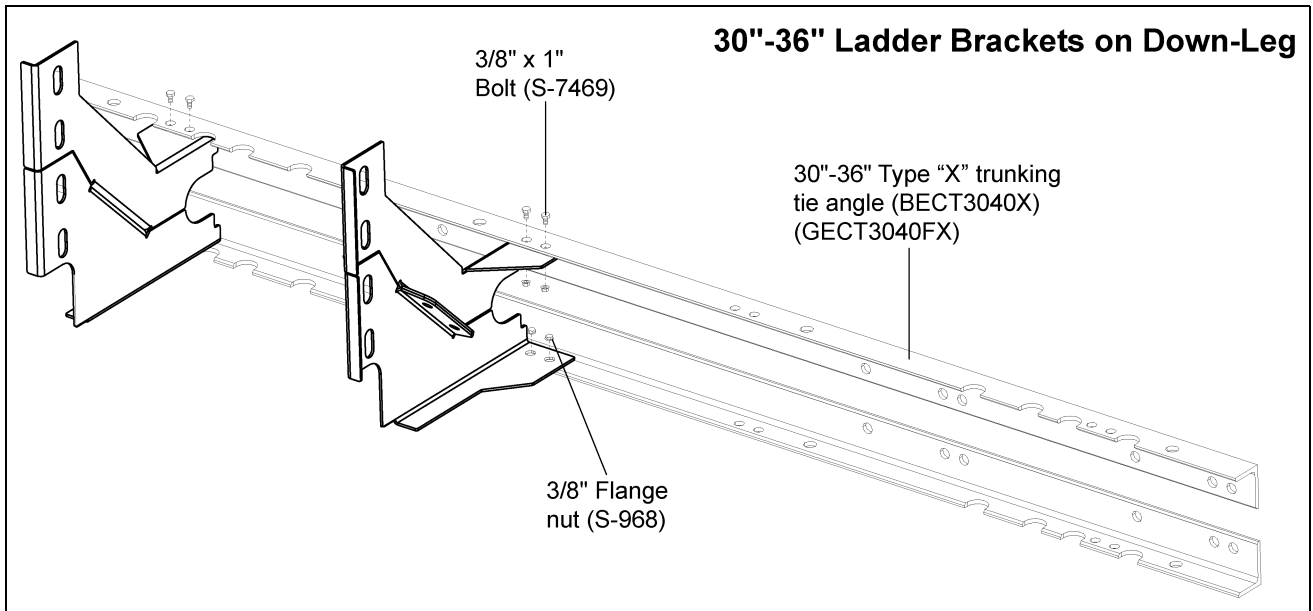

Figure 6L 30"-36" Ladder Bracket Location for Down-Leg

Attach Ladders to Ladder Brackets

1. Attach ladder sections to the ladder brackets using 1/2" x 1" hex bolts (S-7935). (See Figure 6M.)

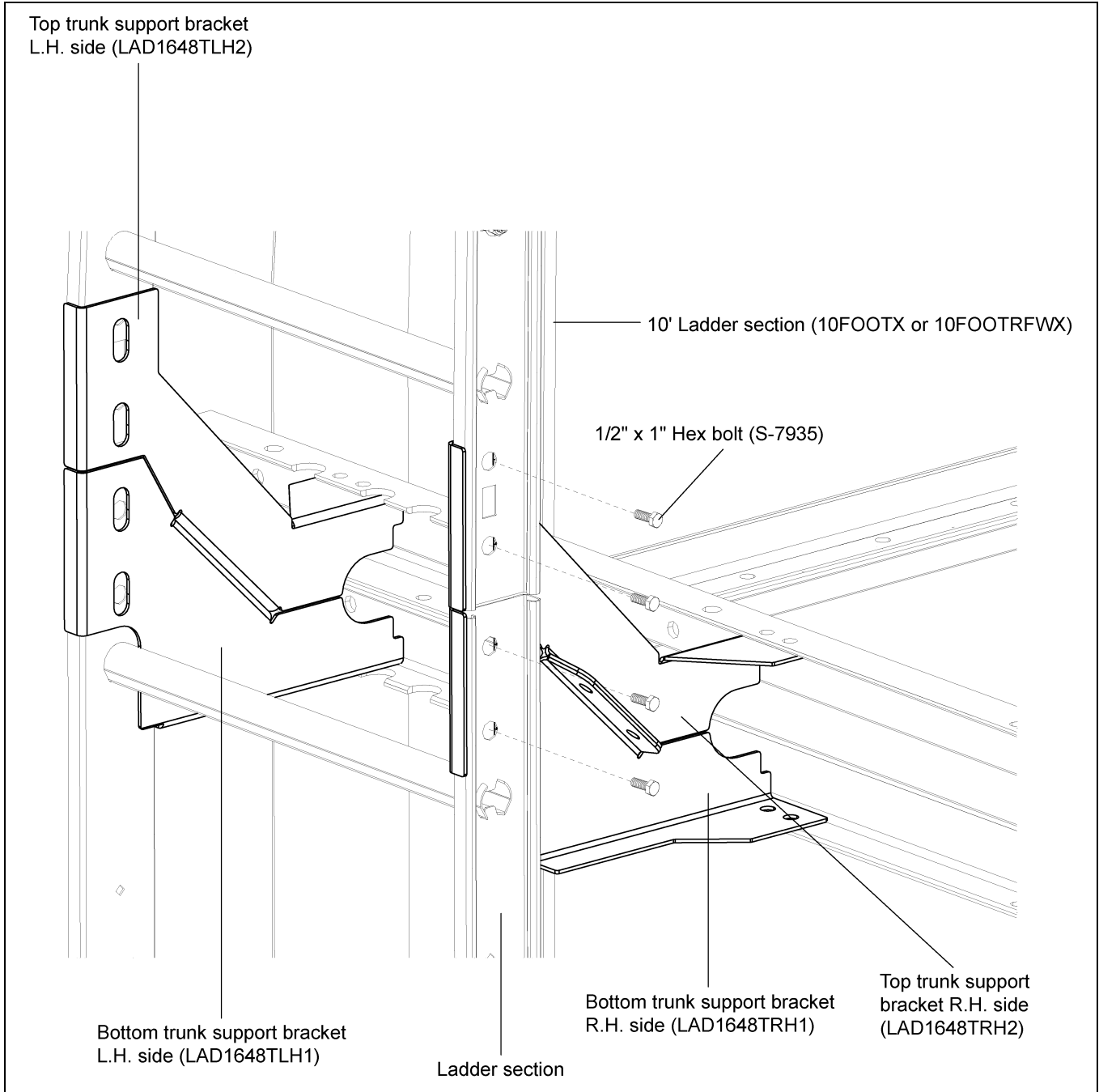

Figure 6M

Safety Cage Installation

Safety cage entrance must be installed to the ladders within 7'-8' from the ground or platform deck.
(See Figure 6N.)

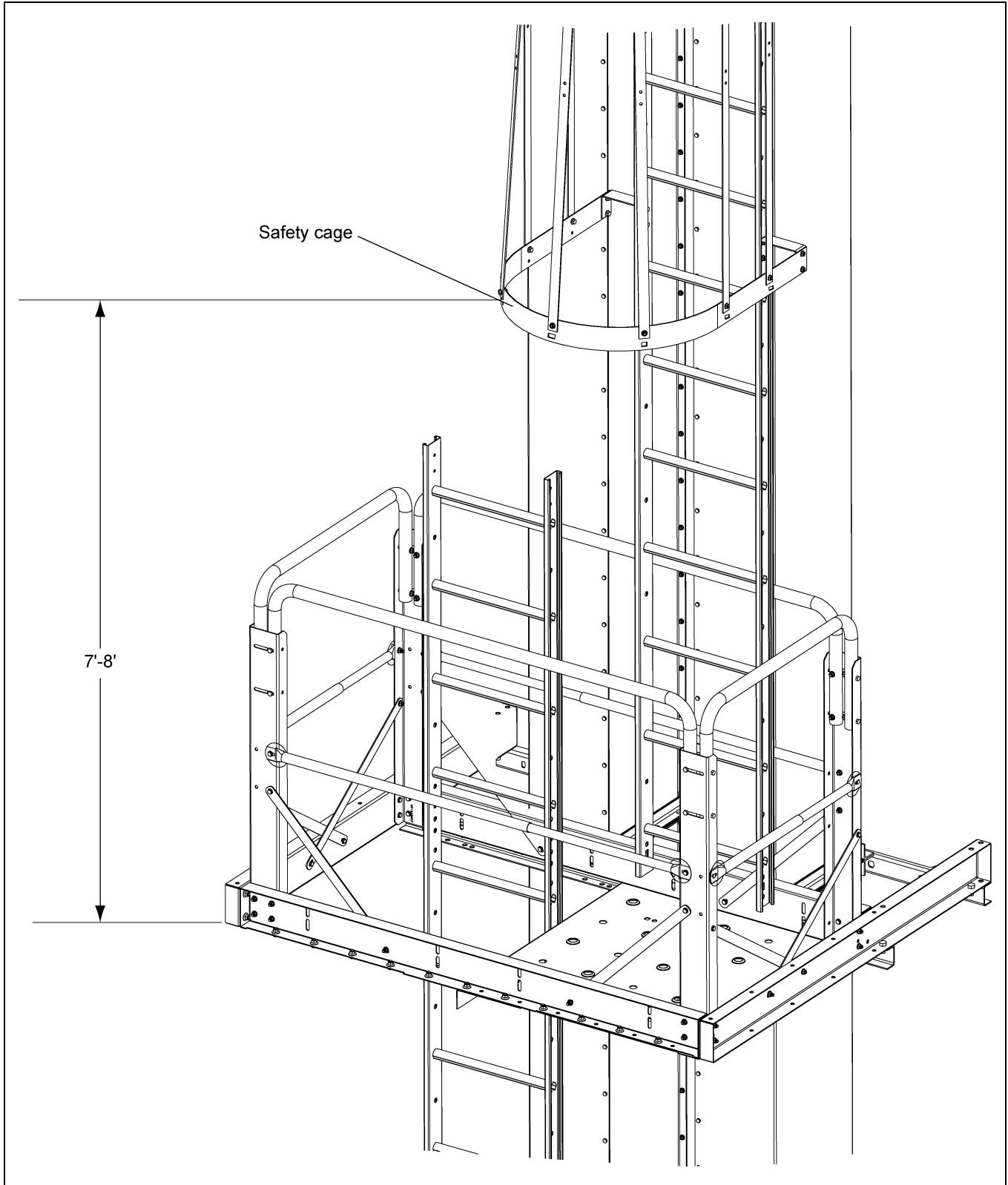

Figure 6N

Install Safety Cage

Safety cages are 10' sections, with the exception of the 3' entrance section.

1. Locate safety cage hoops (LDR-BCKTBHP) along the ladder rails where the safety cage hoops will be installed. **NOTE:** *The end hoops of a 10' section are spaced 4' from the two (2) middle hoops, which are spaced 2' apart. See Figure 60 for spacing. (See Figure 60.)*

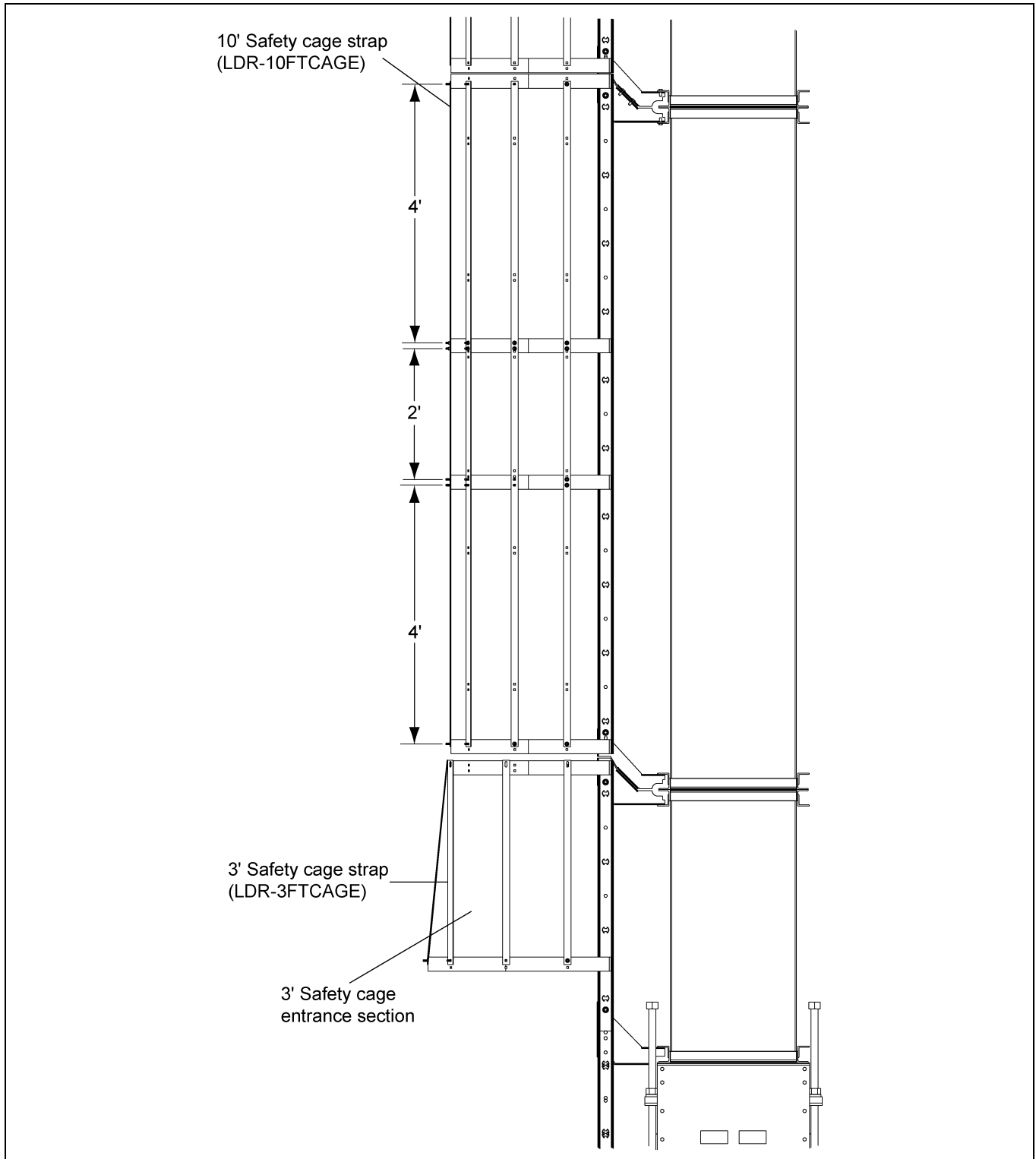

Figure 60 10' Safety Cage Section

6. Tie Angles, Ladders and Safety Cages

2. Attach safety cage hoops to ladder using 1/2" x 1" bolts and nuts. (See Figure 6P.)

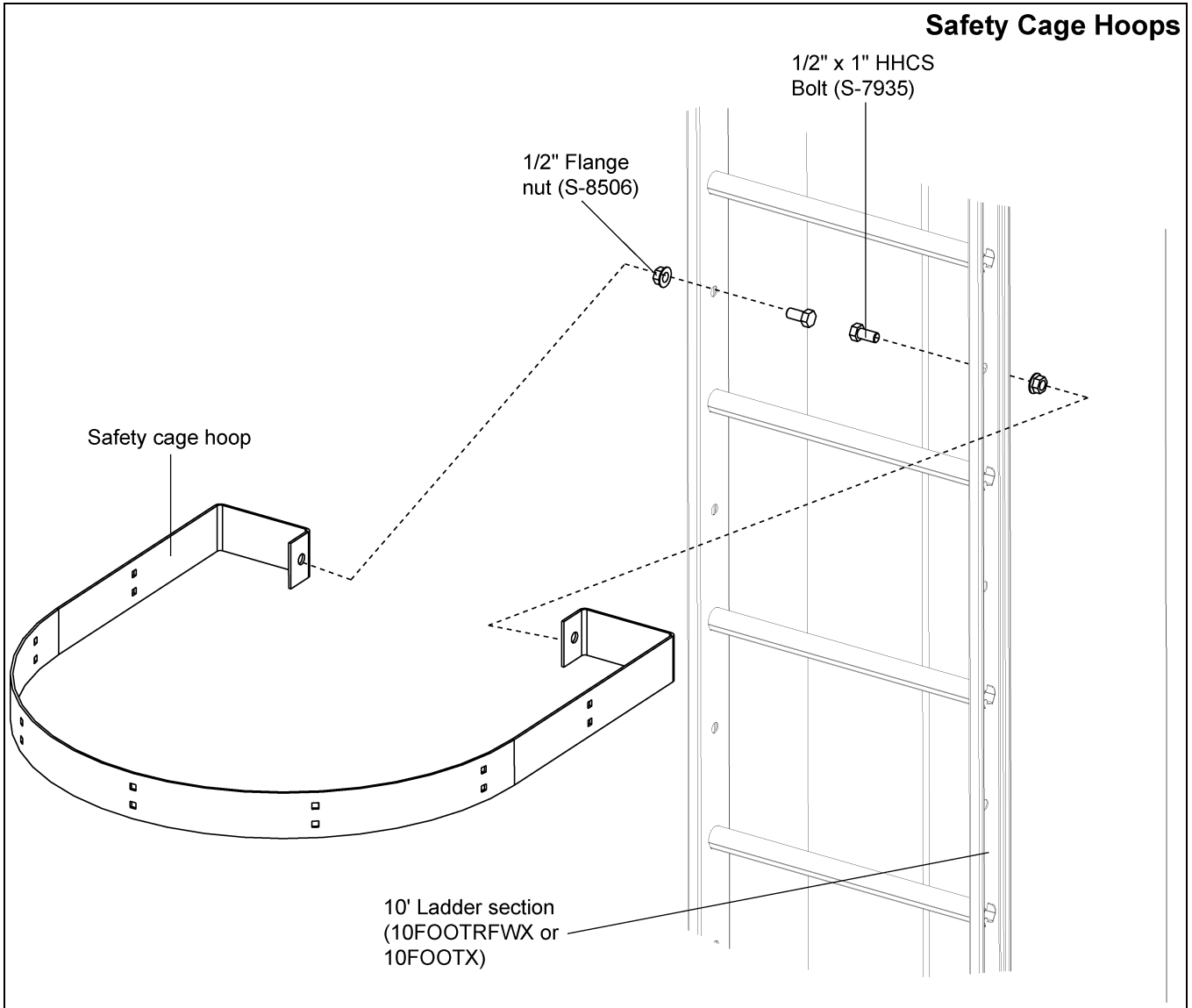

Figure 6P

6. Tie Angles, Ladders and Safety Cages

3. Install the seven (7) 10' safety cage straps along the safety cage hoops using 5/16" x 3/4" bolts and nuts. **NOTE:** Bolt heads should be to the inside of the hoop. (See Figure 6Q.)

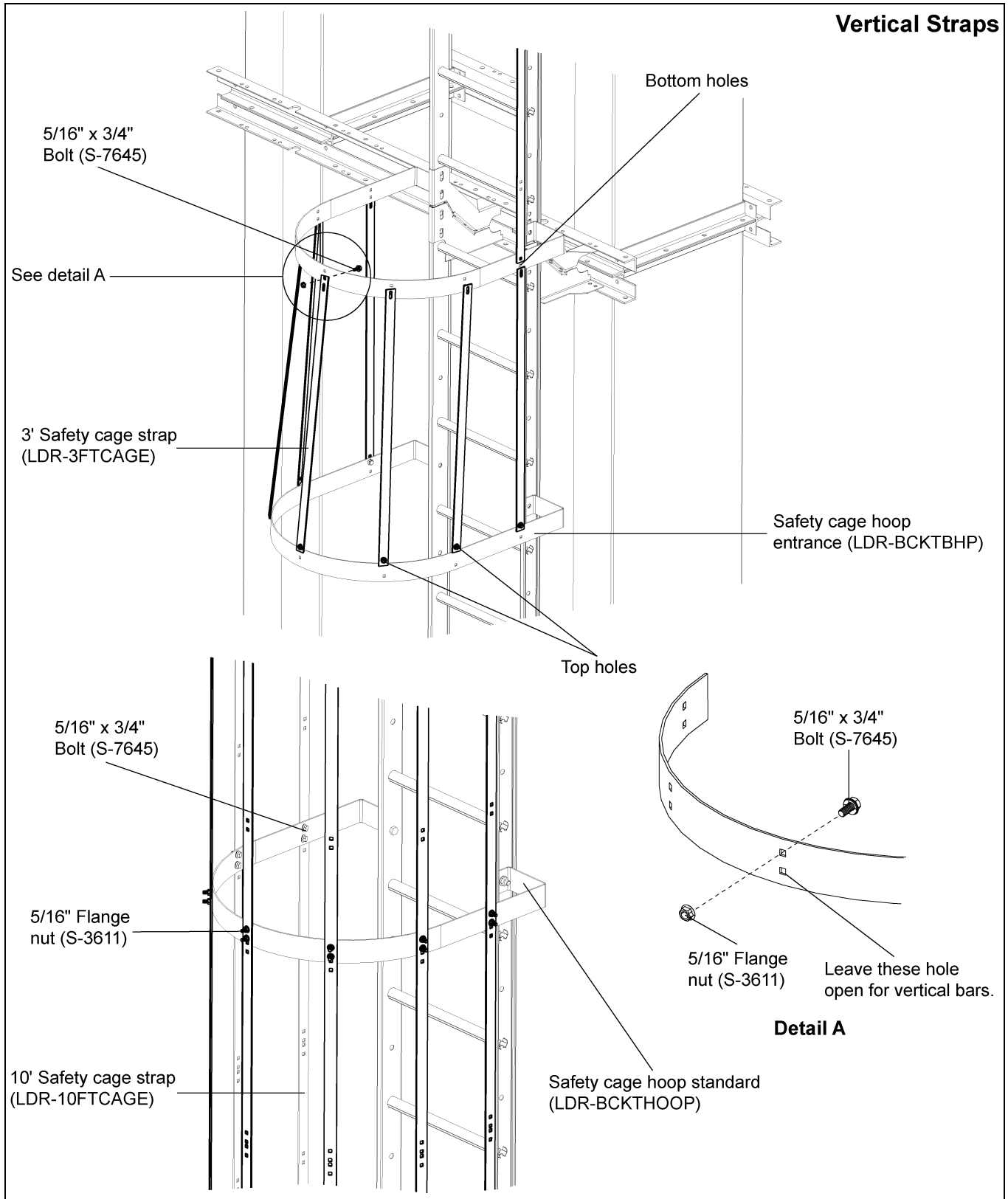

Figure 6Q

Chapter 7: Rest Platform

Rest Platform Tie Angles to Bucket Elevators

1. Install rest platform tie angles to the lower trunking on both the ladder side and non-ladder side of the trunking. Use 1/2" x 1" bolts through the bolt holes indicated for the bucket elevator size being installed. (See Figure 7A.)

NOTE: Bolt hole starting location on left side of tie angle is marked with the bucket size.

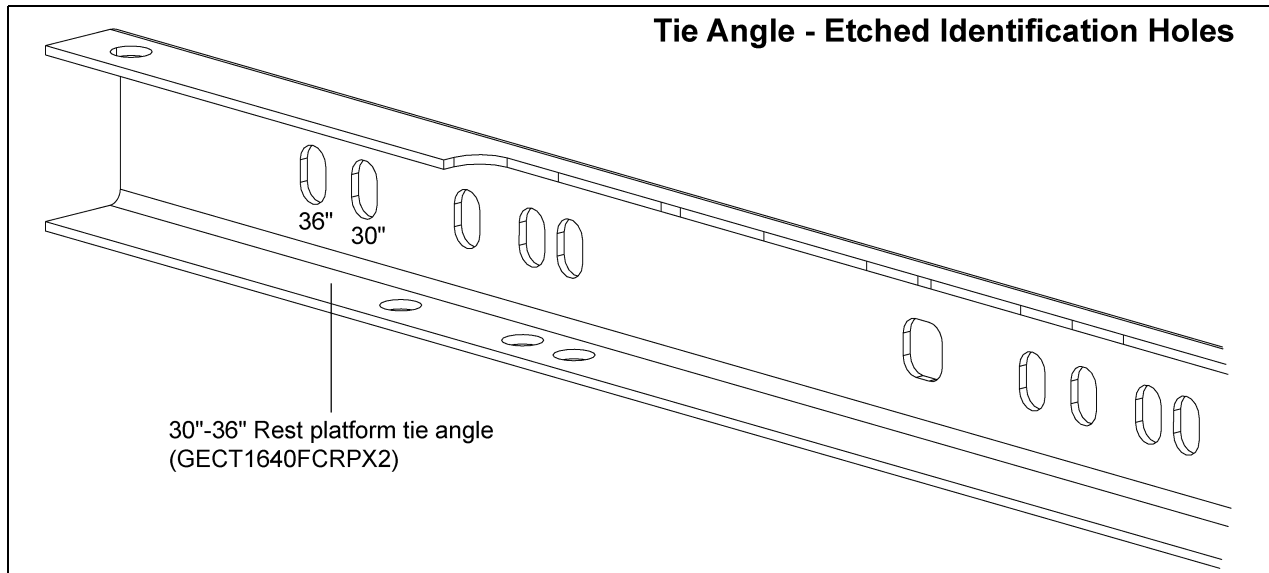

Figure 7A Tie Angle with Etched Numbers

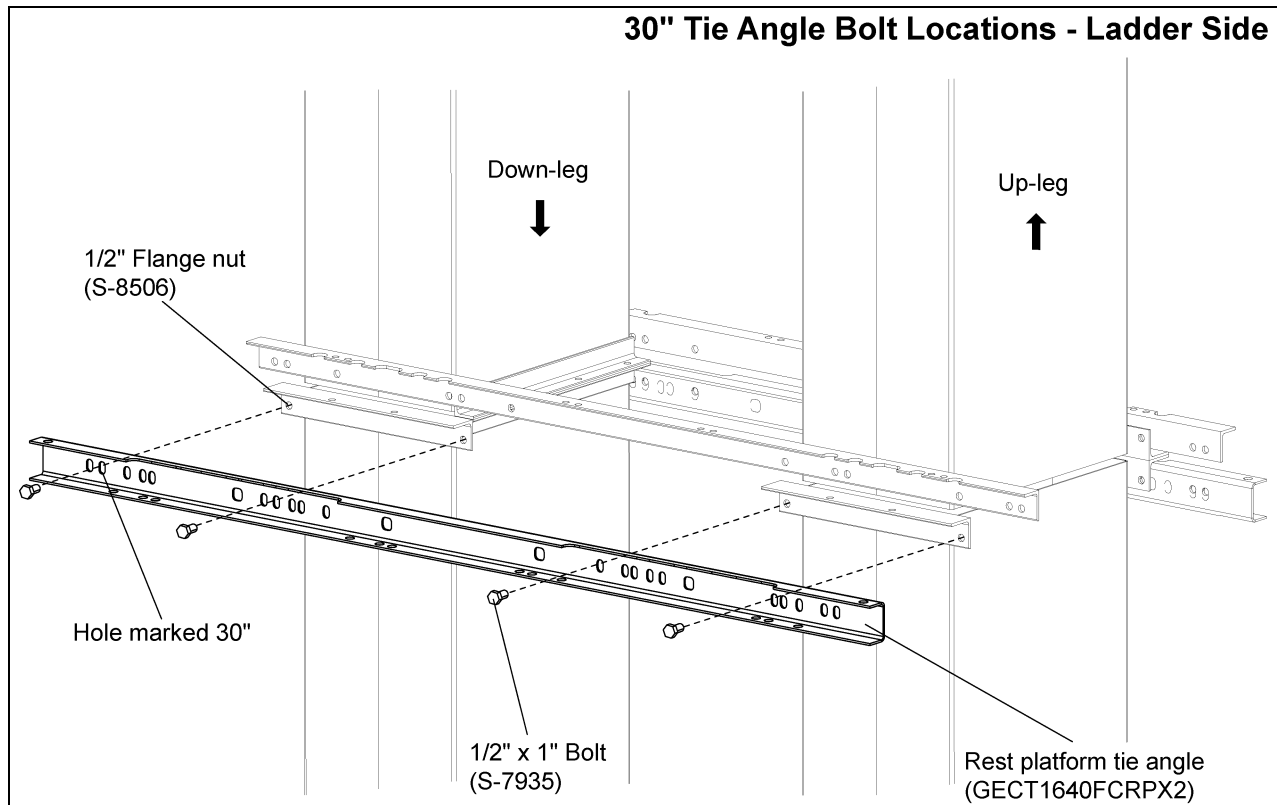

Figure 7B 30" Rest Platform Tie Angle Bolt Locations - Ladder Side

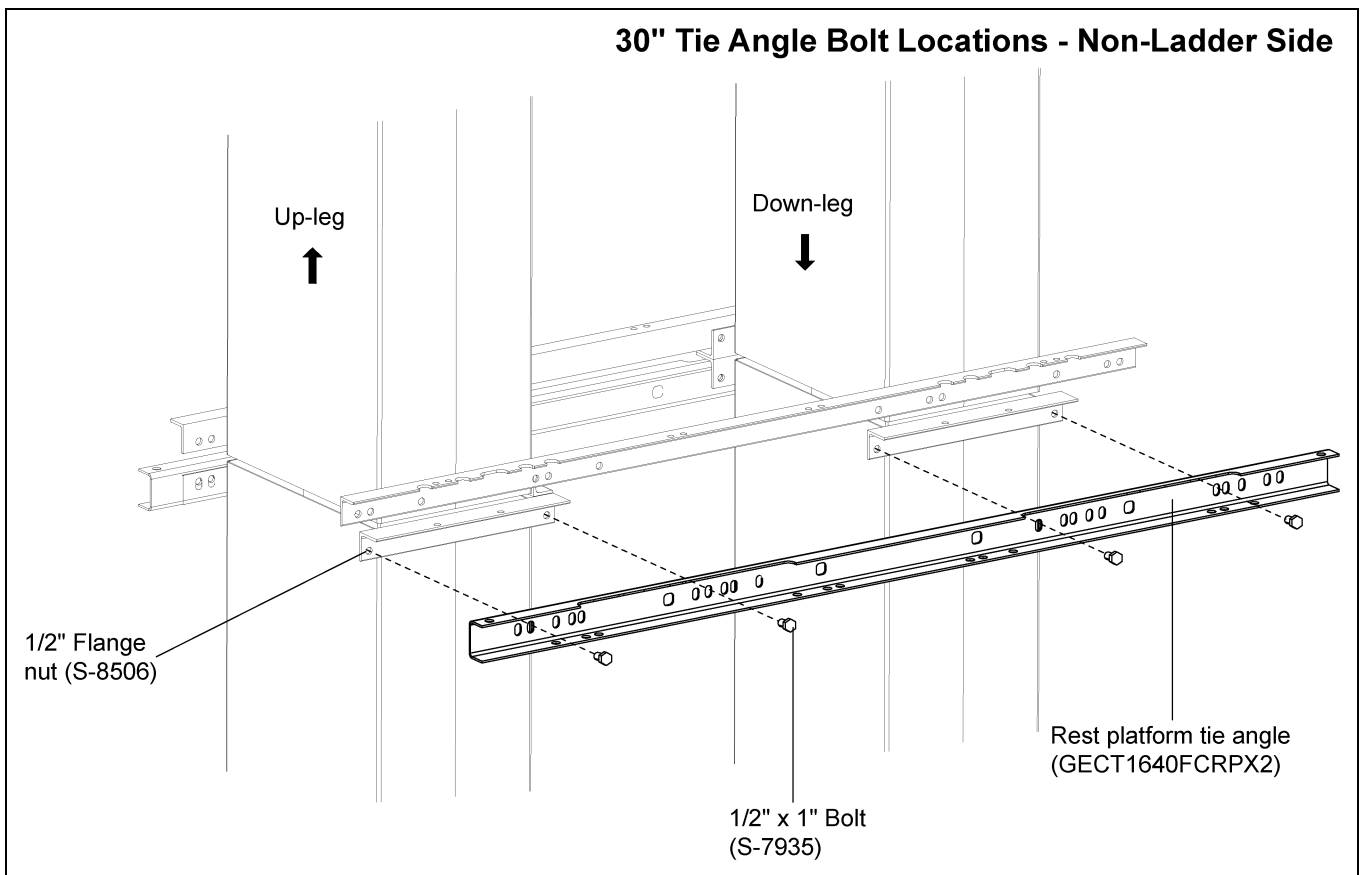

Figure 7C 30" Rest Platform Tie Angle Bolt Locations - Non-Ladder Side

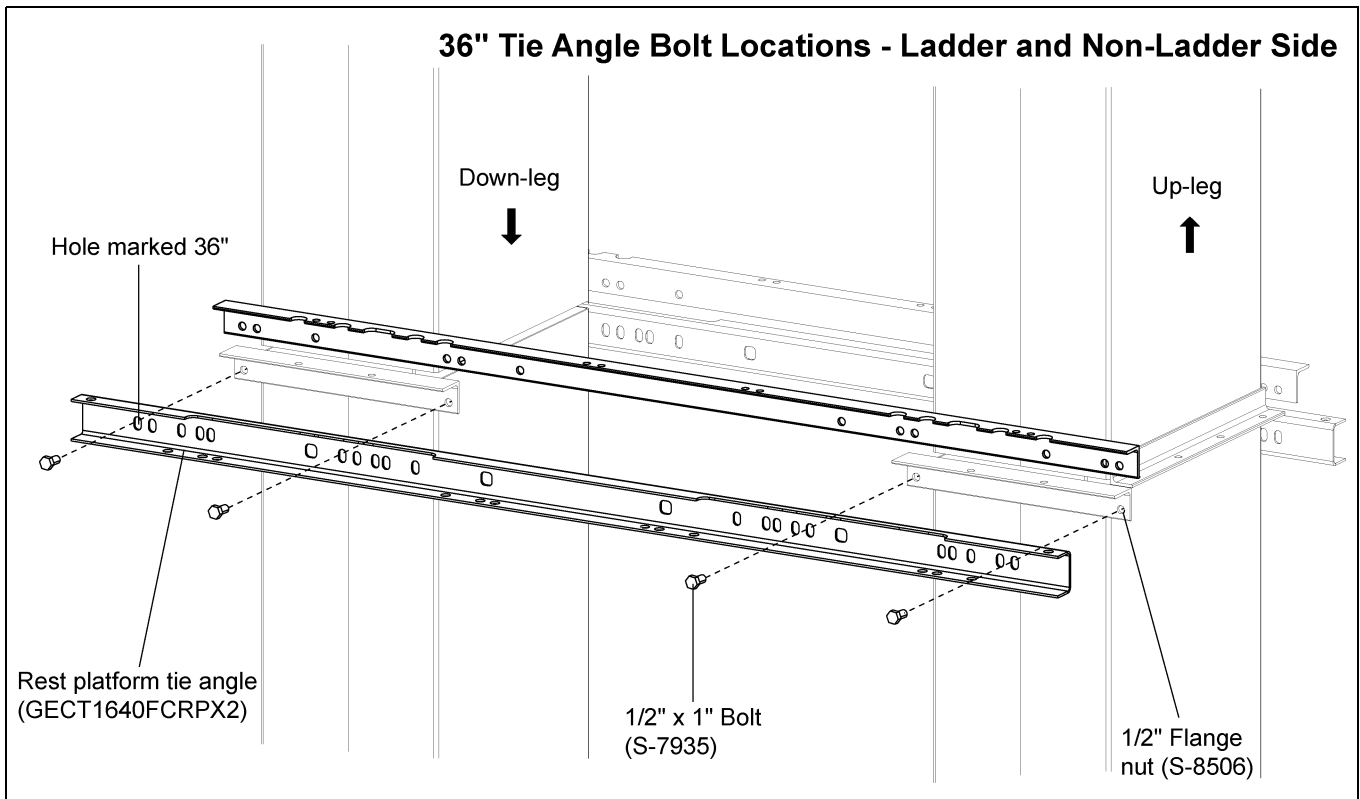

Figure 7D 36" Rest platform tie angle bolt locations - Ladder and non-ladder side have the same bolt hole locations.

7. Rest Platform

Attach Rest Platform Channel to the Rest Platform Tie Angle

1. Connect rest platform mounting channels to the rest platform tie angles using 1/2" x 1" bolts. Bolt hole locations for 30"-36" bucket elevator will be the same. (See Figure 7E.)

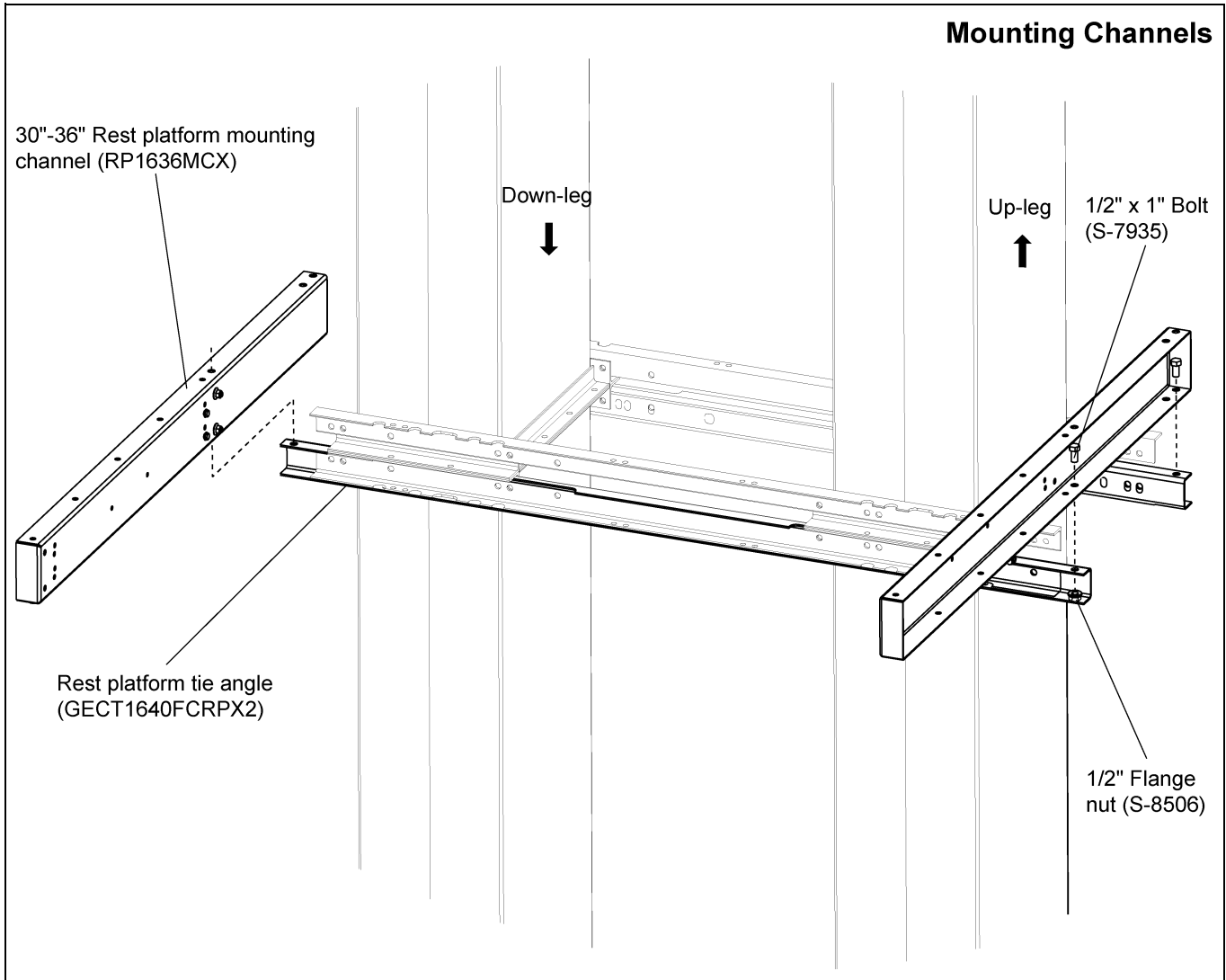

Figure 7E Bolt hole locations for 30"-36" rest platform mounting channels to tie angles.

Rest Platform Cross Channel to Rest Platform Mounting Channels

1. Place the rest platform cross channels between the rest platform mounting channels and connect those using 3/8" x 3/4" hex bolts. (See Figure 7F.)

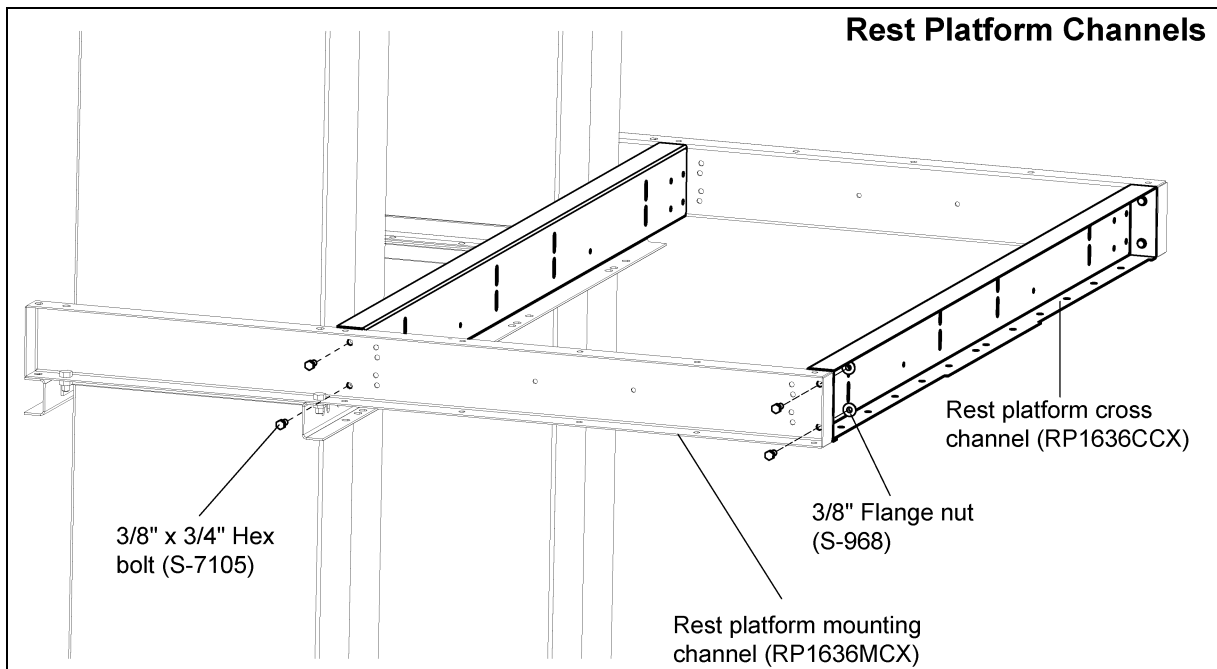

Figure 7F Rest Platform Cross Channel to Rest Platform Mounting Channels

2. Attach rest platform deck to the bottom of the rest platform mounting channels and rest platform cross channels, using 3/8" x 3/4" hex bolts. Bolt heads should be installed against the deck plate. (See Figure 7G.) **NOTE:** The deck plate can be mounted on either the right or left side, but the flange must be mounted towards the opening.

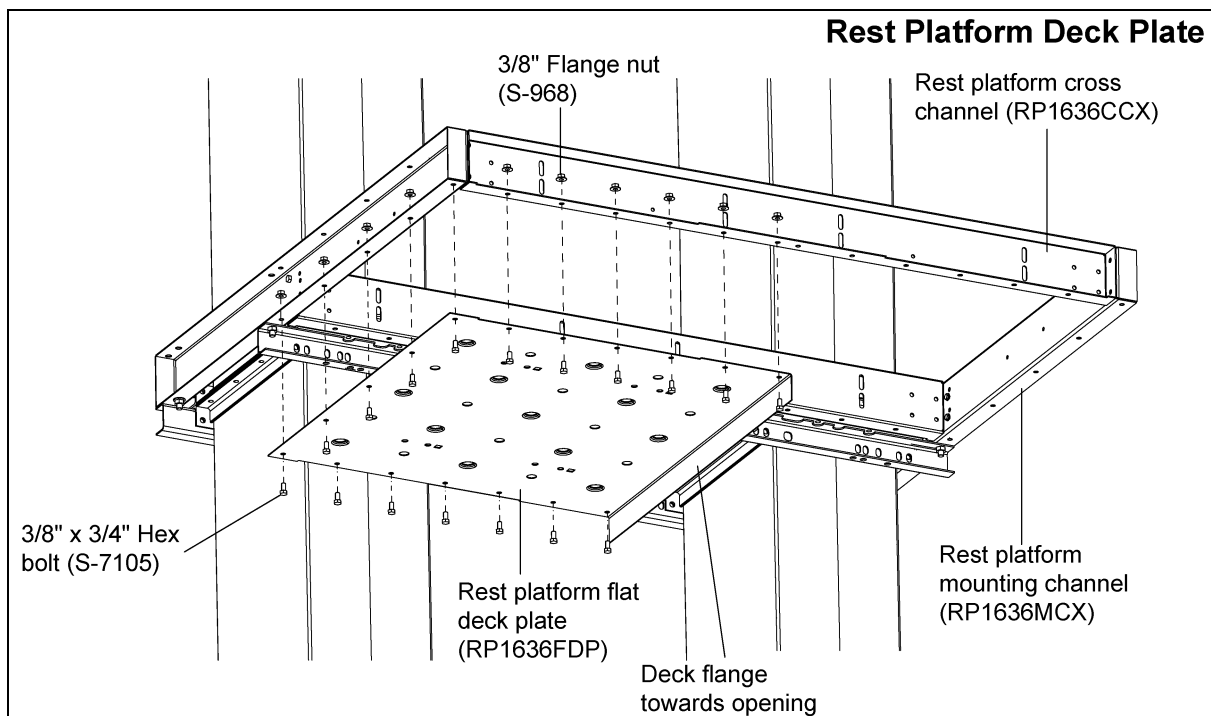

Figure 7G Deck Plate

7. Rest Platform

3. Install the handrail platform posts to the rest platform mounting channels and rest platform channels using six (6) 5/16" x 3/4" flanged hex bolts for each post, four (4) bolt to the front and two (2) on the side. (See Figure 7H.)

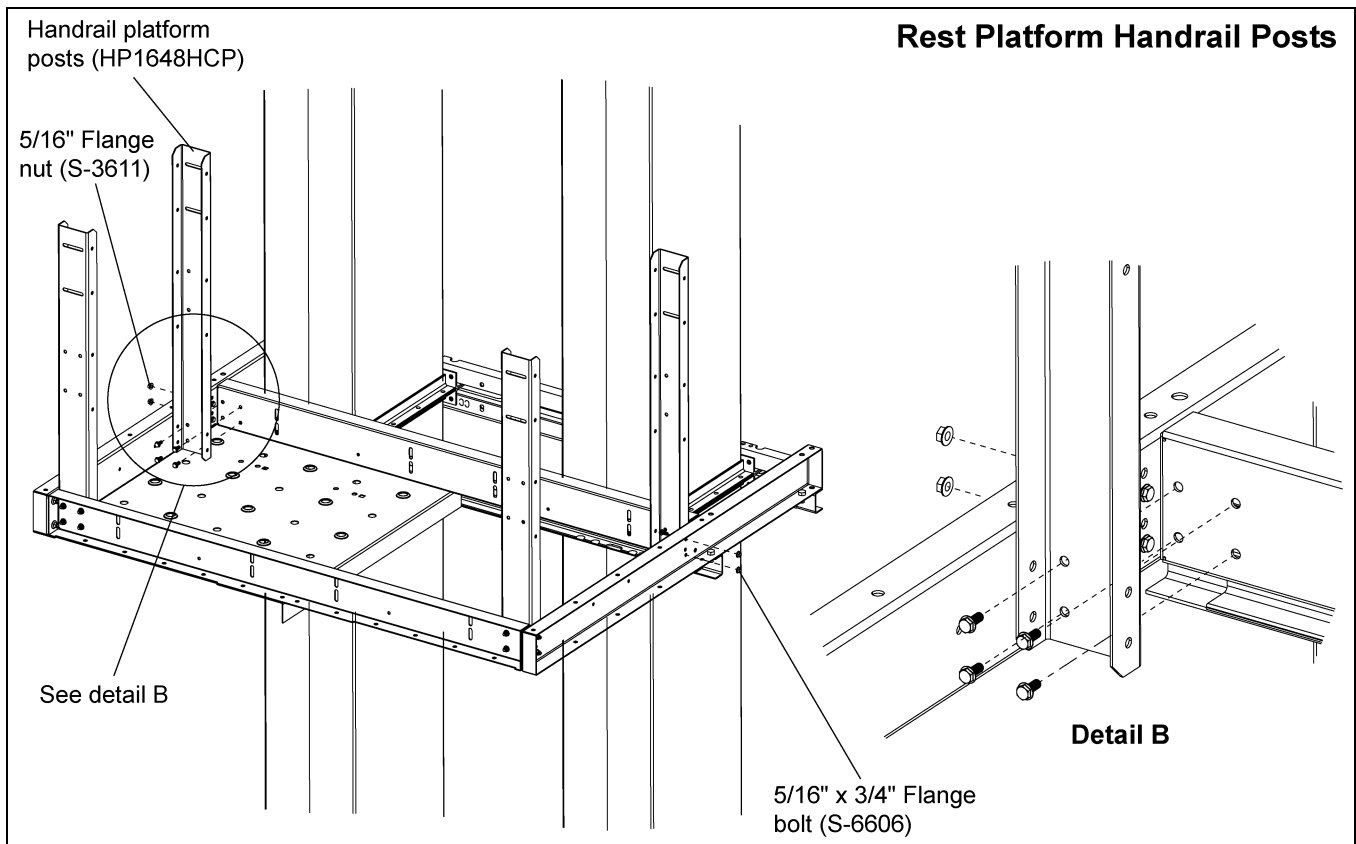

Figure 7H

4. Assemble the intermediate handrails by sliding the small handrail into the larger handrail to create a telescoping handrail that can be adjusted to the correct length between the posts. Two (2) of the small intermediate handrails and two (2) of the large intermediate handrails will need to be cut to fit. The starting length of each rail is 36". Cut 18" off the end of each rail so the final length of each rail is 18". (See Figure 7I.)

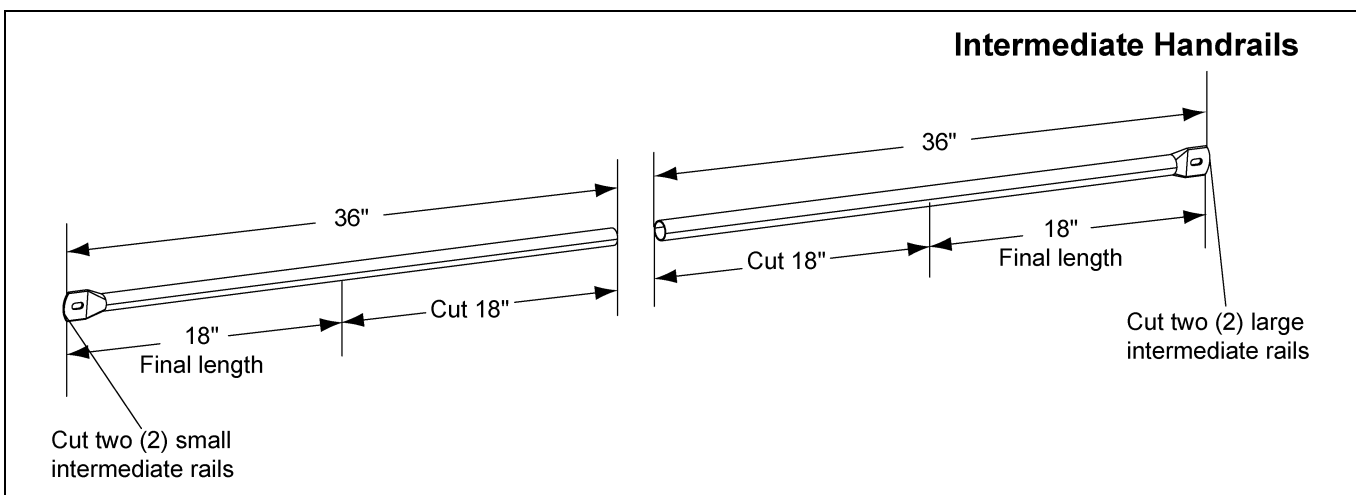

Figure 7I

5. Install the front and back intermediate handrails to the platform posts using 5/16" x 3/4" flanged hex bolts. Adjust the rail into position by sliding it out to the correct length.
6. After cutting the two (2) large and two (2) small intermediate handrails, slide them to the correct length and install them to the handrail posts on the short sides of the platform using 5/16" x 3/4" flanged hex bolts. (See Figure 7J.)

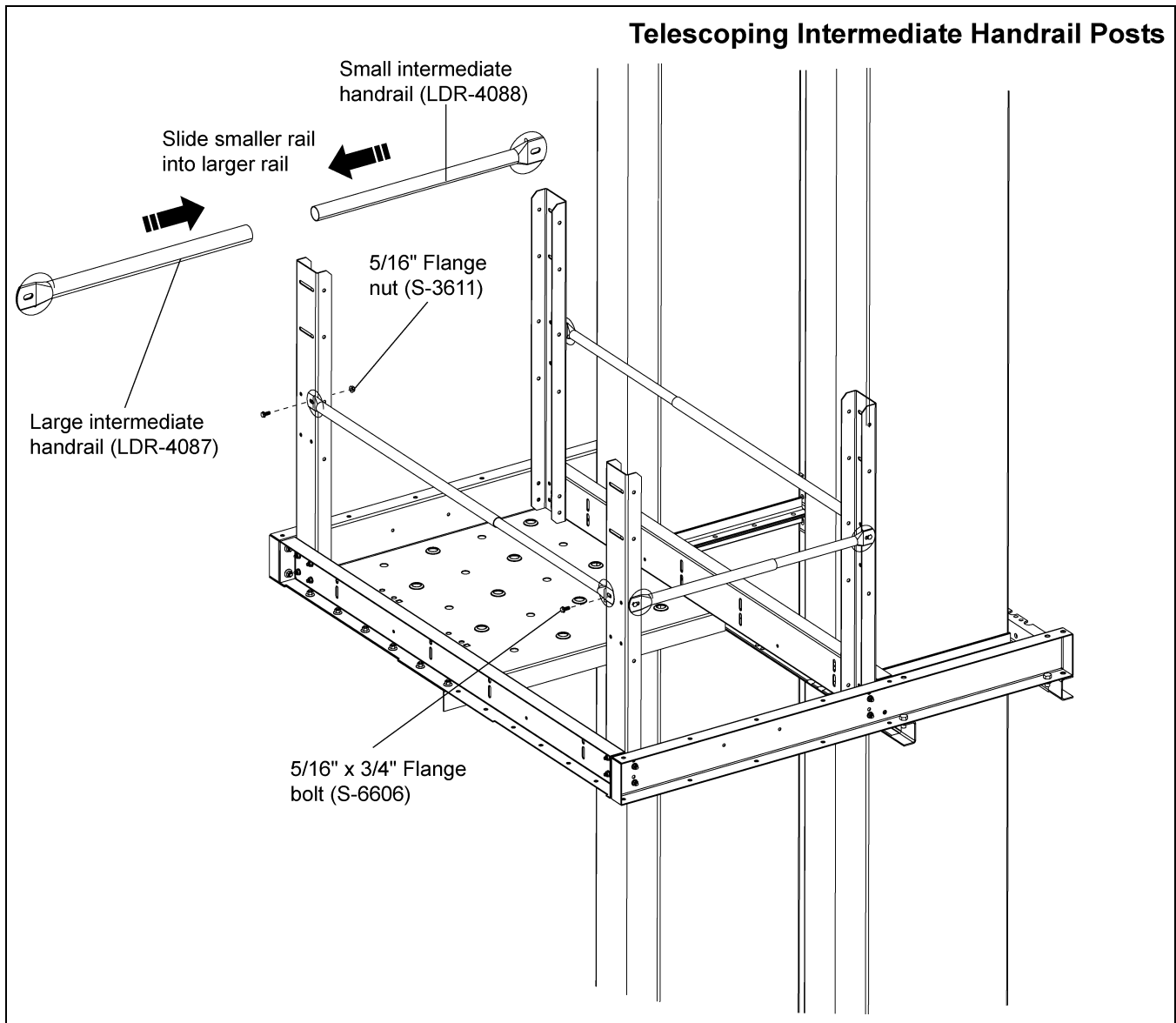

Figure 7J

7. Rest Platform

7. Connect the front rest platform handrails and the side rest platform handrails to the handrail platform post using 5/16" x 2" hex bolts. (See Figure 7K.)

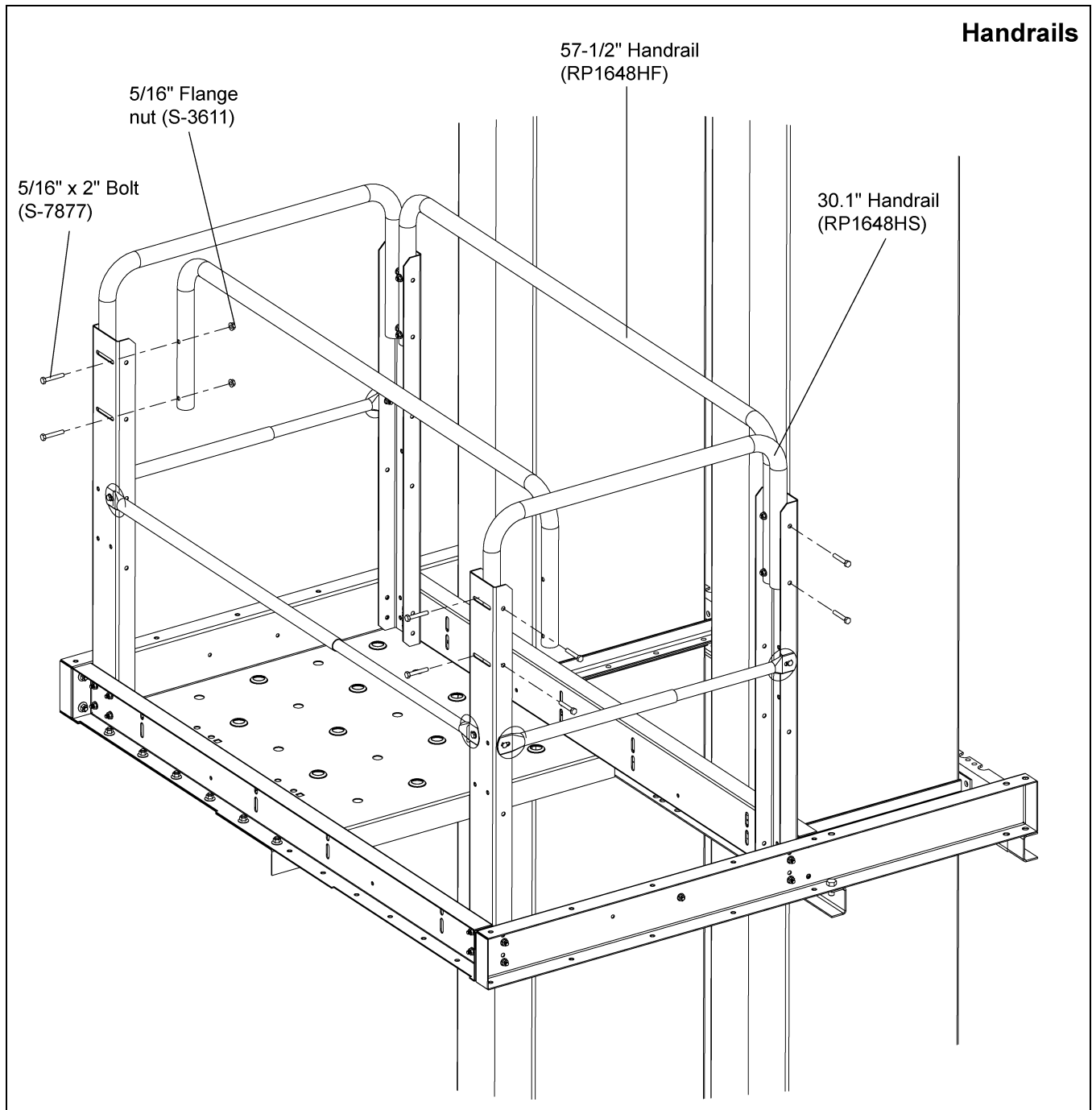

Figure 7K

8. Platform braces must be installed from handrail posts to mounting and cross channels using 5/16" x 3/4" flanged hex bolts. Braces should be attached to the outside of the platform post and to the inside of the mounting and cross channels. **NOTE:** Safety cage bars (LDR-5171BE) are used as platform braces/tie angle braces through out this installation. Bolt heads should be on inside of platforms. (See Figure 7L.)

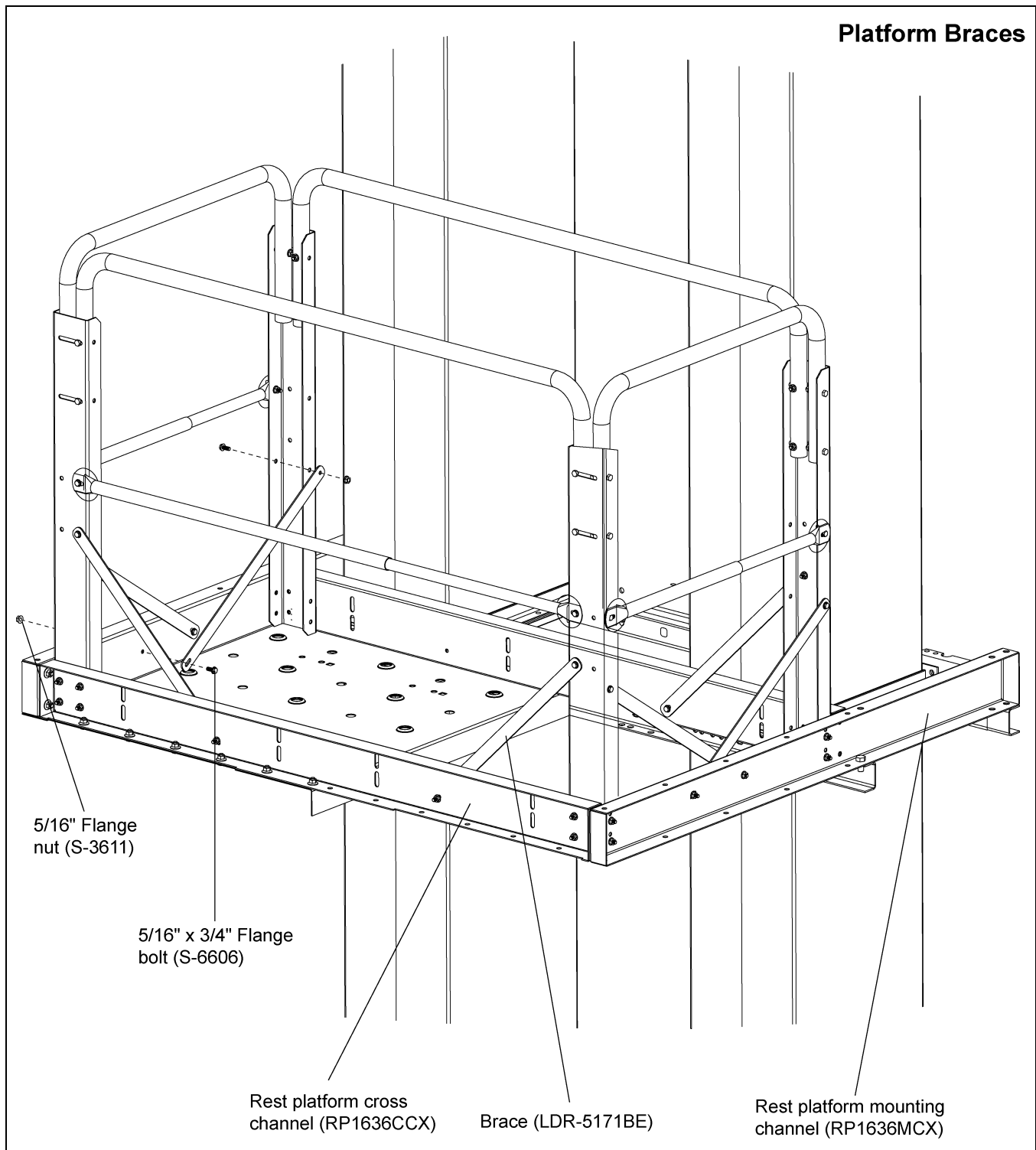

Figure 7L

7. Rest Platform

9. Install ladder support brackets to the rest platform cross channel using 3/8" x 3/4" hex bolts.
10. Attach ladders to ladder support brackets using 1/2" x 3/4" hex bolts. (See Figure 7M.)

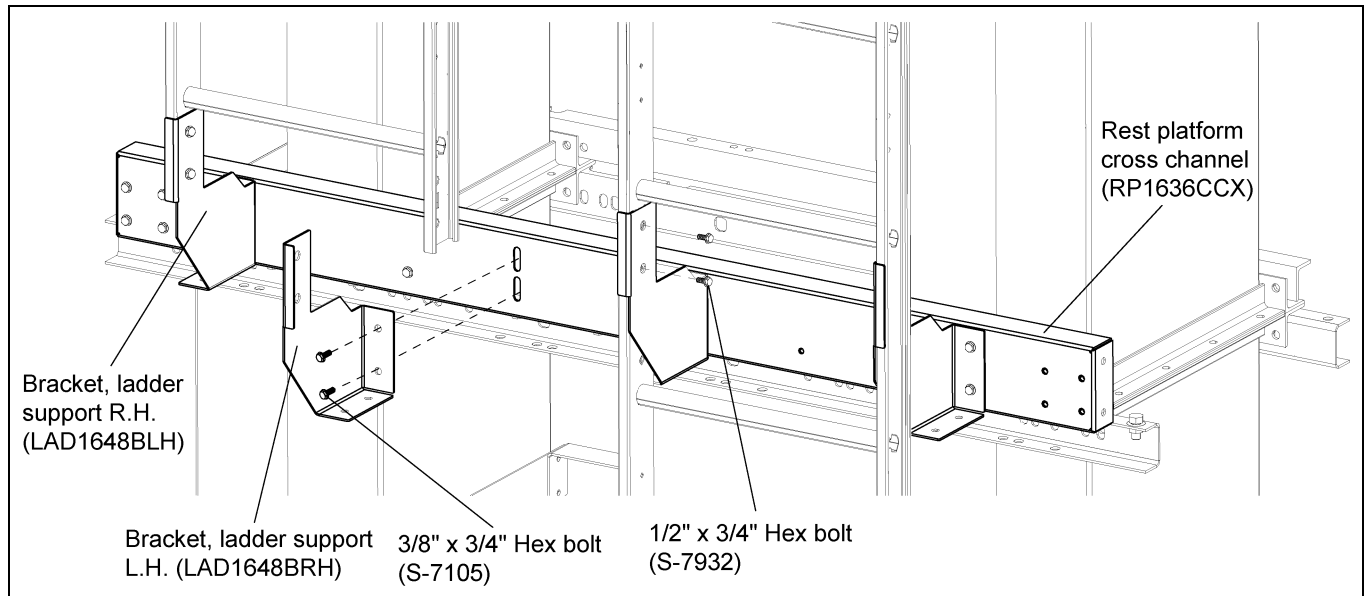

Figure 7M

Ladder Support

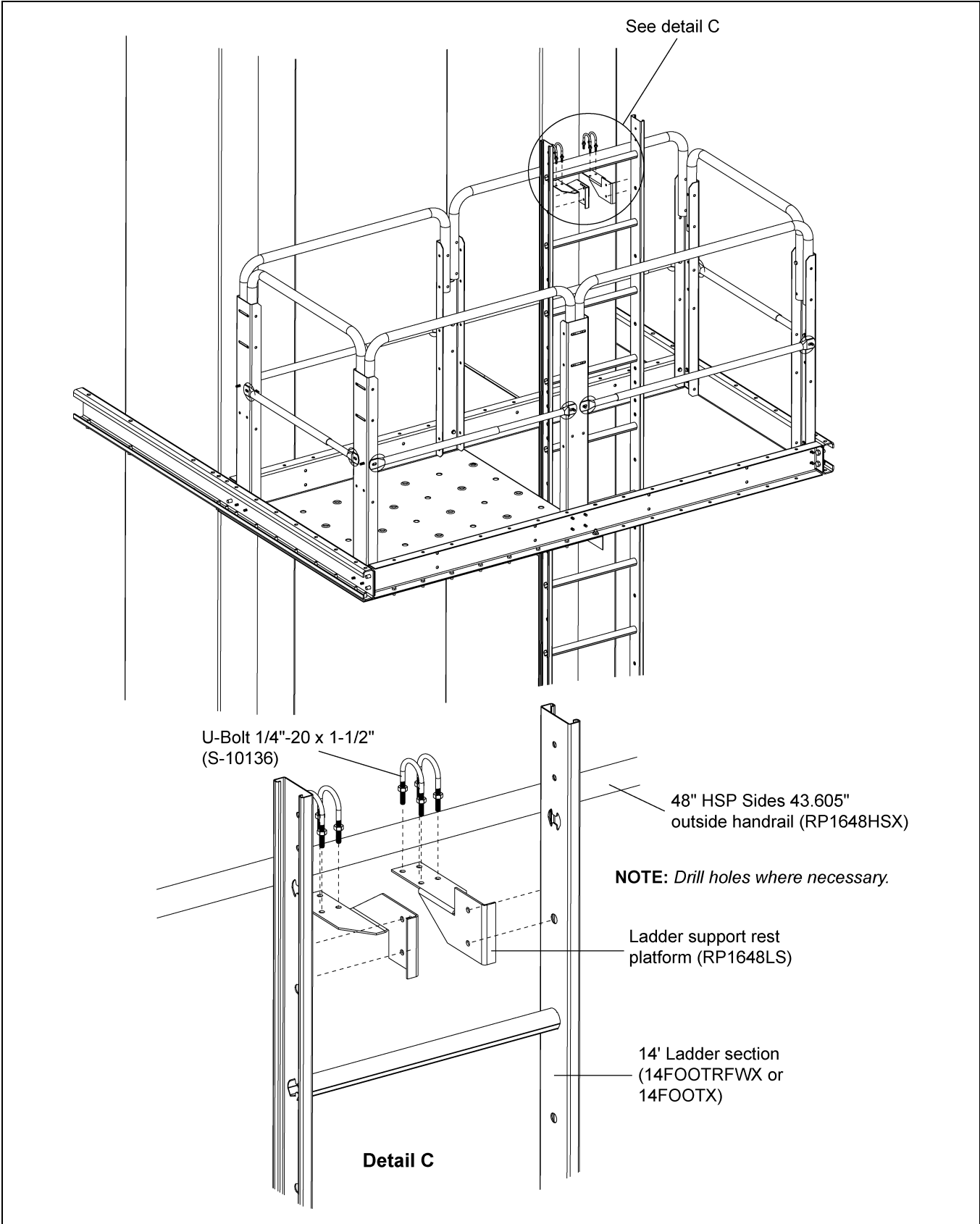

Figure 7N

Chapter 8: 30"-36" Head Platform Right Hand Drive

To facilitate quick and easy assembly, numerous parts are pre-assembled prior to shipping.

Considerable time is dedicated at the beginning of this manual to the proper orientation of channels and decks. This is because the orientation of these elements is essential to the proper construction of the head platform.

1. There are many ways to get the orientation wrong and only one way to get it right.
2. Proper orientation of the channels and decks is essential proper assembly.
3. Proper construction of the head platform can only be completed if the initial orientation of the channels is done correctly.

Therefore, we strongly advise you take time to confirm that the orientation of these early elements is correct before you begin to assemble the decking on to the channels.

To facilitate proper connections, major connecting holes are etched with alpha-numeric codes. One side is labeled **X1** through **X7**, this side is referred to as the “**X**” side. The opposite side is labeled with **Y1** through **Y7** and is referred to as the “**Y**” side.

Cross Deck Support Channels to Lower Head

Three (3) cross deck support channels support the platform. Two (2) of the channels are attached to brackets on the lower head section and the third channel is attached to the decking itself but is not attached directly to the lower head. This third channel will be attached after the deck is assembled.

(See Figure 8A.)

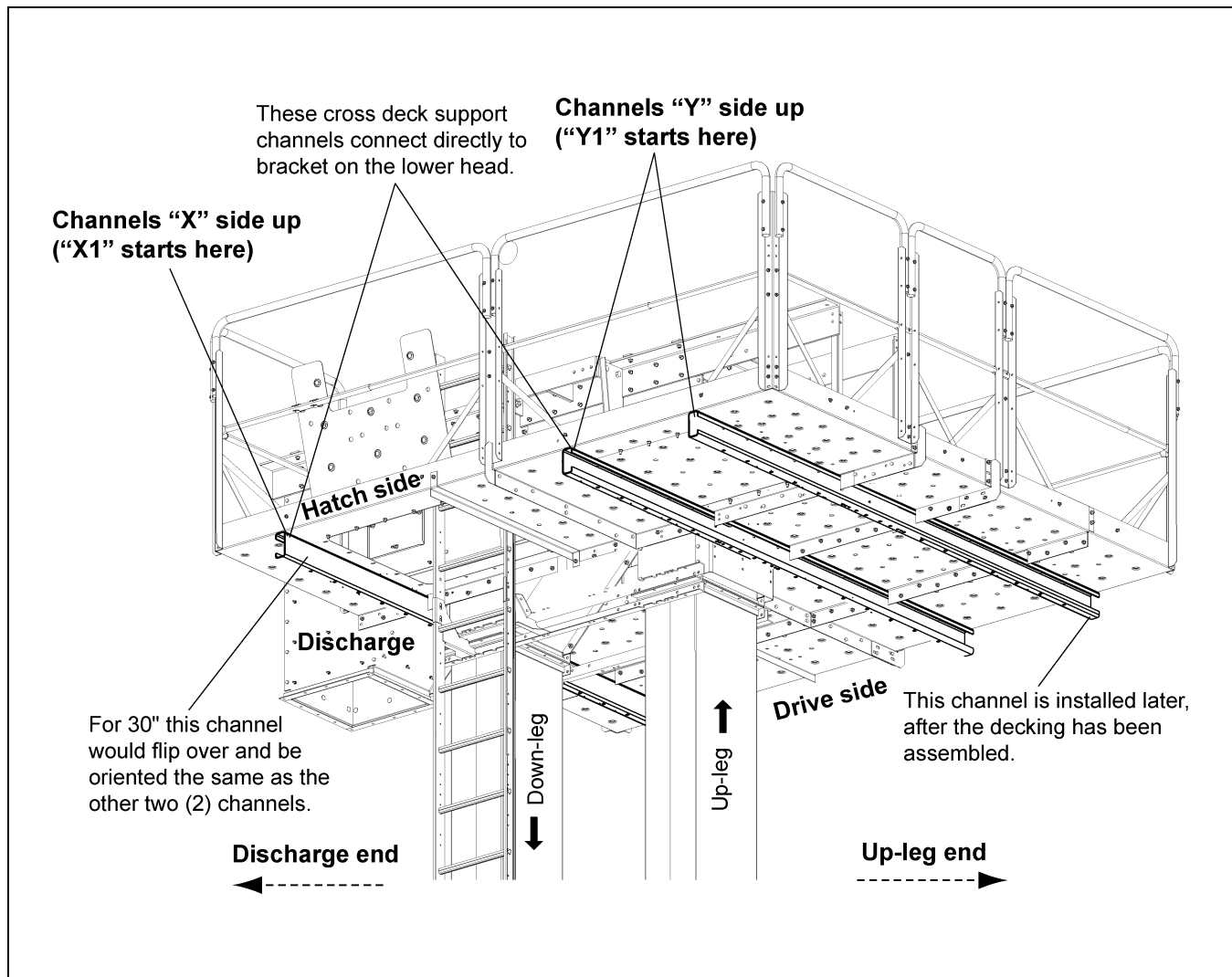

Figure 8A 30"-36" Platform Overview

Attach Main Support Channels to Lower Head

For 30" Right Side Drive

Orient the Channel

Place lower head section on solid and level surface.

1. At **Discharge End** orient the channel so that:
 - a. Channel opening is inward, toward the bracket.
 - b. Hole labeled with "Y" face up.
 - c. Holes **Y1** is on the non-drive/hatch side of the lower head.
 - d. Hole **Y7** is on the drive side of the lower head.
 - e. Cross deck support channel extends farther on the drive side than on hatch side of lower head.
2. At **Up-Leg End** orient the channel so that:
 - a. Channel opening outward, toward the up-leg end of the head.
 - b. Holes labeled with "Y" face up.
 - c. Hole **Y1** is on the non-drive side of the lower head.
 - d. Hole **Y7** is on the drive side of the lower head.
 - e. Cross deck support channel extends farther on the drive side than on hatch side of lower head.
(See [Figure 8C on Page 47.](#))
3. Attach cross deck support channels (HP36DSCX) to the top-most set of holes of the lower head brackets (HSP36130) using 3/8" x 1" bolts and nuts and properly. (See [Figure 8C on Page 47.](#))

***NOTE:** *The channels MUST be oriented as shown in [Figure 8B and Figure 8C on Page 47](#) in order for the decking and subsequent assembly to be done correctly.*

8. 30"-36" Head Platform Right Hand Drive

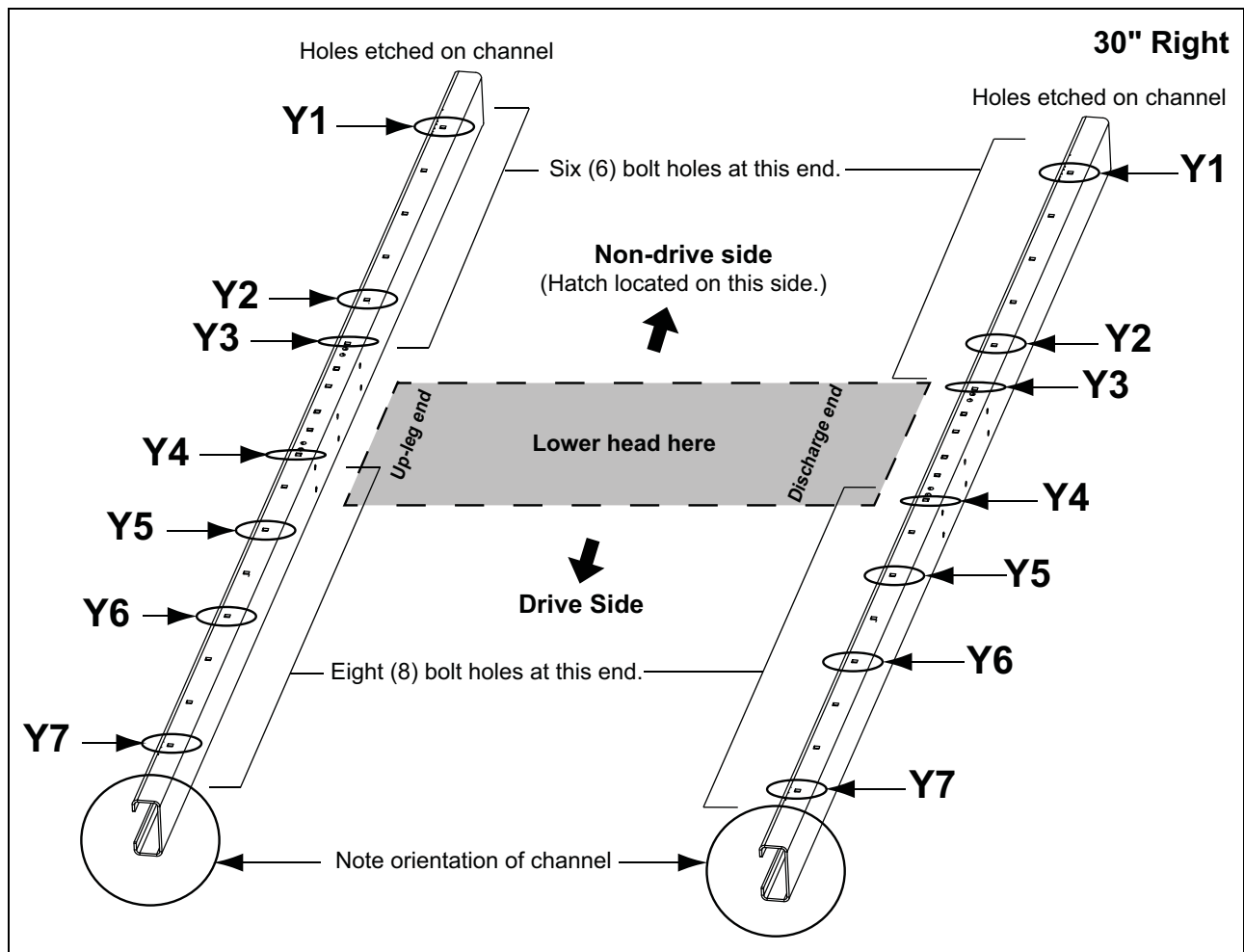

Figure 8B 30" Right Side Drive Channel Position

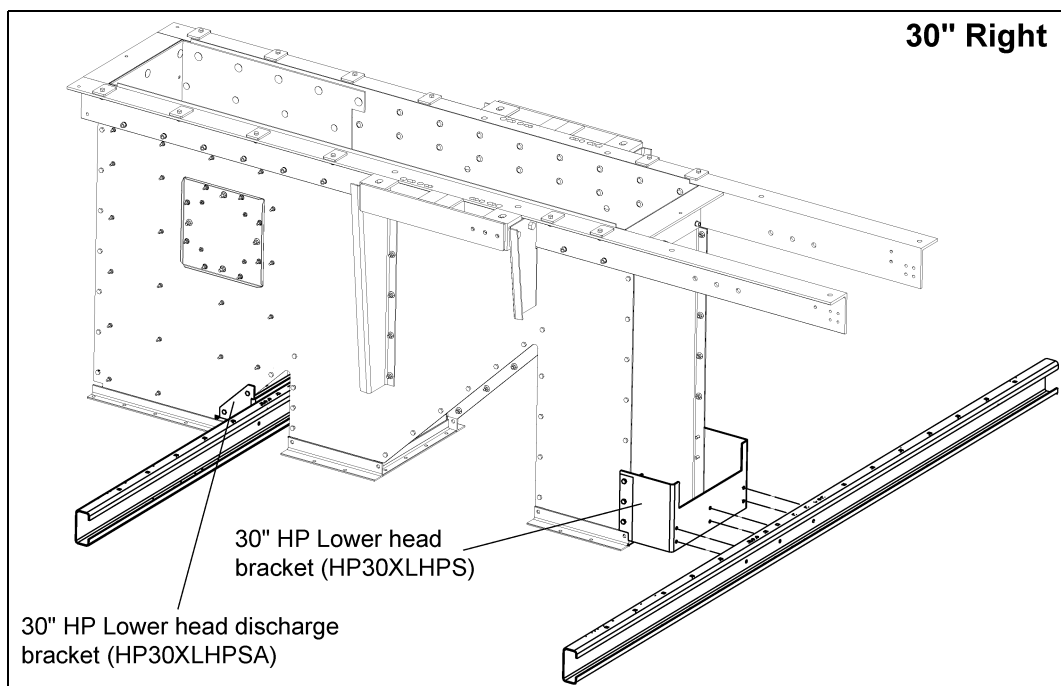

Figure 8C 30" Right Drive - Cross Deck Support Channels to Lower Head Brackets

8. 30"-36" Head Platform Right Hand Drive

For 36" Right Side Drive

Orient the Channel

Place lower head section on solid and level surface.

1. At the **Discharge End** orient the channel so that:
 - a. Channel opening is outward, toward the discharge end of the head.
 - b. Holes labeled with "X" face up.
 - c. Hole **X1** is on the non-drive side of the lower head.
 - d. Hole **X7** is on the drive side of the lower head.
 - e. Cross deck support channel extends farther on the drive side than on hatch side of lower head.
 2. At the **Up-Leg End** orient the channel so that:
 - a. Channel opening outward, toward the up-leg end of the head.
 - b. Holes labeled with "Y" face up.
 - c. Hole **Y1** is on the non-drive side of the lower head.
 - d. Hole **Y7** is on the drive side of the lower head.
 - e. Cross deck support channel extends farther on the drive side than on hatch side of lower head.
(See Figure 8D on Page 49.)
 3. Attach cross deck support channels (HP36DSCX) to the top-most set of holes of the lower head brackets (HSP36130) using 3/8" x 1" bolts and nuts and torque properly. *(See Figure 8E on Page 49.)*
- *NOTE:** *The channels MUST be oriented as shown in Figure 8D and Figure 8E on Page 49 in order for the decking and subsequent assembly to be done correctly.*

8. 30"-36" Head Platform Right Hand Drive

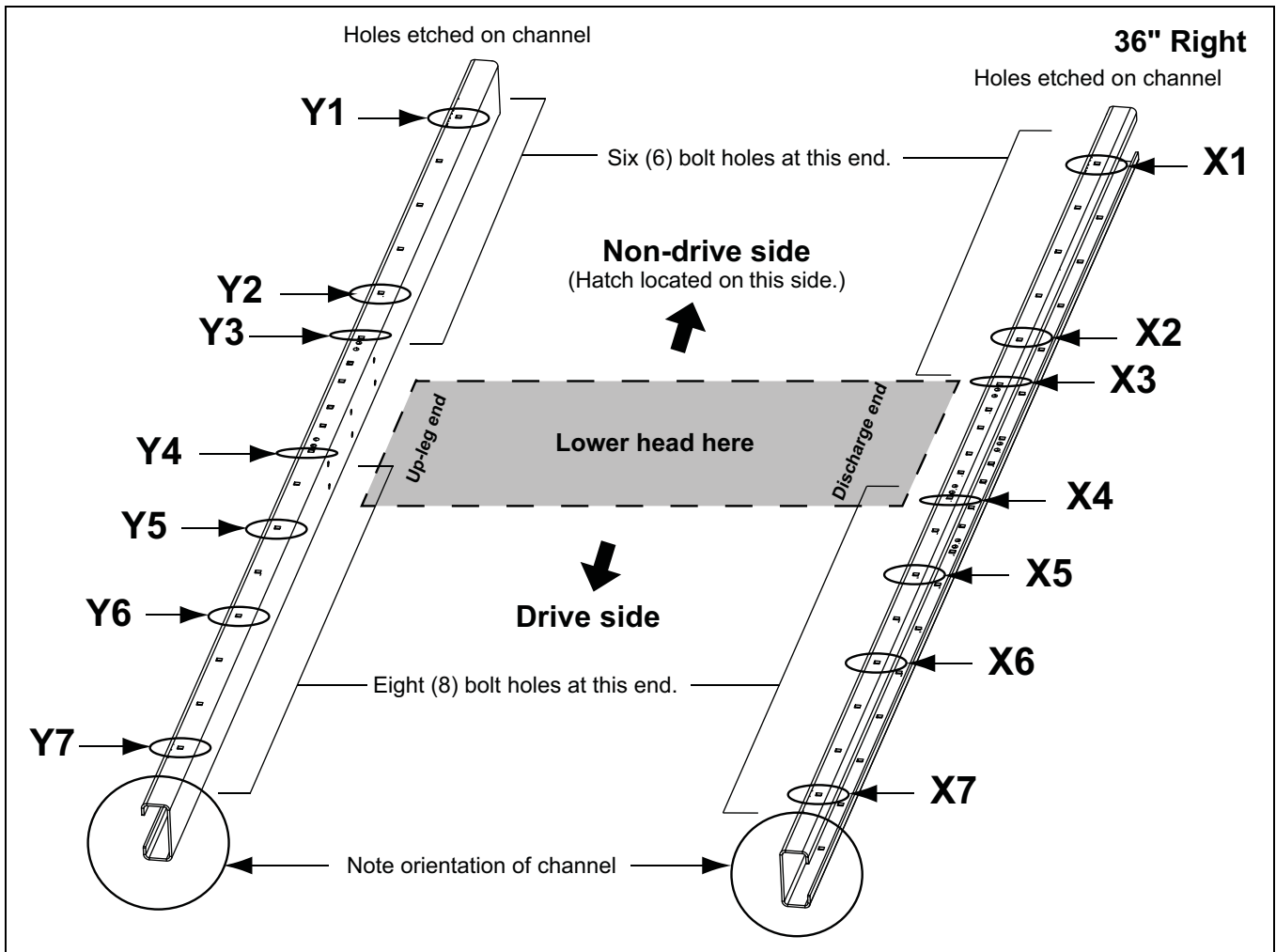

Figure 8D 36" Right Side Drive Channel Position

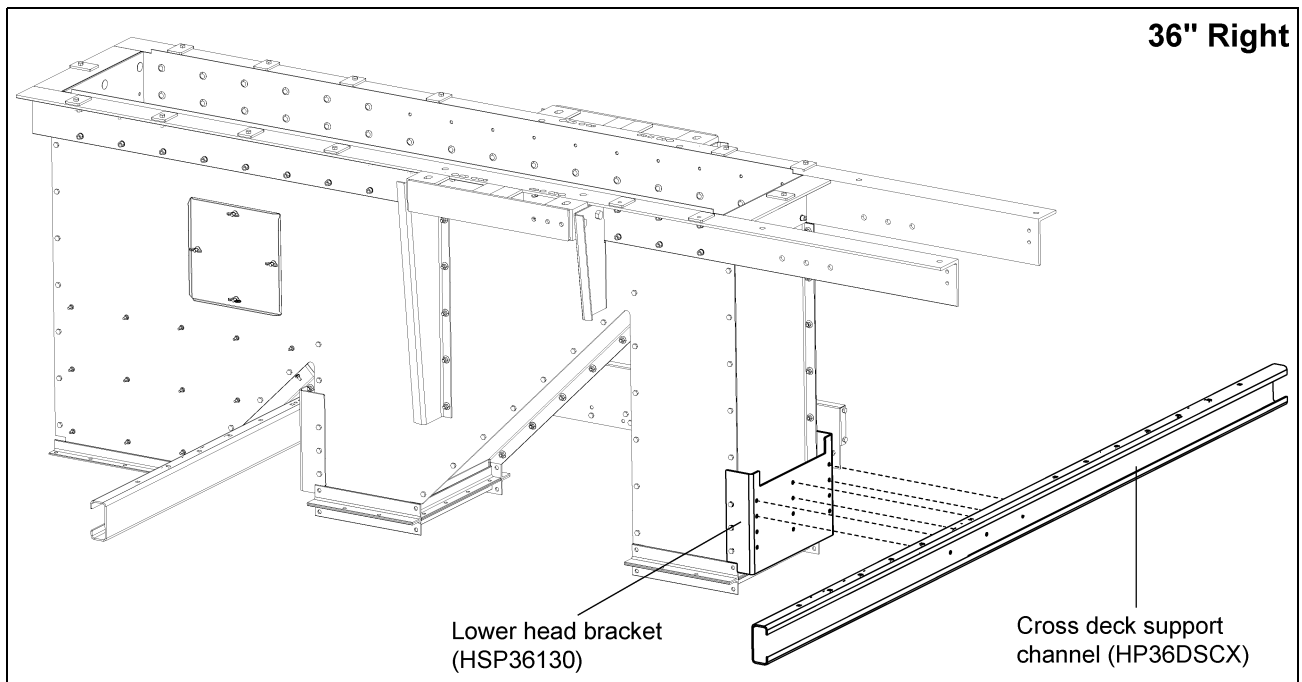

Figure 8E

8. 30"-36" Head Platform Right Hand Drive

Attach Deck A to Hatch Cover Plate

NOTE: Only two (2) side of deck plate are attached at this time.

1. Locate pre-assembled Deck A. This plank consists of the two (2) hatch openings and is labeled with holes etched with the letter A.
2. Orient Deck A so the hatch cover plate is at the up-leg end of the deck.
3. The hatch will be located at the discharge end and will remain open at this time. A hatch door will be attached to Deck A later and should NOT be installed at this time.

NOTE: ONLY connect the hatch filler plate along two (2) of the four (4) sides of the plate.

4. The holes perpendicular to the length of Deck A should remain open at this time as they will serve to connect the hatch cover plate and Deck A to the cross deck support channel.
5. Attach the hatch cover plate to Deck A using (8) eight 3/8" x 1" carriage bolts (S-3585) with flange nuts (S-10028) and torque to 30 ft/lbs. (See Figure 8F.)

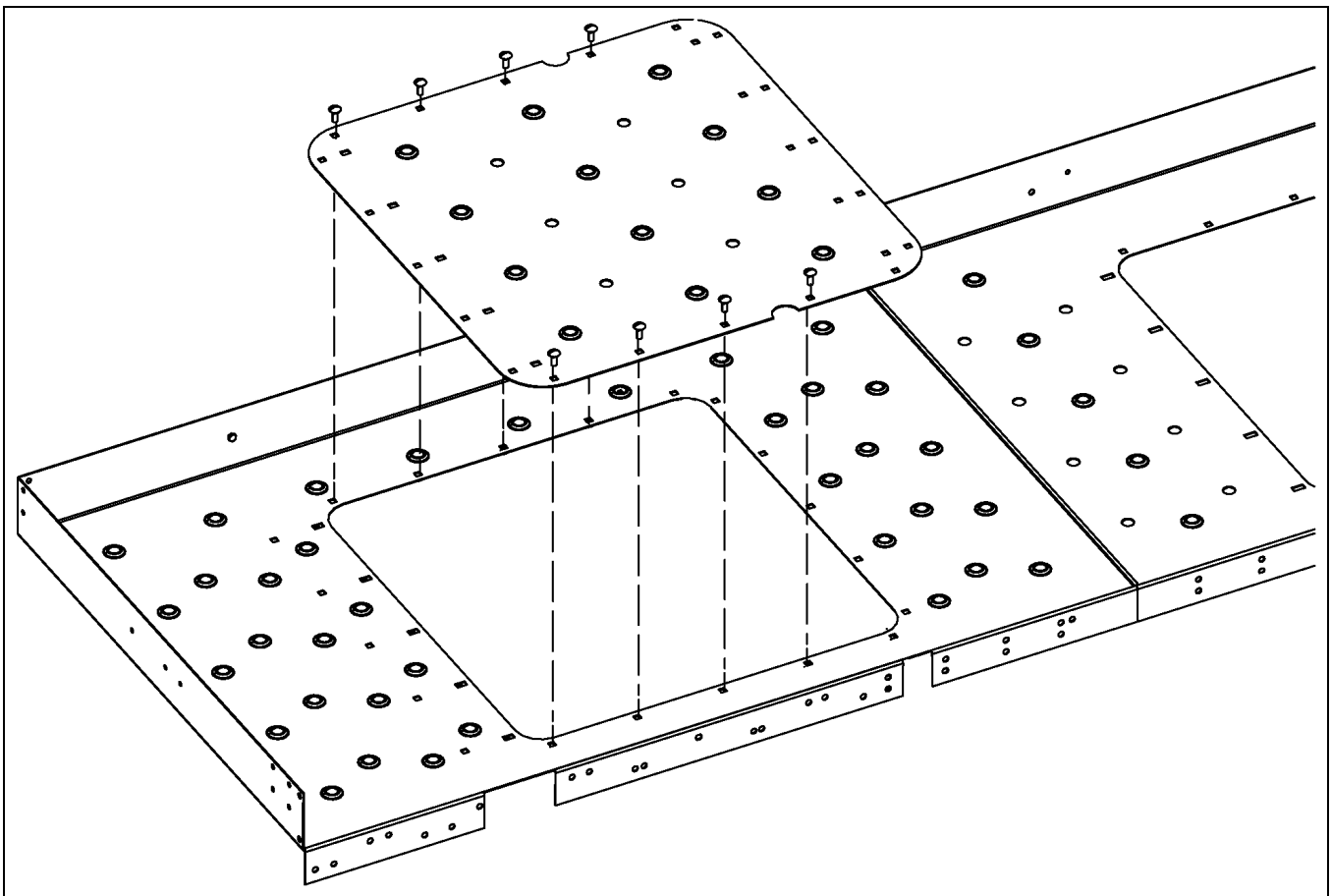

Figure 8F Hatch at Up-Leg End

Slide/Place Toe Boards on Cross Deck Support Channels

NOTE: Due to the snug fit, you should slide the toe boards in place before placing and securing Deck A or any subsequent decking.

1. On the non-drive side slide one toe board (HP36STBX) into place.
2. On the drive side slide one toe board (HP36STBX) into place. (See Figure 8G.)

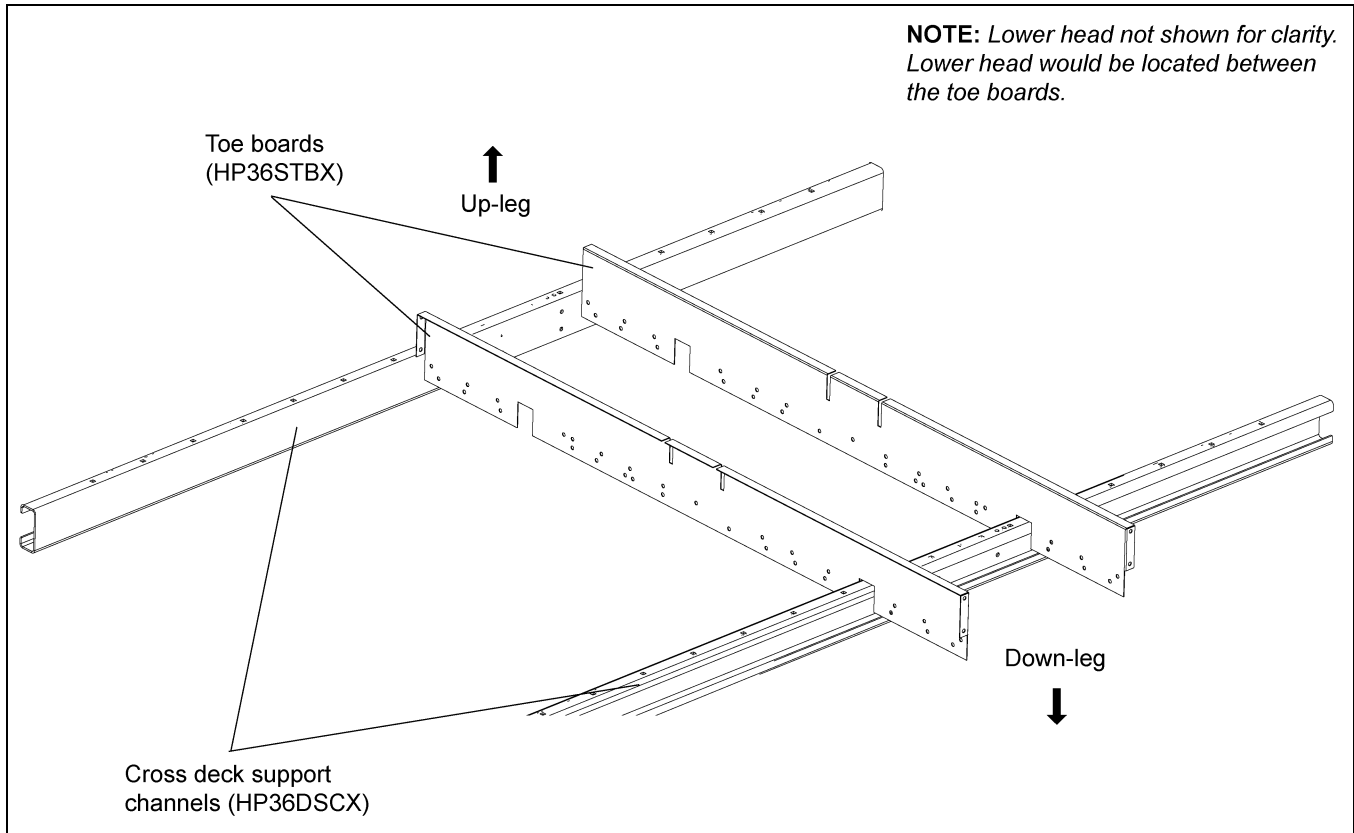

Figure 8G

8. 30"-36" Head Platform Right Hand Drive

Connect Deck A to Cross Deck Support Channels and Toe Board

NOTE: Orientation of etched holes on deck and channel is critical to subsequent steps. Connect all bolts only finger tight until deck is completely assembled and then tighten to proper torque.

1. Locate pre-assembled Deck A. This plank consists of the hatch opening and the hatch cover plate.
2. Orient Deck A so the hatch opening is at discharge end of lower head and hatch cover plate is at up-leg end.
3. At the **Discharge End**, use a punch as needed to line up. (See Figure 8H.)
 - a. For 36" - Deck hole **A1** and channel hole **X1**.
 - b. For 36" - Deck hole **A7** to channel hole **X2**.
 - c. For 30" - Deck hole **A1** and channel hole **Y1**.
 - d. For 30" - Deck hole **A7** to channel hole **Y2**.
 - e. For both 30" and 36" - Deck hole **A2** to toe board hole **A2**. (See Figure 8I on Page 53.)

NOTE: At this time, the head platform hatch deck support (HP36HDS) should be installed **UNDER** Deck A. Line this up with hole **A12** on the deck flange near hatch opening and install at the same time attaching deck to toe board. (See Figure 8I on Page 53.)

4. At the **Up-Leg End** for both 30" and 36", use a punch to align:
 - a. Channel hole **Y1** to corner hole of hatch cover plate.
 - b. Deck hole **A4** to toe board hole **A4**. (See Figure 8I on Page 53.)
5. Connect holes as described above, connect all holes between support channel and Deck A.

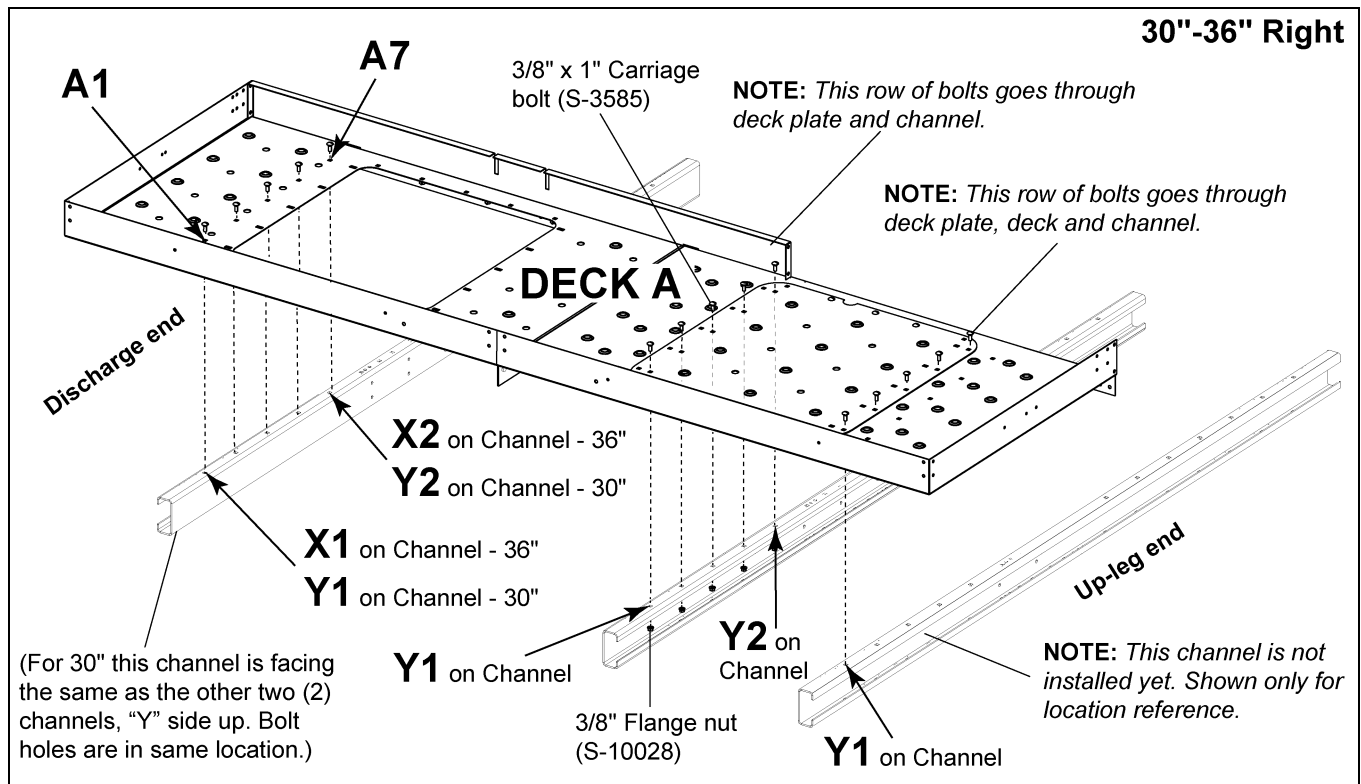

Figure 8H

8. 30"-36" Head Platform Right Hand Drive

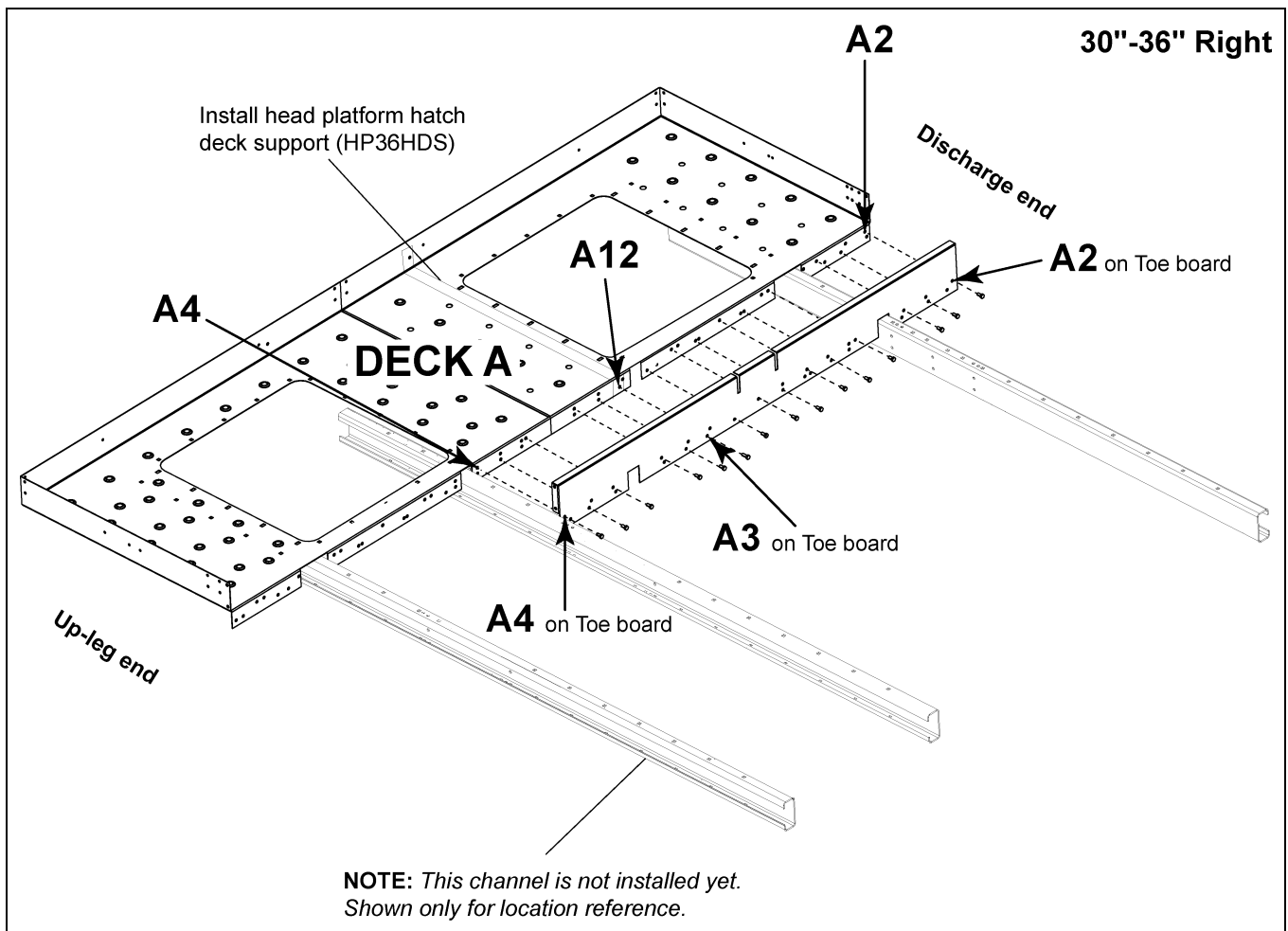

Figure 8I

8. 30"-36" Head Platform Right Hand Drive

Connect Deck C to Cross Deck Support Channel and to Toe Board

NOTE: The orientation of the flanges on Deck C is critical to subsequent steps. Tighten bolts only finger tight until deck alignment is complete.

1. Locate the pre-assembled Deck C. This deck consists of two (2) planks.
2. Orient Deck C with hole **C3** at the discharge end of the lower head.
3. Make sure the extended kick plate flange of Deck C is away from the lower head assembly. (See Figure 8J below and Figure 8K on Page 55.)
4. Align holes. Use a punch as needed to line up the holes:
 - a. For 36" - Deck hole **C3** and channel hole **X5** at discharge end.
 - b. For 30" - Deck hole **C3** and channel hole **Y5** at discharge end.
5. Connect cross deck support channel and Deck C using 3/8" x 1" carriage bolts (S-3585) with flange nuts (S-10028). Connect all holes between channel and deck. (See Figure 8J.)
6. Align and connect Deck C to toe board using 3/8" x 1" bolts (S-7469) with flange nuts (S-10028).
 - a. Deck hole **C1** to toe board hole **A4**.
 - b. Deck hole **C2** to toe board hole **A2**.

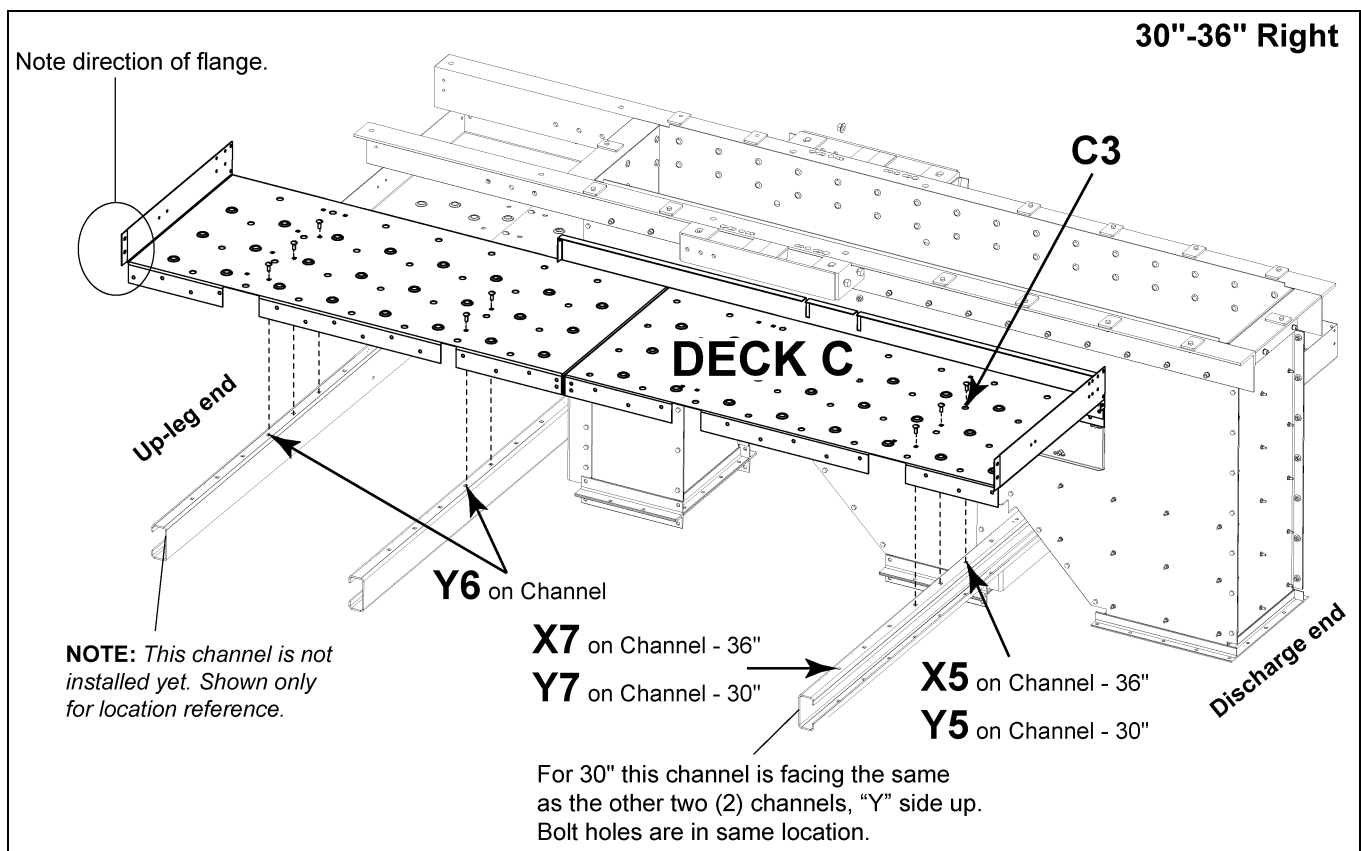

Figure 8J Deck C to Cross Deck Support Channels

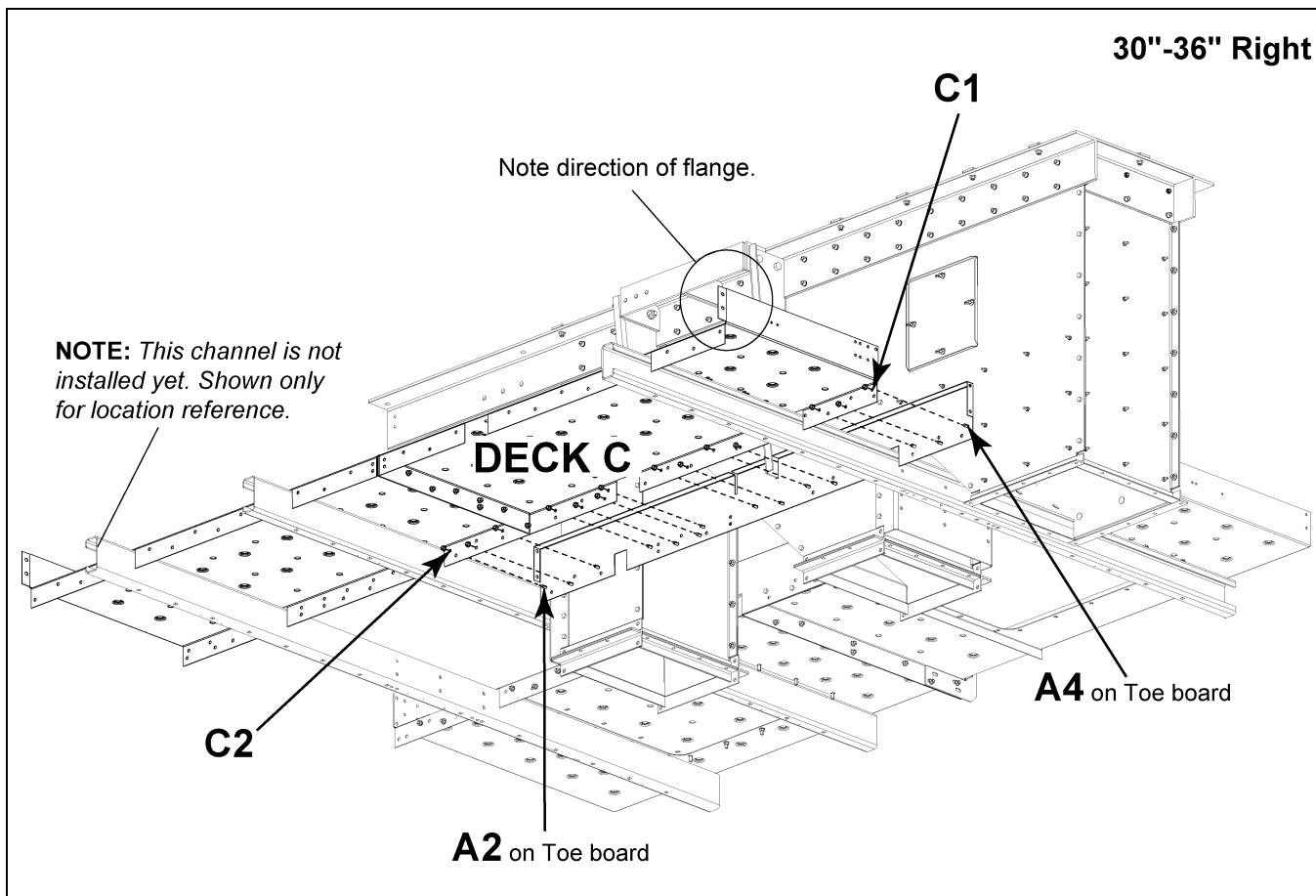

Figure 8K Underside View of Deck C to Toe Board

8. 30"-36" Head Platform Right Hand Drive

Connect Deck F to Cross Deck Support Channels and Deck C

IMPORTANT: *Connect all bolts only finger tight until deck is completely assembled and then tighten to proper torque.*

1. Locate pre-assembled Deck F. This deck consists of two (2) planks.
2. Orient Deck F with hole **F3** at the discharge end of the lower head and **F5** at the up-leg end. *(See Figure 8L.)*
3. Align holes. Use a punch as needed to line up the holes:
 - a. **For 36"** - Deck hole **F3** and channel hole **X7**.
 - b. **For 30"** - Deck hole **F3** and channel hole **Y7**.
 - c. **For 30" and 36"** - Deck hole **F5** and channel hole **Y7**.
4. Connect deck to channel using 3/8" x 1" carriage bolts (S-3585) with flange nuts (S-10028).
5. Orient Deck F flange outside of Deck C flange. *(See Figure 8N on Page 57.)*

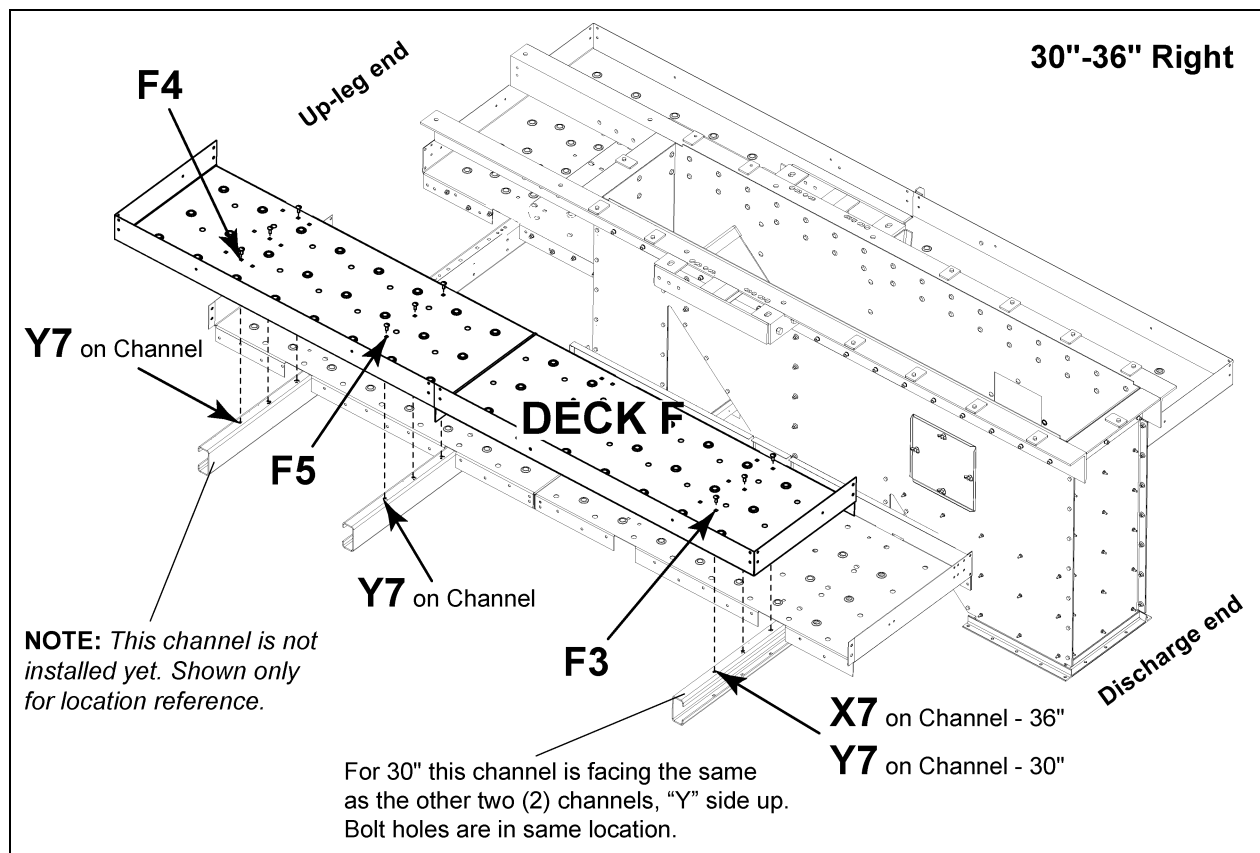

Figure 8L Deck F to Cross Deck Support Channel

8. 30"-36" Head Platform Right Hand Drive

6. Connect Deck F to Deck C using 3/8" x 1" bolts (S-7469) with flange nuts (S-10028).
 - a. Align F Deck hole **F2** to C deck hole **C6**.
 - b. Align F Deck hole **F1** to C deck hole **C7**. (See Figure 8M.)

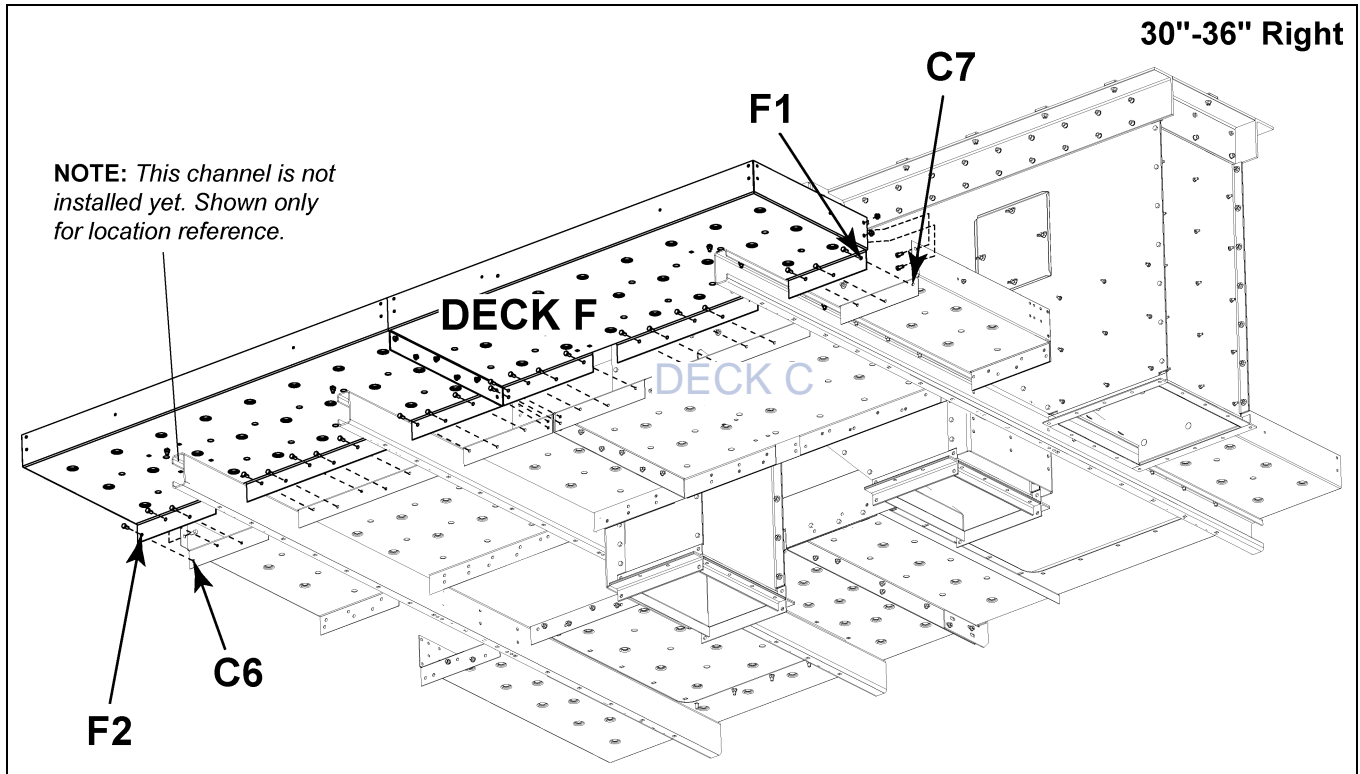

Figure 8M Deck F to Deck C

7. Install the head platform hatch deck support (HP1648HDS) under Deck C and Deck F using 3/8" x 3/4" bolt (S-7105) and nut. (See Figure 8N.) **NOTE:** You may need to remove a bolt from the toe board if one was installed in this location.

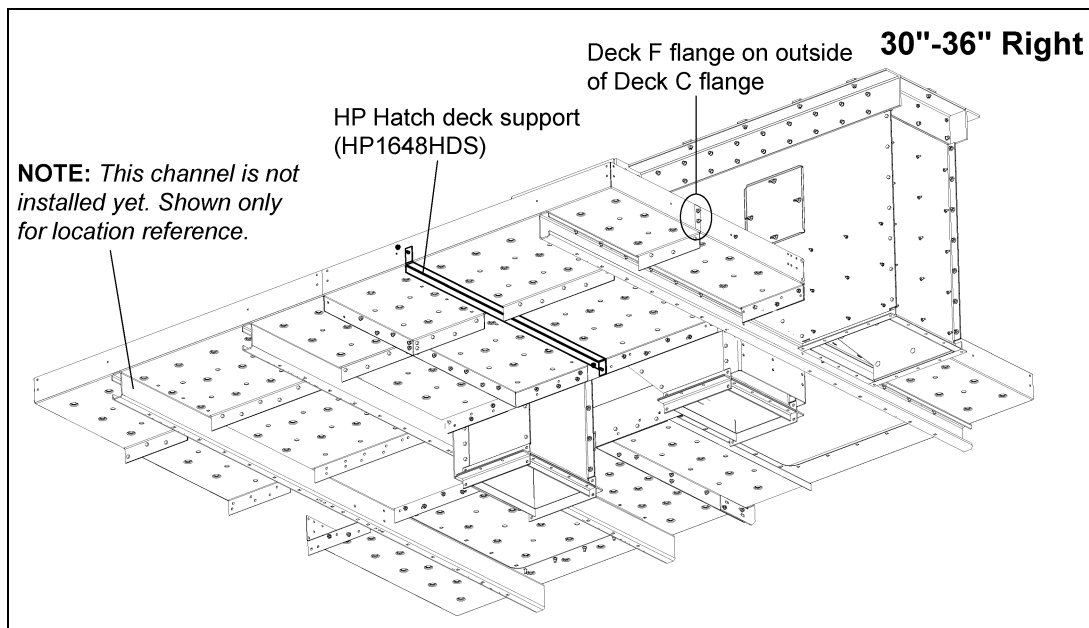

Figure 8N

8. 30"-36" Head Platform Right Hand Drive

Attach Third Cross Deck Support Channel to Decking

Connect all bolts only finger tight until deck is completely assembled and then tighten to proper torque.

1. Orient channel: Locate the third cross deck support channel (HP36DSCX) and orient it so the "Y" side faces up and hole **Y1** is on the non-drive side of the lower head assembly.
2. Align holes. Use a punch as needed to line up the holes accordingly:
 - a. At the **drive side** - channel hole **Y7** on the cross deck support channel to deck hole **F4**. (See Figure 8L on Page 56.)
 - b. At the **hatch side** - channel hole **Y1** on the cross deck support channel to Deck A and deck plate cover. (See Figure 8H on Page 52.)
 - c. Connect Deck F to support channels using 3/8" x 1" carriage bolts (S-3585) with flange nuts (S-10028). Connect all holes between channel and deck.

Attach Deck E to Deck A, Deck C and Cross Deck Support Channel

NOTE: Connect all bolts only finger tight until deck is completely assembled and then tighten to proper torque.

1. Place Deck E between Deck A and Deck C. (See Figure 80.)
2. Align holes. Use a punch as needed to align deck holes **E5** with channel hole **Y4**. This will align Deck E with holes on each channel.
3. Connect Deck E to cross deck support channels using 3/8" x 1" carriage bolts (S-3585) with flange nuts (S-10028). Connect all holes between channels and deck.
4. Connect the Deck E kick plate flanges to toe boards and flanges of Deck A and Deck C using 3/8" x 3/4" bolts (S-7105) and 3/8" nuts (S-10028). (See Figure 80.)

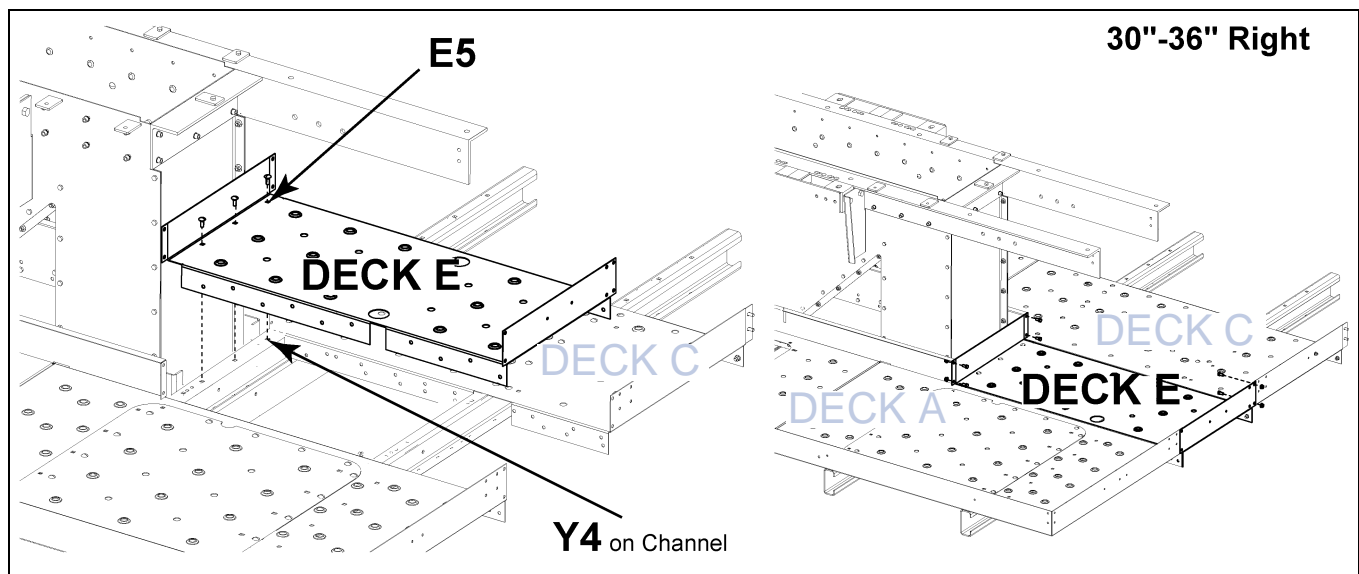

Figure 80

8. 30"-36" Head Platform Right Hand Drive

5. Connect Deck E to Deck A and Deck C using 3/8" x 3/4" bolts (S-7105) with flange nuts (S-10028).
(See Figure 8P.)
 - a. A Deck hole **A5** to E deck hole **E1**.
 - b. A Deck hole **A6** to E deck hole **E2**.
 - c. C Deck hole **C5** to E deck hole **E3**.
 - d. C Deck hole **C4** to E deck hole **E4**.



After decking is completely assembled, make sure to go back and tighten all bolts and nuts to the proper torque rating.

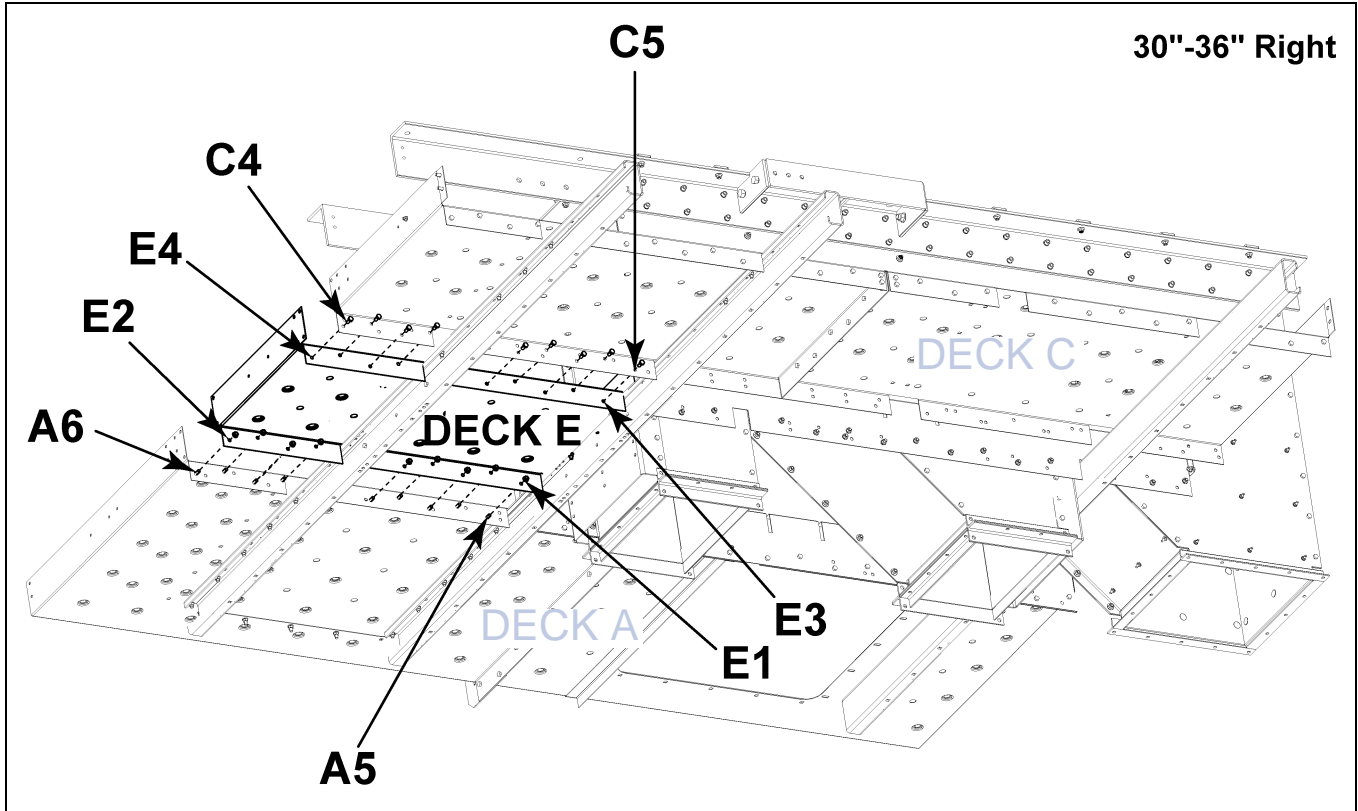

Figure 8P

Chapter 9: 30"-36" Head Platform Left Hand Drive

To facilitate quick and easy assembly, numerous parts are pre-assembled prior to shipping.

Considerable time is dedicated at the beginning of this manual to the proper orientation of channels and decks. This is because the orientation of these elements is essential to the proper construction of the head platform.

1. There are many ways to get the orientation wrong and only one way to get it right.
2. Proper orientation of the channels and decks is essential proper assembly.
3. Proper construction of the head platform can only be completed if the initial orientation of the channels is done correctly.

Therefore, we strongly advise you take time to confirm that the orientation of these early elements is correct before you begin to assemble the decking on to the channels.

To facilitate proper connections, major connecting holes are etched with alpha-numeric codes.

- One side is labeled **X1** through **X7**, this side is referred to as the “**X**” side.
- The opposite side is labeled with **Y1** through **Y7** and is referred to as the “**Y**” side.

Attach Cross Deck Support Channels to Lower Head

Three (3) cross deck support channels support the platform. Two (2) of the channels are attached to brackets on the lower head section and the third channel is attached to the decking itself but is not attached directly to the lower head. This third channel will be attached after the deck is assembled. (See Figure 9A.)

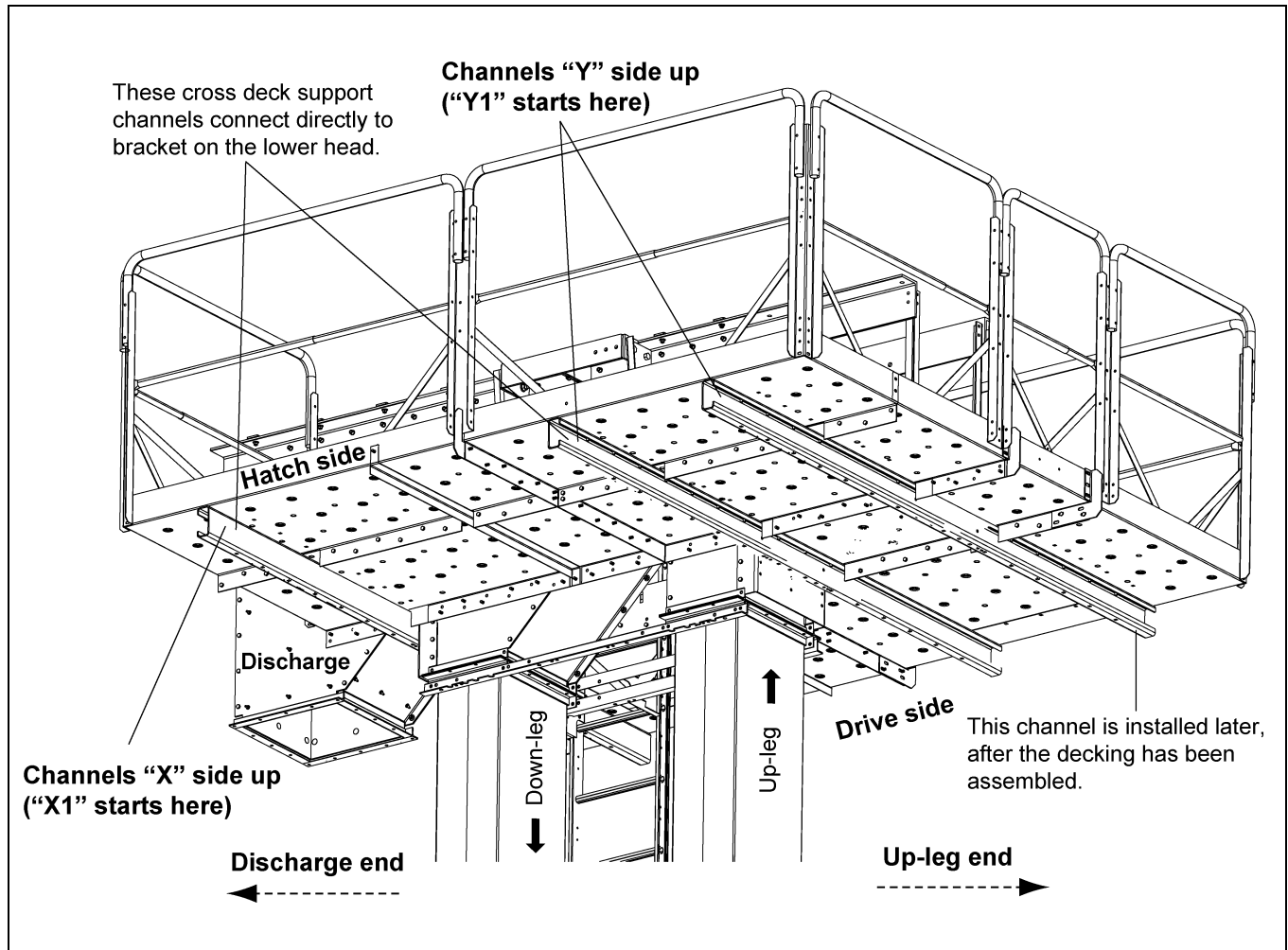

Figure 9A Left Platform Overview

NOTE: The difference between left and right. The only difference is the channel orientation as they attach to the lower head brackets. This makes you swap Deck A with the positions of Deck C and Deck F.

For 30" Left Side Drive

Orient the Channel

1. At **Discharge End** orient the channel so that:
 - a. Channel opening is outward, toward the discharge end of the head.
 - b. Holes labeled with "X" face up.
 - c. Hole **X1** is on the non-drive side of the lower head.
 - d. Hole **X7** is on the drive side of the lower head.
 - e. Cross deck support channel extends farther on the drive side than on hatch side of lower head.
 2. At **Up-Leg End** orient the channel so that:
 - a. Channel opening outward, toward the up-leg end of the head.
 - b. Holes labeled with "X" face up.
 - c. Hole **X1** is on the non-drive side of the lower head.
 - d. Hole **X7** is on the drive side of the lower head.
 - e. Cross deck support channel extends farther on the drive side than on hatch side of lower head.
(See [Figure 9B on Page 63.](#))
 3. Attach cross deck support channels (HP36DSCX) to the top-most set of holes of the lower head brackets (HSP36130) using 3/8" x 1" bolts and nuts. (See [Figure 9C on Page 63.](#))
- *NOTE:** *The channels MUST be oriented as shown in [Figure 9B and Figure 9C on Page 63](#) in order for the decking and subsequent assembly to be done correctly.*

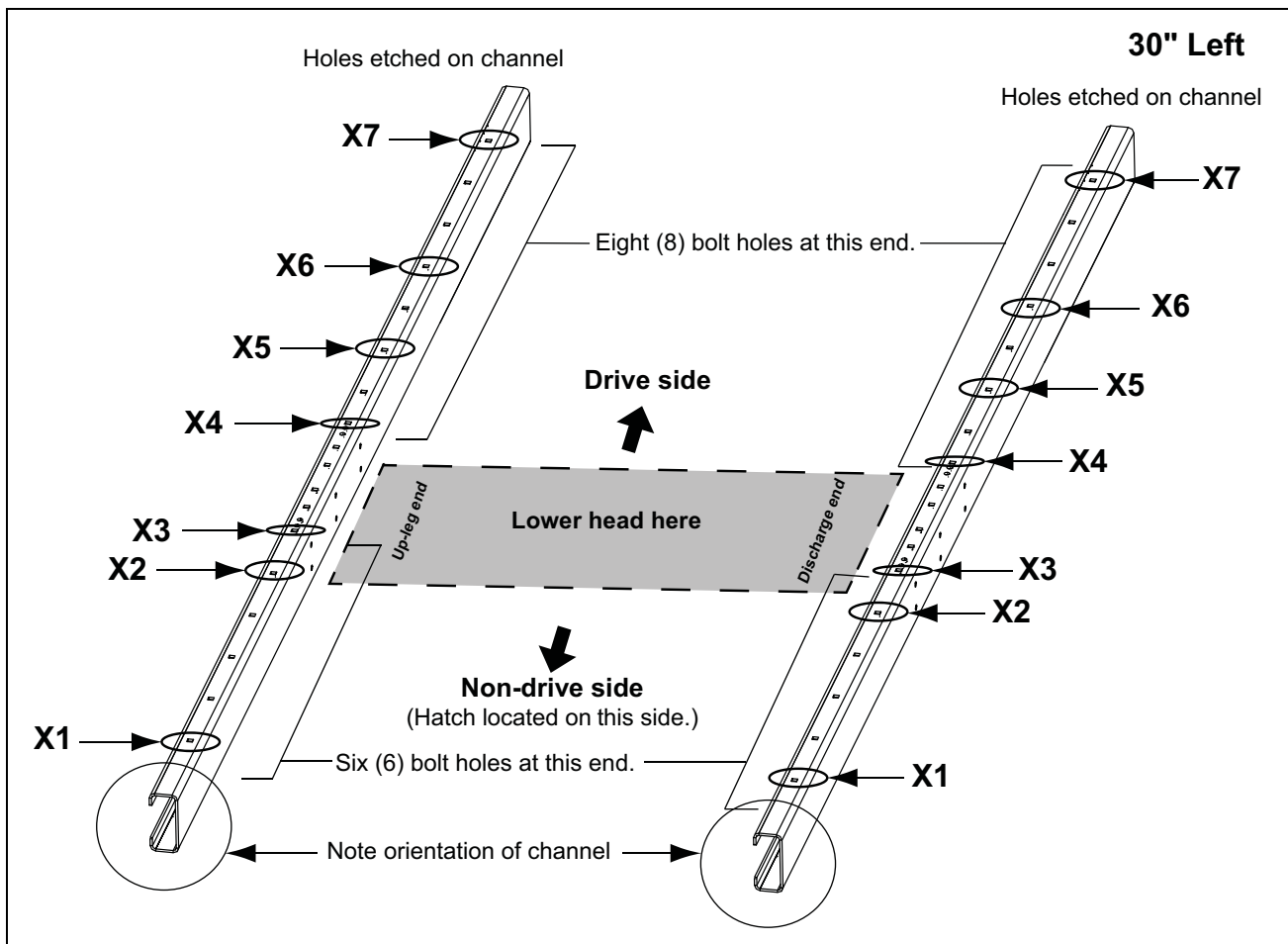

Figure 9B 30" Left Side Drive Channel Position

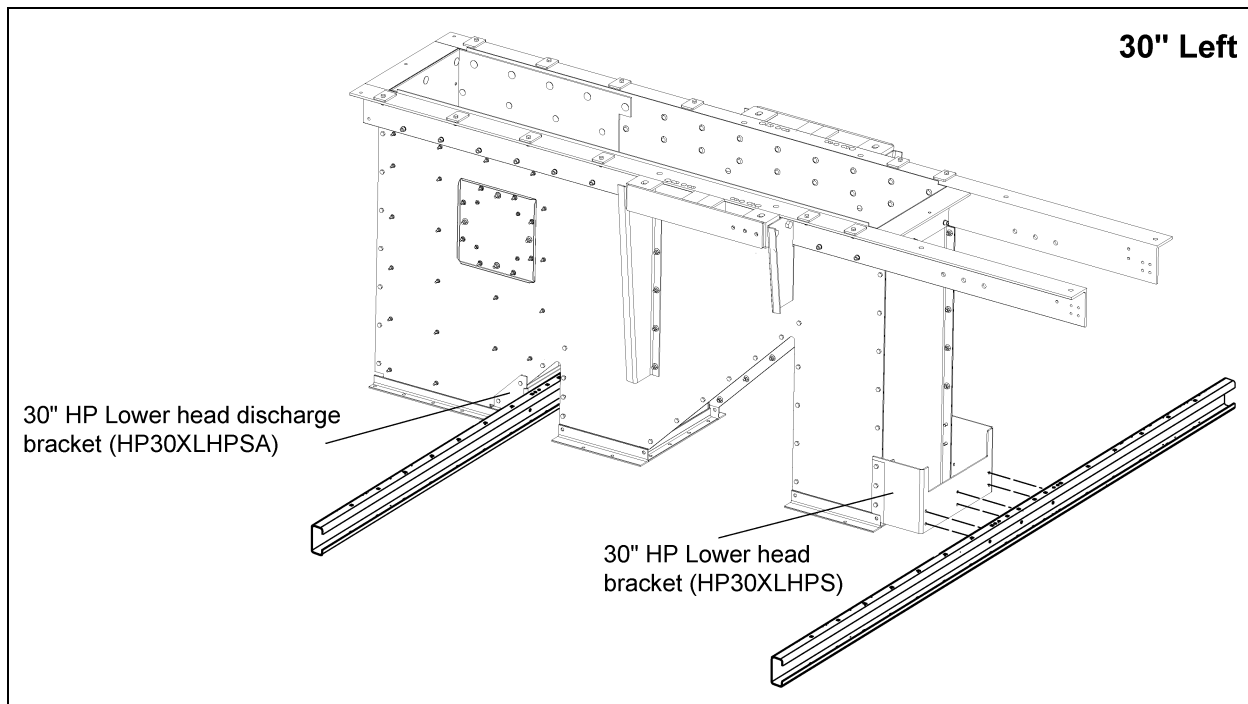

Figure 9C 30" Left Drive - Cross Deck Support Channels to Lower Head Brackets

For 36" Left Side Drive

Orient the Channel

1. At **Discharge End** orient the channel so that:
 - a. Channel opening is outward, toward the discharge end of the head.
 - b. Holes labeled with “Y” face up.
 - c. Hole **Y1** is on the non-drive side of the lower head.
 - d. Hole **Y7** is on the drive side of the lower head.
 - e. Cross deck support channel extends farther on the drive side than on hatch side of lower head.
 2. At **Up-Leg End** orient the channel so that:
 - a. Channel opening outward, toward the up-leg end of the head.
 - b. Holes labeled with “X” face up.
 - c. Hole **X1** is on the non-drive side of the lower head.
 - d. Hole **X7** is on the drive side of the lower head.
 - e. Cross deck support channel extends farther on the drive side than on hatch side of lower head.
(See Figure 9D on Page 65.)
 3. Attach cross deck support channels (HP36DSCX) to the top most set of holes of the lower head brackets (HSP36130) using 3/8" x 1" bolts and nuts. *(See Figure 9E on Page 65.)*
- *NOTE:** *The channels MUST be oriented as shown in Figure 9D and Figure 9E on Page 65 in order for the decking and subsequent assembly to be done correctly.*

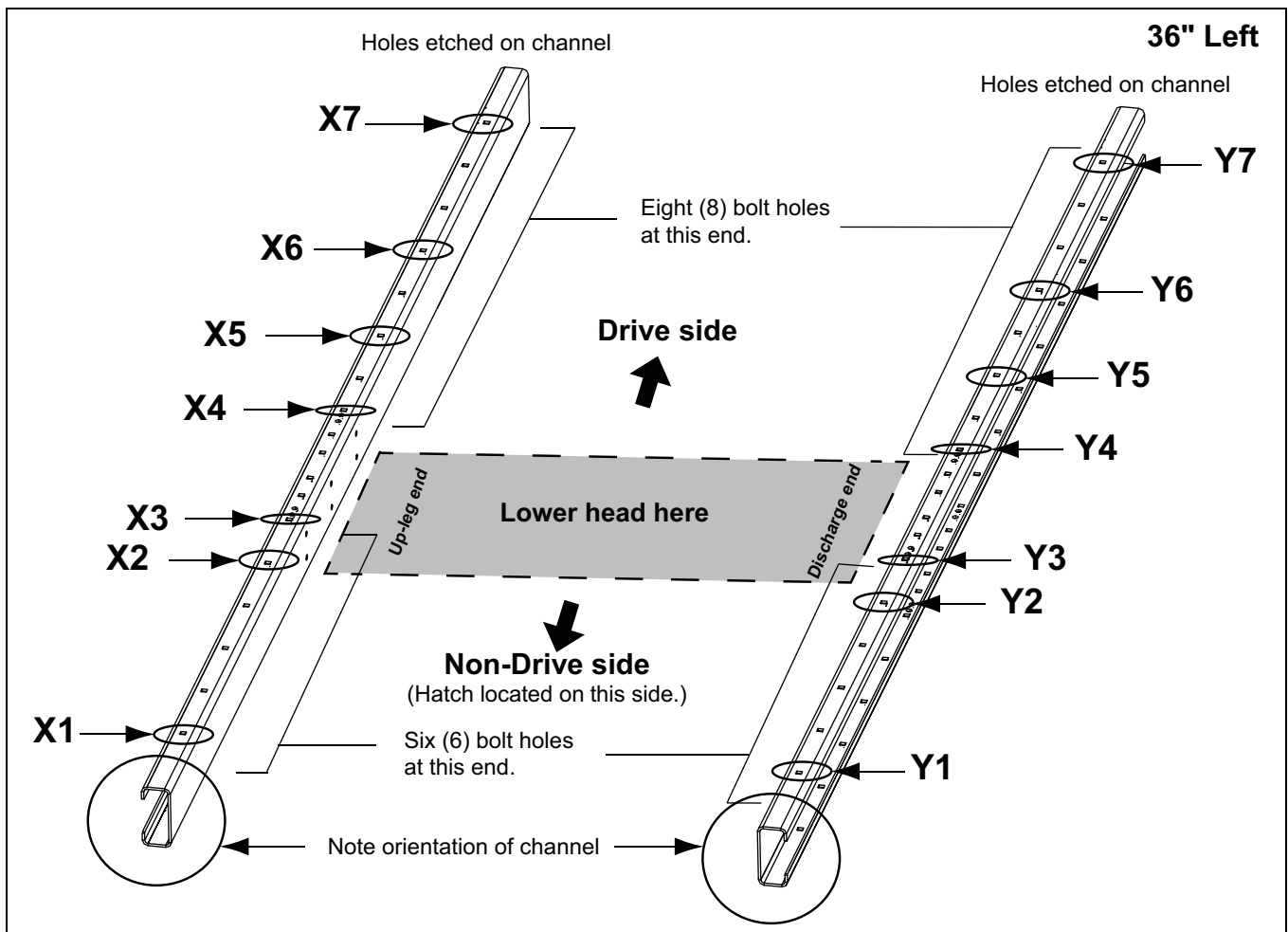

Figure 9D 36" Left Side Drive Channel Position

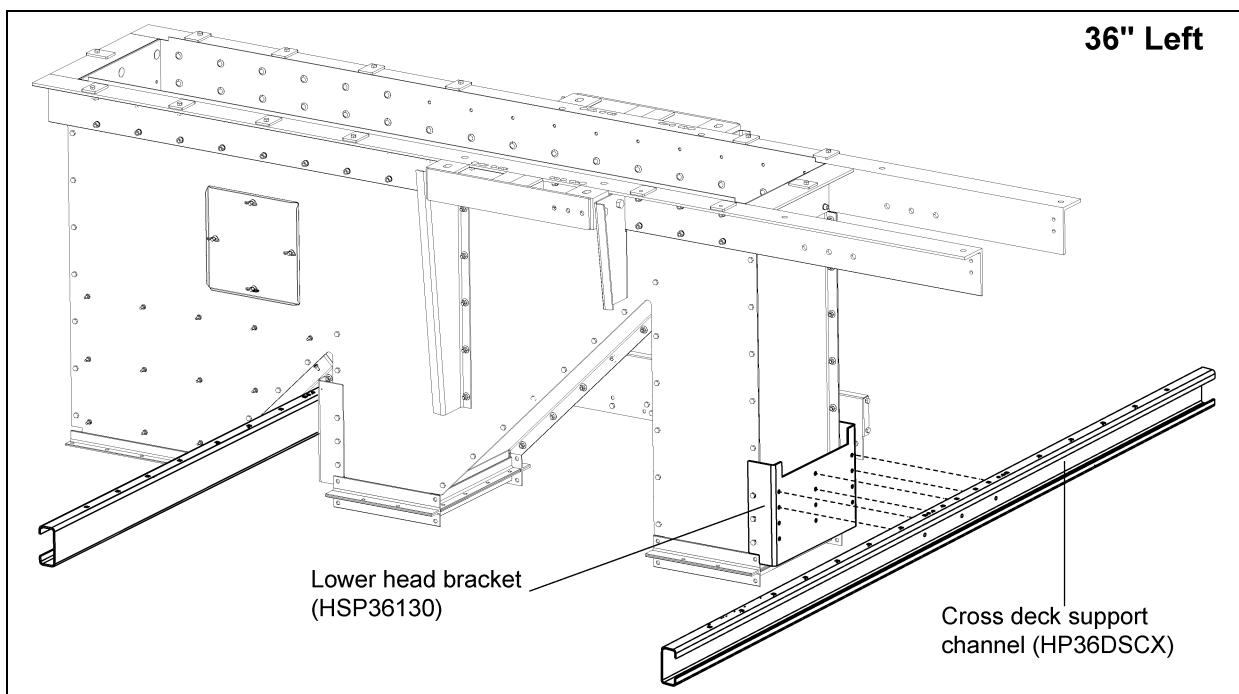

Figure 9E

Attach Deck A to Hatch Cover Plate

NOTE: Only two (2) side of deck plate are attached at this time.

1. **Locate pre-assembled Deck A:** This plank consists of the hatch opening, the hatch filler plate and is labeled with holes etched with the letter A.
2. **Orient Deck A:** The hatch cover plate is at the up-leg end of the deck. The hatch will be located at the discharge end and will remain open at this time. A hatch door will be attached to Deck A later and should NOT be installed at this time
3. **Attach the hatch cover plate to Deck A:** Use eight (8) 3/8" x 1" carriage bolts (S-3585) with flange nuts (S-10028). (See Figure 9F.)

NOTE: ONLY connect the hatch filler plate along two (2) of the four (4) sides of the plate. The holes perpendicular to the length of Deck A should remain open at this time as they will serve to connect the hatch cover plate and deck A to the cross deck support channel.

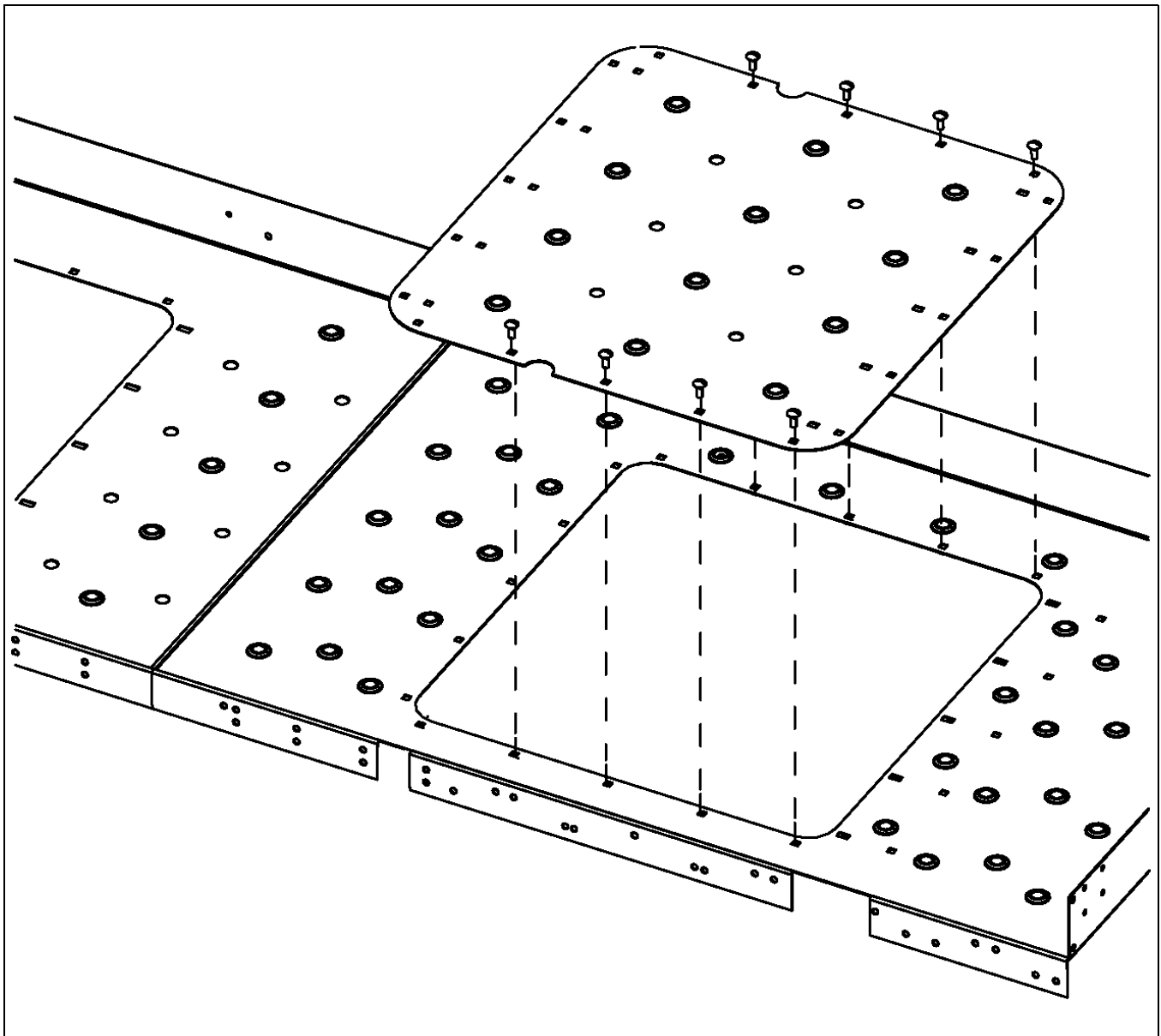

Figure 9F Hatch at Up-Leg End

Slide/Place Toe Boards on Cross Deck Support Channels

NOTE: Due to the snug fit, you should slide the toe boards in place before placing and securing Deck A or any subsequent decking.

1. On the non-drive side slide one toe board (HP36STBX) into place.
2. On the drive side slide one toe board (HP36STBX) into place. (See Figure 9G.)

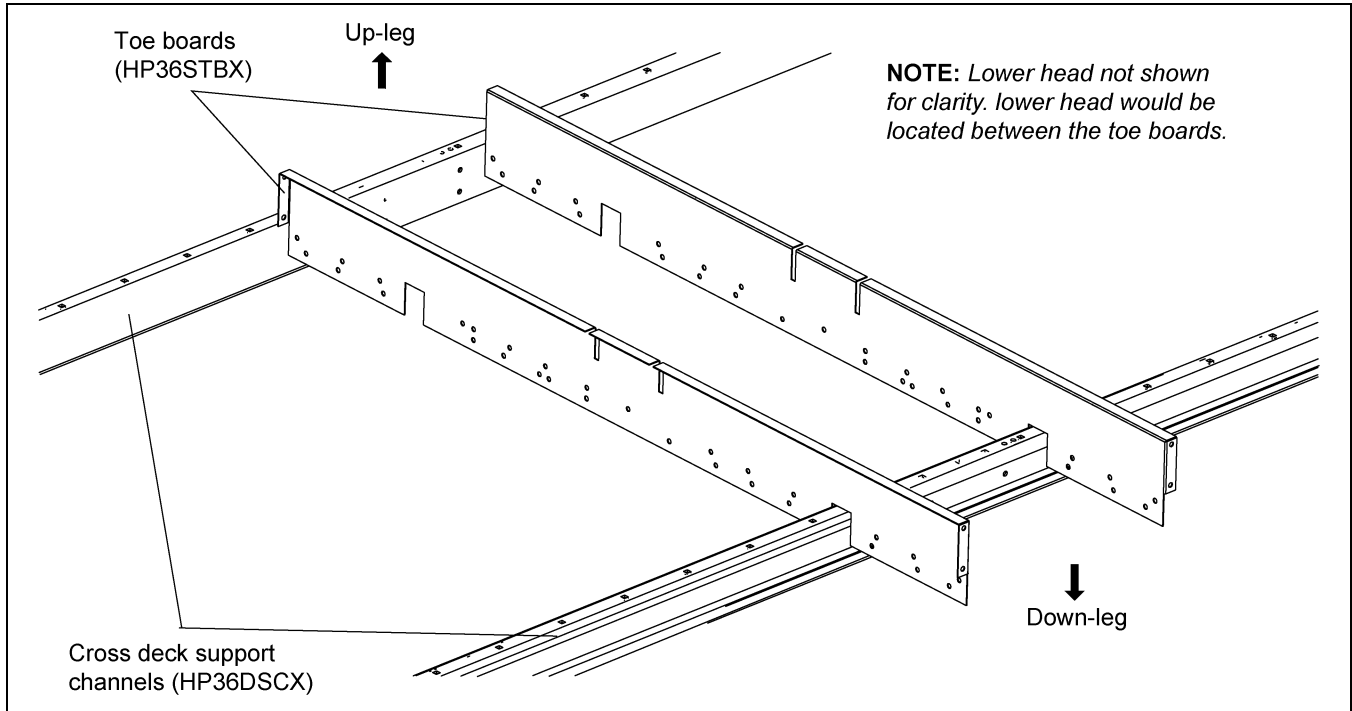

Figure 9G

9. 30"-36" Head Platform Left Hand Drive

Connect Deck A to Cross Deck Support Channels and Toe Board

NOTE: Orientation of etched holes on deck and channel is critical to subsequent steps. Tighten bolts only finger tight until all decking is installed.

1. Locate pre-assembled Deck A. This plank consists of the hatch opening and the hatch cover plate.
2. Orient deck a so that hatch opening is at discharge end of lower head and hatch cover plate is at the up-leg end.
3. On the **Discharge End**, use a punch as needed to line up. (See Figure 9H.)
 - a. **For 36"** - Deck hole **A9** and channel hole **Y2**.
 - b. **For 30"** - Deck hole **A9** to channel hole **X2**.

NOTE: At this time, the head platform hatch deck support (HP36HDS) should be installed **UNDER** Deck A. Line this up with hole **A4** on the deck flange near hatch opening and install at the same time attaching deck to toe board. (See Figure 9I on Page 69.)

4. On the **Up-Leg End** for both **36"** and **30"**, use a punch to align channel hole **X1** to corner hole of hatch cover plate.
5. After aligning the holes as described above, connect all holes between support channel and Deck A using 3/8" x 1" carriage bolts (S-3585) with flange nuts (S-10028).

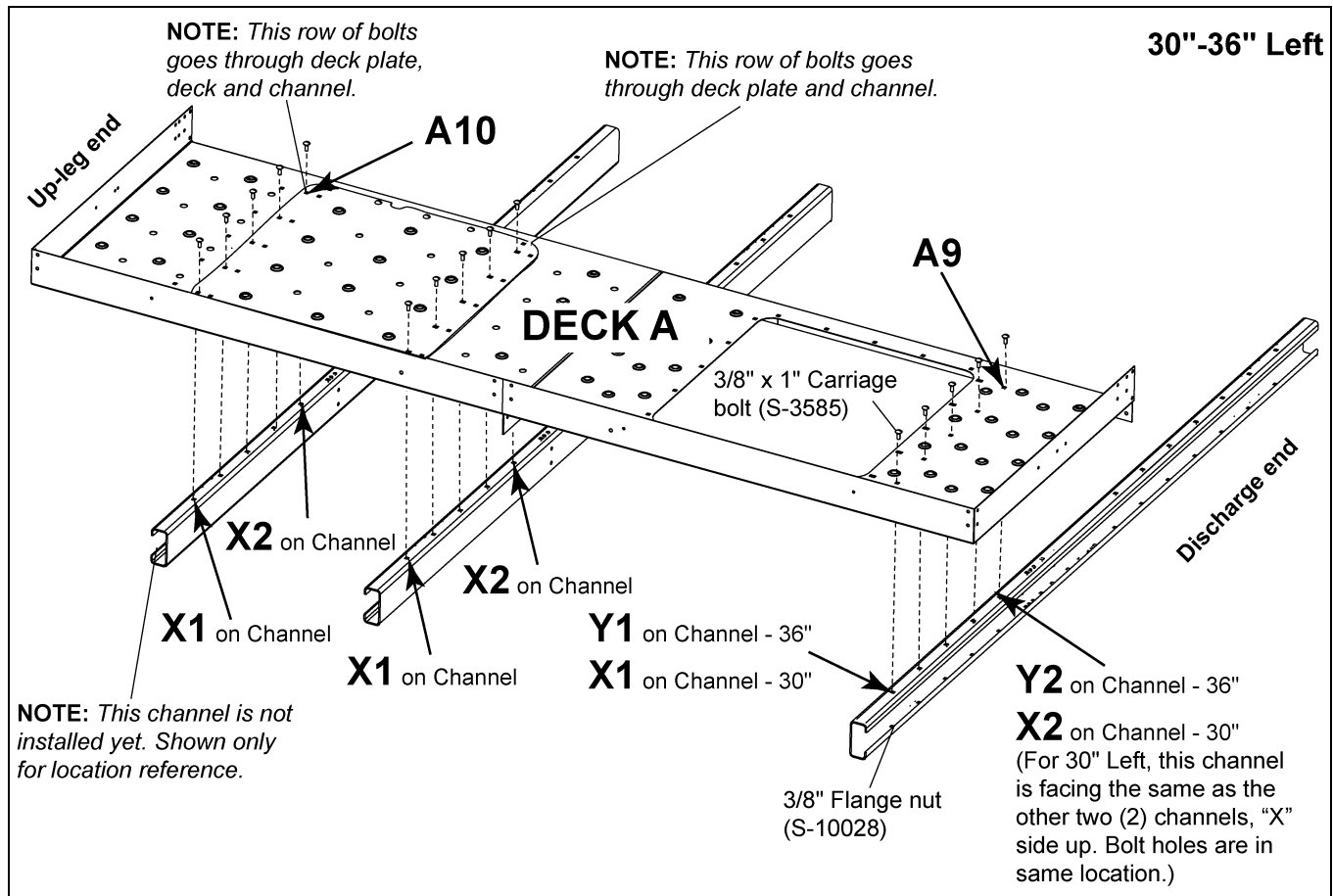

Figure 9H

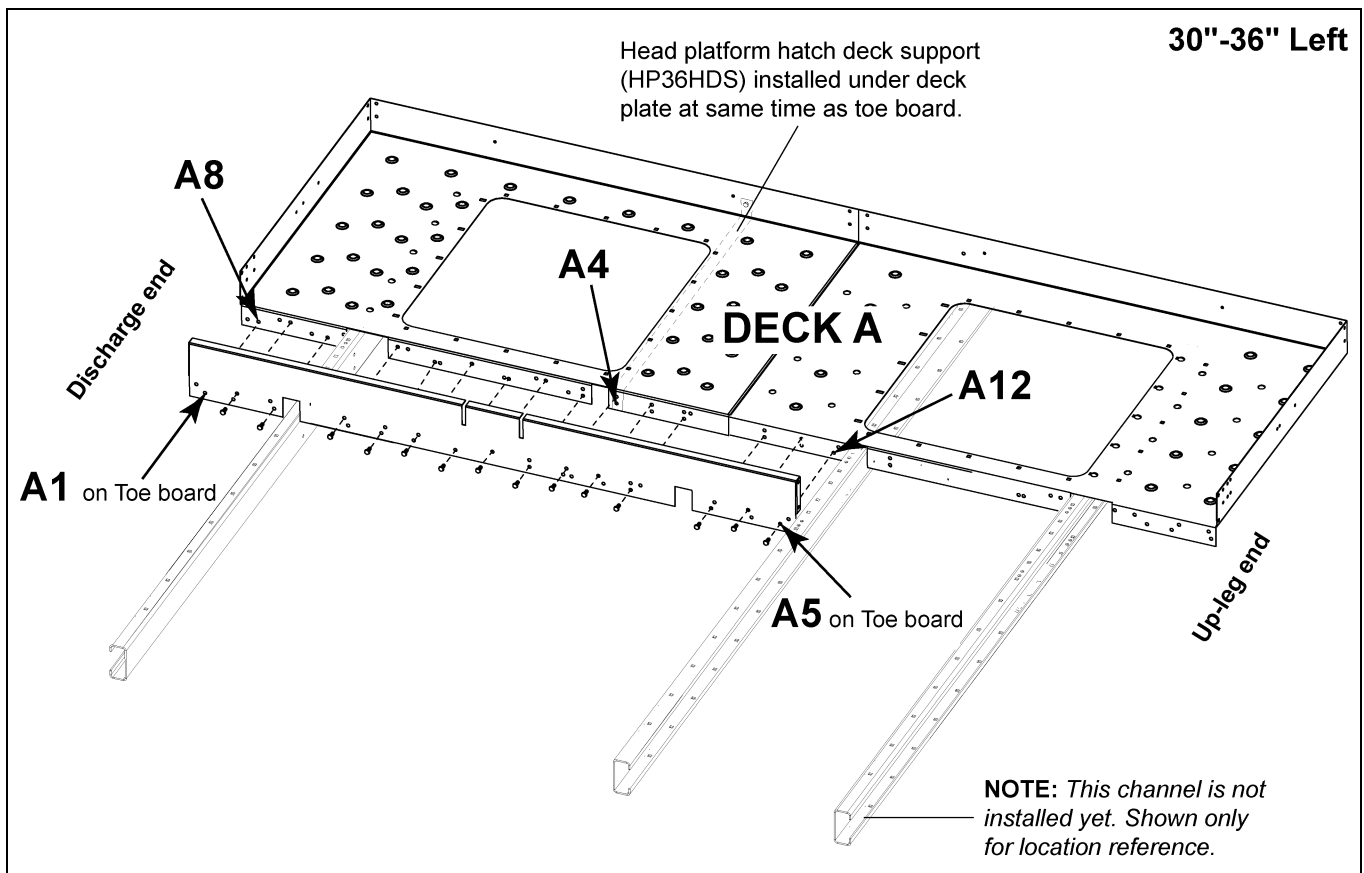

Figure 9I

6. **Connect Deck A to Toe Board:** Line up holes on toe board with holes on Deck A:

- a. Deck hole **A8** and toe board hole **A1**.
- b. Deck hole **A12** to toe board hole **A5**.

Connect Deck C to Cross Deck Support Channel and to Toe Board

NOTE: The orientation of the flanges on Deck C is critical to subsequent steps. Tighten bolts only finger tight until deck alignment is complete.

1. Locate the pre-assembled Deck C. This deck consists of two (2) planks.
2. Orient Deck C with hole **C10** at the discharge end of the lower head.
3. Make sure the extended kick plate flange of Deck C is away from the lower head assembly. *(See Figure 9J and Figure 9K on Page 70.)*
4. On the **Discharge End**, use a punch as needed to line up holes:
 - a. **For 36"** - Deck hole **C10** and channel hole **Y6**.
 - b. **For 30"** - Deck hole **C10** to channel hole **X6**.

NOTE: The only difference between the 30" and 36" is the channel on the discharge end would be flipped so the opening of channel is the same as the other two (2) channels for 30".

5. Connect cross deck support channel and deck C using 3/8" x 1" carriage bolts (S-3585) with flange nuts (S-10028). Connect all holes between channel and deck.

9. 30"-36" Head Platform Left Hand Drive

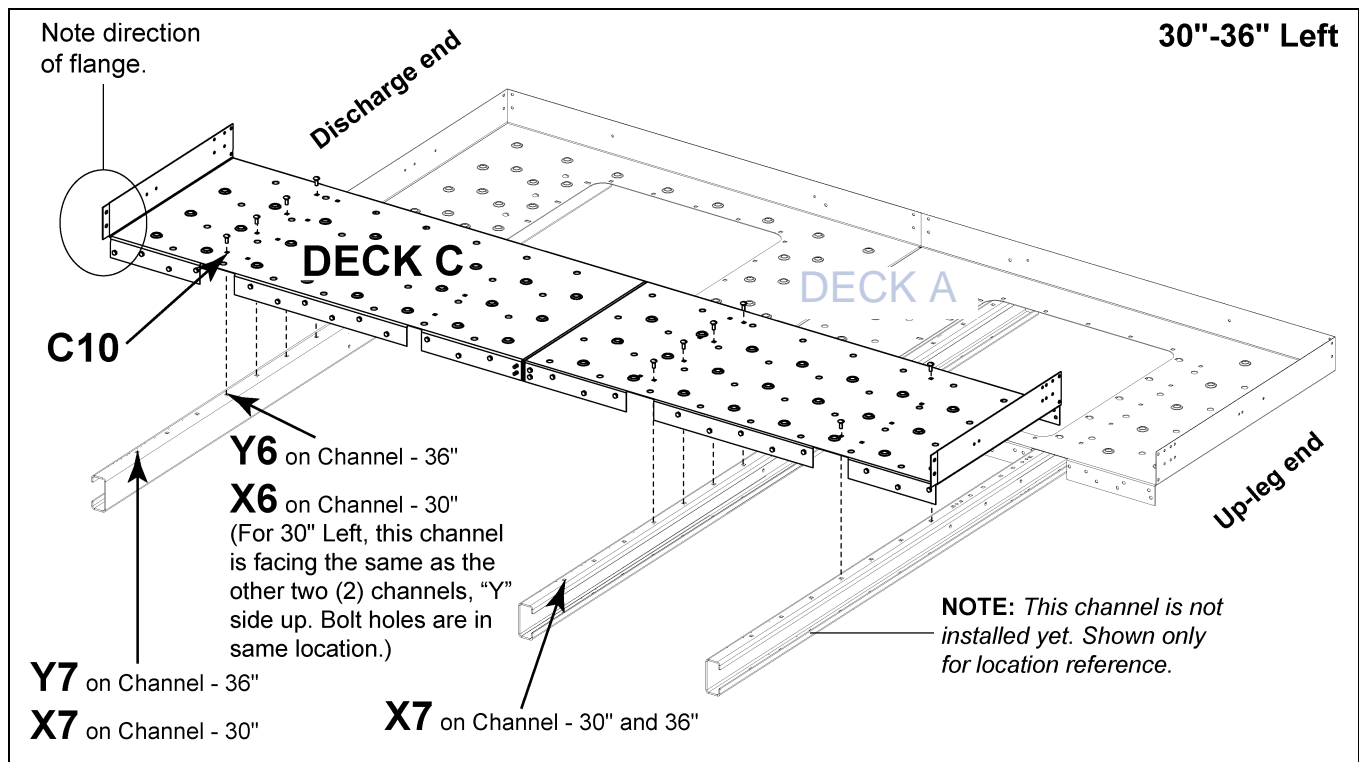

Figure 9J Deck C to Cross Deck Support Channels

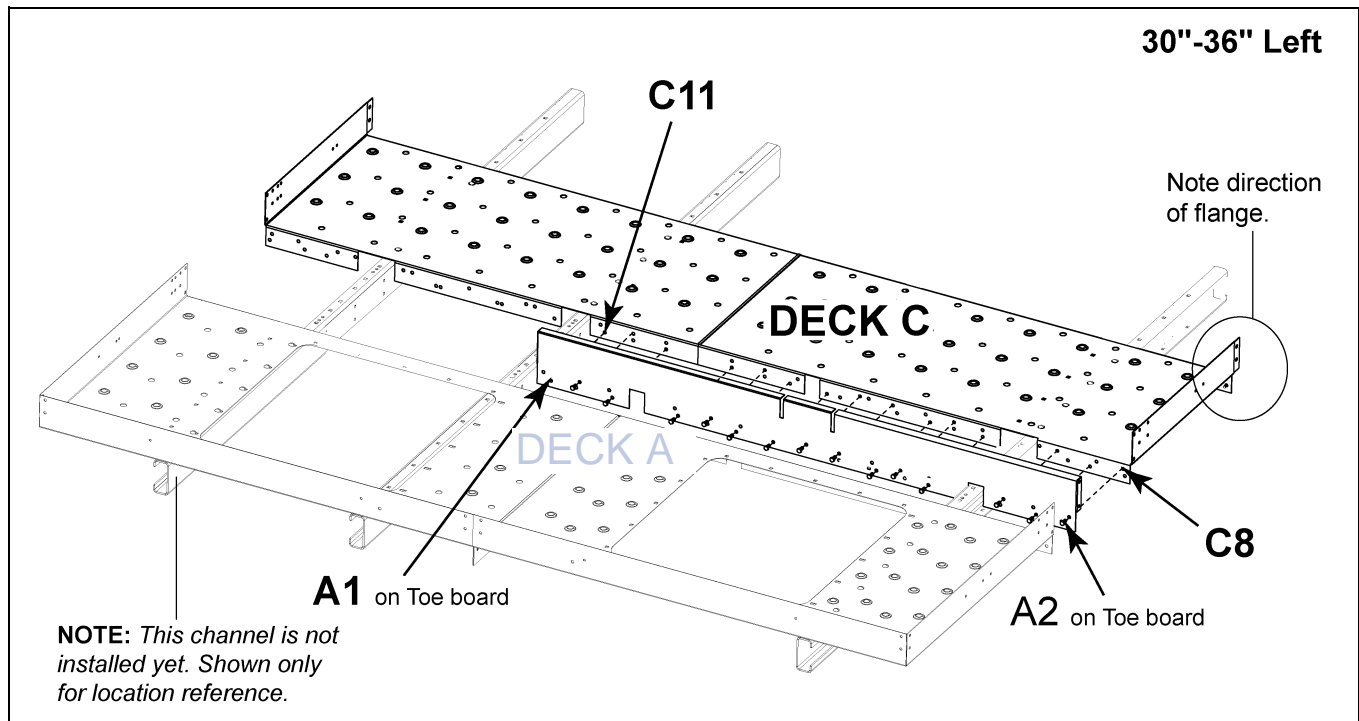

Figure 9K Underside View of Deck C to Toe Board

6. Connect Deck C to toe board using 3/8" x 1" bolts (S-7469) with flange nuts (S-10028).
 - a. Deck hole **C11** to toe board hole **A1**.
 - b. Deck hole **C8** to toe board hole **A2**.

Connect Deck F to Cross Deck Support Channels and Deck C

IMPORTANT: Connect all bolts only finger tight until deck is completely assembled and then tighten to proper torque.

1. Locate pre-assembled Deck F. This deck consists of two (2) planks.
2. Orient Deck F with hole **F7** at the discharge end of the lower head and **F6** at the up-leg end. (See Figure 9L.)
3. Align holes. Use a punch as needed to line up the holes:
 - a. Deck hole **F6** and channel hole **X7**.
 - b. Deck hole **F7** and channel hole **Y7**.
4. Connect deck to channel using 3/8" x 1" carriage bolts (S-3585) with flange nuts (S-10028).
5. Orient Deck F flange outside of Deck C flange. (See Figure 9M on Page 72.)
6. Align and connect Deck F to Deck C using 3/8" x 1" bolts (S-7469) with flange nuts (S-10028).
 - a. F Deck hole **F2** to C deck hole **C6**.
 - b. F Deck hole **F1** to C deck hole **C7**. (See Figure 9L.)

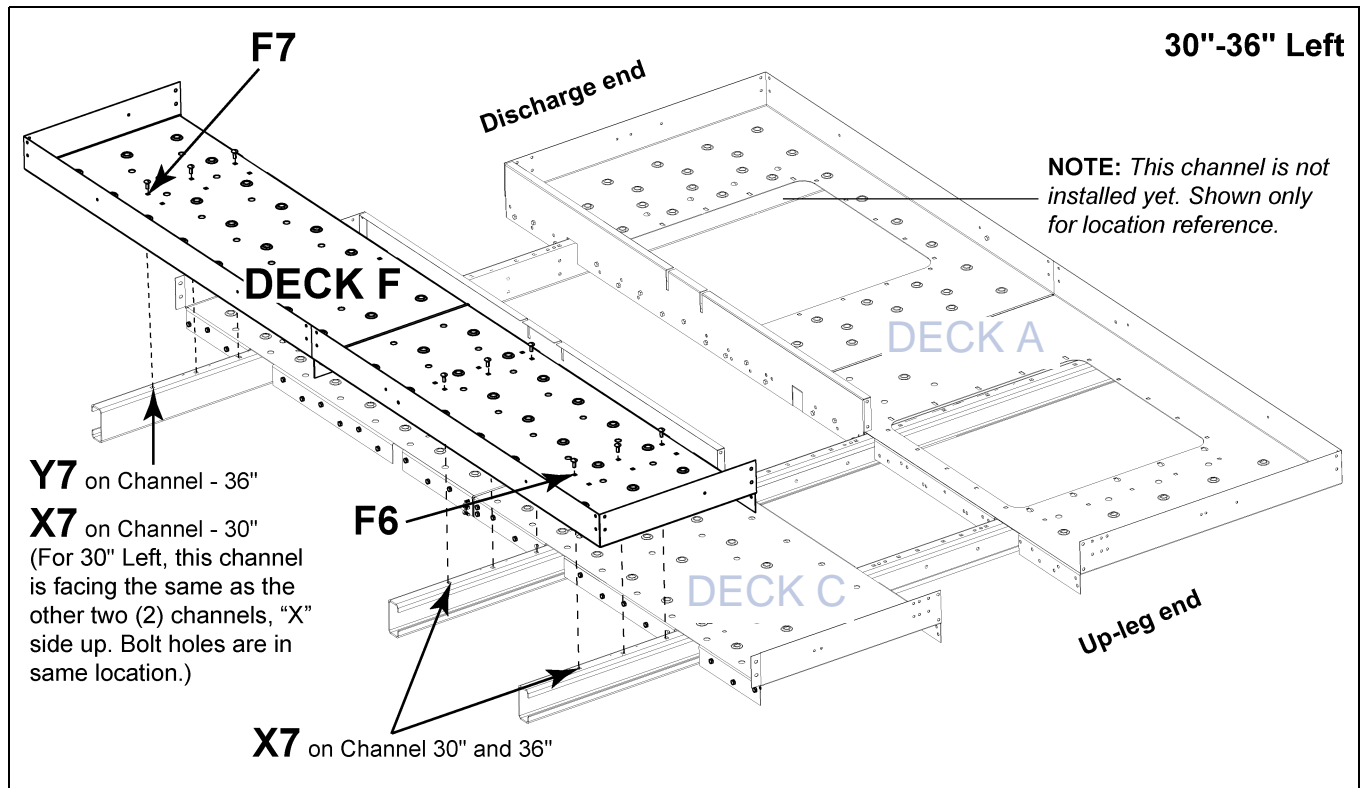

Figure 9L Deck F to Cross Deck Support Channel

9. 30"-36" Head Platform Left Hand Drive

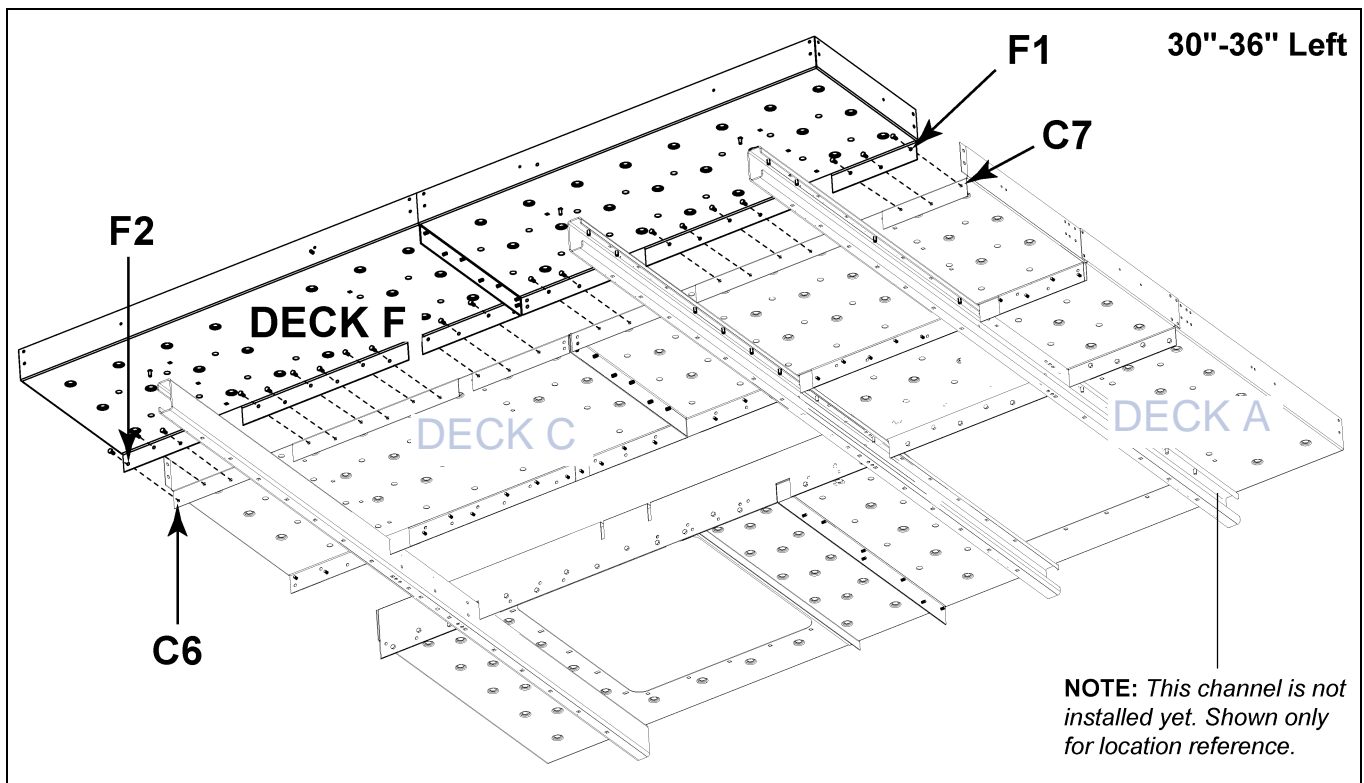

Figure 9M Deck F to Deck C

7. Install the head platform hatch deck support (HP1648HDS) under Deck C and Deck F using 3/8" x 3/4" bolt (S-7105) and nut. (See Figure 9N.) **NOTE:** You may need to remove a bolt from the toe board if one was installed in this location.

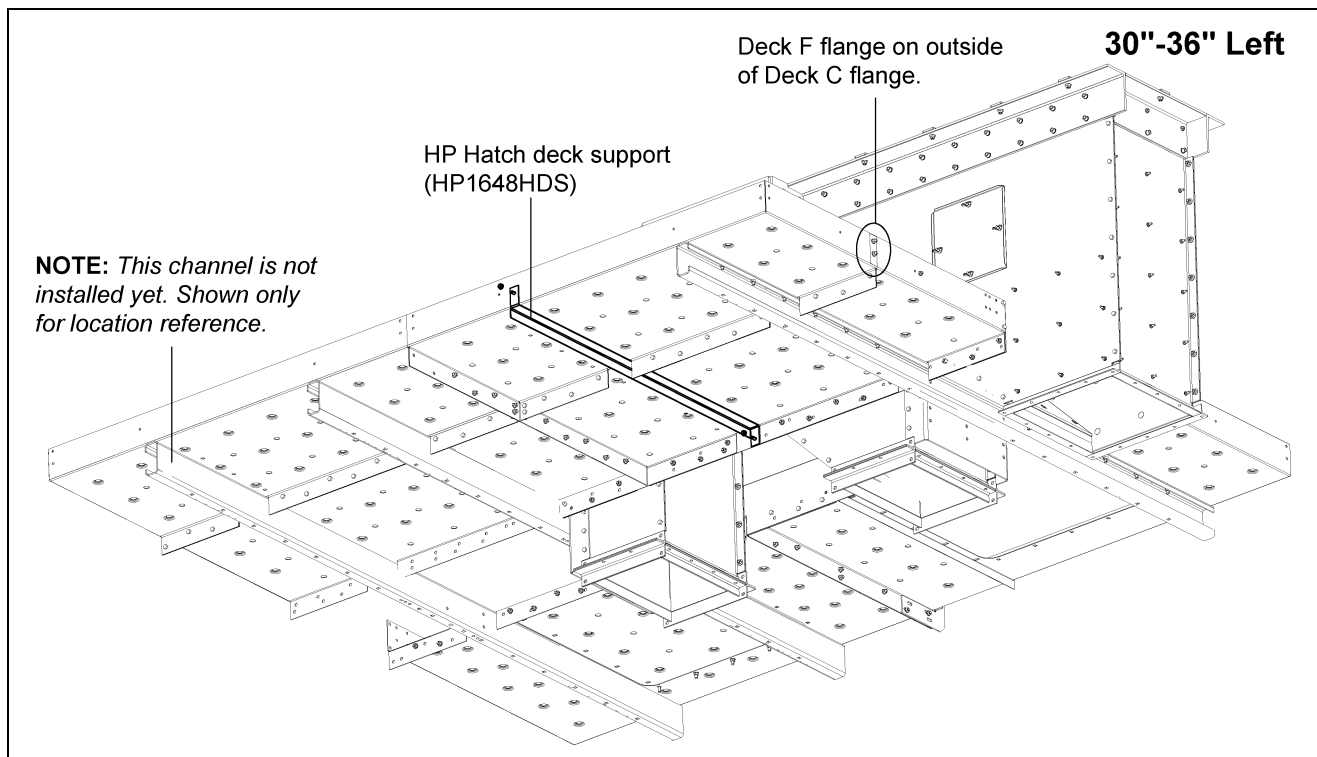

Figure 9N

Attach Third Cross Deck Support Channel to Decking

NOTE: Connect all bolts only finger tight until deck is completely assembled and then tighten to proper torque.

1. Locate the third (3rd) cross deck support channel (HP36DSCX) and orient it so the X side faces up and hole X1 is on the non-drive side of the lower head assembly.
2. Align holes. Use a punch as needed to align holes accordingly:
 - a. At the **drive side** - Channel hole **X7** on the cross deck support channel to Deck F hole **F6**.
(See Figure 9L on Page 71.)
 - b. At the **hatch side** - Channel hole **X2** on the cross deck support channel to Deck A hole **A10** and deck plate cover. (See Figure 9H on Page 68.)
 - c. Connect Deck F to support channels using 3/8" x 1" carriage bolts (S-3585) with flange nuts (S-10028). Connect all holes between channel and deck.

Attach Deck E to Deck A, Deck C and Cross Deck Support Channel

NOTE: Connect all bolts only finger tight until deck is completely assembled and then tighten to proper torque.

1. Position Deck E between Deck A and Deck C. Note that Deck E will be connected to two (2) channels. (See Figure 9P on Page 74.)
2. Align holes. Use a punch as needed to align deck holes **E5** with channel hole **X3**. This will align Deck E with holes on each channel. (See Figure 9O on Page 74.)
3. Connect Deck E to cross deck support channels using 3/8" x 1" carriage bolts (S-3585) with flange nuts (S-10028). Connect all holes between channels and deck.
4. Connect the Deck E kick plate flanges to toe boards and flanges of Deck A and Deck C using 3/8" x 3/4" bolts (S-7105) and 3/8" nuts (S-10028). (See Figure 9P on Page 74.)
5. Align and connect Deck E to Deck A and Deck C using 3/8" x 1" bolts (S-7469) with flange nuts (S-10028). (See Figure 9P on Page 74.)
 - a. C Deck hole **C12** to E deck hole **E1**.
 - b. C Deck hole **C9** to E deck hole **E2**.
 - c. A Deck hole **A13** to E deck hole **E3**.
 - d. A Deck hole **A11** to E deck hole **E4**.

9. 30"-36" Head Platform Left Hand Drive

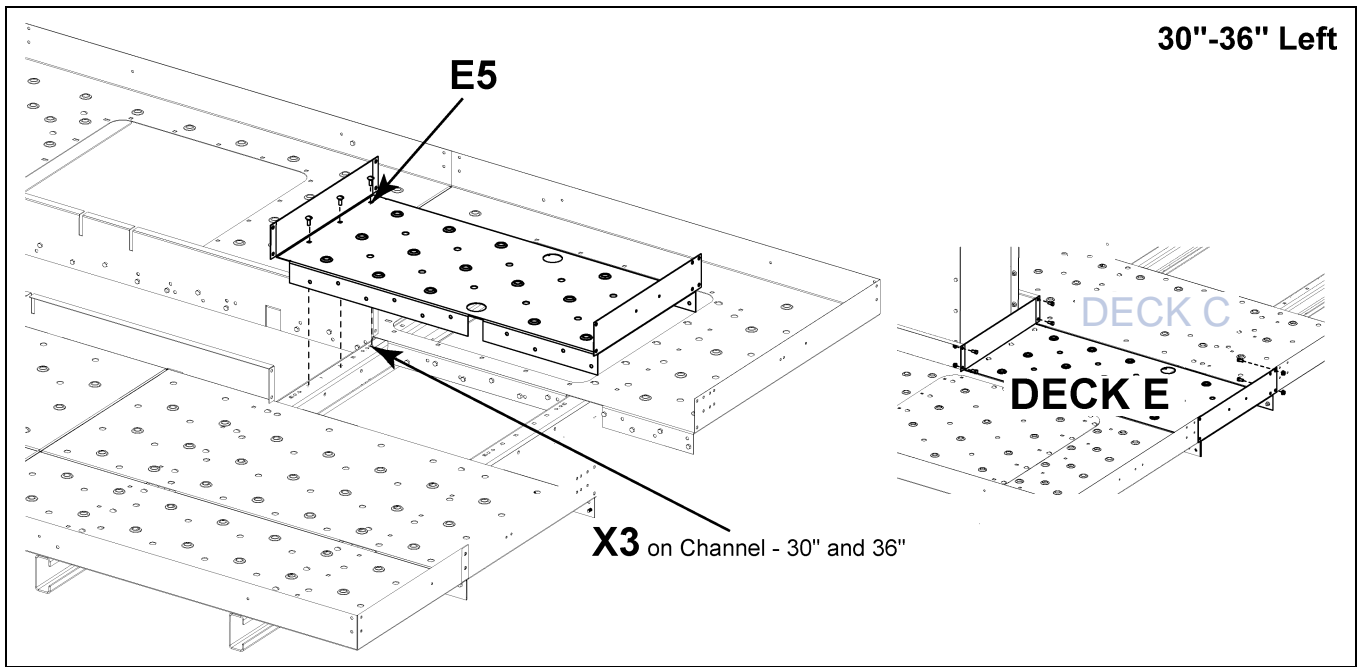

Figure 90



After decking is completely assembled, make sure to go back and tighten all bolts and nuts to the proper torque rating.

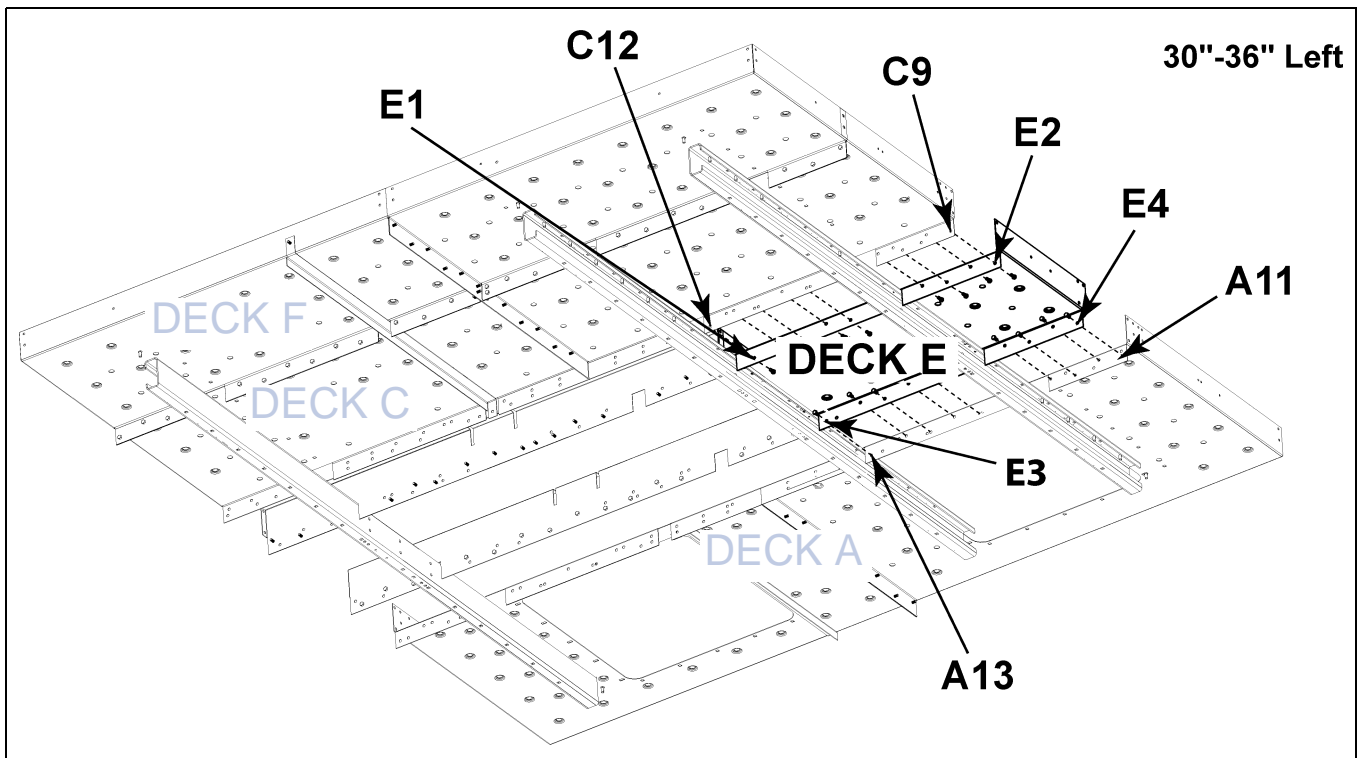

Figure 9P

Chapter 10: 30"-36" Head Platform Post, Rails and Bracing

The following assemblies occur the same on all 30"-36" platform installations, regardless of left or right drive orientation.

Attach Head Bearing Support Angle to Lower Head for 30"

1. Connect two (2) HP head bearing support brackets (HP30HBE) as shown to the lower head using 3/8" x 1" bolts (S-7469) and nuts.
2. Attach two (2) head bearing angle supports (HP30HBS) to the head bearing support brackets and cross deck support channels with 3/8" x 1" bolts (S-7469) and nuts. *(See Figure 10A.)*

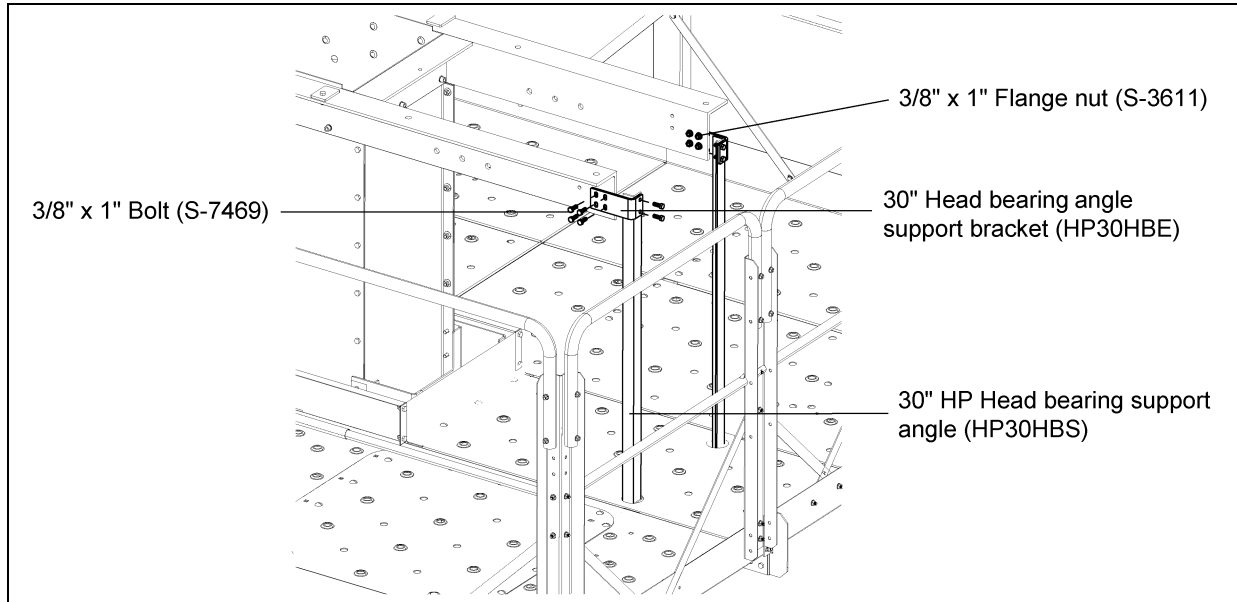

Figure 10A 30" Bearing Support Clips and Angles

Attach Head Bearing Support Angle to Lower Head for 36"

1. Place two (2) head bearing angle supports (HP36HBS) as shown in *Figure 10B.*
2. Connect to lower head and cross deck support channel with 3/8" x 1" bolts (S-7469) and nuts.

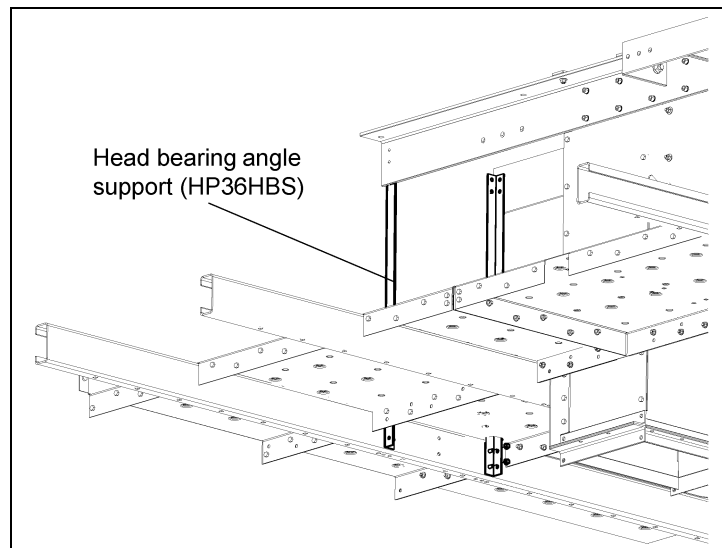

Figure 10B 36" Bearing Support Angle

Attach Handrail Supports to Deck E

1. Attach two (2) HP handrail supports (HP1648HSH) to Deck E using 3/8" x 3/4" bolts and nuts.
(See Figure 10C.) **NOTE:** The supports that attach to Deck A and Deck F attach at the same time as the platform post.

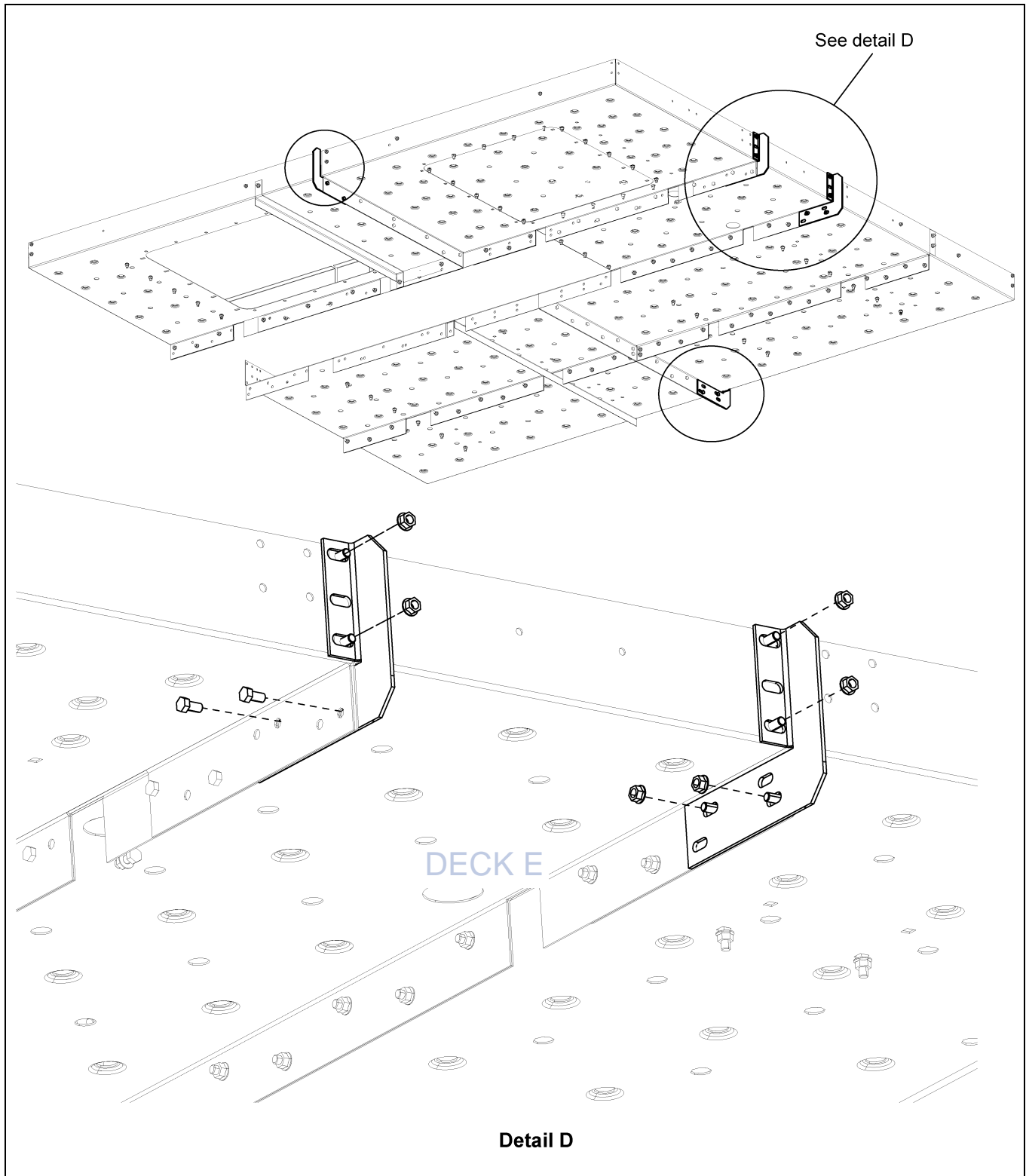

Figure 10C

Install Posts

1. Attach two (2) "W" posts (HP1648HWP) to the corner of Deck F using 5/16" x 3/4" bolts (S-6606) and nuts.
2. Attach platform post (HP1648HCP) and HP handrail support (HP1648HSH) to the middle of Deck F. Use 5/16" x 3/4" bolts (S-6606) to attach post to deck. Use 5/16" x 3/4" bolts (S-6606) to attach support bracket, post and deck together. (See Figure 10D.)
3. Attach platform posts to Deck A and Deck C as shown in Figure 10D. Use four (4) 5/16" x 3/4" bolts (S-6606) and nuts for each post.

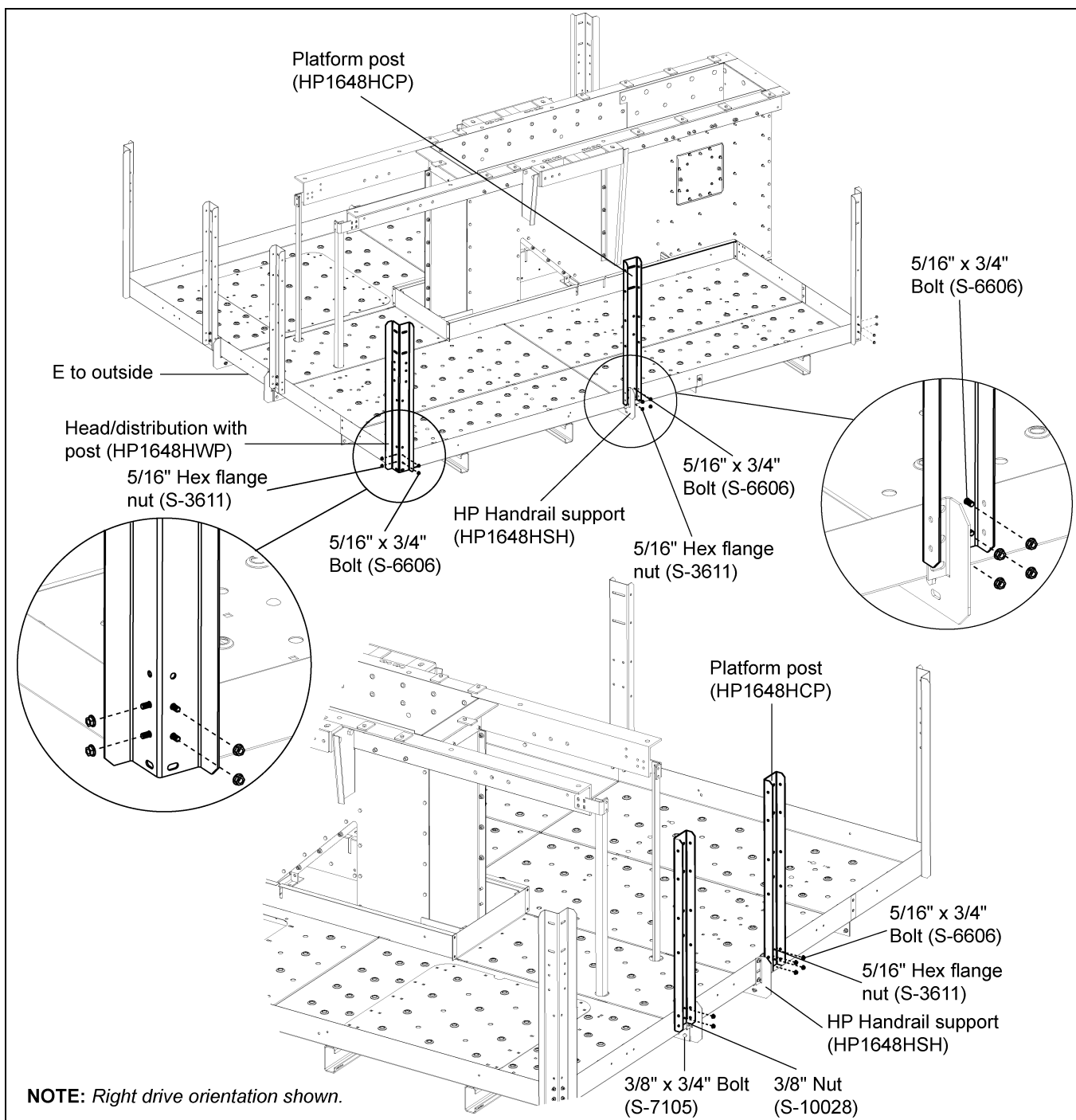

Figure 10D

Install Head Side Posts

For 30" Side Posts

1. Install side post (HP1648HP) to decking. *(See Figure 10E.)*

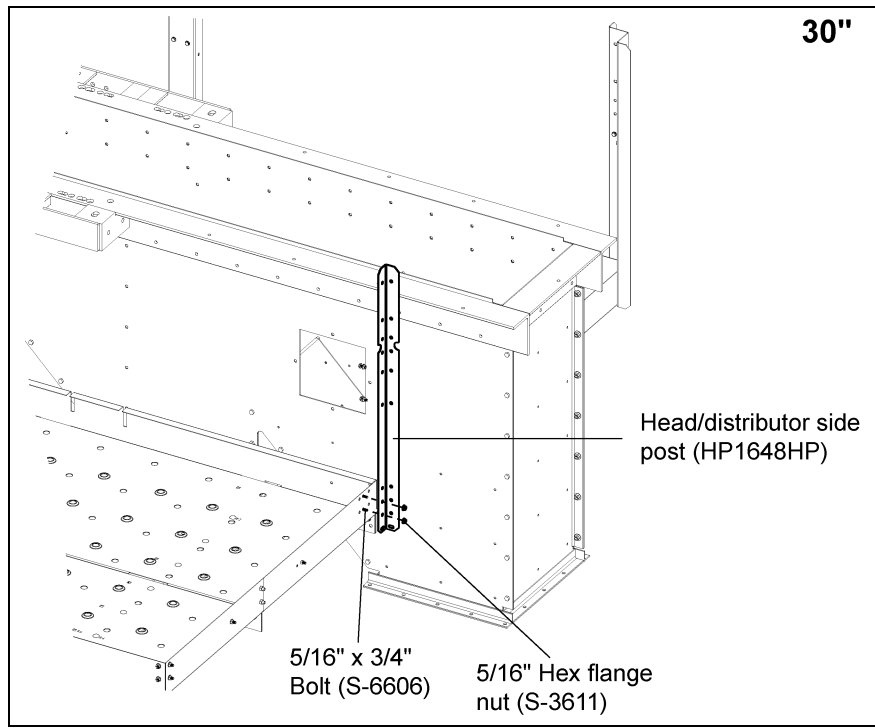

Figure 10E

2. Install handrail support bracket (HP30XHSPPT) from toe board to side post (HP1648HP) using 5/16" x 3/4" bolts and nuts. *(See Figure 10F.)*

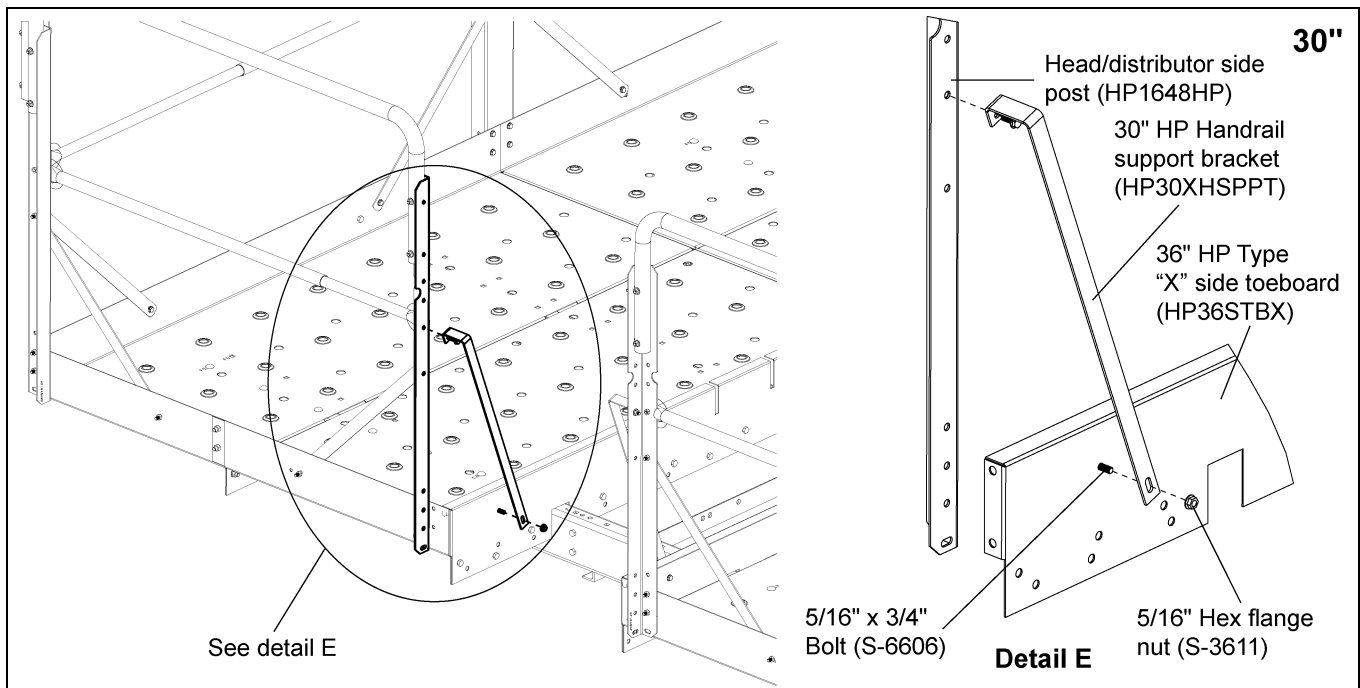

Figure 10F

For 36" Side Posts

1. Attach two (2) HP handrail supports (HP1636HS) to lower head using 3/8" x 1-1/4" bolt (S-2071) and nut. (See Figure 10G.)

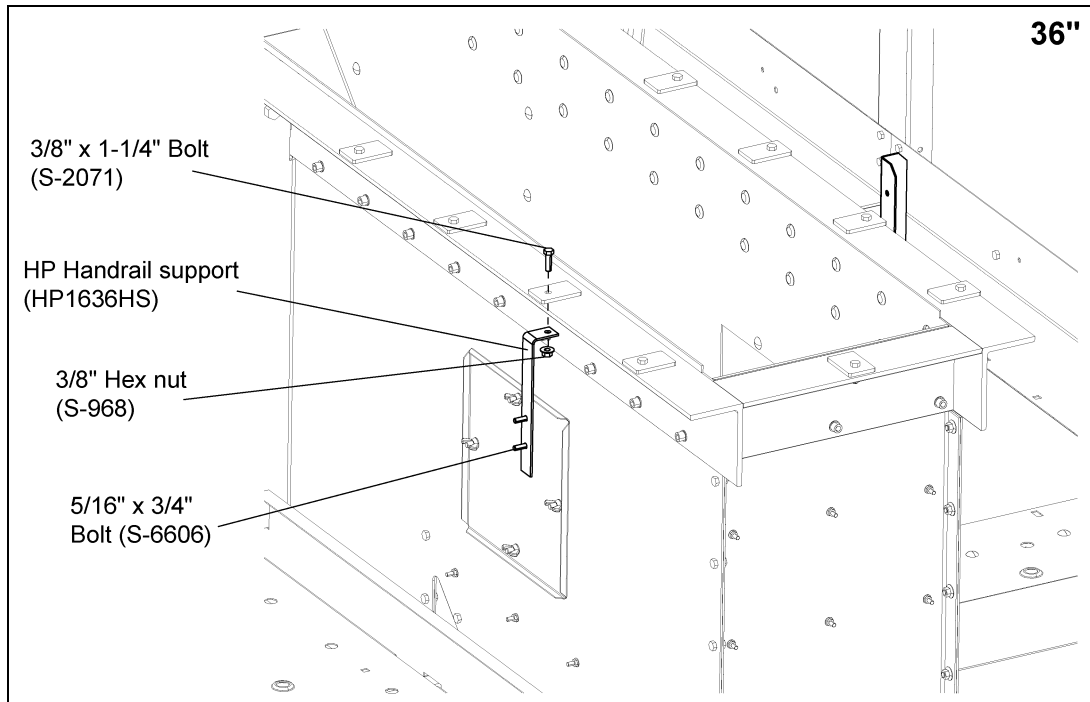

Figure 10G

2. Attach head side post (HP1648HP) to lower head using 5/16" x 3/4" bolts and nuts. (See Figure 10H.)

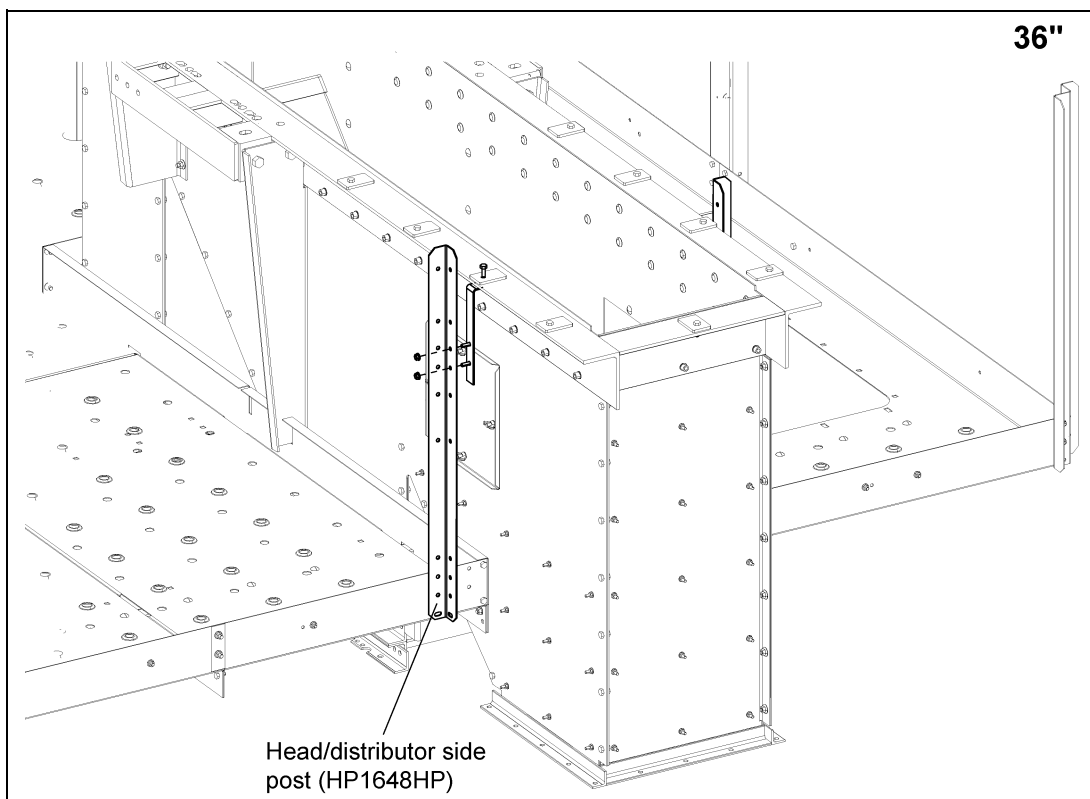

Figure 10H

10. 30"-36" Head Platform Post, Rails and Bracing

3. Attach side post to decking using 5/16" x 3/4" bolts and nuts. (See Figure 10I.)

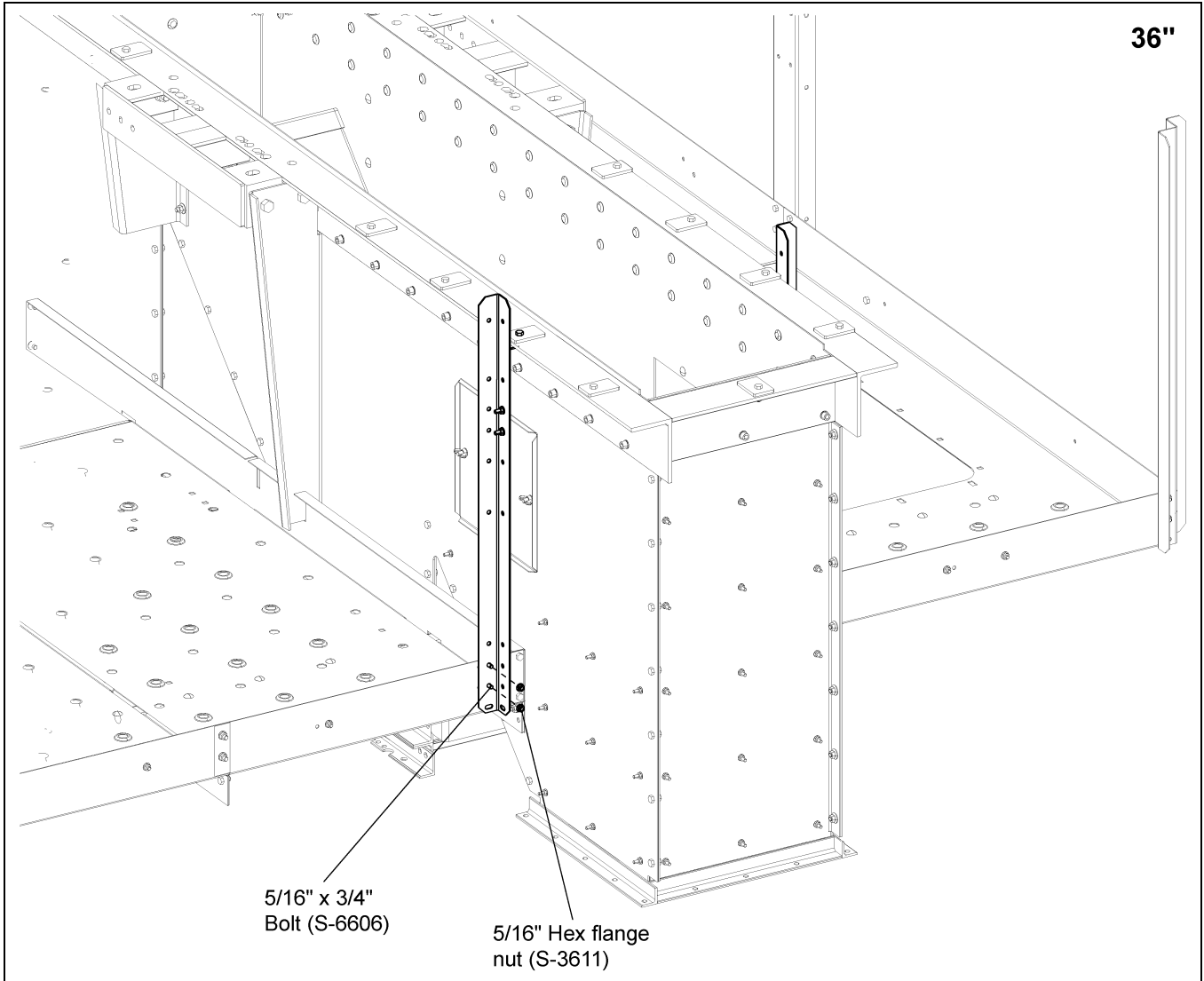

Figure 10I

Attach Intermediate Handrails to Posts

1. Cut 20" off the tube end of one small intermediate handrail (LDR-4088) and one large intermediate handrail (LDR-4087). (See Figure 10J.) Slide the small rail into the large rail and install between the posts opposite the discharge end and adjust to fit. Fasten using 5/16" x 3/4" bolts (S-6606) and nuts.
2. Cut 12" off the end of two (2) small intermediate handrail (LDR-4088) and two (2) large intermediate handrail (LDR-4087). (See Figure 10J.) Slide the small rails into the large rails and install one set at the discharge end of Deck A. Install the second set opposite the discharge end of Deck A. Fasten using 5/16" x 3/4" bolts (S-6606) and nuts.

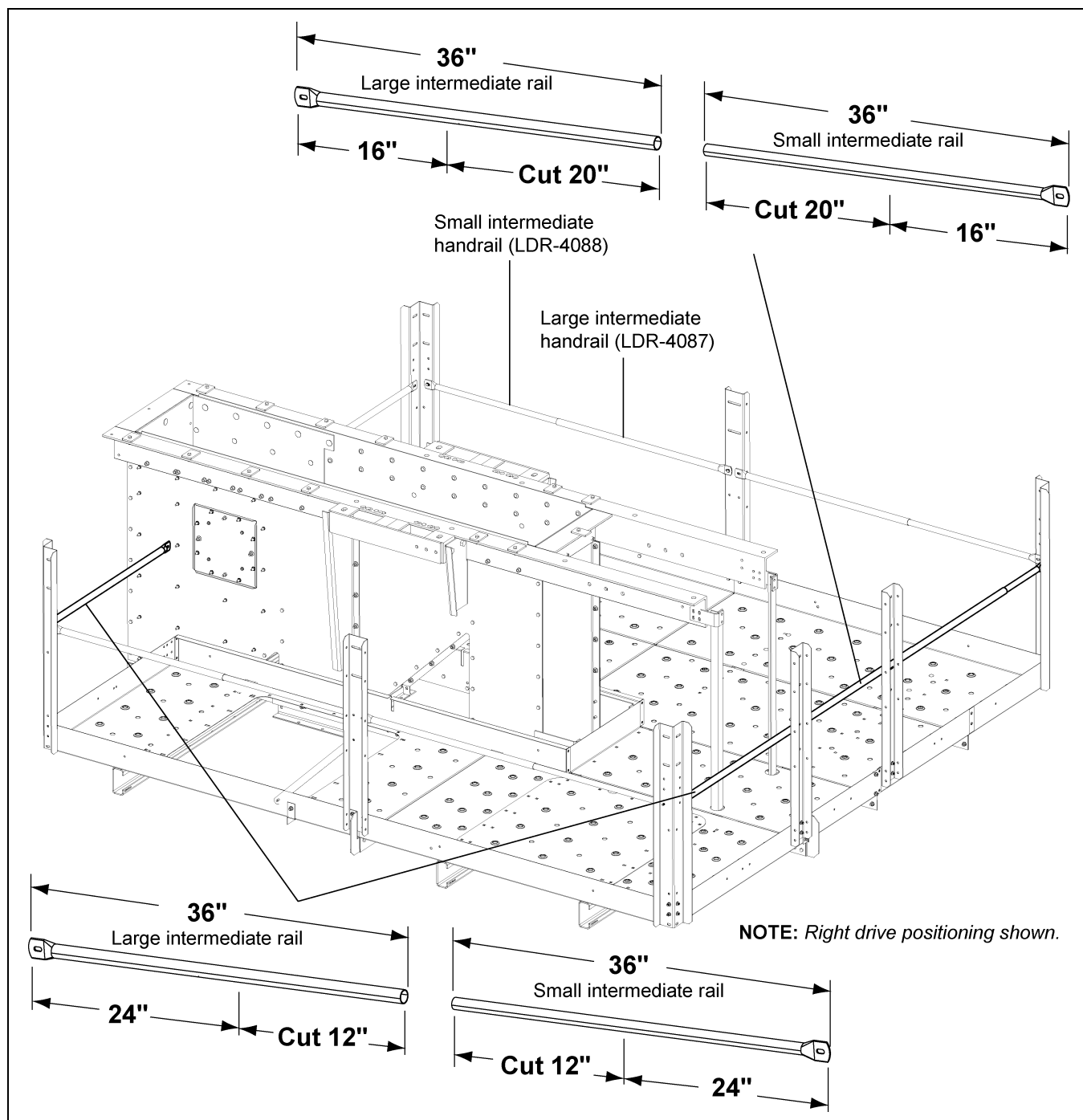

Figure 10J

10. 30"-36" Head Platform Post, Rails and Bracing

3. Install the remaining Intermediate handrails around the platform using 5/16" x 3/4" bolts (S-6606) and nuts. (See Figure 10K.)

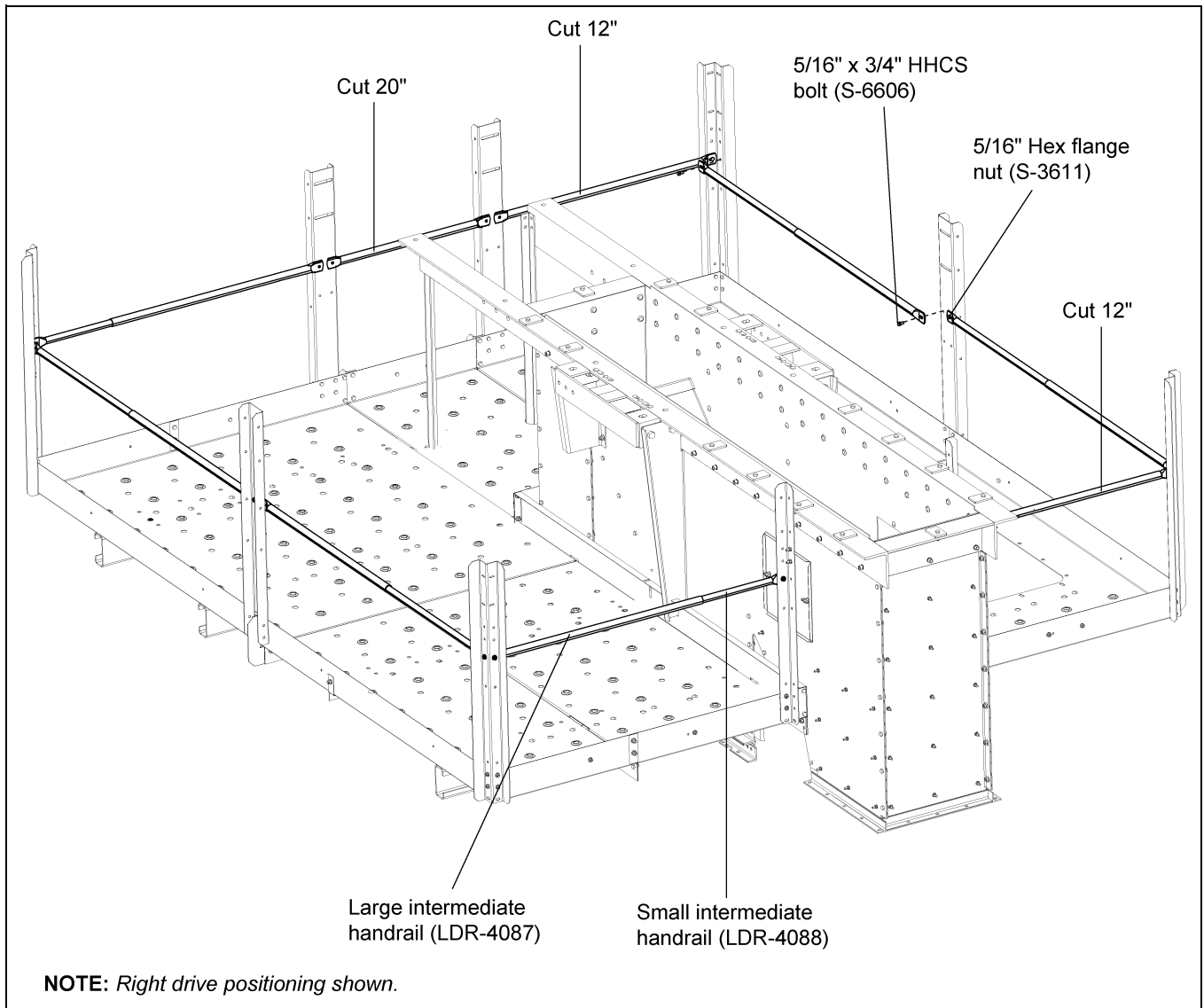

Figure 10K

Install Upper Handrails

1. Attach handrails to the handrail posts using 5/16" x 2" bolts (S-7877) and hex nuts. Use [Figure 10L](#) below [Figure 10M.](#) for handrail location.

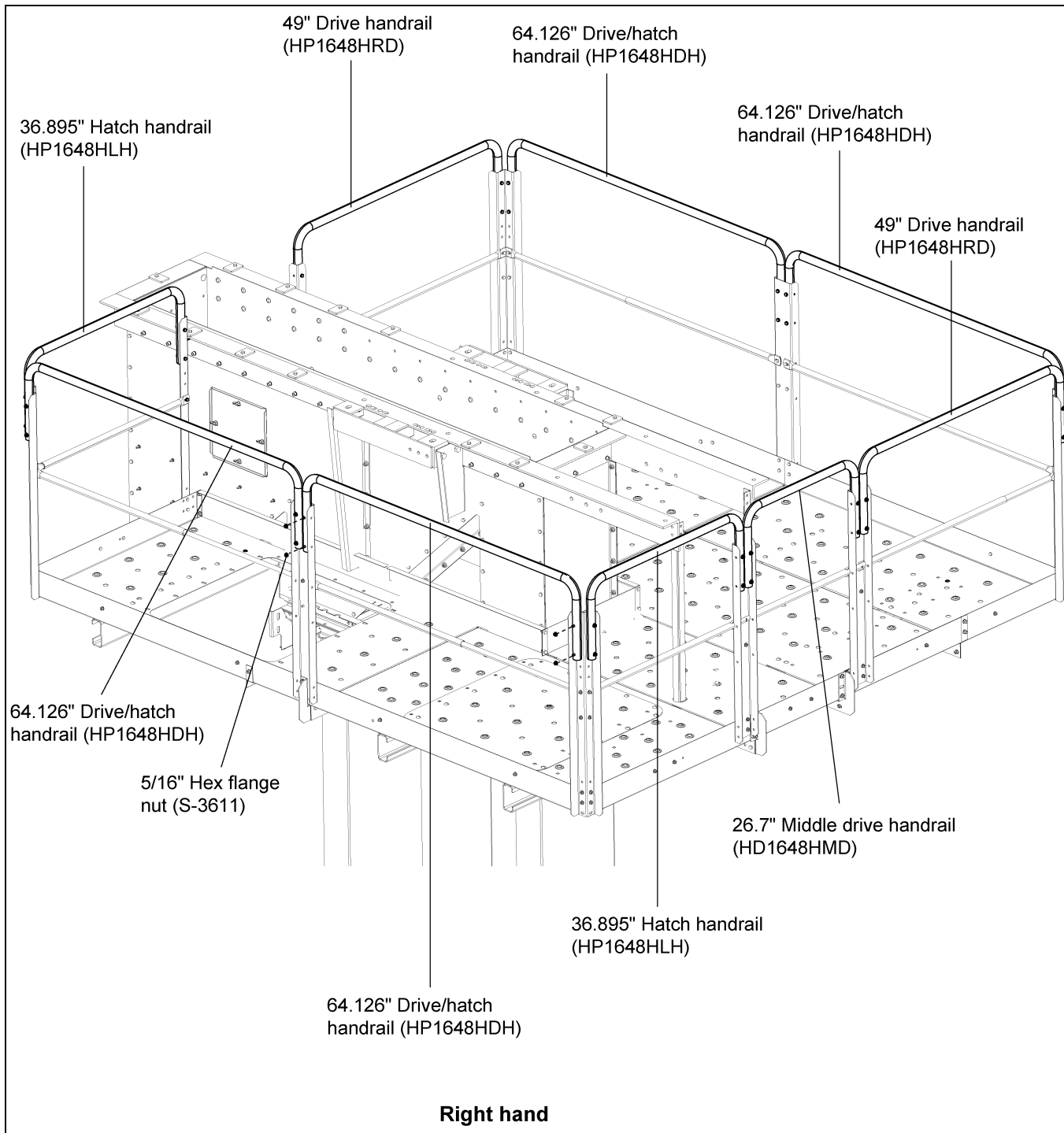

Figure 10L Right Hand Drive Rail Locations

10. 30"-36" Head Platform Post, Rails and Bracing

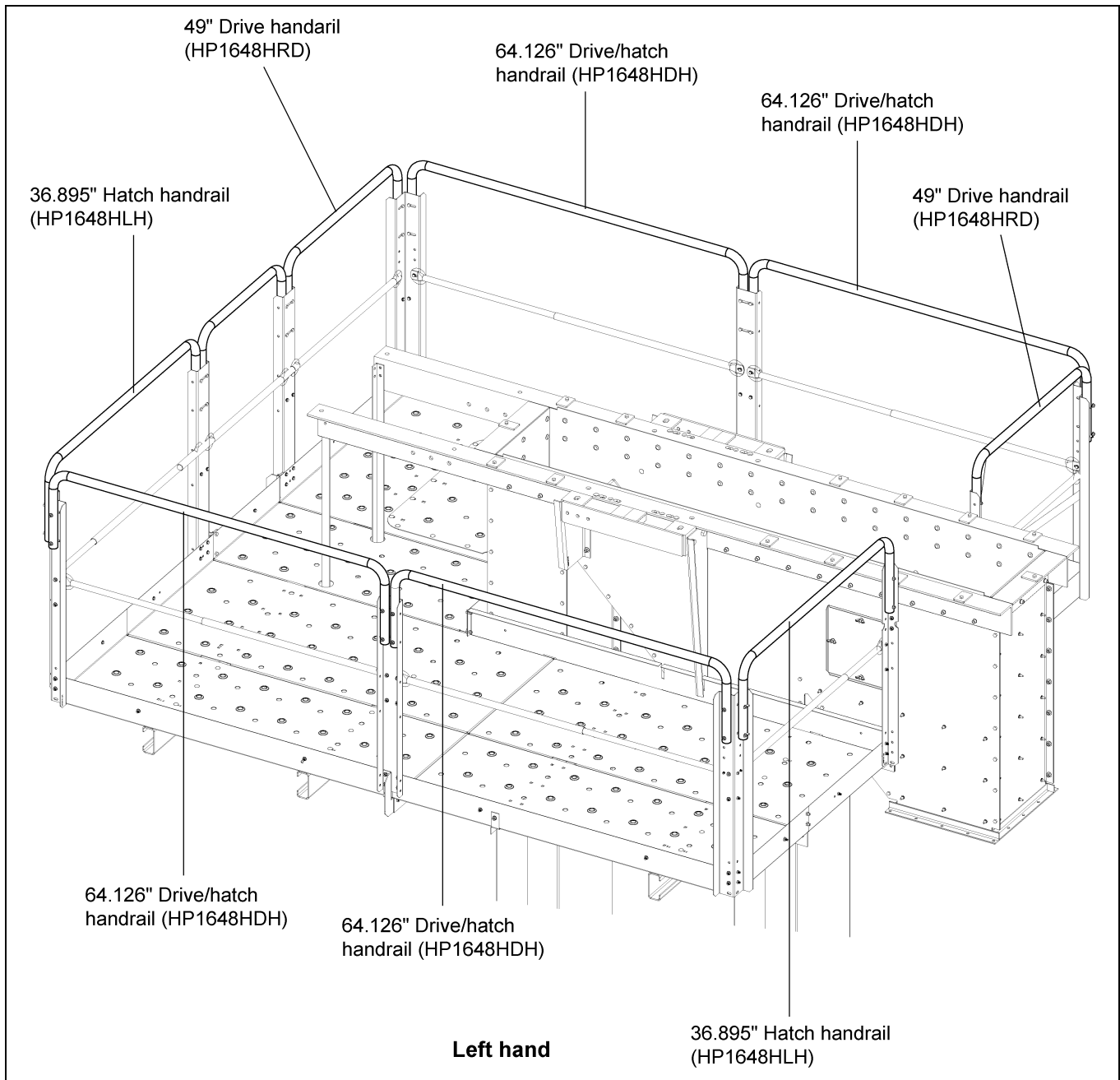

Figure 10M Left Hand Drive Rail Locations

Install Safety Cage Bar Cross Supports

1. Attach safety cage bar - 24" (LDR-5171BE) from handrail post to decking kick plates using 5/16" x 3/4" bolts and nuts. (See Figure 10N.)

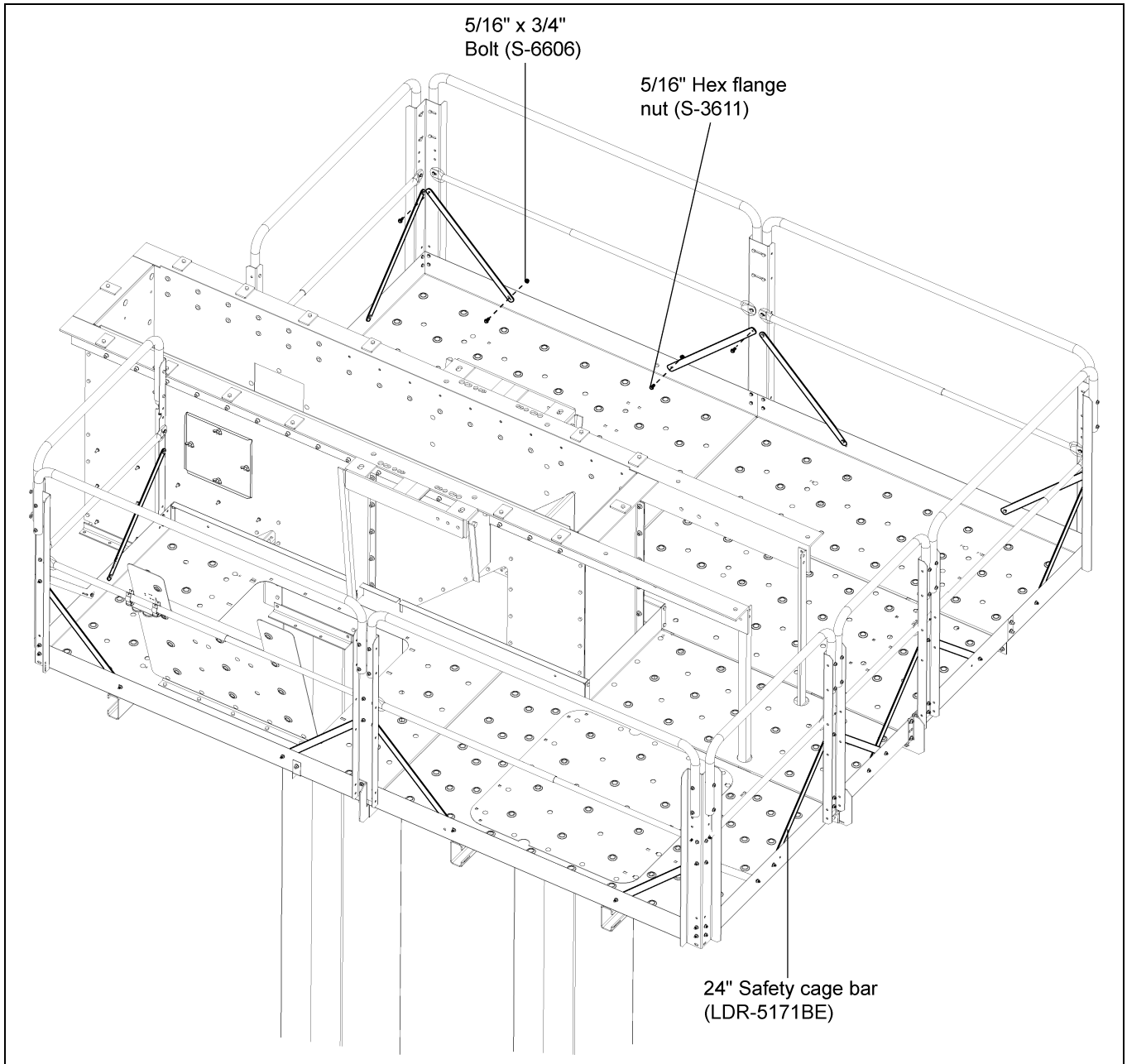

Figure 10N

Chapter 11: Install Hatch

1. Attach hatch hinge (HP1624HH) to the hatch deck door (HP1624HDD). Orient hinge so that it opens the desired direction. (See Figure 11A.) Fasten using 3/8" x 1" carriage bolts hardware.

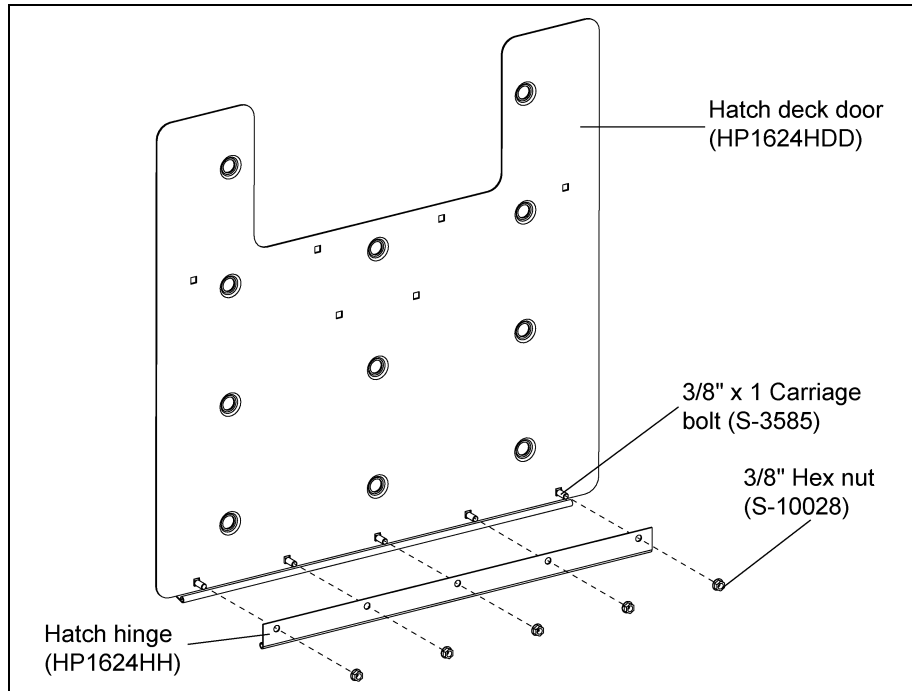

Figure 11A

2. Install hatch support (HP1624HS) to the bottom of the hatch door using 3/8" x 1" carriage bolts and nuts. (See Figure 11B.)
3. Fasten peak cap handle (PR-331) to the bottom of the hatch door using 3/8" x 1" carriage bolts and nuts.

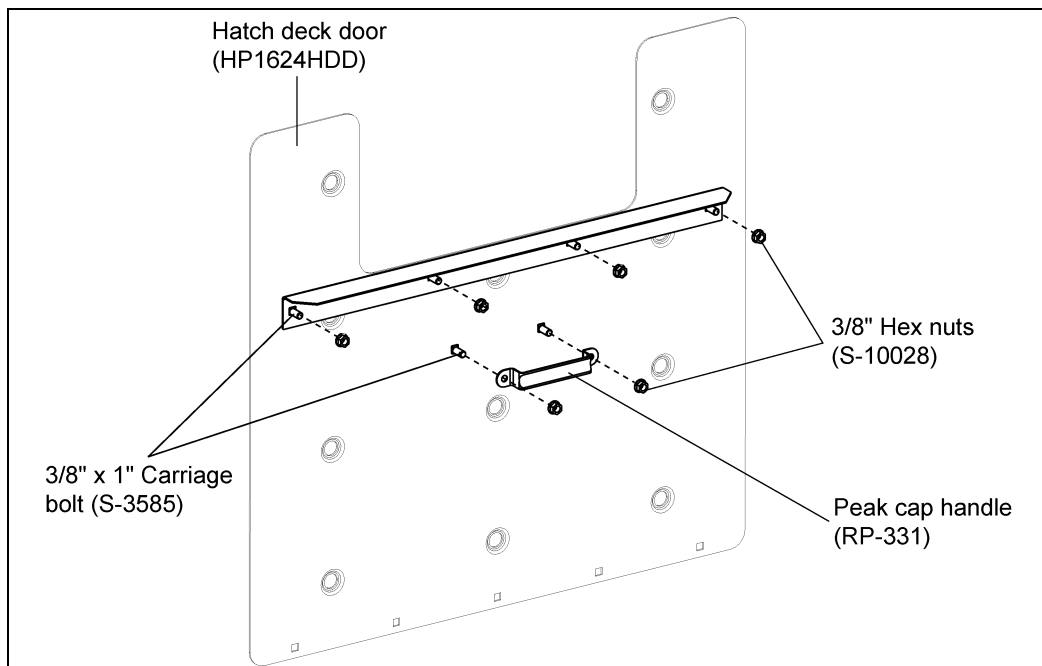

Figure 11B

4. Slide two (2) magnets (16-0092) onto each MS #6 x 3/4" FHS flat head screw (S-7166). Position the magnet so the screw head is countersunk into the magnet. *(See Figure 11C.)*
5. Insert screws with magnets through the hatch door and fasten with the #6 flange nut (S-10133).

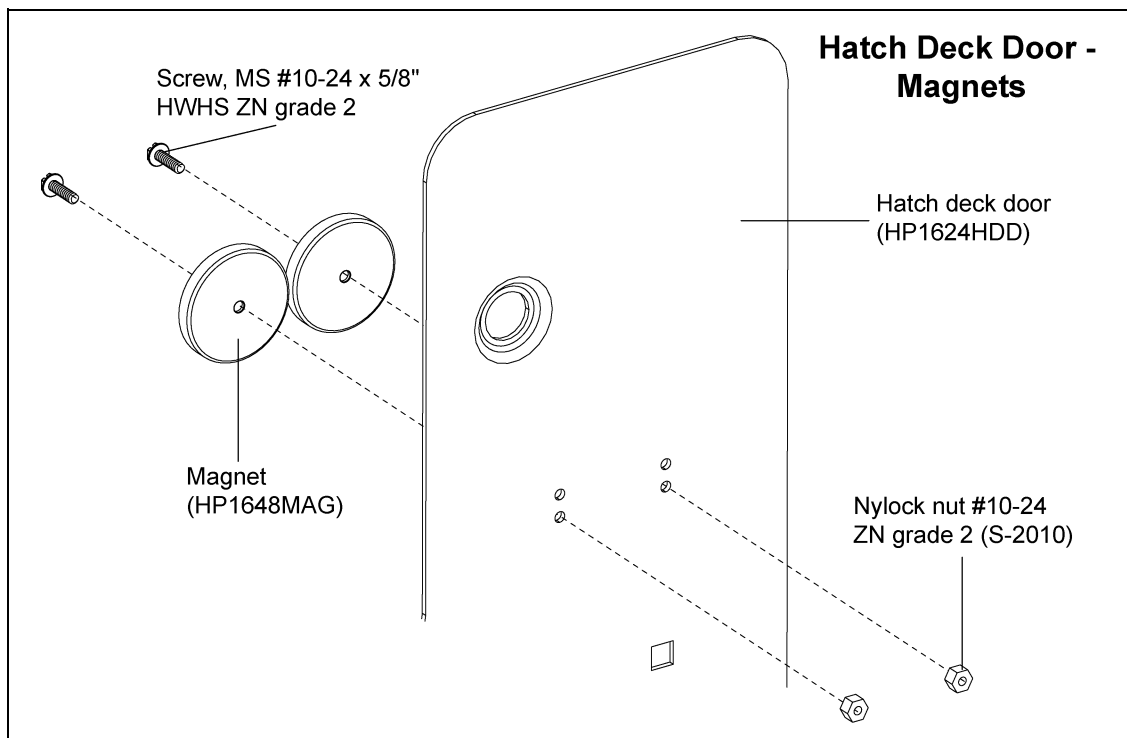

Figure 11C

6. Align holes on the hatch hinge with holes along the deck opening closest to the kick plates. Install the hatch door to the decking using 3/8" x 3/4" bolts (S-7105) and nuts. *(See Figure 11D.)*

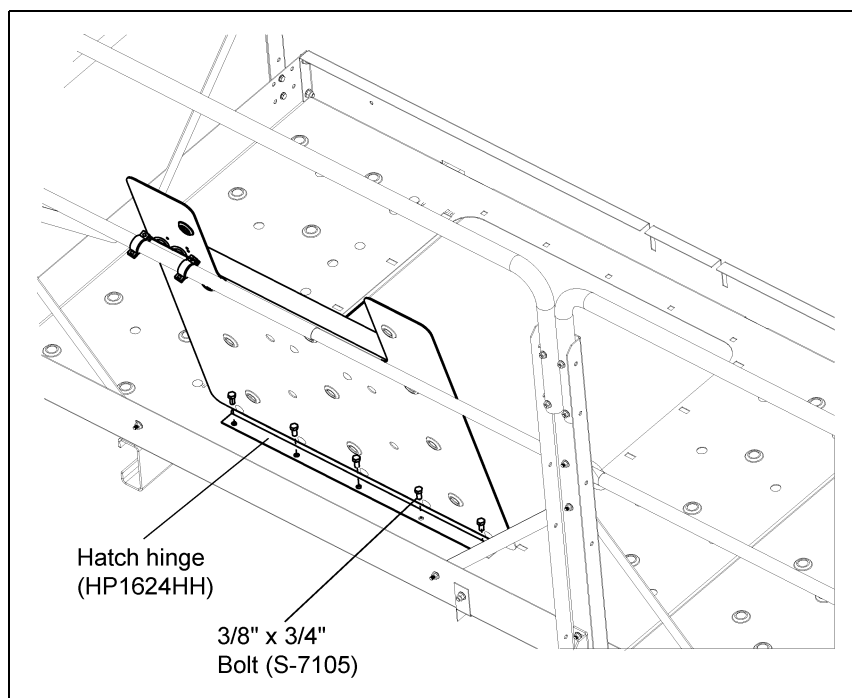

Figure 11D

11. Install Hatch

7. Assemble pipe clamps (S-10139) to the magnet mount hatch bracket (HP1648LMM). Insert 3/8" x 3/4" carriage bolts through the magnet mount hatch bracket, 1/2" flat washer and pipe clamp. Fasten with 3/8" nut. (See Figure 11E.)
8. Attach pipe clamp around intermediate handrail and fasten loosely with bolts. Open hatch plate and slide clamp along handrail until it lines up with the magnets on the hatch plate. Tighten clamp to rail.

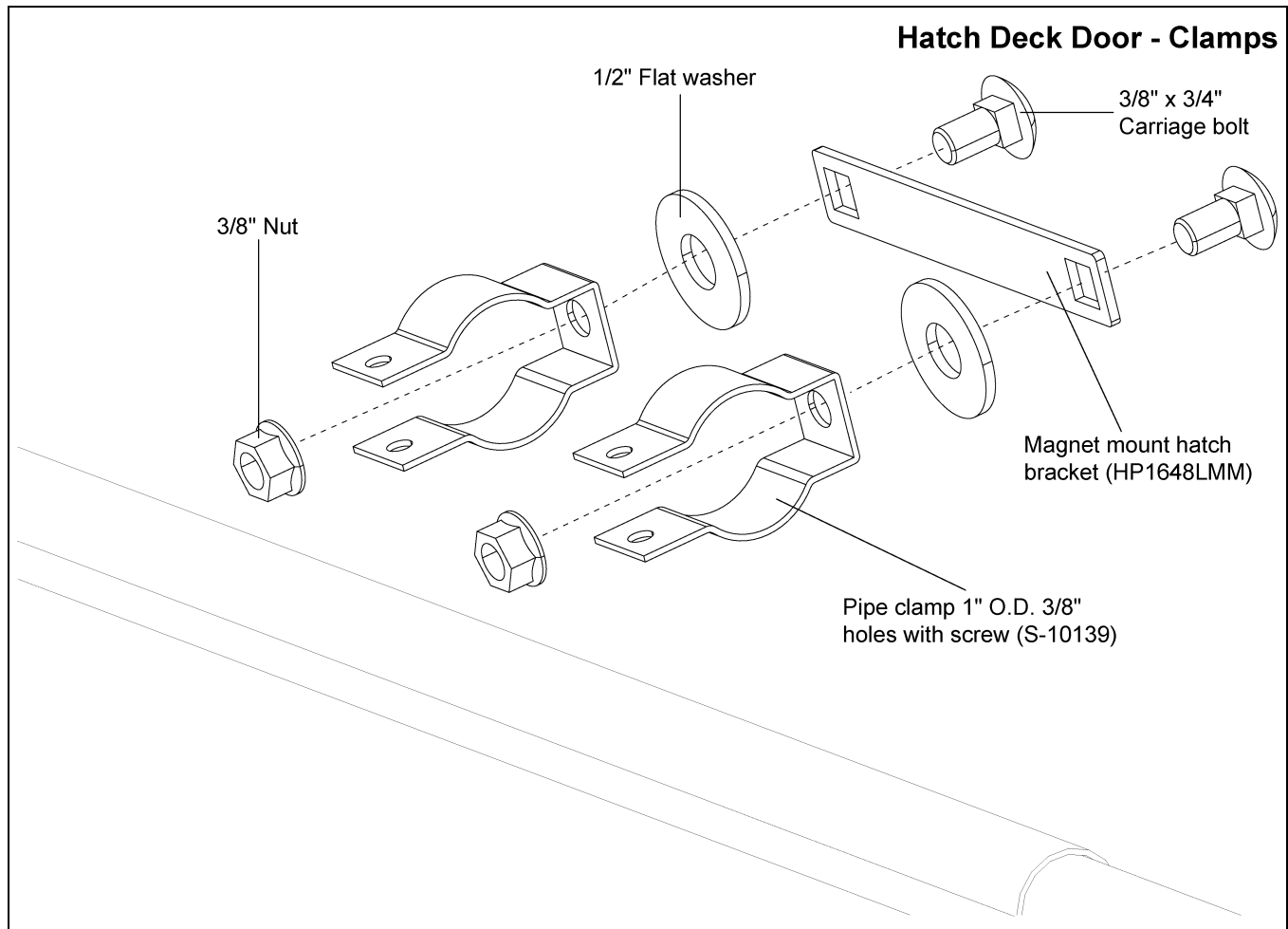

Figure 11E

Chapter 12: 4 x 5 Distributor Platform (Optional)

The distributor platform is optional and only used on bucket elevators that have a distributor spout. The platform is used to access the distributor for maintenance and control adjustments. The platform should be located below the distributor head. **NOTE:** That the clamp installation to the trunking is different for 16", 24" and the 30"-36" but the rest of the assembly is the same.

Install Clamp Band

30"-36" Top Clamp Band to Trunking

NOTE: 30"-36" Top and bottom clamps assemble the same. One attaches to the support channel and one attaches to the brace channels.

1. Slide rods of clamp rod weldment into outside set of holes of clamp bands for both the top and bottom assemblies. Fasten together using four (4) 1/2" hex flange nuts per each clamp.
2. Assemble the top and bottom clamp band weldments, clamp channel and clamp clips at same time around the trunking. Place clamp rod weldment assembly around the trunking leg and line up holes on clamp channel and clamp clips with the **inside set of holes** on the clamp bands. Fasten all together using six (6) 1/2" x 1" bolts and nuts. (See Figure 12A.)
3. Line up the holes located at the end of the distributor support channels and brace channels with the holes on the clamp clips. Fasten together using four (4) 1/2" x 1" bolts and nuts.

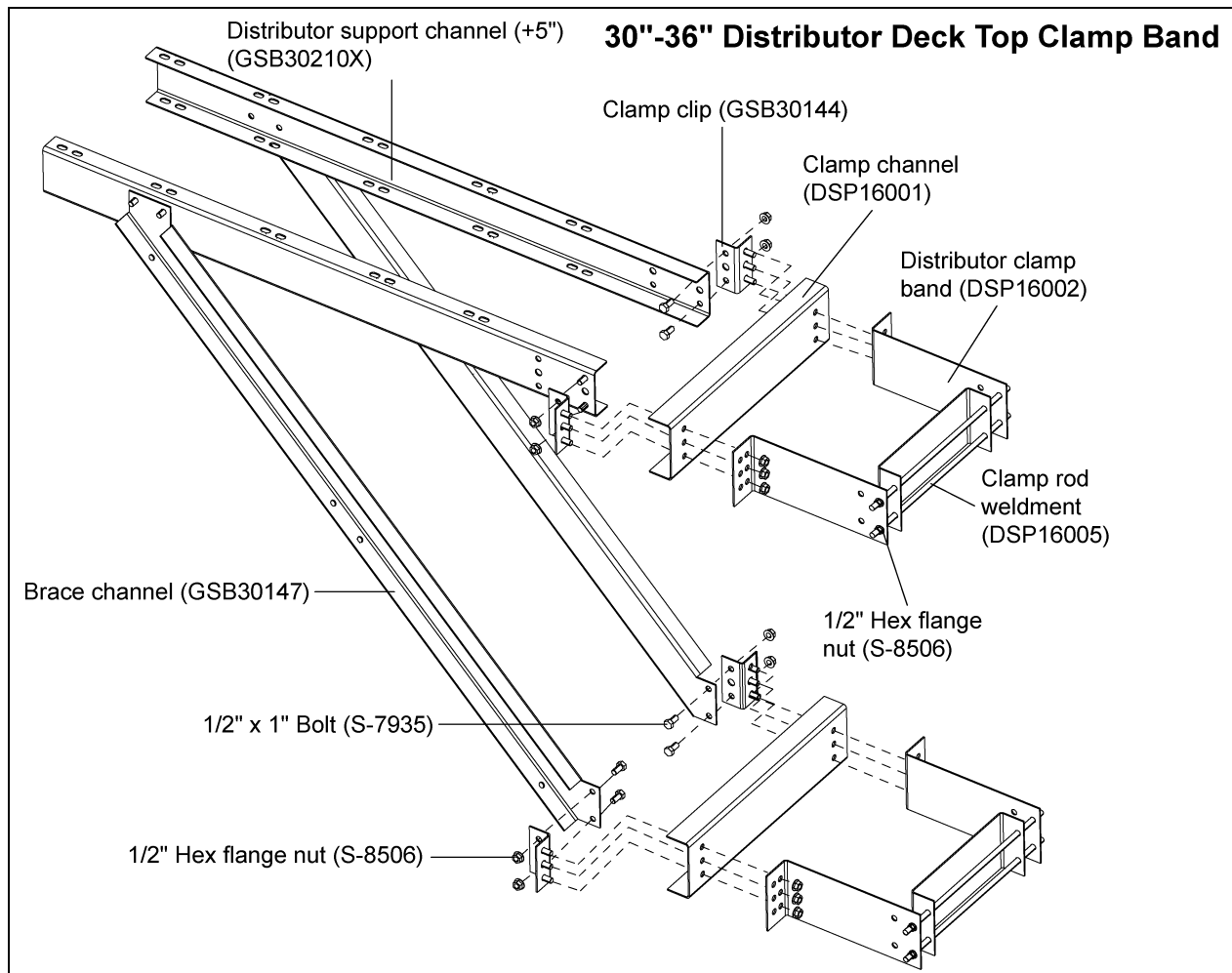

Figure 12A

12. 4 x 5 Distributor Platform (Optional)

Assemble Supports

Support Channel, Cross Support and Knee Brace Assembly

1. Attach brace channels to the sides of the support channels using four (4) 1/2" x 1" bolts and nuts. Angle the knee braces across the bottom sides of the brace channels and attach using four (4) 1/2" x 1" bolts and nuts.
2. Assemble the cross supports to the bottom side of the support channels using the end and middle sets of holes on the support channels using four (4) 1/2" x 1" bolts and nuts. (See Figure 12B.)
3. Assemble the external platform support (DSP1648EPS) to the end of the three (3) cross supports using six (6) 1/2" x 1" bolts and nuts. (See Figure 12C on Page 91.)

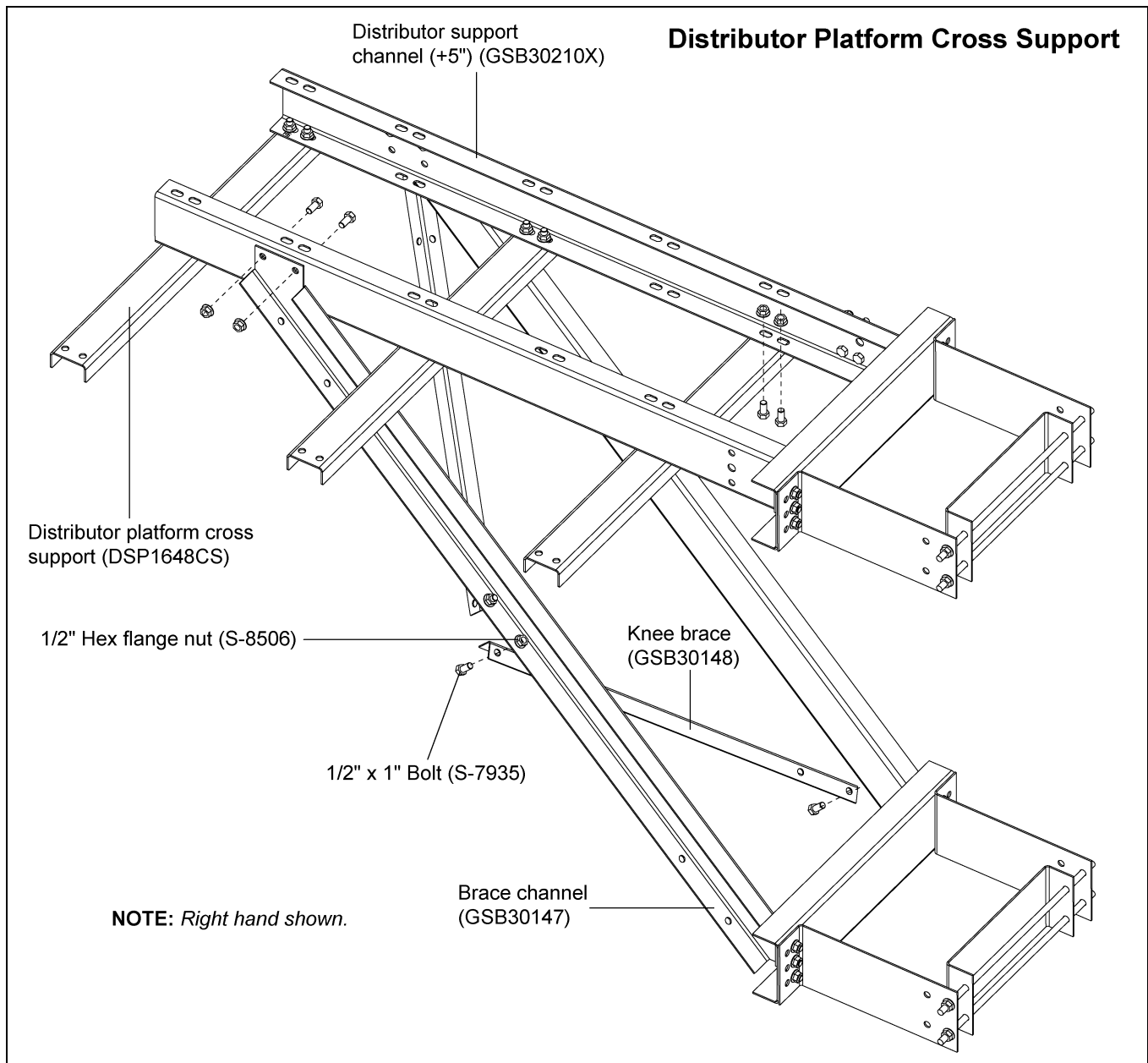

Figure 12B Distributor Platform Cross Support

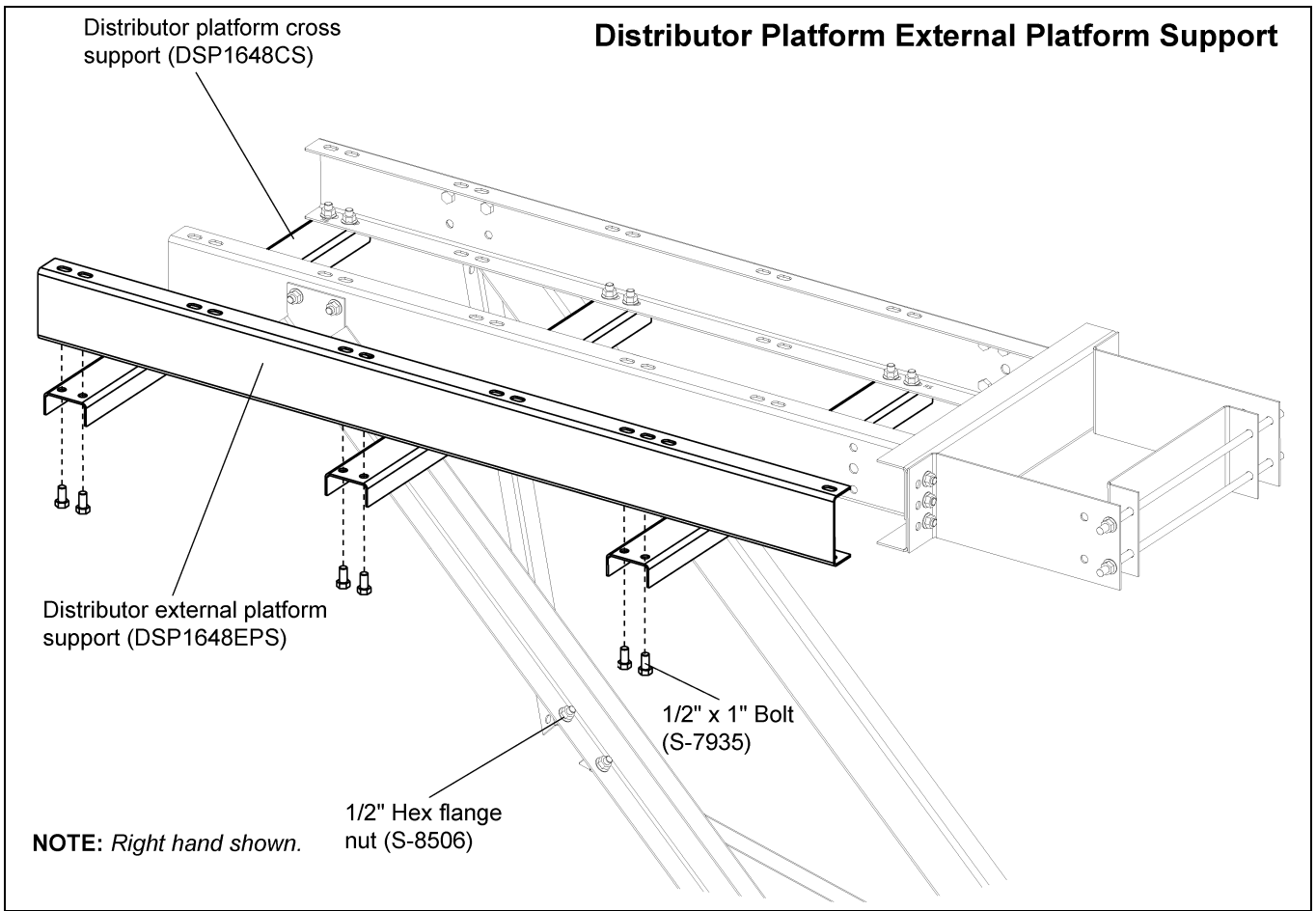

Figure 12C Distributor External Platform Support

12. 4 x 5 Distributor Platform (Optional)

Assemble Decking

1. Align A6 and A8 on platform decking weldment with A6 and A8 on the external platform supports.
2. Install platform decking weldment to the platform support channels using twenty four (24) 1/2" x 1" bolt and nuts. (See Figure 12D.)
3. Attach the flange of the toe board short side to the bottom of the 18" decking using two (2) 1/2" x 1" bolt and nuts. Then attach 18" decking to the external platform support using one 1/2" x 1" bolt and nut. (See Figure 12F on Page 93.)
4. Align flange of end toe board along the bottom of decking. Connect end toe board to decking using 1/2" x 1" bolts and nuts. (See Figure 12G on Page 94.)
5. Install the corner "W" post at the same time as the toe board filler plate. Attach toe board filler plate to the decking toe boards located across from the entrance. Attach the flat end first using two (2) 5/16" x 3/4" flange bolts and nuts. Then line up the holes of the toe board filler plate with the decking toe board, while also aligning the holes of the "W" post on the corner. Fasten all three (3) together with four (4) 5/16" x 3/4" flange bolts and nuts. (See Figure 12G on Page 94.)

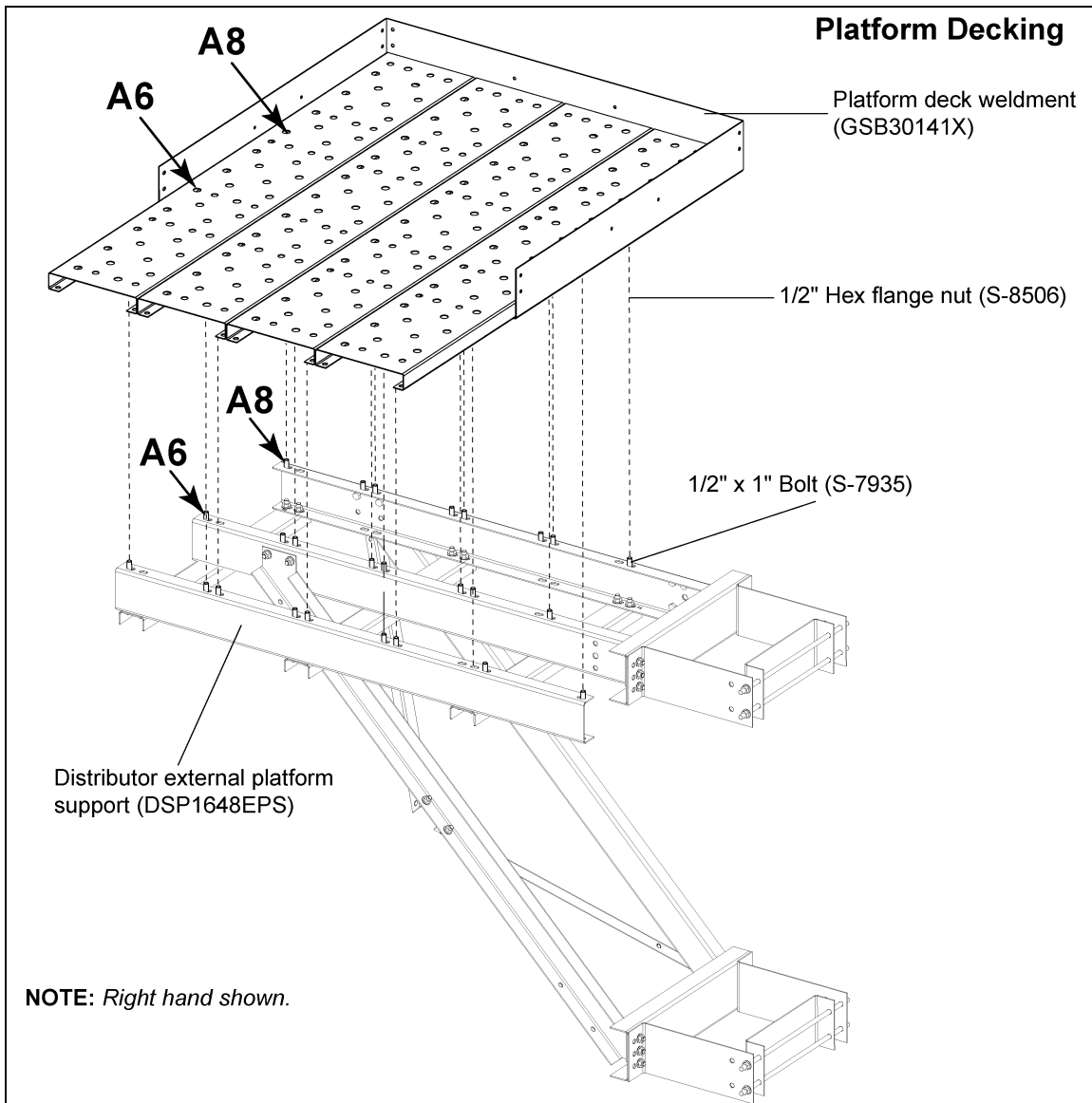

Figure 12D

12. 4 x 5 Distributor Platform (Optional)

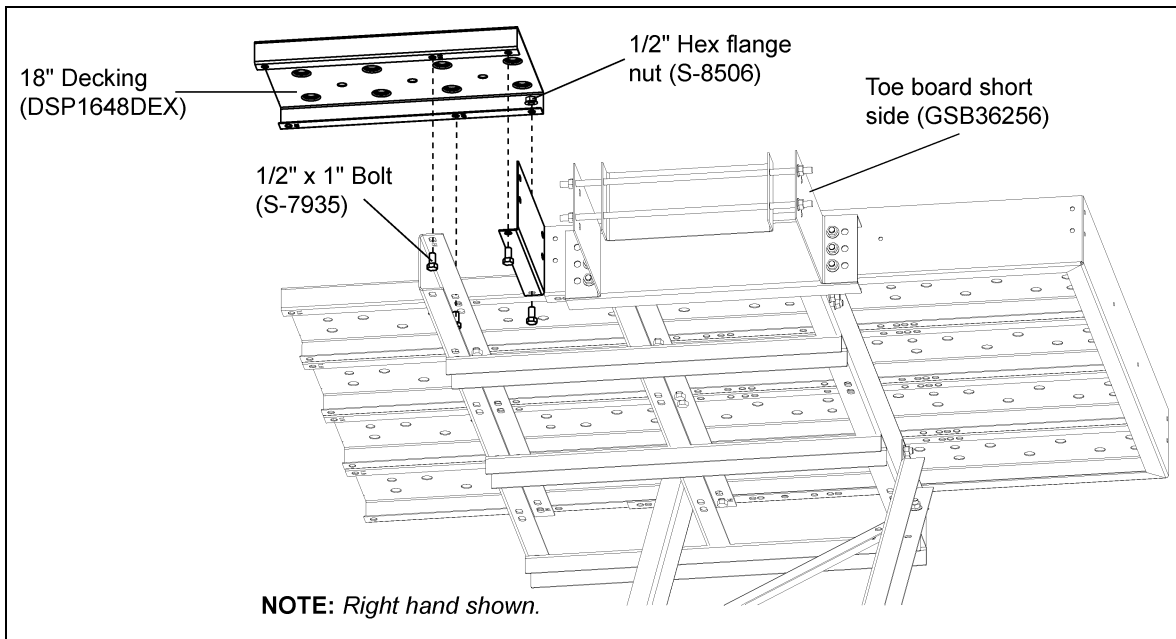

Figure 12E

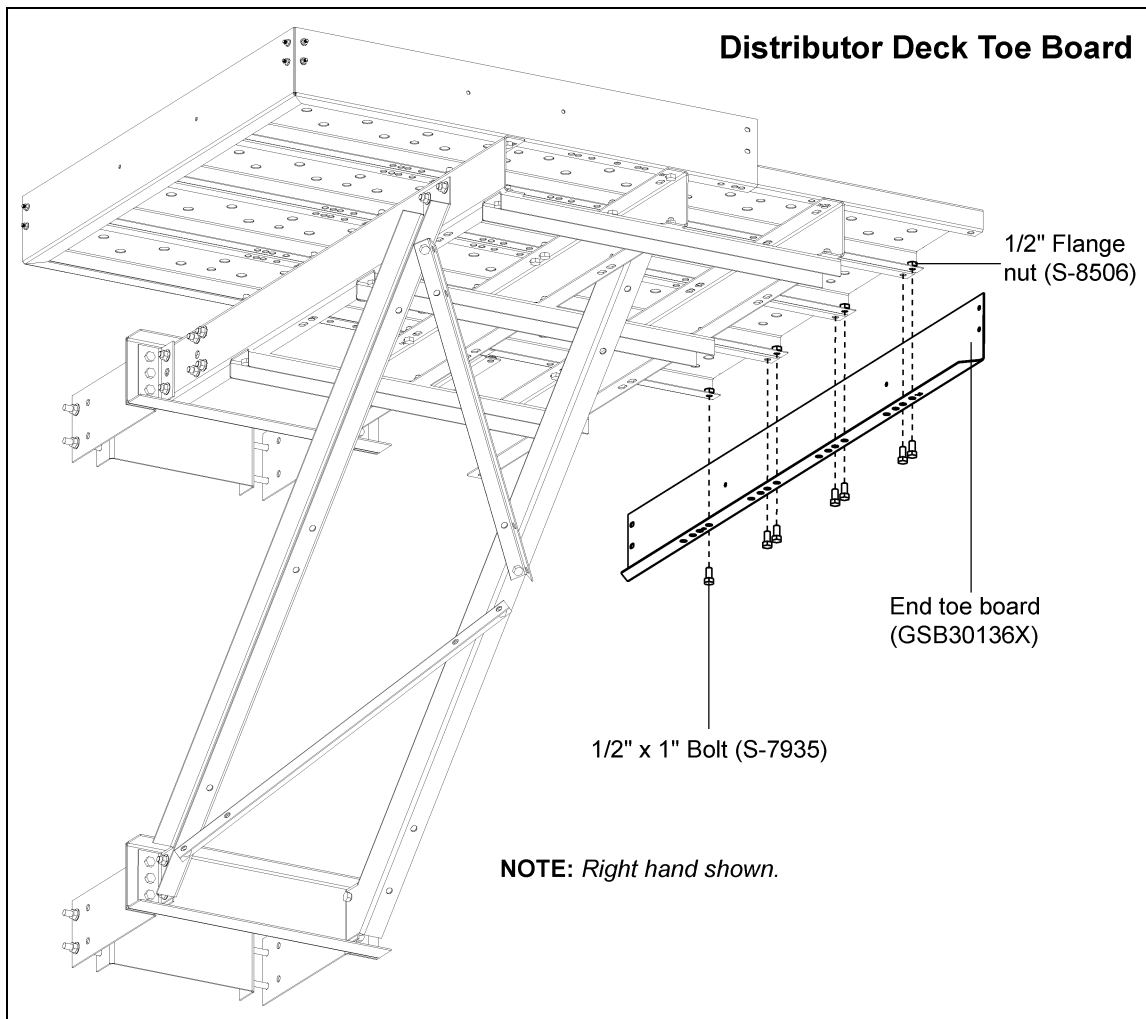

Figure 12F Distributor Platform Toe Board

12. 4 x 5 Distributor Platform (Optional)

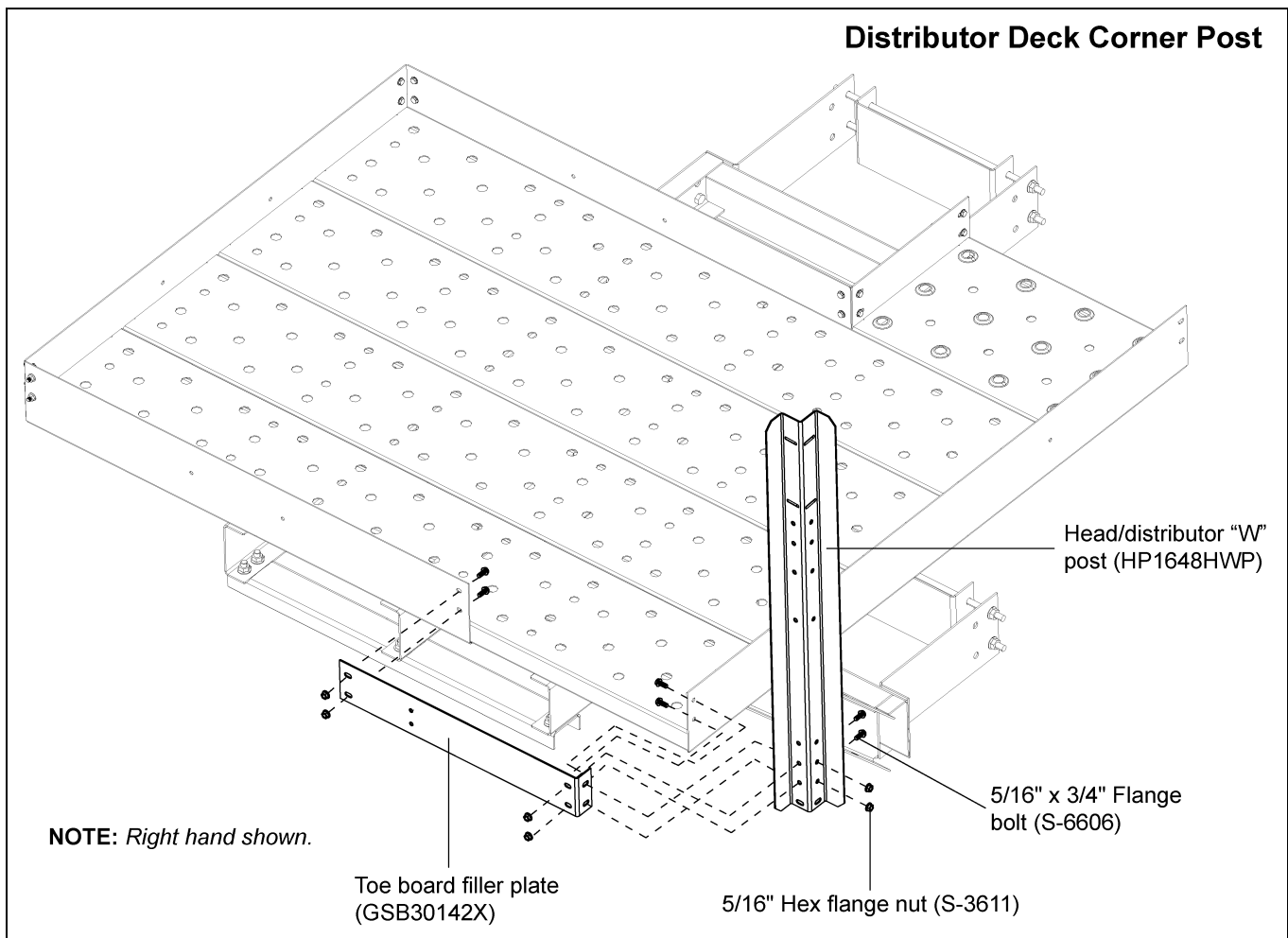

Figure 12G Distributor Platform Corner Post

Install Handrail Posts - Non Entrance Side

1. Install the remaining two (2) "W" corner posts to the corners on the non-entrance side of the decking using four (4) 5/16" x 3/4" flange bolts and nuts per post.
2. Install platform post (HP1648HCP) to the inside corner of the decking near the entrance to the platform using four (4) 5/16" x 3/4" flange bolts and nuts.
3. Attach side posts (HP1648HP) to the decking at the entrance to the platform using two (2) 5/16" x 3/4" flange bolts and nuts per post.

12. 4 x 5 Distributor Platform (Optional)

4. Install distributor handrail support to the side post on the inside, located closest to the trunking through holes 3 and 4 counting from the top of the post. Use two (2) 5/16" x 3/4" flange bolts and nuts to fasten in place. (See Figure 12H.)

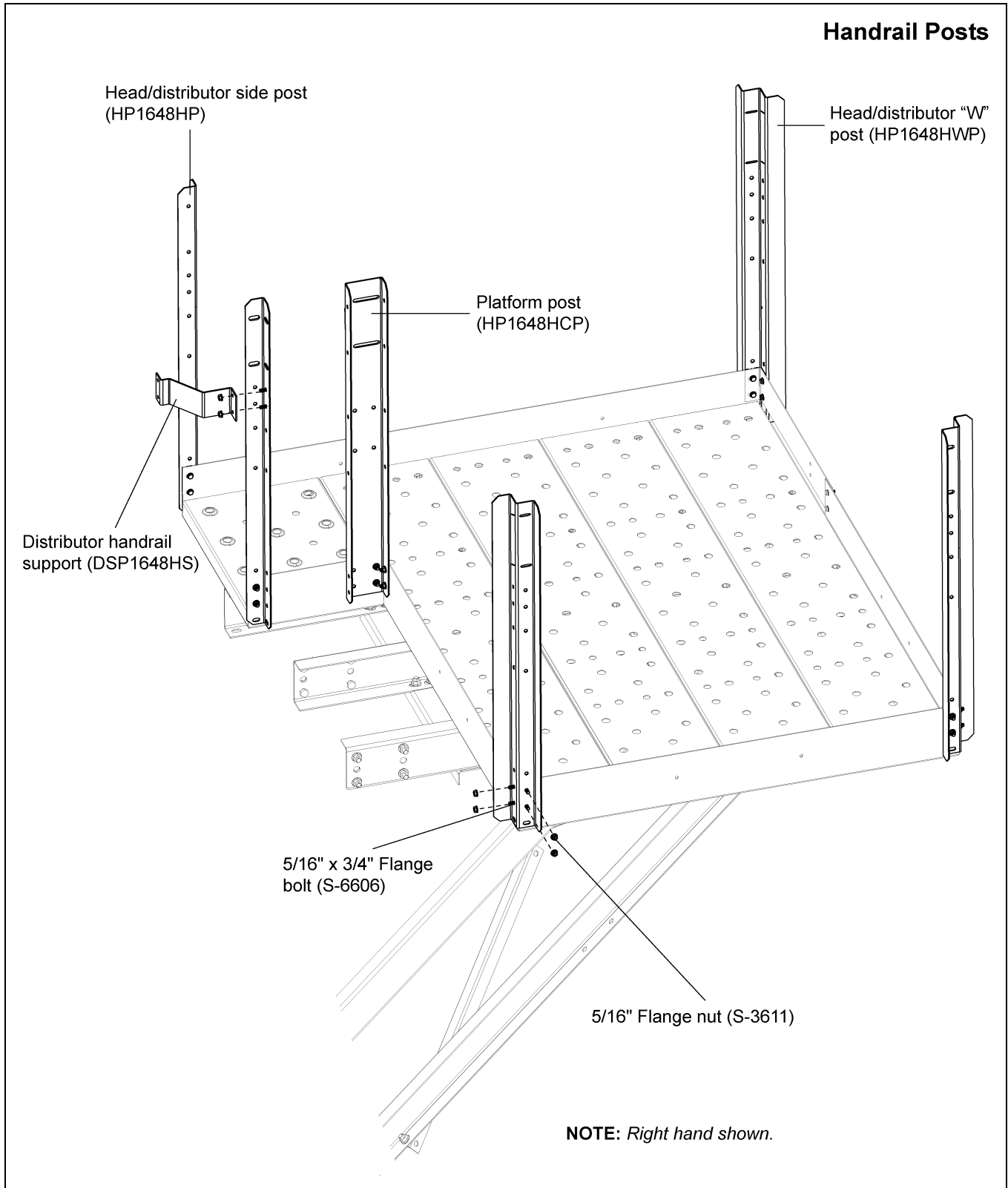

Figure 12H

12. 4 x 5 Distributor Platform (Optional)

Assemble and Install Intermediate Handrails

1. Insert small intermediate handrail into the large intermediate handrails to create telescoping rails. Cut 30" off one small intermediate and one large intermediate rail to fit at entrance. Adjust all rails to the proper length and install to the posts using the 5th hole down from the top. Fasten in place using two (2) 5/16" x 3/4" flange bolts and nuts per each telescoping tube. (See Figure 12I.)

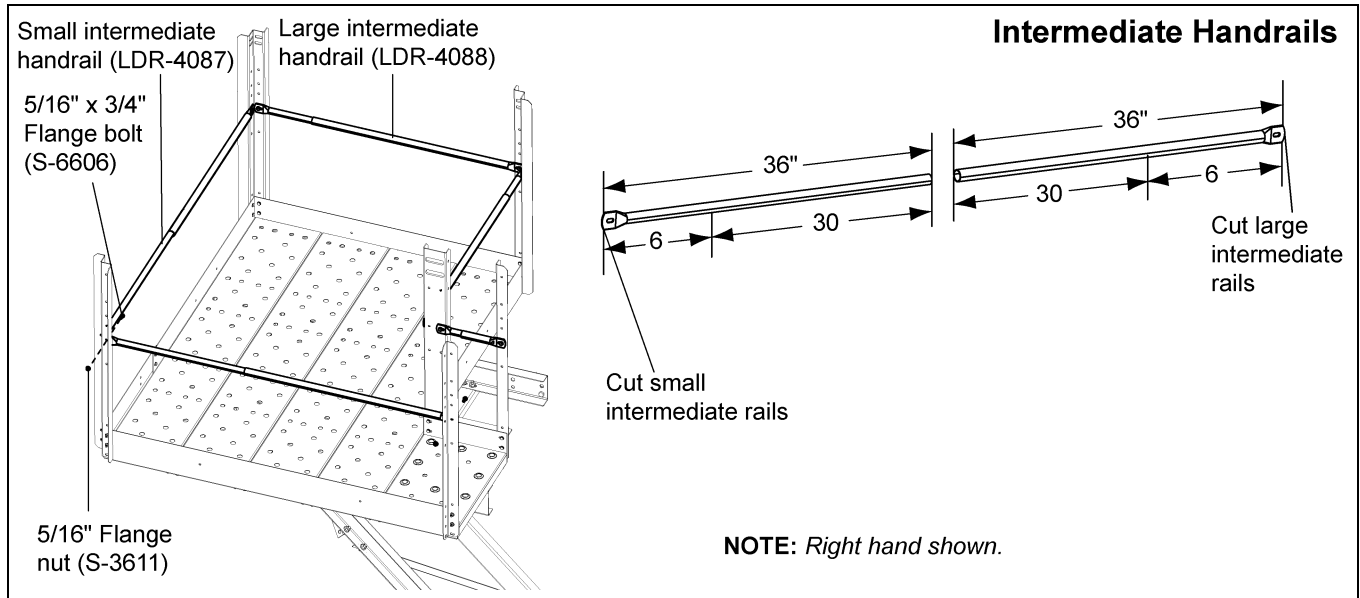

Figure 12I

Install Safety Bar Cross Supports

NOTE: Safety cage bars (LDR-5171BE) are used as tie braces in this installation.

1. Install safety bar cross supports from the decking toe board to the rail posts using two (2) 5/16" x 3/4" flange bolts and nuts per each cross bar support. (See Figure 12J.)

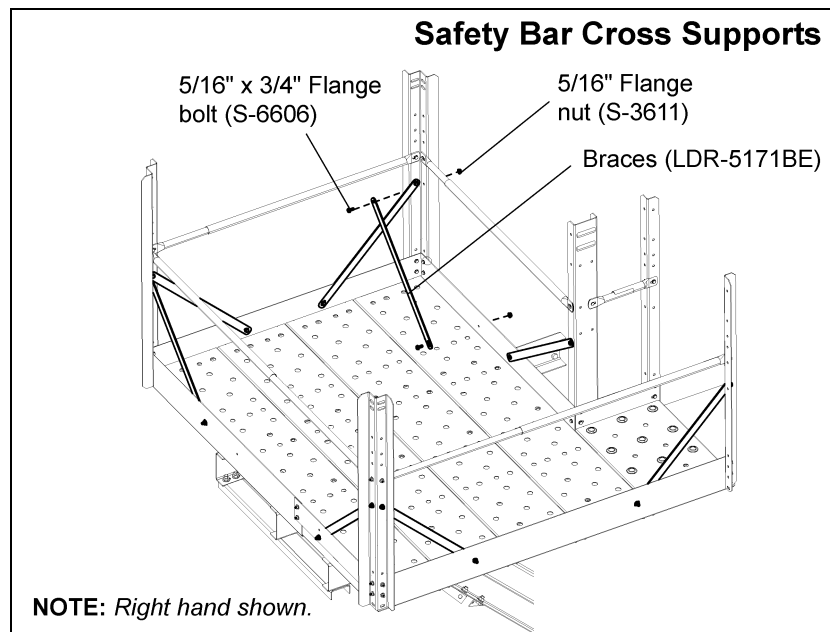

Figure 12J

Install Upper Handrails

1. Attach handrails to the posts using four (4) 5/16" x 3/4" flange bolts and nuts per handrail.
(See Figure 12K.)

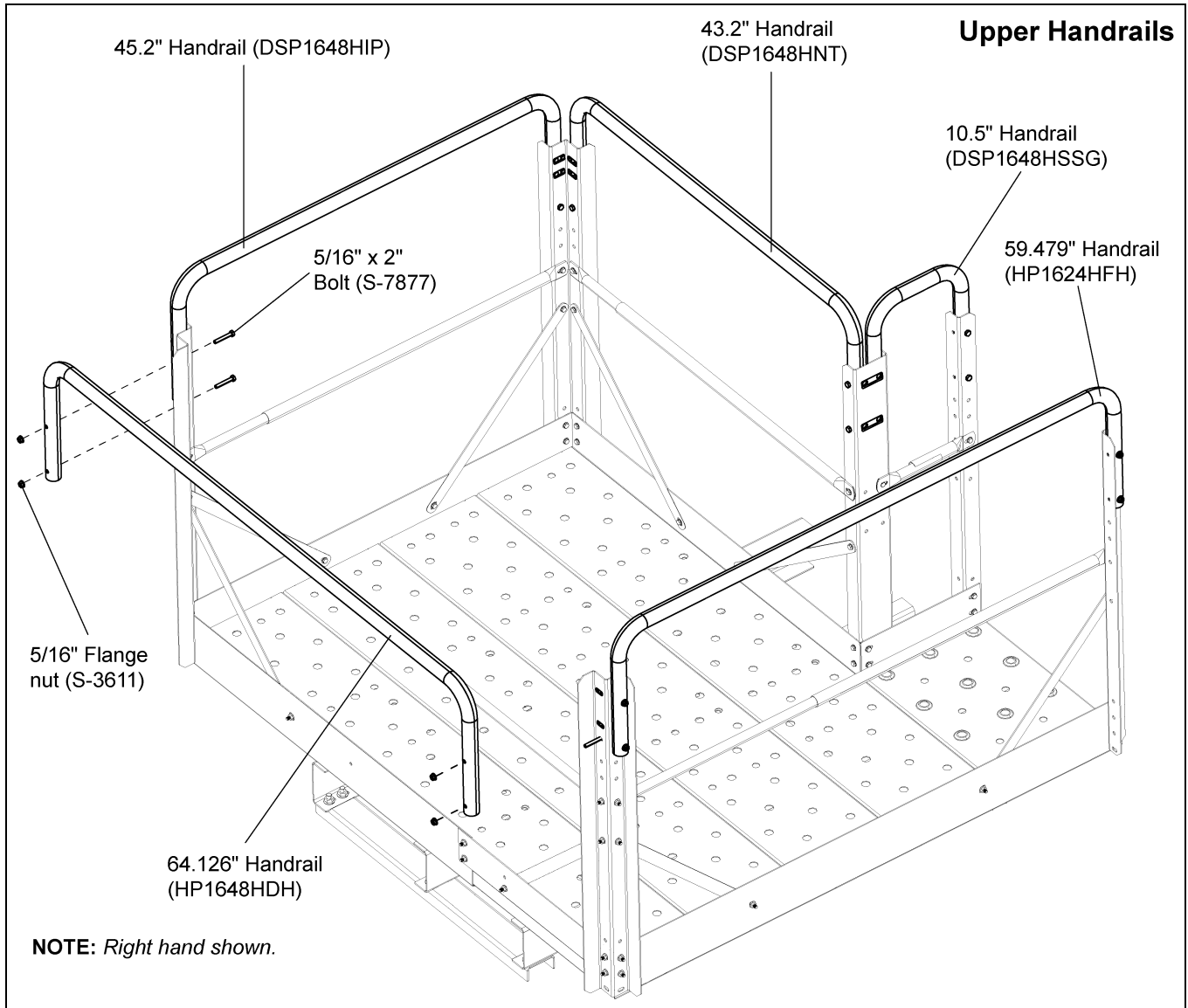

Figure 12K

12. 4 x 5 Distributor Platform (Optional)

Safety Gate Package (Optional)

IMPORTANT: Attach the platform gate bracket to the gate before attaching it to the inside platform post using 5/16" hardware.

Attach safety gate assembly to intermediate platform door bracket using 5/16" bolt (S-1196), 5/16" flat washer (S-845) and 5/16" flange nut (S-3611).

Attach intermediate platform door bracket to two (2) safety gate side posts (HP1648HP) using 5/16" bolt (S-1196), 5/16" flat washer (S-845) and 5/16" flange nut (S-3611). (See Figure 12L.)

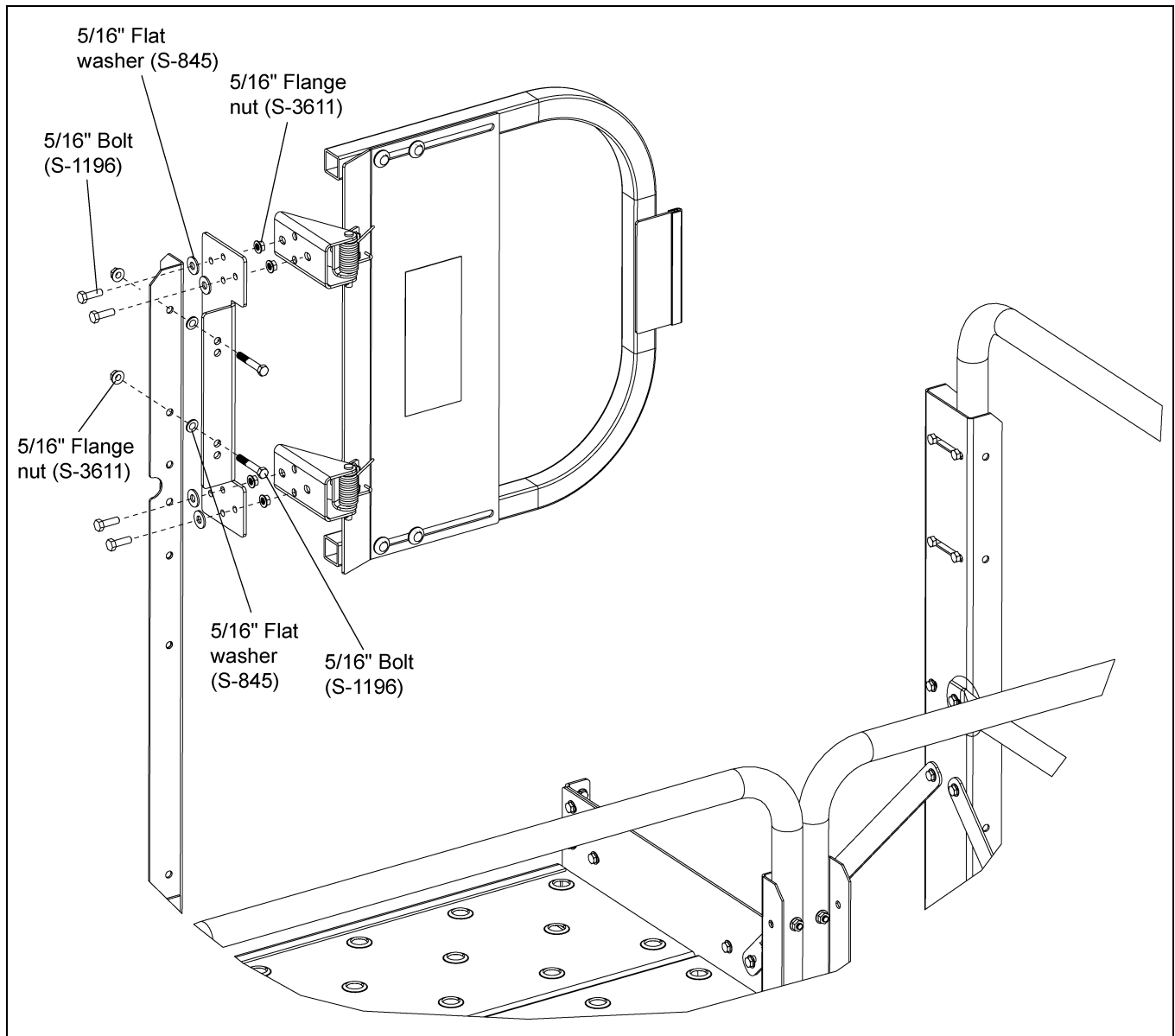

Figure 12L

Chapter 13: 6 x 6 Distributor Platforms

This assembly is designed to be located at any elevation on trunking that is needed to provide access to other equipment. Determine elevation of platform surface and work from there. Locate all parts required for assembly by using the chart as shown in *Figure 13A*.

Platform Clamps

Locate all clamp halves (DSP36007), clamp brackets (DSP36016), threaded rods (DSP36008) and hardware to assemble clamps onto the trunking.

Measure the distance between the clamps to assure proper location for support channels and knee brace attachment. See clamp detail in *Figure 13A* for hardware orientation.

Attach one clamp half to the end of each platform support channel using 5/8" hardware in the top and bottom holes of the bracket.

Insert rod through the middle hole in the brackets attached to the platform support channel. Fasten using 5/8" nut, 5/8" lock washer and two (2) flat washers.

Place brackets with support channels attached around trunking and fasten in place with clamp bracket using 1/2" hardware.

Adjust the position of the inside nuts of the rod assembly to allow the clamps to be tightened onto the trunking.

NOTE: *Tighten clamps onto trunking, do not overtighten and collapse the trunking. Position inside nuts back to the clamp and tighten.*

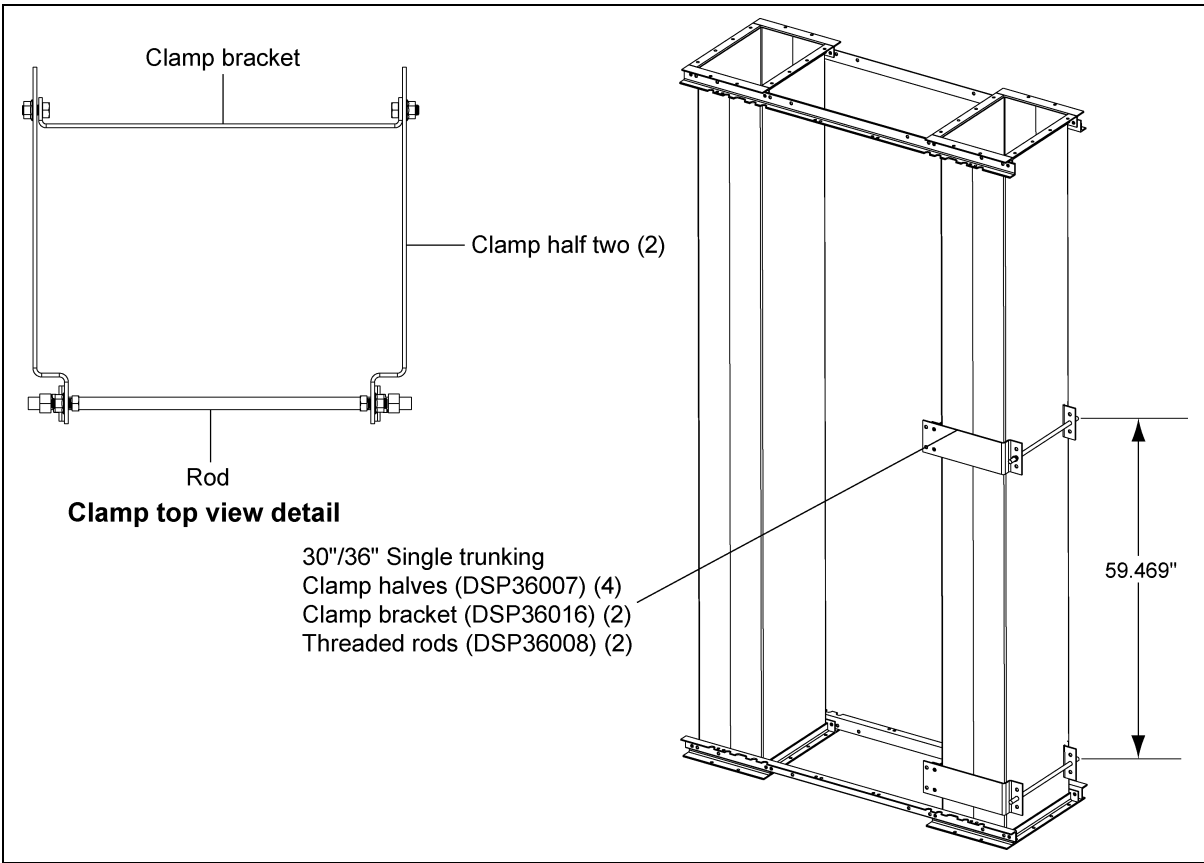

Figure 13A

13. 6 x 6 Distributor Platforms

Support Channels and Knee Braces

Assemble clamps securely to the trunk, attach the platform support channel (DSP36005) to the upper clamp using 1/2" hardware.

Insert rod (DSP36008) through middle hole in the bracket, attached to the platform support channel using 5/8" hex nut (S-4110), 5/8" lock washer (S-3208) and two (2) 5/18" flat washers (S-858). The knee braces will attach in the upper set of holes on side of support channels using 1/2" hardware. (See Figure 13B.)

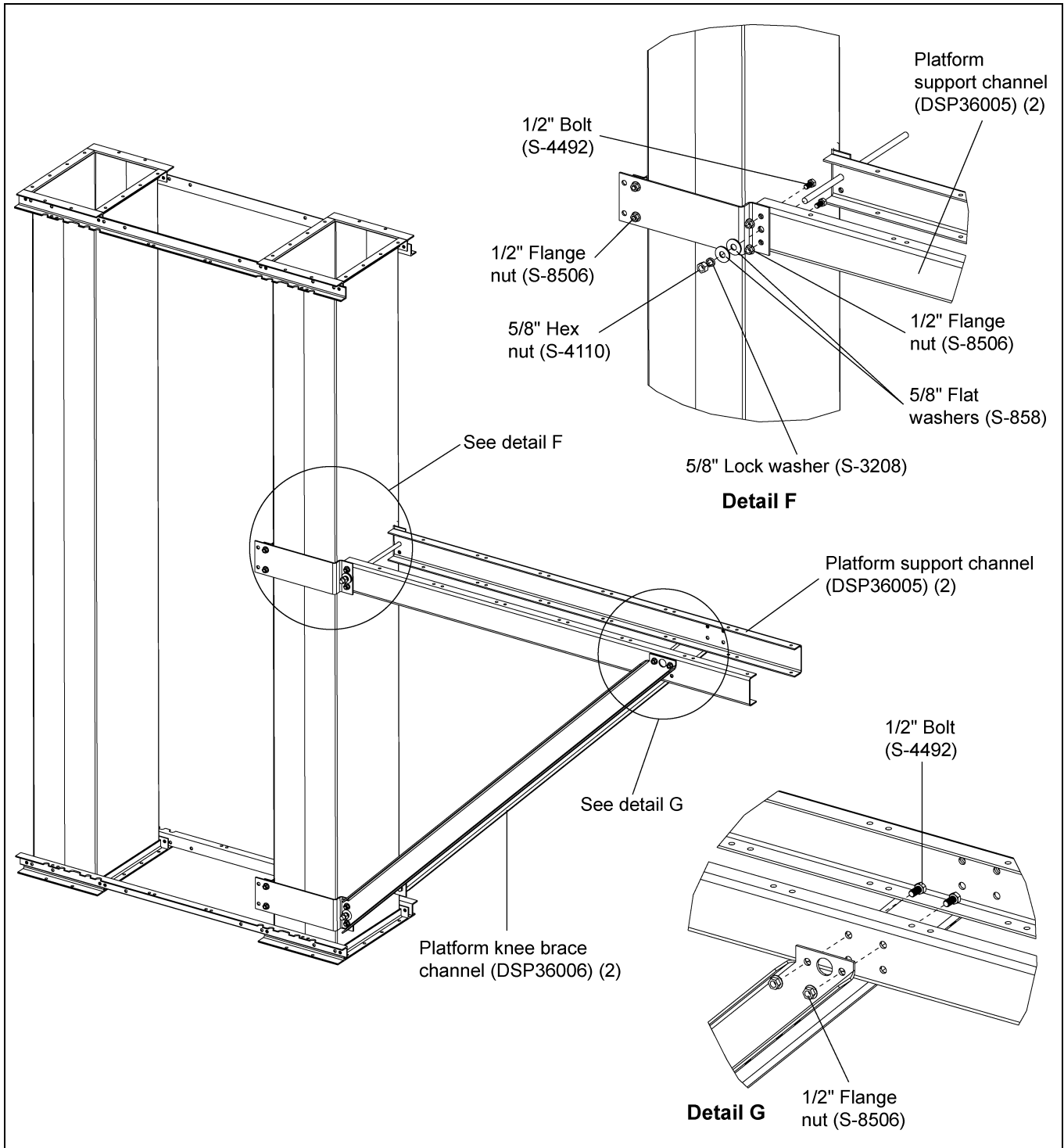

Figure 13B

Toe Boards

With support assembly attached to trunk and hardware tightened, proceed by attaching the notched toe board angle (DSP36002X) and toe board angle (DSP36003X) to the top of the support channel using the 5/16" hardware provided. (Leave hardware loose.) (See Figure 13C.)

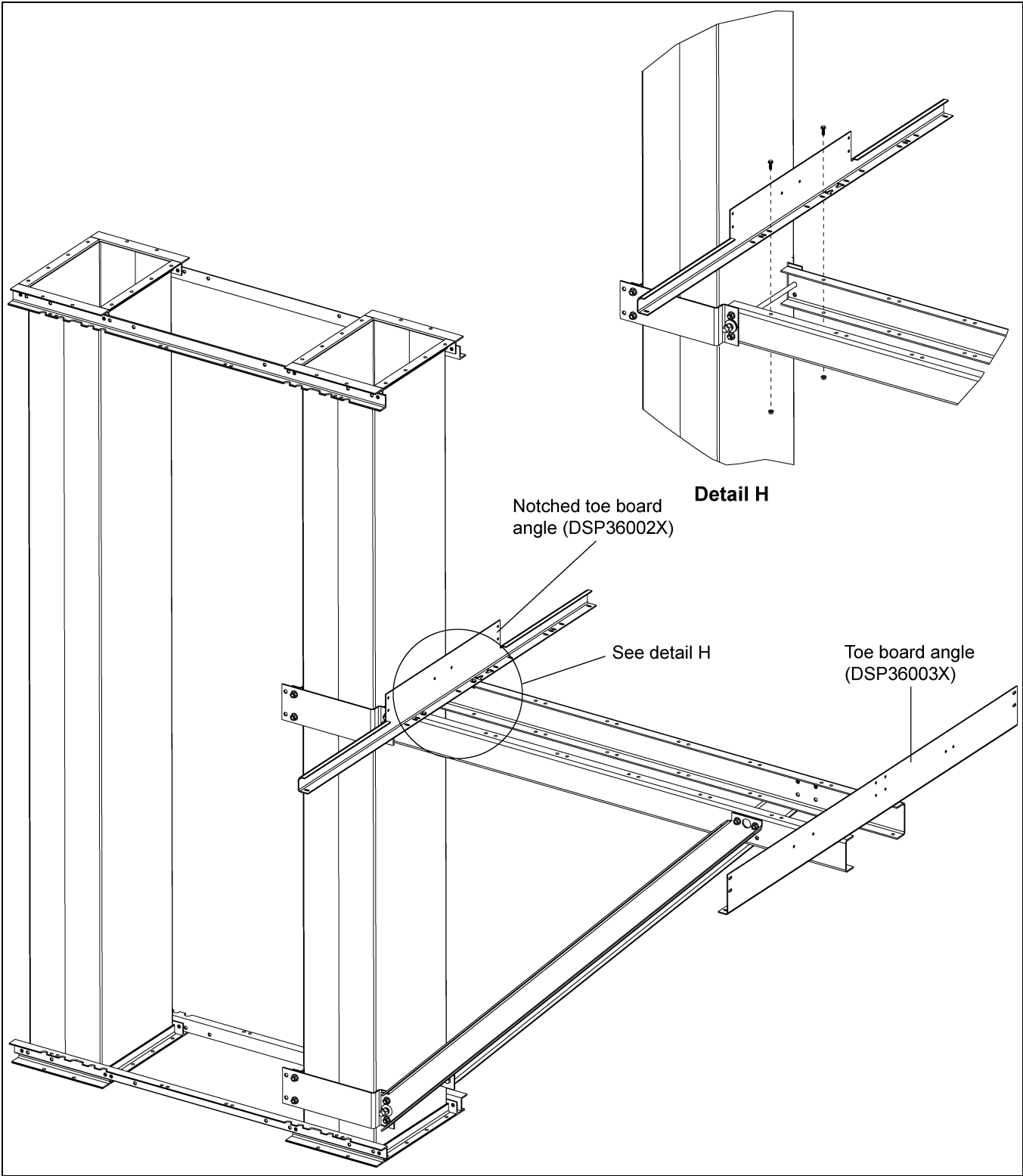

Figure 13C

13. 6 x 6 Distributor Platforms

Cross Braces for Knee Braces

Attach knee brace diagonals to bottom side of the knee braces, this will add extra stability to the distributor platform. (See Figure 13D below and Figure 13E on Page 103.)

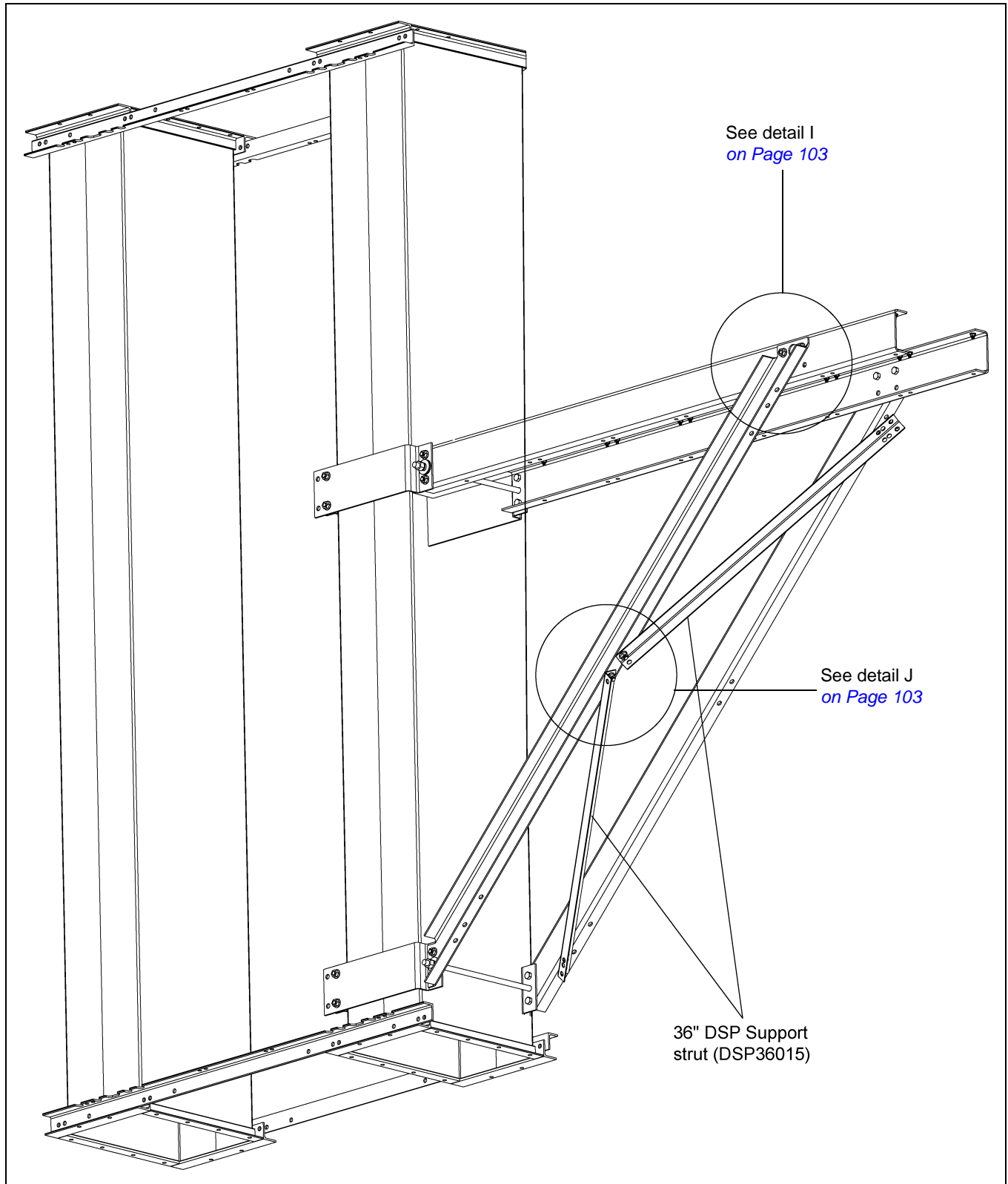

Figure 13D

Cross Braces for Knee Braces (Continued)

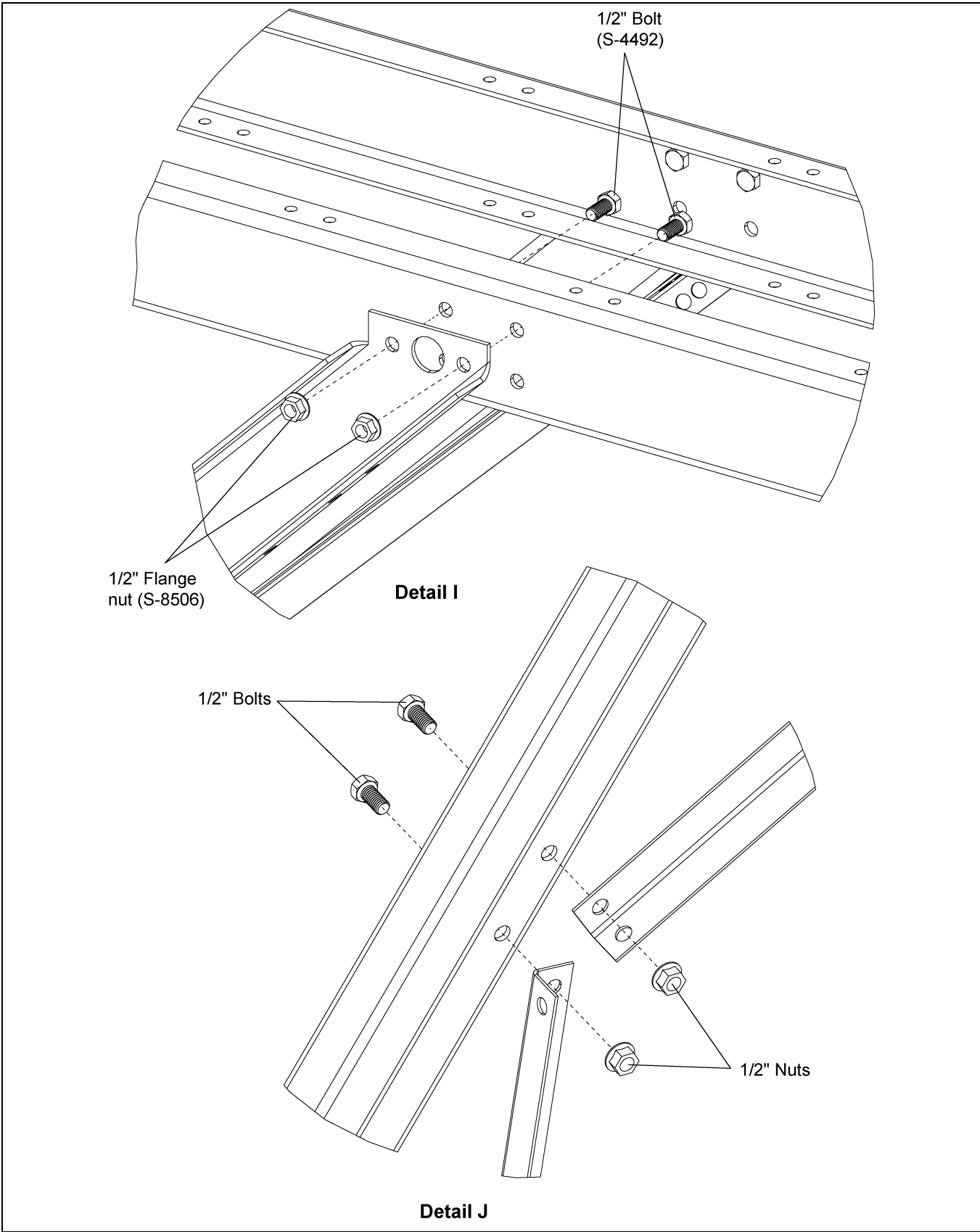

Figure 13E



13. 6 x 6 Distributor Platforms

Platform Decking

Attach the floor deck panels to the support channels. Then attach end toe boards (DSP36000X) to the platform decking (DSP36004) with the 5/16" hardware provided. Add extra toe board plates, after all pieces have been attached and positioned properly, tighten all hardware. (See [Figure 13F below](#) and [Figure 13G on Page 105.](#))

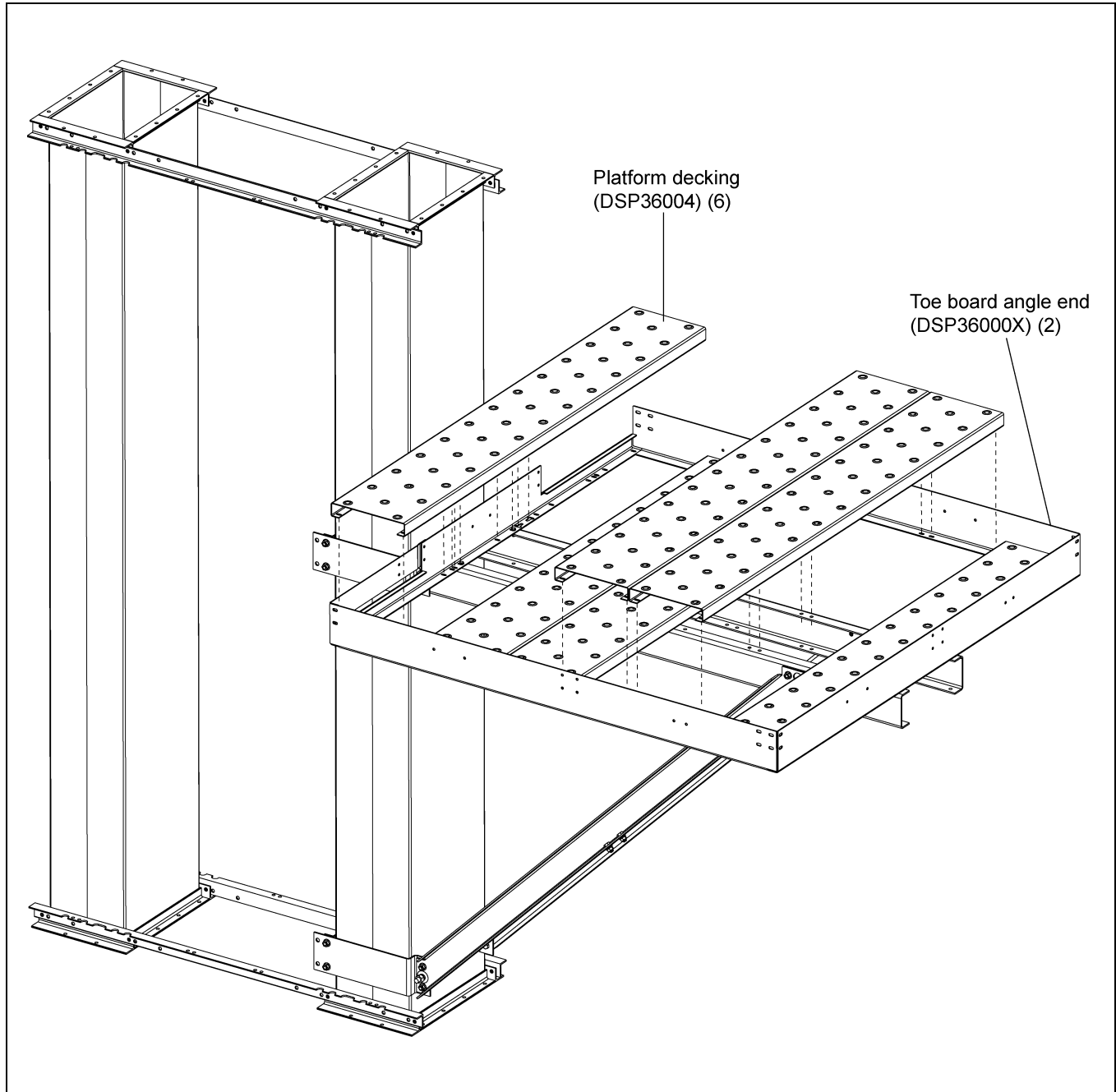

Figure 13F

Platform Decking (Continued)

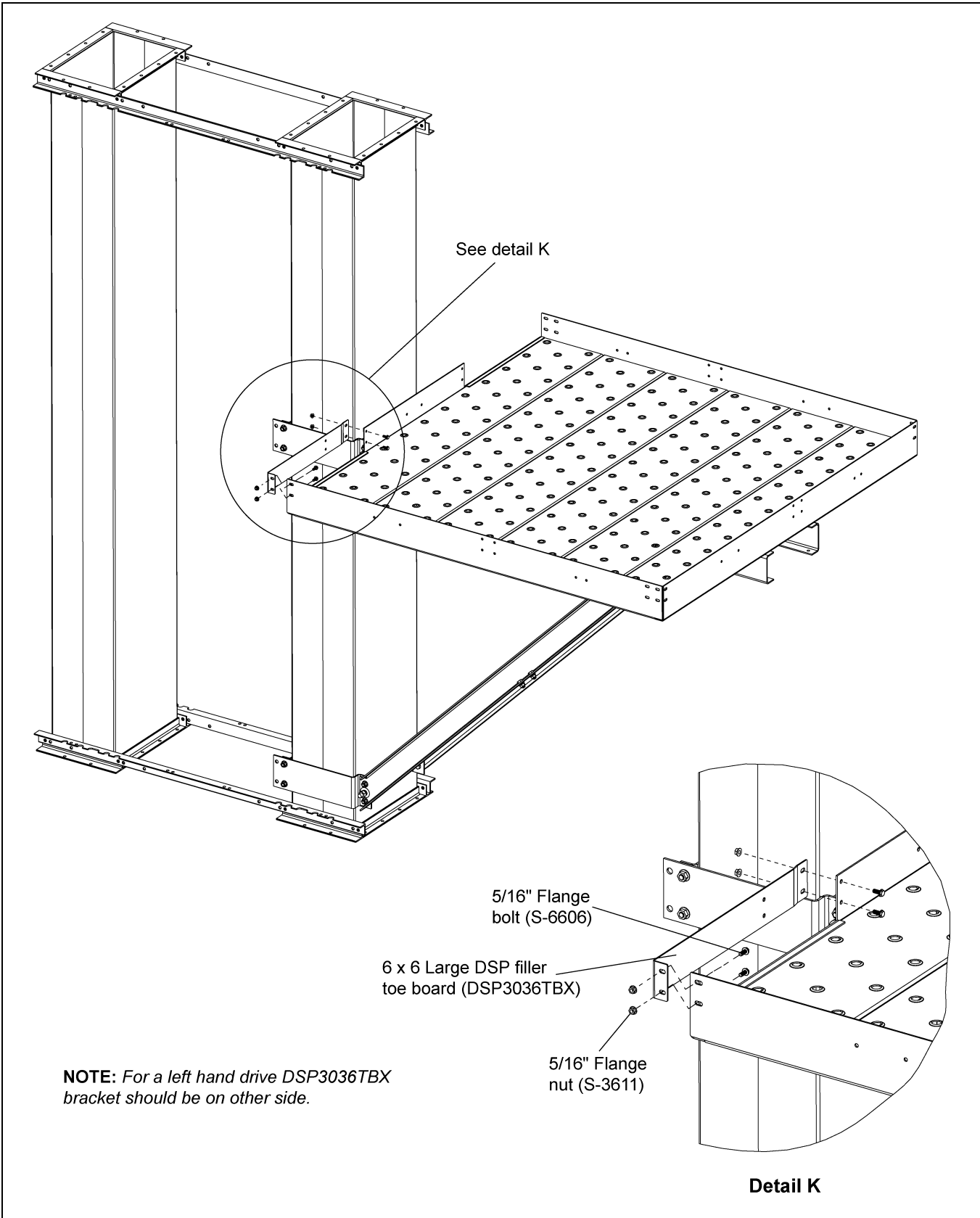

Figure 13G

Platform Post

Figure 13H shows the assembly of three (3) "W" corner posts (HP1648HWP), three (3) platform posts (HP1648HCP) and two (2) safety gate side posts (HP1648HP). This must all be assembled using 5/16" hardware.

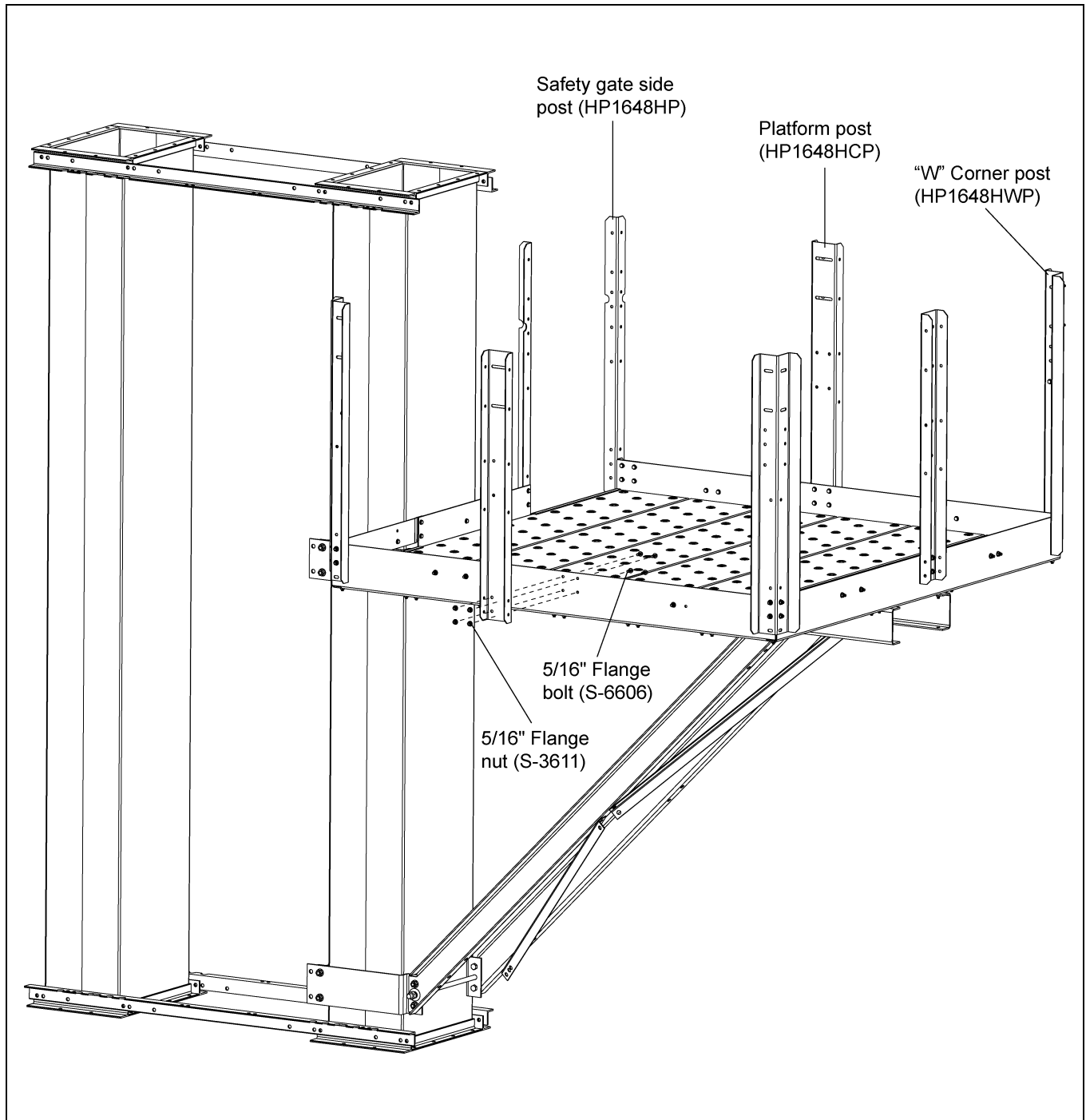

Figure 13H

Tie Braces

IMPORTANT: For safety purposes, make sure head of bolts are to the inside of platform with nuts on outside at all connections.

NOTE: Safety cage bars are used as tie braces in this installation.

Between each of the three (3) "W" corner posts (HP1648HWP), platform post (HP1648HCP) and safety gate side post (HP1648HP), attach two (2) tie braces (safety cage bar (LDR-5171BE)) from the lower half of the post to toe boards using 5/16"-18 x 3/4" ZN grade 5 bolts (S-6606) and 5/16"-18 YDP grade 2 flange nut (S-3611). (See Figure 13I.)

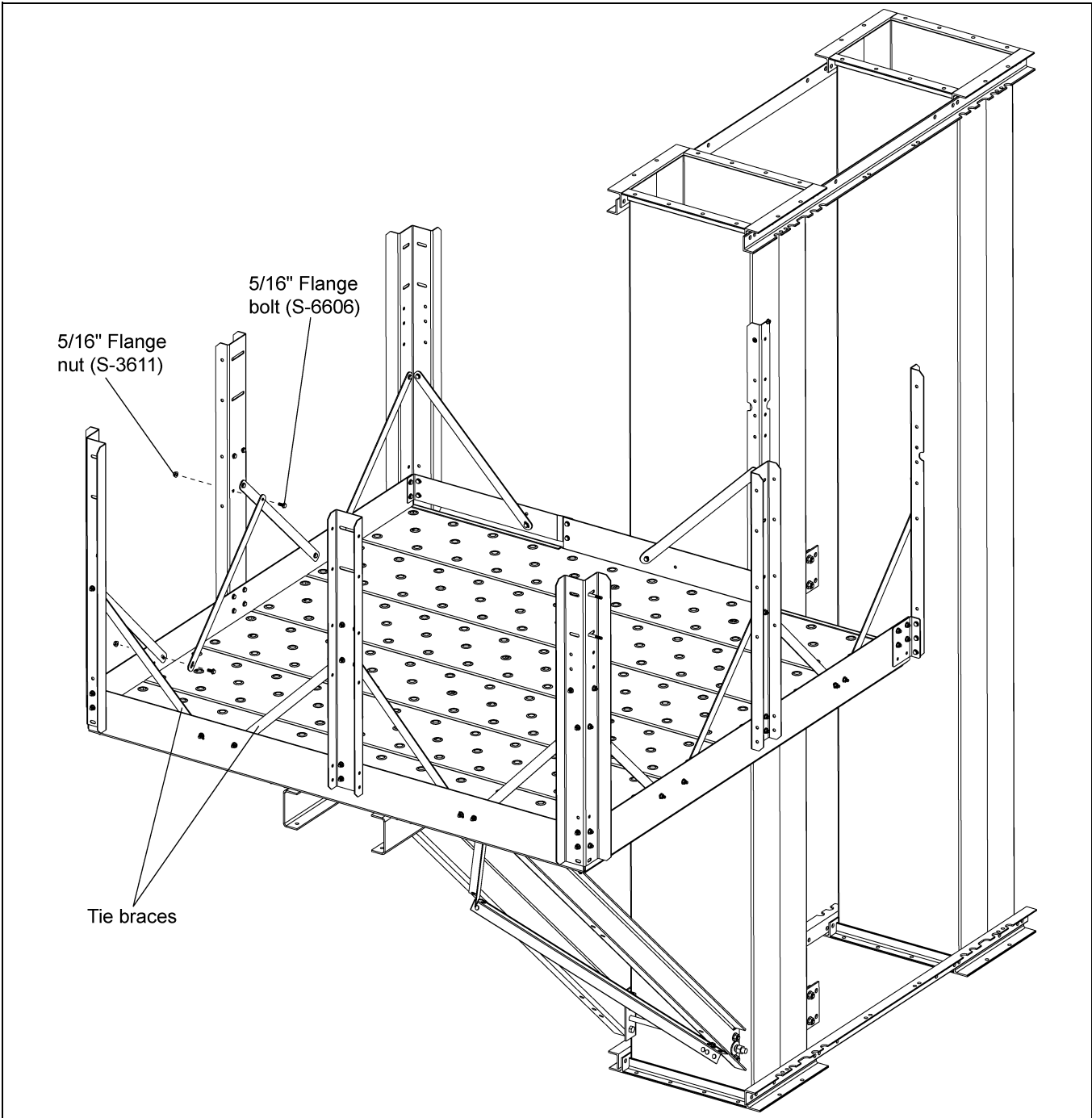

Figure 13I

13. 6 x 6 Distributor Platforms

Intermediate Handrail

IMPORTANT: For safety purposes, make sure head of bolts are to the inside of platform with nuts on outside at all connections.

NOTE: The small intermediate handrail (LDR-4088) fits inside of the large intermediate handrail (LDR-4087). Identify and separate the large and small intermediate handrails.

Trim six (6) large and six (6) small rails by 14" each so that the remaining length of each rail, both small and large is 22". (See Figure 13J.)

1. Install these rails across the platform and the opposite side as shown in Figure 13J.
2. Insert one small rail inside of one large rail and telescope the joined rails from the "W" corner post to the platform post as shown in Figure 13J.
3. Attach to "W" post (corner post) and platform post using nuts (S-3611) and bolts (S-6606). Torque to standard specifications.

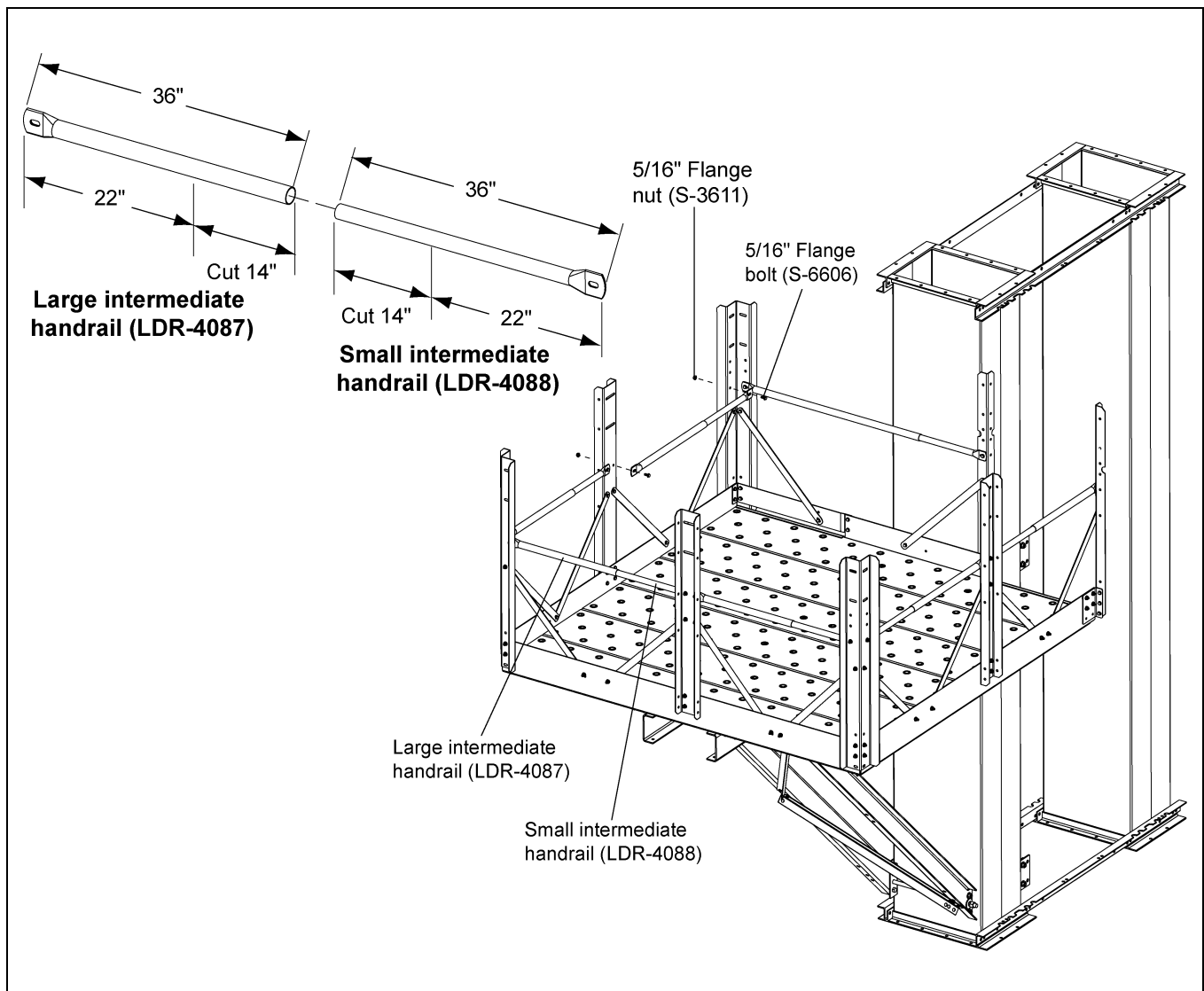

Figure 13J

Upper Handrails

IMPORTANT: For safety purposes, make sure head of bolts are to the inside of platform with nuts on outside at all connections. (See Figure 13K.)

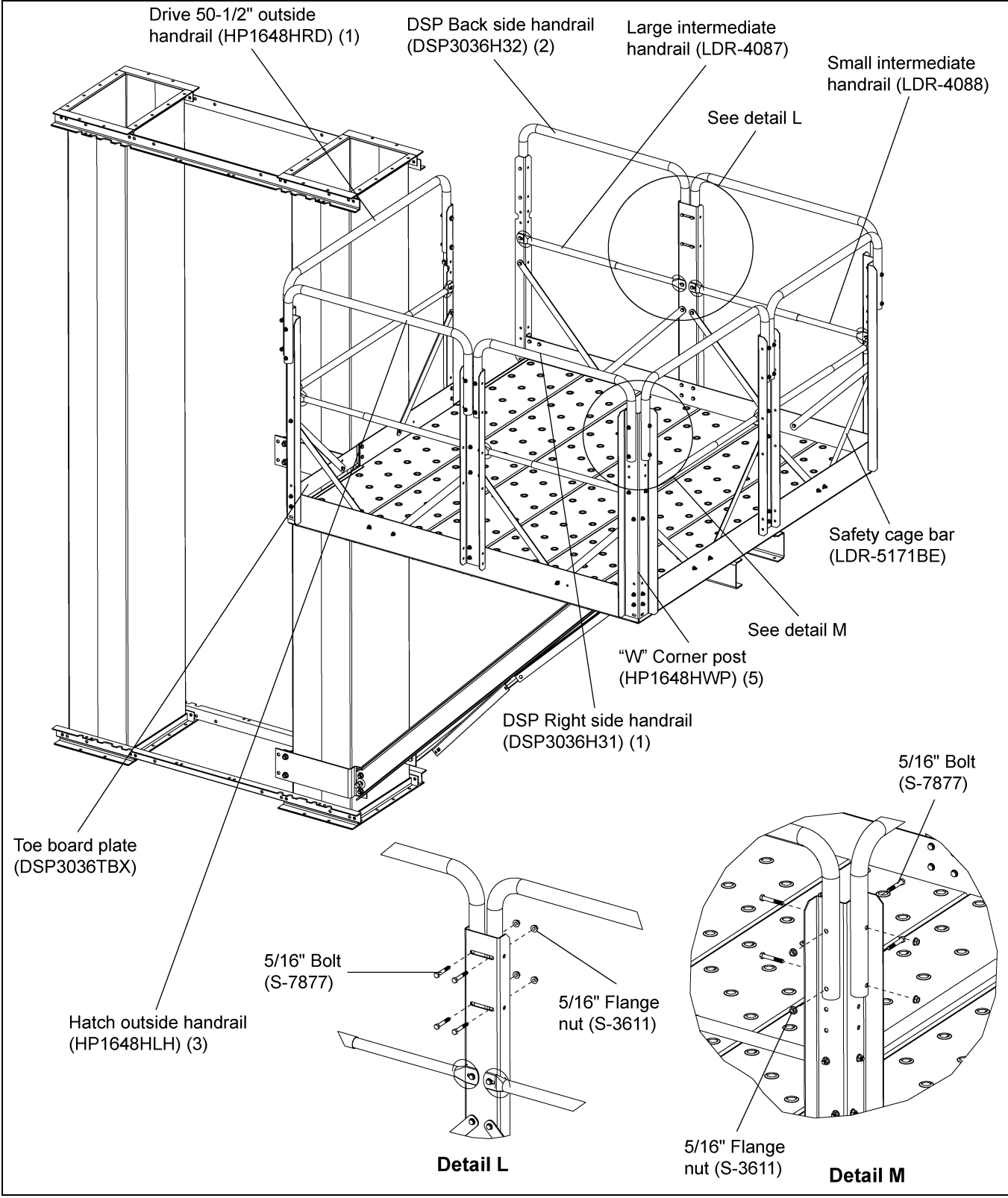

Figure 13K

13. 6 x 6 Distributor Platforms

Upper Handrails (Continued)

Attach hatch outside handrail (HP1648HLH) from "W" corner post to platform post and right side handrail (DSP3036H31) from platform post to next "W" corner post using 5/16" bolt (S-7877) and 5/16" flange nut (S-3611). (See Figure 13L.)

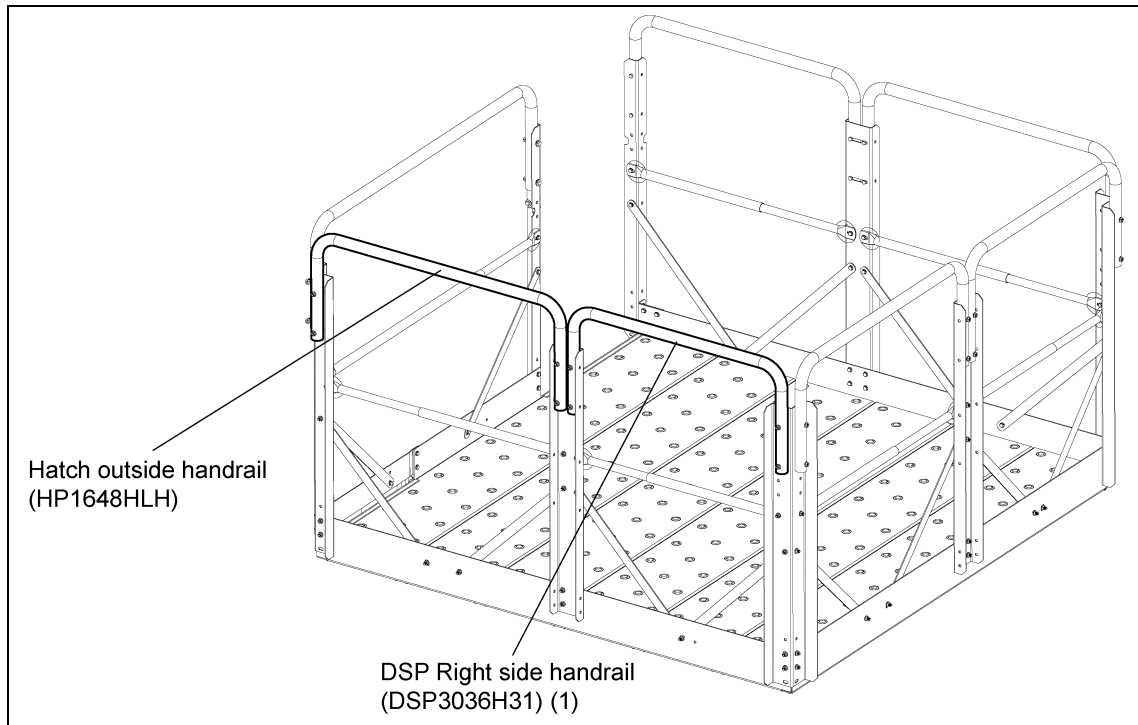

Figure 13L

Attach hatch outside handrail (HP1648HLH) from "W" corner post to platform post and back side handrail (DSP3036H32) from platform post to next "W" corner post using 5/16" bolt (S-7877) and 5/16" flange nut (S-3611). (See Figure 13M.)

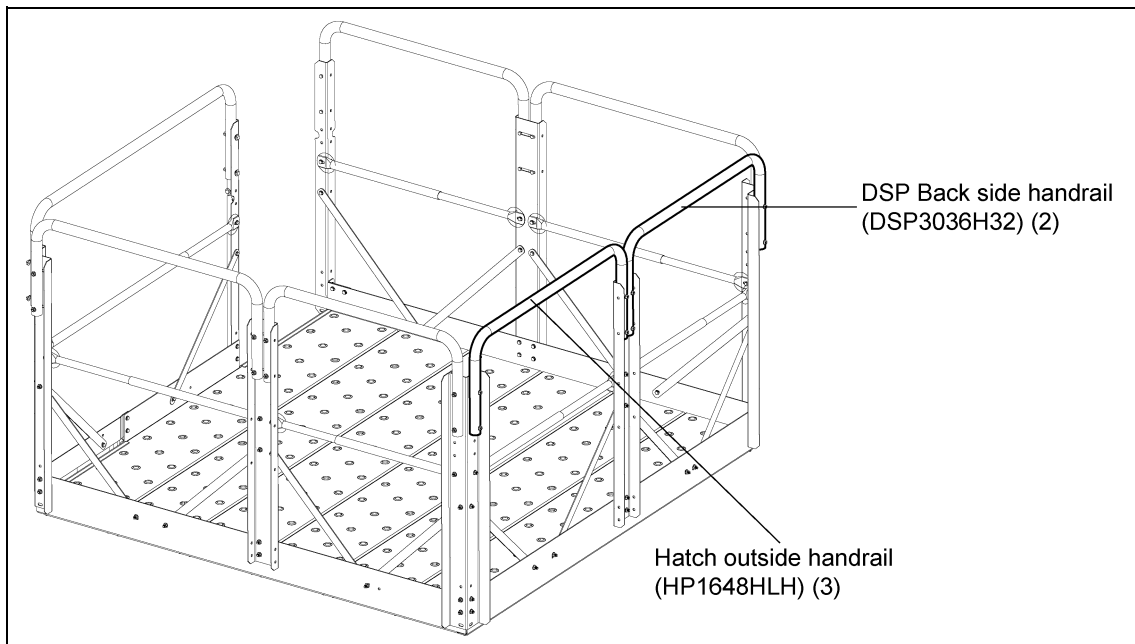

Figure 13M

Upper Handrails (Continued)

Attach hatch outside handrail (HP1648HLH) from "W" corner post to platform post and back side handrail (DSP3036H32) from platform post to next safety gate side post (HP1648HP) using 5/16" bolt (S-7877) and 5/16" flange nut (S-3611). (See Figure 13N.)

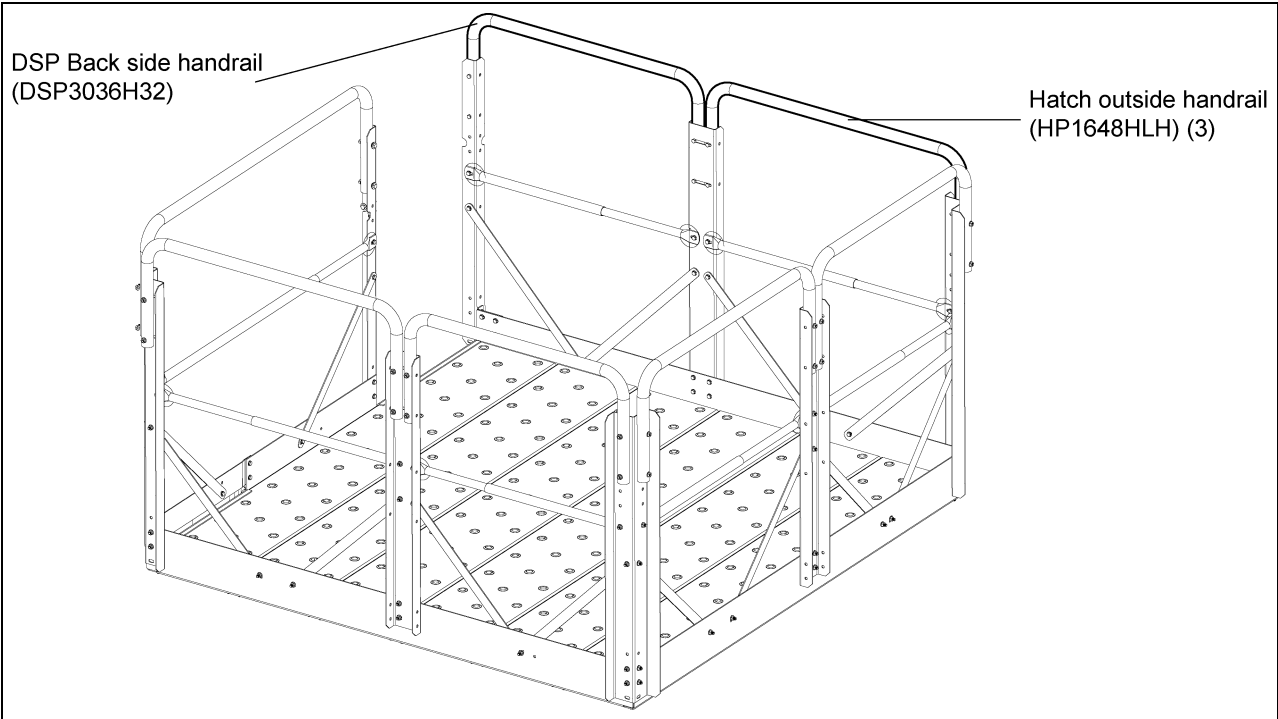

Figure 13N

Attach drive handrail (HP1648HRD) from "W" corner post to safety gate side post (HP1648HP) using 5/16" bolt (S-7877) and 5/16" flange nut (S-3611). (See Figure 13O.)

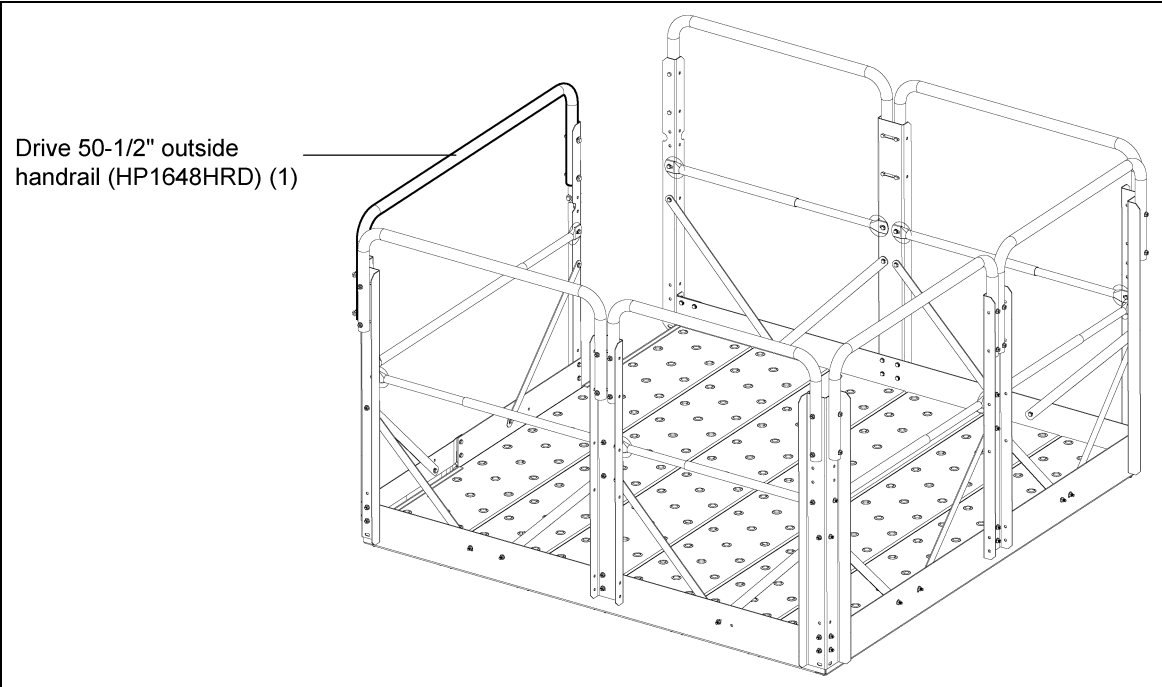

Figure 13O

13. 6 x 6 Distributor Platforms

Safety Gate Package (If Ordered as Optional)

IMPORTANT: Attach the platform gate bracket to the gate before attaching it to the inside platform post using 5/16" hardware.

Attach safety gate assembly to intermediate platform door bracket using 5/16" bolt (S-1196), 5/16" flat washer (S-845) and 5/16" flange nut (S-3611).

Attach intermediate platform door bracket to two (2) safety gate side posts (HP1648HP) using 5/16" bolt (S-1196), 5/16" flat washer (S-845) and 5/16" flange nut (S-3611). (See Figure 13P below and Figure 13Q on Page 113.)

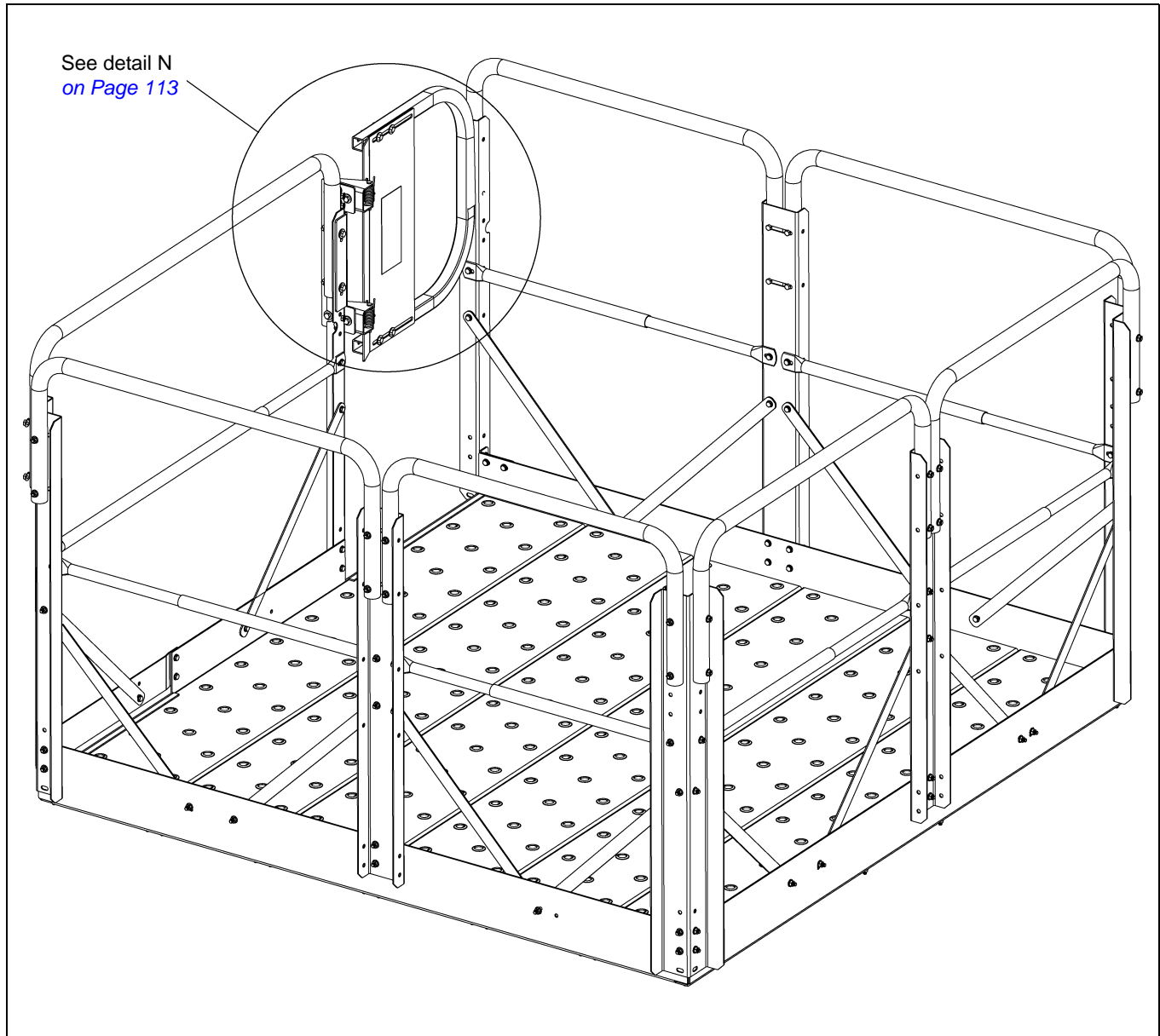

Figure 13P

Safety Gate Package (If Ordered as Optional) (Continued)

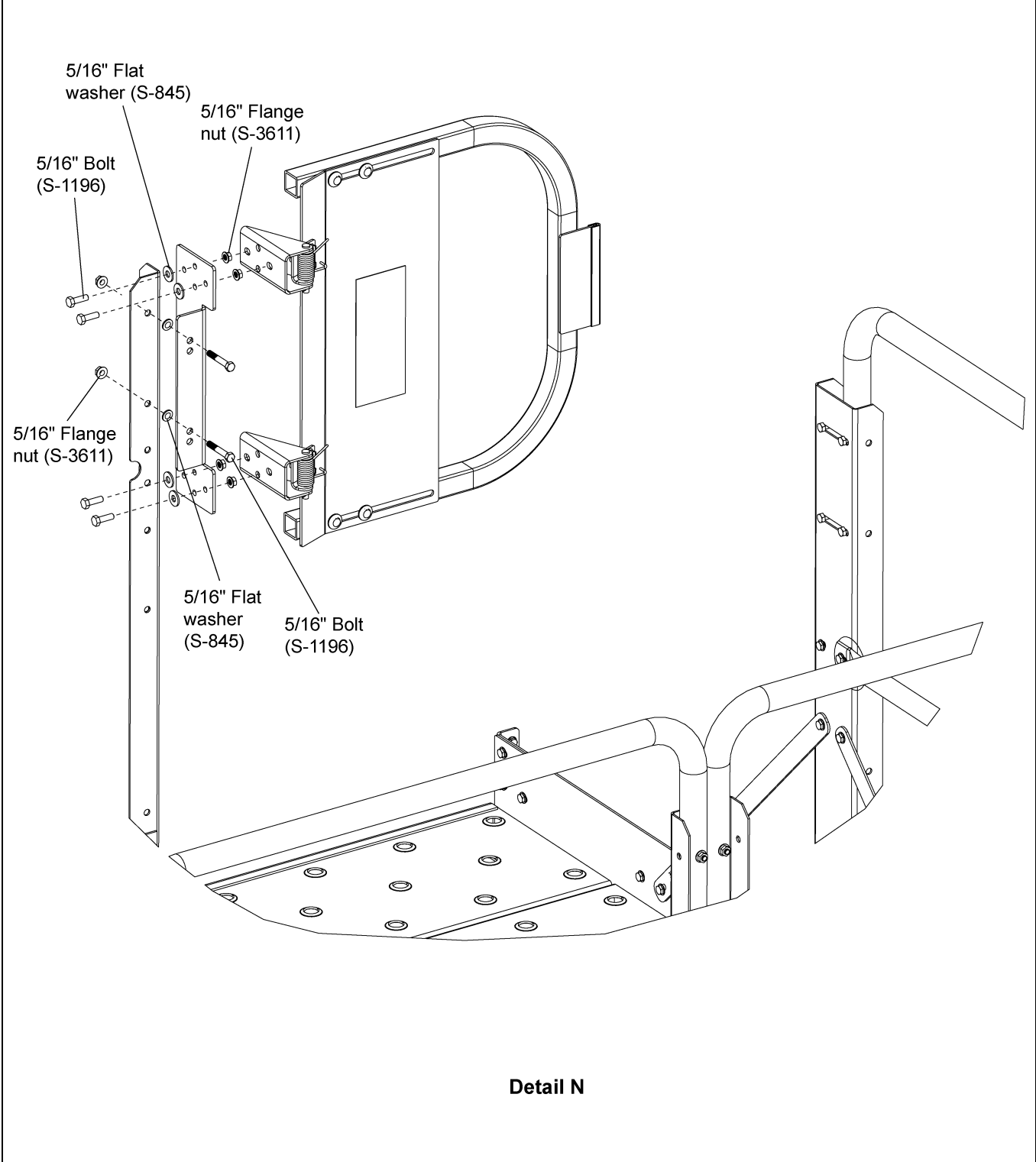

Figure 13Q



NOTES

GSI Group, LLC Limited Warranty

The GSI Group, LLC ("GSI") warrants products which it manufactures to be free of defects in materials and workmanship under normal usage and conditions for a period of 12 months after sale to the original end-user or if a foreign sale, 14 months from arrival at port of discharge, whichever is earlier. The end-user's sole remedy (and GSI's only obligation) is to repair or replace, at GSI's option and expense, products that in GSI's judgment, contain a material defect in materials or workmanship. Expenses incurred by or on behalf of the end-user without prior written authorization from the GSI Warranty Group shall be the sole responsibility of the end-user.

Warranty Extensions:

The Limited Warranty period is extended for the following products:

	Product	Warranty Period	
AP Fans and Flooring	Performer Series Direct Drive Fan Motor	3 Years	* Warranty prorated from list price: 0 to 3 years - no cost to end-user 3 to 5 years - end-user pays 25% 5 to 7 years - end-user pays 50% 7 to 10 years - end-user pays 75%
	All Fiberglass Housings	Lifetime	
	All Fiberglass Propellers	Lifetime	
Cumberland Feeding/Watering Systems	Feeder System Pan Assemblies	5 Years **	** Warranty prorated from list price: 0 to 3 years - no cost to end-user 3 to 5 years - end-user pays 50%
	Feed Tubes (1-3/4" and 2.00")	10 Years *	
	Centerless Augers	10 Years *	
	Watering Nipples	10 Years *	
Grain Systems	Grain Bin Structural Design	5 Years	† Motors, burner components and moving parts not included. Portable dryer screens included. Tower dryer screens not included.
Grain Systems Farm Fans Zimmerman	Portable and Tower Dryers	2 Years	
	Portable and Tower Dryer Frames and Internal Infrastructure †	5 Years	

GSI further warrants that the portable and tower dryer frame and basket, excluding all auger and auger drive components, shall be free from defects in materials for a period of time beginning on the twelfth (12th) month from the date of purchase and continuing until the sixtieth (60th) month from the date of purchase (extended warranty period). During the extended warranty period, GSI will replace the frame or basket components that prove to be defective under normal conditions of use without charge, excluding the labor, transportation, and/or shipping costs incurred in the performance of this extended warranty.

Conditions and Limitations:

THERE ARE NO WARRANTIES THAT EXTEND BEYOND THE LIMITED WARRANTY DESCRIPTION SET FORTH ABOVE. SPECIFICALLY, GSI MAKES NO FURTHER WARRANTY OF ANY KIND, EXPRESS OR IMPLIED, INCLUDING, WITHOUT LIMITATION, WARRANTIES OF MERCHANTABILITY OR FITNESS FOR A PARTICULAR PURPOSE OR USE IN CONNECTION WITH: (I) PRODUCT MANUFACTURED OR SOLD BY GSI OR (II) ANY ADVICE, INSTRUCTION, RECOMMENDATION OR SUGGESTION PROVIDED BY AN AGENT, REPRESENTATIVE OR EMPLOYEE OF GSI REGARDING OR RELATED TO THE CONFIGURATION, INSTALLATION, LAYOUT, SUITABILITY FOR A PARTICULAR PURPOSE, OR DESIGN OF SUCH PRODUCTS.

GSI shall not be liable for any direct, indirect, incidental or consequential damages, including, without limitation, loss of anticipated profits or benefits. The sole and exclusive remedy is set forth in the Limited Warranty, which shall not exceed the amount paid for the product purchased. This warranty is not transferable and applies only to the original end-user. GSI shall have no obligation or responsibility for any representations or warranties made by or on behalf of any dealer, agent or distributor.

GSI assumes no responsibility for claims resulting from construction defects or unauthorized modifications to products which it manufactured. Modifications to products not specifically delineated in the manual accompanying the equipment at initial sale will void the Limited Warranty.

This Limited Warranty shall not extend to products or parts which have been damaged by negligent use, misuse, alteration, accident or which have been improperly/inadequately maintained. This Limited Warranty extends solely to products manufactured by GSI.

Prior to installation, the end-user has the responsibility to comply with federal, state and local codes which apply to the location and installation of products manufactured or sold by GSI.

This equipment shall be installed in accordance with the current installation codes and applicable regulations, which should be carefully followed in all cases. Authorities having jurisdiction should be consulted before installations are made.

G S I G R O U P



GSI Group
1004 E. Illinois St.
Assumption, IL 62510-0020
Phone: 1-217-226-4421
Fax: 1-217-226-4420
www.gsiag.com