

Farm/Commercial Distributor Cable Control

Installation Manual

PNEG-1375

Version: 2.1

Date: **12-21-20**



PNEG-1375

Equipment Information

Use of the equipment information page will help you identify the equipment in the case that you need call your dealer or installer. This information should be filled out and kept on record.

Model #: _____

Date Purchased: _____

Serial #: _____

Dealer Name and Phone #: _____

RPM: _____

Head Pulley Diameter: _____

Discharge Height: _____

Horsepower: _____

Spout Diameter: _____

of Spouts: _____

All information, illustrations, photos, and specifications in this manual are based on the latest information available at the time of publication. The right is reserved to make changes at any time without notice.

Contents

Chapter 1 Introduction	4
Chapter 2 Safety	5
Safety Guidelines	5
Safety Instructions	6
Operator Qualifications	8
Chapter 3 Decals	9
Decal Locations	9
Chapter 4 Part Identification	10
Chapter 5 Installation	11
Installation of Cable Wheel and Coupler Connector	11
Connector Pulley Assembly	12
Cable Guide Location	13
Upper Cable Guide Assembly	14
Control Handle Installation	15
Lower Cable Wheel Assembly	16
Cable Guides	17
Cable Installation	18
Calibrating the Distributor Spout and the Lower Cable Control Wheel	22
Chapter 6 Warranty	23

1. Introduction

Thank you for choosing this product. It is designed to give excellent performance and service for many years.

This manual covers general information on the distributor cable control installation. Due to the wide variety of field conditions we cannot cover every aspect of installation. We offer one method for installing equipment but, rely on the qualified contractor's experience and techniques. Some conditions and surroundings do not allow certain practices during the installation of equipment. We cannot be responsible for the installation of the distributor and accessories. We encourage anyone installing or maintaining this equipment to thoroughly read this manual before proceeding.

The company is the vendor of the distributor and certain of its optional accessories only and does not assume responsibility for the installation. The installation recommendations contained within this manual are for consideration only.

READ THIS MANUAL carefully to learn how to properly use and install equipment. Failure to do so could result in personal injury or equipment damage.

INSPECT the shipment immediately upon arrival. The customer is responsible for ensuring that all quantities are correct. The customer should report and note any damage or shortage on the bill of lading to justify their claim to the transport company.

THIS MANUAL SHOULD BE CONSIDERED a permanent part of your equipment and should be easily accessible when needed.

This warranty provides you the assurance that the company will back its products when defects appear within the warranty period. In some circumstances, the company also provides field improvements, often without charge to the customer, even if the product is out of warranty. Should the equipment be abused, or modified to change its performance beyond the factory specifications, the warranty will become void and field improvements may be denied.

Safety Guidelines

This manual contains information that is important for you, the owner/operator, to know and understand. This information relates to protecting **personal safety** and **preventing equipment problems**. It is the responsibility of the owner/operator to inform anyone operating or working in the area of this equipment of these safety guidelines. To help you recognize this information, we use the symbols that are defined below. Please read the manual and pay attention to these sections. Failure to read this manual and its safety instructions is a misuse of the equipment and may lead to serious injury or death.



This is the safety alert symbol. It is used to alert you to potential personal injury hazards. Obey all safety messages that follow this symbol to avoid possible injury or death.



This symbol indicates an imminently hazardous situation which, if not avoided, **will result in serious injury or death**.



This symbol indicates a potentially hazardous situation which, if not avoided, **may result in serious injury or death**.



This symbol indicates a potentially hazardous situation which, if not avoided, **may result in minor or moderate injury**.



This symbol indicates a potentially hazardous situation which, if not avoided, **may result in property damage**.

2. Safety

Safety Instructions

Our foremost concern is your safety and the safety of others associated with this equipment. We want to keep you as a customer. This manual is to help you understand safe operating procedures and some problems that may be encountered by the operator and other personnel.

As owner and/or operator, it is your responsibility to know what requirements, hazards, and precautions exist, and to inform all personnel associated with the equipment or in the area. Safety precautions may be required from the personnel. Avoid any alterations to the equipment. Such alterations may produce a very dangerous situation, where **SERIOUS INJURY** or **DEATH** may occur.

This equipment shall be installed in accordance with the current installation codes and applicable regulations, which should be carefully followed in all cases. Authorities having jurisdiction should be consulted before installations are made.

Follow Safety Instructions

Carefully read all safety messages in this manual and safety signs on your machine. Keep signs in good condition. Replace missing or damaged safety signs. Be sure new equipment components and repair parts include the current safety signs. Replacement safety signs are available from the manufacturer.

Learn how to operate the machine and how to use controls properly. Do not let anyone operate without instruction.

Keep your machinery in proper working condition. Unauthorized modifications to the machine may impair the function and/or safety and affect machine life.

If you do not understand any part of this manual or need assistance, contact your dealer.

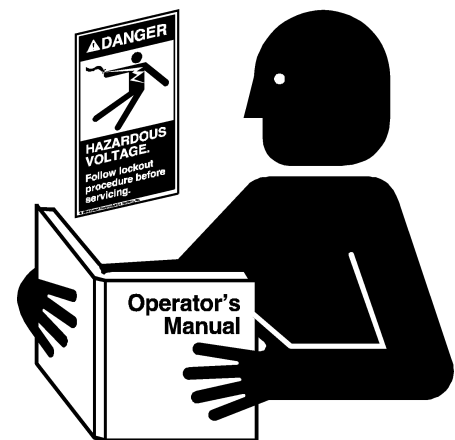

Read and Understand Manual

Prepare for Emergencies

Be prepared if fire starts.

Keep a first aid kit and fire extinguisher handy.

Keep emergency numbers for doctors, ambulance service, hospital, and fire department near your telephone.

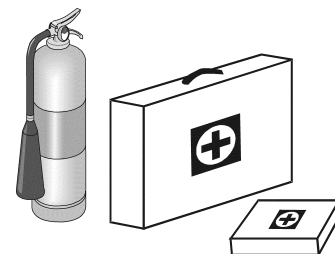

Keep Emergency Equipment Quickly Accessible

Wear Protective Clothing

Wear close-fitting clothing and safety equipment appropriate to the job.

Remove all jewelry.

Tie long hair up and back.

Wear safety glasses at all times to protect eyes from debris.

Wear gloves to protect your hands from sharp edges on plastic or steel parts.

Wear steel-toed boots to help protect your feet from falling debris. Tuck in any loose or dangling shoestrings.

A respirator may be needed to prevent breathing potentially toxic fumes and dust.

Wear a hard hat to help protect your head.

Wear appropriate fall protection equipment when working at elevations greater than six feet (6').

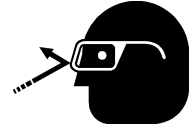
Eye Protection**Gloves****Steel-Toed Boots****Respirator****Hard Hat****Fall Protection**

Operator Qualifications

- A. The User/Operator must be competent and experienced to operate auger equipment. Anyone who works with or around augers must have good common sense in order to be qualified. These persons must also know and meet all other qualifications, such as:
- i. Any person who has not read and/or does not understand all operation and safety procedures is not qualified to operate any auger systems.
 - ii. Certain regulations apply to personnel operating power machinery. Personnel under the age of 18 years may not operate power machinery, including augers. It is your responsibility, as owner and/or supervisor, to know what these regulations are in your area or situation.
 - iii. Unqualified or incompetent persons are to remain out of the work area.
 - iv. O.S.H.A. (Occupational Safety and Health Administration) regulations state: "At the time of initial assignment and at least annually thereafter, the employer shall instruct every employee in the safe operation and servicing of all equipment with which the employee is, or will be involved". (Federal Occupational Safety and Health Standards for Agriculture. Subpart D, Section 1928.57 (a) (6)).
- B. As a requirement of O.S.H.A., it is necessary for the employer to train the employee in the safe operating and safety procedures for this auger. The sign-off sheet is provided for your convenience and personal record keeping. All unqualified persons are to stay out of the work area at all times. It is strongly recommended that another qualified person who knows the shut down procedure is in the area in the event of an emergency.

<i>Date</i>	<i>Employee Name</i>	<i>Supervisor Name</i>

Decal Locations

Install safety decals on components as *shown below*. Always ensure that safety decals are in place and in good condition. If a decal cannot be easily read for any reason or has been painted over, replace it immediately. Contact your dealer or the manufacturer to order a replacement decal free of charge.

GSI Decals

1004 E. Illinois St.
Assumption, IL. 62510
Phone: 1-217-226-4421



DC-857

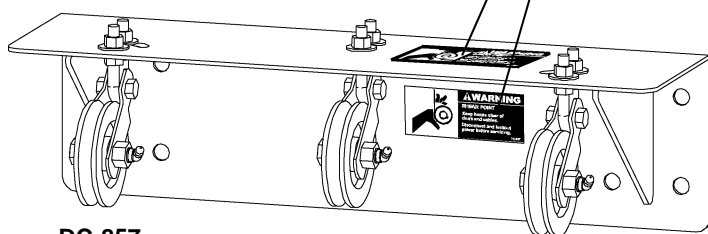

DC-857

Located on the cable guide assembly (DFB0388).

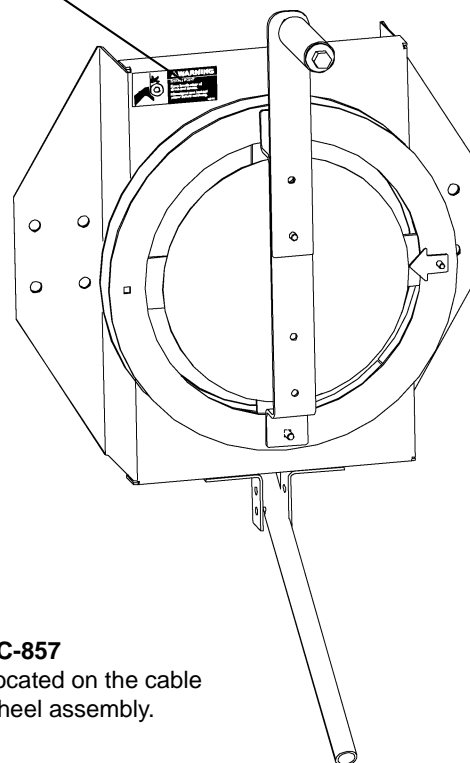

DC-857

Located on the cable wheel assembly.

4. Part Identification

NOTE: Cable is not supplied with cable control. 3/16" Aircraft cable is recommended.

Distributor Cable Control Farm/Commercial

DCC-STD		
Part #	Description	Qty
1636DCG	Trunk Clamp Assembly 16"-36" Platform	2
B24C	Drive Crate, 24" Inside Cube	1
DFB0388	HD Cable Guide Assembly Top	1
FC-DCG-HDW	Hardware, Distributor Cable Guide F/C	1
GSB-0006	Spacer, Bottom Guide	1
GSB-0030	Control Handle	1
GSB-0031	Control Handle Bracket	2
GSB-0045	Connector - Pulley Assembly	1
GSB-0049	Cable Wheel Assembly, Bottom	1
GSB-0061	Cable Wheel Weldment - Farm/Commercial	1

DCC-XL		
Part #	Description	Qty
1636DCG	Trunk Clamp Assembly 16"-36" Platform	2
B42C	Drive Crate, 42" x 40" x 24" "T" I.D.	1
DFB0388	HD Cable Guide Assembly Top	1
DFB0406	XL Cable Wheel Assembly, Bottom	1
DFB0407	XL Control Handle Bracket	2
FC-DCG-HDW	Hardware, Distributor Cable Guide F/C	1
GSB-0006	Spacer, Bottom Guide	1
GSB-0030	Control Handle	1
GSB-0045	Connector - Pulley Assembly	1
DFB0389	XL Cable Wheel Weldment, Top	1

Cable Control Hardware

FC-DCG-HDW		
Part #	Description	Qty
S-8762	Clamp 3/16" Cable Zinc Plated	8
S-7521	Bolt, HHCS 3/8"-16 x 1-1/2" ZN Grade 2	3
S-968	Flange Nut 3/8"-16 ZN Grade 5 Wide Flange	3
S-1146	Bolt, HHCS 5/16"-18 x 1" ZN Grade 2	6
S-10268	Flange Nut 5/16"-18 JS500 Grade 5	6
S-3729	Hex Nut 1/2"-13 ZN YDP Grade 5	20
S-7329	Bolt, HHCS 5/16"-18 x 2" ZN Grade 2	1
S-7382	Nylock Nut 5/16"-18 ZN Grade 5	1
S-8268	Bolt, HHCS 1/2"-13 x 2" ZN Grade 8	16

16"-36" Bucket Elevator

1636 DCG		
Part #	Description	Qty
DSP16002	Clamp Band, 4 x 5 Platform	4
DSP16005	Clamp Rod Weldment, 4 x 5 Platform	2

Installation of Cable Wheel and Coupler Connector

Once the distributor has been installed, the cable controls can be installed. First, install the cable wheel. The cable wheel (B) mounts to the control pipe (A) coming from the bottom of the distributor using three (3) 3/8"-16 x 1-1/2" bolts (S-7521) and three (3) 3/8"-16 flange nuts (S-968). (See Figure 5A.)

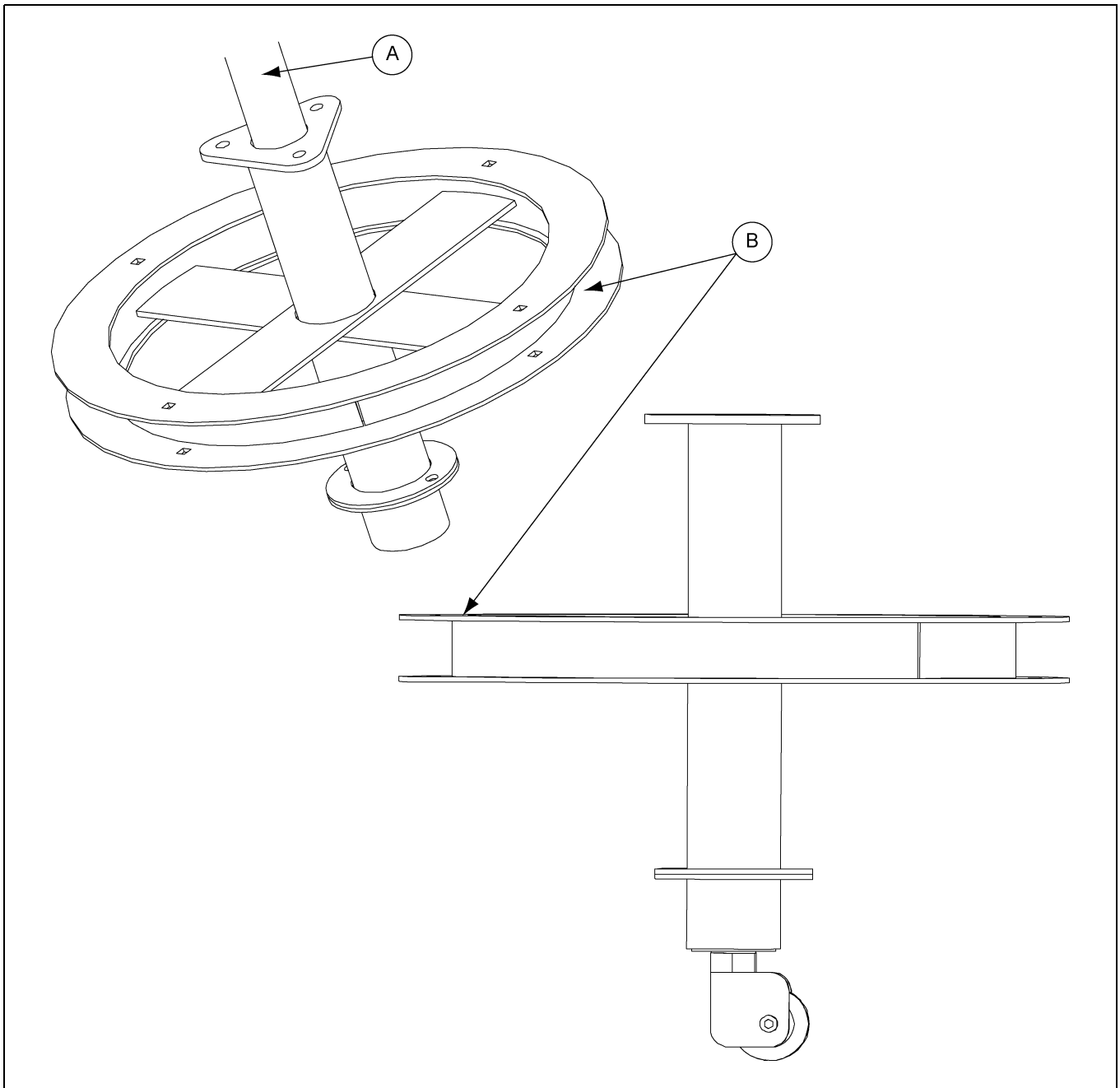

Figure 5A

Ref #	Part #	Description
A		Distributor Control Pipe
B	GSB-0061 DFB0389	Cable Wheel Weldment (For 6" and 8" Distributors) (For 10", 12" and 14" Distributors)

5. Installation

Connector Pulley Assembly

The next piece to install is the connector pulley assembly (C). This piece mounts to the top cable wheel weldment (B) as shown in [Figure 5B](#). These are fastened together using two (2) 5/16" x 1" bolts and nuts, supplied in the hardware package (FC-DCG-HDW).

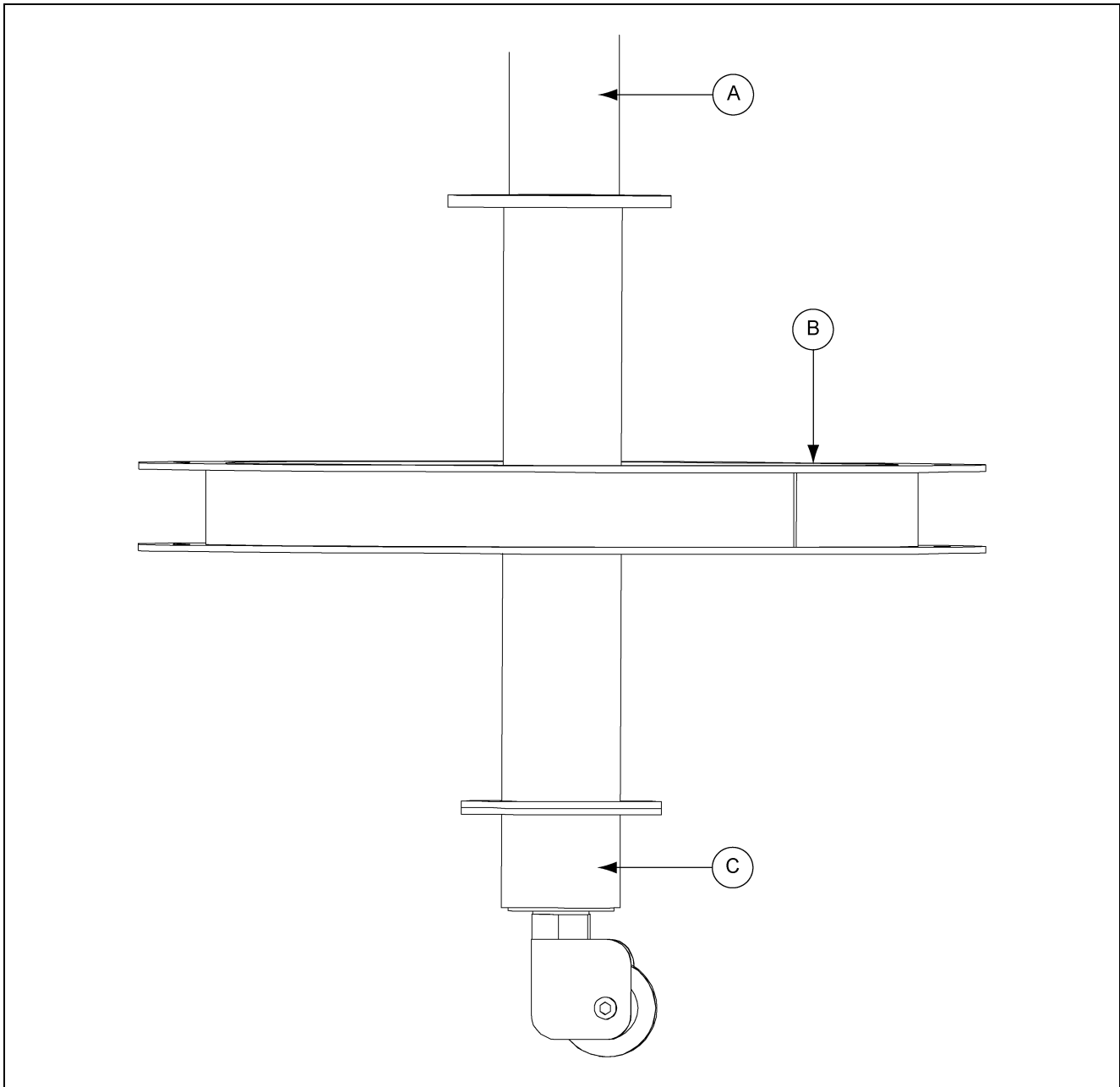

Figure 5B

Ref #	Ref #	Description
A		Distributor Pipe Control
B	GSB-0061 DFB0389	Top Cable Wheel Weldment (For 6" and 8" Distributors) (For 10", 12" and 14" Distributors)
C	GSB-0045	Connector Pulley Assembly

Cable Guide Location

Next locate the upper cable guide assembly (D). The location on the trunking is determined by the height of the cable wheel. The cable must run in-line from the cable wheel to the sheaves in the cable guide assembly. This location is shown in [Figure 5C](#). For cable installation, [See Page 18](#).

NOTE: Cable is not supplied with cable control. The company recommends 3/16" aircraft cable.

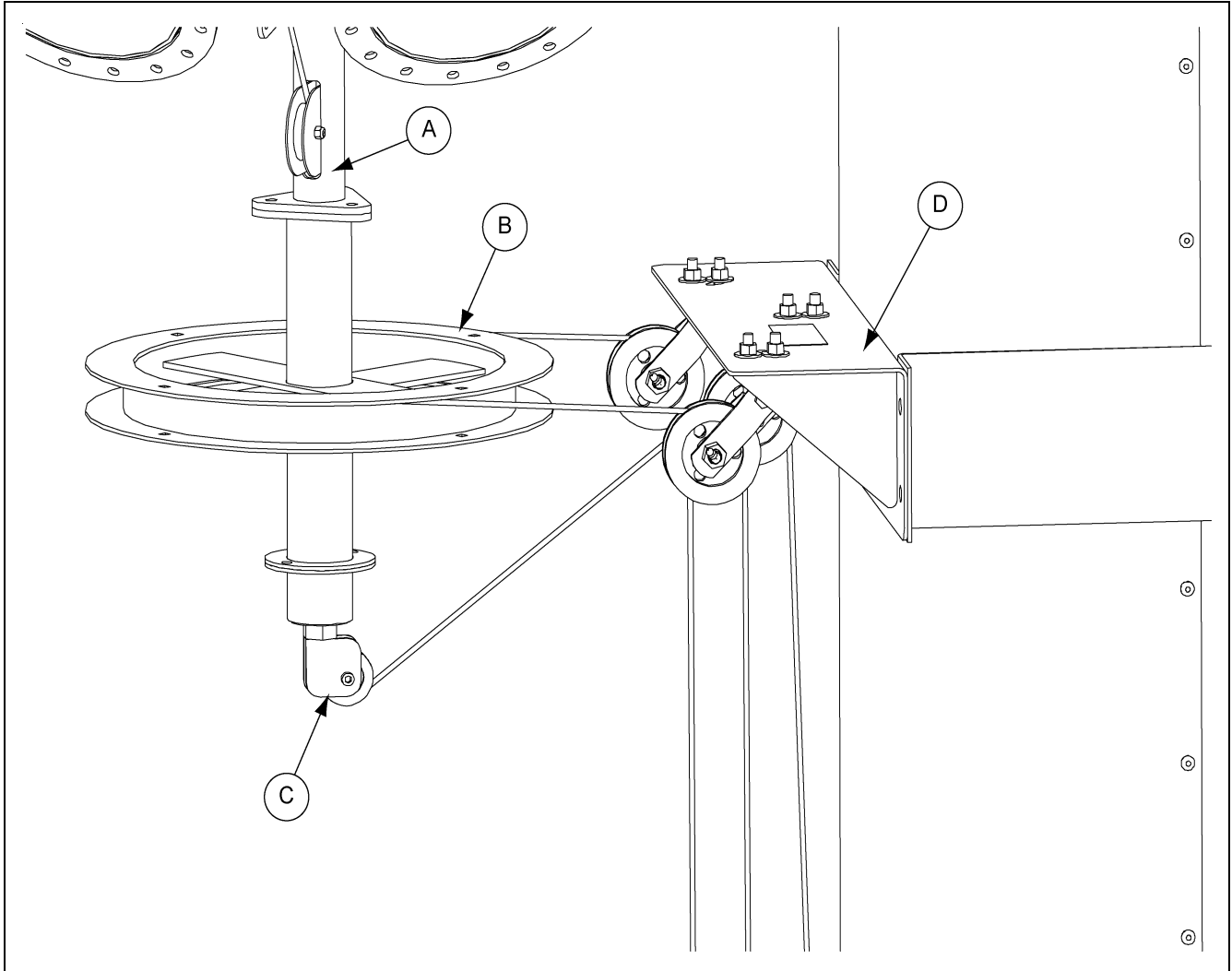

Figure 5C

Ref #	Part #	Description
A		Distributor Pipe Control
B	GSB-0061 DFB0389	Top Cable Wheel Weldment (For 6" and 8" Distributors) (For 10", 12" and 14" Distributors)
C	GSB-0045	Connector Pulley Assembly
D	DFB0388	Upper Cable Guide Assembly

5. Installation

Upper Cable Guide Assembly

Once the location of the upper cable guide assembly is determined, it must be fastened to the trunking. The assembly of the clamp band and upper cable guide assembly (C) is shown in [Figure 5D](#). The 1/2" x 2" bolts and nuts that fasten the clamp bands to the upper cable guide assembly are provide in the hardware package (FC-DCG-HDW).

NOTE: Use caution when tightening hardware, do not overtighten and collapse trunking.

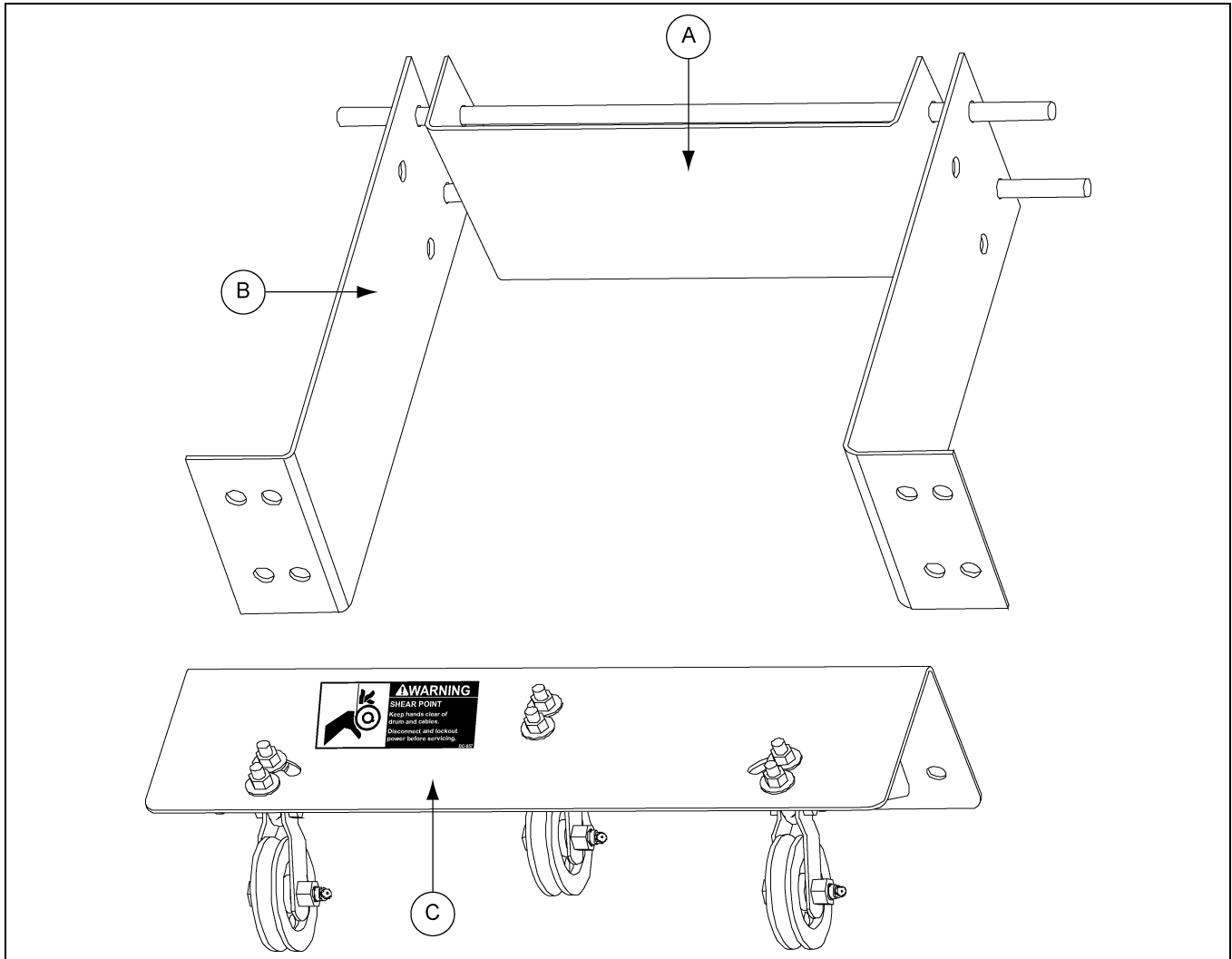

Figure 5D Trunking Removed for Clarity

Ref #	Part #	Description
A	DSP16005	Clamp Rod Weldment
B	DSP16002	16"-36" Clamp Band (2)
C	DFB0388	Cable Guide Assembly

16", 24", 30" and 36" Pulleys

Part #	Description	Qty
DSP16002	Clamp Band, 4 x 5 Platform	2
DSP16005	Clamp Rod Weldment, 4 x 5 Platform	1

Control Handle Installation

Once the upper assembly has been installed, the control handle needs to be assembled to the lower cable wheel assembly. There are two (2) brackets (B) that mount to the bottom of the lower cable wheel assembly (A). These brackets are fastened with 5/16" x 1" bolts and nuts. The control handle (C) is mounted between the brackets using the second hole in the control handle and the end hole on the brackets. This is fastened using 5/16" x 2" bolt and lock nut. The hardware required is located in (FC-DCG-HDW). This assembly is shown in [Figure 5E](#).

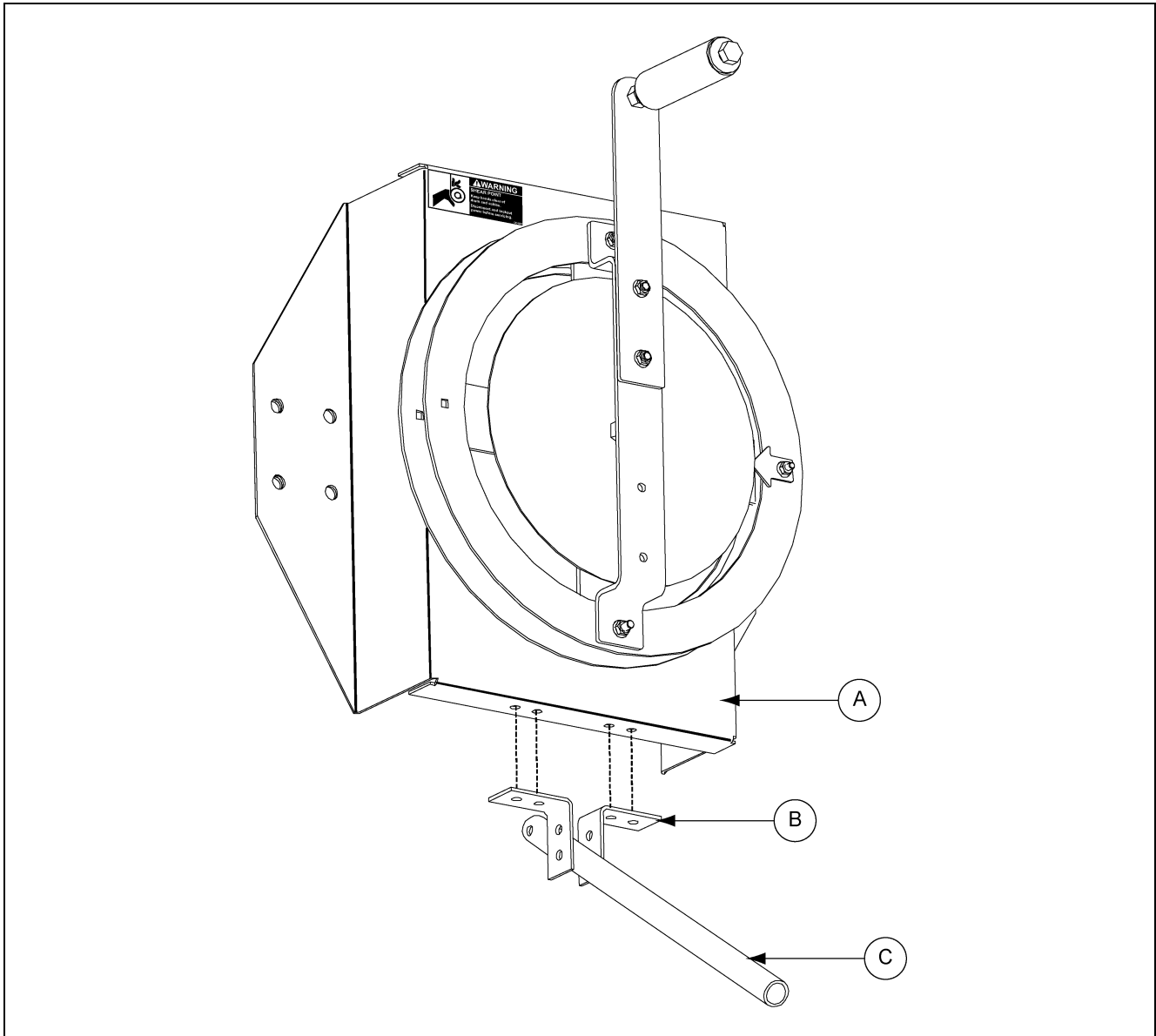

Figure 5E

Ref #	Part #	Description
A	GSB-0049 DFB0406	Bottom Cable Wheel Assembly (For 6" and 8" Distributors) (For 10", 12" and 14" Distributors)
B	GSB-0031	Control Handle Bracket
C	GSB-0030	Control Handle

5. Installation

Lower Cable Wheel Assembly

After assembling the control handle, install the lower cable wheel. The location of the lower cable wheel assembly is decided by where the operator will be positioned. Once the desired height has been determined for the lower cable wheel, fasten it to the trunking. The assembly of the lower cable wheel and clamp bands are shown in [Figure 5F](#). The 1/2" x 2" bolts and nuts to fasten clamp bands to the lower cable wheel are provided in the hardware package (FC-DCG-HDW).

NOTE: Use caution when tightening hardware, do not overtighten and collapse trunking.

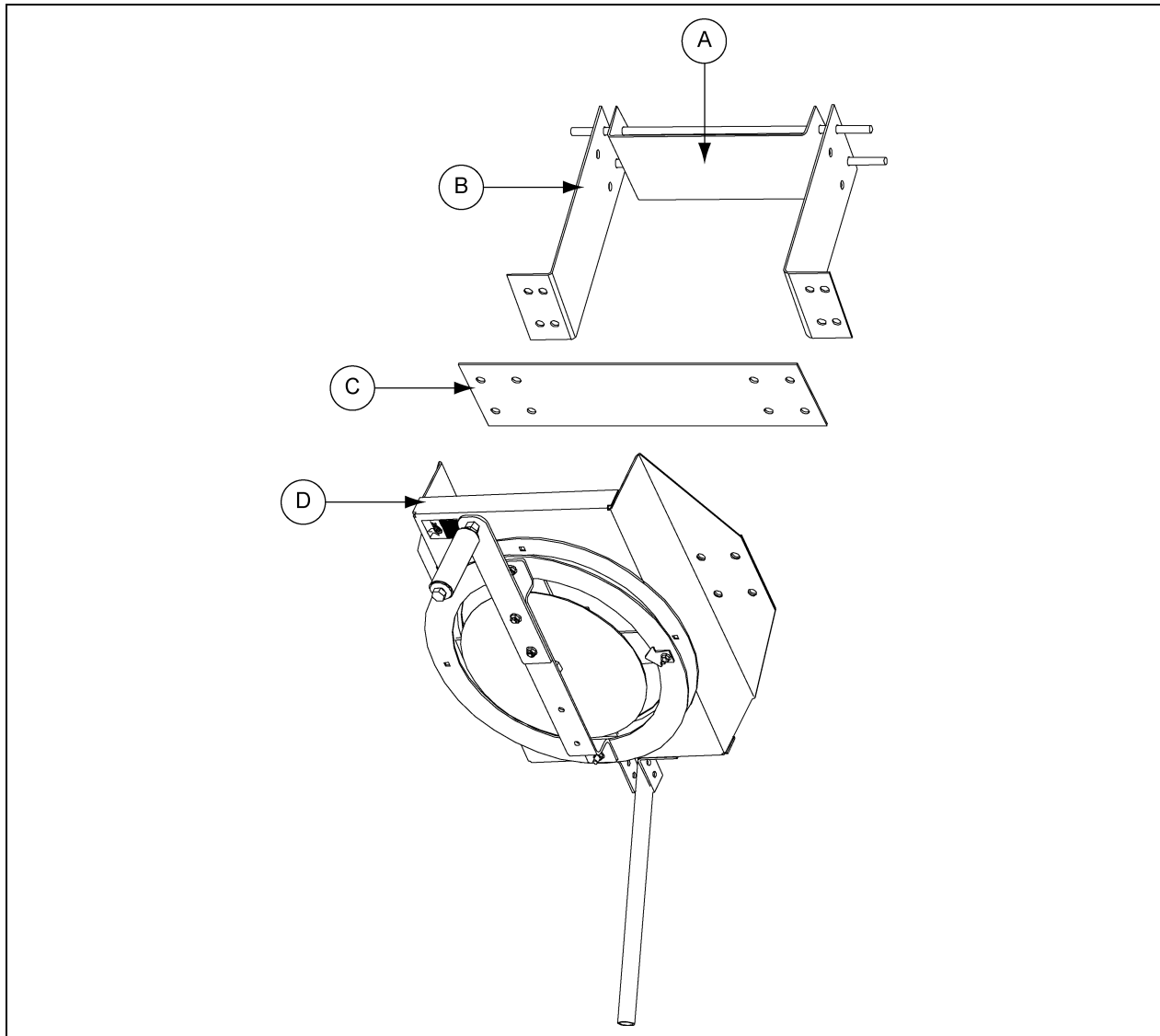

Figure 5F Trunking Removed for Clarity

Ref #	Part #	Description
A	DSP16005	Clamp Rod Weldment
B	DSP16002	16"-36" Clamp Band (2)
C	GSB-0006	Bottom Guide Spacer
D	GSB-0049 DFB0406	Bottom Cable Wheel Assembly (For 6" and 8" Distributors) (For 10", 12" and 14" Distributors)

Cable Guides

To help keep the cable in-line from the upper assembly to lower assembly, install intermediate cable guides. The quantity of intermediate cable guides to be installed is determined by the height of the leg. The company recommends that they be installed every 20'. These intermediate cable guides (B) are fastened at the trunking joints using the same hardware as the joint. The assembly shows how the intermediate cable guides are located on the trunk joints (A). (See [Figure 5G.](#)) For cable installation, See [Page 18.](#)

NOTE: Cable is not supplied with cable control. The company recommends 3/16" aircraft cable.

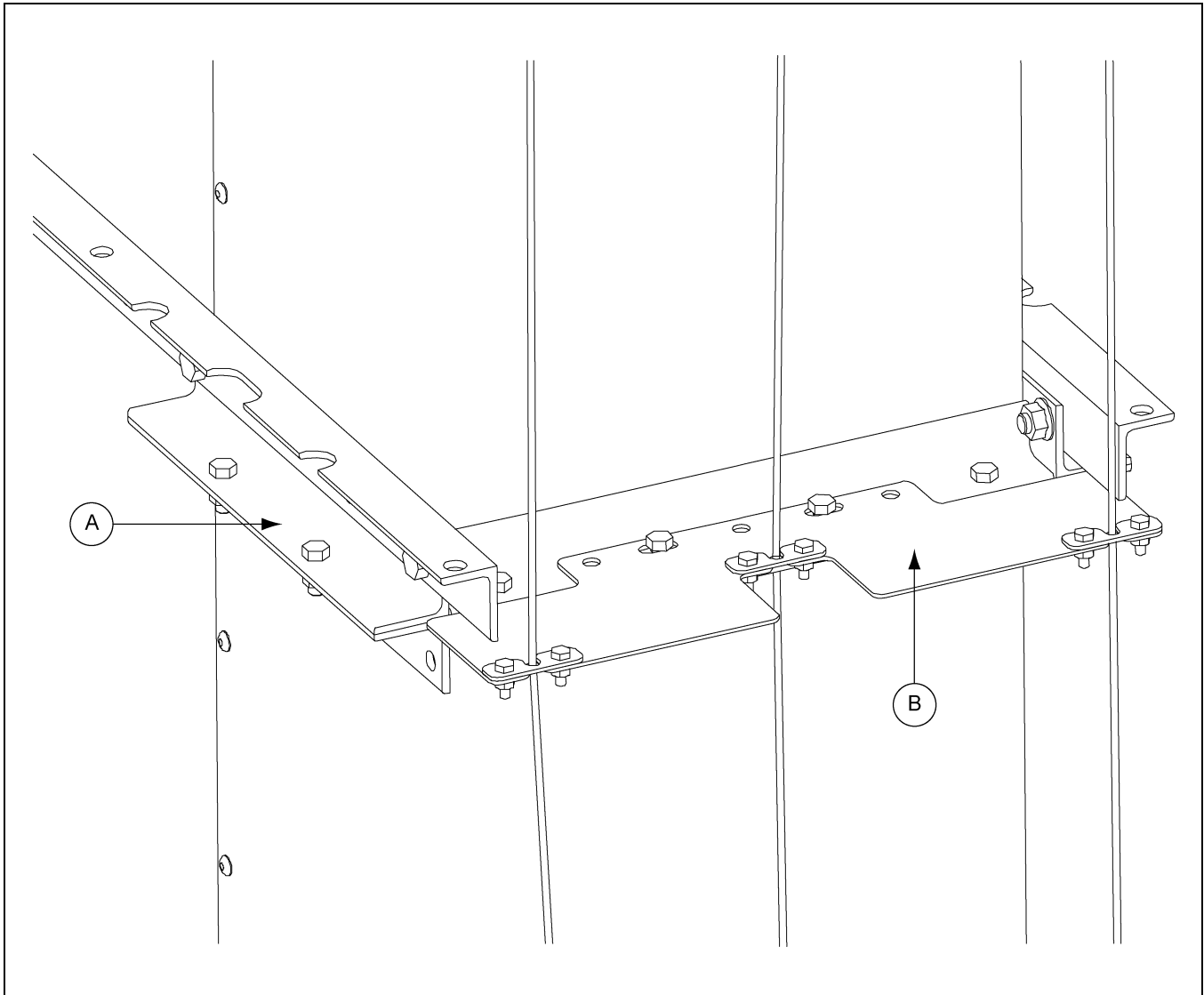

Figure 5G

Ref #	Part #	Description
A		Trunking Joint
B	GSB-0022	Cable Guide

5. Installation

Cable Installation

There is more than one way to install the cable for the cable control. We recommend that you rely on the qualified contractor's experience and techniques for cable installation. Below is an example of one method of installation.

You will need two (2) cables:

Cable 1, Spout Position Cable:

This cable is used to turn the spout. It should be long enough to reach from the upper control wheel to the lower control wheel assembly. This can be determined by the vertical distance between the two (2) wheels and the horizontal distance from the side of the trunking to the **center** of the upper control wheel. (See [Figure 5H](#) for formula.) Multiply this distance x 2 to account for the distance up and back down. Add 26' to this distance to account for 2-1/2 wraps around the upper and lower control wheels. (Approximately 3'-9" per wrap plus an extra 2 wraps allowance for possible error. 7 Wraps total = 26'.)

Spout position cable length formula: $(A+B \times 2) + 26' = \text{Cable}^1 \text{ length}$

NOTE: Cable is not supplied with cable control. The company recommends 3/16" aircraft cable.

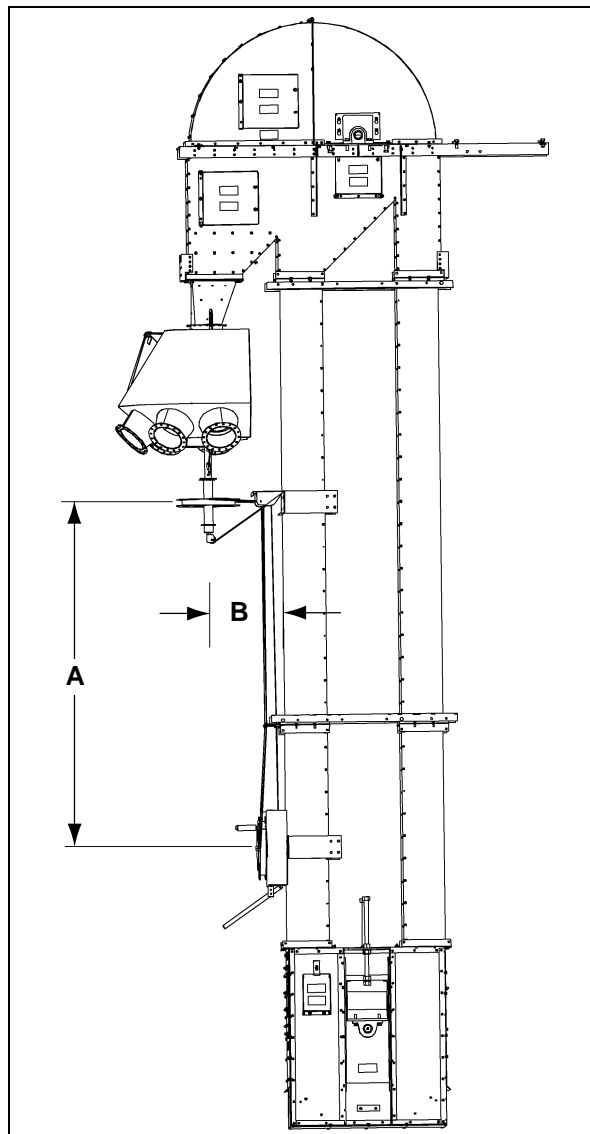
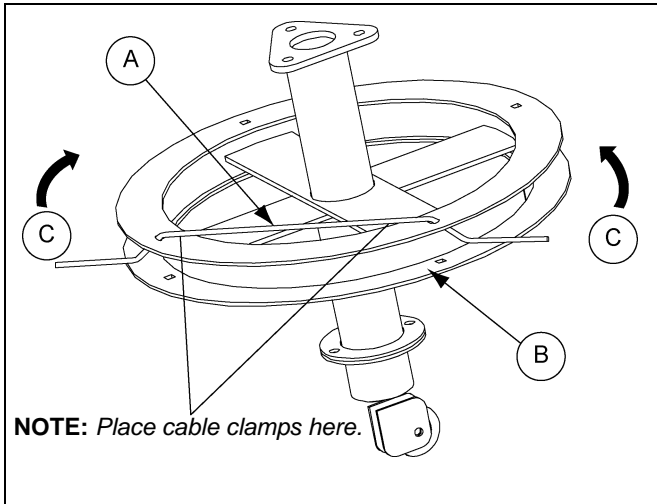

Figure 5H

When installing, mark the center of the cable. Start at the upper control wheel and feed the cable into the holes in the side of the control wheel (as shown in [Figure 5I](#)) until the center of the cable is between the two (2) holes in the side. Wrap each end of the cable one full wrap around wheel.



Ref #	Description
A	Center of Cable
B	Upper Control Wheel
C	1 Full Wrap

Figure 5I

Run both ends of the cable through the cable guides ([See Figure 5J](#)), continue down through the intermediate cable guides along trunking ([See Figure 5K on Page 20](#)), down to the lower cable wheel. Wrap each end of the cable 1 full wrap and then cable clamp both ends. ([See Figure 5L on Page 21.](#))

Cable 2, Spout Release Cable:

This cable is used to release the index trigger so that the spout can be turned. This cable should be able to reach from the control handle at the bottom side of the lower control wheel ([See Figure 5K on Page 20](#)), up over the center pulley of the cable guide assembly, under the connector pulley assembly and tie off at the index trigger. ([See Figure 5J.](#)) Allow some extra cable to be able to tie off at both ends.

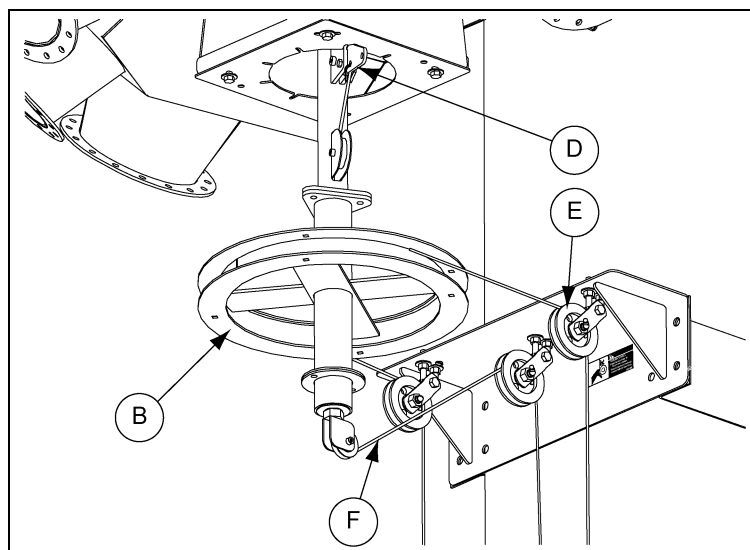

Figure 5J

Ref #	Description
B	Upper Control Wheel
D	Tied Off at Index Trigger

Ref #	Description
E	Cable Guides
F	Spout Release Cable

5. Installation

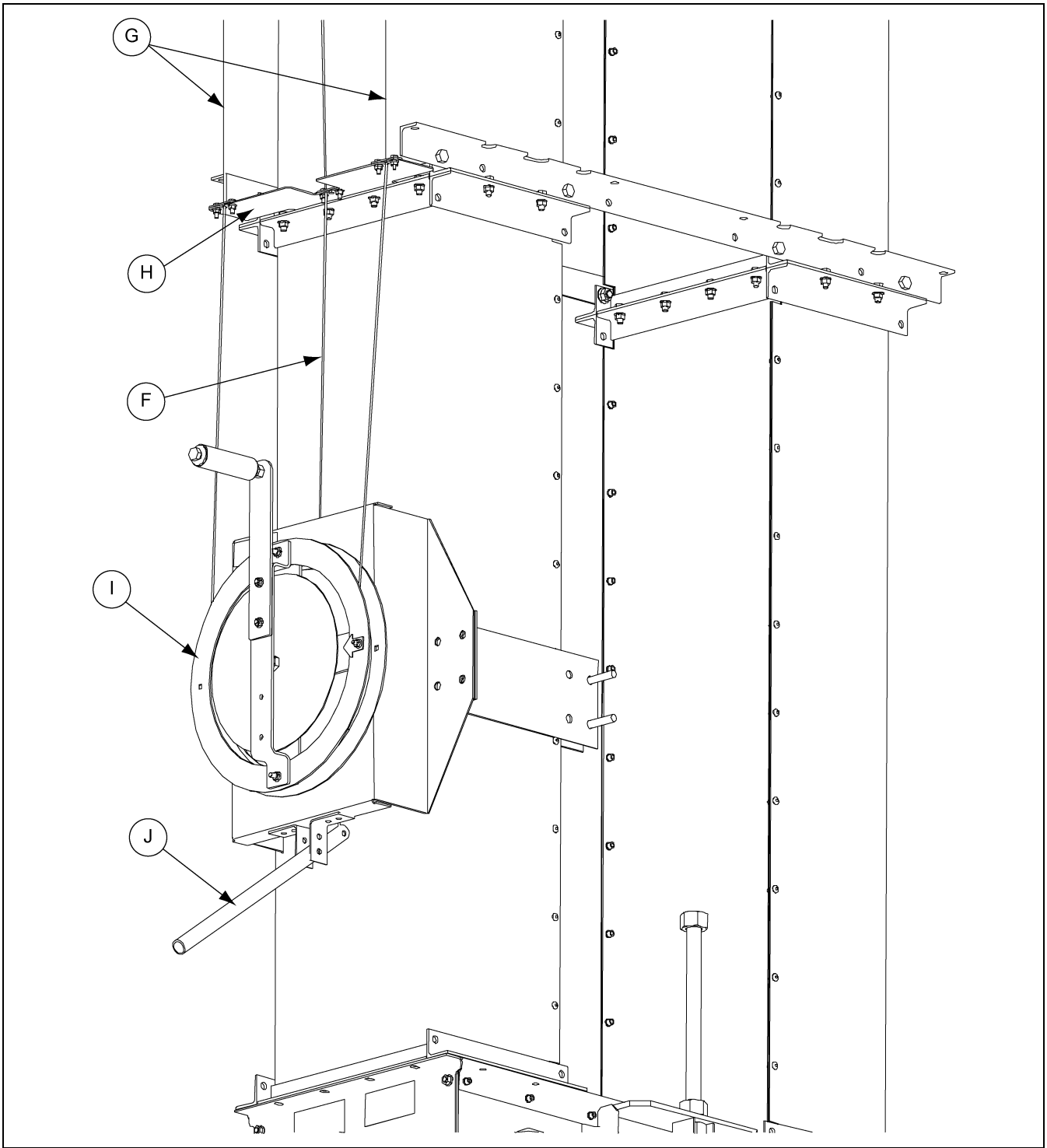

Figure 5K

Ref #	Description
F	Spout Release Cable
G	Spout Position Cables
H	Intermediate Cable Guide
I	Lower Control Wheel
J	Control Handle

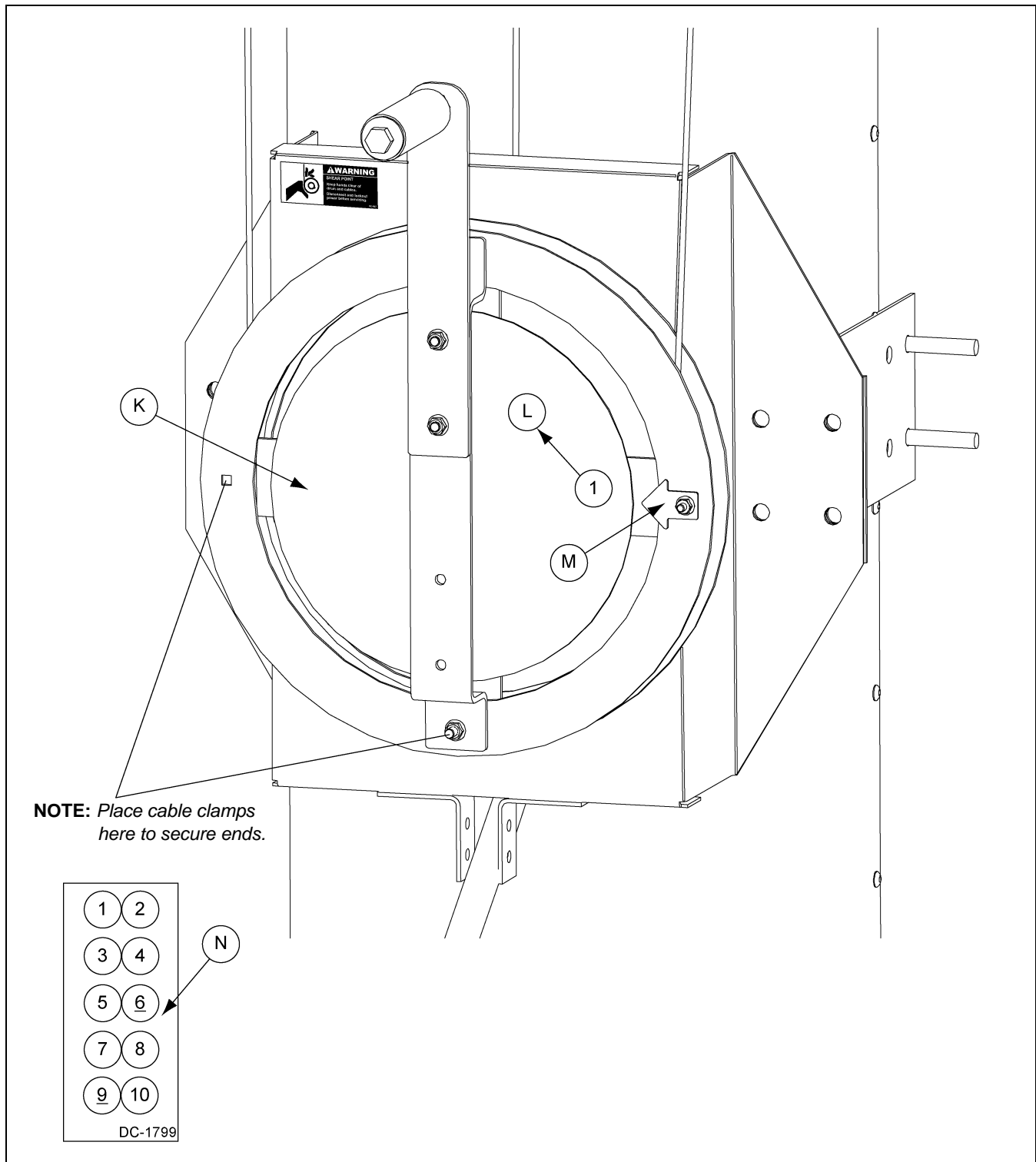

Figure 5L

Ref #	Description
K	Spout Decal Plate
L	Index Number Decal
M	Spout Position Arrow
N	#DC-1799 Decal Sheet

5. Installation

Calibrating the Distributor Spout and the Lower Cable Control Wheel

1. Place the discharge spout index trigger to the far right as shown in *Figure 5M*.
2. Using the index number decal (decal part #DC-1799), peel off one of the numbers (numbered 1 through 10) and place on the spout decal plate in front of the spout position arrow. (*See Figure 5L on Page 21.*)
3. Move to the next spout by pulling up on the control handle to disengage the index trigger while rotating the lower cable control wheel counterclockwise.
4. Repeat *Step 2* and *Step 3* until all spouts have been labeled on the spout decal plate.

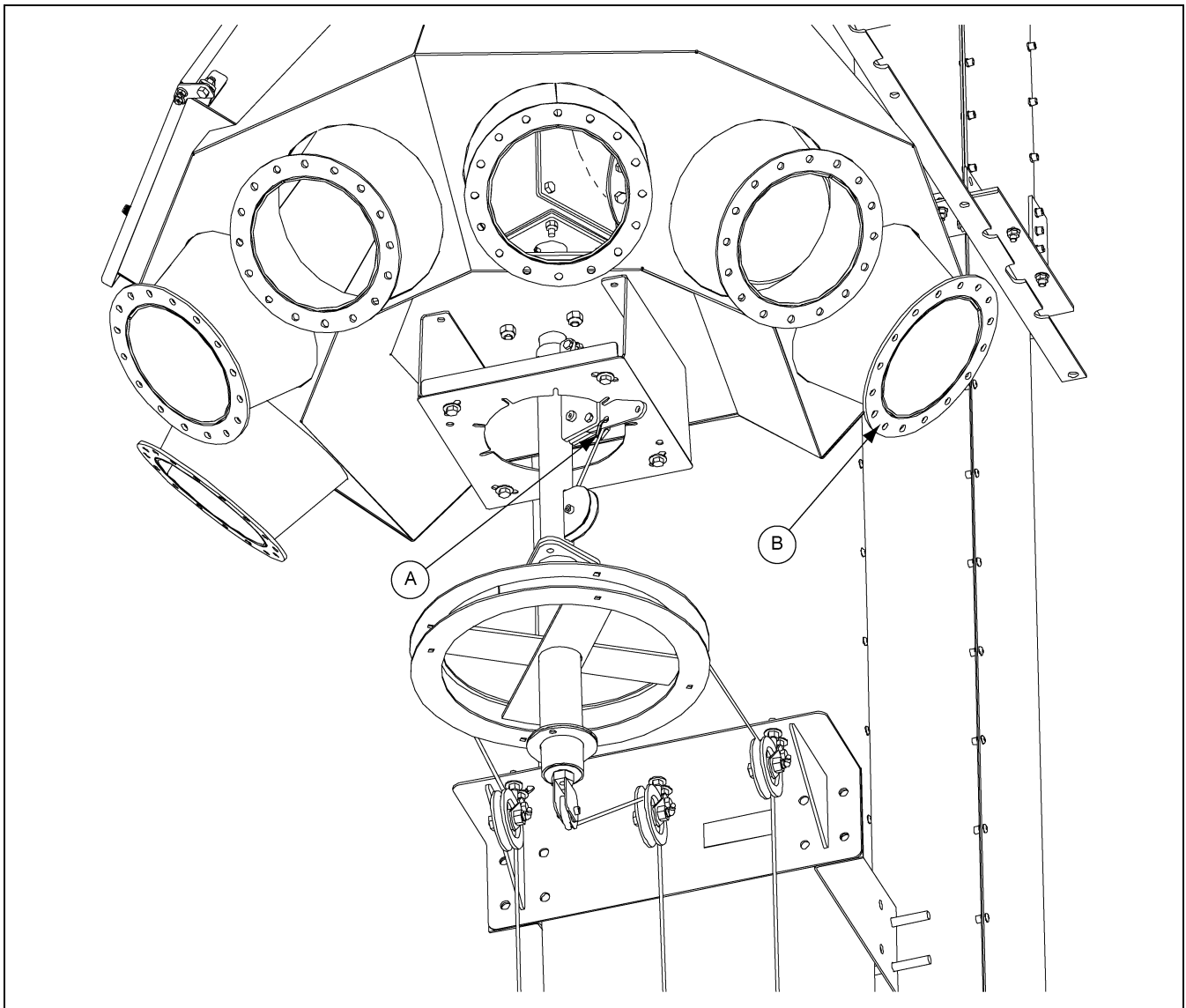

Figure 5M

Ref #	Description
A	Note Position Of The Index Trigger
B	Far Right Spout

Limited Warranty — N.A. Grain Products

The GSI Group, LLC. ("GSI") warrants products which it manufactures, to be free of defects in materials and workmanship under normal usage and conditions for a period of 12 months from the date of shipment (or, if shipped by vessel, 14 months from the date of arrival at the port of discharge). If, in GSI's sole judgment, a product is found to have a defect in materials and/or workmanship, GSI will, at its own option and expense, repair or replace the product or refund the purchase price. This Limited Warranty is subject to extension and other terms as set forth below.

Warranty Enhancements: The warranty period for the following products is enhanced as shown below and is in lieu of (and not in addition to) the above stated warranty period. (Warranty Period is from date of shipment.)

	Product	Warranty Period
Storage	Grain Bin Structural Design • Sidewall, roof, doors, platforms and walkarounds • Flooring (when installed using GSI specified floor support system for that floor) • Hopper tanks (BFT, GHT, NCHT, and FCHT)	5 Years
Conditioning	Dryer Structural Design – (Tower, Portable and TopDry) • Includes (frame, portable dryer screens, ladders, access doors and platforms)	5 Years
	All other Dryer parts including: • Electrical (controls, sensors, switches and internal wiring)	2 Years
	All Non-PTO Driven Centrifugal and Axial Fans	3 Years
	Bullseye Controllers	2 Years
Material Handling	Bucket Elevators Structural Design	5 Years
	Towers Structural Design	5 Years
	Catwalks Structural Design	5 Years
	Accessories (stairs, ladders and platforms) Structural Design	5 Years

Conditions and Limitations:

THERE ARE NO WARRANTIES THAT EXTEND BEYOND THE LIMITED WARRANTY DESCRIPTION SET FORTH HEREIN; SPECIFICALLY, GSI DISCLAIMS ANY AND ALL OTHER WARRANTIES OF ANY KIND, EXPRESS OR IMPLIED, INCLUDING, WITHOUT LIMITATION, WARRANTIES OF MERCHANTABILITY OR FITNESS FOR A PARTICULAR PURPOSE OR USE IN CONNECTION WITH: (I) ANY PRODUCT MANUFACTURED OR SOLD BY GSI, OR (II) ANY ADVICE, INSTRUCTION, RECOMMENDATION OR SUGGESTION PROVIDED BY AN AGENT, REPRESENTATIVE OR EMPLOYEE OF GSI REGARDING OR RELATED TO THE CONFIGURATION, INSTALLATION, LAYOUT, SUITABILITY FOR A PARTICULAR PURPOSE, OR DESIGN OF SUCH PRODUCTS.

The sole and exclusive remedy for any claimant is set forth in this Limited Warranty and shall not exceed the amount paid for the product purchased. This Warranty only covers the value of the warranted parts and equipment, and does not cover labor charges for removing or installing defective parts, shipping charges with respect to such parts, any applicable sales or other taxes, or any other charges or expenses not specified in this Warranty. GSI shall not be liable for any other direct, indirect, incidental or consequential damages, including, without limitation, loss of anticipated profits or benefits. Expenses incurred by or on behalf of a claimant without prior written authorization from the GSI warranty department shall not be reimbursed. This warranty is not transferable and applies only to the original end-user. GSI shall have no obligation or responsibility for any representations or warranties made by or on behalf of any dealer, agent or distributor. Prior to installation, the end-user bears all responsibility to comply with federal, state and local codes which apply to the location and installation of the products.

This Limited Warranty extends solely to products sold by GSI and does not cover any parts, components or materials used in conjunction with the product, that are not sold by GSI. GSI assumes no responsibility for claims resulting from construction defects, unauthorized modifications, corrosion or other cosmetic issues caused by storage, application or environmental conditions. Modifications to products not specifically delineated in the manual accompanying the product at initial sale will void all warranties. This Limited Warranty shall not extend to products or parts which have been damaged by negligent use, misuse, alteration, accident or which have been improperly/inadequately maintained.

Notice Procedure:

In order to make a valid warranty claim a written notice of the claim must be submitted, using the RMA form, within 60 days of discovery of a warrantable nonconformance. The RMA form is found on the OneGSI portal.

Service Parts:

GSI warrants, subject to all other conditions described in this Warranty, Service Parts which it manufactures for a period of 12 months from the date of purchase unless specified in Enhancements above.

This equipment shall be installed in accordance with the current installation codes and applicable regulations, which should be carefully followed in all cases. Authorities having jurisdiction should be consulted before installations are made.



GSI Group
1004 E. Illinois St.
Assumption, IL 62510-0020
Phone: 1-217-226-4421
Fax: 1-217-226-4420
www.gsiag.com



GSI is a worldwide brand of AGCO Corporation.