

16"-24" Bucket Elevator Platform and Ladder "X" Series

Installation Manual

PNEG-1807

Date: 05-16-14

G S I G R O U P



PNEG-1807

Use of the equipment information page will help you identify the equipment in the case that you need to call your dealer or installer. This information should be filled out and kept on record.

Equipment Information

Model #: _____

Serial #: _____

Date Purchased: _____

Dealer/Distributor Name and Phone #: _____

Material Handling

1004 E. Illinois St.
Assumption, IL. 62510
Phone: 1-217-226-4421

Contents

Chapter 1 Introduction	4
Chapter 2 Safety	5
Safety Guidelines	5
Safety Instructions	6
Chapter 3 Decal Location	8
Chapter 4 Overview	9
Chapter 5 Ladder Assembly	10
Typical Ladder/Cage Setup	18
Chapter 6 Tie Angles, Ladder Brackets and Safety Cages	19
Attach Tie Angle to Boot Trunking	19
Attach Boot Ladder Support Brackets and Boot Ladder Section	21
Install Boot Ladder Section	25
Tie Angles to Trunking	27
Ladder Support Brackets	30
Attach Ladders to Ladder Brackets	33
Safety Cage Installation	34
Install Safety Cage	35
Chapter 7 Rest Platform	38
Rest Platform Tie Angles to Bucket Elevators	38
Attach Rest Platform Channel to the Rest Platform Tie Angle	42
Rest Platform Cross Channel to Rest Platform Mounting Channels	43
Ladder Support	51
Chapter 8 16"-24" Head Platform Assembly	52
Attach Main Support Channels to Lower Head	52
Install Deck A and Toe Board	53
Install Deck A to Main Support Channels	54
Install Deck C and Toe Board	56
Install Deck C to Main Support Channels	57
Install Deck E	58
Install Adapter Bracket for 16" Platforms	61
Install Hatch Filler Plate	62
Install Rail Supports to Deck E	63
Install "W" Posts ("Corner Posts" x 4)	64
Install Platform Posts	65
Install Intermediate Handrails	67
Install Upper Handrails	69
Install Tie Braces (Safety Cage Bars)	70
Chapter 9 Install Hatch	71
Chapter 10 4 x 5 Distributor Platform (Optional)	75
16"-24" Clamp Band Installation	75
Assemble Supports (16"-24")	79
Assemble Decking and "W" Corner Post	81
Install Handrail Posts - Non-Entrance Side	84
Install Intermediate Handrails	85
Install Safety Bar Cross Supports	86
Install Top Handrails	87
Safety Gate Package (Optional)	88
Chapter 11 Warranty	89

Chapter 1: Introduction

READ THIS MANUAL carefully to learn how to properly use and install equipment. Failure to do so could result in personal injury or equipment damage.

INSPECT the shipment immediately upon arrival. The customer is responsible for ensuring that all quantities are correct. The customer should report and note any damage or shortage on the bill of lading to justify their claim to the transport company.

THIS MANUAL SHOULD BE CONSIDERED a permanent part of your equipment and should be easily accessible when needed.

This warranty provides you the assurance that the company will back its products when defects appear within the warranty period. In some circumstances, the company also provides field improvements, often without charge to the customer, even if the product is out of warranty. Should the equipment be abused, or modified to change its performance beyond the factory specifications, the warranty will become void and field improvements may be denied.

Chapter 2: Safety

Safety Guidelines

This manual contains information that is important for you, the owner/operator, to know and understand. This information relates to protecting **personal safety** and **preventing equipment problems**. It is the responsibility of the owner/operator to inform anyone operating or working in the area of this equipment of these safety guidelines. To help you recognize this information, we use the symbols that are defined below. Please read the manual and pay attention to these sections. Failure to read this manual and its safety instructions is a misuse of the equipment and may lead to serious injury or death.



This is the safety alert symbol. It is used to alert you to potential personal injury hazards. Obey all safety messages that follow this symbol to avoid possible injury or death.



DANGER indicates a hazardous situation which, if not avoided, will result in death or serious injury.



WARNING indicates a hazardous situation which, if not avoided, could result in death or serious injury.



CAUTION, used with the safety alert symbol, indicates a hazardous situation which, if not avoided, could result in minor or moderate injury.



NOTICE is used to address practices not related to personal injury.

2. Safety

Safety Instructions

Our foremost concern is your safety and the safety of others associated with this equipment. We want to keep you as a customer. This manual is to help you understand safe operating procedures and some problems that may be encountered by the operator and other personnel.

As owner and/or operator, it is your responsibility to know what requirements, hazards, and precautions exist, and to inform all personnel associated with the equipment or in the area. Safety precautions may be required from the personnel. Avoid any alterations to the equipment. Such alterations may produce a very dangerous situation where **SERIOUS INJURY** or **DEATH** may occur.

This equipment shall be installed in accordance with the current installation codes and applicable regulations, which should be carefully followed in all cases. Authorities having jurisdiction should be consulted before installations are made.

Follow Safety Instructions

Carefully read all safety messages in this manual and safety signs on your machine. Keep signs in good condition. Replace missing or damaged safety signs. Be sure new equipment components and repair parts include the current safety signs. Replacement safety signs are available from the manufacturer.

Learn how to operate the machine and how to use controls properly. Do not let anyone operate without instruction.

Keep your machinery in proper working condition. Unauthorized modifications to the machine may impair the function and/or safety and affect machine life.

If you do not understand any part of this manual or need assistance, contact your dealer.

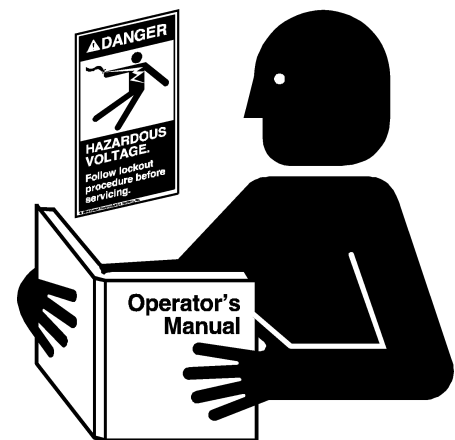

Read and Understand Manual

Practice Safe Maintenance

Understand service procedures before doing work. Keep area clean and dry.

Never lubricate, service, or adjust machine while it is in operation. Keep hands, feet, and clothing away from rotating parts.

Keep all parts in good condition and properly installed. Fix damage immediately. Replace worn or broken parts. Remove any built-up grease, oil, and debris.



Maintain Equipment and Work Area

Prepare for Emergencies

Be prepared if fire starts.

Keep a first aid kit and fire extinguisher handy.

Keep emergency numbers for doctors, ambulance service, hospital, and fire department near your telephone.

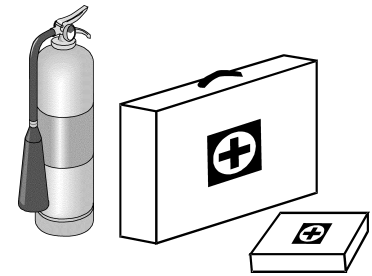

Keep Emergency Equipment Quickly Accessible

Wear Protective Clothing

Wear close-fitting clothing and safety equipment appropriate to the job.

Remove all jewelry.

Tie long hair up and back.

Wear safety glasses at all times to protect eyes from debris.

Wear gloves to protect your hands from sharp edges on plastic or steel parts.

Wear steel-toed boots to help protect your feet from falling debris. Tuck in any loose or dangling shoestrings.

A respirator may be needed to prevent breathing potentially toxic fumes and dust.

Wear a hard hat to help protect your head.

Wear appropriate fall protection equipment when working at elevations greater than six feet (6').

Eye Protection

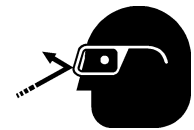

Gloves



Steel-Toed Boots



Respirator



Hard Hat



Fall Protection



Chapter 3: Decal Location

 DANGER	
	<p>DO NOT EXCEED PLATFORM LOAD LIMIT</p> <p>Load limit = 500 LBS. (2.25 kN)</p> <p>Excessive load will damage platform and cause platform to fall.</p> <p>Injury or death will result.</p> <p style="text-align: right;">DC-2146</p>

	WARNING
	<p>FALL HAZARD</p> <ul style="list-style-type: none">• Fall hazard present when hatch door open.• Fall may result in serious injury or death• Close hatch door while on platform. <p style="text-align: right;">DC-2147</p>

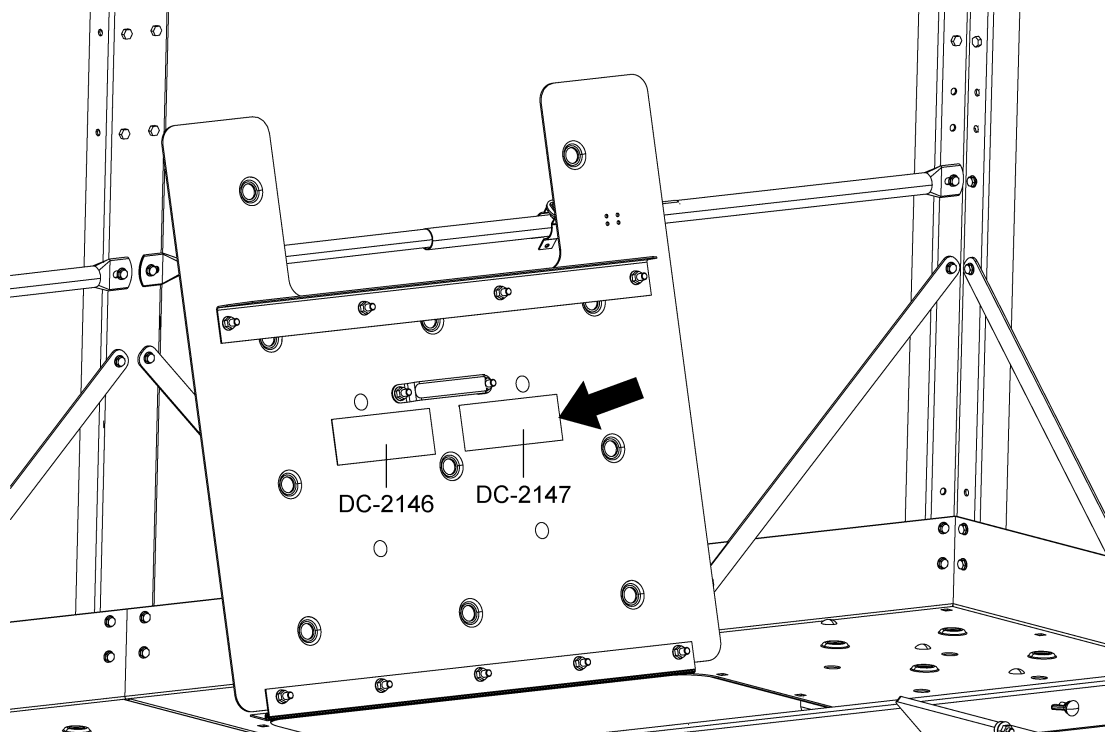

Chapter 4: Overview

This section is intended to provide a general, high-level overview of platform assembly for your GSI bucket elevator. Detailed instructions are given in the pages to come.

This section should be used for reference only and is intended to provide general guidance about the overall process only.

1. Support Channels:

Proper orientation of channels is based upon the size of the bucket elevator (16", 24", 30" or 36") AND the right/left hand position of the drive. This must be installed correctly at the start or nothing else will install correctly.

2. Ladders and Safety Cages:

Ladder sections mount directly to the trunking sections of the bucket elevator. Typical ladder layouts and charts identifying the support height for ladder packages can be found [on Pages 10 through 17](#).

3. Tie Angles to Trunking:

- Proper orientation of the tie angles is critical for correct installation.
- Note differences from up-leg and down-leg installations.

Be sure to follow the instructions for the size and drive position.

Throughout this manual, particular attention is given to the initial orientation of channels and aligning bolt holes. Failure to complete these initial steps correctly will significantly impede the assembly and installation of the bucket elevator platforms.

4. Decking and Toe Boards:

Decking is etched with alpha characters to assist with orienting decks and aligning holes for connections. Decking connections should be finger-tight only initially so that adjustments can be made once all decks and toe boards are in place. Only then should all hardware be fully torqued.

5. Handrail Platform Posts:

The number and location of platform posts varies based upon platform and bucket elevator size.

6. Handrails:

Intermediate handrails (those at near knee level) may need to be field cut to fit. The amount to trim varies based upon the size of the platform being installed. The smaller rail then fits inside of the larger rail so that it “telescopes” between the posts. Always follow best practices of “measure twice cut once” and verify the measurement is for the bucket elevator size. Upper handrails do not require any alterations in the field prior to assembly.

7. Platform Braces:

Throughout this manual, safety cage bars (LDR-517BE) are used as platform braces. These are required for support and stability. Please attach as described through the manual.

5. Ladder Assembly

Chapter 5: Ladder Assembly

The ladder sections are to be mounted directly to the trunking sections. Quantities and section lengths may vary depending on overall height of system. If you have a non-standard height system, refer to supported bucket height reference chart [below](#) for the correct ladder package for the system.

Supported Bucket Height Reference Chart

Part #	Supported Bucket Height (Ft.)	Part #	Supported Bucket Height (Ft.)
1636XRLAD20	0-29	1636XWLAD20	0-29
1636XRLAD30	30-39	1636XWLAD30	30-39
1636XRLAD40	40-49	1636XWLAD40	40-49
1636XRLAD50	50-59	1636XWLAD50	50-59
1636XRLAD60	60-69	1636XWLAD60	60-69
1636XRLAD70	70-79	1636XWLAD70	70-79
1636XRLAD80	80-89	1636XWLAD80	80-89
1636XRLAD90	90-99	1636XWLAD90	90-99
1636XRLAD100	100-109	1636XWLAD100	100-109
1636XRLAD110	110-119	1636XWLAD110	110-119
1636XRLAD120	120-129	1636XWLAD120	120-129
1636XRLAD130	130-139	1636XWLAD130	130-139
1636XRLAD140	140-149	1636XWLAD140	140-149
1636XRLAD150	150-159	1636XWLAD150	150-159
1636XRLAD160	160-169	1636XWLAD160	160-169
1636XRLAD170	170-179	1636XWLAD170	170-179
1636XRLAD180	180-189	1636XWLAD180	180-189
1636XRLAD190	190-199	1636XWLAD190	190-199
1636XRLAD200	200-209	1636XWLAD200	200-209

NOTE: *Ladders are of a modular design for ease of modification in the field. These illustrations are only to be used as a “general” guide to installation layout. The exact assembly may vary due to the unique nature of each bucket elevator.*

See Figures 5A-5G on Pages 11-17 to help determine if the ladders should be started on the up-leg or down-leg of the elevator and also aid in the ladder order and rest platform locations for bucket elevators with heights from 20' through 180'.



Due to O.H.S.A. standards, it is required that a rest platform be installed every 30'.

Key: HP = Head Platform
RP = Rest Platform

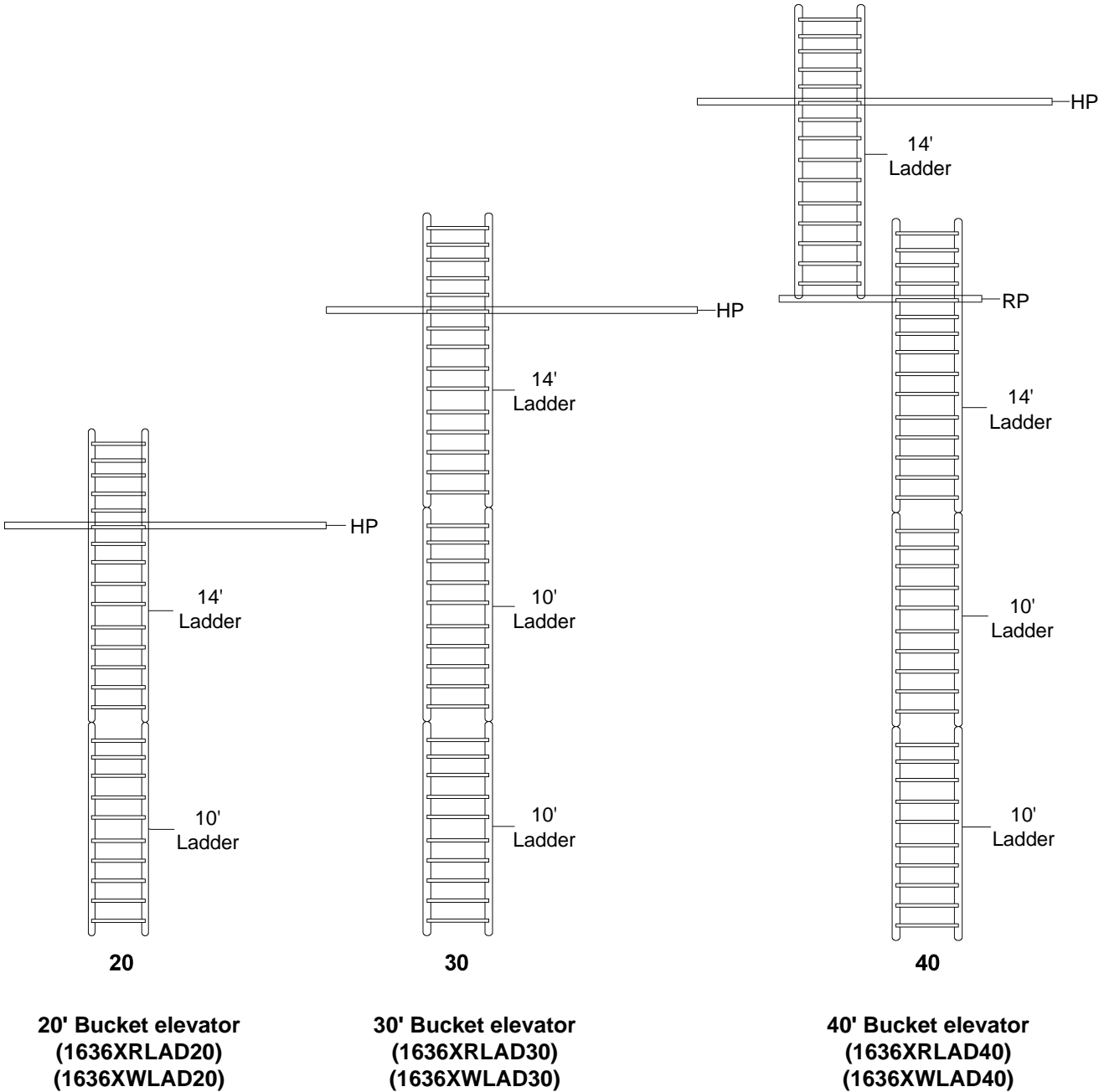

Figure 5A

5. Ladder Assembly

Key: HP = Head Platform
RP = Rest Platform

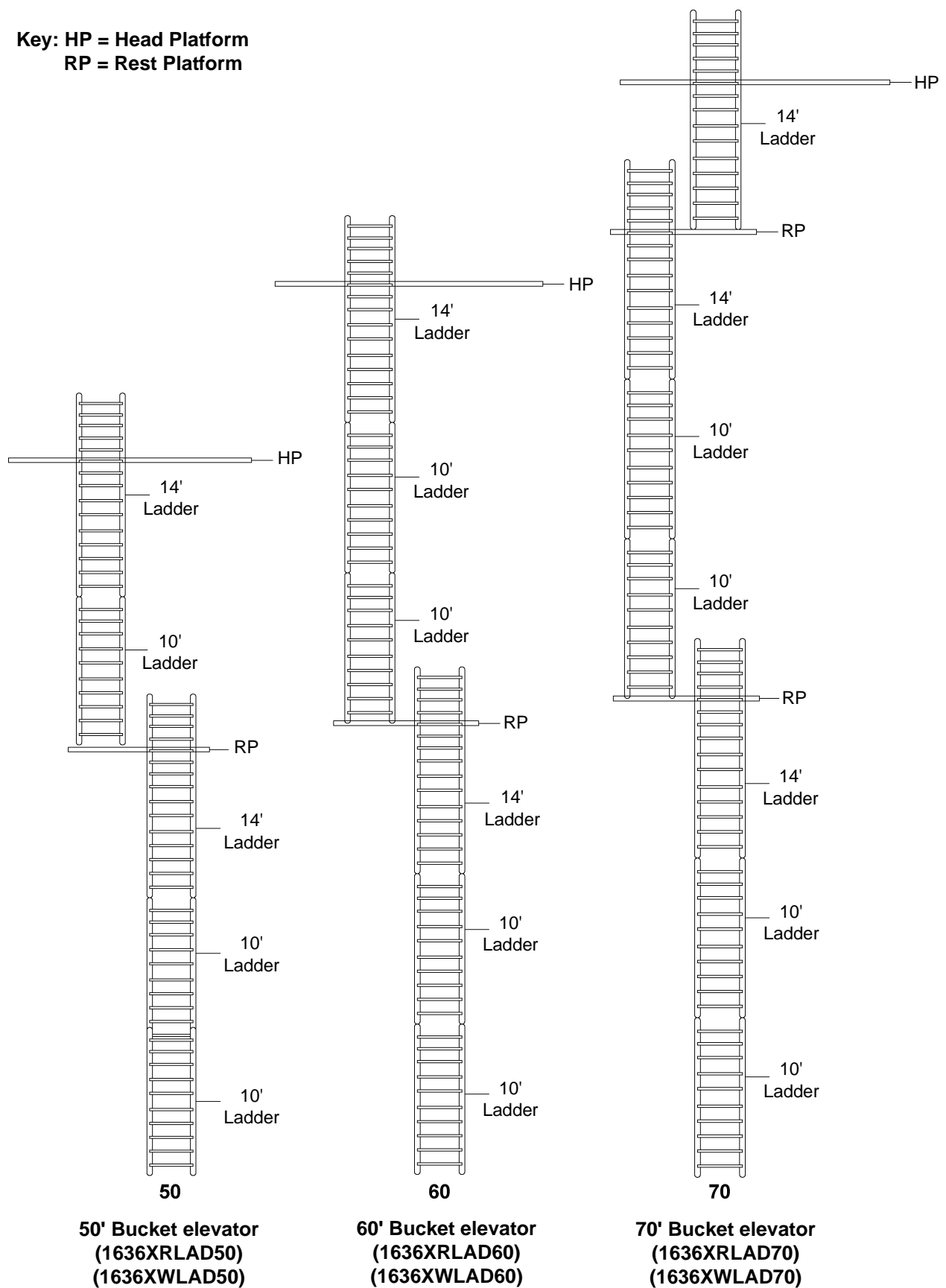
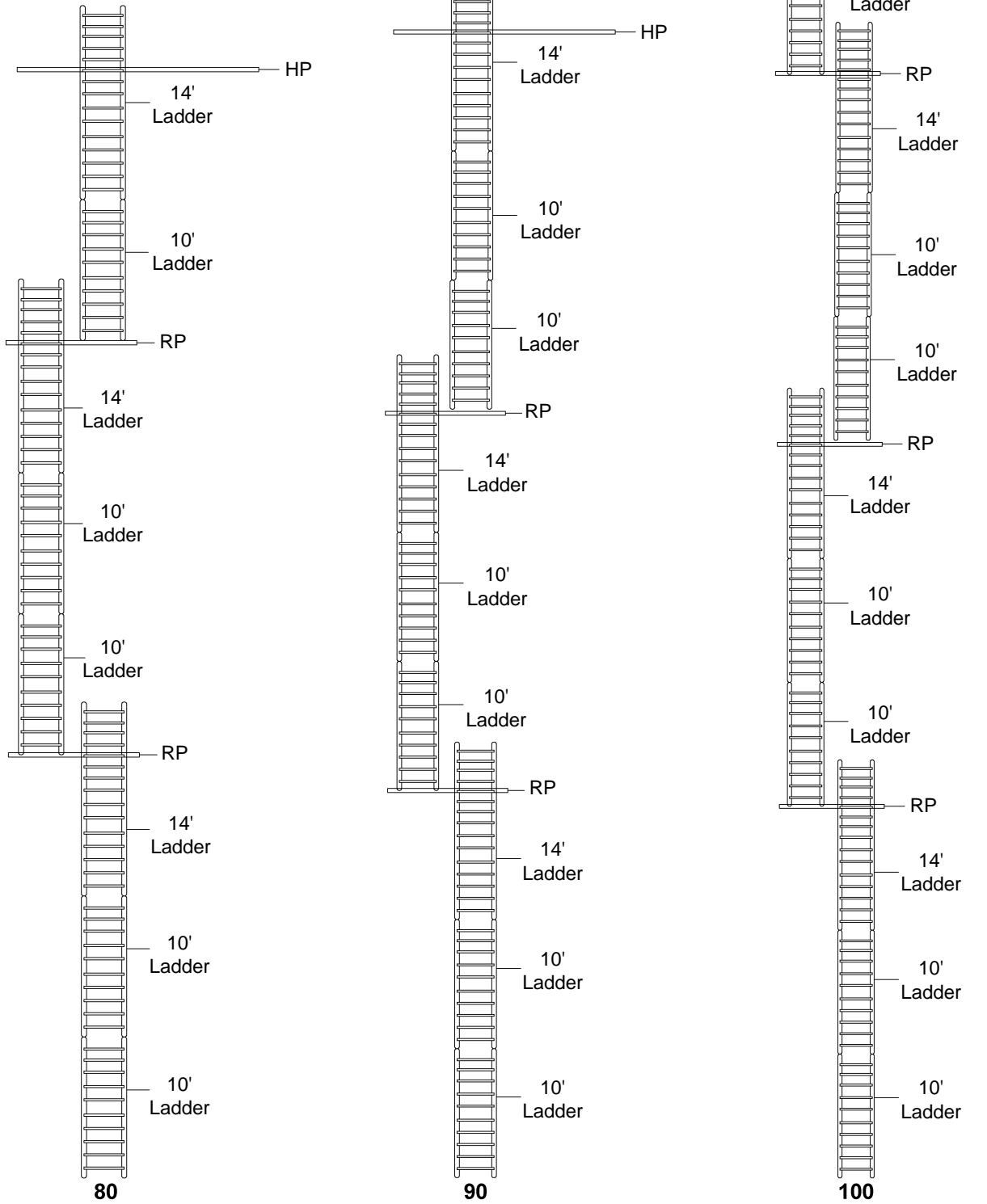

Figure 5B

Key: HP = Head Platform
 RP = Rest Platform



80' Bucket elevator
 (1636XRLAD80)
 (1636XWLAD80)

90' Bucket elevator
 (1636XRLAD90)
 (1636XWLAD90)

100' Bucket elevator
 (1636XRLAD100)
 (1636XWLAD100)

Figure 5C

5. Ladder Assembly

Key: HP = Head Platform
RP = Rest Platform

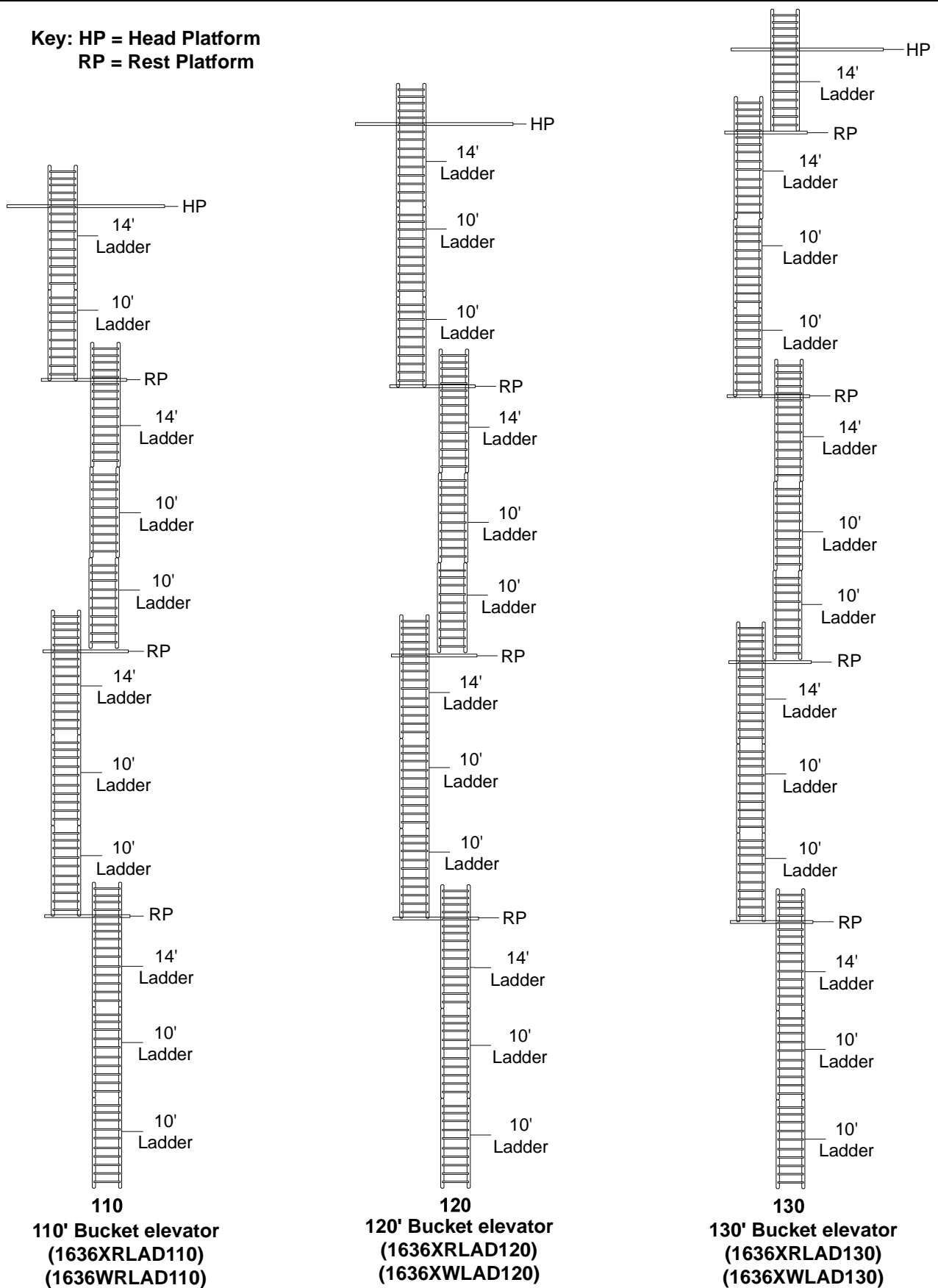
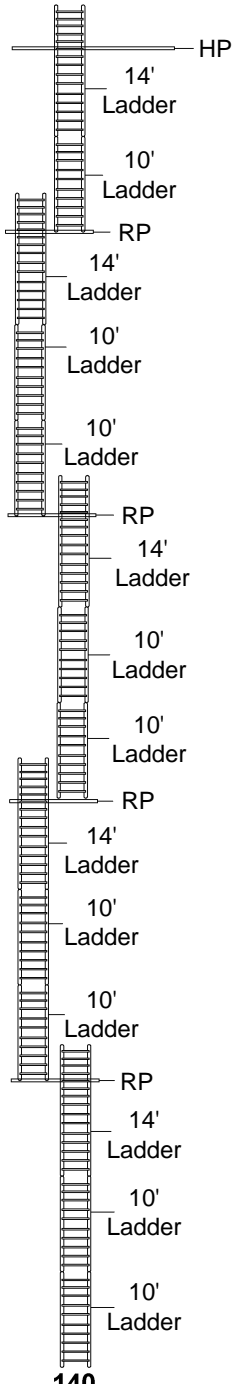
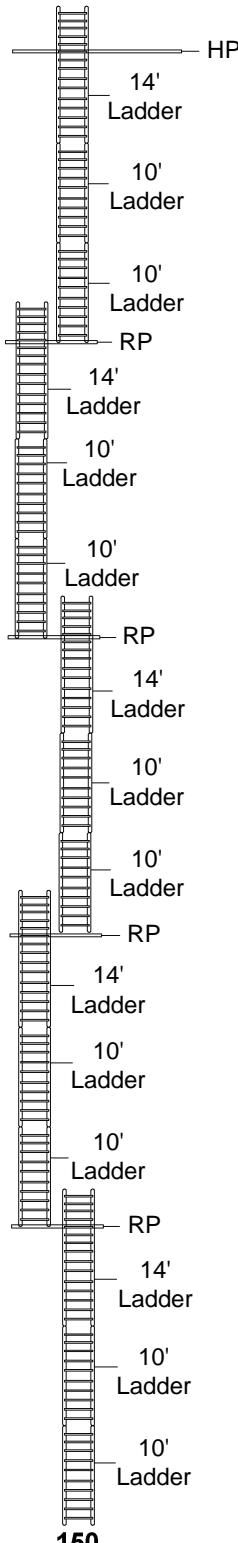

Figure 5D

Key: HP = Head Platform
 RP = Rest Platform



140
140' Bucket elevator
(1636XRLAD140)
(1636XWLAD140)



150
150' Bucket elevator
(1636XRLAD150)
(1636XWLAD150)

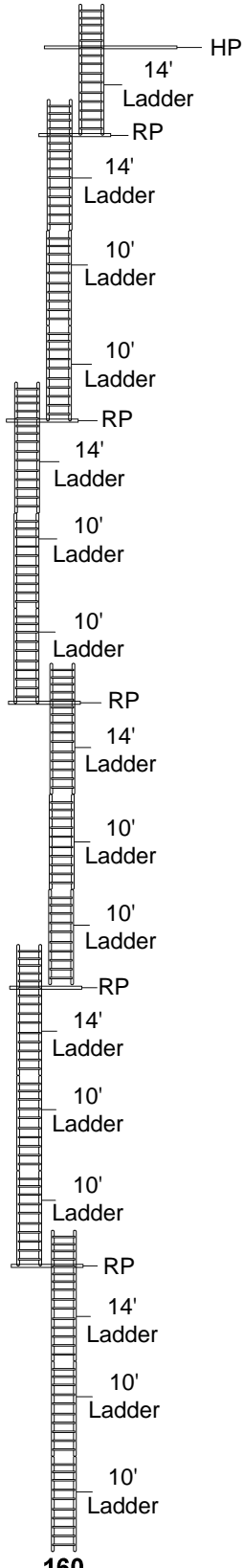

160
160' Bucket elevator
(1636XRLAD160)
(1636XWLAD160)

Figure 5E

5. Ladder Assembly

Key: HP = Head Platform
RP = Rest Platform

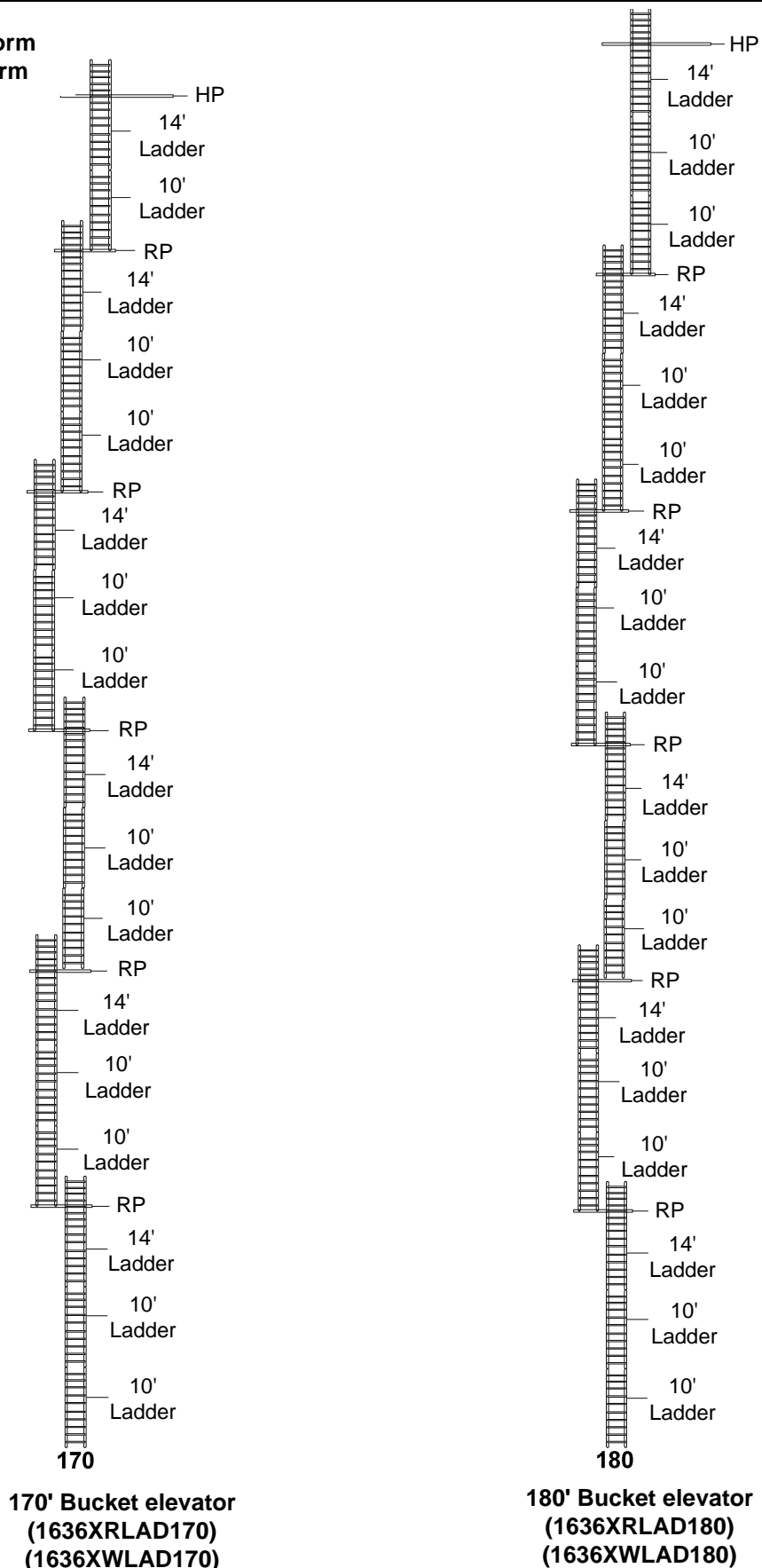

Figure 5F

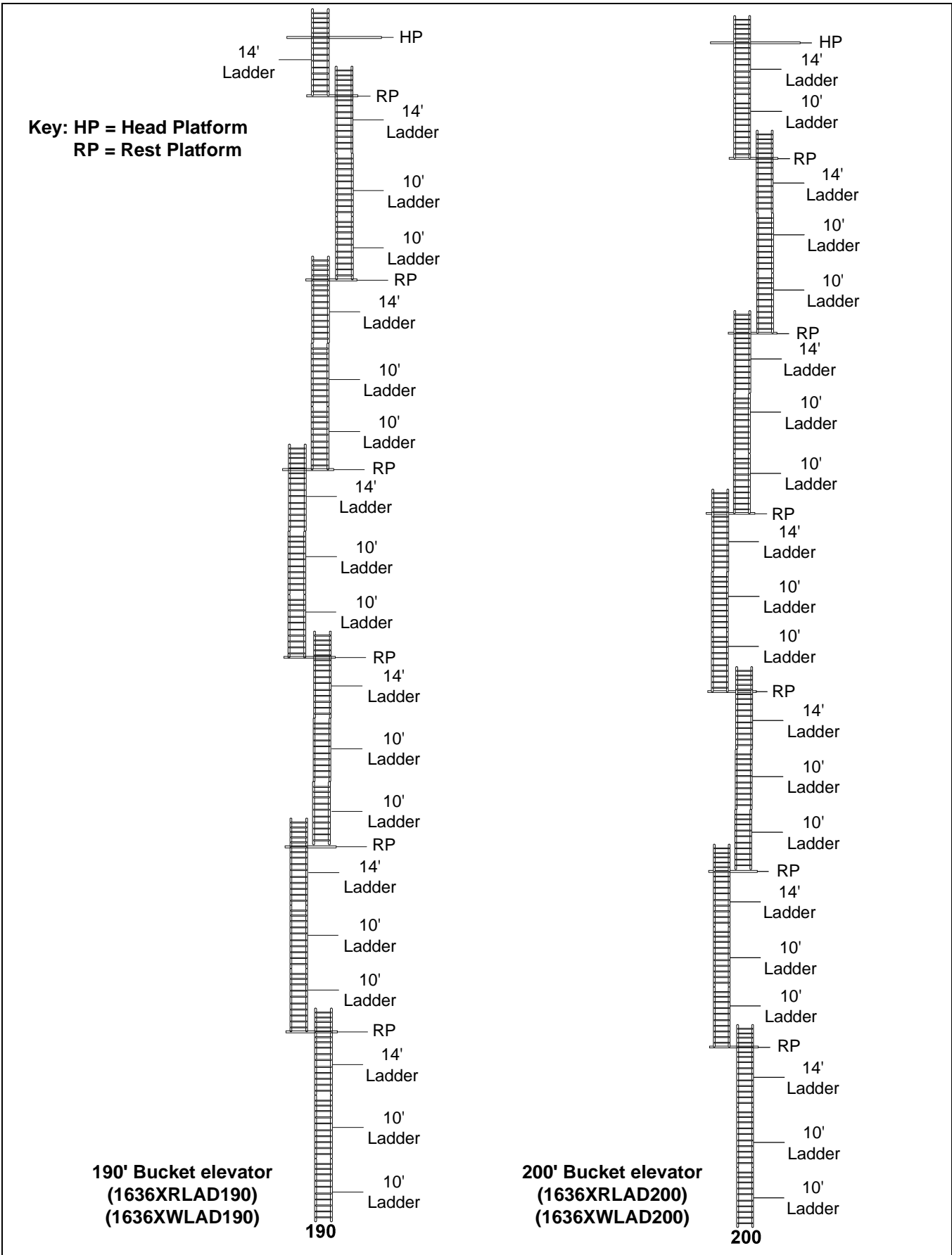

Figure 5G

5. Ladder Assembly

Typical Ladder/Cage Setup

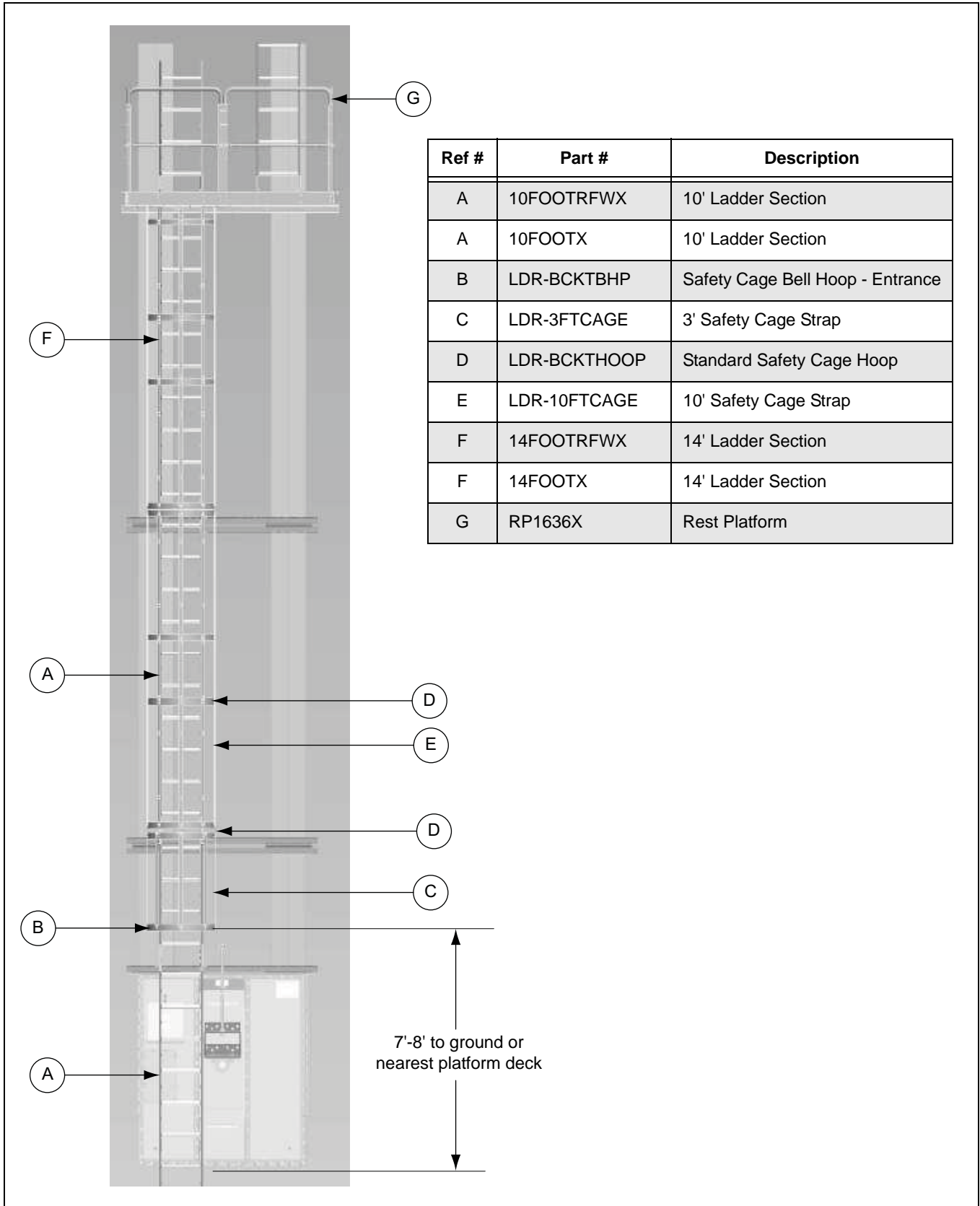

Figure 5H Typical Ladder/Cage Assembly Layout (30' Shown.)

Chapter 6: Tie Angles, Ladder Brackets and Safety Cages

Attach Tie Angle to Boot Trunking

1. On the NON-LADDER SIDE, attach tie angle to the trunking using 1/2" x 1" bolts. (See Figure 6A below and Figure 6B on Page 20.)
 - a. **For 16" Boot Tie Angle:** With lip of tie angle up and outward, align tie angle so that it extends beyond the trunking at each end. (See Figure 6A.)

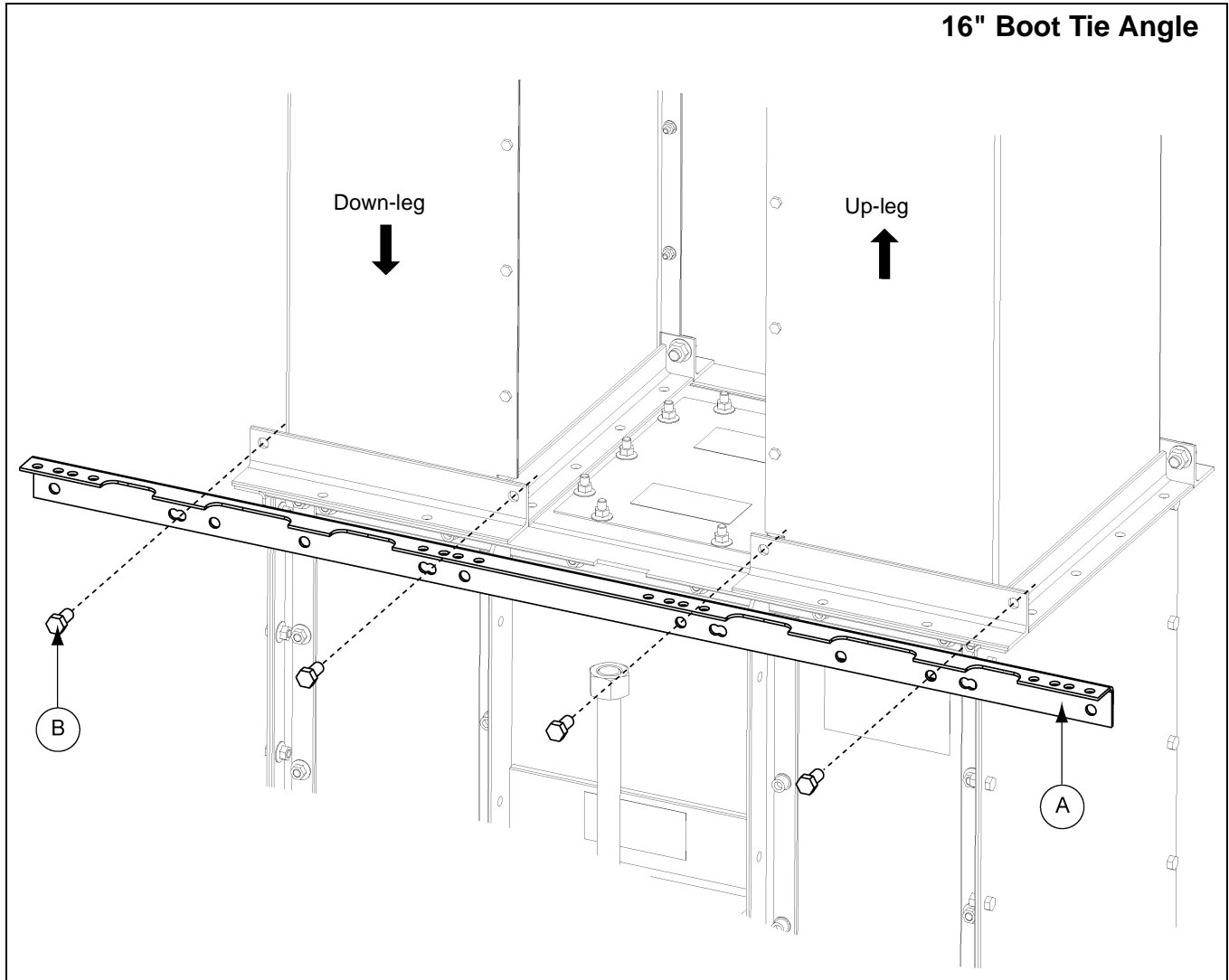

Figure 6A 16" Boot Tie Angle

Ref #	Part #	Description
A	BECT1640FX	Type "X" Tie Angle
B	S-7935	1/2" x 1" Bolt

6. Tie Angles, Ladder Brackets and Safety Cages

Attach Tie Angle to Boot Trunking (Continued)

- b. **For 24" Boot Tie Angle:** With lip of tie angle up and outward, align edge of tie angle to edge of trunking at down-leg end. With this alignment, tie angle will extend slightly beyond the edge of trunking at the up-leg end, as shown in [Figure 6B](#).

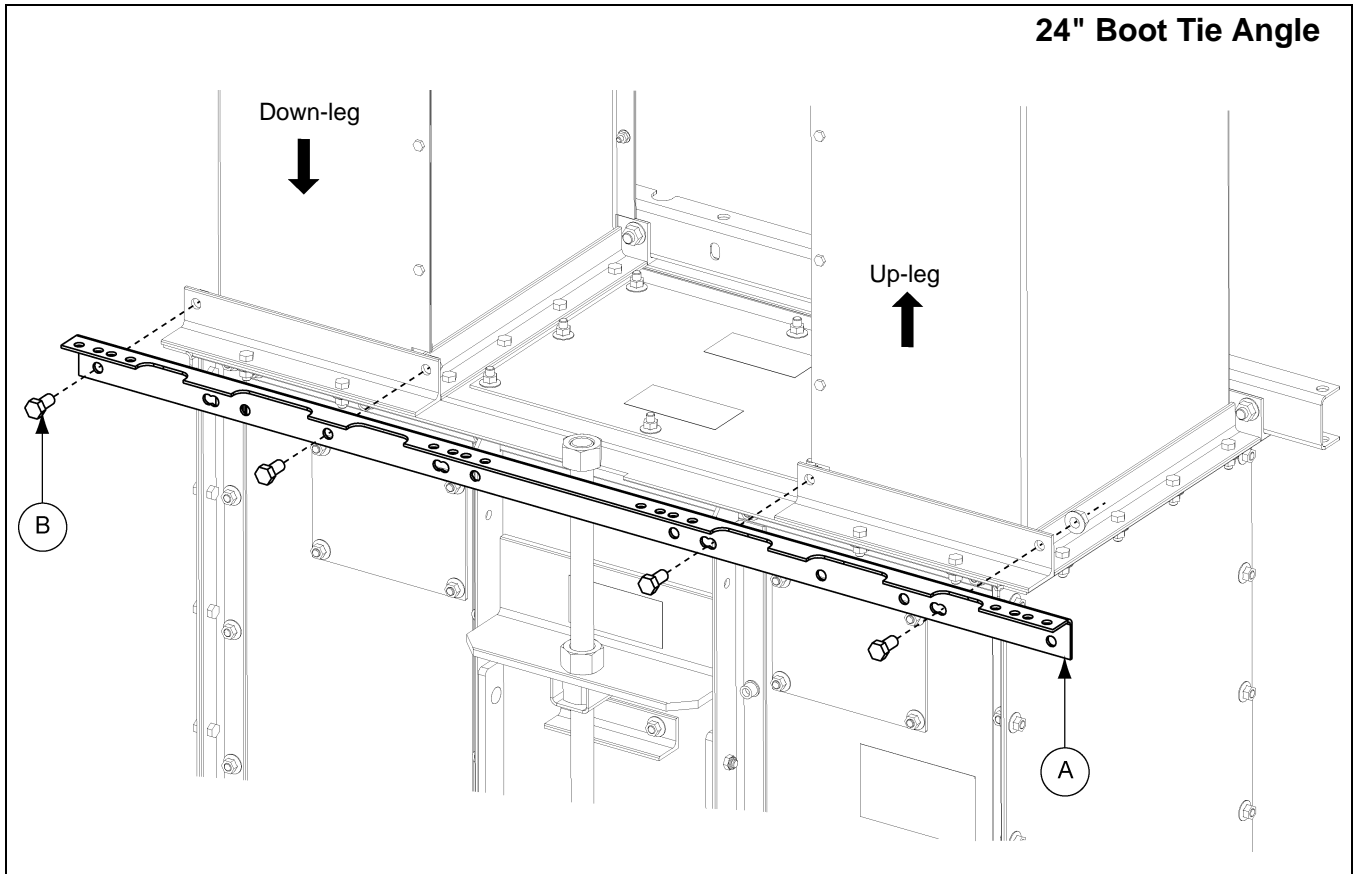

Figure 6B 24" Boot Tie Angle

Ref #	Part #	Description
A	BECT1640FX	Type "X" Tie Angle
B	S-7935	12" x 1" Bolt

Attach Boot Ladder Support Brackets and Boot Ladder Section

NOTE: Refer to ladder layout images, [Figure 5A-5G on Pages 11-17](#).

NOTE: Ladders can be mounted to either the up-leg or down-leg end of the elevator depending on the height and head platform hatch location.

NOTE: Both up-leg and down-leg bracket locations are shown in this manual. Actual installation location on either the up-leg or down-leg will be determined by owner preference.

1. Using the holes indicated based on bucket elevator size in [Figure 6C](#), attach ladder support brackets to boot tie angle using 3/8" x 1" hex bolts. Remember to double check if the ladder should start on the up-leg side or the down-leg side. ([See Figures 6C-6H on Pages 21-26](#).)
 - a. **16" Down-leg boot bracket:** Use 3/8" x 1" hex bolts to attach the ladder support brackets to the boot tie angle using the holes indicated in [Figure 6C](#). Note the outer bracket uses the outer most holes of the tie angle and the inner bracket will have two (2) empty holes beside it on the tie angle.

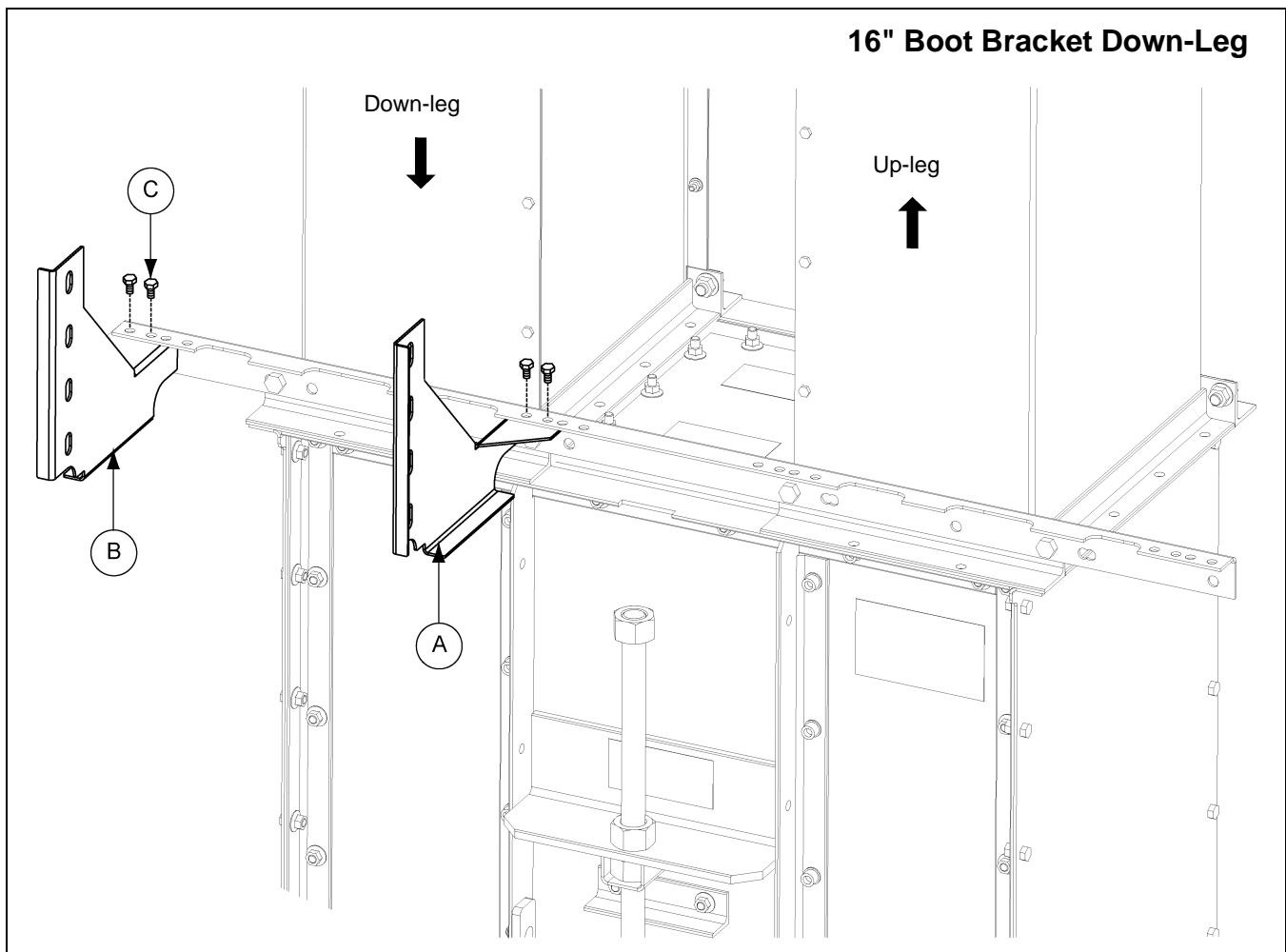

Figure 6C 16" Boot Bracket Down-Leg

Ref #	Part #	Description
A	LAD1648TRH	R.H. Side Trunk Support Bracket
B	LAD1648TLH	L.H. Side Trunk Support Bracket
C	S-7469	3/8" x 1" Hex Bolt

6. Tie Angles, Ladder Brackets and Safety Cages

Attach Boot Ladder Support Brackets and Boot Ladder Section (Continued)

- b. **16" Up-leg boot bracket:** Use 3/8" x 1" hex bolts to attach the ladder support brackets to the boot tie angle using the holes indicated in [Figure 6D](#). Note the outer bracket attaches to the tie angle with two (2) empty holes remain on the outside.

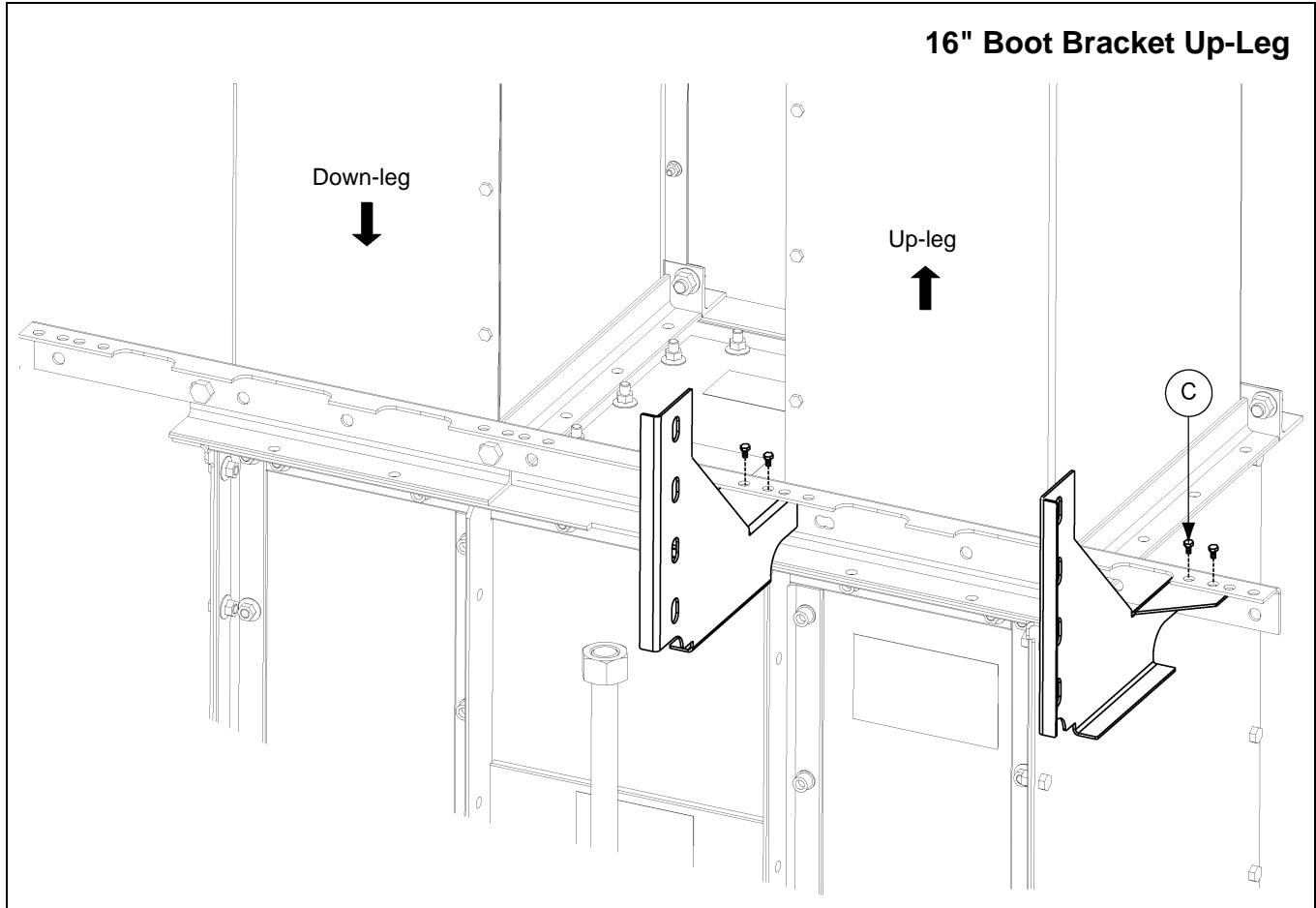

Figure 6D 16" Boot Bracket Up-Leg

Ref #	Part #	Description
C	S-7469	3/8" x 1" Hex Bolt

Attach Boot Ladder Support Brackets and Boot Ladder Section (Continued)

- c. **24" Down-leg boot bracket:** Use 3/8" x 1" hex bolts to attach the ladder support brackets to the boot tie angle using the holes indicated in [Figure 6E](#). Note the outer bracket will have two (2) empty holes to the outside of the connection at the tie angle.

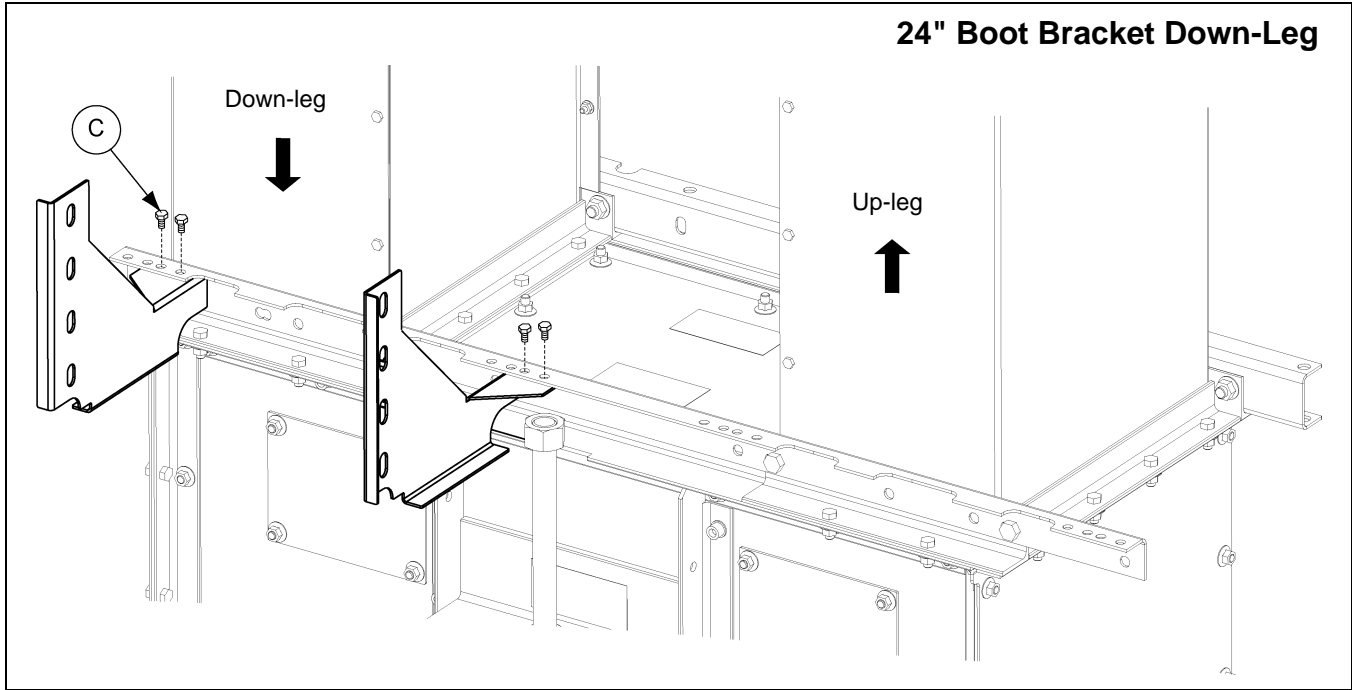

Figure 6E 24" Boot Bracket Down-Leg

Ref #	Part #	Description
C	S-7469	3/8" x 1" Hex Bolt

6. Tie Angles, Ladder Brackets and Safety Cages

Attach Boot Ladder Support Brackets and Boot Ladder Section (Continued)

- d. **24" Up-leg boot bracket:** Use 3/8" x 1" hex bolts to attach the ladder support brackets to the boot tie angle using the holes indicated in *Figure 6F*. Note the outer bracket uses the two (2) outer most set of holes on the tie angle.

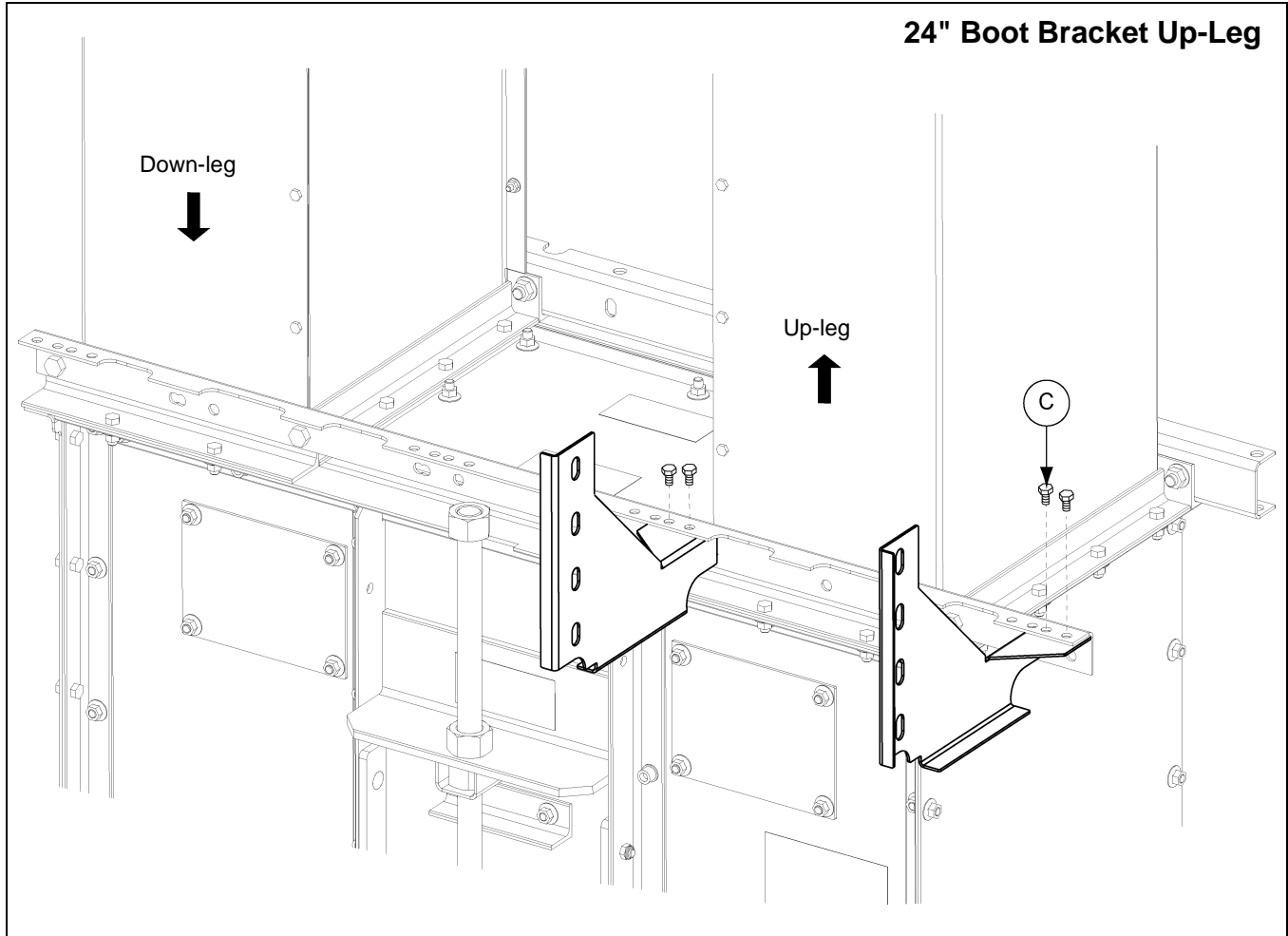

Figure 6F 24" Boot Bracket Up-Leg

Ref #	Part #	Description
C	S-7469	3/8" x 1" Hex Bolt

Install Boot Ladder Section

1. Trim a 10' ladder section to sit so that the first ladder rung is 12" from the ground. (See Figure 6G.)

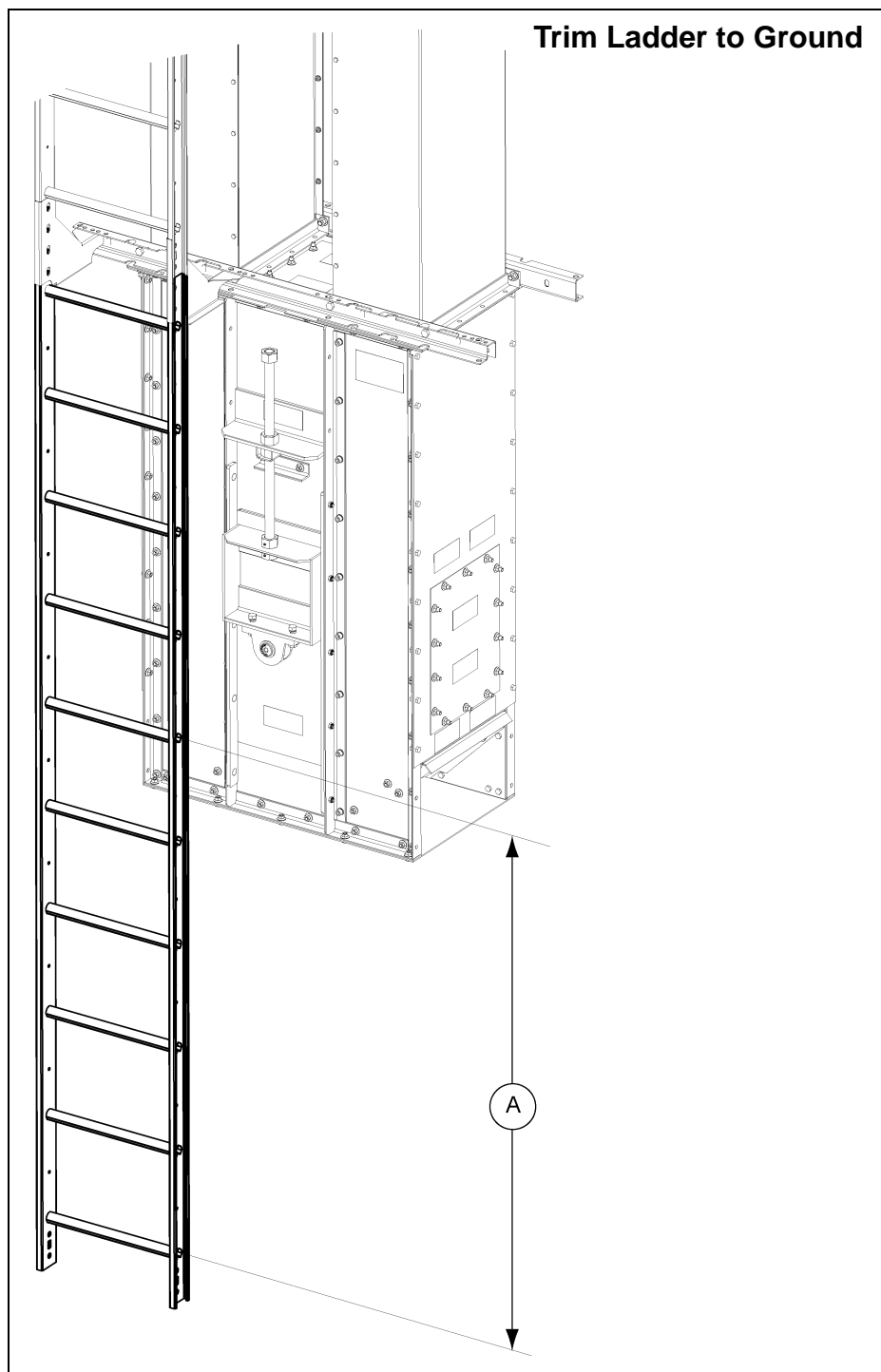

Figure 6G

Ref #	Description
A	Cut this section of the ladder so bottom rung of the ladder is 12" from the ground.

6. Tie Angles, Ladder Brackets and Safety Cages

Install Boot Ladder Section (Continued)

2. Attach trimmed ladder section to the left and right ladder brackets using 1/2" x 1" hex bolts through the bottom most set of holes.
3. Attach the next ladder section to the ladder brackets using 1/2" x 1" hex bolts through the top set of holes. (See Figure 6H.)

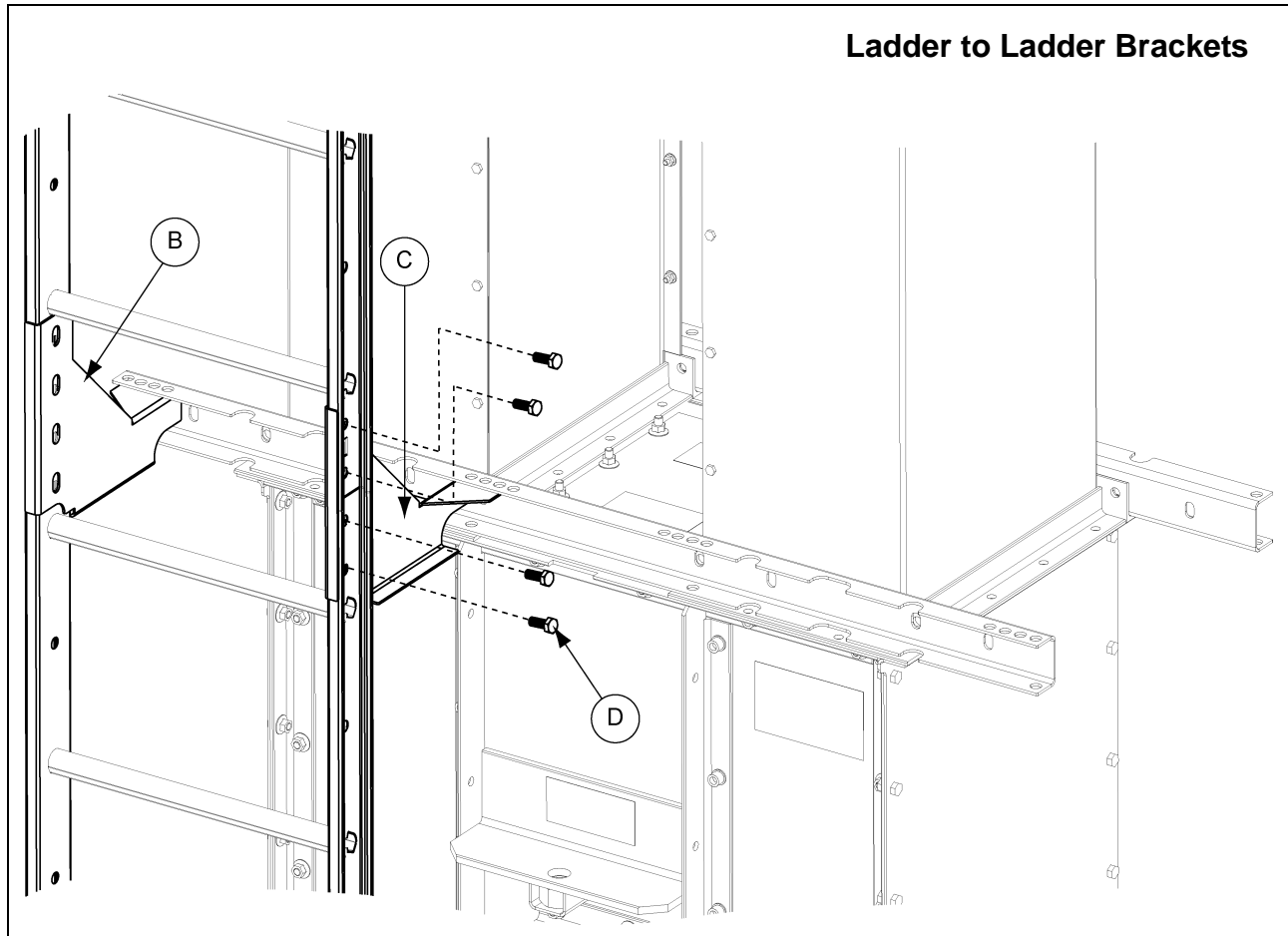

Figure 6H

Ref #	Part #	Description
B	LAD1648TLH	Trunk Support Bracket L.H. Side
C	LAD1648TRH	Trunk Support Bracket R.H. Side
D	S-7935	1/2" x 1" Hex Bolt

4. Secure the bottom of the ladder to the boot or ground. **NOTE:** Bracket for this step is not included.

Tie Angles to Trunking

1. On the LADDER SIDE, use 1/2" x 1" bolts. *See Figures 6I-6K on Pages 27-29* for the correct location of bolts for each elevator size.

Tie angle must be installed at every trunking seam. **NOTE:** *The bottom tie angle will be replaced with a rest platform tie angle (GECT1640FCRPX2) where a rest platform is to be installed. (See Figure 6I.)*

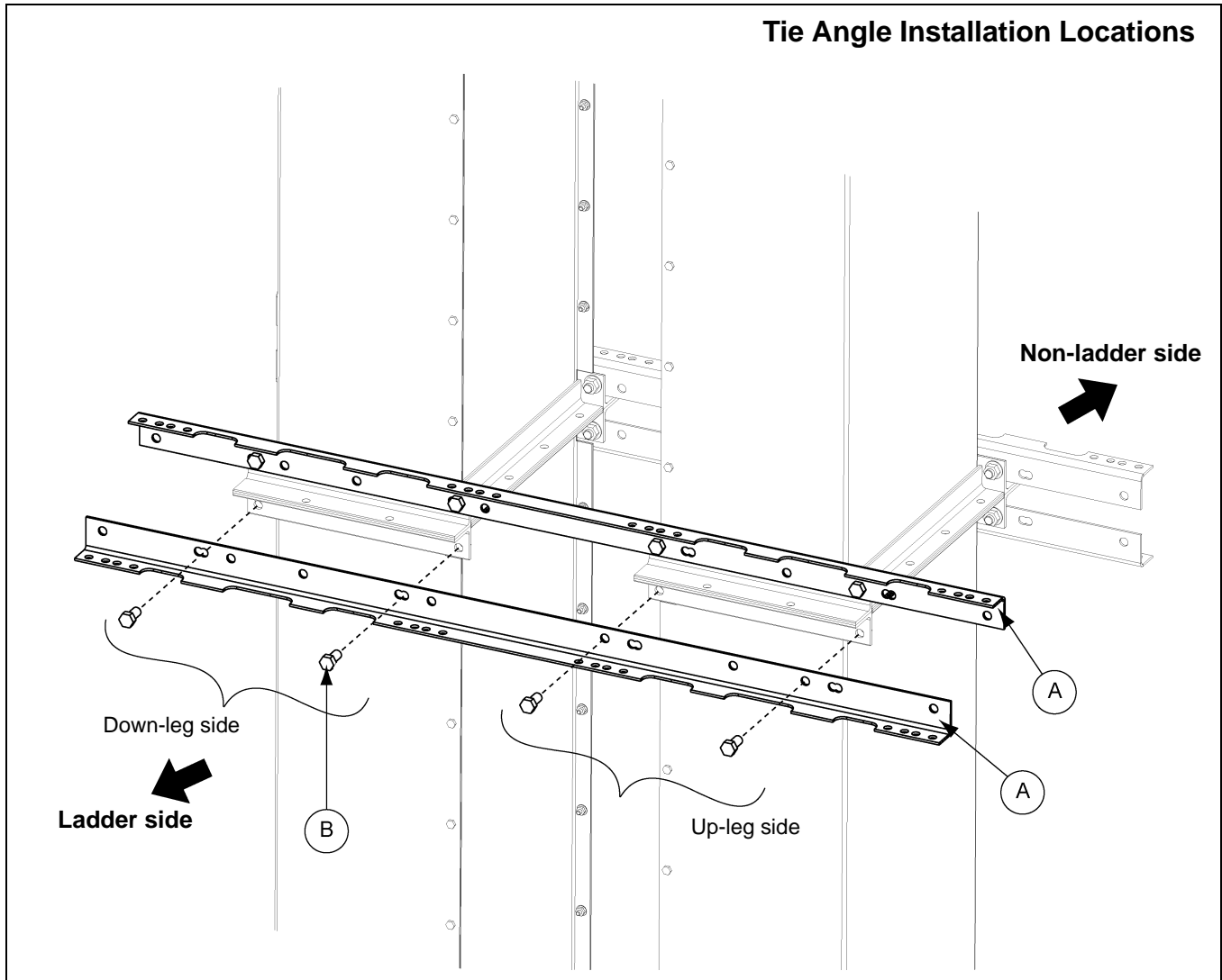

Figure 6I Tie Angle Installation Locations

Ref #	Part #	Description
A	BECT1640FX	16"-24" Type "X" Trunking Tie Angle
A	GECT1640FX	
B	S-7935	1/2" x 1" Hex Bolt

Tie Angles to Trunking (Continued)

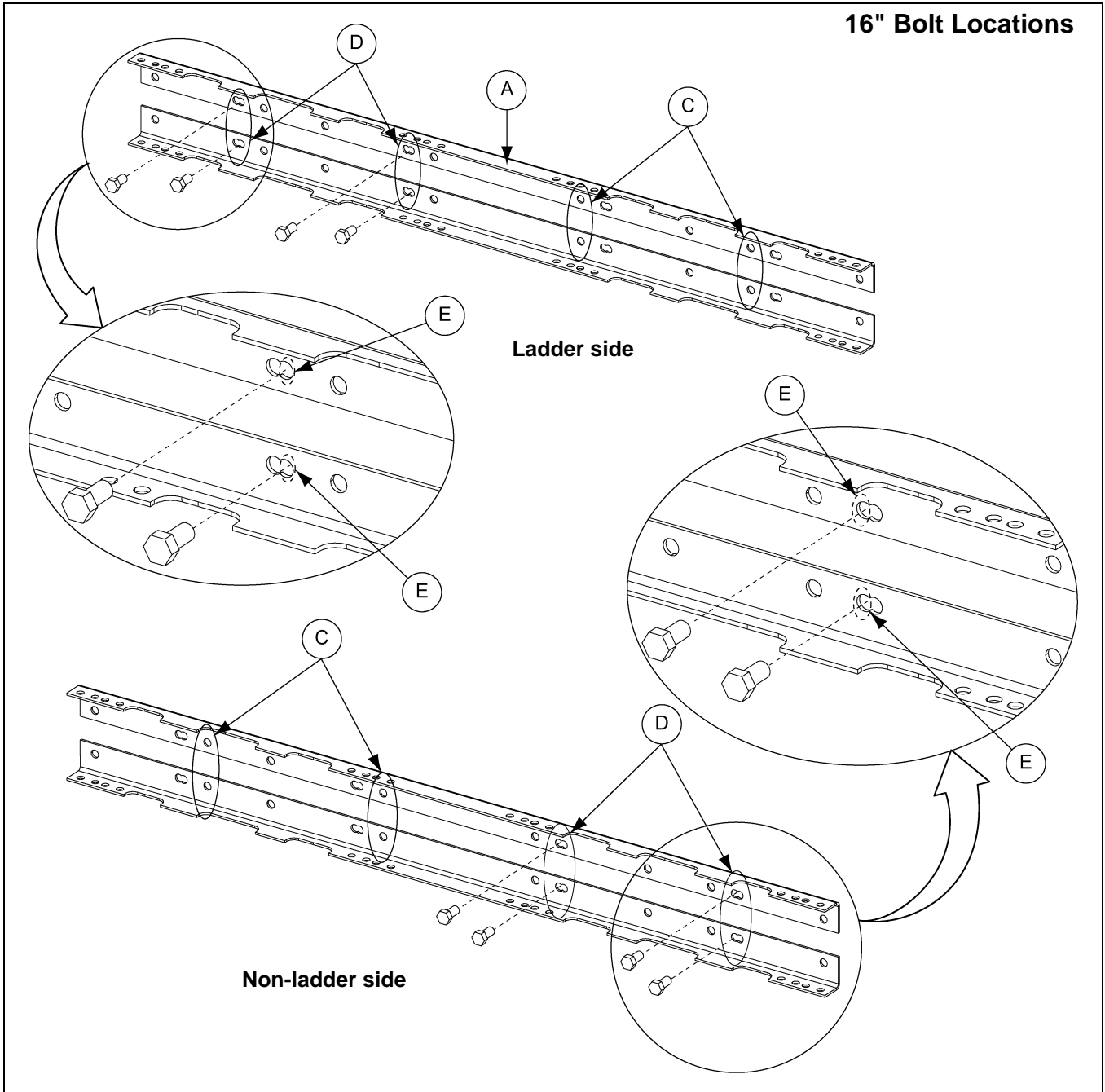

Figure 6J 16" Bucket Elevator Tie Angles to Trunking Bolt Locations

Ref #	Part #	Description
A	BECT1640FX	16"-24" Type "X" Trunking Tie Angle
A	GECT1640FX	
C		Up-Leg Set
D		Down-Leg Set
E		Install Bolt Here

Tie Angles to Trunking (Continued)

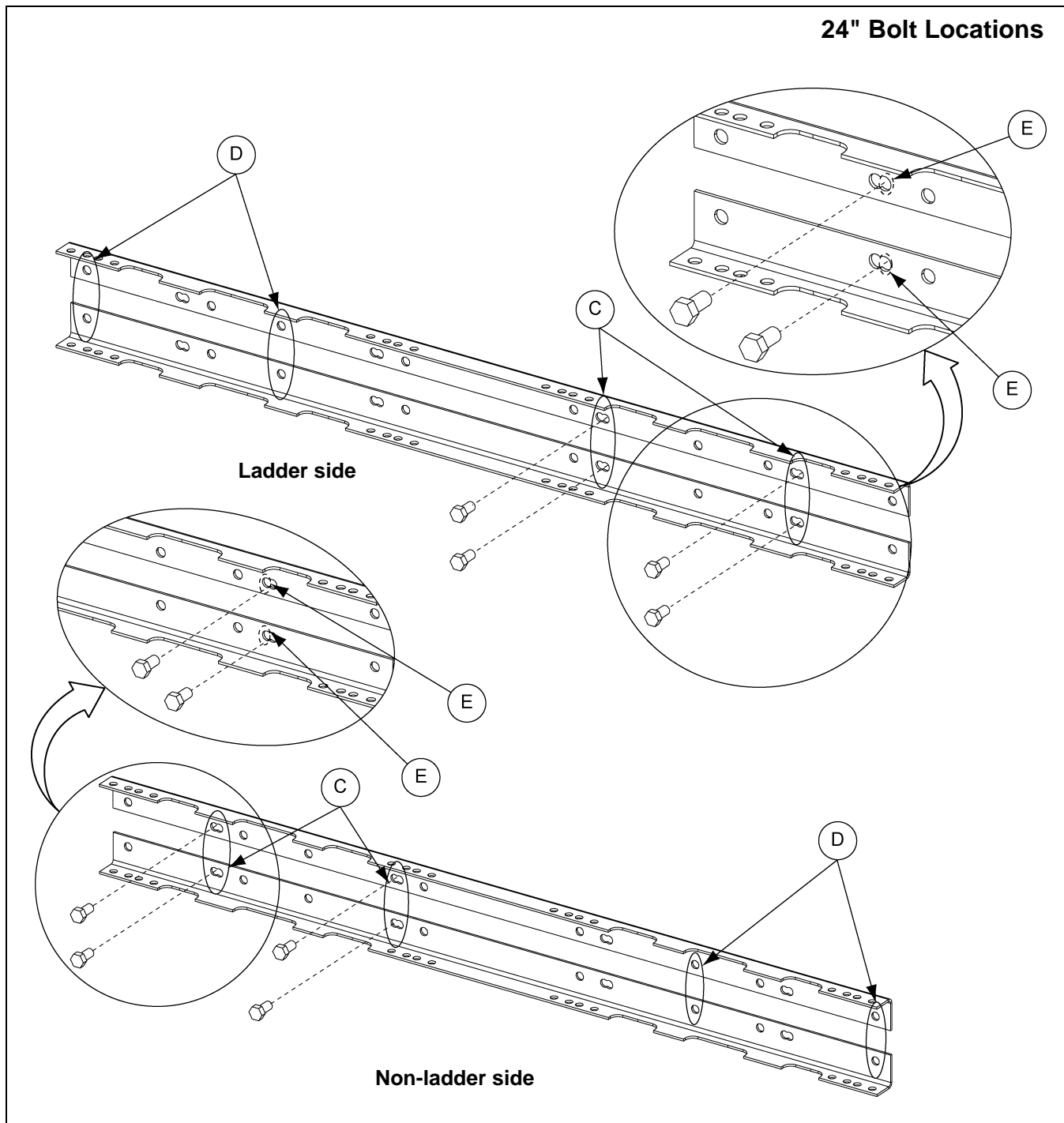

Figure 6K 24" Bucket Elevator Tie Angles to Trunking Bolt Locations

Ref #	Description
C	Up-Leg Set
D	Down-Leg Set
E	Install Bolt Here

6. Tie Angles, Ladder Brackets and Safety Cages

Ladder Support Brackets

1. Attach ladder support brackets to tie angle using 3/8" x 1" hex bolts (S-7469). Use the holes shown in [Figures 6L-6P on Pages 30-32](#) for each size elevator.
2. Mount the upper right and upper left hand ladder support brackets to the top tie angle with 3/8" bolts.
3. Mount the lower right hand and lower left hand ladder support brackets to the bottom tie angle with 3/8" bolts.
4. Secure the flanges of the ladder brackets together with 3/8" x 1" hex bolts.

NOTE: You will only use one set of ladder brackets, either the up-leg set or the down-leg set.

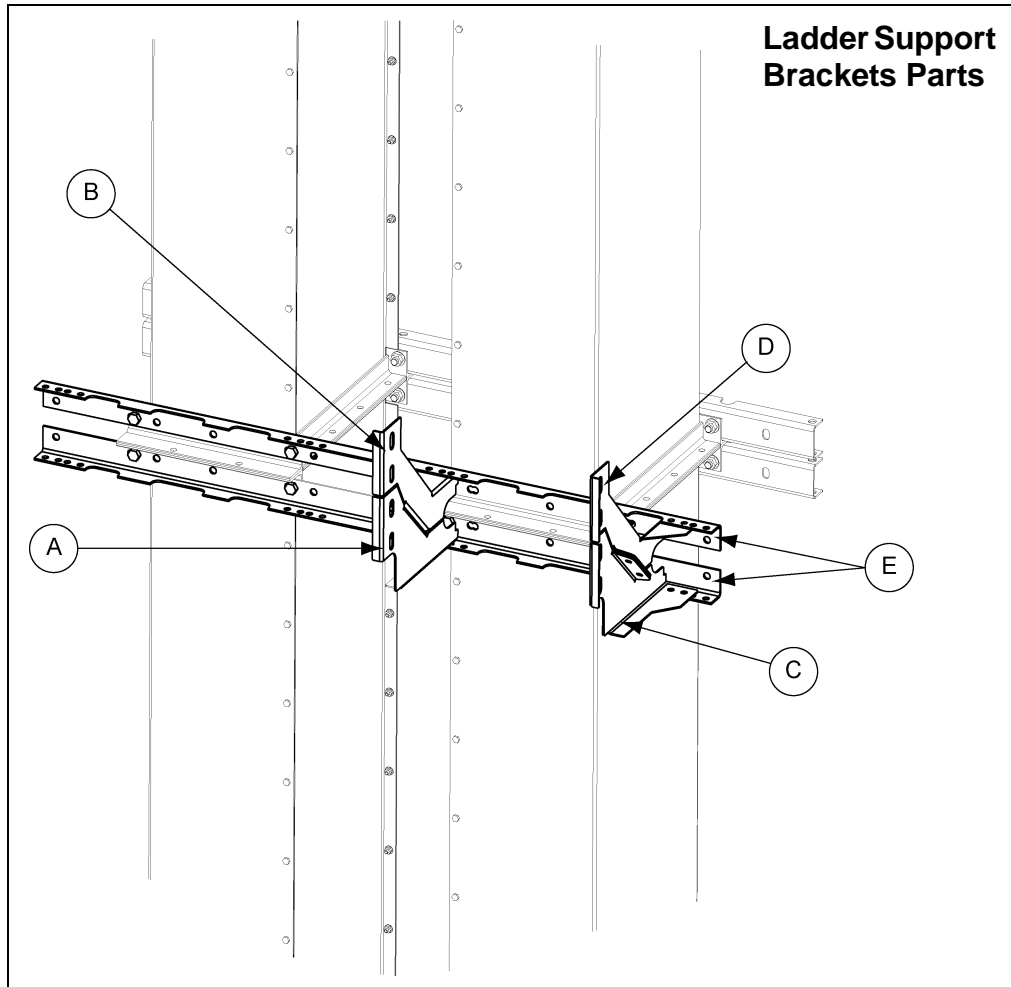

Figure 6L Ladder Support Bracket Parts

Ref #	Part #	Description
A	LAD1648TLH1	Bottom Trunk Support Bracket L.H. Side
B	LAD1648TLH2	Top Trunk Support Bracket L.H. Side
C	LAD1648TRH1	Bottom Trunk Support Bracket R.H. Side
D	LAD1648TRH2	Top Trunk Support Bracket R.H. Side
E		Tie Angles

Ladder Support Brackets (Continued)

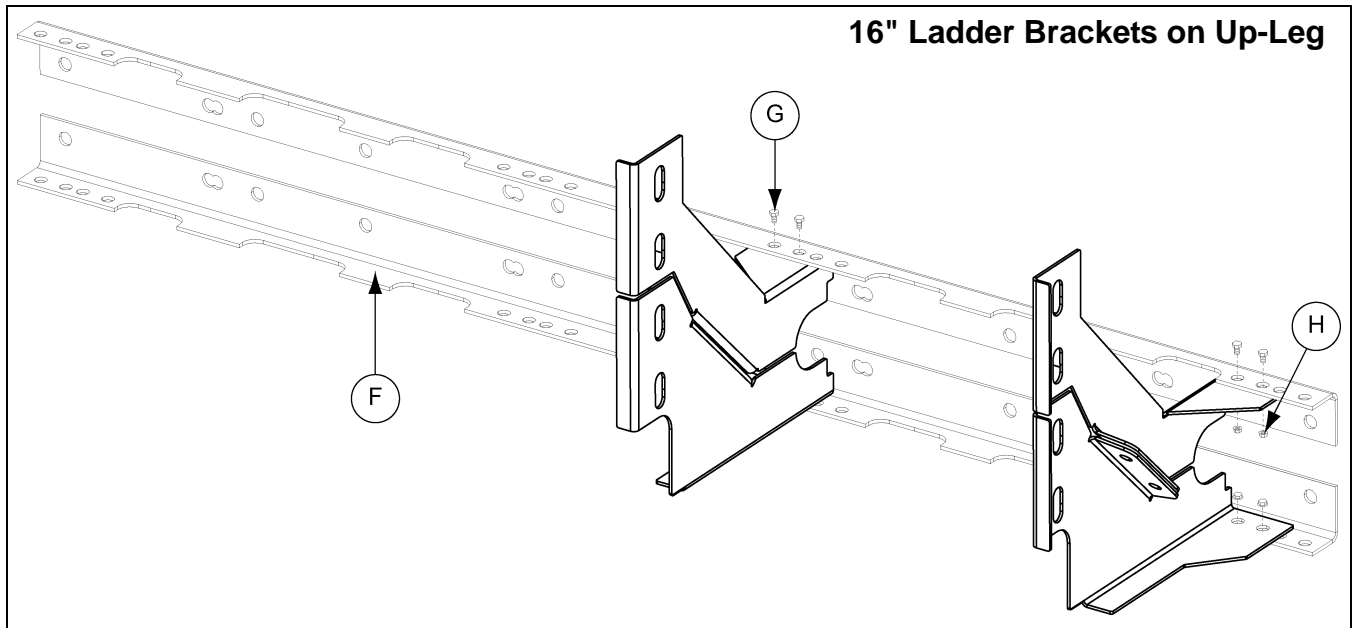

Figure 6M 16" Ladder Bracket Location for Up-Leg

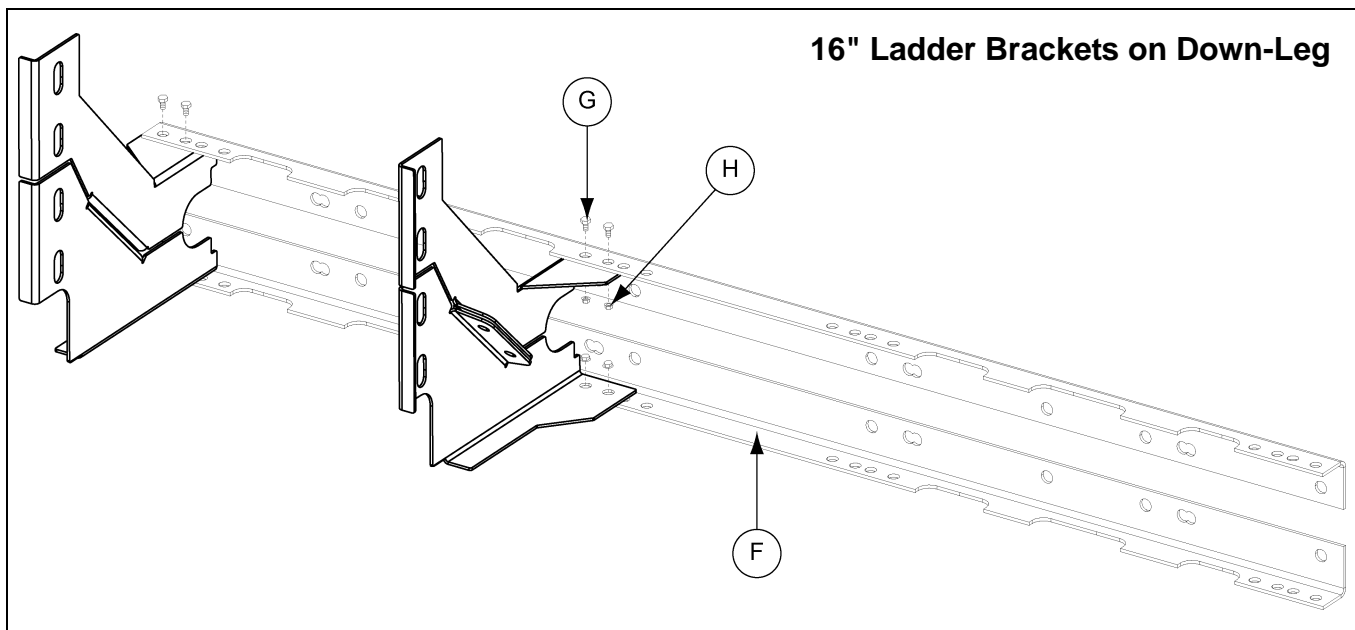

Figure 6N 16" Ladder Bracket Location for Down-Leg

Ref #	Part #	Description
F	BECT1640FX	16" Type "X" Trunking Tie Angle
F	GECT1640FX	
G	S-7469	3/8" x 1" Bolt
H	S-968	3/8" Flange Nut

Ladder Support Brackets (Continued)

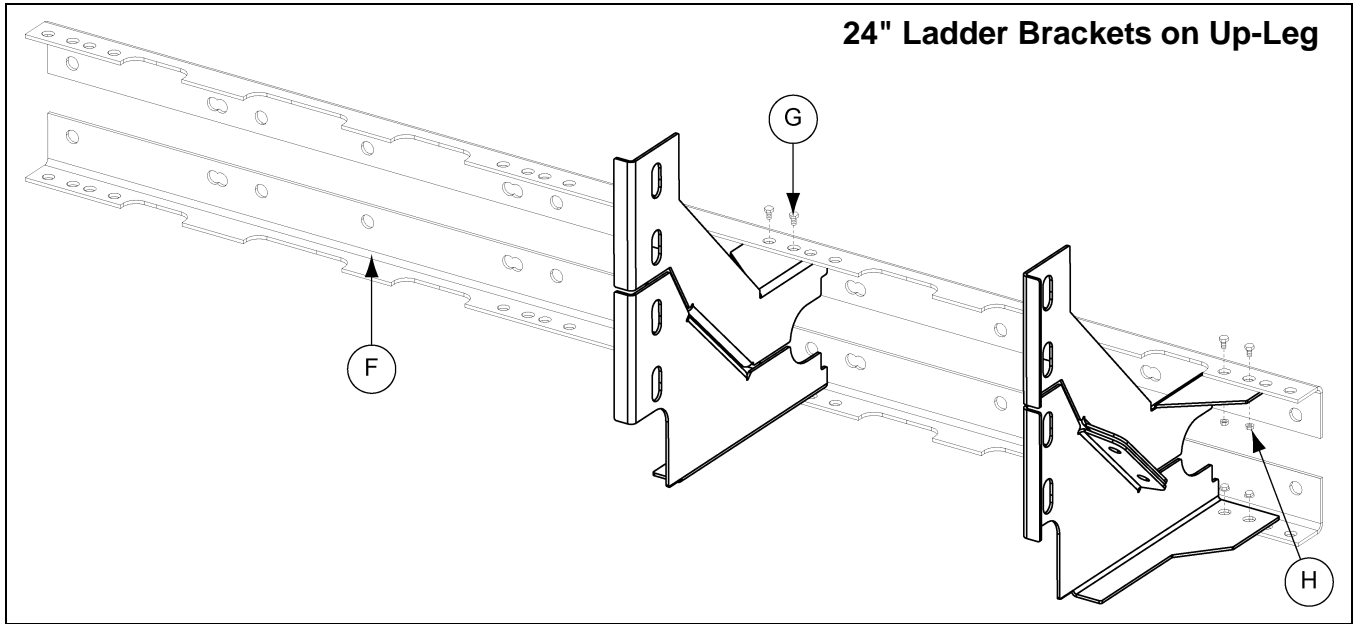

Figure 6O 24" Ladder Bracket Location for Up-Leg

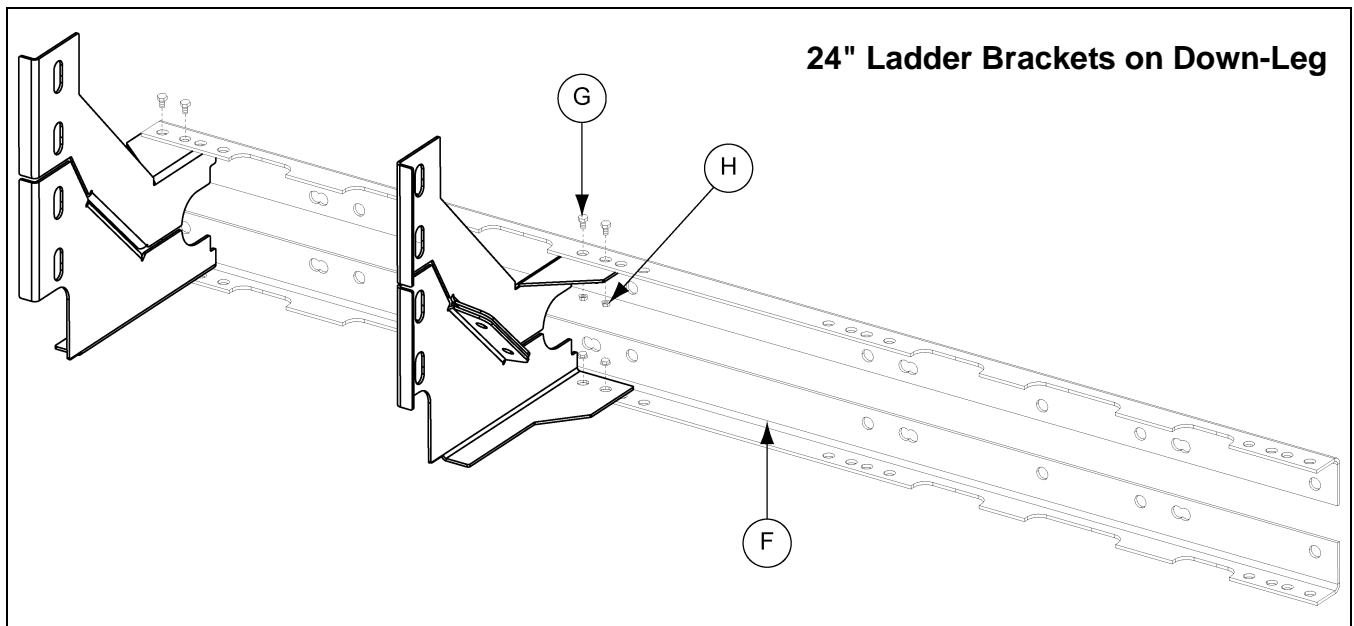

Figure 6P 24" Ladder Bracket Location for Down-Leg

Ref #	Part #	Description
F	BECT1640FX	24" Type "X" Trunking Tie Angle
F	GECT1640FX	
G	S-7469	3/8" x 1" Bolt
H	S-968	3/8" Flange Nut

Attach Ladders to Ladder Brackets

1. Attach ladder sections to the ladder brackets using 1/2" x 1" hex bolts (S-7935). (See Figure 6Q.)

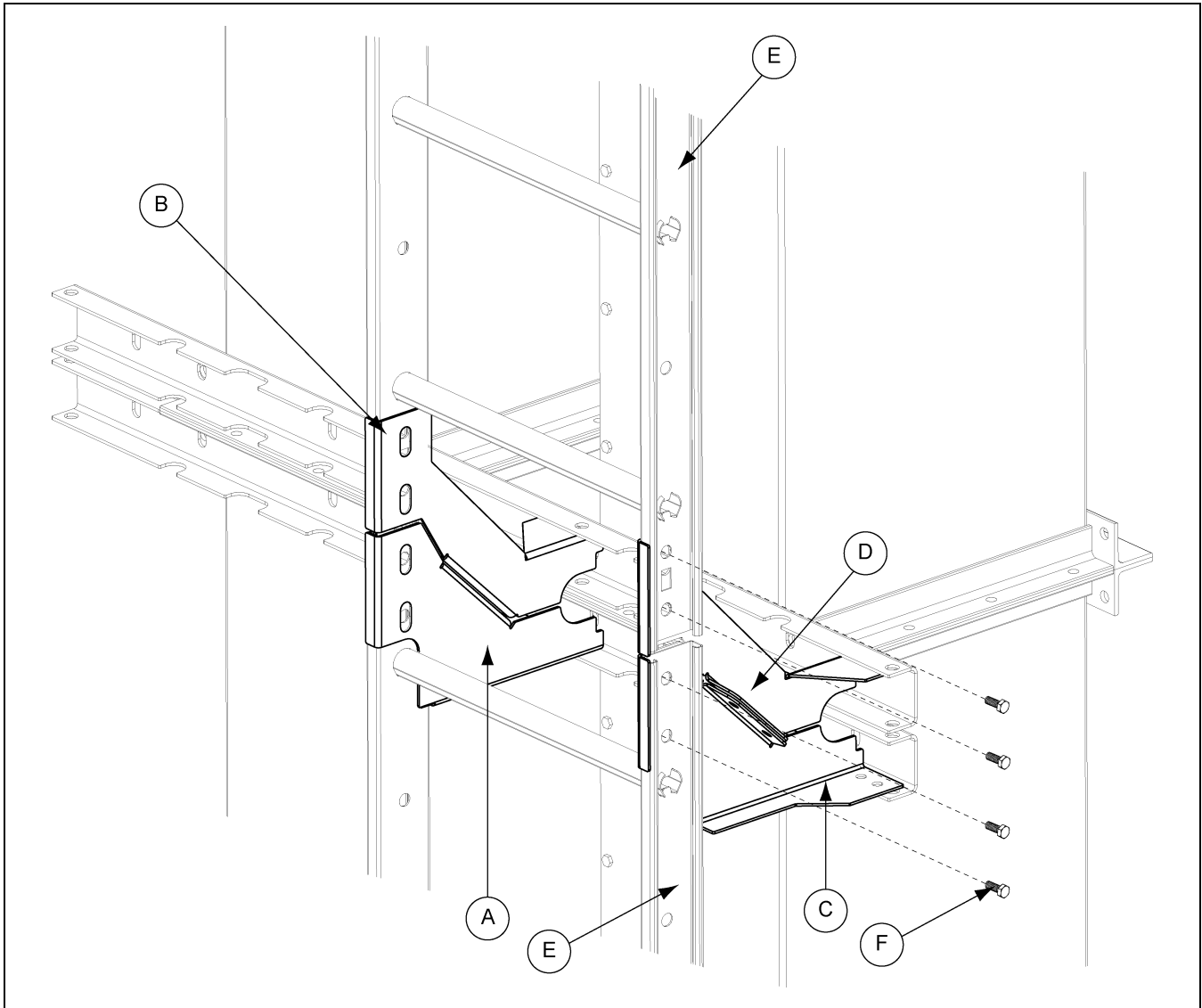

Figure 6Q

Ref #	Part #	Description
A	LAD1648TLH1	Bottom Trunk Support Bracket L.H. Side
B	LAD1648TLH2	Top Trunk Support Bracket L.H. Side
C	LAD1648TRH1	Bottom Trunk Support Bracket R.H. Side
D	LAD1648TRH2	Top Trunk Support Bracket R.H. Side
E	10FOOTRFX or 10FOOTX	10' Ladder Section
F	S-7935	1/2" x 1" Hex Bolt

6. Tie Angles, Ladder Brackets and Safety Cages

Safety Cage Installation

Safety cage entrance must be installed to the ladders within 7'-8' from the ground or platform deck.
(See Figure 6R.)

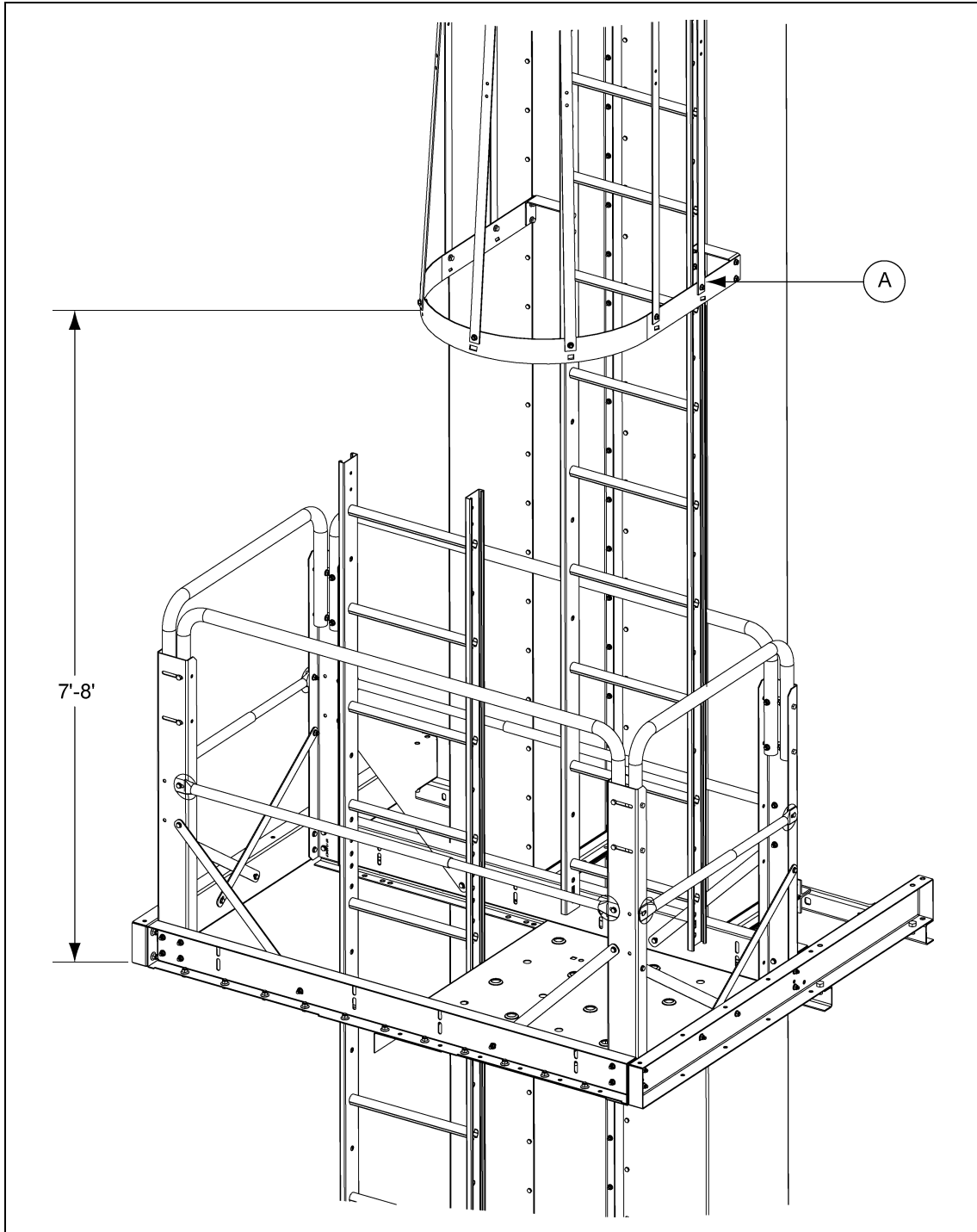

Figure 6R

Ref #	Description
A	Safety Cage

Install Safety Cage

Safety cages are 10' sections, with the exception of the 3' entrance section.

1. Locate safety cage hoops (LDR-BCKTBHP) along the ladder rails where the safety cage hoops will be installed. **NOTE:** *The end hoops of a 10' section are spaced 4' from the two (2) middle hoops, which are spaced 2' apart. See Figure 6S for spacing. (See Figure 6S.)*

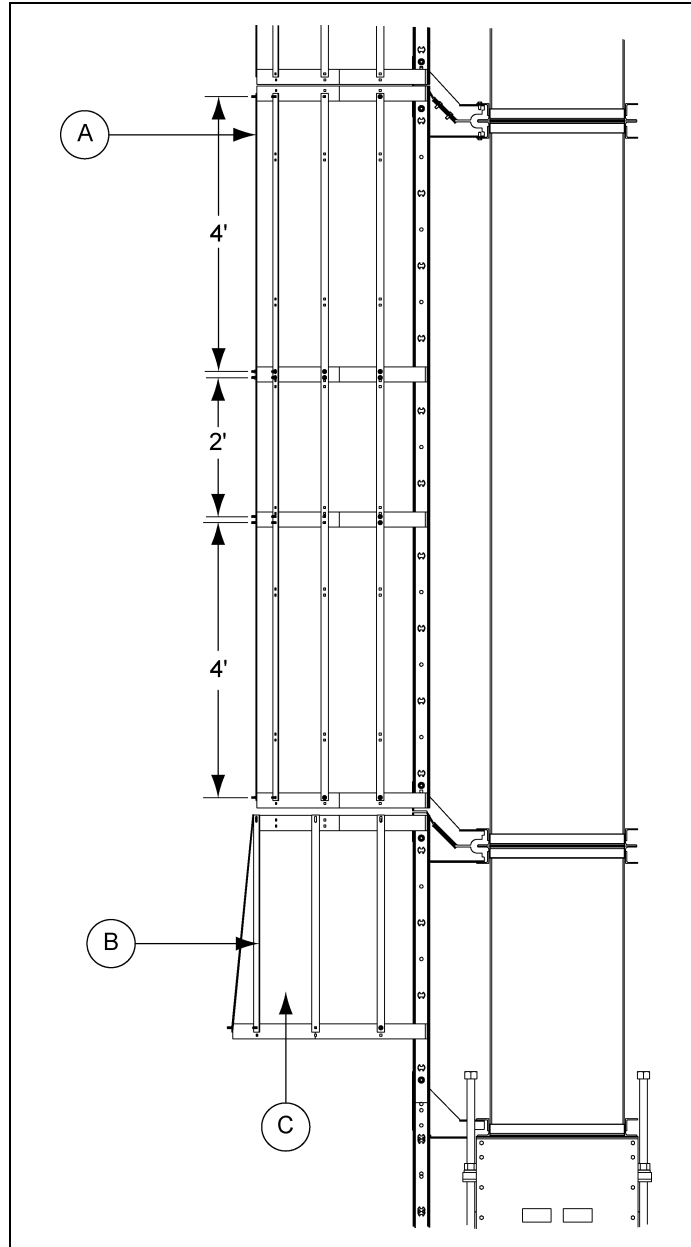

Figure 6S 10' Safety Cage Section

Ref #	Part #	Description
A	LDR-10FTCAGE	10' Safety Cage Strap
B	LDR-3FTCAGE	3' Safety Cage Strap
C		3' Safety Cage Entrance Section

6. Tie Angles, Ladder Brackets and Safety Cages

Install Safety Cage (Continued)

2. Attach safety cage hoops to ladder using 1/2" x 1" bolts and nuts. (See Figure 6T.)

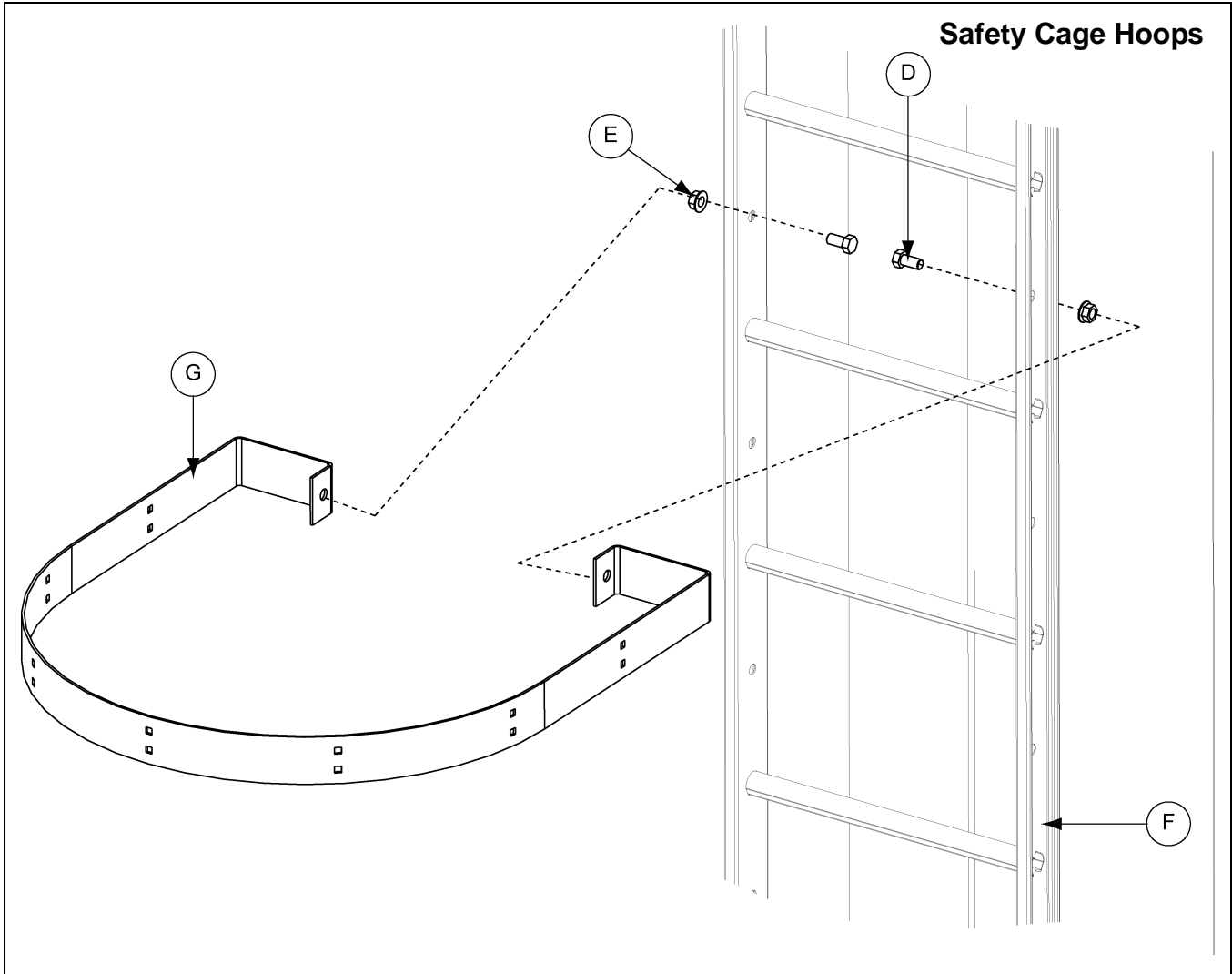

Figure 6T

Ref #	Part #	Description
D	S-7935	1/2" x 1" HHCS Bolt
E	S-8506	1/2" Flange Nut
F	10FOOTRFWX or 10FOOTX	10' Ladder Section
G		Safety Cage Hoop

Install Safety Cage (Continued)

3. Install the seven (7) 10' safety cage straps along the safety cage hoops using 5/16" x 3/4" bolts and nuts. **NOTE:** Bolt heads should be to the inside of the hoop. (See Figure 6U.)

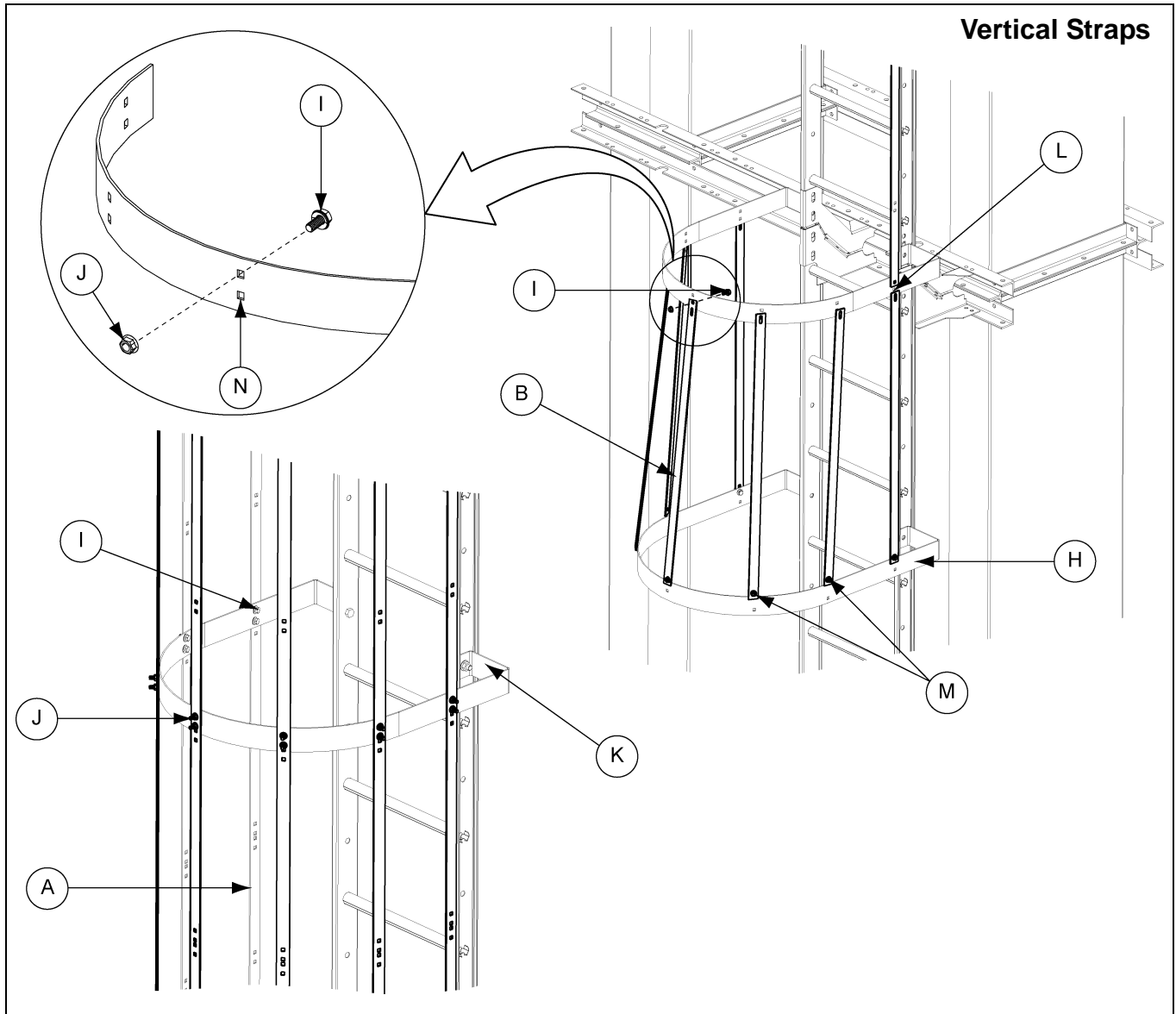

Figure 6U

Ref #	Part #	Description
A	LDR-10FTCAGE	10' Safety Cage Strap
B	LDR-3FTCAGE	3' Safety Cage Strap
H	LDR-BCKTBHP	Safety Cage Hoop Entrance
I	S-7645	5/16" x 3/4" Bolt
J	S-10268	5/16" Flange Nut
K	LDR-BCKTHOOP	Safety Cage Hoop Standard
L		Bottom Holes
M		Top Holes
N		Leave these hole open for vertical bars.

Chapter 7: Rest Platform

Rest Platform Tie Angles to Bucket Elevators

1. Install rest platform tie angles to the lower trunking on both the ladder side and non-ladder side of the trunking. Use 1/2" x 1" bolts through the bolt holes indicated for the bucket elevator size being installed. (See Figure 7A.)

NOTE: Bolt hole starting location on left side of tie angle is marked with the bucket size.

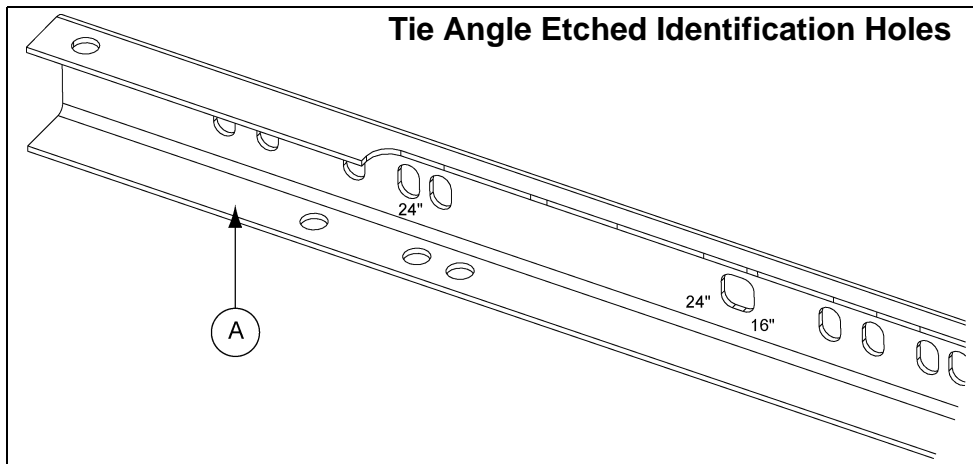

Figure 7A Tie Angle with Etched Numbers

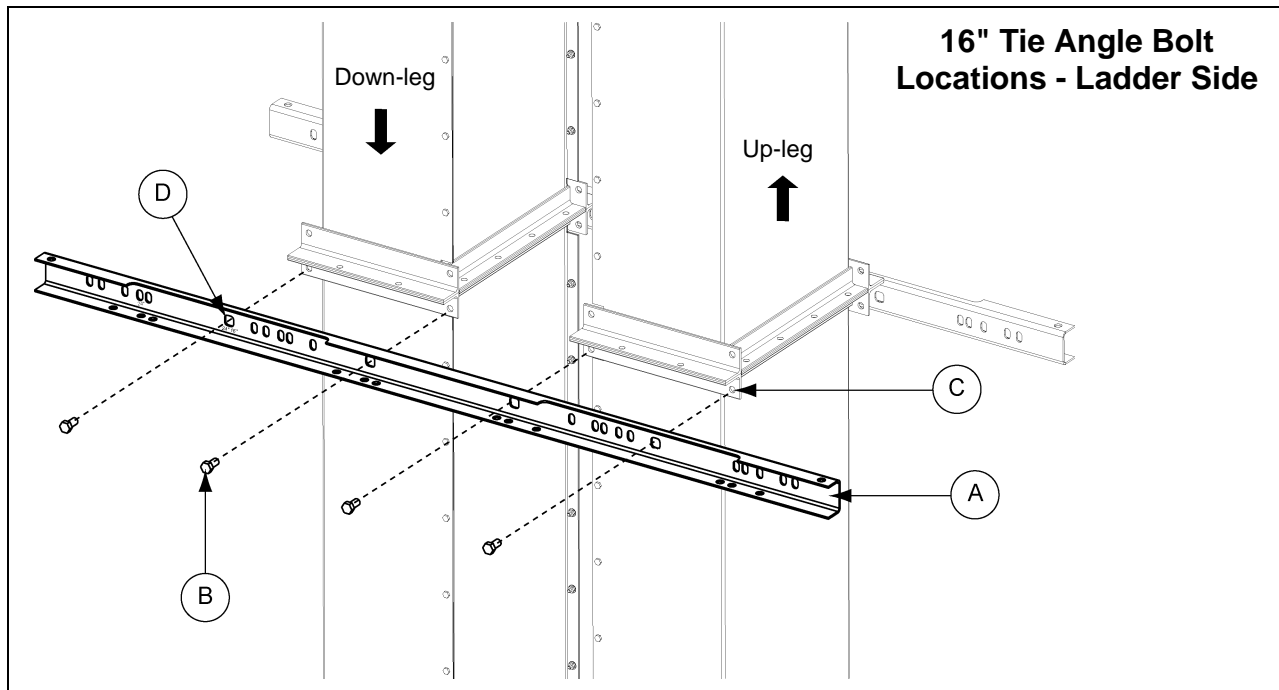

Figure 7B 16" Rest Platform Tie Angle Bolt Locations - Ladder Side

Ref #	Part #	Description
A	GECT1640FCRPX2	16"-24" Rest Platform Tie Angle
B	S-7935	1/2" x 1" Bolt

Ref #	Part #	Description
C	S-8506	1/2" Flange Nut
D		Hole Marked 24" 16". Use Side Marked 16".

Rest Platform Tie Angles to Bucket Elevators (Continued)

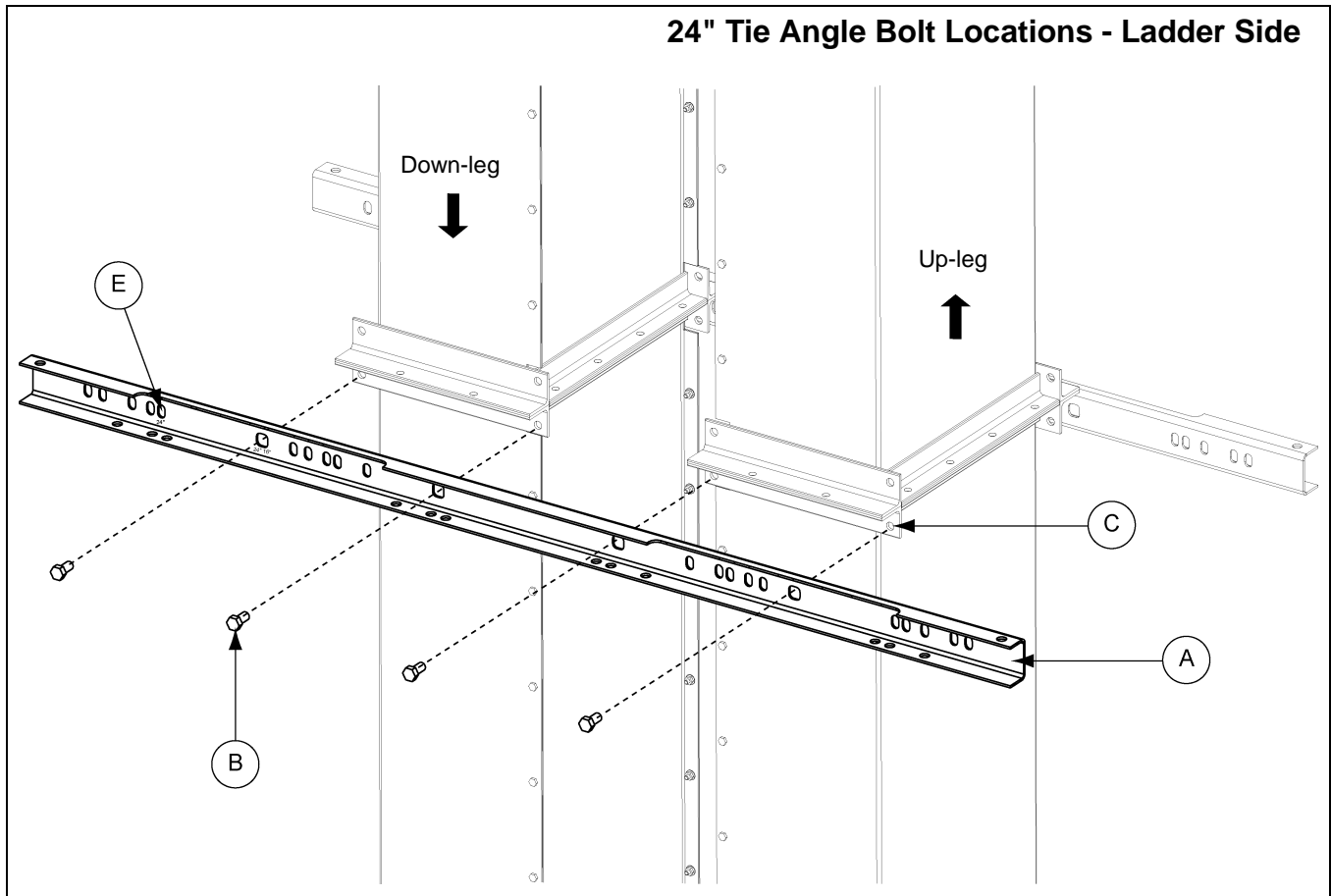

Figure 7C 24" Rest Platform Tie Angle Bolt Locations - Ladder Side

Ref #	Part #	Description
A	GECT1640FCRPX2	16"-24" Rest Platform Tie Angle
B	S-7935	1/2" x 1" Bolt
C	S-8506	1/2" Flange Nut
E		Hole Marked 24" 16". Use Side Marked 24".

Rest Platform Tie Angles to Bucket Elevators (Continued)

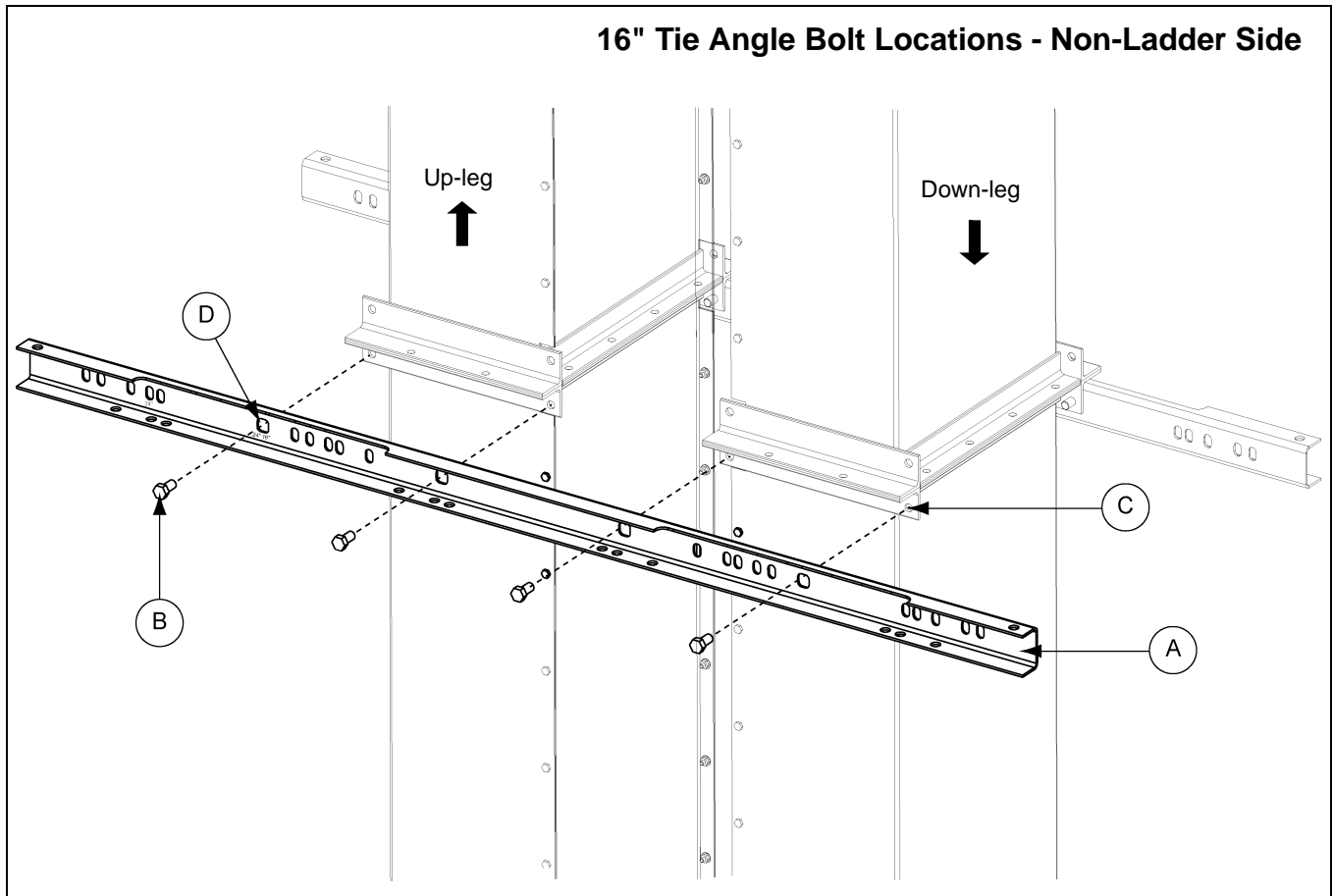

Figure 7D 16" Rest Platform Tie Angle Bolt Locations - Non-Ladder Side

Ref #	Part #	Description
A	GECT1640FCRPX2	16"-24" Rest Platform Tie Angle
B	S-7935	1/2" x 1" Bolt
C	S-8506	1/2" Flange Nut
D		Hole Marked 24" 16". Use Side Marked 16".

Rest Platform Tie Angles to Bucket Elevators (Continued)

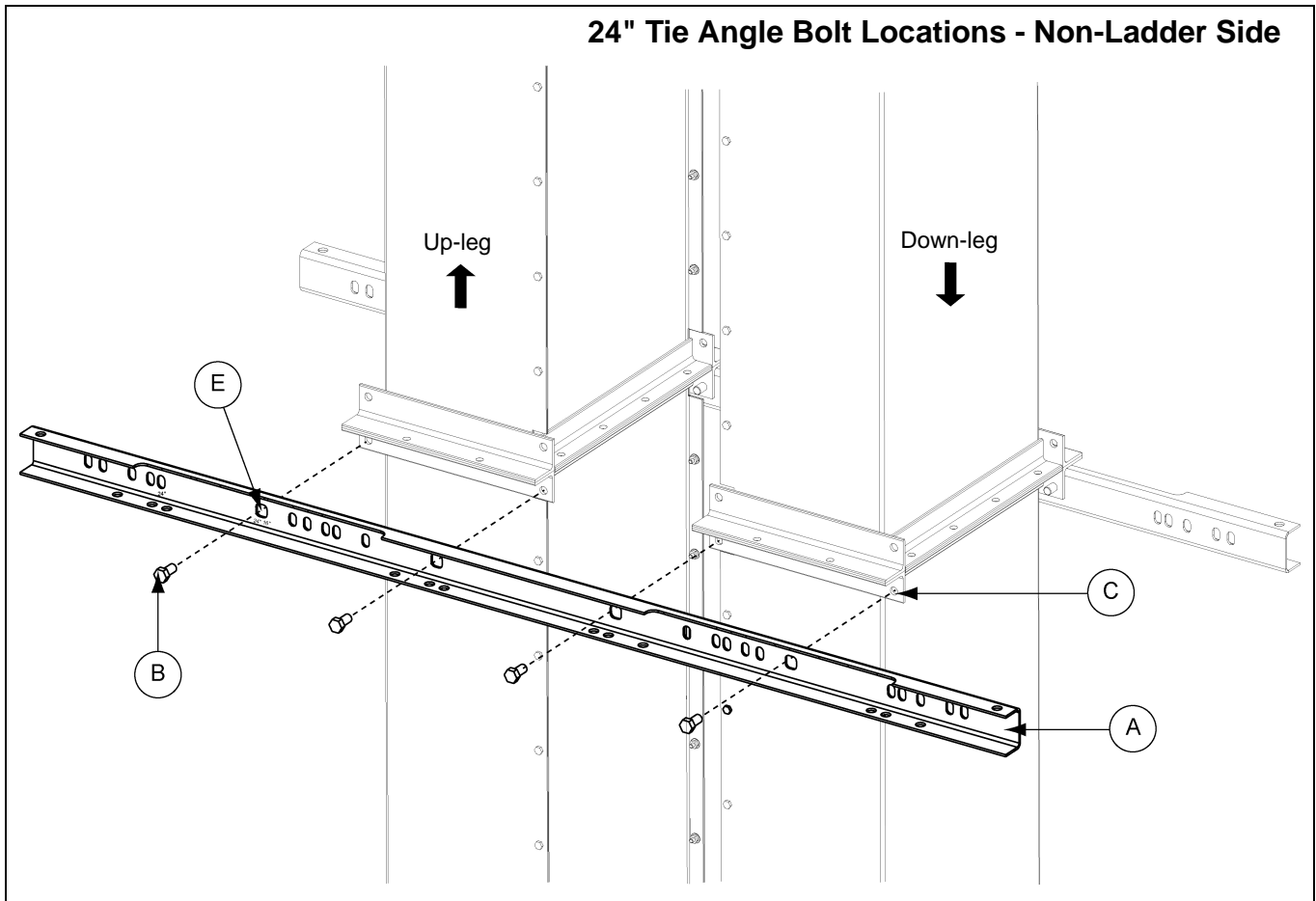

Figure 7E 24" Rest Platform Tie Angle Bolt Locations - Non-Ladder Side

Ref #	Part #	Description
A	GECT1640FCRPX2	16"-24" Rest Platform Tie Angle
B	S-7935	1/2" x 1" Bolt
C	S-8506	1/2" Flange Nut
E		Hole Marked 24" 16". Use Side Marked 24".

7. Rest Platform

Attach Rest Platform Channel to the Rest Platform Tie Angle

1. Connect rest platform mounting channels to the rest platform tie angles using 1/2" x 1" bolts. Bolt hole locations for 16"-24" bucket elevator will be the same. (See Figure 7F.)

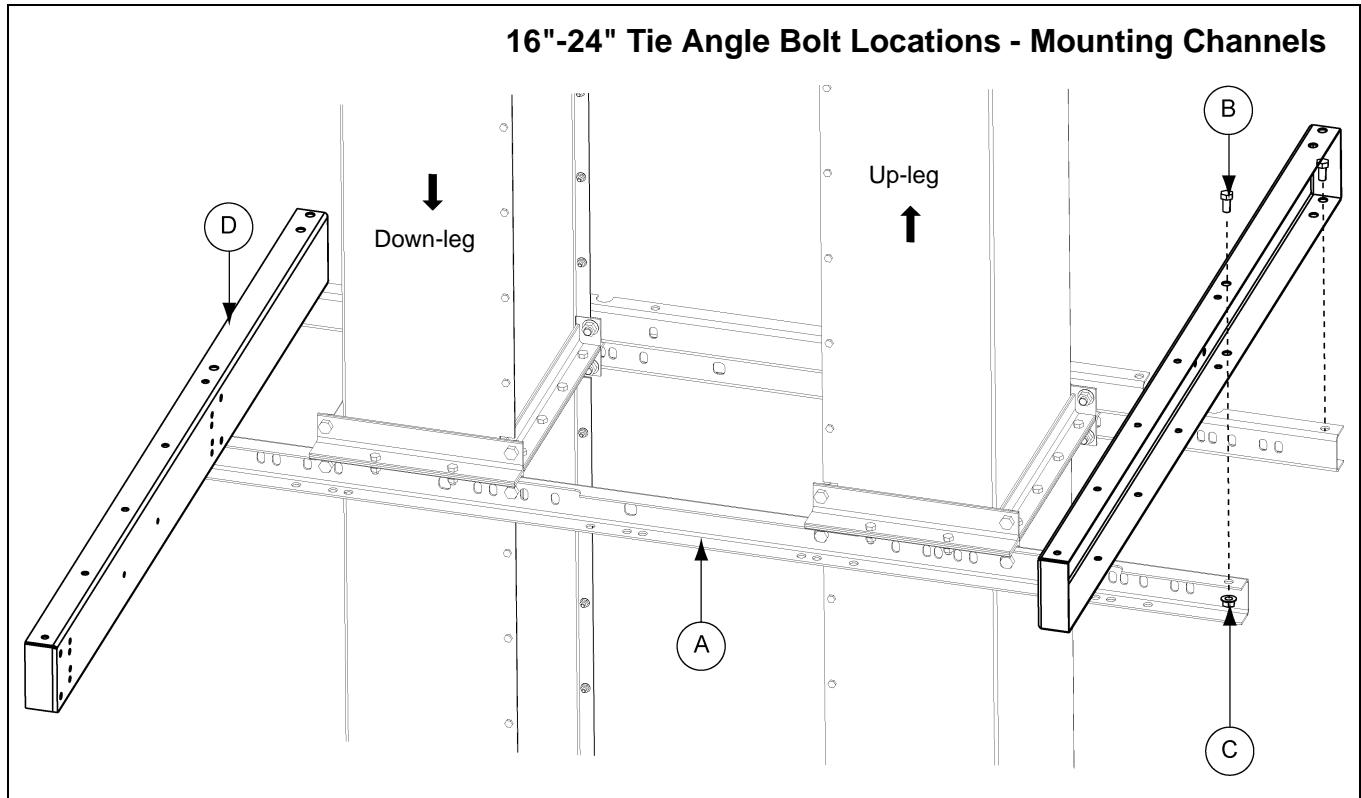

Figure 7F Bolt hole locations for 16"-24" rest platform mounting channels to tie angles.

Ref #	Part #	Description
A	GECT1640FCRPX2	16"-24" Rest Platform Tie Angle
B	S-7935	1/2" x 1" Bolt
C	S-8506	1/2" Flange Nut
D	RP1636MCX	16"-36" Rest Platform Mounting Channel

Rest Platform Cross Channel to Rest Platform Mounting Channels

1. Place the rest platform cross channels between the rest platform mounting channels and connect those using 3/8" x 3/4" hex bolts. (See Figure 7G.)

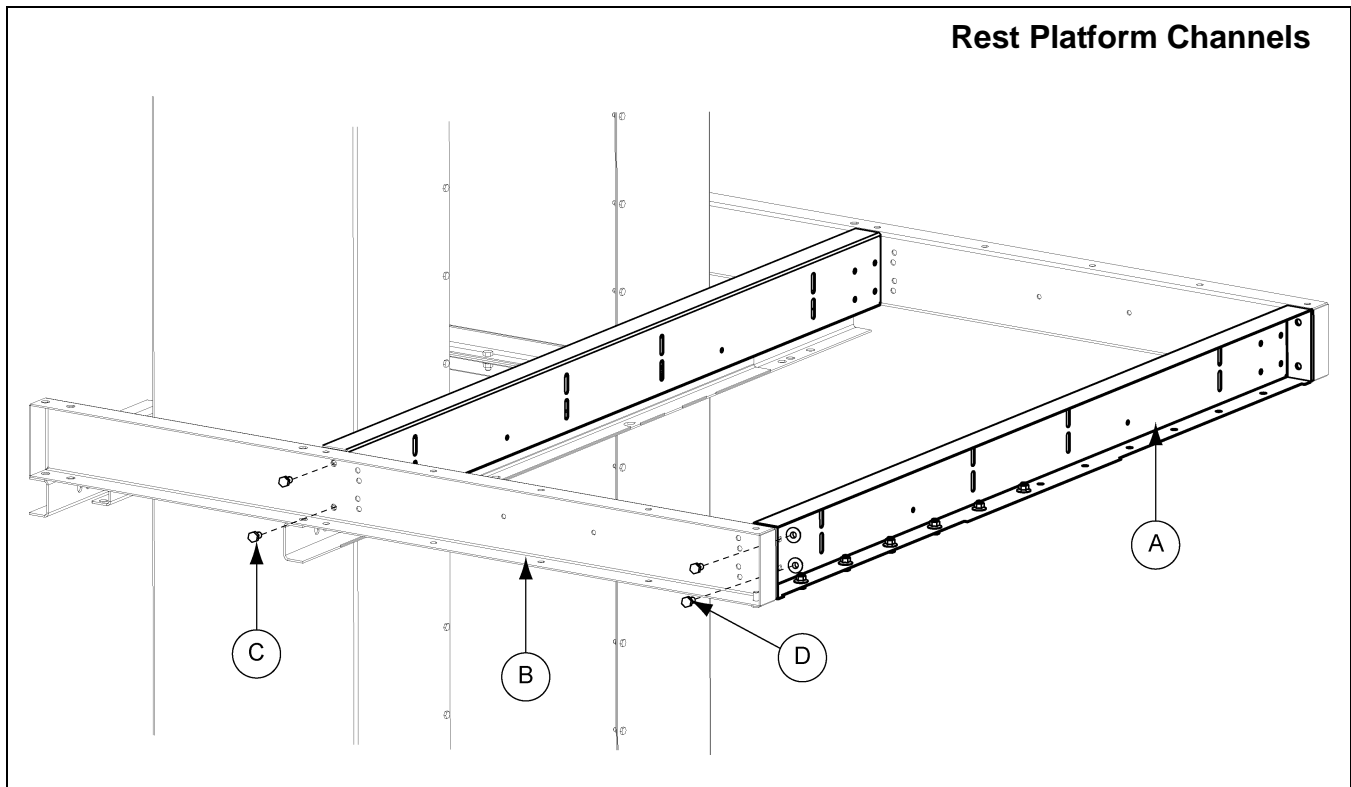

Figure 7G Rest Platform Cross Channel to Rest Platform Mounting Channels

Ref #	Part #	Description
A	RP1636CCX	Rest Platform Cross Channel
B	RP1636MCX	Rest Platform Mounting Channel
C	S-7105	3/8" x 3/4" Hex Bolt
D	S-968	3/8" Flange Nut

7. Rest Platform

Rest Platform Cross Channel to Rest Platform Mounting Channels (Continued)

2. Attach rest platform deck to the bottom of the rest platform mounting channels and rest platform cross channels, using 3/8" x 3/4" hex bolts. Bolt heads should be installed against the deck plate.
(See Figure 7H.) **NOTE:** The deck plate can be mounted on either the right or left side, but the flange must be mounted towards the opening.

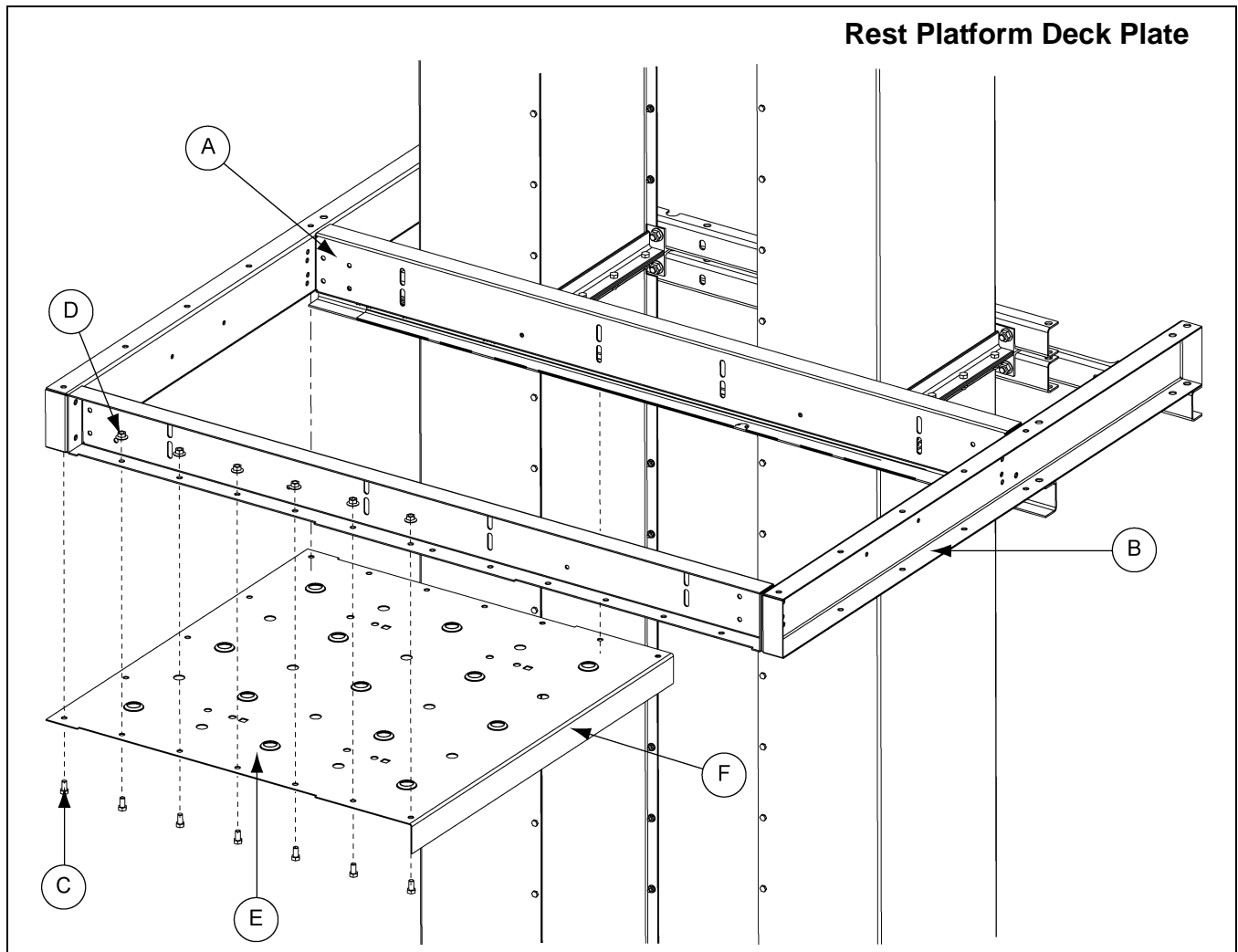

Figure 7H Deck Plate

Ref #	Part #	Description
A	RP1636CCX	Rest Platform Cross Channel
B	RP1636MCX	Rest Platform Mounting Channel
C	S-7105	3/8" x 3/4" Hex Bolt
D	S-968	3/8" Flange Nut
E	RP1636FDP	Rest Platform Flat Deck Plate
F		Deck Flange Towards Opening

Rest Platform Cross Channel to Rest Platform Mounting Channels (Continued)

3. Install the handrail platform posts to the rest platform mounting channels and rest platform channels using six (6) 5/16" x 3/4" flanged hex bolts for each post, four (4) bolt to the front and two (2) on the side. (See Figure 71.)

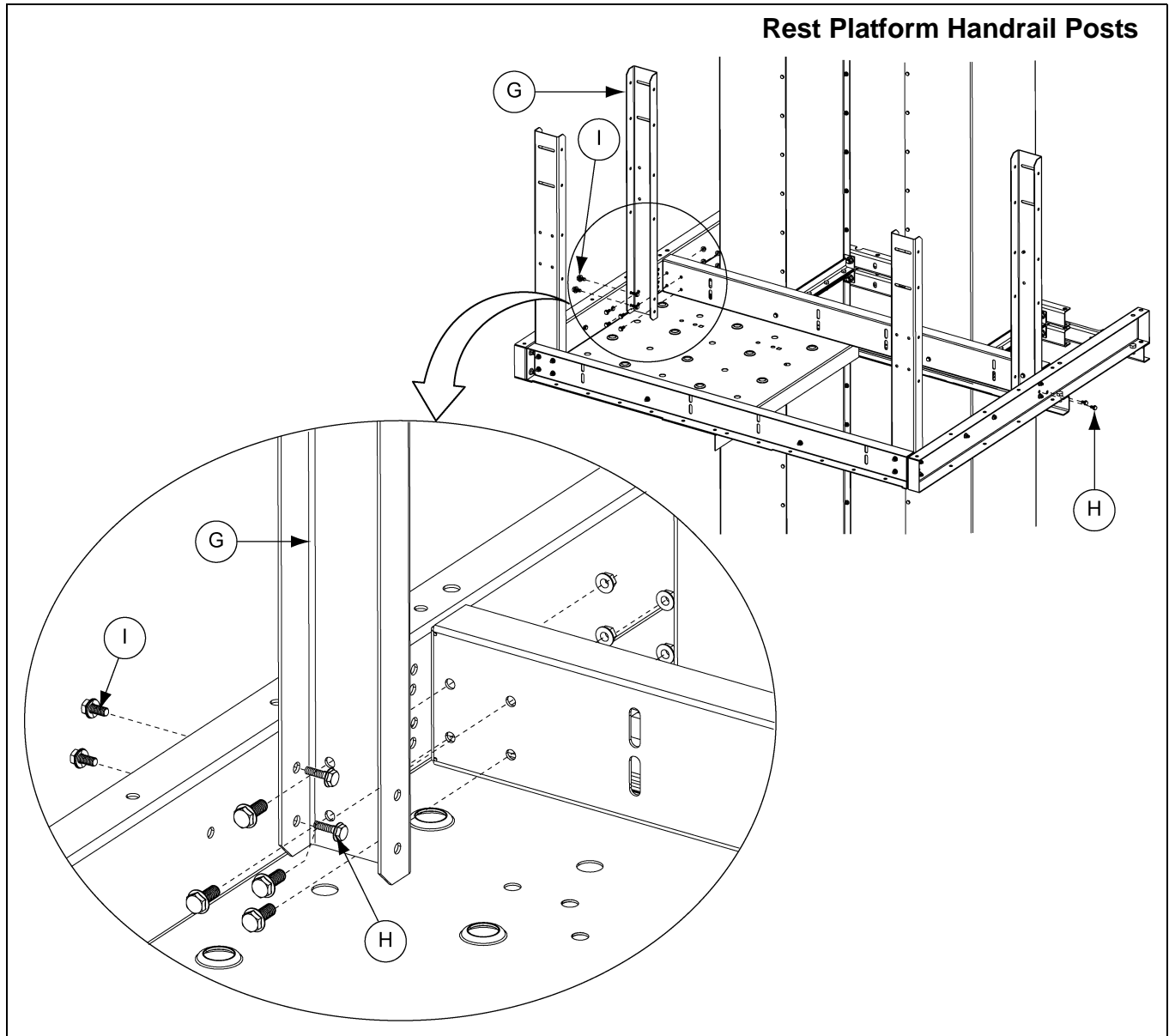

Figure 71

Ref #	Part #	Description
G	HP1648HCP	Handrail Platform Posts
H	S-6606	5/16" x 3/4" Flange Bolt
I	S-10268	5/16" Flange Nut

7. Rest Platform

Rest Platform Cross Channel to Rest Platform Mounting Channels (Continued)

4. Assemble the intermediate handrails by sliding the small handrail into the larger handrail to create a telescoping handrail that can be adjusted to the correct length between the posts. Two (2) of the small intermediate handrails and two (2) of the large intermediate handrails will need to be cut to fit. The starting length of each rail is 36". Cut 18" off the end of each rail so the final length of each rail is 18". (See [Figure 7J](#).)

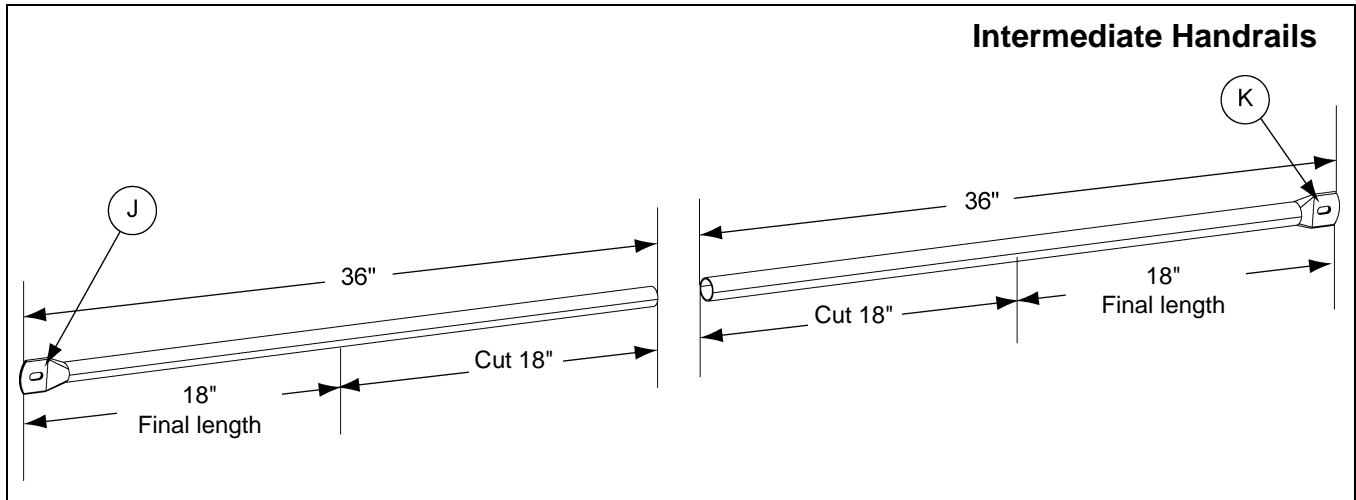

Figure 7J

Ref #	Description
J	Cut Two (2) Small Intermediate Rails
K	Cut Two (2) Large Intermediate Rails

Rest Platform Cross Channel to Rest Platform Mounting Channels (Continued)

5. Install the front and back intermediate handrails to the platform posts using 5/16" x 3/4" flanged hex bolts. Adjust the rail into position by sliding it out to the correct length.
6. After cutting the two (2) large and two (2) small intermediate handrails, slide them to the correct length and install them to the handrail posts on the short sides of the platform using 5/16" x 3/4" flanged hex bolts. (See Figure 7K.)

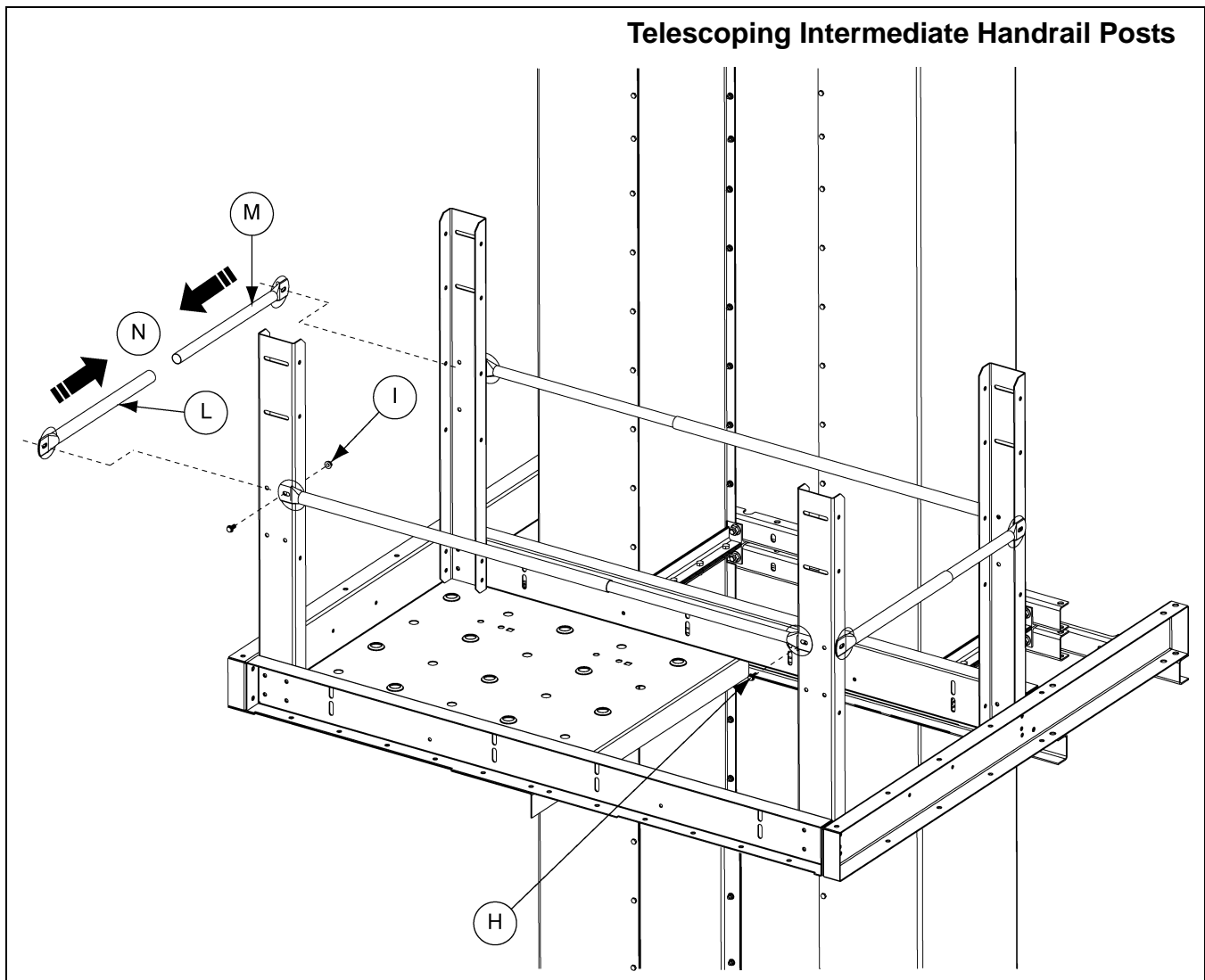

Figure 7K

Ref #	Part #	Description
H	S-6606	5/16" x 3/4" Flange Bolt
I	S-10268	5/16" Flange Nut
L	LDR-4087	Large Intermediate Handrail
M	LDR-4088	Small Intermediate Handrail
N		Slide Smaller Rail into Larger Rail

7. Rest Platform

Rest Platform Cross Channel to Rest Platform Mounting Channels (Continued)

7. Connect the front rest platform handrails and the side rest platform handrails to the handrail platform post using 5/16" x 2" hex bolts. (See Figure 7L.)

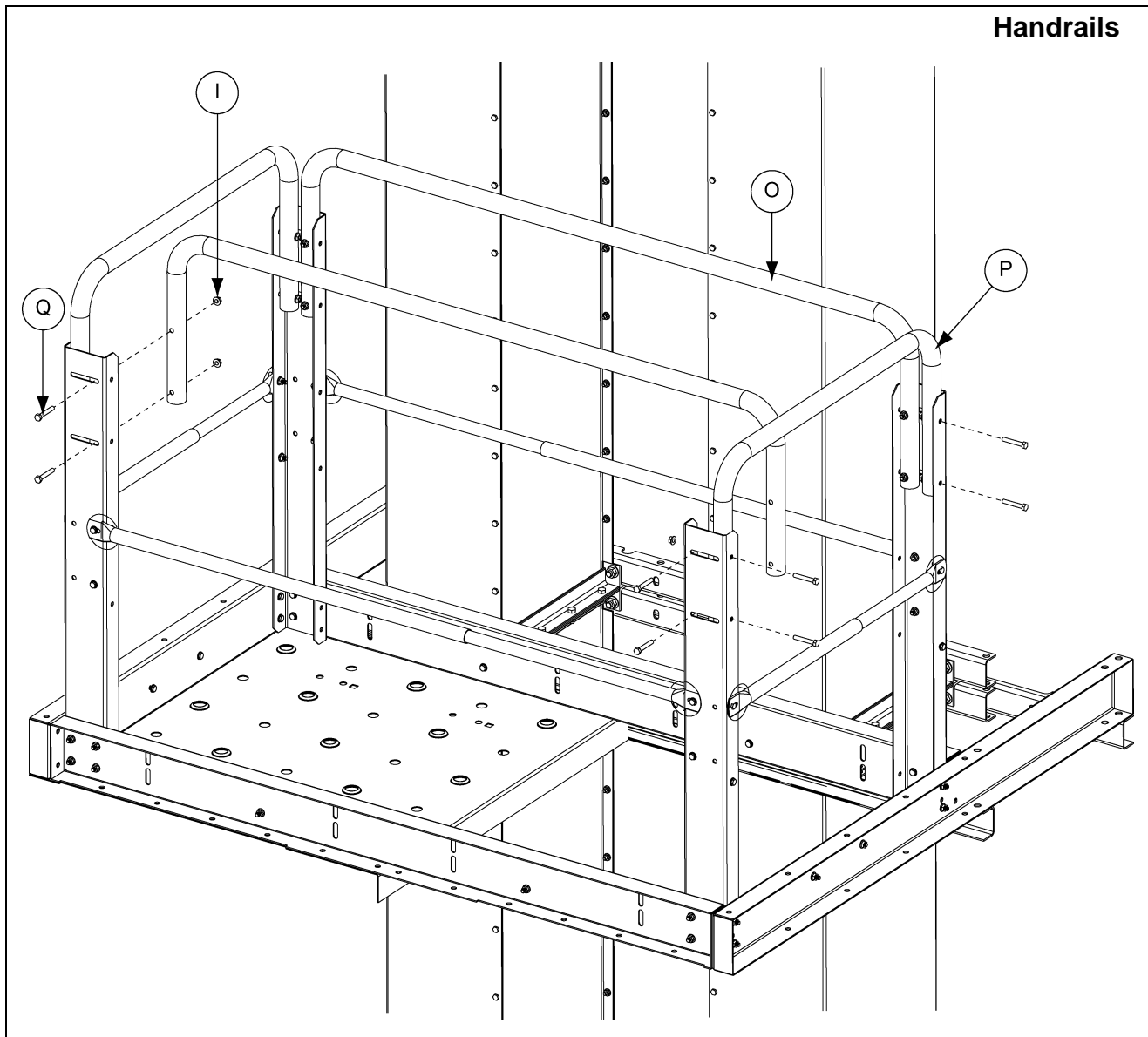

Figure 7L

Ref #	Part #	Description
I	S-10268	5/16" Flange Nut
O	RP1648HF	57-1/2" Handrail
P	RP1648HS	30.1" Handrail
Q	S-7877	5/16" x 2" Flange Bolt

Rest Platform Cross Channel to Rest Platform Mounting Channels (Continued)

8. Platform braces must be installed from handrail posts to mounting and cross channels using 5/16" x 3/4" flanged hex bolts. Braces should be attached to the outside of the platform post and to the inside of the mounting and cross channels. **NOTE:** Safety cage bars (LDR-517BE) are used as platform braces/tie angle braces through out this installation. Bolt heads should be on inside of platforms. (See Figure 7M.)

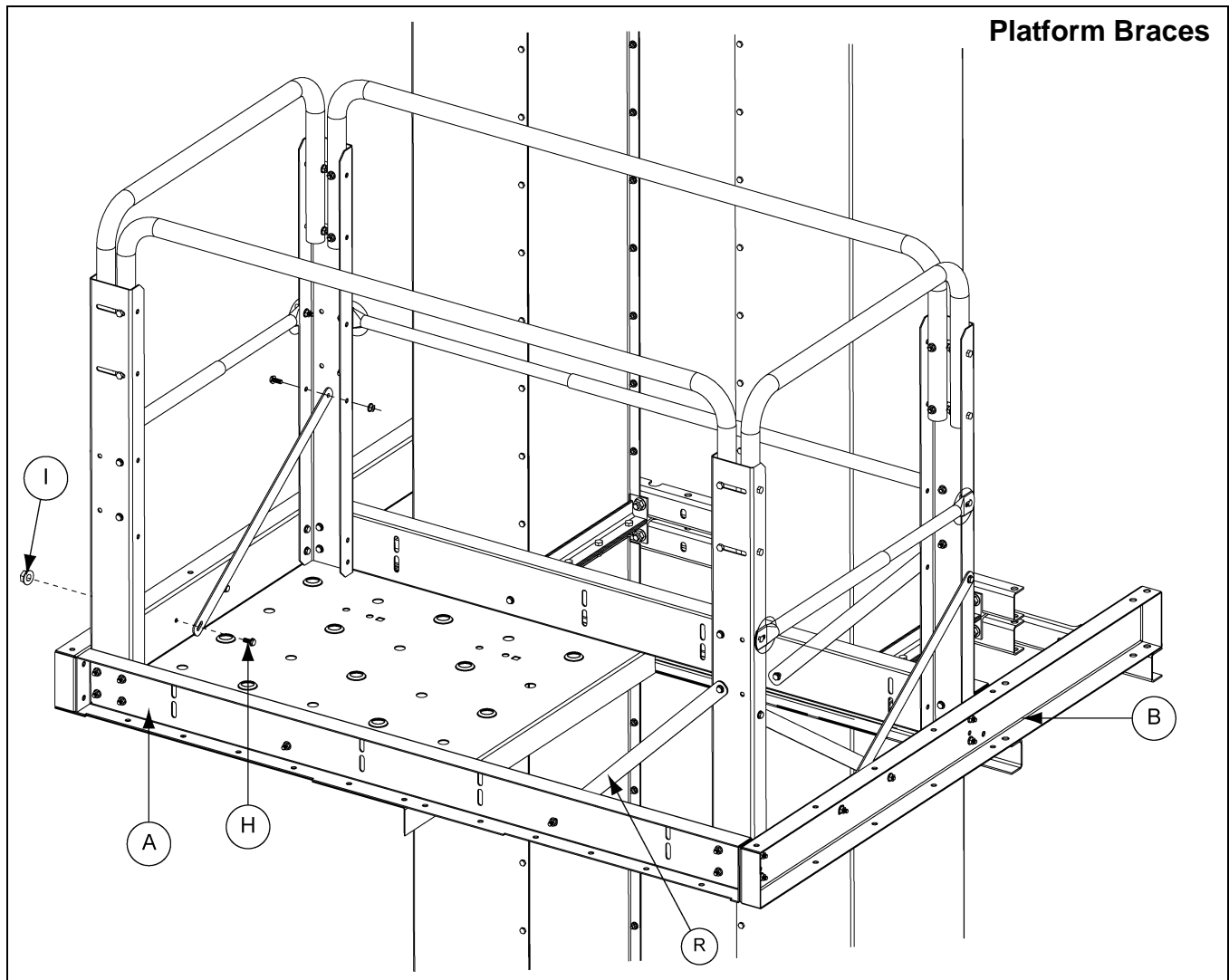

Figure 7M

Ref #	Part #	Description
A	RP1636CCX	Rest Platform Cross Channel
B	RP1636MCX	Rest Platform Mounting Channel
H	S-6606	5/16" x 3/4" Flange Bolt
I	S-10268	5/16" Flange Nut
R	LDR-5171BE	Brace

7. Rest Platform

Rest Platform Cross Channel to Rest Platform Mounting Channels (Continued)

9. Install ladder support brackets to the rest platform cross channel using 3/8" x 3/4" hex bolts.
10. Attach ladders to ladder support brackets using 1/2" x 3/4" hex bolts. (See Figure 7N.)

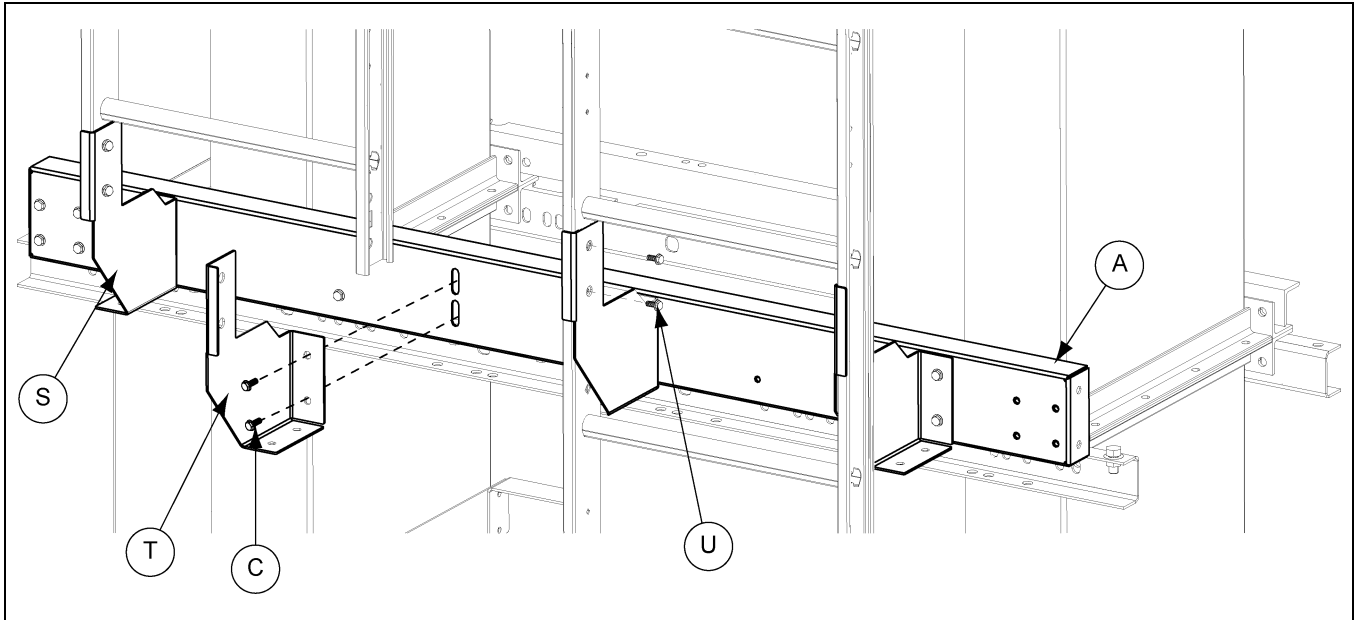

Figure 7N

Ref #	Part #	Description
A	RP1636CCX	Rest Platform Cross Channel
C	S-7105	3/8" x 3/4" Hex Bolt
S	LAD1648BLH	Ladder Support L.H. Bracket
T	LAD1648BRH	Ladder Support R.H. Bracket
U	S-7932	1/2" x 3/4" Hex Bolt

Ladder Support

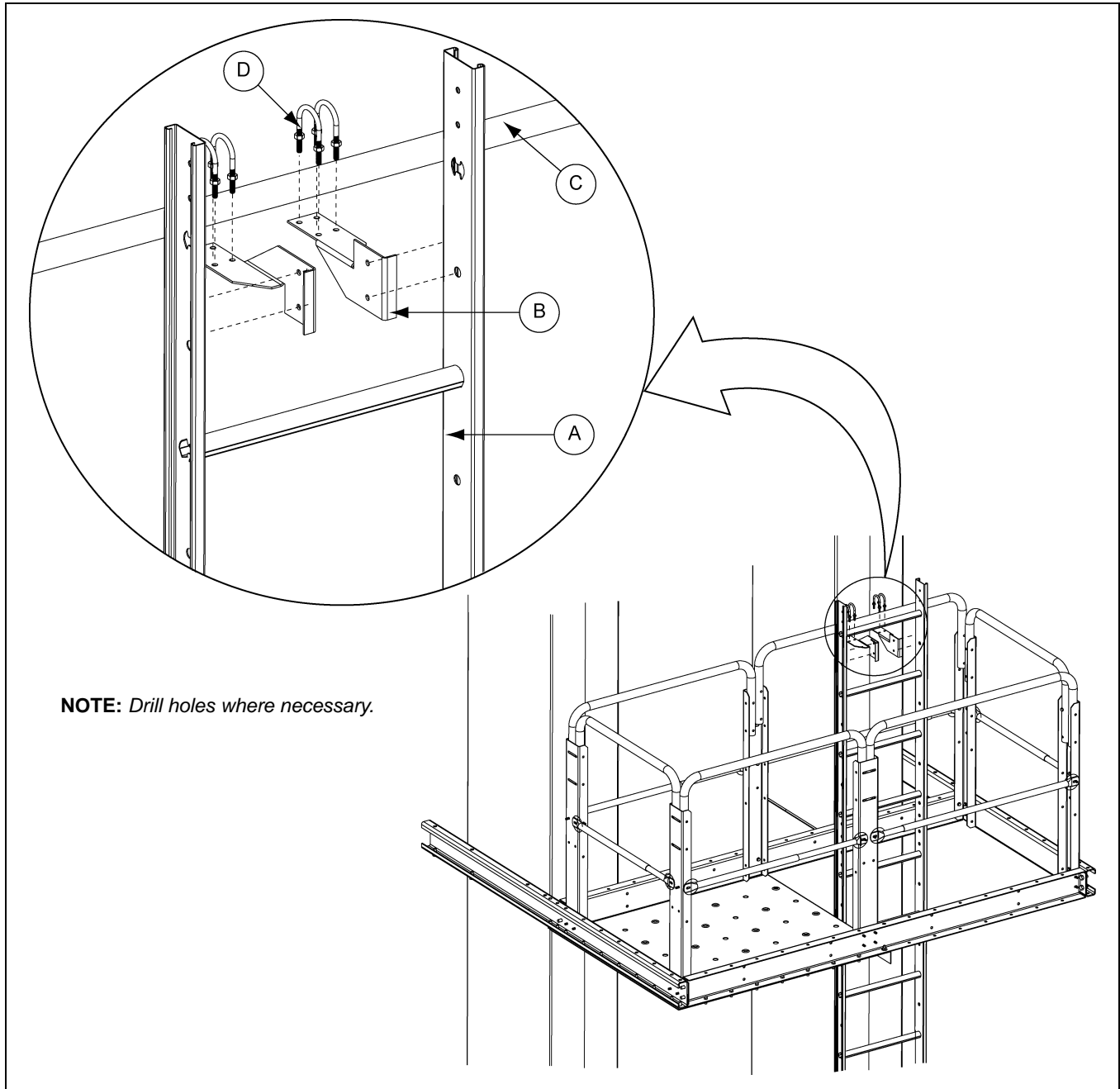

Figure 70

Ref #	Part #	Description
A	14FOOTRFWX or 14FOOTX	14' Ladder Section
B	RP1648LS	Ladder Support Rest Platform
C	RP1648HSX	48" HSP Sides 43.605" Outside Handrail
D	S-10136	U-Bolt 1/4"-20 x 1-1/2"

Chapter 8: 16"-24" Head Platform Assembly

Considerable time is dedicated at the beginning of this manual to the proper orientation of channels and decks. This is because the orientation of these elements is essential to the proper construction of the head platform.

1. There are many ways to get the orientation wrong and only one way to get it right.
2. Proper orientation of the channels and decks is essential proper assembly.
3. Proper construction of the head platform can only be completed if the initial orientation of the channels is done correctly.

Please take time to confirm that the orientation of these early elements is correct before you begin to assemble the decking on to the channels.

Attach Main Support Channels to Lower Head

1. Place lower head section on solid and level surface.
2. At **both the Discharge End and Up-Leg End**, orient the channels so that lip/channel openings face outward, away from the lower head.
3. Attach each **Main Support Channel** to the **Lower Head Bracket** at the top most set of holes using 3/8" x 1" bolts and nuts and torque to standard specifications. (See Figure 8A.)

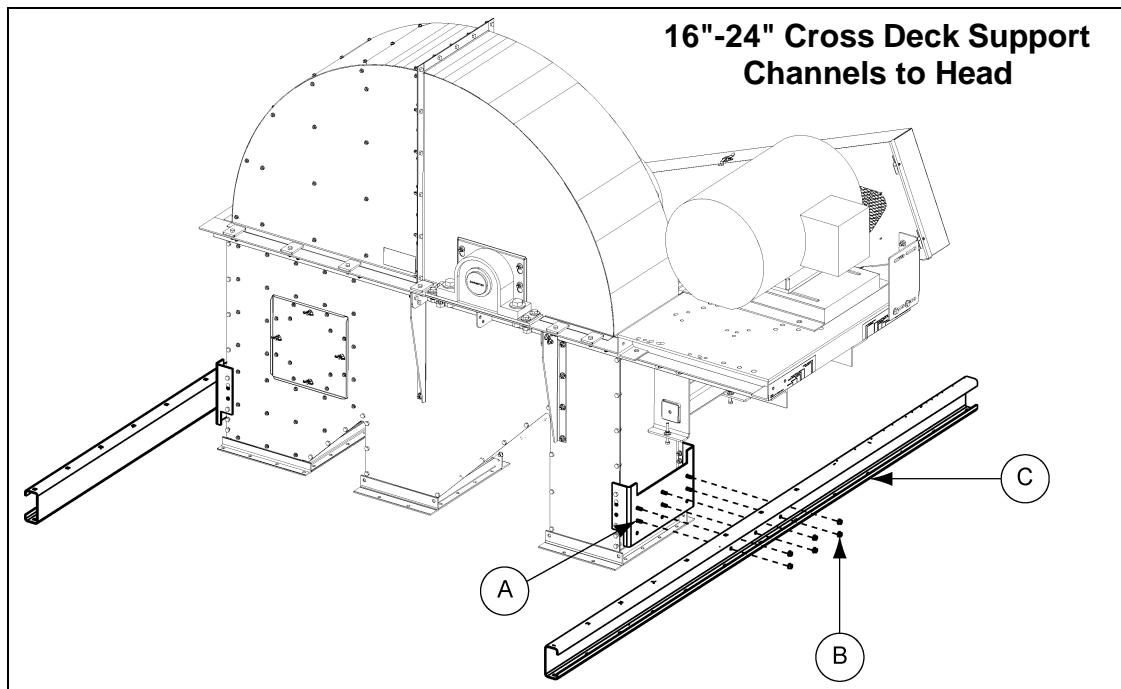

Figure 8A Cross Deck Support Channels Head

Ref #	Part #	Description
A	S-7469	3/8" x 1" Bolt
B	S-10028	3/8" Flange Nut
C	HSP16001X	16"-24" Main Support Channel

Install Deck A and Toe Board

1. Orient the lip of the side toe board (HP1624STBX) out/away from the lower head and slide into place on non-drive side. Toe board hole **A1** should be at the discharge end and **A3** is at the up-leg end.
2. Locate pre-assembled Deck A, which consists of the hatch opening and connecting flanges.
3. Using a punch as needed for alignment, connect Deck A to the side toe board with 3/8" flange nuts (S-10028) and 3/8" x 3/4" flange bolts (S-7105). Torque to standard specifications. (See Figure 8B.)
 - a. Deck hole **A1** to toe board hole **A1**.
 - b. Deck hole **A2** to toe board hole **A2**.
 - c. Deck hole **A3** to toe board hole **A3**.

NOTE: Due to snug fit, slide side toe board in place before securing Deck A or any subsequent decking.

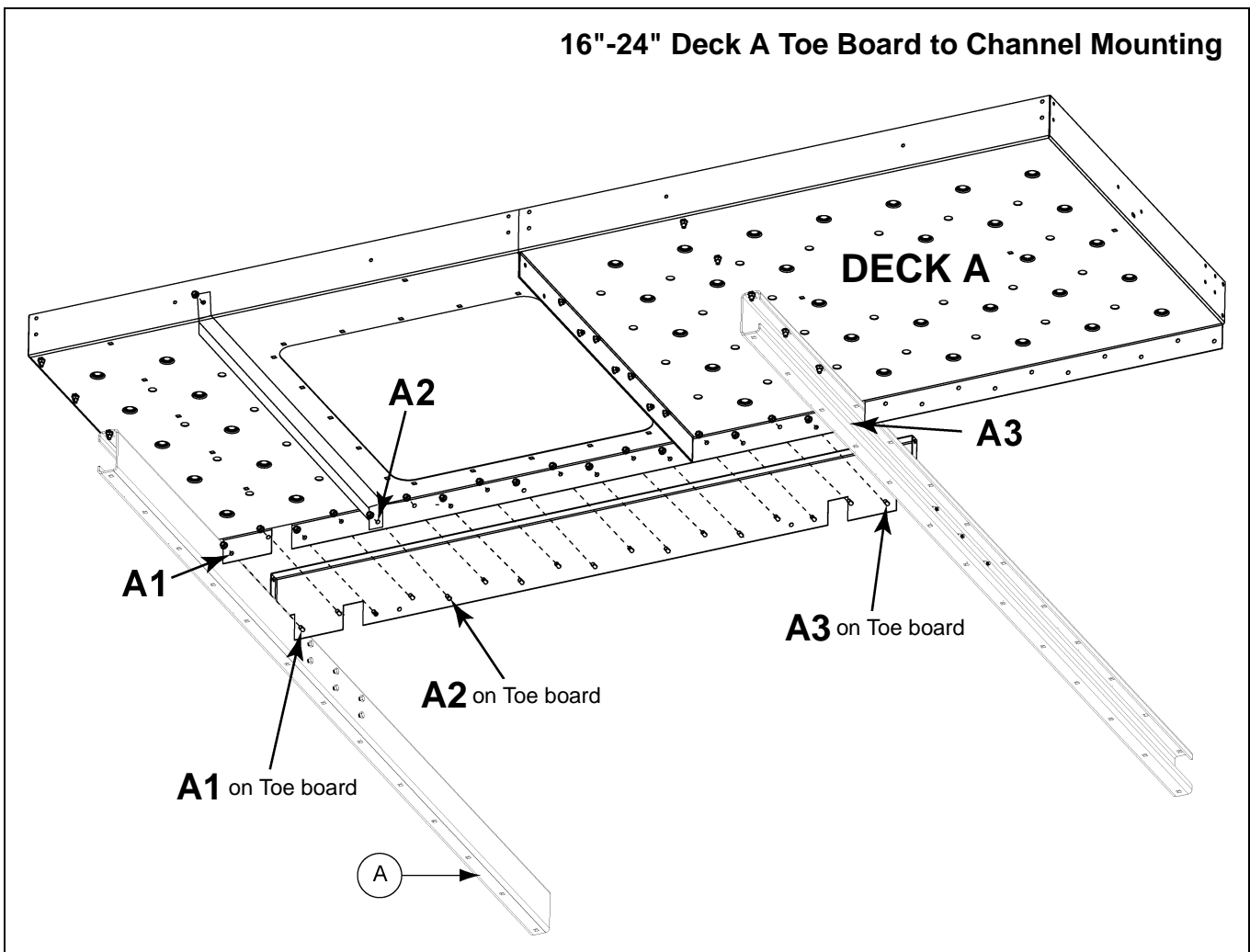

Figure 8B Deck A Toe Board Channel Location

Ref #	Description
A	NOTE: 24" Position shown. Only difference between 16" and 24" is location of discharge channel.

8. 16"-24" Head Platform Assembly

Install Deck A to Main Support Channels

1. Using 3/8" x 1" carriage bolts (S-3585) and 3/8" flange nuts (S-10028), connect Deck A to main support channel. **IMPORTANT:** Connect every hole. (See Figure 8C.)

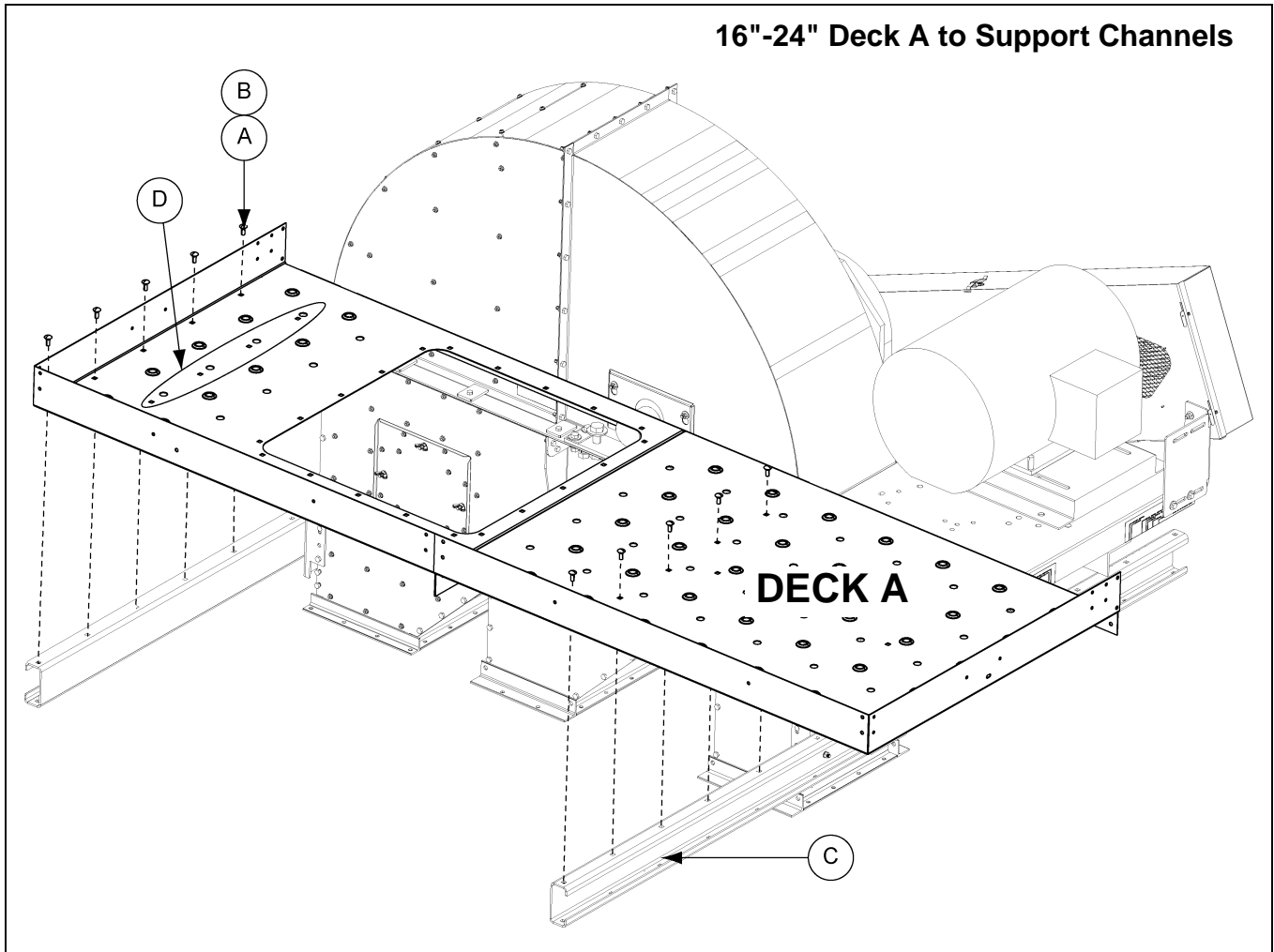

Figure 8C Deck A to Support Channels

Ref #	Part #	Description
A	S-3585	3/8" x 1" Carriage Bolt
B	S-10028	3/8" Flange Nut
C	HSP16001X	Main Support Channel
D		NOTE: 16" will use this row of holes.

Install Deck A to Main Support Channels (Continued)

2. Install decking support (HP1624DS) to up-leg end of Deck A as shown, using 3/8" x 1" bolts (S-7105) and 3/8" nuts (S-10028).
3. Install the hatch deck support bar (HP1624HDSX) to Deck A. This piece installs on the underside of Deck A and extends the width of the deck from edge to edge.

Using 3/8" flange nuts (S-10028) and 3/8" x 3/4" flange bolts (S-7105), connect the hatch deck support bar to Deck A kick plate and through the holes labeled **A2** on Deck A and side toe board. Torque to standard specifications. (See Figure 8D.)

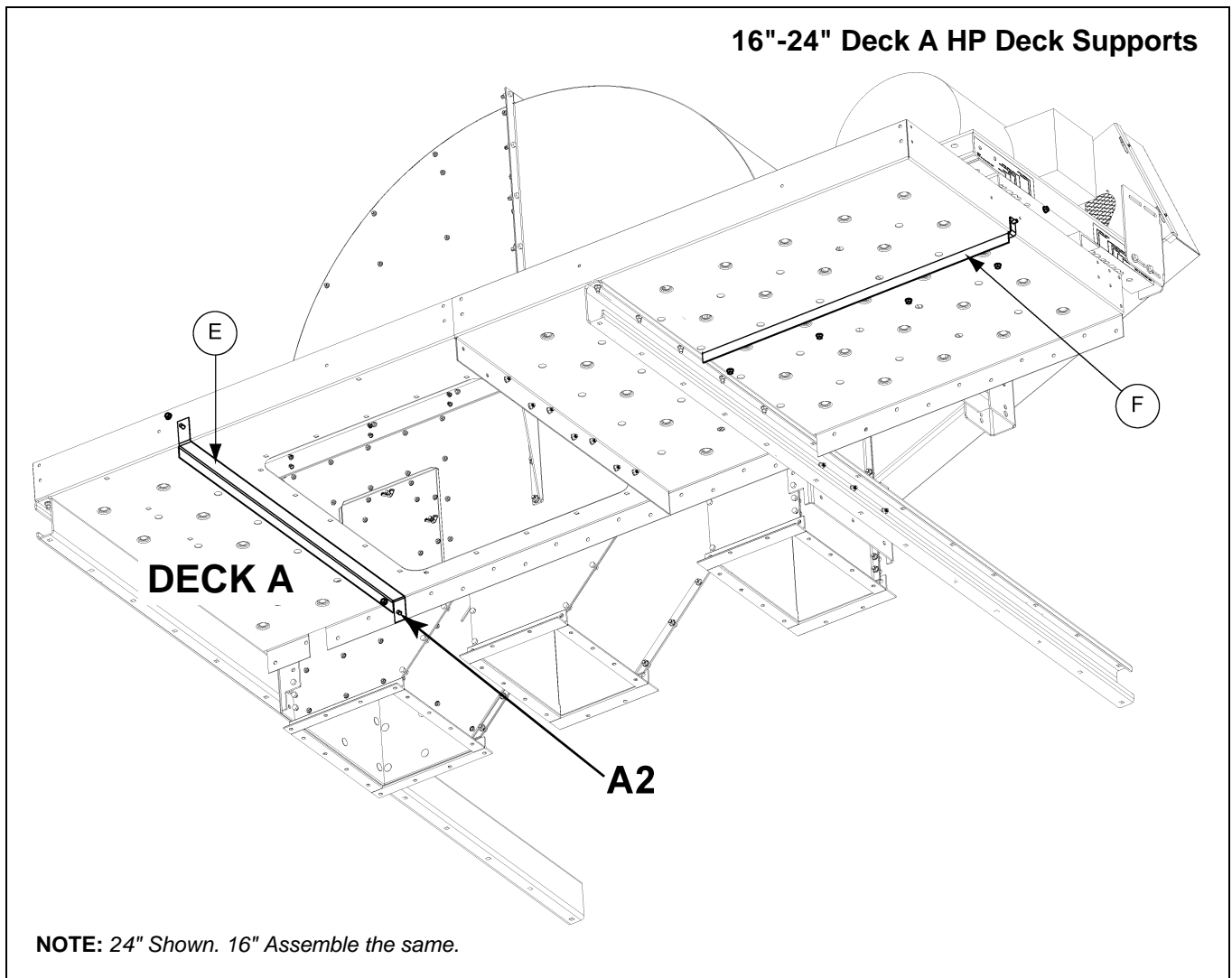

Figure 8D Deck A HP Deck Supports

Ref #	Part #	Description
E	HP1624HDSX	Hatch Deck Support Bar
F	HP1624DS	Decking Support

8. 16"-24" Head Platform Assembly

Install Deck C and Toe Board

1. Locate pre-assembled Deck C, consisting of two (2) planks and connecting tabs.
2. Slide side toe board into place on the drive side of the lower head.
3. Orient the side toe board so that the hole labeled **A1** is at the up-leg end and **A3** is at the discharge end of the lower head.
4. Using a punch as needed for alignment, connect Deck C to side toe board using 3/8" x 1" carriage bolts (S-3585) with flange nuts (S-10028) and torque to standard specifications. *(See Figure 8E.)*
 - a. Deck hole **C1** to toe board hole **A3**.
 - b. Deck hole **C2** to toe board hole **A4**.
 - c. Deck hole **C3** to toe board hole **A1**.

NOTE: Due to snug fit, slide side toe board in place before securing Deck C or any subsequent decking.

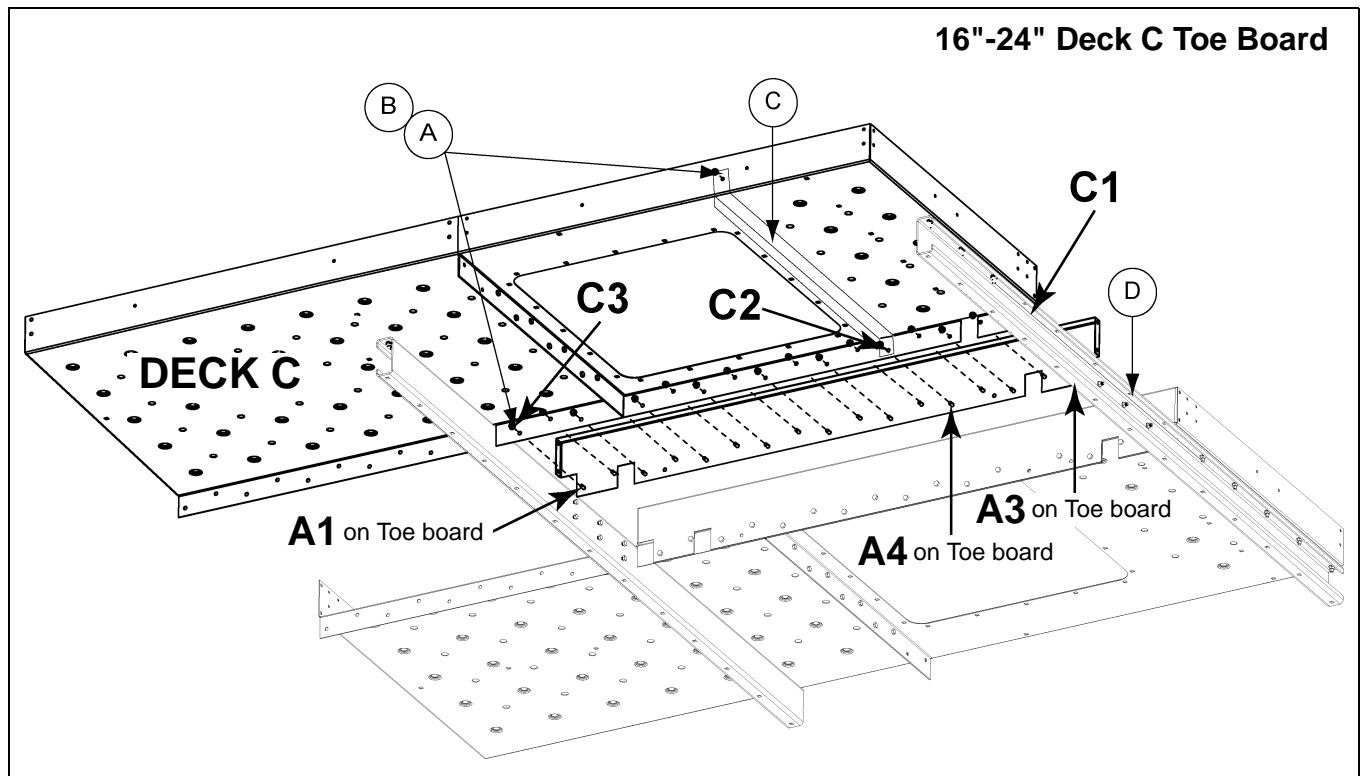

Figure 8E 24" Deck C Toe Board

Ref #	Part #	Description
A	S-7105	3/8" x 3/4" Flange Bolt
B	S-10028	3/8" Flange Nut
C	HP1624HDSX	Hatch Deck Support Bar
D		NOTE: 24" Position shown. Only difference between 16" and 24" is location of discharge channel location.

Install Deck C to Main Support Channels

1. Using 3/8" x 1" carriage bolts (S-3585) and 3/8" flange nuts (S-10028), connect Deck C to main support channel. **IMPORTANT:** Connect every hole. (See Figure 8F.)
2. Install decking support (HP1624DS) to up-leg end of Deck A as shown. Using five (5) 3/8" x 1" bolts (S-7105) and 3/8" nuts (S-10028).
3. Install the hatch deck support bar (HP1624HDSX) to Deck C. This piece installs on the underside of Deck C and extends the width of the deck from edge to edge.
 - a. Using 3/8" flange nuts (S-10028) and 3/8" x 3/4" flange bolts (S-7105), connect the hatch deck support bar to the kick plate attached to Deck C and to the hole labeled **A2** on decking nearest the side toe board and lower head. Torque to standard specifications. (See Figure 8G.)

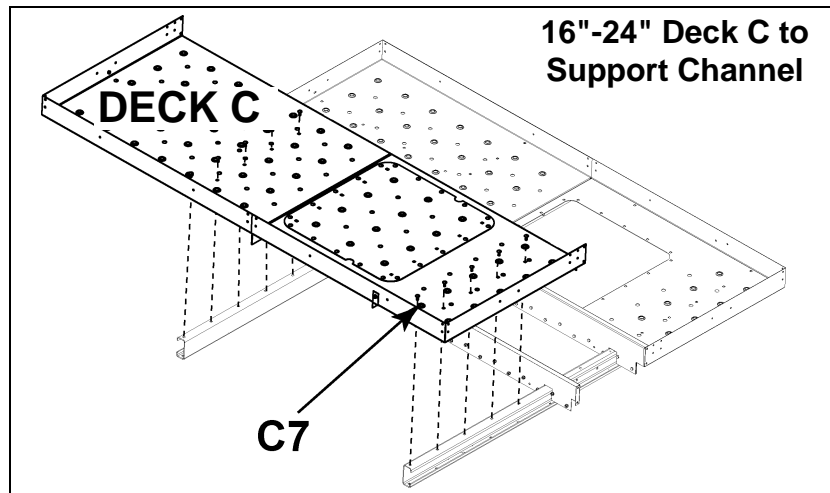

Figure 8F 16" Deck C to Support Channels

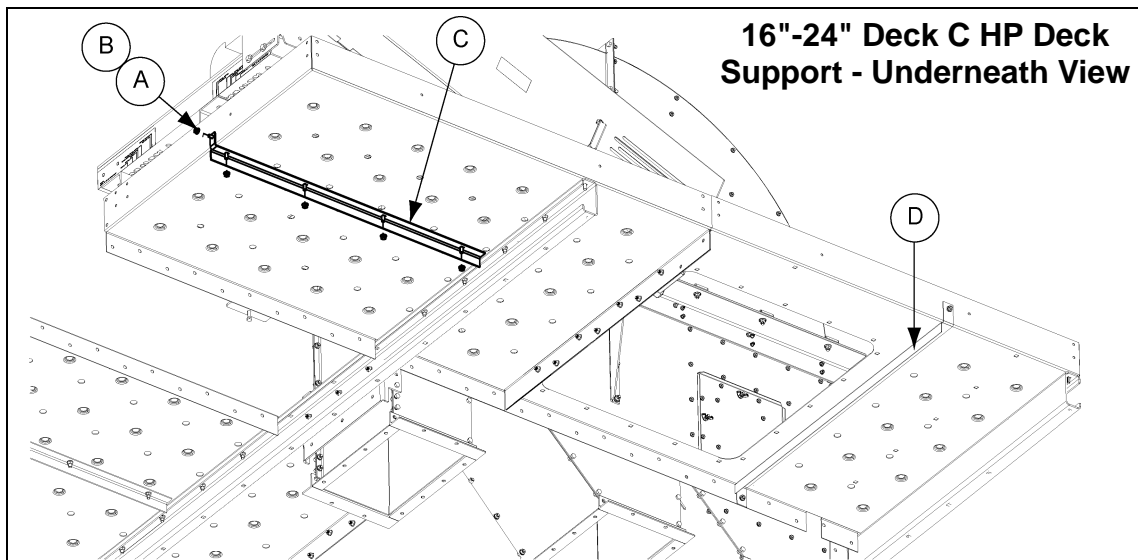

Figure 8G Deck C HP Deck Support as Viewed from Underneath.

Ref #	Part #	Description
A	S-3585	3/8" x 1" Carriage Bolt
B	S-10028	3/8" Flange Nut

Ref #	Part #	Description
C	HP1624DS	HP1624 Decking Support
D	HP1624HDSX	Hatch Deck Support Bar

8. 16"-24" Head Platform Assembly

Install Deck E

NOTE: The orientation of the flanges on Deck E is important to proper assembly. Deck E flanges should be to the outside of Deck A and Deck C.

1. Locate Deck E. It is the smallest deck.

NOTE: Deck E will attach to Deck A, Deck C, both side toe boards and the main support channel.

2. Using a punch as needed for alignment, connect Deck E to the side toe board using 3/8" x 1" carriage bolts (S-3585) with flange nuts (S-10028). Torque to standard specifications. (See Figure 8H.)
 - a. Deck E hole **E1** to Deck A hole **A5**.
 - b. Deck E hole **E2** to Deck A hole **A4**.
 - c. Deck E hole **E3** to Deck C hole **C5**.
 - d. Deck E hole **E4** to Deck C hole **C4**.

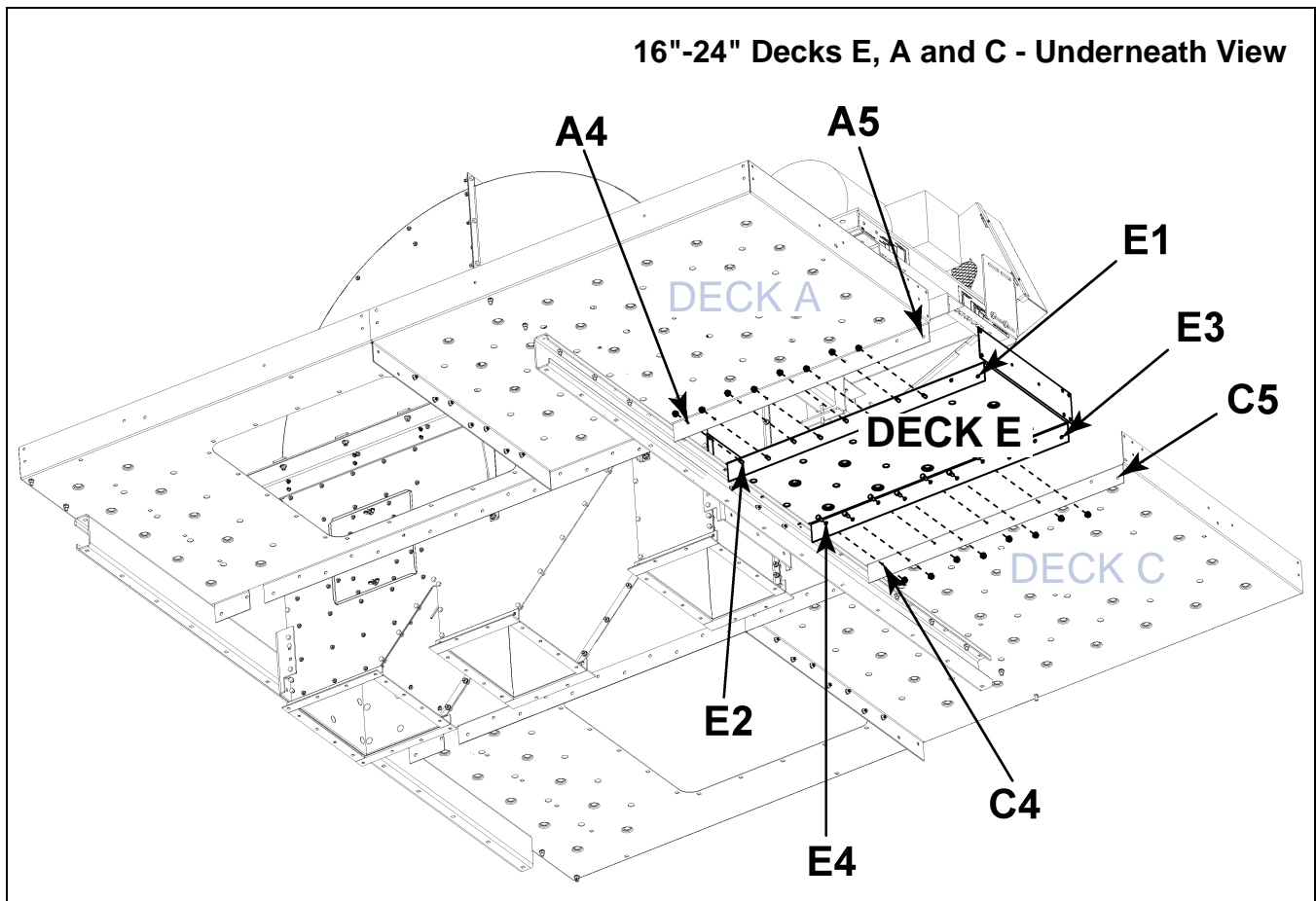

Figure 8H Deck E, Deck A and Deck C as Viewed from Underneath.

Install Deck E (Continued)

3. Using 3/8" x 1" carriage bolts (S-3585) and 3/8" flange nuts (S-10028), connect Deck E to main support channel. **IMPORTANT:** Connect every hole. (See Figure 8I.)
4. Align Deck E so the flanges are to the outside of Deck A and Deck C. Using 3/8" x 1" bolts (S-7105) and 3/8" flange nuts (S-10028), connect Deck E to toe boards and flanges of Deck A and Deck C. (See Figure 8J.)

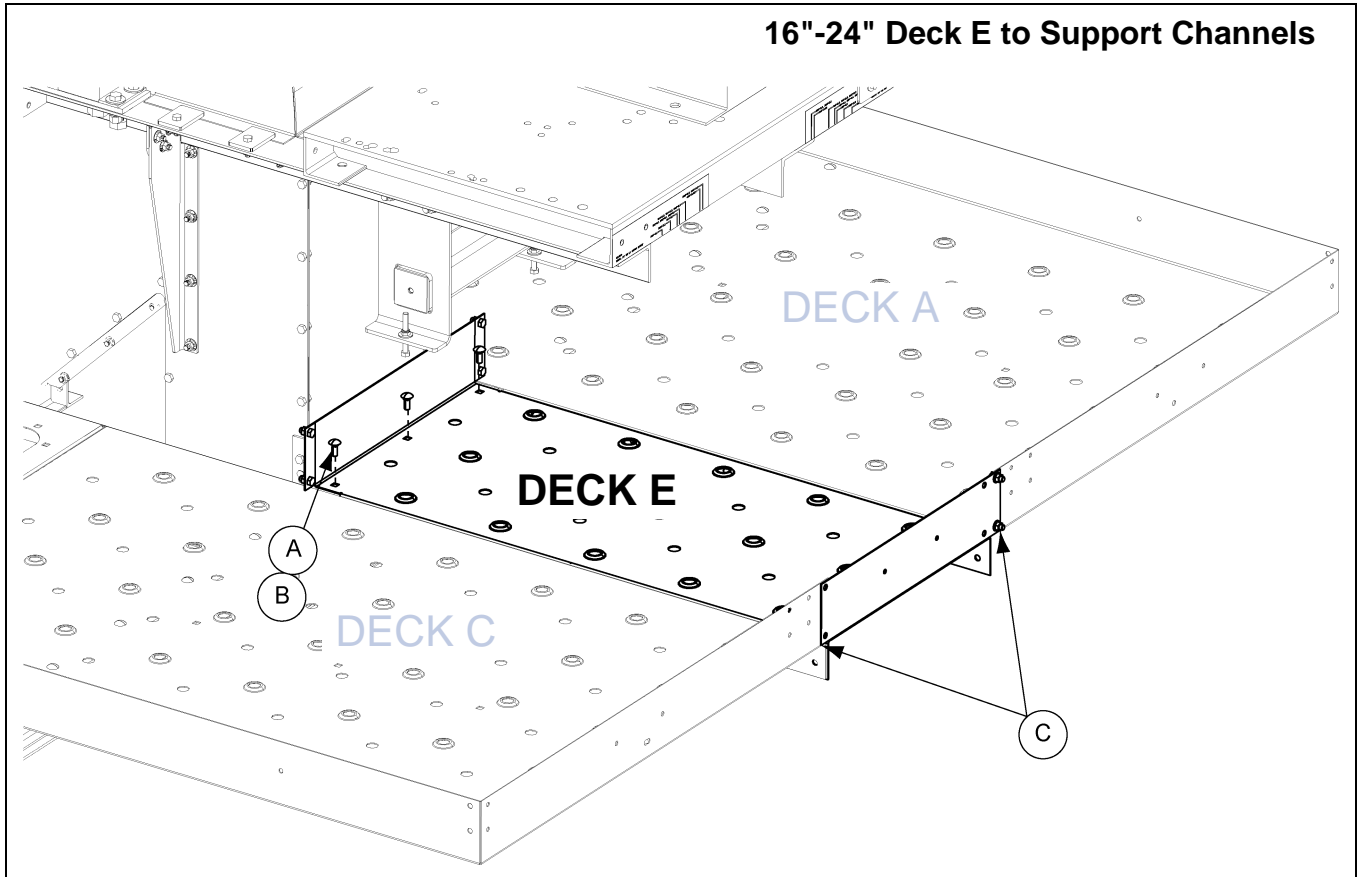

Figure 8I 24" Deck E to Support Channels

Ref #	Part #	Description
A	S-3585	3/8" x 1" Carriage Bolt
B	S-10028	3/8" Flange Nut
C		Deck E Flanges Outside Deck A and Deck C

Install Deck E (Continued)

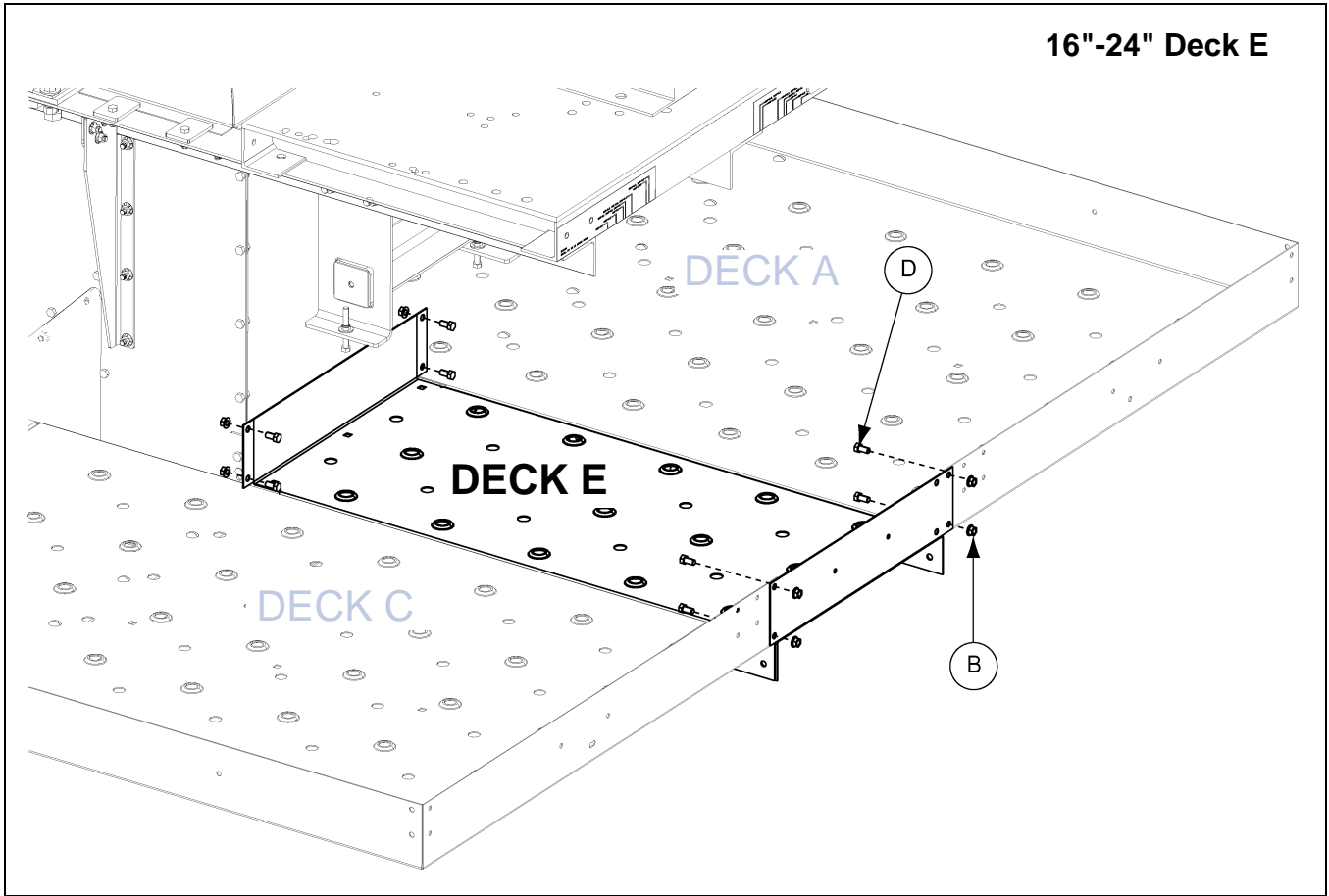

Figure 8J 24" Deck E

Ref #	Part #	Description
B	S-10028	3/8" Flange Nut
D	S-7105	3/8" x 1" Bolt

Install Adapter Bracket for 16" Platforms

NOTE: The adapter bracket attaches to decking and toe boards. The flanges should be to the outside of Deck A and Deck C.

- Using three (3) 3/8" x 1" carriage bolts (S-3585) and 3/8" flange nuts (S-10028), install the adapter bracket to cross deck support channel at the up-leg end of the platform between Deck A and side toe board and between Deck C and side toe boards. (See Figure 8K.)
- Attach deck adapter bracket (HP1624AB) to Deck A, Deck C and toe boards using four (4) 3/8" x 1" bolts (S-7105) and nuts. (See Figure 8L.)

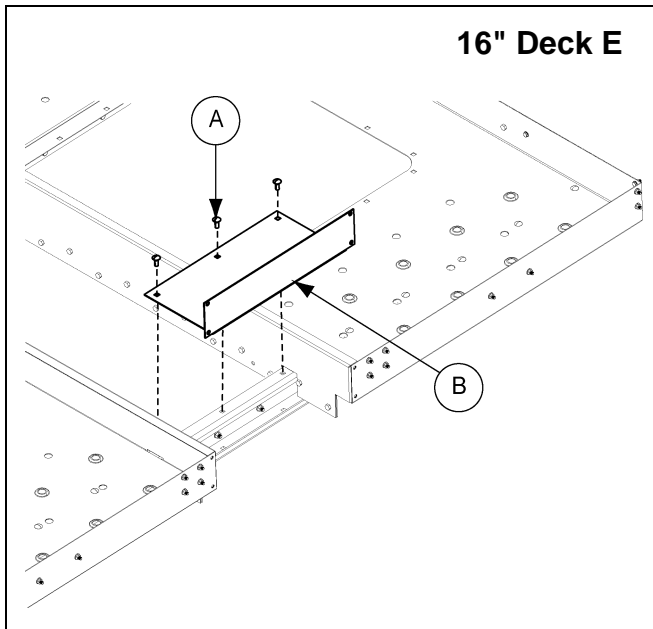

Figure 8K Deck Adapter Bracket to Channel

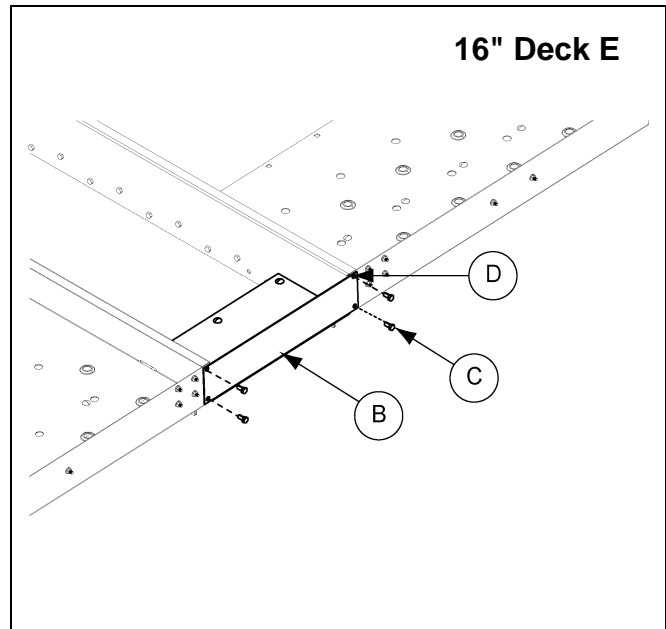

Figure 8L Deck Adapter Bracket to Decks

Ref #	Part #	Description
A	S-3585	3/8" x 1" Carriage Bolt
B	HP1624AB	16" HP Adapter Bracket

Ref #	Part #	Description
B	HP1624AB	16" HP Adapter Bracket
C	S-7105	3/8" x 1" Bolt
D	S-10028	3/8" Flange Nut

8. 16"-24" Head Platform Assembly

Install Hatch Filler Plate

1. Using 3/8" x 1" carriage bolts (S-3585) and 3/8" flange nuts (S-10028), install the hatch filler plate (HP1624HDF) over the un-used opening. (See Figure 8M.)

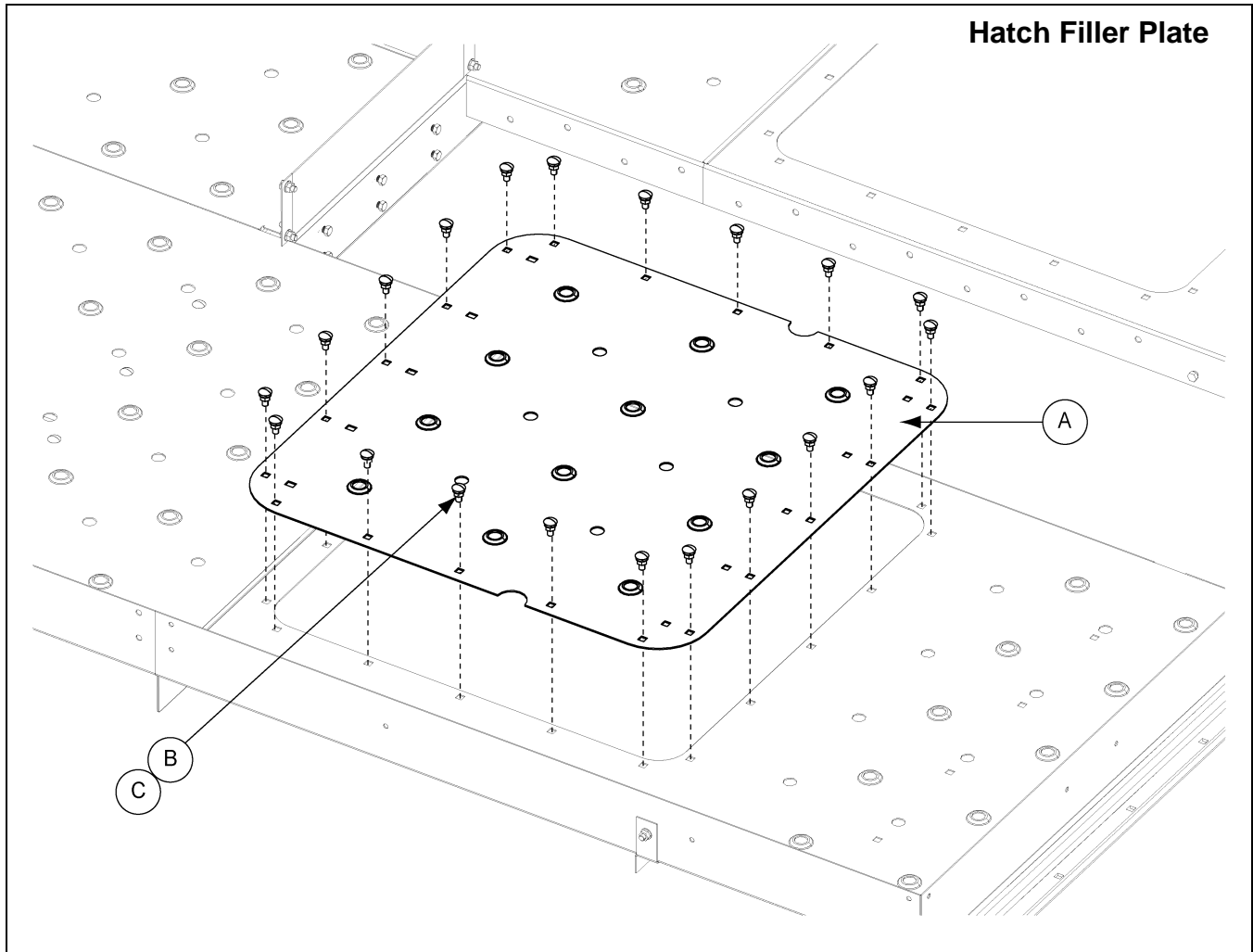

Figure 8M Deck Plate

Ref #	Part #	Description
A	HP1624HDF	Hatch Deck Filler Plate
B	S-3585	3/8" x 1" Carriage Bolt
C	S-10028	3/8" Flange Nut

Install Rail Supports to Deck E

1. Attach two (2) head platform rail supports (HP1648HSH) to Deck E as shown using 3/8" x 1" bolts (S-7105) and 3/8" flange nuts (S-10028). (See Figure 8N.)

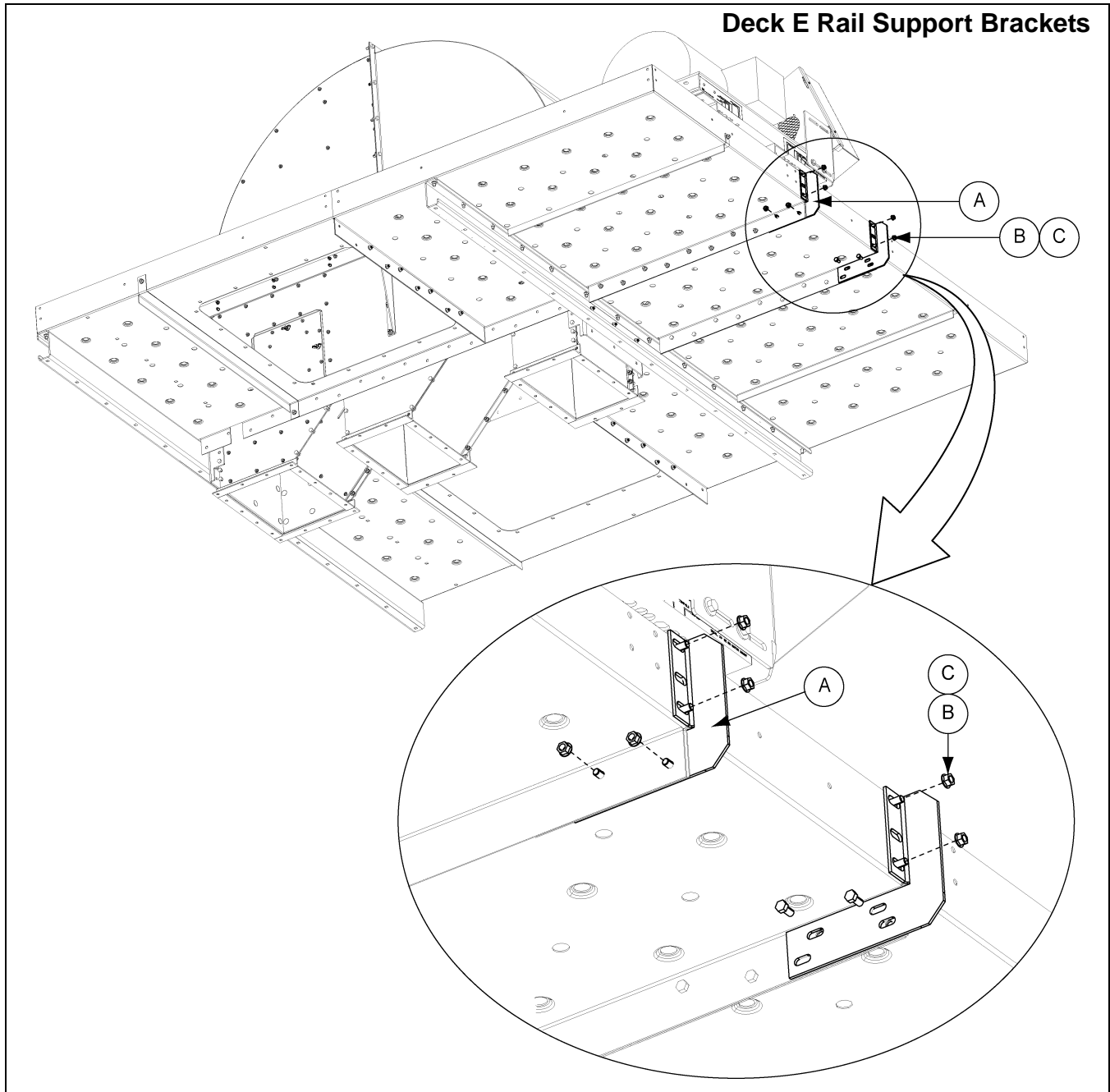

Figure 8N 24" Deck E Rail Support Brackets

Ref #	Part #	Description
A	HP1648HSH	Head Platform Rail Support
B	S-7105	3/8" x 1" Bolt
C	S-10028	3/8" Flange Nut

8. 16"-24" Head Platform Assembly

Install "W" Posts ("Corner Posts" x 4)

1. At each corner, align bottom edges of "W" corner posts (HP1648HWP) with bottom edge of platform decking.
2. Attach each "W" corner post to decking using 5/16" x 3/4" flange bolts (S-6606) and 5/16" flange nuts (S-10268). Torque to standard specifications. (See Figure 80.)

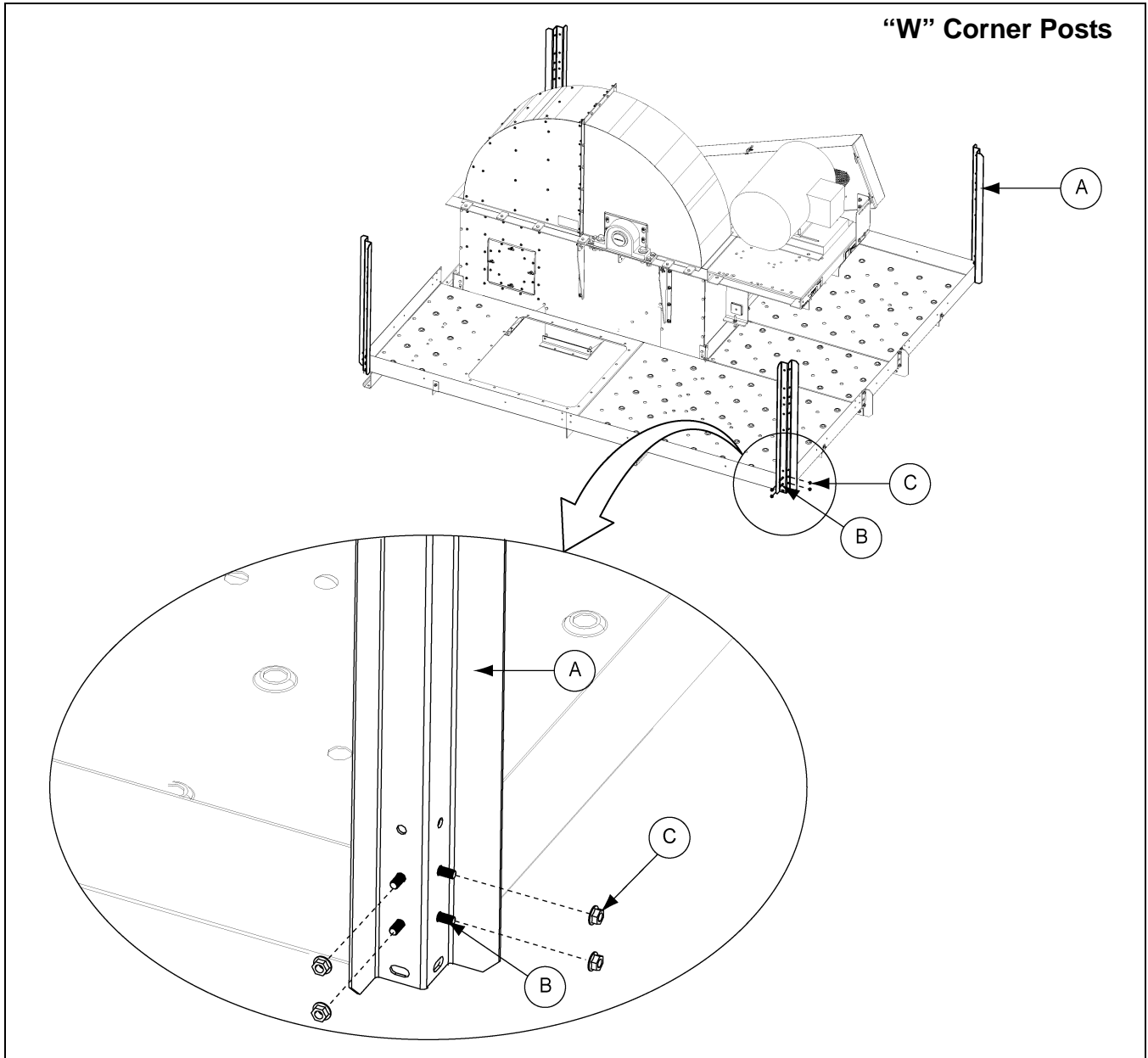

Figure 80

Ref #	Part #	Description
A	HP1648HWP	Head/Distributor "W" Corner Post
B	S-6606	5/16" x 3/4" Flange Bolt
C	S-10268	5/16" Flange Nut

Install Platform Posts

NOTE: Platform posts are not flush with bottom of deck.

1. At the up-leg end, align two (2) platform posts (HP1648HCP) as described and connect to the decking where Deck E intersects with Decks A and C. Use 5/16" hex flange nuts (S-10268) and 5/16" x 3/4" flange bolts, connect the platform posts to the decking.

NOTE: Rail support braces should be between the posts.

2. At the discharge end, align platform posts as described and attach one platform posts (HP1648HCP) to the edge of Deck C and Deck A nearest the lower head. (See Figure 8P.)

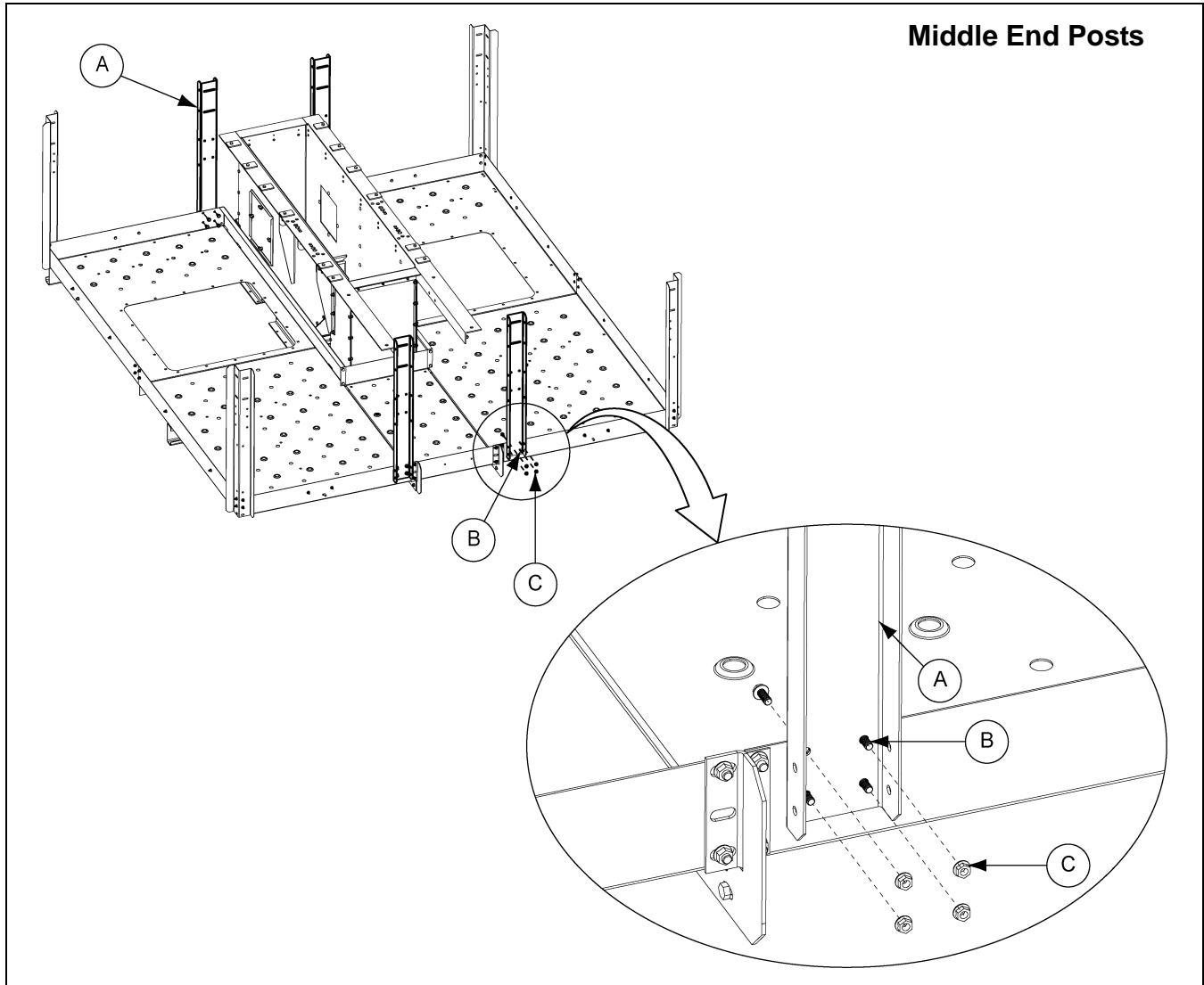

Figure 8P Middle End Posts

Ref #	Part #	Description
A	HP1648HCP	Platform Post
B	S-6606	5/16" x 3/4" Flange Bolt
C	S-10268	5/16" Flange Nut

8. 16"-24" Head Platform Assembly

Install Platform Posts (Continued)

3. At the middle of Deck A and Deck C, install platform post (HP1648HCP) as shown and connect to the decking *through* a rail support (HP1648HSH). Use 5/16" hex flange nuts (S-10268) and 5/16" x 3/4" flange bolts to connect the rail supports and platform posts to the decking.

(See Figure 8Q.)

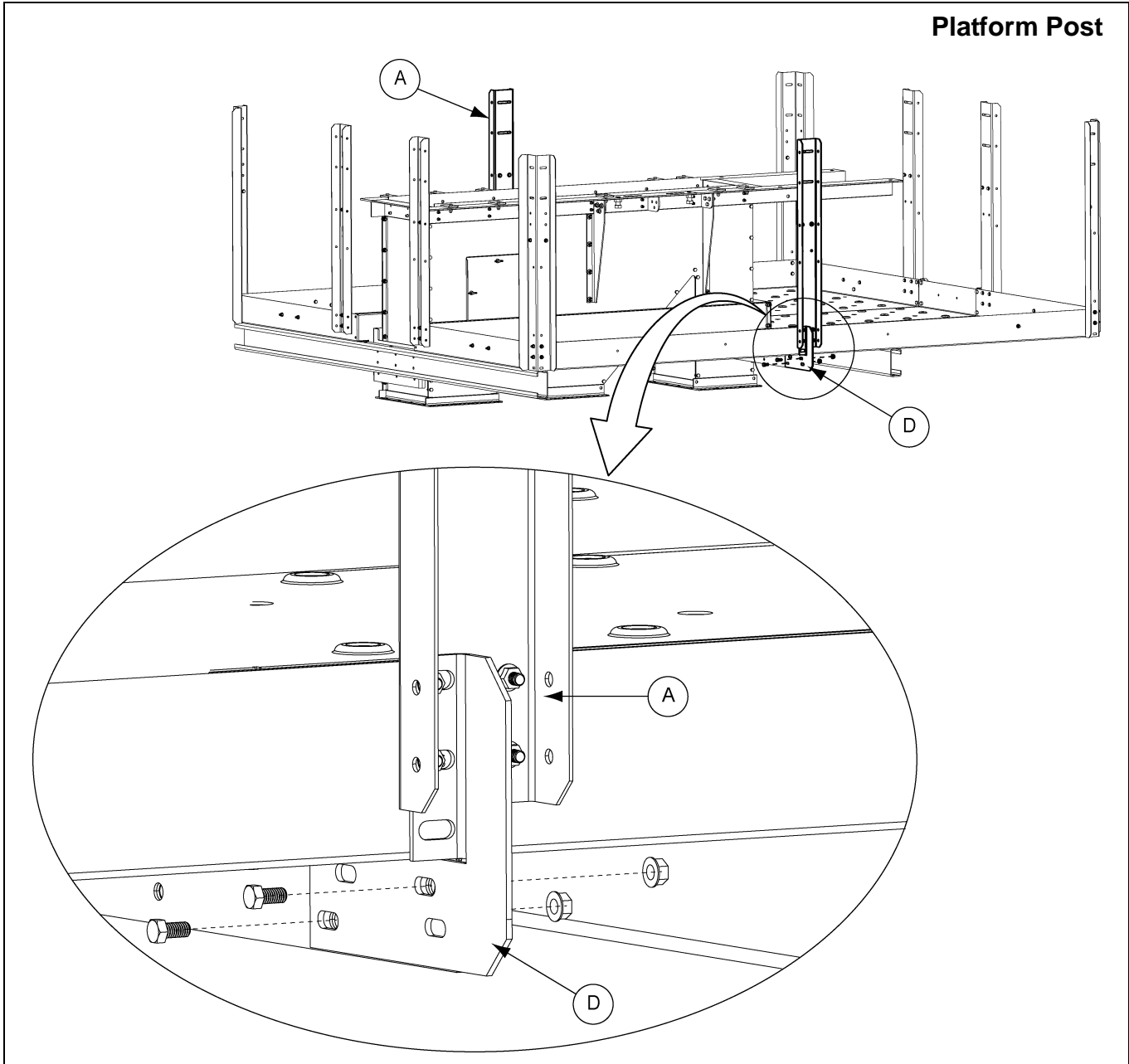

Figure 8Q Deck A Post Bracket

Ref #	Part #	Description
A	HP1648HCP	Platform Post
D	HP1648HSH	Head Platform Handrail Support

Install Intermediate Handrails

IMPORTANT: Trim each rail as listed. **Do NOT** attempt to make entire adjustment by trimming only one rail. **Each rail must be trimmed and installed as stated for proper fit.**

IMPORTANT: For safety purposes, make sure head of bolt is to the inside of platform with nuts on outside at all connections.

1. Identify and separate the large and small intermediate handrails.

NOTE: The small intermediate handrail (LDR-4088) fits inside of the large intermediate handrail. It is critical that large and small rails be properly identified in advance. Rails are cut to size and cutting the wrong rail or to the wrong length will prevent proper installation. (See Figure 8R.)

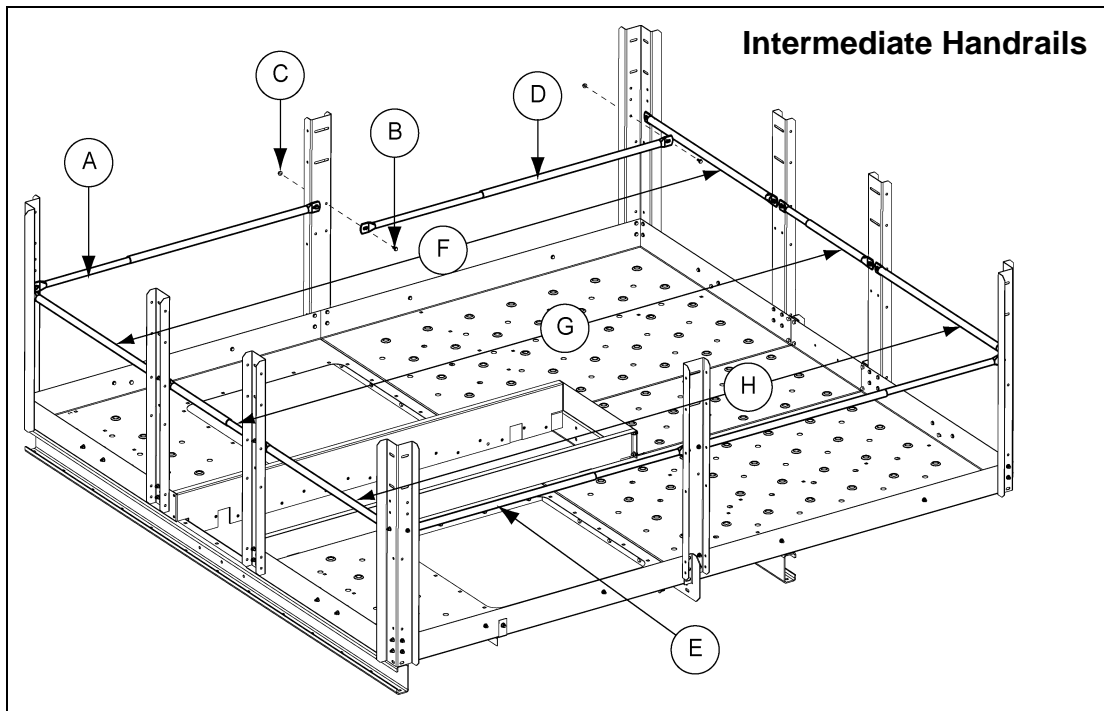

Figure 8R Intermediate Handrails

Ref #	Part #	Description
A	LDR-4088	Small Intermediate Handrail
B	S-6606	5/16" x 3/4" Flange Bolt
C	S-10268	5/16" Hex Flange Nut
D	LDR-4087	Large Intermediate Handrail
E		Hatch side large intermediate handrail needs to be at location of latch.
F		Cut 4" off of each intermediate large and small rail so the remaining length for each is 32".
G		Cut 15" off of each intermediate large and small rail so the remaining length for each is 21".
H		Cut 4" off of each intermediate large and small rail so the remaining length for each is 32".

8. 16"-24" Head Platform Assembly

Install Intermediate Handrails (Continued)

2. Trim two (2) large and two (2) small rails by 15" each so that the remaining length of each rail, both small and large, is 21". (See [Figure 8S.](#))
 - a. Install these rails across the Deck A, Deck C, Deck E side of the platform and the opposite side as shown.
 - b. Insert one small rail inside of one large rail and telescope the joined rails from the "W" corner post to the platform post as shown in [Figure 8R on Page 67.](#)
 - c. Attach to "W" posts (corner posts) and platform posts using nuts (S-10268) and bolts (S-6066).
 - d. Torque to standard specifications.

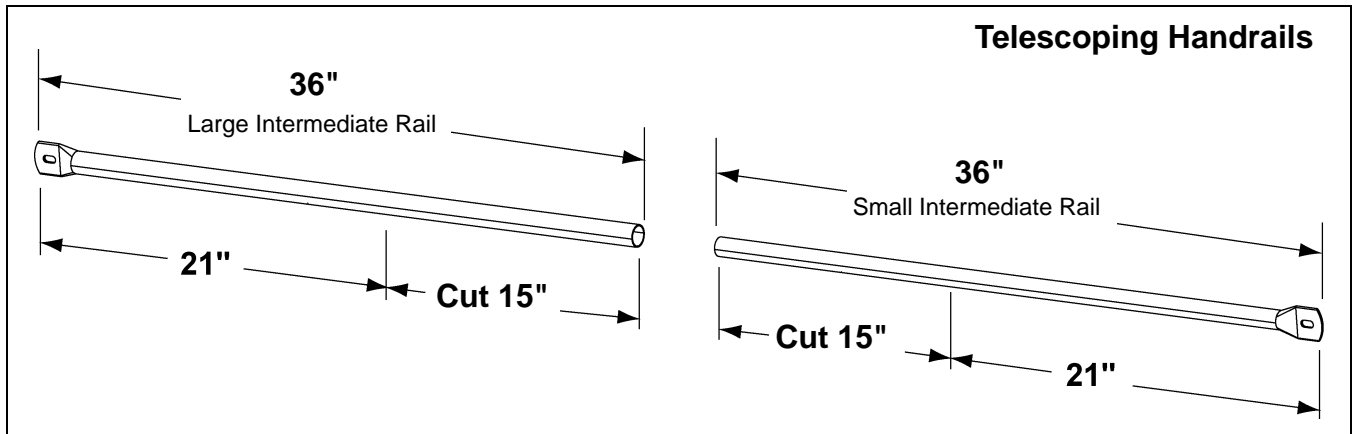

Figure 8S 21" Telescoping Handrail

3. Trim two (2) large and two (2) small rails by 4" each so remaining length of each rail, both small and large, is 32". (See [Figure 8T.](#))
 - a. Install these rails across the up-leg and down-leg sides of the platform as shown.
 - b. Insert one small rail inside of one large rail telescope the joined rails from the "W" corner posts to platform posts as shown in [Figure 8R on Page 67.](#)
 - c. Attach to "W" posts (corner posts) and platform posts using nuts (S-10268) and bolts (S-6066).
 - d. Torque to standard specifications.

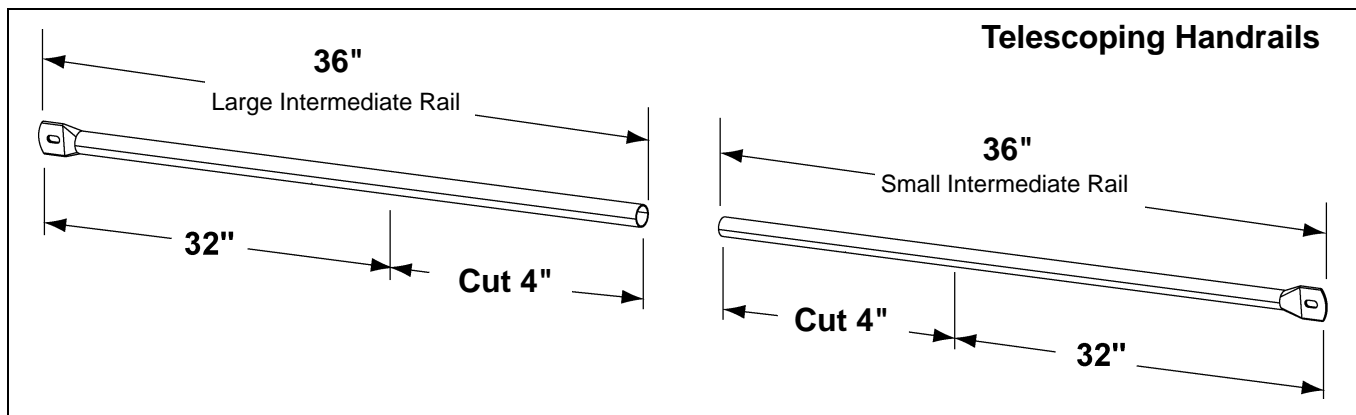

Figure 8T 32" Telescoping Handrail

Install Upper Handrails

IMPORTANT: For safety purposes, make sure head of bolts is to the inside of platform with nuts on outside at all connections.

NOTE: Upper handrails do not require any cutting prior to installation.

1. Attach two (2) 25.6" in length middle drive handrails (HP1624HMD) along Deck E and the lower head. These are the two (2) shortest sections of upper handrail. Connect using 5/16" nuts (S-10268) and 5/16" x 2" bolts (S-7877). (See Figure 8U.)
2. Attach four (4) hatch handrails (HP1648HHS): one on each side of the middle drive at each end of the platform. Handrails will fit without adjustment. Connect using 5/16" nut (S-10268) and 5/16" x 2" bolts (S-7877). Torque to standard specifications.
3. Two (2) 59.183" far hatch handrails (HP1624HFH) and two (2) 54.65" handrails (HP1624HNNH) opposite each other along Deck A and Deck C using 5/16" x 2" bolts (S-7877) and 5/16" nuts (S-10268).

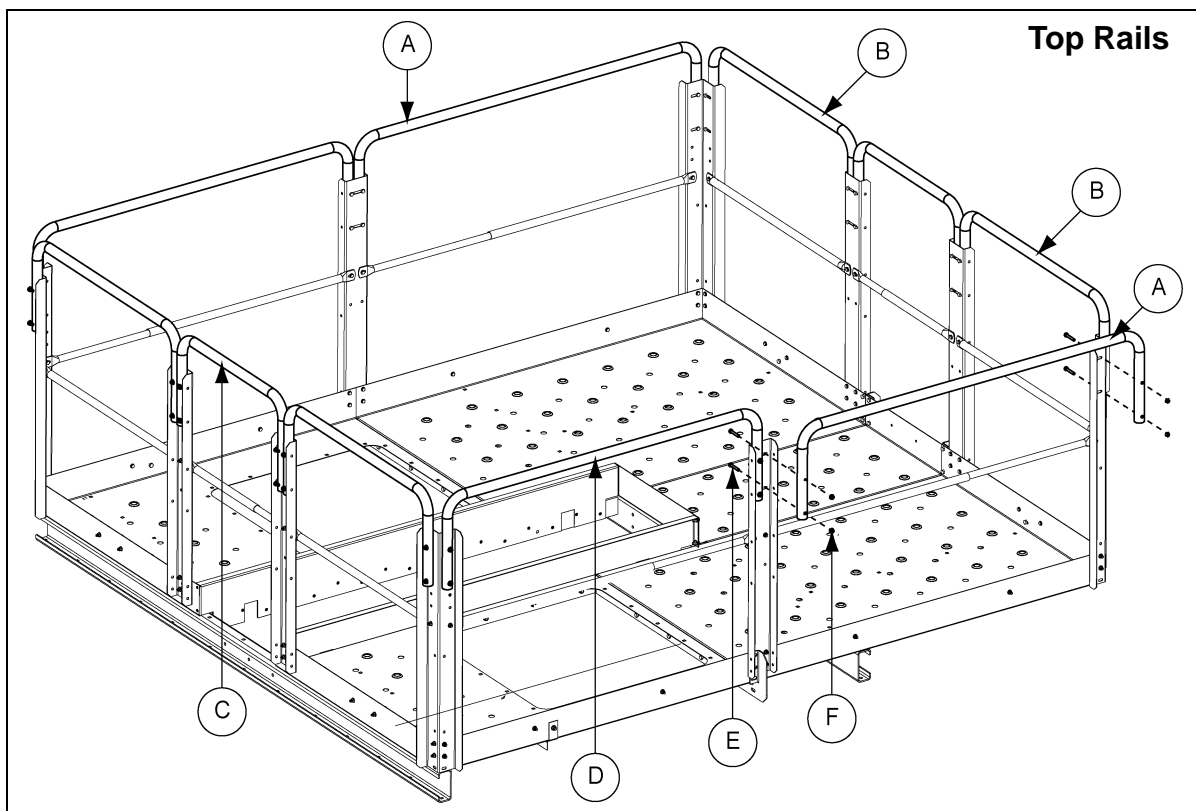

Figure 8U Top Rails

Ref #	Part #	Description
A	HP1624HFH	59.183" Far Hatch Handrail
B	HP1648HLH	36.895" Hatch Handrail
C	HP1648HMD	26.7" Middle Drive Handrail
D	HP1624HNNH	54.65" Near Hatch
E	S-7877	5/16" x 2" Bolt
F	S-10268	5/16" Flange Nut

8. 16"-24" Head Platform Assembly

Install Tie Braces (Safety Cage Bars)

NOTE: Safety cage bars (LDR-5171BE) are used as tie braces in this installation.

IMPORTANT: For safety purposes, make sure head of bolts are to the inside of platform with nuts on outside at all connections.

1. At each of the four (4) "W" corner posts (HP1648HWP), attach two (2) tie braces (safety cage bar LDR-5171BE) from the lower half of the post to the deck kick plate using 5/16" nuts (S-10268) and 5/16" x 3/4" flange bolts (S-6606). (See Figure 8V.)

NOTE: Tie braces may be oriented on the inside or outside of the decking kick plates based upon installer preference.

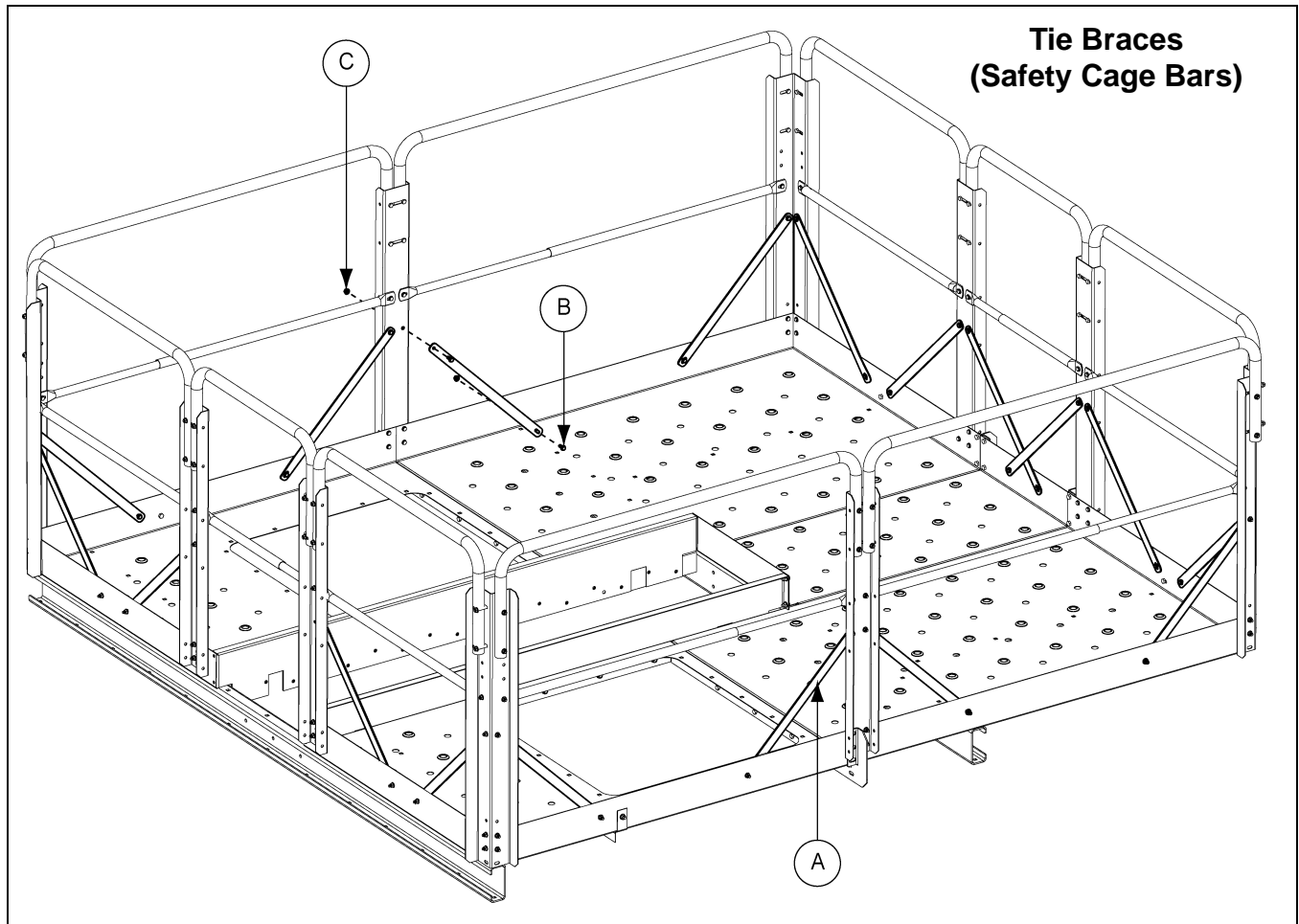

Figure 8V Safety Cage Cross Brace

Ref #	Part #	Description
A	LDR-5171BE	24" Safety Cage Bar
B	S-6606	5/16" x 3/4" Flange Bolt
C	S-10268	5/16" Hex Flange Nut

NOTE: See Page 71 for hatch door installation.

Chapter 9: Install Hatch

1. Attach hatch hinge (HP1624HH) to the hatch deck door (HP1624HDD). Orient hinge so that it opens the desired direction. (See Figure 9A.) Fasten using 3/8" x 1" carriage bolts hardware.

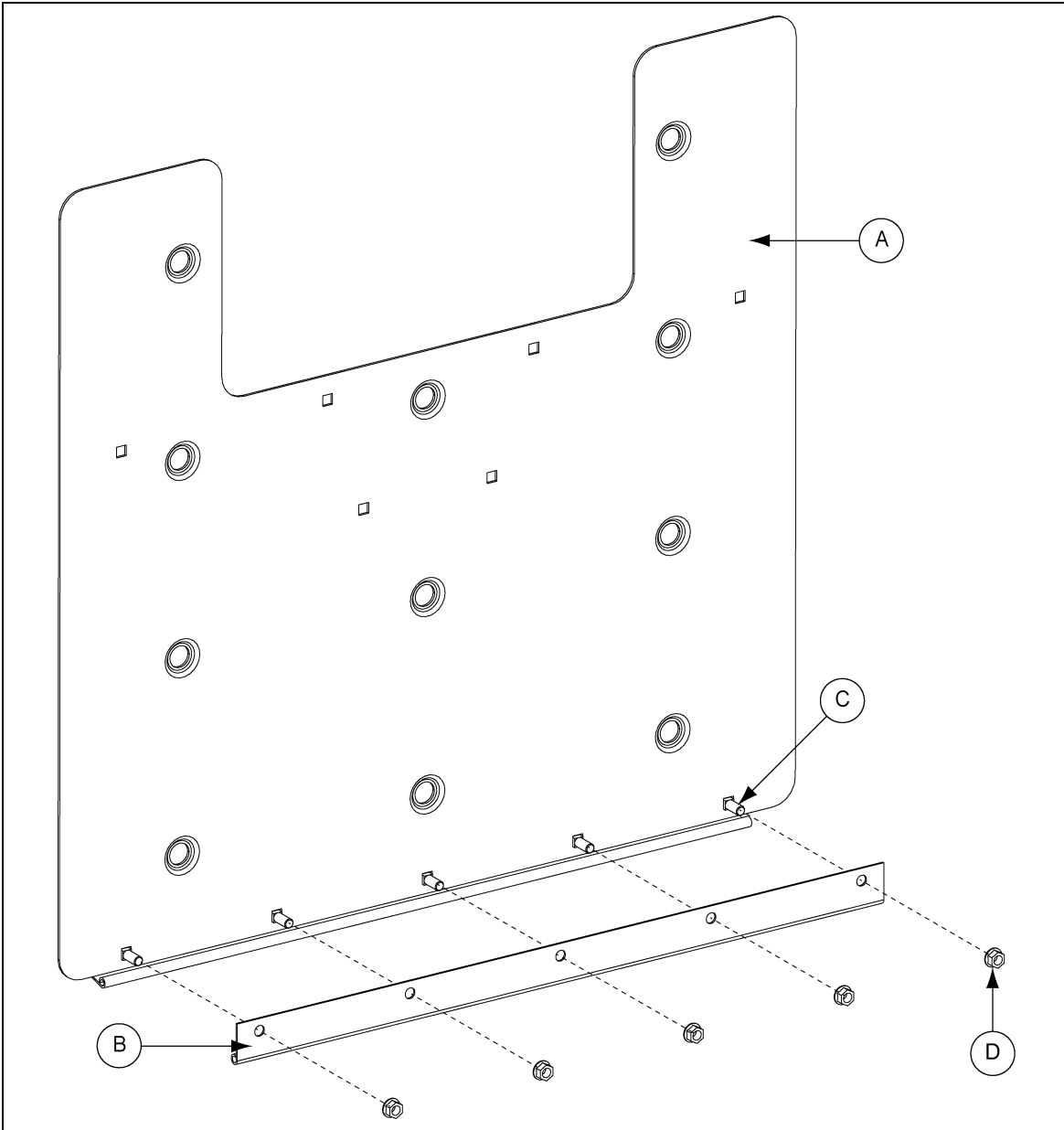

Figure 9A

Ref #	Part #	Description
A	HP1624HDD	Hatch Deck Door
B	HP1624HH	Hatch Hinge
C	S-3585	3/8" x 1" Carriage Bolt
D	S-10028	3/8" Hex Nut

9. Install Hatch

Install Hatch (Continued)

2. Install hatch support (HP1624HS) to the bottom of the hatch door using 3/8" x 1" carriage bolts and nuts. (See Figure 9B.)
3. Fasten peak cap handle (PR-331) to the bottom of the hatch door using 3/8" x 1" carriage bolts and nuts.

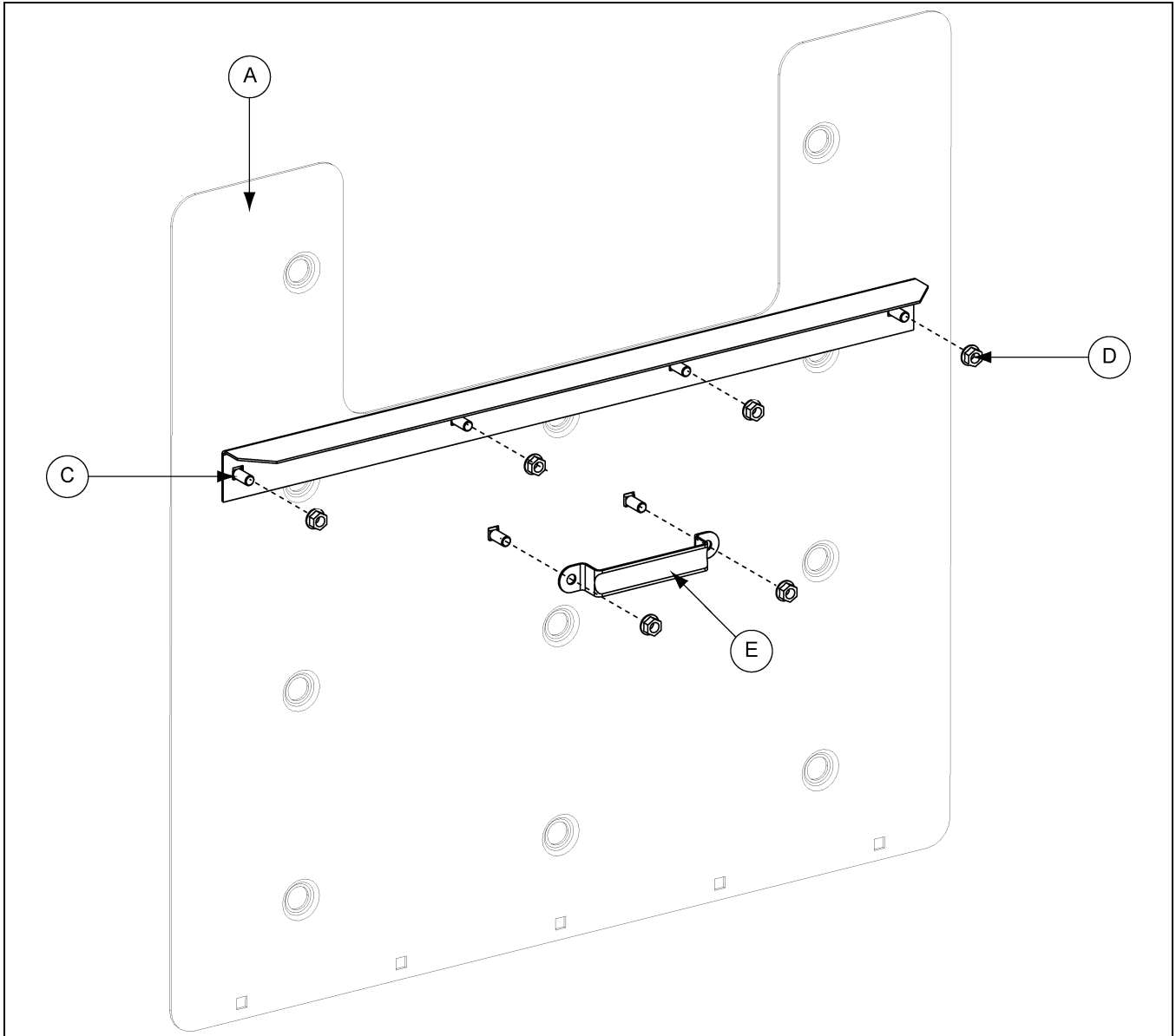

Figure 9B

Ref #	Part #	Description
A	HP1624HDD	Hatch Deck Door
C	S-3585	3/8" x 1" Carriage Bolt
D	S-10028	3/8" Hex Nut
E	RP-331	Peak Cap Handle

Install Hatch (Continued)

- Slide two (2) magnets (16-0092) onto each MS #6 x 3/4" FHS flat head screw (S-7166). Position the magnet so the screw head is countersunk into the magnet. (See Figure 9C.)
- Insert screws with magnets through the hatch door and fasten with the #6 flange nut (S-10133).

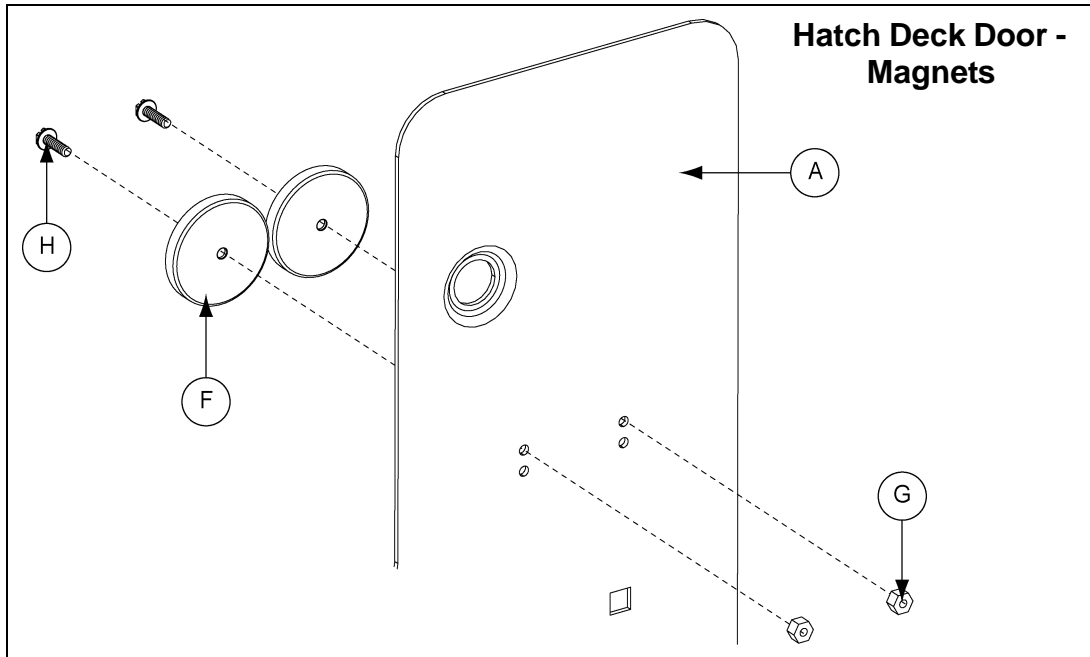

Figure 9C

Ref #	Part #	Description
A	HP1624HDD	Hatch Deck Door
F	HP1648MAG	Magnet

Ref #	Part #	Description
G	S-2010	Nylock Nut #10-24 ZN Grade 2
H		Screw, MS #10-24 x 5/8" HWHS ZN Grade 2

- Align holes on the hatch hinge with holes along the deck opening closest to the kick plates. Install the hatch door to the decking using 3/8" x 3/4" bolts (S-7105) and nuts. (See Figure 9D.)

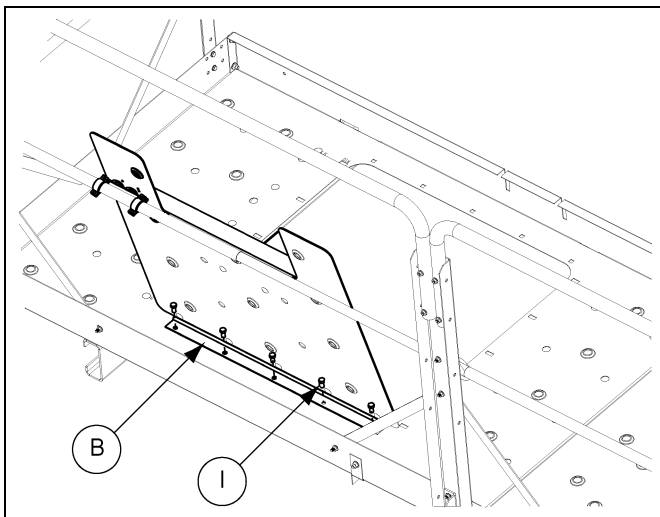

Figure 9D

Ref #	Part #	Description
B	HP1624HH	Hatch Hinge
I	S-7105	3/8" x 3/4" Bolt

9. Install Hatch

Install Hatch (Continued)

7. Assemble pipe clamps (S-10139) to the magnet mount hatch bracket (HP1648LMM). Insert 3/8" x 3/4" carriage bolts through the magnet mount hatch bracket, 1/2" flat washer and pipe clamp. Fasten with 3/8" nut. (See Figure 9E.)
8. Attach pipe clamp around intermediate handrail and fasten loosely with bolts. Open hatch plate and slide clamp along handrail until it lines up with the magnets on the hatch plate. Tighten clamp to rail.

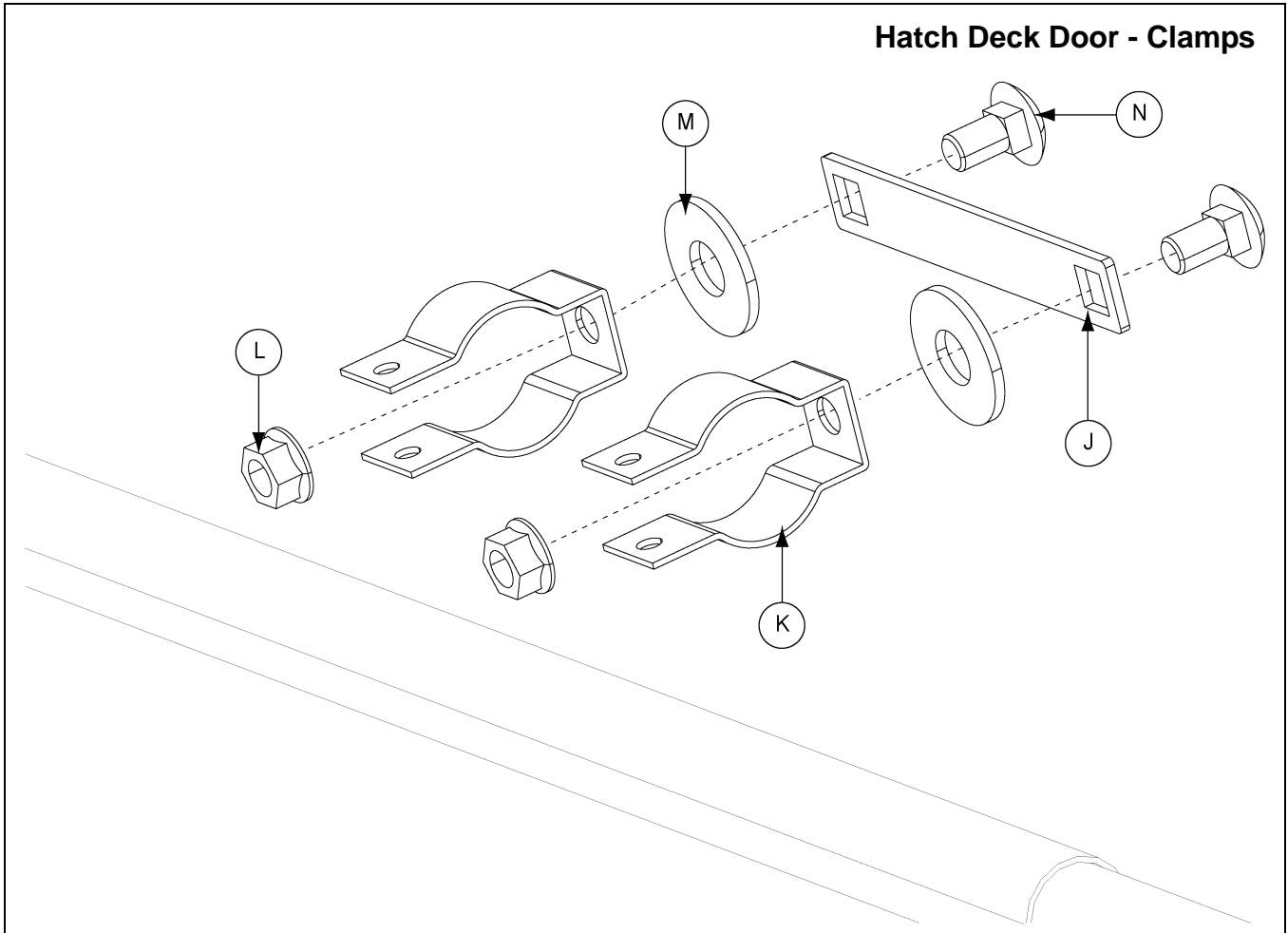

Figure 9E

Ref #	Part #	Description
J	HP1648LMM	Magnet Mount Hatch Bracket
K	S-10139	Pipe Clamp 1" O.D. 3/8" Holes with Screw
L		3/8" Nut
M		1/2" Flat Washer
N		3/8" x 3/4" Carriage Bolt

Chapter 10: 4 x 5 Distributor Platform (Optional)

The distributor platform is optional and only used on bucket elevators that have a distributor spout. The platform is used to access the distributor for maintenance and control adjustments. The platform should be located below the distributor head. **NOTE:** That the clamp installation to the trunking is different for 16", 24" and the 30"-36" but the rest of the assembly is the same.

16"-24" Clamp Band Installation

Attach Top Clamp Band to Trunking (for 24" Instructions, see [Steps 3 and 4.](#))

1. Slide rods of clamp rod weldment into inside set of holes of clamp bands for 16" assembly. Fasten together using four (4) 1/2" hex flange nuts.
2. Line up the holes on the clamp strut with the set of holes closest to the bend on both of the 16"-24" long clamp clips and fasten all three (3) together using four (4) 1/2" x 1" bolts and nuts. This will create the clamp strut assembly.
3. Assemble the clamp band weldment, clamp channel and clamp strut assembly at one time around the trunking. Place clamp rod weldment assembly around the trunking leg and line up holes on 16"-24" long clips and clamp channel with the **outside set of holes** on the clamp rod weldment. Fasten all three (3) together using six (6) 1/2" x 1" bolts and nuts.
4. Line up the holes located at the end of the distributor support channels with the holes at the end of the 16"-24" long clamp clips. Fasten the support channels to the long clamp clips using four (4) 1/2" x 1" bolts and nuts. (See [Figure 10A.](#))

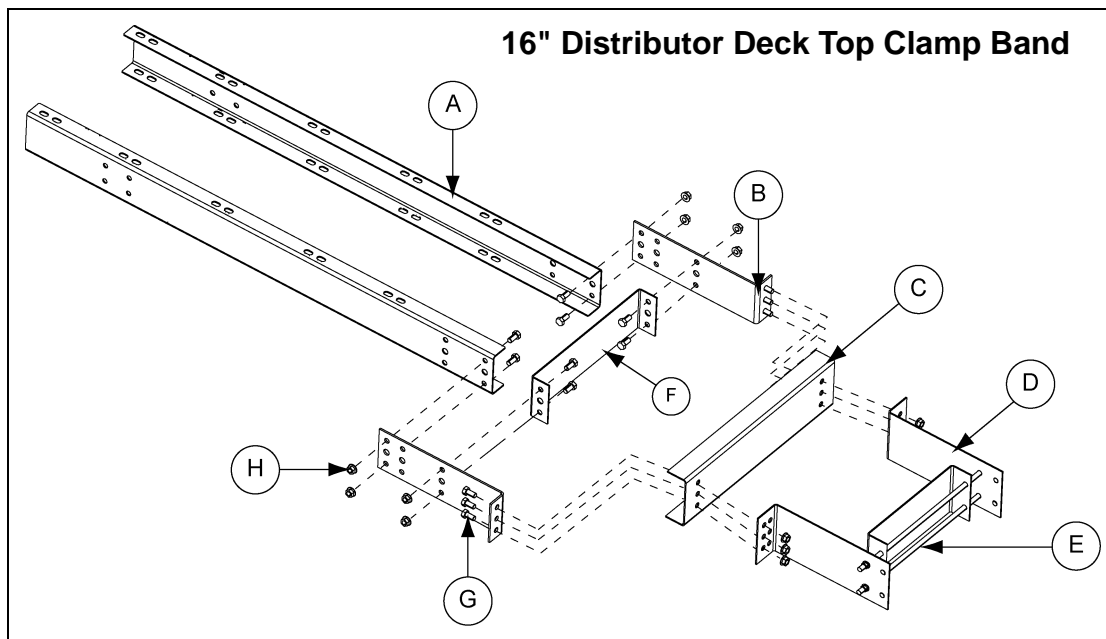

Figure 10A

Ref #	Part #	Description
A	GSB30210X	Distributor Support Channel (+5")
B	DSP1624TRF	Long Clamp Clip for 16"-24"
C	DSP16001	Clamp Channel
D	DSP16002	Distributor Clamp Band

Ref #	Part #	Description
E	DSP16005	Clamp Rod Weldment
F	DSP1624RFS	Clamp Strut for 16" Trunking
G	S-7935	1/2" x 1" Bolt
H	S-8506	1/2" Flange Nut

10. 4 x 5 Distributor Platform (Optional)

16" Attach Bottom Clamp Band to Trunking (for 24" Instructions, see [Steps 2 and 3.](#))

1. Slide rods of clamp rod weldment into inside set of holes of clamp bands for 16" assembly. Fasten together using four (4) 1/2" hex flange nuts.
2. Line up the holes on one of the clamp struts with the set of holes closest to the bend on both of the 16"-24" long clamp clips and fasten all three (3) together using four (4) 1/2" x 1" bolt and nuts. Tighten only finger tight. Next orient the brace channels so the bends face outwards and line up the brace channel holes with the holes located at the end of the long clamp clips and the remaining clamp strut. Fasten all five (5) parts together using four (4) 1/2" x 1" bolt and nuts. Tighten finger tight. This will make up the brace channel assembly.
3. Assemble the clamp rod weldment, clamp channel and brace channel assembly at same time around the trunking. Place clamp rod weldment assembly around the trunking leg and line up holes on 16"-24" long clips and clamp channel with the **outside set of holes** on the clamp rod weldment. Fasten all three (3) together using six (6) 1/2" x 1" bolts and nuts. ([See Figure 10B.](#))

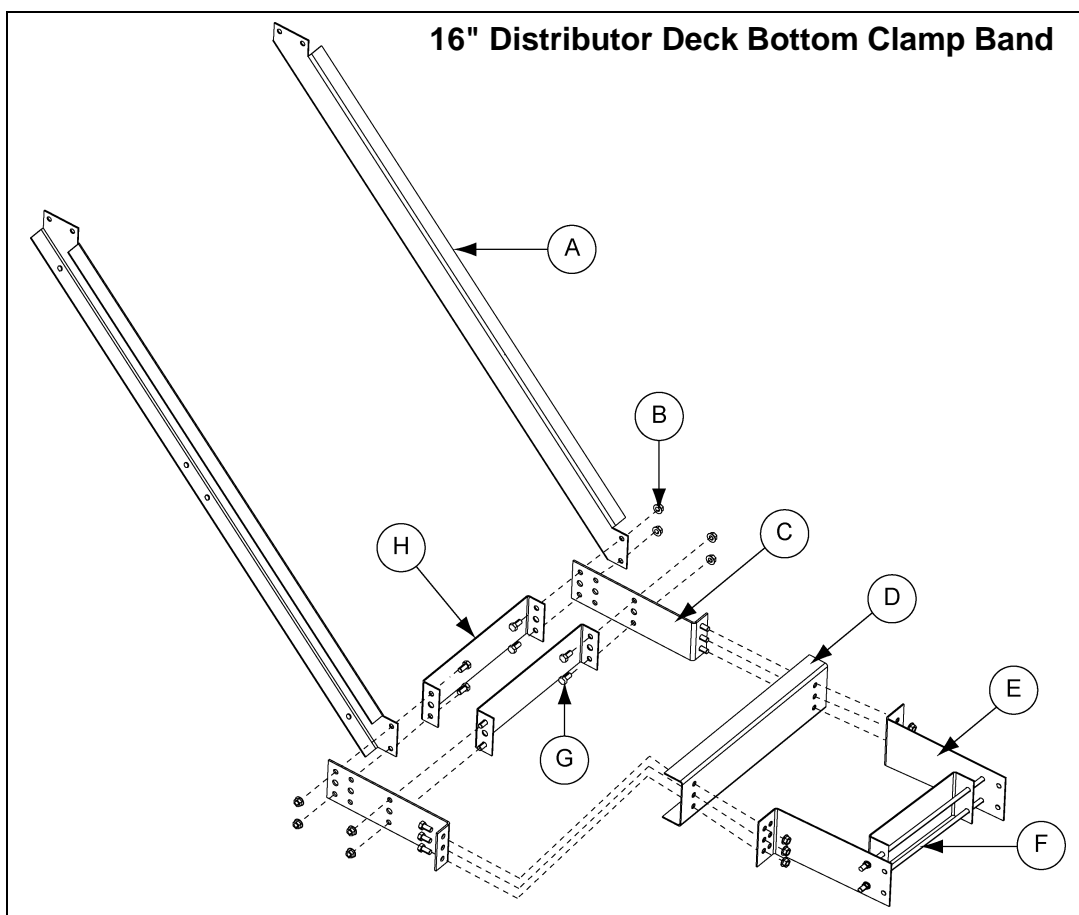

Figure 10B

Ref #	Part #	Description
A	GSB30147	Brace Channel
B	S-8506	1/2" Hex Flange Nut
C	DSP1624TRF	Long Clamp Clip for 16"-24"
D	DSP16001	Clamp Channel

Ref #	Part #	Description
E	DSP16002	Distributor Clamp Band
F	DSP16005	Clamp Rod Weldment
G	S-7935	1/2" x 1" Bolt
H	DSP1624TRFS	Clamp Strut for 16"-24" Trunking

24" Attach Top Clamp Band to Trunking

1. Slide rods of clamp rod weldment into inside set of holes of clamp bands for 24" assembly. Fasten together using four (4) 1/2" hex flange nuts.
2. Line up the holes on the support channels with the inside set of holes on the 16"-24" long clamp clips and fasten all four (4) together using eight (8) 1/2" x 1" bolt and nuts.
3. Assemble the 16"-24" long clamp assembly, clamp channel and clamp rod assembly at same time around the trunking. Place clamp rod weldment assembly around the trunking leg and line up holes on 16"-24" long clips and clamp channel with the **outside set of holes** on the clamp rod weldment. Fasten all three (3) together using six (6) 1/2" x 1" bolts and nuts. (See Figure 10C.)

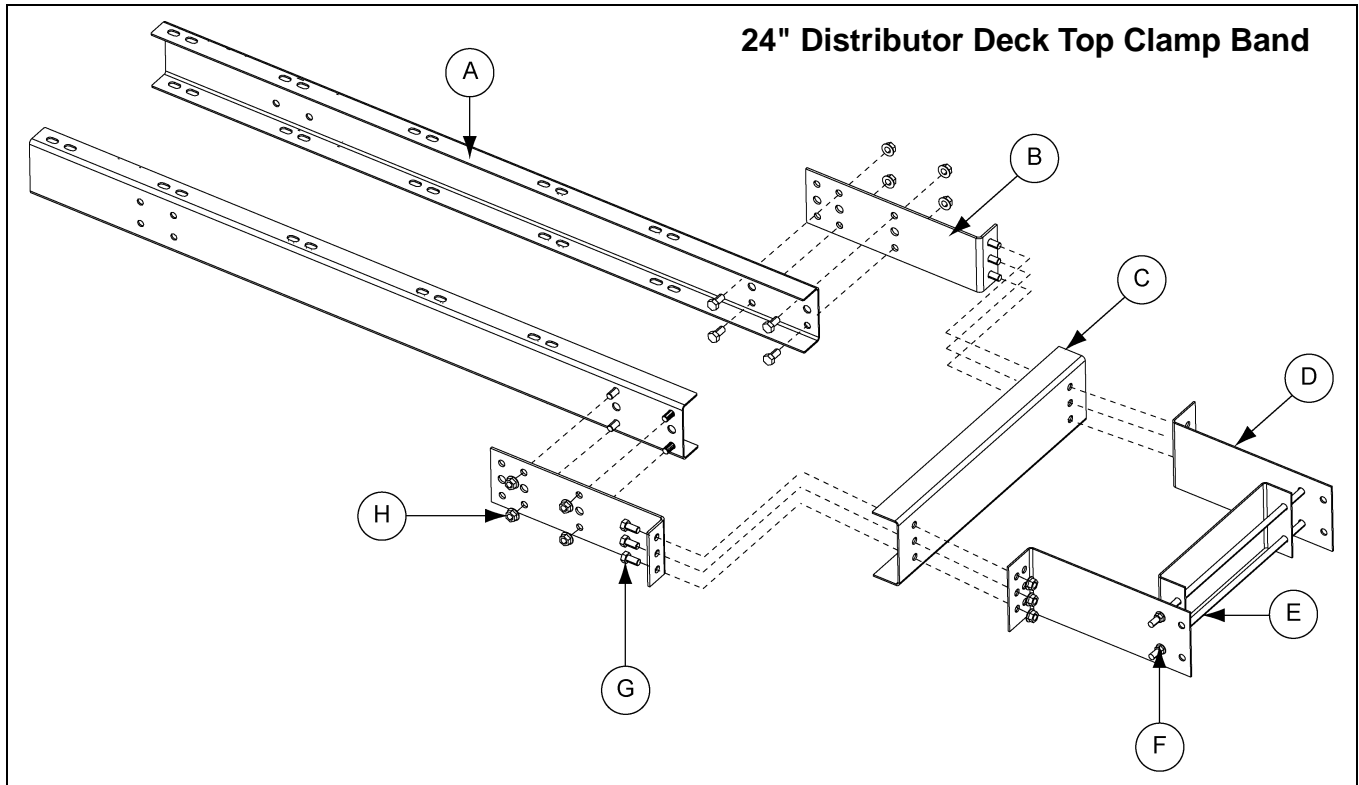

Figure 10C

Ref #	Part #	Description
A	GSB30210X	Distributor Support Channel (+5")
B	DSP1624TRF	Long Clamp Clip for 16"-24"
C	DSP16001	Clamp Channel
D	DSP16002	Distributor Clamp Band
E	DSP16005	Clamp Rod Weldment
F	S-8506	1/2" Hex Flange Nut
G	S-7935	1/2" x 1" Bolt
H	S-8506	1/2" Flange Nut

10. 4 x 5 Distributor Platform (Optional)

24" Attach Bottom Clamp Band to Trunking and Knee Brace

1. Slide rods of clamp rod weldment into inside set of holes of clamp bands for 16" assembly. Fasten together using four (4) 1/2" hex flange nuts.
2. Orient the brace channels so the bends face outwards and line up the brace channel holes with the holes located near the middle of the 16"-24" long clamp clips. Line up the clamp strut with the same set of holes as the brace channel and 16"-24" long clamp clip. Fasten all five (5) together using four (4) 1/2" x 1" bolts and nuts. Attach remaining clamp strut to the end of the 16"-24" clamp clip. Tighten only finger tight. (See Figure 10D.)
3. Assemble the clamp rod weldment, clamp channel and brace channel assembly at same time around the trunking. Place clamp rod weldment assembly around the trunking leg and line up holes on 16"-24" long clips and clamp channel with the **outside set of holes** on the clamp rod weldment. Fasten all three (3) together using six (6) 1/2" x 1" bolts and nuts.

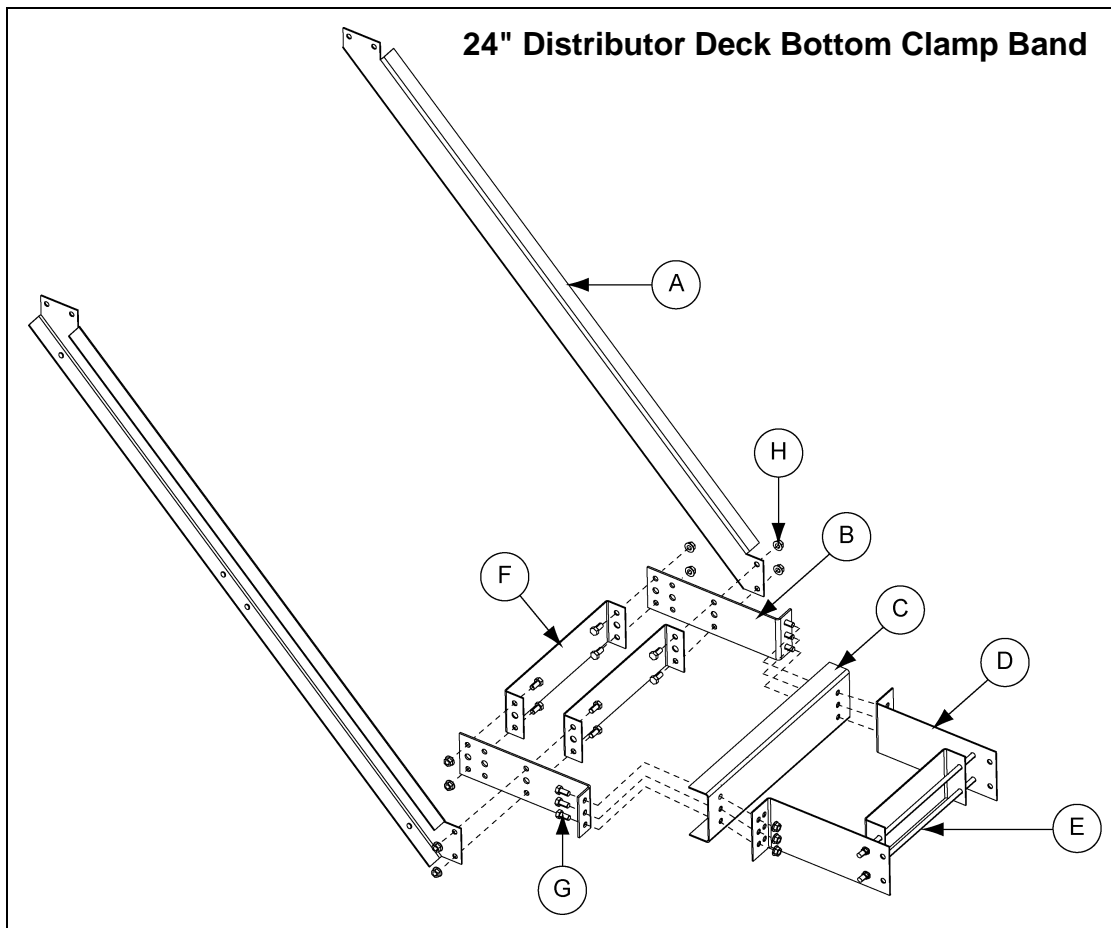

Figure 10D

Ref #	Part #	Description
A	GSB30147	Brace Channel
B	DSP1624TRF	Long Clamp Clip for 16"-24"
C	DSP16001	Clamp Channel
D	DSP16002	Distributor Clamp Band

Ref #	Part #	Description
E	DSP16005	Clamp Rod Weldment
F	DSP1624TRFS	Clamp Strut for 16"-24" Trunking
G	S-7935	1/2" x 1" Bolt
H	S-8506	1/2" Hex Flange Nut

Assemble Supports (16"-24")

1. Attach brace channels to the sides of the support channels using four (4) 1/2" x 1" bolts and nuts. Angle the knee braces across the bottom sides of the brace channels and attach using four (4) 1/2" x 1" bolts and nuts.
2. Assemble the cross supports to the bottom side of the support channels using the end and middle sets of holes on the support channels using four (4) 1/2" x 1" bolts and nuts. (See Figure 10E.)
3. Assemble the external platform support (DSP1648EPS) to the end of the three (3) cross supports using six (6) 1/2" x 1" bolts and nuts. (See Figure 10F on Page 80.)

NOTE: For 24" installation the lower knee brace will use the second hole on the brace and the second hole up from the bottom on the brace channel. (See Figure 10G on Page 80.)

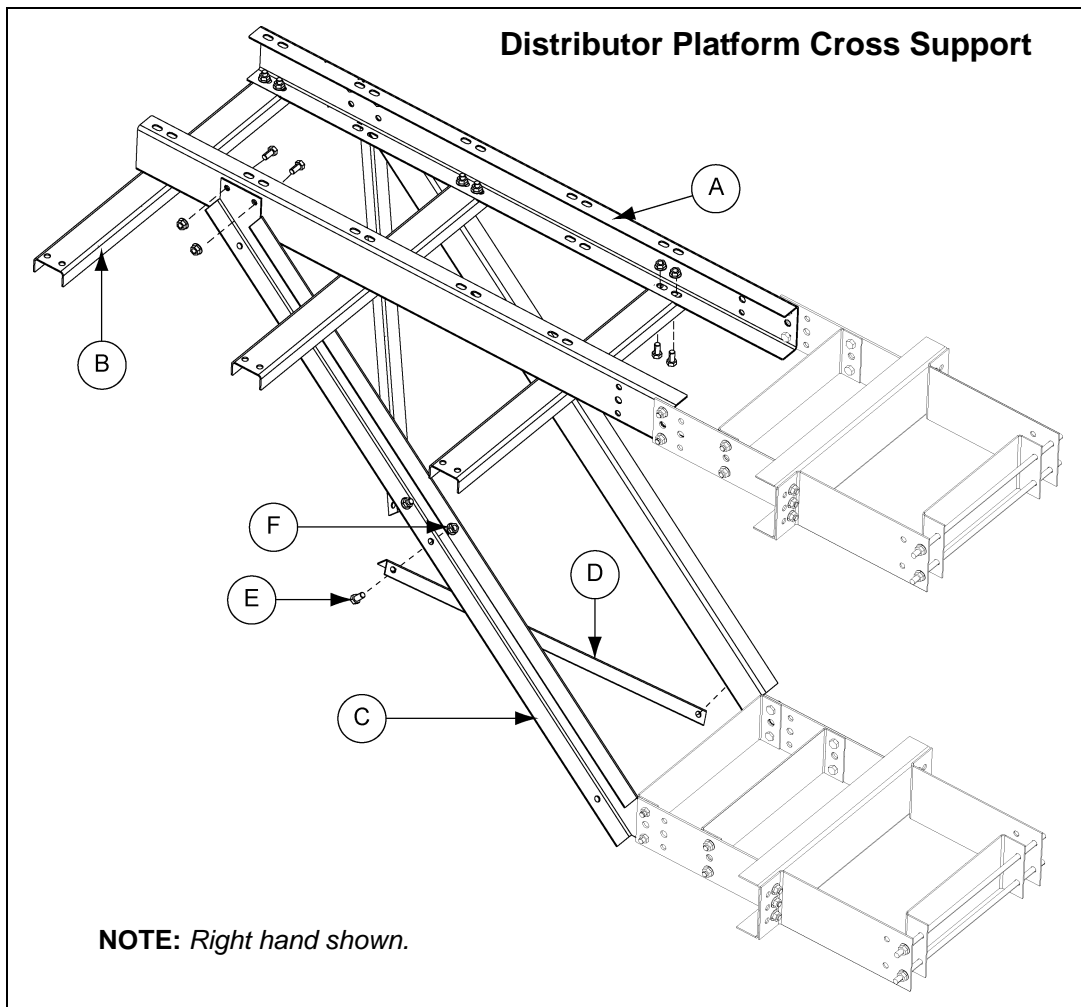

Figure 10E Distributor Platform Cross Support

Ref #	Part #	Description
A	GSB30210X	Distributor Support Channel (+5")
B	DSP1648CS	Distributor Platform Cross Support
C	GSB30147	Brace Channel

Ref #	Part #	Description
D	GSB30148	Knee Brace
E	S-7935	1/2" x 1" Bolt
F	S-8506	1/2" Hex Flange Nut

10. 4 x 5 Distributor Platform (Optional)

Assemble Supports (16"-24") (Continued)

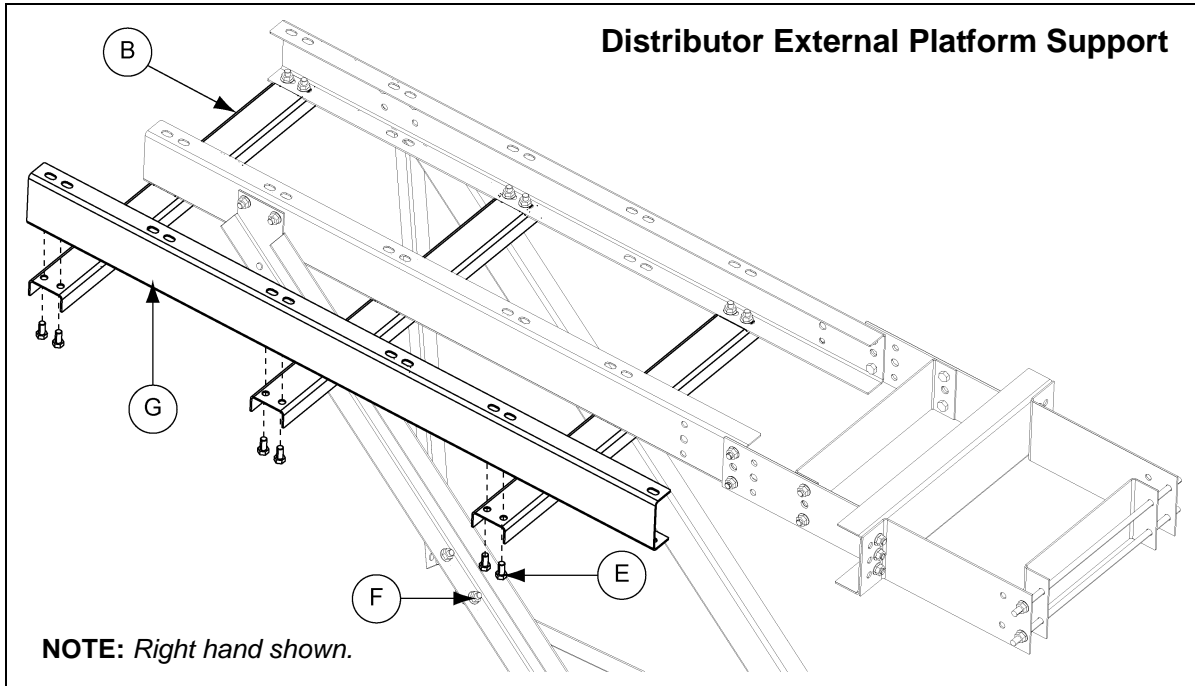
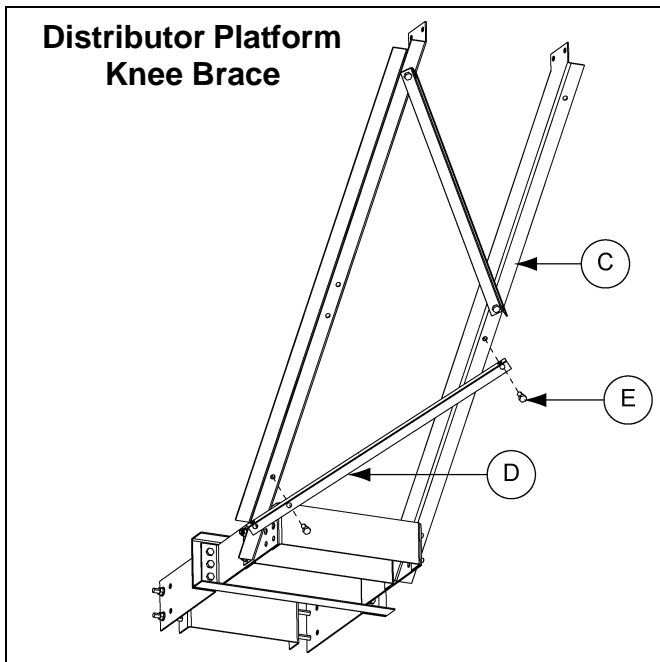

Figure 10F Distributor External Platform Support

Ref #	Part #	Description
B	DSP1648CS	Distributor Platform Cross Support
E	S-7935	1/2" x 1" Bolt

Ref #	Part #	Description
F	S-8506	1/2" Hex Flange Nut
G	DSP1648EPS	Distributor External Platform Support



Ref #	Part #	Description
C	GSB30147	Brace Channel
D	GSB30148	Knee Brace
E	S-7935	1/2" x 1" Bolt

Figure 10G 24" Distributor Platform Knee Brace

Assemble Decking and “W” Corner Post

1. Align A6 and A8 on platform decking weldment with A6 and A8 on the external platform supports.
2. Install platform decking weldment to the platform support channels using twenty four (24) 1/2" x 1" bolt and nuts. (See Figure 10H.)
3. Attach the flange of the toe board short side to the bottom of the 18" decking using two (2) 1/2" x 1" bolt and nuts. Then attach 18" decking to the external platform support using one 1/2" x 1" bolt and nut. (See Figure 10J on Page 82.)
4. Align flange of end toe board along the bottom of decking. Connect end toe board to decking using 1/2" x 1" bolts and nuts. (See Figure 10I on Page 82.)
5. Install the corner “W” post at the same time as the toe board filler plate. Attach toe board filler plate to the decking toe boards located across from the entrance. Attach the flat end first using two (2) 5/16" x 3/4" flange bolts and nuts. Then line up the holes of the toe board filler plate with the decking toe board, while also aligning the holes of the “W” post on the corner. Fasten all three (3) together with four (4) 5/16" x 3/4" flange bolts and nuts. (See Figure 10K on Page 83.)

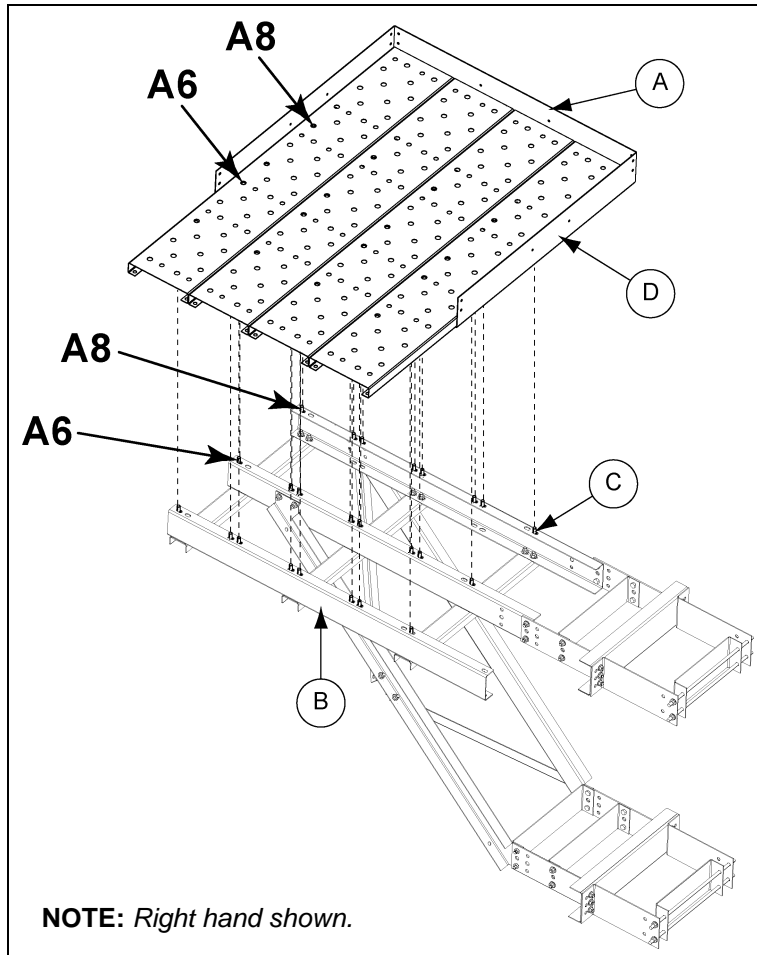

Figure 10H

Ref #	Part #	Description
A	GSB30141X	Platform Deck Weldment
B	DSP1648EPS	Distributor External Platform Support

Ref #	Part #	Description
C	S-7935	1/2" x 1" Bolt
D	S-8506	1/2" Hex Flange Nut

10. 4 x 5 Distributor Platform (Optional)

Assemble Decking and “W” Corner Post (Continued)

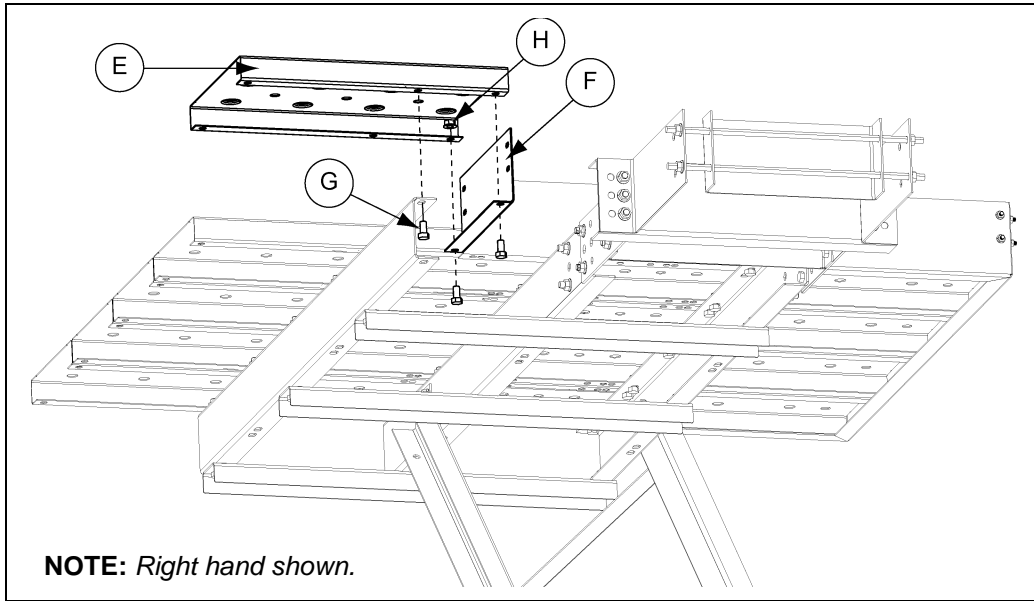

Figure 10I

Ref #	Part #	Description
E	DSP1648DEX	18" Decking
F	GSB36256	Toe Board Short Side

Ref #	Part #	Description
G	S-7935	1/2" x 1" Bolt
H	S-8506	1/2" Hex Flange Nut

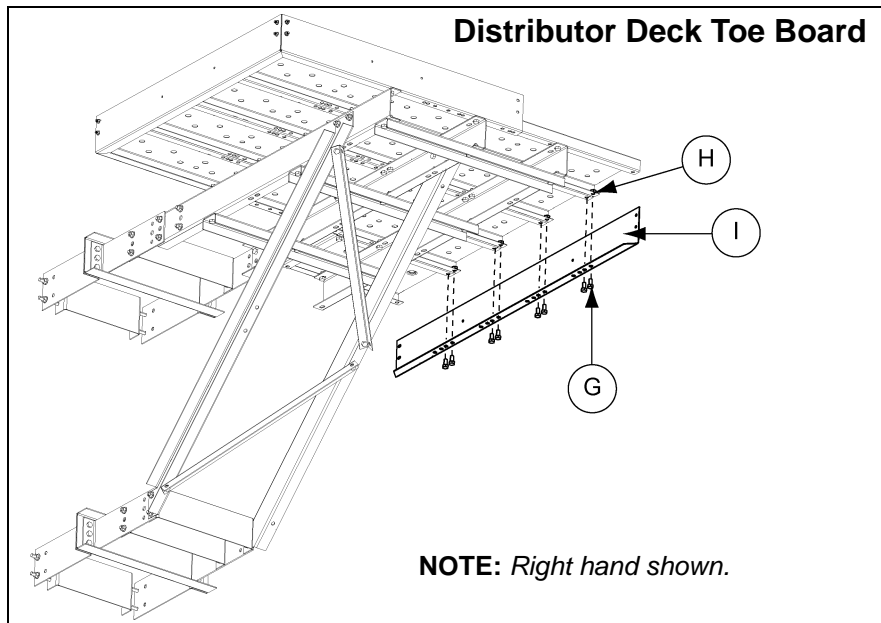

Figure 10J 16" Distributor Platform Toe Board

Ref #	Part #	Description
G	S-7935	1/2" x 1" Bolt
H	S-8506	1/2" Hex Flange Nut
I	GSB30136X	End Toe Board

Assemble Decking and “W” Corner Post (Continued)

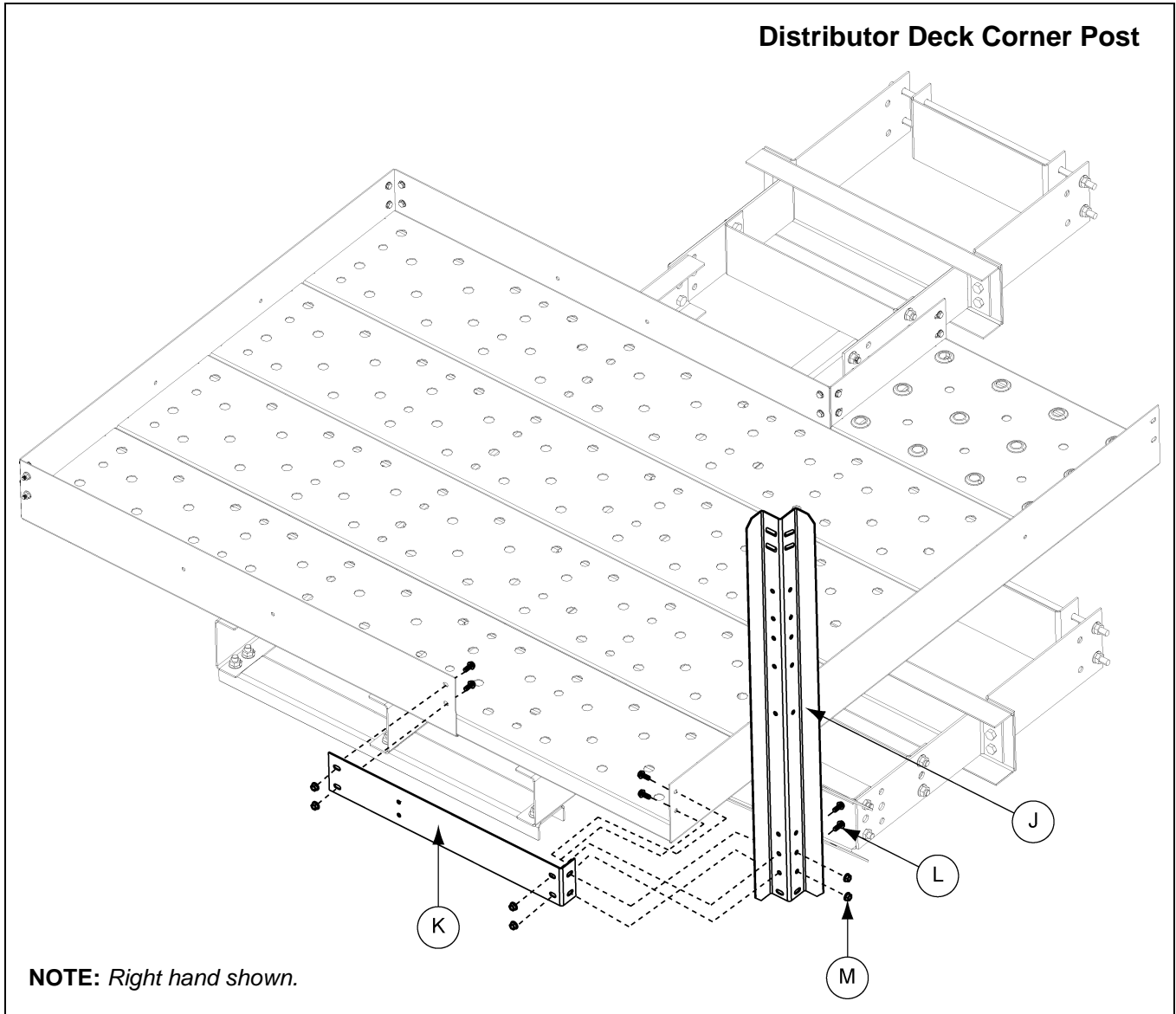

Figure 10K Distributor Platform Corner Post

Ref #	Part #	Description
J	HP1648HWP	Head/Distributor “W” Post
K	GSB30142X	Toe Board Filler Plate
L	S-6606	5/16" x 3/4" Flange Bolt
M	S-10268	5/16" Hex Flange Nut

10. 4 x 5 Distributor Platform (Optional)

Install Handrail Posts - Non-Entrance Side

1. Install the remaining two (2) "W" corner posts to the corners on the non-entrance side of the decking using four (4) 5/16" x 3/4" flange bolts and nuts per post.
2. Install platform post (HP1648HCP) to the inside corner of the decking near the entrance to the platform using four (4) 5/16" x 3/4" flange bolts and nuts.
3. Attach side posts (HP1648HP) to the decking at the entrance to the platform using two (2) 5/16" x 3/4" flange bolts and nuts per post. *(See Figure 10L.)*
4. Install distributor handrail support to the side post on the inside, located closest to the trunking through holes 3 and 4 counting from the top of the post. Use two (2) 5/16" x 3/4" flange bolts and nuts to fasten in place. *(See Figure 10L.)*

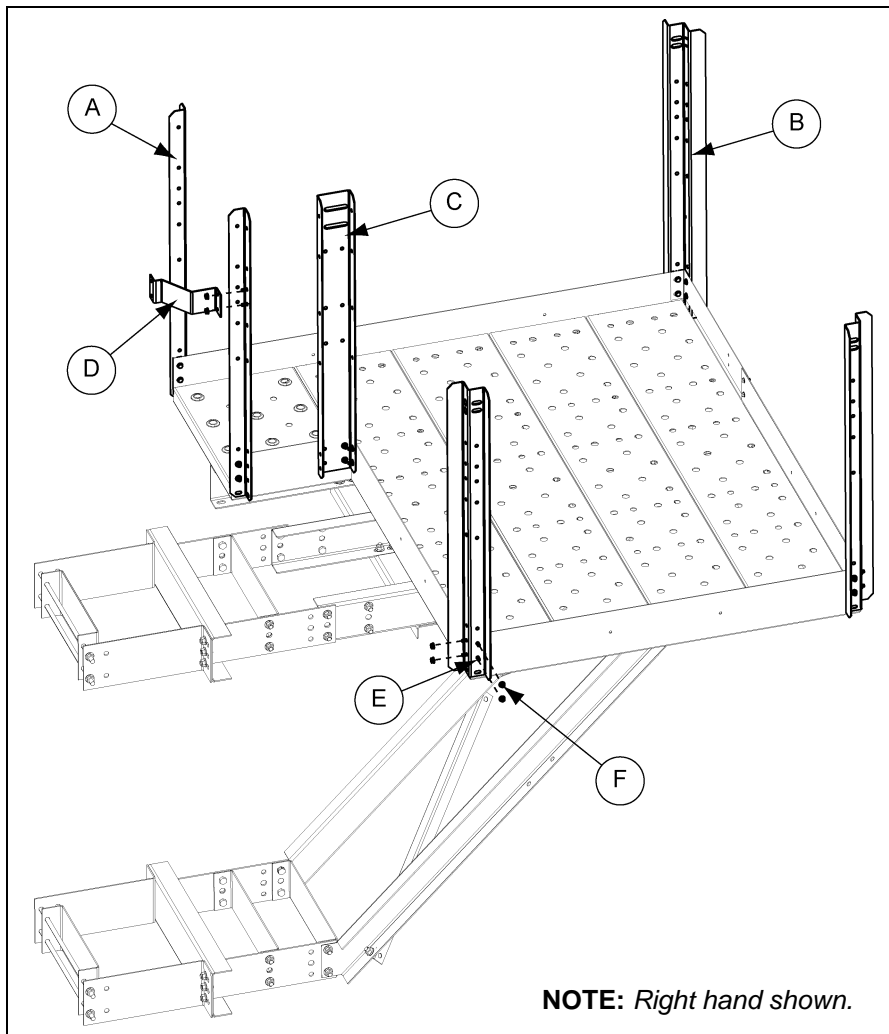

Figure 10L

Ref #	Part #	Description
A	HP1648HP	Head/Distributor Side Post
B	HP1648HWP	Head/Distributor "W" Post
C	HP1648HCP	Platform Post

Ref #	Part #	Description
D	DSP1648HS	Distributor Handrail Support
E	S-6606	5/16" x 3/4" Flange Bolt
F	S-10268	5/16" Flange Nut

Install Intermediate Handrails

1. Insert small intermediate handrail into the large intermediate handrails to create telescoping rails. Cut 30" off one small intermediate and one large intermediate rail to fit at entrance. Adjust all rails to the proper length and install to the posts using the 5th hole down from the top. Fasten in place using two (2) 5/16" x 3/4" flange bolts and nuts per each telescoping tube. *(See Figure 10M.)*

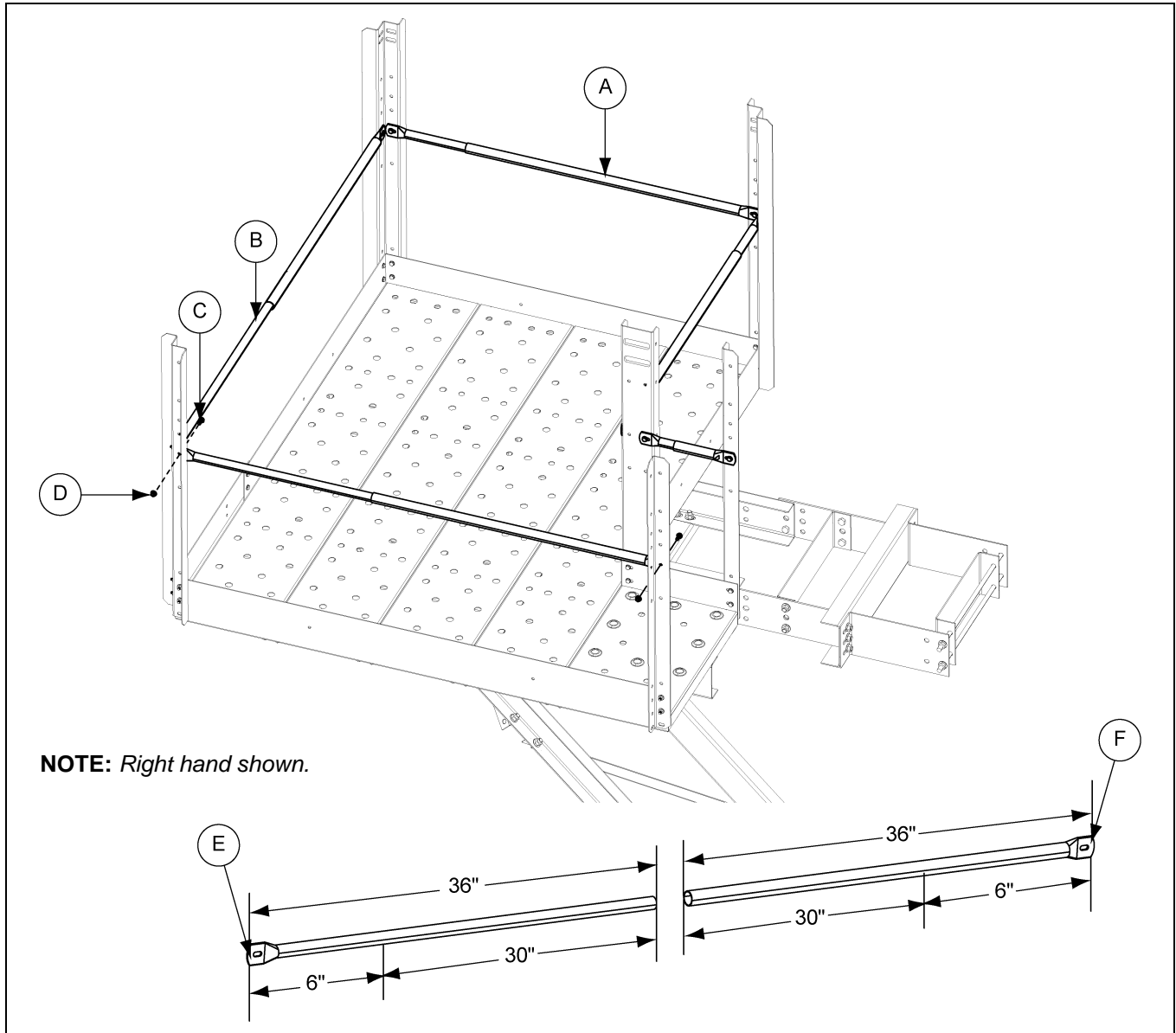

Figure 10M

Ref #	Part #	Description
A	LDR-4087	Large Intermediate Handrail
B	LDR-4088	Small Intermediate Handrail
C	S-6606	5/16" x 3/4" Flange Bolt

Ref #	Part #	Description
D	S-10268	5/16" Flange Nut
E		Cut Small Intermediate Rails
F		Cut Large Intermediate Rails

10. 4 x 5 Distributor Platform (Optional)

Install Safety Bar Cross Supports

NOTE: Safety cage bars (LDR-5171BE) are used as tie braces in this installation.

1. Install safety bar cross supports from the decking toe board to the rail posts using two (2) 5/16" x 3/4" flange bolts and nuts per each cross bar support. (See Figure 10N.)

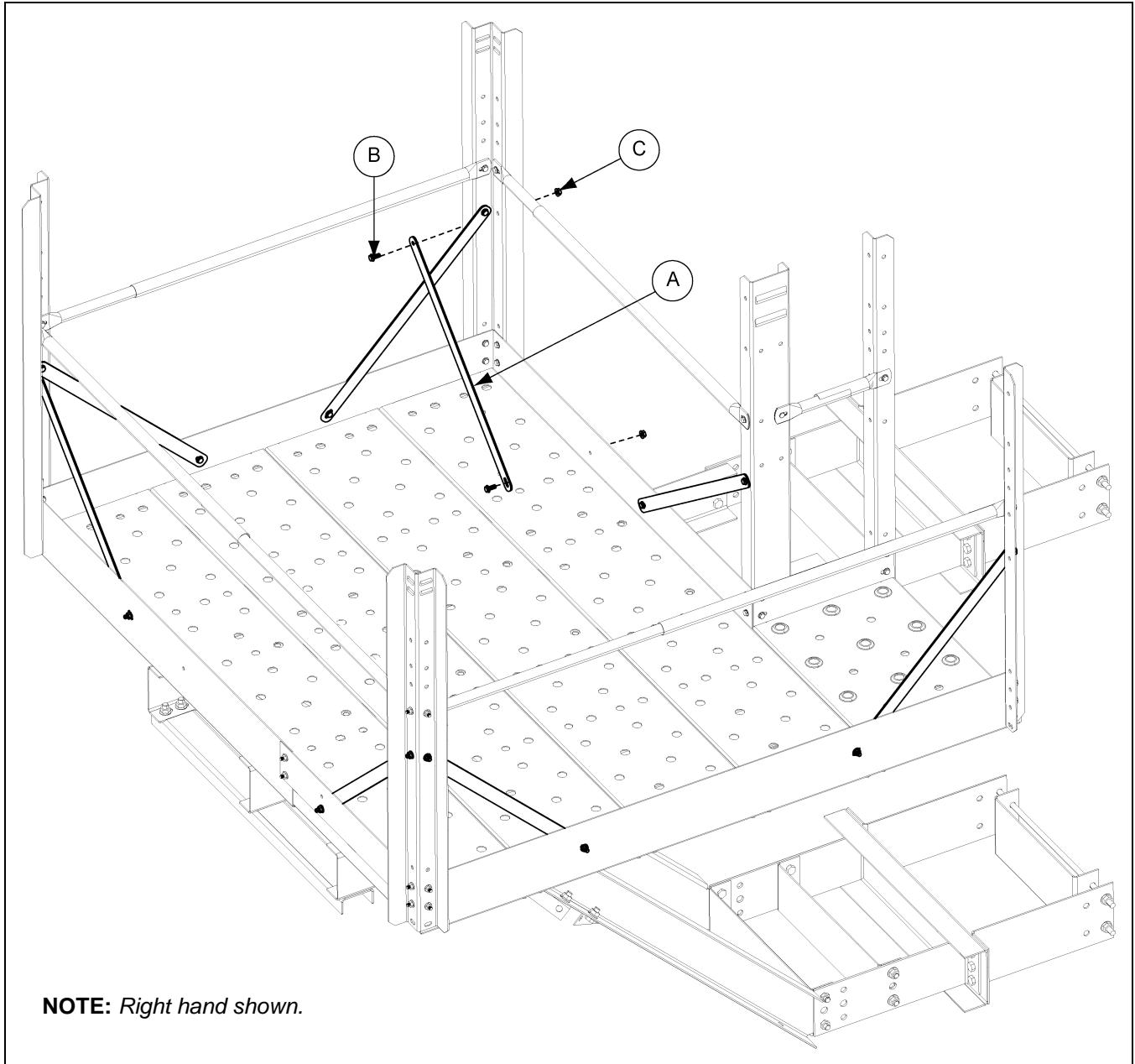

Figure 10N

Ref #	Part #	Description
A	LDR-5171BE	Braces
B	S-6606	5/16" x 3/4" Flange Bolt
C	S-10268	5/16" Flange Nut

Install Top Handrails

1. Attach handrails to the posts using four (4) 5/16" x 3/4" flange bolts and nuts per handrail.
(See Figure 100.)

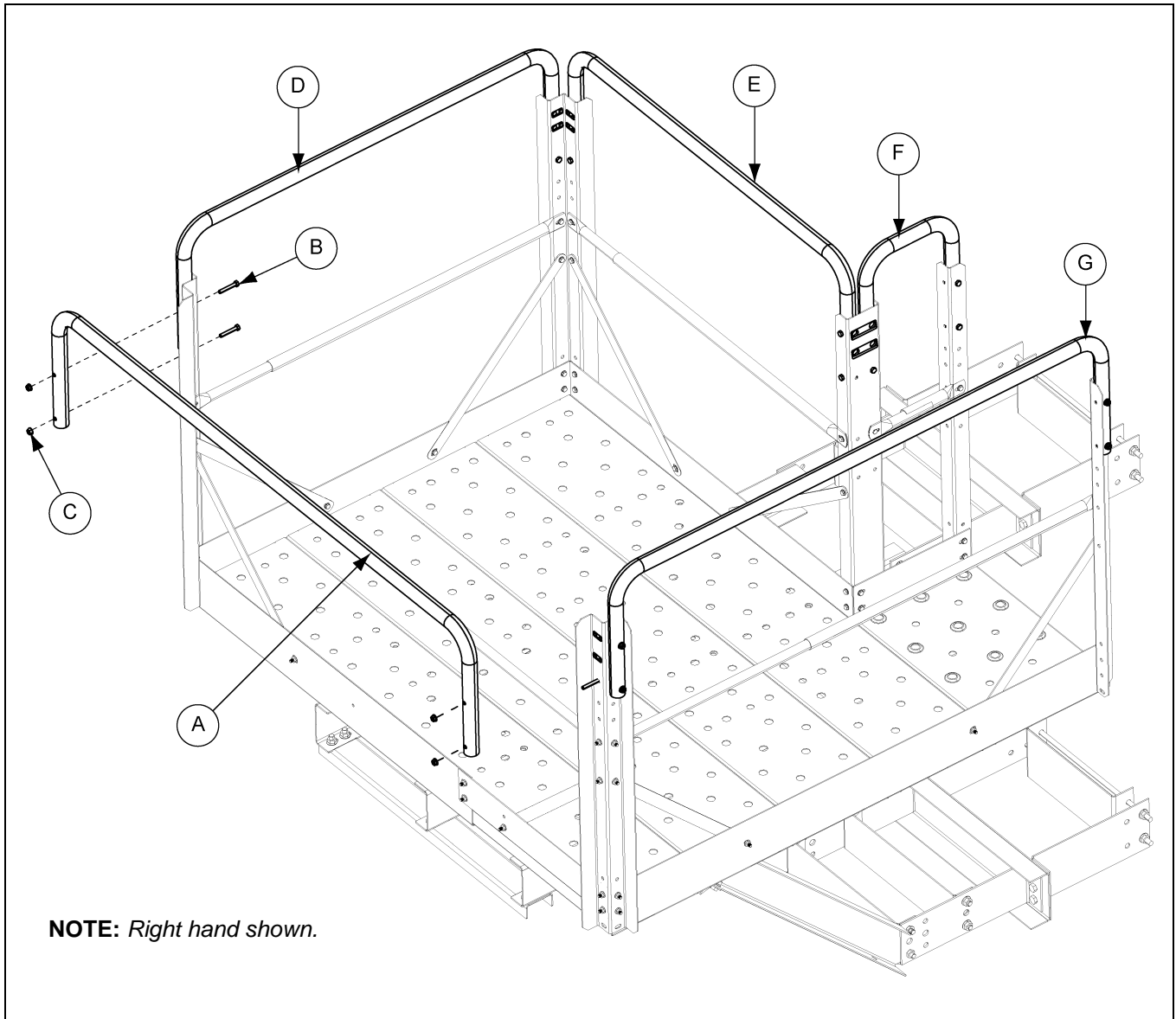

Figure 100

Ref #	Part #	Description
A	HP1648HDH	64.126" Handrail
B	S-7877	5/16" x 2" Bolt
C	S-10268	5/16" Flange Nut
D	DSP1648HIP	45.2" Handrail

Ref #	Part #	Description
E	DSP1648HNT	43.2" Handrail
F	DSP1648HSSG	10.5" Handrail
G	HP1624HFH	59.479" Handrail

10. 4 x 5 Distributor Platform (Optional)

Safety Gate Package (Optional)

IMPORTANT: Attach the platform gate bracket to the gate before attaching it to the inside platform post using 5/16" hardware.

Attach safety gate assembly to intermediate platform door bracket using 5/16" bolt (S-1196), 5/16" flat washer (S-845) and 5/16" flange nut (S-10268).

Attach intermediate platform door bracket to two (2) safety gate side posts (HP1648HP) using 5/16" bolt (S-1196), 5/16" flat washer (S-845) and 5/16" flange nut (S-10268). (See Figure 10P.)

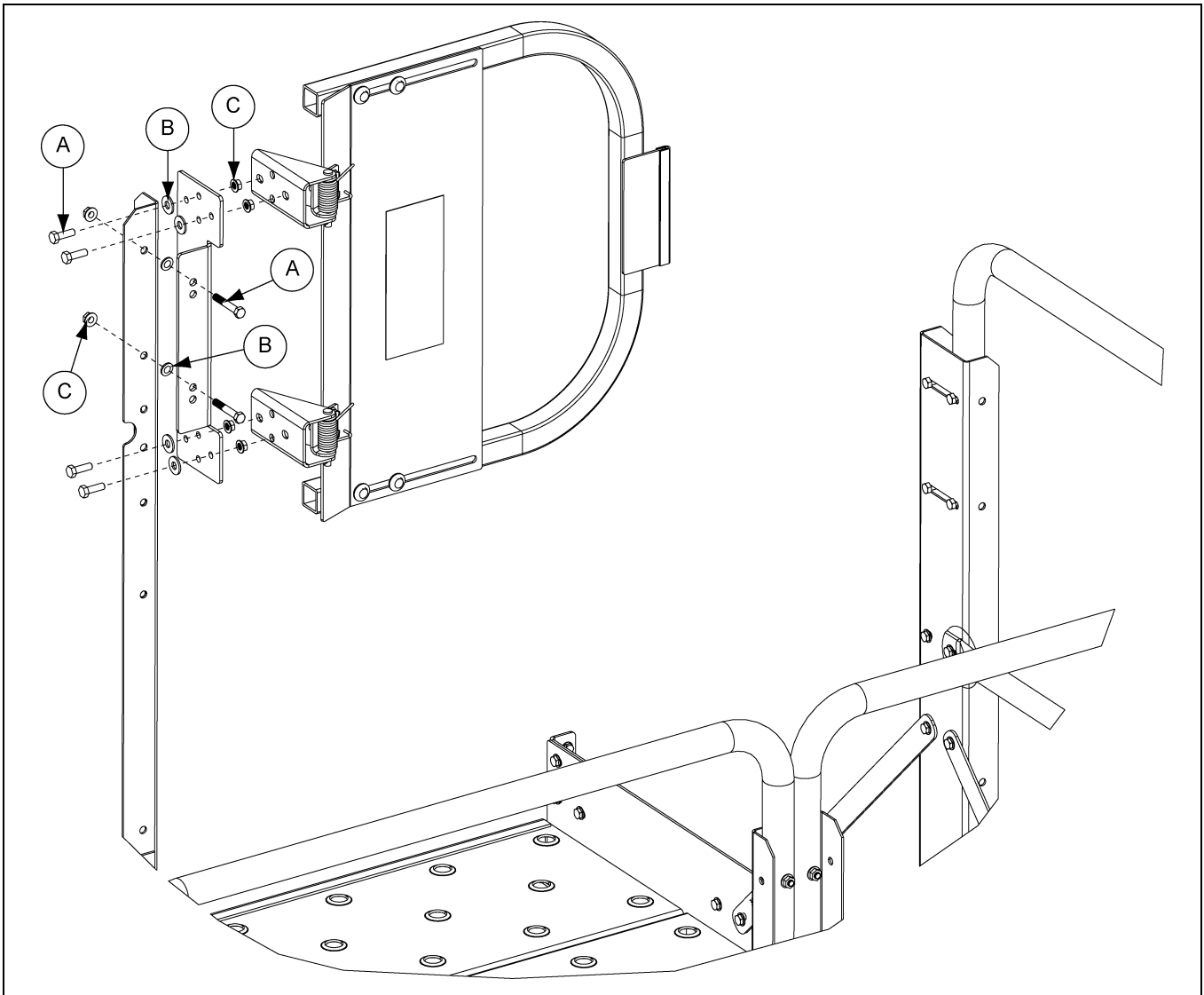

Figure 10P

Ref #	Part #	Description
A	S-1196	5/16" Bolt
B	S-845	5/16" Flat Washer
C	S-10268	5/16" Flange Nut

GSI Group, LLC Limited Warranty

The GSI Group, LLC ("GSI") warrants products which it manufactures to be free of defects in materials and workmanship under normal usage and conditions for a period of 12 months after sale to the original end-user or if a foreign sale, 14 months from arrival at port of discharge, whichever is earlier. The end-user's sole remedy (and GSI's only obligation) is to repair or replace, at GSI's option and expense, products that in GSI's judgment, contain a material defect in materials or workmanship. Expenses incurred by or on behalf of the end-user without prior written authorization from the GSI Warranty Group shall be the sole responsibility of the end-user.

Warranty Extensions:

The Limited Warranty period is extended for the following products:

	Product	Warranty Period	
AP Fans and Flooring	Performer Series Direct Drive Fan Motor	3 Years	* Warranty prorated from list price: 0 to 3 years - no cost to end-user 3 to 5 years - end-user pays 25% 5 to 7 years - end-user pays 50% 7 to 10 years - end-user pays 75%
	All Fiberglass Housings	Lifetime	
	All Fiberglass Propellers	Lifetime	
AP and Cumberland	Flex-Flo/Pan Feeding System Motors	2 Years	
Cumberland Feeding/Watering Systems	Feeder System Pan Assemblies	5 Years **	** Warranty prorated from list price: 0 to 3 years - no cost to end-user 3 to 5 years - end-user pays 50%
	Feed Tubes (1-3/4" and 2.00")	10 Years *	
	Centerless Augers	10 Years *	
	Watering Nipples	10 Years *	
Grain Systems	Grain Bin Structural Design	5 Years	
Grain Systems Farm Fans Zimmerman	Portable and Tower Dryers	2 Years	† Motors, burner components and moving parts not included. Portable dryer screens included. Tower dryer screens not included.
	Portable and Tower Dryer Frames and Internal Infrastructure †	5 Years	

GSI further warrants that the portable and tower dryer frame and basket, excluding all auger and auger drive components, shall be free from defects in materials for a period of time beginning on the twelfth (12th) month from the date of purchase and continuing until the sixtieth (60th) month from the date of purchase (extended warranty period). During the extended warranty period, GSI will replace the frame or basket components that prove to be defective under normal conditions of use without charge, excluding the labor, transportation, and/or shipping costs incurred in the performance of this extended warranty.

Conditions and Limitations:

THERE ARE NO WARRANTIES THAT EXTEND BEYOND THE LIMITED WARRANTY DESCRIPTION SET FORTH ABOVE. SPECIFICALLY, GSI MAKES NO FURTHER WARRANTY OF ANY KIND, EXPRESS OR IMPLIED, INCLUDING, WITHOUT LIMITATION, WARRANTIES OF MERCHANTABILITY OR FITNESS FOR A PARTICULAR PURPOSE OR USE IN CONNECTION WITH: (I) PRODUCT MANUFACTURED OR SOLD BY GSI OR (II) ANY ADVICE, INSTRUCTION, RECOMMENDATION OR SUGGESTION PROVIDED BY AN AGENT, REPRESENTATIVE OR EMPLOYEE OF GSI REGARDING OR RELATED TO THE CONFIGURATION, INSTALLATION, LAYOUT, SUITABILITY FOR A PARTICULAR PURPOSE, OR DESIGN OF SUCH PRODUCTS.

GSI shall not be liable for any direct, indirect, incidental or consequential damages, including, without limitation, loss of anticipated profits or benefits. The sole and exclusive remedy is set forth in the Limited Warranty, which shall not exceed the amount paid for the product purchased. This warranty is not transferable and applies only to the original end-user. GSI shall have no obligation or responsibility for any representations or warranties made by or on behalf of any dealer, agent or distributor.

GSI assumes no responsibility for claims resulting from construction defects or unauthorized modifications to products which it manufactured. Modifications to products not specifically delineated in the manual accompanying the equipment at initial sale will void the Limited Warranty.

This Limited Warranty shall not extend to products or parts which have been damaged by negligent use, misuse, alteration, accident or which have been improperly/inadequately maintained. This Limited Warranty extends solely to products manufactured by GSI.

Prior to installation, the end-user has the responsibility to comply with federal, state and local codes which apply to the location and installation of products manufactured or sold by GSI.

This equipment shall be installed in accordance with the current installation codes and applicable regulations, which should be carefully followed in all cases. Authorities having jurisdiction should be consulted before installations are made.

G S I G R O U P



GSI Group
1004 E. Illinois St.
Assumption, IL 62510-0020
Phone: 1-217-226-4421
Fax: 1-217-226-4420
www.gsiag.com



GSI is a worldwide brand of AGCO Corporation.