

CE Compliant 30"-36" Bucket Elevator Platform and Ladder "X" Series

Installation Manual

PNEG-1849CE

Version: 2.0

Date: 06-20-16



PNEG-1849CE

Use of the equipment information page will help you identify the equipment in the case that you need to call your dealer or installer. This information should be filled out and kept on record.

Equipment Information

Model #: _____

Serial #: _____

Date Purchased: _____

Dealer/Distributor Name and Phone #: _____

Material Handling

1004 E. Illinois St.
Assumption, IL. 62510
Phone: 1-217-226-4421

All information, illustrations, photos and specifications in this manual are based on the latest information available at the time of publication. The right is reserved to make changes at any time without notice.

Contents

Chapter 1 Introduction	5
Chapter 2 Safety	6
Safety Guidelines	6
Cautionary Symbols Definitions	7
Safety Cautions	8
Safety Sign-Off Sheet	12
Chapter 3 Decal Location	13
Chapter 4 Overview	14
Chapter 5 Ladder Assembly	15
Ladder and Platform Layout for European CE Compliance	15
Chapter 6 Tie Angles, Ladders and Safety Cages	22
Attach Tie Angle to Boot Trunking	22
Attach Boot Ladder Support Brackets and Boot Ladder Section	24
Install Boot Ladder Section	26
Tie Angles to Trunking	28
Ladder Support Brackets	30
Attach Ladders to Ladder Brackets	32
Safety Cage Installation	33
Install Safety Cage	34
Chapter 7 Rest Platform	37
Rest Platform Tie Angles to Bucket Elevators	37
Attach Rest Platform Channel to the Rest Platform Tie Angle	40
Rest Platform Cross Channel to Rest Platform Mounting Channels	41
Ladder Support	49
Chapter 8 30"-36" Head Platform Right Hand Drive	50
Attach Cross Deck Support Channels to Lower Head	51
For 30" Right Side Drive	52
For 36" Right Side Drive	54
Attach Deck A to Hatch Cover Plate	56
Slide/Place Toe Boards on Cross Deck Support Channels	57
Connect Deck A to Cross Deck Support Channels and Toe Board	58
Connect Deck C to Cross Deck Support Channel and to Toe Board	60
Connect Deck F to Cross Deck Support Channels and Deck C	62
Attach Third Cross Deck Support Channel to Decking	64
Attach Deck E to Deck A, Deck C and Cross Deck Support Channel	64
Chapter 9 30"-36" Head Platform Left Hand Drive	66
Attach Cross Deck Support Channels to Lower Head	67
For 30" Left Side Drive	68
For 36" Left Side Drive	70
Attach Deck A to Hatch Cover Plate	72
Slide/Place Toe Boards on Cross Deck Support Channels	73
Connect Deck A to Cross Deck Support Channels and Toe Board	74
Connect Deck C to Cross Deck Support Channel and to Toe Board	75
Connect Deck F to Cross Deck Support Channels and Deck C	77
Attach Third Cross Deck Support Channel to Decking	79
Attach Deck E to Deck A, Deck C and Cross Deck Support Channel	79

Table of Contents

Chapter 10 30"-36" Head Platform Post, Rails and Bracing	81
Attach Head Bearing Support Angle to Lower Head for 30"	81
Attach Head Bearing Support Angle to Lower Head for 36"	82
Attach Handrail Supports to Deck E	83
Install Posts	84
Install Head Side Posts	85
Attach Intermediate Handrails to Posts	88
Install Upper Handrails	90
Install Safety Cage Bar Cross Supports	92
Chapter 11 Install Hatch	93
Chapter 12 4 x 5 Distributor Platform (Optional)	97
Install Clamp Band	97
Assemble Supports	99
Assemble Decking	101
Install Handrail Posts - Non Entrance Side	105
Assemble and Install Intermediate Handrails	106
Install Safety Bar Cross Supports	107
Install Upper Handrails	108
Safety Gate Package (Optional)	109
Chapter 13 6 x 6 Distributor Platforms	110
Platform Clamps	110
Support Channels and Knee Braces	111
Toe Boards	112
Cross Braces for Knee Braces	113
Platform Decking	115
Platform Post	117
Tie Braces	118
Intermediate Handrail	119
Upper Handrails	120
Safety Gate Package (If Ordered as Optional)	124
Chapter 14 Warranty	127

Chapter 1: Introduction

READ THIS MANUAL carefully to learn how to properly use and install equipment. Failure to do so could result in personal injury or equipment damage.

INSPECT the shipment immediately upon arrival. The customer is responsible for ensuring that all quantities are correct. The customer should report and note any damage or shortage on the bill of lading to justify their claim to the transport company.

THIS MANUAL SHOULD BE CONSIDERED a permanent part of your equipment and should be easily accessible when needed.

This warranty provides you the assurance that the company will back its products when defects appear within the warranty period. In some circumstances, the company also provides field improvements, often without charge to the customer, even if the product is out of warranty. Should the equipment be abused, or modified to change its performance beyond the factory specifications, the warranty will become void and field improvements may be denied.

Chapter 2: Safety

Safety Guidelines

Safety guidelines are general-to-specific safety rules that must be followed at all times. This manual is written to help you understand safe operating procedures and problems that can be encountered by the operator and other personnel when using this equipment. Save these safety guidelines for future reference.

As owner or operator, you are responsible for understanding the requirements, hazards, and precautions that exist and to inform others as required. Unqualified persons must stay out of the work area at all times.

Alterations must not be made to the equipment. Alterations can produce dangerous situations resulting in **SERIOUS INJURY** or **DEATH**.

This equipment must be installed in accordance with the current installation codes and applicable regulations, which must be carefully followed in all cases. Authorities having jurisdiction must be consulted before installations are made.

When necessary, you must consider the installation location relative to electrical, fuel and water utilities.

Personnel operating or working around equipment must read this manual. This manual must be delivered with equipment to its owner. Failure to read this manual and its safety instructions is a misuse of the equipment.

ST-0001-3

Cautionary Symbols Definitions

Cautionary symbols appear in this manual and on product decals. The symbols alert the user of potential safety hazards, prohibited activities and mandatory actions. To help you recognize this information, we use the symbols that are defined below.



This symbol indicates an imminently hazardous situation which, if not avoided, **will result in serious injury or death.**



This symbol indicates a potentially hazardous situation which, if not avoided, **can result in serious injury or death.**



This symbol indicates a potentially hazardous situation which, if not avoided, **can result in minor or moderate injury.**



This symbol is used to address practices not related to personal injury.



This symbol indicates a general hazard.



This symbol indicates a prohibited activity.

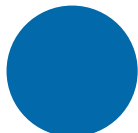

This symbol indicates a mandatory action.

ST-0005-2

Safety Cautions

Use Personal Protective Equipment

- Use appropriate personal protective equipment:

Eye Protection



Respiratory Protection



Foot Protection



Hearing Protection



Head Protection



Fall Protection



Hand Protection



- Wear clothing appropriate to the job.
- Remove all jewelry.
- Tie long hair up and back.

ST-0004-1

Follow Safety Instructions

- Carefully read all safety messages in this manual and safety signs on your machine. Keep signs in good condition. Replace missing or damaged safety signs. Be sure new equipment components and repair parts include the current safety signs. Replacement safety signs are available from the manufacturer.
- Learn how to operate the machine and how to use controls properly. Do not let anyone operate without instruction.
- If you do not understand any part of this manual or need assistance, contact your dealer.



ST-0002-1

Maintain Equipment and Work Area

- Understand service procedures before doing work. Keep area clean and dry.
- Never service equipment while it is operating. Keep hands, feet, and clothing away from moving parts.
- Keep your equipment in proper working condition. Replace worn or broken parts immediately.



ST-0003-1

Install and Operate Electrical Equipment Properly

- Electrical controls must be installed by a qualified electrician and must meet the standards set by applicable local codes (National Electric Code for the US, Canadian Electric Code, or EN60204 along with applicable European Directives for Europe).
- Lock-out power source before making adjustments, cleaning, or maintaining equipment.
- Make sure all equipment and bins are properly grounded.



ST-0027-3

Sharp Edge Hazard

- This product has sharp edges, which can cause serious injury.
- To avoid injury, handle sharp edges with caution and always use proper protective clothing and equipment.



ST-0036-2

Fall Hazard

- Keep access door closed while on a platform to avoid falls.
- Always use proper personal protective equipment and proper clothing when using equipment. Failure to follow safety precautions can result in severe injury or death.



ST-0042-2

2. Safety

Toxic Fume and Dust Hazard

- Remove paint before welding or heating.
- Avoid potentially toxic fumes and dust. Hazardous fumes can be generated when paint is heated by welding, soldering, or using a torch.
- Do all work outside or in a well-ventilated area. Dispose of paint and solvent properly.
- Remove paint before welding or heating:
 - If you sand or grind paint, avoid breathing the dust. Wear an approved respirator.
 - If you use solvent or paint-stripper, remove stripper with soap and water before welding.
 - Remove solvent or stripper containers and other flammable material from area. Allow fumes to disperse at least 15 minutes before welding or heating.



ST-0043-1

Platform Load Limit

- The platform load limit is 500 LBS (2.25 kN). Do not exceed this weight.
- Excessive load will damage the platform and cause platform to fall. Severe injury or death will result.



ST-0044-2

Stay Clear of Hoisted Equipment

- Always use proper lifting or hoisting equipment when assembling or disassembling equipment.
- Do not walk or stand under hoisted equipment.
- Always use sturdy and stable supports when needed for installation. Not following these safety precautions creates the risk of falling equipment, which can crush personnel and cause serious injury or death.



ST-0047-1

Fall Hazard

- Ladders, stairways and platforms are for use by competent and trained personnel only. Do not allow children or other unauthorized persons to have access to the equipment.
- Access to the equipment must be restricted by the use of security fencing and lockable gates.
- Lower sections of ladders must be fitted with a lockable safety gate to prevent unauthorized access.
- Make sure that hot surfaces have had adequate time to cool before working on or in the equipment.
- Lock out and tag out power supplies and fuel supplies to all equipment.
- Do not attach lifting equipment to ladders or platforms.
- Do not go outside of the safety rails provided on elevated platforms.
- Do not work at heights during high winds, rain, snow, or ice storms.



ST-0056-1

Chapter 3: Decal Location

DANGER



**DO NOT EXCEED
PLATFORM LOAD LIMIT**

Load limit = 500 LBS. (2.25 kN)

Excessive load will damage platform and cause platform to fall.

Injury or death will result.

DC-2146



WARNING



FALL HAZARD

- Fall hazard present when hatch door open.
- Fall may result in serious injury or death
- Close hatch door while on platform.

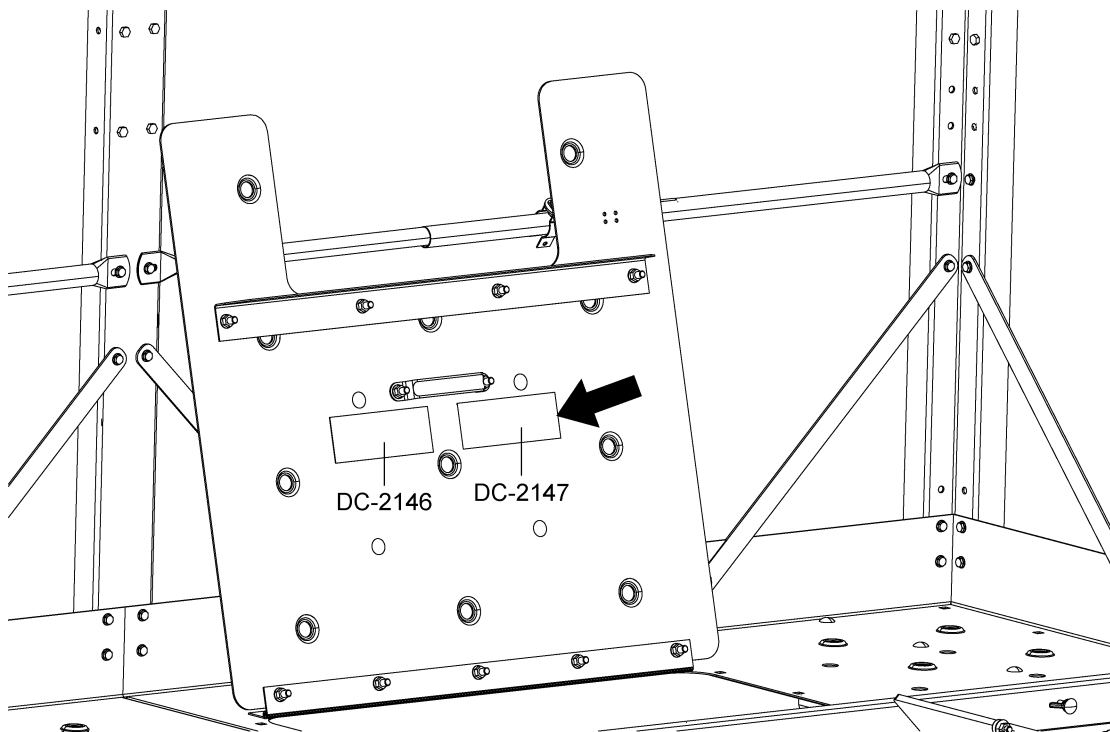
DC-2147



Chapter 4: Overview

This section is intended to provide a general, high-level overview of platform assembly for the GSI bucket elevator. Detailed instructions are given in the pages to come.

This section should be used for reference only and is intended to provide general guidance about the overall process only.

1. Support Channels:

Proper orientation of channels is based upon the size of the bucket elevator (16", 24", 30" or 36") and the right/left hand position of the drive. This must be installed correctly at the start or nothing else will install correctly.

2. Ladders and Safety Cages:

Ladder sections mount directly to the trunking sections of the bucket elevator. Typical ladder layouts and charts identifying the support height for ladder packages can be found [on Pages 15 through 20](#).

3. Tie Angles to Trunking:

- Proper orientation of the tie angles is critical for correct installation.
- Note differences from up-leg and down-leg installations.

Be sure to follow the instructions for the size and drive position.

Throughout this manual, particular attention is given to the initial orientation of channels and aligning bolt holes. Failure to complete these initial steps correctly will significantly impede the assembly and installation of the bucket elevator platforms.

4. Decking and Toe Boards:

Decking is etched with alpha characters to assist with orienting decks and aligning holes for connections. Decking connections should be finger-tight only initially so that adjustments can be made once all decks and toe boards are in place. Only then should all hardware be fully torqued.

5. Handrail Platform Posts:

The number and location of platform posts varies based upon platform and bucket elevator size.

6. Handrails:

Intermediate handrails (those at near knee level) may need to be field cut to fit. The amount to trim varies based upon the size of the platform being installed. The smaller rail then fits inside of the larger rail so that it "telescopes" between the posts. Always follow best practices of "measure twice, cut once" and verify the measurement is for the bucket elevator size. Upper handrails do not require any alterations in the field prior to assembly.

7. Platform Braces:

Throughout this manual, safety cage bars (LDR-517BE) are used as platform braces. These are required for support and stability. Please attach as described through the manual.

Chapter 5: Ladder Assembly

The ladder sections are to be mounted directly to the trunking sections. Quantities and section lengths may vary depending on overall height of system. If you have a non-standard height system, refer to supported bucket height reference chart for the correct ladder package for the system.

NOTE: Ladders are of a modular design for ease of modification in the field. These illustrations are only to be used as a "general" guide to installation layout. The exact assembly may vary due to the unique nature of each bucket elevator.

Ladder and Platform Layout for European CE Compliance

To comply with European Directives for CE marking, the maximum rest platform spacing is reduced, in accordance with EN ISO14122-4:2004. Please follow the recommended layouts given below.

(See Figures 5A-5G on Pages 15-21.)

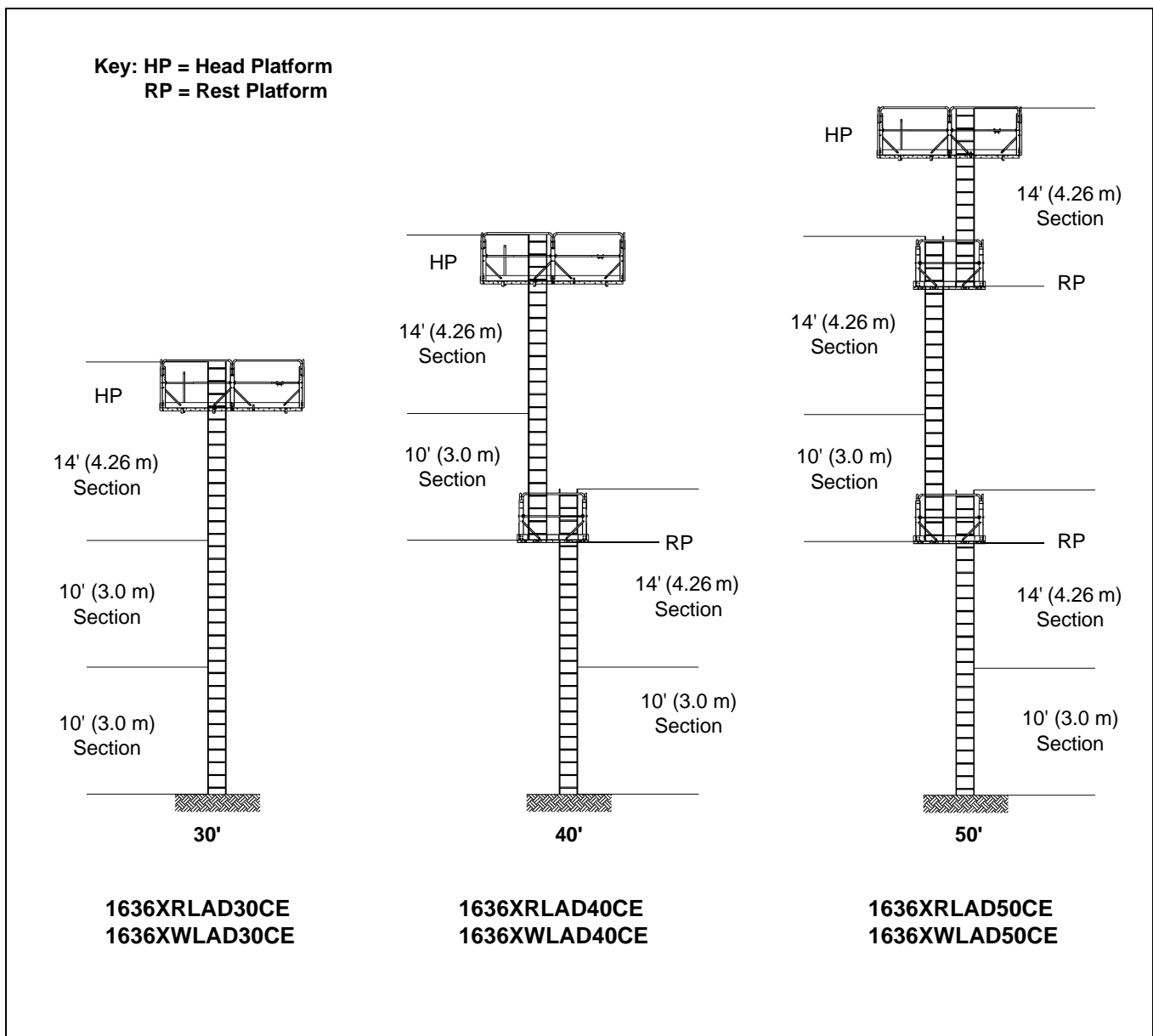

Figure 5A

5. Ladder Assembly

Key: HP = Head Platform
 RP = Rest Platform

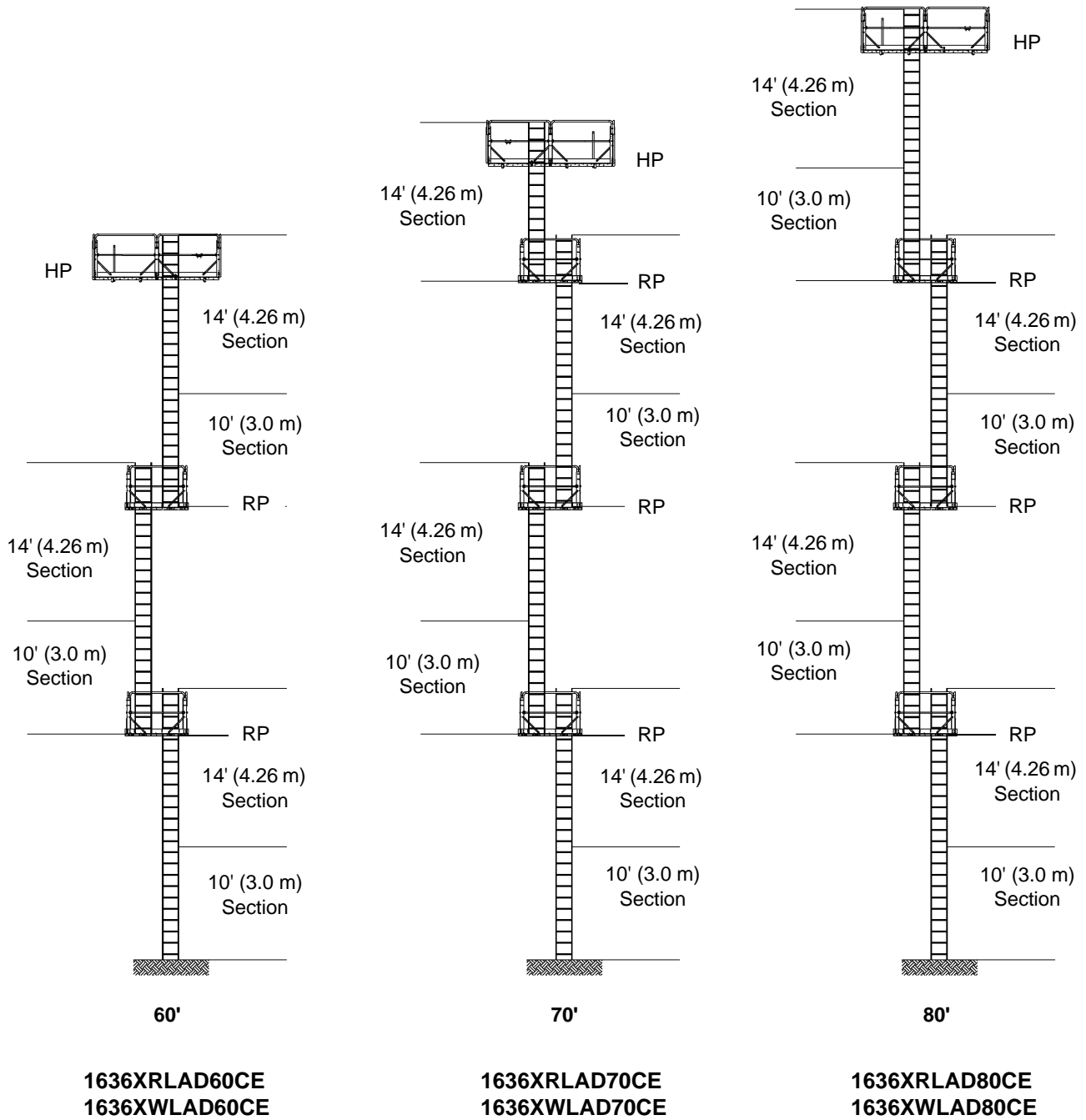

Figure 5B

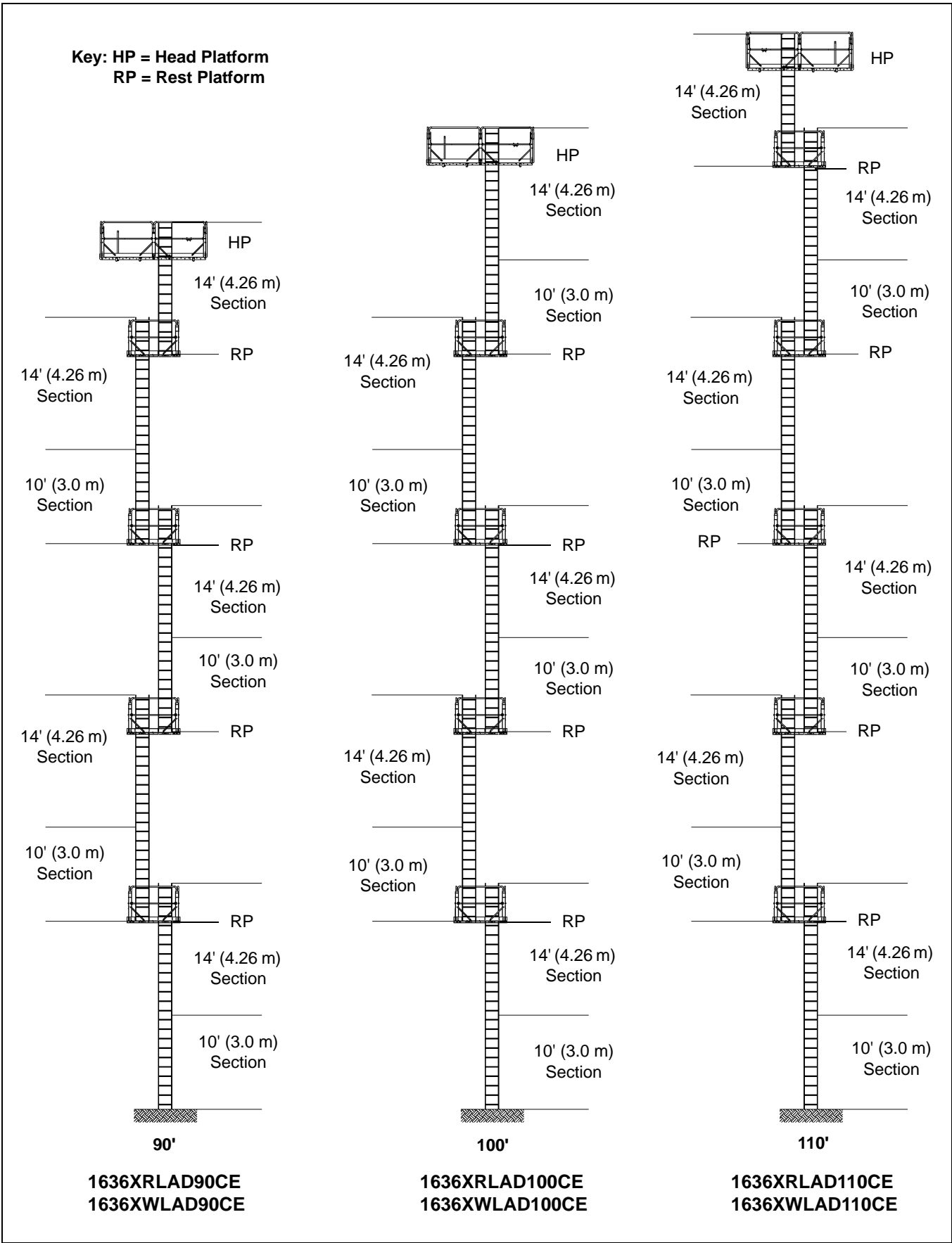

Figure 5C

5. Ladder Assembly

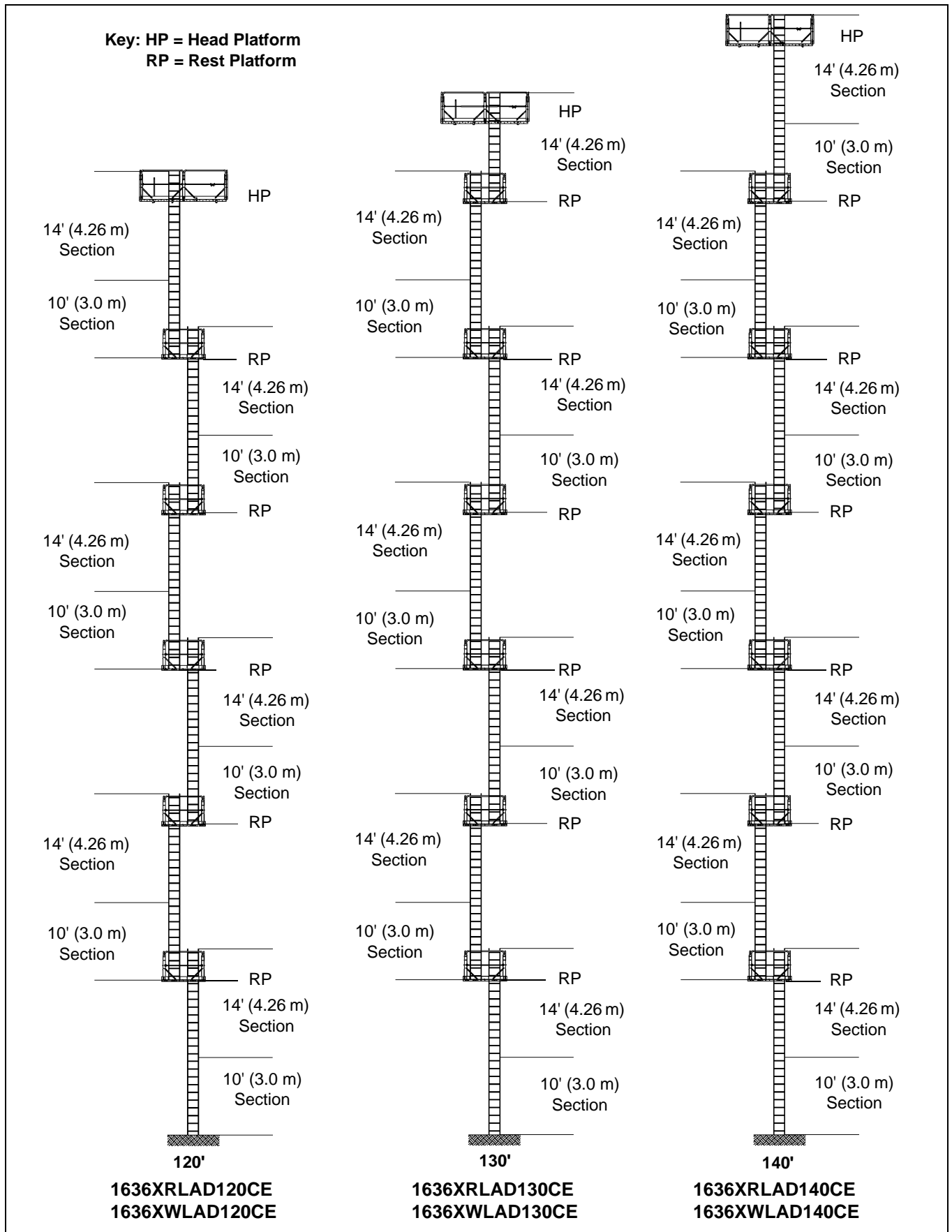

Figure 5D

Key: HP = Head Platform
RP = Rest Platform

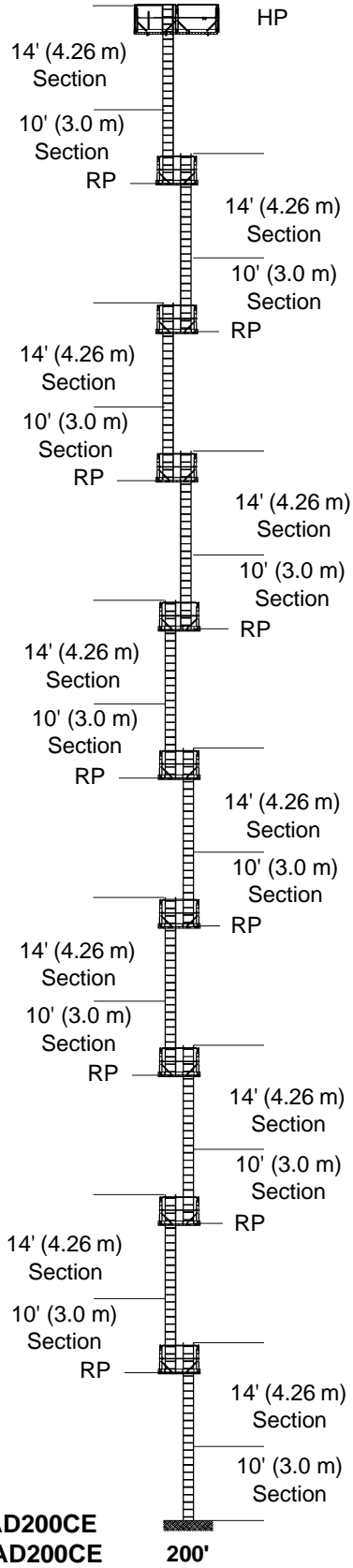
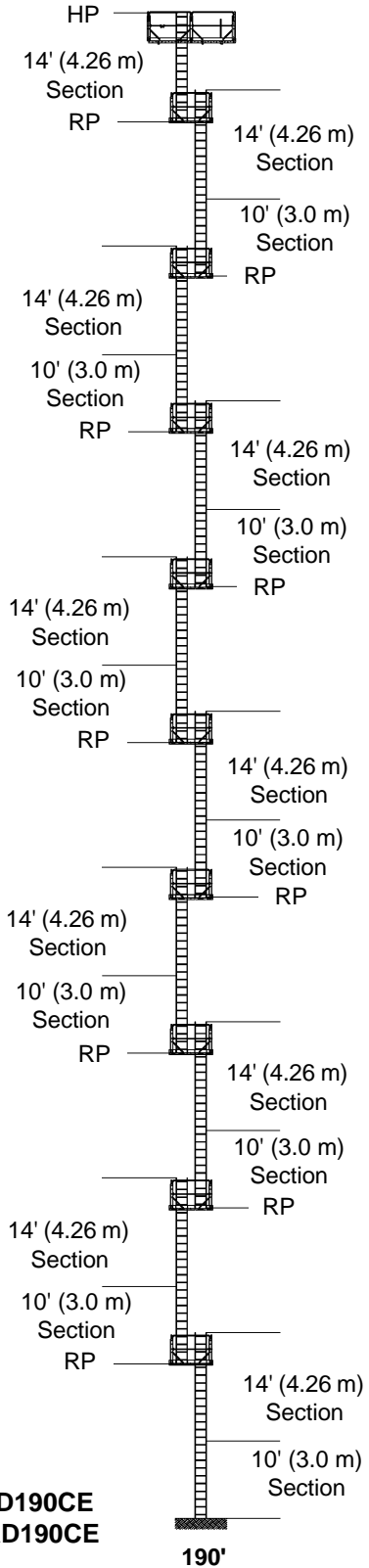

Figure 5G

Chapter 6: Tie Angles, Ladders and Safety Cages

Attach Tie Angle to Boot Trunking

1. On the NON LADDER SIDE, attach tie angle to the trunking using 1/2" x 1" bolts (S-7935) (B).
(See Figure 6A below and Figure 6B on Page 23.)
 - a. **For 30" Boot Tie Angle:** With lip of tie angle up and outward, align tie angle so that it extends beyond the trunking at each end. *(See Figure 6A.)*

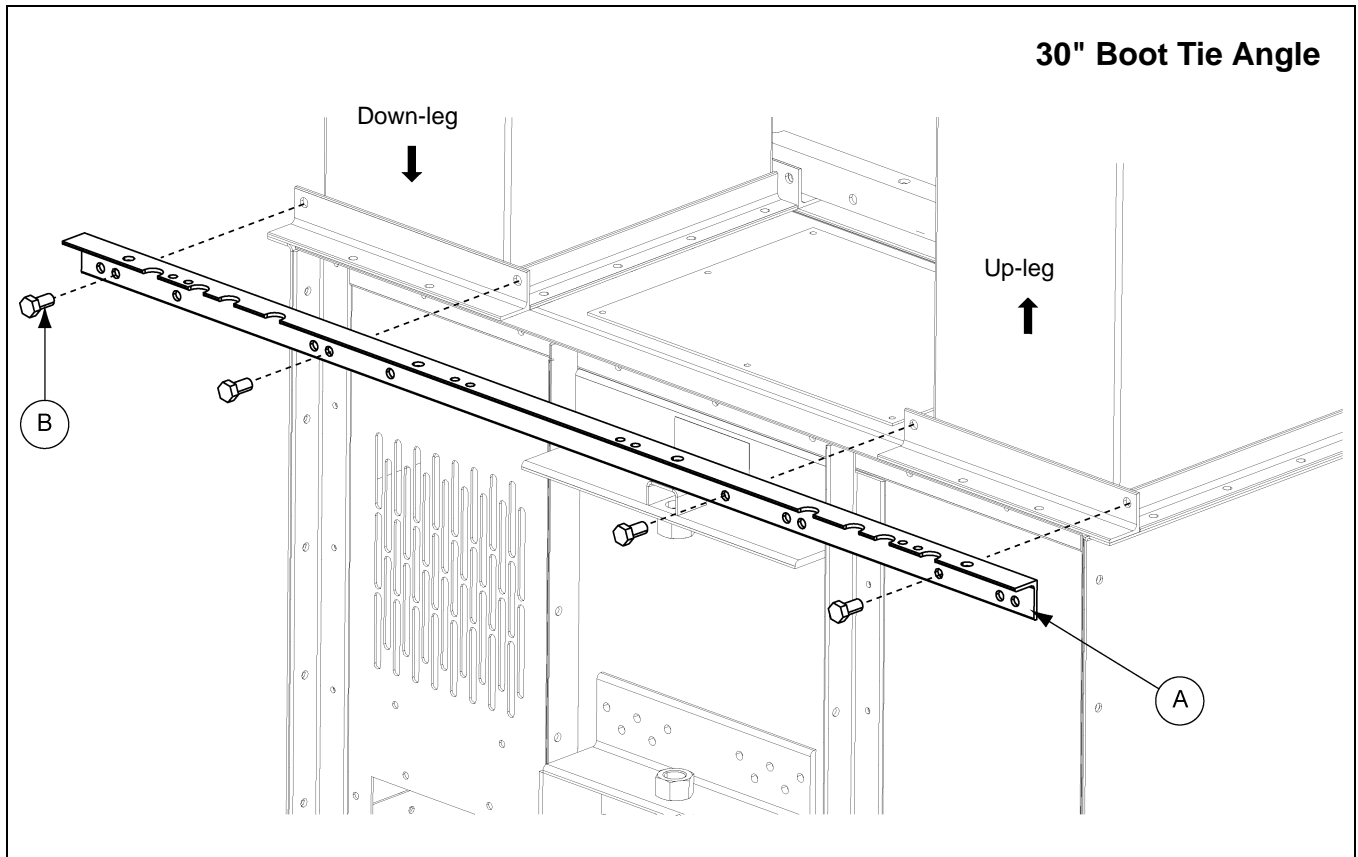

Figure 6A 30" Boot Tie Angle

Ref #	Part #	Description
A	GECT3040FX	30"-36" Type "X" Tie Angle
A	BECT3040X	
B	S-7935	1/2" x 1" Bolt

Attach Tie Angle to Boot Trunking (Continued)

b. **For 36" Boot Tie Angle:** With lip of tie angle up and outward, align both edges of tie angle to edges of trunking. Note the tie angle will not extend beyond the trunking. (See Figure 6B.)

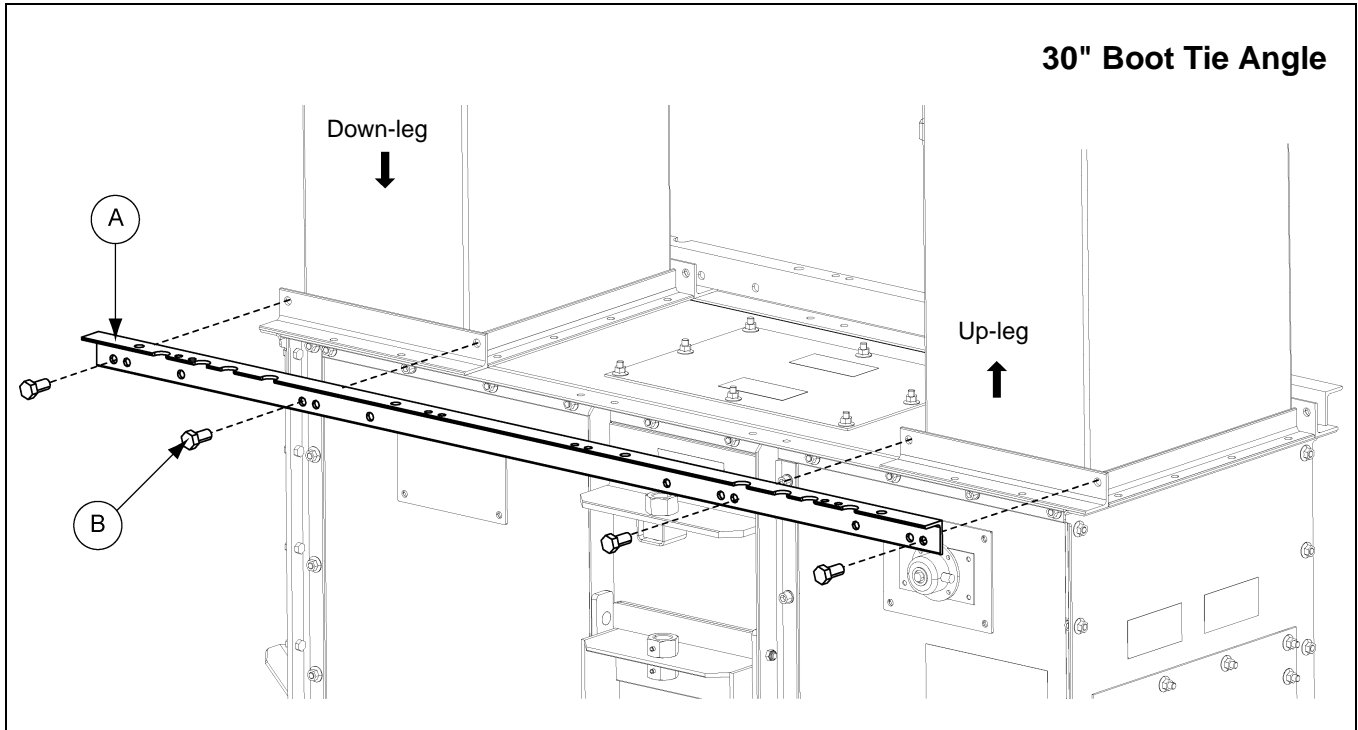

Figure 6B 36" Boot Tie Angle

Ref #	Part #	Description
A	GECT3040FX	30"-36" Type "X" Tie Angle
A	BECT3040X	
B	S-7935	1/2" x 1" Bolt

6. Tie Angles, Ladders and Safety Cages

Attach Boot Ladder Support Brackets and Boot Ladder Section

NOTE: Refer to ladder layout images, [Figure 5A-5F on Pages 15-20](#).

NOTE: Ladders can be mounted to either the up-leg or down-leg end of the elevator depending on the height and head platform hatch location.

NOTE: Both up-leg and down-leg bracket locations are shown in this manual, however, only one will actually be installed based on owner preference and layout of the elevator.

Depending on the height and head platform hatch location. Ladder can be mounted to either the up-leg or the down-leg side, refer to ladder layout [Figure 5A-5F on Pages 15-20](#). **NOTE:** Both up-leg and down-leg bracket locations are shown, but only one side will be used.

1. Use the holes indicated based on bucket elevator size in [Figure 6C](#) and attach ladder support brackets to boot tie angle using 3/8" x 1" hex bolts (S-7469) (A). Remember to double check if the ladder should start on the up-leg side or the down-leg side. ([See Figure 6C below and Figure 6D on Page 25.](#))
 - a. **30"-36" Down-Leg Bracket:** Use 3/8" x 1" hex bolts (S-7469) (A) to attach the ladder support brackets to the boot tie angle using the holes indicated in [Figure 6C](#). Note the outer bracket uses the first set of holes on the outside.

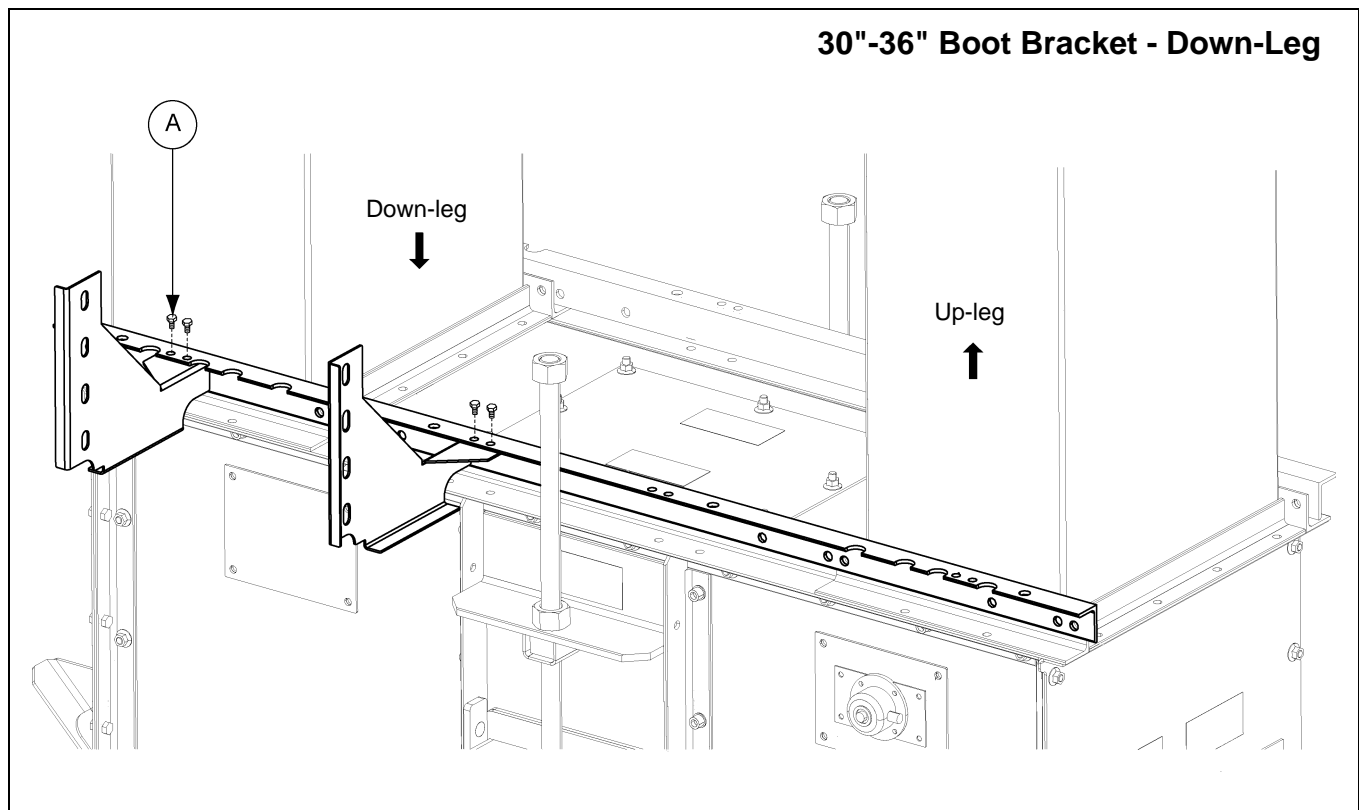

Figure 6C 30\"-36\" Boot Bracket Down-Leg

Ref #	Part #	Description
A	S-7469	3/8" x 1" Hex Bolt

Attach Boot Ladder Support Brackets and Boot Ladder Section (Continued)

- b. **30"-36" Up-Leg Bracket:** Use 3/8" x 1" hex bolts (S-7469) (A) to attach the ladder support brackets to the boot tie angle using the holes indicated in *Figure 6D*. Note the outer bracket uses the first set of holes towards the outside.

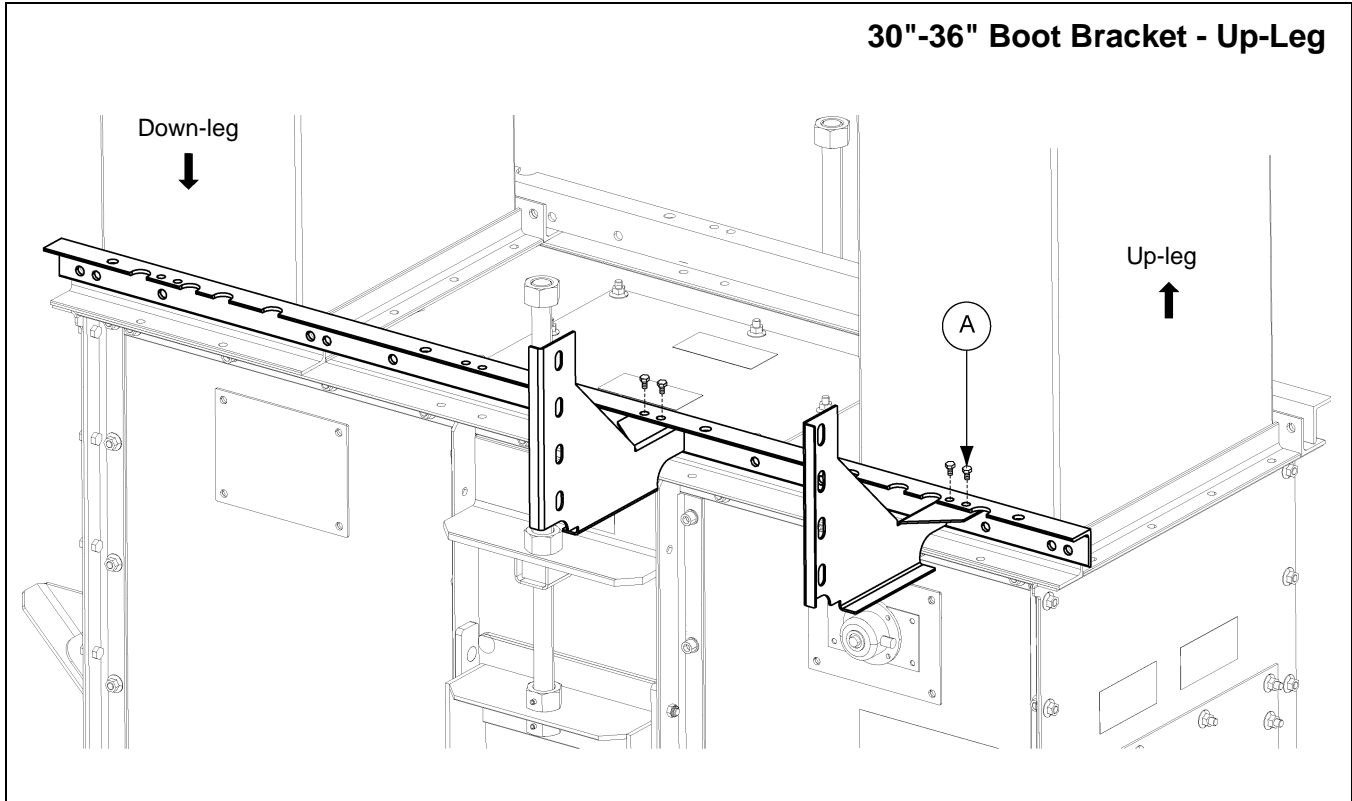

Figure 6D 30"-36" Boot Bracket Up-Leg

Ref #	Part #	Description
A	S-7469	3/8" x 1" Hex Bolt

Install Boot Ladder Section

1. Trim a 10' ladder section to sit so that the first ladder rung is 12" from the ground. (See Figure 6E.)

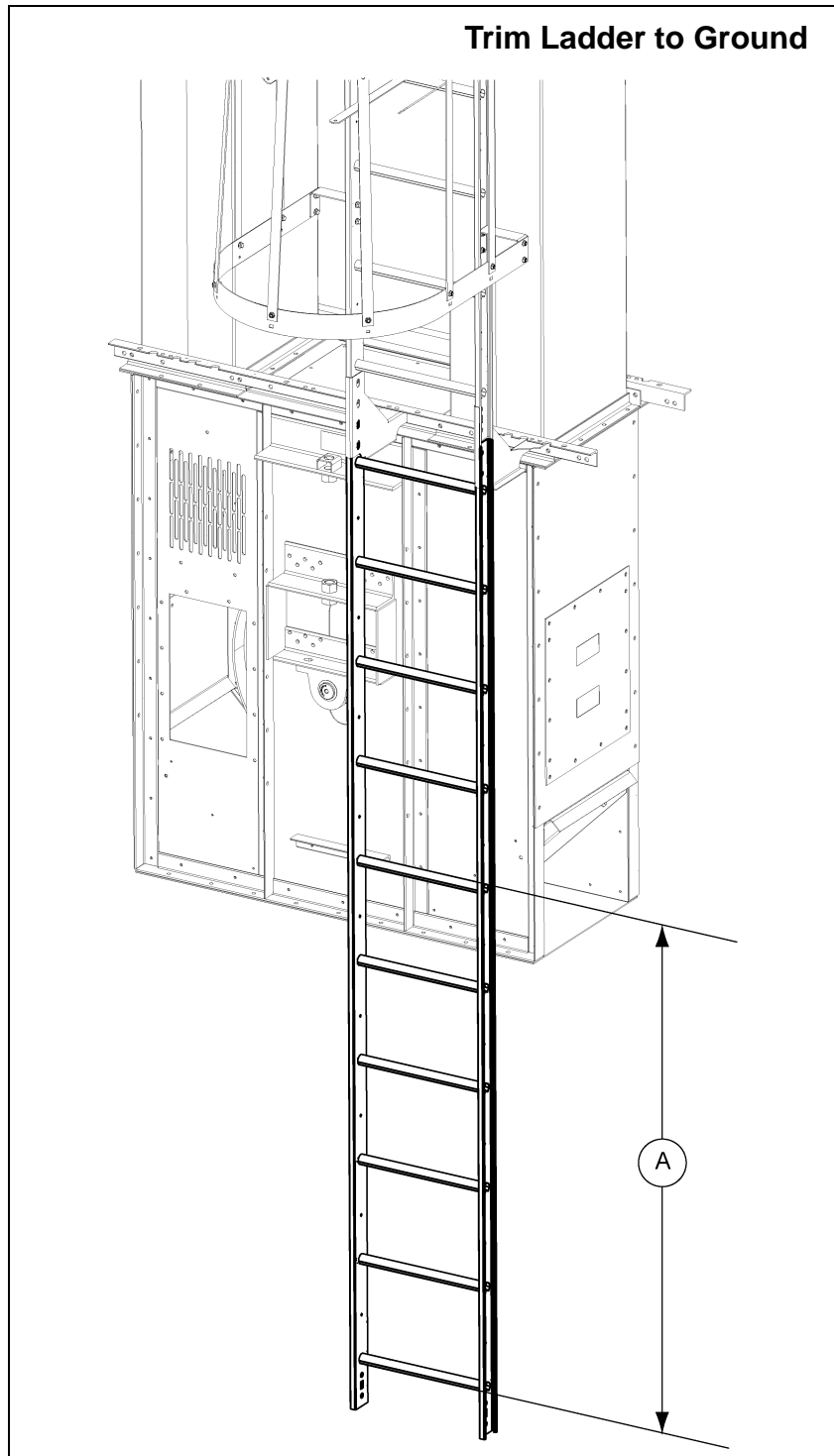

Figure 6E

Ref #	Description
A	Cut this section of the ladder so bottom rung of the ladder is 12" from the ground.

Install Boot Ladder Section (Continued)

2. Attach trimmed ladder section to the left and right ladder brackets using 1/2" x 1" hex bolts (S-7935) (D) through the bottom most set of holes.
3. Attach the next ladder section to the ladder brackets using 1/2" x 1" hex bolts (S-7935) (D) through the top set of holes. (See Figure 6F.)

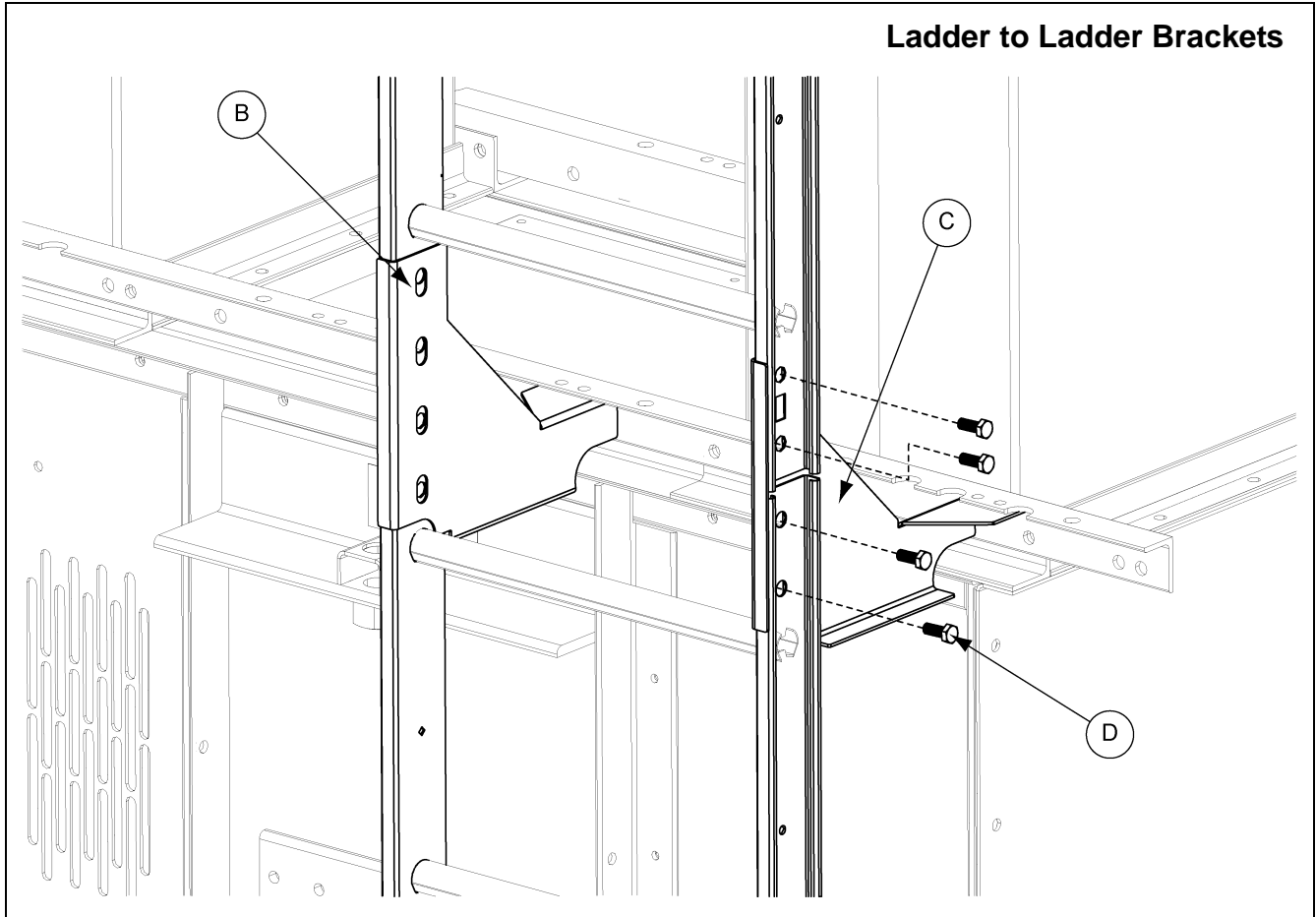

Figure 6F

Ref #	Part #	Description
B	LAD1648TLH	Trunk Support Bracket L.H. Side
C	LAD1648TRH	Trunk Support Bracket R.H. Side
D	S-7935	1/2" x 1" Hex Bolt

4. Secure the bottom of the ladder to the boot or ground. **NOTE:** Bracket for this step is not included.

6. Tie Angles, Ladders and Safety Cages

Tie Angles to Trunking

1. Tie angles must be mounted to each trunking seam on both the ladder and non-ladder side of the trunking. Use 1/2" x 1" bolts (S-7935) (B). *See Figures 6G-6I on Pages 28 and 29* for the correct location of bolts for each elevator size.

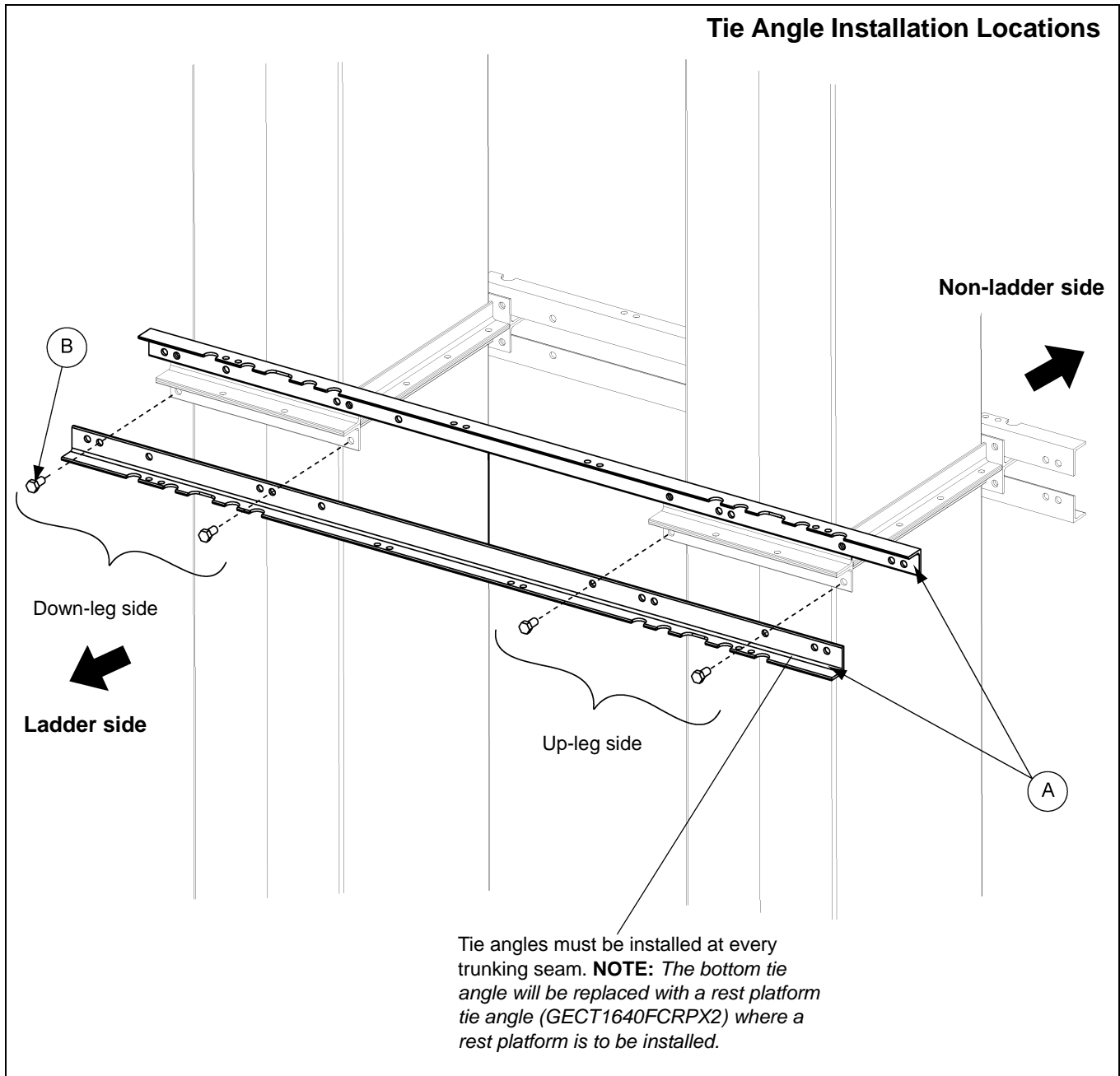

Figure 6G Tie Angle Installation Location

Ref #	Part #	Description
A	BECT3040X	30"-36" Type "X" Trunking Tie Angle
A	GECT3040FX	
B	S-7935	1/2" x 1" Bolt

Tie Angles to Trunking (Continued)

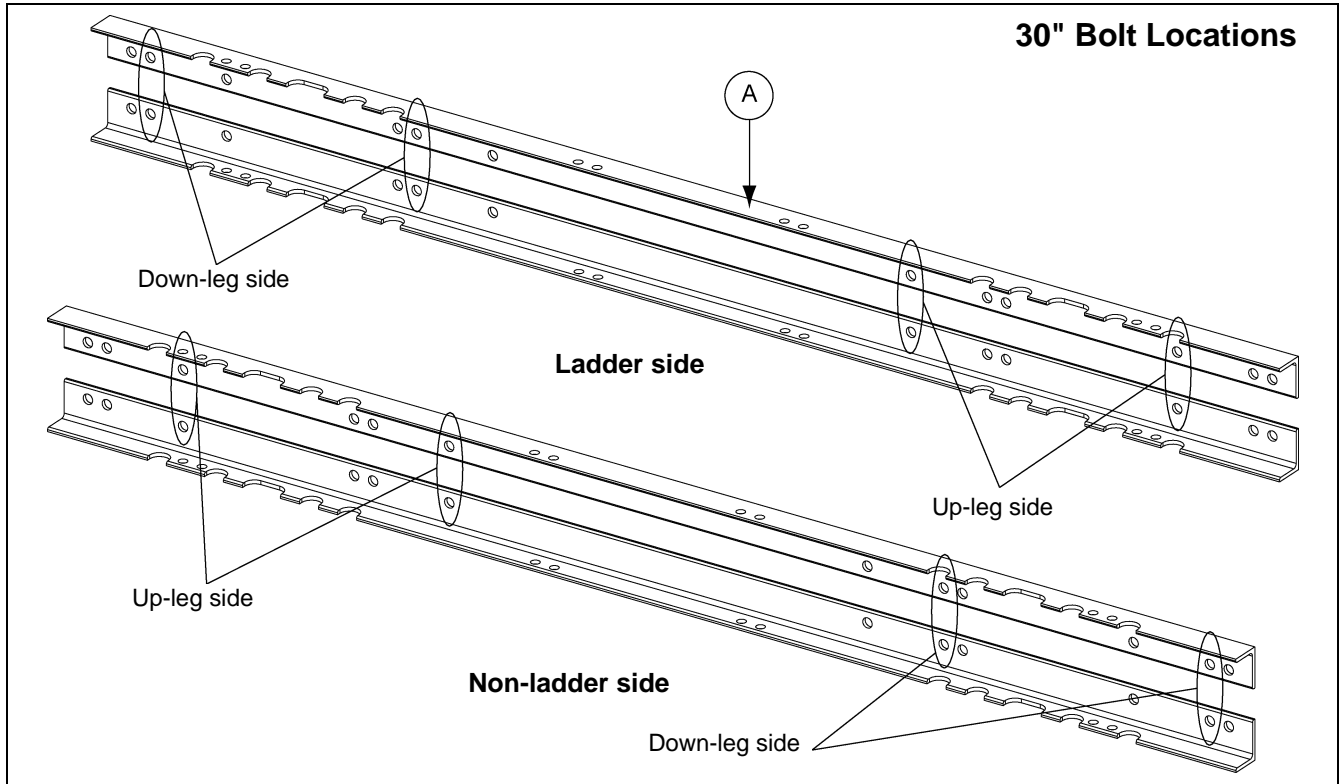

Figure 6H 30" Bucket Elevator Tie Angles to Trunking Bolt Locations

Ref #	Part #	Description
A	BECT3040X	30" Type "X" Trunking Tie Angle
A	GECT3040FX	

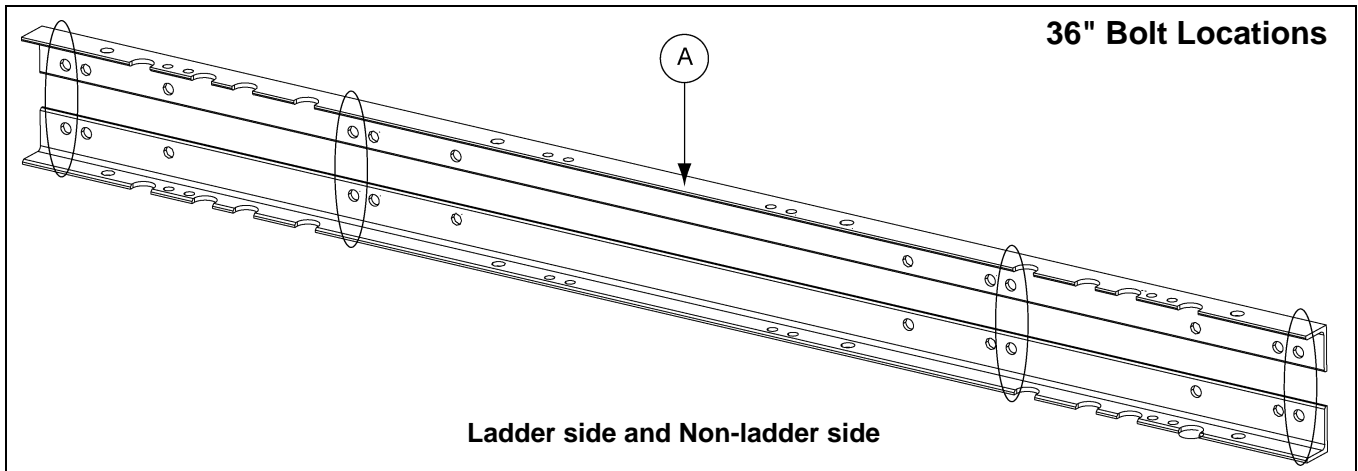

Figure 6I 36" Bucket Elevator Tie Angles to Trunking Bolt Locations

Ref #	Part #	Description
A	BECT3040X	36" Type "X" Trunking Tie Angle
A	GECT3040FX	

6. Tie Angles, Ladders and Safety Cages

Ladder Support Brackets

1. Attach ladder support brackets to tie angle using 3/8" x 1" hex bolts (S-7469) (G). Use the holes shown in [Figure 6J](#) for each size elevator.
2. Mount the upper right and upper left hand ladder support brackets (B and D) to the top tie angle (E) with 3/8" bolts.
3. Mount the lower right hand and lower left hand ladder support brackets (A and C) to the bottom tie angle (E) with 3/8" bolts. ([See Figure 6J.](#))
4. Secure the flanges of the ladder brackets together with 3/8" x 1" hex bolts (S-7469) (G).

NOTE: You will only use one set of ladder brackets, either the up-leg set or the down-leg set.

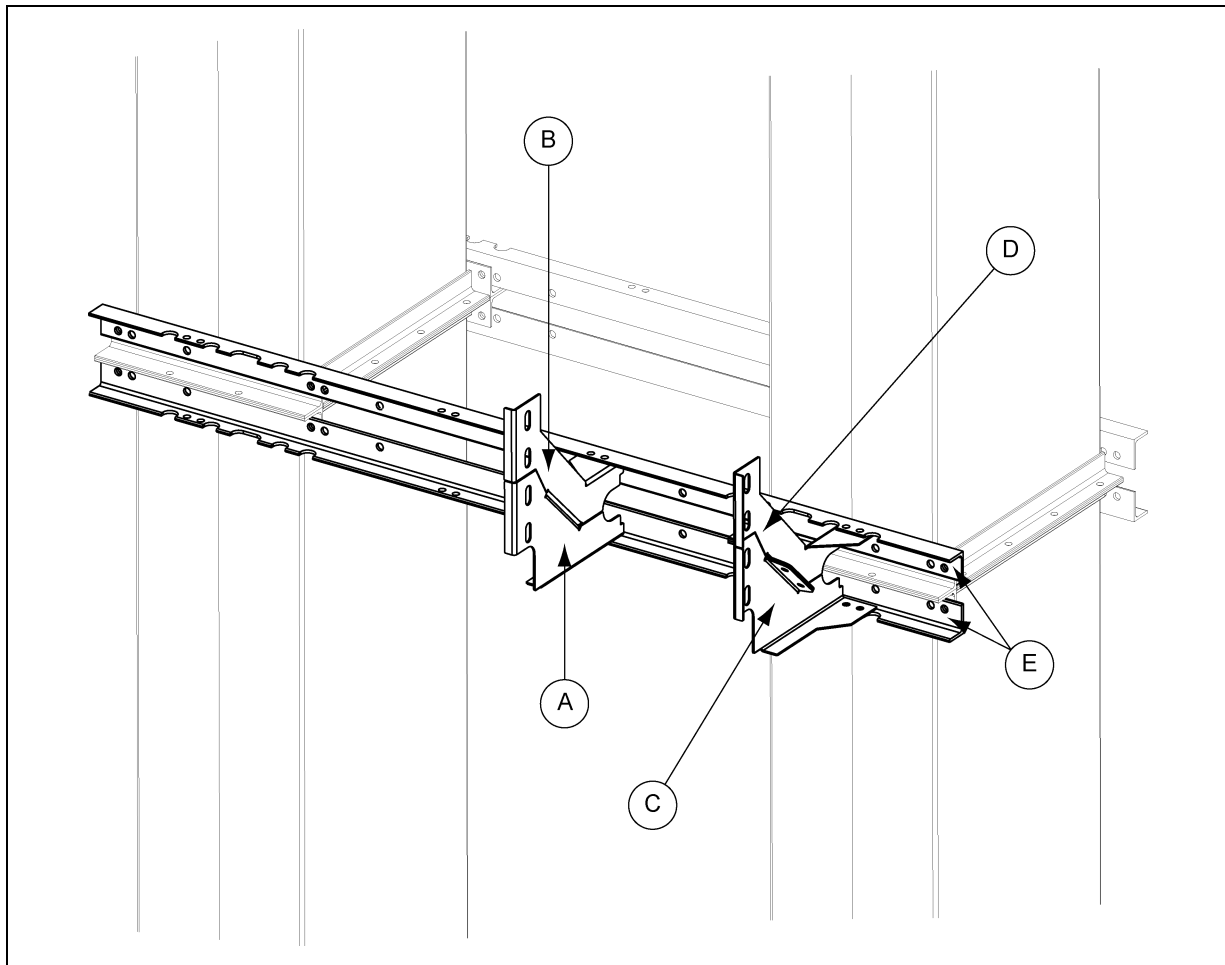

Figure 6J Ladder Support Bracket Parts

Ref #	Part #	Description
A	LAD1648TLH1	Lower Left Hand Ladder Support Bracket
B	LAD1648TLH2	Upper Left Hand Ladder Support Bracket
C	LAD1648TRH1	Lower Right Hand Ladder Support Bracket
D	LAD1648TRH2	Upper Right Hand Ladder Support Bracket
E		Tie Angles

Ladder Support Brackets (Continued)

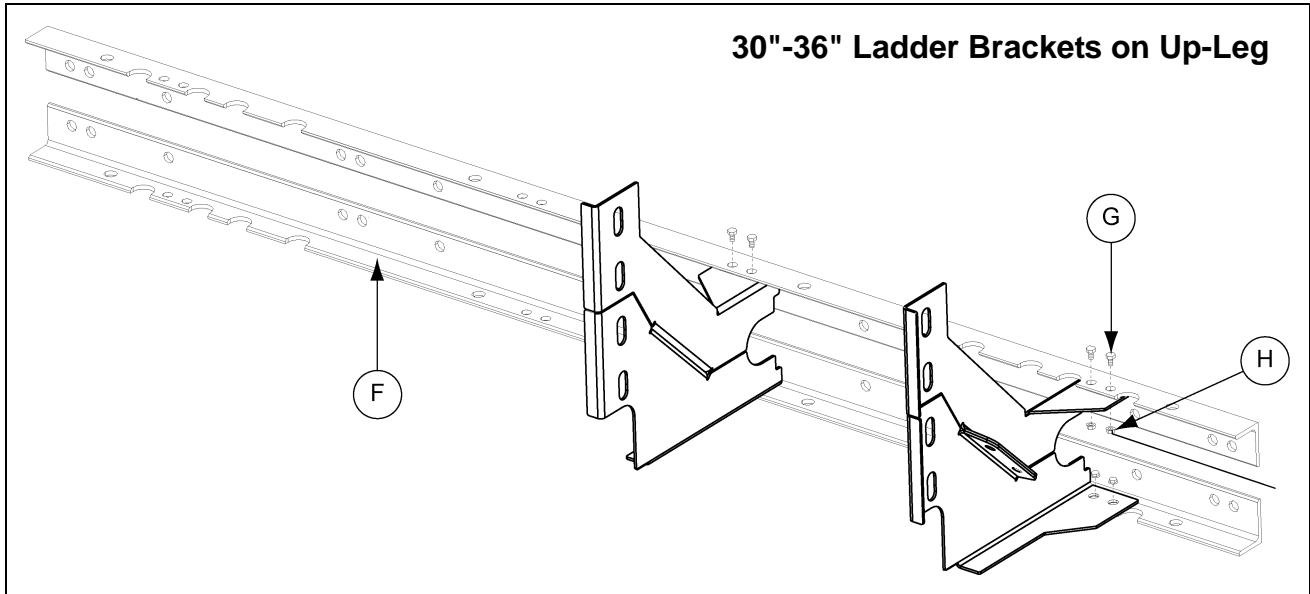

Figure 6K 30"-36" Ladder Bracket Location for Up-Leg

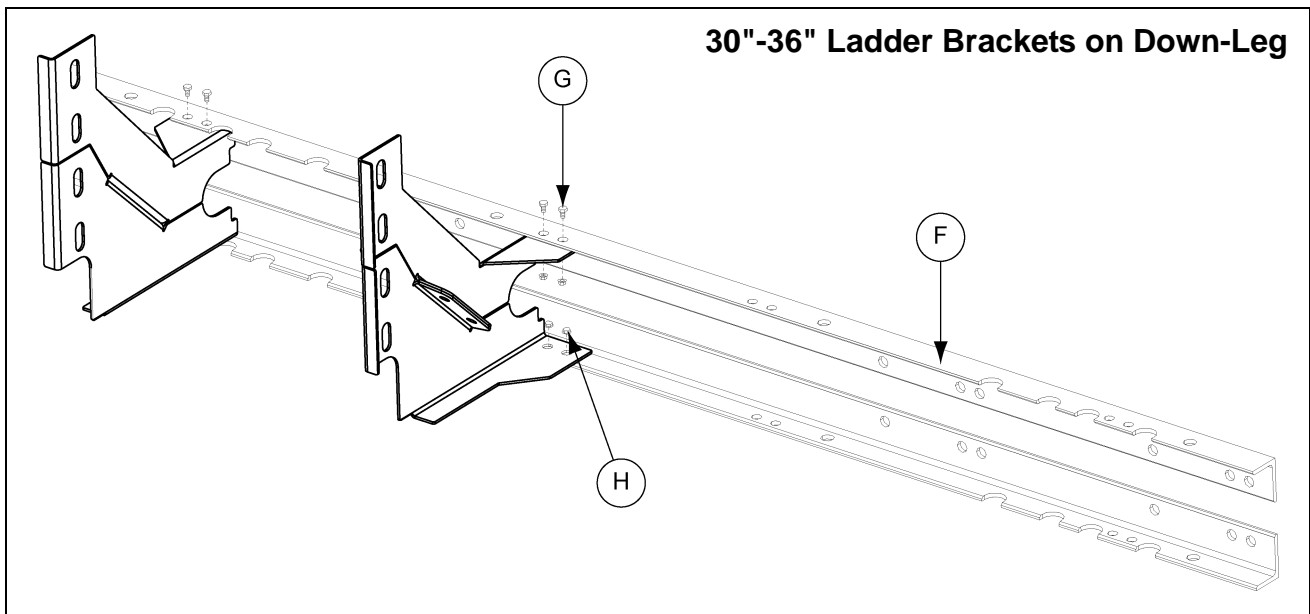

Figure 6L 30"-36" Ladder Bracket Location for Down-Leg

Ref #	Part #	Description
F	BECT3040X	30"-36" Type "X" Trunking Tie Angle
F	GECT3040FX	
G	S-7469	3/8" x 1" Bolt
H	S-968	3/8" Flange Nut

6. Tie Angles, Ladders and Safety Cages

Attach Ladders to Ladder Brackets

1. Attach ladder sections to the ladder brackets using 1/2" x 1" hex bolts (S-7935) (F). (See Figure 6M.)

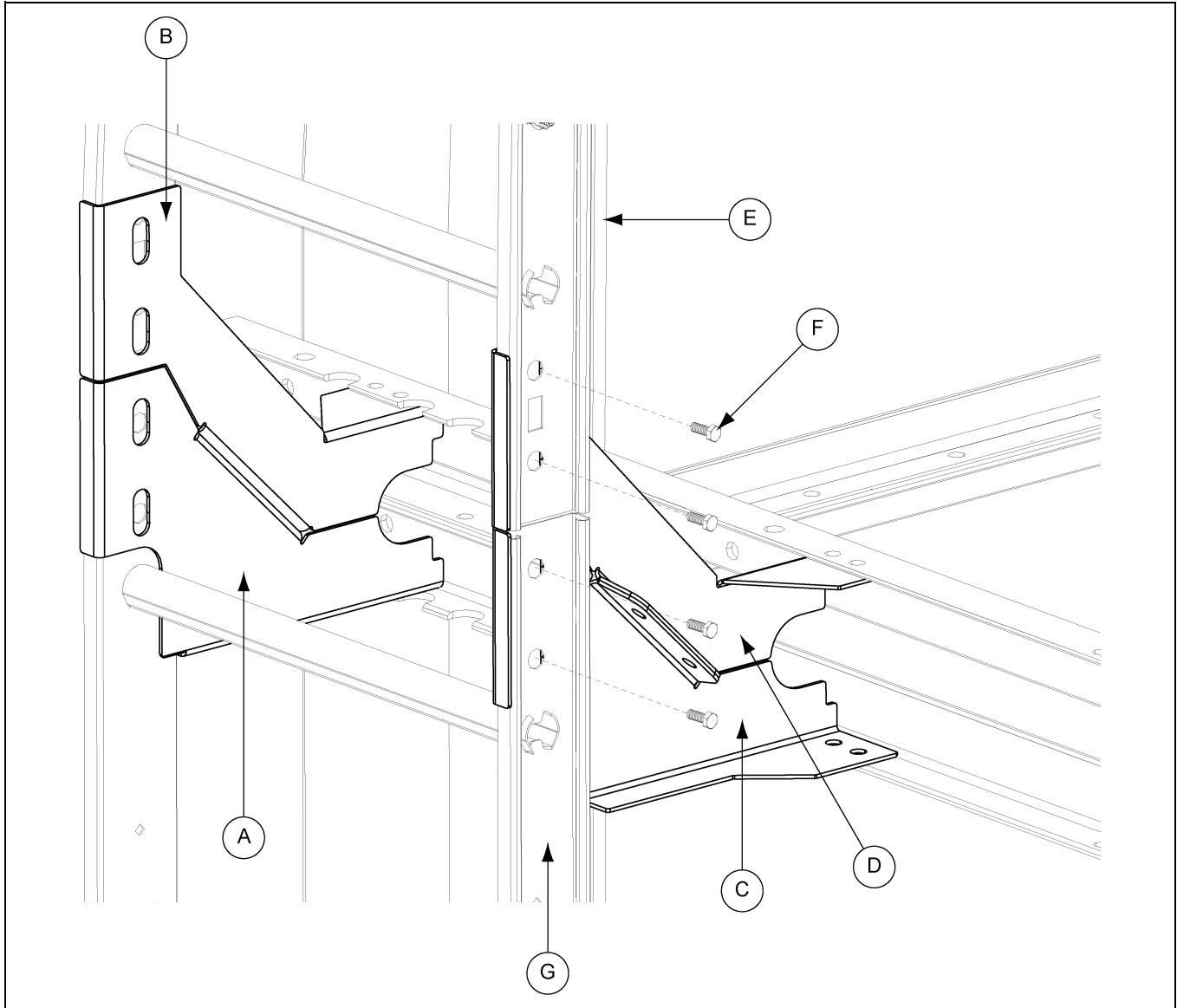

Figure 6M

Ref #	Part #	Description
A	LAD1648TLH1	Bottom Trunk Support Bracket L.H. Side
B	LAD1648TLH2	Top Trunk Support Bracket L.H. Side
C	LAD1648TRH1	Bottom Trunk Support Bracket R.H. Side
D	LAD1648TRH2	Top Trunk Support Bracket R.H. Side
E	10FOOTX or 10FOOTRFWX	10' Ladder Section
F	S-7935	1/2" x 1" Hex Bolt
G		Ladder Section

Safety Cage Installation

Safety cage entrance must be installed to the ladders within 7'-8' from the ground or platform deck.
 (See Figure 6N.)

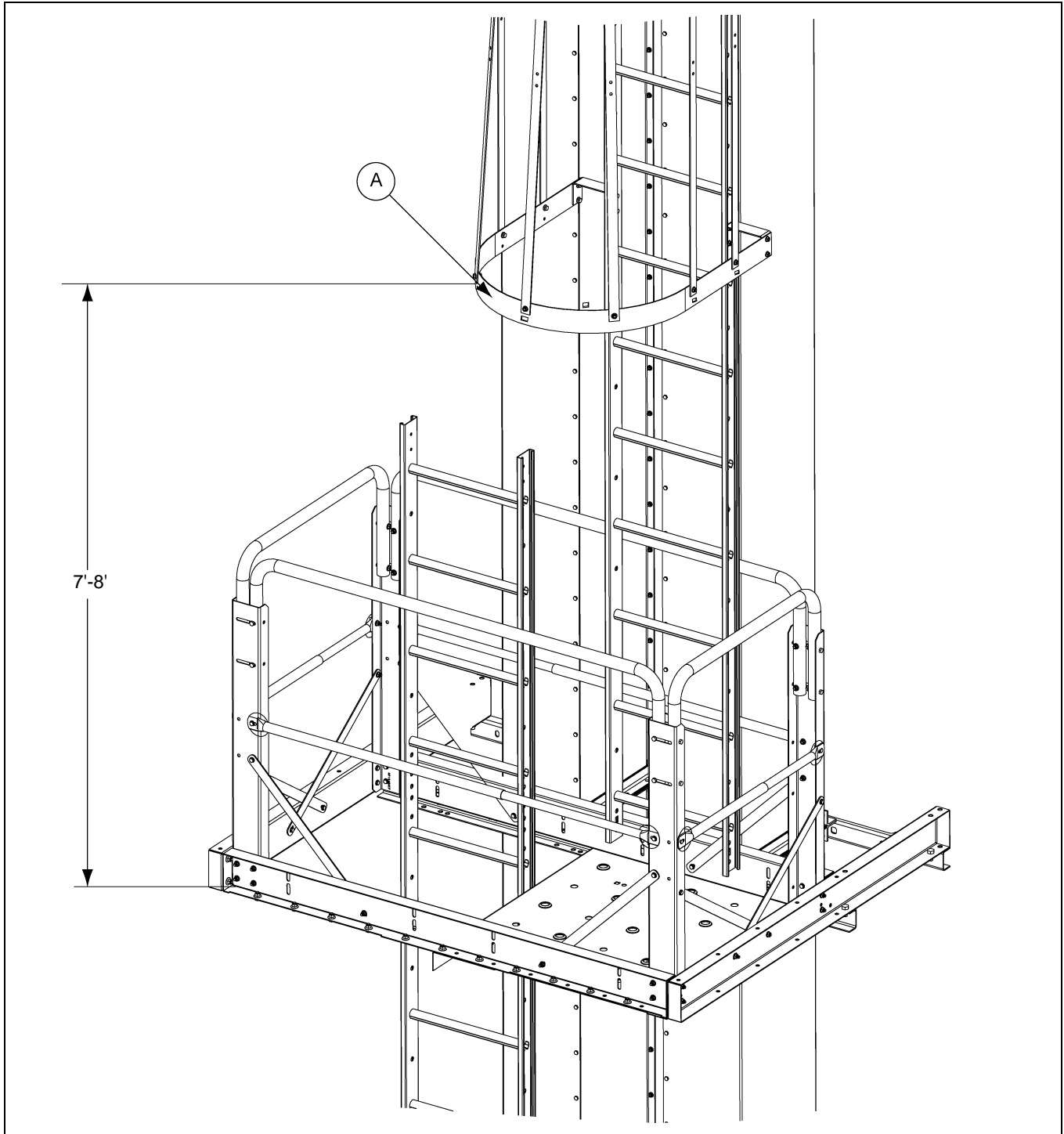

Figure 6N

Ref #	Description
A	Safety Cage

6. Tie Angles, Ladders and Safety Cages

Install Safety Cage

Safety cages are 10' sections, with the exception of the 3' entrance section.

1. Locate safety cage hoops (LDR-BCKTBHP) along the ladder rails where the safety cage hoops will be installed. **NOTE:** *The end hoops of a 10' section are spaced 4' from the two (2) middle hoops, which are spaced 2' apart. See Figure 60 for spacing. (See Figure 60.)*

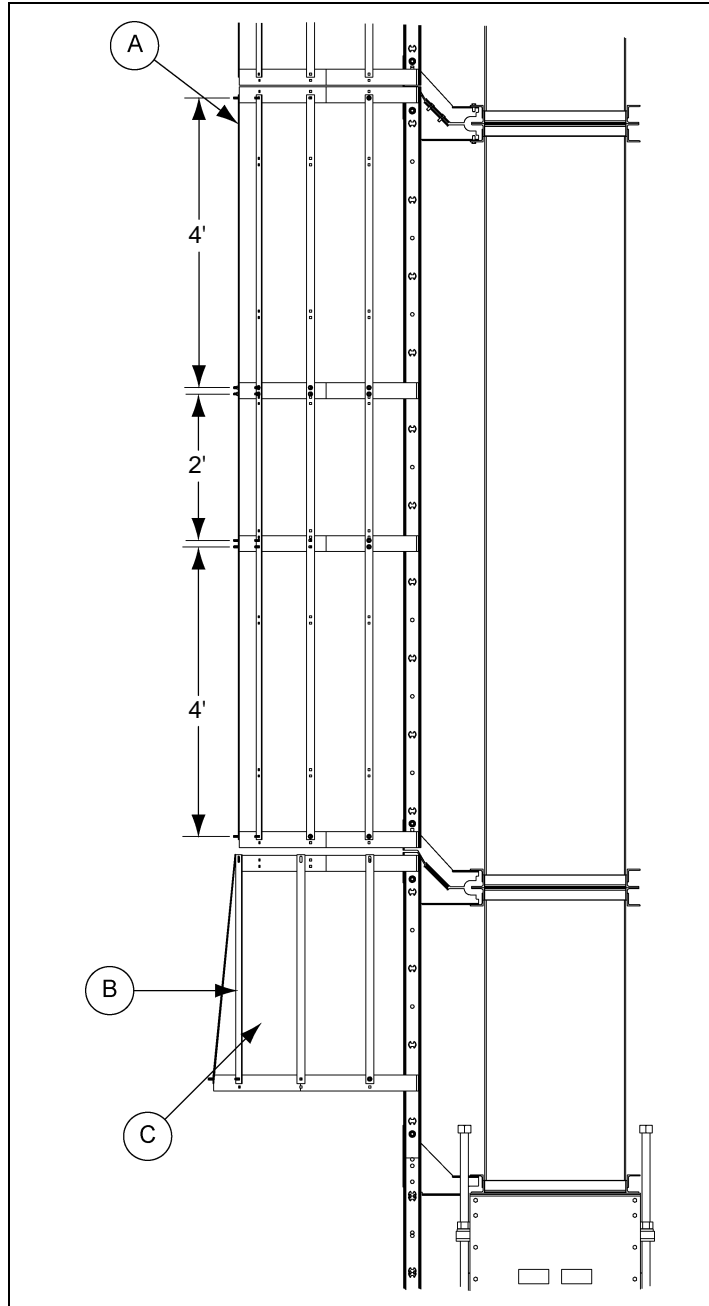

Figure 60 10' Safety Cage Section

Ref #	Part #	Description
A	LDR-10FTCAGE	10' Safety Cage Strap
B	LDR-3FTCAGE	3' Safety Cage Strap
C		3' Safety Cage Entrance Section

Install Safety Cage (Continued)

2. Attach safety cage hoops (G) to ladder using 1/2" x 1" bolts (S-7935) (D) and nuts (S-8506) (E).
 (See Figure 6P.)

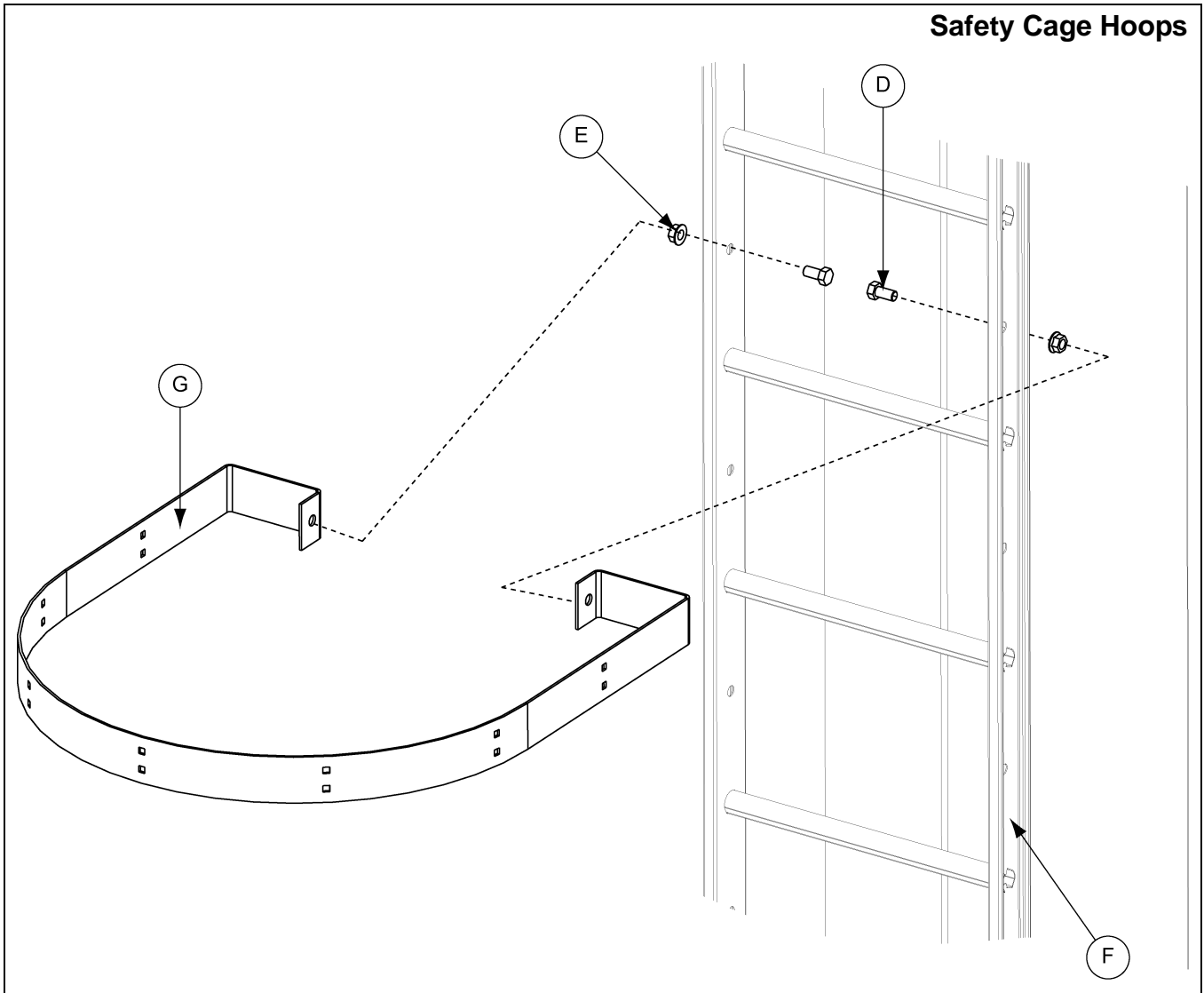

Figure 6P

Ref #	Part #	Description
D	S-7935	1/2" x 1" HHCS Bolt
E	S-8506	1/2" Flange Nut
F	10FOOTRFWX or 10FOOTX	10' Ladder Section
G		Safety Cage Hoop

6. Tie Angles, Ladders and Safety Cages

Install Safety Cage (Continued)

3. Install the seven (7) 10' safety cage straps (LDR-10FTCAGE) (A) along the safety cage hoops using 5/16" x 3/4" bolts (S-7645) (I) and nuts (S-3611) (J). **NOTE:** Bolt heads should be to the inside of the hoop. (See Figure 6Q.)

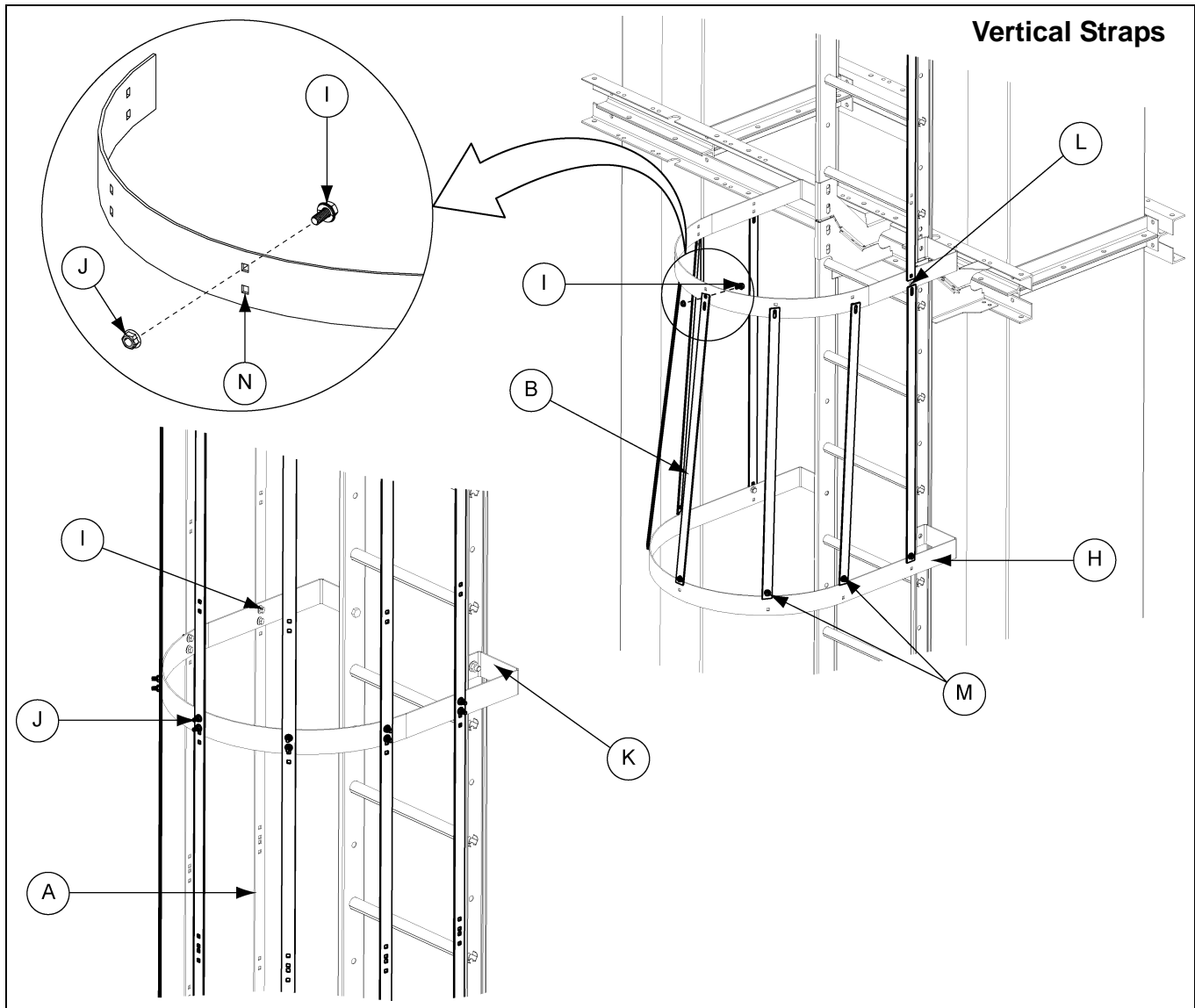

Figure 6Q

Ref #	Part #	Description
A	LDR-10FTCAGE	10' Safety Cage Strap
B	LDR-3FTCAGE	3' Safety Cage Strap
H	LDR-BCKTBHP	Safety Cage Hoop Entrance
I	S-7645	5/16" x 3/4" Bolt
J	S-3611	5/16" Flange Nut
K	LDR-BCKTHOOP	Safety Cage Hoop Standard
L		Bottom Holes
M		Top Holes
N		Leave these hole open for vertical bars.

Chapter 7: Rest Platform

Rest Platform Tie Angles to Bucket Elevators

1. Install rest platform tie angles (GECT1640FCRPX2) (A) to the lower trunking on both the ladder side and non-ladder side of the trunking. Use 1/2" x 1" bolts (S-7935) (B) through the bolt holes indicated for the bucket elevator size being installed. (See Figure 7A.)

NOTE: Bolt hole starting location on left side of tie angle is marked with the bucket size.

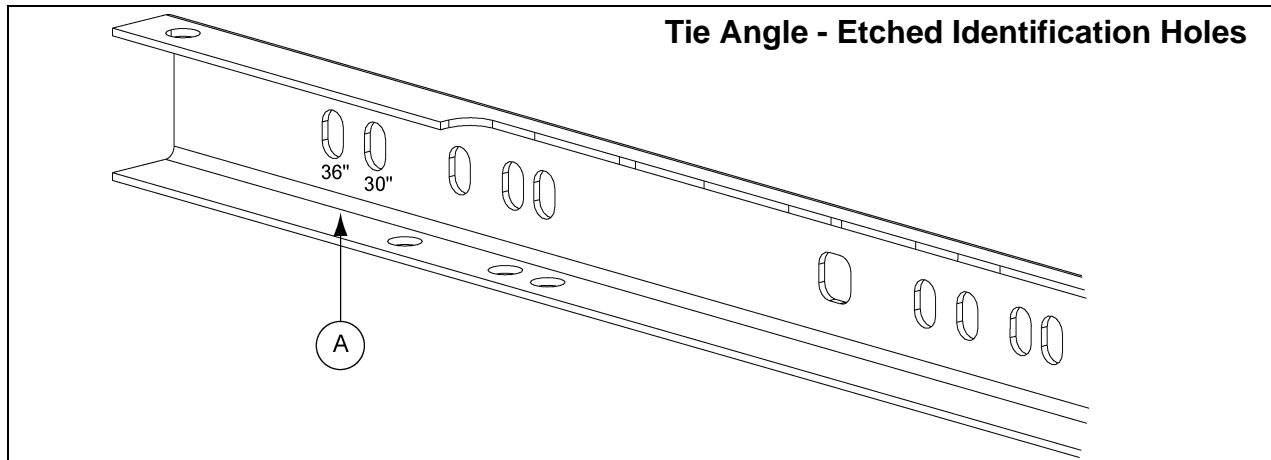

Figure 7A Tie Angle with Etched Numbers

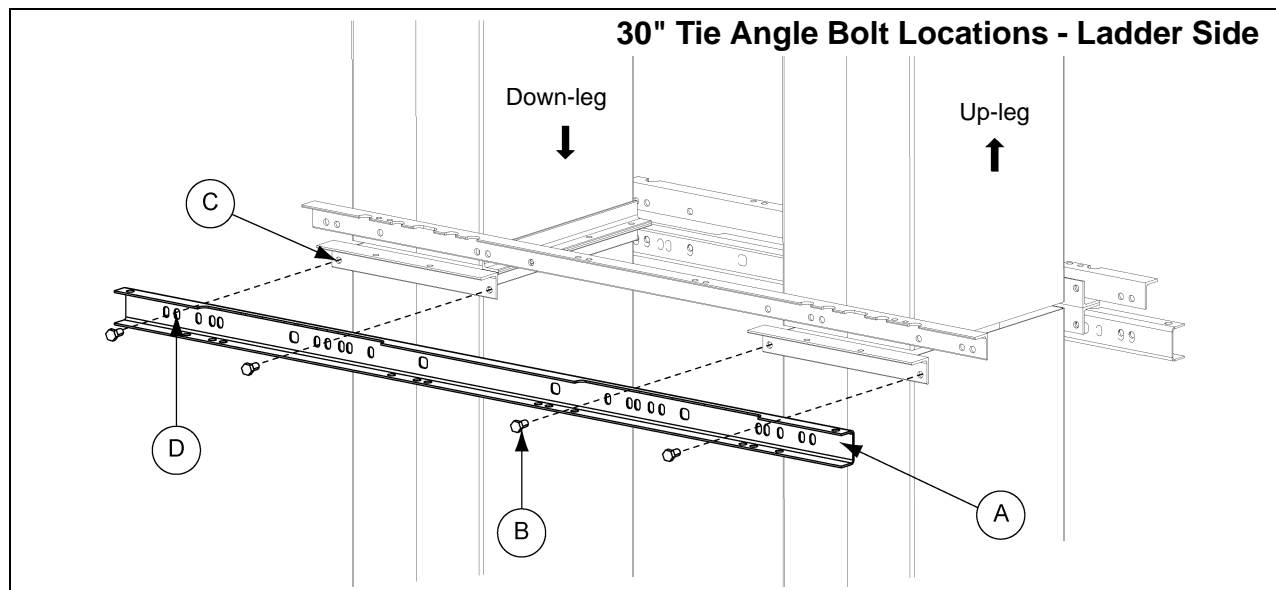

Figure 7B 30" Rest Platform Tie Angle Bolt Locations - Ladder Side

Ref #	Part #	Description
A	GECT1640FCRPX2	30"-36" Rest Platform Tie Angle
B	S-7935	1/2" x 1" Bolt
C	S-8506	1/2" Flange Nut
D		Hole Marked 30"

Rest Platform Tie Angles to Bucket Elevators (Continued)

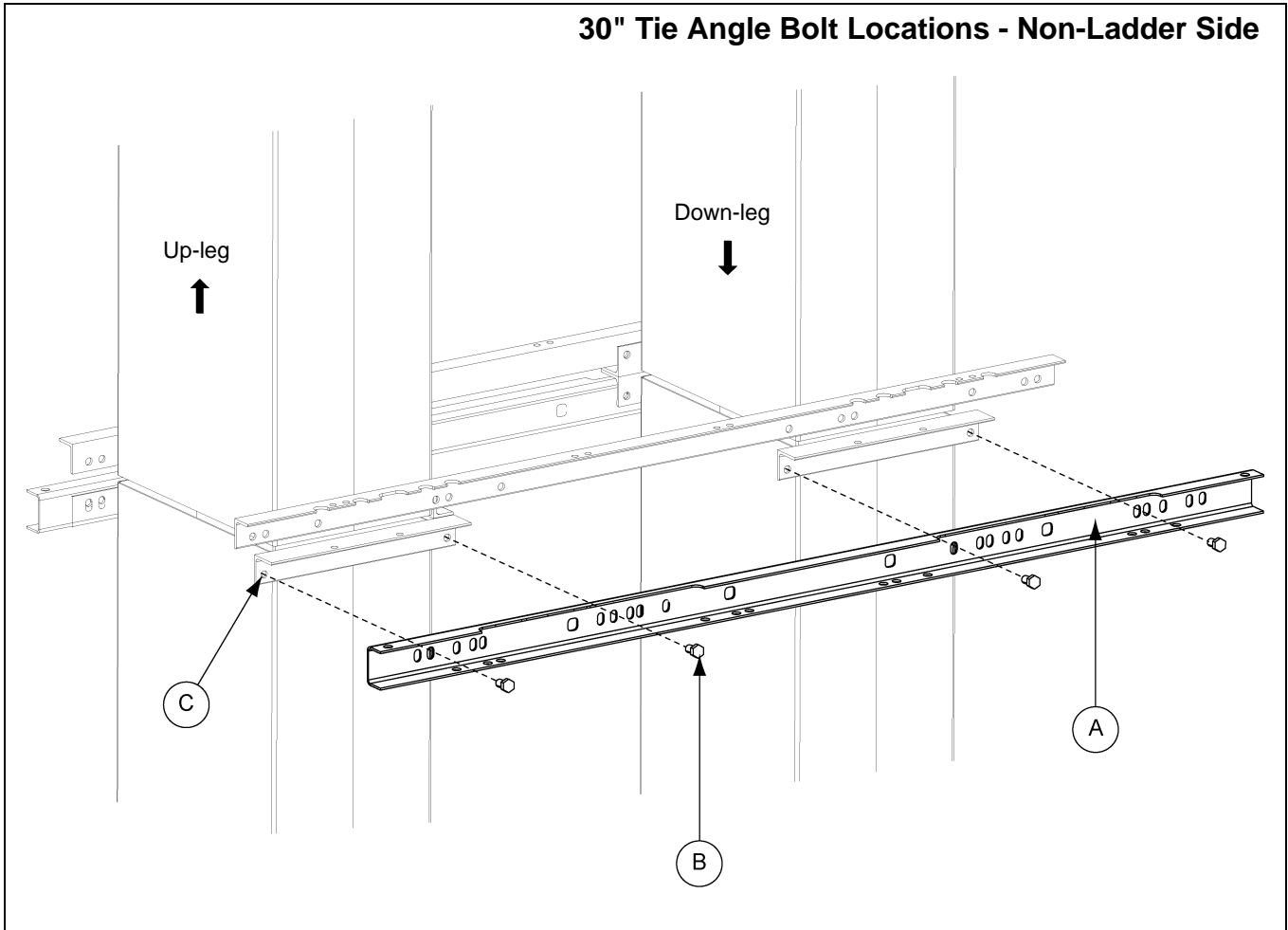

Figure 7C 30" Rest Platform Tie Angle Bolt Locations - Non-Ladder Side

Ref #	Part #	Description
A	GECT1640FCRPX2	Rest Platform Tie Angle
B	S-7935	1/2" x 1" Bolt
C	S-8506	1/2" Flange Nut

Rest Platform Tie Angles to Bucket Elevators (Continued)

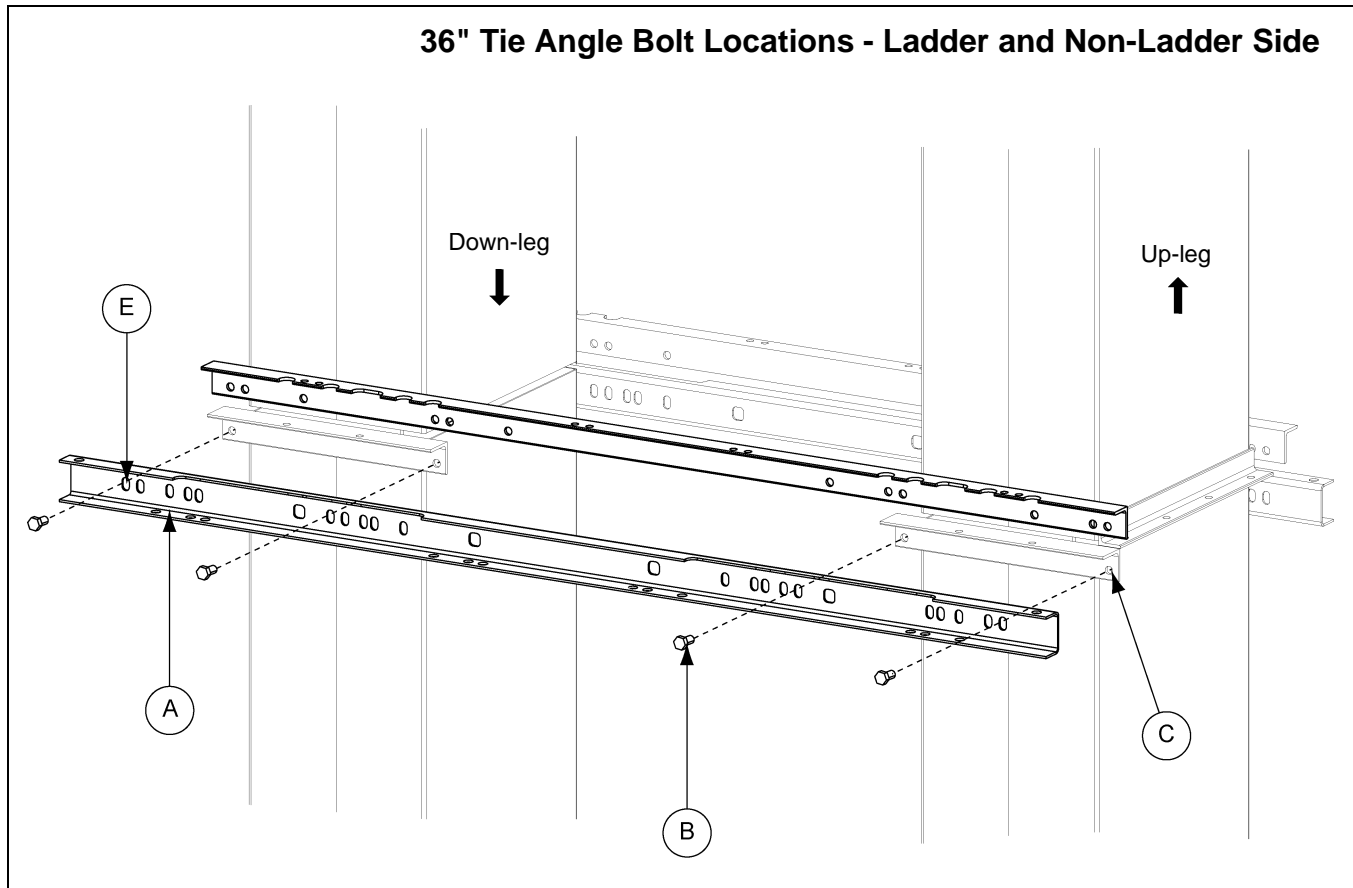

Figure 7D 36" Rest platform tie angle bolt locations - Ladder and non-ladder side have the same bolt hole locations.

Ref #	Part #	Description
A	GECT1640FCRPX2	Rest Platform Tie Angle
B	S-7935	1/2" x 1" Bolt
C	S-8506	1/2" Flange Nut
E		Hole Marked 36"

7. Rest Platform

Attach Rest Platform Channel to the Rest Platform Tie Angle

1. Connect rest platform mounting channels (RP1636MCX) (A) to the rest platform tie angles (GECT1640FCRPX2) (B) using 1/2" x 1" bolts (S-7935) (C). Bolt hole locations for 30"-36" bucket elevator will be the same. (See Figure 7E.)

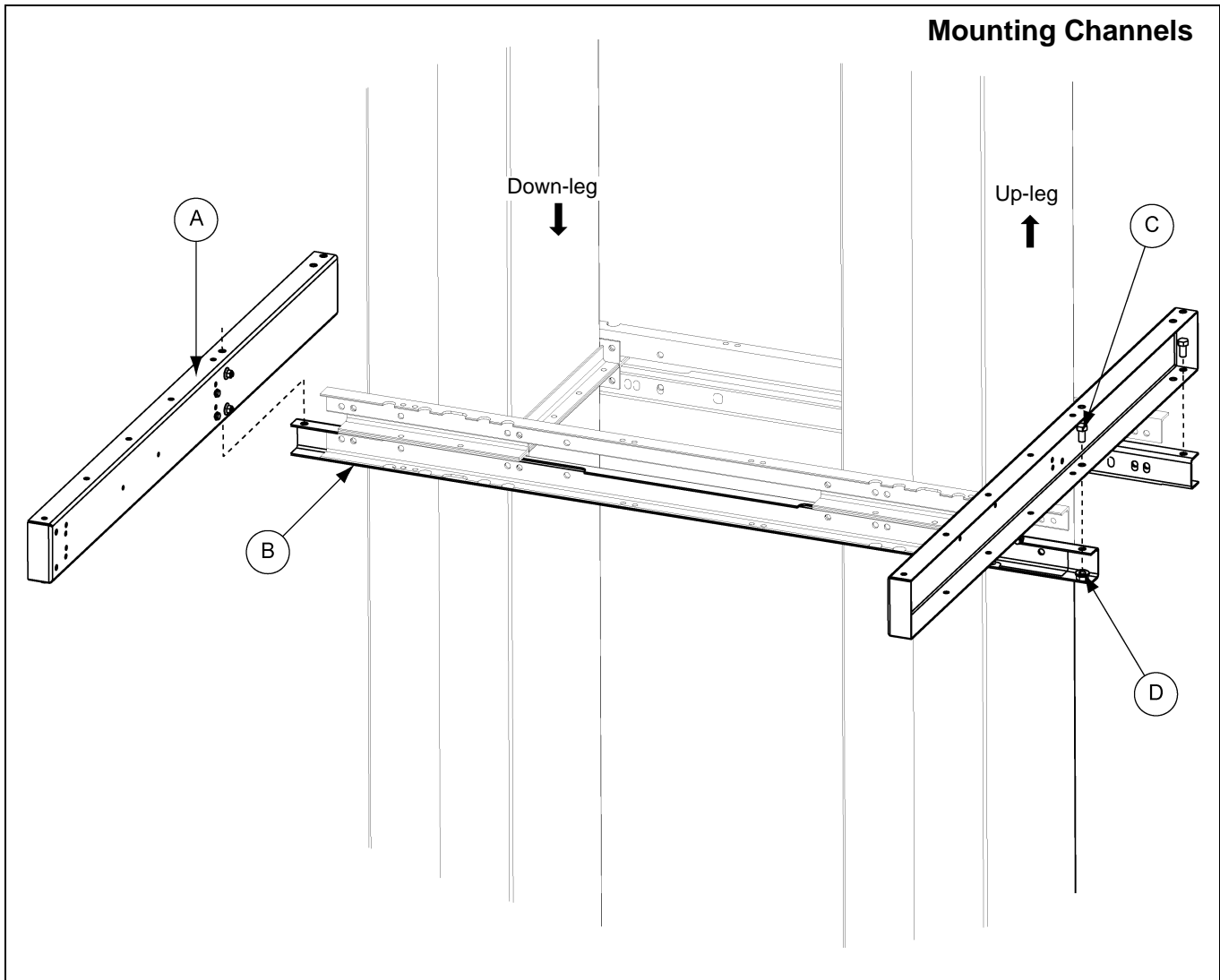

Figure 7E Bolt hole locations for 30"-36" rest platform mounting channels to tie angles.

Ref #	Part #	Description
A	RP1636MCX	30"-36" Rest Platform Mounting Channel
B	GECT1640FCRPX2	Rest Platform Tie Angle
C	S-7935	1/2" x 1" Bolt
D	S-8506	1/2" Flange Nut

Rest Platform Cross Channel to Rest Platform Mounting Channels

1. Place the rest platform cross channels (RP1636CCX) (A) between the rest platform mounting channels (RP1636MCX) (B) and connect those using 3/8" x 3/4" hex bolts (S-7105) (C). (See Figure 7F.)

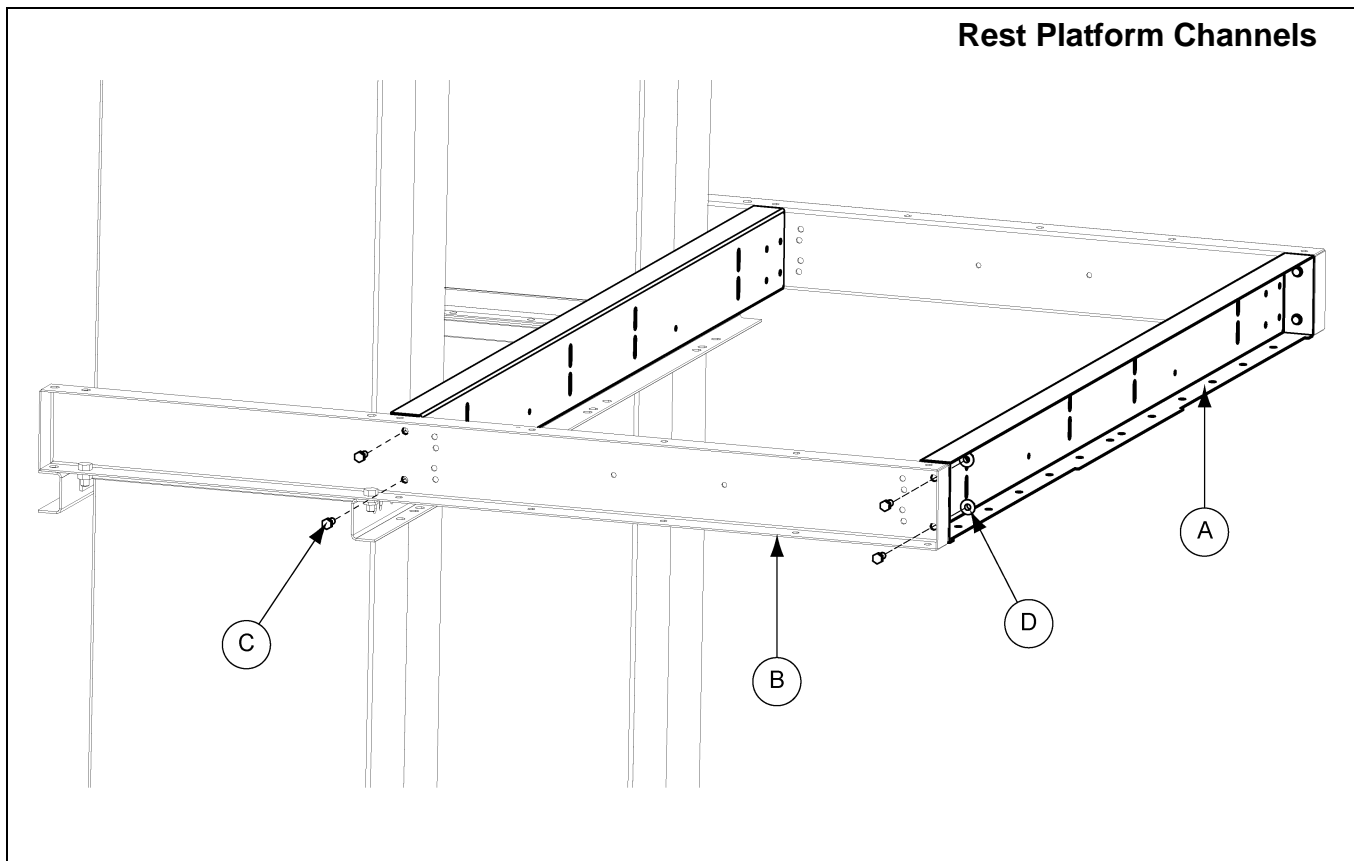

Figure 7F Rest Platform Cross Channel to Rest Platform Mounting Channels

Ref #	Part #	Description
A	RP1636CCX	Rest Platform Cross Channel
B	RP1636MCX	Rest Platform Mounting Channel
C	S-7105	3/8" x 3/4" Hex Bolt
D	S-968	3/8" Flange Nut

7. Rest Platform

Rest Platform Cross Channel to Rest Platform Mounting Channels (Continued)

2. Attach rest platform deck to the bottom of the rest platform mounting channels (RP1636MCX) (B) and rest platform cross channels (RP1636CCX) (A), using 3/8" x 3/4" hex bolts (S-7105) (C). Bolt heads should be installed against the deck plate. (See Figure 7G.) **NOTE:** The deck plate can be mounted on either the right or left side, but the flange must be mounted towards the opening.

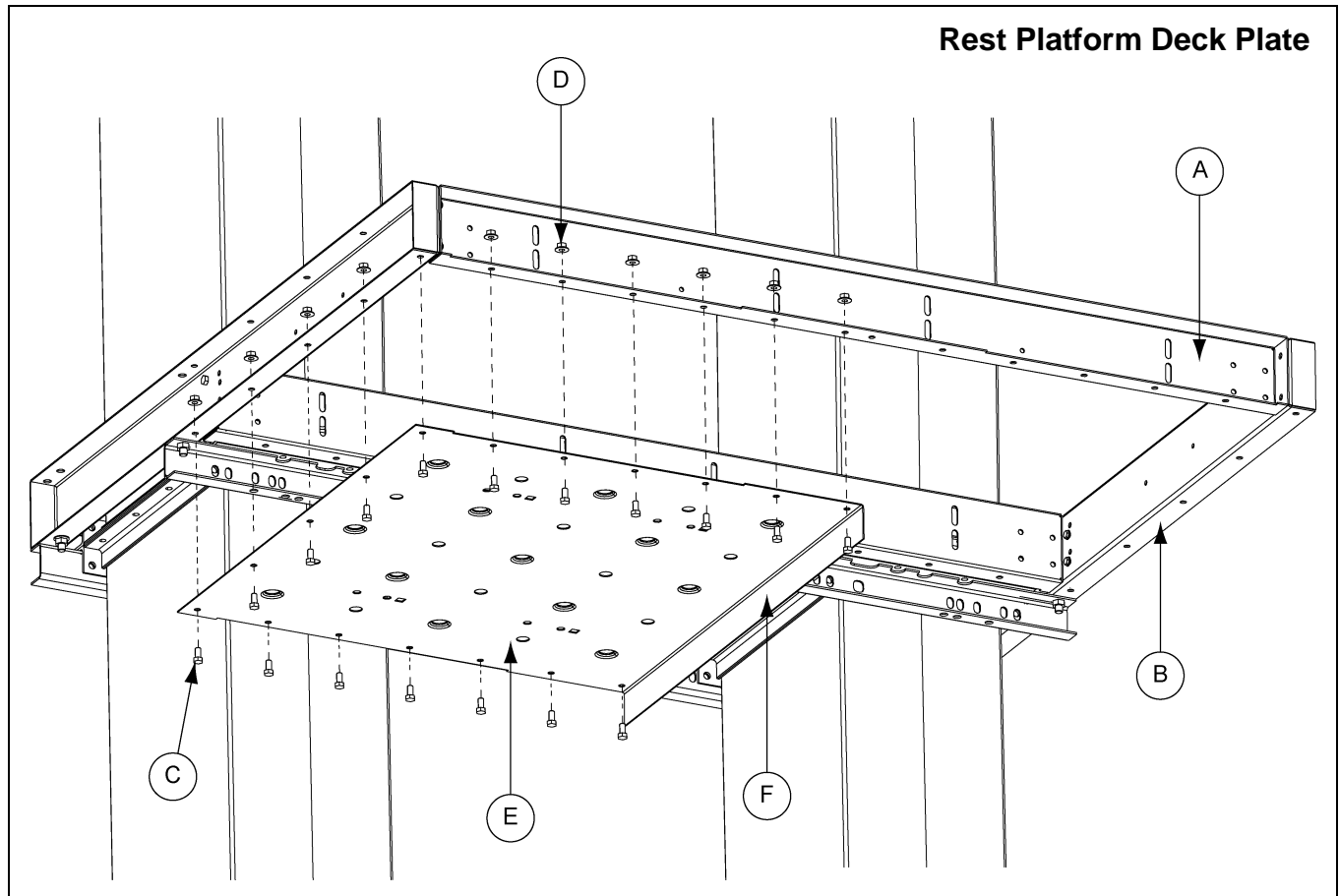

Figure 7G Deck Plate

Ref #	Part #	Description
A	RP1636CCX	Rest Platform Cross Channel
B	RP1636MCX	Rest Platform Mounting Channel
C	S-7105	3/8" x 3/4" Hex Bolt
D	S-968	3/8" Flange Nut
E	RP1636FDP	Rest Platform Flat Deck Plate
F		Deck Flange Towards Opening

Rest Platform Cross Channel to Rest Platform Mounting Channels (Continued)

3. Install the handrail platform posts (HP1648HCP) (G) to the rest platform mounting channels and rest platform channels using six (6) 5/16" x 3/4" flanged hex bolts (S-6606) (H) for each post, four (4) bolt to the front and two (2) on the side. (See Figure 7H.)

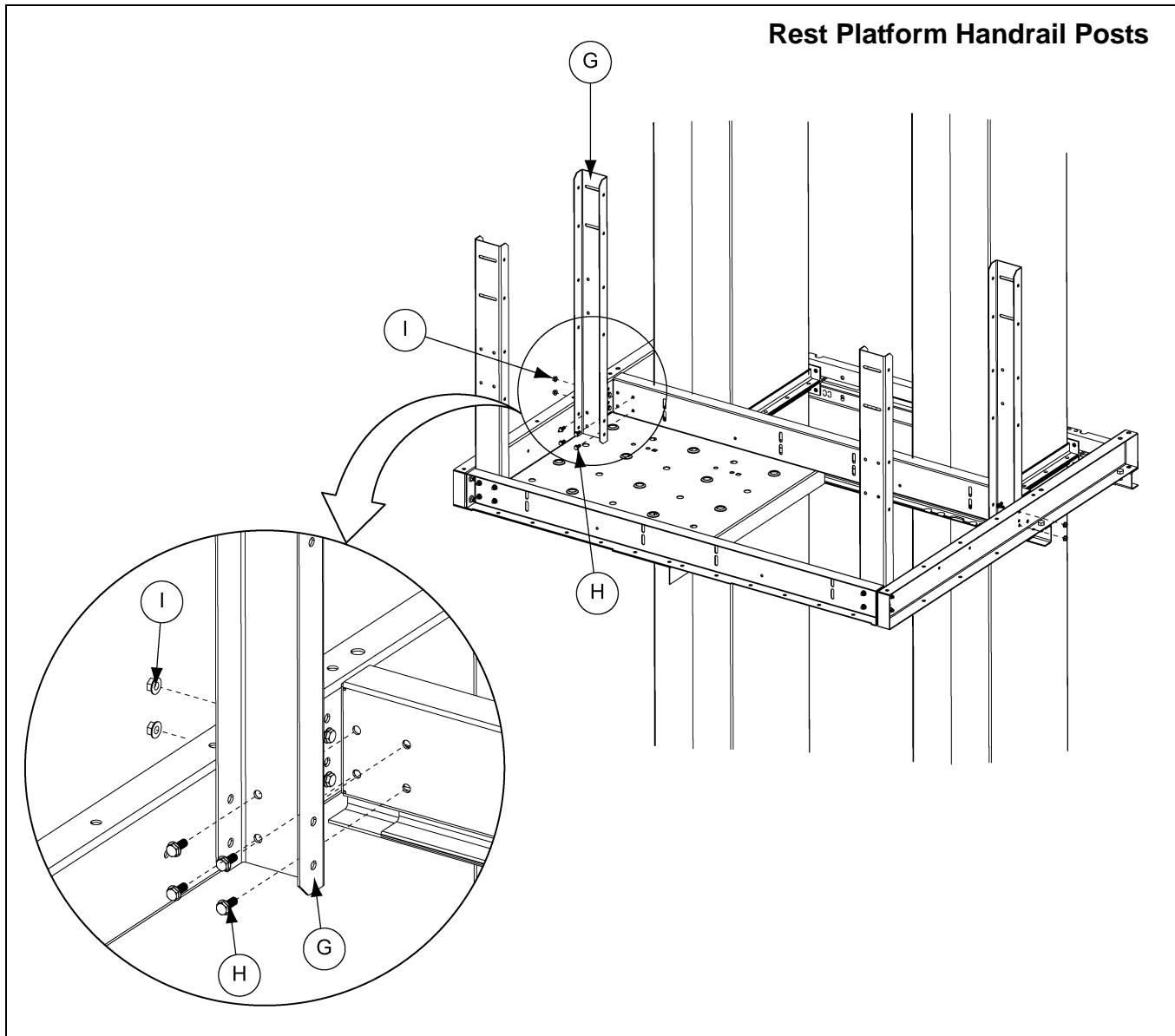

Figure 7H

Ref #	Part #	Description
G	HP1648HCP	Handrail Platform Posts
H	S-6606	5/16" x 3/4" Flange Bolt
I	S-3611	5/16" Flange Nut

7. Rest Platform

Rest Platform Cross Channel to Rest Platform Mounting Channels (Continued)

4. Assemble the intermediate handrails by sliding the small handrail into the larger handrail to create a telescoping handrail that can be adjusted to the correct length between the posts. Two (2) of the small intermediate handrails (J) and two (2) of the large intermediate handrails (K) will need to be cut to fit. The starting length of each rail is 36". Cut 18" off the end of each rail so the final length of each rail is 18". (See [Figure 71](#).)

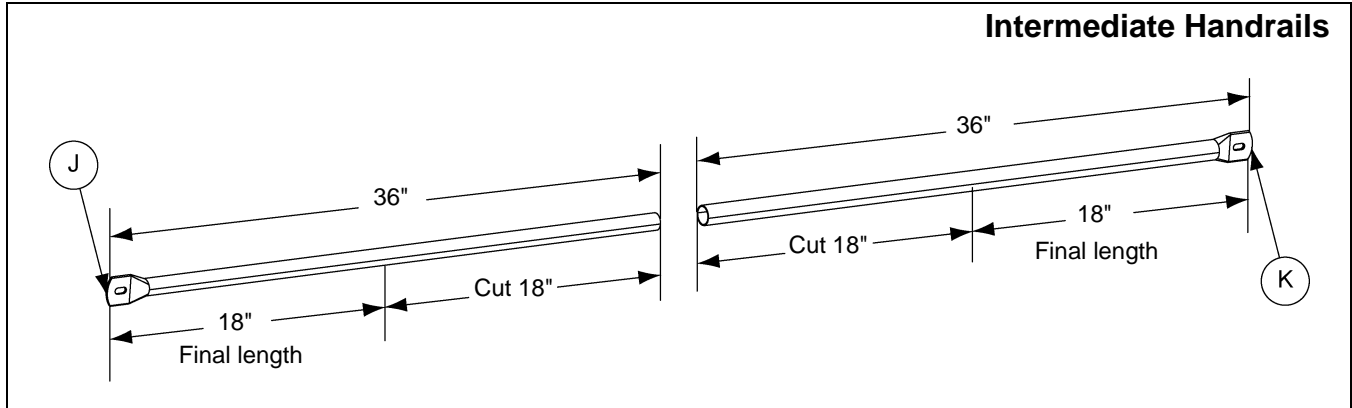

Figure 71

Ref #	Description
J	Cut Two (2) Small Intermediate Rails
K	Cut Two (2) Large Intermediate Rails

Rest Platform Cross Channel to Rest Platform Mounting Channels (Continued)

5. Install the front and back intermediate handrails to the platform posts using 5/16" x 3/4" flanged hex bolts (S-6606) (H). Adjust the rail into position by sliding it out to the correct length.
6. After cutting the two (2) large and two (2) small intermediate handrails, slide them to the correct length and install them to the handrail posts on the short sides of the platform using 5/16" x 3/4" flanged hex bolts (S-6606) (H). (See Figure 7J.)

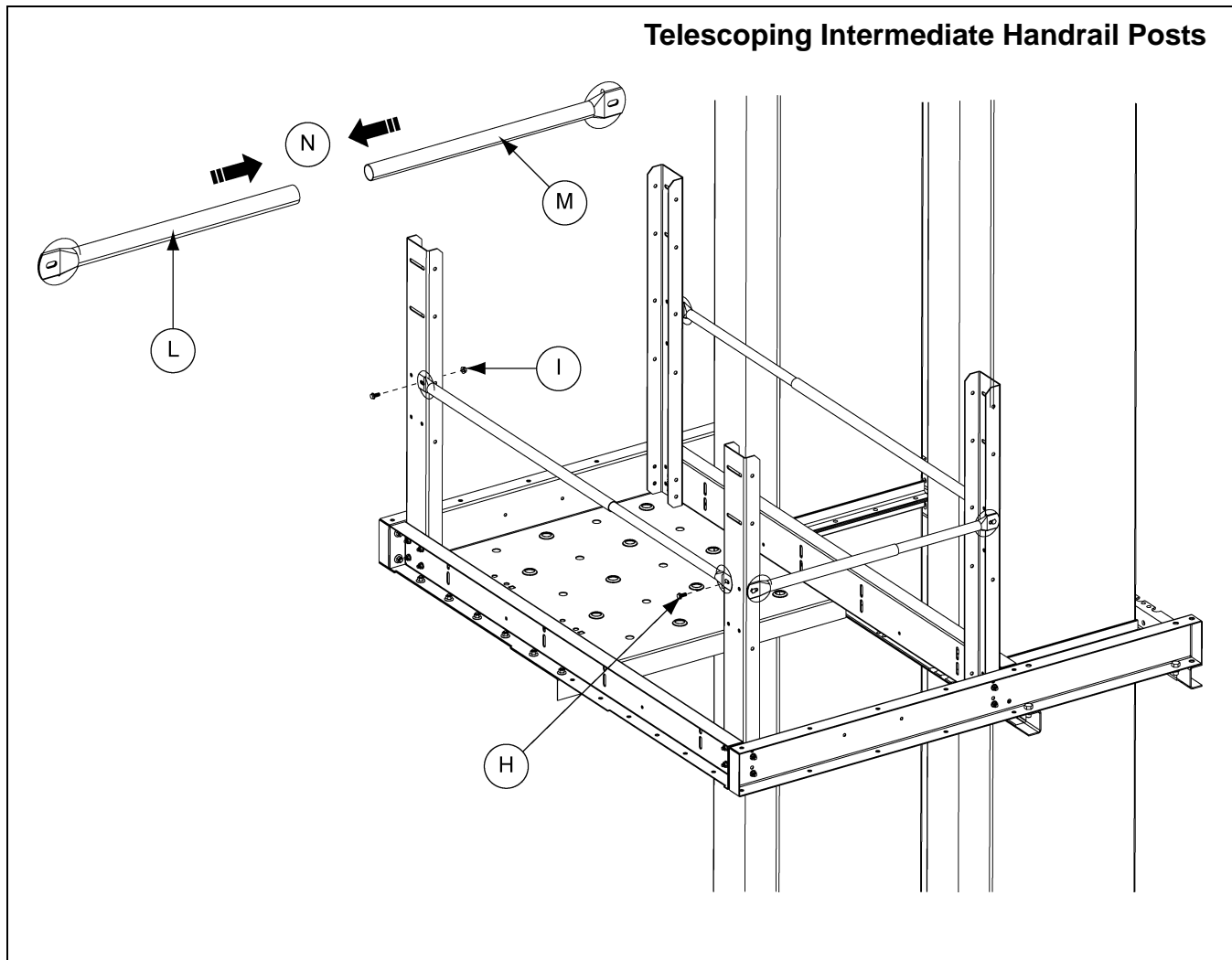

Figure 7J

Ref #	Part #	Description
H	S-6606	5/16" x 3/4" Flange Bolt
I	S-3611	5/16" Flange Nut
L	LDR-4087	Large Intermediate Handrail
M	LDR-4088	Small Intermediate Handrail
N		Slide Smaller Rail into Larger Rail

7. Rest Platform

Rest Platform Cross Channel to Rest Platform Mounting Channels (Continued)

7. Connect the front rest platform handrails and the side rest platform handrails to the handrail platform post using 5/16" x 2" hex bolts (S-7877) (Q). (See Figure 7K.)

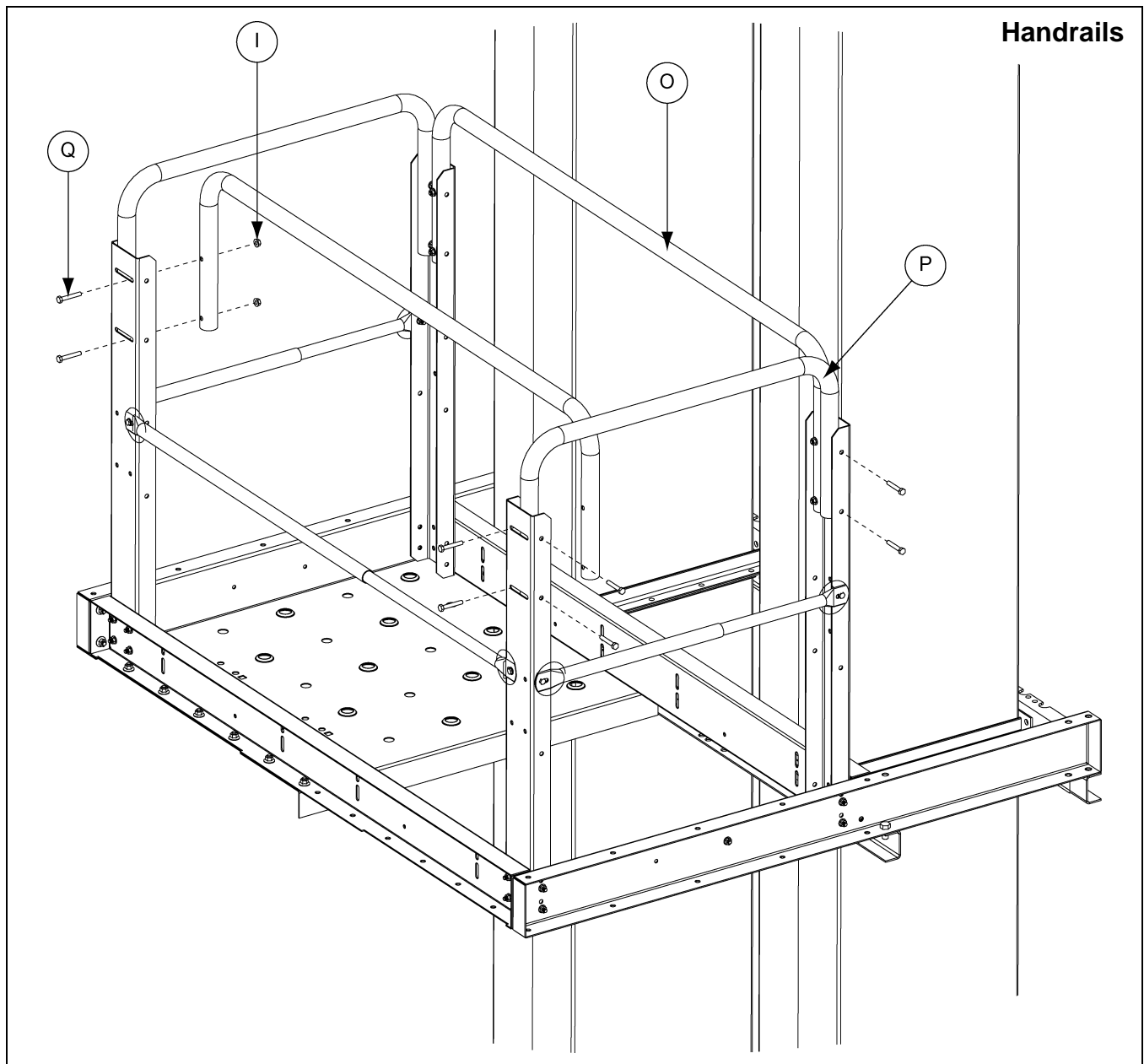

Figure 7K

Ref #	Part #	Description
O	RP1648HF	57-1/2" Handrail
P	RP1648HS	30.1" Handrail
Q	S-7877	5/16" x 2" Flange Bolt
I	S-3611	5/16" Flange Nut

Rest Platform Cross Channel to Rest Platform Mounting Channels (Continued)

8. Platform braces must be installed from handrail posts to mounting and cross channels using 5/16" x 3/4" flanged hex bolts (S-6606) (H). Braces should be attached to the outside of the platform post and to the inside of the mounting and cross channels. **NOTE:** Safety cage bars (LDR-5171BE) (R) are used as platform braces/tie angle braces through out this installation. Bolt heads should be on inside of platforms. (See Figure 7L.)

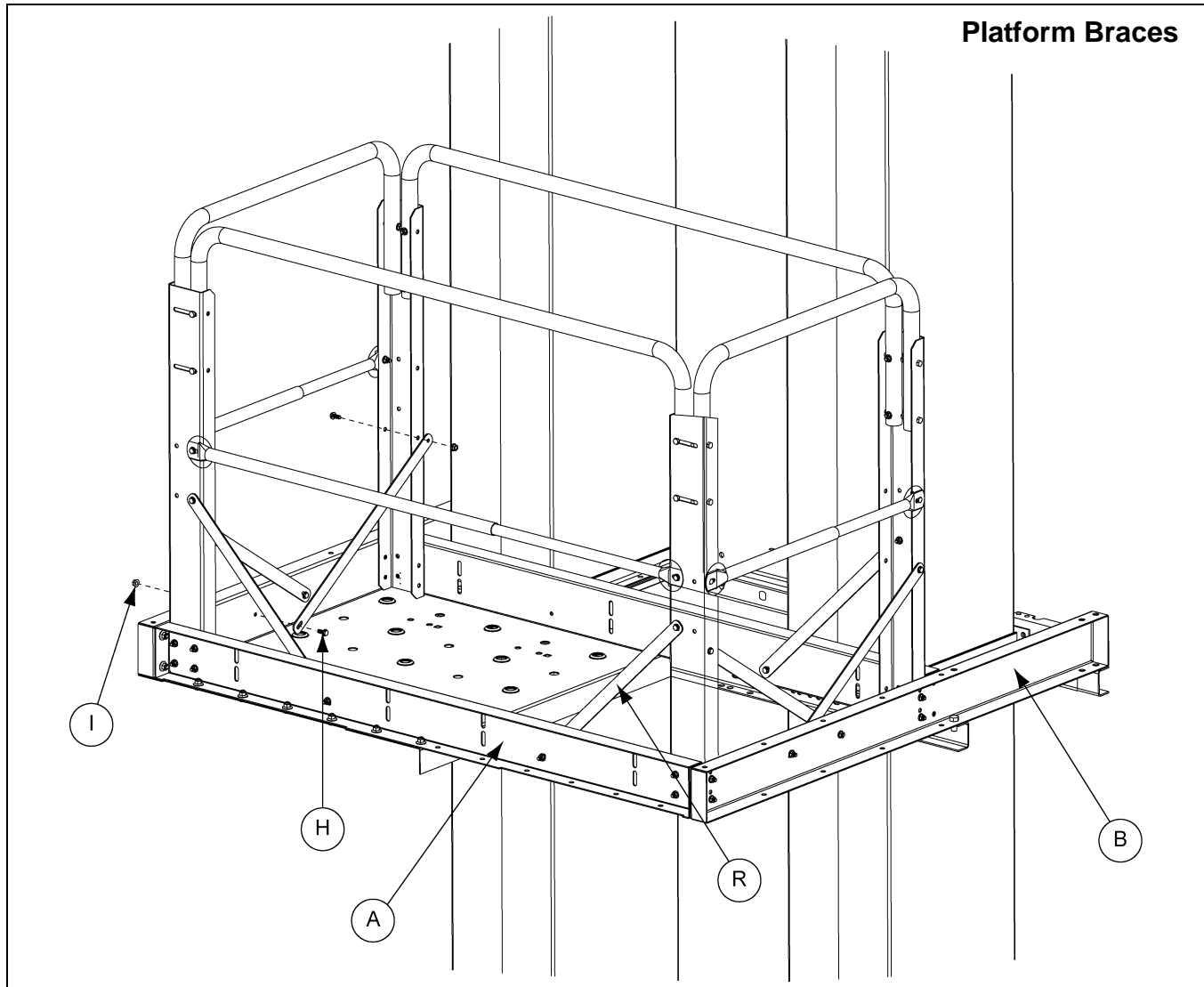

Figure 7L

Ref #	Part #	Description
A	RP1636CCX	Rest Platform Cross Channel
B	RP1636MCX	Rest Platform Mounting Channel
H	S-6606	5/16" x 3/4" Flange Bolt
I	S-3611	5/16" Flange Nut
R	LDR-5171BE	Brace

7. Rest Platform

Rest Platform Cross Channel to Rest Platform Mounting Channels (Continued)

9. Install ladder support brackets to the rest platform cross channel (RP1636CCX) (A) using 3/8" x 3/4" hex bolts (S-7105) (C).
10. Attach ladders to ladder support brackets using 1/2" x 3/4" hex bolts (S-7932) (U). (See Figure 7M.)

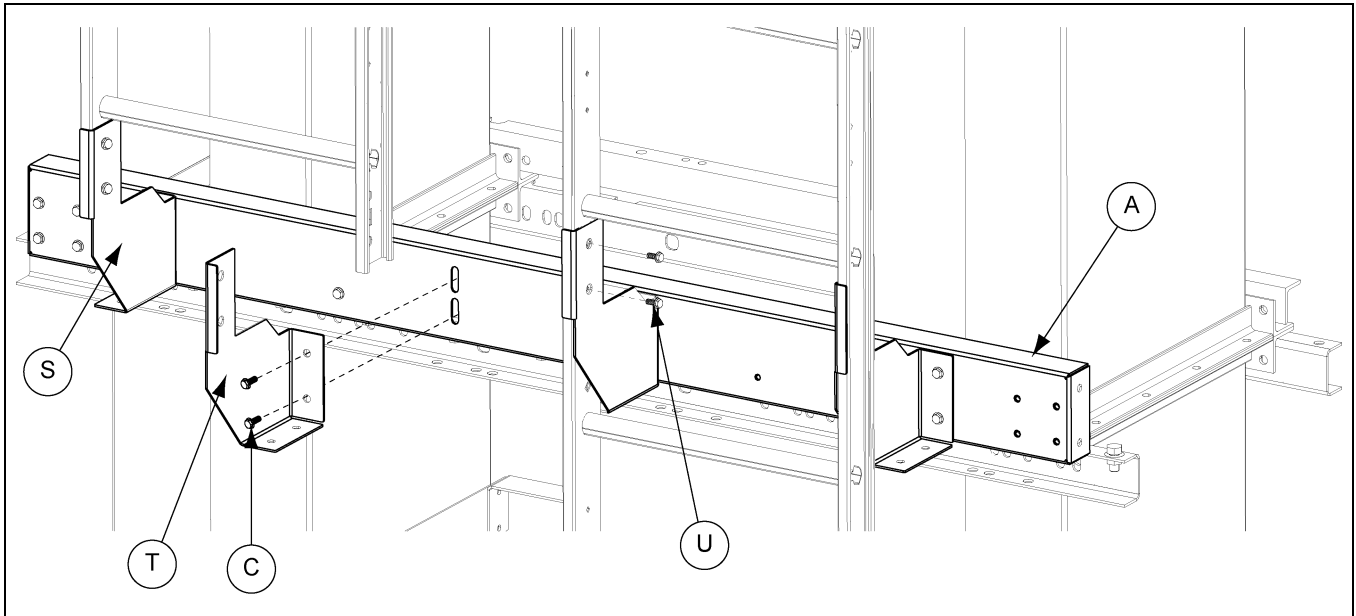

Figure 7M

Ref #	Part #	Description
A	RP1636CCX	Rest Platform Cross Channel
C	S-7105	3/8" x 3/4" Hex Bolt
S	LAD1648BLH	Bracket, Ladder Support L.H.
T	LAD1648BRH	Bracket, Ladder Support R.H.
U	S-7932	1/2" x 3/4" Hex Bolt

Ladder Support

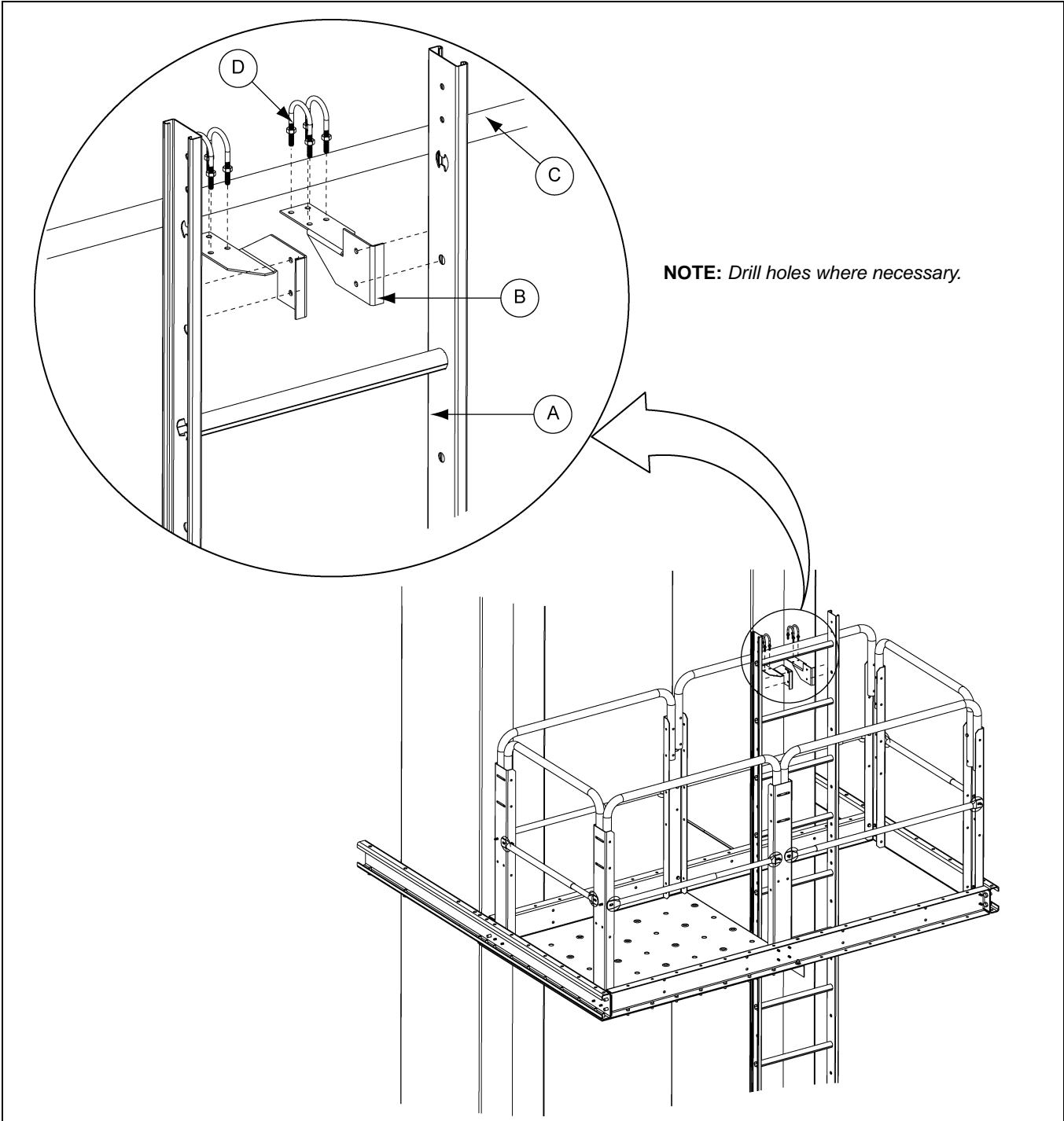

Figure 7N

Ref #	Part #	Description
A	14FOOTRFWX or 14FOOTX	14' Ladder Section
B	RP1648LS	Ladder Support Rest Platform
C	RP1648HSX	48" HSP Sides 43.605" Outside Handrail
D	S-10136	U-Bolt 1/4"-20 x 1-1/2"

Chapter 8: 30"-36" Head Platform Right Hand Drive

To facilitate quick and easy assembly, numerous parts are pre-assembled prior to shipping.

Considerable time is dedicated at the beginning of this manual to the proper orientation of channels and decks. This is because the orientation of these elements is essential to the proper construction of the head platform.

1. There are many ways to get the orientation wrong and only one way to get it right.
2. Proper orientation of the channels and decks is essential proper assembly.
3. Proper construction of the head platform can only be completed if the initial orientation of the channels is done correctly.

Therefore, we strongly advise you take time to confirm that the orientation of these early elements is correct before you begin to assemble the decking on to the channels.

To facilitate proper connections, major connecting holes are etched with alpha-numeric codes. One side is labeled **X1** through **X7**, this side is referred to as the “**X**” side. The opposite side is labeled with **Y1** through **Y7** and is referred to as the “**Y**” side.

Attach Cross Deck Support Channels to Lower Head

Three (3) cross deck support channels support the platform. Two (2) of the channels are attached to brackets on the lower head section and the third channel is attached to the decking itself but is not attached directly to the lower head. This third channel will be attached after the deck is assembled. (See Figure 8A.)

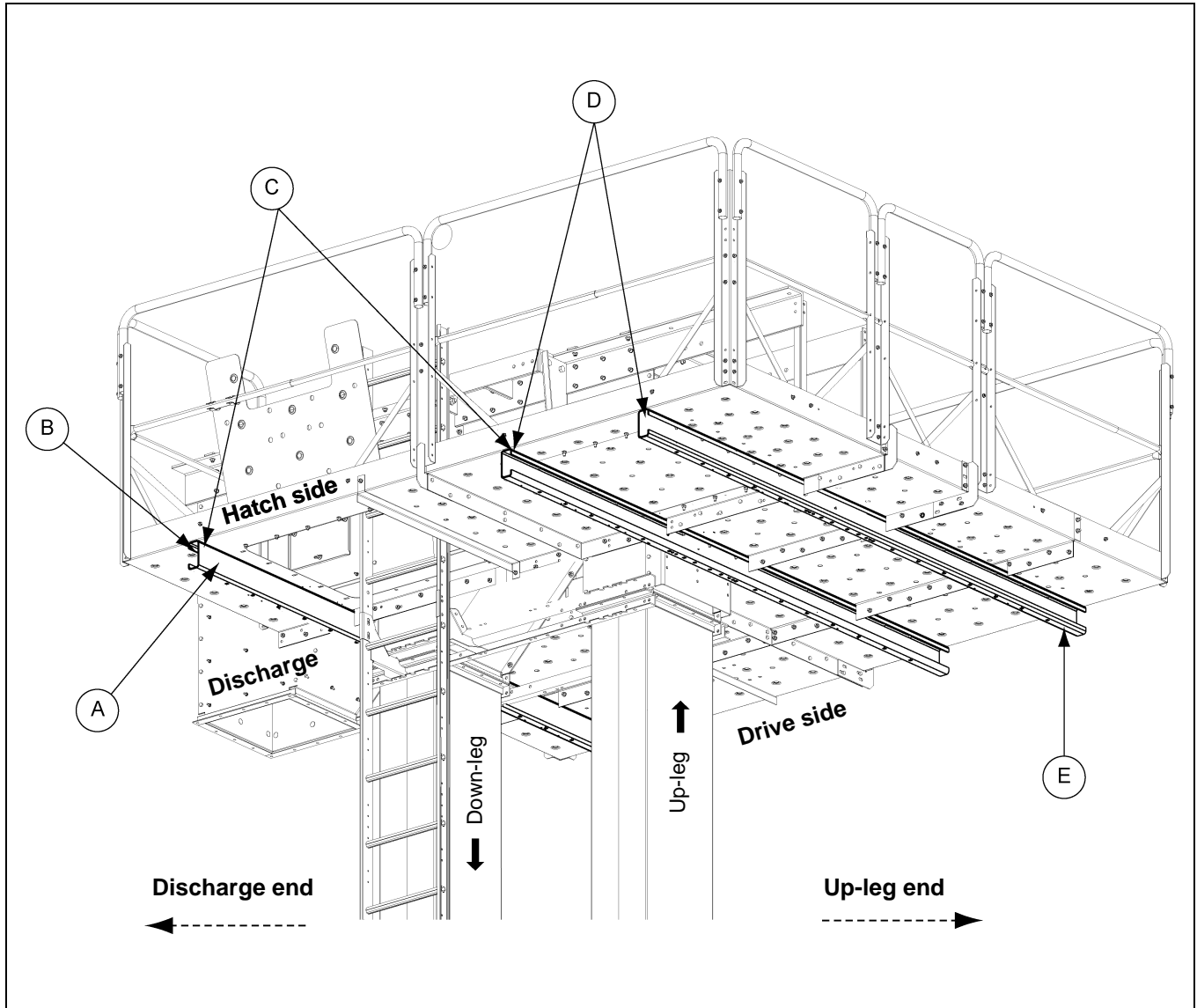

Figure 8A 30"-36" Platform Overview

Ref #	Description
A	For 30" this channel would flip over and be oriented the same as the other two (2) channels, "Y" side up.
B	Channels "X" side up ("X1" starts here) (for 36")
C	These cross deck support channels connect directly to bracket on the lower head.
D	Channels "Y" side up ("Y1" starts here)
E	This channel is installed later, after the decking has been assembled.

Attach Main Support Channels to Lower Head

For 30" Right Side Drive

Orient the Channel

Place lower head section on solid and level surface.

1. At **Discharge End** orient the channel so that:
 - a. Channel opening is inward, toward the bracket.
 - b. Hole labeled with "Y" face up.
 - c. Holes **Y1** is on the non-drive/hatch side of the lower head.
 - d. Hole **Y7** is on the drive side of the lower head.
 - e. Cross deck support channel extends farther on the drive side than on hatch side of lower head.
2. At **Up-Leg End** orient the channel so that:
 - a. Channel opening outward, toward the up-leg end of the head.
 - b. Holes labeled with "Y" face up.
 - c. Hole **Y1** is on the non-drive side of the lower head.
 - d. Hole **Y7** is on the drive side of the lower head.
 - e. Cross deck support channel extends farther on the drive side than on hatch side of lower head.
(See [Figure 8C on Page 53.](#))
3. Attach cross deck support channels (HP36CDSCX) to the top-most set of holes of the lower head brackets (HSP36130) using 3/8" x 1" bolts and nuts and properly. (See [Figure 8C on Page 53.](#))

***NOTE:** *The channels MUST be oriented as shown in [Figure 8B](#) and [Figure 8C on Page 53](#) in order for the decking and subsequent assembly to be done correctly.*

8. 30"-36" Head Platform Right Hand Drive

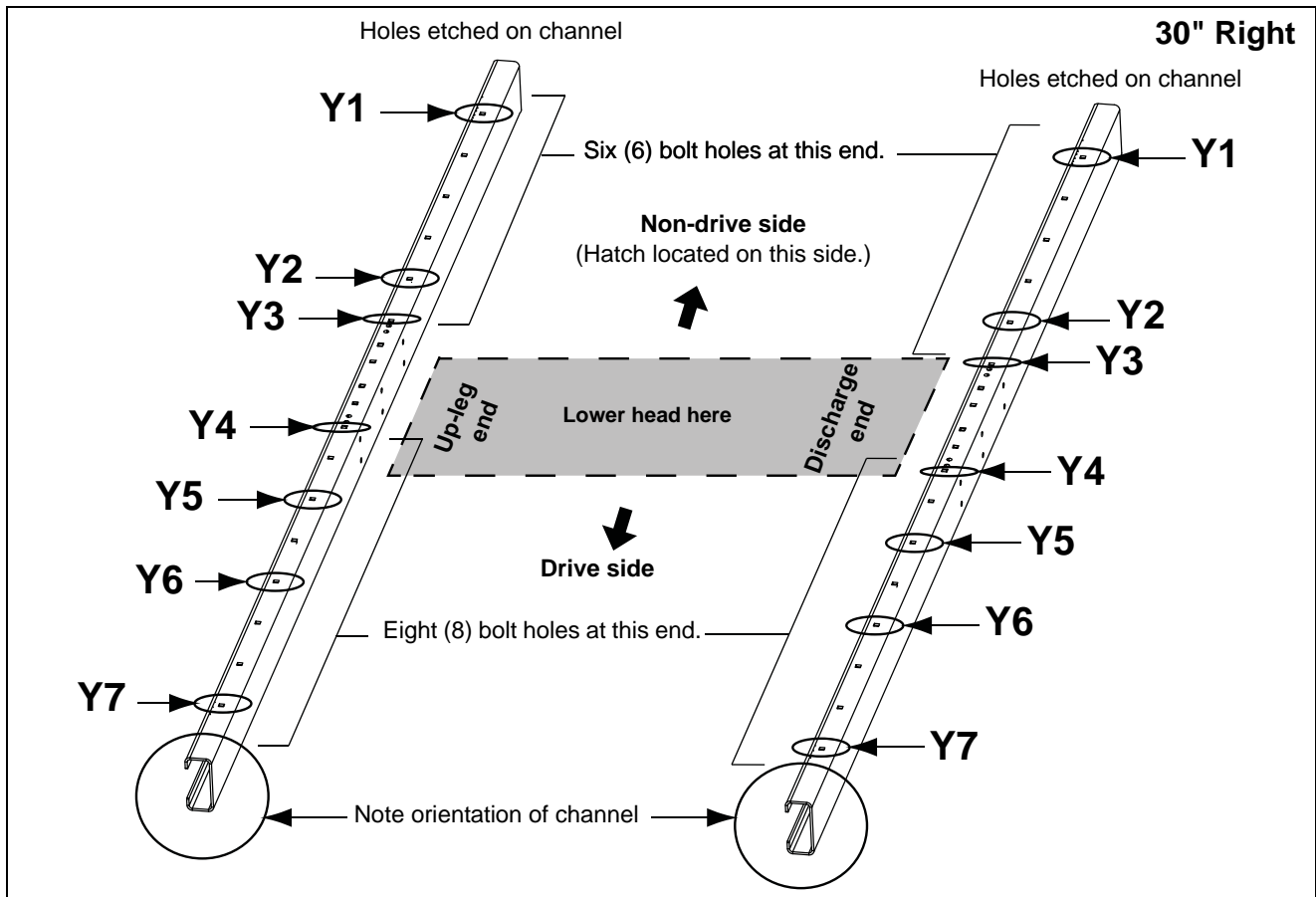

Figure 8B 30" Right Side Drive Channel Position

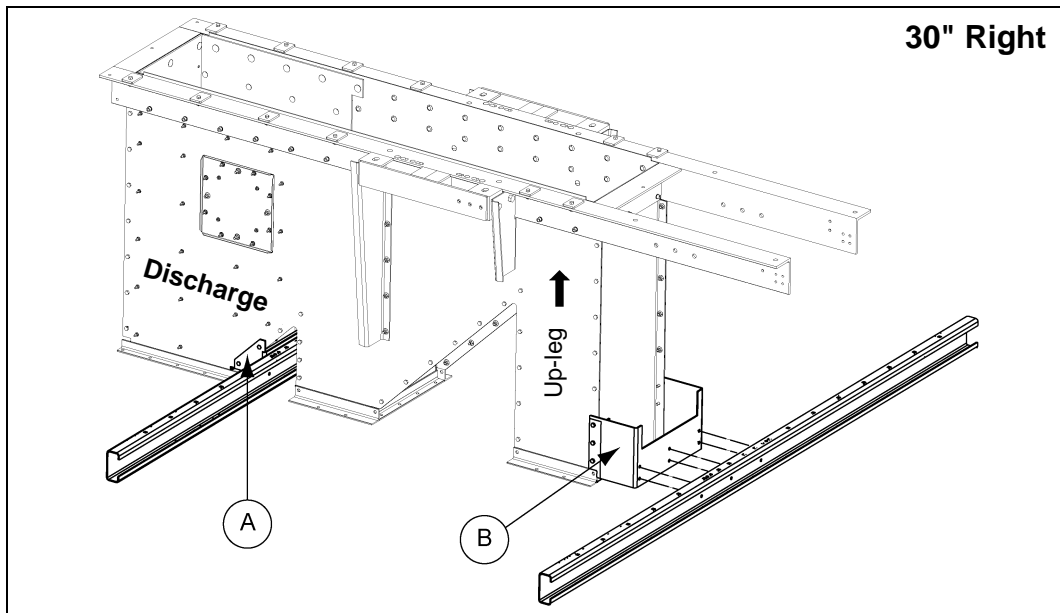

Figure 8C 30" Right Drive - Cross Deck Support Channels to Lower Head Brackets

Ref #	Part #	Description
A	HP30XLHPSA	30" HP Lower Head Discharge Bracket
B	HP30XLHPS	30" HP Lower Head Bracket

8. 30"-36" Head Platform Right Hand Drive

For 36" Right Side Drive

Orient the Channel

Place lower head section on solid and level surface.

1. At the **Discharge End** orient the channel so that:
 - a. Channel opening is outward, toward the discharge end of the head.
 - b. Holes labeled with "X" face up.
 - c. Hole **X1** is on the non-drive side of the lower head.
 - d. Hole **X7** is on the drive side of the lower head.
 - e. Cross deck support channel extends farther on the drive side than on hatch side of lower head.
 2. At the **Up-Leg End** orient the channel so that:
 - a. Channel opening outward, toward the up-leg end of the head.
 - b. Holes labeled with "Y" face up.
 - c. Hole **Y1** is on the non-drive side of the lower head.
 - d. Hole **Y7** is on the drive side of the lower head.
 - e. Cross deck support channel extends farther on the drive side than on hatch side of lower head.
(See [Figure 8D on Page 55.](#))
 3. Attach cross deck support channels (HP36CDSCX) to the top-most set of holes of the lower head brackets (HSP36130) using 3/8" x 1" bolts and nuts and torque properly. (See [Figure 8E on Page 55.](#))
- *NOTE:** *The channels MUST be oriented as shown in [Figure 8D](#) and [Figure 8E](#) on Page 55 in order for the decking and subsequent assembly to be done correctly.*

8. 30"-36" Head Platform Right Hand Drive

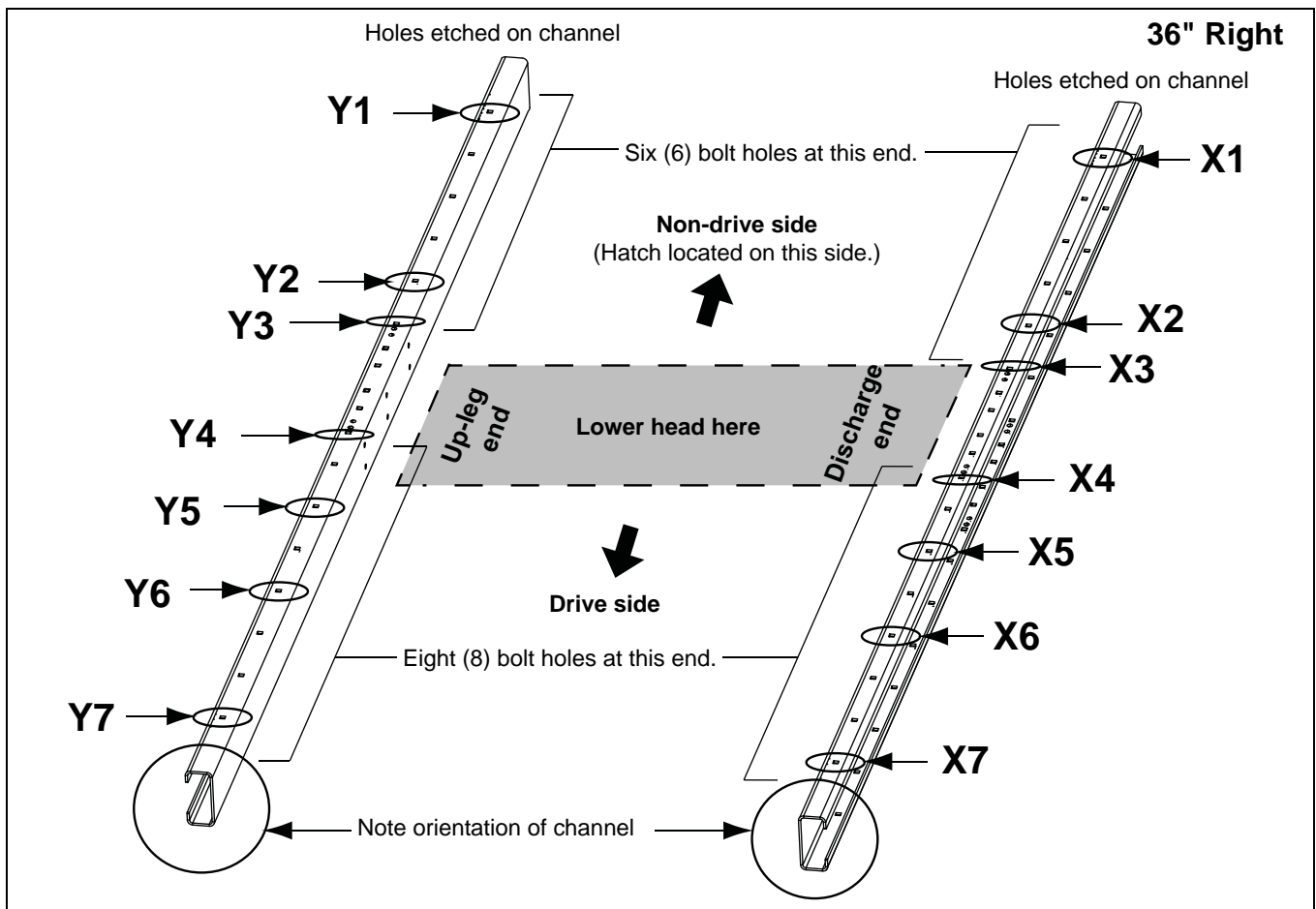

Figure 8D 36" Right Side Drive Channel Position

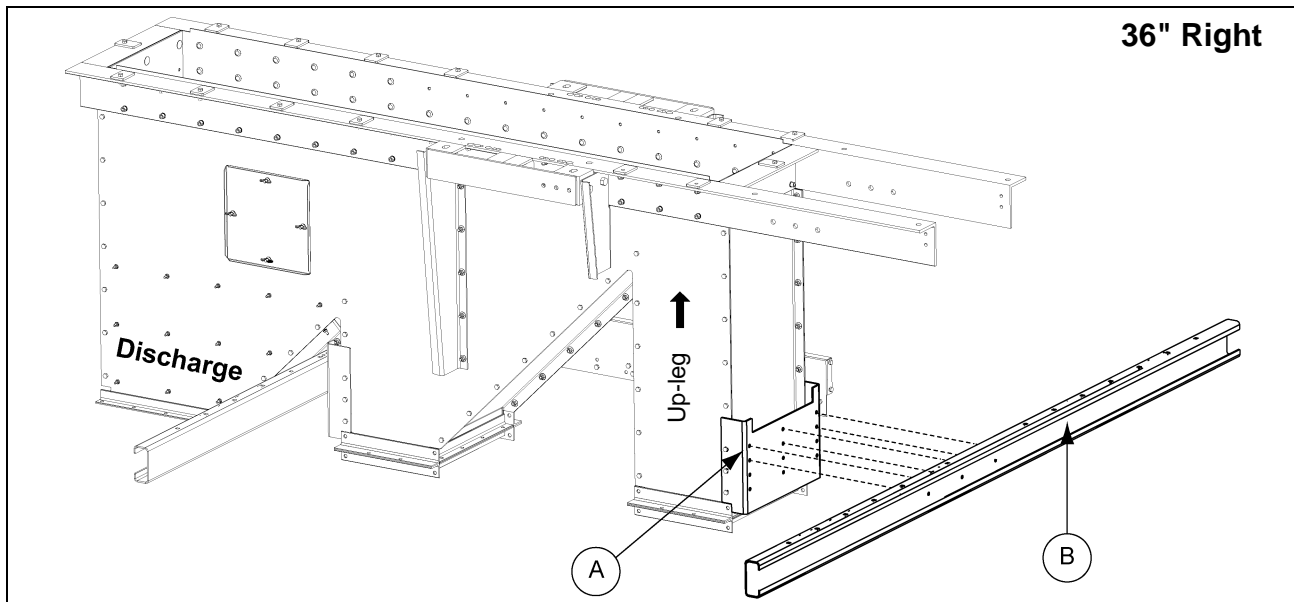

Figure 8E

Ref #	Part #	Description
A	HSP36130	Lower Head Bracket
B	HP36CDSCX	Cross Deck Support Channel

8. 30"-36" Head Platform Right Hand Drive

Attach Deck A to Hatch Cover Plate

NOTE: Only two (2) side of deck plate are attached at this time.

1. Locate pre-assembled Deck A. This plank consists of the two (2) hatch openings and is labeled with holes etched with the letter A.
2. Orient Deck A so the hatch cover plate is at the up-leg end of the deck.
3. The hatch will be located at the discharge end and will remain open at this time. A hatch door will be attached to Deck A later and should NOT be installed at this time.

NOTE: ONLY connect the hatch filler plate along two (2) of the four (4) sides of the plate.

4. The holes perpendicular to the length of Deck A should remain open at this time as they will serve to connect the hatch cover plate and Deck A to the cross deck support channel.
5. Attach the hatch cover plate to Deck A using (8) eight 3/8" x 1" carriage bolts (S-3585) with flange nuts (S-10028) and torque to 30 ft/lbs. (See Figure 8F.)

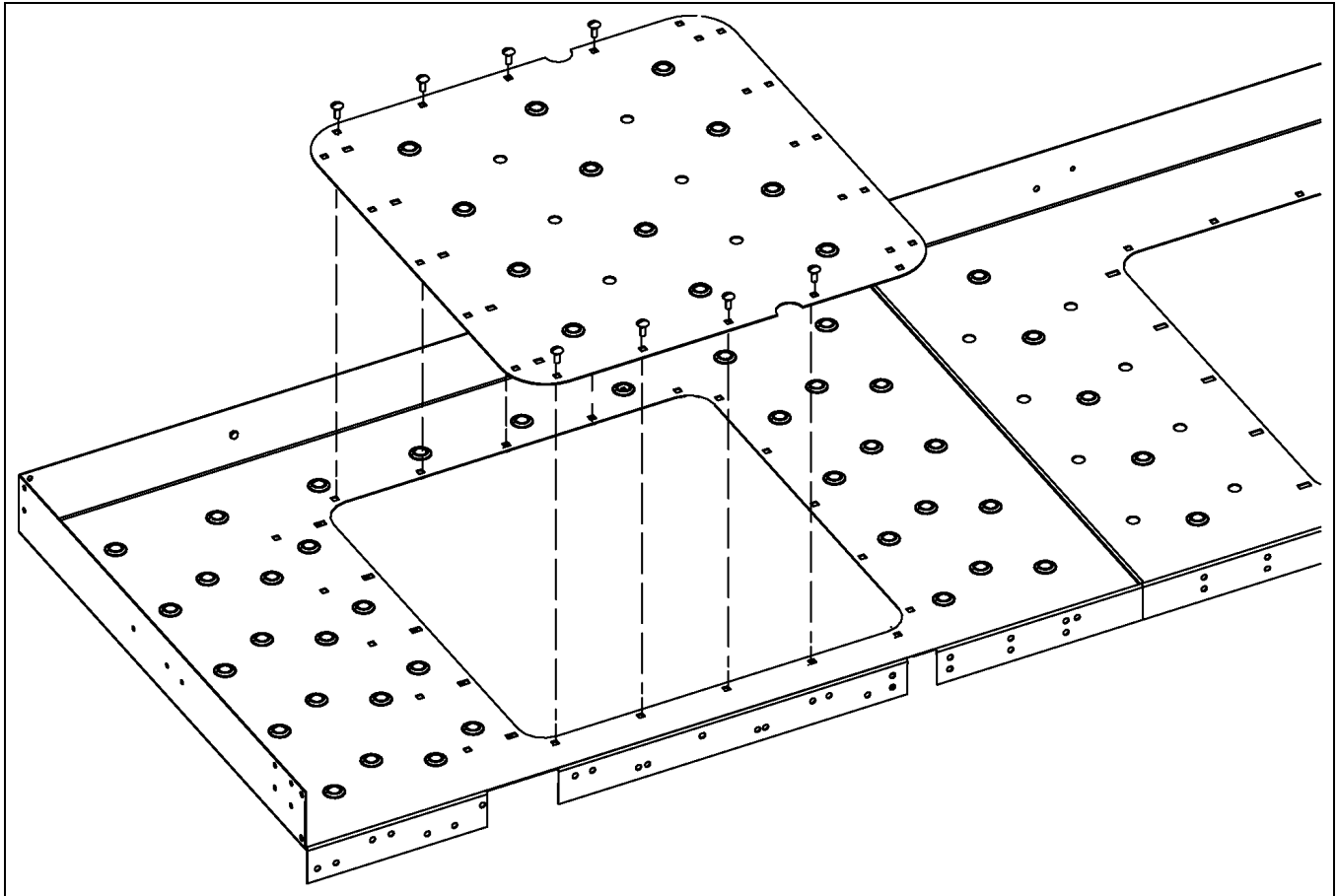

Figure 8F Hatch at Up-Leg End

Slide/Place Toe Boards on Cross Deck Support Channels

NOTE: Due to the snug fit, you should slide the toe boards in place before placing and securing Deck A or any subsequent decking.

1. On the non-drive side slide one toe board (HP36STBX) (B) into place.
2. On the drive side slide one toe board (HP36STBX) (B) into place. (See Figure 8G.)

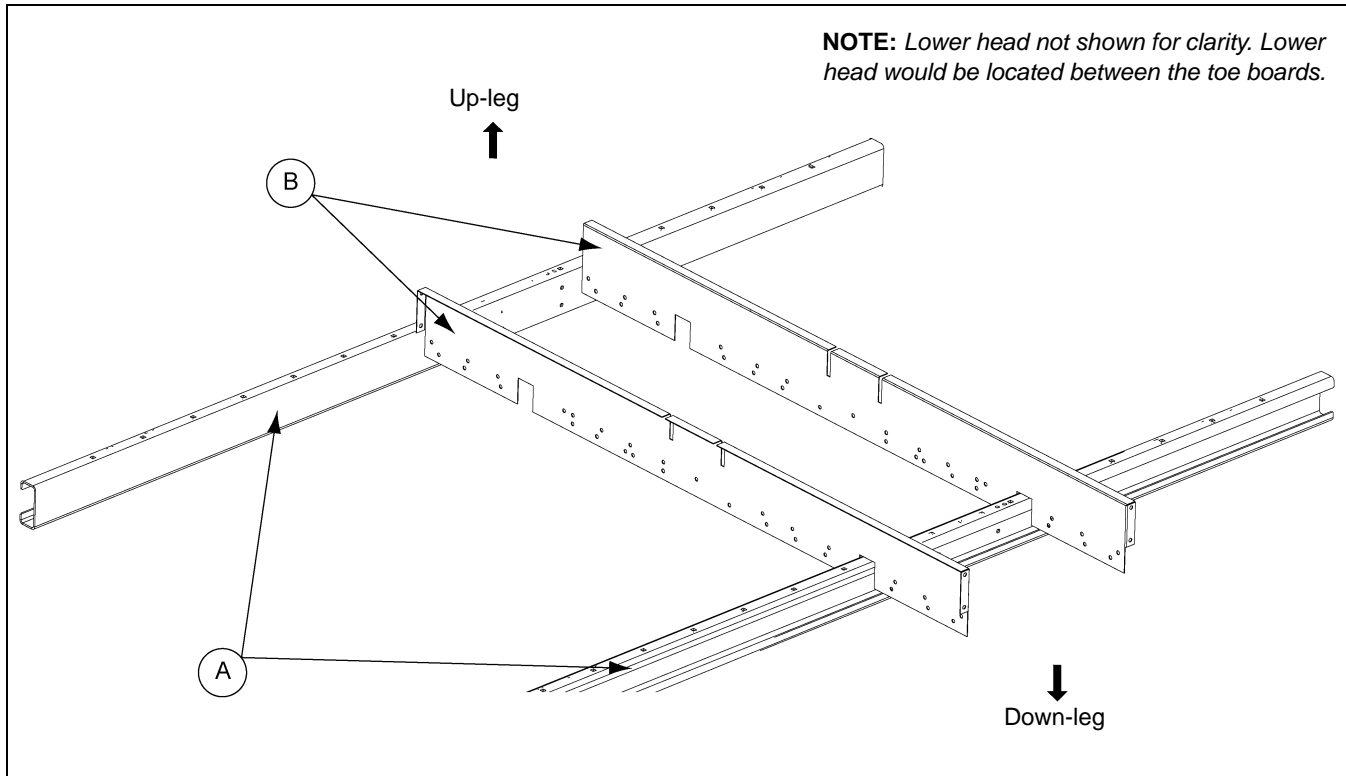

Figure 8G

Ref #	Part #	Description
A	HP36CDSCX	Cross Deck Support Channels
B	HP36STBX	Toe Boards

8. 30"-36" Head Platform Right Hand Drive

Connect Deck A to Cross Deck Support Channels and Toe Board

NOTE: Orientation of etched holes on deck and channel is critical to subsequent steps. Connect all bolts only finger tight until deck is completely assembled and then tighten to proper torque.

1. Locate pre-assembled Deck A. This plank consists of the hatch opening and the hatch cover plate.
2. Orient Deck A so the hatch opening is at discharge end of lower head and hatch cover plate is at up-leg end.
3. At the **Discharge End**, use a punch as needed to line up. (See Figure 8H.)
 - a. For 36" - Deck hole **A1** and channel hole **X1**.
 - b. For 36" - Deck hole **A7** to channel hole **X2**.
 - c. For 30" - Deck hole **A1** and channel hole **Y1**.
 - d. For 30" - Deck hole **A7** to channel hole **Y2**.
 - e. For both 30" and 36" - Deck hole **A2** to toe board hole **A2**. (See Figure 8I on Page 59.)

NOTE: At this time, the head platform hatch deck support (HP36HDS) (D) should be installed **UNDER** Deck A. Line this up with hole **A12** on the deck flange near hatch opening and install at the same time attaching deck to toe board. (See Figure 8I on Page 59.)

4. At the **Up-Leg End** for both 30" and 36", use a punch to align:
 - a. Channel hole **Y1** to corner hole of hatch cover plate.
 - b. Deck hole **A4** to toe board hole **A4**. (See Figure 8I on Page 59.)
5. Connect holes as described above, connect all holes between support channel and Deck A.

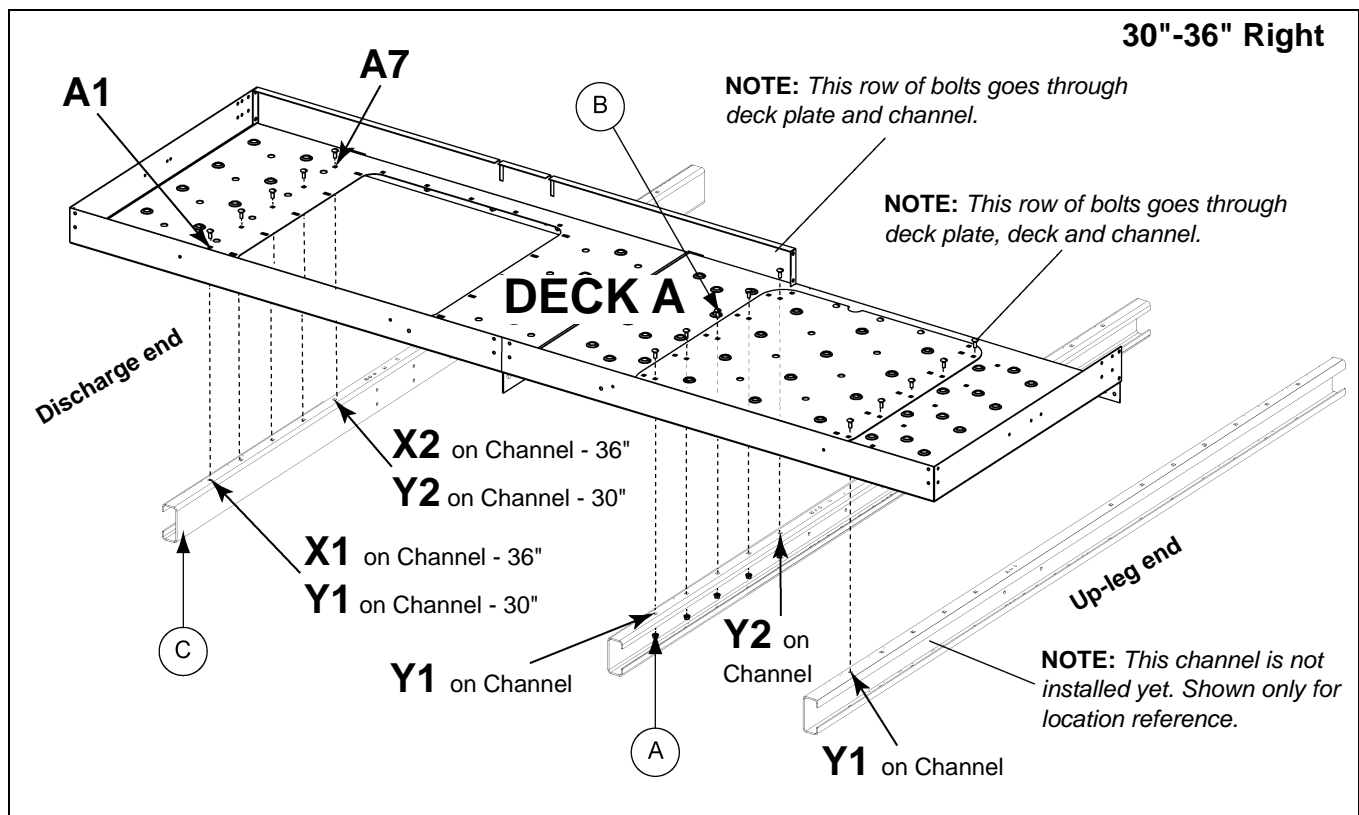

Figure 8H

8. 30"-36" Head Platform Right Hand Drive

Ref #	Part #	Description
A	S-10028	3/8" Flange Nut
B	S-3585	3/8" x 1" Carriage Bolt
C		For 30" this channel is facing the same as the other two (2) channels, "Y" side up. Bolt holes are in same location.

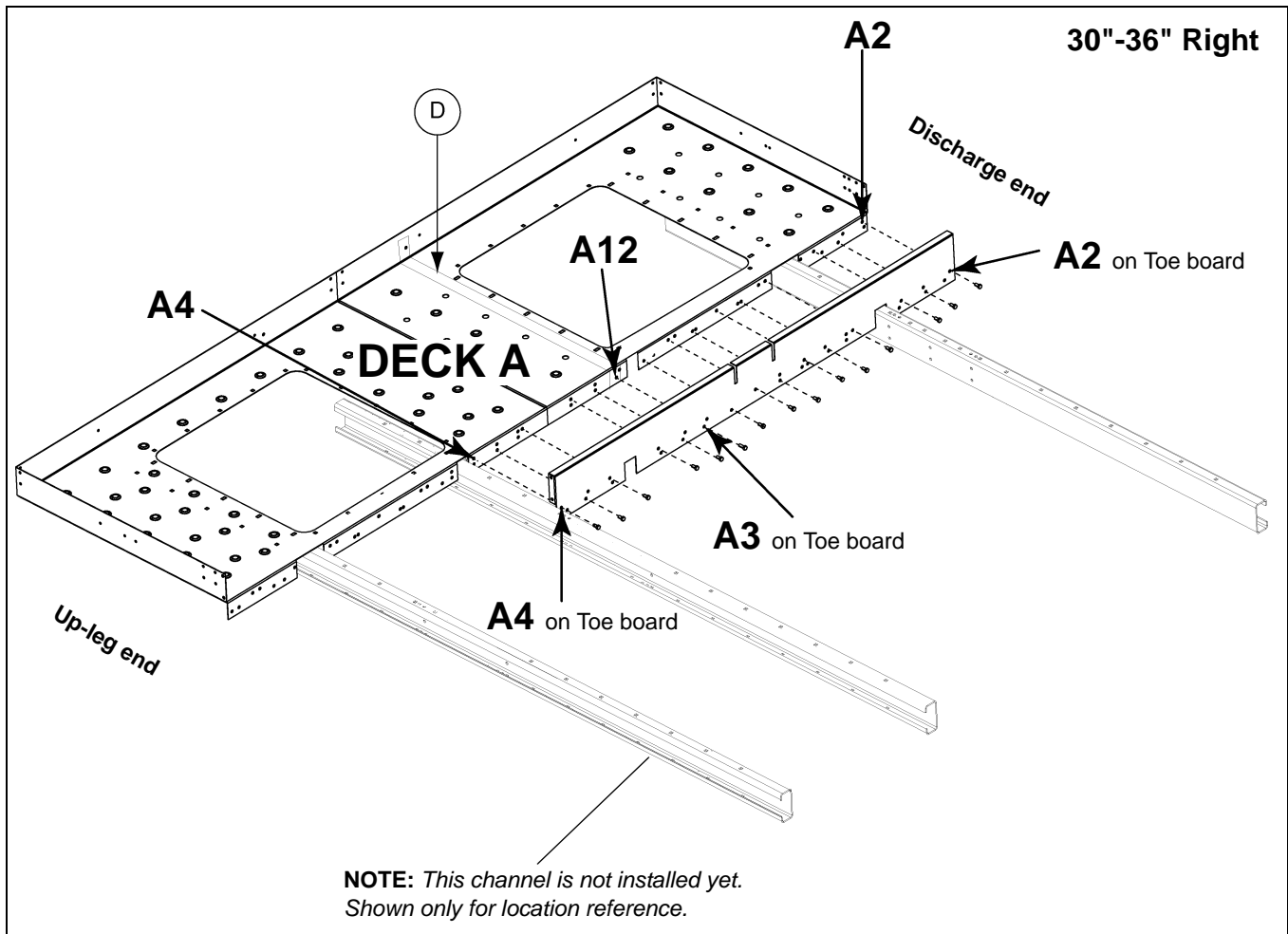

Figure 8I

Ref #	Part #	Description
D	HP36HDS	Install Head Platform Hatch Deck Support

8. 30"-36" Head Platform Right Hand Drive

Connect Deck C to Cross Deck Support Channel and to Toe Board

NOTE: The orientation of the flanges on Deck C is critical to subsequent steps. Tighten bolts only finger tight until deck alignment is complete.

1. Locate the pre-assembled Deck C. This deck consists of two (2) planks.
2. Orient Deck C with hole **C3** at the discharge end of the lower head.
3. Make sure the extended kick plate flange of Deck C is away from the lower head assembly. *(See Figure 8J below and Figure 8K on Page 61.)*
4. Align holes. Use a punch as needed to line up the holes:
 - a. **For 36"** - Deck hole **C3** and channel hole **X5** at discharge end.
 - b. **For 30"** - Deck hole **C3** and channel hole **Y5** at discharge end.
5. Connect cross deck support channel and Deck C using 3/8" x 1" carriage bolts (S-3585) with flange nuts (S-10028). Connect all holes between channel and deck. *(See Figure 8J.)*
6. Align and connect Deck C to toe board using 3/8" x 1" bolts (S-7469) with flange nuts (S-10028).
 - a. Deck hole **C1** to toe board hole **A4**.
 - b. Deck hole **C2** to toe board hole **A2**.

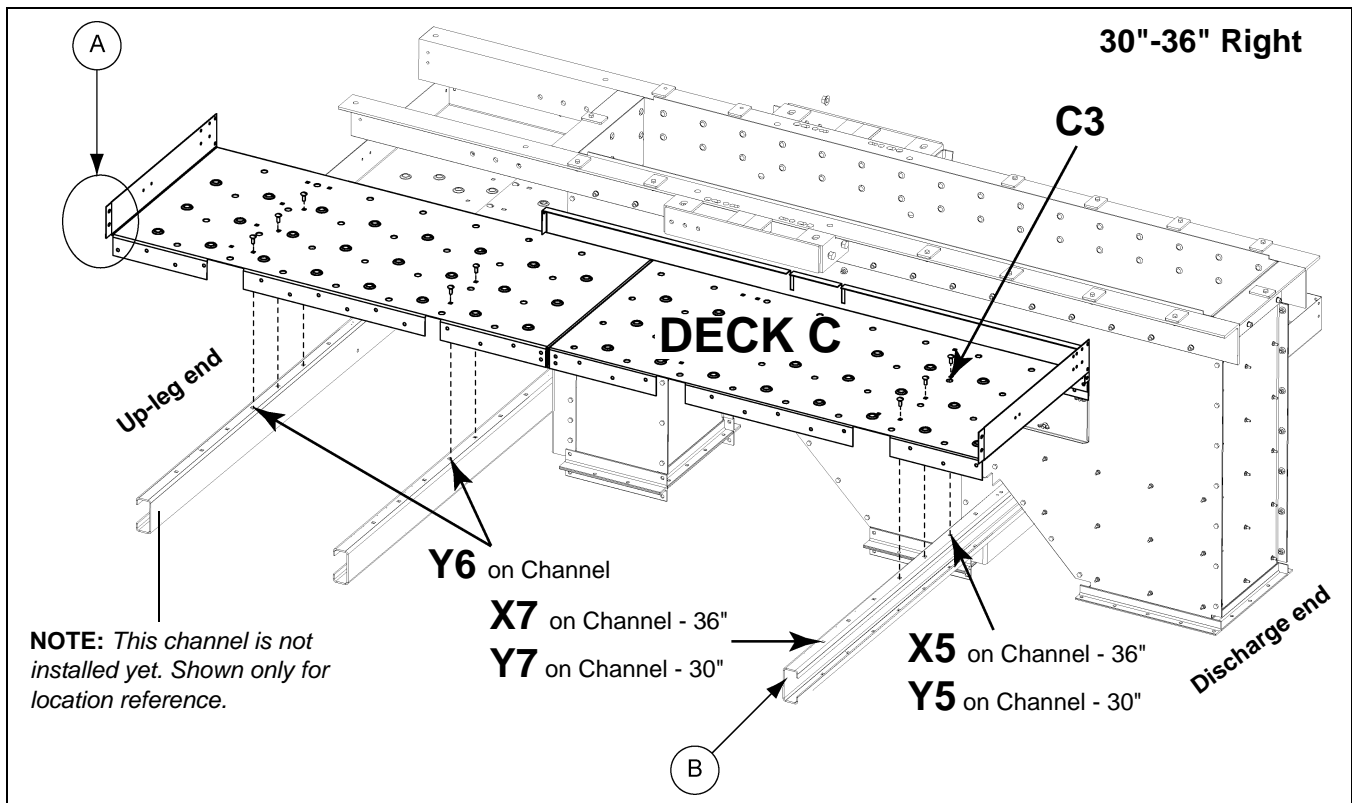

Figure 8J Deck C to Cross Deck Support Channels

Ref #	Description
A	Note Direction of Flange
B	For 30" this channel is facing the same as the other two (2) channels, "Y" side up. Bolt holes are in same location.

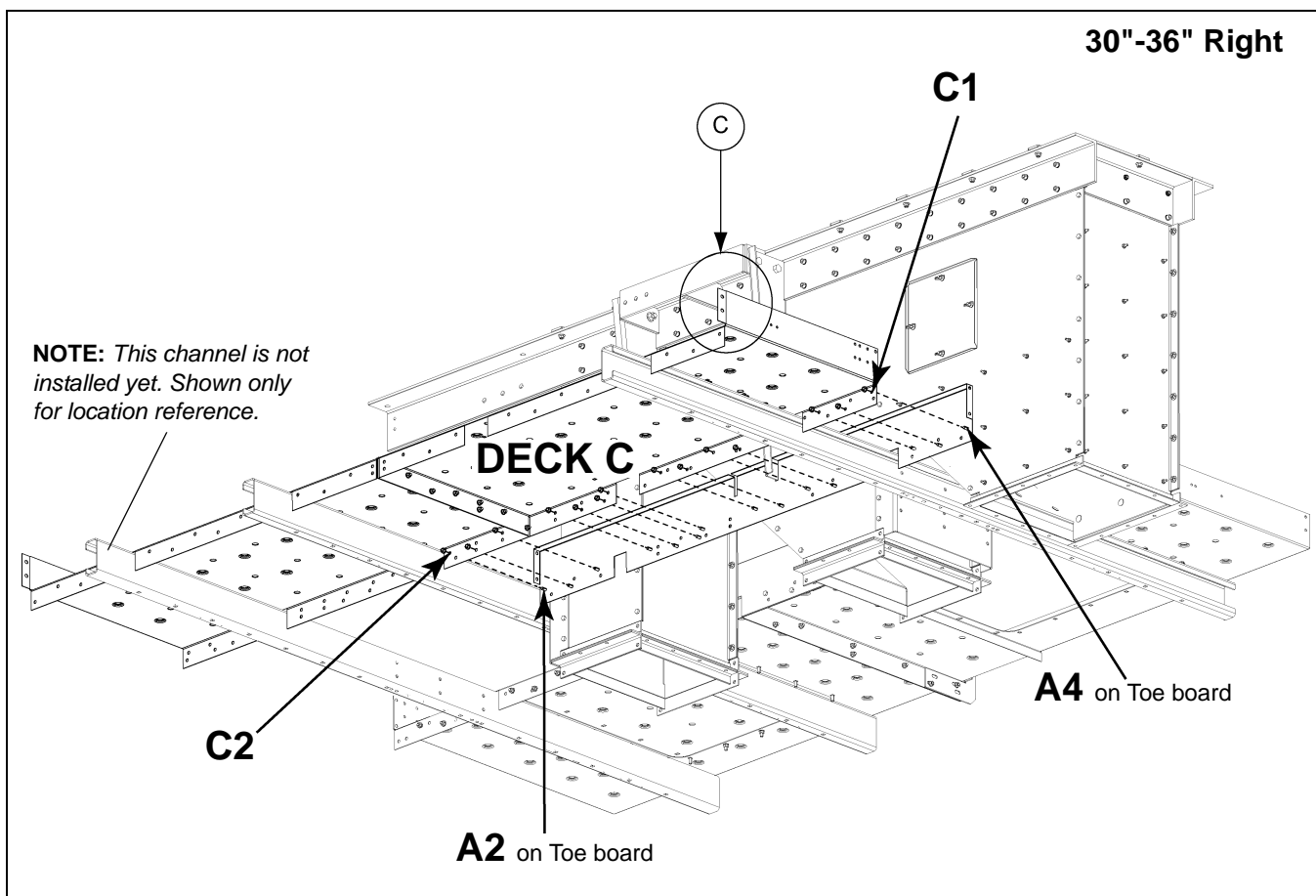

Figure 8K Underside View of Deck C to Toe Board

Ref #	Description
C	Note Direction of Flange

8. 30"-36" Head Platform Right Hand Drive

Connect Deck F to Cross Deck Support Channels and Deck C

IMPORTANT: Connect all bolts only finger tight until deck is completely assembled and then tighten to proper torque.

1. Locate pre-assembled Deck F. This deck consists of two (2) planks.
2. Orient Deck F with hole **F3** at the discharge end of the lower head and **F5** at the up-leg end. *(See Figure 8L.)*
3. Align holes. Use a punch as needed to line up the holes:
 - a. **For 36"** - Deck hole **F3** and channel hole **X7**.
 - b. **For 30"** - Deck hole **F3** and channel hole **Y7**.
 - c. **For 30" and 36"** - Deck hole **F5** and channel hole **Y7**.
4. Connect deck to channel using 3/8" x 1" carriage bolts (S-3585) with flange nuts (S-10028).
5. Orient Deck F flange outside of Deck C flange. *(See Figure 8N on Page 63.)*

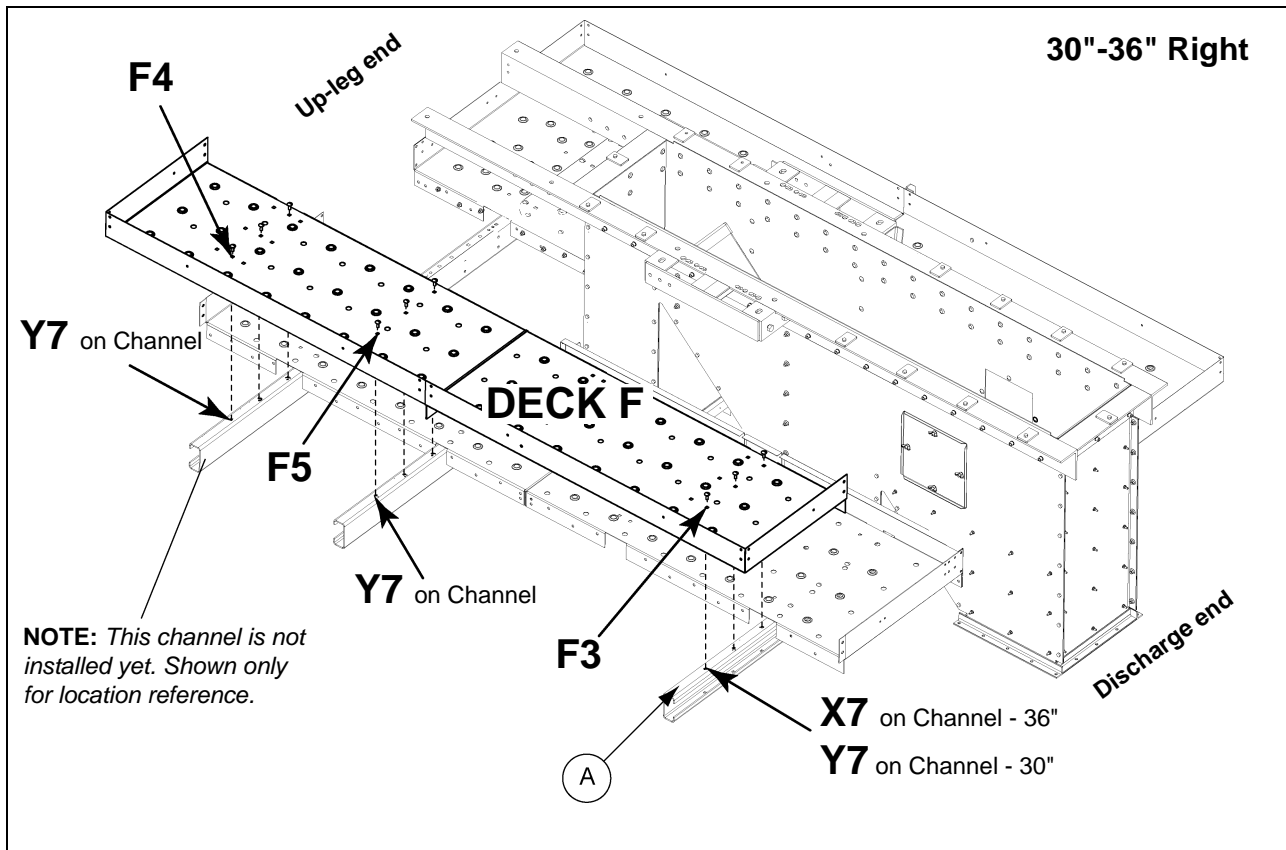

Figure 8L Deck F to Cross Deck Support Channel

Ref #	Description
A	For 30" this channel is facing the same as the other two (2) channels, "Y" side up. Bolt holes are in same location.

8. 30"-36" Head Platform Right Hand Drive

6. Connect Deck F to Deck C using 3/8" x 1" bolts (S-7469) with flange nuts (S-10028).
 - a. Align F Deck hole **F2** to C deck hole **C6**.
 - b. Align F Deck hole **F1** to C deck hole **C7**. (See Figure 8M.)

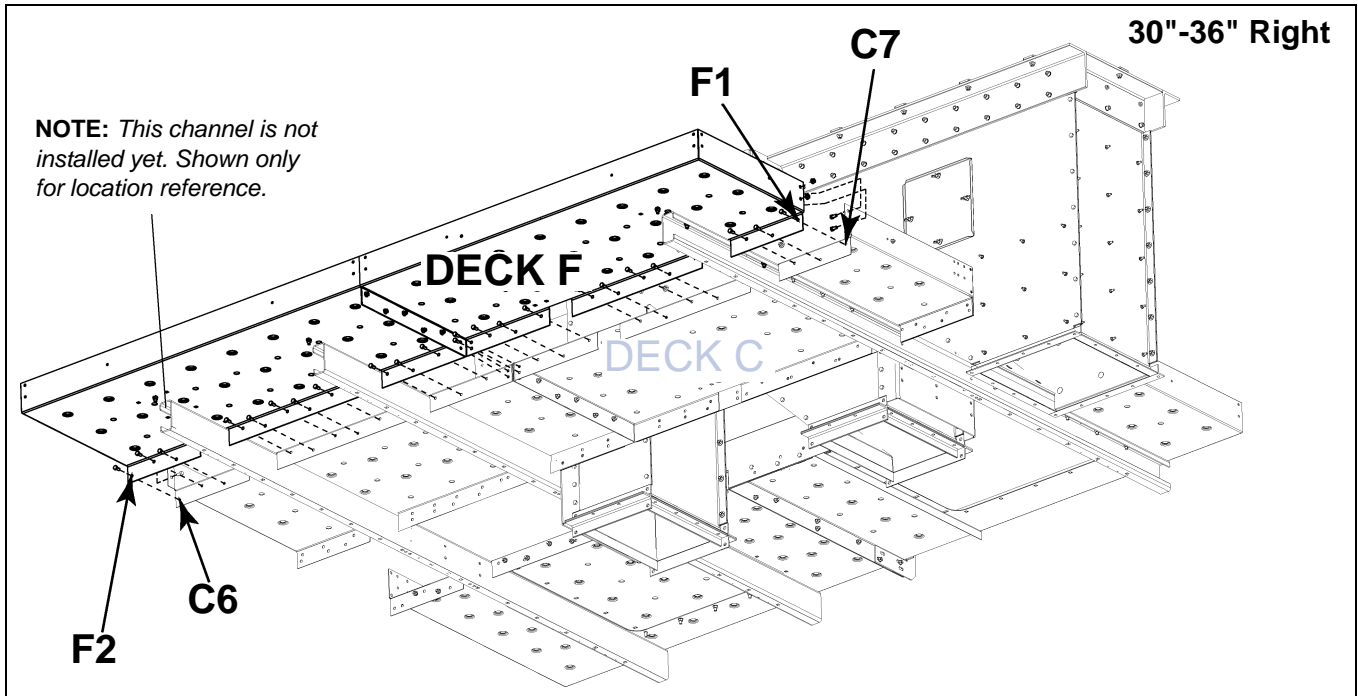

Figure 8M Deck F to Deck C

7. Install the head platform hatch deck support (HP1648HDS) (B) under Deck C and Deck F using 3/8" x 3/4" bolt (S-7105) and nut. (See Figure 8N.) **NOTE:** You may need to remove a bolt from the toe board if one was installed in this location.

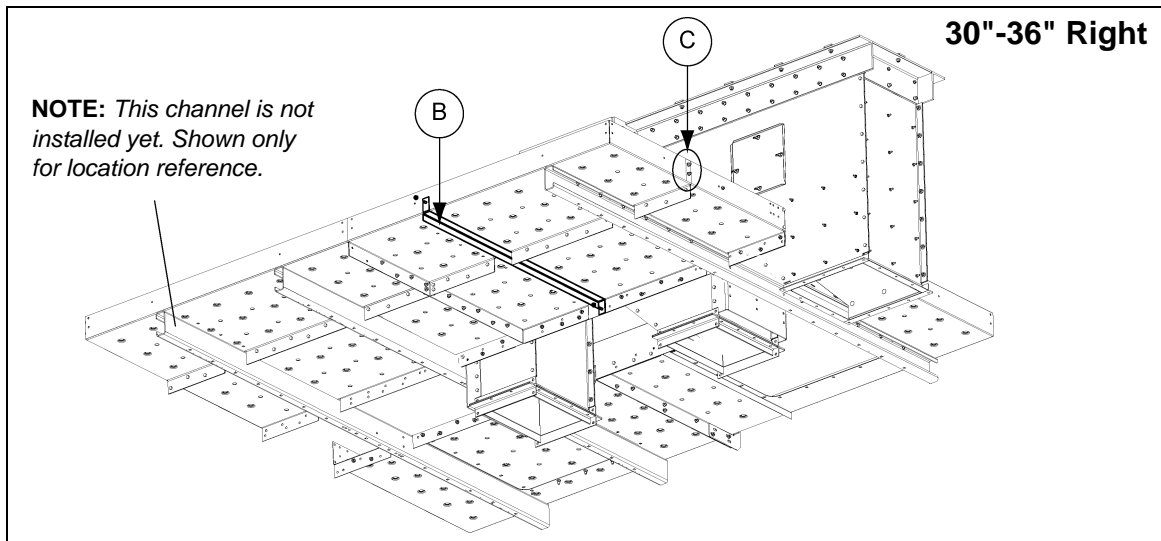

Figure 8N

Ref #	Part #	Description
B	HP1648HDS	HP Hatch Deck Support
C		Deck F Flange on Outside of Deck C Flange

8. 30"-36" Head Platform Right Hand Drive

Attach Third Cross Deck Support Channel to Decking

Connect all bolts only finger tight until deck is completely assembled and then tighten to proper torque.

1. Orient channel: Locate the third cross deck support channel (HP36CDSCX) and orient it so the "Y" side faces up and hole **Y1** is on the non-drive side of the lower head assembly.
2. Align holes. Use a punch as needed to line up the holes accordingly:
 - a. At the **drive side** - channel hole **Y7** on the cross deck support channel to deck hole **F4**. (See Figure 8L on Page 62.)
 - b. At the **hatch side** - channel hole **Y1** on the cross deck support channel to Deck A and deck plate cover. (See Figure 8H on Page 58.)
 - c. Connect Deck F to support channels using 3/8" x 1" carriage bolts (S-3585) with flange nuts (S-10028). Connect all holes between channel and deck.

Attach Deck E to Deck A, Deck C and Cross Deck Support Channel

NOTE: Connect all bolts only finger tight until deck is completely assembled and then tighten to proper torque.

1. Place Deck E between Deck A and Deck C. (See Figure 80.)
2. Align holes. Use a punch as needed to align deck holes **E5** with channel hole **Y4**. This will align Deck E with holes on each channel.
3. Connect Deck E to cross deck support channels using 3/8" x 1" carriage bolts (S-3585) with flange nuts (S-10028). Connect all holes between channels and deck.
4. Connect the Deck E kick plate flanges to toe boards and flanges of Deck A and Deck C using 3/8" x 3/4" bolts (S-7105) and 3/8" nuts (S-10028). (See Figure 80.)

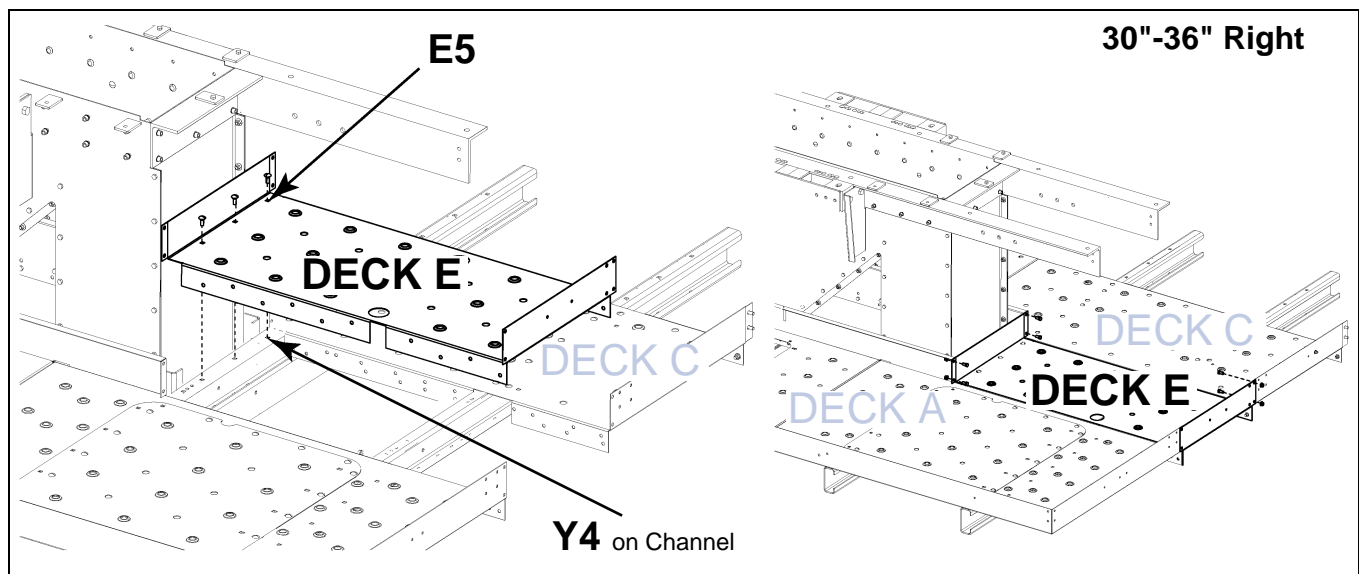

Figure 80

8. 30"-36" Head Platform Right Hand Drive

5. Connect Deck E to Deck A and Deck C using 3/8" x 3/4" bolts (S-7105) with flange nuts (S-10028).
(See Figure 8P.)
 - a. A Deck hole **A5** to E deck hole **E1**.
 - b. A Deck hole **A6** to E deck hole **E2**.
 - c. C Deck hole **C5** to E deck hole **E3**.
 - d. C Deck hole **C4** to E deck hole **E4**.



After decking is completely assembled, make sure to go back and tighten all bolts and nuts to the proper torque rating.

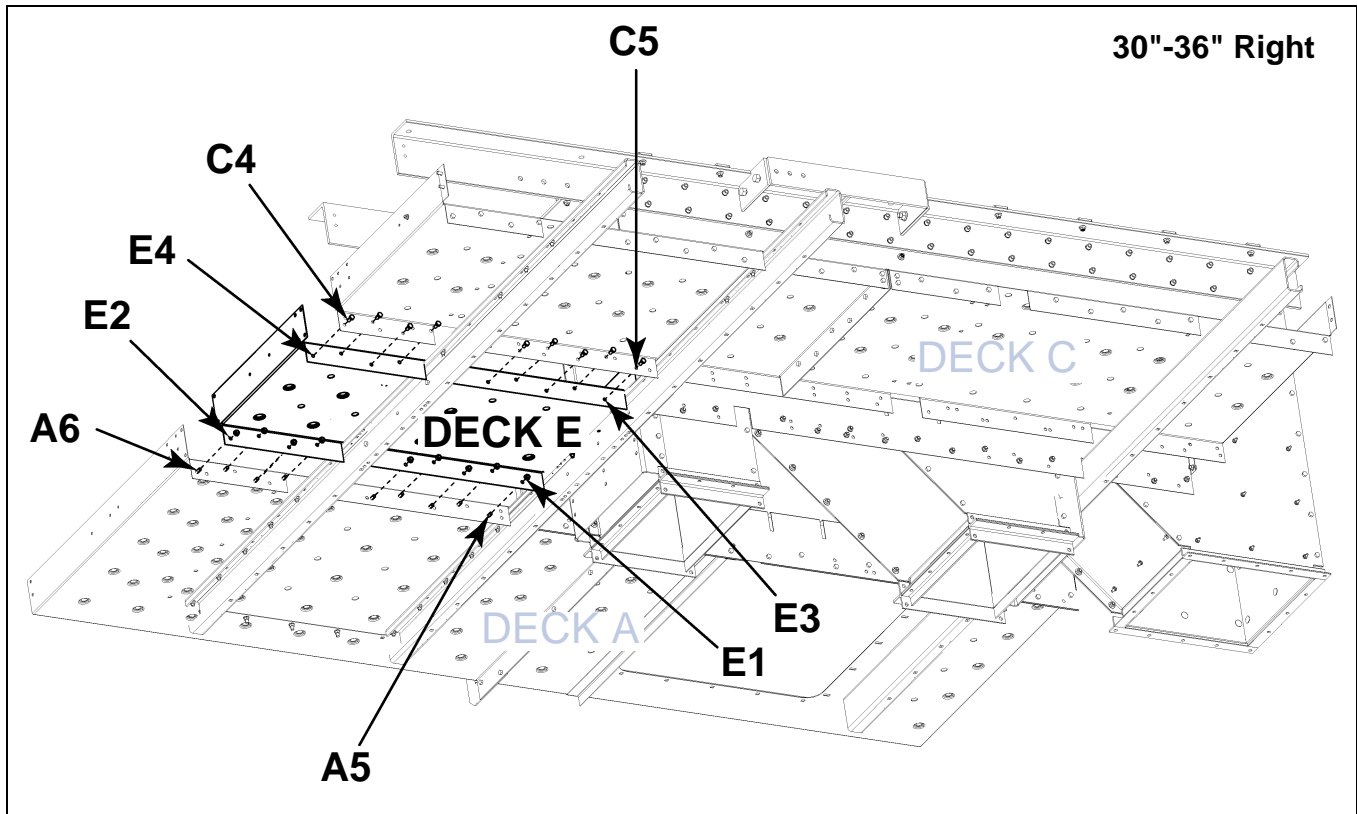

Figure 8P

Chapter 9: 30"-36" Head Platform Left Hand Drive

To facilitate quick and easy assembly, numerous parts are pre-assembled prior to shipping.

Considerable time is dedicated at the beginning of this manual to the proper orientation of channels and decks. This is because the orientation of these elements is essential to the proper construction of the head platform.

1. There are many ways to get the orientation wrong and only one way to get it right.
2. Proper orientation of the channels and decks is essential proper assembly.
3. Proper construction of the head platform can only be completed if the initial orientation of the channels is done correctly.

Therefore, we strongly advise you take time to confirm that the orientation of these early elements is correct before you begin to assemble the decking on to the channels.

To facilitate proper connections, major connecting holes are etched with alpha-numeric codes.

- One side is labeled **X1** through **X7**, this side is referred to as the “**X**” side.
- The opposite side is labeled with **Y1** through **Y7** and is referred to as the “**Y**” side.

Attach Cross Deck Support Channels to Lower Head

Three (3) cross deck support channels support the platform. Two (2) of the channels are attached to brackets on the lower head section and the third channel is attached to the decking itself but is not attached directly to the lower head. This third channel will be attached after the deck is assembled. (See Figure 9A.)

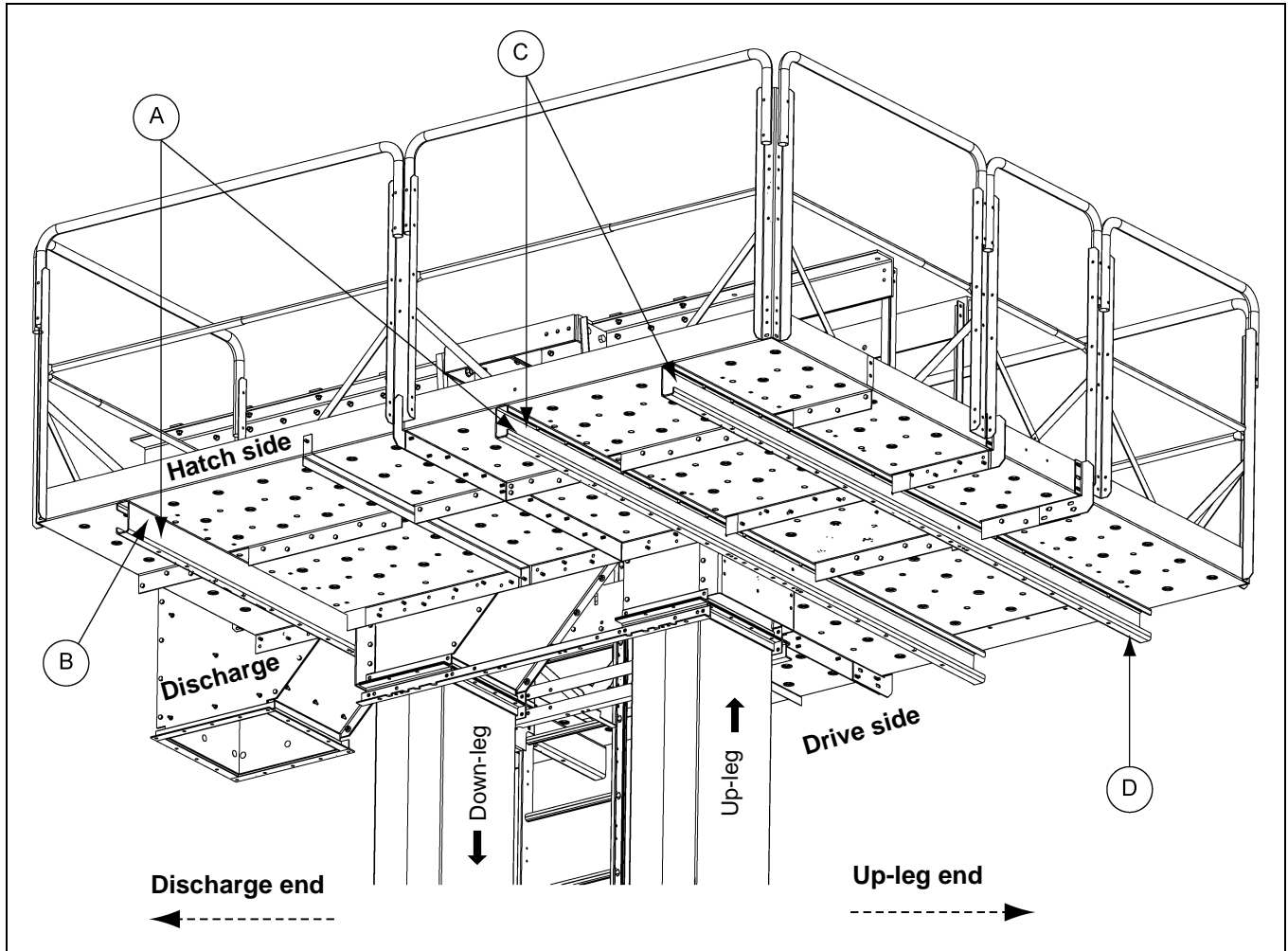

Figure 9A Left Platform Overview

Ref #	Description
A	These cross deck support channels connect directly to bracket on the lower head.
B	Channels "X" side up ("X1" starts here)
C	Channels "Y" side up ("Y1" starts here)
D	This channel is installed later, after the decking has been assembled.

NOTE: The difference between left and right. The only difference is the channel orientation as they attach to the lower head brackets. This makes you swap Deck A with the positions of Deck C and Deck F.

For 30" Left Side Drive

Orient the Channel

1. At **Discharge End** orient the channel so that:
 - a. Channel opening is outward, toward the discharge end of the head.
 - b. Holes labeled with "X" face up.
 - c. Hole **X1** is on the non-drive side of the lower head.
 - d. Hole **X7** is on the drive side of the lower head.
 - e. Cross deck support channel extends farther on the drive side than on hatch side of lower head.
 2. At **Up-Leg End** orient the channel so that:
 - a. Channel opening outward, toward the up-leg end of the head.
 - b. Holes labeled with "X" face up.
 - c. Hole **X1** is on the non-drive side of the lower head.
 - d. Hole **X7** is on the drive side of the lower head.
 - e. Cross deck support channel extends farther on the drive side than on hatch side of lower head.
(See Figure 9B on Page 69.)
 3. Attach cross deck support channels (HP36CDSCX) to the top-most set of holes of the lower head brackets (HSP36130) using 3/8" x 1" bolts and nuts. *(See Figure 9C on Page 69.)*
- *NOTE:** *The channels MUST be oriented as shown in Figure 9B and Figure 9C on Page 69 in order for the decking and subsequent assembly to be done correctly.*

9. 30"-36" Head Platform Left Hand Drive

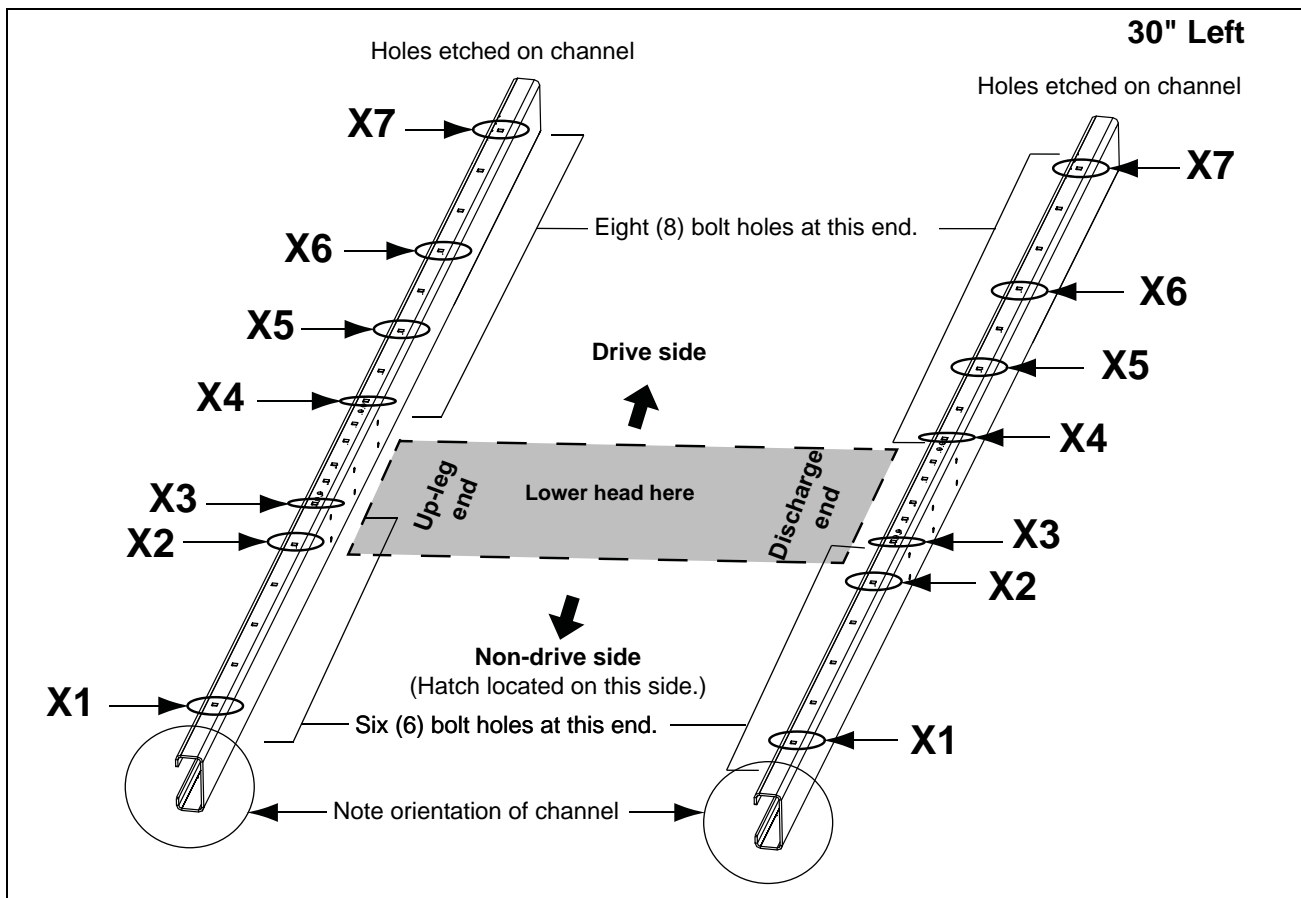

Figure 9B 30" Left Side Drive Channel Position

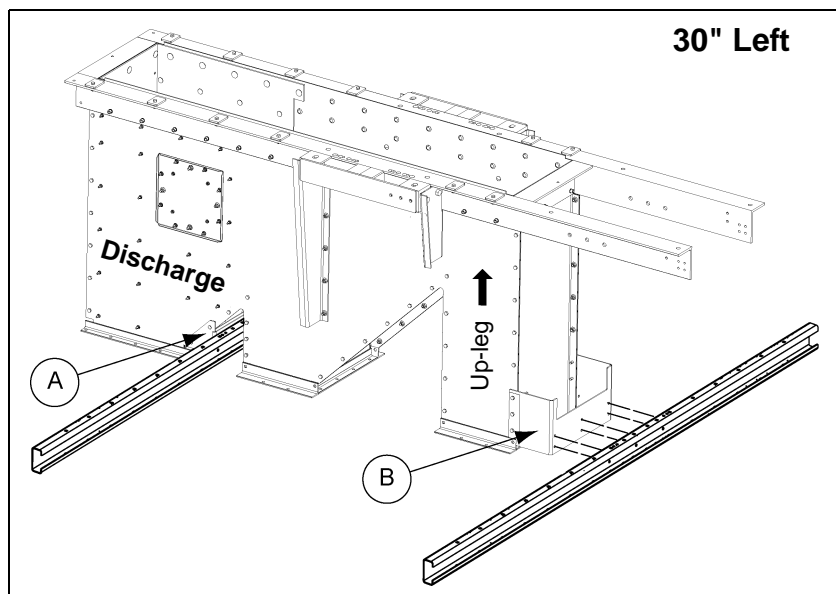

Figure 9C 30" Left Drive - Cross Deck Support Channels to Lower Head Brackets

Ref #	Part #	Description
A	HP30XLHPSA	30" HP Lower Head Discharge Bracket
B	HP30XLHPS	30" HP Lower Head Bracket

For 36" Left Side Drive

Orient the Channel

1. At **Discharge End** orient the channel so that:
 - a. Channel opening is outward, toward the discharge end of the head.
 - b. Holes labeled with “Y” face up.
 - c. Hole **Y1** is on the non-drive side of the lower head.
 - d. Hole **Y7** is on the drive side of the lower head.
 - e. Cross deck support channel extends farther on the drive side than on hatch side of lower head.
 2. At **Up-Leg End** orient the channel so that:
 - a. Channel opening outward, toward the up-leg end of the head.
 - b. Holes labeled with “X” face up.
 - c. Hole **X1** is on the non-drive side of the lower head.
 - d. Hole **X7** is on the drive side of the lower head.
 - e. Cross deck support channel extends farther on the drive side than on hatch side of lower head.
(See Figure 9D on Page 71.)
 3. Attach cross deck support channels (HP36CDSCX) (A) to the top most set of holes of the lower head brackets (HSP36130) (B) using 3/8" x 1" bolts and nuts. *(See Figure 9E on Page 71.)*
- *NOTE:** *The channels MUST be oriented as shown in Figure 9D and Figure 9E on Page 71 in order for the decking and subsequent assembly to be done correctly.*

9. 30"-36" Head Platform Left Hand Drive

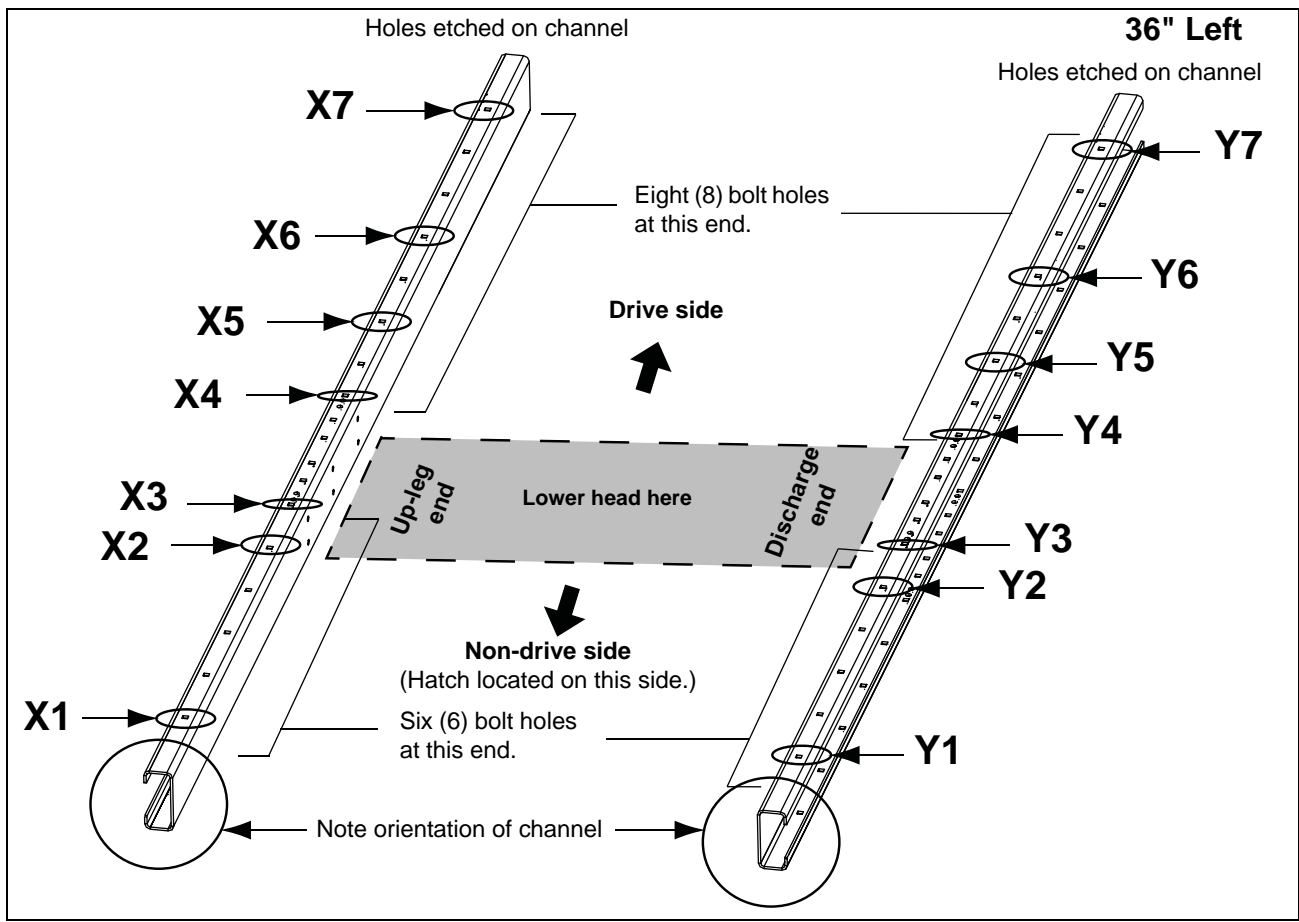

Figure 9D 36" Left Side Drive Channel Position

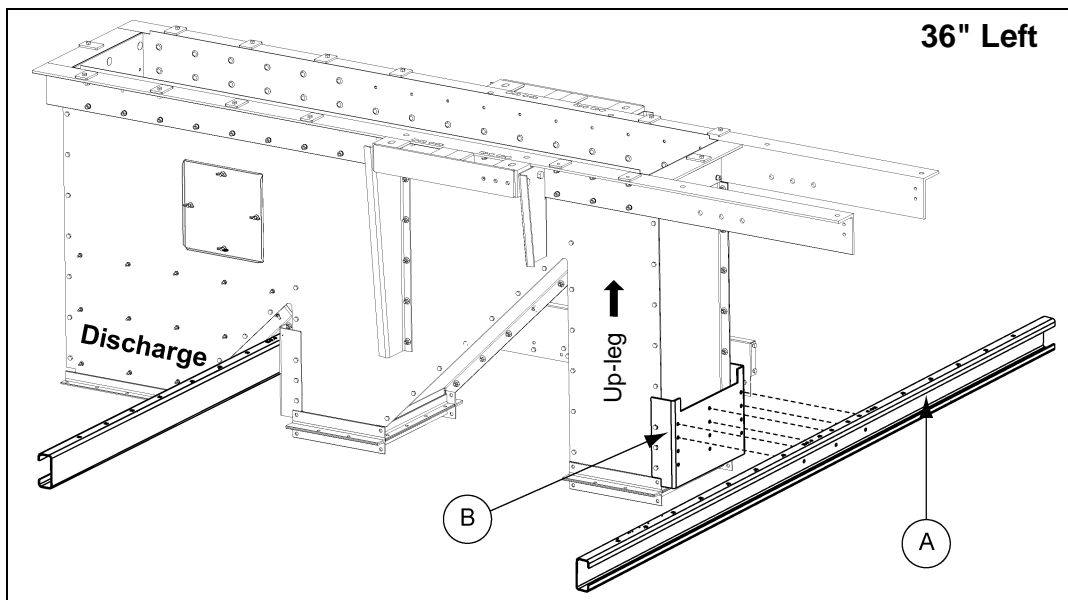

Figure 9E

Ref #	Part #	Description
A	HP36CDSCX	Cross Deck Support Channel
B	HSP36130	Lower Head Bracket

Attach Deck A to Hatch Cover Plate

NOTE: Only two (2) side of deck plate are attached at this time.

1. **Locate pre-assembled Deck A:** This plank consists of the hatch opening, the hatch filler plate and is labeled with holes etched with the letter A.
2. **Orient Deck A:** The hatch cover plate is at the up-leg end of the deck. The hatch will be located at the discharge end and will remain open at this time. A hatch door will be attached to Deck A later and should NOT be installed at this time
3. **Attach the hatch cover plate to Deck A:** Use eight (8) 3/8" x 1" carriage bolts (S-3585) with flange nuts (S-10028). (See Figure 9F.)

NOTE: ONLY connect the hatch filler plate along two (2) of the four (4) sides of the plate. The holes perpendicular to the length of Deck A should remain open at this time as they will serve to connect the hatch cover plate and deck A to the cross deck support channel.

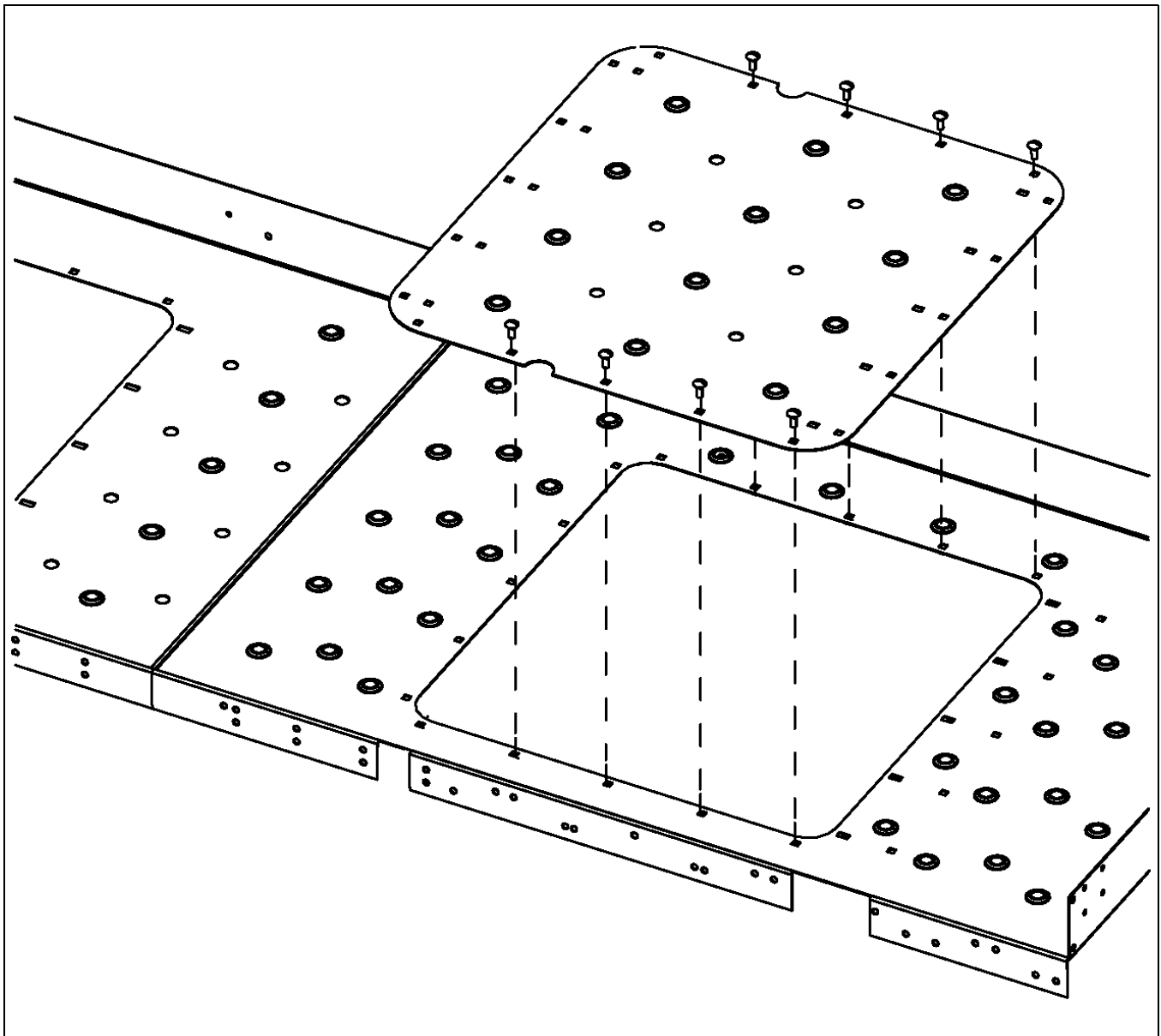

Figure 9F Hatch at Up-Leg End

Slide/Place Toe Boards on Cross Deck Support Channels

NOTE: Due to the snug fit, you should slide the toe boards in place before placing and securing Deck A or any subsequent decking.

1. On the non-drive side slide one toe board (HP36STBX) (B) into place.
2. On the drive side slide one toe board (HP36STBX) (B) into place. (See Figure 9G.)

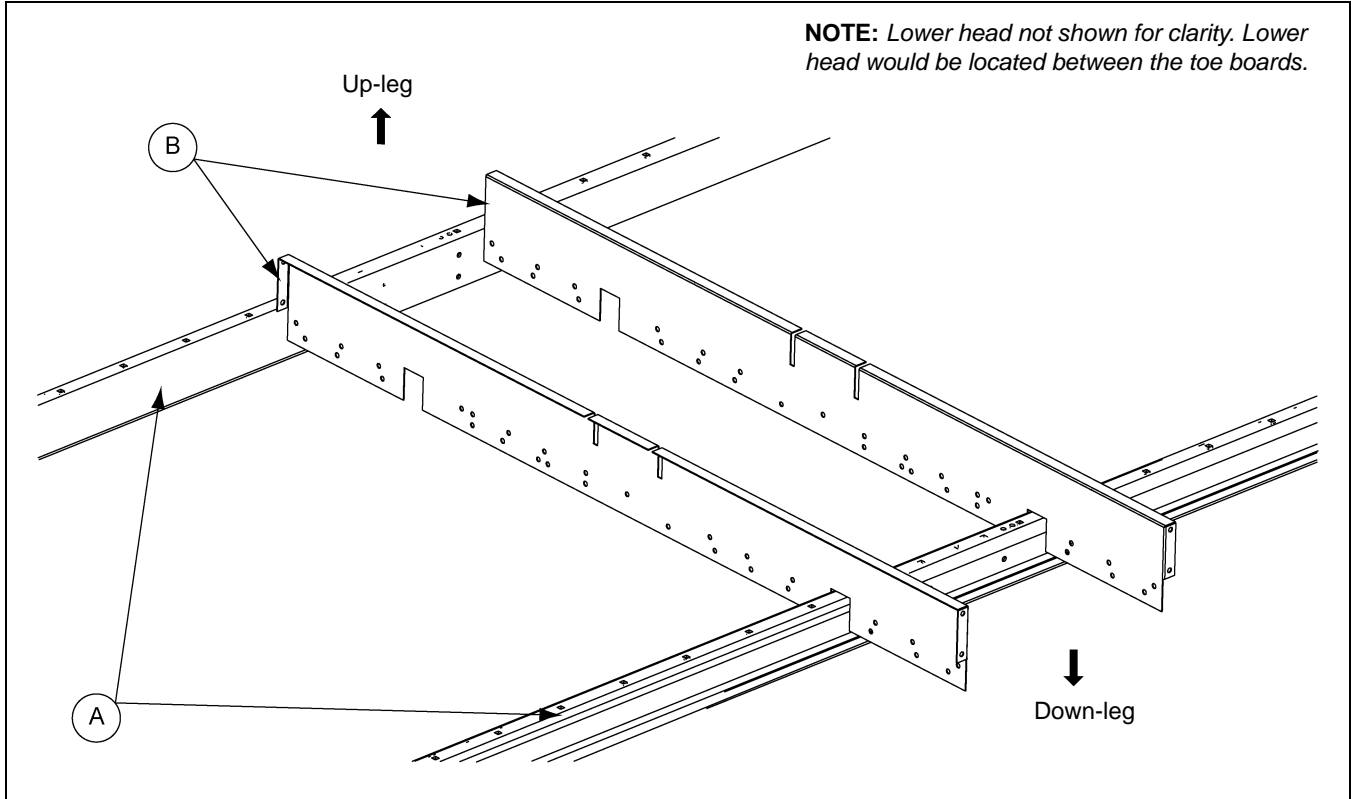

Figure 9G

Ref #	Part #	Description
A	HP36CDSCX	Cross Deck Support Channels
B	HP36STBX	Toe Boards

9. 30"-36" Head Platform Left Hand Drive

Connect Deck A to Cross Deck Support Channels and Toe Board

NOTE: Orientation of etched holes on deck and channel is critical to subsequent steps. Tighten bolts only finger tight until all decking is installed.

1. Locate pre-assembled Deck A. This plank consists of the hatch opening and the hatch cover plate.
2. Orient Deck A so that hatch opening is at discharge end of lower head and hatch cover plate is at the up-leg end.
3. On the **Discharge End**, use a punch as needed to line up. (See Figure 9H.)
 - a. For 36" - Deck hole **A9** and channel hole **Y2**.
 - b. For 30" - Deck hole **A9** to channel hole **X2**.

NOTE: At this time, the head platform hatch deck support (HP36HDS) (C) should be installed **UNDER** Deck A. Line this up with hole **A4** on the deck flange near hatch opening and install at the same time attaching deck to toe board. (See Figure 9I on Page 75.)

4. On the **Up-Leg End** for both 36" and 30", use a punch to align channel hole **X1** to corner hole of hatch cover plate.
5. After aligning the holes as described above, connect all holes between support channel and Deck A using 3/8" x 1" carriage bolts (S-3585) (A) with flange nuts (S-10028) (B).

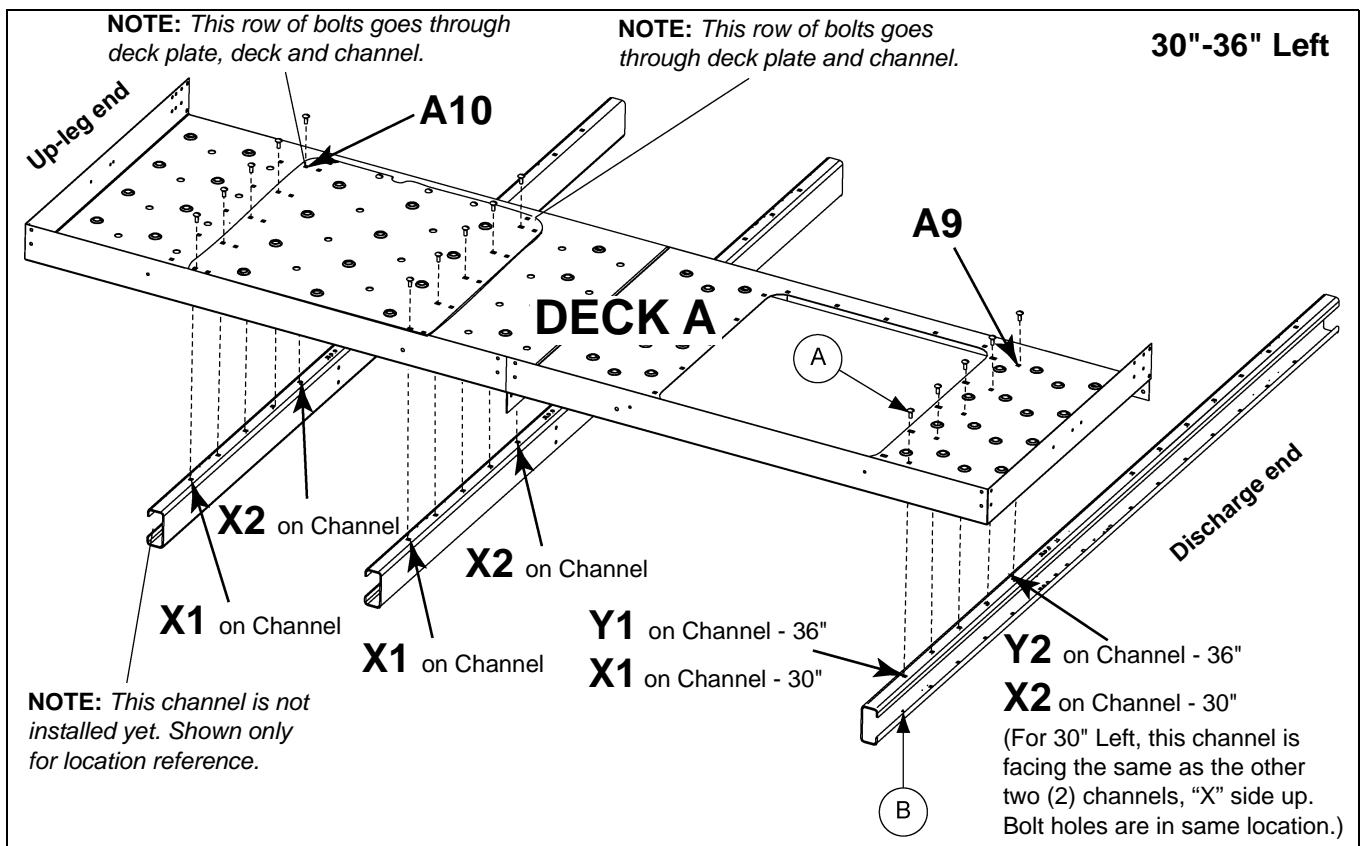

Figure 9H

Ref #	Part #	Description
A	S-3585	3/8" x 1" Carriage Bolt
B	S-10028	3/8" Flange Nut

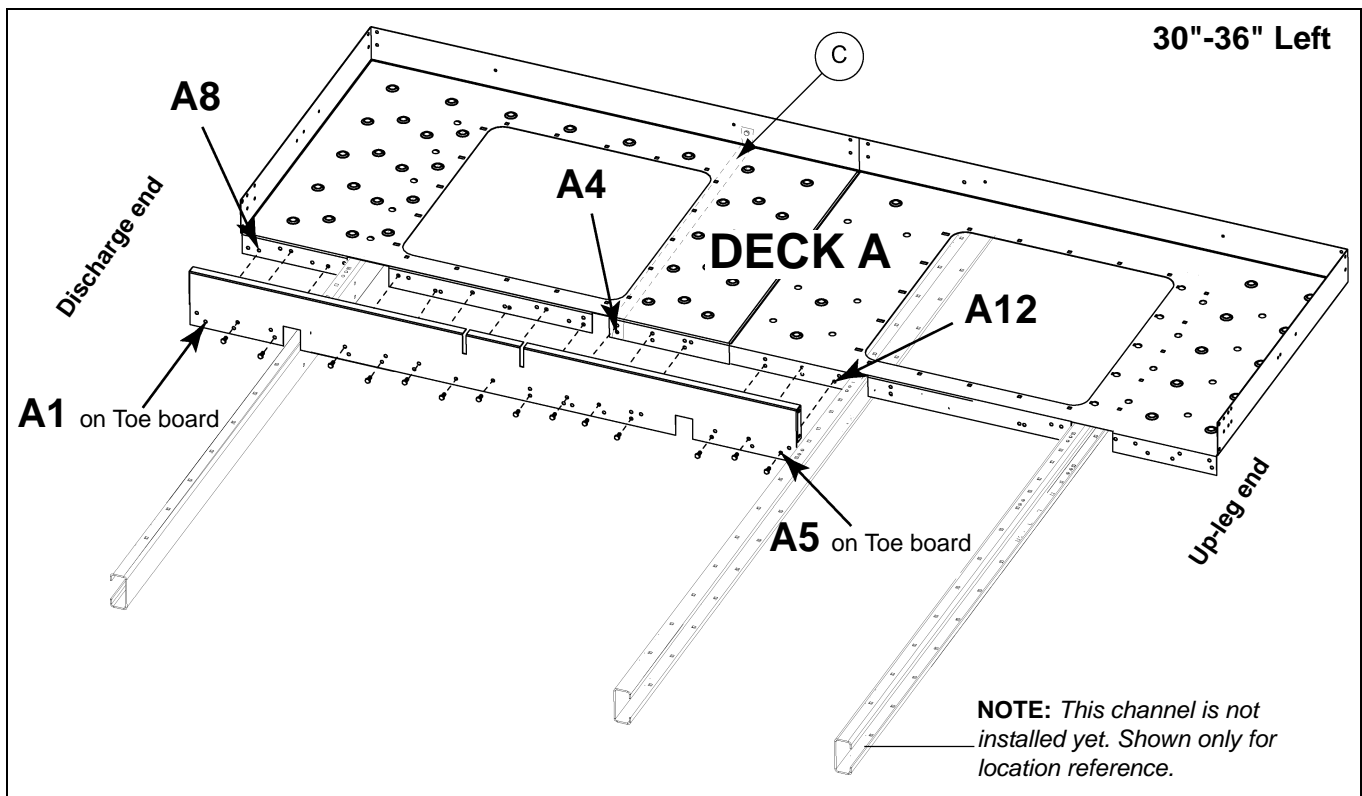

Figure 9I

Ref #	Part #	Description
C	HP36HDS	Head platform hatch deck support installed under deck plate at same time as toe board.

6. **Connect Deck A to Toe Board:** Line up holes on toe board with holes on Deck A:

- a. Deck hole **A8** and toe board hole **A1**.
- b. Deck hole **A12** to toe board hole **A5**.

Connect Deck C to Cross Deck Support Channel and to Toe Board

NOTE: The orientation of the flanges on Deck C is critical to subsequent steps. Tighten bolts only finger tight until deck alignment is complete.

1. Locate the pre-assembled Deck C. This deck consists of two (2) planks.
2. Orient Deck C with hole **C10** at the discharge end of the lower head.
3. Make sure the extended kick plate flange of Deck C is away from the lower head assembly. *(See Figure 9J and Figure 9K on Page 76.)*
4. On the **Discharge End**, use a punch as needed to line up holes:
 - a. **For 36"** - Deck hole **C10** and channel hole **Y6**.
 - b. **For 30"** - Deck hole **C10** to channel hole **X6**.

NOTE: The only difference between the 30" and 36" is the channel on the discharge end would be flipped so the opening of channel is the same as the other two (2) channels for 30".

9. 30"-36" Head Platform Left Hand Drive

5. Connect cross deck support channel and Deck C using 3/8" x 1" carriage bolts (S-3585) with flange nuts (S-10028). Connect all holes between channel and deck.

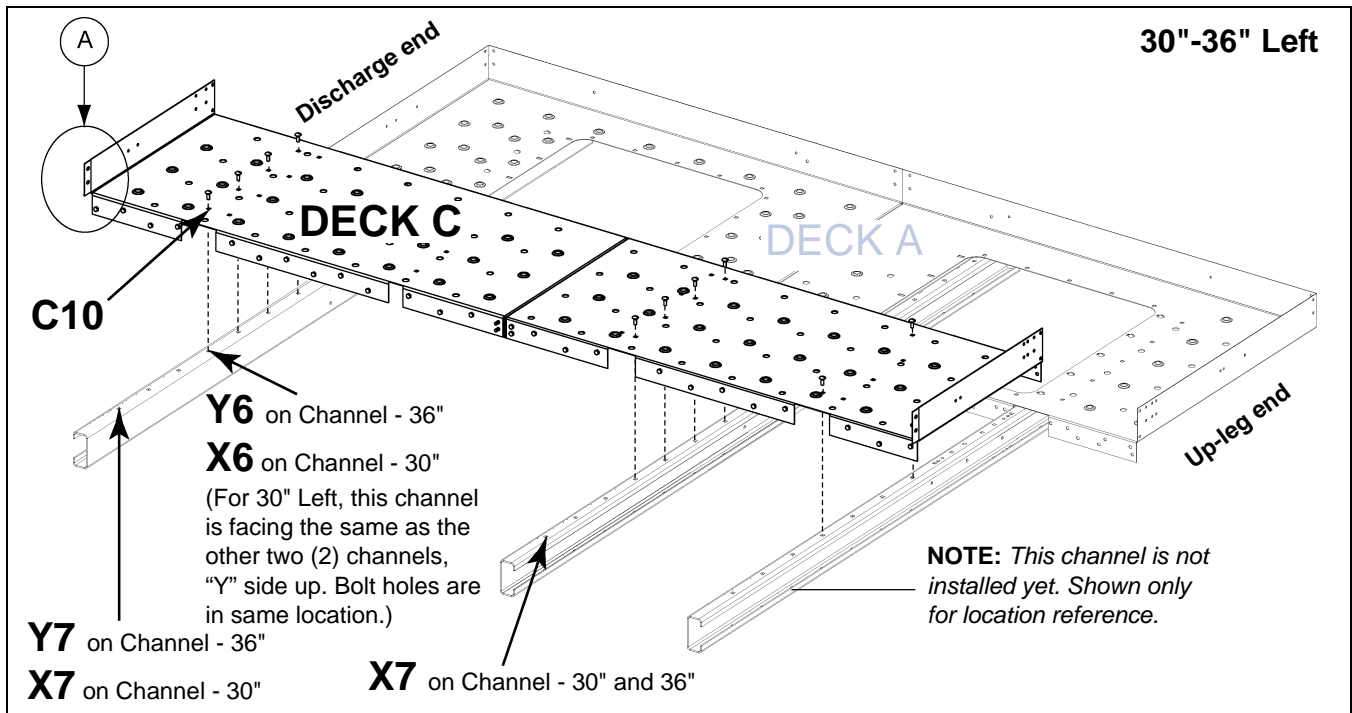

Figure 9J Deck C to Cross Deck Support Channels

Ref #	Description
A	Note Direction of Flange.

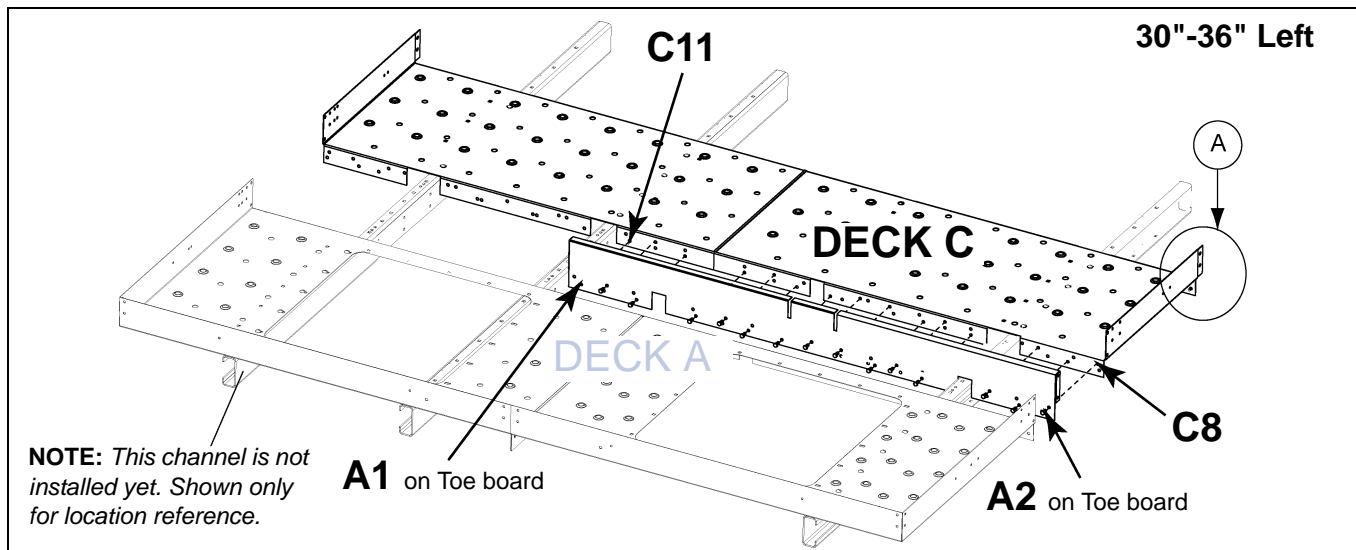

Figure 9K Underside View of Deck C to Toe Board

Ref #	Description
A	Note Direction of Flange

6. Connect Deck C to toe board using 3/8" x 1" bolts (S-7469) with flange nuts (S-10028).
 - a. Deck hole **C11** to toe board hole **A1**.
 - b. Deck hole **C8** to toe board hole **A2**.

Connect Deck F to Cross Deck Support Channels and Deck C

IMPORTANT: Connect all bolts only finger tight until deck is completely assembled and then tighten to proper torque.

1. Locate pre-assembled Deck F. This deck consists of two (2) planks.
2. Orient Deck F with hole **F7** at the discharge end of the lower head and **F6** at the up-leg end. (See Figure 9L.)
3. Align holes. Use a punch as needed to line up the holes:
 - a. Deck hole **F6** and channel hole **X7**.
 - b. Deck hole **F7** and channel hole **Y7**.
4. Connect deck to channel using 3/8" x 1" carriage bolts (S-3585) with flange nuts (S-10028).
5. Orient Deck F flange outside of Deck C flange. (See Figure 9M on Page 78.)
6. Align and connect Deck F to Deck C using 3/8" x 1" bolts (S-7469) with flange nuts (S-10028).
 - a. F Deck hole **F2** to C deck hole **C6**.
 - b. F Deck hole **F1** to C deck hole **C7**. (See Figure 9L.)

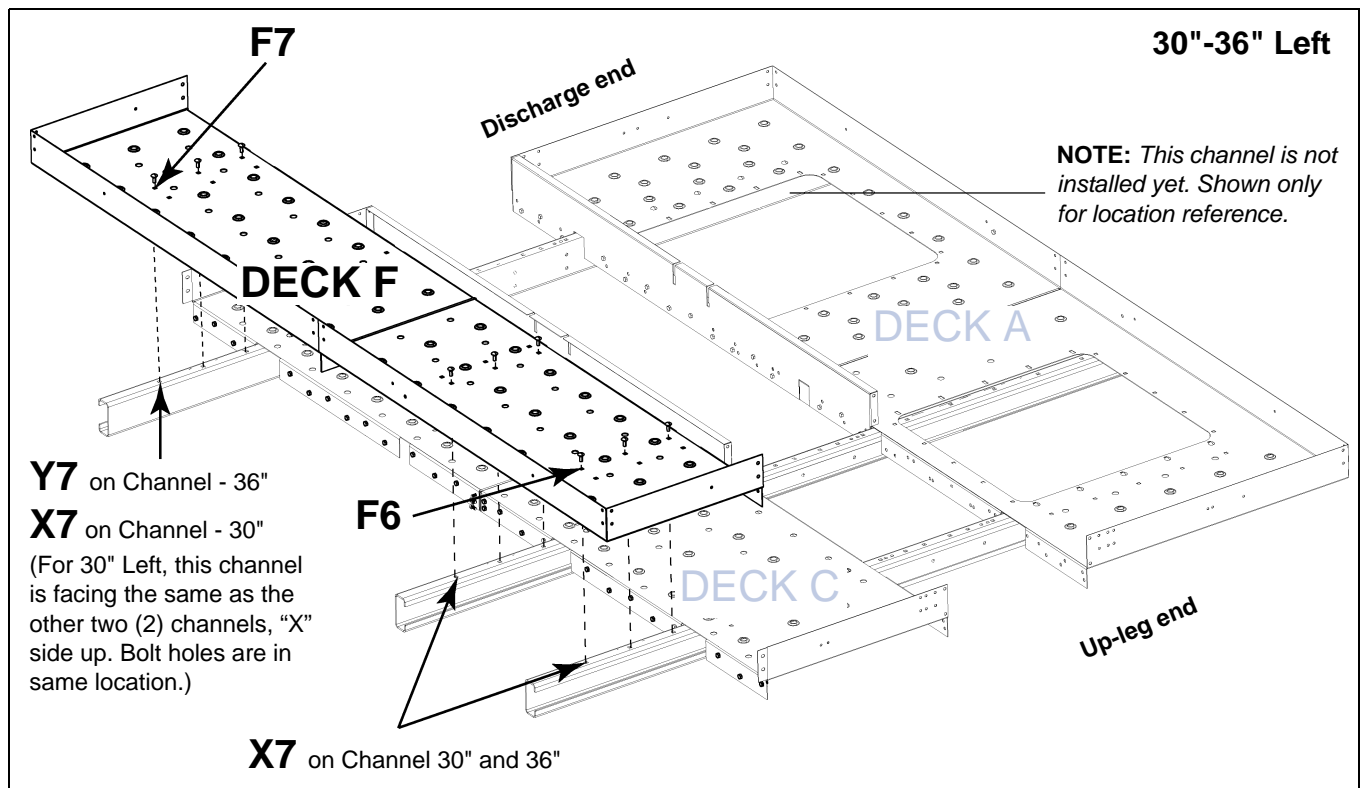

Figure 9L Deck F to Cross Deck Support Channel

9. 30"-36" Head Platform Left Hand Drive

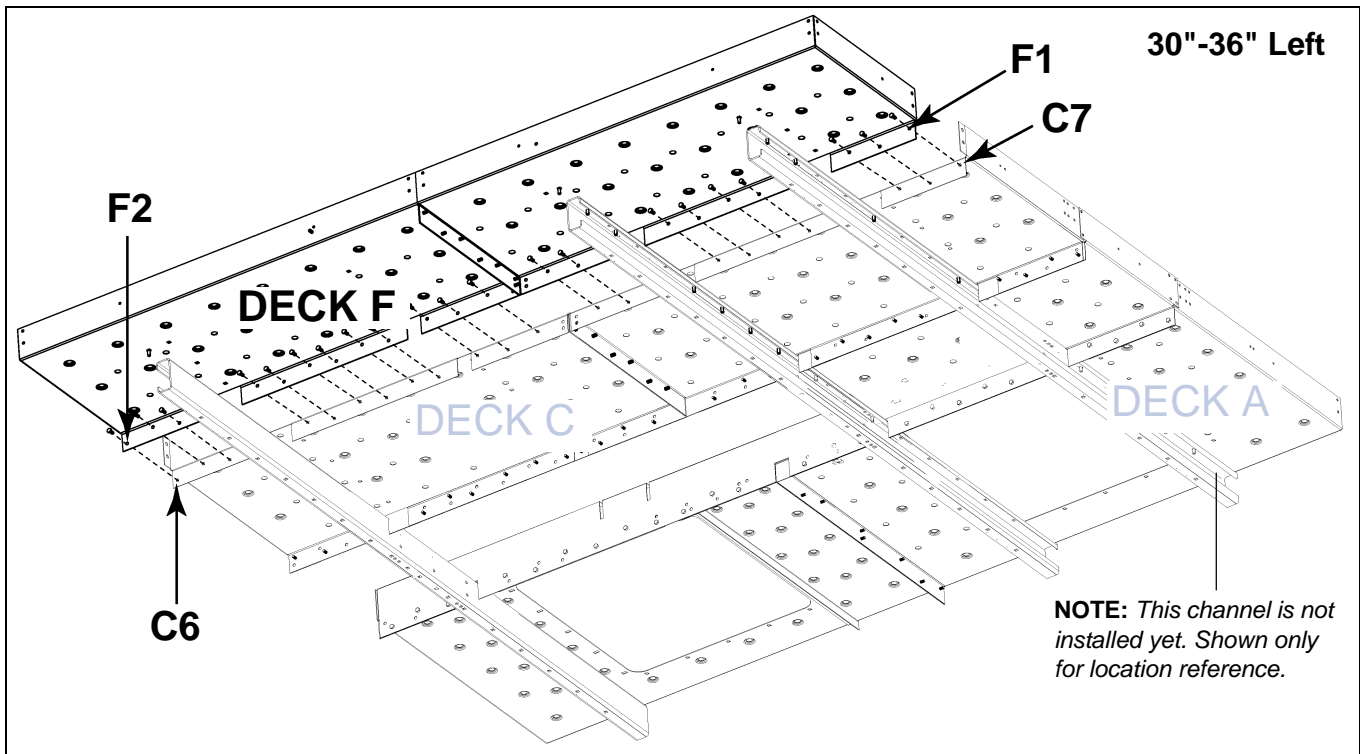

Figure 9M Deck F to Deck C

7. Install the head platform hatch deck support (HP1648HDS) (A) under Deck C and Deck F using 3/8" x 3/4" bolt (S-7105) and nut. (See Figure 9N.) **NOTE:** You may need to remove a bolt from the toe board if one was installed in this location.

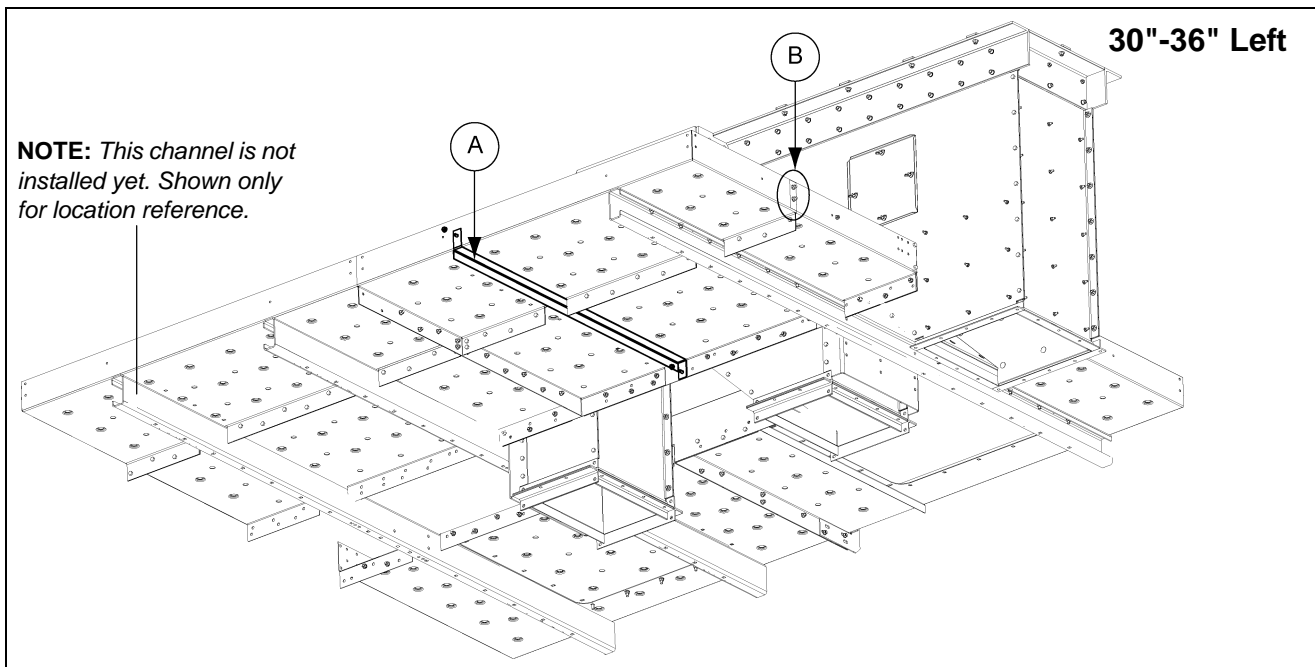

Figure 9N

Ref #	Part #	Description
A	HP1648HDS	HP Hatch Deck Support
B		Deck F Flange on Outside of Deck C Flange.

Attach Third Cross Deck Support Channel to Decking

NOTE: Connect all bolts only finger tight until deck is completely assembled and then tighten to proper torque.

1. Locate the third (3rd) cross deck support channel (HP36CDSCX) and orient it so the X side faces up and hole X1 is on the non-drive side of the lower head assembly.
2. Align holes. Use a punch as needed to align holes accordingly:
 - a. At the **drive side** - Channel hole **X7** on the cross deck support channel to Deck F hole **F6**.
(See Figure 9L on Page 77.)
 - b. At the **hatch side** - Channel hole **X2** on the cross deck support channel to Deck A hole **A10** and deck plate cover. (See Figure 9H on Page 74.)
 - c. Connect Deck F to support channels using 3/8" x 1" carriage bolts (S-3585) with flange nuts (S-10028). Connect all holes between channel and deck.

Attach Deck E to Deck A, Deck C and Cross Deck Support Channel

NOTE: Connect all bolts only finger tight until deck is completely assembled and then tighten to proper torque.

1. Position Deck E between Deck A and Deck C. Note that Deck E will be connected to two (2) channels. (See Figure 9P on Page 80.)
2. Align holes. Use a punch as needed to align deck holes **E5** with channel hole **X3**. This will align Deck E with holes on each channel. (See Figure 9O on Page 80.)
3. Connect Deck E to cross deck support channels using 3/8" x 1" carriage bolts (S-3585) with flange nuts (S-10028). Connect all holes between channels and deck.
4. Connect the Deck E kick plate flanges to toe boards and flanges of Deck A and Deck C using 3/8" x 3/4" bolts (S-7105) and 3/8" nuts (S-10028). (See Figure 9P on Page 80.)
5. Align and connect Deck E to Deck A and Deck C using 3/8" x 1" bolts (S-7469) with flange nuts (S-10028). (See Figure 9P on Page 80.)
 - a. C Deck hole **C12** to E deck hole **E1**.
 - b. C Deck hole **C9** to E deck hole **E2**.
 - c. A Deck hole **A13** to E deck hole **E3**.
 - d. A Deck hole **A11** to E deck hole **E4**.

9. 30"-36" Head Platform Left Hand Drive

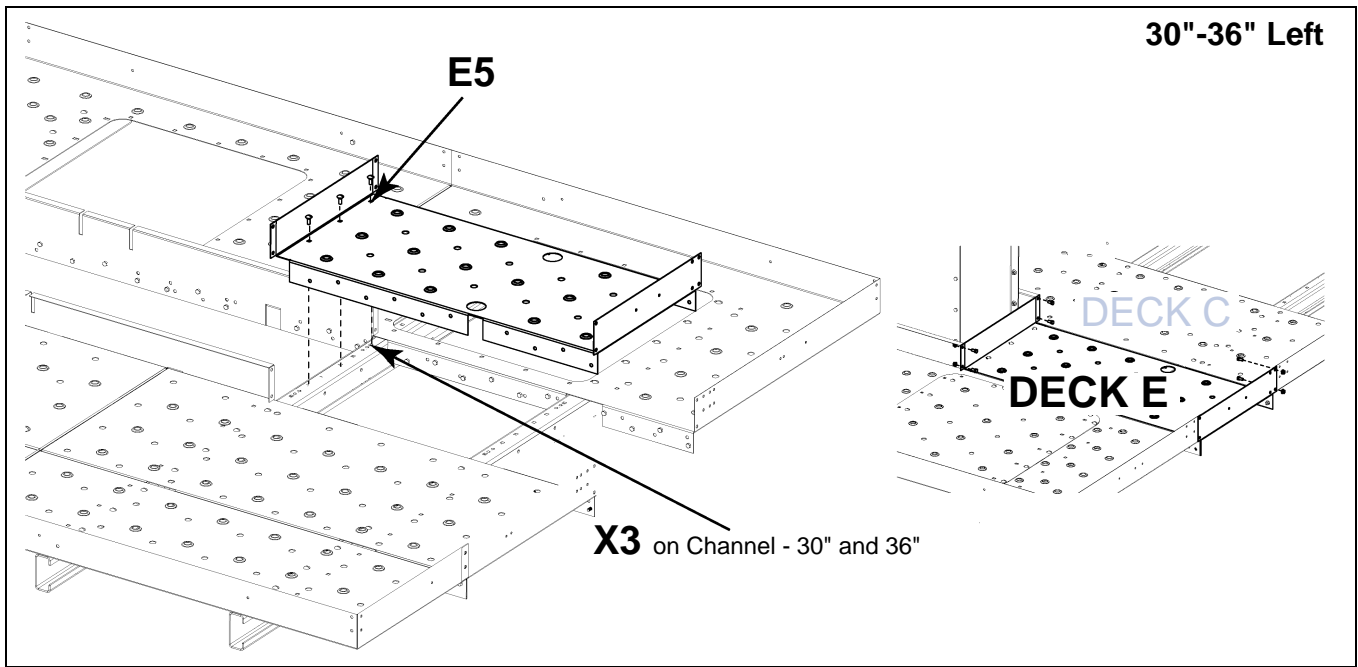

Figure 90



After decking is completely assembled, make sure to go back and tighten all bolts and nuts to the proper torque rating.

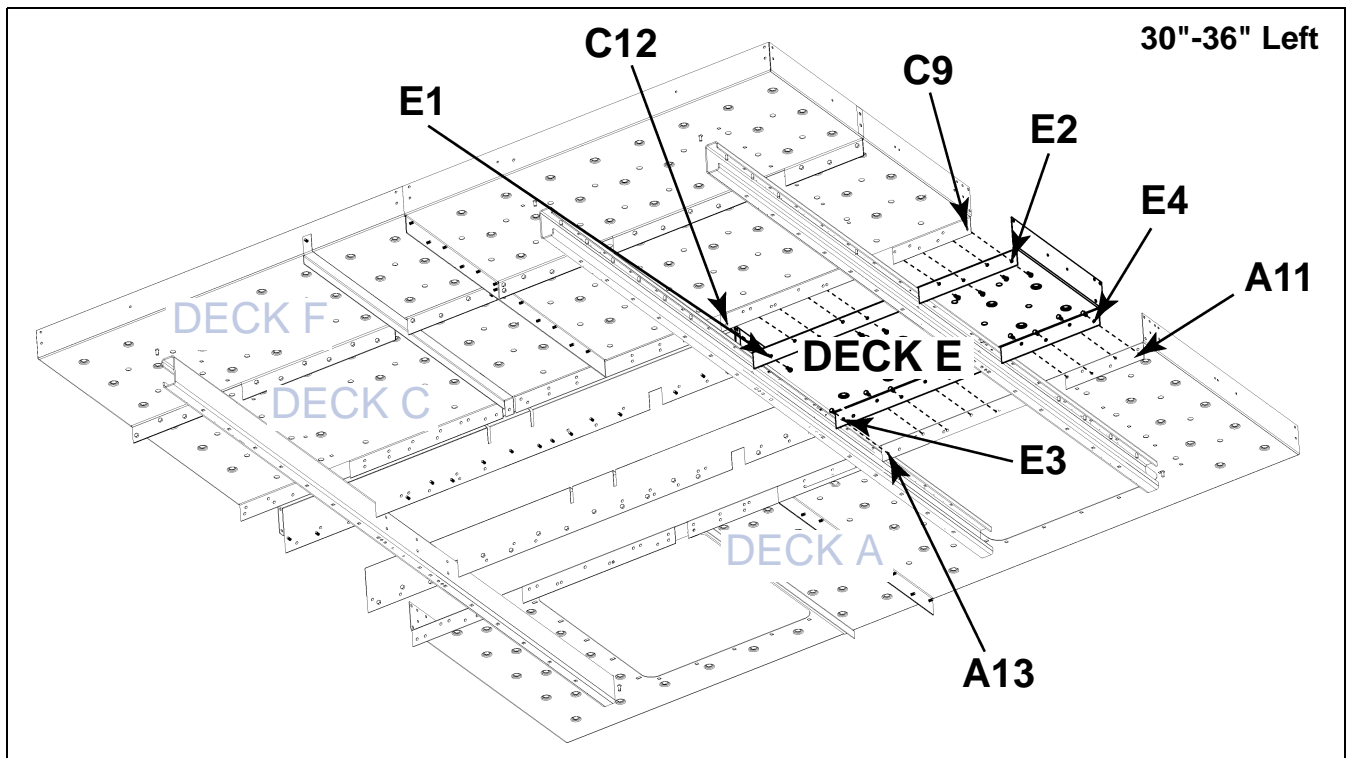

Figure 9P

Chapter 10: 30"-36" Head Platform Post, Rails and Bracing

The following assemblies occur the same on all 30"-36" platform installations, regardless of left or right drive orientation.

Attach Head Bearing Support Angle to Lower Head for 30"

1. Connect two (2) HP head bearing support brackets (HP30HBE) (B) as shown to the lower head using 3/8" x 1" bolts (S-7469) (C) and nuts (S-3611) (D).
2. Attach two (2) head bearing angle supports (HP30HBS) (A) to the head bearing support brackets (HP30HBE) (B) and cross deck support channels with 3/8" x 1" bolts (S-7469) (C) and nuts (S-3611) (D). (See Figure 10A.)

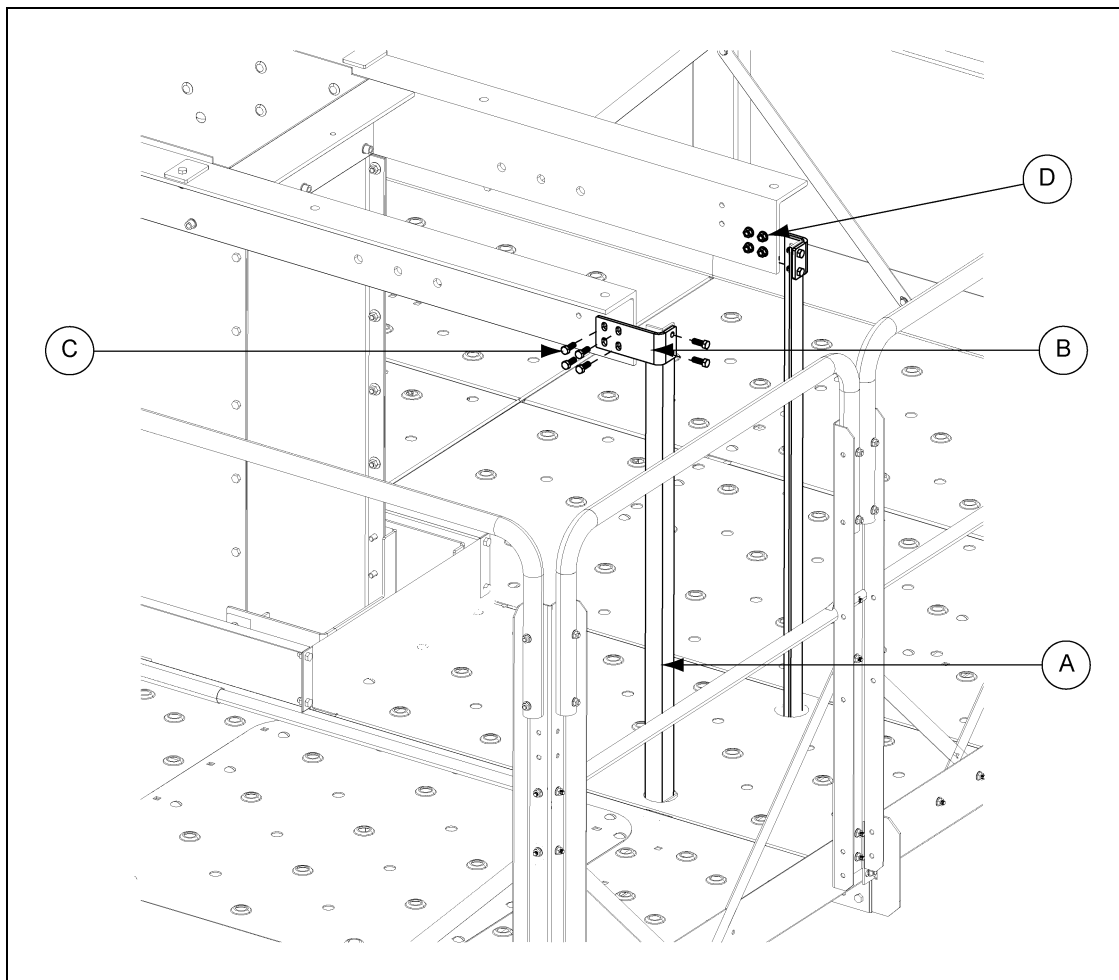

Figure 10A 30" Bearing Support Clips and Angles

Ref #	Part #	Description
A	HP30HBS	30" HP Head Bearing Support Angle
B	HP30HBE	30" Head Bearing Angle Support Bracket
C	S-7469	3/8" x 1" Bolt
D	S-3611	3/8" x 1" Flange Nut

10. 30"-36" Head Platform Post, Rails and Bracing

Attach Head Bearing Support Angle to Lower Head for 36"

1. Place two (2) head bearing angle supports (HP36HBS) (A) as shown in [Figure 10B](#).
2. Connect to lower head and cross deck support channel with 3/8" x 1" bolts (S-7469) and nuts.

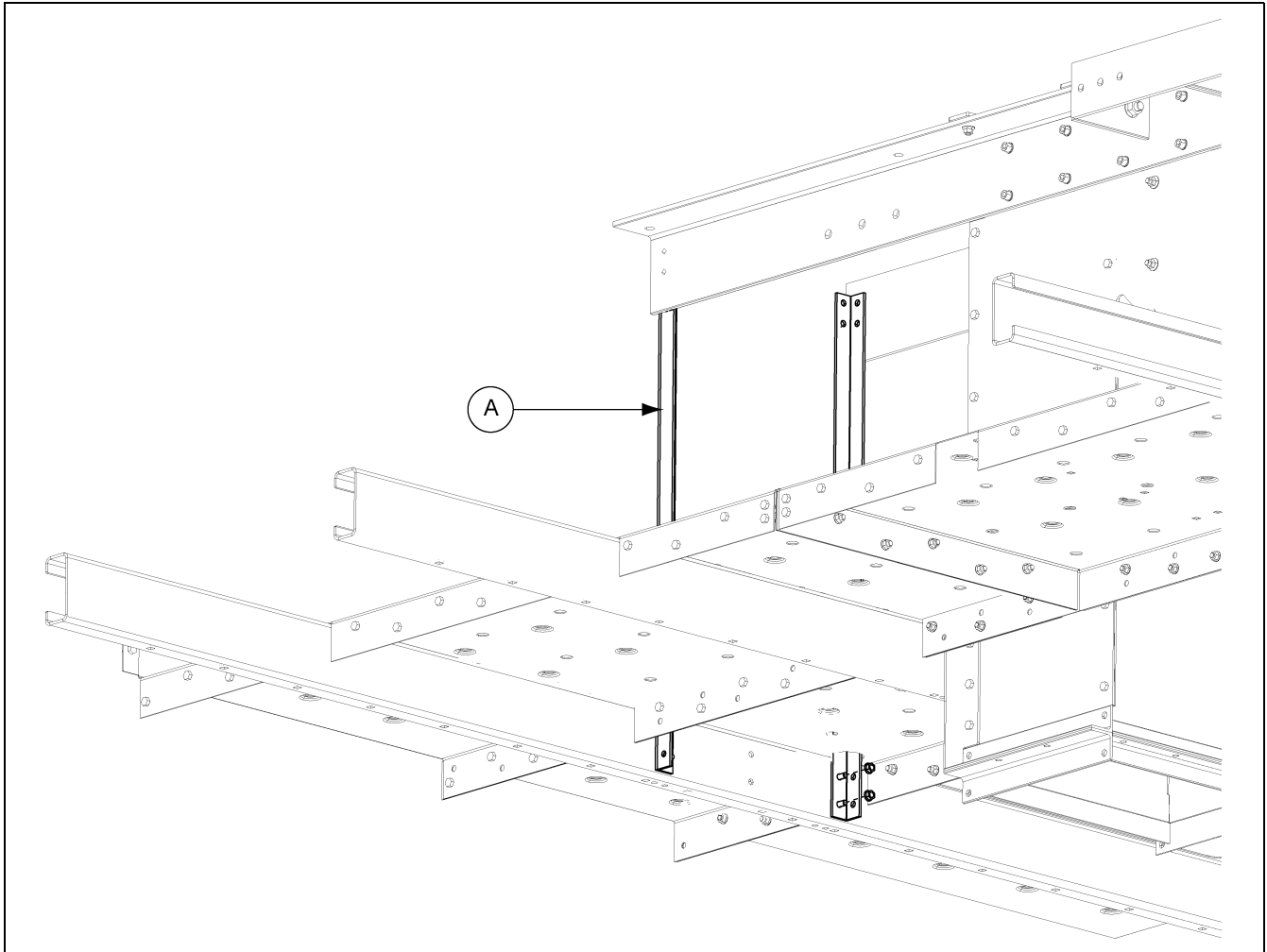

Figure 10B 36" Bearing Support Angle

Ref #	Part #	Description
A	HP36HBS	Head Bearing Angle Support

Attach Handrail Supports to Deck E

1. Attach two (2) HP handrail supports (HP1648HSH) to Deck E using 3/8" x 3/4" bolts and nuts. (See Figure 10C.) **NOTE:** The supports that attach to Deck A and Deck F attach at the same time as the platform post.

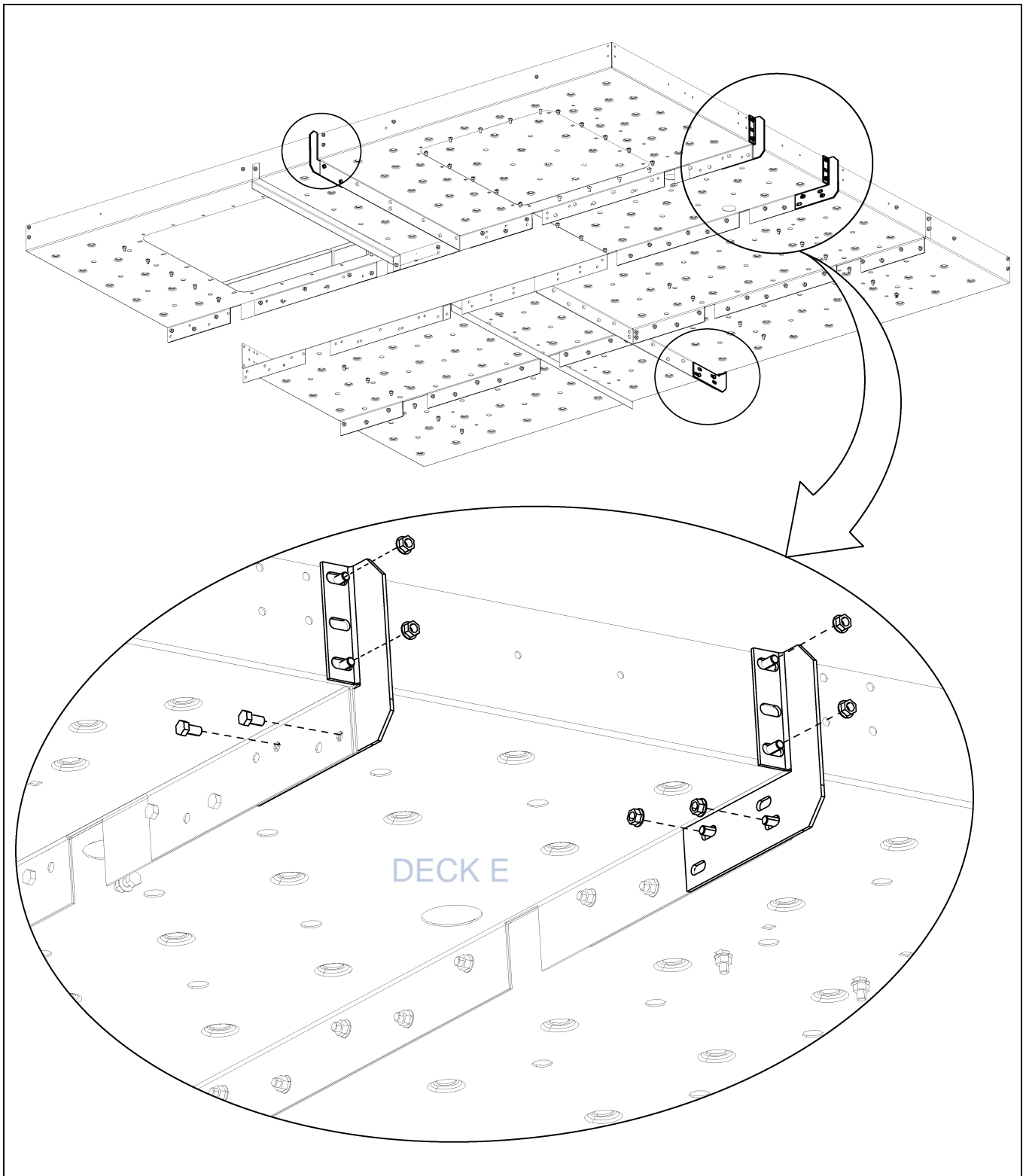

Figure 10C

10. 30"-36" Head Platform Post, Rails and Bracing

Install Posts

1. Attach two (2) "W" posts (HP1648HWP) (B) to the corner of Deck F using 5/16" x 3/4" bolts (S-6606) (D) and nuts (S-3611) (C).
2. Attach platform post (HP1648HCP) (A) and HP handrail support (HP1648HSH) (E) to the middle of Deck F. Use 5/16" x 3/4" bolts (S-6606) (D) to attach post to deck. Use 5/16" x 3/4" bolts (S-6606) (D) to attach support bracket, post and deck together. (See Figure 10D.)
3. Attach platform posts (HP1648HCP) (A) to Deck A and Deck C as shown in Figure 10D. Use four (4) 5/16" x 3/4" bolts (S-6606) (D) and nuts (S-3611) (C) for each post.

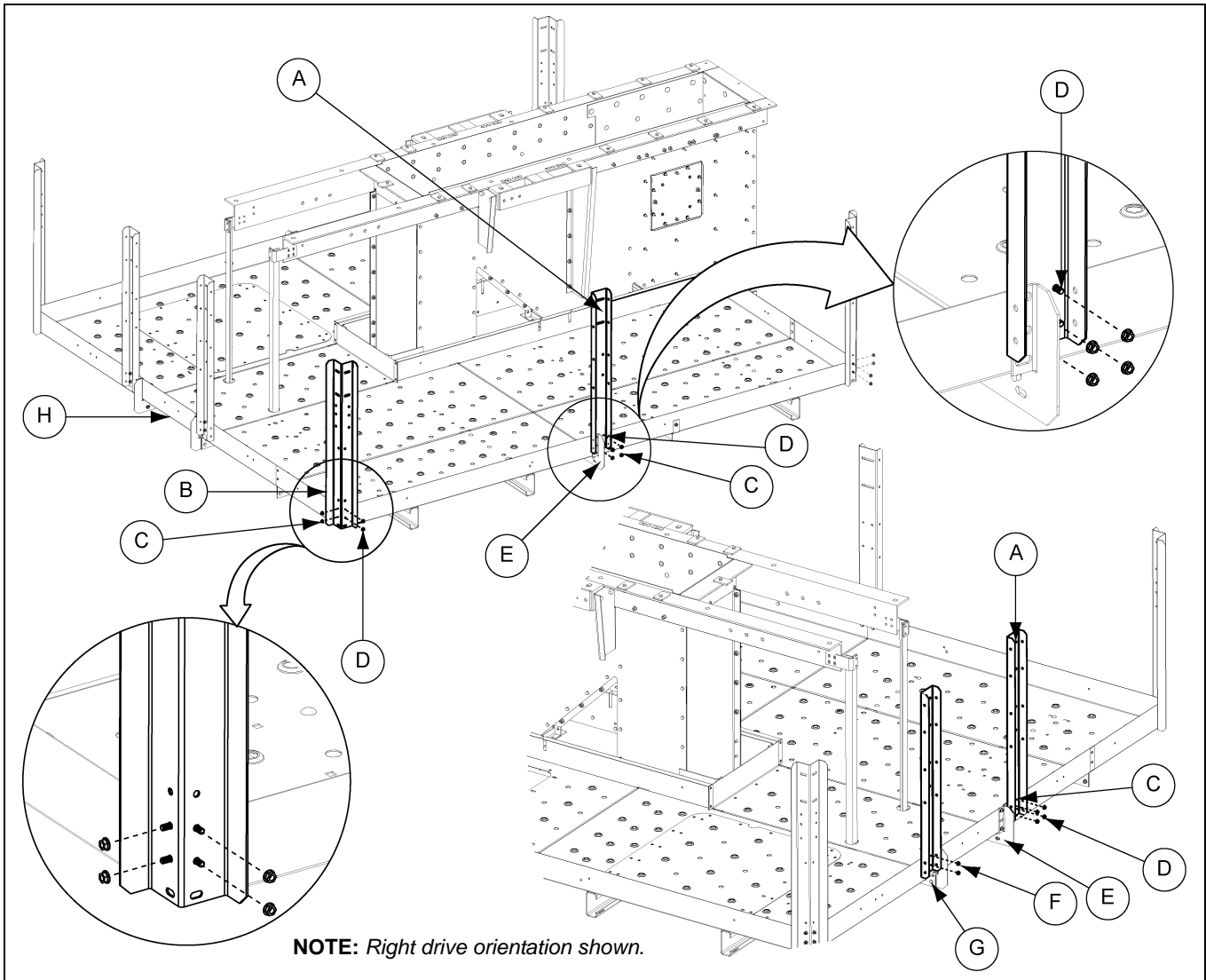

Figure 10D

Ref #	Part #	Description
A	HP1648HCP	Platform Post
B	HP1648HWP	Head/Distribution with Post
C	S-3611	5/16" Hex Flange Nut
D	S-6606	5/16" x 3/4" Bolt

Ref #	Part #	Description
E	HP1648HSH	HP Handrail Support
F	S-10028	3/8" Nut
G	S-7105	3/8" x 3/4" Bolt
H		E to Outside

Install Head Side Posts

For 30" Side Posts

1. Install side post (HP1648HP) (A) to decking. *(See Figure 10E.)*

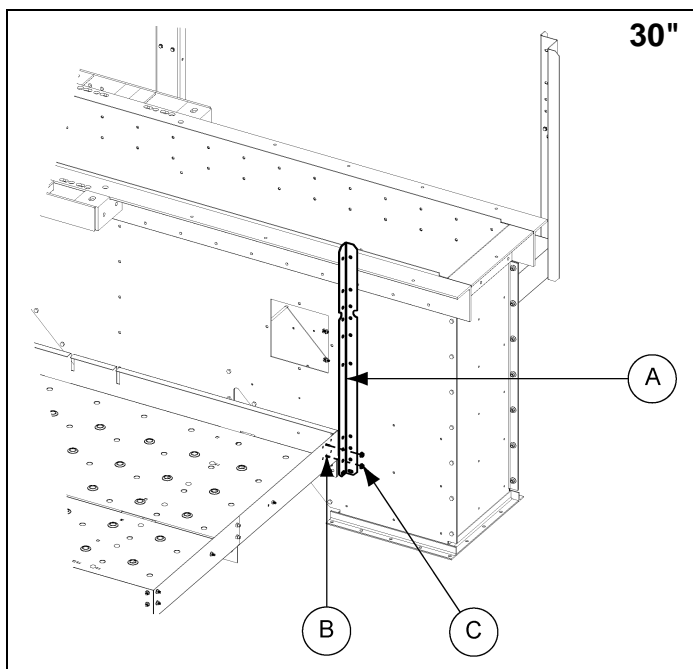

Figure 10E

2. Install handrail support bracket (HP30XHSPPT) (D) from toe board to side post (HP1648HP) (A) using 5/16" x 3/4" bolts (S-6606) (B) and nuts (S-3611) (C). *(See Figure 10F.)*

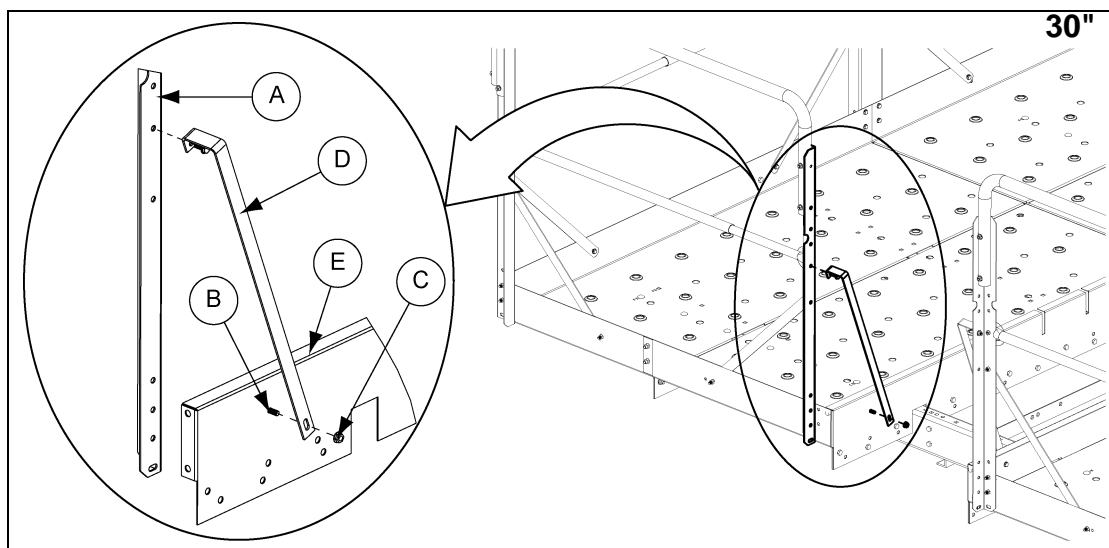

Figure 10F

Ref #	Part #	Description
A	HP1648HP	Head/Distributor Side Post
B	S-6606	5/16" x 3/4" Bolt
C	S-3611	5/16" Hex Flange Nut

Ref #	Part #	Description
D	HP30XHSPPT	30" HP Handrail Support Bracket
E	HP36STBX	36" HP Type "X" Side Toeboard

10. 30"-36" Head Platform Post, Rails and Bracing

Install Head Side Posts (Continued)

For 36" Side Posts

1. Attach two (2) HP handrail supports (HP1636HS) (F) to lower head using 3/8" x 1-1/4" bolt (S-2071) (G) and nut (S-968) (H). (See Figure 10G.)

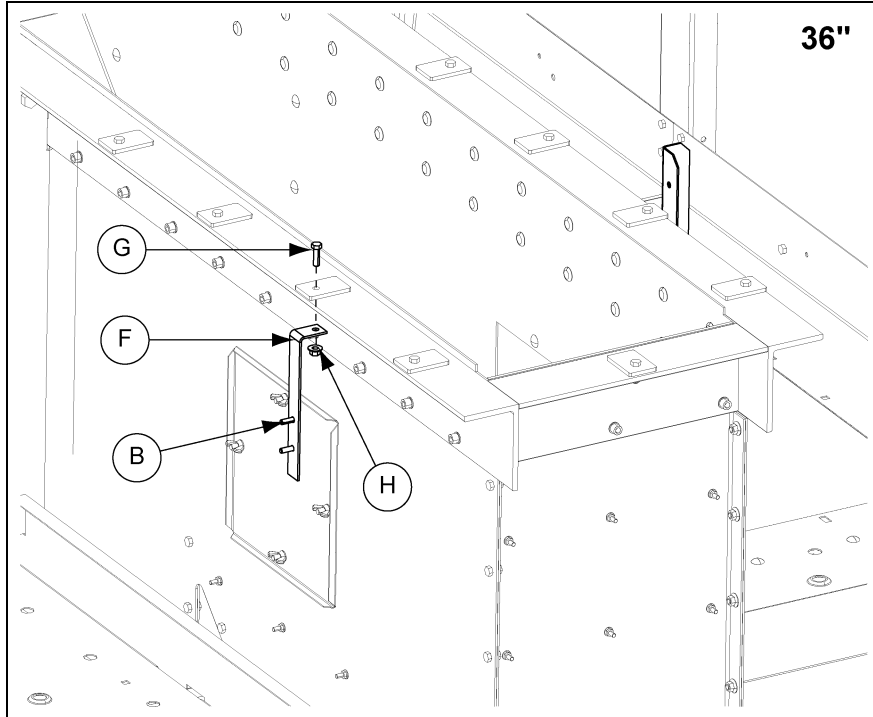

Figure 10G

2. Attach head side post (HP1648HP) (A) to lower head using 5/16" x 3/4" bolts and nuts. (See Figure 10H.)

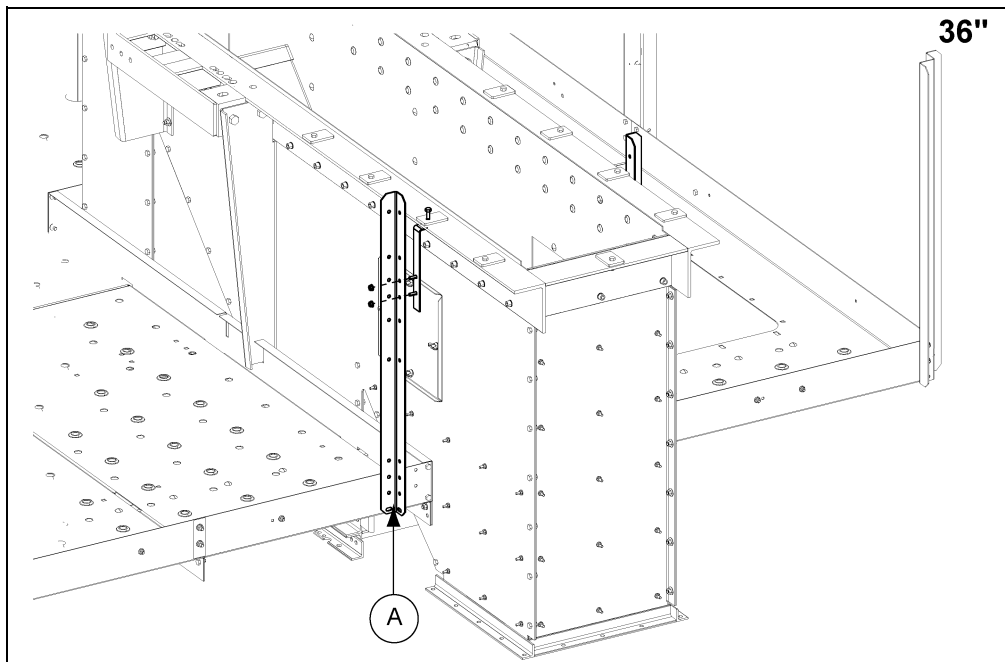

Figure 10H

Install Head Side Posts (Continued)

3. Attach side post to decking using 5/16" x 3/4" bolts (S-6606) (B) and nuts (H). (See Figure 10I.)

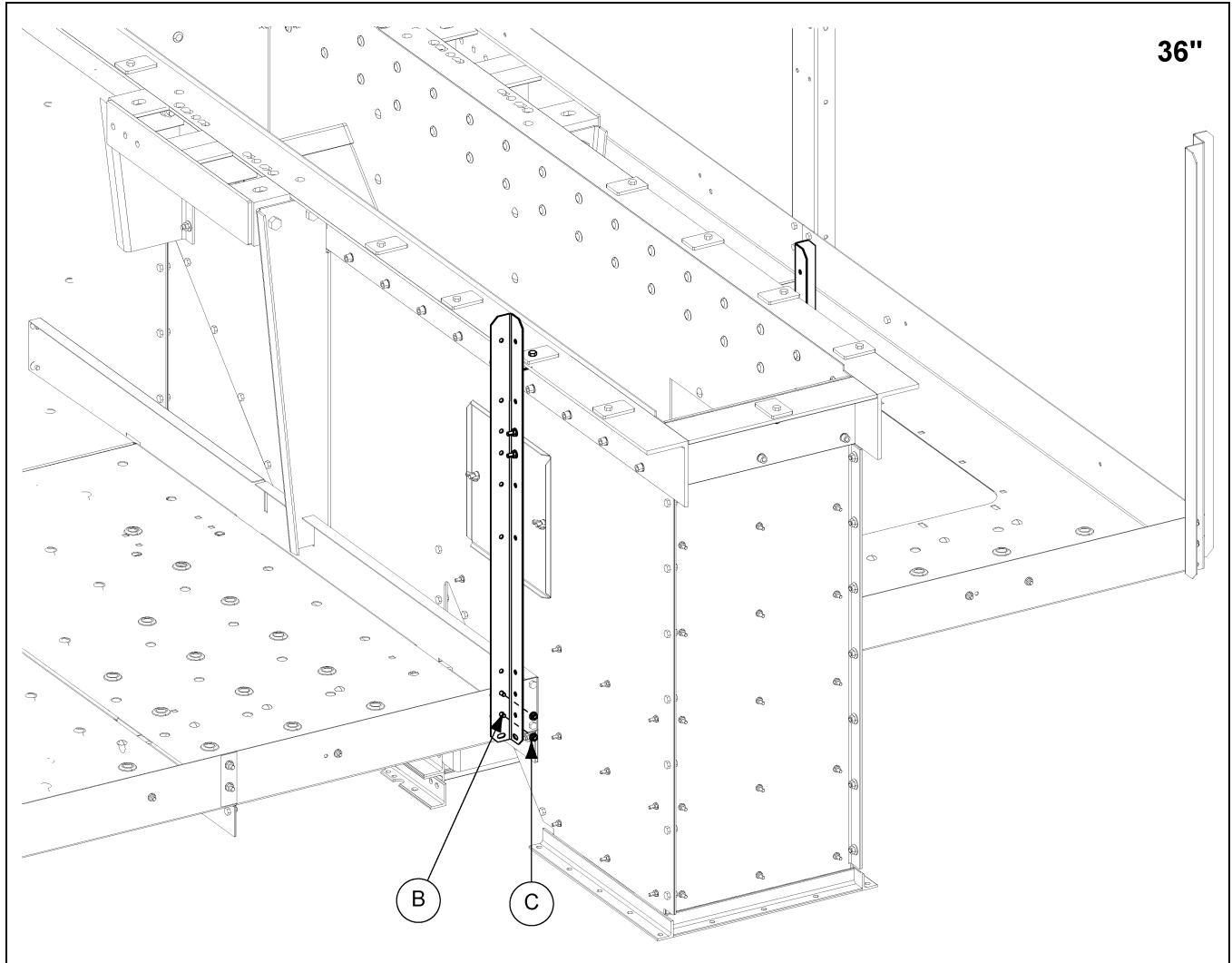

Figure 10I

Ref #	Part #	Description
A	HP1648HP	Head/Distributor Side Post
B	S-6606	5/16" x 3/4" Bolt
C	S-3611	5/16" Hex Flange Nut
F	HP1636HS	HP Handrail Support
G	S-2071	3/8" x 1-1/4" Bolt
H	S-968	3/8" Hex Nut

10. 30"-36" Head Platform Post, Rails and Bracing

Attach Intermediate Handrails to Posts

1. Cut 20" off the tube end of one small intermediate handrail (LDR-4088) (B) and one large intermediate handrail (LDR-4087) (A). (See Figure 10J.) Slide the small rail into the large rail and install between the posts opposite the discharge end and adjust to fit. Fasten using 5/16" x 3/4" bolts (S-6606) and nuts.
2. Cut 12" off the end of two (2) small intermediate handrail (LDR-4088) (B) and two (2) large intermediate handrail (LDR-4087) (A). (See Figure 10J.) Slide the small rails into the large rails and install one set at the discharge end of Deck A. Install the second set opposite the discharge end of Deck A. Fasten using 5/16" x 3/4" bolts (S-6606) and nuts.

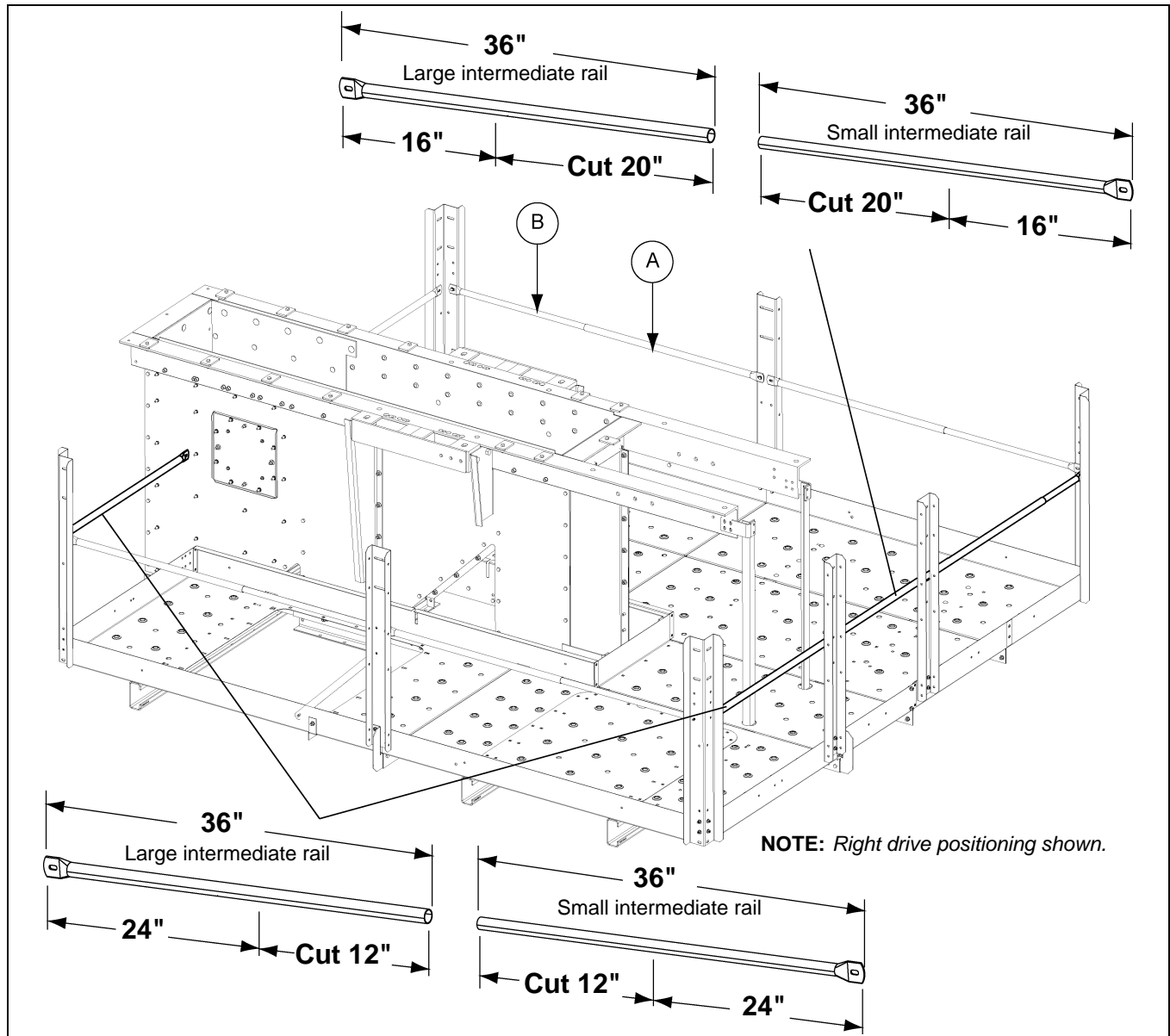

Figure 10J

Ref #	Part #	Description
A	LDR-4087	Large Intermediate Handrail
B	LDR-4088	Small Intermediate Handrail

Attach Intermediate Handrails to Posts (Continued)

3. Install the remaining Intermediate handrails around the platform using 5/16" x 3/4" bolts (S-6606) (C) and nuts (S-3611) (D). (See Figure 10K.)

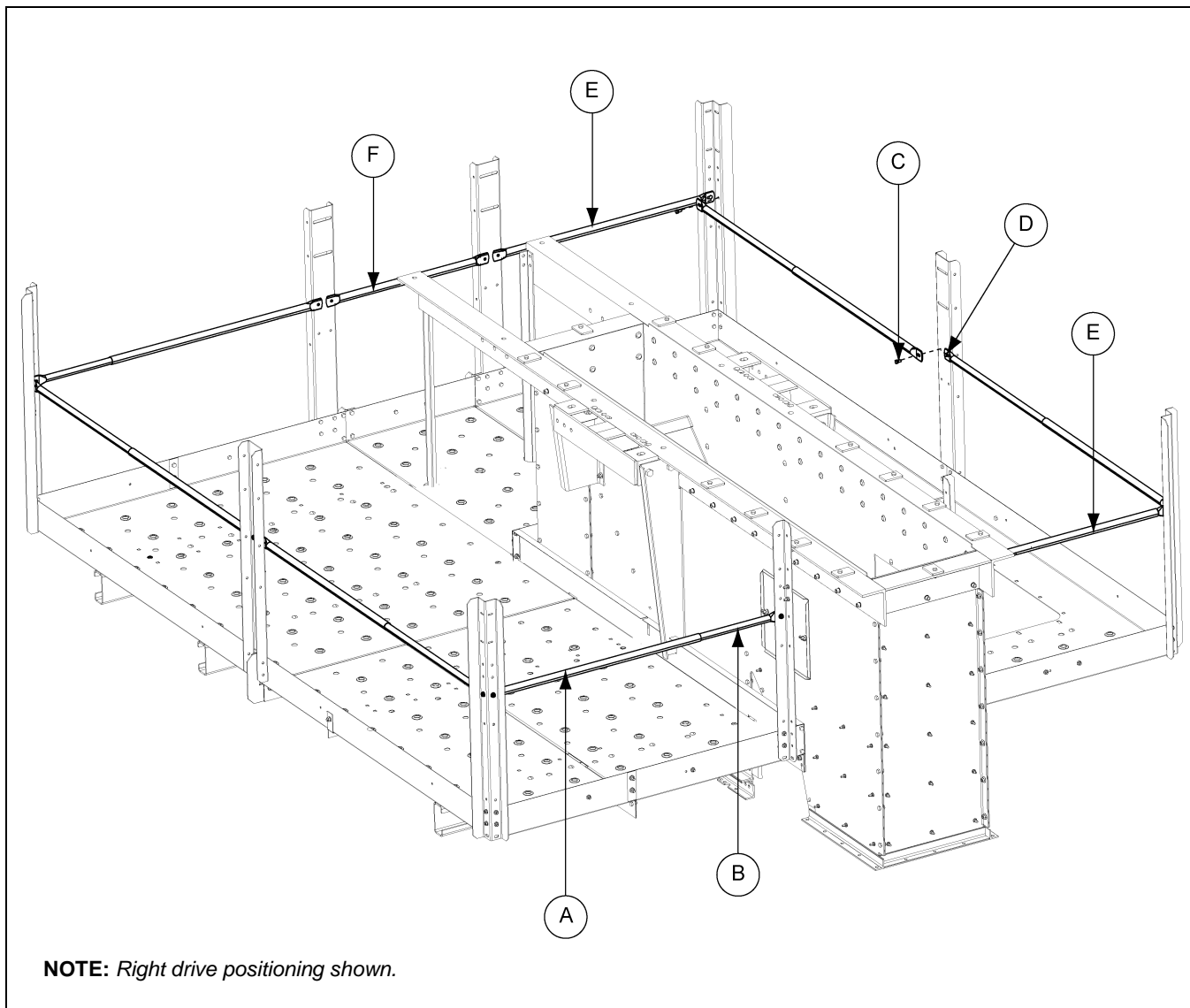

Figure 10K

Ref #	Part #	Description
A	LDR-4087	Large Intermediate Handrail
B	LDR-4088	Small Intermediate Handrail
C	S-6606	5/16" x 3/4" HHCS Bolt
D	S-3611	5/16" Hex Flange Nut
E		Cut 12"
F		Cut 20"

10. 30"-36" Head Platform Post, Rails and Bracing

Install Upper Handrails

1. Attach handrails to the handrail posts using 5/16" x 2" bolts (S-7877) and hex nuts. Use [Figure 10L below](#) and [Figure 10M on Page 91](#) for handrail location.

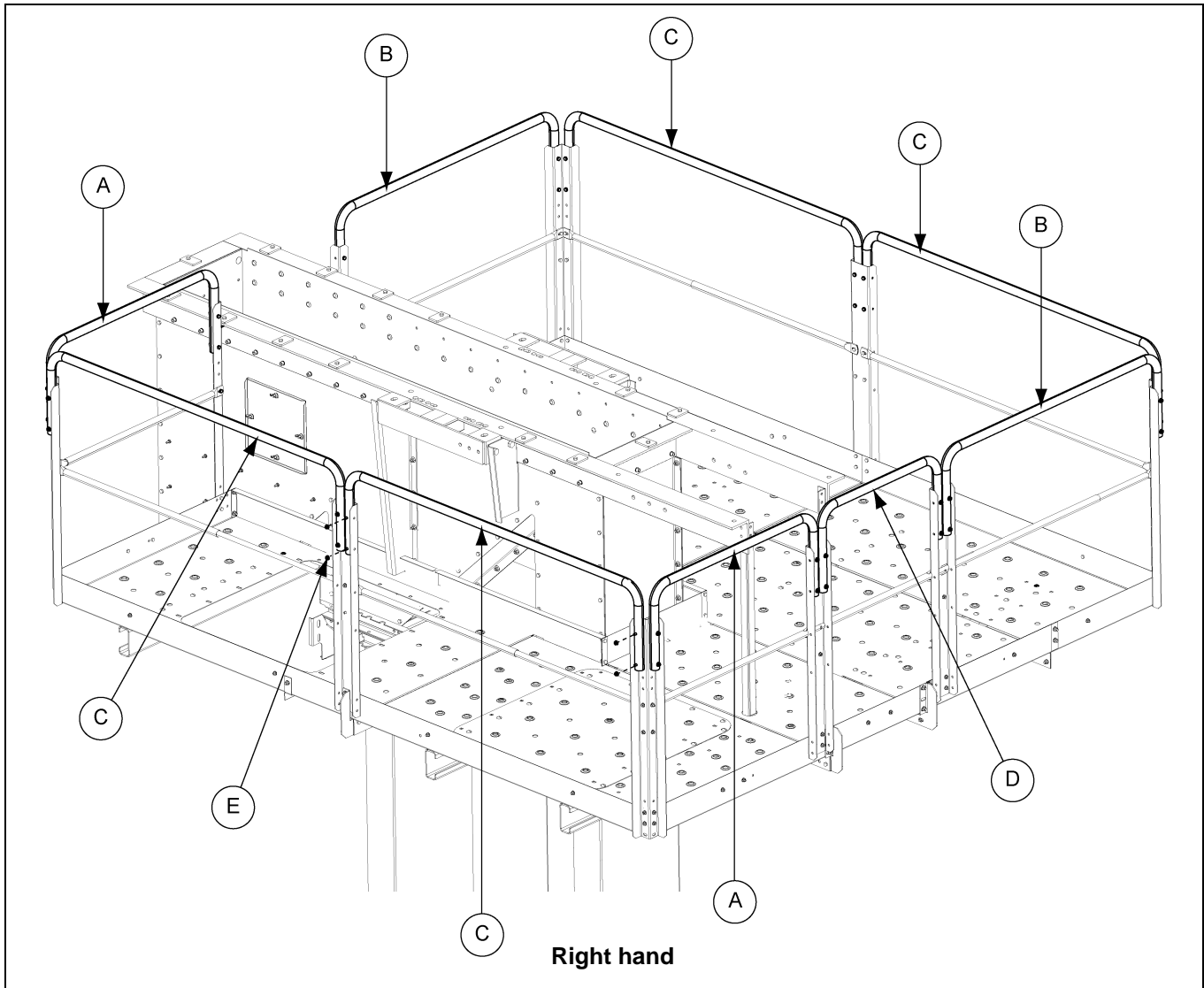

Figure 10L Right Hand Drive Rail Locations

Ref #	Part #	Description
A	HP1648HLH	36.895" Hatch Handrail
B	HP1648HRD	49" Drive Handrail
C	HP1648HDH	64.126" Drive/Hatch Handrail
D	HD1648HMD	26.7" Middle Drive Handrail
E	S-3611	5/16" Hex Flange Nut

Install Upper Handrails (Continued)

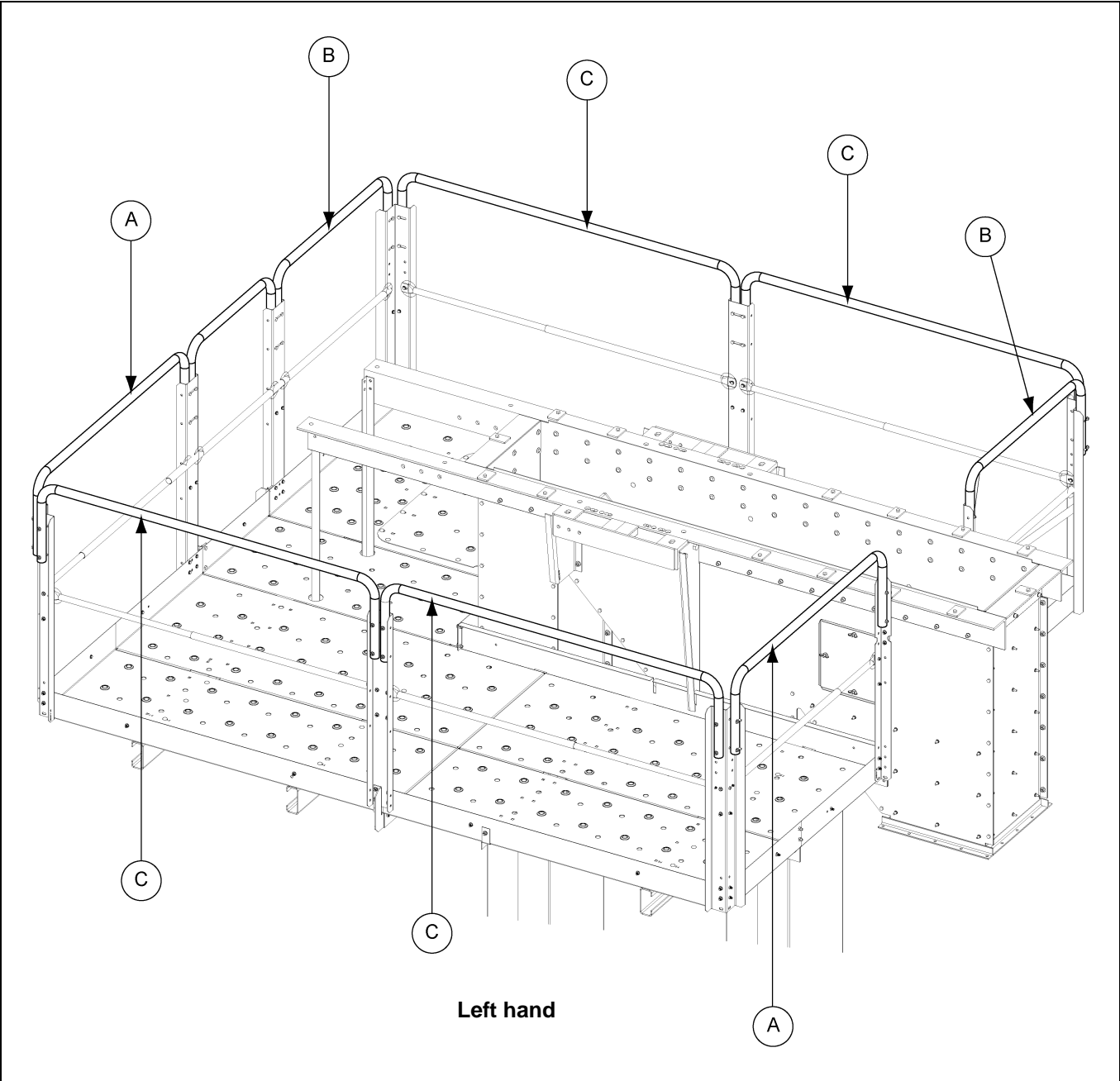

Figure 10M Left Hand Drive Rail Locations

Ref #	Part #	Description
A	HP1648HLH	36.895" Hatch Handrail
B	HP1648HRD	49" Drive Handrail
C	HP1648HDH	64.126" Drive/Hatch Handrail

10. 30"-36" Head Platform Post, Rails and Bracing

Install Safety Cage Bar Cross Supports

1. Attach safety cage bar - 24" (LDR-5171BE) (A) from handrail post to decking kick plates using 5/16" x 3/4" bolts (S-6606) (B) and nuts (S-3611) (C). (See Figure 10N.)

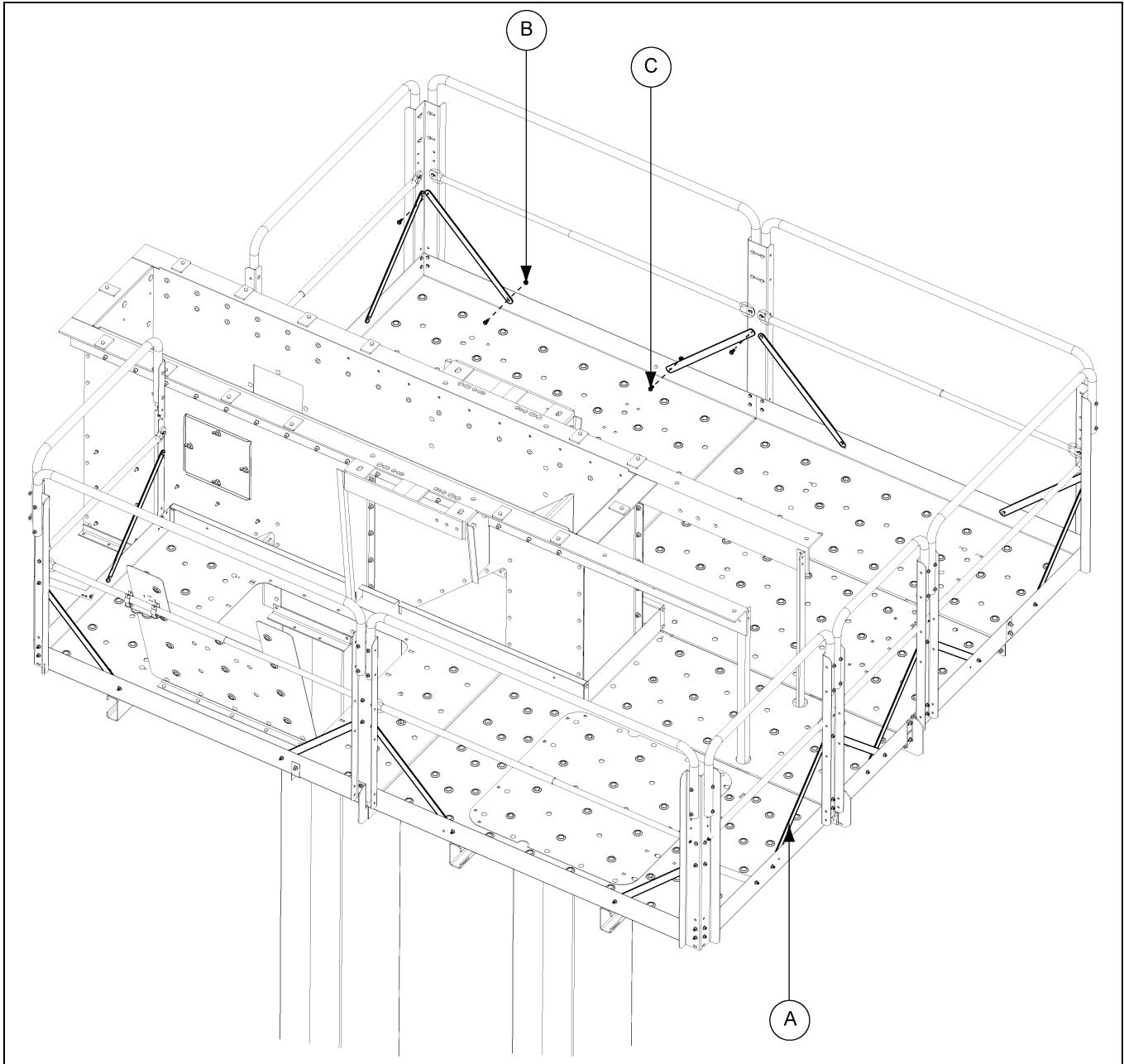

Figure 10N

Ref #	Part #	Description
A	LDR-5171BE	24" Safety Cage Bar
B	S-6606	5/16" x 3/4" Bolt
C	S-3611	5/16" Hex Flange Nut

Chapter 11: Install Hatch

1. Attach hatch hinge (HP1624HH) (B) to the hatch deck door (HP1624HDD) (A). Orient hinge so that it opens the desired direction. (See Figure 11A.) Fasten using 3/8" x 1" carriage bolts (S-3585) (C) hardware.

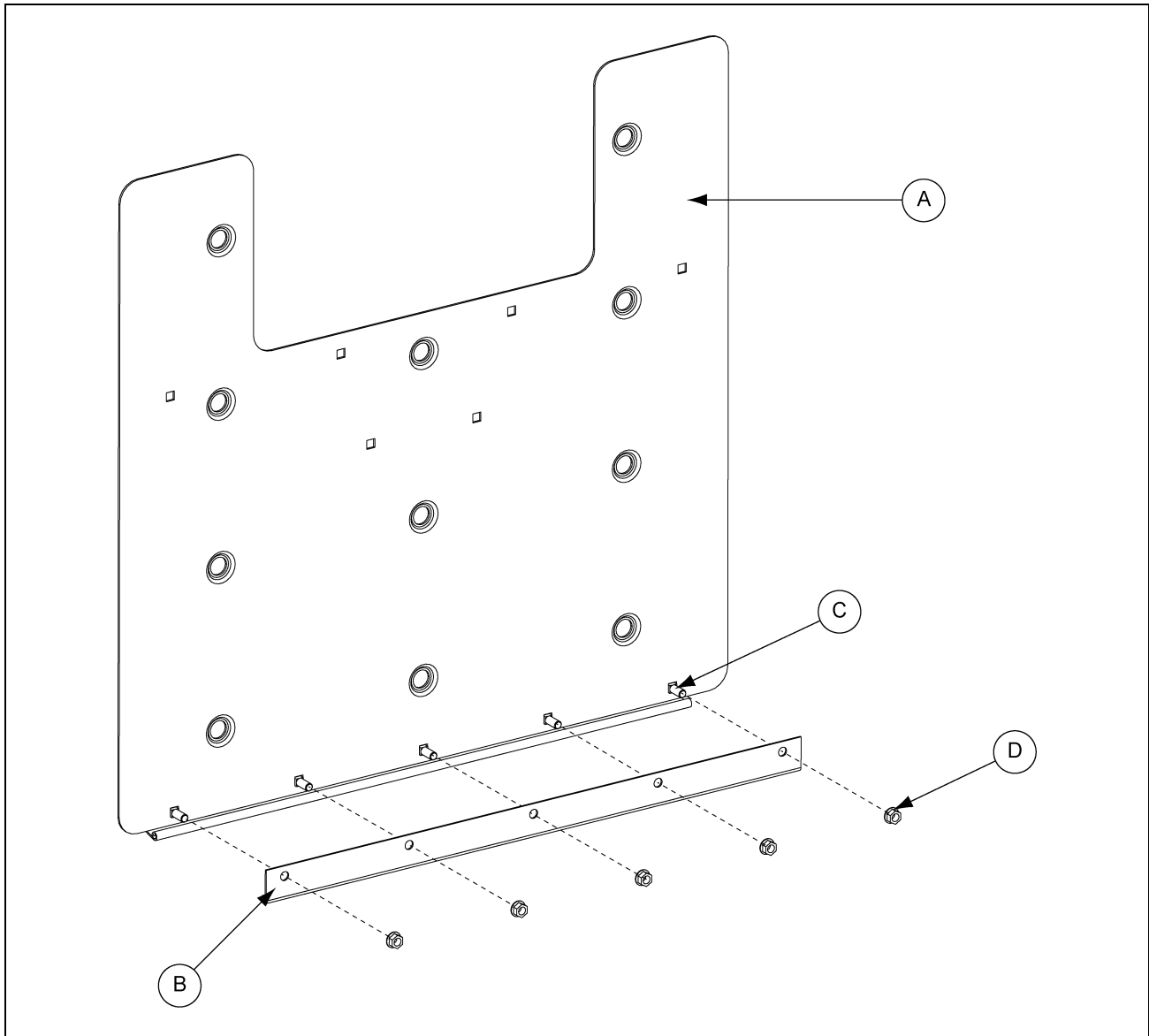

Figure 11A

Ref #	Part #	Description
A	HP1624HDD	Hatch Deck Door
B	HP1624HH	Hatch Hinge
C	S-3585	3/8" x 1" Carriage Bolts
D	S-10028	3/8" Hex Nut

11. Install Hatch

2. Install hatch support (HP1624HS) to the bottom of the hatch door using 3/8" x 1" carriage bolts (S-3585) (C) and nuts (S-10028) (D). (See Figure 11B.)
3. Fasten peak cap handle (PR-331) (B) to the bottom of the hatch door using 3/8" x 1" carriage bolts (S-3585) (C) and nuts (S-10028) (D).

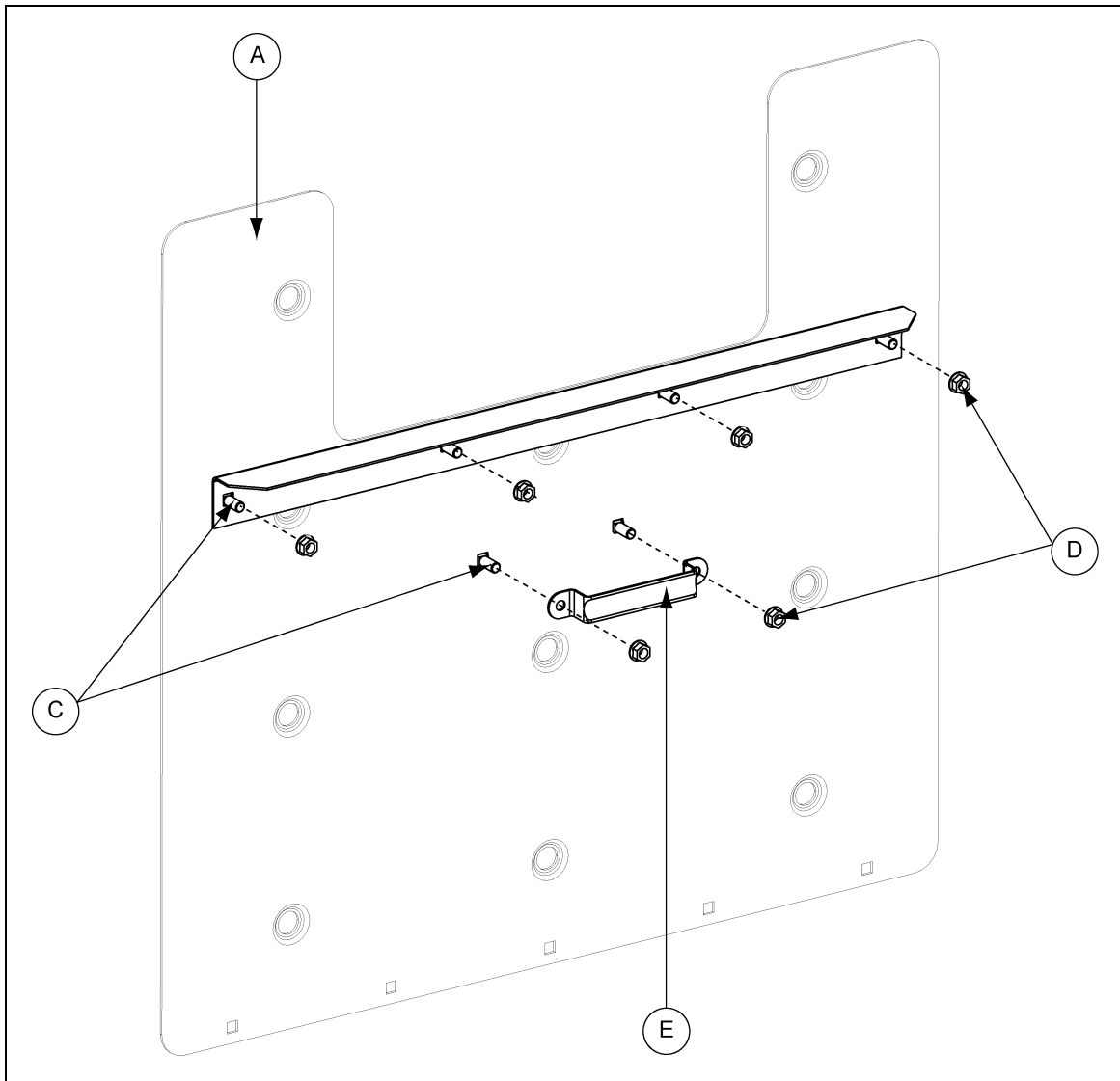

Figure 11B

Ref #	Part #	Description
A	HP1624HDD	Hatch Deck Door
C	S-3585	3/8" x 1" Carriage Bolt
D	S-10028	3/8" Hex Nuts
E	PR-331	Peak Cap Handle

4. Slide two (2) magnets (16-0092) onto each MS #6 x 3/4" FHS flat head screw (S-7166). Position the magnet so the screw head is countersunk into the magnet. (See Figure 11C.)
5. Insert screws with magnets through the hatch door and fasten with the #6 flange nut (S-10133).

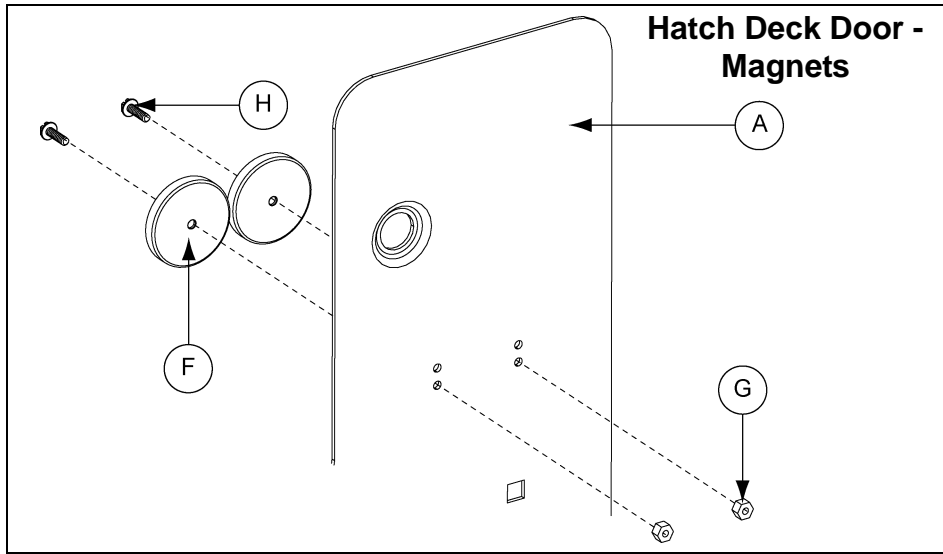

Figure 11C

Ref #	Part #	Description
A	HP1624HDD	Hatch Deck Door
F	HP1648MAG	Magnet
G	S-2010	Nylock Nut #10-24 ZN Grade 2
H		Screw, MS #10-24 x 5/8" HWHS ZN Grade 2

6. Align holes on the hatch hinge (HP1624HH) (B) with holes along the deck opening closest to the kick plates. Install the hatch door to the decking using 3/8" x 3/4" bolts (S-7105) (I) and nuts. (See Figure 11D.)

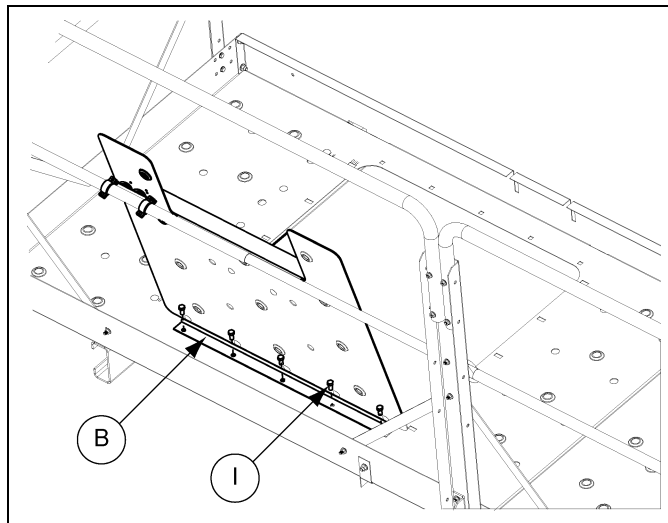

Figure 11D

Ref #	Part #	Description
B	HP1624HH	Hatch Hinge
I	S-7105	3/8" x 3/4" Bolt

11. Install Hatch

7. Assemble pipe clamps (S-10139) (J) to the magnet mount hatch bracket (HP1648LMM) (K). Insert 3/8" x 3/4" carriage bolts (L) through the magnet mount hatch bracket (HP1648LMM) (K), 1/2" flat washer (M) and pipe clamp (S-10139) (J). Fasten with 3/8" nut (N). *(See Figure 11E.)*
8. Attach pipe clamp around intermediate handrail and fasten loosely with bolts. Open hatch plate and slide clamp along handrail until it lines up with the magnets on the hatch plate. Tighten clamp to rail.

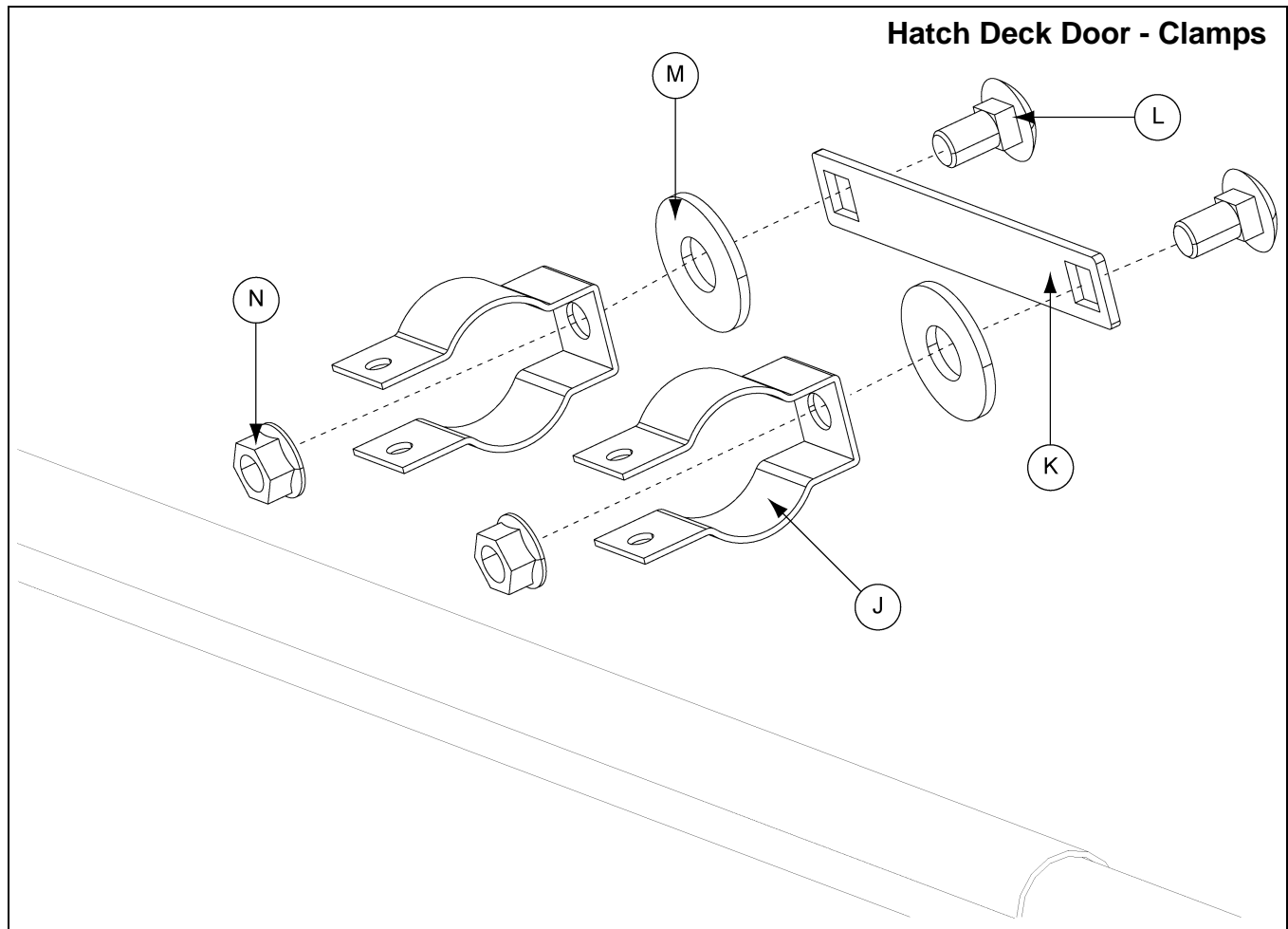

Figure 11E

Ref #	Part #	Description
J	S-10139	Pipe Clamp 1" O.D. 3/8" Holes with Screw
K	HP1648LMM	Magnet Mount Hatch Bracket
L		3/8" x 3/4" Carriage Bolt
M		1/2" Flat Washer
N		3/8" Nut

Chapter 12: 4 x 5 Distributor Platform (Optional)

The distributor platform is optional and only used on bucket elevators that have a distributor spout. The platform is used to access the distributor for maintenance and control adjustments. The platform should be located below the distributor head. **NOTE:** *That the clamp installation to the trunking is different for 16", 24" and the 30"-36" but the rest of the assembly is the same.*

Install Clamp Band

30"-36" Top Clamp Band to Trunking

NOTE: *30"-36" Top and bottom clamps assemble the same. One attaches to the support channel and one attaches to the brace channels.*

1. Slide rods of clamp rod weldment (DSP16005) (E) into outside set of holes of clamp bands for both the top and bottom assemblies. Fasten together using four (4) 1/2" hex flange nuts (S-8506) (F) per each clamp.
2. Assemble the top and bottom clamp band weldments, clamp channel (DSP16001) (C) and clamp clips (GSB30144) (B) at same time around the trunking. Place clamp rod weldment (DSP16005) (E) assembly around the trunking leg and line up holes on clamp channel (DSP16001) (C) and clamp clips (GSB30144) (B) with the **inside set of holes** on the clamp bands (DSP16002) (D). Fasten all together using six (6) 1/2" x 1" bolts (S-7935) (G) and nuts (S-8506) (F). *(See Figure 12A on Page 98.)*
3. Line up the holes located at the end of the distributor support channels (A) and brace channels (H) with the holes on the clamp clips (GSB30144) (B). Fasten together using four (4) 1/2" x 1" bolts (S-7935) (G) and nuts (S-8506) (F).

12. 4 x 5 Distributor Platform (Optional)

Install Clamp Band (Continued)

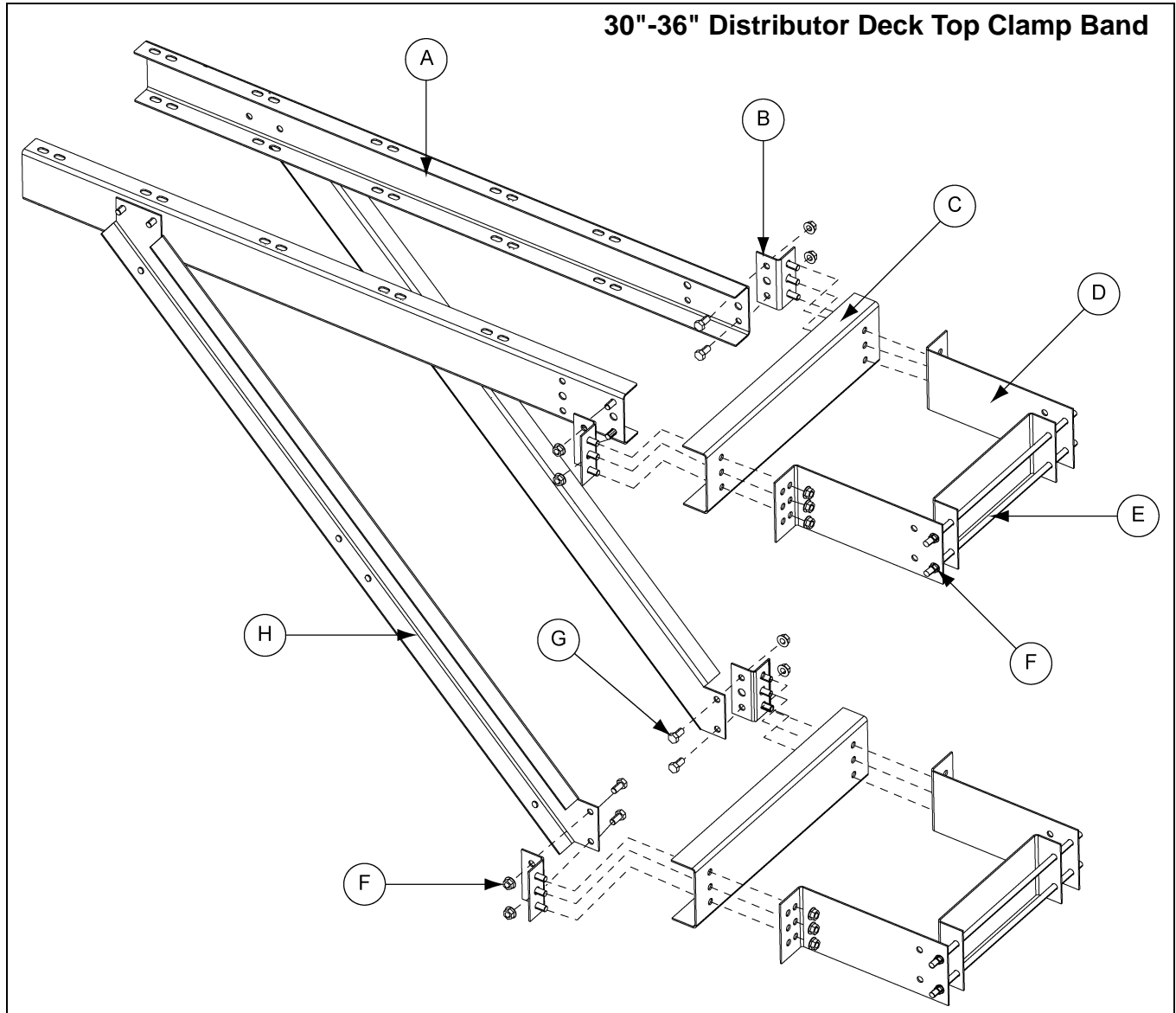

Figure 12A

Ref #	Part #	Description
A	GSB30210X	Distributor Support Channel (+5")
B	GSB30144	Clamp Clip
C	DSP16001	Clamp Channel
D	DSP16002	Distributor Clamp Band
E	DSP16005	Clamp Rod Weldment
F	S-8506	1/2" Hex Flange Nut
G	S-7935	1/2" x 1" Bolt
H	GSB30147	Brace Channel

Assemble Supports

Support Channel, Cross Support and Knee Brace Assembly

1. Attach brace channels (GSB30147) (E) to the sides of the support channels using four (4) 1/2" x 1" bolts (S-7935) (C) and nuts (S-8506) (D). Angle the knee braces (GSB30148) (F) across the bottom sides of the brace channels (GSB30147) (E) and attach using four (4) 1/2" x 1" bolts (S-7935) (C) and nuts (S-8506) (D).
2. Assemble the cross supports (DSP1648CS) (B) to the bottom side of the support channels (GSB30210X) (A) using the end and middle sets of holes on the support channels (GSB30210X) (A) using four (4) 1/2" x 1" bolts (S-7935) (C) and nuts (S-8506) (D). *(See Figure 12B.)*
3. Assemble the external platform support (DSP1648EPS) to the end of the three (3) cross supports using six (6) 1/2" x 1" bolts (S-7935) (C) and nuts (S-8506) (D). *(See Figure 12C on Page 100.)*

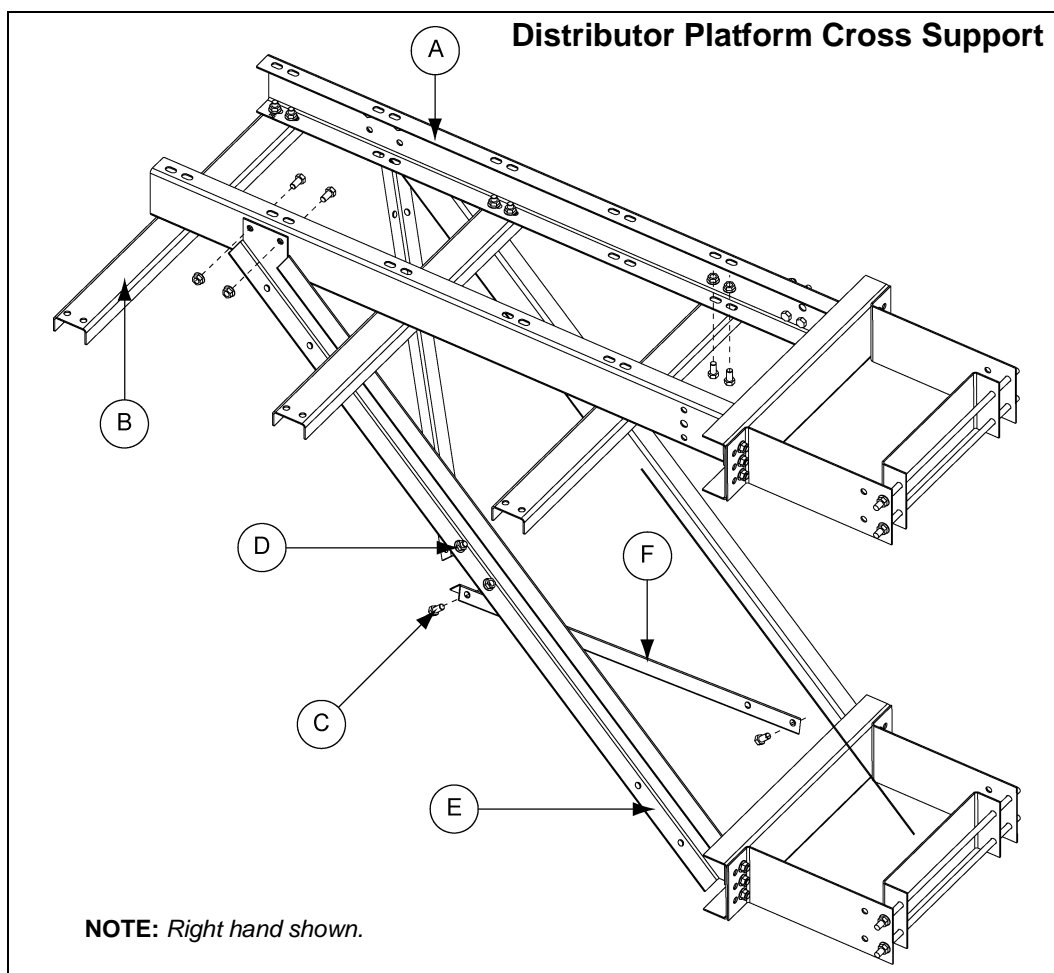

Figure 12B Distributor Platform Cross Support

Ref #	Part #	Description	Ref #	Part #	Description
A	GSB30210X	Distributor Support Channel (+5")	D	S-8506	1/2" Hex Flange Nut
B	DSP1648CS	Distributor Platform Cross Support	E	GSB30147	Brace Channel
C	S-7935	1/2" x 1" Bolt	F	GSB30148	Knee Brace

12. 4 x 5 Distributor Platform (Optional)

Assemble Supports (Continued)

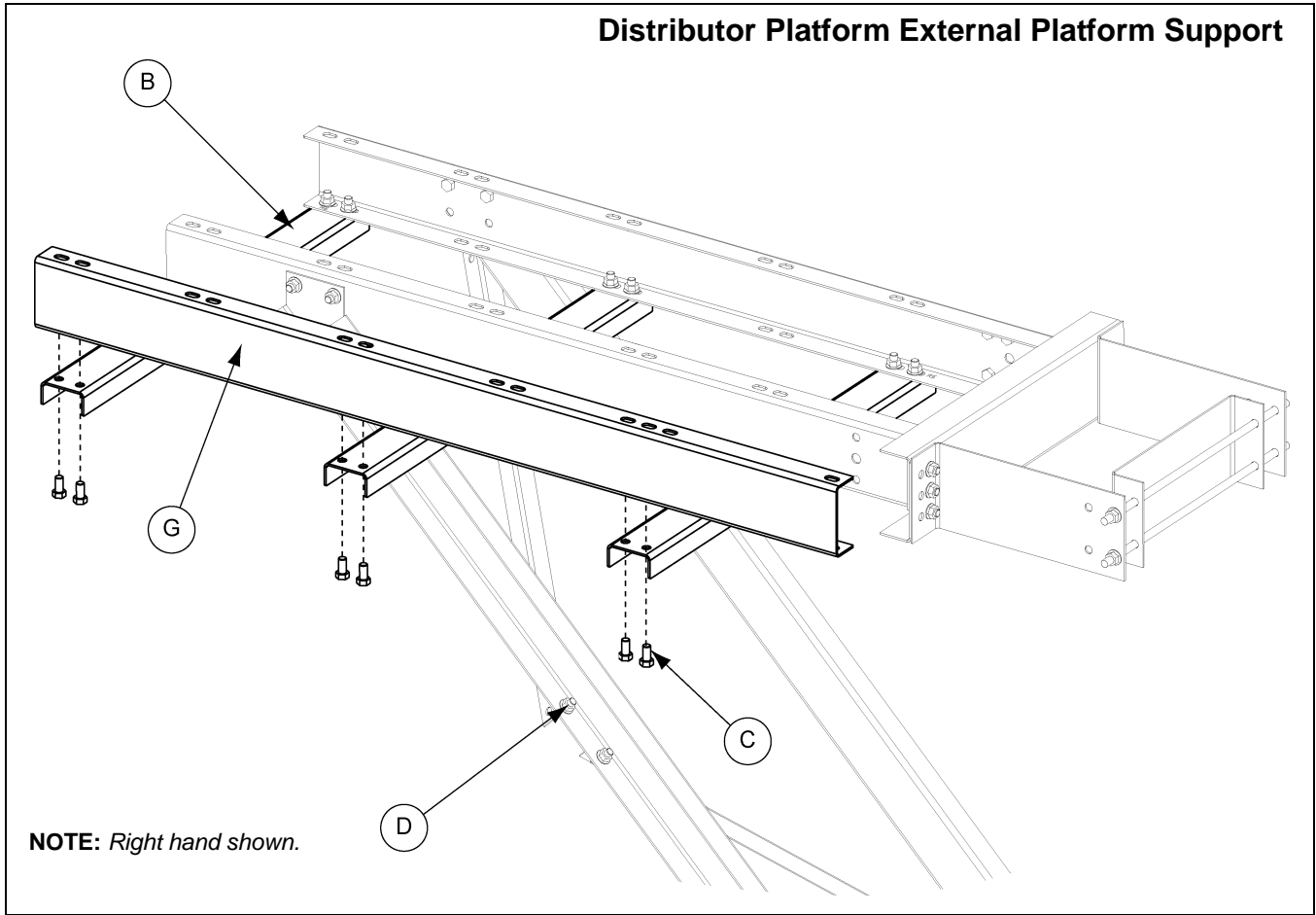

Figure 12C Distributor External Platform Support

Ref #	Part #	Description
B	DSP1648CS	Distributor Platform Cross Support
C	S-7935	1/2" x 1" Bolt
D	S-8506	1/2" Hex Flange Nut
G	DSP1648EPS	Distributor External Platform Support

Assemble Decking

1. Align A6 and A8 on platform decking weldment with A6 and A8 on the external platform supports.
2. Install platform decking weldment (GSB30141X) (A) to the platform support channels using twenty four (24) 1/2" x 1" bolt (S-7935) (C) and nuts (S-8506) (D). *(See Figure 12D.)*
3. Attach the flange of the toe board short side to the bottom of the 18" decking using two (2) 1/2" x 1" bolt (S-7935) (C) and nuts (S-8506) (D). Then attach 18" decking to the external platform support (DSP1648EPS) (B) using one 1/2" x 1" bolt (S-7935) (C) and nut (S-8506) (D). *(See Figure 12F on Page 103.)*
4. Align flange of end toe board along the bottom of decking. Connect end toe board to decking using 1/2" x 1" bolts and nuts (S-8506) (D). *(See Figure 12G on Page 104.)*
5. Install the corner "W" post at the same time as the toe board filler plate (GSB30142X) (H). Attach toe board filler plate (GSB30142X) (H) to the decking toe boards located across from the entrance. Attach the flat end first using two (2) 5/16" x 3/4" flange bolts (S-6606) (J) and nuts (S-3611) (K). Then line up the holes of the toe board filler plate (GSB30142X) (H) with the decking toe board, while also aligning the holes of the "W" post on the corner. Fasten all three (3) together with four (4) 5/16" x 3/4" flange bolts (S-6606) (J) and nuts (S-3611) (K). *(See Figure 12G on Page 104.)*

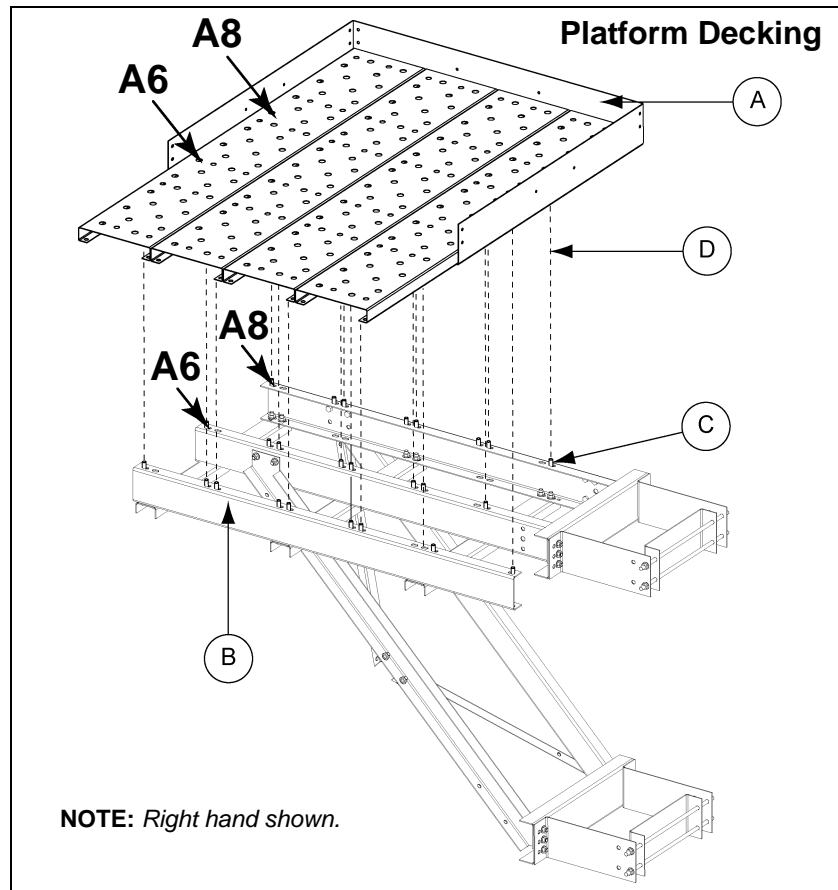
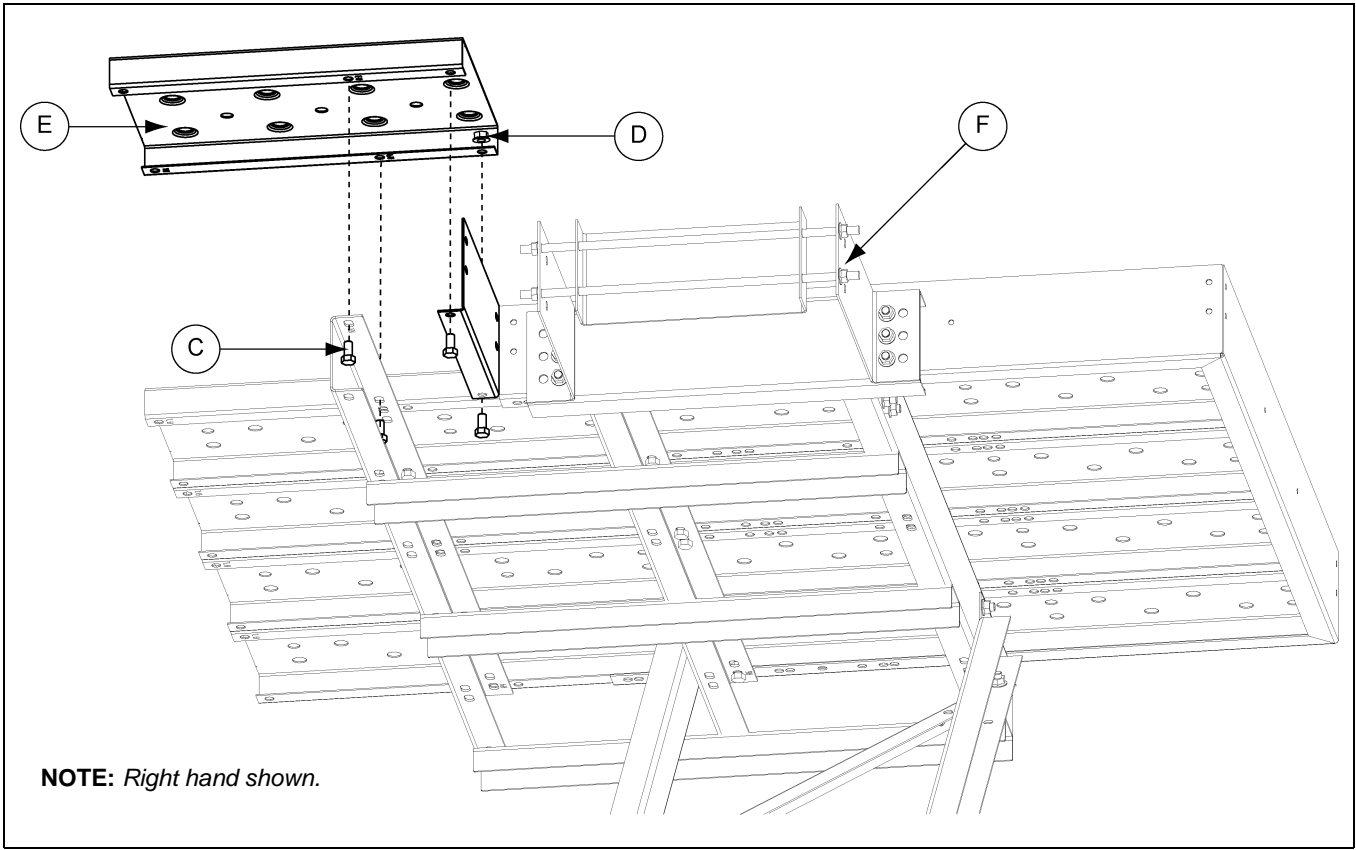

Figure 12D

Ref #	Part #	Description
A	GSB30141X	Platform Deck Weldment
B	DSP1648EPS	Distributor External Platform Support
C	S-7935	1/2" x 1" Bolt
D	S-8506	1/2" Hex Flange Nut

12. 4 x 5 Distributor Platform (Optional)

Assemble Decking (Continued)



NOTE: Right hand shown.

Figure 12E

Ref #	Part #	Description
C	S-7935	1/2" x 1" Bolt
D	S-8506	1/2" Hex Flange Nut
E	DSP1648DEX	18" Decking
F	GSB36256	Toe Board Short Side

Assemble Decking (Continued)

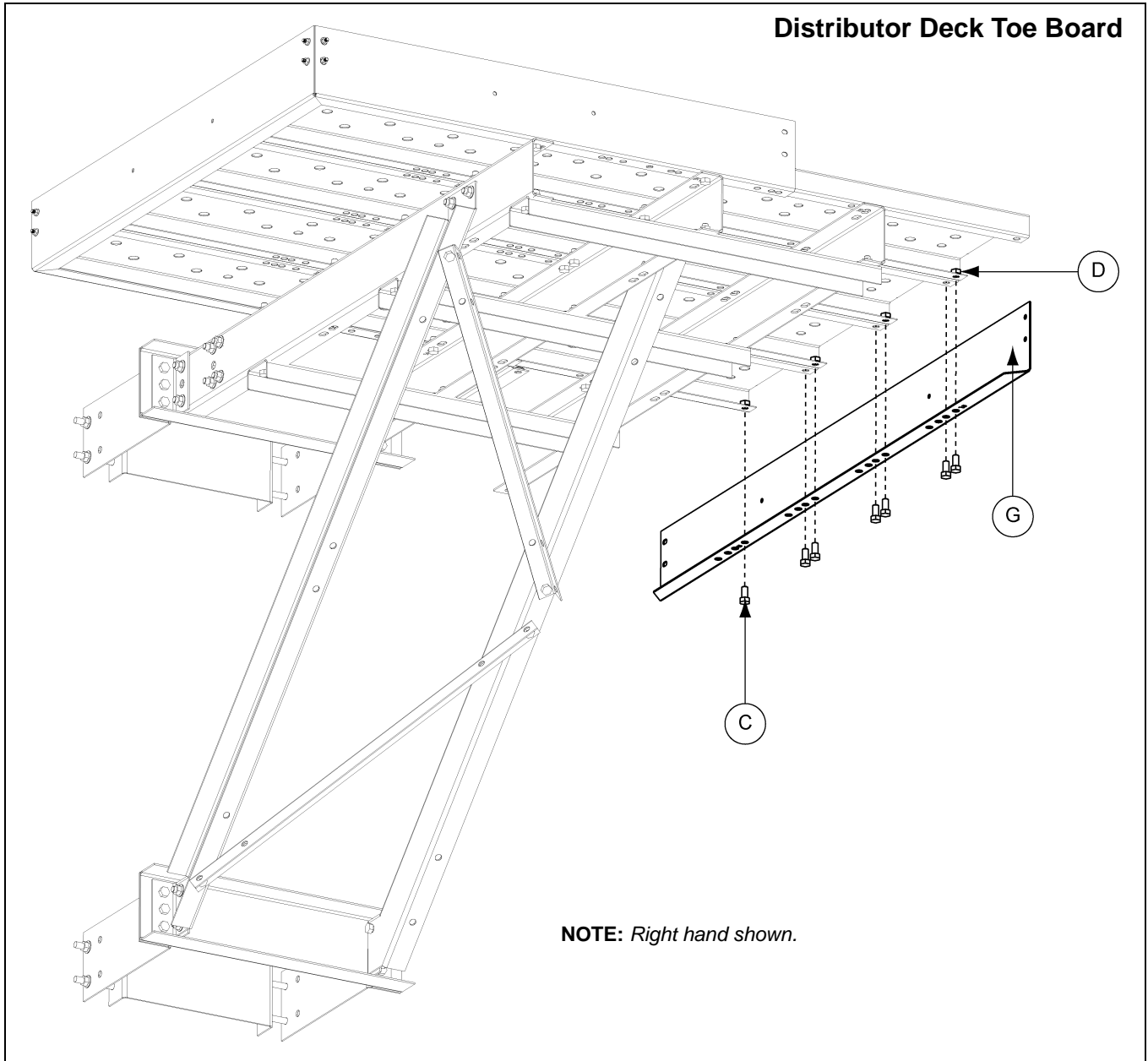

Figure 12F Distributor Platform Toe Board

Ref #	Part #	Description
C	S-7935	1/2" x 1" Bolt
D	S-8506	1/2" Flange Nut
G	GSB30136X	End Toe Board

12. 4 x 5 Distributor Platform (Optional)

Assemble Decking (Continued)

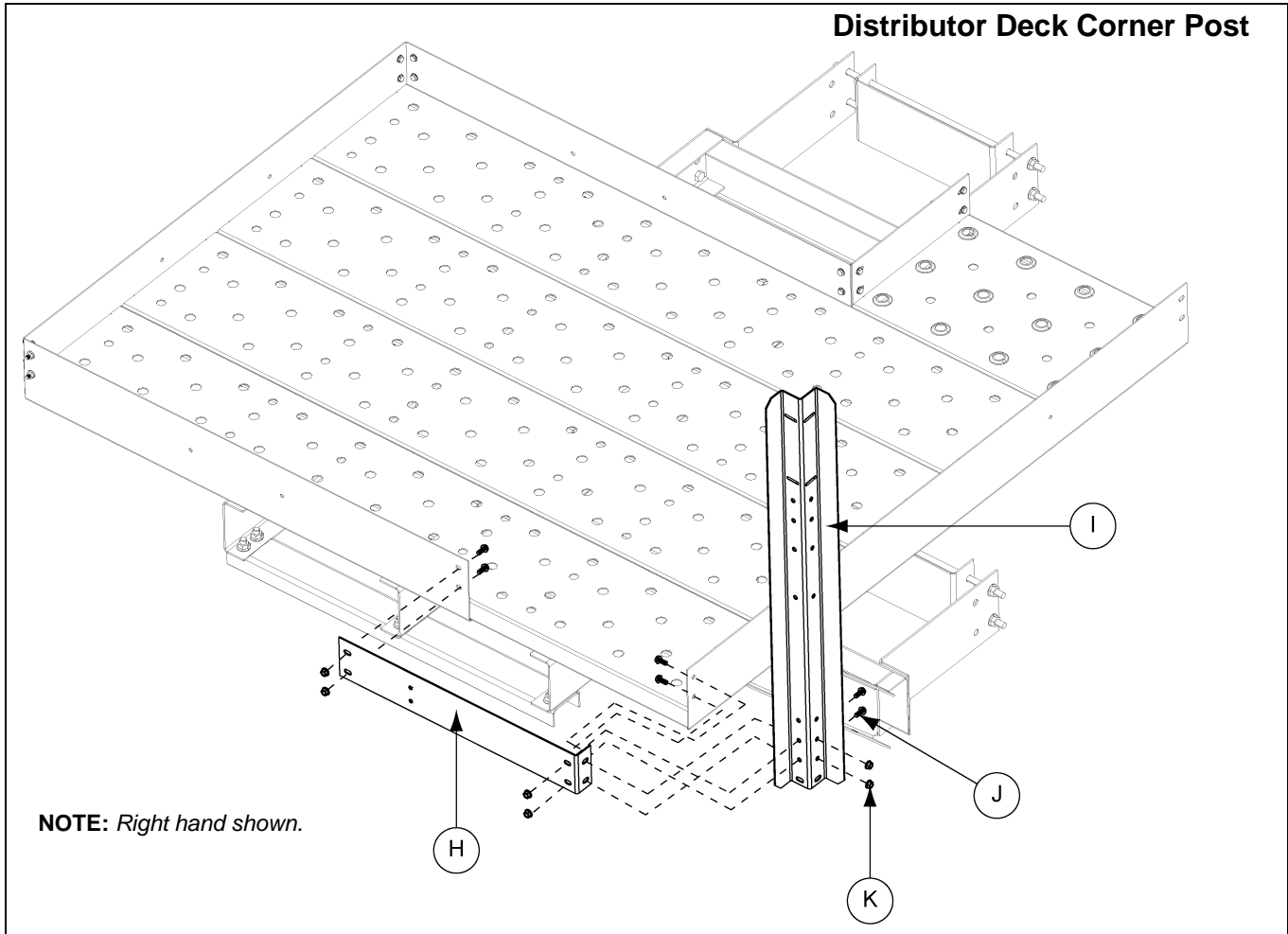

Figure 12G Distributor Platform Corner Post

Ref #	Part #	Description
H	GSB30142X	Toe Board Filler Plate
I	HP1648HWP	Head/Distributor "W" Post
J	S-6606	5/16" x 3/4" Flange Bolt
K	S-3611	5/16" Hex Flange Nut

Install Handrail Posts - Non Entrance Side

1. Install the remaining two (2) "W" corner posts to the corners on the non-entrance side of the decking using four (4) 5/16" x 3/4" flange bolts (S-6606) (E) and nuts (S-3611) (F) per post.
2. Install platform post (HP1648HCP) (D) to the inside corner of the decking near the entrance to the platform using four (4) 5/16" x 3/4" flange bolts (S-6606) (E) and nuts (S-3611) (F).
3. Attach side posts (HP1648HP) (A) to the decking at the entrance to the platform using two (2) 5/16" x 3/4" flange bolts (S-6606) (E) and nuts (S-3611) (F) per post.
4. Install distributor handrail support (DSP1648HS) (C) to the side post on the inside, located closest to the trunking through holes 3 and 4 counting from the top of the post. Use two (2) 5/16" x 3/4" flange bolts (S-6606) (E) and nuts (S-3611) (F) to fasten in place. (*See Figure 12H.*)

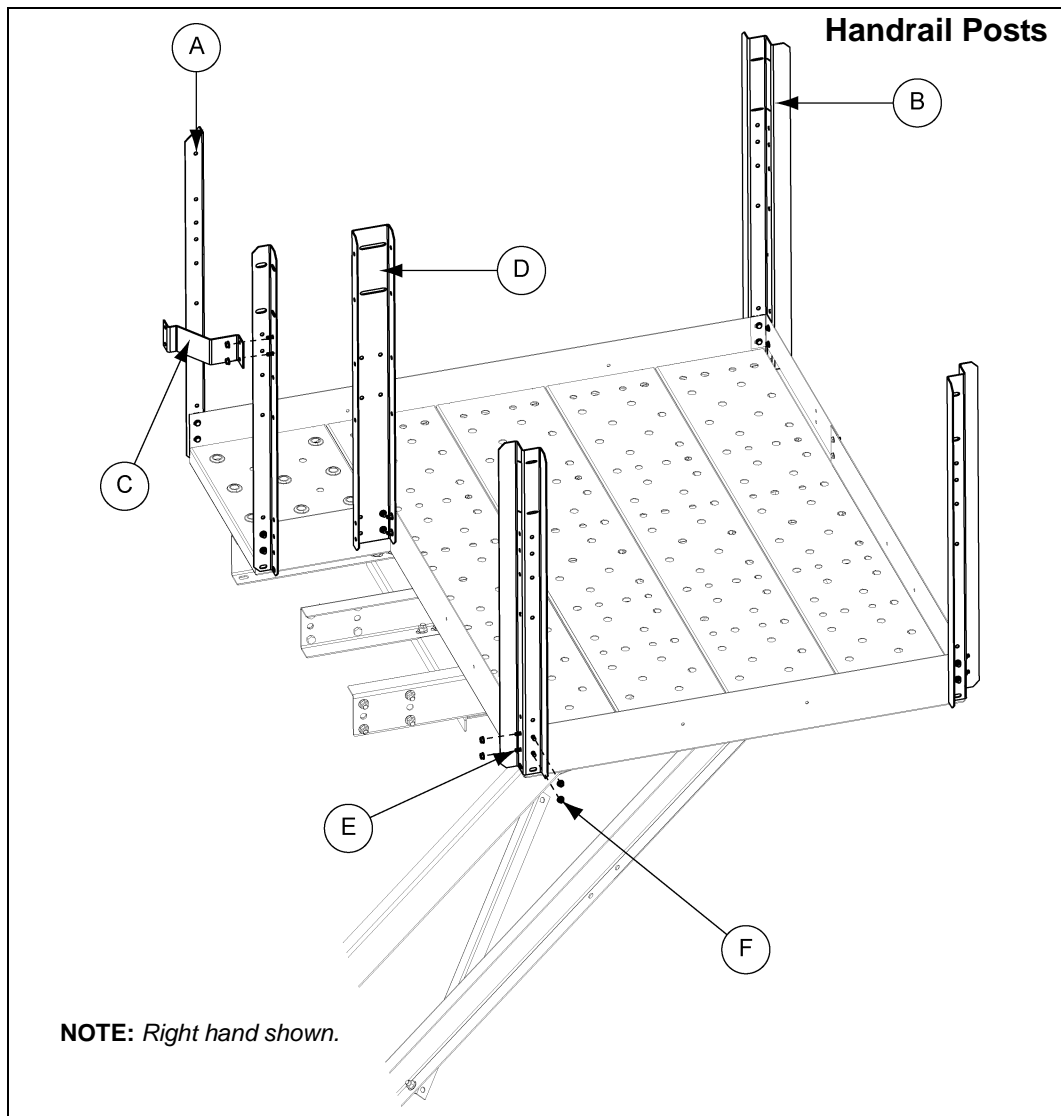

Figure 12H

Ref #	Part #	Description
A	HP1648HP	Head/Distributor Side Post
B	HP1648HWP	Head/Distributor "W" Post
C	DSP1648HS	Distributor Handrail Support

Ref #	Part #	Description
D	HP1648HCP	Platform Post
E	S-6606	5/16" x 3/4" Flange Bolt
F	S-3611	5/16" Flange Nut

12. 4 x 5 Distributor Platform (Optional)

Assemble and Install Intermediate Handrails

1. Insert small intermediate handrail (LDR-4087) (B) into the large intermediate handrails (LDR-4088) (A) to create telescoping rails. Cut 30" off one small intermediate and one large intermediate rail to fit at entrance. Adjust all rails to the proper length and install to the posts using the 5th hole down from the top. Fasten in place using two (2) 5/16" x 3/4" flange bolts (S-6606) (C) and nuts (S-3611) (D) per each telescoping tube. (See Figure 12I.)

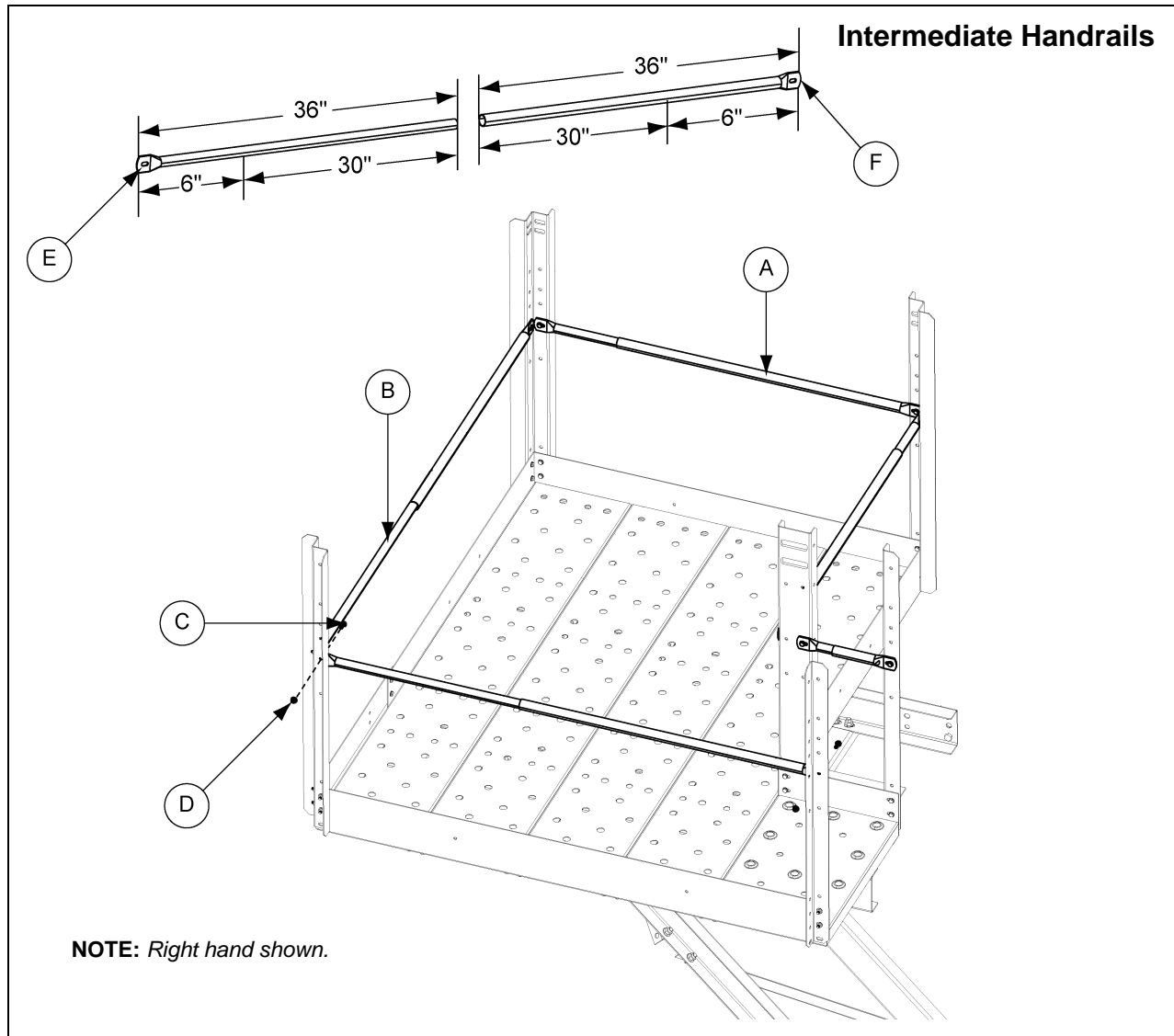

Figure 12I

Ref #	Part #	Description
A	LDR-4088	Large Intermediate Handrail
B	LDR-4087	Small Intermediate Handrail
C	S-6606	5/16" x 3/4" Flange Bolt
D	S-3611	5/16" Flange Nut
E		Cut Small Intermediate Rails
F		Cut Large Intermediate Rails

Install Safety Bar Cross Supports

NOTE: Safety cage bars (LDR-5171BE) (A) are used as tie braces in this installation.

1. Install safety bar cross supports from the decking toe board to the rail posts using two (2) 5/16" x 3/4" flange bolts (S-6606) (B) and nuts (S-3611) (C) per each cross bar support. (See Figure 12J.)

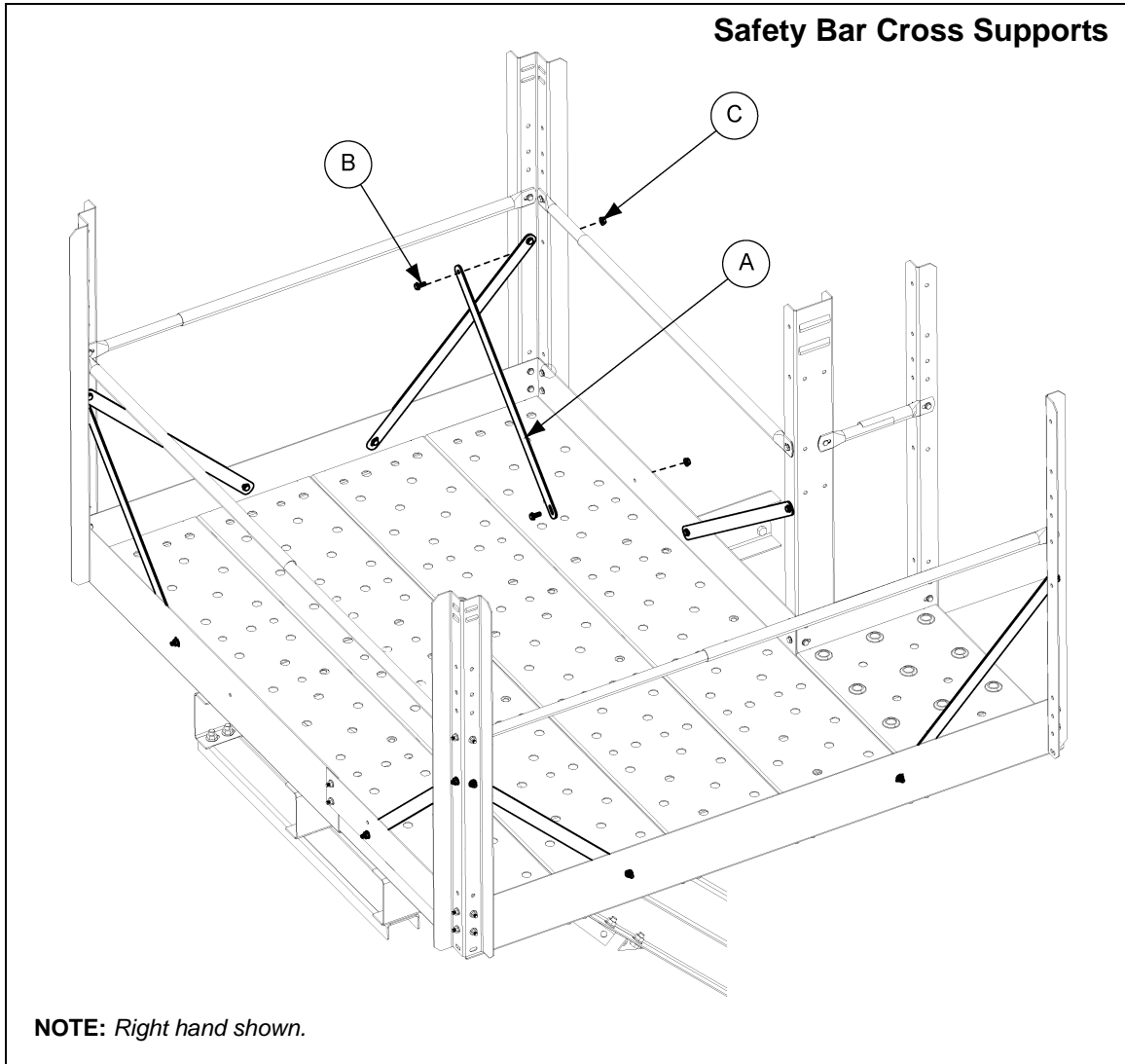

Figure 12J

Ref #	Part #	Description
A	LDR-5171BE	Braces
B	S-6606	5/16" x 3/4" Flange Bolt
C	S-3611	5/16" Flange Nut

12. 4 x 5 Distributor Platform (Optional)

Install Upper Handrails

1. Attach handrails to the posts using four (4) 5/16" x 3/4" flange bolts (S-7877) (B) and nuts (S-3611) (C) per handrail. (See Figure 12K.)

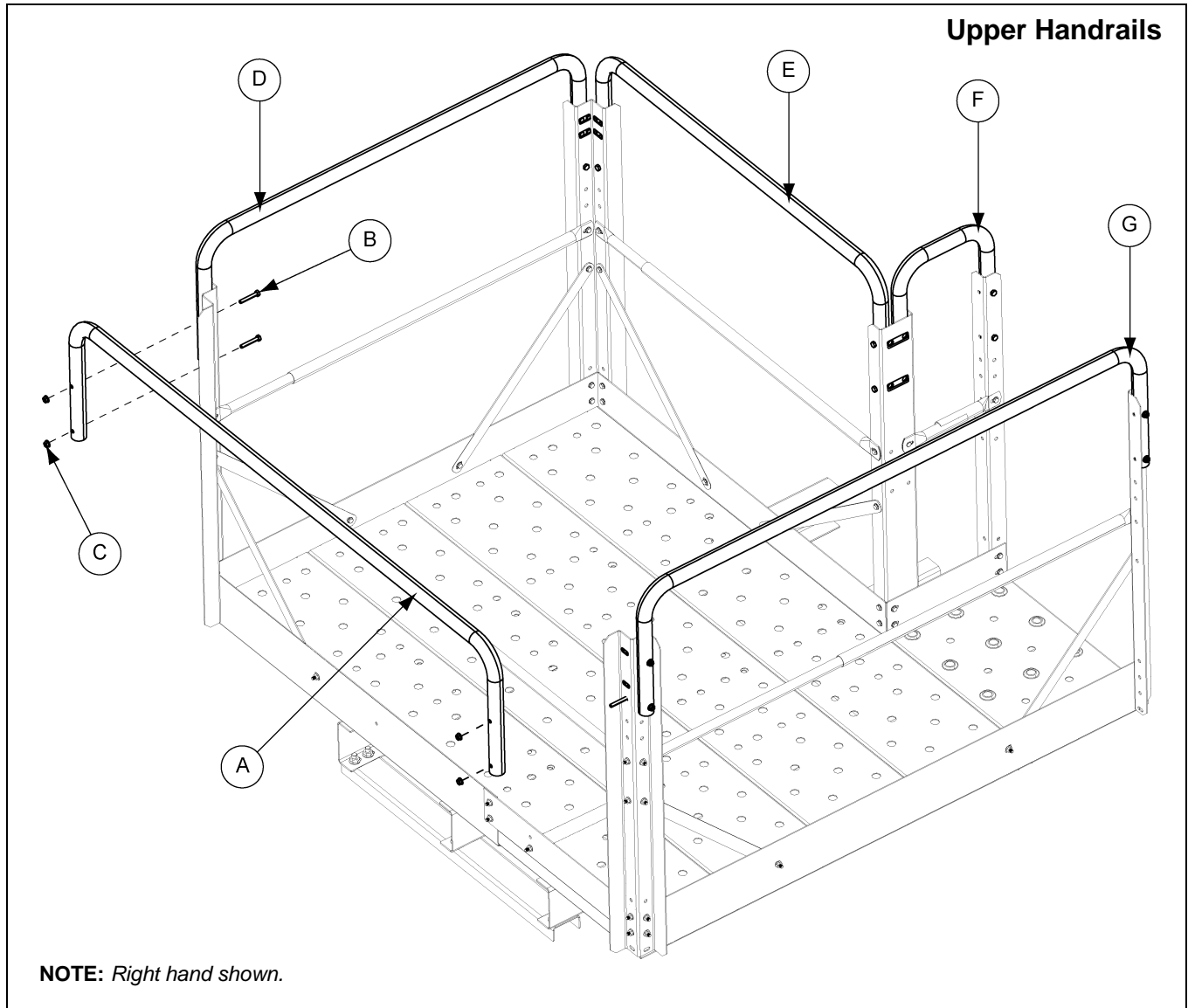

Figure 12K

Ref #	Part #	Description
A	HP1648HDH	64.126" Handrail
B	S-7877	5/16" x 2" Bolt
C	S-3611	5/16" Flange nut
D	DSP1648HIP	45.2" Handrail
E	DSP1648HNT	43.2" Handrail
F	DSP1648HSSG	10.5" Handrail
G	HP1624HFH	59.479" Handrail

Safety Gate Package (Optional)

IMPORTANT: Attach the platform gate bracket to the gate before attaching it to the inside platform post using 5/16" hardware.

Attach safety gate assembly to intermediate platform door bracket using 5/16" bolt (S-1196) (A), 5/16" flat washer (S-845) (B) and 5/16" flange nut (S-3611) (C).

Attach intermediate platform door bracket to two (2) safety gate side posts (HP1648HP) using 5/16" bolt (S-1196) (A), 5/16" flat washer (S-845) (B) and 5/16" flange nut (S-3611) (C). (See Figure 12L.)

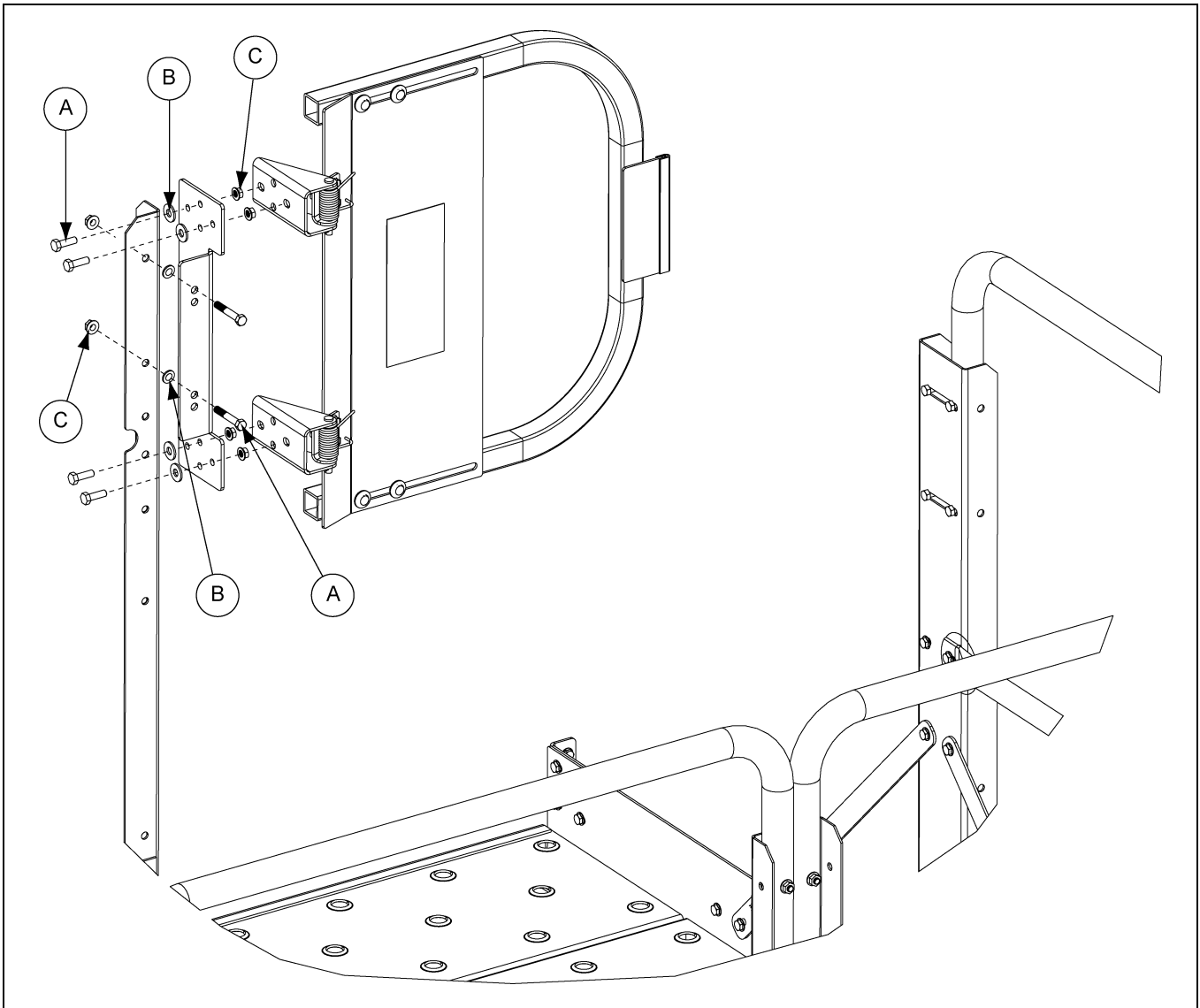

Figure 12L

Ref #	Part #	Description
A	S-1196	5/16" Bolt
B	S-845	5/16" Flat Washer
C	S-3611	5/16" Flange Nut

Chapter 13: 6 x 6 Distributor Platforms

This assembly is designed to be located at any elevation on trunking that is needed to provide access to other equipment. Determine elevation of platform surface and work from there. Locate all parts required for assembly by using the chart as shown in [Figure 13A](#).

Platform Clamps

Locate all clamp halves (DSP36007) (A), clamp brackets (DSP36016) (B), threaded rods (DSP36008) (C) and hardware to assemble clamps onto the trunking.

Measure the distance between the clamps to assure proper location for support channels and knee brace attachment. See clamp detail in [Figure 13A](#) for hardware orientation.

Attach one clamp half to the end of each platform support channel using 5/8" hardware in the top and bottom holes of the bracket.

Insert rod through the middle hole in the brackets attached to the platform support channel. Fasten using 5/8" nut, 5/8" lock washer and two (2) flat washers.

Place brackets with support channels attached around trunking and fasten in place with clamp bracket using 1/2" hardware.

Adjust the position of the inside nuts of the rod assembly to allow the clamps to be tightened onto the trunking.

NOTE: Tighten clamps onto trunking, do not overtighten and collapse the trunking. Position inside nuts back to the clamp and tighten.

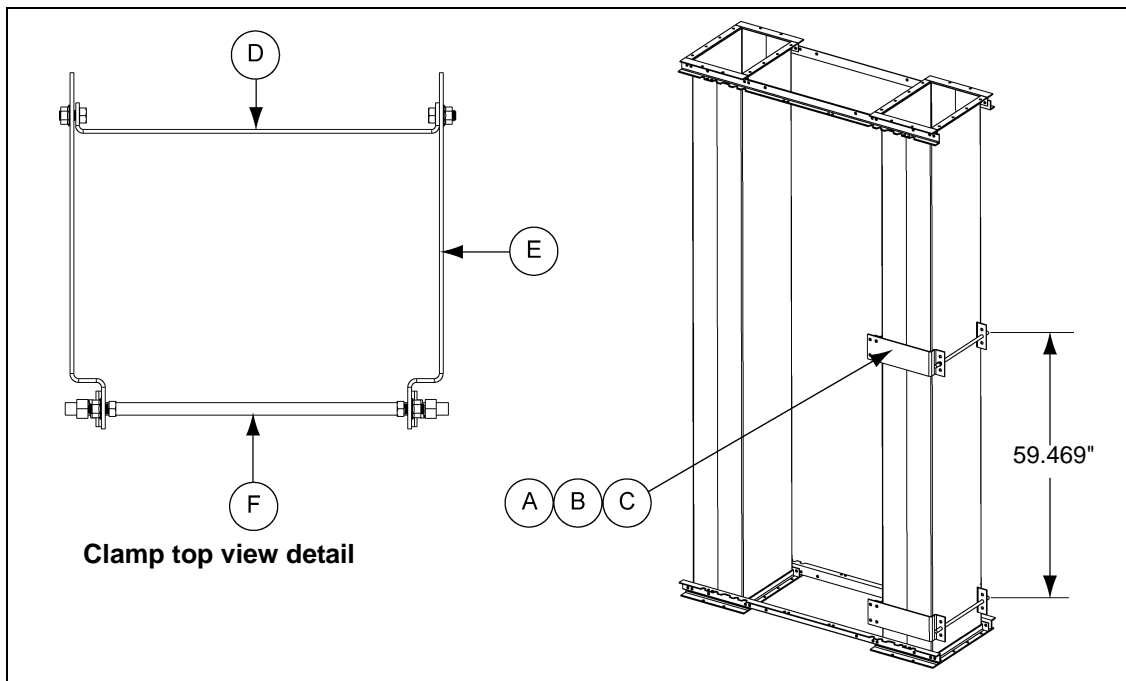

Figure 13A

Ref #	Part #	Description
30"/36" Single Trunking		
A	DSP36007	Clamp Halves (4)
B	DSP36016	Clamp Bracket (2)
C	DSP36008	Threaded Rods (2)
D		Clamp Bracket
E		Clamp Half Two (2)
F		Rod

Support Channels and Knee Braces

Assemble clamps securely to the trunk, attach the platform support channel (DSP36005) (B) to the upper clamp using 1/2" hardware (S-4492 and S-8506) (C and D).

Insert rod (DSP36008) through middle hole in the bracket, attached to the platform support channel (DSP36005) (B) using 5/8" hex nut (S-4110) (E), 5/8" lock washer (S-3208) (F) and two (2) 5/18" flat washers (S-858) (G). The knee braces will attach in the upper set of holes on side of support channels using 1/2" hardware (S-4492 and S-8506) (C and D). (See Figure 13B.)

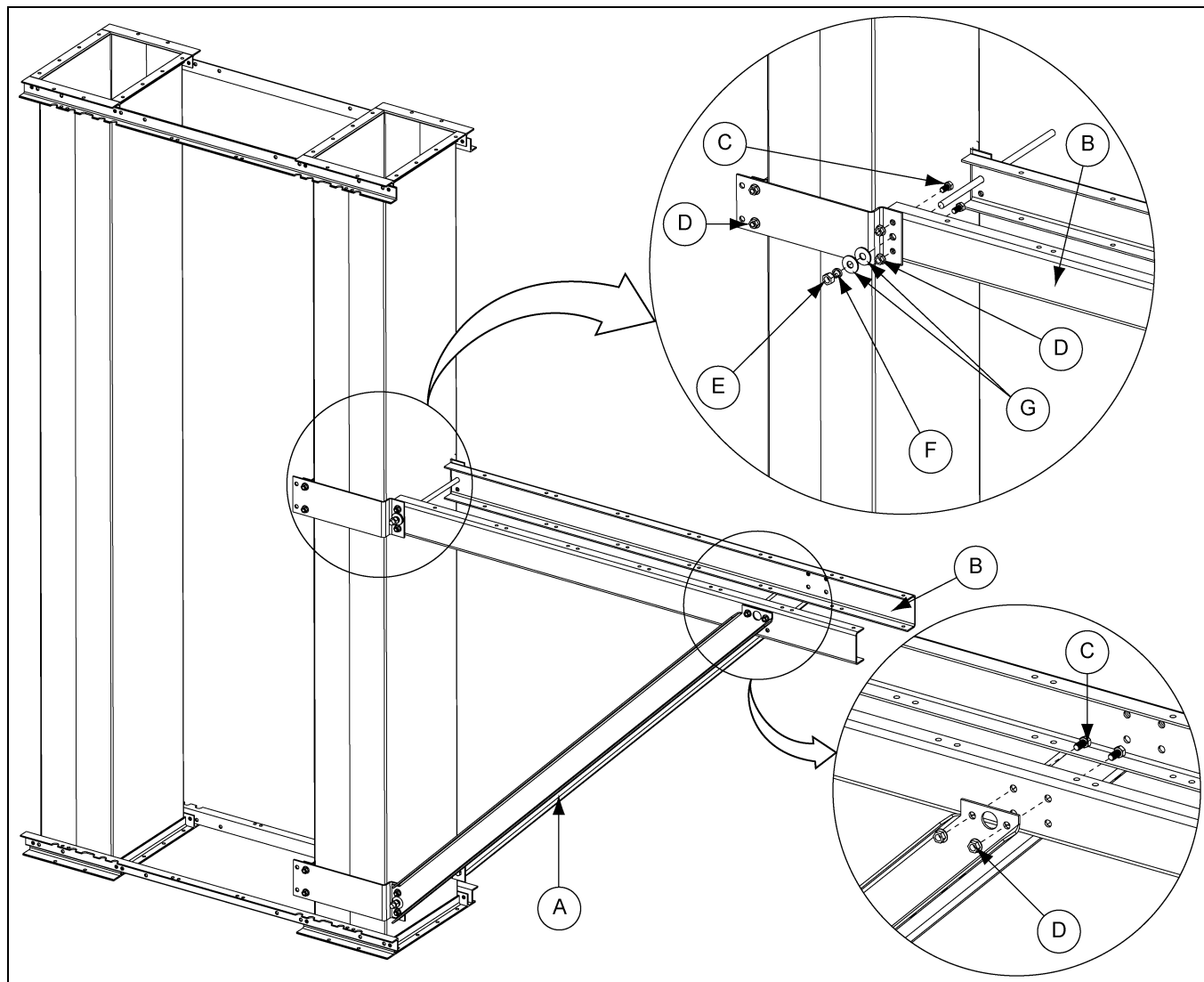

Figure 13B

Ref #	Part #	Description
A	DSP36006	Platform Knee Brace Channel (2)
B	DSP36005	Platform Support Channel (2)
C	S-4492	1/2" Bolt
D	S-8506	1/2" Flange Nut
E	S-4110	5/8" Hex Nut
F	S-3208	5/8" Lock Washer
G	S-858	5/8" Flat Washers

13. 6 x 6 Distributor Platforms

Toe Boards

With support assembly attached to trunk and hardware tightened, proceed by attaching the notched toe board angle (DSP36002X) (A) and toe board angle (DSP36003X) (B) to the top of the support channel using the 5/16" hardware provided. (Leave hardware loose.) (See Figure 13C.)

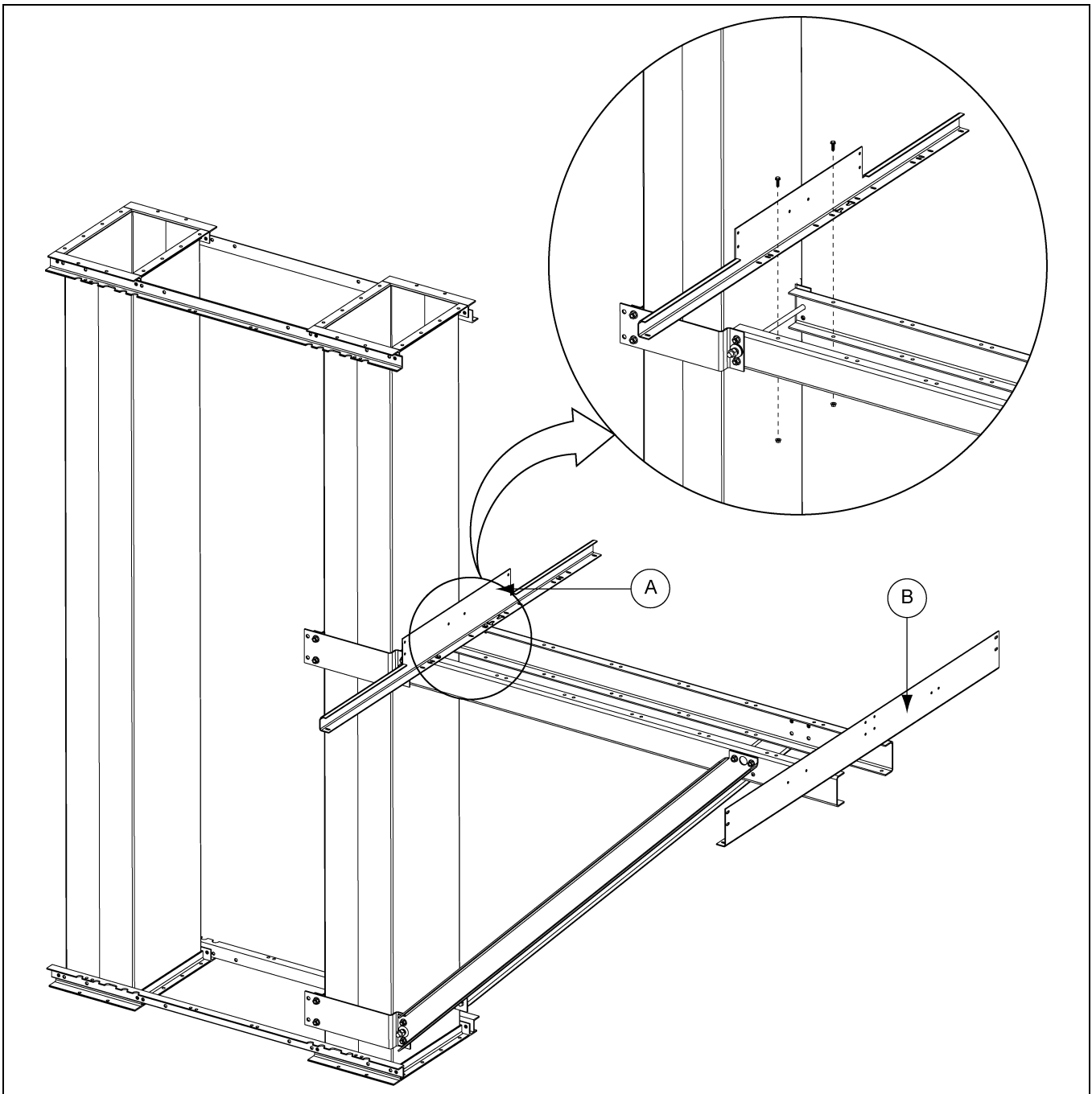

Figure 13C

Ref #	Part #	Description
A	DSP36002X	Notched Toe Board Angle
B	DSP36003X	Toe Board Angle

Cross Braces for Knee Braces

Attach knee brace diagonals to bottom side of the knee braces, this will add extra stability to the distributor platform. (See Figure 13D below and Figure 13E on Page 114.)

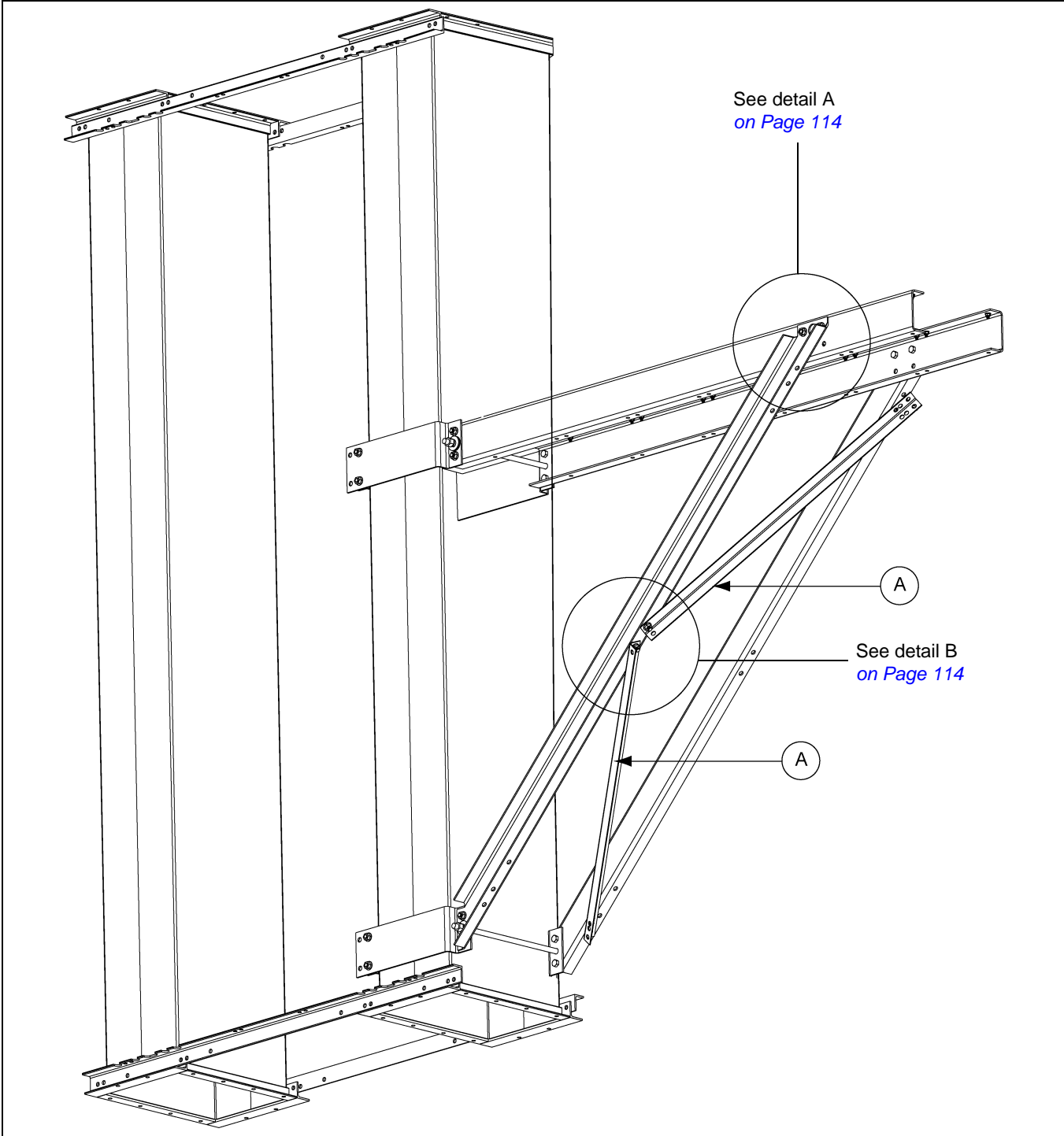

Figure 13D

Ref #	Part #	Description
A	DSP36015	36" DSP Support Strut

Cross Braces for Knee Braces (Continued)

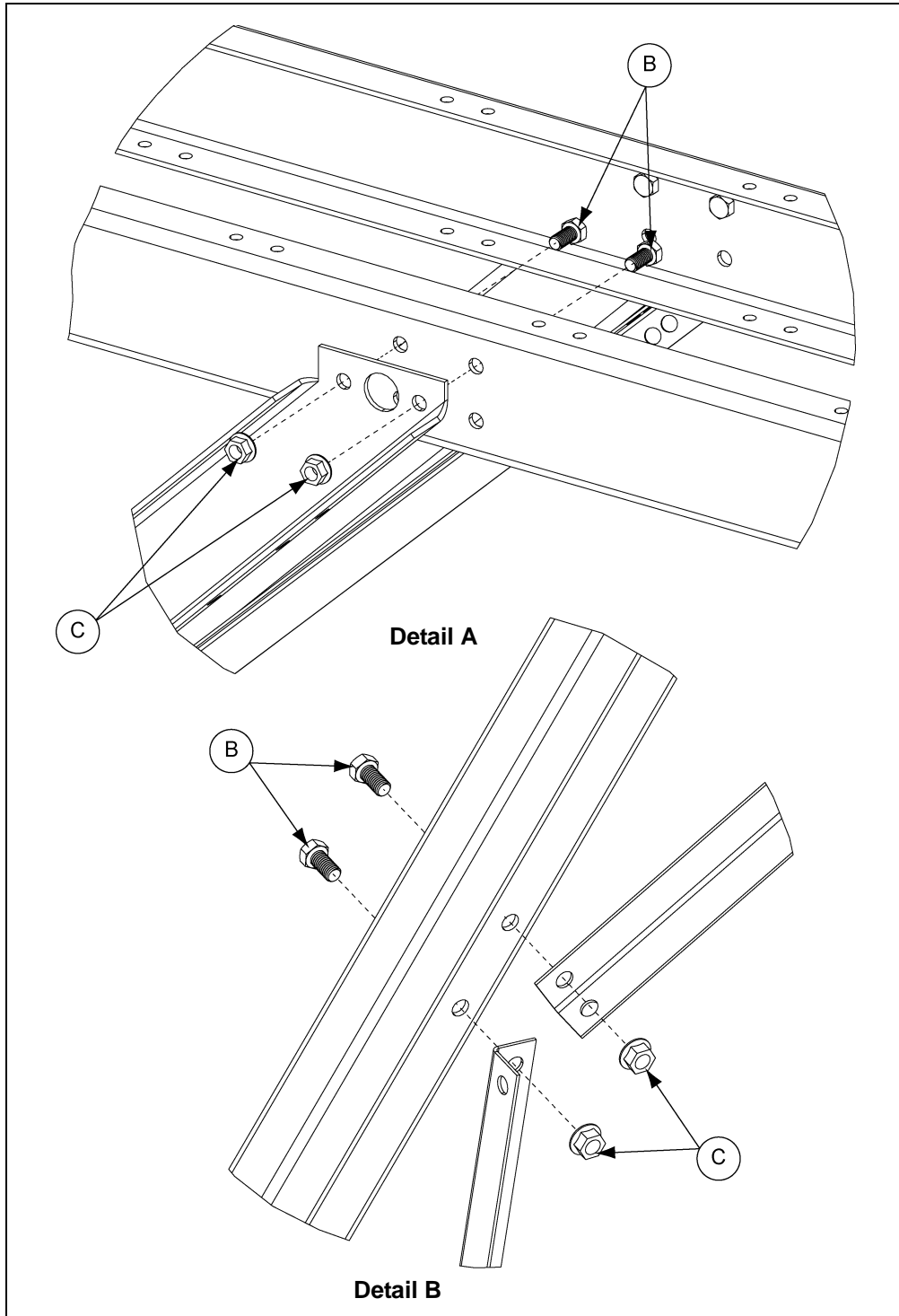

Figure 13E

Ref #	Part #	Description
B	S-4492	1/2" Bolt
C	S-8506	1/2" Flange Nut

Platform Decking

Attach the floor deck panels to the support channels. Then attach end toe boards (DSP36000X) (B) to the platform decking (DSP36004) (A) with the 5/16" hardware provided. Add extra toe board plates, after all pieces have been attached and positioned properly, tighten all hardware. (See Figure 13F below and Figure 13G on Page 116.)

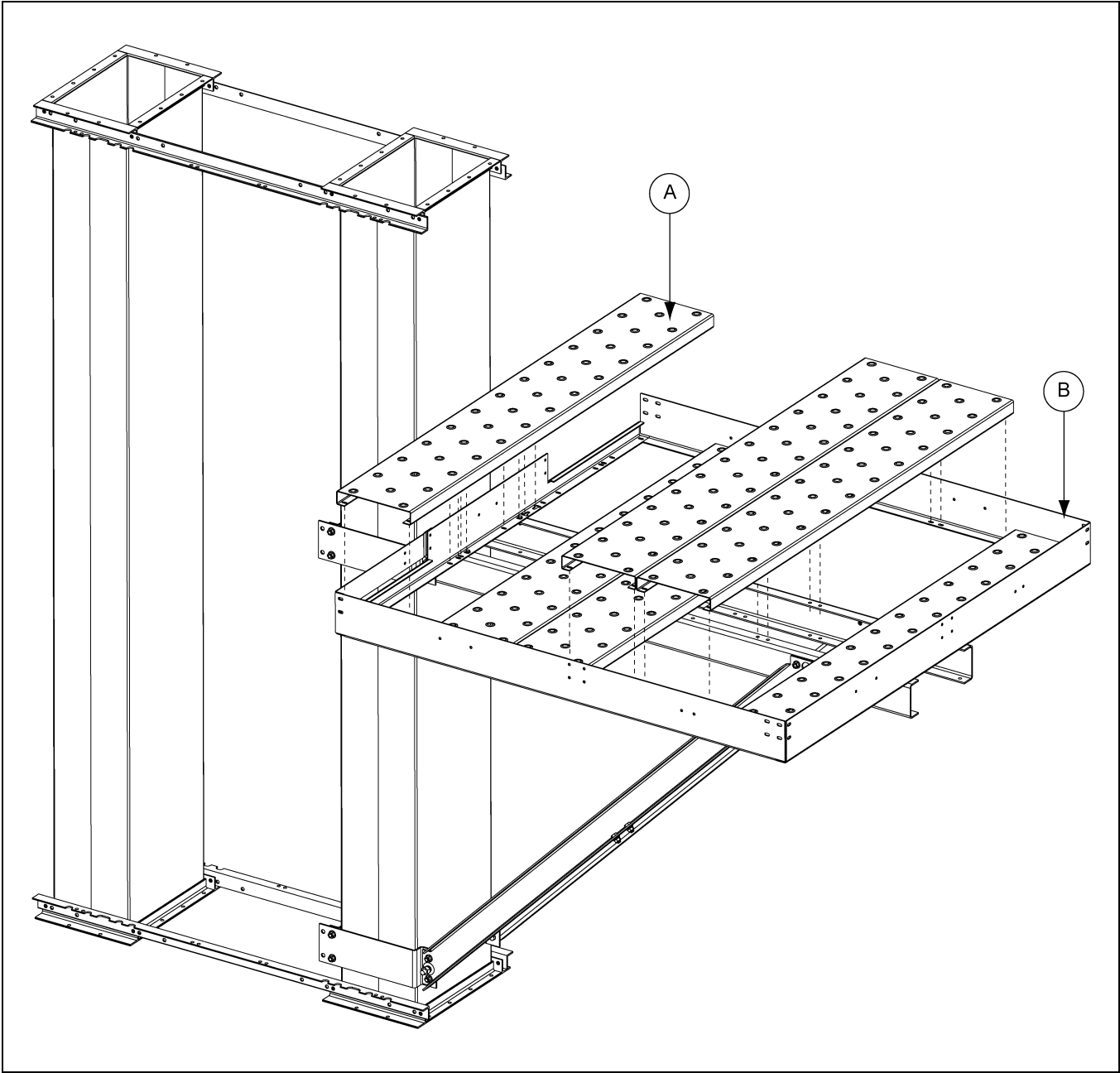

Figure 13F

Ref #	Part #	Description
A	DSP36004	Platform Decking (6)
B	DSP36000X	Toe Board Angle End (2)

Platform Decking (Continued)

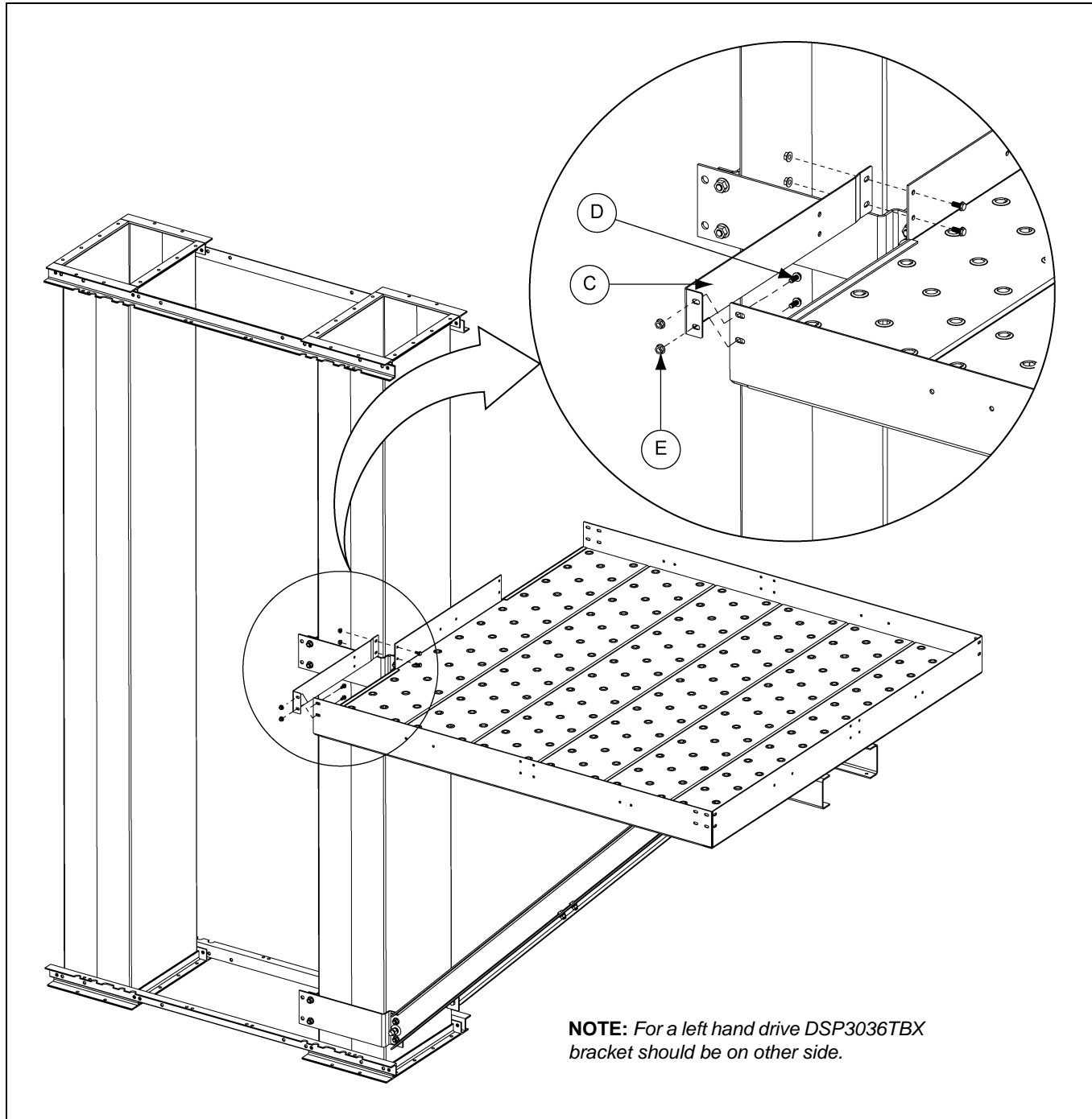

Figure 13G

Ref #	Part #	Description
C	DSP3036TBX	6 x 6 Large DSP Filler Toe Board
D	S-6606	5/16" Flange Bolt
E	S-3611	5/16" Flange Nut

Platform Post

Figure 13H shows the assembly of three (3) “W” corner posts (HP1648HWP) (C), three (3) platform posts (HP1648HCP) (B) and two (2) safety gate side posts (HP1648HP) (A). This must all be assembled using 5/16” hardware (S-6606 and S-3611) (D and E).

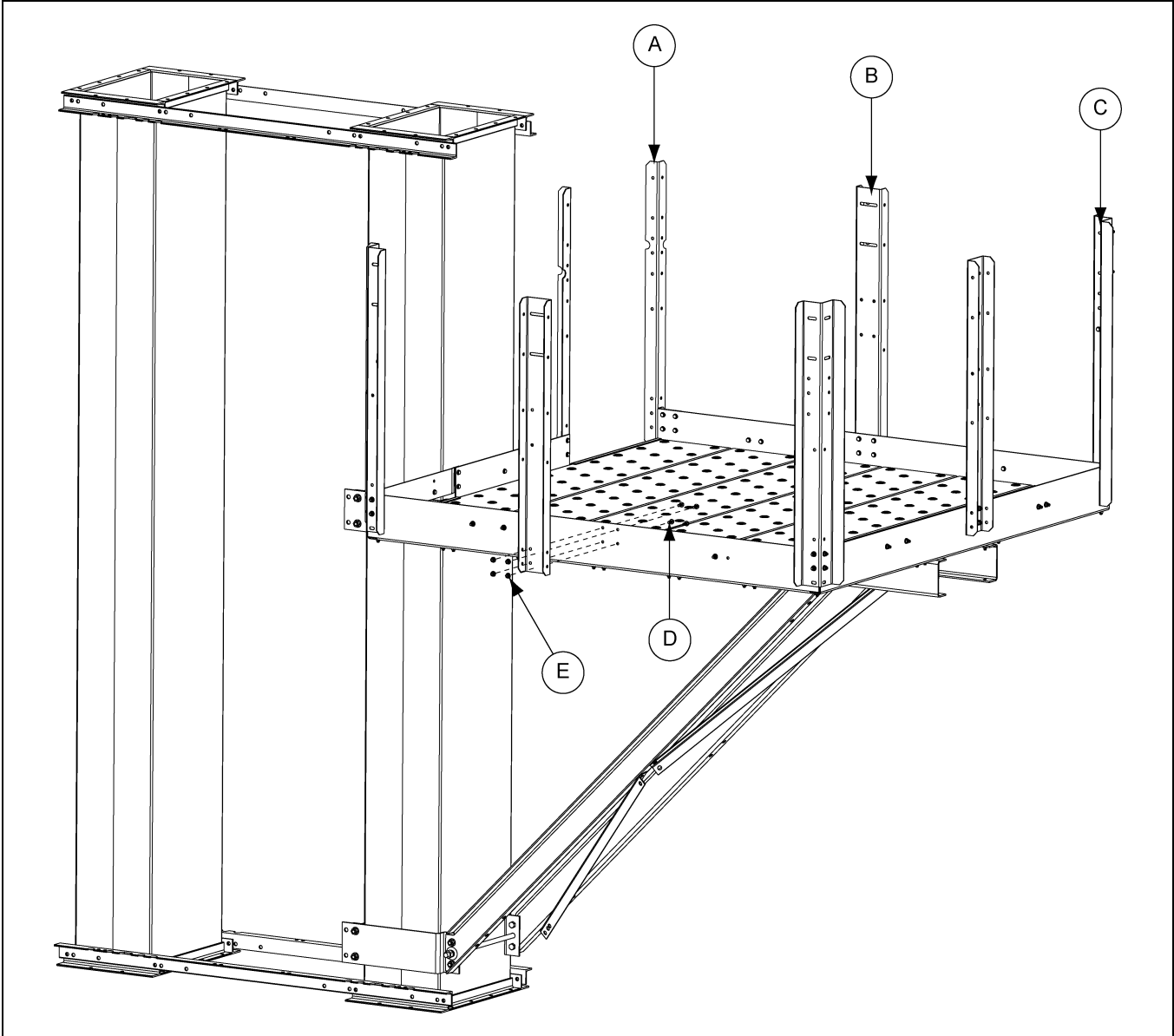

Figure 13H

Ref #	Part #	Description
A	HP1648HP	Safety Gate Side Post
B	HP1648HCP	Platform Post
C	HP1648HWP	“W” Corner Post
D	S-6606	5/16” Flange Bolt
E	S-3611	5/16” Flange Nut

13. 6 x 6 Distributor Platforms

Tie Braces

IMPORTANT: For safety purposes, make sure head of bolts are to the inside of platform with nuts on outside at all connections.

NOTE: Safety cage bars are used as tie braces in this installation.

Between each of the three (3) "W" corner posts (HP1648HWP), platform post (HP1648HCP) and safety gate side post (HP1648HP), attach two (2) tie braces (safety cage bar (LDR-5171BE)) from the lower half of the post to toe boards using 5/16"-18 x 3/4" ZN grade 5 bolts (S-6606) (A) and 5/16"-18 YDP grade 2 flange nut (S-3611) (B). (See Figure 13I.)

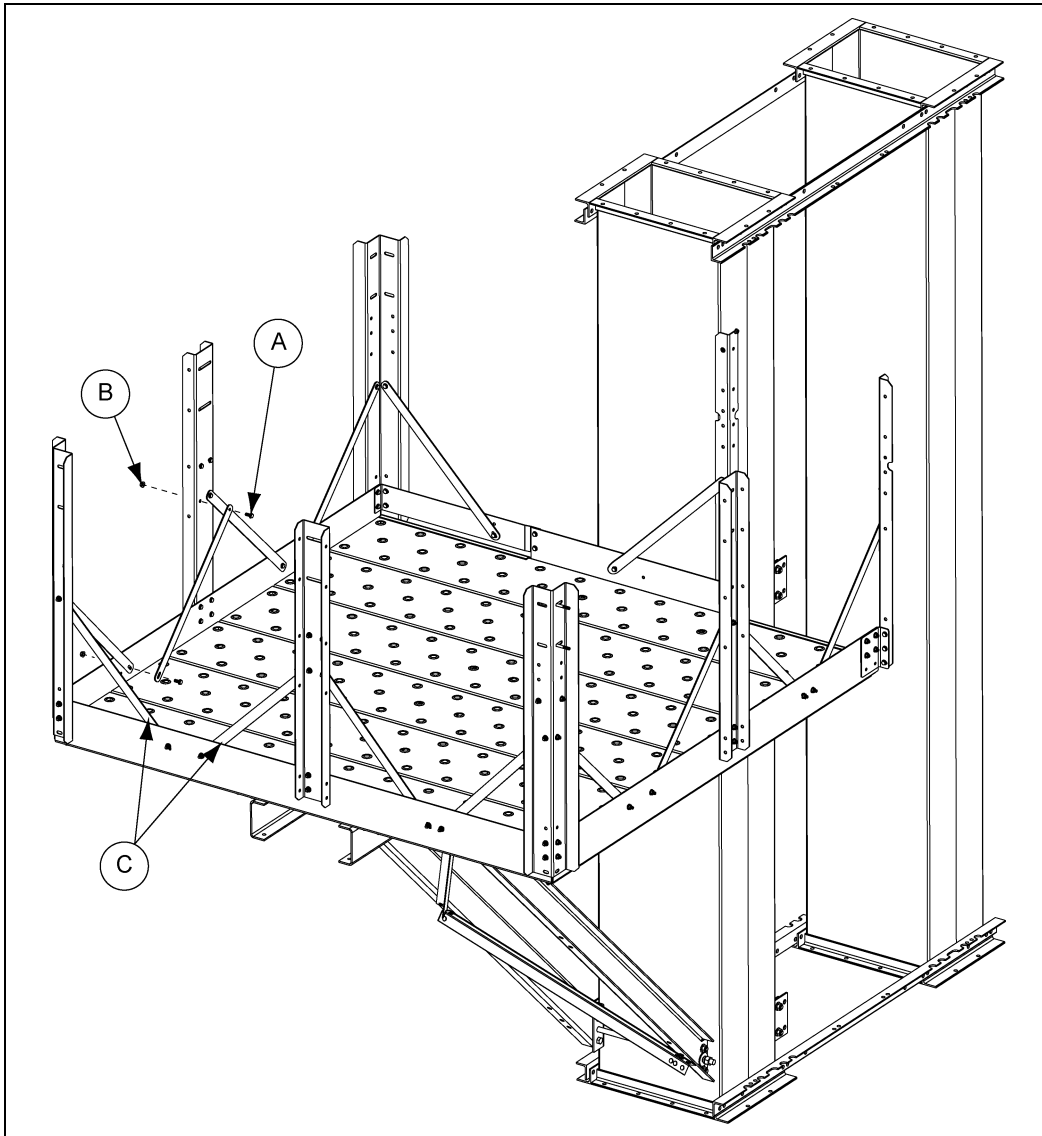

Figure 13I

Ref #	Part #	Description
A	S-6606	5/16" Flange Bolt
B	S-3611	5/16" Flange Nut
C		Tie Braces

Intermediate Handrail

IMPORTANT: For safety purposes, make sure head of bolts are to the inside of platform with nuts on outside at all connections.

NOTE: The small intermediate handrail (LDR-4088) (A) fits inside of the large intermediate handrail (LDR-4087) (B). Identify and separate the large and small intermediate handrails.

Trim six (6) large and six (6) small rails by 14" each so that the remaining length of each rail, both small and large is 22". (See Figure 13J.)

1. Install these rails across the platform and the opposite side as shown in Figure 13J.
2. Insert one small rail inside of one large rail and telescope the joined rails from the "W" corner post to the platform post as shown in Figure 13J.
3. Attach to "W" post (corner post) and platform post using nuts (S-3611) (C) and bolts (S-6606) (D). Torque to standard specifications.

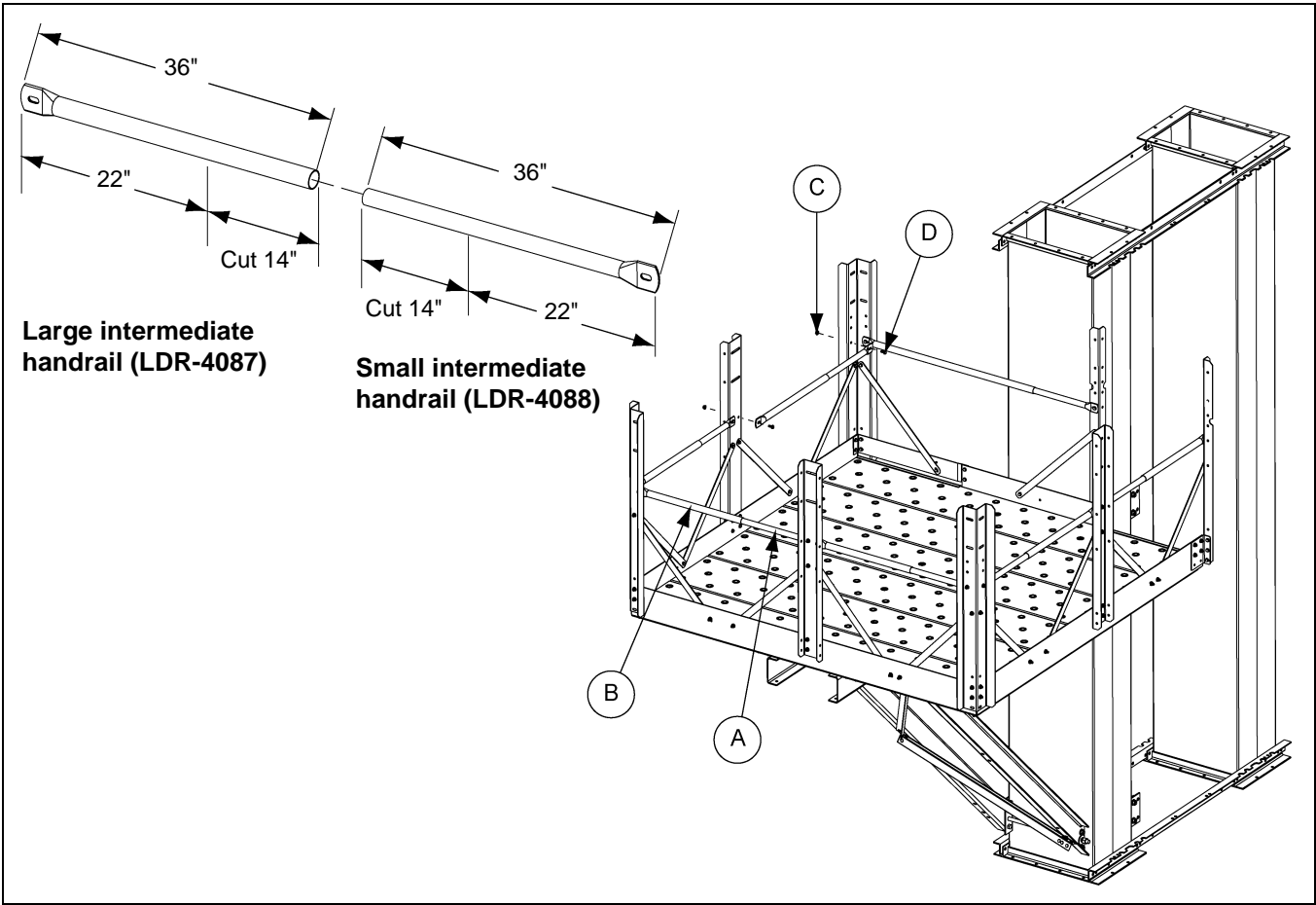

Figure 13J

Ref #	Part #	Description
A	LDR-4088	Small Intermediate Handrail
B	LDR-4087	Large Intermediate Handrail
C	S-3611	5/16" Flange Nut
D	S-6606	5/16" Flange Bolt

13. 6 x 6 Distributor Platforms

Upper Handrails

IMPORTANT: For safety purposes, make sure head of bolts are to the inside of platform with nuts on outside at all connections. (See Figure 13K.)

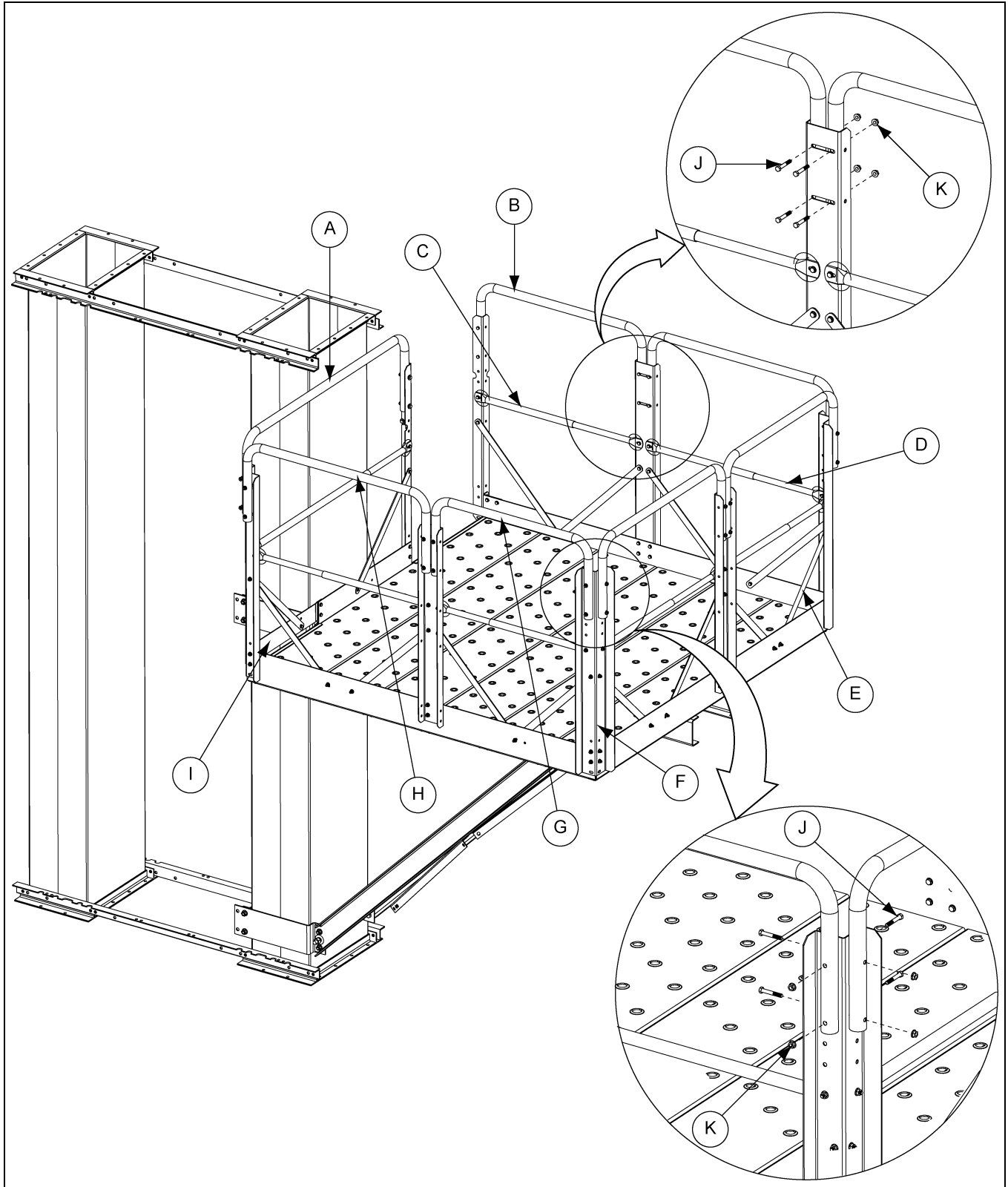

Figure 13K

Upper Handrails (Continued)

Attach hatch outside handrail (HP1648HLH) (H) from “W” corner post to platform post and right side handrail (DSP3036H31) (G) from platform post to next “W” corner post using 5/16" bolt (S-7877) (J) and 5/16" flange nut (S-3611) (K). (See Figure 13L.)

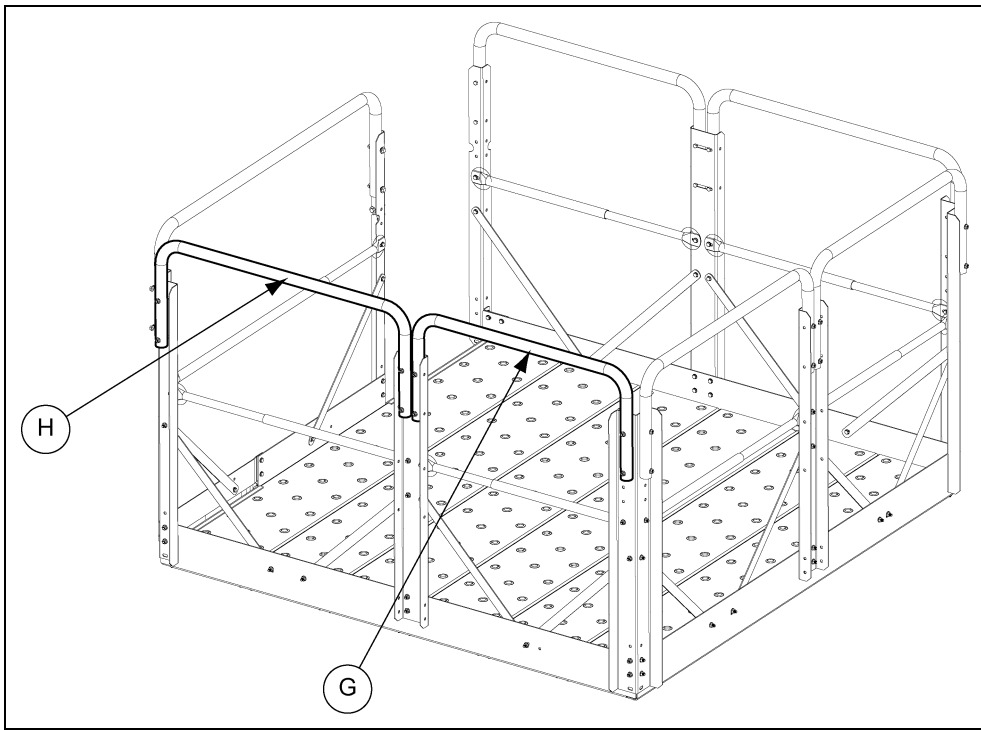

Figure 13L

Attach hatch outside handrail (HP1648HLH) (H) from “W” corner post to platform post and back side handrail (DSP3036H32) (B) from platform post to next “W” corner post using 5/16" bolt (S-7877) (J) and 5/16" flange nut (S-3611) (K). (See Figure 13M.)

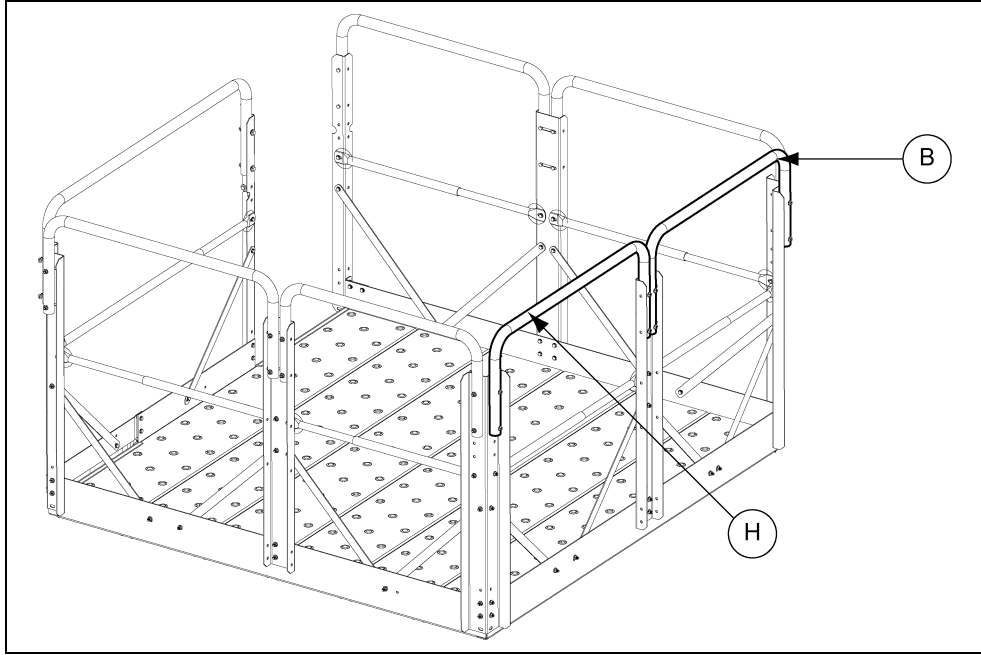

Figure 13M

13. 6 x 6 Distributor Platforms

Upper Handrails (Continued)

Attach hatch outside handrail (HP1648HLH) (H) from "W" corner post to platform post and back side handrail (DSP3036H32) (B) from platform post to next safety gate side post (HP1648HP) using 5/16" bolt (S-7877) (J) and 5/16" flange nut (S-3611) (K). (See Figure 13N.)

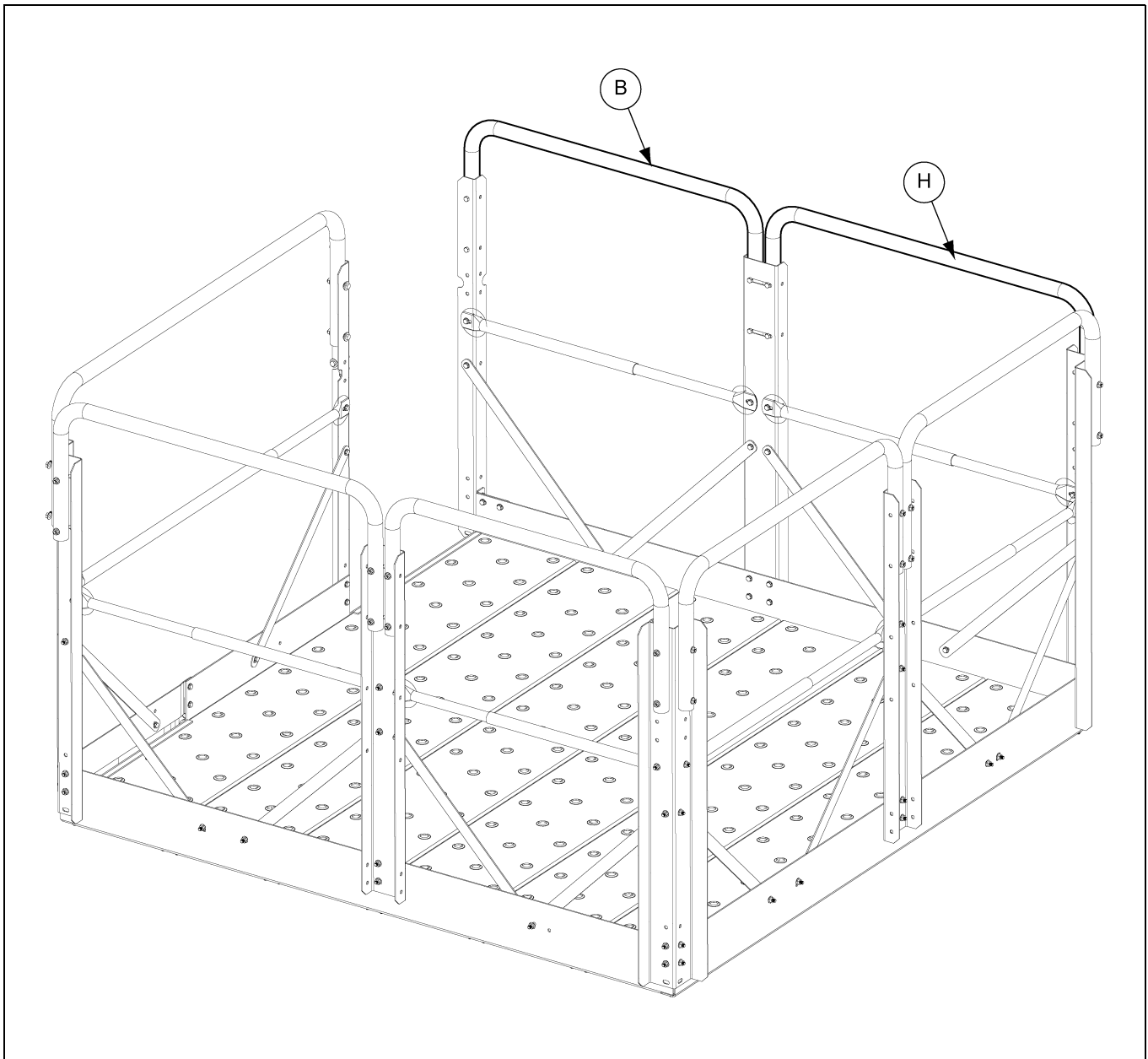

Figure 13N

Upper Handrails (Continued)

Attach drive handrail (HP1648HRD) (A) from “W” corner post to safety gate side post (HP1648HP) using 5/16" bolt (S-7877) (J) and 5/16" flange nut (S-3611) (K). (See Figure 130.)

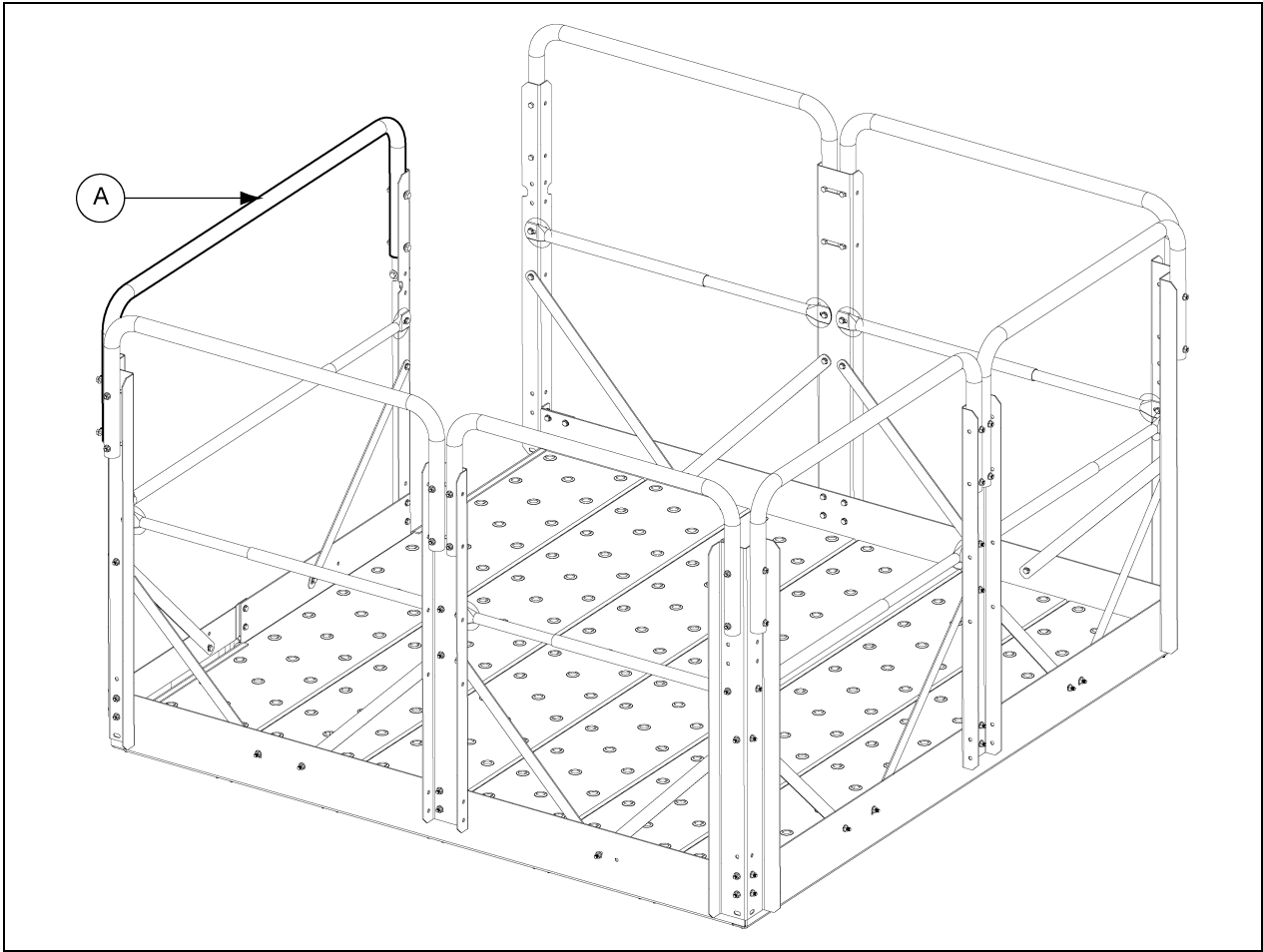

Figure 130

Ref #	Part #	Description
A	HP1648HRD	Drive 50-1/2" Outside Handrail (1)
B	DSP3036H32	DSP Back Side Handrail (2)
C	LDR-4087	Large Intermediate Handrail
D	LDR-4088	Small Intermediate Handrail
E	LDR-5171BE	Safety Cage Bar
F	HP1648HWP	“W” Corner Post
G	DSP3036H31	DSP Right Side Handrail (1)
H	HP1648HLH	Hatch Outside Handrail (3)
I	DSP3036TBX	Toe Board Plate
J	S-7877	5/16" Bolt
K	S-3611	5/16" Flange Nut

13. 6 x 6 Distributor Platforms

Safety Gate Package (If Ordered as Optional)

IMPORTANT: Attach the platform gate bracket to the gate before attaching it to the inside platform post using 5/16" hardware.

Attach safety gate assembly to intermediate platform door bracket using 5/16" bolt (S-1196) (A), 5/16" flat washer (S-845) (B) and 5/16" flange nut (S-3611) (C).

Attach intermediate platform door bracket to two (2) safety gate side posts (HP1648HP) using 5/16" bolt (S-1196) (A), 5/16" flat washer (S-845) (B) and 5/16" flange nut (S-3611) (C). (See Figure 13P below and Figure 13Q on Page 125.)

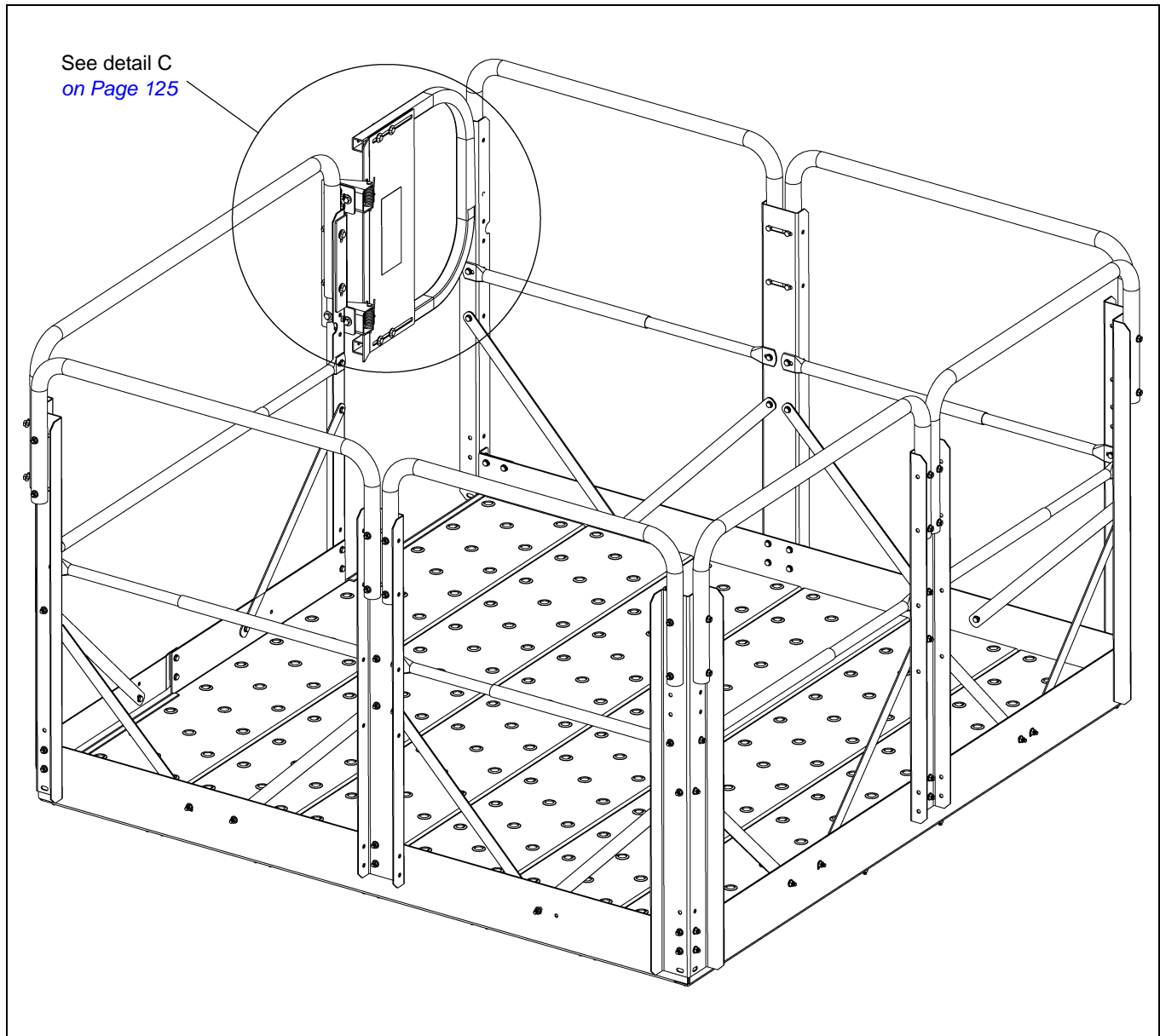

Figure 13P

Safety Gate Package (If Ordered as Optional) (Continued)

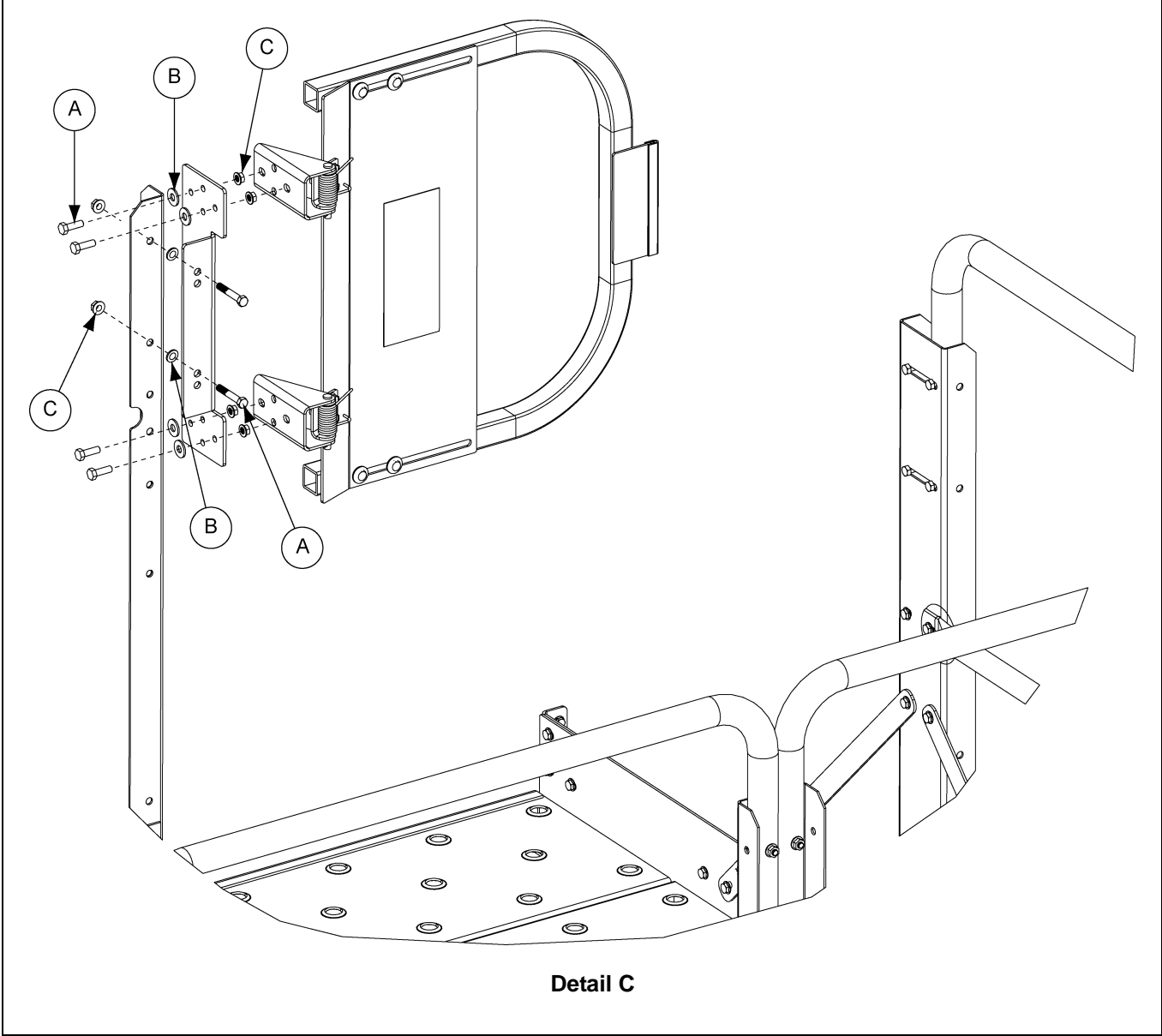

Figure 13Q

Ref #	Part #	Description
A	S-1196	5/16" Bolt
B	S-845	5/16" Flat Washer
C	S-3611	5/16" Flange Nut

NOTES

GSI Group, LLC Limited Warranty

The GSI Group, LLC ("GSI") warrants products which it manufactures to be free of defects in materials and workmanship under normal usage and conditions for a period of 12 months after sale to the original end-user or if a foreign sale, 14 months from arrival at port of discharge, whichever is earlier. The end-user's sole remedy (and GSI's only obligation) is to repair or replace, at GSI's option and expense, products that in GSI's judgment, contain a material defect in materials or workmanship. Expenses incurred by or on behalf of the end-user without prior written authorization from the GSI Warranty Group shall be the sole responsibility of the end-user.

Warranty Extensions:

The Limited Warranty period is extended for the following products:

	Product	Warranty Period	
AP Fans and Flooring	Performer Series Direct Drive Fan Motor	3 Years	* Warranty prorated from list price: 0 to 3 years - no cost to end-user 3 to 5 years - end-user pays 25% 5 to 7 years - end-user pays 50% 7 to 10 years - end-user pays 75%
	All Fiberglass Housings	Lifetime	
	All Fiberglass Propellers	Lifetime	
AP and Cumberland	Flex-Flo/Pan Feeding System Motors	2 Years	** Warranty prorated from list price: 0 to 3 years - no cost to end-user 3 to 5 years - end-user pays 50%
Cumberland Feeding/Watering Systems	Feeder System Pan Assemblies	5 Years **	
	Feed Tubes (1-3/4" and 2.00")	10 Years *	
	Centerless Augers	10 Years *	
	Watering Nipples	10 Years *	
Grain Systems	Grain Bin Structural Design	5 Years	† Motors, burner components and moving parts not included. Portable dryer screens included. Tower dryer screens not included.
Grain Systems Farm Fans Zimmerman	Portable and Tower Dryers	2 Years	
	Portable and Tower Dryer Frames and Internal Infrastructure †	5 Years	

GSI further warrants that the portable and tower dryer frame and basket, excluding all auger and auger drive components, shall be free from defects in materials for a period of time beginning on the twelfth (12th) month from the date of purchase and continuing until the sixtieth (60th) month from the date of purchase (extended warranty period). During the extended warranty period, GSI will replace the frame or basket components that prove to be defective under normal conditions of use without charge, excluding the labor, transportation, and/or shipping costs incurred in the performance of this extended warranty.

Conditions and Limitations:

THERE ARE NO WARRANTIES THAT EXTEND BEYOND THE LIMITED WARRANTY DESCRIPTION SET FORTH ABOVE. SPECIFICALLY, GSI MAKES NO FURTHER WARRANTY OF ANY KIND, EXPRESS OR IMPLIED, INCLUDING, WITHOUT LIMITATION, WARRANTIES OF MERCHANTABILITY OR FITNESS FOR A PARTICULAR PURPOSE OR USE IN CONNECTION WITH: (I) PRODUCT MANUFACTURED OR SOLD BY GSI OR (II) ANY ADVICE, INSTRUCTION, RECOMMENDATION OR SUGGESTION PROVIDED BY AN AGENT, REPRESENTATIVE OR EMPLOYEE OF GSI REGARDING OR RELATED TO THE CONFIGURATION, INSTALLATION, LAYOUT, SUITABILITY FOR A PARTICULAR PURPOSE, OR DESIGN OF SUCH PRODUCTS.

GSI shall not be liable for any direct, indirect, incidental or consequential damages, including, without limitation, loss of anticipated profits or benefits. The sole and exclusive remedy is set forth in the Limited Warranty, which shall not exceed the amount paid for the product purchased. This warranty is not transferable and applies only to the original end-user. GSI shall have no obligation or responsibility for any representations or warranties made by or on behalf of any dealer, agent or distributor.

GSI assumes no responsibility for claims resulting from construction defects or unauthorized modifications to products which it manufactured. Modifications to products not specifically delineated in the manual accompanying the equipment at initial sale will void the Limited Warranty.

This Limited Warranty shall not extend to products or parts which have been damaged by negligent use, misuse, alteration, accident or which have been improperly/inadequately maintained. This Limited Warranty extends solely to products manufactured by GSI.

Prior to installation, the end-user has the responsibility to comply with federal, state and local codes which apply to the location and installation of products manufactured or sold by GSI.

This equipment shall be installed in accordance with the current installation codes and applicable regulations, which should be carefully followed in all cases. Authorities having jurisdiction should be consulted before installations are made.



**1004 E. Illinois St.
Assumption, IL 62510-0020
Phone: 1-217-226-4421
Fax: 1-217-226-4420
www.gsiag.com**



GSI is a worldwide brand of AGCO Corporation.