



# V2 Electronic Distributor Control

## Installation and Operation Manual

PNEG-1895

Date: 09-19-13

GSI GROUP





## Contents

<b>Chapter 1 Safety</b> .....	<b>4</b>
Safety Guidelines .....	4
Safety Instructions .....	5
<b>Chapter 2 Decals</b> .....	<b>7</b>
<b>Chapter 3 Electrical Installation</b> .....	<b>8</b>
Introduction .....	8
Wire and Fitting Selection Requirements .....	8
Control Panel Cable to Distributor Fitting Connections .....	9
Motor Cable to Motor Junction Box Fitting Connections .....	10
Electric Motor Wiring Diagram .....	11
Motor Wiring Electrical Connections .....	12
Sensor Wiring Connections to Connector Box .....	13
Enclosure Covers Installation .....	14
Control Panel Installation Guidelines .....	15
Electric Motor Connections at Control Panel .....	16
Sensor Terminations in Control Panel .....	17
Power Supply Wiring to Control Panel Electrical Connections .....	18
<b>Chapter 4 Operation Procedures</b> .....	<b>19</b>
Initializing Screen .....	19
Start-Up Checklist .....	20
Main Screen .....	21
Move Position Screen .....	22
Setup Menu Screen .....	23
Help Menu Screen .....	32
Manual Override .....	36
<b>Chapter 5 Parts List</b> .....	<b>38</b>
12" 6 Hole 45° Distributor Assembly Electronic Control (DFB12645G-EC) .....	38
<b>Chapter 6 Retrofit Installation</b> .....	<b>40</b>
Electronic Distributor Control Shaft Installation .....	40
Electronic Distributor Enclosure Installation .....	41
Sensor Plate Angle and Proximity Sensor Bracket Installation .....	42
Proximity Sensor Location and Installation .....	43
Proximity Sensor Adjustment .....	45
Encoder and Bracket Installation .....	46
Installing the Connector Box and Cables .....	49
Motor Mounting Bracket Installation .....	50
Control Motor Installation .....	51
<b>Chapter 7 Troubleshooting</b> .....	<b>52</b>
Error Messages .....	52
Fault Code Descriptions, Possible Causes and Solutions .....	54
<b>Chapter 8 Schematic and Wiring Diagrams</b> .....	<b>57</b>
White Panel Layout .....	57
White Panel Electrical Schematic .....	58
<b>Chapter 9 Warranty</b> .....	<b>61</b>

### Safety Guidelines

This manual contains information that is important for you, the owner/operator, to know and understand. This information relates to protecting **personal safety** and **preventing equipment problems**. It is the responsibility of the owner/operator to inform anyone operating or working in the area of this equipment of these safety guidelines. To help you recognize this information, we use the symbols that are defined below. Please read the manual and pay attention to these sections. Failure to read this manual and its safety instructions is a misuse of the equipment and may lead to serious injury or death.



This is the safety alert symbol. It is used to alert you to potential personal injury hazards. Obey all safety messages that follow this symbol to avoid possible injury or death.



**DANGER** indicates a hazardous situation which, if not avoided, will result in death or serious injury.



**WARNING** indicates a hazardous situation which, if not avoided, could result in death or serious injury.



**CAUTION**, used with the safety alert symbol, indicates a hazardous situation which, if not avoided, could result in minor or moderate injury.



**NOTICE** is used to address practices not related to personal injury.

## Safety Instructions

Our foremost concern is your safety and the safety of others associated with this equipment. We want to keep you as a customer. This manual is to help you understand safe operating procedures and some problems that may be encountered by the operator and other personnel.

As owner and/or operator, it is your responsibility to know what requirements, hazards, and precautions exist, and to inform all personnel associated with the equipment or in the area. Safety precautions may be required from the personnel. Avoid any alterations to the equipment. Such alterations may produce a very dangerous situation where **SERIOUS INJURY** or **DEATH** may occur.

This equipment shall be installed in accordance with the current installation codes and applicable regulations, which should be carefully followed in all cases. Authorities having jurisdiction should be consulted before installations are made.

### Follow Safety Instructions

Carefully read all safety messages in this manual and safety signs on your machine. Keep signs in good condition. Replace missing or damaged safety signs. Be sure new equipment components and repair parts include the current safety signs. Replacement safety signs are available from the manufacturer.

Learn how to operate the machine and how to use controls properly. Do not let anyone operate without instruction.

Keep your machinery in proper working condition. Unauthorized modifications to the machine may impair the function and/or safety and affect machine life.

If you do not understand any part of this manual or need assistance, contact your dealer.

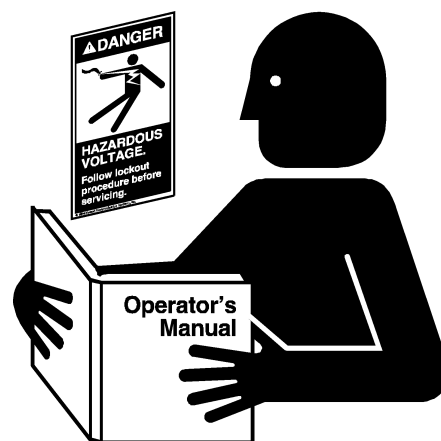

**Read and Understand Manual**

### Practice Safe Maintenance

Understand service procedures before doing work. Keep area clean and dry.

Never lubricate, service, or adjust machine while it is in operation. Keep hands, feet and clothing away from rotating parts.

Keep all parts in good condition and properly installed. Fix damage immediately. Replace worn or broken parts. Remove any built-up grease, oil, and debris.



**Maintain Equipment and Work Area**

# 1. Safety

## Prepare for Emergencies

Be prepared if fire starts.

Keep a first aid kit and fire extinguisher handy.

Keep emergency numbers for doctors, ambulance service, hospital, and fire department near your telephone.

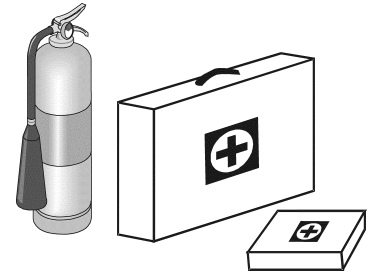

**Keep Emergency Equipment Quickly Accessible**

## Wear Protective Clothing

Wear close-fitting clothing and safety equipment appropriate to the job.

Remove all jewelry.

Tie long hair up and back.

Wear safety glasses at all times to protect eyes from debris.

Wear gloves to protect your hands from sharp edges on plastic or steel parts.

Wear steel-toed boots to help protect your feet from falling debris. Tuck in any loose or dangling shoestrings.

A respirator may be needed to prevent breathing potentially toxic fumes and dust.

Wear a hard hat to help protect your head.

Wear appropriate fall protection equipment when working at elevations greater than six feet (6').

**Eye Protection**

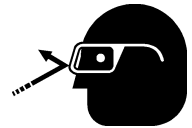

**Gloves**



**Steel-Toed Boots**



**Respirator**



**Hard Hat**



**Fall Protection**



The decals are located as shown below:

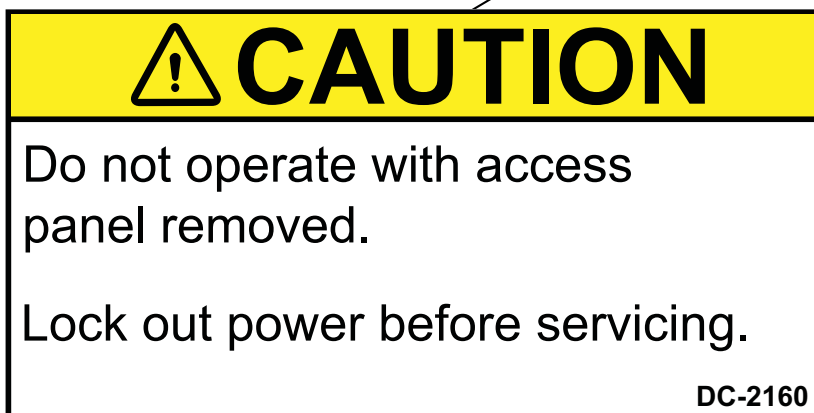
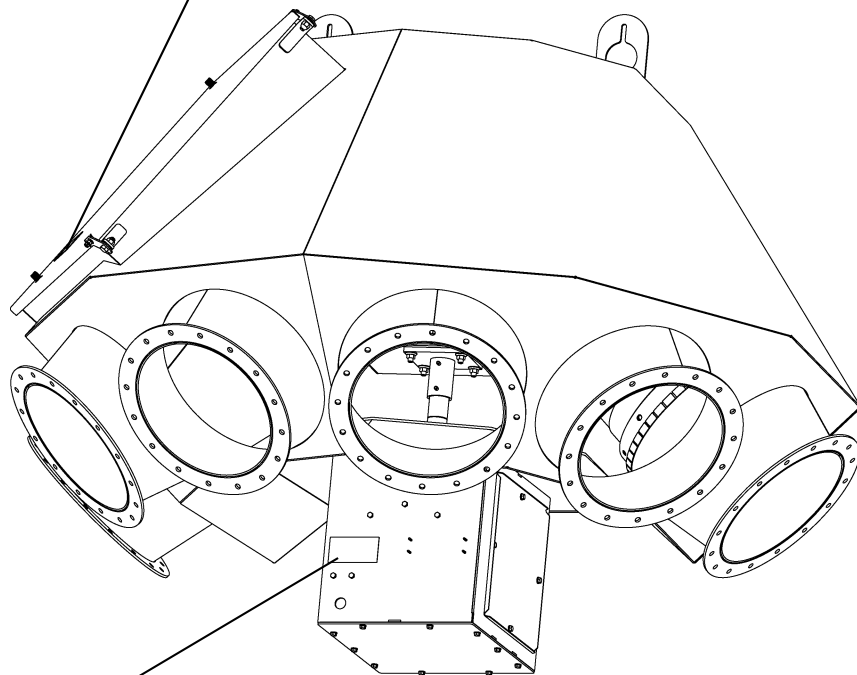
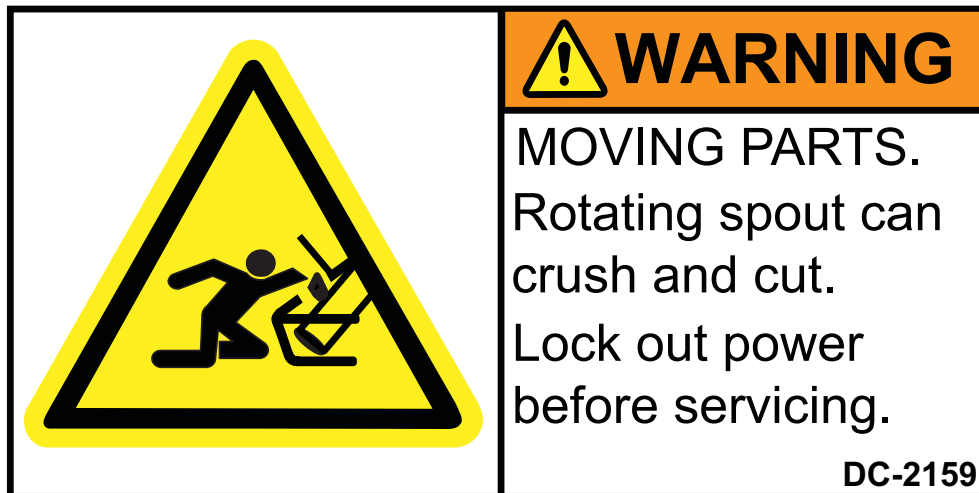

## 3. Electrical Installation

### Introduction

This section of the manual covers the electrical installation of your GSI electronically controlled distributor and controller assembly. If your installation is an electronic controller retrofit being installed on an existing GSI distributor, please begin with Section 6, Retrofit Installation [on Page 40](#) and return to this section after completion of mechanical component installation.

### Wire and Fitting Selection Requirements

**NOTE:** *The Sensor and VFD cables are supplied in 50' increments for a maximum length of 400'. The Sensor cable has one unterminated end and one end has a connector. The VFD cable is unterminated at both ends.*

All sensor wiring should be run in its own conduit and this conduit should be kept at least 6" away from other conduits. Any drain wires from shielded cable should be connected to ground in the panel.

VFD wiring should be run through appropriate conduit and the wiring for the motor must not be run in the same conduit as the wiring for the sensors.

All conduit and fittings should be outdoor rated to keep things adequately sealed, rigid conduit is required.

These shielding and conduit requirements **must** be followed for your GSI Electric Distributor Controller to function properly. Failure to follow these guidelines may result in damage to equipment or improper operation.



Figure 3A



## Control Panel Cable to Distributor Fitting Connections

Conduit for motor wiring should be run out of enclosure (DEC0005) (A) to the panel installed at ground level. Conduit for sensor wiring should be run from enclosure (DEC0005) (A) to panel installed at ground level. Appropriate fittings for conduit selection must be used at all connections. (See [Figure 3B](#).)



**Figure 3B** Cable Fitting Connections to Distributor Enclosure

Ref #	Part#	Description
A	DEC0005	Enclosure
B	DEC0026-XXX	Sensor Cable
B	DEC0025-XXX	VFD Cable

**NOTE:** "XXX" represents the length of the cable.

## Motor Cable to Motor Junction Box Fitting Connections

Remove the four (4) motor junction box cover screws (C) and the motor junction box cover (A) as shown in [Figure 3C](#).

Pull motor wiring through conduit to enclosure and feed to motor junction box (B) and through provided cord grip. Motor wiring should be routed within the enclosure to avoid close proximity to all sensor wiring. Motor wiring should be kept at least 4" from any sensor wires. ([See Figure 3C.](#))

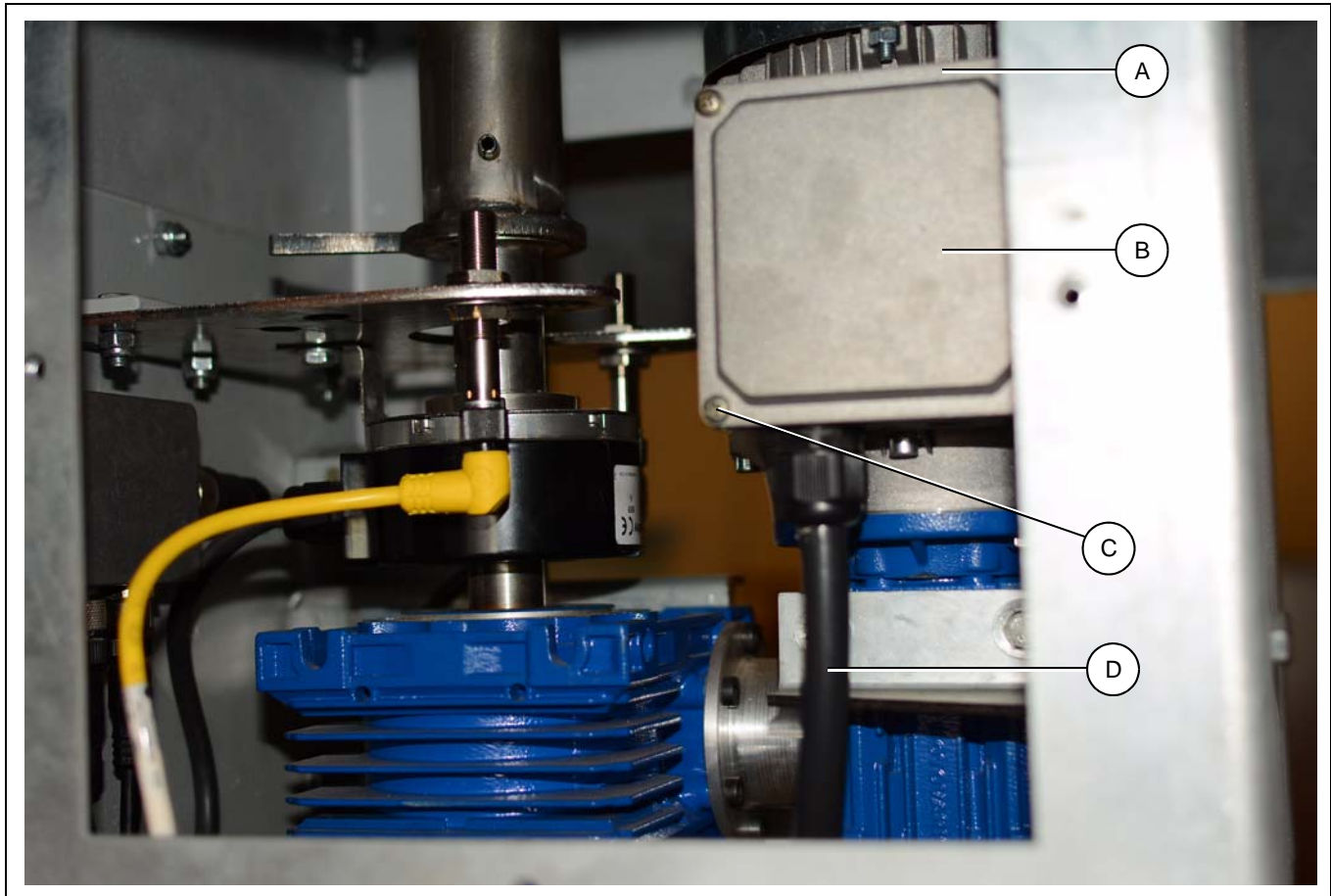

**Figure 3C** Cable fitting connection to motor junction box.

Ref #	Description
A	Motor Junction Box Cover
B	Motor Junction Box
C	Motor Junction Box Cover Screw
D	Motor Cable

## Electric Motor Wiring Diagram

The electric motor supplied with the GSI Electronic Distributor Control system is designed to be capable of running on either low or high voltage. The variable frequency drive (VFD) supplied with the system supplies 230V 3 phase power and requires that the electric motor be configured for **low voltage** operation. In order to ensure proper operation, verify the motor jumpers are configured in accordance with the wiring diagram shown for low voltage operation. (See Figure 3D.)

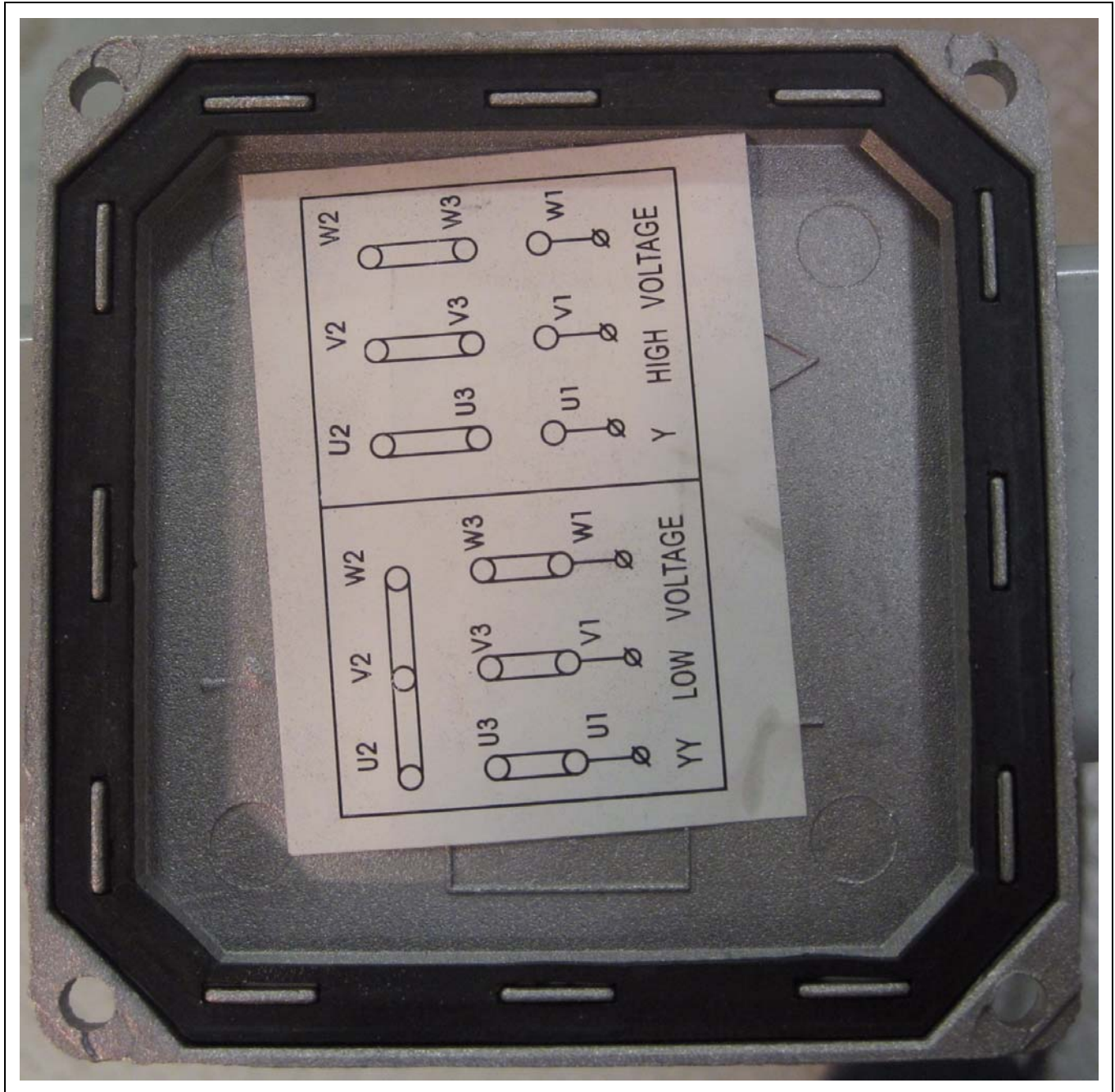
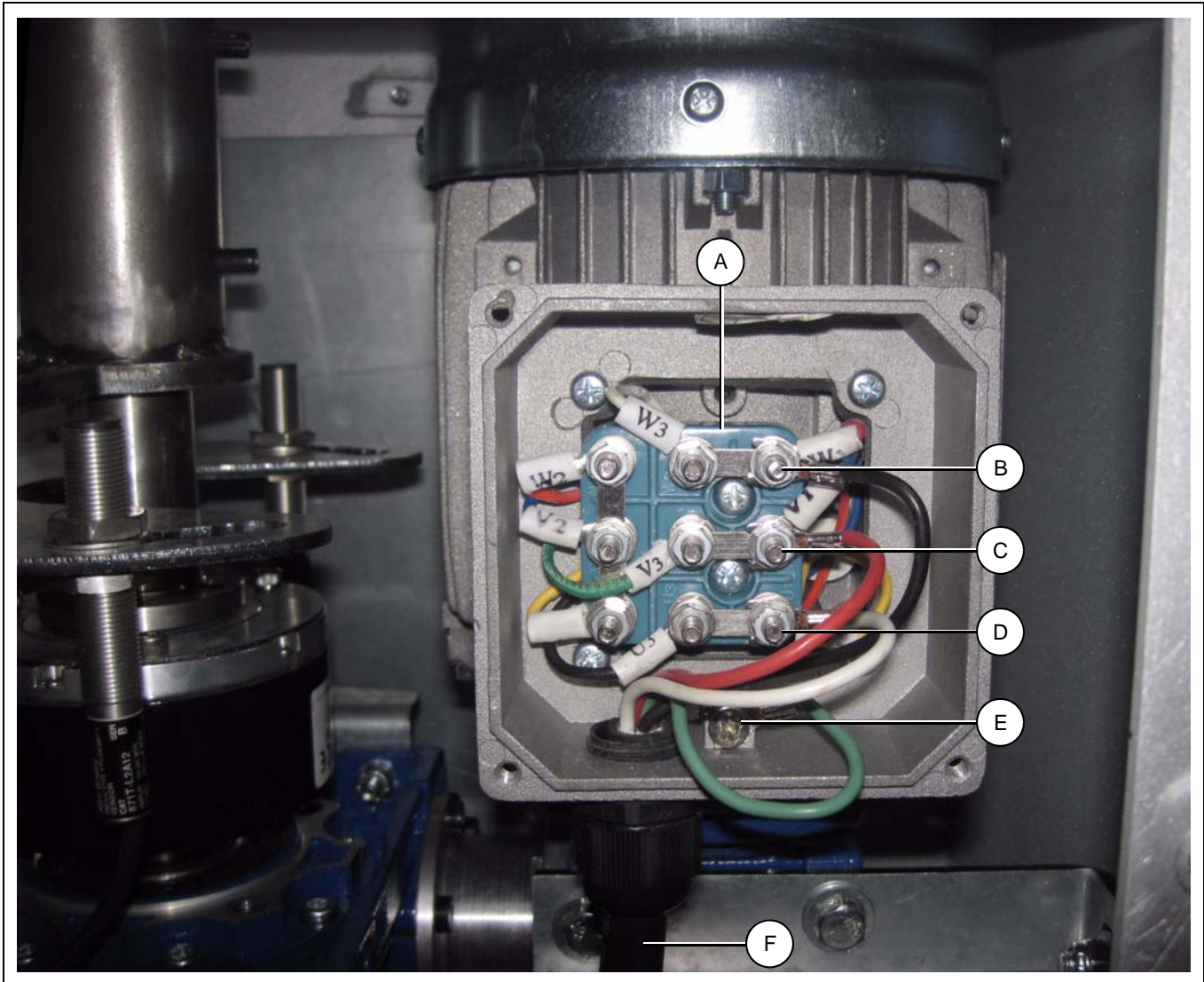

Figure 3D

## Motor Wiring Electrical Connections

Connect the motor wiring to the motor wiring terminals as shown in [Figure 3E](#). Re-install the motor junction box cover and screws before proceeding.

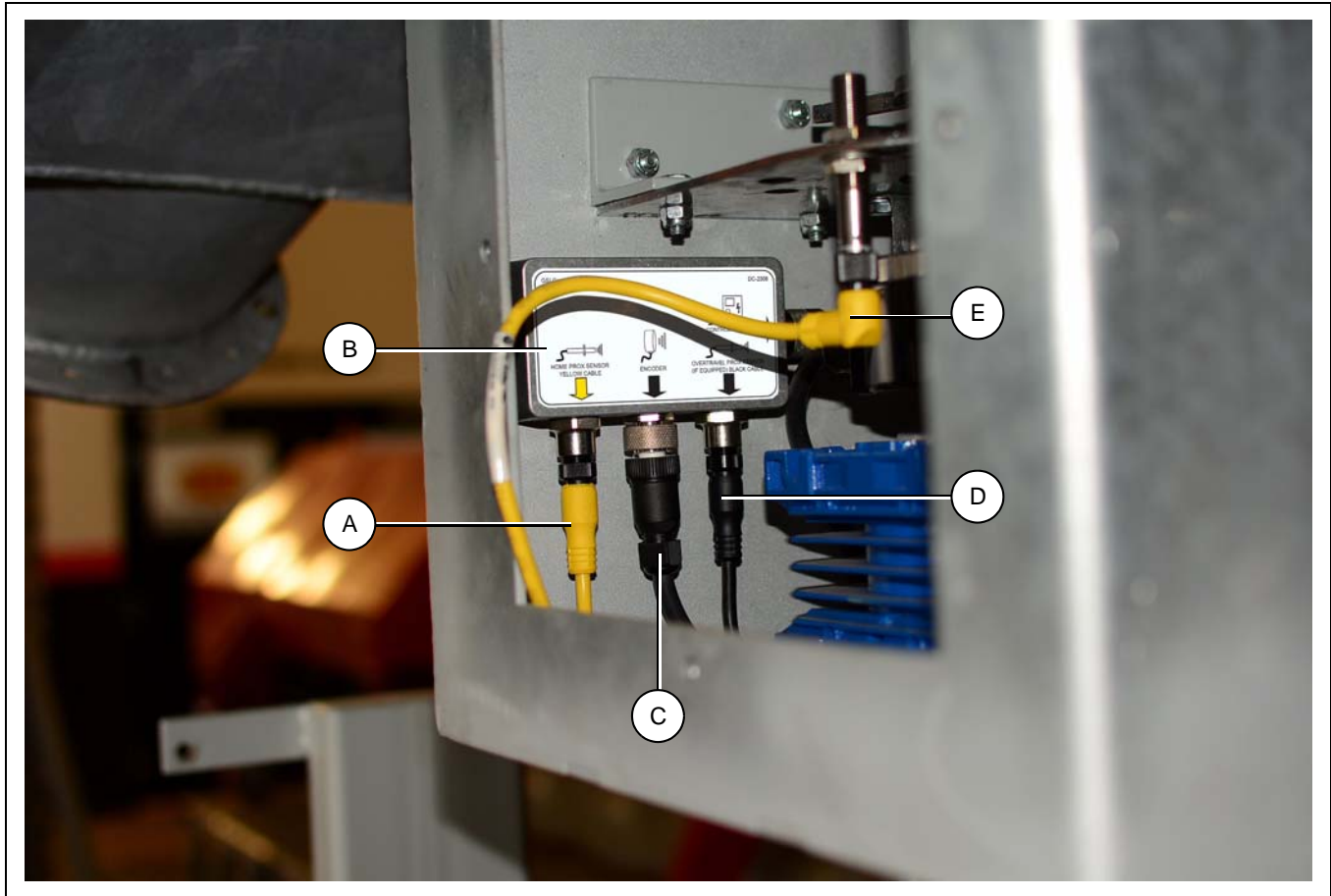

**Figure 3E** Motor Wiring to Motor Junction Box Electrical Connections

Ref #	Description
A	Motor Wiring Terminal Block
B	Wire W
C	Wire V
D	Wire U
E	Ground Wire
F	Motor Cable

## Sensor Wiring Connections to Connector Box

Pull sensor cable through conduit to enclosure. (See Figure 3F.)



**Figure 3F** Control Panel Wiring to Junction Box Electrical Connections

Ref #	Part #	Description
A	DEC0108	Home Proximity Sensor Cable
B	DEC0105	Connection Enclosure
C	DEC0106	Encoder
D	DEC0109	Over-Travel Proximity Sensor Cable
E	DEC0026-XXX	Sensor Cable

**NOTE:** "XXX" represent the length of the cable.

### 3. Electrical Installation

## Enclosure Covers Installation

Once all wiring is complete, install the two (2) side access covers (DEC0012) (A) using four (4) 1/4"-20 x 3/4" HHCS bolts (S-1429) (D) and 1/4" lock washer (S-2041) (C) each and install the bottom enclosure cover (DEC0013) (B) using ten (10) 1/4"-20 x 3/4" HHCS bolts (S-1429) (D) and 1/4" lock washers (S-2041) (C) as shown in [Figure 3G](#). Ensure that no wires are pinched or damaged when installing access covers.

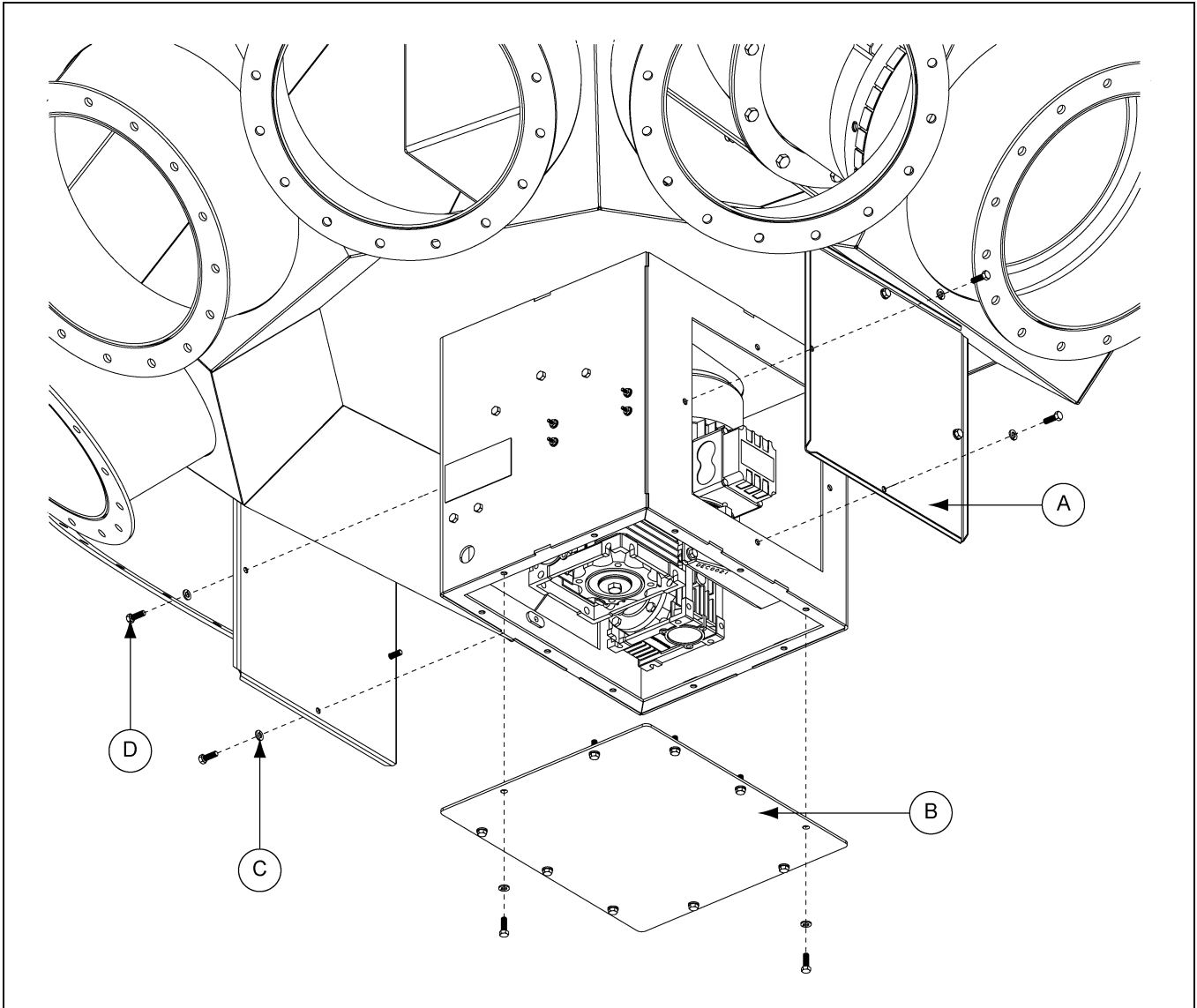

**Figure 3G** Enclosure Covers Installation

Ref #	Part #	Description
A	DEC0012	Side Access Cover
B	DEC0013	Bottom Enclosure Cover
C	S-2041	1/4" Lock Washer
D	S-1429	1/4"-20 x 3/4" HHCS Bolt

### Control Panel Installation Guidelines

The following requirements must be followed when installing and mounting the control panel:

All wiring should be performed by a licensed/qualified electrician in accordance with the National Electric Code (NEC), state codes and local codes.

Never mount the control panel immediately beside or above heat generating equipment or directly below water or steam pipes.

The atmosphere surrounding the control panel must be free of combustible vapors, chemical fumes and corrosive materials.

The control panel must be easily accessible for maintenance and operation.

Mount the control panel on a flat, vertical surface using 1/4" fasteners.

Ensure that the mounting surface is sufficient to support the weight of the control panel.

Rigid conduit connections must be placed either at sides or bottom of the control panel.

### 3. Electrical Installation

## Electric Motor Connections at Control Panel

Connect the motor wiring to the terminals on the Variable Frequency Drive (VFD) in the control panel as shown in [Figure 3H](#). Please note that the U-V-W order of the wires is not configured as labeled on the VFD. Motor wiring should be kept as far away from sensor wiring terminal blocks as the installation configuration permits.

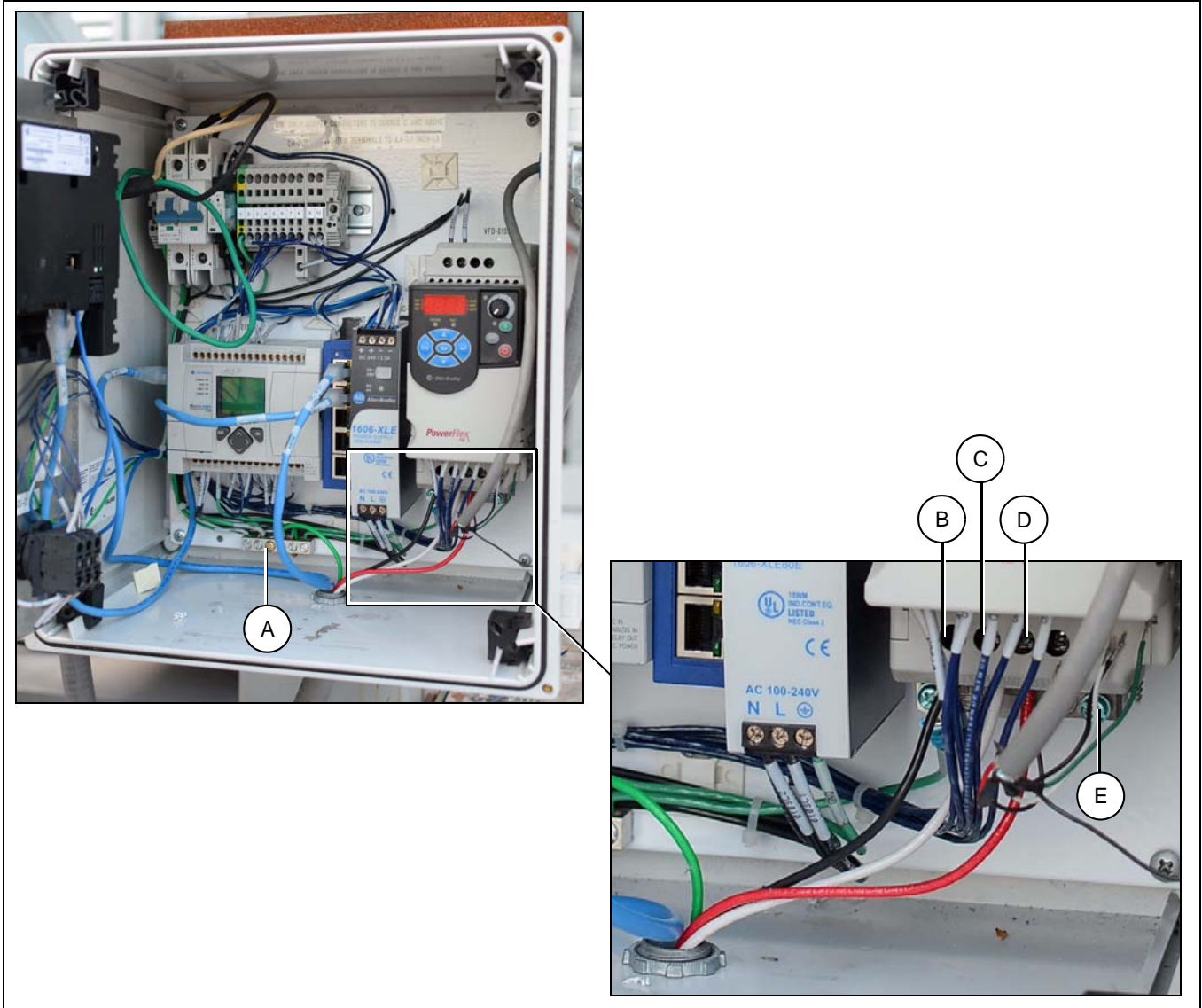

**Figure 3H** Control Panel Wiring from Motor Electrical Connections

Ref #	Description
A	Ground Terminal Block
B	Wire U
C	Wire W
D	Wire V
E	Ground Wire



## Sensor Terminations in Control Panel

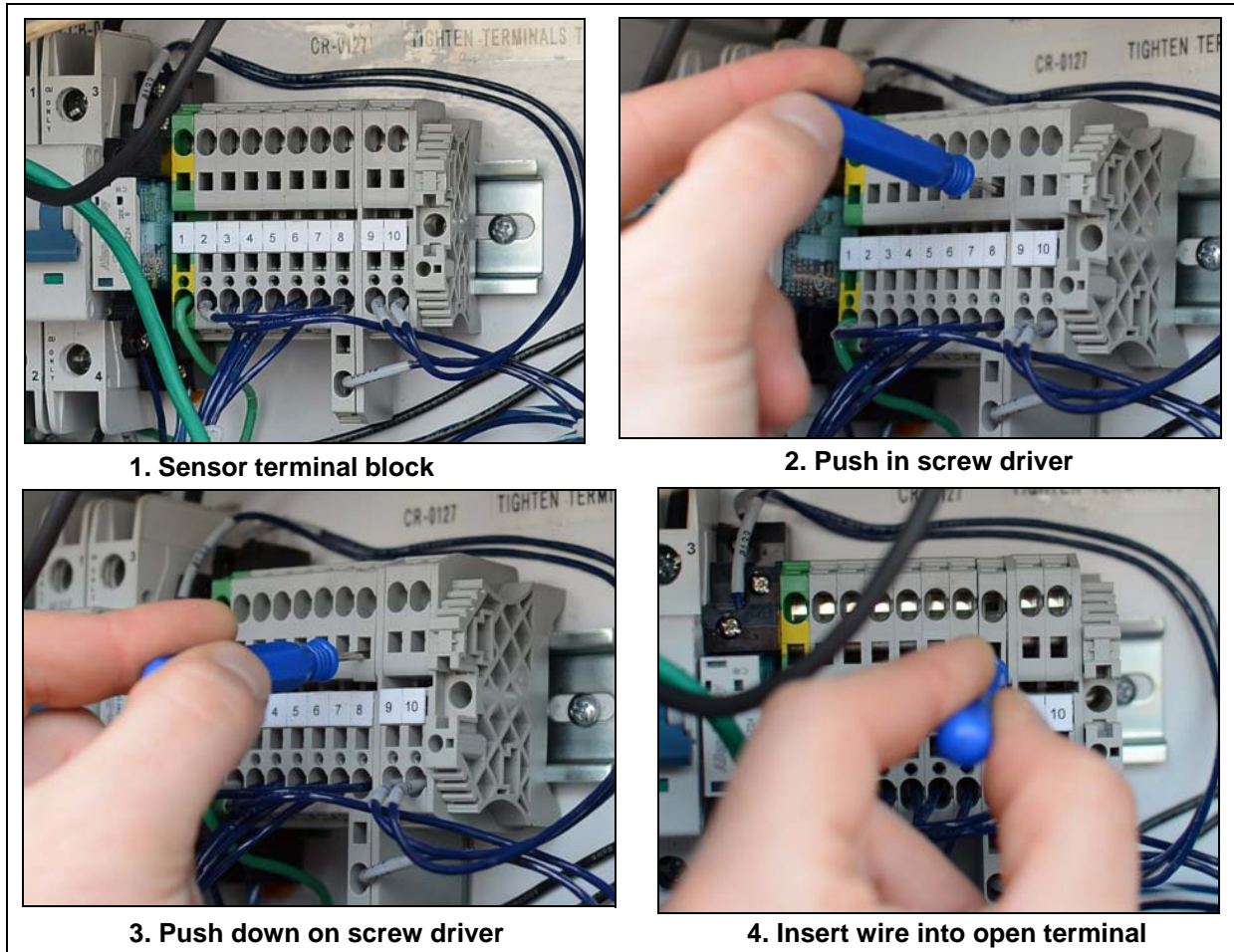

Figure 3I

Placing a wire into the terminal block.

**NOTE:** *Insulation must be removed from the end of the wire for a good connection.*

1. Insert a small screw driver into the square opening under the terminal.
2. Push down on the small screw driver.
3. Insert the wire into the open terminal block above the small screw driver.
4. Remove the small screw driver to secure the wire.
5. Repeat for remaining wires. (*See Figure 3I.*)

### Wire Connections for Terminal Block

Terminal Block #	Wire Connection
1	Shield
2	Black
3	White
4	Red
5	Green
6	Orange
7	Blue
8-11	Used for Safety Interlocks

**NOTE:** #11 Not shown here.

### 3. Electrical Installation

## Power Supply Wiring to Control Panel Electrical Connections

**NOTE:** Ensure the power supply voltage source is OFF before installation.

Install power supply cable through the control panel using suitable hardware as shown in [Figure 3J](#).

Connect the power supply hot wires (B) to the control panel circuit breakers (C) as shown in [Figure 3J](#).

Connect the power supply ground wire (D) as shown in [Figure 3J](#) to the ground terminal block as shown in [Figure 3H on Page 16](#).

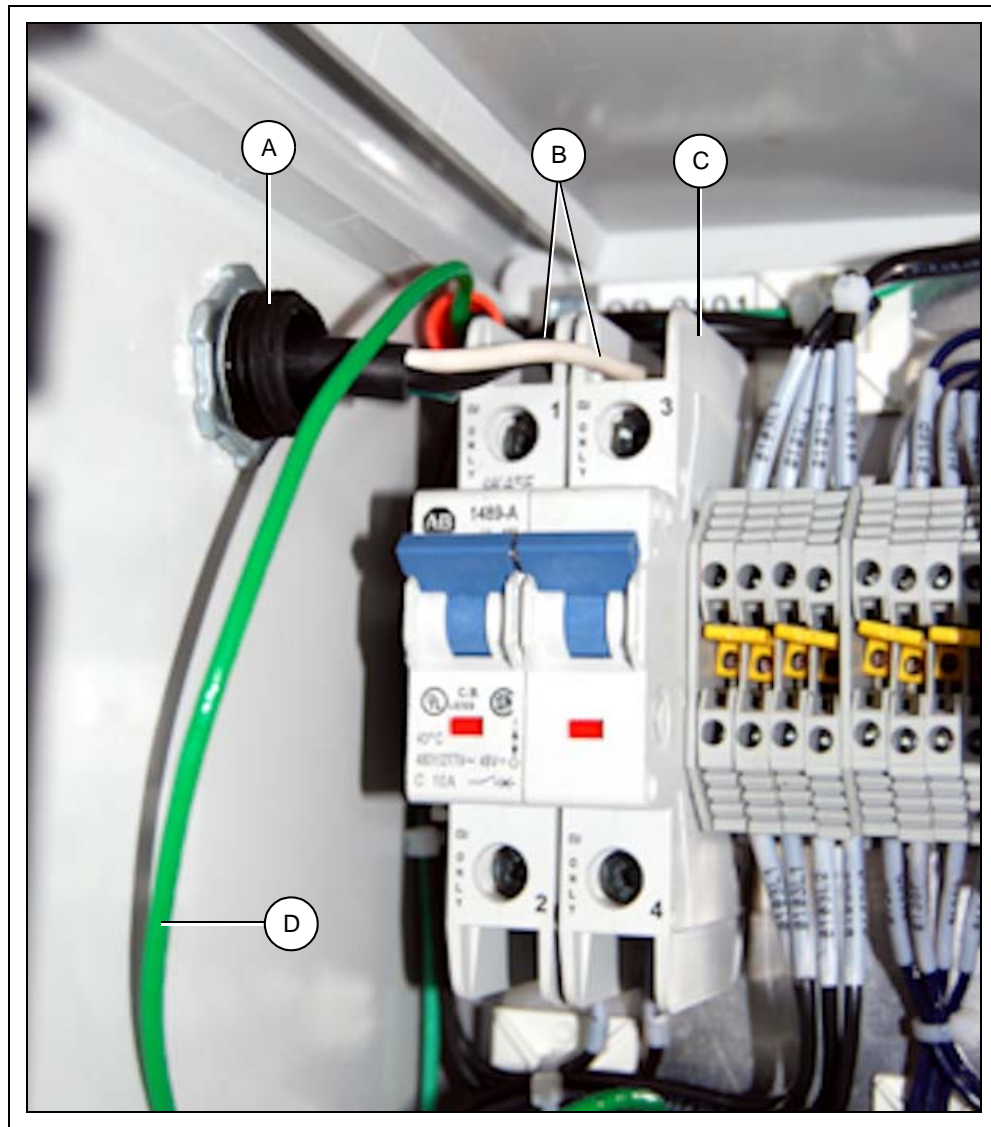

**Figure 3J** Control Panel Wiring from Motor Electrical Connections

Ref #	Description
A	Power Cable Hardware
B	Hot Wires
C	Control Panel Circuit Breakers
D	Power Supply Ground Wire

## Initializing Screen

When powering up the distributor the first screen that appears is the “Initializing” screen. (See Figure 4A.) During a first time start-up, press the “Diagnostic Screen” button to proceed to the diagnostic screen in order to complete start-up checklist. If the start-up checklist has already been completed, press OK to initialize system. Distributor will move to “HOME POSITION” to verify positioning, then display the MAIN screen.



Figure 4A Initial Start-Up Screen

## 4. Operation Procedures

### Start-Up Checklist

Press “Diagnostic Screen” button to enter diagnostic menu to complete the following checklist:

Check	Procedure
Motor Direction	Insert key into key switch override on front of control panel. Rotate switch to forward “FWD” position for 4 seconds. Verify that “DIRECTION” in bottom right hand corner reads “FORWARD” during this. If “REVERSE” is displayed after 4 seconds, reverse any two (2) motor leads on motor or VFD to correct rotation direction.
Encoder Function	Using key switch, rotate switch to reverse “REV” position for 4 seconds. Verify that inputs 0 and 1. (Labeled ENCODER CHANNEL A and ENCODER CHANNEL B in top left hand corner of screen.) Toggle ON and OFF while switch is held in reverse position. If either channel fails to toggle ON or OFF, verify that encoder is wired correctly.
Home Prox Test	Using a second person as a spotter, use key switch to rotate spout in reverse direction until the “flag” welded to the drive shaft is positioned over the top of the “home” proximity switch. (Located on side of sensor mounting plate labeled “RED”.) Verify that when flag is positioned above proximity switch, input 2 labeled “HOME PROX SWITCH” turns green and shows “ON” on diagnostic screen. If input does not show “ON”, check that gap between switch and flag is $0.050" \pm 0.010"$ .
Overtravel Test	Using a second person as a spotter, use key switch to rotate spout in forward direction until the “flag” welded to the drive shaft is positioned over the top of the “overtravel” proximity switch. (Located on side of sensor mounting plate labeled “GREY”.) Verify that when flag is positioned above proximity switch, input 2 labeled “OVERTRAVEL PROX” turns green and shows “ON” on diagnostic screen. If input does not show “ON”, check that gap between switch and flag is $0.050" \pm 0.010"$ .

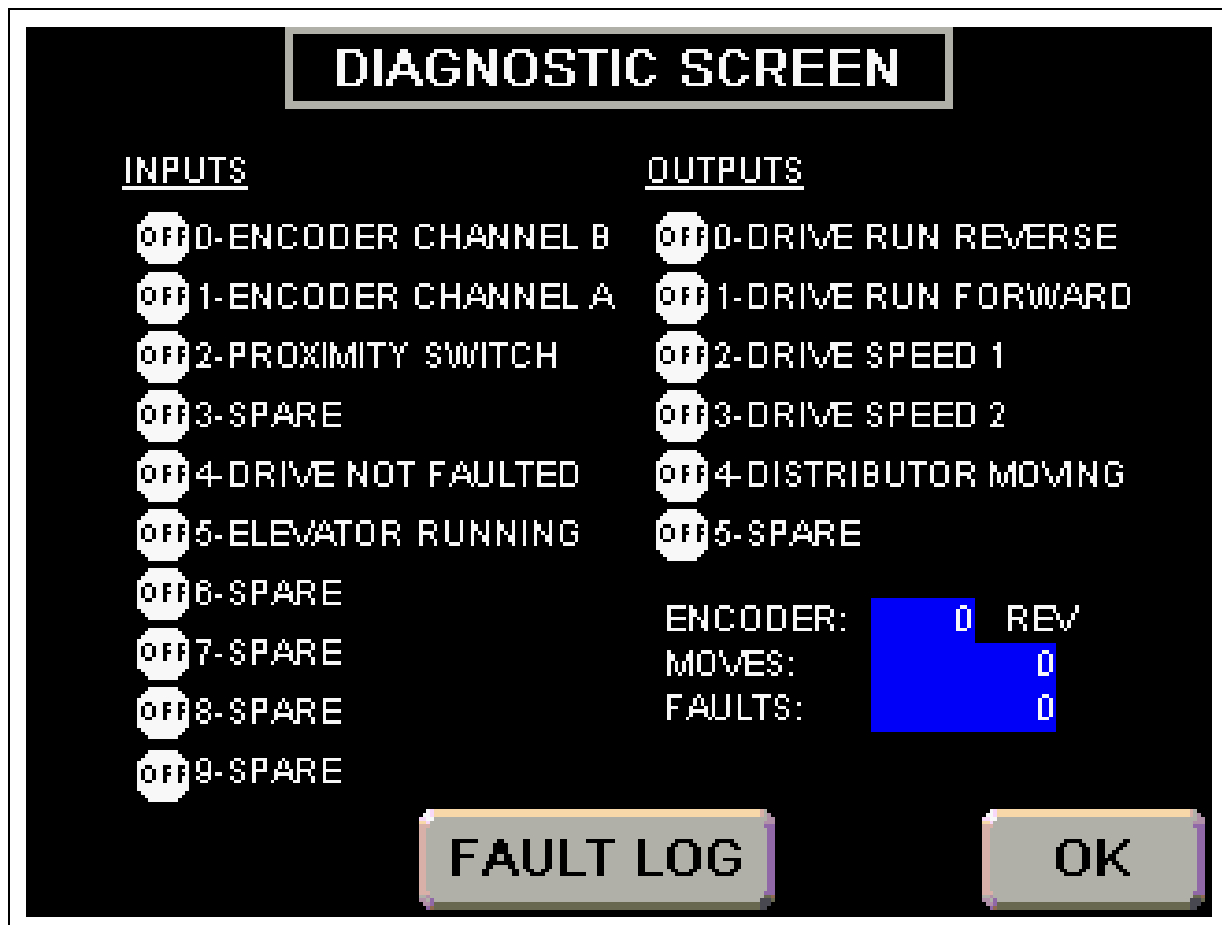

Figure 4B Diagnostic Screen

## Main Screen

Depending on the number of spouts in the current configuration, one of the following screens will be displayed. (See [Figure 4C](#), [Figure 4D](#), [Figure 4E](#) and [Figure 4F](#).) The display depicts a view of your distributor as it would appear if looking down from above, with lower spout numbers to the left and higher spout numbers to the right. The name of the current spout is indicated at the top of the screen and is indicated in the graphic with a green circle. At the bottom of the screen are three (3) buttons to navigate to either the Help Menu, Move Position Screen or Setup Menu.

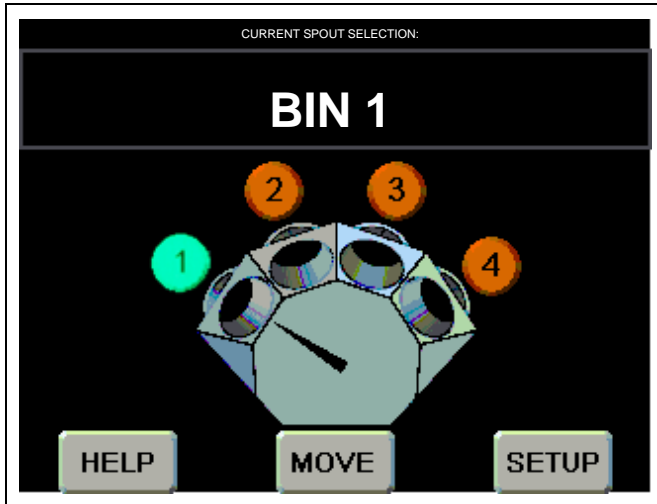

Figure 4C Four (4) Spout Main Screen

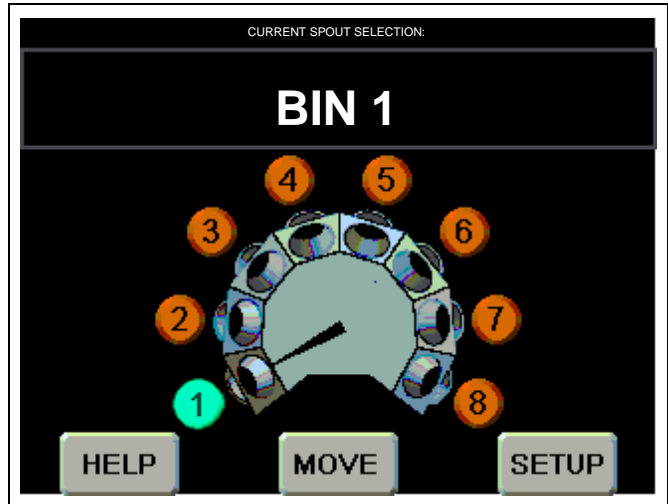

Figure 4E Eight (8) Spout Main Screen

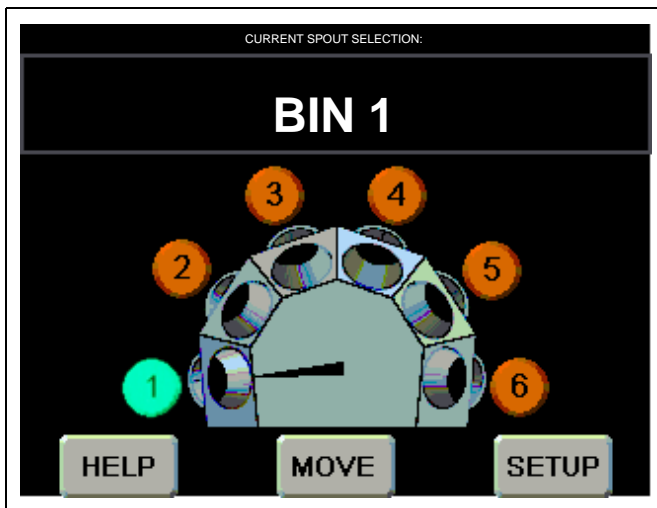

Figure 4D Six (6) Spout Main Screen

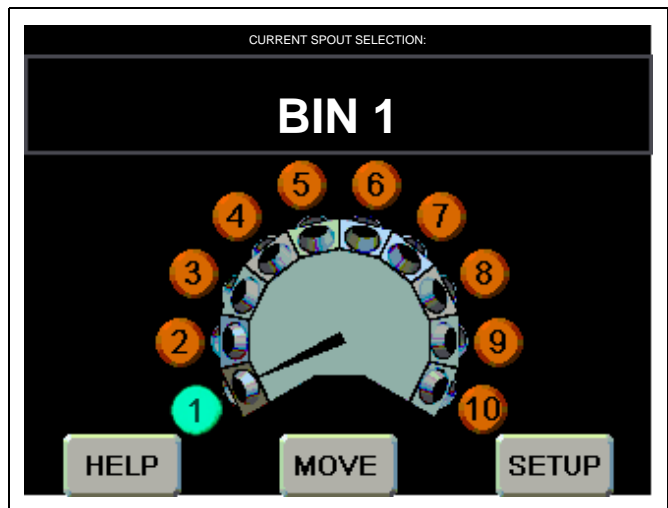

Figure 4F Ten (10) Spout Main Screen

## 4. Operation Procedures

### Move Position Screen

This screen allows the user to change the distributor's current spout position. The green highlighted spout number indicates the current selection. A spout number with a red circle with a line through it indicates a position that is currently locked-out. (See "Position Lock-Out Screen" [on Page 29.](#)) (See [Figure 4G.](#))

**NOTE:** *The default names for each spout will be "BIN #", see "Position Names Screen" [on Page 25](#) for instructions for customizing the spout names.*



Figure 4G Move Position Screen

### Moving Spout Position

1. On the "Move Position" screen, select the position you want the spout to move to by pressing the button displaying the desired spout name on the screen.
2. The "Main Menu" screen will now display a flashing message "Moving to" at the top of the screen, the selected spout number will flash yellow while the pointer is moving to the selected spout. The destination spout number will turn green when the move is complete.

### Verifying Spout Alignment

**NOTE:** *In the following steps, the distributor must be in a position to view the spout location in the distributor to verify that it lines up correctly. If the distributor is installed above ground level, two (2) people will be needed; one to verify the alignment of the distributor spout and one to operate the controller.*

1. From the "Main" screen or the "Setup Menu", select "MOVE" to view the "Move Position" screen. ([See Figure 4G.](#))
2. On the "Move Position" screen, select the position you want the spout to move to by pressing the spout name on the screen.
3. The "Main Menu" screen will now display a flashing message "Moving to" at the top of the screen, the selected spout number will flash yellow while the pointer is moving to the selected spout. The destination spout number will turn green when the move is complete.
4. Once the spout has finished moving, visually check and verify the spout is centered with the distributor discharge spout. If alignment requires adjustment, see "Position Locations Screen" [on Page 27](#) to adjust the positioning.
5. Repeat procedure for all other spouts.

## Setup Menu Screen



Figure 4H Setup Menu Screen

**Configuration Setup:** Displays the machine setup screen that allows the user to change the distributor's parameters or reload default values. See "Configuration Setup Screen" [on Page 24](#).

**Position Names:** Allows the user to assign or change the name of each spout position and to create or change a name for the distributor. See "Position Names Screen" [on Page 25](#).

**Position Locations:** Displays the positioning screen which allows the user to set the value that aligns the spouts with the distributor. See "Position Locations Screen" [on Page 27](#).

**Position Lock-Out:** Allows the user to lock or unlock spouts from being used. See "Position Lock-Out Screen" [on Page 29](#).

**Homing Interval:** Allows the user to set the number of times before the "Perform Homing Now" warning appears. See "Homing Interval Screen" [on Page 30](#).

**Perform Homing Now:** Press this to perform the homing operation to re-calibrate the distributor.

## 4. Operation Procedures

### Configuration Setup Screen

This screen allows the user to change the distributor's spout diameter property, total of number of spouts and for resetting the distributor back to the default settings. (See Figure 4I.)

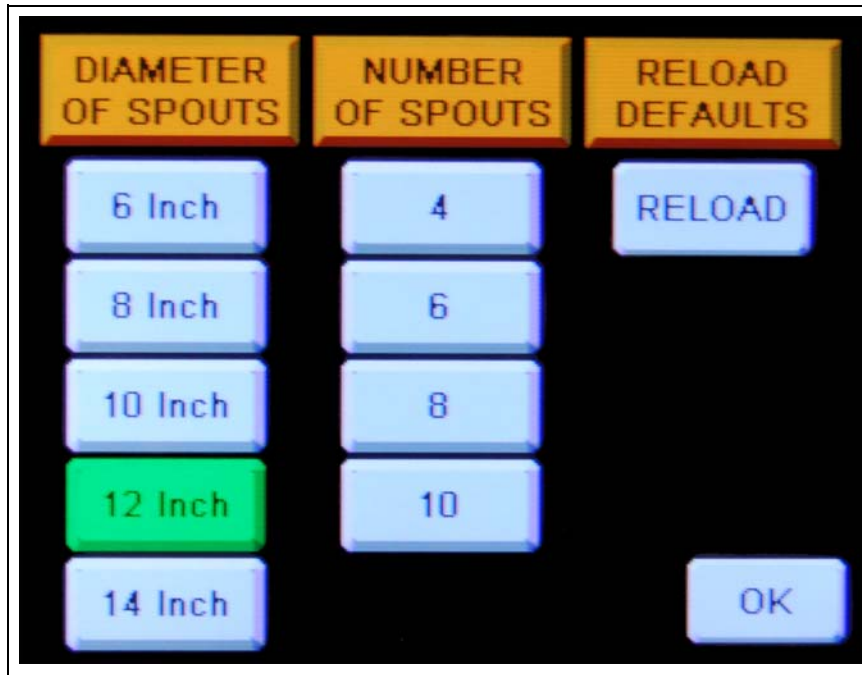

Figure 4I Configuration Setup Screen

**Diameter of Spouts:** Press the button that matches the size of the spout that is currently installed on the distributor. The diameter that is selected will turn green and the number of spouts available for that diameter will be displayed.

**Number of Spouts:** Press the button that matches the current configuration of the distributor. The number that is selected will turn green. The number of spout options will change according to the diameter of spout selected.

**Reload Defaults:** If during operation, any configuration parameters are altered from the original settings, pressing this button will revert settings to the default values.

**OK:** Press this button to save the current configuration and be brought back to the Setup Menu.

**NOTE:** A warning message will appear if distributor has already been previously configured. (See Figure 4J.)

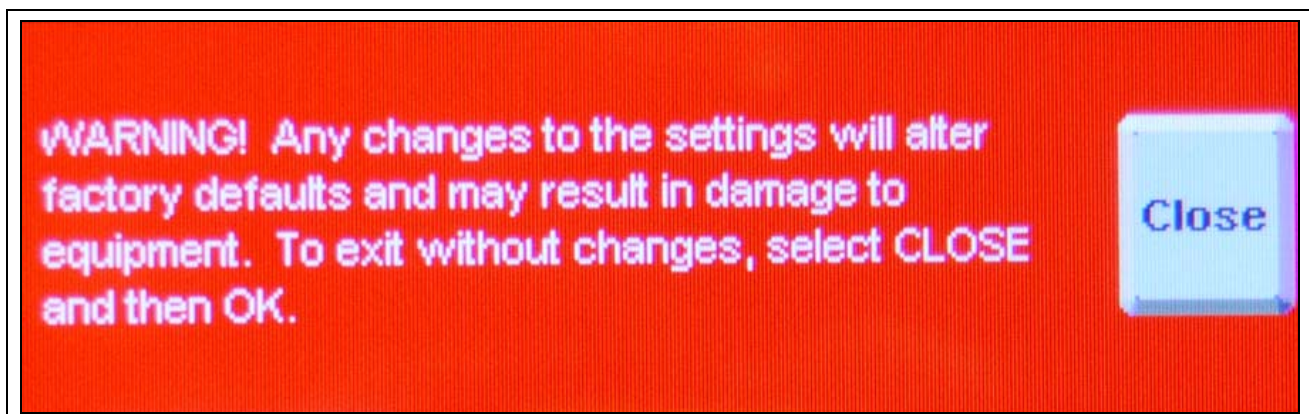

Figure 4J



## Position Names Screen

This screen allows the user to individually name each of the distributor discharge spouts and is also used to create or modify a distributor name. (See Figure 4K.)

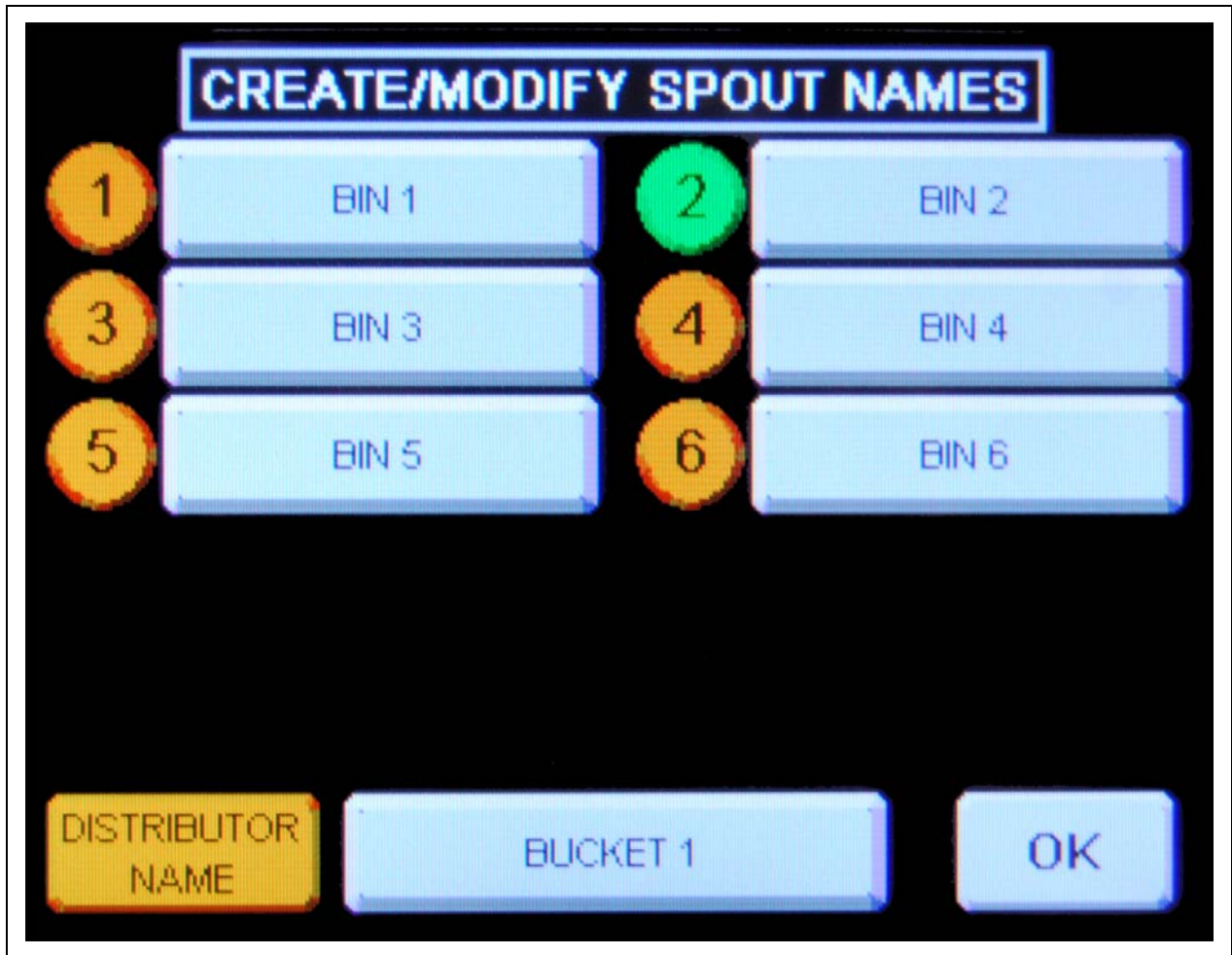

Figure 4K Create/Modify Spout Names

## 4. Operation Procedures

### Create/Modify Spout Name

1. From the "Setup Menu", select "Position Names" to bring up the "Create/Modify Spout Names" screen.
2. Press the spout name to be modified to display an alphanumeric keypad. (See Figure 4L.)



Figure 4L Alphanumeric Keypad

3. Type in the desired name for the spout position and press "enter".
4. Select "OK" to return to "Setup Menu".

### Create/Modify Distributor Name

1. From the "Setup Menu", select "Position Names" to bring up the "Create/Modify Spout Names" screen.
2. Next to ochre "Distributor Name" label, press the distributor name to display an alphanumeric keypad. (See Figure 4L.)
3. Type in the desired name for the spout position and press "enter".
4. Select "OK" to return to "Setup Menu".

## Position Locations Screen

This screen allows the user to adjust the spout positioning so it lines up with the center of the distributor discharge. Adjustments can be made individually or an offset can be used to adjust all spouts by the same amount. (See Figure 4M.)

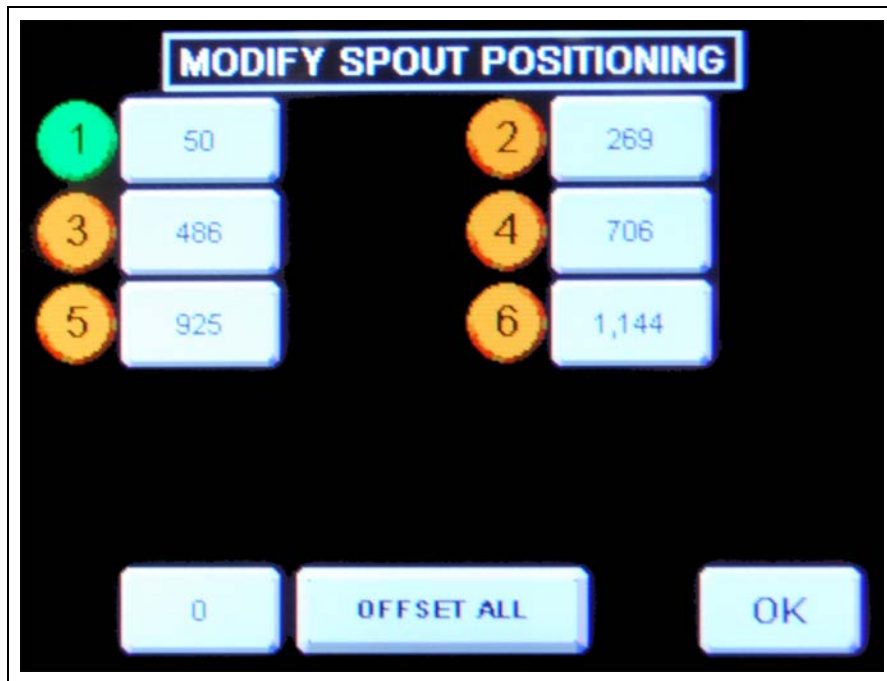

Figure 4M Modify Spout Positioning

## Modify Spout Positioning

1. From the "Setup Menu", select "Position Locations" to bring up the "Modify Spout Positioning" screen.
2. In the "Modify Spout Positioning" screen select the spout that requires adjustment by touching the value pad next to the spout number balloon. A number keypad will display. (See Figure 4N.)

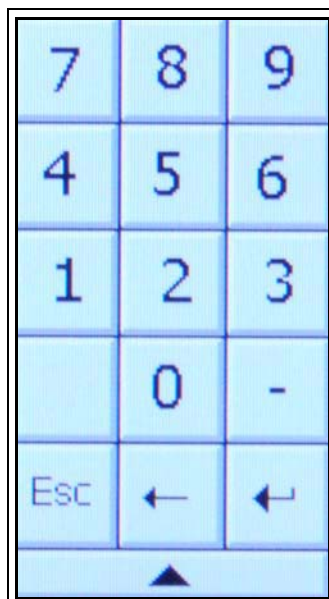

Figure 4N Number Keypad

## 4. Operation Procedures

3. Insert the desired value and press “enter”. ←

**NOTE:** Entering a value larger than the existing value will move spout position to the left, entering a smaller value will move the position to the right.

4. Select “OK” to return to “Setup Menu”.

5. Verify spout alignment with distributor. See “Verifying Spout Alignment” [on Page 22](#).

### Offset All

1. From the “Setup Menu”, select “Position Locations” to bring up the “Modify Spout Positioning” screen.

2. In “Modify Spout Positioning” screen select the “0” key pad next to “OFFSET ALL”. A number keypad will display. (See [Figure 40](#).)

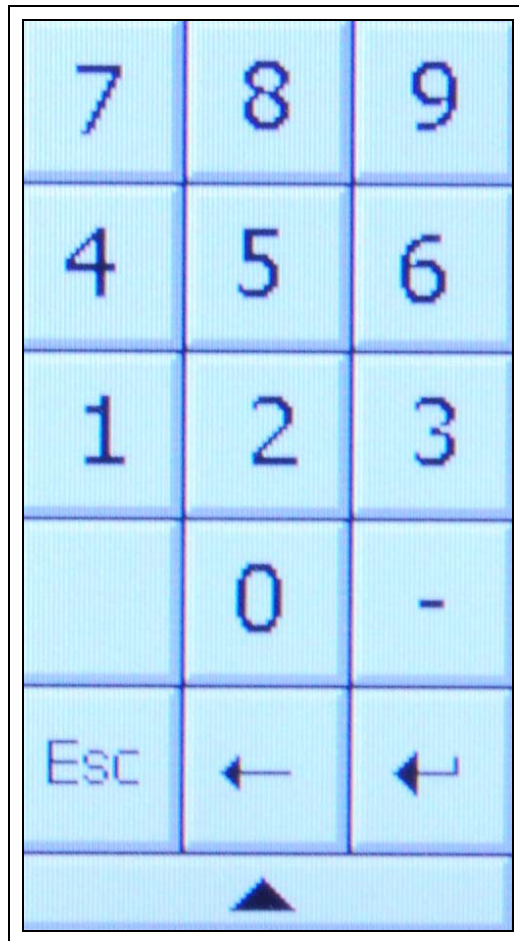

Figure 40 Help Menu Screen

3. Insert the desired value and press “enter”. ←

To offset the spouts to the left, use a positive value and to offset to the right, use a negative value.

**NOTE:** A maximum offset at any one time is  $\pm 20$ .

4. Select “OK” to return to “Setup Menu”.

5. Verify each spout alignment with distributor. See “Verifying Spout Alignment” [on Page 22](#).

## Position Lock-Out Screen

The position lock-out allows you to lock-out a distributor discharge spout position so it can not be used until it is manually unlocked. (See [Figure 4P.](#))

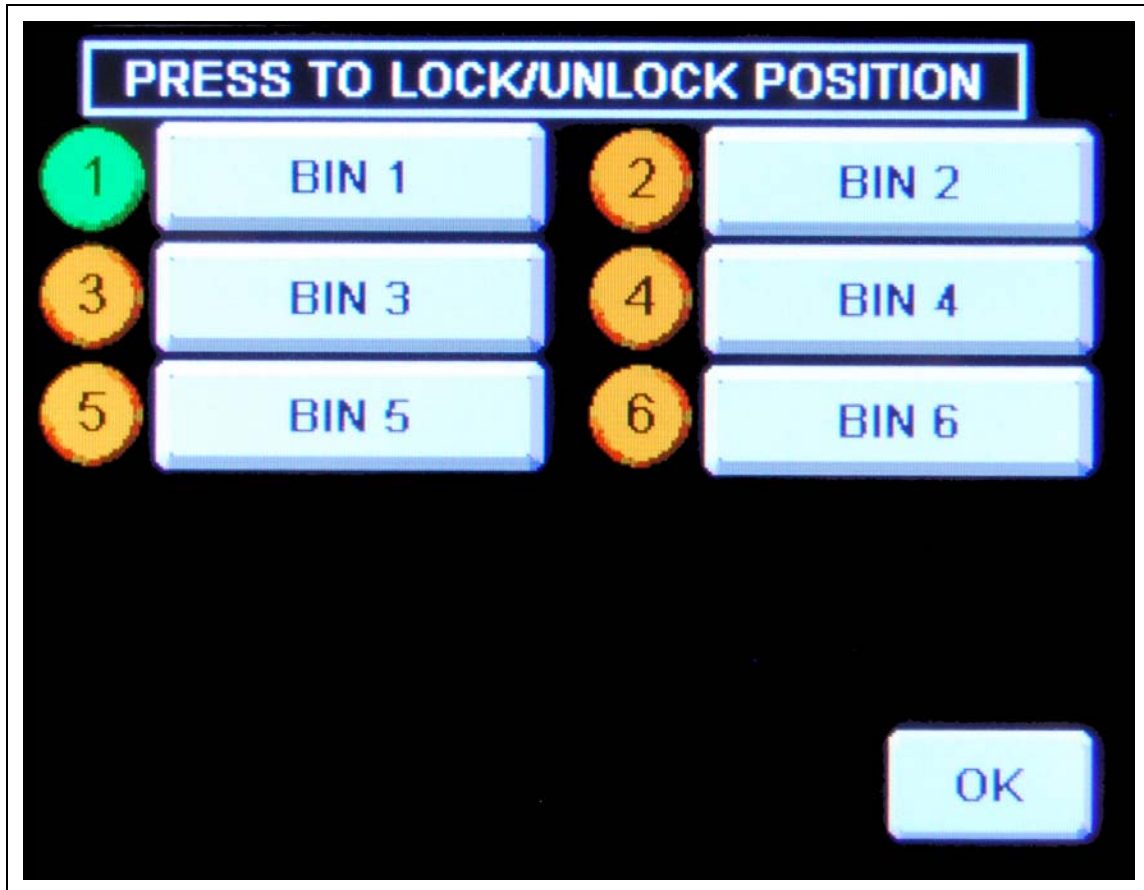

Figure 4P Lock/Unlock Position

### Lock/Unlock Position

1. From the “Setup Menu”, select “Position Lock-Out” to display the “Lock/Unlock Position” setup screen.
2. Press name of spout to toggle between locked and unlocked. When in the locked position the number balloon will change to a red circle with a line through it.

**NOTE:** *The position that the distributor is currently located, indicated by a green number balloon icon, can not be locked out. Move the spout position to a different location then try again. See “Move Position Screen” on [Page 22](#).*

3. Select “OK” to apply changes and return to “Main Menu”.

## 4. Operation Procedures

### Homing Interval Screen

The homing interval screen allows the user to set the number of times the distributor position may be moved before a warning displays for home position re-calibration. A default value of 50 is standard. (See Figure 4Q.)

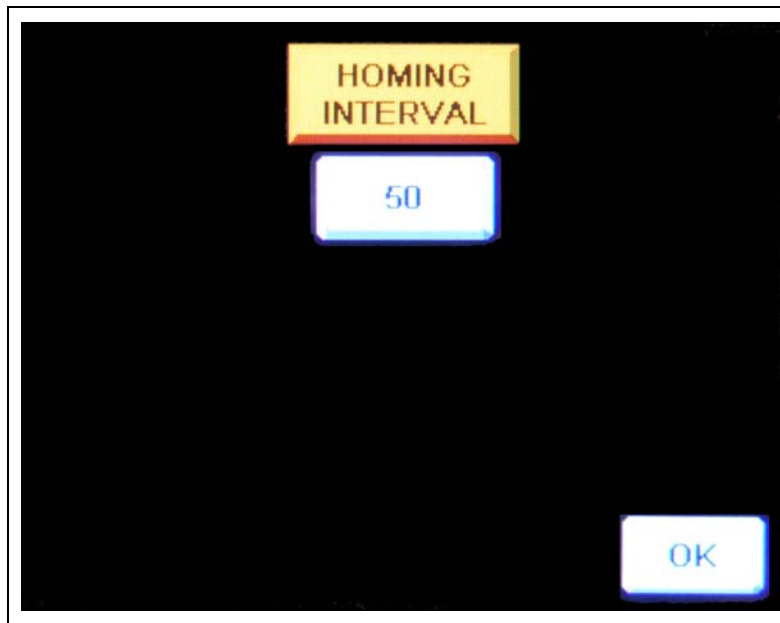

Figure 4Q Homing Interval Screen

### Setting Homing Interval

1. To access the homing interval from the “Setup Menu”, select “Homing Interval” to display the “Homing Interval” setup screen.
2. Press the button under the “Homing Interval” label. A number keypad will display. (See Figure 4R.)

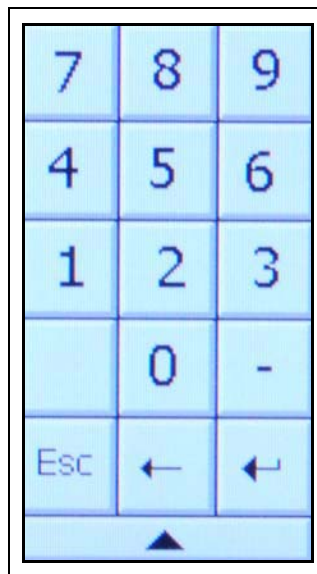



Figure 4R

3. Insert the desired value and press “enter”. 
4. Select “OK” to apply changes and return to “Main Menu”.

## Homing Warning

To help ensure accurate positioning of the distributor a homing warning will display when the number of times the distributor is re-positioned is equal to the homing interval. This message will occur every time that a spout move is attempted until the homing procedure is completed. The user will be given two (2) options: “Home Now” and “Home Next Move”. (See Figure 4S.)

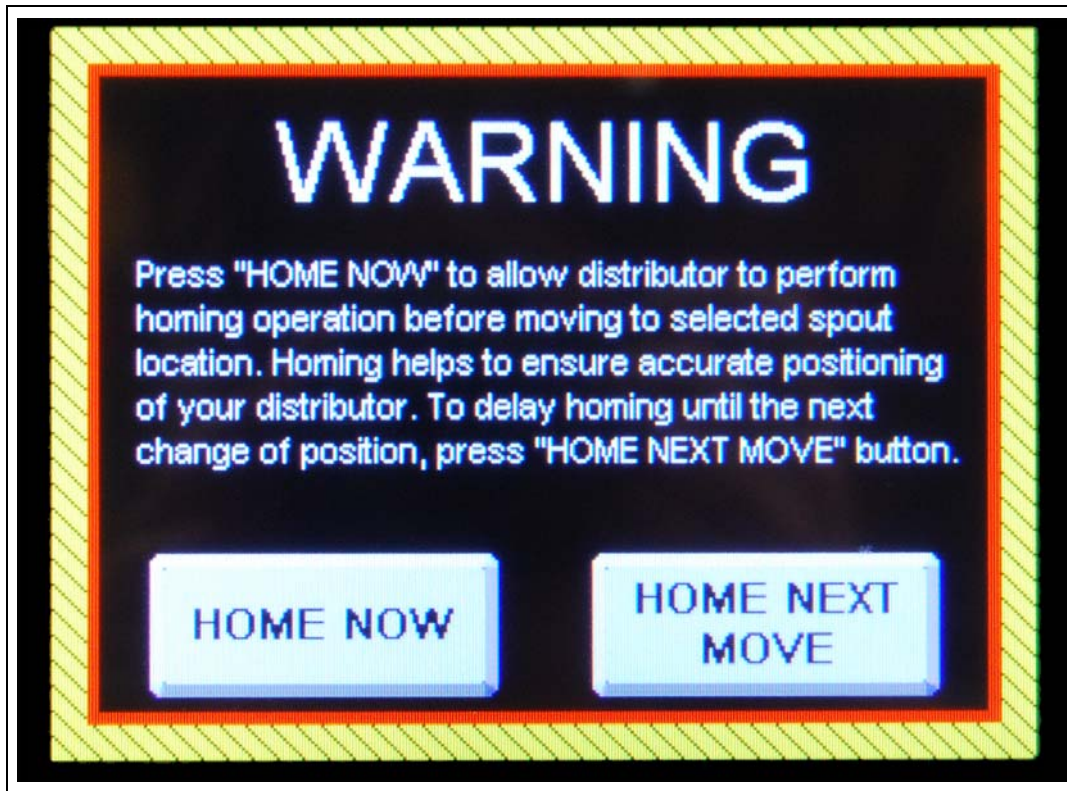

Figure 4S Homing Warning

### Home Now

Select to perform the homing calibration immediately. The user interface will return to the “MAIN” screen and “Homing” will be shown in yellow. After homing is complete, the spout will return to the selected position.

### Home Next Move

Select “Home Next Move” to skip the homing operation and move to the selected position. The user interface will continue to prompt you to home the unit during every subsequent move until homing is performed.

### Help Menu Screen

The help menu has six (6) options for displaying troubleshooting information for different faults that may appear during the operation of the distributor and for checking diagnostic parameters. (See Figure 4T.)

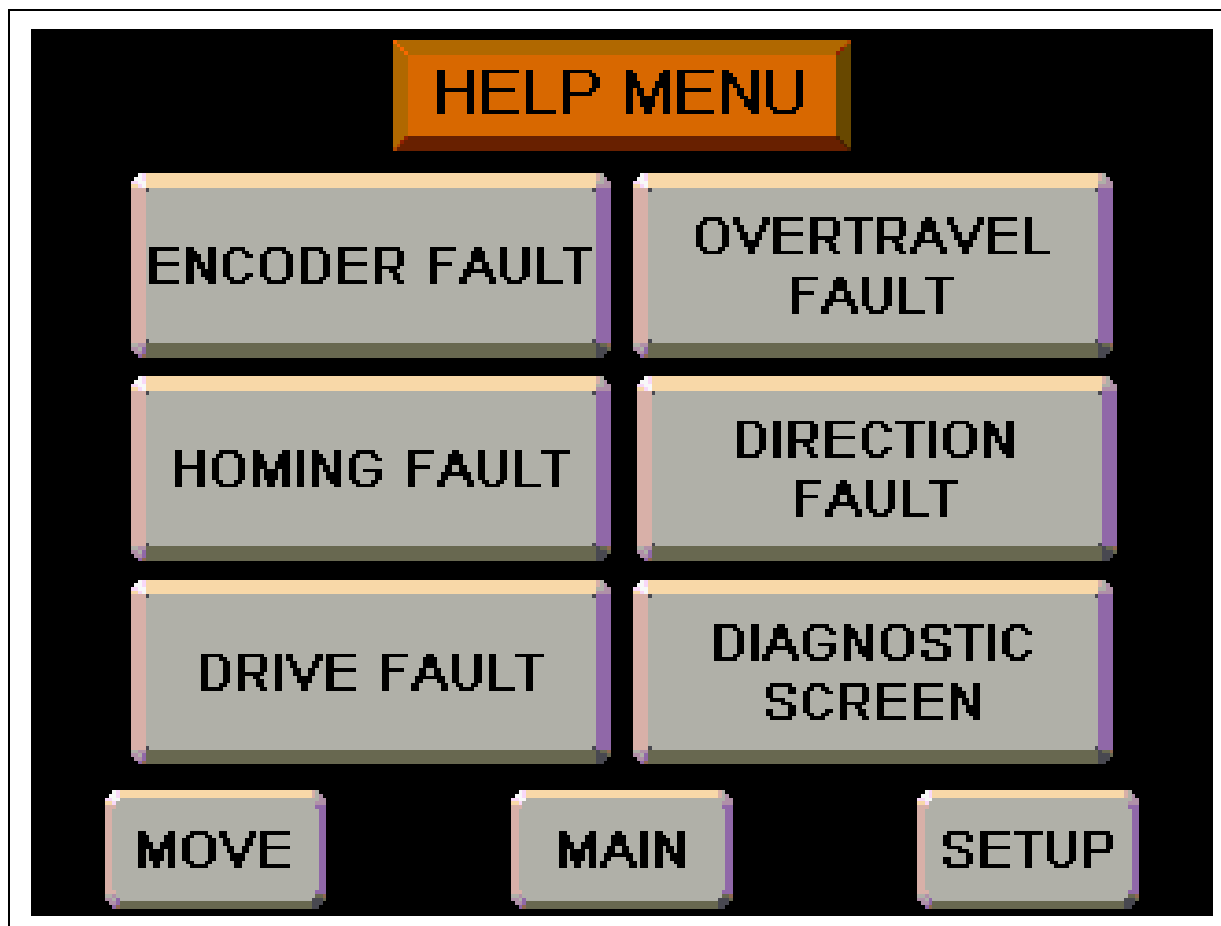

Figure 4T Help Menu Screen

**Encoder Fault:** Displays the “Encoder Fault” screen which displays fault codes and solutions for faults related to the function of the encoder during movement. (See Figure 4U on Page 33.)

**Drive Fault:** Displays the “VFD” Fault screen which offers possible causes and solutions to faults caused by the variable frequency drive. (See Figure 4V on Page 33.)

**Homing Fault:** Displays the “Homing Fault” screen which offers possible causes and solutions to faults caused by a timeout of the homing procedure. (See Figure 4W on Page 34.)

**Overtravel Fault:** Displays the “Overtravel Fault” screen which offers possible causes and solutions to faults caused by the an overtravel condition. (See Figure 4X on Page 34.)

**Direction Fault:** Displays the “Direction Fault” screen which offers possible causes and solutions to faults caused by the detection of a rotation direction conflict. (See Figure 4Y on Page 35.)

**Diagnostic Screen:** Displays the status of the inputs and outputs of the Programmable Logic Controller (PLC) as well as the current encoder position count and rotation direction. (See Figure 4Z on Page 35.)



## Encoder Fault Screen

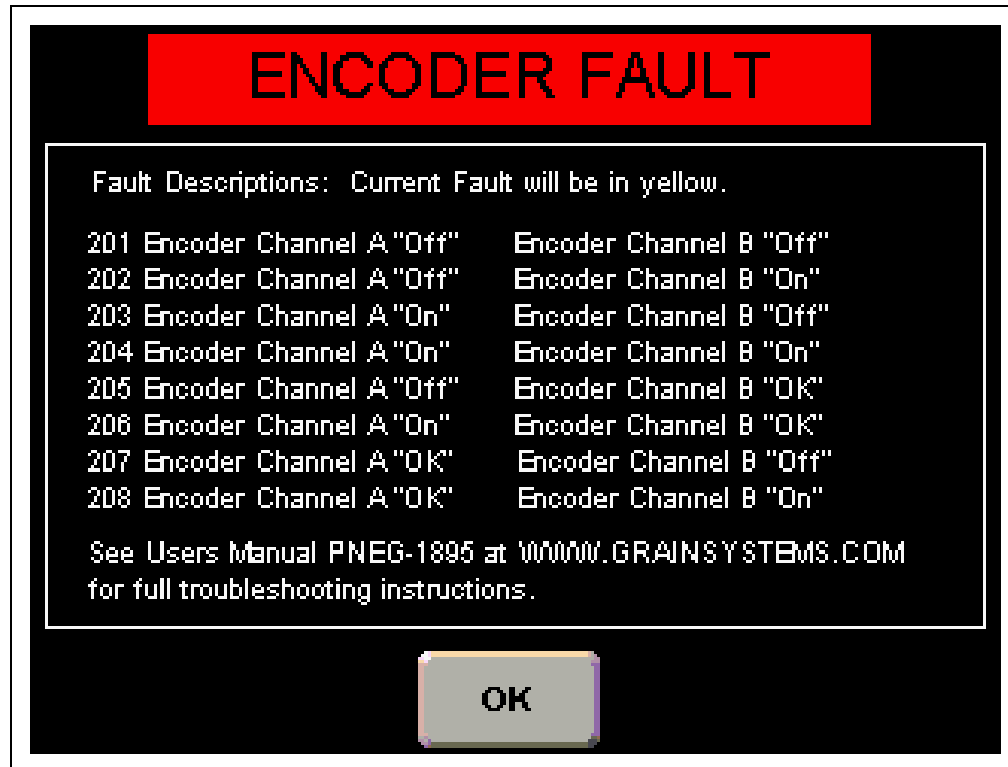

Figure 4U Encoder Fault Screen

## Drive Fault Screen

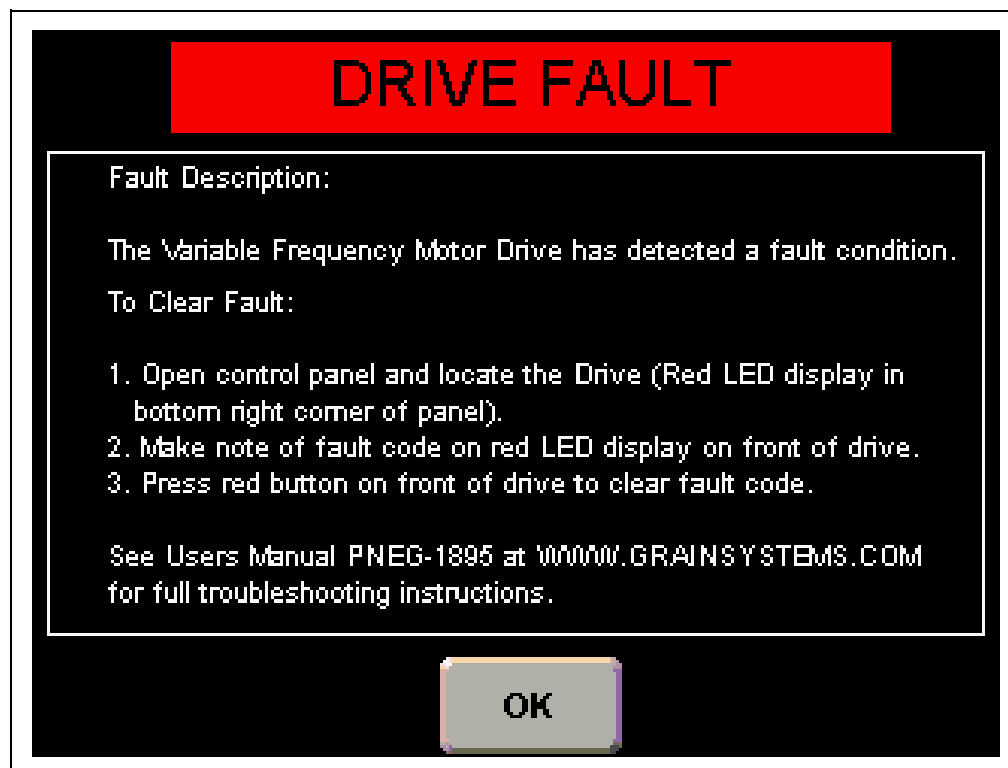

Figure 4V Drive Fault Screen

### Homing Fault Screen

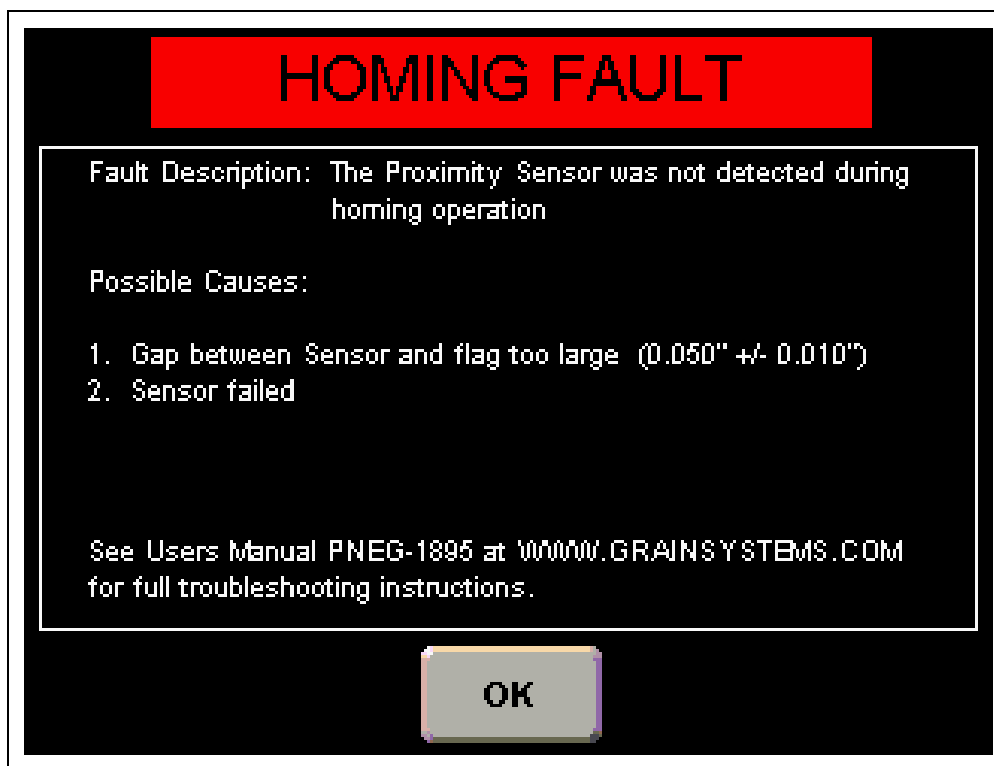

Figure 4W Homing Fault Screen

### Overtravel Fault Screen

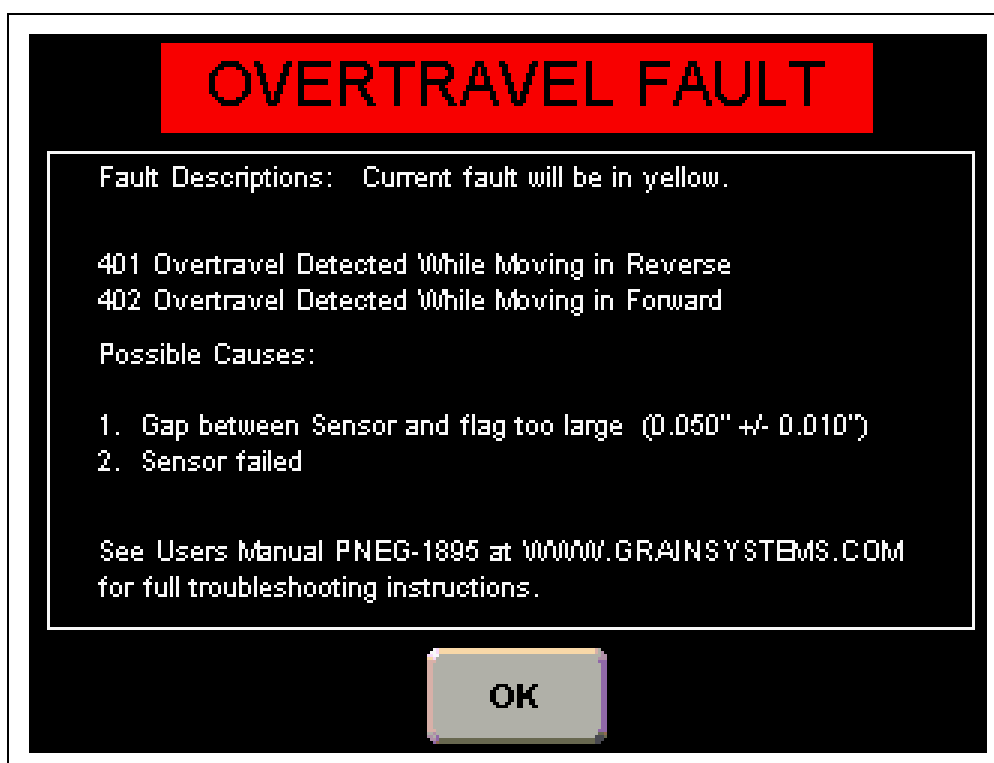

Figure 4X Overtravel Fault Screen

## Direction Fault Screen



Figure 4Y Direction Fault Screen

## Diagnostic Screen

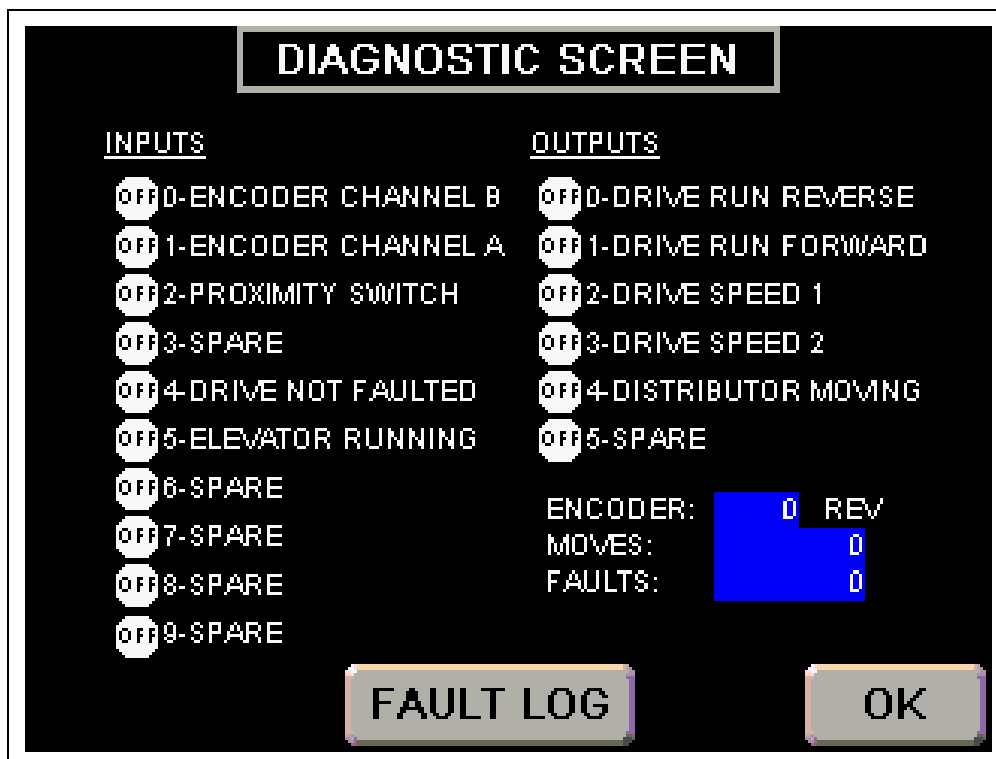

Figure 4Z Diagnostic Screen

## 4. Operation Procedures

### Manual Override

Located on the front of the controller is a manual/jog dial (A). This manual override is key locked and should only be used in case of a major equipment failure. It allows for manually moving the spout in the direction you turn the dial when the key is inserted.

It is recommended that two (2) people perform this procedure. One person to operate the manual/jog dial (A) and another to look through the distributor and verify alignment of the spout. (See Figure 4AA.)

**NOTE:** Panel will not close with key inserted in the manual/jog dial (A). Always keep key in a safe location for access by authorized personnel only.



Figure 4AA

Ref #	Description
A	Manual/Jog Dial

---

# NOTES

# 12" 6 Hole 45° Distributor Assembly Electronic Control (DFB12645G-EC)

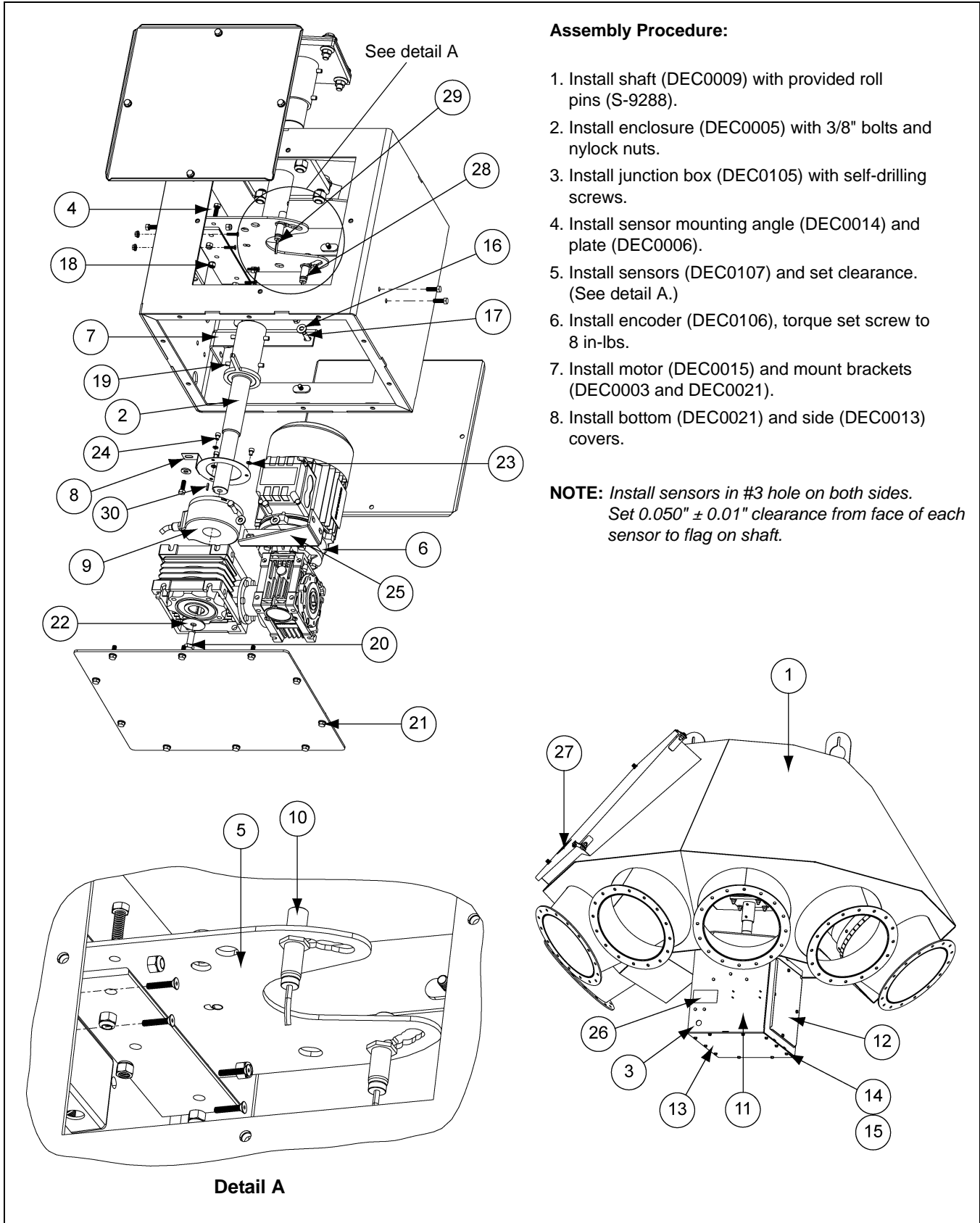

**Assembly Procedure:**

1. Install shaft (DEC0009) with provided roll pins (S-9288).
2. Install enclosure (DEC0005) with 3/8" bolts and nylock nuts.
3. Install junction box (DEC0105) with self-drilling screws.
4. Install sensor mounting angle (DEC0014) and plate (DEC0006).
5. Install sensors (DEC0107) and set clearance. (See detail A.)
6. Install encoder (DEC0106), torque set screw to 8 in-lbs.
7. Install motor (DEC0015) and mount brackets (DEC0003 and DEC0021).
8. Install bottom (DEC0021) and side (DEC0013) covers.

**NOTE:** Install sensors in #3 hole on both sides. Set 0.050" ± 0.01" clearance from face of each sensor to flag on shaft.

## 12" 6 Hole 45° Distributor Assembly Electronic Control (DFB12645G-EC) Parts List

Ref #	Part #	Description	Qty
1	DFB12645G	12" 6 Hole 45° Distributor Assembly	1
2	DEC0009	Weldment, Shaft and Flag, 1/2 HP Distributor Control	1
3	DEC0005	Weldment, Enclosure, 1/2 HP Distributor Control	1
4	DEC0014	Angle, Sensor Plate Mounting, 1/2 HP Distributor Control	1
5	DEC0006	Bracket, Proximity Sensor, 1/2 HP Distributor Control	1
6	DEC0015	Gear Motor, DBL WRM, 1/2 HP, 400:1, Distributor Control	1
7	DEC0003	Bracket, Motor Mount, 1/2 HP Distributor Control	1
8	DEC0016	Bracket, Encoder Mount, Distributor Control	1
9	DEC0106	Encoder, with Connector 2048 PPR, 30 mm, Distributor Control	1
10	DEC0107	Sensor, Prox, Threaded, Inductive, 12 mm, S=4 2	2
11	DEC0105	Connector Box, Farm Distributor Control	1
12	DEC0013	Cover, Side Access, 1/2 HP Distributor Control	2
13	DEC0012	Cover, Enclosure Bottom, 1/2 HP Distributor Control	1
14	S-2041	Split Lock Washer 1/4" ZN	18
15	S-1429	Bolt, HHCS 1/4"-20 x 3/4" ZN Grade 2	29
16	S-2126	Flat Washer 1/4" x 2-5/8" SAE ZN Grade 2	11
17	S-6998	Bolt, HHCS 1/4"-20 x 1" ZN Grade 5	4
18	S-7025	Nylock Nut 1/4"-20 ZN Grade 5	15
19	S-9288	Spring Pin 1/4" x 2-1/2" Plain Steel Slotted Rolled	2
20	S-7469	Bolt, HHCS 3/8"-16 x 1" ZN Grade 5	5
21	S-7383	Nylock Nut 3/8"-16 ZN Grade 5	4
22	S-10200	Fender Washer 3/8" x 1-1/2" O.D. ZN	1
23	S-7223	Split Lock Washer #10 ZN	3
24	S-10167	Bolt, SHCS #10-32 x 1/4" ZN	3
25	DEC0021	Bracket, Motor Mount Short, 1/2 HP Distributor Control	1
26	DC-2160	Decal, Caution, Do not Operate with Access Panel	1
27	DC-2159	Decal, Warning, Rotating Spout can Crush and Cut	1
28	DEC0108	Cable, Home Proximity Sensor Cable Yellow	1
29	DEC0109	Cable, Overtravel Proximity Sensor Cable Black	1
30	DEC0011	Key, 1/4" x 3" L	1
N/S	DEC0110	Panel, V2 Electric Distributor Control	1
N/S	PNEG-1895	Manual, V2 Distributor Electric Control	1

## 6. Retrofit Installation

### Electronic Distributor Control Shaft Installation

Install the shaft (DEC0009) (A) to the distributor shaft (D) using two (2) roll pins (S-9288) (B). **NOTE:** Flag extension (C) should be installed in line with the spout to ensure proper alignment with the sensor. (See Figure 6A.)

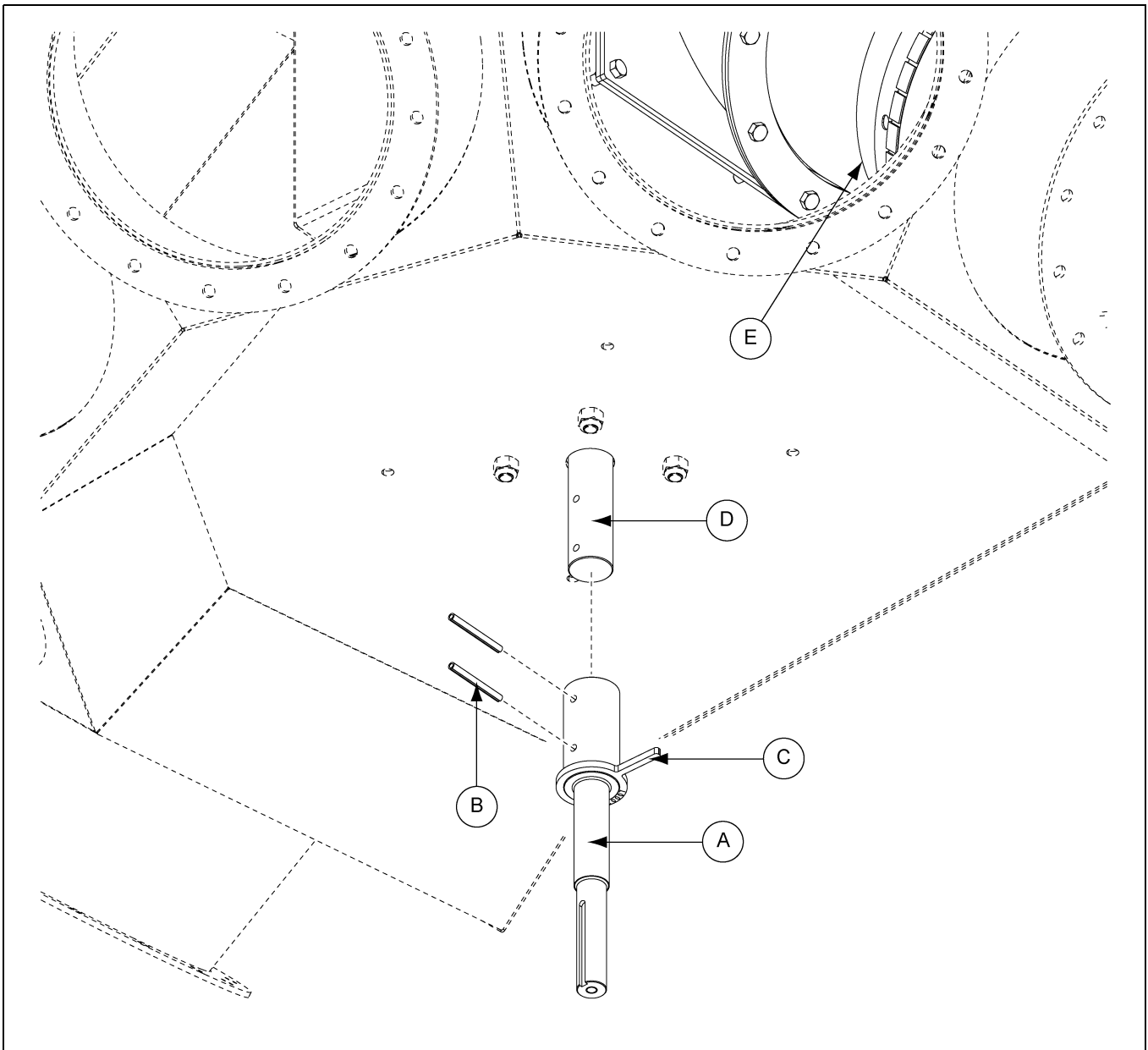

Figure 6A Electronic Distributor Control Shaft

Ref #	Part #	Description
A	DEC0009	Shaft
B	S-9288	Roll Pin
C		Flag Extension
D		Distributor Shaft
E		Spout



## Electronic Distributor Enclosure Installation

Install the enclosure (DEC0005) to the distributor (C) using four (4) 3/8 bolts (S-7469) (B) and nylock nuts (S-7383) (A). (See Figure 6B.) Note the orientation of the enclosure; the side with the two (2) large holes must face away from back wall of distributor. Controller will not work if installed backwards.

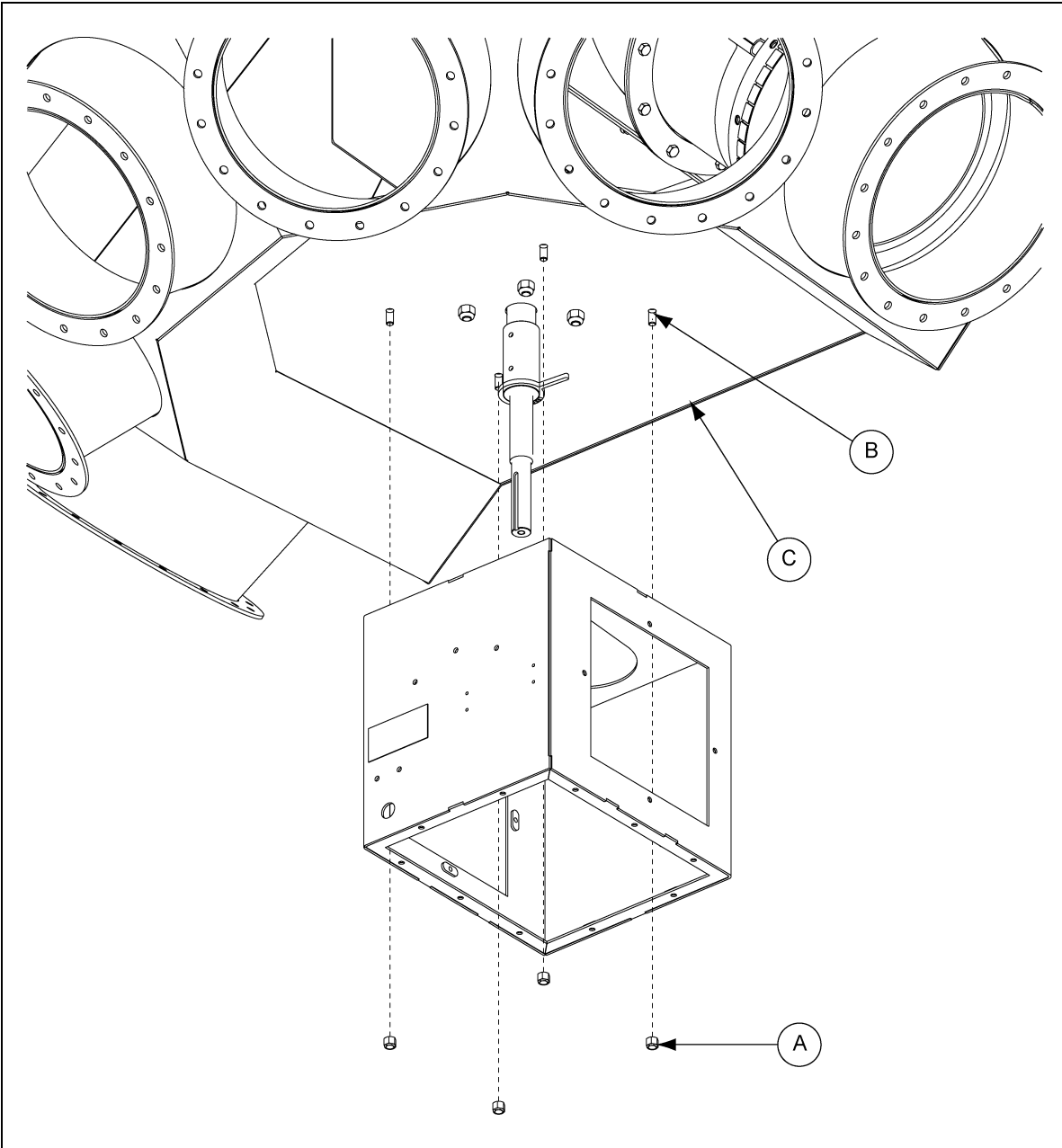

**Figure 6B** *Electronic Distributor Enclosure*

Ref #	Part #	Description
A	S-7383	3/8" Nylock Nut
B	S-7469	3/8" Bolt
C		Distributor

## 6. Retrofit Installation

### Sensor Plate Angle and Proximity Sensor Bracket Installation

Assemble the sensor plate angle (DEC0014) (A) to the proximity sensor bracket (DEC0006) (D) using three (3) 1/4"-20 x 3/4" HHCS bolts (S-1429) (B) and 1/4"-20 nylock nuts (S-7025) (C) as shown in [Figure 6C](#).

Attach the proximity sensor bracket (DEC0006) (D) to the inside of the enclosure (DEC0005) (E) using three (3) 1/4"-20 x 3/4" HHCS bolts (S-1429) (B) and 1/4"-20 nylock nuts (S-7025) (C). ([See Figure 6C.](#)) Bracket must be installed with note markings facing down.

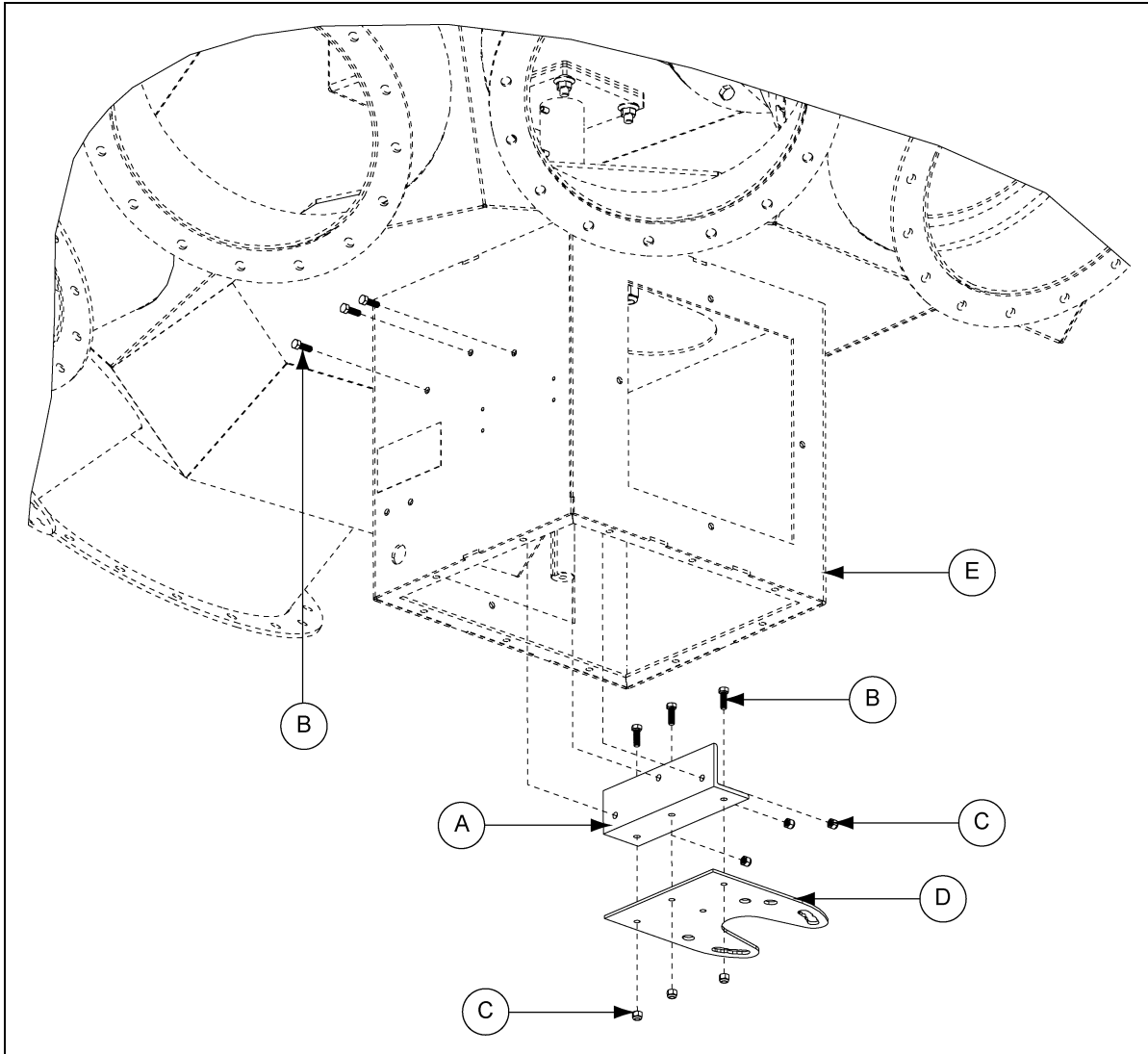

**Figure 6C** Sensor Plate Angle and Proximity Sensor Bracket

Ref #	Part #	Description
A	DEC0014	Sensor Plate Angle
B	S-1429	1/4"-20 x 3/4" HHCS Bolt
C	S-7025	1/4"-20 Nylock Nut
D	DEC0006	Proximity Sensor Bracket
E	DEC0005	Enclosure

## Proximity Sensor Location and Installation

**NOTE:** The location of the proximity sensor will be determined by the configuration of the distributor. Using the table shown in [Figure 6D](#), locate the diameter and number of spouts of the distributor being used and note the proximity sensor reference number. This reference number is marked on the bottom of the proximity sensor bracket (DEC0006) (B) and identifies the location for installing the proximity sensors (DEC0107) (A).

Install the two (2) proximity sensors (DEC0107) (A) into the proximity sensor bracket (DEC0006) (B) at the appropriate locations determined from the table. (See [Figure 6D](#) below and [Figure 6E](#) on Page 44.)

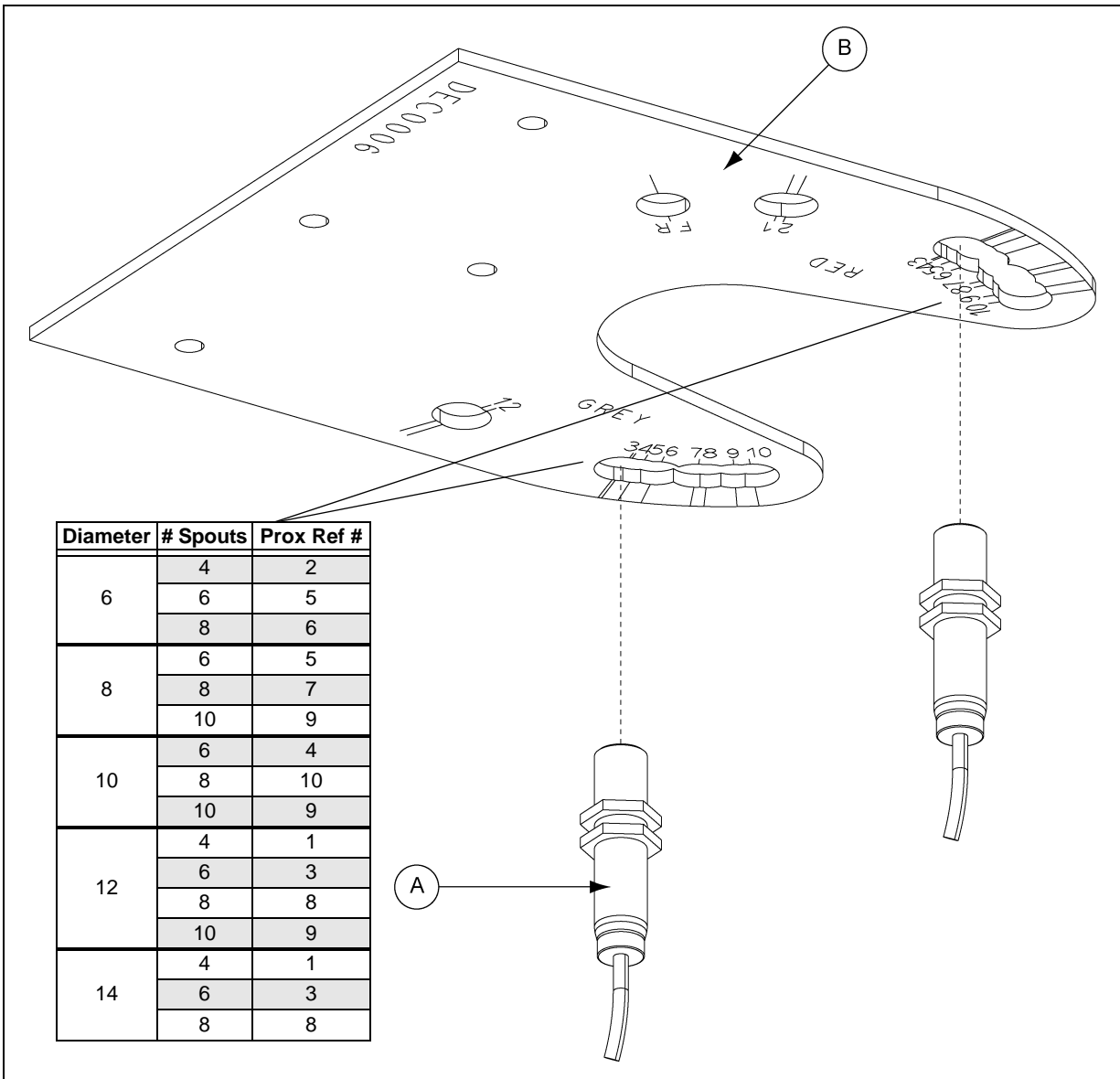

Figure 6D Proximity Sensor Location

Ref #	Part #	Description
A	DEC0107	Proximity Sensor
B	DEC0006	Proximity Sensor Bracket

Proximity Sensor Location and Installation (Continued)

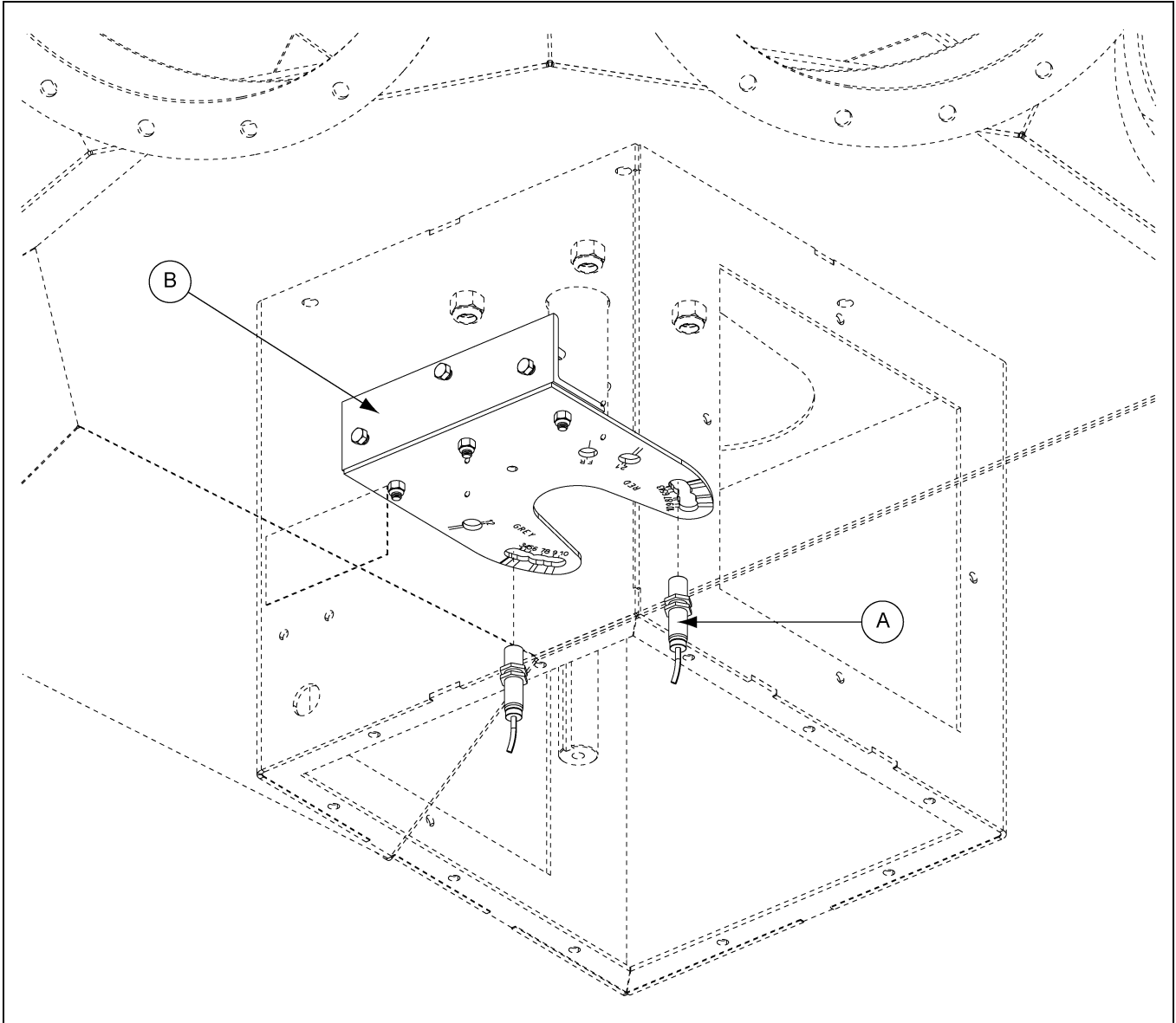
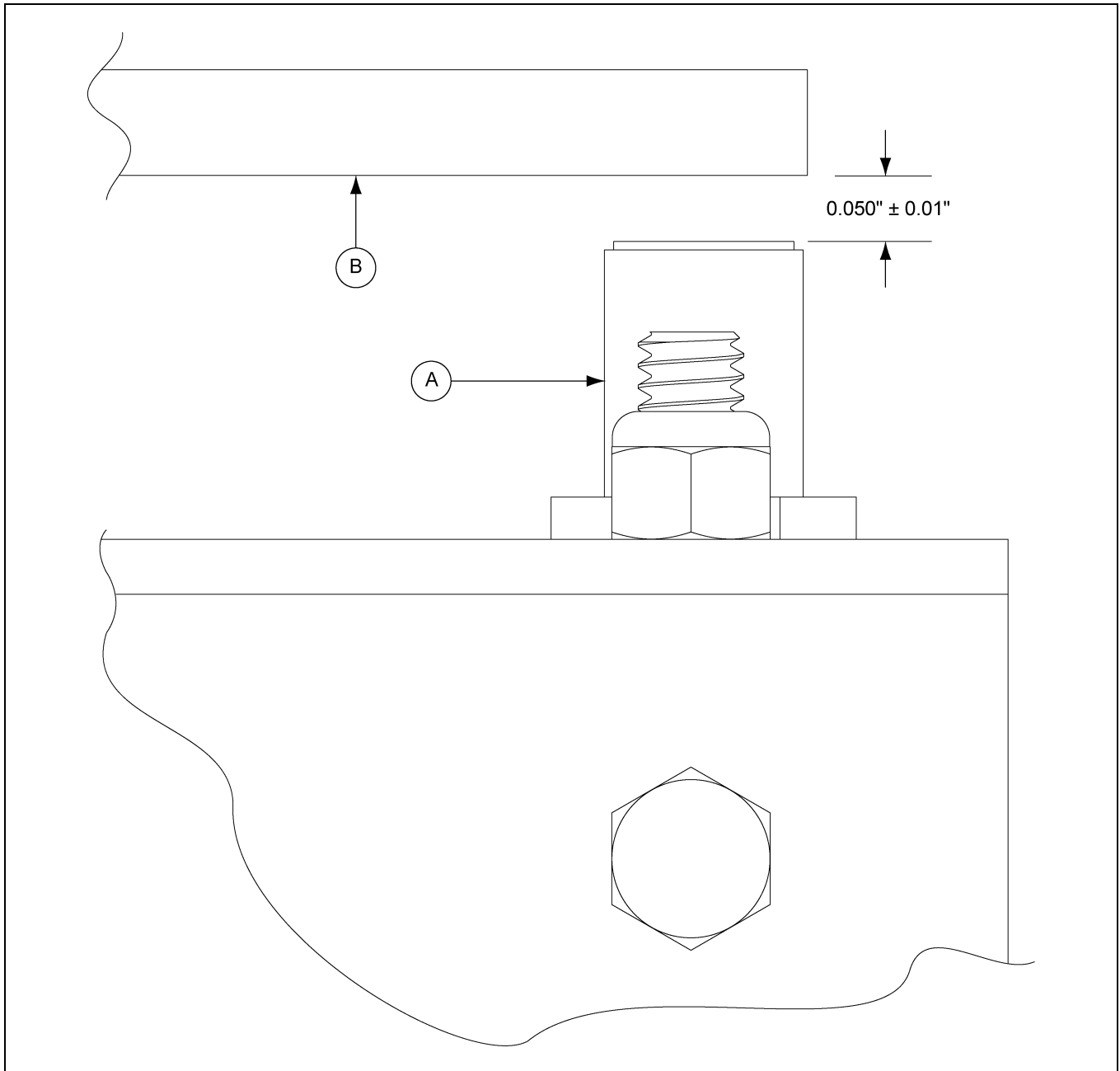

Figure 6E Proximity Sensor Installation

Ref #	Part #	Description
A	DEC0107	Proximity Sensor
B	DEC0006	Proximity Sensor Bracket

## Proximity Sensor Adjustment

Set the clearance of the two (2) proximity sensors (DEC0107) (A) to  $0.050" \pm 0.01"$  from the face of each sensor to the flag (B) on the shaft (DEC0009). (See Figure 6F.) This adjustment may need to be made after motor is wired by using manual key switch to locate flag above each proximity sensor.



**Figure 6F** Proximity Sensor Adjustment

Ref #	Part #	Description
A	DEC0107	Proximity Sensor
B		Flag

## 6. Retrofit Installation

### Encoder and Bracket Installation

Install the encoder (DEC0106) (A) to the encoder mounting bracket (DEC0016) (B) using the three (3) #10-32 bolts (S-10167) (D) and #10 washers (S-7223) (C) as shown in [Figure 6G](#).

Tighten the encoder collar set screw (E) as shown in [Figure 6H on Page 47](#) to 8 in-lbs.

Install the encoder mounting bracket (DEC0016) (B) to the proximity sensor bracket (DEC0006) (H) using the 1/4"-20 x 3/4" HHCS bolt (S-1429) (I), 1/4" washer (S-2126) (J) and 1/4"-20 nylock nut (S-7025) (K) as shown in [Figure 6I on Page 48](#).

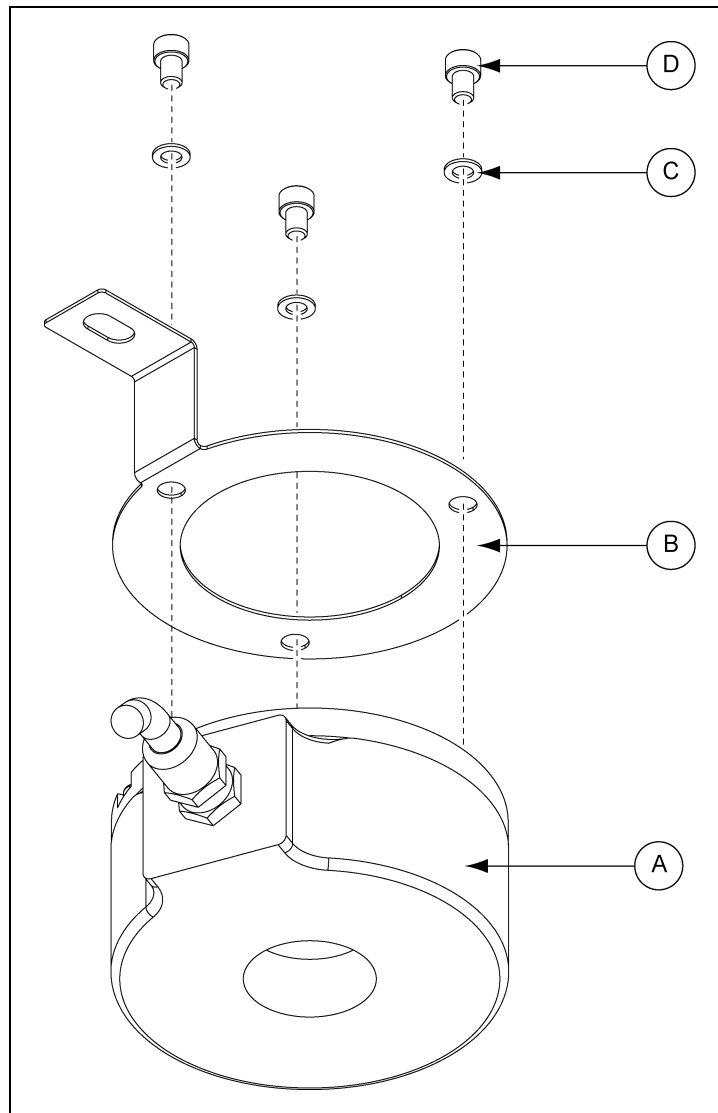

**Figure 6G** Encoder to Mounting Bracket

Ref #	Part #	Description
A	DEC0106	Encoder
B	DEC0016	Encoder Mounting Bracket
C	S-7223	#10 Washer
D	S-10167	#10-32 Bolt

## Encoder and Bracket Installation (Continued)

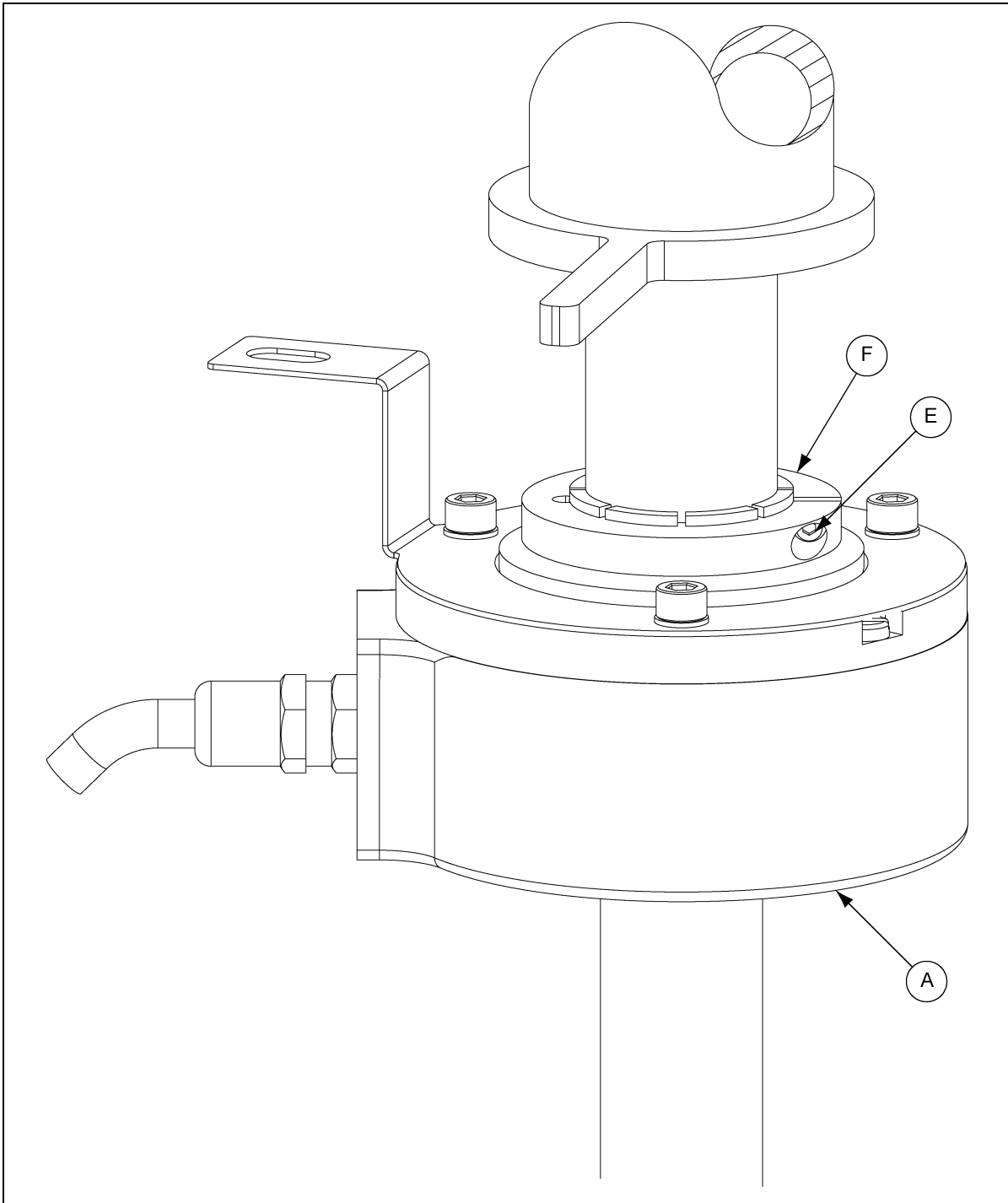
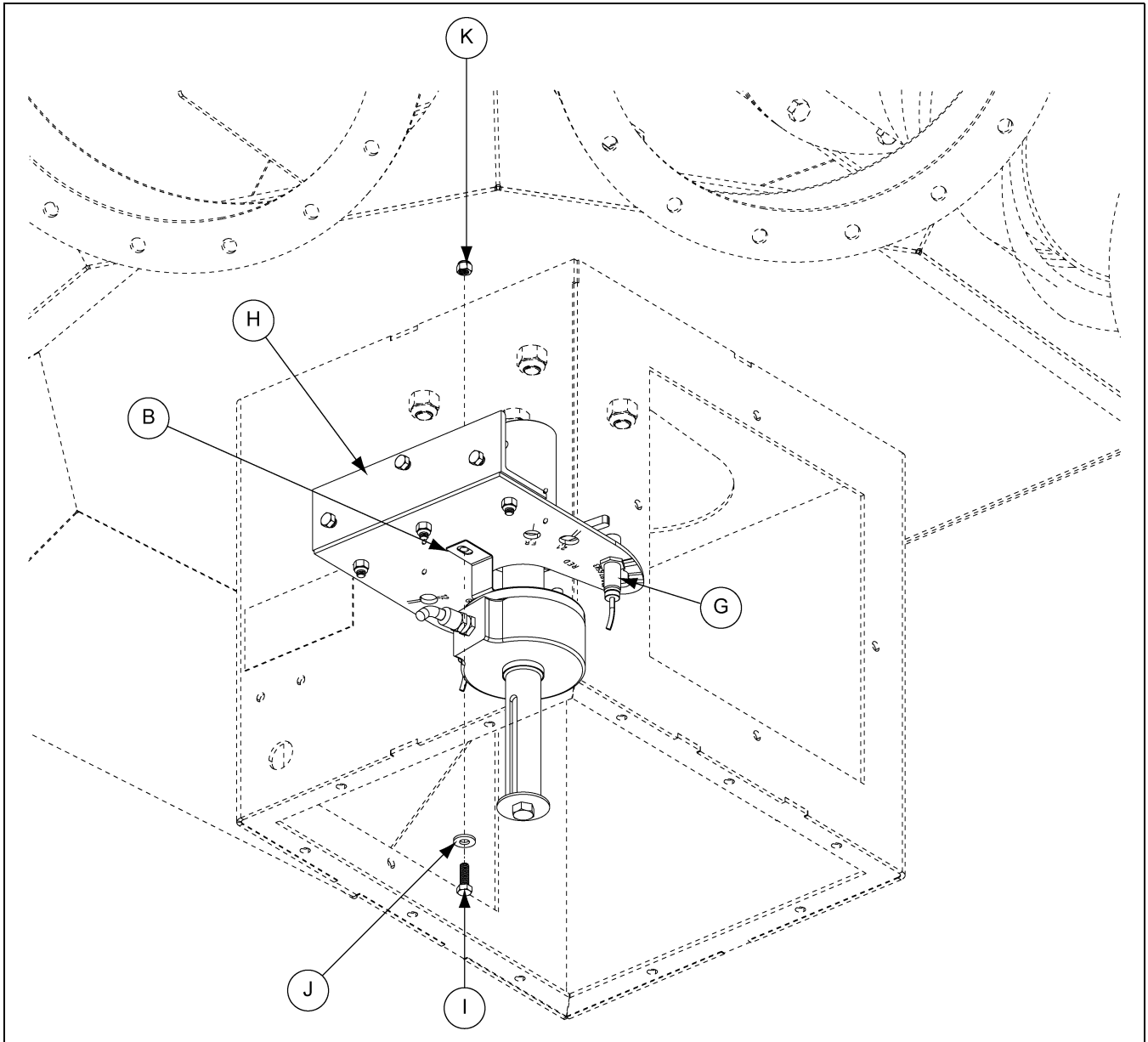

Figure 6H Encoder Collar Set Screw

Ref #	Part #	Description
A	DEC0106	Encoder
E		Encoder Collar Set Screw
F		Encoder Collar

## Encoder and Bracket Installation (Continued)



**Figure 6I** Connector Box Install, Sensor Connectors to Encoder Connection

Ref #	Part #	Description
B	DEC0016	Encoder Mounting Bracket
G	DEC0107	Proximity Sensor
H	DEC0006	Proximity Sensor Bracket
I	S-1429	1/4"-20 x 3/4" HHCS Bolt
J	S-2126	1/4" Washer
K	S-7025	1/4"-20 Nylock Nut



## Installing the Connector Box and Cables

1. Install the connector box to the inside of the enclosure using four (4) bolts (B) and nuts (C). Make sure nuts are located on the outside of the enclosure. (See Figure 6J.)

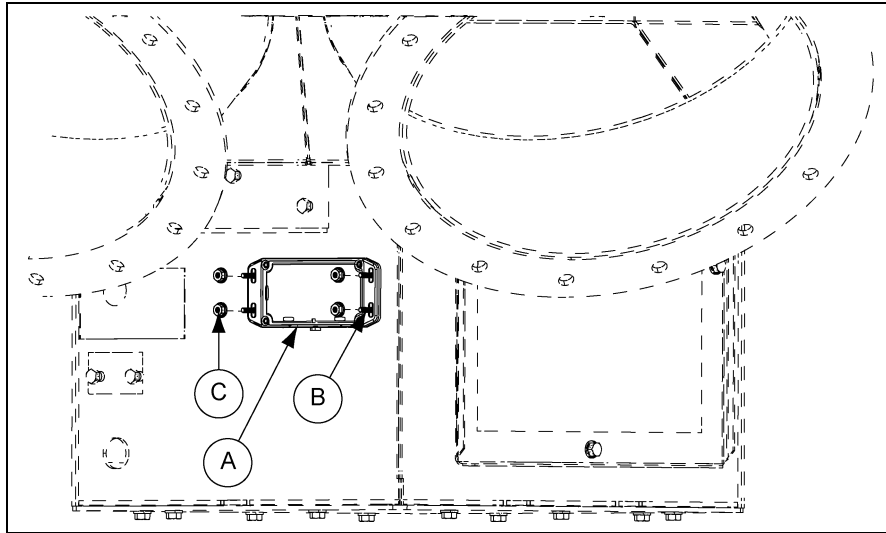

Figure 6J

2. Pull sensor cable through the conduit connected to the enclosure.
3. Connect cables to the connector enclosure. (See Figure 6K.)

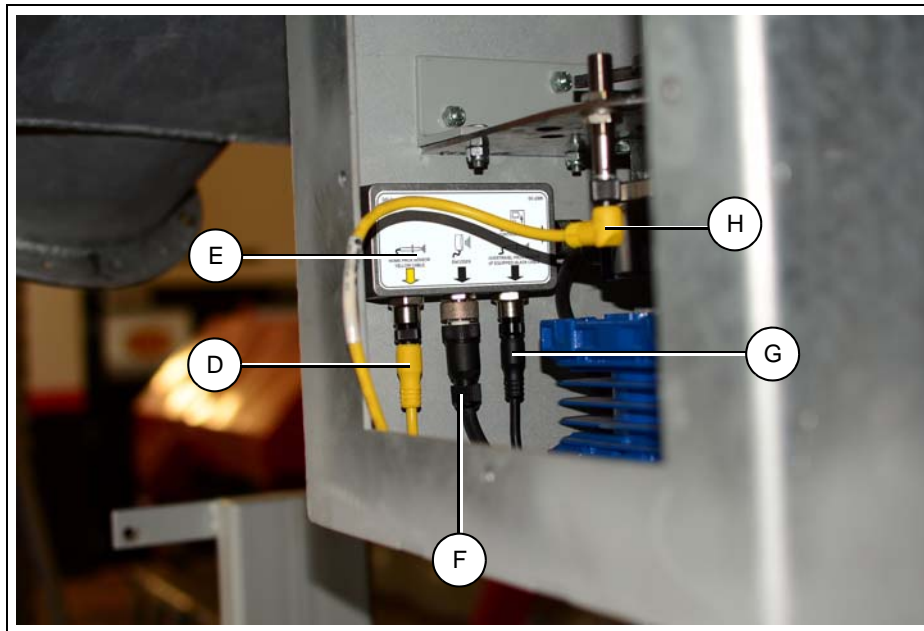

Figure 6K Control Panel Wiring to Junction Box Electrical Connections

Ref #	Part #	Description
A		Enclosure
B		Bolts
C		Nuts
D	DEC0108	Home Proximity Sensor Cable

Ref #	Part #	Description
E	DEC0105	Connection Enclosure
F	DEC0106	Encoder
G	DEC0109	Over-Travel Proximity Sensor Cable
H	DEC0026-XXX	Sensor Cable

**NOTE:** "XXX" represent the length of the cable.

## 6. Retrofit Installation

### Motor Mounting Bracket Installation

Install the motor mounting bracket (DEC0003) (A) to the enclosure (DEC0005) (E) using two (2) 1/4"-20 x 3/4" HHCS bolts (S-1429) (D), 1/4" washers (S-2126) (C) and 1/4"-20 nylock nuts (S-7025) (B) as shown in [Figure 6L](#).

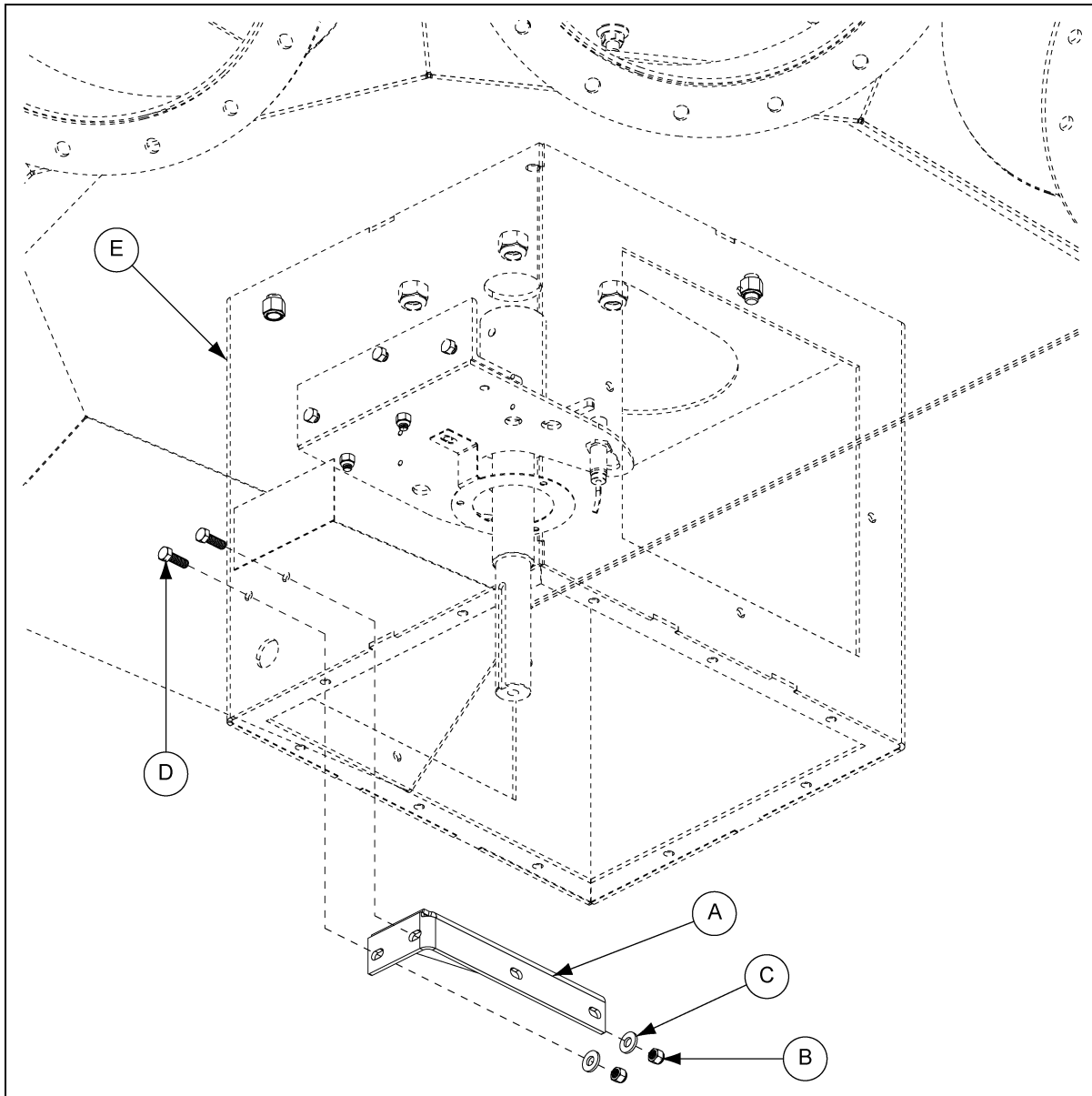

Figure 6L Motor Mounting Bracket

Ref #	Part #	Description
A	DEC0003	Motor Mounting Bracket
B	S-7025	1/4"-20 Nylock Nut
C	S-2126	1/4" Washer
D	S-1429	1/4"-20 x 3/4" HHCS Bolt
E	DEC0005	Enclosure

## Control Motor Installation

Install the motor (DEC0015) (A) to the motor mounting bracket (DEC0003) (F) using two (2) 1/4"-20 x 1" HHCS bolts (S-6998), four (4) 1/4" washers (S-2126) (D) and two (2) 1/4"-20 nylock nuts (S-7025) (C) as shown in [Figure 6M](#).

Install second motor mounting bracket (DEC0021) (B) to the enclosure (DEC0005) using two (2) 1/4"-20 x 3/4" HHCS bolts (S-1429) (E), 1/4" washers (S-2126) (D) and 1/4"-20 nylock nuts (S-7025) (C). Then install the motor to the motor mounting bracket (DEC0021) (B) using two (2) 1/4"-20 x 1" HHCS bolts (S-6998), four (4) 1/4" washers (S-2126) (D) and two (2) 1/4"-20 nylock nuts (S-7025) (C) as shown in [Figure 6M](#).

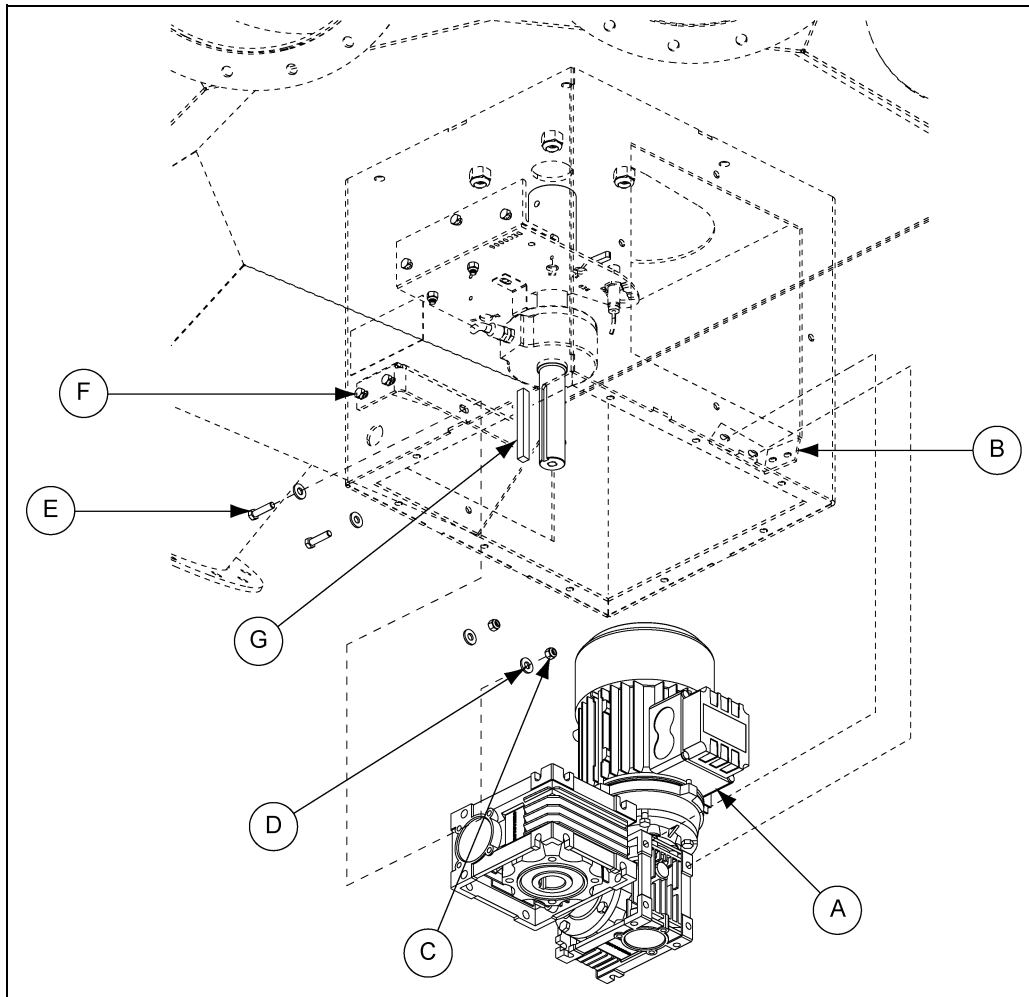

**Figure 6M** Control Motor Installation

Ref #	Part #	Description
A	DEC0015	Motor
B	DEC0021	Motor Mounting Bracket - Short
C	S-7025	1/4"-20 Nylock Nut
D	S-2126	1/4" Washers
E	S-1429	1/4"-20 x 1" HHCS Bolt
F	DEC0003	Motor Mounting Bracket
G	DEC0011	Key

### Error Messages

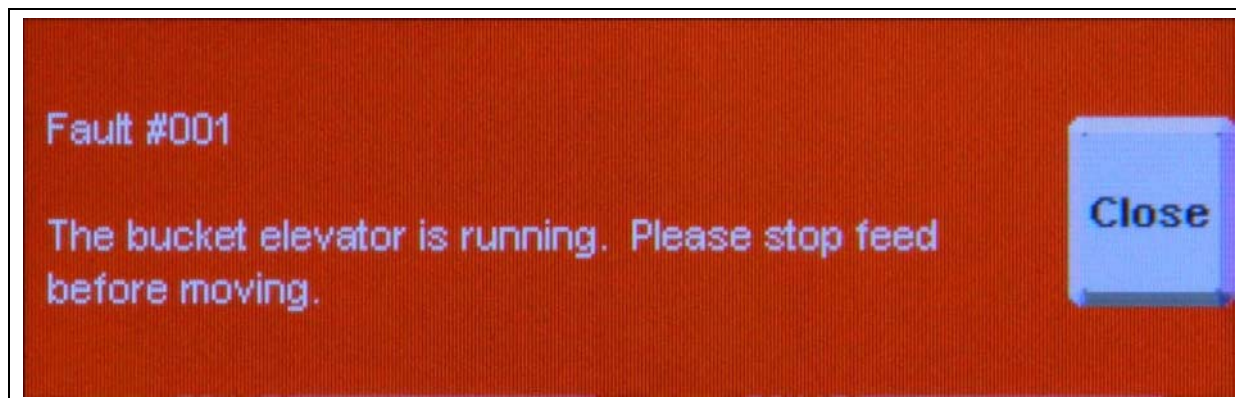

Figure 7A

**Cause:** When using the supplied interlock function, this message will appear when a move is attempted while the contact closure that indicates that upstream equipment is running is closed. The move will complete once the contact closure opens indicating the upstream equipment is no longer running.

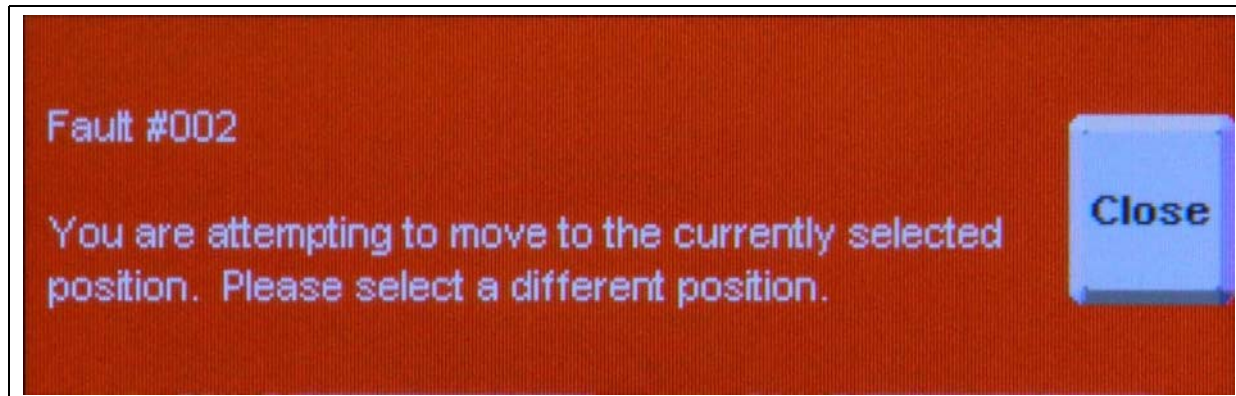

Figure 7B

**Cause:** This message will appear if the user attempts to move to the position where the distributor is currently located. If a different position is desired, the user must select a different position.

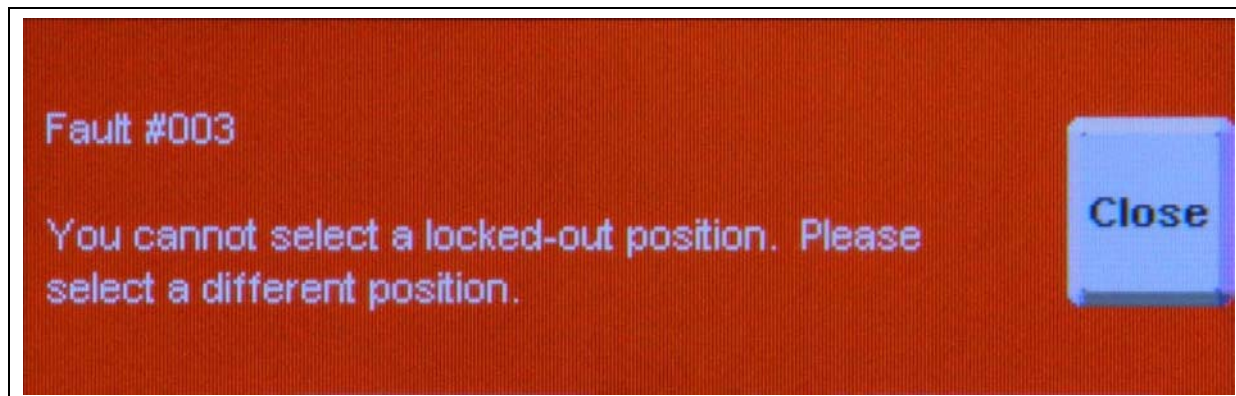

Figure 7C

**Cause:** This message will appear if the user attempts to move to a position that has been configured as "locked-out." If this position is desired, it must first be unlocked by navigating to "Position Lock-Out" screen in the setup menu.

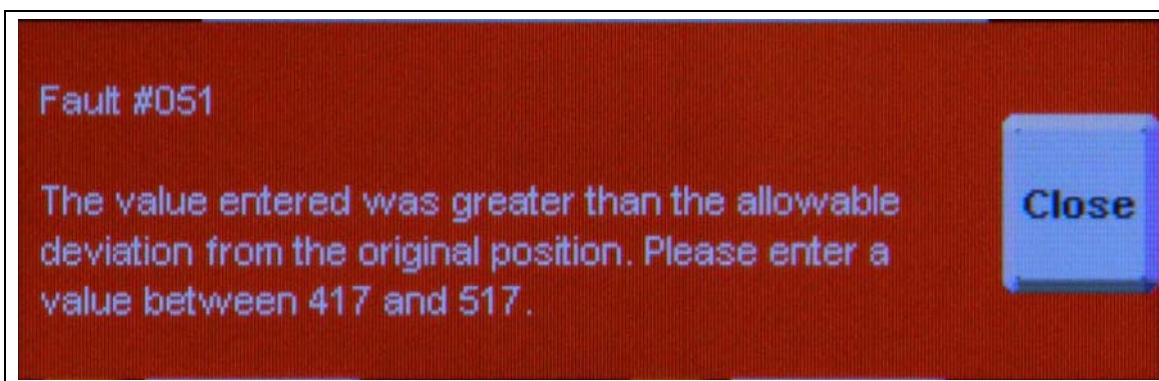

Figure 7D

**Cause:** This message will appear if the user attempts to enter a position location value that is outside the range of values allowed by the controller. This range exists to protect the equipment. To prevent this message, user should enter a value that is within the range of values displayed in the error message. (These values will vary for each controller; the values shown *in Figure 7D* will not be representative of all configurations.)

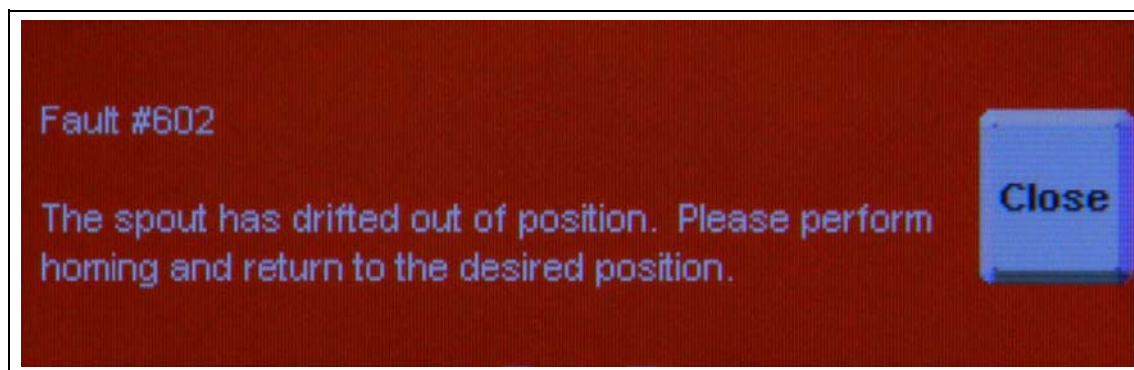

Figure 7E

**Cause:** This message will appear if the controller has sensed that the spout has drifted from its desired position while not being commanded to move. This may be caused by mechanical lash within the drive mechanism or by the use of the manual key switch override on the front of the panel. User should execute a "Move" command (see moving positions *on Page 22*) before attempting to move material through distributor. Controller should force a homing operation before completing the move command.

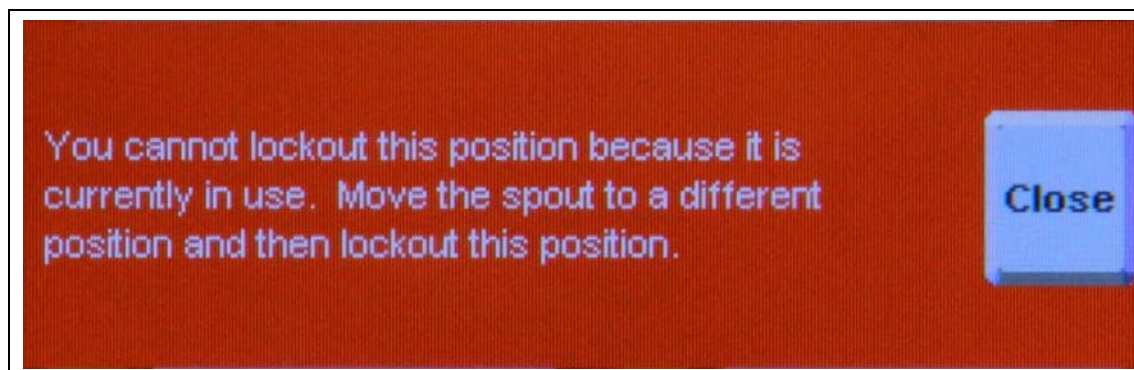

Figure 7F

**Cause:** This message will be displayed if the user attempts to select the position where the distributor is currently located to be locked-out. If this position is desired for lock-out, a "Move" command (see moving positions *on Page 22*) should be performed to change to another position before selecting the position for lock-out.

## Fault Code Descriptions, Possible Causes and Solutions

Code	Fault Type	Description	Cause	Solution
101	Direction	Motor Direction Forward, Encoder Reading Reverse	Motor wiring or encoder signal wiring is reversed.	Using manual key switch, verify that forward command produces counter-clockwise (as observed from above) distributor rotation. If distributor rotates clockwise (as observed from above), swap any two (2) motor leads to reverse motor rotation direction. If motor direction is correct, check blue terminals 3 and 4 for correct wiring both at junction box and control panel.
102	Direction	Motor Direction Reverse, Encoder Reading Forward	Motor wiring or encoder signal wiring is reversed.	Using manual key switch, verify that forward command produces counter-clockwise (as observed from above) distributor rotation. If distributor rotates clockwise (as observed from above), swap any two (2) motor leads to reverse motor rotation direction. If motor direction is correct, check blue terminals 3 and 4 for correct wiring both at junction box and control panel.
201	Encoder	Encoder Channel A is OFF, Encoder Channel B is OFF	Controller is detecting no signal from encoder channel A or encoder channel B.	Verify encoder wiring per instructions in this manual. Encoder connections are blue terminal blocks. Blue terminal block #1 should be connected to red encoder wire. Blue terminal block #2 should be connected to blue encoder wire. Blue terminal block #3 should be connected to pink encoder wire. Blue terminal block #4 should be connected to white encoder wire.
202	Encoder	Encoder Channel A is OFF, Encoder Channel B is ON	Controller is detecting no signal from encoder channel A, channel B is always ON.	Controller is receiving no signal from channel A (blue terminal block #3) and a constant signal from channel B (blue terminal block #4). Verify encoder wiring as referenced above and ensure all terminal blocks are secure with proper electrical continuity. If wiring is correct and all terminals have continuity, check for 24V across terminals 1 and 2. If encoder has 24V power and problem persists the encoder has likely failed. Replace encoder.
203	Encoder	Encoder Channel A is ON, Encoder Channel B is OFF	Controller is detecting encoder channel A always ON, channel B no signal.	Controller is receiving a constant signal from channel A (blue terminal block #3) and no signal from channel B (blue terminal block #4). Verify encoder wiring as referenced above and ensure all terminal blocks are secure with proper electrical continuity. If wiring is correct and all terminals have continuity, check for 24V across terminals 1 and 2. If encoder has 24V power and problem persists the encoder has likely failed. Replace encoder.
204	Encoder	Encoder Channel A is ON, Encoder Channel B is ON	Controller is detecting encoder channel A and channel B always ON.	Controller is receiving a constant signal from channel A (blue terminal block #3) and a constant signal from channel b (blue terminal block #4). Verify that encoder ground (blue terminal block #2) is secure with proper electrical continuity at all terminations. If wiring is correct and all terminals have continuity, check for 24V across terminals 1 and 2. If encoder has 24V power and problem persists the encoder has likely failed. Replace encoder.

## Fault Code Descriptions, Possible Causes and Solutions (Continued)

Code	Fault Type	Description	Cause	Solution
205	Encoder	Encoder Channel A is OFF, Encoder Channel B is OK	Controller is detecting no signal from encoder channel A, channel B is functioning normally.	Controller is receiving no signal from channel A (blue terminal block #3) and a normal pulsing signal from channel B (blue terminal block #4). Verify that blue terminal block #3 has proper electrical continuity and that connections are secure. If wiring is correct and all terminals have continuity, check for 24V across terminals 1 and 2. If encoder has 24V power and problem persists the encoder has likely failed. Replace encoder.
206	Encoder	Encoder Channel A is ON, Encoder Channel B is OK	Controller is detecting encoder channel A always ON, channel B is functioning normally.	Controller is receiving a constant signal from channel A (blue terminal block #3) and a normal pulsing signal from channel B (blue terminal block #4). Verify that blue terminal block #3 has no short present in that circuit and that connections are secure. If wiring is correct and all terminals have continuity, check for 24V across terminals 1 and 2. If encoder has 24V power and problem persists the encoder has likely failed. Replace encoder.
207	Encoder	Encoder Channel A is OK, Encoder Channel B is OFF	Controller is detecting encoder channel A functioning normally, channel B no signal.	Controller is receiving a normal pulsing signal from channel A (blue terminal block #3) and no signal from channel B (blue terminal block #4). Verify that blue terminal block #4 has proper electrical continuity and that connections are secure. If wiring is correct and all terminals have continuity, check for 24V across terminals 1 and 2. If encoder has 24V power and problem persists the encoder has likely failed. Replace encoder.
208	Encoder	Encoder Channel A is OK, Encoder Channel B is ON	Controller is detecting encoder channel A functioning normally, channel B always ON.	Controller is receiving a normal pulsing signal from channel A (blue terminal block #3) and a constant signal from channel B (blue terminal block #4). Verify that blue terminal block #4 has no short present in that circuit and that connections are secure. If wiring is correct and all terminals have continuity, check for 24V across terminals 1 and 2. If encoder has 24V power and problem persists the encoder has likely failed. Replace encoder.
301	VFD	Variable frequency electric motor drive has faulted.	VFD has detected a malfunction while driving the electric motor.	Open control panel and observe red LCD display screen on power flex Variable Frequency Drive (VFD). this display should show a numbered fault code corresponding to the malfunction. Press red button to reset fault and consult manufacturer's technical manual for full description of fault.

## Fault Code Descriptions, Possible Causes and Solutions (Continued)

Code	Fault Type	Description	Cause	Solution
401	Overtravel	Overtravel left (home side) detected during position move.	Controller has detected signal indicating spout has traveled past position #1 toward back wall.	Controller has received a signal from proximity sensor on home side of assembly (noted as "red" on sensor mounting plate and run to red terminal blocks) during a position move, indicating spout has overtraveled expected position. Verify that proximity sensors are in correct numbered positions on mounting plate ( <a href="#">See Page 43</a> ), are wired to the correct terminal blocks and that no metal objects are within 2 mm (0.080") of the black plastic sensing surface. Metal flag welded to shaft should only pass over home proximity sensor during a homing procedure. Flag should trigger proximity sensor after passing position #1 toward back wall of distributor, just before internal spout makes contact with back wall.
402	Overtravel	Overtravel right detected during position move.	Controller has detected signal indicating spout has traveled past last position toward back wall.	Controller has received a signal from proximity sensor on far side of assembly (noted as "grey" on sensor mounting plate and run to grey terminal blocks) during a position move, indicating spout has overtraveled expected position. Verify that proximity sensors are in correct numbered positions on mounting plate ( <a href="#">See Page 43</a> ), are wired to the correct terminal blocks and that no metal objects are within 2 mm (0.080") of the black plastic sensing surface. Metal flag welded to shaft should never pass over overtravel proximity sensor during normal operation. Flag should trigger sensor only if spout has traveled past the last position.
501	Encoder	Homing operation has timed out before completion.	Controller did not receive signal from home proximity sensor within the maximum allowable time limit.	Homing operation rotates distributor spout to a position between the back wall of the distributor and the center of the #1 position to set a constant zero point. If controller does not receive signal from home proximity sensor within a pre-defined time limit, homing operation fails. This may be caused by a mechanical obstacle stopping rotation or by the sensor not being triggered by the metal flag welded to the drive shaft. If the gap between the proximity sensor and the flag welded to the drive shaft is too large, the sensor will not trigger and homing will fail. Verify that the gap between sensor and flag is 0.050" ± 0.010". Manual key switch may be used to check this. If gap is correct and red LED light on sensor illuminates in presence of shaft flag, verify that the sensor is wired to the correct red terminal blocks, and that diagnostic screen shows home prox "on" when flag is over top of sensor.
601	Encoder	System has detected a change in position without a move command from PLC.	Controller has measured movement of spout assembly without user input. This may be caused by use of the manual/key switch override or by other mechanical issue.	If fault is caused by use of key switch, distributor may be returned to a position by performing a "move" command from move screen. Distributor will force a homing operation before completing move command to ensure accurate positioning. Controller should return spout to the selected position on completion of homing.



# White Panel Layout

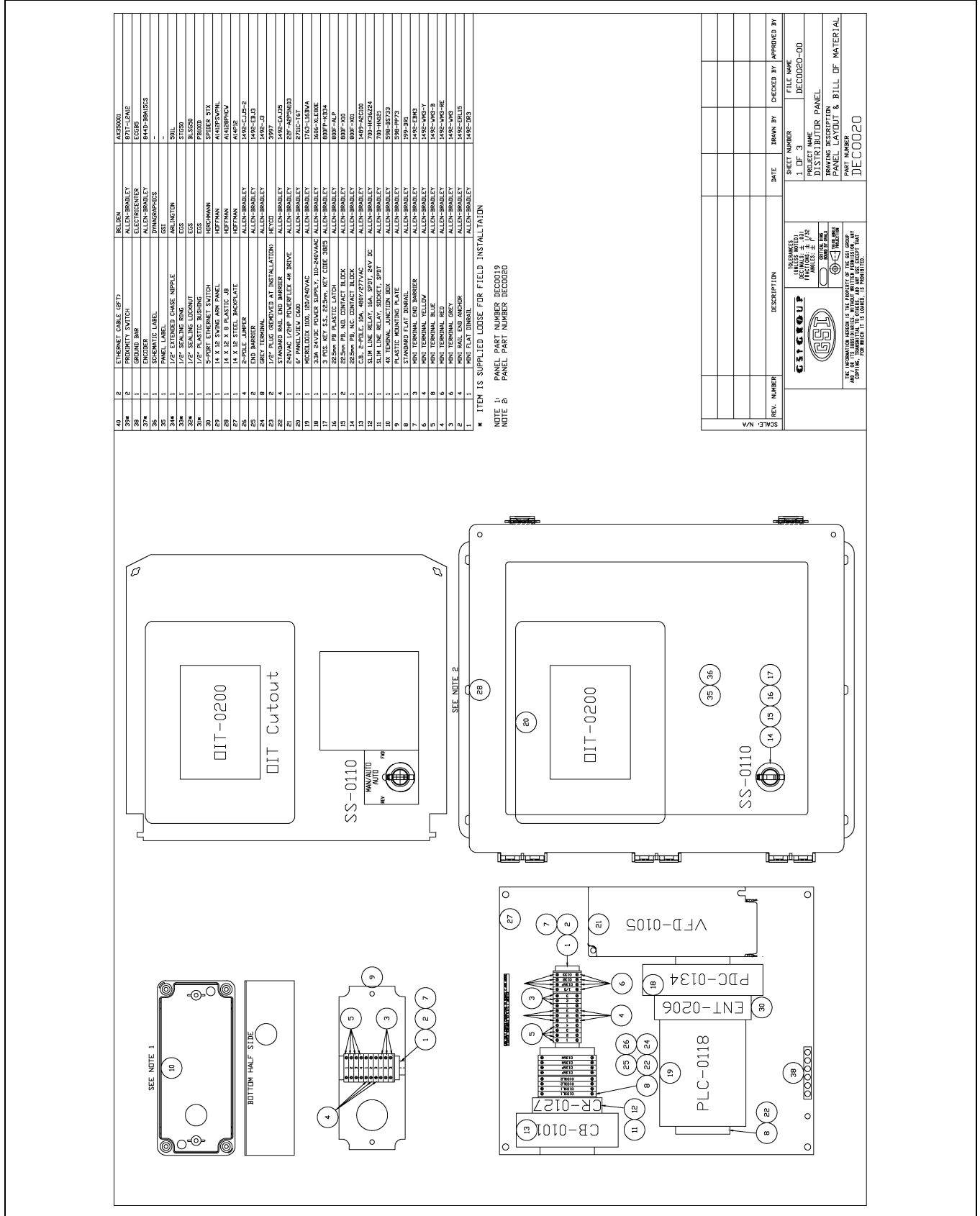

Figure 8A

# 8. Schematic and Wiring Diagrams

## White Panel Electrical Schematic

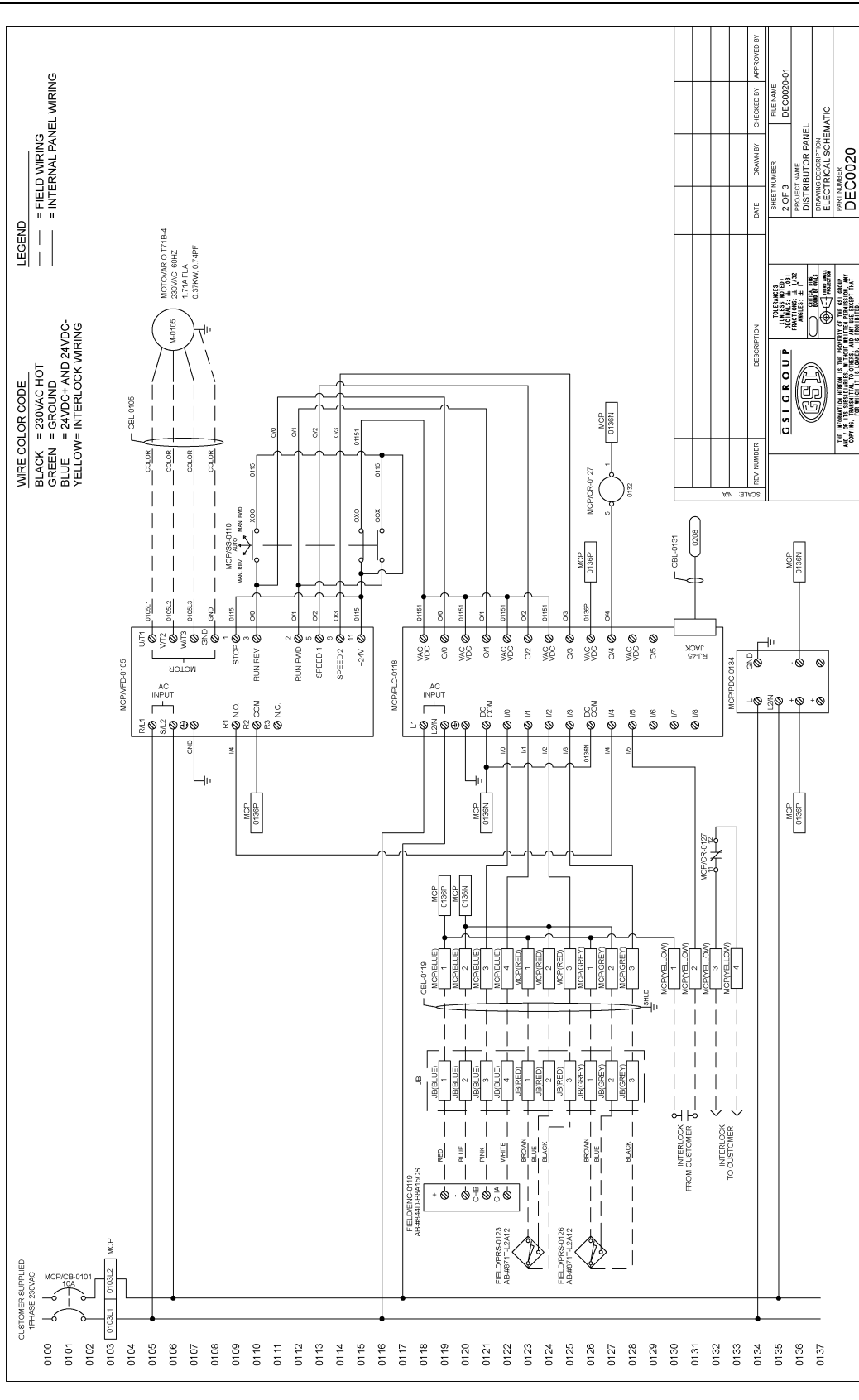

Figure 8B

# White Panel Electrical Schematic (Continued)

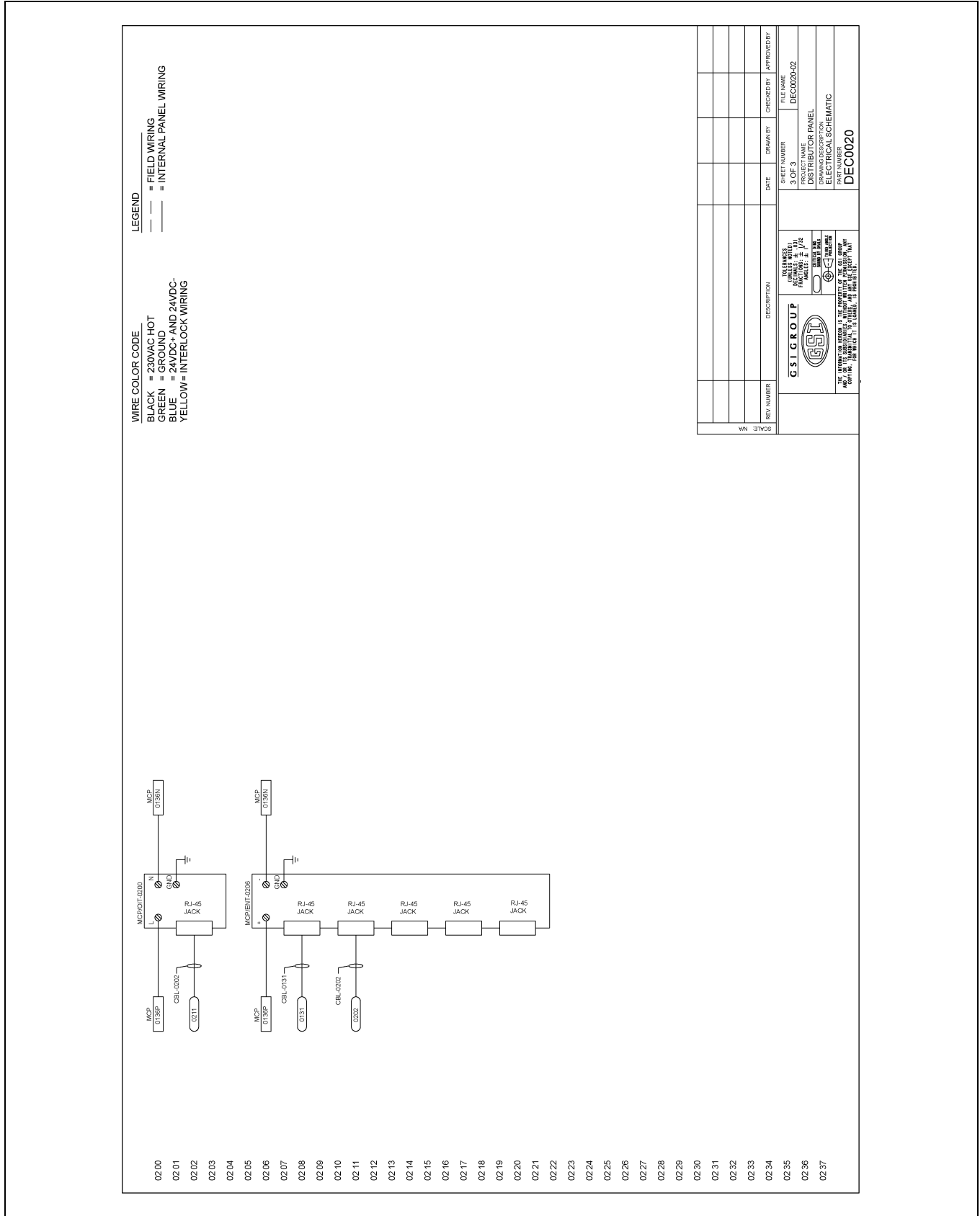

Figure 8C

---

# NOTES

## GSI Group, LLC Limited Warranty

The GSI Group, LLC ("GSI") warrants products which it manufactures to be free of defects in materials and workmanship under normal usage and conditions for a period of 12 months after sale to the original end-user or if a foreign sale, 14 months from arrival at port of discharge, whichever is earlier. The end-user's sole remedy (and GSI's only obligation) is to repair or replace, at GSI's option and expense, products that in GSI's judgment, contain a material defect in materials or workmanship. Expenses incurred by or on behalf of the end-user without prior written authorization from the GSI Warranty Group shall be the sole responsibility of the end-user.

### Warranty Extensions:

The Limited Warranty period is extended for the following products:

	Product	Warranty Period
<b>AP Fans and Flooring</b>	Performer Series Direct Drive Fan Motor	3 Years
	All Fiberglass Housings	Lifetime
	All Fiberglass Propellers	Lifetime
<b>Cumberland Feeding/Watering Systems</b>	Feeder System Pan Assemblies	5 Years **
	Feed Tubes (1-3/4" and 2.00")	10 Years *
	Centerless Augers	10 Years *
	Watering Nipples	10 Years *
<b>Grain Systems</b>	Grain Bin Structural Design	5 Years
<b>Grain Systems Farm Fans Zimmerman</b>	Portable and Tower Dryers	2 Years
	Portable and Tower Dryer Frames and Internal Infrastructure †	5 Years

\* Warranty prorated from list price:  
 0 to 3 years - no cost to end-user  
 3 to 5 years - end-user pays 25%  
 5 to 7 years - end-user pays 50%  
 7 to 10 years - end-user pays 75%

\*\* Warranty prorated from list price:  
 0 to 3 years - no cost to end-user  
 3 to 5 years - end-user pays 50%

† Motors, burner components and moving parts not included. Portable dryer screens included. Tower dryer screens not included.

GSI further warrants that the portable and tower dryer frame and basket, excluding all auger and auger drive components, shall be free from defects in materials for a period of time beginning on the twelfth (12<sup>th</sup>) month from the date of purchase and continuing until the sixtieth (60<sup>th</sup>) month from the date of purchase (extended warranty period). During the extended warranty period, GSI will replace the frame or basket components that prove to be defective under normal conditions of use without charge, excluding the labor, transportation, and/or shipping costs incurred in the performance of this extended warranty.

### Conditions and Limitations:

THERE ARE NO WARRANTIES THAT EXTEND BEYOND THE LIMITED WARRANTY DESCRIPTION SET FORTH ABOVE. SPECIFICALLY, GSI MAKES NO FURTHER WARRANTY OF ANY KIND, EXPRESS OR IMPLIED, INCLUDING, WITHOUT LIMITATION, WARRANTIES OF MERCHANTABILITY OR FITNESS FOR A PARTICULAR PURPOSE OR USE IN CONNECTION WITH: (I) PRODUCT MANUFACTURED OR SOLD BY GSI OR (II) ANY ADVICE, INSTRUCTION, RECOMMENDATION OR SUGGESTION PROVIDED BY AN AGENT, REPRESENTATIVE OR EMPLOYEE OF GSI REGARDING OR RELATED TO THE CONFIGURATION, INSTALLATION, LAYOUT, SUITABILITY FOR A PARTICULAR PURPOSE, OR DESIGN OF SUCH PRODUCTS.

GSI shall not be liable for any direct, indirect, incidental or consequential damages, including, without limitation, loss of anticipated profits or benefits. The sole and exclusive remedy is set forth in the Limited Warranty, which shall not exceed the amount paid for the product purchased. This warranty is not transferable and applies only to the original end-user. GSI shall have no obligation or responsibility for any representations or warranties made by or on behalf of any dealer, agent or distributor.

GSI assumes no responsibility for claims resulting from construction defects or unauthorized modifications to products which it manufactured. Modifications to products not specifically delineated in the manual accompanying the equipment at initial sale will void the Limited Warranty.

This Limited Warranty shall not extend to products or parts which have been damaged by negligent use, misuse, alteration, accident or which have been improperly/inadequately maintained. This Limited Warranty extends solely to products manufactured by GSI.

Prior to installation, the end-user has the responsibility to comply with federal, state and local codes which apply to the location and installation of products manufactured or sold by GSI.

This equipment shall be installed in accordance with the current installation codes and applicable regulations, which should be carefully followed in all cases. Authorities having jurisdiction should be consulted before installations are made.

**G S I G R O U P**



**GSI Group**  
**1004 E. Illinois St.**  
**Assumption, IL 62510-0020**  
**Phone: 1-217-226-4421**  
**Fax: 1-217-226-4420**  
**[www.gsiag.com](http://www.gsiag.com)**



**GSI is a worldwide brand of AGCO Corporation.**