

# CE Compliant Series II Bucket Elevator

Assembly Manual - Original Instructions

PNEG-681CE

Date: 04-29-14

GSI GROUP



PNEG-681CE

---

Use of the equipment information page will help you identify the equipment in the case that you need to notify the company. For this reason, this information should be filled out and kept on record.

**Equipment Information**

Model Number: \_\_\_\_\_

Serial Number: \_\_\_\_\_

RPM: \_\_\_\_\_

Head Pulley Diameter: \_\_\_\_\_

Discharge Height: \_\_\_\_\_

Horsepower: \_\_\_\_\_

**GSI Group**

1004 E. Illinois St.  
Assumption, IL. 62510  
Phone: 1-217-226-4421

Date Purchased: \_\_\_\_\_

Dealer Name and Phone Number: \_\_\_\_\_  
\_\_\_\_\_  
\_\_\_\_\_

GSI GROUP



**CE Declaration of Incorporation  
EC MACHINERY DIRECTIVE  
2006/42/EC**

1004 East Illinois Street, Assumption, IL, 62510, USA

+1 217 226 4429

**The GSI Group declares that**

**GSI Bucket Elevators**

Models

15P16/15G16; 20P16/20G16; 25P16/25G16; 30P16/30G16; 30P24/30G24; 40P24/40G24;  
50P24/50G24; 56P24/56G24; 50P30/50G30; 60P30/60G30; 70P30/70G30; 50P36/50G36;  
60P36/60G36; 70P36/70G36; 75P36/75G36; 80P36/80G36; 100P36/100G36; 80P42/80G42;  
100P42/100G42; 120P42/120G42; 140P42/140G42; 150P42/150G42; 200P42/200G42;  
140P48/140G48; 150P48/150G48; 160P48/160G48; 200P48/200G48; 250P42; 300P42; 400P42;  
250P48; 300P48; 400P48; 500P48; 600P48

**Meet the Essential Requirements of the Machinery Directive 2006/42/EC.**

1. This declaration applies only to the mechanical elements of the above machines and does not imply conformity by any other items of equipment fitted to or connected with the above machines.
2. The equipment must be operated by an electrical control system designed and installed in accordance with EN60204:2006 and EN ISO 13849:2006, including all necessary safety controls. This is the responsibility of the equipment installer.
3. The equipment above must not be put into service until the machinery into which it is to be incorporated has been declared in conformity with the provisions of all relevant Directives, nor until these components have been assembled in the manner recommended in the attached manufacturers instructions, PNEG-681CE.
4. This declaration is not valid unless attached to the manufacturers' instructions PNEG-681CE.

Signed:

Name: Frank Ward

Director Hennock International Limited

On behalf The GSI Group

Date:

---

# NOTES

## Contents

<b>Chapter 1 Introduction .....</b>	<b>6</b>
General Safety Statements .....	6
Receiving Inspection .....	6
Pre-Installation Notifications .....	6
<b>Chapter 2 Safety .....</b>	<b>7</b>
Safety Guidelines .....	7
General Safety Statement .....	8
Safety Instructions .....	9
Correct Use of the Bucket Elevator .....	12
Working at Heights .....	13
Electrical Safety .....	14
<b>Chapter 3 Safety Decals .....</b>	<b>16</b>
Decal Placement .....	18
<b>Chapter 4 Elevator Parts .....</b>	<b>19</b>
Part Identification .....	19
<b>Chapter 5 Bucket Elevator Foundation .....</b>	<b>20</b>
<b>Chapter 6 Boot Section .....</b>	<b>21</b>
Attaching Boot to Foundation .....	22
Inspection Sections .....	23
<b>Chapter 7 Trunking .....</b>	<b>24</b>
Standard Trunking .....	24
Pressure Relief Trunking .....	25
Trunking Installation .....	26
<b>Chapter 8 Lower Head Section .....</b>	<b>27</b>
Head Bonnet Section .....	27
<b>Chapter 9 Maintaining Plumbness .....</b>	<b>29</b>
<b>Chapter 10 Belting, Splicing and Buckets .....</b>	<b>30</b>
Belts .....	30
Splicing .....	30
Buckets .....	31
Belt Slack Removal .....	32
<b>Chapter 11 Drive Motor and Motor Mount .....</b>	<b>34</b>
Drive .....	34
Motor Mount Assembly .....	34
Slide Base .....	36
Torque Arm .....	37
Shaft Mount Reducer .....	38
Drive Guard .....	39
Drive Belts .....	44
<b>Chapter 12 Final Checks, Tracking, Start-Up and Maintenance .....</b>	<b>45</b>
General Final Checks .....	45
Belt Tracking .....	46
Start-Up .....	46
Maintenance .....	46
Dealing with Elevator Blockages .....	47
<b>Chapter 13 Appendix 1 - Reference Information .....</b>	<b>49</b>
<b>Chapter 14 Warranty .....</b>	<b>51</b>

## 1. Introduction

---

Thank you for choosing a GSI product. It has been designed to provide excellent performance and service for many years.

This manual covers general information about installing the GSI Bucket Elevator.

Due to the large variety of equipment features offered, this manual cannot cover every aspect of installation with this manual. This manual provides suggested and recommended methods for installing the product. GSI recommends you retain a qualified contractor to provide on-site expertise.

GSI is not responsible for the installation of this product.

## General Safety Statements

1. Our primary concern is your safety and the safety of others associated with the use of this product. All personnel responsible for installing, operating or maintaining this equipment should read and understand this manual. It is the responsibility of the owner to make this manual available to the person or persons involved with this equipment.
2. Guards and safety labels have been installed prior to leaving the manufacturing plant. These should not to be removed, altered or defaced in any way.
3. Modifications to equipment may cause extremely dangerous situations that could result in damage to the equipment as well as serious injury or death. Never modify the equipment.
4. GSI recommends that you contact the local power company to have a representative survey the installation to ensure wiring is compatible with their system and adequate power is supplied to the unit.

## Receiving Inspection

1. Carefully inspect the shipment for damage as soon as it is received and verify that the quantity of parts or packages actually received corresponds to the quantity shown on the packing slip.
2. Report any discrepancies, shortages or damages to the delivering carrier as soon as possible.
3. The manufacturer's responsibility for damage to the equipment ends when the carrier accepts the equipment for delivery. Refer to the bill of lading for more detailed information.
4. Save all paperwork and documentation furnished with any of the elevator components.

## Pre-Installation Notifications

1. GSI is the manufacturer and vendor of the elevator and is responsible only for the optional accessories also manufactured by GSI.
2. The elevator has not been designed to support other equipment such as cleaners, distributors or spouting. Separate structures must be provided for any accessory equipment.
3. This installation manual should be used for reference only.
4. The owner/user/installer of this equipment is responsible for consulting and retaining a civil or structural engineer regarding the design, construction and supervision of the entire installation, including the elevator foundation and the guying cable and/or bracing system.
5. GSI Bucket Elevators are designed to be vertically self-supporting when erected but must be supported or guyed against wind loads.

## Safety Guidelines

This manual contains information that is important for you, the owner/operator, to know and understand. This information relates to protecting **personal safety** and **preventing equipment problems**. It is the responsibility of the owner/operator to inform anyone operating or working in the area of this equipment of these safety guidelines. To help you recognize this information, we use the symbols that are defined below. Please read the manual and pay attention to these sections. Failure to read this manual and its safety instructions is a misuse of the equipment and may lead to serious injury or death.



This is the safety alert symbol. It is used to alert you to potential personal injury hazards. Obey all safety messages that follow this symbol to avoid possible injury or death.



**DANGER** indicates a hazardous situation which, if not avoided, will result in death or serious injury.



**WARNING** indicates a hazardous situation which, if not avoided, could result in death or serious injury.



**CAUTION**, used with the safety alert symbol, indicates a hazardous situation which, if not avoided, could result in minor or moderate injury.



**NOTICE** is used to address practices not related to personal injury.

## 2. Safety

---

### General Safety Statement

Our foremost concern is your safety and the safety of others associated with grain handling equipment. This manual is to help you understand safe operating procedures and some problems that may be encountered by the operator and other personnel.

As owner and/or operator, you are responsible to know what requirements, hazards, and precautions exist and inform all personnel associated with the equipment or in the area. Safety precautions may be required from the personnel. Avoid any alterations to the equipment, which may produce a very dangerous situation, where **SERIOUS INJURY** or **DEATH** may occur.

You should consider the location of the bin site relative to power line locations or electrical transmission equipment. Contact your local power company to review your installation plan or for information concerning required equipment clearance. Clearance of portable equipment that may be taken to the bin site should also be reviewed and considered. Any electrical control equipment in contact with the bin should be properly grounded and installed in accordance with National Electric Code provisions and other local or national codes.

This product is intended for the use of grain storage only. Any other use is a misuse of the product.



This product has sharp edges, which may cause serious injury. To avoid injury, handle sharp edges with caution and always use proper protective clothing and equipment.

Sidewall bundles or sheets must be stored in a safe manner. The safest method of storing sidewall bundles is laying horizontally with the arch of the sheet upward, like a dome. Sidewall sheets stored on edge must be secured so that they cannot fall over and cause injury. Use care when handling and moving sidewall bundles.

Personnel operating or working around equipment should read this manual. This manual must be delivered with equipment to its owner. Failure to read this manual and its safety instructions is a misuse of the equipment.



## Safety Instructions

Our foremost concern is your safety and the safety of others associated with this equipment. We want to keep you as a customer. This manual is to help you understand safe operating procedures and some problems that may be encountered by the operator and other personnel.

As owner and/or operator, it is your responsibility to know what requirements, hazards, and precautions exist, and to inform all personnel associated with the equipment or in the area. Safety precautions may be required from the personnel. Avoid any alterations to the equipment. Such alterations may produce a very dangerous situation where **SERIOUS INJURY** or **DEATH** may occur.

This equipment shall be installed in accordance with the current installation codes and applicable regulations, which should be carefully followed in all cases. Authorities having jurisdiction should be consulted before installations are made.

### Follow Safety Instructions

Carefully read all safety messages in this manual and safety signs on your machine. Keep signs in good condition. Replace missing or damaged safety signs. Be sure new equipment components and repair parts include the current safety signs. Replacement safety signs are available from the manufacturer.

Learn how to operate the machine and how to use controls properly. Do not let anyone operate without instruction.

Keep your machinery in proper working condition. Unauthorized modifications to the machine may impair the function and/or safety and affect machine life.

If you do not understand any part of this manual or need assistance, contact your dealer.

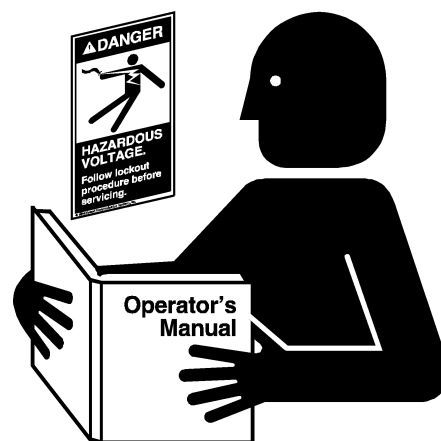

**Read and Understand Manual**

### Stay Clear of Moving Belt

Entanglement in moving belt can cause serious injury or death.

Keep all shields and covers in place at all times.

Wear close fitting clothing. Stop and lock out power source before making adjustments, cleaning, or maintaining equipment.

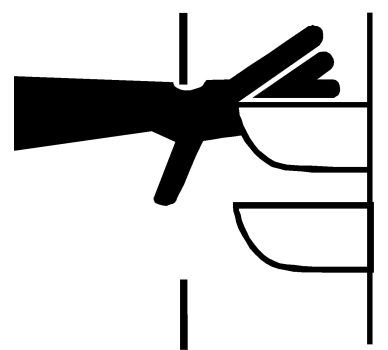

## 2. Safety

### Operate Motor Properly

In an emergency, shut down the power source.

Turn OFF and lock out all power sources before performing any maintenance.

Do not operate electric motor equipped units until motors are properly grounded.

Disconnect power on electrical driven units before resetting motor overloads.

Do not repetitively stop and start the drive in order to free a plugged condition. Jogging the drive in this manner can damage the equipment and/or drive components.

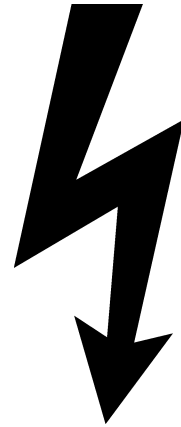

**Electric Shock Hazard**

### Practice Safe Maintenance

Understand service procedures before doing work. Keep area clean and dry.

Never lubricate, service, or adjust machine while it is in operation. Keep hands, feet, and clothing away from rotating parts.

Keep all parts in good condition and properly installed. Fix damage immediately. Replace worn or broken parts. Remove any built-up grease, oil, and debris.



**Maintain Equipment and Work Area**

### Remove Paint Before Welding or Heating

Avoid potentially toxic fumes and dust.

Hazardous fumes can be generated when paint is heated by welding, soldering, or using a torch.

Do all work outside or in a well-ventilated area.

Dispose of paint and solvent properly.

Remove paint before welding or heating:

- If you sand or grind paint, avoid breathing the dust. Wear an approved respirator.
- If you use solvent or paint stripper, remove stripper with soap and water before welding. Remove solvent or stripper containers and other flammable material from area. Allow fumes to disperse at least 15 minutes before welding or heating.

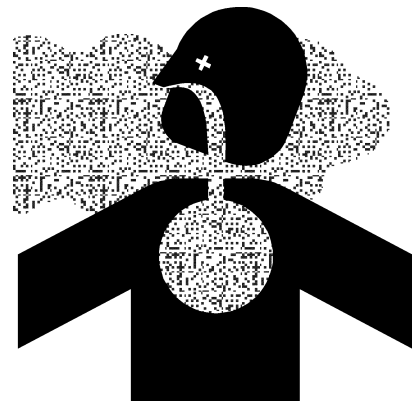

**Breathing Hazard**

**Prepare for Emergencies**

Be prepared if fire starts.

Keep a first aid kit and fire extinguisher handy.

Keep emergency numbers for doctors, ambulance service, hospital, and fire department near your telephone.

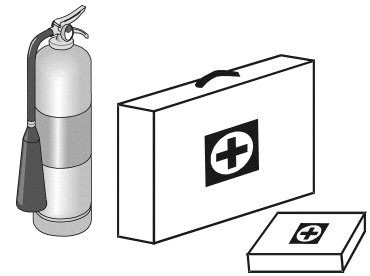

**Keep Emergency Equipment Quickly Accessible**

**Wear Protective Clothing**

Wear close-fitting clothing and safety equipment appropriate to the job.

Remove all jewelry.

Tie long hair up and back.

Wear safety glasses at all times to protect eyes from debris.

Wear gloves to protect your hands from sharp edges on plastic or steel parts.

Wear steel-toed boots to help protect your feet from falling debris. Tuck in any loose or dangling shoestrings.

A respirator may be needed to prevent breathing potentially toxic fumes and dust.

Wear a hard hat to help protect your head.

Wear appropriate fall protection equipment when working at elevations greater than six feet (6').

**Eye Protection**

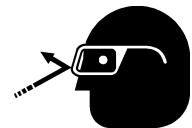

**Gloves**



**Steel-Toed Boots**



**Respirator**



**Hard Hat**



**Fall Protection**



### Correct Use of the Bucket Elevator

1. These elevators are designed solely for conveying whole agricultural grain and seeds. Use for any other material is a misuse and could result in serious injury and equipment damage.
2. Never operate the Bucket Elevator without completely enclosing the inlet or outlet, making all moving parts in-accessible to any person. (See Figure 2A.)

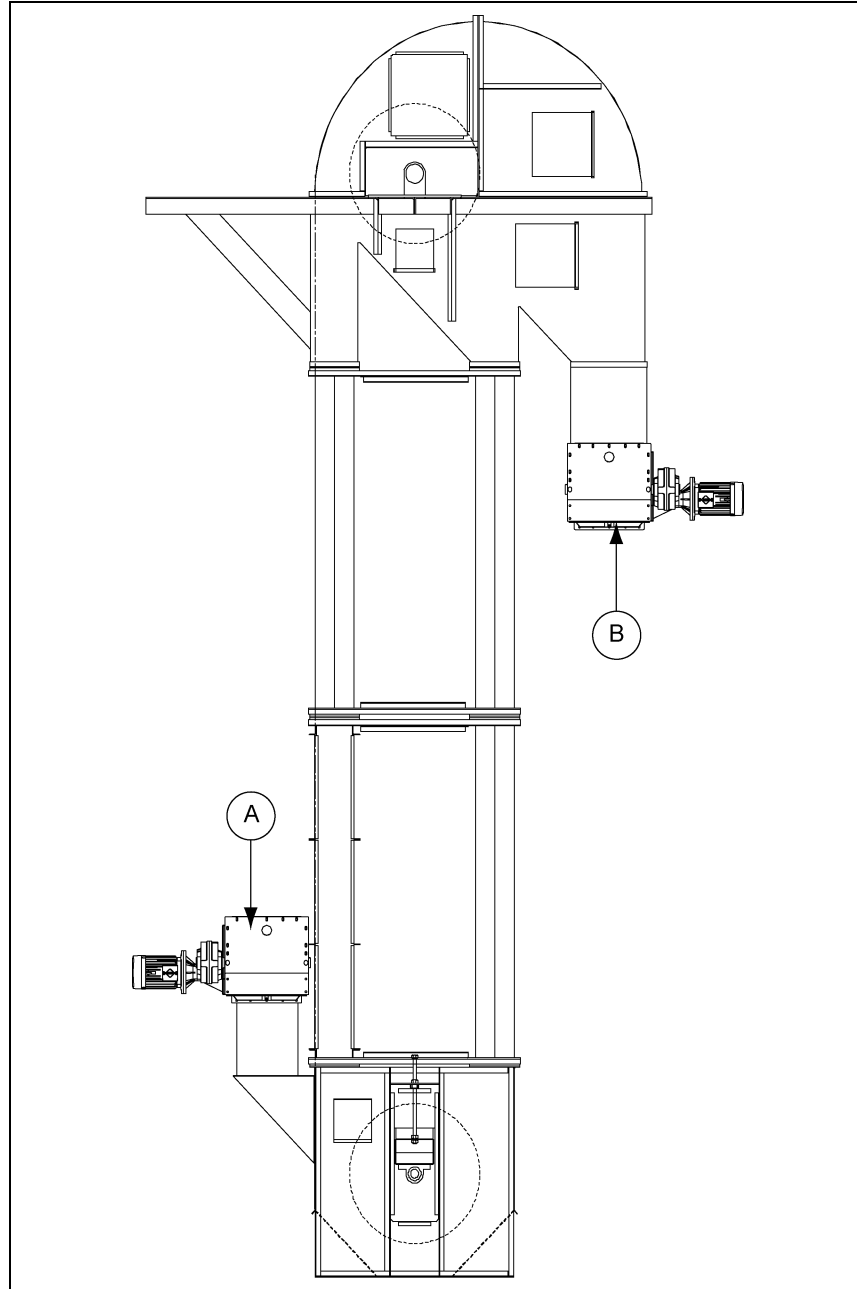

**Figure 2A** Example of Enclosed Inlet and Outlet

Ref #	Description
A	Example Enclosed Inlet Conveyor Feeding Elevator
B	Example Enclosed Outlet Feeding Conveyor

## Correct Use of the Bucket Elevator (Continued)

3. Never operate with guards removed or inspection covers open.
4. Never open or work on the moving parts of the Bucket Elevator unless:
  - a. It has been run completely empty of grain. (A loaded elevator might result in unexpected movement of the belt and buckets even when locked out.)
  - b. It is locked out and tagged out at the main electrical isolator.
  - c. All equipment working with the elevator are also locked out and tagged out.
5. The elevator must be installed vertical in all directions and must not be used at any other angle.
6. Do not fix a hoist or other lifting equipment to the Bucket Elevator, nor to the ladders or platforms attached to the elevator.
7. Ladders and platforms attached to the elevator are for personnel access only and must not be used to carry or support heavy pieces of equipment.
8. Do not exceed the maximum ladder and platform load, noted on the warning decal (225 kg).
9. Never alter or adjust the elevator from its original specification.
10. Always lock out and tag the electrical power to the elevator before working on it.
11. Do not use the elevator in an enclosed, potentially explosive area.

## Working at Heights

The equipment has been designed to operate primarily at ground level, at some stages during the life cycle it will be necessary to work at heights. For this reason the equipment has been provided with access ladders and platforms, to minimize the risk to health and safety. In addition attention should be paid to the following safety requirements.

1. The ladders, platforms and walkways are for use by competent and trained personnel only. NEVER allow children or members of the general public to gain access to the equipment, its ladders or access platforms.
2. Where the equipment is sited in an unsecured location, access must be restricted by use of security fencing and lockable gates.
3. Lower sections of ladders on the equipment should be fitted with a lockable safety gate, to prevent unauthorized access.
4. The equipment should be OFF and all power LOCKED OFF before work on or in the equipment. Ensure the power isolator is OFF and LOCKED and TAGGED to prevent inadvertent re-start. This must include all equipment attached to the elevator on which you are working. *(See Figure 2B on Page 14.)*

### Working at Heights (Continued)



Figure 2B

5. NEVER attach lifting equipment to ladders or platforms.
6. When working on the equipment, NEVER go outside the safety rails provided.
7. Do not work at heights during high winds, heavy rain, snow, ice or storm.

The majority of routine service can be carried out from the service platforms provided. In the rare event that access is required outside these structures additional access and safety equipment may be required, such as powered access lift platforms and safety harness. Such work must only be carried out by specialist technicians trained and qualified in working at heights and only after a complete risk assessment has been carried out and safe working methods established.

### Electrical Safety

It is recommended that the electrical system to the equipment include, at minimum, the following:

1. Main power supply protected by suitable fuses or over current circuit breaker.
2. Main electrical disconnect lock out switch which can be locked.
  - a. To disconnect all electrical power to the equipment and other associated equipment.
3. Service disconnect which can be locked.
  - a. Installed immediately adjacent to each motor.
  - b. Wired to disconnect all electrical power to the equipment motor.
  - c. May also be wired to stop other equipment if required for safety during maintenance and servicing.

## Electrical Safety (Continued)

4. Emergency stops.
  - a. Wired to stop the equipment motor (and any other associated equipment) immediately when pressed.
  - b. Must remain engaged until manually disengaged.
  - c. The equipment should not be able to re-start immediately the emergency stop is re-set.
5. The electrical supply must include a properly designed protective earth system (PE), with connection to all exposed conductive parts.
6. All motors must be connected to protective earth at the terminal provided.
7. The control system to include.
  - a. Short circuit protection.
  - b. Start/stop controls (labelled 1 and 0 respectively).
  - c. Controls designed to default to OFF after a power interruption. (Ex: Self maintained relay.)
  - d. The equipment should not be able to immediately re-start following re-establishment of power or following the re-set of an emergency stop or other safety interlock.
8. Motor circuits must include motor over current protection, wired to stop the motor when the current exceeds the motor full load current, stated in the motor rating plate.
9. It is also recommended that the electrical supply is protected by earth leakage protection, such as Residual Current Device (RCD) or Residual Current Circuit Breaker (RCCB), to provide additional automatic disconnection from the power in the event of a fault.

All electrical installation and design must be carried out by a qualified electrical engineer, in accordance with EU Directives and standards and in accordance with local laws and codes. Ex: IEC 60204-1:2006.

### 3. Safety Decals

Safety decals have been affixed to the equipment to warn of danger to persons and of possible equipment damage. These decals must never be removed, tampered with, painted over or obscured in any way. If labels are damaged or become unreadable, replacement labels are available from the manufacturer.

If a decal is damaged or is missing contact:





#### GSI Decals

1004 E. Illinois St.  
Assumption, IL. 62510  
Phone: 1-217-226-4421

#### International Decals

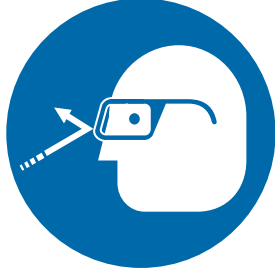
International, translated versions of the decals fitted to the equipment are available as part of the Language Pack that was supplied with the product. If you need further copies or a different language, please contact GSI or your dealer.

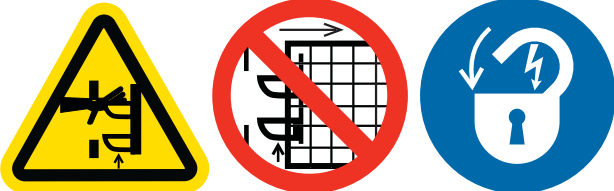
The international decals have been designed to be placed directly over the USA standard versions. Normally these will be factory fitted, but if you need to change them, please refer to the decal cross reference sheet, provided with the Language Pack and the decal locations given in the user's manual.

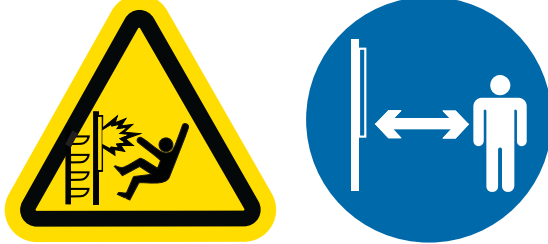
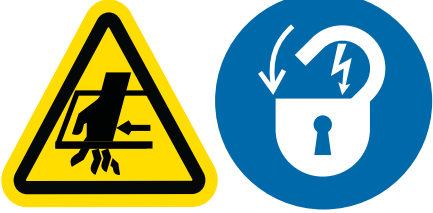
 <p>GSI Group 217-226-4421 <span style="float: right;">DC-2248</span></p>	 <p>GSI Group 217-226-4421 <span style="float: right;">DC-2250</span></p>
<p><b>A DC-2248</b></p>	<p><b>D DC-2250</b></p>
 <p>GSI Group 217-226-4421 <span style="float: right;">DC-2249</span></p>	 <p>GSI Group Inc. 217-226-4421 <span style="float: right;">DC-2238</span></p>
<p><b>B DC-2249</b></p>	<p><b>E DC-2238</b></p>
 <p>GSI Group 217-226-4421 <span style="float: right;">DC-2251</span></p>	<p>Automatic Machinery Automatické stroje a zařízení Automatikus Machinery автоматичні машини automatische machines Автоматические машины автоматичні машини Automatiska Maskinas Automatinis Machinery machines automatiques Maquinaria automática macchine automatiche automatiska maskiner Otomatik Makina Máquinas automáticas Aparate Automaattinen Machinery</p>  <p>GSI Group 217-226-4421 <span style="float: right;">DC-2252</span></p>
<p><b>C DC-2251</b></p>	<p><b>F DC-2252</b></p>





GSI Group 217-226-4421

DC-2213

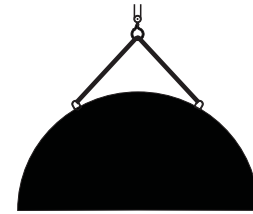

GSI Group 217-226-4421

DC-2253

G DC-2213

H DC-2253

The GSI Group  
1004 E. Illinois St.  
Assumption, IL. 62510  
USA



<b>Model</b>	150P48 - 105
<b>Height to discharge</b>	105'/32.01m
<b>Pulley diameter</b>	48"/1219 mm
<b>Pulley speed</b>	56 RPM
<b>Belt speed</b>	720 fpm/3.66 m/s
<b>Maximum capacity</b>	18750 cfh/531 m <sup>3</sup> /h
<b>Bucket size</b>	18 x 8"
<b>Bucket spacing</b>	9-1/2"/241 mm
<b>SN</b>	123456789
<b>Date</b>	01 May 2012
	30 hp/22.5 kW
	3 ~
	240 V (AC)
	73 A
	50 Hz

Rating plate

Decal Placement

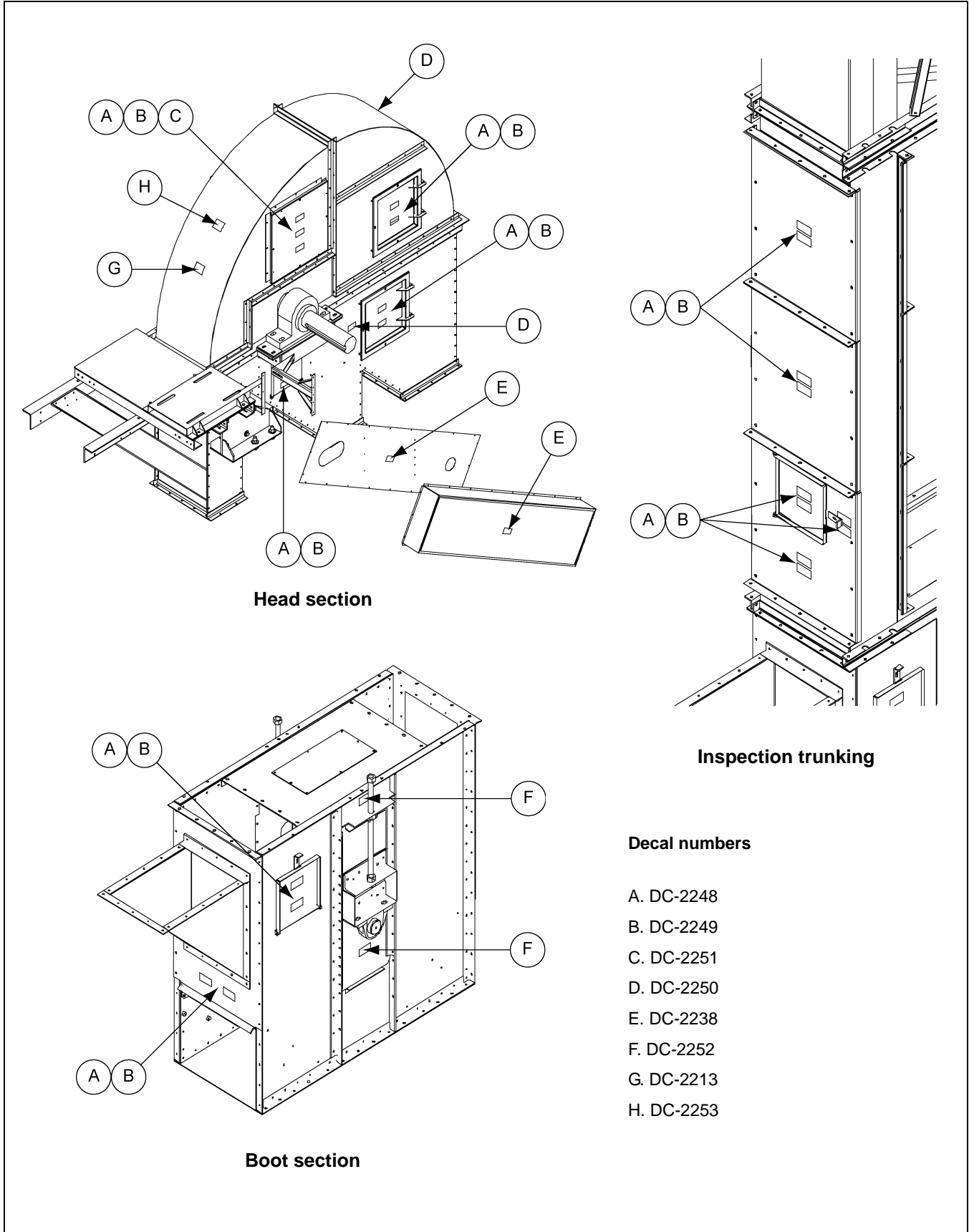

## Part Identification

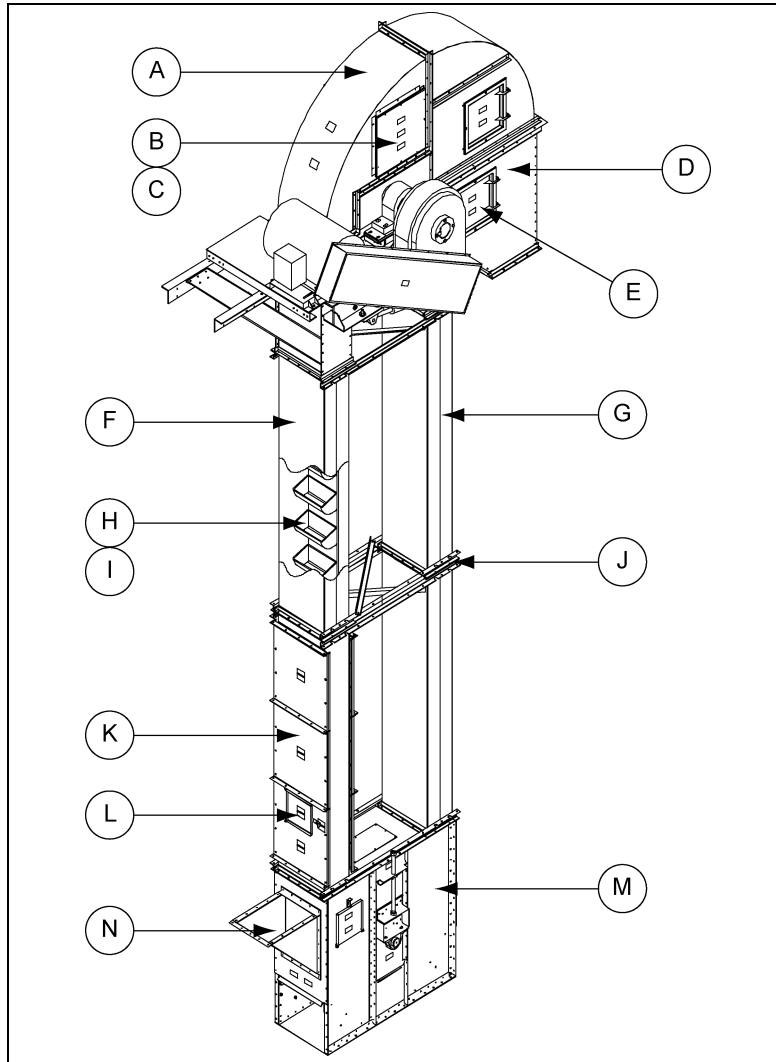

Figure 4A

Ref #	Description
A	Bonnet
B	Pressure Relief Panel (One Each Side)
C	Head Pulley
D	Lower Head Section
E	Inspection Door
F	Up-Leg Trunking
G	Down-Leg Trunking
H	Belt
I	Buckets
J	Tie Angles
K	Inspection Section
L	Inspection Door
M	Boot Section
N	Upside Hopper (Downside Hopper Optional)

## 5. Bucket Elevator Foundation

---

1. The Bucket Elevator foundation must be designed by a qualified civil engineer and installed by a qualified contractor.
2. Always consider the additional weight of live loads, dead loads, wind loads and soil bearing loads.
3. Always provide for proper moisture run-off on the top of the foundation.

Boot sections are pre-assembled at the factory. Boot inlet hoppers are typically shipped separately.

1. Before installing boot on foundation, examine boot for damage or loose hardware. Do not attempt to install if parts are damaged.
2. Proper position of boot is critical for successful installation. Boot inlet section can be installed as an up-leg or a down-leg inlet.
3. Identify the up and down side of boot. (See Figure 6A.)

**NOTE:** The up-leg inlet position is approximately six inches (6") higher than the down-leg side.

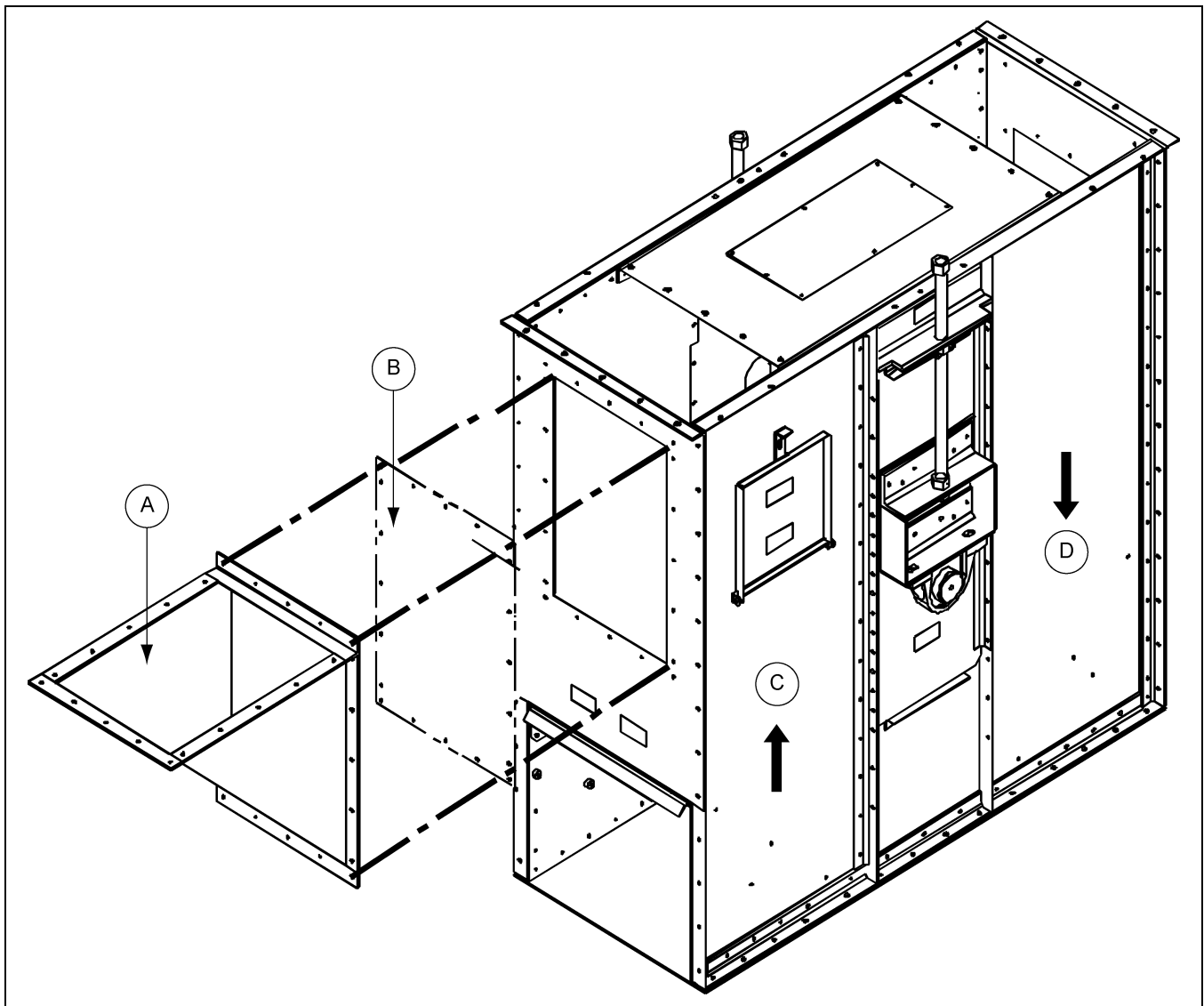

**Figure 6A** Boot Section

Ref #	Description
A	Inlet Hopper (On Up Side)
B	Inlet Blank Plate (Standard)
C	Up Side
D	Down Side

### Attaching Boot to Foundation

1. Remove the nuts and inlet blank plates to attach boot inlet hopper.
2. Anchor and level boot. Boot must be level and plumb. There are a variety of ways to accomplish this. GSI recommends that you shim to the perimeter, secure with hold-downs and grout the base.
3. Set boot in place.
4. Level in all directions prior to anchoring.
5. Use anchor bolts and mounting brackets (not supplied) to secure boot to foundation.
6. Check boot levelness and plumbness periodically throughout the installation process to ensure proper elevator erection.

## Inspection Sections

The inspection section of the GSI Bucket Elevator has been designed for easy installation and maintenance.

1. The removable panels can be installed in any order, to allow for the installation of inspection doors at any preferred locations.

**NOTE:** *Typical installations often place the inspection section directly above the boot on the up-leg side as the first trunking section.*

**NOTE:** *Installation will vary and depend on the configuration and application.*

**NOTE:** *Along with the inspection section, you will receive installation hardware and two (2) tie angles. Units containing 42" diameter pulleys and larger, will include a cross tie on the legs, which will be included. (See Figure 6B below and Figure 7A on Page 24.)*

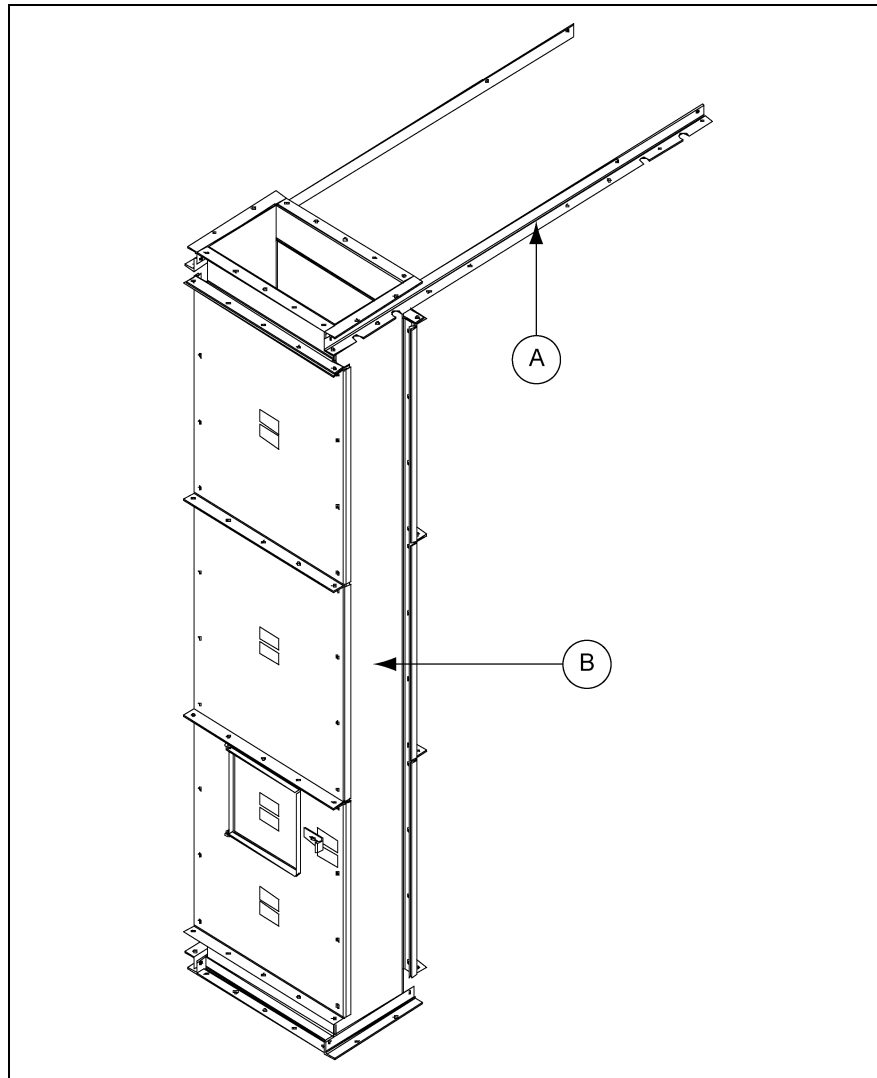

**Figure 6B** *Inspection Section*

Ref #	Description
A	Tie Angle
B	Inspection Section

## 7. Trunking

### Standard Trunking

Standard trunking sections may be fabricated from painted or galvanized steel.

**IMPORTANT:** Galvanized steel trunking **MUST** have the riveted (huck bolted) seams located to the inside, facing each other on the up-leg and the down-leg. (See Figure 7B.)

**NOTE:** Trunking sections come complete with appropriate hardware and two (2) tie angles. Units containing 42" diameter or larger pulleys have a cross tie angle included for additional support.

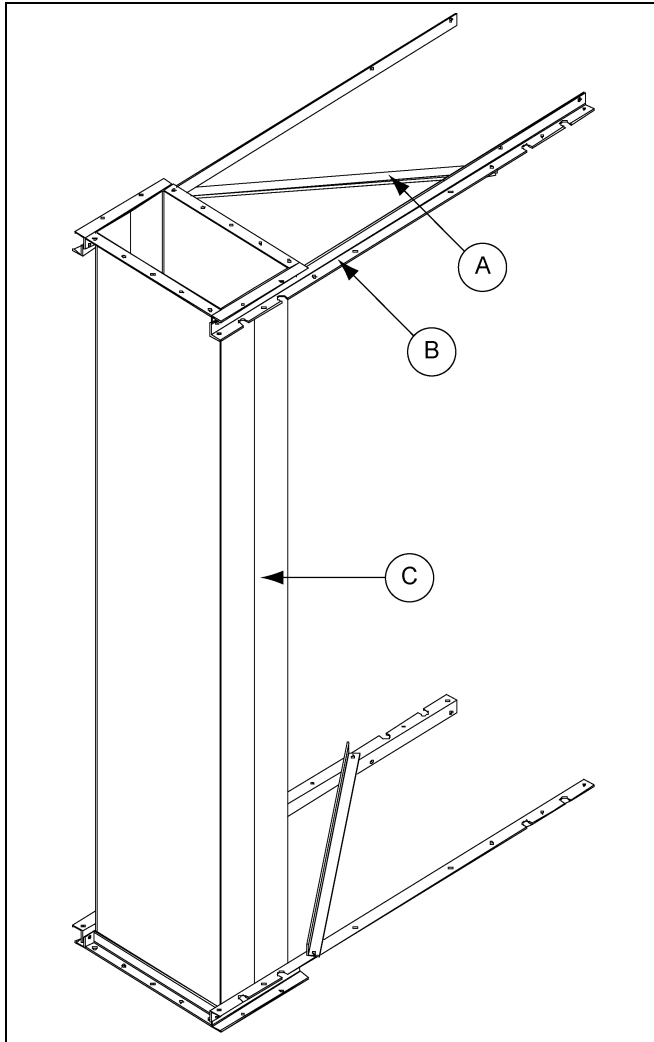

Figure 7A Painted Trunking

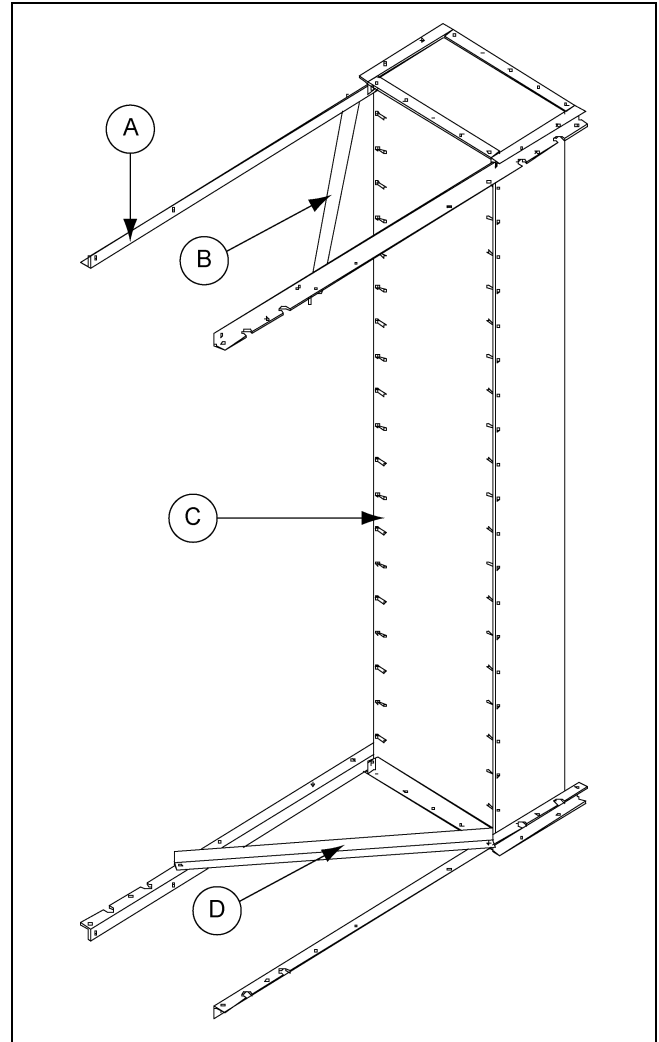

Figure 7B Galvanized Trunking

Ref #	Description
A	Cross Tie (Only 42" or larger diameter pulleys only.)
B	Tie Angle (Additional set shown for orientation.)
C	Painted Trunking (10' Section shown.)

Ref #	Description
A	Tie Angle (Additional set shown for orientation.)
B	Cross Tie
C	Note Orientation of Hucked Trunking (Galvanized only.)
D	Cross Tie (Only 42" or larger diameter pulleys only.)



## Pressure Relief Trunking

Pressure relief trunking is standard trunking that has been modified to include two (2) panels specifically designed for pressure relief.

**NOTE:** *This unit requires special attention to the relief panel. This area must be inspected for damage to the panel, frame and particularly the hardware. DO NOT INSTALL TRUNKING IF THERE IS ANY APPARENT DAMAGE OR DEFECT.*

1. These panels will be located on the short sides of the trunking directly opposite of each other and centered on ten foot (10') sections of trunking.
2. Two (2) tie angles are included with the mounting hardware.
3. Systems utilizing 42" diameter and larger pulleys require the installation of a cross tie located on the legs. (See Figure 7C.)



**Remove all shipping bolts in the pressure relief panels prior to operating any Bucket Elevator.**

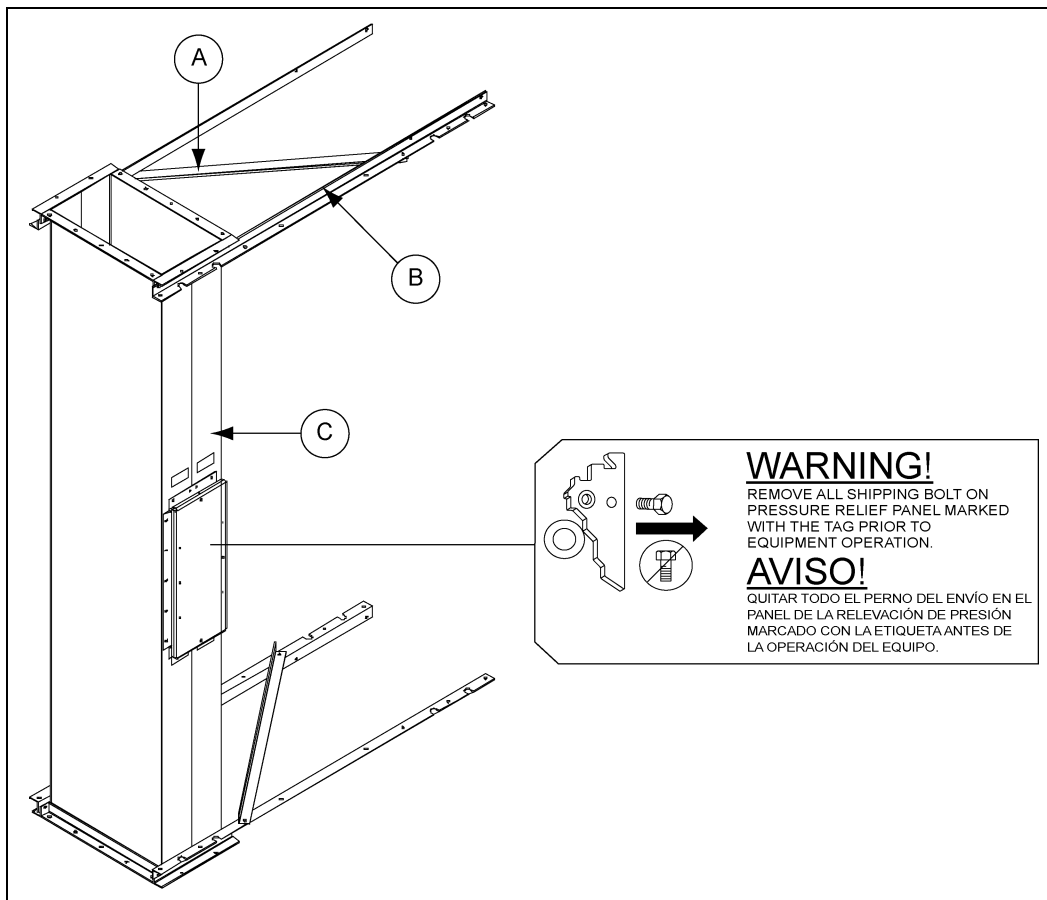

**Figure 7C** Pressure Relief Trunking

Ref #	Description
A	Cross Tie (Only 42" or larger diameter pulleys only.)
B	Tie Angle (Additional set shown for orientation.)
C	Pressure Trunking (10' Section shown.)

## 7. Trunking

### Trunking Installation

Prior to any trunking installation, inspect for damage to equipment. Immediately repair or replace defective item(s).

**NOTE:** Always assemble trunking sections on a level surface.

1. Section together to make double trunking.
2. Attach tie angle to single trunking as shown in [Figure 7D](#). (If 42" diameter or larger install cross tie angle.)
3. Multiple sections can be ground assembled.
4. Make sure sections are assembled straight, without twist.
5. Caulk all mating companion angle surfaces to ensure water and dust resistance.

**NOTE:** Do NOT assemble more than thirty (30) linear feet at any time.

**NOTE:** It is important to maintain plumb and square trunking in all directions.

- Guy and plumb trunking in all directions after installing each section.
- Check levels through legging installation process.
- Check all connecting hardware is secure after each installation.

**NOTE:** Attachment bolt holes in the tie angles are intentionally tight for the 1/2" diameter bolts. This helps ensure more precise plumbing of the trunking. Never drill these holes out for easier installation.



**NEVER drill out attachment holes for easier installation of the 1/2" diameter bolts. If bolts are hindered going through hole, thread bolts through to reduce chances of damaging threads.**

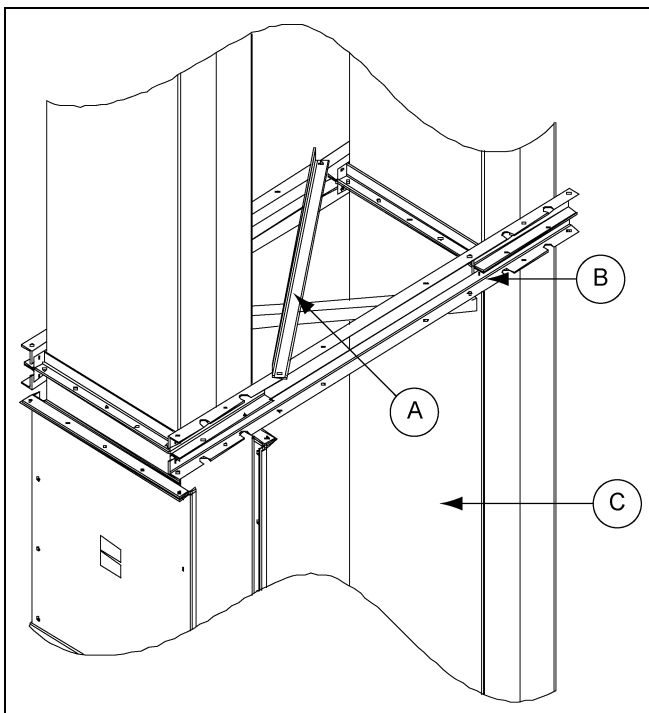

Figure 7D Trunking Joint

Ref #	Description
A	Cross Tie (Only 42" or larger diameter pulleys only.)
B	Tie Angle
C	Typical Trunking Joint

The Bucket Elevator lower head section is primarily assembled at the factory.

1. The installation hardware used to attach the head section to the trunking system is included with the shipment.
2. The drive is shipped separately from the lower head section.
3. Inspect all parts for damage and to ensure that all hardware is secure prior to proceeding with installation. (See Figure 8A.)

### Head Bonnet Section

The bonnet has been designed in two-piece construction to allow the front (discharge) side to slide forward and clamp in place for maintenance to the belt, buckets, pulley, etc.

1. The rear (up-leg) side bonnet on 30" Bucket Elevators and larger sizes includes factory installed pressure relief panels. These panels should be carefully inspected for damage including screws and washers.
2. Pressure relief vent door should not be altered in any way, except to remove shipping bolts.
3. Motor mount and torque arm must be adjusted to fit the drive package per supplied detail.
4. Hardware used to attach bonnet section to head section is included. (See Figure 8B on Page 28.)



**Use bonnet section 'U-lugs' to lift ONLY the bonnet section.**



**NEVER lift or lower the bonnet section together with the lower head section.**



**Remove all shipping bolts in the pressure relief panels prior to operating any Bucket Elevator.**

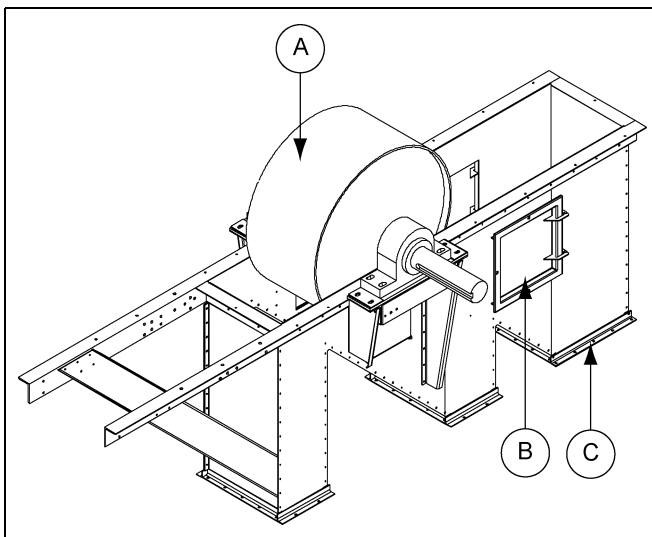

**Figure 8A** Lower Head Section

Ref #	Description
A	Pulley
B	Inspection door
C	Discharge

# Head Bonnet Section (Continued)

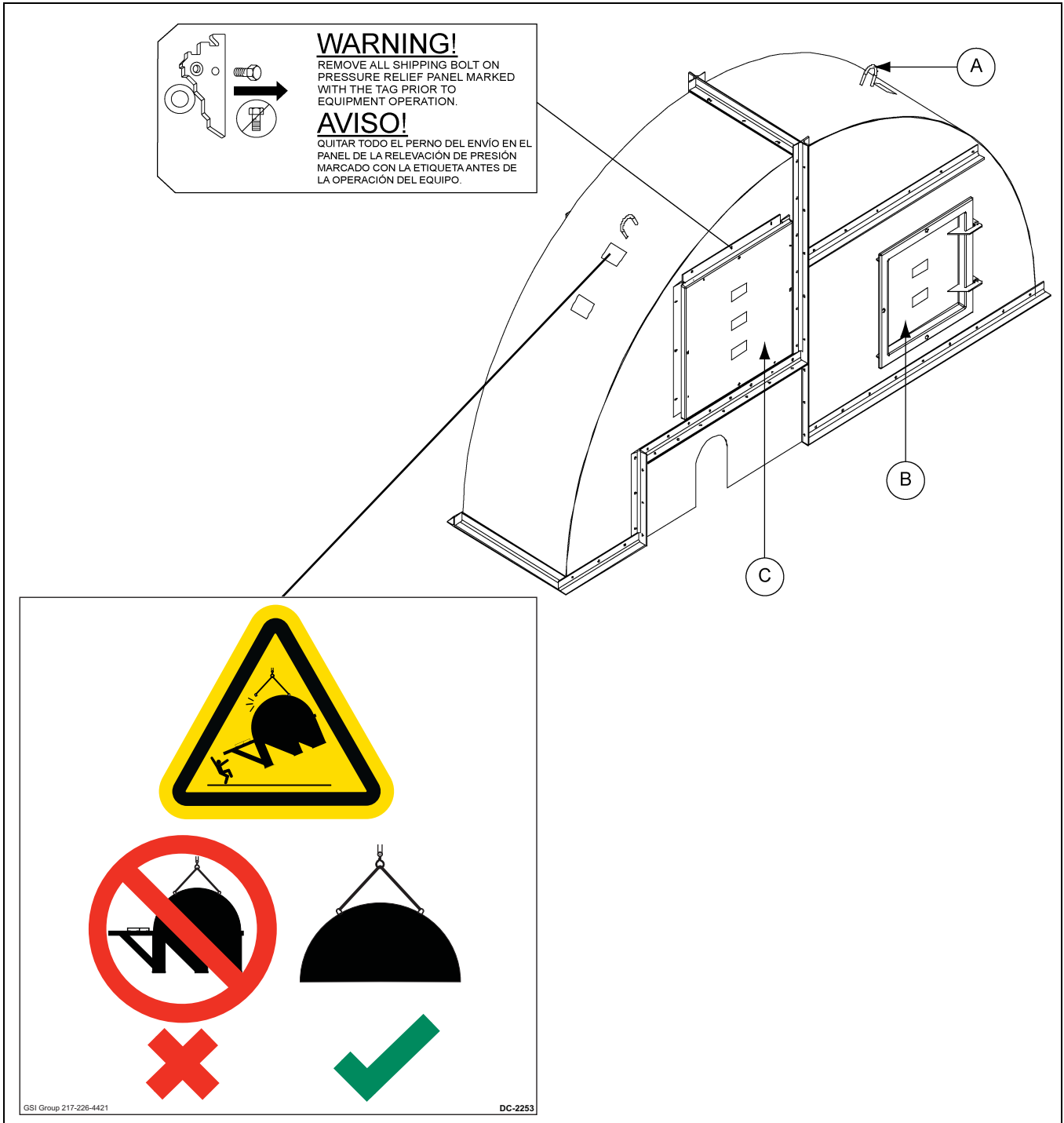
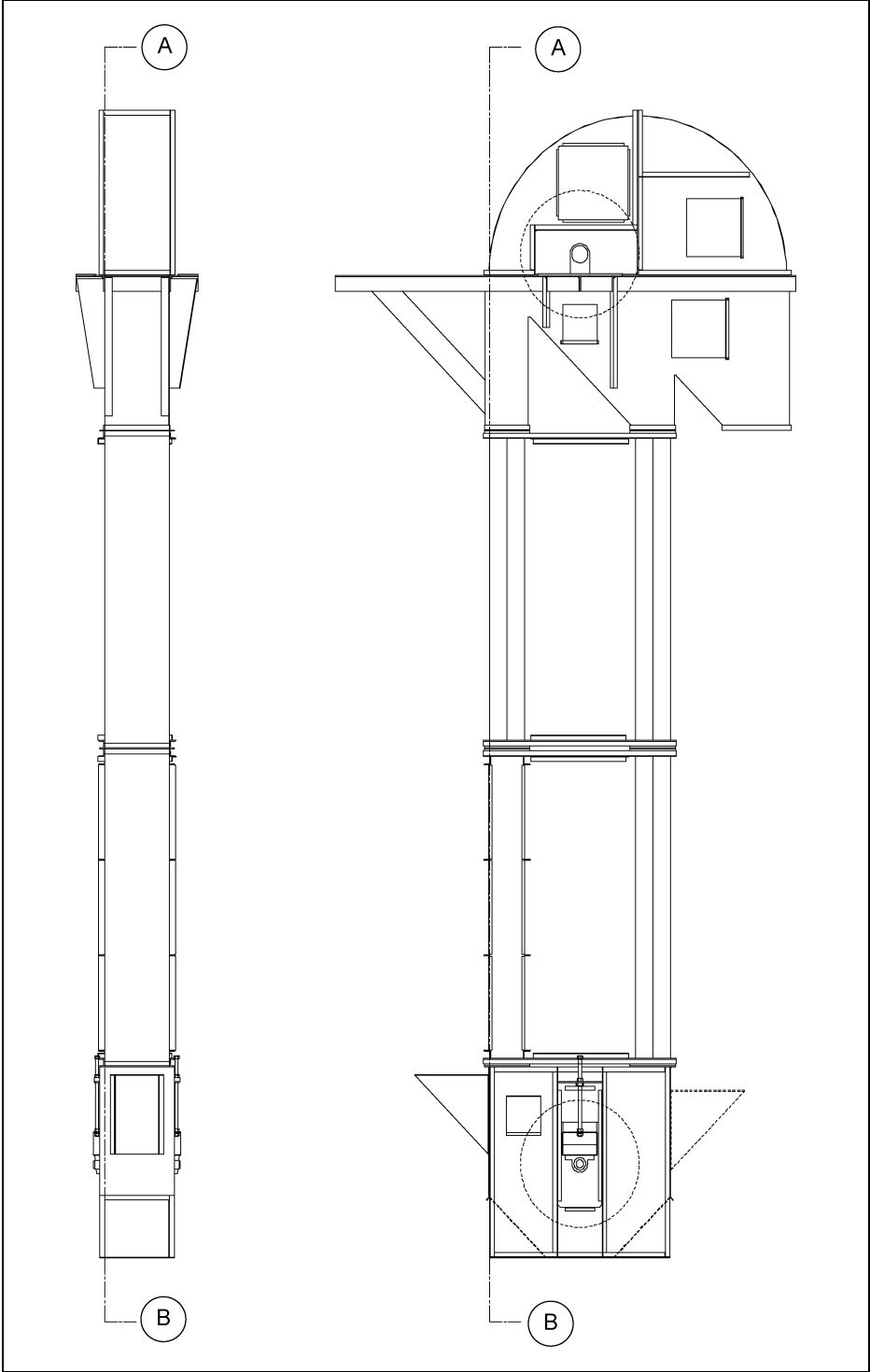

Figure 8B Head Bonnet

Ref #	Description
A	U-Lug
B	Inspection Door
C	Pressure Relief Panel

# 9. Maintaining Plumbness

To ensure proper Bucket Elevator plumbness, set up two (2) transits, one in each direction. Refer to [Figure 9A](#) for proper tolerance in elevator erection.



**Figure 9A Plumbing Tolerance**

Ref #	Description
A	Bucket Elevator to be Plumb Top to Bottom within $\pm 1/2"$ .
B	Trunk Section Casing

## 10. Belting, Splicing and Buckets

### Belts

The belt for the elevator leg has been specifically chosen based on leg height, grain, weight, pulley diameter, etc.

The belt has been pre-punched to accommodate special buckets with specific spacing.

Installing the belt can be accomplished several different ways. GSI recommends the following:

1. Prior to installing the belt, raise the boot pulley to its upper most point to allow for proper tensioning.
2. On shorter installations, consider assembling the buckets to the belt before installing the belt. While this may be less time consuming, the additional weight of the buckets and connecting hardware may make the belt more difficult to handle.
3. Feed belt up through the inspection section, over the head pulley, through the down-leg, around the boot pulley and back up to the splice.



***To prevent the belt from rolling over the top, anchor the upper end securely.***

### Splicing

After connecting the ends of the belt together, a winching device such as a come-a-long may be required.

GSI recommends splicing the belt by overlapping the belts or by using the bar splice method.

1. When overlap splicing, draw a 5' minimum of the belt coming up from the bottom of the boot over belt hanging down from head. *(See Figure 10A on Page 31.)*
2. An alternative method, the bar splice (not included) is accomplished by turning the ends of the belt out and affixing the manufactured bar splice components per the manufacturer's recommendations.

**NOTE:** *Lacing and other specific types of belt splicing are NOT recommended.*

## Splicing (Continued)

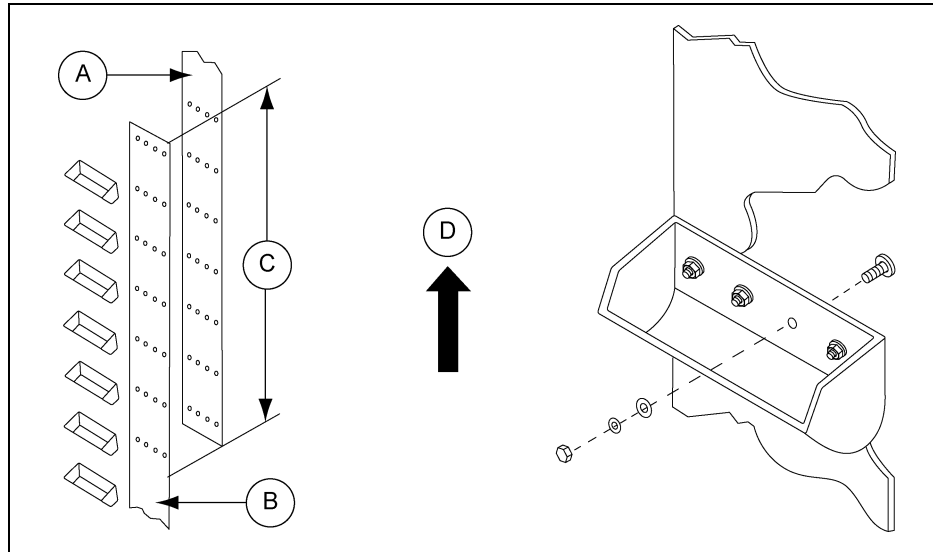

Figure 10A Belt Splicing

Ref #	Description
A	Belting Going Down from Head
B	Belting Going Up from Boot
C	5' Minimum
D	Direction of Belt Travel

## Buckets

Buckets are attached to belting using elevator bolts pushed through the belting back side, through the elevator bucket, a flat (fender) washer, a lock washer and a nut.

1. Secure bucket by tightening nut to slightly indent belt back with bolt head.
2. Remember to leave buckets off near the splice area, if installing buckets prior to belt installation.  
(See Figure 10A.)



**DO NOT OVER TIGHTEN BOLTS.**

Torque requirements are as follows:

- 5.7 N-M (50" pounds) for 1/4" bolts
- 11.0 N-M (96" pounds) for 5/16" bolts
- 20.5 N-M (180" pounds) for 3/8" bolts



**Over tightening can lead to breakage.**

3. ALWAYS re-check bolts for correct torque after initial start-up and periodically thereafter.

## 10. Belting, Splicing and Buckets

---

### Belt Slack Removal

Remove any slack in belt after splice connection by lowering boot pulley. It is important that the boot pulley and shaft are checked and maintained to be horizontally level.

### Manual Screw Take-Ups

1. Turn the take-up screws on each side of the boot to control the boot pulley position.
2. After each adjustment, ALWAYS lock each take-up screw in position with the lock nut provided.

### Gravity Take-Ups

Weight provides the tensioning method for gravity take-up.

**NOTE:** *The weight box may not require any additional weight because the weight of the belt, cups, weight box assembly and boot pulley assembly provide adequate tensioning in the belt to eliminate slippage at the head pulley.*

If additional weight is needed:

1. Add weights (not included) - Do not use increments of greater than 45 kg (100 pounds).
2. Equally distribute weight from side to side for proper belt tracking.
3. Use the bearing plate adjustment screws to level the boot pulley after any needed weight is added.
4. Loosen the bolts attaching the channels of the weight frame assembly to the bearing plate assembly before adjusting the bearing screws.
5. After adjustments have been made, re-tighten bolts and snug the bearing plate adjustment screw lock nuts. *(See Figure 10B on Page 33.)*

**NOTE:** *Lowering the bearing plate which the belt is tracking towards on the boot pulley should cause the belt to track back towards the center of the pulley. Inversely, raising the bearing plate which the belt is tracking away from will also center the belt.*



### Belt Slack Removal (Continued)

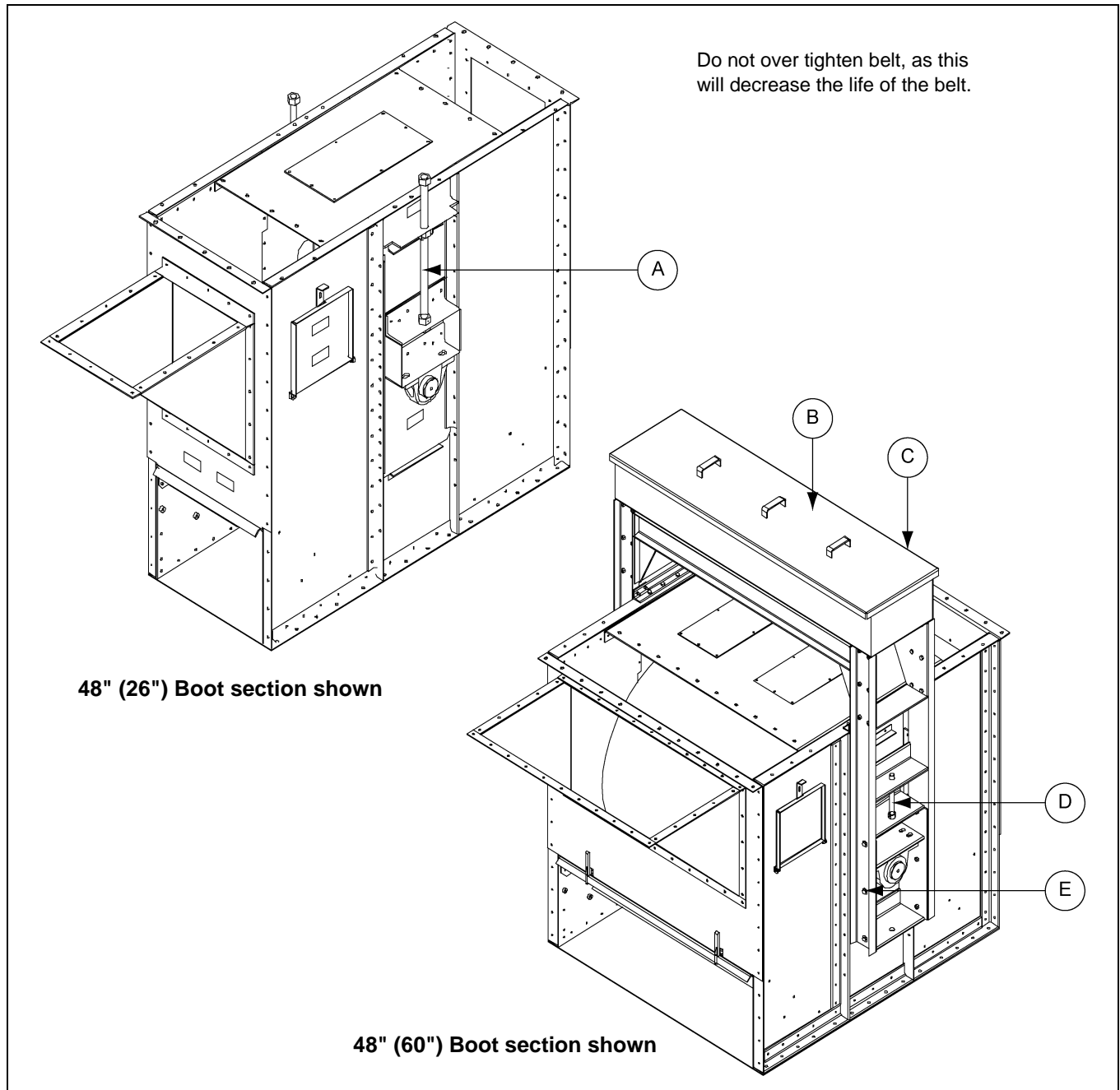

Figure 10B Take-Ups

Ref #	Description
A	Manual Take-Up Screw
B	Gravity Take-Up Weight Box
C	Gravity Take-Up Assembly
D	Bearing Plate Screw
E	Bearing Plate Adjusting Bolt

## 11. Drive Motor and Motor Mount

---

### Drive

The following assembly instructions are for standard drives as purchased with the elevator. The standard drive is designed using the Dodge Torque Arm II shaft mount reducer. Details for this application are included in the Appendix section [on Page 49](#).

If you purchased a special drive or drive components from another source, refer to manuals supplied with these materials.

1. The drive assembly is designed so that the same components fit a left or right hand drive application.
2. If facing the head side, the reducer is between you and the head and the head discharge is on the right hand side of you, then you have a right hand drive application.
3. If the head discharge is on the left side of you, then you have a left hand drive application.

The [Figure 11A and Figure 11B on Page 35](#) shown for a right hand application.

### Motor Mount Assembly

1. Locate the side of the motor mount which has two (2) decals affixed. ([See Figure 11A on Page 35.](#)) One decal will have “L.H.” for left hand and one will have “R.H.” for right hand.
2. Place the motor mount with decals facing away from the pulley towards the end of the head bearing angles.
3. Note the horsepower, class rating and drive application side on the decals. Follow the indication line next to those numbers to where it points down to the bottom of the motor mount.
4. Slide the motor mount in or out while keeping the decal correctly aligned with the outside toe of the head bearing angle. ([See Figure 11B on Page 35.](#)) This will align the holes in the head bearing angles to the proper holes in the motor mount assembly.
5. Using the proper hardware, bolt the motor mount down to the head bearing angles. ([See Figure 11A on Page 35.](#))

## Motor Mount Assembly (Continued)

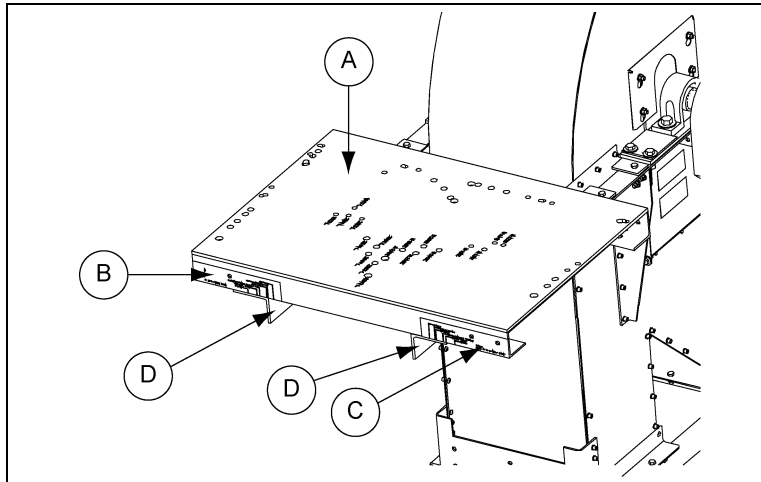

Figure 11A Motor Mount Plate

Ref #	Description
A	Motor Mount
B	Left Hand Decal
C	Right Hand Decal
D	Head Bearing Angles

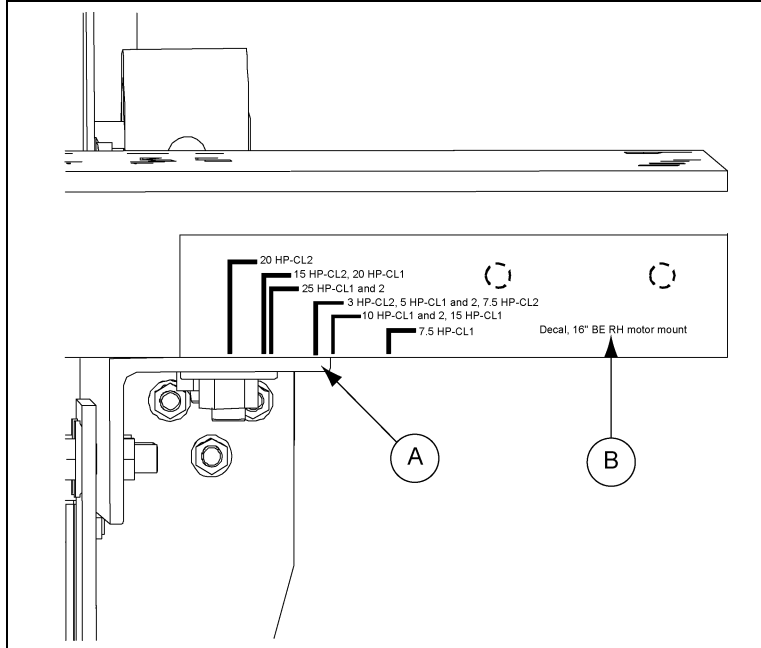

Figure 11B Right Hand Motor Placement Decals

Ref #	Description
A	Toe of Head Bearing Angle
B	Decal

## 11. Drive Motor and Motor Mount

### Slide Base

1. Place the motor slide base upon top of the motor mount, with respect to the drive application side.
2. Place the motor onto the motor slide base and position the motor as close as possible toward the pulley.

**NOTE:** The slide base will fit in only one set of holes. (See Figure 11C.)

3. Position the tensioning bolt so that tightening pulls the motor AWAY from the pulley.
4. Using the proper hardware, bolt the slide base to the motor mount.

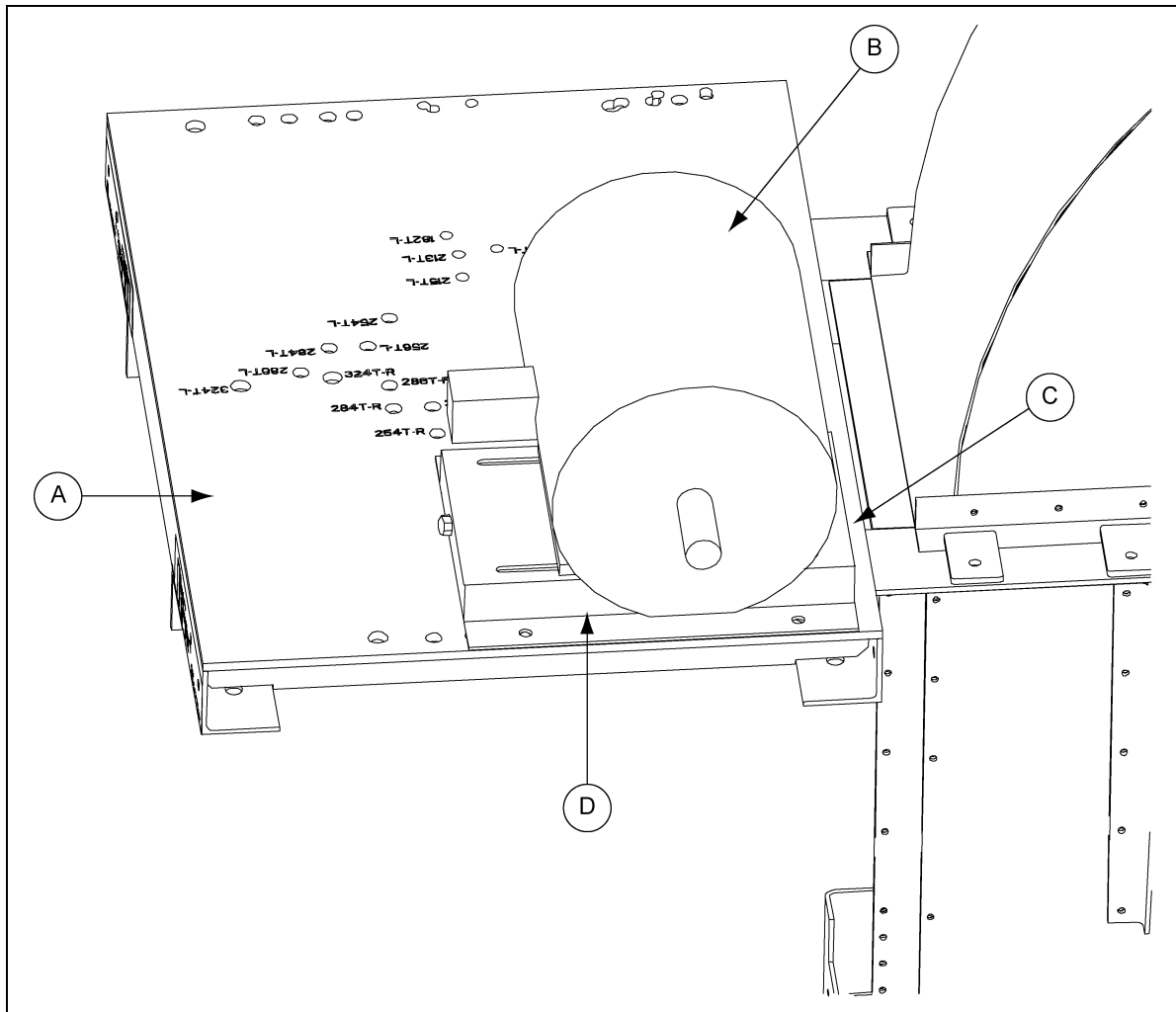

Figure 11C Motor Slide Base

Ref #	Description
A	Motor Mount
B	Motor
C	Tensioning Bolt
D	Motor Slide Base

## Torque Arm

1. Place the torque arm tube assembly on the head section by sliding the two (2) gussets of the torque arm assembly between the head bearing angles.
2. Make sure the locking bolts face away from the head section.
3. Attach with the proper hardware. (See Figure 11D below and Figure 11E on Page 38.)

**NOTE:** On 16" and 24" elevators, the torque arm tube will slide in and out freely with the motor's torque causing a positive lock situation.

**NOTE:** In 30" and large elevators, loosen the three (3) locking bolts and place the torque arm foot mounting tube in the torque arm assembly such that the foot mounting bracket is to the side in which the reducer will be mounted. Wait until the reducer is set on the shaft to re-tighten the locking bolts.

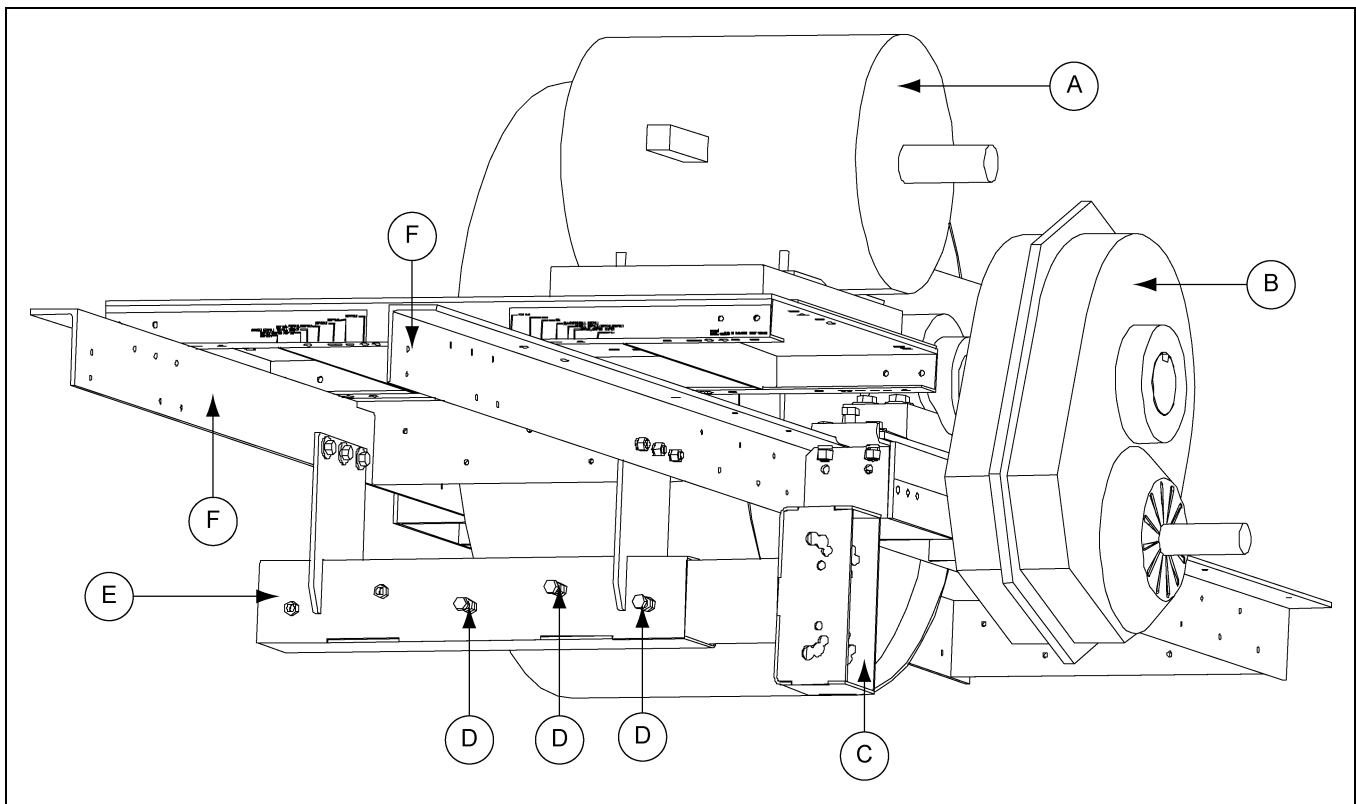

Figure 11D Torque Arm (30"-48")

Ref #	Description
A	Motor
B	Reducer Drive
C	Gusset
D	Locking Bolts
E	Torque Arm Tube
F	Head Bearing Angles

Torque Arm (Continued)

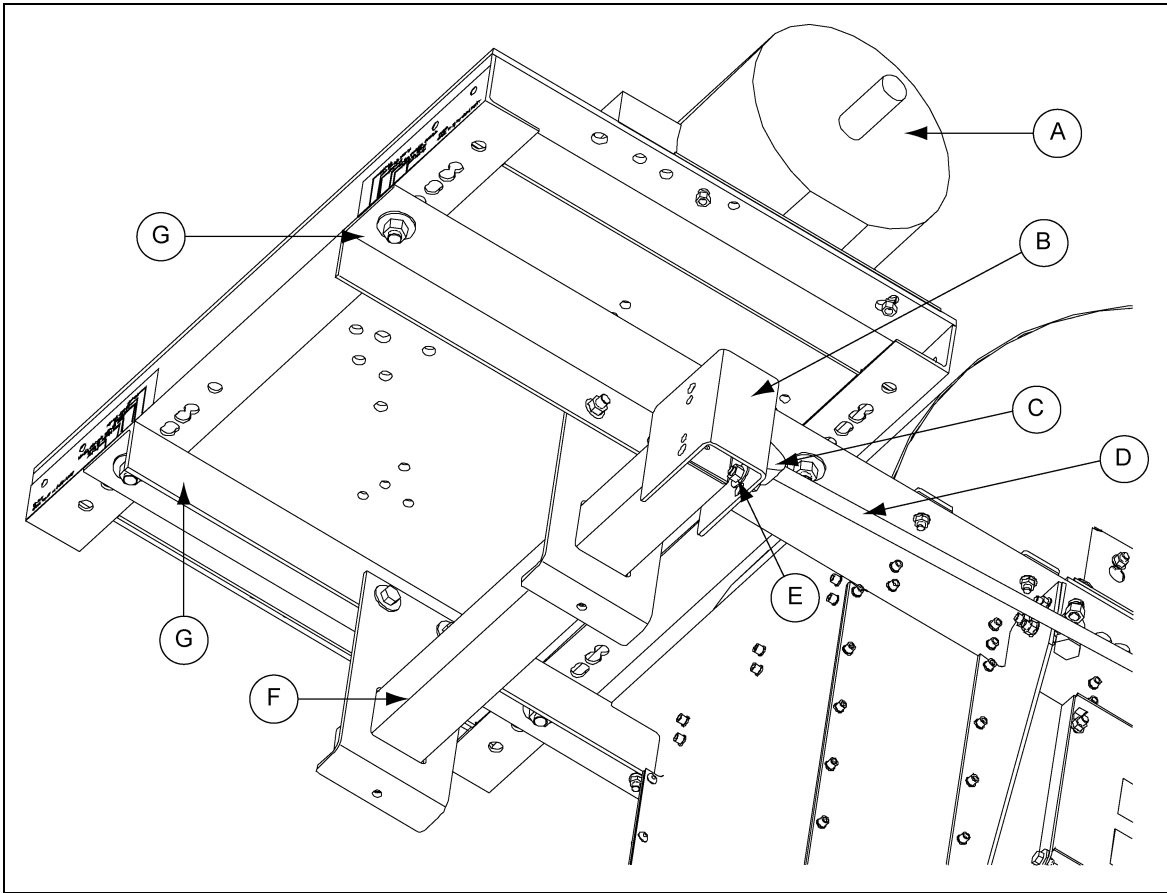

Figure 11E Torque Arm (16"-24")

Ref #	Description
A	Motor
B	Gusset
C	Foot
D	Turnbuckle
E	Nut
F	Torque Arm Tube
G	Head Bearing Angles

Shaft Mount Reducer

For reducer assembly, [See Page 49](#) of the Torque Arm II Reducer Installation Appendix which has detailed instructions for the reducer bushing mounting, cooling fans and backstops.

Once the reducer is assembled:

1. Attach the torque arm turnbuckle assembly to the reducer with proper hardware.
2. Attach the torque arm foot to the foot mounting bracket of the torque arm tube using the proper hardware.

### Drive Guard

1. Attach the drive guard brackets to the motor mount assembly. (See Figures 11F-11J on Pages 40-43.) The shorter, broken legs of the brackets will point towards the pulley.
2. Align the guard rear panel of the guard to the brackets. NOTE, in a right hand drive application (as shown in Figures 11F-11J on Pages 40-43) the flanges of the guard rear panel will face away from the head section, but in a left hand application, the flanges will point towards the head section.

**NOTE:** *The wider, larger hole in the guard rear panel is intended for the motor output shaft. The guard rear panel will attach only in one orientation.*

3. Once rear panel is bolted on, attach the drive guard struts to the bearing support of the head section and to the rear panel.
4. Using hardware, bolt the two (2) struts together. All brackets are designed to be adjustable.
5. Place sheaves onto the output shaft of the motor and the input shaft of the reducer.
6. Place belts upon the sheaves and tension as needed.

**NOTE:** *Reducer may need to be rotated, clockwise or counterclockwise, in conjunction with slide base adjustments, to achieve correct center distance for the drive belts. Move the location of the reducer torque arm turnbuckle to achieve this rotation, as needed.*

**NOTE:** *Belts are designed specifically per application.*

7. With drive belts tensioned and reducer rotated (if necessary), tighten all bolts.
8. Install the safety screen around the motor output shaft by approximating the hole location to the screen and snipping a clearance hole in screen. (See Figure 11F on Page 40.)
9. Attach using proper hardware.
10. Attach belt guard cover, latch and bolt.

**NOTE:** *Shaft mount reducers are shipped without lubricant.*



**NEVER operate the elevator until the gear reducer has been filled with an approved lubricant as noted in the Torque Arm II Appendix section on Page 49.**

11. With the reducer in vertical position, fill with lubricant until oil runs out of oil level plug.

**NOTE:** *See the Appendix section on Page 49 for volume of oil per reducer size.*

Drive Guard (Continued)

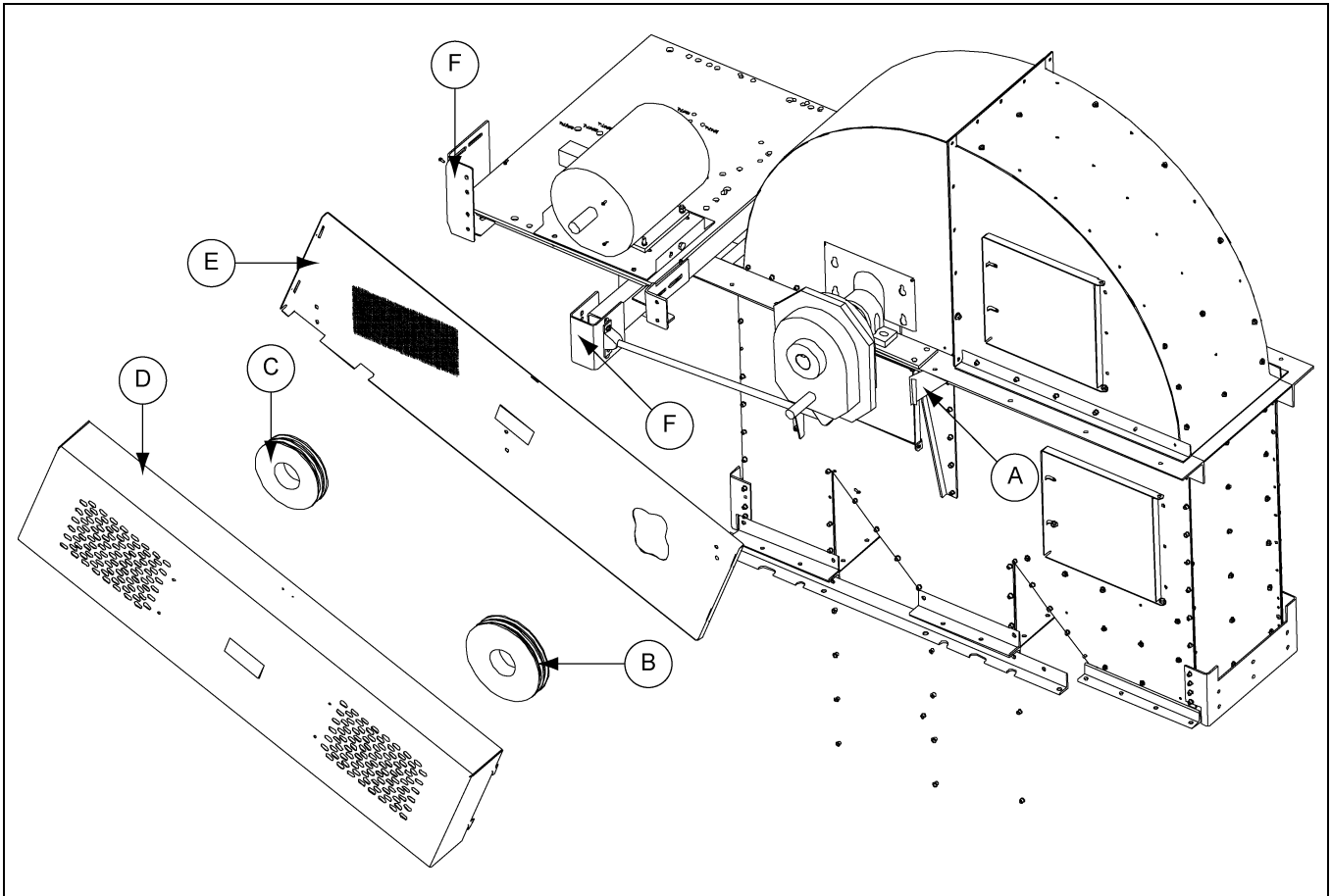

Figure 11F Belt Guard (Right hand drive shown.)

Ref #	Description
A	Side Bracket
B	Large Sheave
C	Small Sheave
D	Belt Guard Cover
E	Belt Guard Rear Panel
F	Mounting Brackets



Drive Guard (Continued)

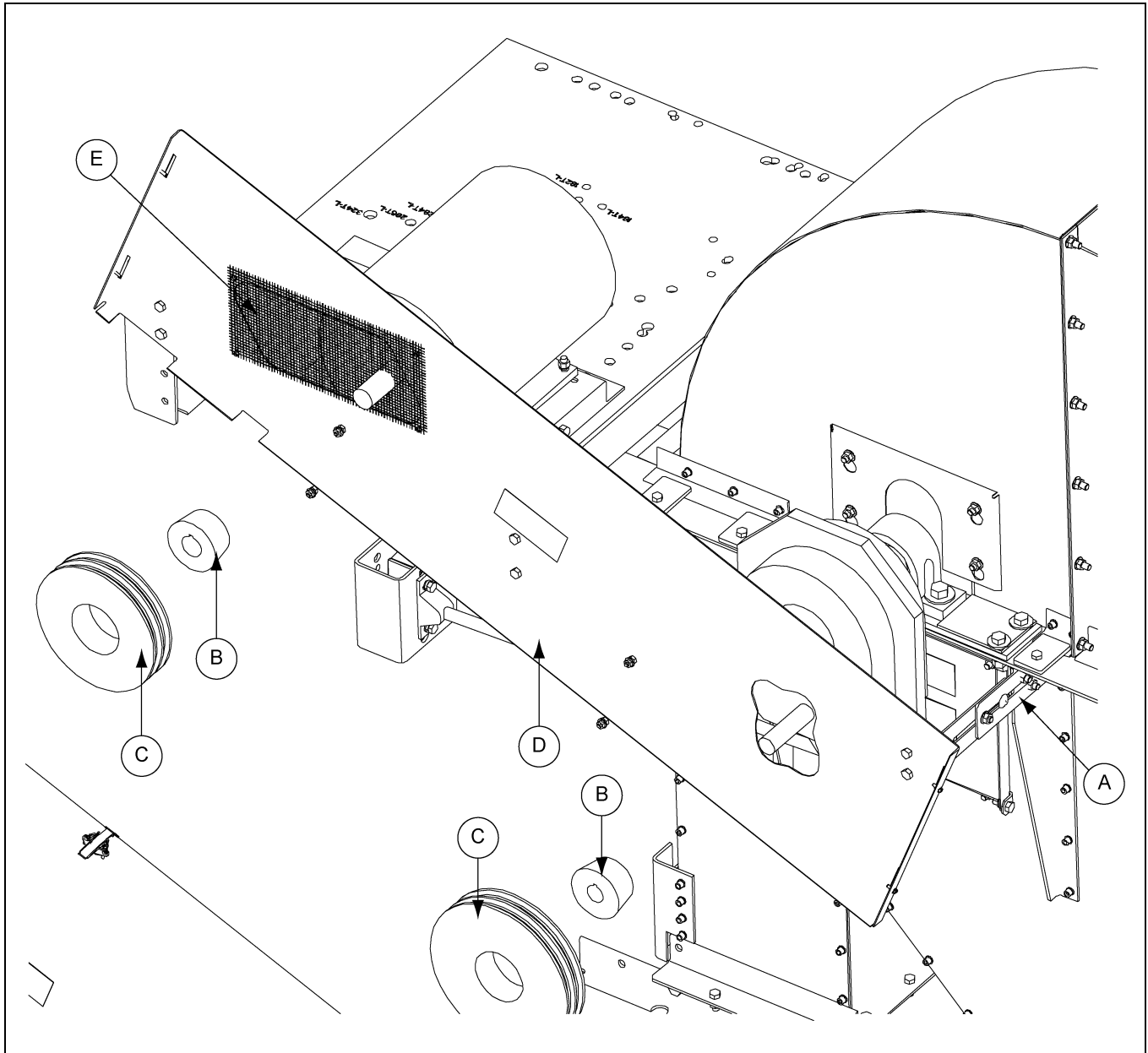

Figure 11G Belt Guard Mounted to Brackets

Ref #	Description
A	Slide Bracket
B	Bushing
C	Sheave
D	Rear Belt Guard Panel
E	Safety Screen (Hole must be cut out.)

Drive Guard (Continued)

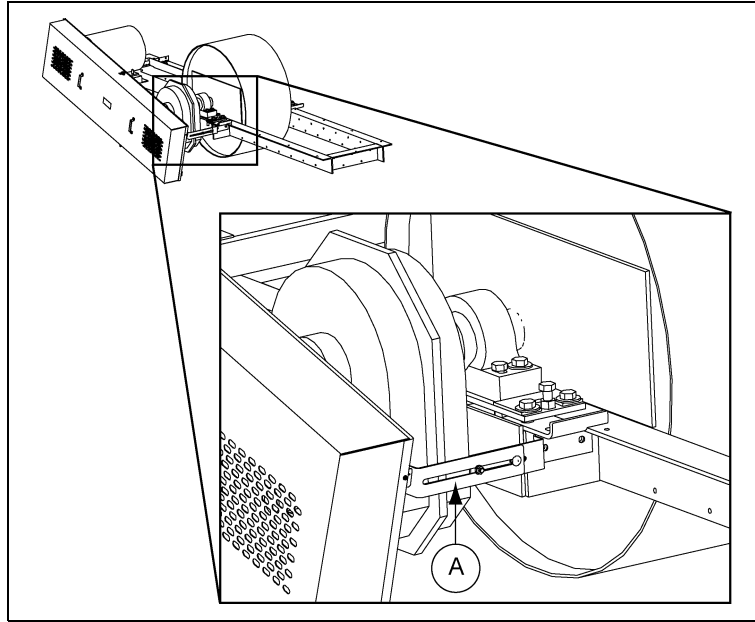

Figure 11H Slide Bracket

Ref #	Description
A	Slide Bracket

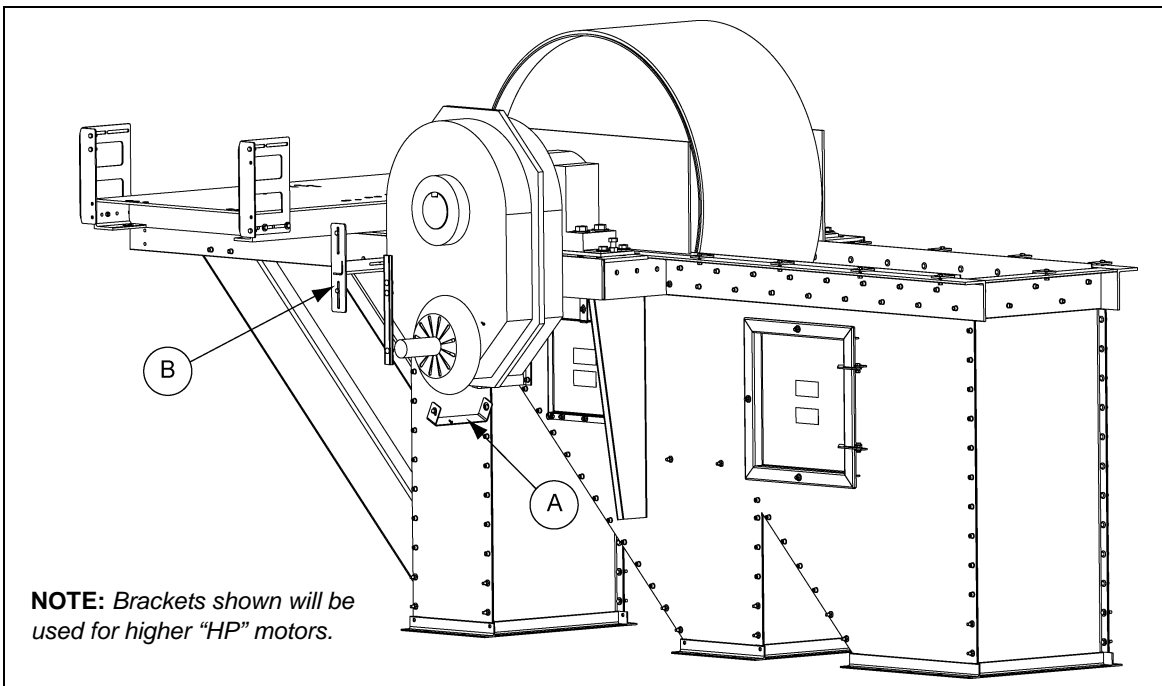

Figure 11I Brackets - Use for Higher HP Motors

Ref #	Part #	Description
A	DG-48T08200	Bracket, 48" Drive Guard, 200 HP+
B	DG-48T034	Plate, Middle Bracket 48"/42" Drive Guard

Drive Guard (Continued)

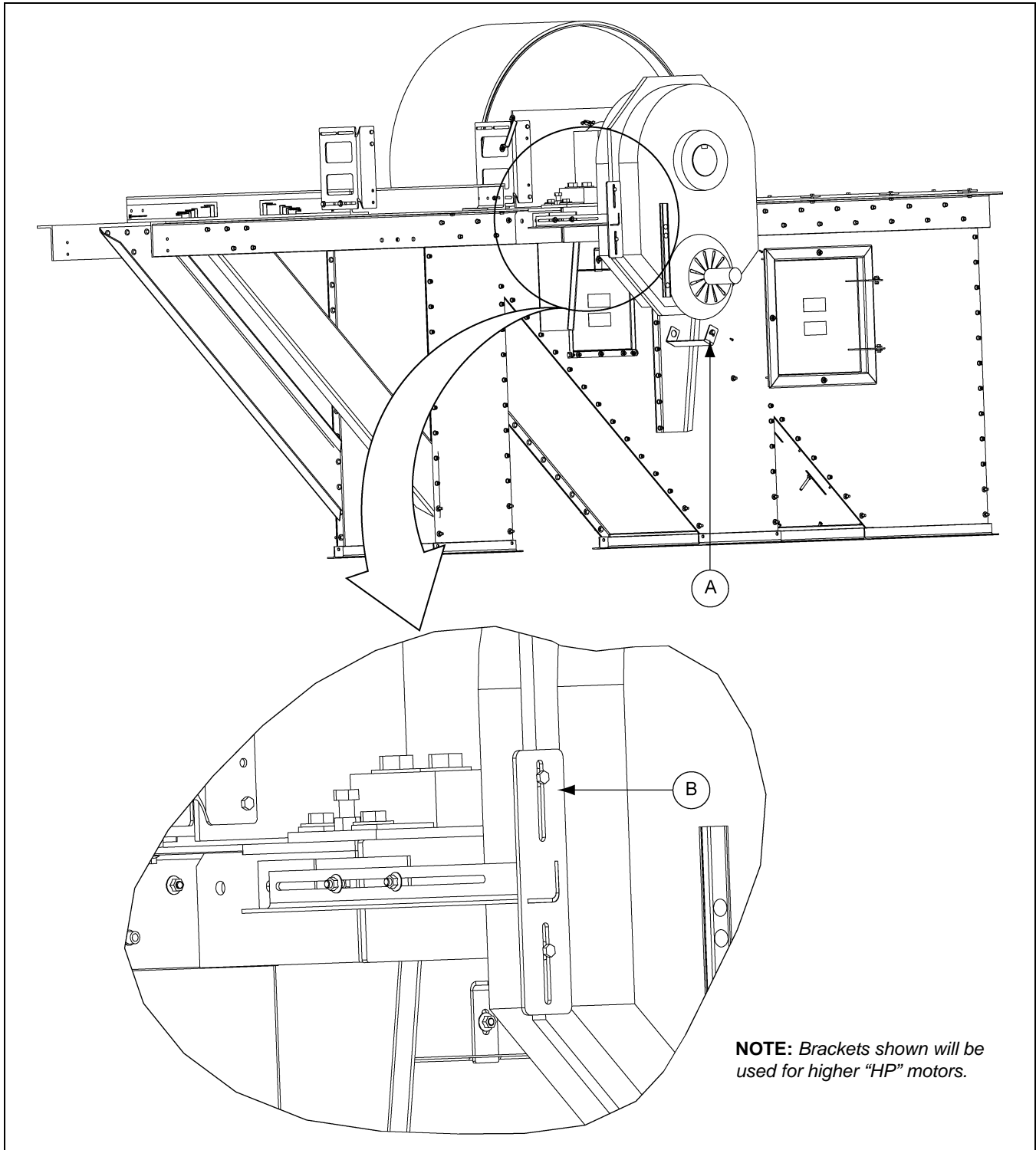

Figure 11J Brackets - Use for Higher HP Motors

Ref #	Part #	Description
A	DG-48T08200	Bracket, 48" Drive Guard, 200 HP+
B	DG-48T034	Plate, Middle Bracket 48"/42" Drive Guard

## 11. Drive Motor and Motor Mount

### Drive Belts

Drive belts are designed to fit loosely upon installation.

Use the motor mount adjustable slide base to properly tension belts to acceptable levels.

Proper tension is 0.4 mm (1/64") of deflection per, 25 mm (1") of sheave centers on one side of belt, centered between sheaves. (See Figure 11K.)

**NOTE:** Too much tension shortens belt life. Check belt tension frequently during the first 24-48 hours of operation.

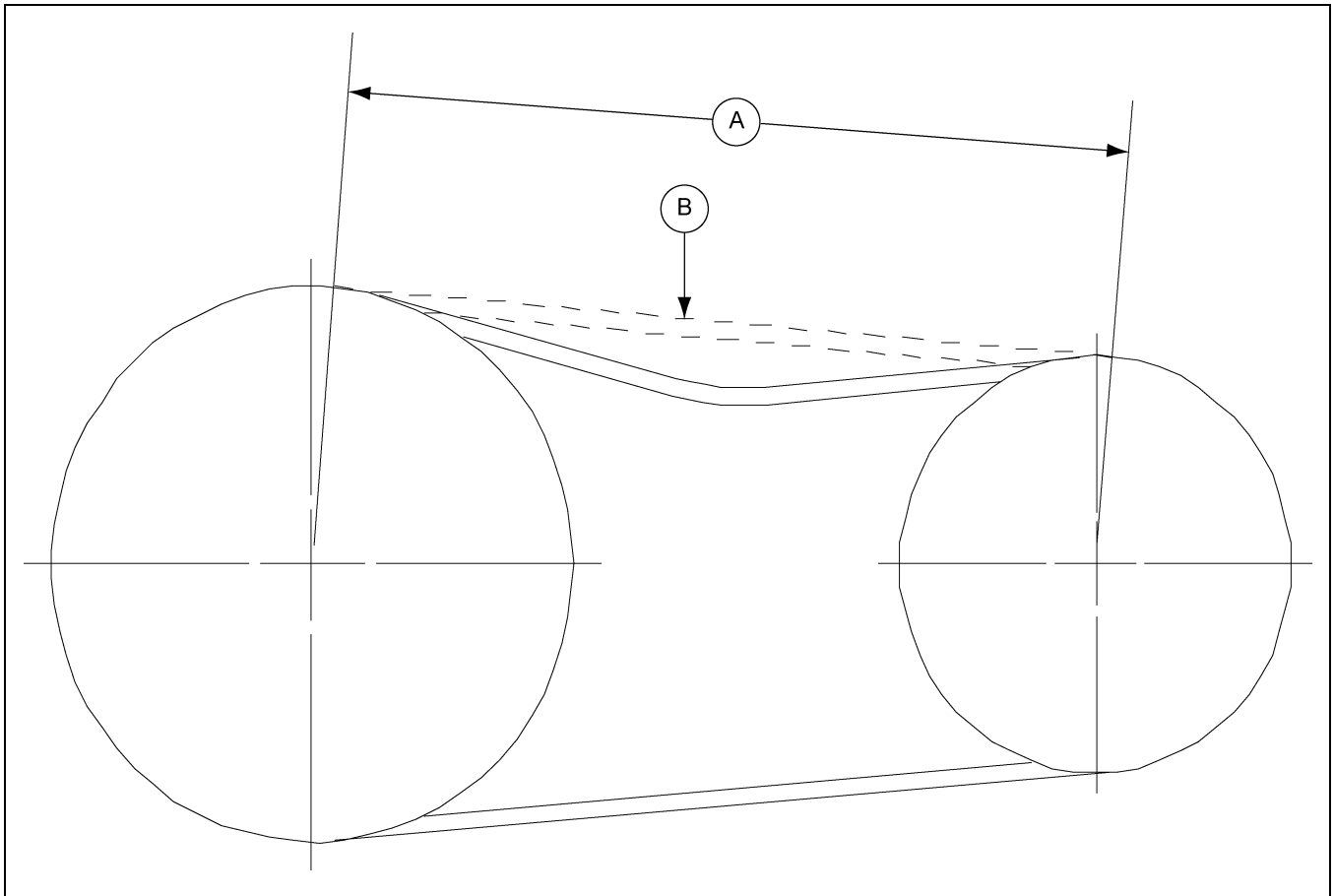

Figure 11K Drive Belt

Ref #	Description
A	Span
B	Force

### General Final Checks

1. Adjust the throat plate in the head discharge so there is approximately 1/4" clearance between it and edge of the buckets on the lap splice. (See Figure 12A.)

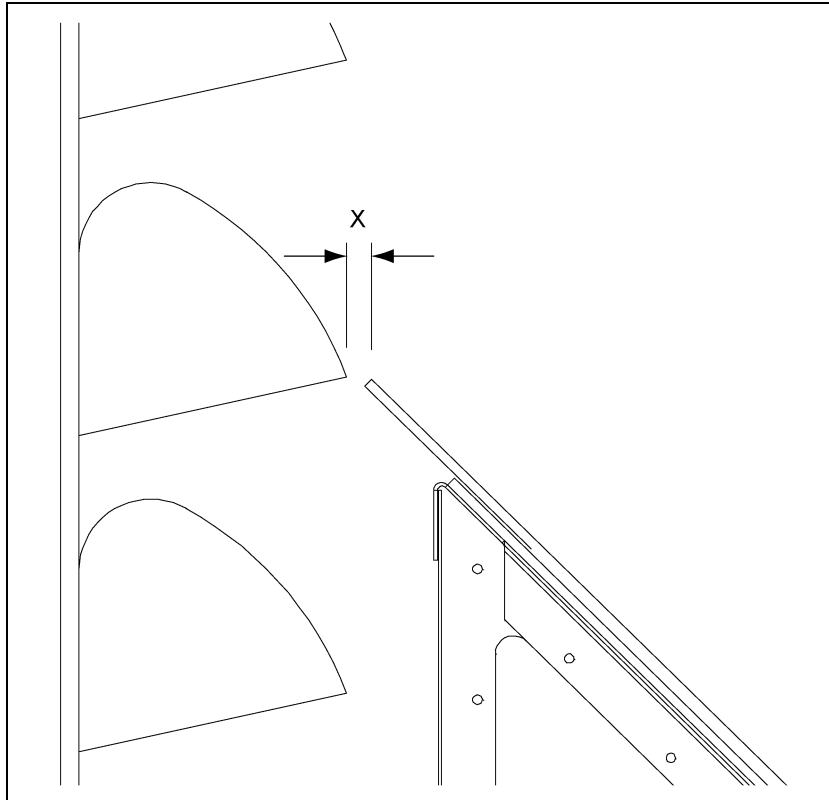

Figure 12A Throat Plate



1. Check clearance at the lap splice.
2. Do a final check of all parts to be sure all hardware is tight and no foreign objects or tools are left inside elevator.
3. Check all guards, inspection doors and removable plates to be sure they are in place and secure.
4. Tighten the take-up screws on the boot evenly to tighten the belt on the pulley, keeping bottom pulley level and work from side to side in small amounts until belt is tight.
5. Rotate by hand or carefully jog drive to check for proper rotation, clearance and operation of entire unit. Make any adjustments necessary.
6. Jog the drive a minimum of one complete revolution of belt. If no problems exist, carefully run the Bucket Elevator.

## 12. Final Checks, Tracking, Start-Up and Maintenance

---

### Belt Tracking

Tracking of the belt is very important for optimum results.

1. To correct any tracking problems.
  - First adjust the boot bearing plates.
  - Adjust the take-up screws downward on the side that the belt is tracking toward.
2. If this does not correct the problem or if the belt is tracking properly on the boot pulley but not the head pulley, further adjustments to the head pulley may be required.
3. The bearing side that the belt is tracking toward may need to be shimmed to compensate.
  - Loosen the head bearing bolts that go through the head angle.
  - Use the jacking screws to raise the bearing.
  - Place a full shim the bearing base.
  - Back off the screws.
  - Re-tighten the bearing mounting bolts.

**NOTE:** *Use thin shims to make small adjustments until the belt tracks properly.*

### Start-Up

Once you are sure all installations, safety checks, adjustments and lubrications have been completed:

1. Run the elevator for WITHOUT LOAD an initial break-in period of several hours.
2. Look and listen for any irregularities before running any material through the unit.
3. Re-check all moving parts and adjust as needed.
4. Adjust belt for final tension under load as needed.

### Maintenance

Regularly scheduled maintenance helps ensure long life and safe operation of the unit.

1. Routine maintenance checks may include general wear, loose nuts and bolts, electrical wiring, contacts, switches, misalignment, guy wire inspection, bearing seals and lubrication and oil content for gearbox.
2. The belt will stretch after installation and may need further adjustment. Expect some stretching during the first few weeks of operation.
3. On manual take-up boots, belt tension should be maintained by turning the boot take-up screws slowly and evenly to maintain proper tracking. When the screw adjustment is completely used, the belt will have to be re-spliced.

**NOTE:** *Good belt tension is critical for proper traction on the pulley and optimum performance.*

### Dealing with Elevator Blockages

Elevator blockage is an unlikely event, but can occur if the equipment being fed by the elevator becomes blocked. To resolve this, take the following steps:

1. Stop the elevator and run the down stream equipment to eliminate any down stream blockage.
2. Attempt to re-start the system.
3. If the elevator has become so blocked that it will not start freely, it may need to be emptied.  
Do not continually start and stop the elevator motor, as this will result in motor over heating and equipment damage.
4. Turn off the elevator; **lock out all power, lock and tag** the electrical power isolator so that the equipment cannot be re-started inadvertently. (See *Figure 12B.*)



Figure 12B

### Dealing with Elevator Blockages (Continued)

5. At the boot of the elevator, un-bolt and open the clean-out doors. (See Figure 12C.)

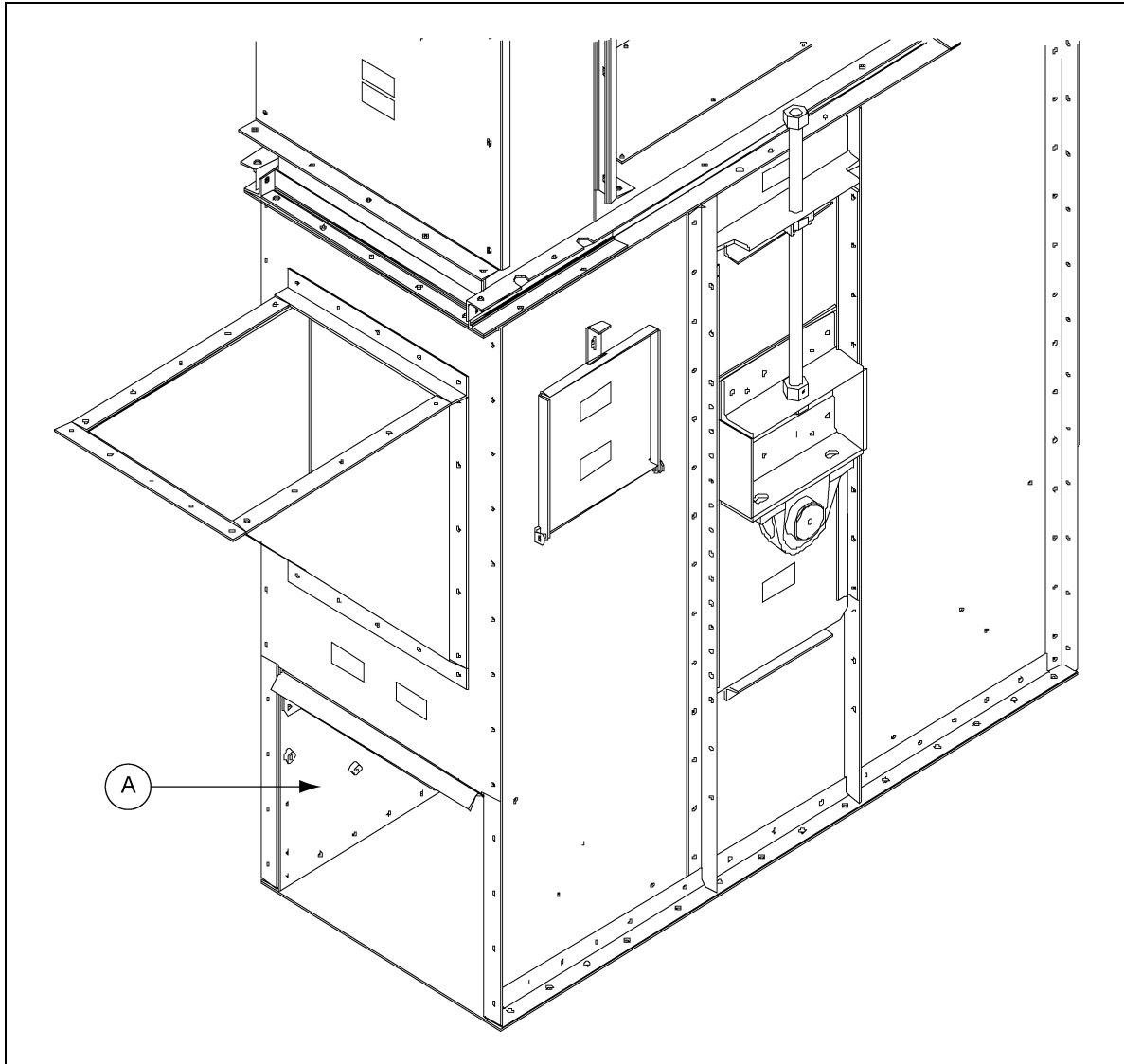

Figure 12C

Ref #	Description
A	Clean-Out Door

6. Allow grain to drop by gravity and remove by hand.
  - a. Do not attempt to run the elevator with the clean-out door open.
  - b. Do not attempt to have the elevator 'dig' itself out by running it with the clean-out door open.
7. Once grain has stopped running by gravity, replace the clean-out door and tighten all bolts.
8. Check that all other people are clear of the elevator and other equipment.
9. Unlock the electrical power and attempt to re-start the elevator.



Information regarding the torque arm, roller bearings and pillow blocks can be downloaded from the Baldor website.

Go to [www.baldor.com/support/product\\_manuals.asp](http://www.baldor.com/support/product_manuals.asp)

Enter the required manual number into the search field. See list below.

MN1601 - Dodge Torque-Arm II Speed Reducer Installation

MN3033 - Dodge S-2000 Spherical Roller Bearings

MN3040 - Dodge TAF Pillow Blocks and S-1 Units

---

# NOTES

## GSI Group, LLC Limited Warranty

The GSI Group, LLC ("GSI") warrants products which it manufactures to be free of defects in materials and workmanship under normal usage and conditions for a period of 12 months after sale to the original end-user or if a foreign sale, 14 months from arrival at port of discharge, whichever is earlier. The end-user's sole remedy (and GSI's only obligation) is to repair or replace, at GSI's option and expense, products that in GSI's judgment, contain a material defect in materials or workmanship. Expenses incurred by or on behalf of the end-user without prior written authorization from the GSI Warranty Group shall be the sole responsibility of the end-user.

### Warranty Extensions:

The Limited Warranty period is extended for the following products:

	Product	Warranty Period	
<b>AP Fans and Flooring</b>	Performer Series Direct Drive Fan Motor	3 Years	* Warranty prorated from list price: 0 to 3 years - no cost to end-user 3 to 5 years - end-user pays 25% 5 to 7 years - end-user pays 50% 7 to 10 years - end-user pays 75%
	All Fiberglass Housings	Lifetime	
	All Fiberglass Propellers	Lifetime	
<b>AP and Cumberland</b>	Flex-Flo/Pan Feeding System Motors	2 Years	
<b>Cumberland Feeding/Watering Systems</b>	Feeder System Pan Assemblies	5 Years **	** Warranty prorated from list price: 0 to 3 years - no cost to end-user 3 to 5 years - end-user pays 50%
	Feed Tubes (1-3/4" and 2.00")	10 Years *	
	Centerless Augers	10 Years *	
	Watering Nipples	10 Years *	
<b>Grain Systems</b>	Grain Bin Structural Design	5 Years	
<b>Grain Systems Farm Fans Zimmerman</b>	Portable and Tower Dryers	2 Years	† Motors, burner components and moving parts not included. Portable dryer screens included. Tower dryer screens not included.
	Portable and Tower Dryer Frames and Internal Infrastructure †	5 Years	

GSI further warrants that the portable and tower dryer frame and basket, excluding all auger and auger drive components, shall be free from defects in materials for a period of time beginning on the twelfth (12<sup>th</sup>) month from the date of purchase and continuing until the sixtieth (60<sup>th</sup>) month from the date of purchase (extended warranty period). During the extended warranty period, GSI will replace the frame or basket components that prove to be defective under normal conditions of use without charge, excluding the labor, transportation, and/or shipping costs incurred in the performance of this extended warranty.

### Conditions and Limitations:

THERE ARE NO WARRANTIES THAT EXTEND BEYOND THE LIMITED WARRANTY DESCRIPTION SET FORTH ABOVE. SPECIFICALLY, GSI MAKES NO FURTHER WARRANTY OF ANY KIND, EXPRESS OR IMPLIED, INCLUDING, WITHOUT LIMITATION, WARRANTIES OF MERCHANTABILITY OR FITNESS FOR A PARTICULAR PURPOSE OR USE IN CONNECTION WITH: (I) PRODUCT MANUFACTURED OR SOLD BY GSI OR (II) ANY ADVICE, INSTRUCTION, RECOMMENDATION OR SUGGESTION PROVIDED BY AN AGENT, REPRESENTATIVE OR EMPLOYEE OF GSI REGARDING OR RELATED TO THE CONFIGURATION, INSTALLATION, LAYOUT, SUITABILITY FOR A PARTICULAR PURPOSE, OR DESIGN OF SUCH PRODUCTS.

GSI shall not be liable for any direct, indirect, incidental or consequential damages, including, without limitation, loss of anticipated profits or benefits. The sole and exclusive remedy is set forth in the Limited Warranty, which shall not exceed the amount paid for the product purchased. This warranty is not transferable and applies only to the original end-user. GSI shall have no obligation or responsibility for any representations or warranties made by or on behalf of any dealer, agent or distributor.

GSI assumes no responsibility for claims resulting from construction defects or unauthorized modifications to products which it manufactured. Modifications to products not specifically delineated in the manual accompanying the equipment at initial sale will void the Limited Warranty.

This Limited Warranty shall not extend to products or parts which have been damaged by negligent use, misuse, alteration, accident or which have been improperly/inadequately maintained. This Limited Warranty extends solely to products manufactured by GSI.

Prior to installation, the end-user has the responsibility to comply with federal, state and local codes which apply to the location and installation of products manufactured or sold by GSI.

This equipment shall be installed in accordance with the current installation codes and applicable regulations, which should be carefully followed in all cases. Authorities having jurisdiction should be consulted before installations are made.

G S I G R O U P



**GSI Group**  
**1004 E. Illinois St.**  
**Assumption, IL 62510-0020**  
**Phone: 1-217-226-4421**  
**Fax: 1-217-226-4420**  
**[www.gsiag.com](http://www.gsiag.com)**



**GSI is a worldwide brand of AGCO Corporation.**