

# Distributor Cable Control

## Installation Manual

PNEG-971

Date: 05-08-07

GSI GROUP

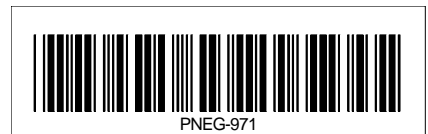

PNEG-971

---

### Equipment Information

Use of the Equipment Information page will help you identify your equipment in the case that you need call your dealer or installer. This information should be filled out and kept on record.

Model #: \_\_\_\_\_ Date Purchased: \_\_\_\_\_

Serial #: \_\_\_\_\_ Dealer name and phone #: \_\_\_\_\_

RPM: \_\_\_\_\_ \_\_\_\_\_

Head Pulley Dia.: \_\_\_\_\_ \_\_\_\_\_

Discharge Height: \_\_\_\_\_ \_\_\_\_\_

Horsepower: \_\_\_\_\_

Spout Dia.: \_\_\_\_\_

# of Spouts: \_\_\_\_\_

---

## Contents

<b>Chapter 1 Introduction</b> .....	<b>4</b>
<b>Chapter 2 Safety</b> .....	<b>5</b>
Safety Guidelines .....	5
Sign off Sheet.....	8
<b>Chapter 3 Decal Locations</b> .....	<b>9</b>
<b>Chapter 4 Part Identification</b> .....	<b>10</b>
<b>Chapter 5 Installation</b> .....	<b>11</b>
Installation of Cable Wheel & Coupler Connector.....	11
Connector Pulley Assembly .....	12
Cable Guide Assembly.....	13
Upper Cable Guide Assembly.....	14
Control Handle Installation .....	15
Lower Cable Wheel Assembly .....	16
Cable Guides .....	17
Cable Installation.....	18
<b>Chapter 6 Warranty</b> .....	<b>19</b>

# 1. INTRODUCTION

---

Thank you for choosing this product. It is designed to give excellent performance and service for many years.

This manual covers general information on the distributor cable control installation. Due to the wide variety of field conditions we cannot cover every aspect of installation. We offer one method for installing equipment but, rely on your qualified contractor's experience and techniques. Some conditions and surroundings do not allow certain practices during the installation of equipment. We can not be responsible for the installation of the distributor and accessories. We encourage anyone installing or maintaining this equipment to thoroughly read this manual before proceeding.

The company is the vendor of the distributor and certain of its optional accessories only and does not assume responsibility for the installation. The installation recommendations contained within this manual are for consideration only.

READ THIS MANUAL carefully to learn how to properly use and install this equipment. Failure to do so could result in personal injury or equipment damage.

INSPECT the shipment immediately upon arrival. The Customer is responsible for ensuring that all quantities are correct. Report any damage or shortages by recording a detailed description on the Bill of Lading to justify the Customer's claim from the Transport Firm. Our responsibility for damage to the equipment ends with acceptance by the delivering carrier. Save all paperwork and documentation furnished with any of the equipment.

THIS MANUAL SHOULD BE CONSIDERED a permanent part of your equipment and should be easily accessible when needed.

A WARRANTY is provided as part of the company's support program for customers who use and maintain their equipment as described in the manual. The warranty is explained on the [Warranty](#) page located on the inside back cover of this manual.

This warranty provides you the assurance that the company will back its products where defects appear within the warranty period. In some circumstances, the company also provides field improvements, often without charge to the customer, even if the product is out of warranty. Should the equipment be abused or modified to change its performance beyond the factory specifications, the warranty will become void and field improvements may be denied.

---

**Note: All information, illustrations, photos and specifications in this manual are based on the latest information available at the time of publication. The right is reserved to make changes at any time without notice.**

---

### Safety Guidelines

This manual contains information that is important for you, the owner/operator, to know and understand. This information relates to protecting **personal safety** and **preventing equipment problems**. It is the responsibility of the owner/operator to inform anyone operating or working in the area of this equipment of these safety guidelines. To help you recognize this information, we use the symbols that are defined below. Please read the manual and pay attention to these sections. Failure to read this manual and it's safety instructions is a misuse of the equipment and may lead to serious injury or death.



**This is the safety alert symbol. It is used to alert you to potential personal injury hazards. Obey all safety messages that follow this symbol to avoid possible injury or death.**



**DANGER** indicates an imminently hazardous situation which, if not avoided, will result in death or serious injury.



**WARNING** indicates a potentially hazardous situation which, if not avoided, could result in death or serious injury.



**CAUTION** indicates a potentially hazardous situation which, if not avoided, may result in minor or moderate injury.



**CAUTION** used without the safety alert symbol indicates a potentially hazardous situation which, if not avoided, may result in property damage.



**NOTE** indicates information about the equipment that you should pay special attention to.

## 2. SAFETY

### Follow Safety Instructions

Carefully read all safety messages in this manual and on your machine safety signs. Keep signs in good condition. Replace missing or damaged safety signs. Be sure new equipment components and repair parts include the current safety signs. Replacement safety signs are available from the manufacturer.

Learn how to operate the machine and how to use controls properly. Do not let anyone operate without instruction. Keep children and other unqualified out of the working area of ALL times.

Keep your machinery in proper working condition. Unauthorized modifications to the machine may impair the function and/or safety and affect machine life.

If you do not understand any part of this manual and need assistance, contact your dealer.

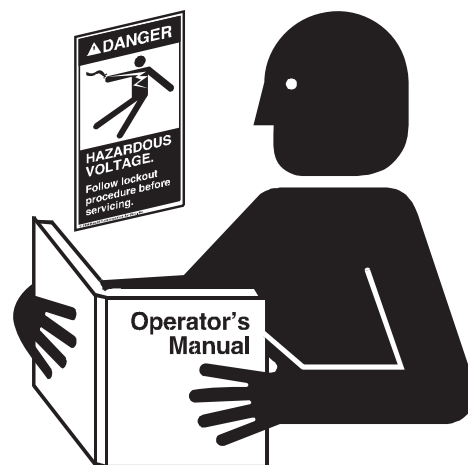

### Read and Understand Manual

### Prepare for Emergencies

Be prepared if fire starts.

Keep a first aid kit and fire extinguisher handy.

Keep emergency numbers for doctors, ambulance service, hospital and fire department near your telephone.

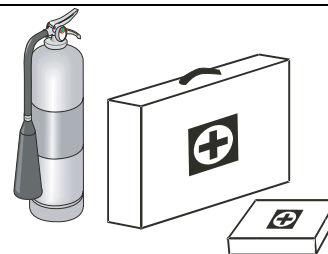

### Keep Emergency Equipment Quickly Accessible

### **Wear Protective Clothing**

Wear close fitting clothing and safety equipment appropriate to the job.

Safety glasses should be worn at all times to protect eyes from debris.

### **Eye Protection**

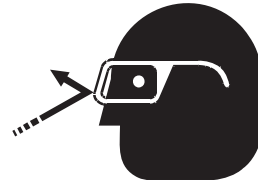

Wear gloves to protect your hands from sharp edges on plastic or steel parts.

### **Gloves**



Wear steel toe boots to help protect your toes from falling debris.

### **Steel Toe Boots**



A respirator may be needed if a hog house has poor ventilation. Waste fumes can be toxic.

### **Respirator**



Remove all jewelry.

Tuck in any loose or dangling shoe strings.

Long hair should be tied up and back.

Wear hard hat to help protect your head.

### **Hard Hat**



## 2. SAFETY

### Sign off Sheet

#### Employer/Employee Training Sign off Sheet

The principal concern of the company is your safety and the safety of others associated with grain handling equipment. It is the responsibility of the buyer to make this manual available to the person or persons involved with this equipment.

As owner and/or operator, it is your responsibility to know what requirements, hazards and precautions exist and to inform all personnel associated with the equipment or who are in the area. Failure to read this manual is a misuse of the equipment.

We have included this sign off sheet for you and your staff to use in the training process on installation and operation of the equipment described in this manual. Read the entire manual, sign off and date on [Chart below](#).

Date	Employees Name (printed)	Employee's Signature
	1	
	2	
	3	
	4	
	5	
	6	
	7	
	8	
	9	
	10	
	11	
	12	
	13	
	14	
	16	
	17	
	18	
	19	
	20	
	21	
	22	
	23	
	24	
	25	
	26	
	27	
	28	
	29	
	30	
	31	
	32	
	33	
	34	
	35	



### 3. DECAL LOCATIONS

Install safety decals on components as shown. Always insure that safety decals are in place and in good condition. If a decal cannot be easily read for any reason or has been painted over, replace it immediately. Contact your dealer or the manufacturer to order a replacement decal free of charge.

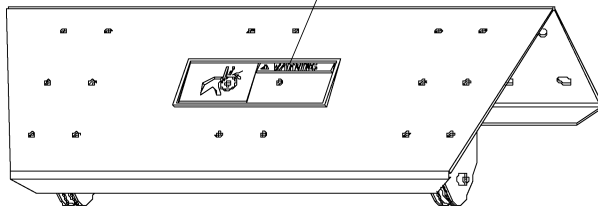

DC-857  
Located on the Cable Guide Assembly  
(GSB-0007)

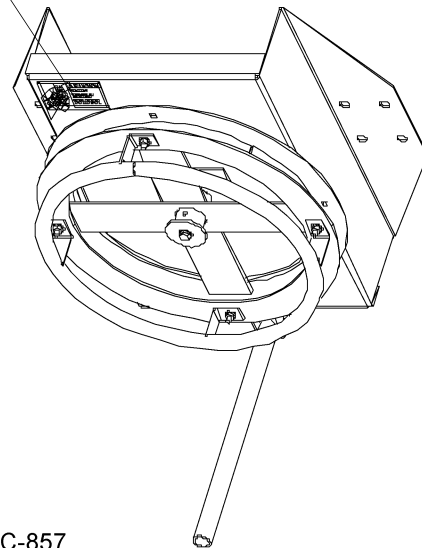

DC-857  
Located on the Cable Wheel Assembly  
(GSB-0045)

## 4. PART IDENTIFICATION

**Note: Cable is not supplied with cable control. 3/16" aircraft cable is recommended.**

6", 8", 10" Distributors - GSB-DCG		
Part #	Description	Qty
GSB-0006	Spacer, Bottom Guide	1
GSB-0007	Cable Guide Assembly, Top	1
GSB-0015	Cable Wheel Weldment, Top	1
GSB-0049	Cable Wheel Assembly, Bottom	1
GSB-0030	Control Handle	1
GSB-0031	Control Handle Brackets	2
GSB-0037	Coupler-Connector Weldment	1
GSB-0045	Connector-Pulley Assembly	1
GSB-DCG-HDW	Hardware, Dist. Cable Control	1

12" & 14" Distributors - GSB-DCG-1		
Part #	Description	Qty
GSB-0006	Spacer, Bottom Guide	1
GSB-0007	Cable Guide Assembly, Top	1
GSB-0059	Cable Wheel Weldment, Top	1
GSB-0049	Cable Wheel Assembly, Bottom	1
GSB-0030	Control Handle	1
GSB-0031	Control Handle Brackets	2
GSB-0052	Coupler-Connector Weldment	1
GSB-0045	Connector-Pulley Assembly	1
GSB-DCG-HDW	Hardware, Dist. Cable Control	1

Distributor Hardware - GSB-DCG-HDW		
Part #	Description	Qty
S-8762	Clamp 3/16" Cable	8
S-1146	Bolt HHCS 5/16-18 x 1 Zn Gr2	6
S-3611	Nut Flangewz 5/16" Zn	6
S-3729	Nut Hex 1/2"-13 Zn YDP Gr5	8
S-7329	Bolt HHCS 5/16-18 x 2 Zn Gr2	1
S-7382	Nut Nylock 5/16-18 Zn Gr5	1
S-8268	Bolt HHCS 1/2-13 x 2 Zn Gr8	8

10" Bucket Elevator - GSB-10DCG		
Part #	Description	Qty
GSB-10174	Clamp Band	4

16" - 36" Bucket Elevator - 1636 DCG		
Part #	Description	Qty
DSP16002	Clamp Band	4
DSP16005	Clamp Rod Weldment	2

## Installation of Cable Wheel & Coupler Connector

Once the distributor has been installed the installation of the cable controls can begin. The first piece to install is the cable wheel (GSB-0015/GSB-0059). This cable wheel mounts to the control pipe coming from the bottom of the distributor. This cable wheel needs to be placed on the pipe far enough not to interfere with the threads on the end of the distributor control pipe (See [Figure 5A](#)). Once the cable wheel is in the desired location, tighten the two 3/8" set screws.

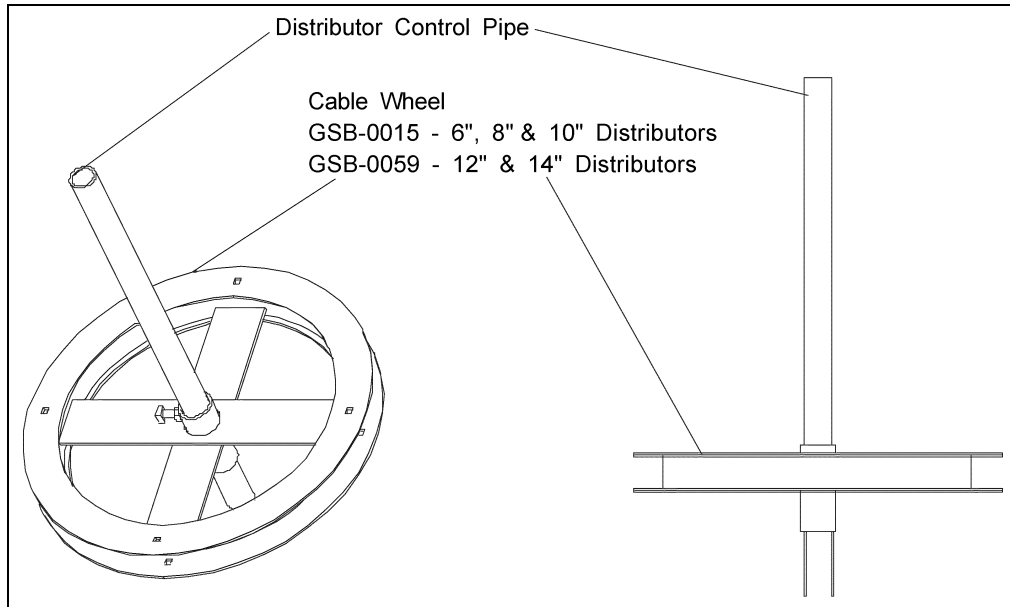

Figure 5A

Once the top cable wheel has been installed the next piece to assemble is the coupler-connector weldment (GSB-0037/GSB-0052). This piece threads onto the threads of the distributor control pipe as shown in [Figure 5B](#) below. Make sure the coupler-connector weldment is secured to the distributor control pipe.

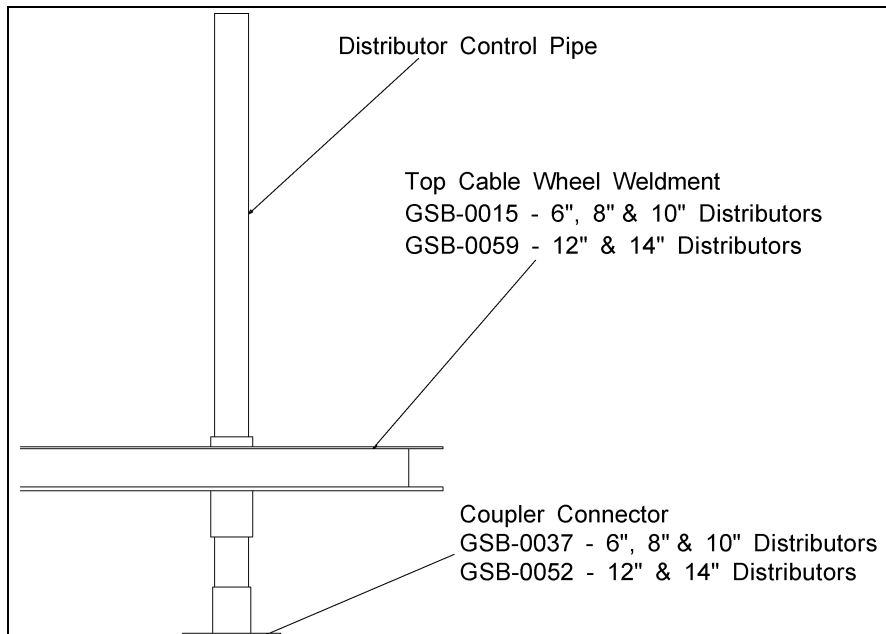

Figure 5B

## 5. INSTALLATION

### Connector Pulley Assembly

The next piece to install is the connector-pulley assembly (GSB-0045). This piece mounts to the coupler-connector weldment (GSB-0037/GSB-0052) as shown in *Figure 5C* below. These are fastened together using (2) 5/16" x 1" bolts and whizz nuts, supplied in the hardware package (GSB-DCG-HDW).

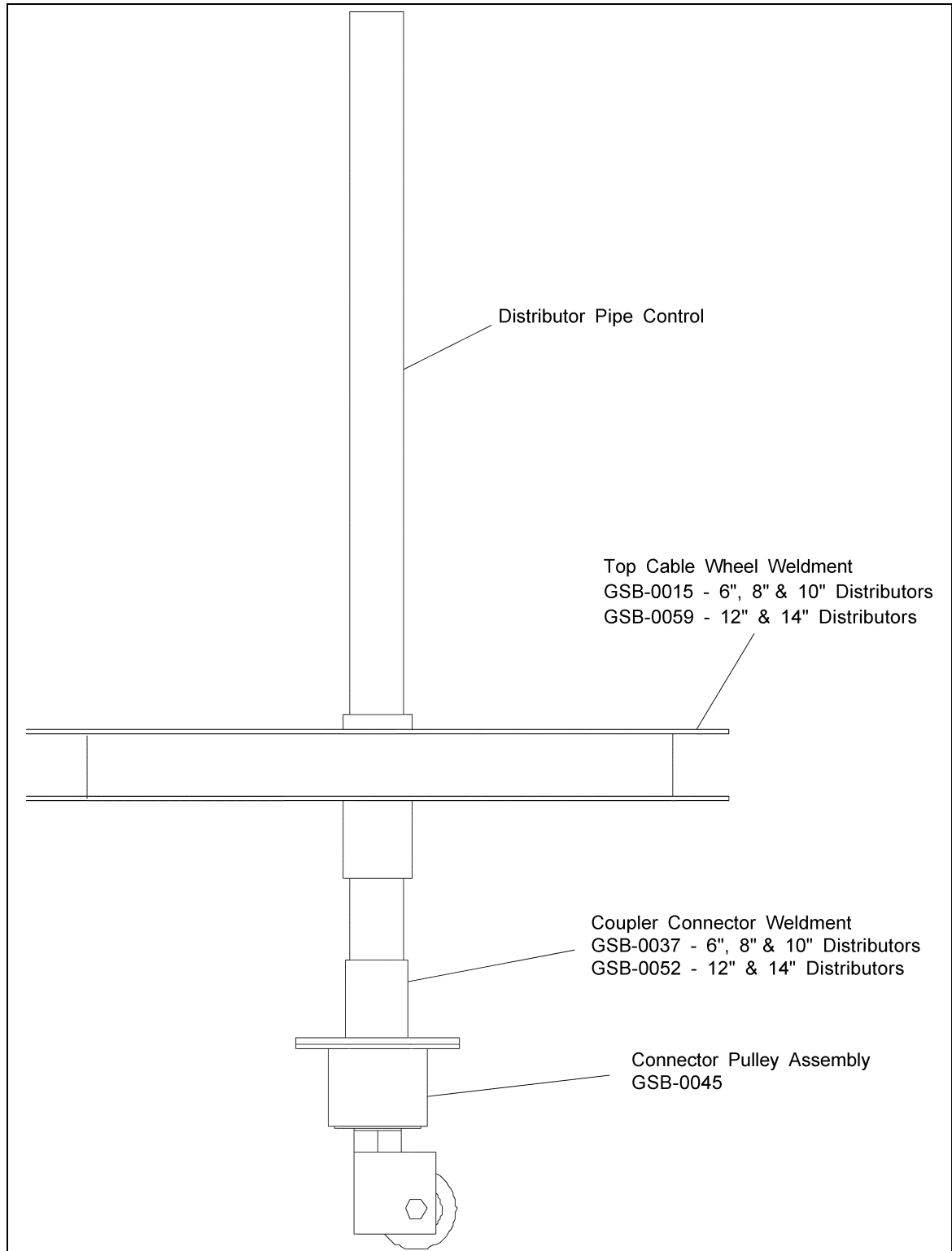

Figure 5C

### Cable Guide Assembly

The next piece to install is the upper cable guide assembly (GSB-0007). The cable guide assembly is installed on the trunking. The location on the trunking is determined by the height of the cable wheel (GSB-0015/GSB-0059). The cable must run in-line from the cable wheel to the sheaves in the cable guide assembly. This location is shown in [Figure 5D](#) below. For cable installation [see page 18](#).

---

**Note:** *Cable is not supplied with cable control. The company recommends 3/16" aircraft cable.*

---

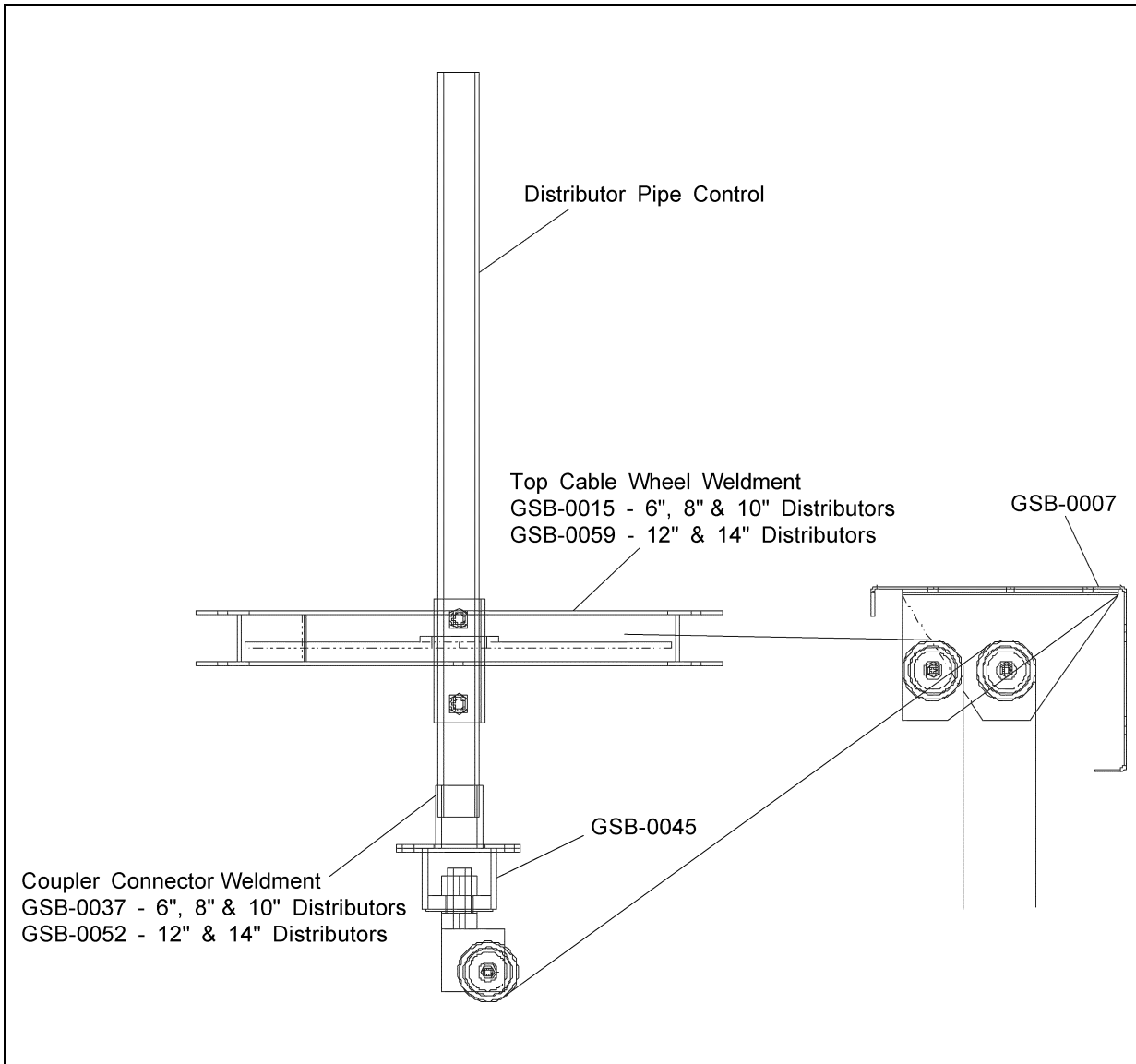

Figure 5D

## 5. INSTALLATION

### Upper Cable Guide Assembly

Once the location of the upper cable guide assembly is determined it must be fastened to the trunking. The assembly of the clamp band and upper cable guide assembly (GSB-0007) is shown in the [Figure 5E](#) & [Figure 5F](#) below. The 1/2" x 2" bolts and nuts that fasten the clamp bands to the upper cable guide assembly are provide in the hardware package (GSB-DCG-HDW). These clamp bands vary depending on what size leg you have. [Refer to the Tables below to see what clamp be used.](#)

**Note:** Use caution when tightening hardware, Do not overtighten and collapse trunking.

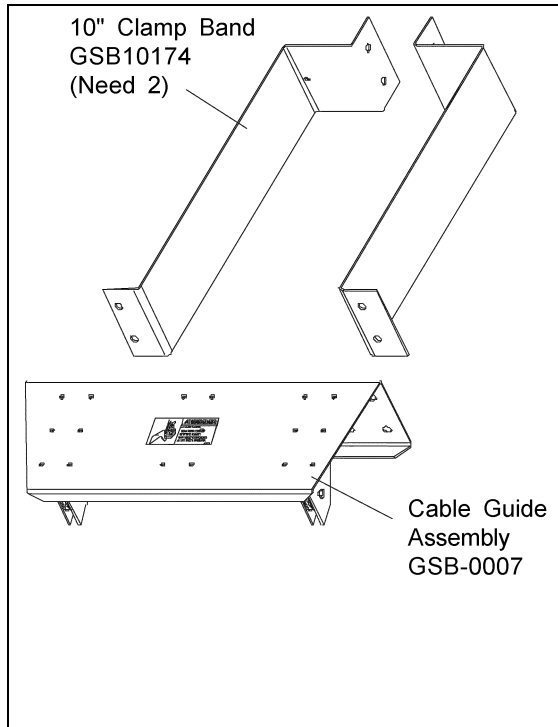

**Figure 5E** Trunking Removed for Clarity

Pulley Dia.	Clamp Band	Qty
10"	GSB10174	2

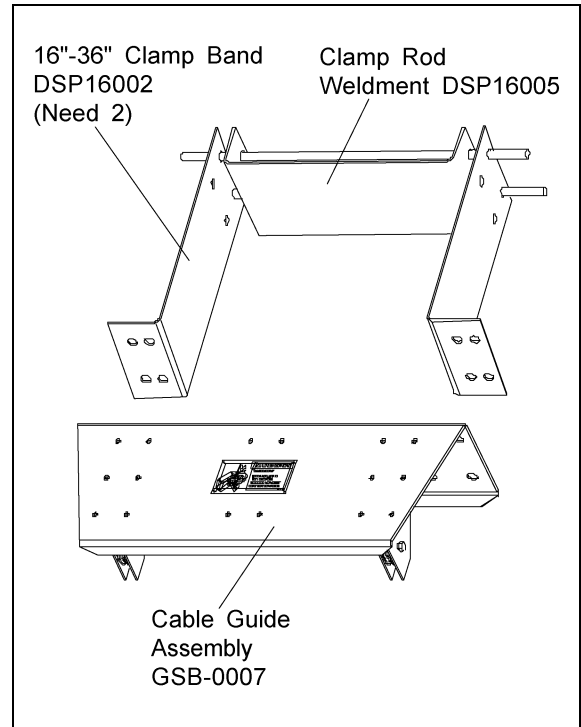

**Figure 5F** Trunking Removed for Clarity

16", 24", 30" & 36" Pulleys	Part #	Qty
Clamp Band	DSP16002	2
Clamp w/Rod Weldment	DSP16005	1

### Control Handle Installation

Once the upper assembly has been installed, the control handle needs to be assembled to the lower cable wheel assembly. There are two brackets (GSB-0031) that mount to the bottom of the lower cable wheel assembly (GSB-0049). These brackets are fastened with 5/16" x 1" bolts and whiz nuts. The control handle (GSB-0030) is then mounted between the brackets using the second hole in the control handle and the end hole on the brackets. This is fastened using 5/16" x 2" bolt and lock nut. The hardware required is located in (GSB-DCG-HDW). This assembly is shown in [Figure 5G](#) below.

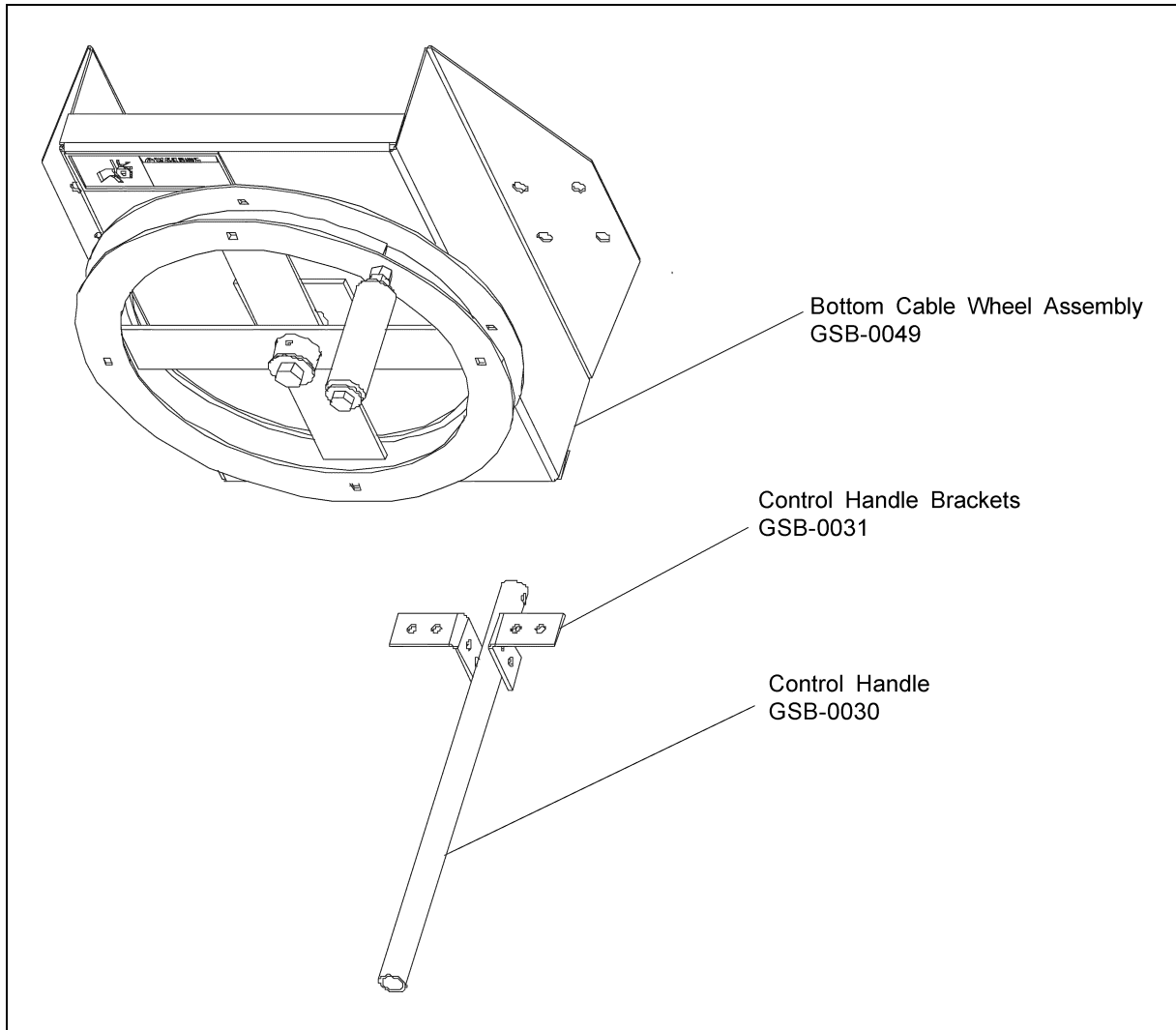

Figure 5G

## 5. INSTALLATION

### Lower Cable Wheel Assembly

Once the control handle has been assembled the lower cable wheel can be installed. The location of the lower cable wheel assembly (GSB-0049) is decided by where the operator will be positioned. Once the desired height has been determined for the lower cable wheel, it must be fastened to the trunking. The assembly of the lower cable wheel and clamp bands are shown in [Figure 5H](#) below. The 1/2" x 2" bolts and nuts to fasten clamp bands to the lower cable wheel are provided in the hardware package (GSB-DCG-HDW). These clamp bands vary depending on what size leg you have. Refer to tables on [Page 14](#) to see what clamp bands should be used.

**Note:** Use caution when tightening hardware, Do not overtighten and collapse trunking.

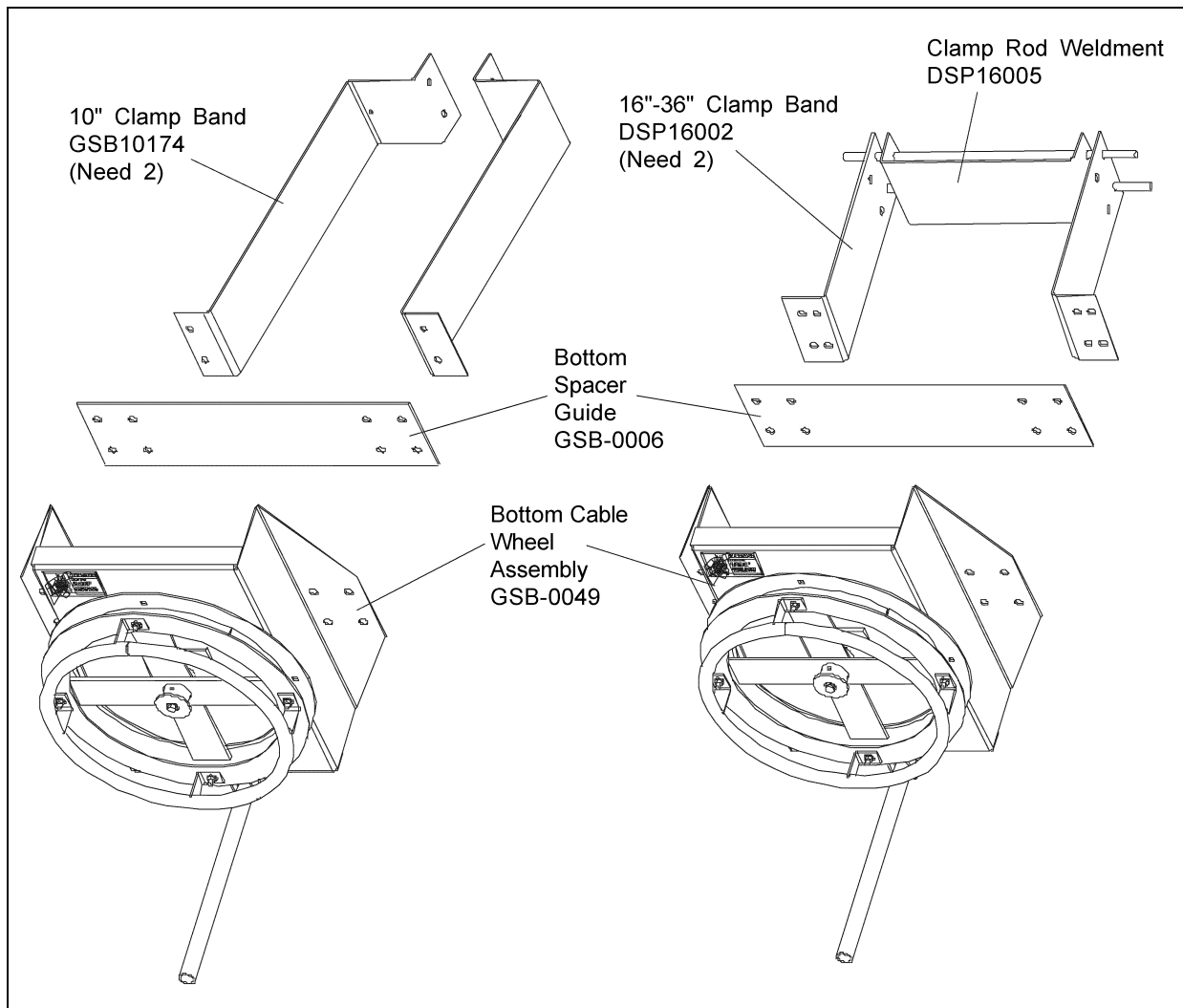

Figure 5H Trunking Removed for Clarity



### Cable Guides

To help keep the cable in-line from the upper assembly to lower assembly intermediate cable guides need to be installed. The quantity of the intermediate cable guides is determined by the height of the leg. The company recommends that they be installed every 20 feet. These intermediate cable guides (GSB-0022) are fastened at the trunking joints using the same hardware as the joint. The assembly below shows how the intermediate cable guides are located on the trunk joints (*See Figure 5I*). For cable installation [see page 18](#).

**Note:** *Cable is not supplied with cable control. The company recommends 3/16" aircraft cable.*

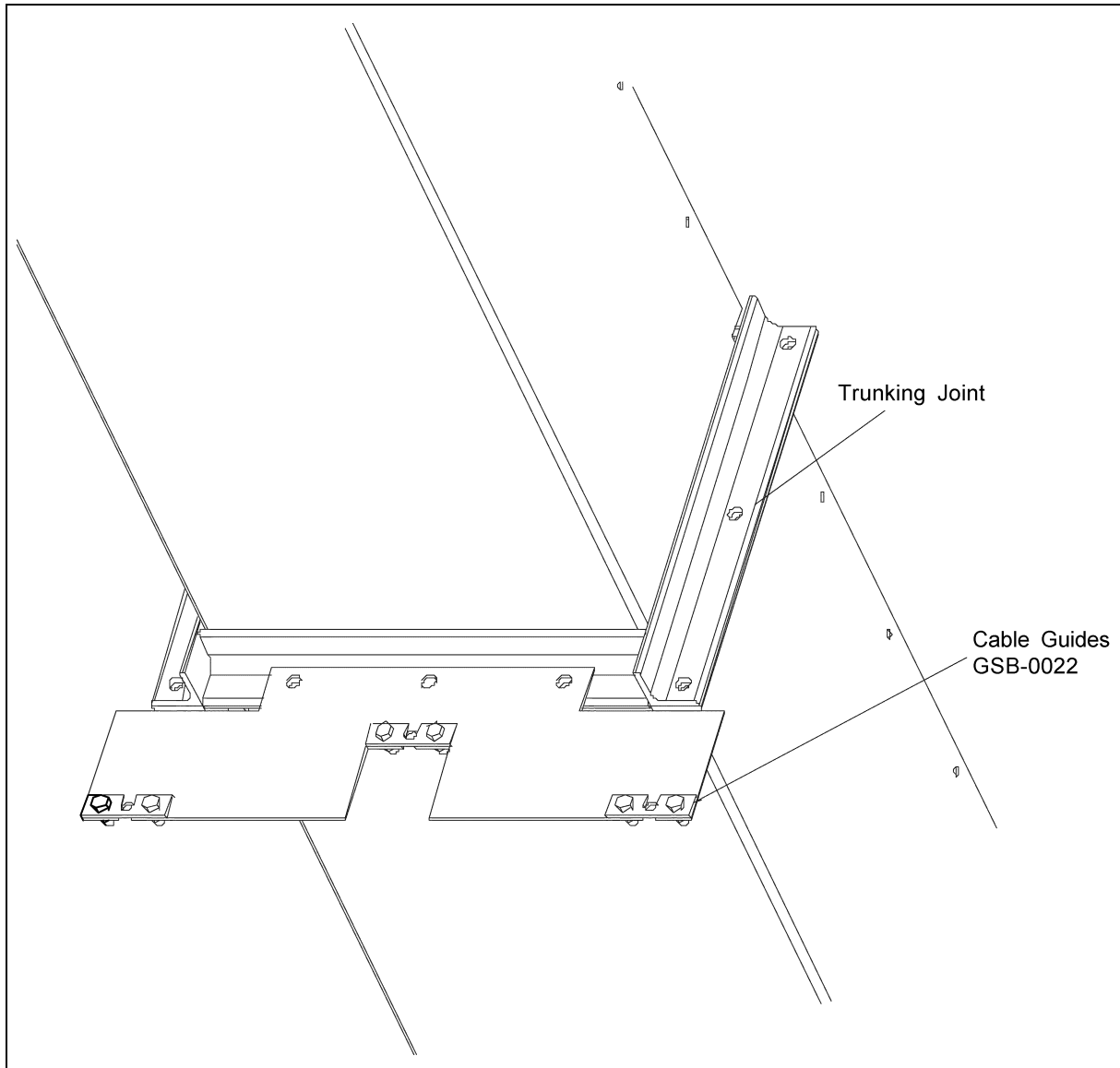

Figure 5I

## 5. INSTALLATION

---

### Cable Installation

There is more than one way to install the cable for the cable control, we offer one method for installation. Rely on your qualified contractor's experience and techniques.

You will need two pieces of cable. One piece should be long enough to reach from distributor to the lower control wheel assembly. Make sure there is enough extra to tie off both ends of cable. The other piece will have to be long enough to go from distributor to lower cable wheel assembly and back up to distributor. Make sure there is enough extra to wrap around the cable wheels approximately 7 times. The shorter piece will be used for lifting the spout inside distributor and the longer piece will be used to turn the spout.

With shorter piece of cable, take it and run through center pulley in upper cable guide assembly (See Figure 5E) & (See Figure 5F). Then run cable over to pulley (GSB-0045) on control pipe of distributor and continuing feeding cable up through control pipe in distributor (See Figure 5D). Make sure cable is fed through all pulleys that are inside distributor. Attach this end to the sliding mechanism inside distributor by looping through eye in slide mechanism. Attach cable back to itself using cable clamp. Once this end is attached, run the cable down the side of the leg to the lower cable wheel assembly (See Figure 5H), running through cable guides when necessary (See Figure 5I). Attach this end to the control handle (GSB-0030) on the lower cable wheel assembly by looping through end hole and attach cable back to itself using cable clamp (See Figure 5H). The control handle will be pulled up to let spout turn inside distributor. Make sure when cable is clamped together that control handle still has enough travel upward to allow the spout to turn.

Take the longer piece of cable and mark the center. Start at the upper cable wheel on the control pipe of the distributor (See Figure 5C). Start at the center of the cable and wrap it around the cable wheel a minimum of three times. Take the ends of the cable and run them over to the upper cable guide assembly (See Figure 5D). Feed the ends through the two outside pulleys. Then run both cables down the leg to the lower cable wheel assembly (See Figure 5H), running through cable guides as necessary (See Figure 5H). Take one end of cable and wrap around cable wheel a minimum of two times. Loop through one of the square holes inside of cable wheel and attach back to itself with cable clamp. Take the other end and wrap a minimum of two times. Loop end through one of the square holes inside on cable wheel, on opposite side as other cable end and attach back to itself with cable clamp.

---

**Note:** *Cable is not supplied with cable control. The company recommends 3/16" aircraft cable.*

---

## 6. WARRANTY

### Warranty

THE GSI GROUP, INC. (GSI) WARRANTS ALL PRODUCTS WHICH IT MANUFACTURES TO BE FREE OF DEFECTS IN MATERIAL AND WORKMANSHIP UNDER NORMAL USAGE AND CONDITIONS FOR A PERIOD OF 12 MONTHS AFTER RETAIL SALE TO THE ORIGINAL END USER. THE PURCHASER'S SOLE REMEDY AND GSI'S ONLY OBLIGATION SHALL BE TO REPAIR OR REPLACE, AT GSI'S OPTION AND EXPENSE, PRODUCTS THAT, IN GSI'S SOLE JUDGMENT, CONTAIN A MATERIAL DEFECT DUE TO MATERIALS OR WORKMANSHIP. ALL DELIVERY AND SHIPMENT CHARGES TO AND FROM GSI'S FACTORY WILL BE PURCHASER'S RESPONSIBILITY. EXPENSES INCURRED BY OR ON BEHALF OF THE PURCHASER WITHOUT PRIOR WRITTEN AUTHORIZATION FROM AN AUTHORIZED EMPLOYEE OF GSI SHALL BE THE SOLE RESPONSIBILITY OF THE PURCHASER.

EXCEPT FOR THE LIMITED WARRANTY EXPRESSED ABOVE, GSI MAKES NO FURTHER WARRANTY OF ANY KIND, EXPRESS OR IMPLIED, INCLUDING, WITHOUT LIMITATION, WARRANTIES OF MERCHANTABILITY OR FITNESS FOR A PARTICULAR PURPOSE OR USE IN CONNECTION WITH (I) PRODUCT MANUFACTURED OR SOLD BY GSI OR (I) ANY ADVICE, INSTRUCTION, RECOMMENDATION OR SUGGESTION PROVIDED BY AN AGENT, REPRESENTATIVE OR EMPLOYEE OF GSI REGARDING OR RELATED TO THE CONFIGURATION, INSTALLATION, LAYOUT, SUITABILITY FOR A PARTICULAR PURPOSE, OR DESIGN OF SUCH PRODUCTS.

GSI SHALL NOT BE LIABLE FOR ANY DIRECT, INDIRECT, INCIDENTAL OR CONSEQUENTIAL DAMAGES, INCLUDING, WITHOUT LIMITATION, LOSS OF ANTICIPATED PROFITS OR BENEFITS. PURCHASER'S SOLE AND EXCLUSIVE REMEDY IS AS SET FORTH IN THE LIMITED WARRANTY EXPRESSED ABOVE, WHICH SHALL NOT EXCEED THE AMOUNT PAID FOR THE PRODUCT PURCHASED. THIS WARRANTY IS NOT TRANSFERABLE AND APPLIES ONLY TO THE ORIGINAL PURCHASER. GSI SHALL HAVE NO OBLIGATION OR RESPONSIBILITY FOR ANY REPRESENTATIONS OR WARRANTIES MADE BY OR ON BEHALF OF ANY DEALER, AGENT OR DISTRIBUTOR OF GSI.

GSI ASSUMES NO RESPONSIBILITY FOR CLAIMS RESULTING FROM ERECTION DEFECTS OR UNAUTHORIZED MODIFICATIONS TO PRODUCTS WHICH IT MANUFACTURED. MODIFICATIONS TO PRODUCTS NOT SPECIFICALLY DELINEATED IN THE MANUAL ACCOMPANYING THE EQUIPMENT AT INITIAL SALE WILL NULLIFY THE PRODUCT WARRANTY THAT MIGHT HAVE BEEN OTHERWISE AVAILABLE.

THE FOREGOING WARRANTY SHALL NOT EXTEND TO PRODUCTS OR PARTS WHICH HAVE BEEN DAMAGED BY NEGLIGENT USE, MISUSE, ALTERATION OR ACCIDENT. THIS WARRANTY EXTENDS SOLELY TO ONLY PRODUCTS MANUFACTURED BY GSI. THIS WARRANTY IS EXCLUSIVE AND IN LIEU OF ALL OTHER WARRANTIES EXPRESS OR IMPLIED. GSI RESERVES THE RIGHT TO MAKE DESIGN OR SPECIFICATION CHANGES AT ANY TIME.

PRIOR TO INSTALLATION, PURCHASER HAS THE RESPONSIBILITY TO COMPLY WITH ALL FEDERAL, STATE AND LOCAL CODES WHICH MAY APPLY TO THE LOCATION AND INSTALLATION OF PRODUCTS MANUFACTURED OR SOLD BY GSI.

This equipment shall be installed in accordance with the current installation codes and applicable regulations which should be carefully followed in all cases. Authorities having jurisdiction should be consulted before installations are made.

G S I G R O U P



**GSI Group, Inc.**  
**1004 E. Illinois St.**  
**Assumption, IL 62510-0020**  
**Phone: 1-217-226-4421**  
**Fax: 1-217-226-4420**  
**Internet: <http://www.grainsystems.com>**