

# Z-Flow Gravity Screener

## Assembly Manual



**PNEG-1345**

Date: 9-15-03





# Introduction

READ THIS MANUAL carefully to learn how to properly use and install equipment. Failure to do so could result in personal injury or equipment damage.

INSPECT the shipment immediately upon arrival. The Customer is responsible for ensuring that all quantities are correct. Report any damage or shortages by recording a detailed description on the Bill of Lading to justify the Customer's claim from the Transport Firm. Our responsibility for damage to the equipment ends with acceptance by the delivering carrier. Save all paperwork and documentation furnished with any of the enclosed belt conveyor components.

THIS MANUAL SHOULD BE CONSIDERED a permanent part of your equipment and should be easily accessible when needed.

WARRANTY is provided as part of the company's support program for customers who use and maintain their equipment as described in the manual. The warranty is explained on the warranty page located on the inside back cover of this manual.

This warranty provides you the assurance that the company will back its products where defects appear within the warranty period. In some circumstances, the company also provides field improvements, often without charge to the customer, even if the product is out of warranty. Should the equipment be abused, or modified to change its performance beyond the factory specifications, the warranty will become void and field improvements may be denied.

---

Use of the Equipment Information page will help you identify your equipment in the case that you need to call your dealer or installer. This information should be filled out and kept on record.

### Equipment Information

Model Number: \_\_\_\_\_

Serial Number: \_\_\_\_\_

Date Purchased: \_\_\_\_\_

Dealer/Distributor Name and Phone Number:

\_\_\_\_\_  
\_\_\_\_\_  
\_\_\_\_\_  
\_\_\_\_\_

### Material Handling

1004 East Illinois Street  
Assumption, Illinois 62510 USA  
Phone: (217) 226-4421  
FAX: (800) 800-5329  
e-mail: [gsi@grainsystems.com](mailto:gsi@grainsystems.com)

---

# Table of Contents

Introduction .....	3
Equipment Information .....	4
Safety Guidelines .....	6
<b>Section 1 (<i>Getting Started</i>) .....</b>	<b>9</b>
General Guidelines .....	9
Safety Precautions/Site Considerations .....	10
Receiving Equipment .....	11
<b>Section 2 (<i>Back Panel Sub Assembly</i>) .....</b>	<b>12</b>
Back Panel Sub Assembly .....	12
Foreign Material Sub Assembly .....	13
Foreign Material Sub Assembly to Back Panel .....	14
Foreign Material Upper Sub Assembly .....	15
Foreign Material Upper Sub to Back Panel .....	16
By-Pass Pan Sub Assembly .....	17
By-Pass to Back Panel .....	18
<b>Section 3 (<i>Left Hand Side Panel Sub Assembly</i>) .....</b>	<b>19</b>
Fines Discharge Sub Assembly .....	19
Fines Chute Sub Assembly .....	20
Screened Discharge Sub Assembly .....	21
Left Hand Side Sub Assembly .....	22
Left Hand Panel to Back Panel .....	23
<b>Section 4 (<i>Right Hand Side Panel Sub Assembly</i>) .....</b>	<b>24</b>
Inlet Sub Assembly .....	24
Inlet Assembly .....	25
Gate Sub Assembly GST .....	26
Manual Gate Drive Sub Assembly .....	27
Right Hand Side Panel Sub Assembly .....	28
<b>Section 5 (<i>Front Panel Sub Assembly</i>) .....</b>	<b>29</b>
<b>Section 6 (<i>Final Assembly</i>) .....</b>	<b>30</b>

**NOTE**

All information, illustrations, photos, and specifications in this manual are based on the latest information available at the time of publication. The right is reserved to make changes at any time without notice.

# SAFETY GUIDELINES

This manual contains information that is important for you, the owner/operator, to know and understand. This information relates to protecting **personal safety** and **preventing equipment problems**. It is the responsibility of the owner/operator to inform anyone operating or working in the area of this equipment of these safety guidelines. To help you recognize this information, we use the symbols that are defined below.

Please read the manual and pay attention to these sections. Failure to read this manual and it's safety instructions is a misuse of the equipment and may lead to serious injury or death.



**This is the safety alert symbol. It is used to alert you to potential personal injury hazards. Obey all safety messages that follow this symbol to avoid possible injury or death.**



**DANGER** indicates an imminently hazardous situation which, if not avoided, will result in death or serious injury.



**WARNING** indicates a potentially hazardous situation which, if not avoided, could result in death or serious injury.



**CAUTION** indicates a potentially hazardous situation which, if not avoided, may result in minor or moderate injury.



**CAUTION** used without the safety alert symbol indicates a potentially hazardous situation which, if not avoided, may result in property damage.



**NOTE** indicates information about the equipment that you should pay special attention to.

## FOLLOW SAFETY INSTRUCTIONS

Carefully read all safety messages in this manual and on your machine safety signs. Keep signs in good condition. Replace missing or damaged safety signs. Be sure new equipment components and repair parts include the current safety signs. Replacement safety signs are available from the manufacturer.

Learn how to operate the machine and how to use controls properly. Do not let anyone operate without instruction.

Keep your machinery in proper working condition. Unauthorized modifications to the machine may impair the function and/or safety and affect machine life.

If you do not understand any part of this manual and need assistance, contact your dealer.

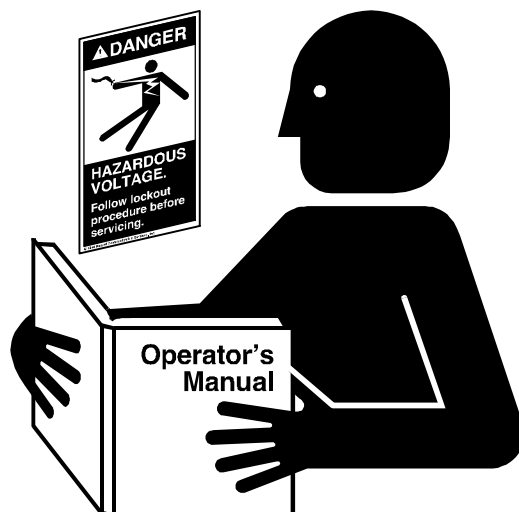

## STAY CLEAR OF HOISTED EQUIPMENT

Always use proper lifting/hoisting equipment when assembling or disassembling equipment.

Do not walk or stand under hoisted equipment.

Always use sturdy and stable supports when needed for installation.



## PRACTICE SAFE MAINTENANCE

Understand service procedures before doing work. Keep area clean and dry.

Never lubricate, service, or adjust machine while it is in operation. Keep hands, feet, and clothing from rotating parts.

Keep all parts in good condition and properly installed. Fix damage immediately. Replace worn or broken parts. Remove any build up grease, oil, or debris.



### PREPARE FOR EMERGENCIES

Be prepared if fire starts.

Keep a first aid kit and fire extinguisher handy.

Keep emergency numbers for doctors, ambulance service, hospital, and fire department near your telephone.

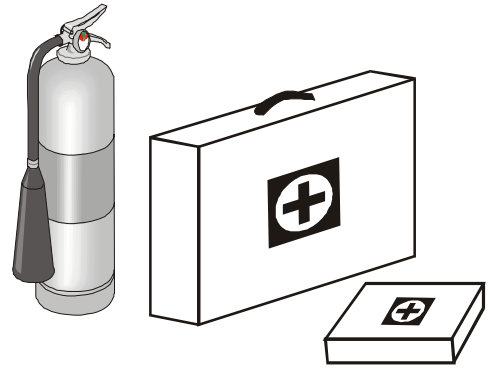

### WEAR PROTECTIVE CLOTHING

Wear close fitting clothing and safety equipment appropriate to the job.

Safety glasses should be worn at all times to protect eyes from debris.

Wear gloves to protect your hands from sharp edges on plastic or steel parts.

A respirator may be needed to help prevent breathing potentially toxic fumes and dust.

Wear hard hat and steel toe boots to help protect your head and toes from falling debris.

**Eye Protection**

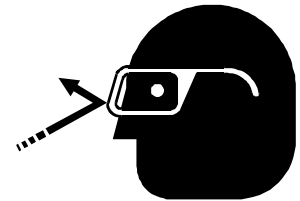

**Gloves**



**Steel Toe Boots**



**Respirator**



**Hard Hat**





## General Guidelines

It is important to identify what equipment has been installed to properly apply this information. This manual is intended to be used in conjunction with approved industry safety standards including, but not limited to, a properly implemented Lock Out/Tag Out Program.

While the nature of a Z-Flow is to remove oversized Foreign Material (FM) from the product stream. The specified capacity is conservatively based on an average product FM component, particle geometry, moisture content and properties. Specific considerations may enhance or hamper the performance and the operational practices suggested here may need to be modified to satisfy those conditions.

When incorporated into a system, it is important to understand the operation of this equipment and the effect that the operation of other equipment may have on the performance of the Z-Flow. These may include, but are not limited to, the situations listed:

1. Adequately sized equipment or spouting must be provided for the removal of product from the unit, including the removed FM. If conditions exist where the product discharge may become blocked, level indication should be considered, and steps should be taken to isolate the feed to the unit before a plugged condition can occur.

2. Where mechanical conveyance is used for the removal of oversized FM from the unit be certain to consider the properties of the material removed, and select a conveyor which is appropriate for the transport of such material.

3. Be certain that support structures are adequately sized for the operational and maximum loading conditions as well as meteorological, seismic and site related conditions.

4. Be certain to read all and understand all operating procedures prior to starting this equipment.

## Getting Started

A well organized plan for the Assembly and Installation of this equipment is essential for a safe and efficient project. Familiarize yourself with the information in this section prior to starting the assembly. This manual is provided for the convenience of the Assembler and is intended to be used at the site. It can be very helpful during the process to make notations in the manual. Additional manuals are available if replacements are required.

That assembly of this equipment can be accomplished safely and efficiently as detailed in this manual does not imply this is the only way to assemble this equipment, nor is it necessarily appropriate for all assembly situations. Use of good judgement and acceptable building practices is imperative for safe assembly.

If a component does not fit the installation, verify that the correct part has been identified. If an insurmountable problem is discovered with a component, contact the factory for advise or approval for modification.

## Safety Precautions

Read and understand all safety and assembly instructions prior to assembling this unit.

Material edges can be sharp, wear gloves when handling components.

Use proper safety equipment, protect employees at all times.

A clean and safe work area is essential.

Supplemental bracing is required during assembly.

Use appropriate and OSHA approved ladders and scaffolding where required.

Site conditions may require adaptation of these directions.

This is one possible method, and should not be construed as the only possible method, use reasonable judgement in the application of these directions.

## Site Considerations

A clean, level adequately sized concrete pad free of obstruction is ideal for assembly. If such conditions are unavailable, be sure to select an area with a firm surface which is relatively level, allowing safe access for construction equipment and future movement of the assembled unit. The site should provide access to the power requirements of the assembly tools. Electrical power should have integral Ground Fault protection.

If the unit is to be assembled inside an existing structure, be certain to comply with the Safety Regulations which exist for the facility. Additional support bracing, scaffolding and temporary bracing may be required to support loads induced through transporting and handling the equipment and cleaner components. Verify that existing floors and platforms can support the temporary loads placed upon them.

## Receiving the Equipment

*When the equipment arrives on site, find and retain the Bill of Materials (BOM), as they contain valuable part number information. In the Assembly Information, Part Lists will match the descriptions on the Bill of Materials.*

Inspect the shipment prior to unloading for damage which may have occurred during shipment. Inventory the material as it is unloaded and make notations in the unlikely event of a shortage or problem with the shipment. Preassembled Equipment must be

inspected for damage or loose fasteners caused by or during shipment.

Protect your investment in the unassembled components from damage or theft. If the components are to be stored for an extended period, inside storage is recommended. Galvanized coatings on stacked components can be damaged through prolonged exposure to wet environments, voiding the warranty on the coating. Replace the covers on shipping crates for added security.

---

## Preassembly of Equipment

These directions are intended to be all encompassing. Some assemblies may arrive completed from the factory, conditional upon shipping and other arrangements. It is ultimately the field assembler's responsibility to verify the completeness of the subassemblies at the time the unit is built.

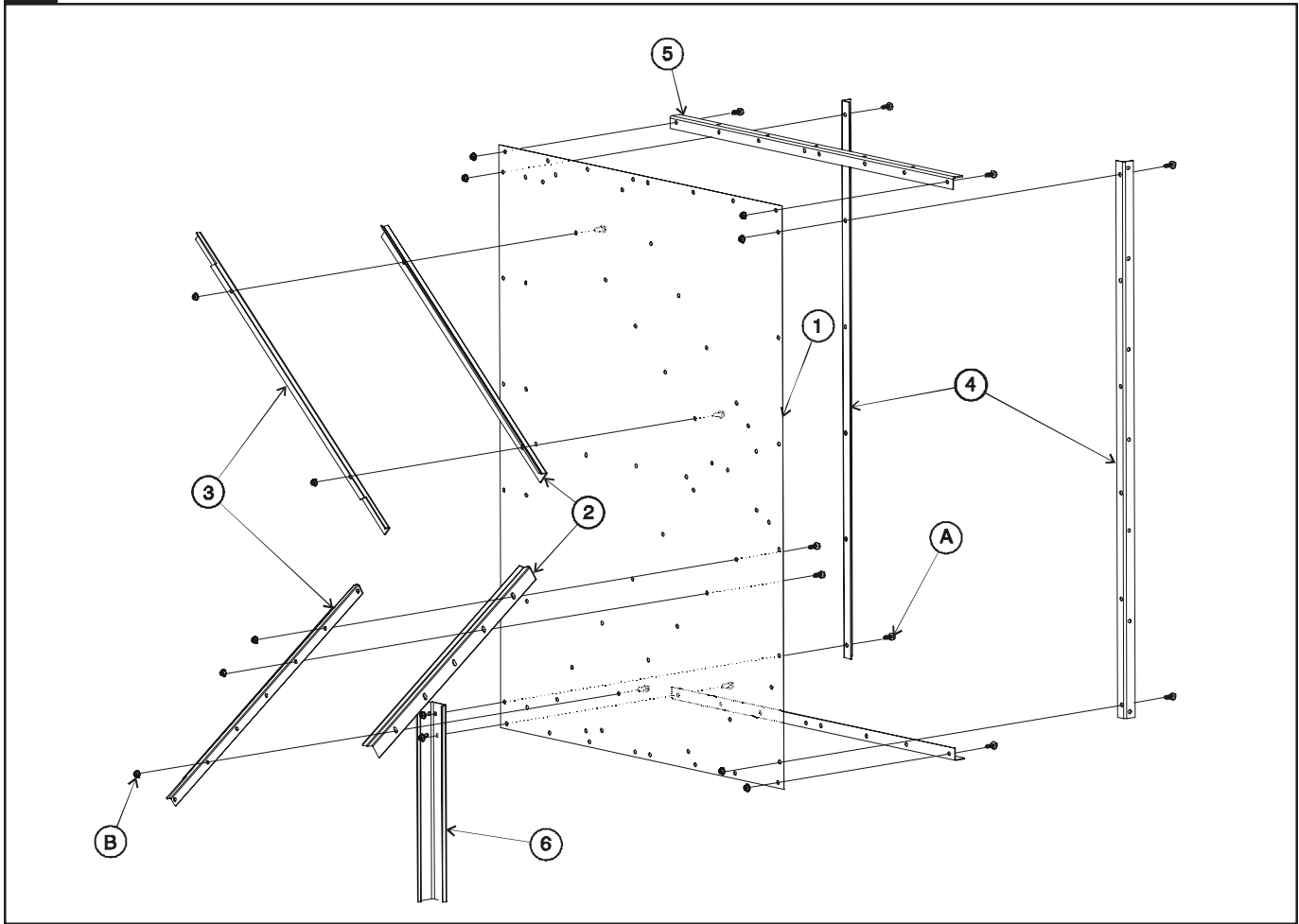

FIGURE 1

**Back Panel Sub Assembly**  
*(Refer to Figure 1 for hole alignment.)*

1. Insert a 3/8" x 1" HHCS Bolt through the front of the **Back Panel (1)**, then through the corresponding holes in the top and bottom **Runner Caps (2)** and **Screen Runners (3)**. Fasten using a 3/8" Whiz Nut.

2. Line up the holes in the **Side Flanges (4)** with the corresponding holes on the back side of the **Back Panel (1)**. Attach them together using 3/8" x 1" HHCS Bolts and a 3/8" Whiz Nuts.

**NOTE:** *The bottom left bolt will also go through the **Support Leg (6)** that is to be attached to the front side of the **Back Panel (1)**.*

3. Line up the holes in the **Top Flanges (5)** with the corresponding holes on the back side of the **Back Panel (1)**. Attach them together using 3/8" x 1" HHCS Bolts and a 3/8" Whiz Nuts.

**NOTE:** *The bottom left bolt will also go through the **Support Leg (6)** that is to be attached to the front side of the **Back Panel (1)**.*

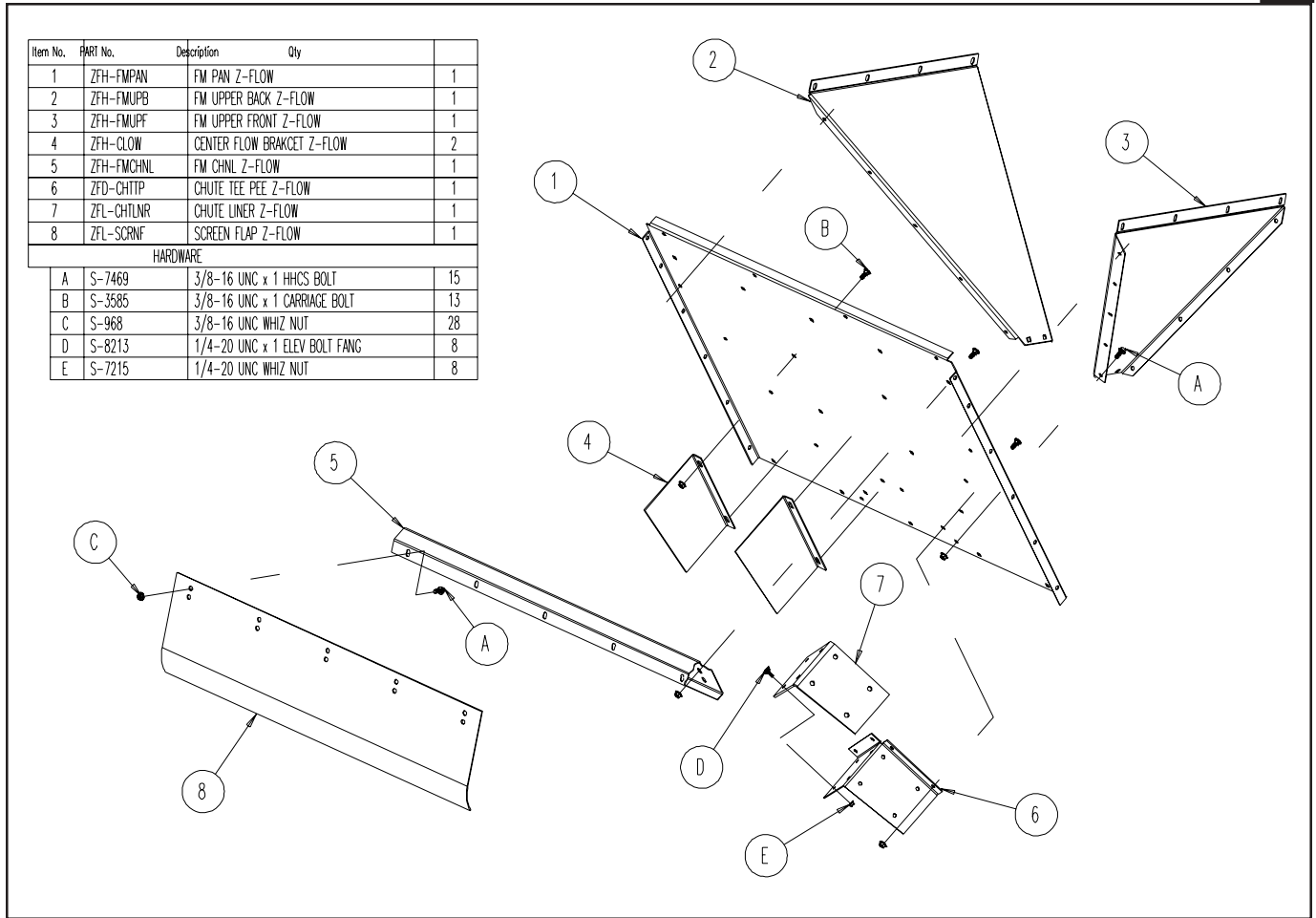

FIGURE 2

### Fm Pan Sub Assembly (Refer to Figure 1 for hole alignment.)

1. Line up holes and attach the **FM Upper Back (2)** and **FM Upper Front (3)** to the **FM Pan (1)** using 3/8" x 1" HHCS Bolts and Whiz Nuts.

2. Attach the **Center Flow Brackets (4)** to the center of the **FM Pan (1)** using 3/8" x 1" Carriage Bolts and Whiz Nuts.

3. Line up holes in the **Fm Channel (5)** with the corresponding hole using the **FM Pan (1)**. Fasten together using 3/8" x 1" HHCS Bolt and Whiz Nut.

4. Fasten the **Chute Liner (7)** to the outside of the **Chute Tee Pee (6)** using 1/4" x 1" Flanged Elevator Bolts and Whiz Nuts.

5. Attach **Chute Tee Pee (6)** to the **Fm Pan (1)** by lining up the holes and fastening together using 3/8" x 1" HHCS Bolts and Whiz Nuts.

6. To complete the sub-assembly, attach the **Screen Flap (8)** to the **Fm Channel (5)** using 3/8" x 1" Bolts and Whiz Nuts.

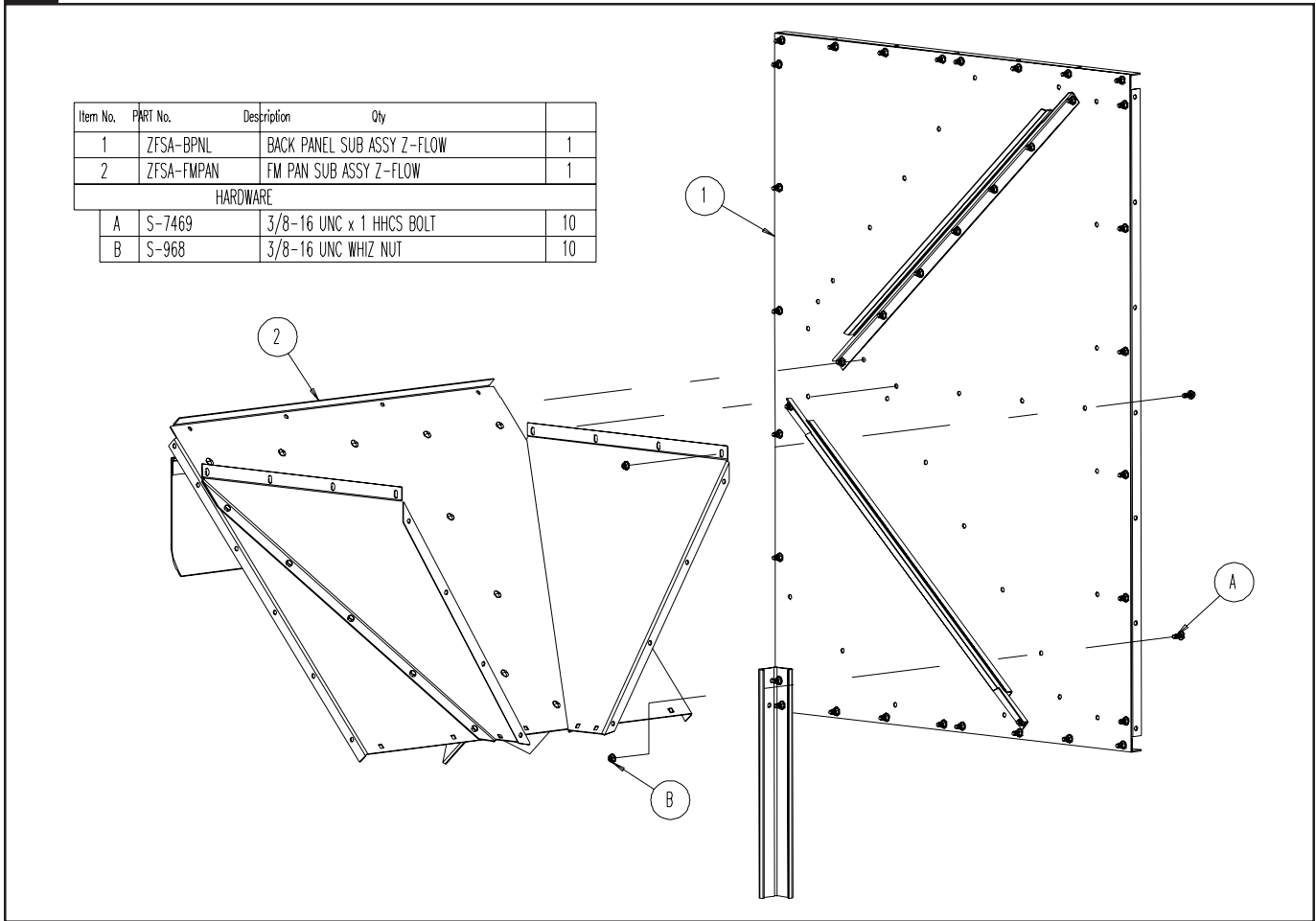

FIGURE 3

### Connecting Sub Assemblies (Refer to Figure 1 for hole alignment.)

1. You should have to complete assemblies created from instructions on page 1 & 2. Take the **Fm Pan Sub Assembly (2)** and attach it to the **Back Panel Sub Assembly (1)**. Line up the bolt holes as shown above and fasten together using 3/8" x 1" HHCS Bolts with Whiz Nuts.

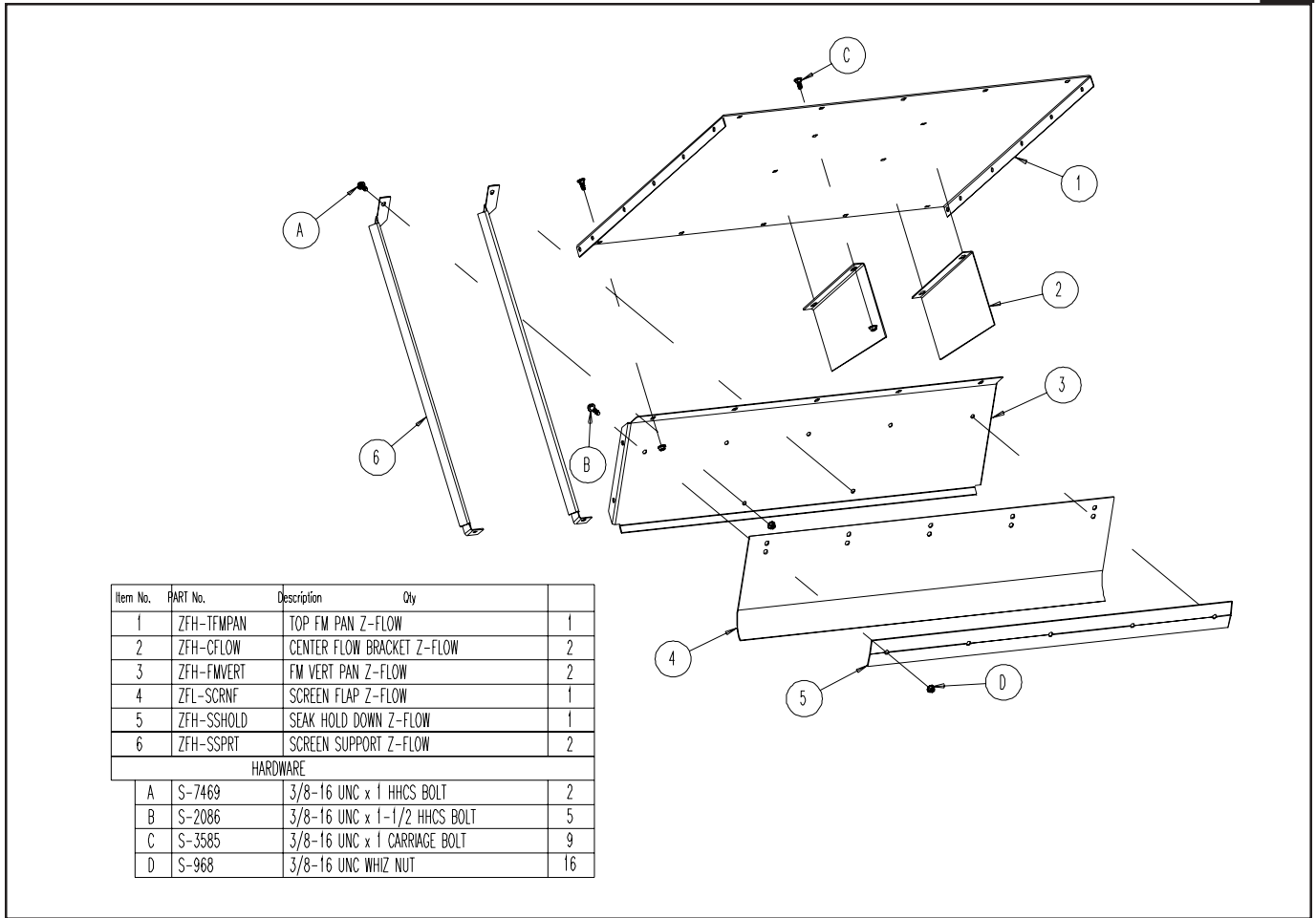

FIGURE 4

### Fm Upper Sub Assembly (Refer to Figure 4 for hole alignment.)

1. Attach the **Center Flow Brackets (2)** to the **Top Fm Pan (1)** using 3/8" x 1" Carriage Bolts with Whiz Nuts.
2. Line up the **FM Vertical Pan (3)** with the bottom row of holes on the **Top Fm Pan (1)** and fasten together using 3/8" x 1" Carriage Bolts and Whiz Nuts.
3. Fasten the **Screen Flap (4)** and ther **Seak Hold Down (5)** to the **Fm Vertical Pan (3)** using 3/8" x 1-1/2" HHCS Bolts with Whiz Nuts.
4. Attach the **Screen Supports (6)** to the **Fm Vertical Pan (3)** using 3/8" x 1" HHCS Bolts and Whiz Nuts.

## 2 Back Panel Sub Assembly

Item No.	PART No.	Description	Qty
1	ZFSA-FMUP	FM UPPER SUB ASSY GST Z-FLDW	
2	--	ZFSA-BPNL & ZFSA-FMPAN	1
HARDWARE			
A	S-7469	3/8-16 UNC x 1 HHCS BOLT	8
B	S-968	3/8-16 UNC WHIZ NUT	8

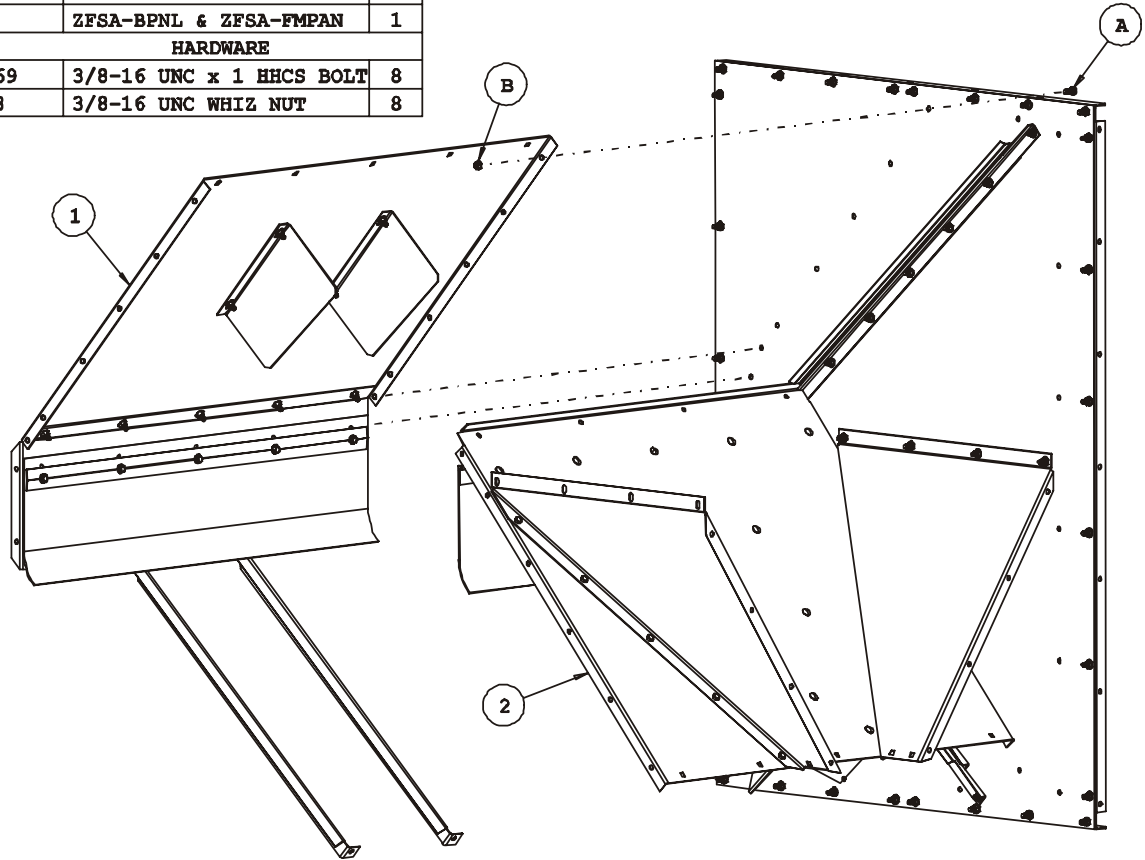

FIGURE 5

### Connecting Sub Assemblies (Refer to Figure 5 for hole alignment.)

1. Attach the **Fm Upper Sub Assembly (1)** to the **Back Panel & Fm Pan Sub Assembly (2)** using 3/8" x 1" HHCS Bolts and Whiz Nuts.



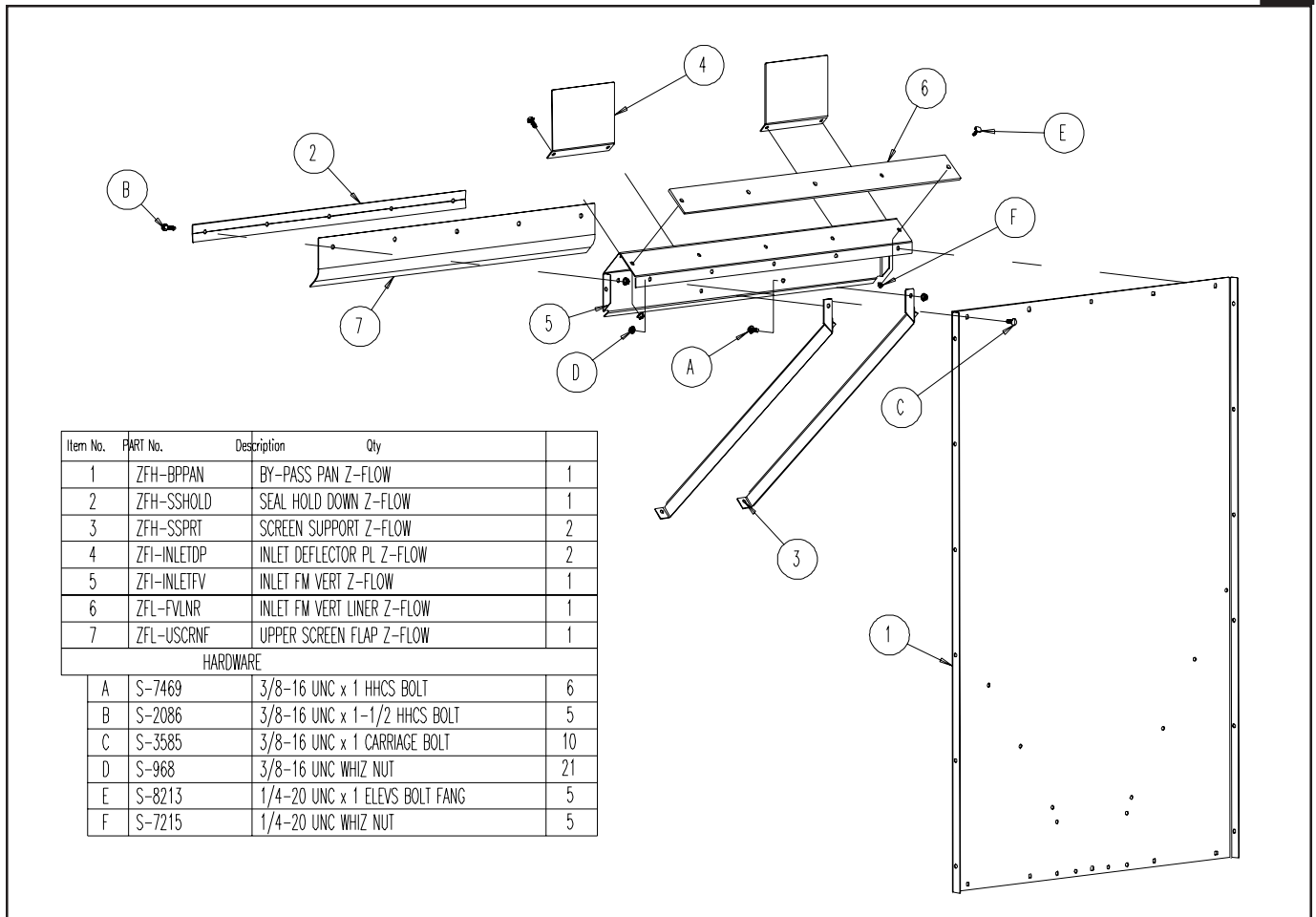

FIGURE 6

### By-Pass Pan Sub Assembly (Refer to Figure 6 for hole alignment.)

1. Line up holes in the **Seal Hold Down (2)**, **Upper Screen Flap (7)**, and the **Vertical Fm Inlet (5)** and fasten all three parts together using 3/8"x 1-1/2" HHCS Bolts and Whiz Nuts.
2. Attach the **Vertical Fm Inlet Liner (6)** to the **Vertical Fm Inlet (5)** using 1/4" x 1" Flanged Elevator Bolts with Whiz Nuts.
3. Fasten the **Inlet Deflectors (4)** to the **Vertical Fm Inlet (5)** with 3/8" x 1" HHCS Bolts and Whiz Nuts.
4. Next, attach the **Vertical Fm Inlet (5)** to the **By-Pass Pan (1)** using 3/8" x 1" Carriage Bolts and Whiz Nuts.
5. Finally, fasten the **Screen Supports (3)** to the **Vertical Fm Inlet (5)** using 3/8" x 1" HHCS Bolts and Whiz Nuts.

## 2 Back Panel Sub Assembly

Item No.	PART No.	Description	Qty
1	ZFSA-BPPAN	BY-PASS PAN SUB ASSY Z-FLOW	1
2	--	--	--
HARDWARE			
A	S-7469	3/8-16 UNC x 1 HHCS BOLT	7
B	S-968	3/8-16 UNC WHIZ NUT	7

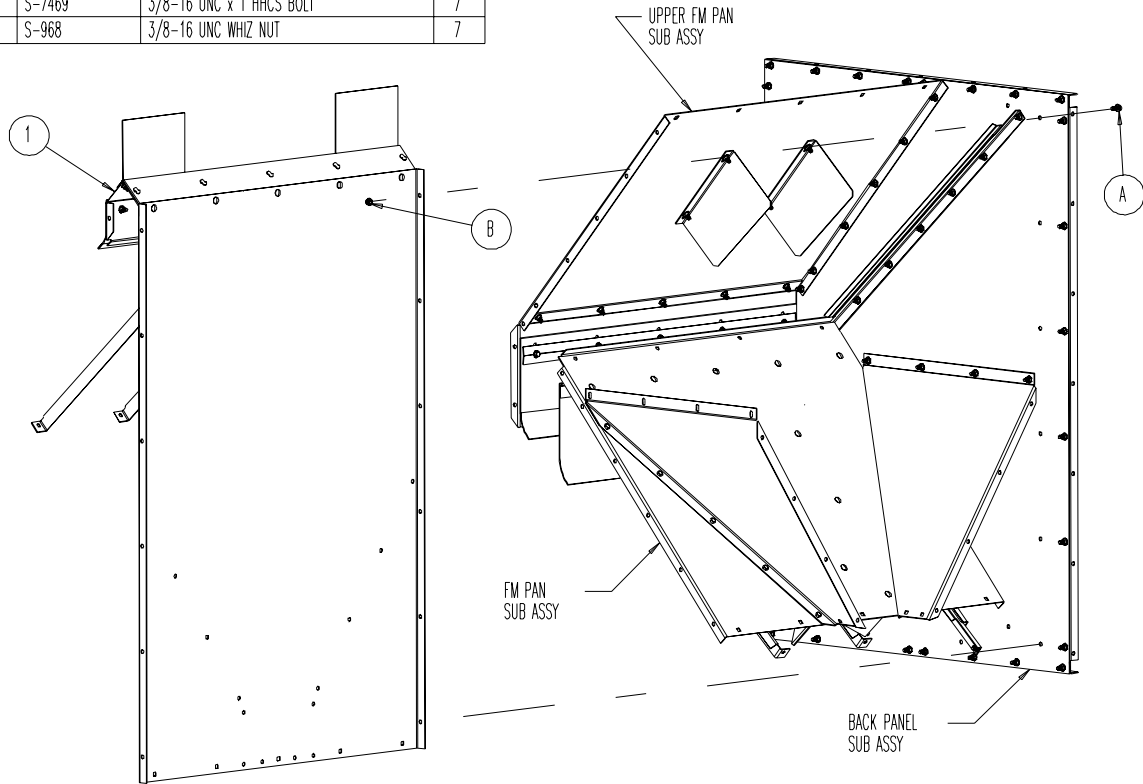

FIGURE 7

### Installing By-Pass Pan Sub Assembly

*(Refer to Figure 7 for hole alignment.)*

1. Attach the By-Pass Pan Sub Assembly (1) to the Back Panel Sub Assembly (2) as shown, using 3/8" x 1" HHCS Bolts and Whiz Nuts. The Upper Fm Pan Sub Assembly (3) and Fm Pan Sub Assembly (4) should already be attached to the Back Panel.

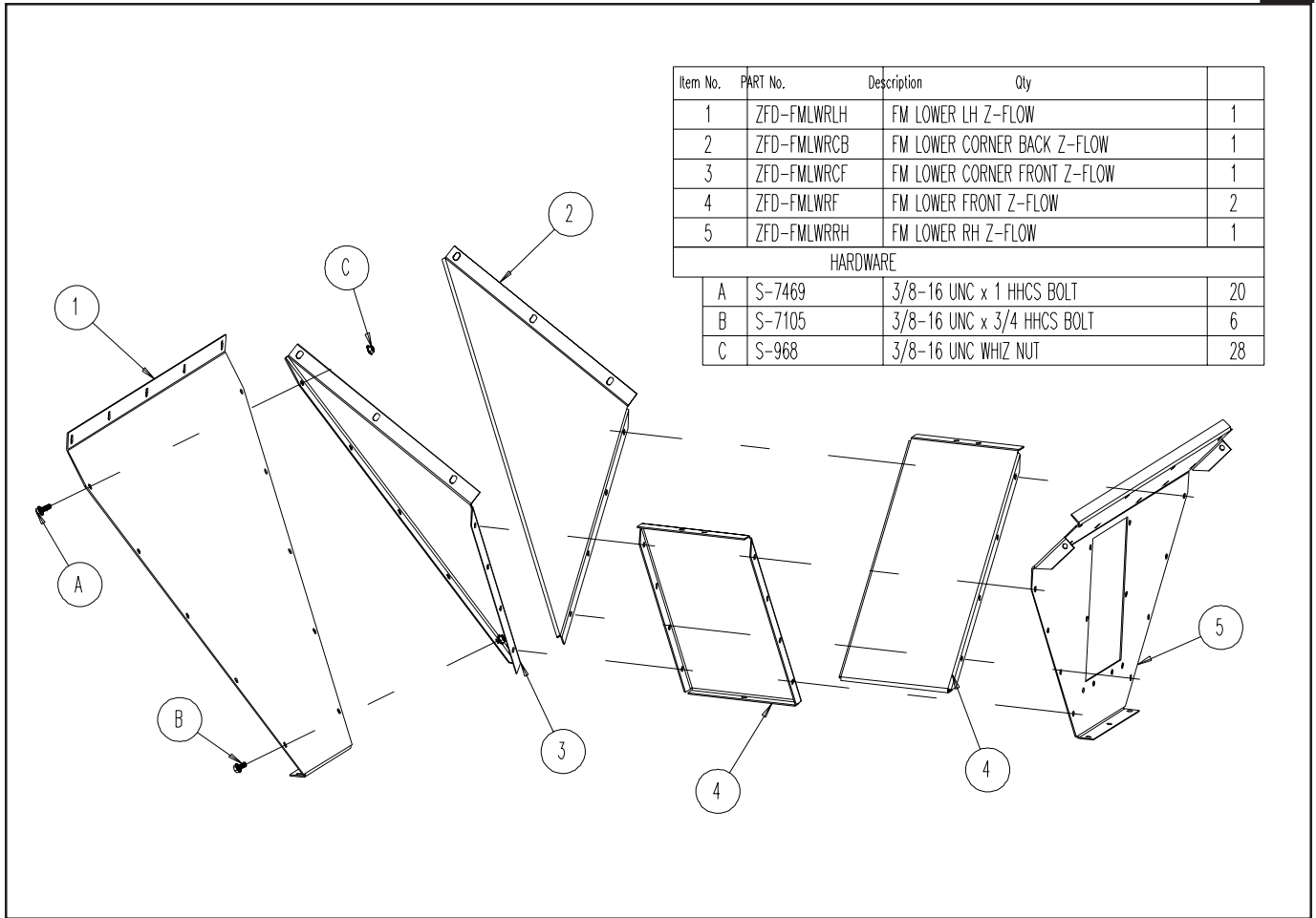

FIGURE 8

### Fines Discharge Sub Assembly (Refer to Figure 8 for hole alignment.)

1. Connect the FM Lower Fronts (4) to the FM Lower Right Hand (5) using 3/8" x 3/4" HHCS Bolts with Whiz Nuts.
2. Connect the Fm Lower Corner Front (3) and the Fm Lower Corner Back (2) to the Fm Lower Fronts (4) using 3/8" x 3/4" HHCS Bolts with Whiz Nuts.
3. Fasten together the FM Lower Left Hand (1) to the Fm Lower Corner Front (3) and the Fm Lower Corner Back (2) using 3/8" x 1" HHCS Bolts and Whiz Nuts.

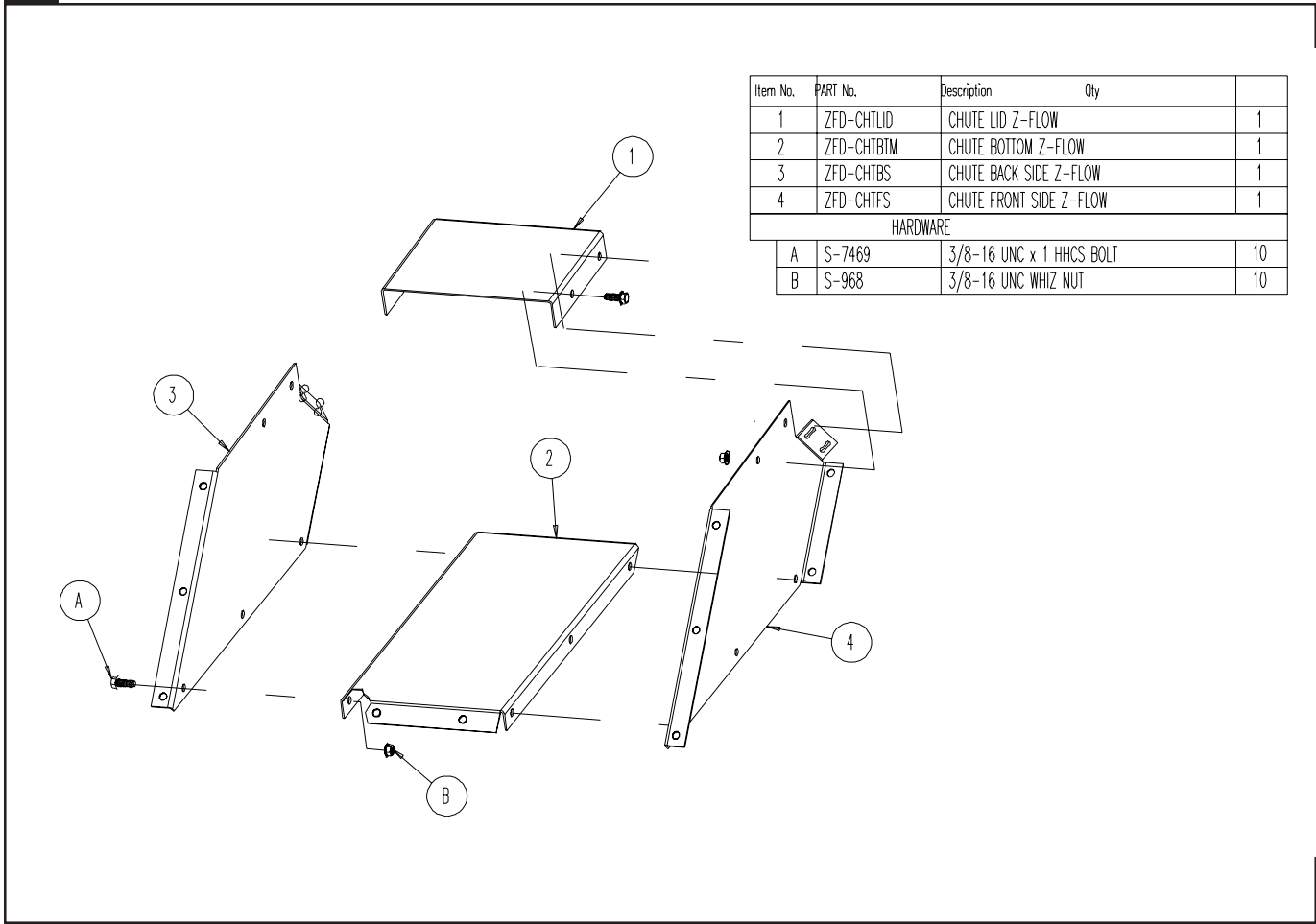

FIGURE 9

**Fines Chute Sub Assembly**  
*(Refer to Figure 9 for hole alignment.)*

1. Connect the Chute Back Side (3) to the Chute Bottom (2) using 3/8" x 1" HHCS Bolts and Whiz Nuts.
2. Attach the Chute Front Side (4) to the Chute Bottom (2) using 3/8" x 1" HHCS Bolts and Whiz Nuts.
3. Attach the Chute Lid (1) to both Chute Sides (3 & 4) using 3/8" x 1" HHCS Bolts and Whiz Nuts. *Note that the Chute Lid (1) Installs to the outside of the Chute Sides.*

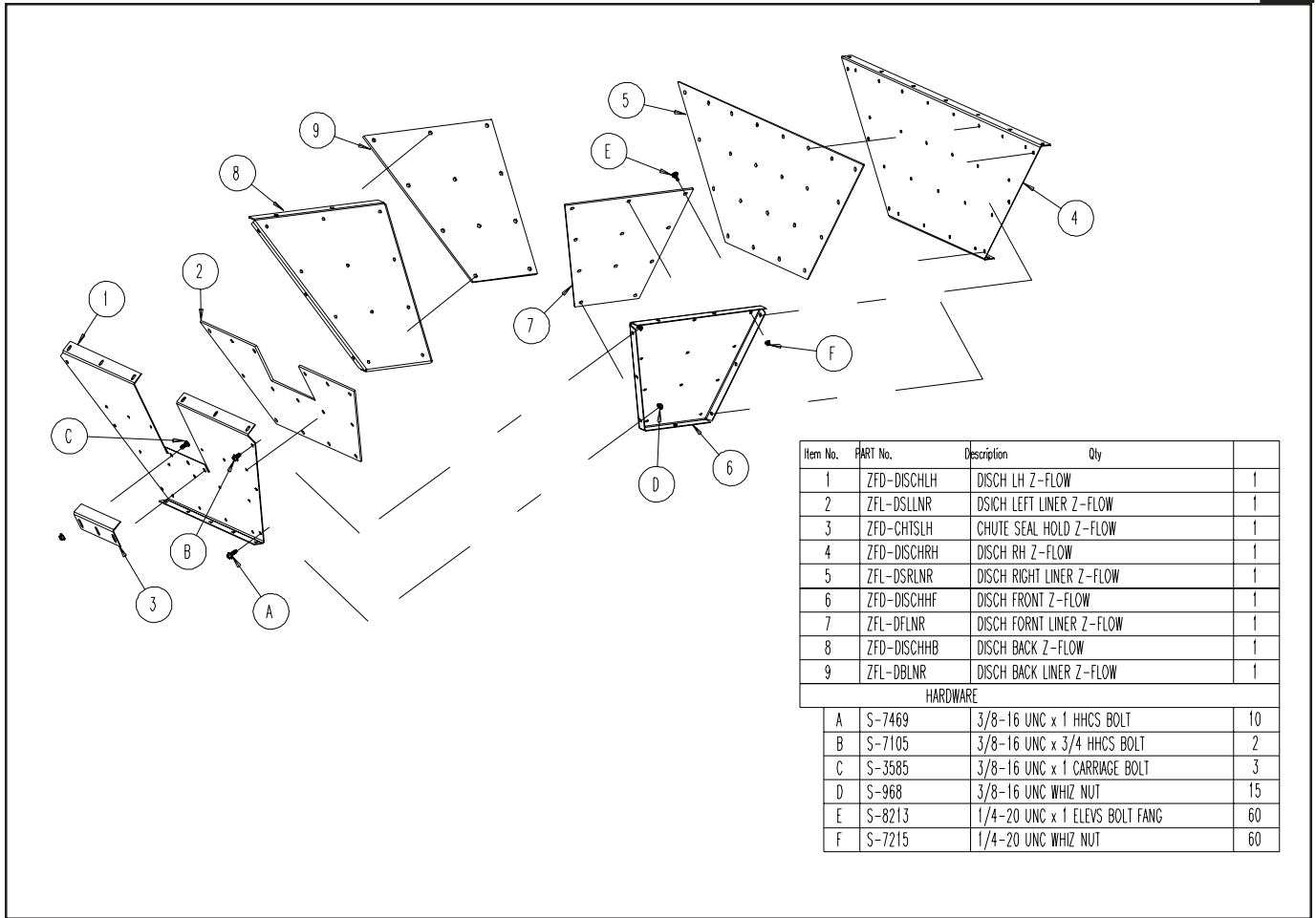

FIGURE 10

## Screened Discharge Sub Assembly

(Refer to Figure 10 for hole alignment.)

1. Insert 1/4" x 1" Flanged Elevator Bolts through the Discharge LH Liner (2) and the Discharge LH (1) fastening with a 1/4" Whiz Nuts.

2. Insert 1/4" x 1" Flanged Elevator Bolts through the Discharge Front Liner (7) and the Discharge Front (6) fastening with a 1/4" Whiz Nuts.

3. Insert 1/4" x 1" Flanged Elevator Bolts through the Discharge Back Liner (9) and the Discharge Back (8) fastening with a 1/4" Whiz Nuts.

4. Insert 1/4" x 1" Flanged Elevator Bolts through the Discharge Right Liner (5) and the

Discharge Right Hand (4) fastening with a 1/4" Whiz Nuts.

5. Attach the Discharge Left & Right Hand Sides (1 & 4) to the Discharge Front (6) using 3/8" x 1" HHCS Bolts and Whiz Nuts.

6. Attach the Discharge Back (8) to the Discharge Left & Right Hand Sides (1 & 4) using 3/8" x 1" HHCS Bolts and Whiz Nuts.

7. Attach the Chute Seal Hold (3) to the Discharge LH (1) using 3/8" x 1" Carriage Bolts and Whiz Nuts. *Note: Insert bolts through the inside of the Discharge LH (1).*

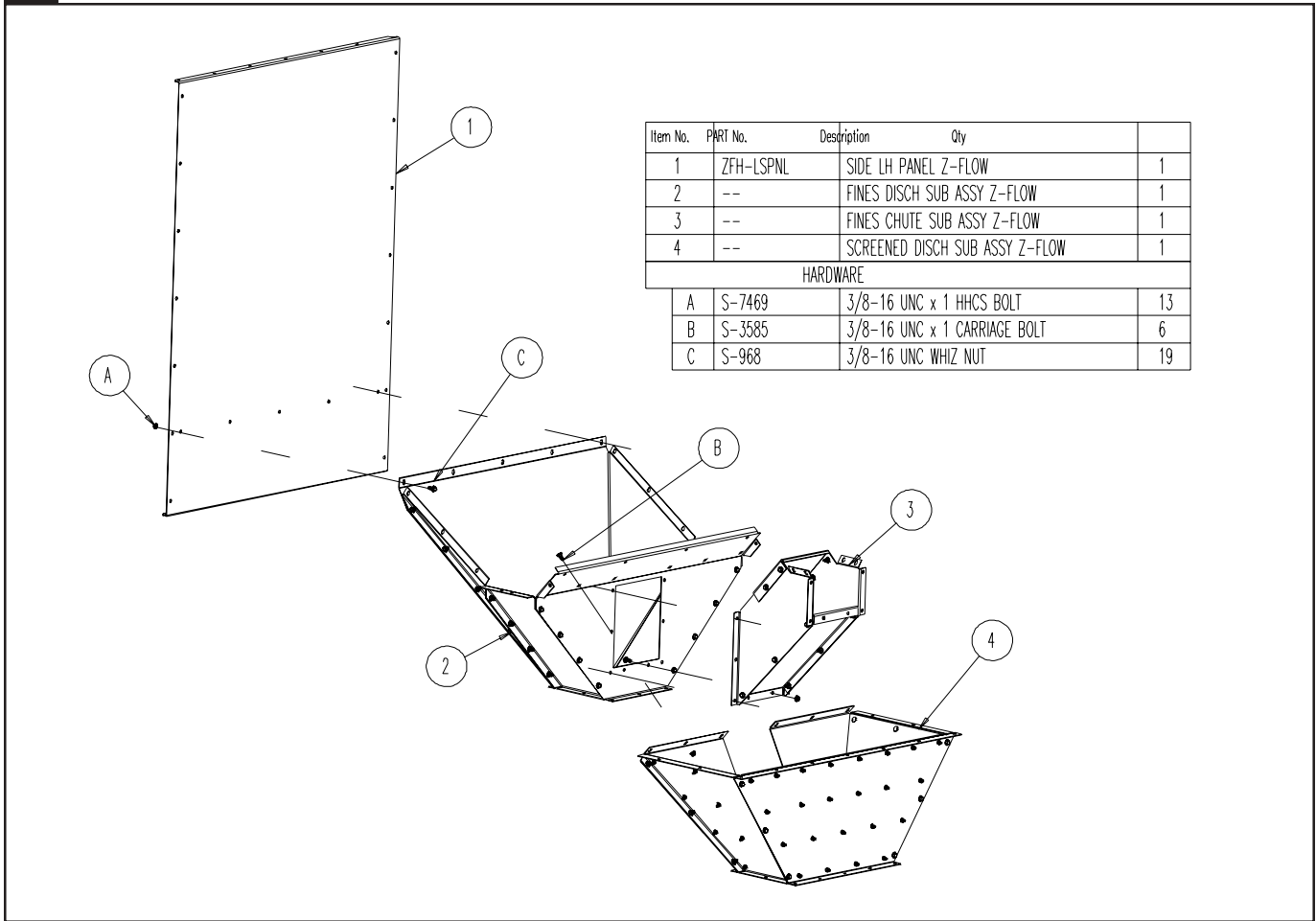

FIGURE 11

### Installing LH Side Panel Sub Assemblies

(Refer to Figure 11 for hole alignment.)

1. Install the fines Discharge Sub Assembly (2) to the LH Side Panel (1) with 3/8" x 1" HHCS Bolts & Whiz Nuts.
2. Attach the Fines Chute Sub Assembly (3) to the Fines Discharge Sub Assembly (2) using 3/8" x 1" HHCS Bolts & Whiz Nuts.
3. Then connect the Screened Discharge Sub Assembly (4) to the Fines Discharge Sub Assembly (2) using 3/8" x 1" Carraige Bolts & Whiz Nuts. *Note: Insert the Carraige Bolts through the Fines Discharge (2) first, then through the Screened Discharge (4).*

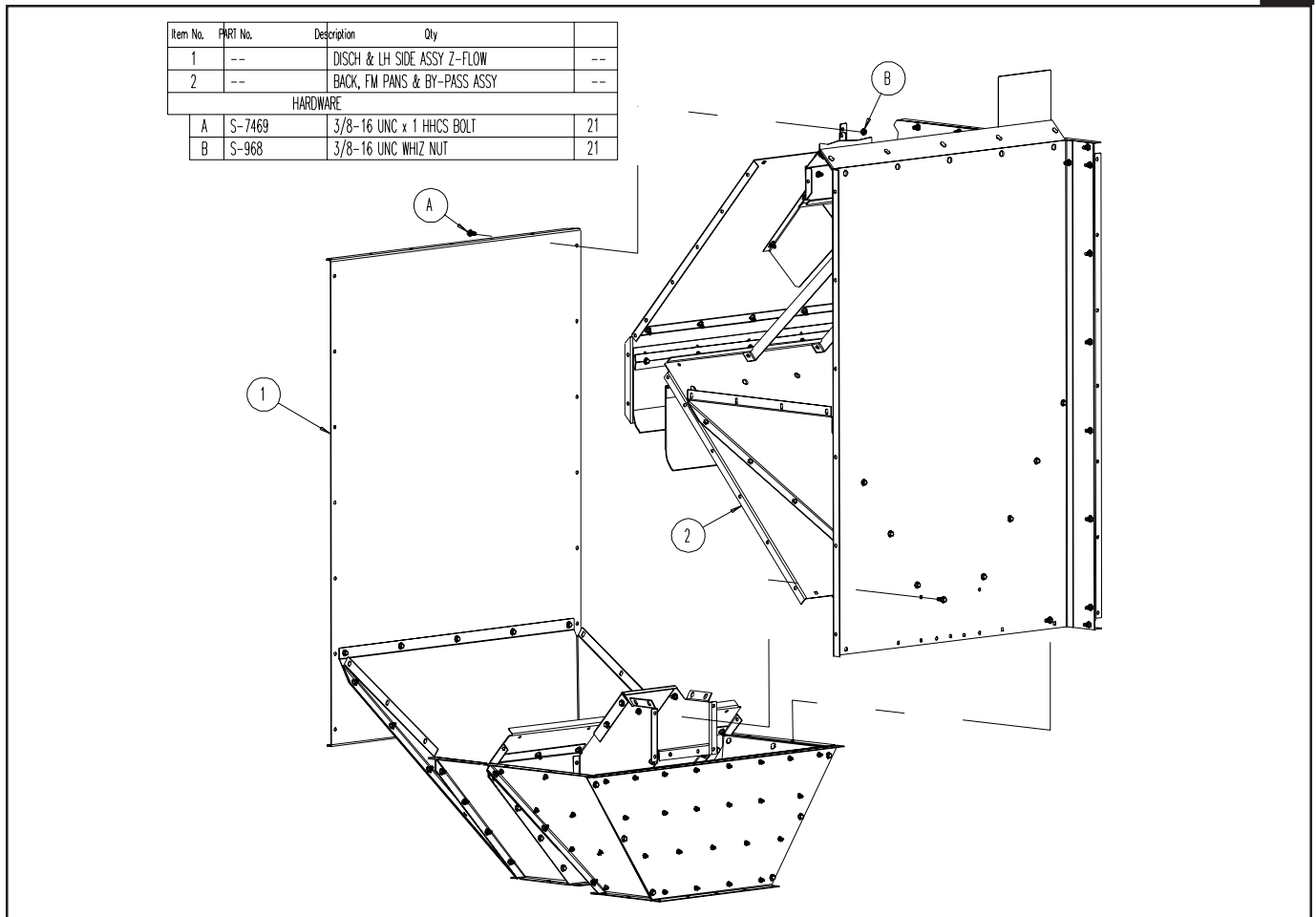

FIGURE 12

### Installing the Assemblies (Refer to Figure 12 for hole alignment.)

1. Attach the Discharge & LH Side Assembly (1) to the Back, Fm Panel, & By-Pass assembly (2) to together using 3/8" x 1" HHCS Bolts and Whiz Nuts.

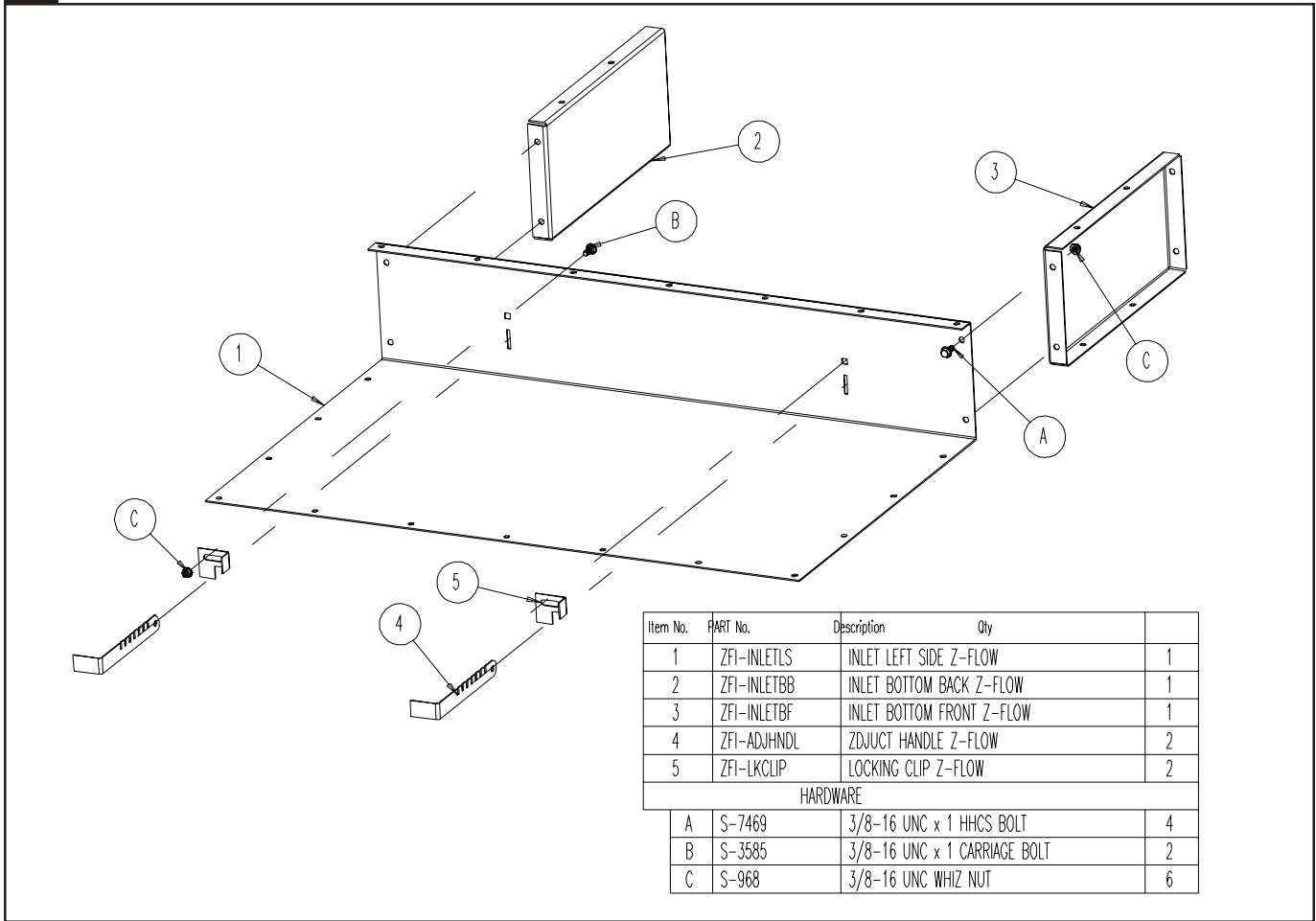

FIGURE 13

### Inlet Sub Assembly

(Refer to Figure 13 for hole alignment.)

1. Insert 3/8" x 1" Carriage Bolts through the Inlet Left Side (1) and then through the Locking Clips (5). Use 3/8" Whiz Nuts to fasten together, but do not fully tighten so Locking Clips (5) can be slid into the Junction Handles (4).
2. Insert ZD Junction Handles (4) into slot on the Inlet Left Side (1). Lock into place by sliding the Locking Clips (5) into a slot on the handle.
3. Attach the Inlet Bottom Back (2) and Inlet Bottom Front (3) to the Inlet Left Side (1) using 3/8" x 1" HHCS Bolts and Whiz Nuts.



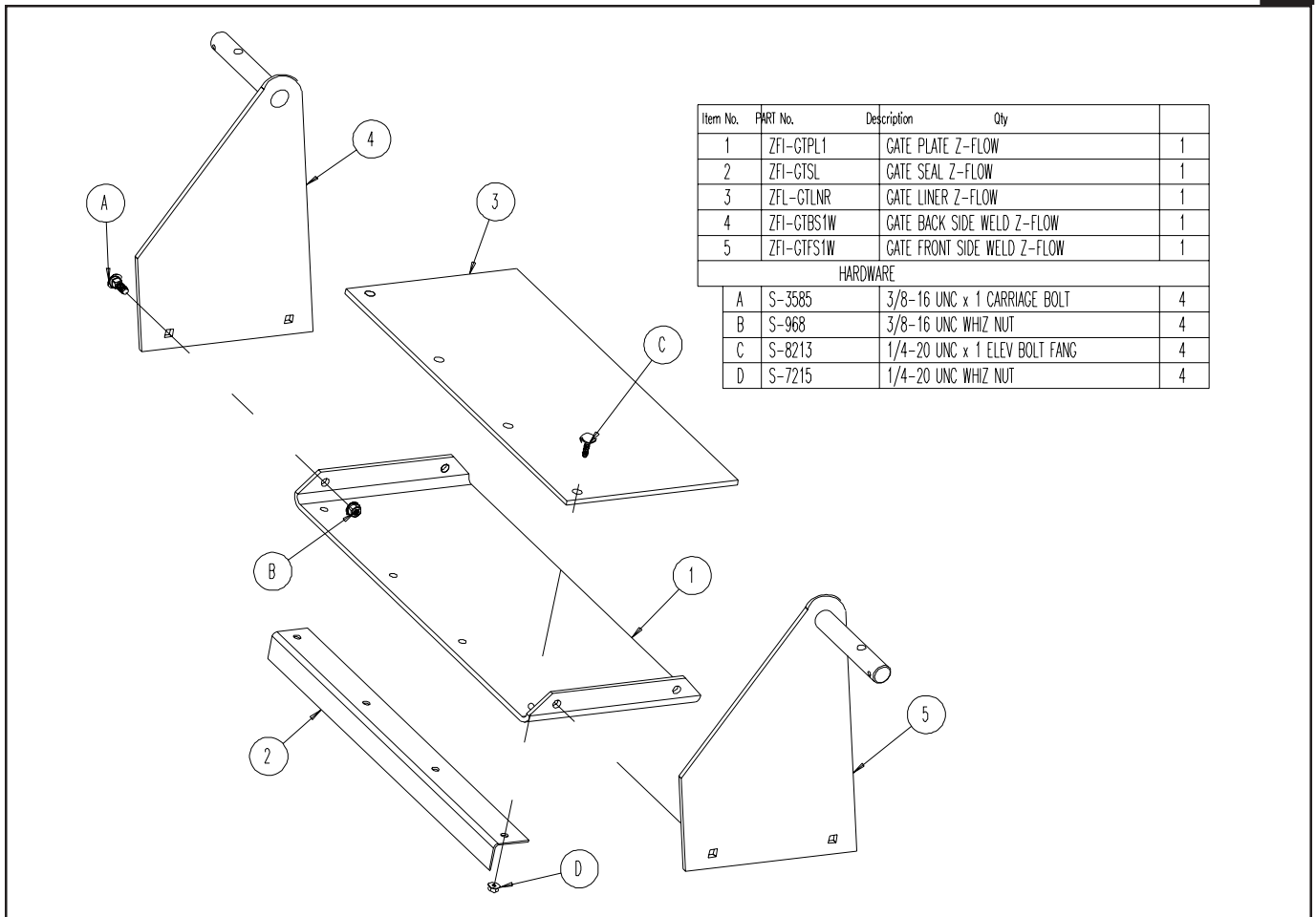

FIGURE 14

## Gate Sub Assembly

*(Refer to Figure 14 for hole alignment.)*

1. Insert the 1/4" x 1" Flanged Elevator Bolts through the Gate Liner (3), the Gate Plate (1), and then through the Gate Seal (2). Fasten together with 1/4" Whiz Nuts.

2. Attach the Gate Back Side Weldment (4) and the Gate Front Side Weldment (5) to the sides of the Gate Plate (1) using 3/8" x 1" Carriage Bolts and Whiz Nuts.

## 4 Right Hand Side Panel Sub Assembly

Item No.	PART No.	Description	Qty
1	ZFI-INFLCL	INLET FLANGE LEFT Z-FLOW	1
2	ZFI-INLETFB	INLET FLANGE BACK Z-FLOW	1
3	ZFI-INLETFR	INLET FLANGE FRONT Z-FLOW	1
4	ZFI-INLETRS	INLET RIGHT SIDE Z-FLOW	1
5	ZFI-SCLTOP	INLET TOP SINGLE Z-FLOW	1
6	ZFI-SPRDPL	INLET SPREADER PL Z-FLOW	1
7	ZFH-HINGE	HINGE BRACKET Z-FLOW	1
8	ZFL-SPRDLNR	SPREADER PL LINER Z-FLOW	1
9	ZFL-INRLNR	INLET RIGHT LINER Z-FLOW	1
10	ZFI-SBSH	SHAFT BUSHING Z-FLOW	2
11	ZFSA-GATE	GATE SUB ASSY Z-FLOW	1

HARDWARE			
Item No.	PART No.	Description	Qty
A	S-7469	3/8-16 UNC x 1 HHCS BOLT	39
B	S-2086	3/8-16 UNC x 1-1/2 HHCS BOLT	2
C	S-968	3/8-16 UNC WHIZ NUT	43
D	S-6998	1/4-20 UNC x 1 HHCS BOLT	8
E	S-8213	1/4-20 UNC x 1 ELEV BOLT FANG	30
F	S-7215	1/4-20 UNC WHIZ NUT	38

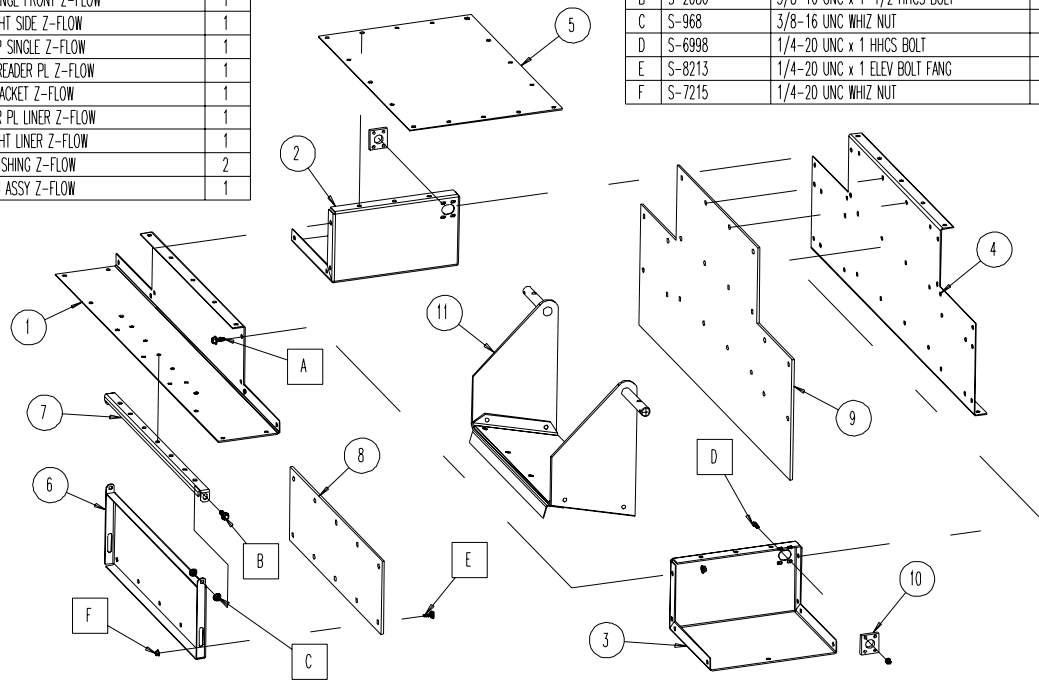

FIGURE 15

### Gate Sub Assembly GST (Refer to Figure 15 for hole alignment.)

1. Attach the Inlet Right Liner (9) to the Inlet Right Side (4) and the Spreader PL Liner (8) to the Inlet Spreader PL (6) using 1/4" x 1" Flanged Elevator Bolts and Whiz Nuts. **Note:** Bolt heads should rest against the Liners.
2. Attach the Shaft Bushings (10) to the Inlet Flange Front (3) and Back (2) using 1/4" x 1" HHCS Bolts with Whaz Nuts. Slide the inlet flanges (2 & 3) onto the Gate Sub Assembly (11). Then attach the Inlet Top Single (5) to the Inlet Flanges (2 & 3) using 3/8" x 1" HHCS Bolts with Whiz Nuts.
3. Fasten the Inlet Right Side (4) to the Inlet Flanges (2 & 3) using 3/8" x 1" HHCS Bolts with Whiz Nuts.
4. Attach the Hinge Bracket (7) to the Inlet Flange Left (1) 3/8" x 1" HHCS Bolts with Whiz Nuts.
5. Install a 3/8" x 1-1/2" HHCS Bolt through the end of the Hinge Bracket (7) then fasten on a Whiz Nut, then pass bolt through the Inlet Spreader PL (6) and fasten with another Whiz Nut. Repeat same procedure for other end.
6. Complete sub assembly by connecting Inlet Flange Left (1) to the Inlet Flanges (2 & 3) using 3/8" x 1" HHCS Bolts with Whiz Nuts.

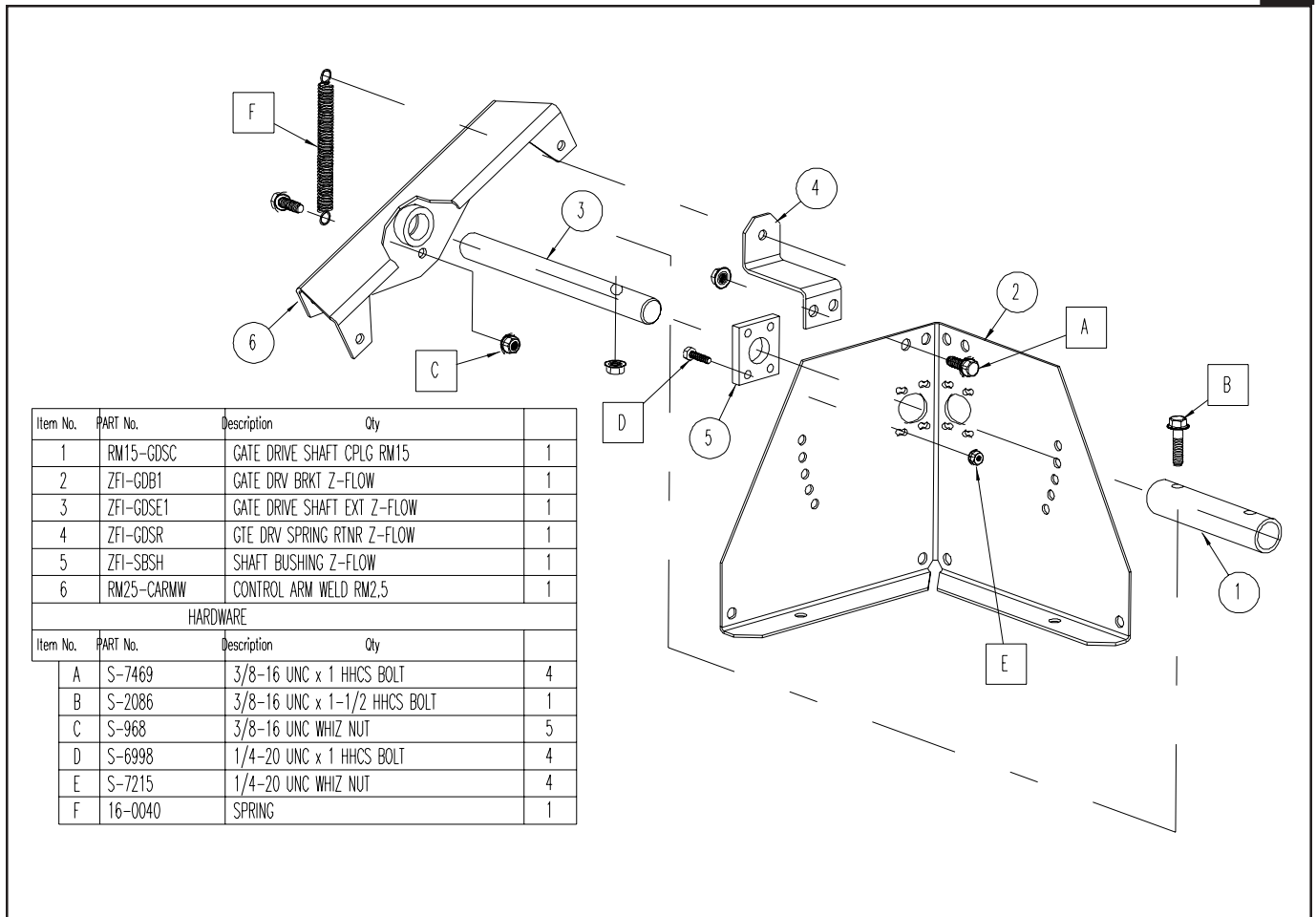

FIGURE 16

## Manual Gate Drive Sub Assembly

**(Refer to Figure 16 for hole alignment.)**

1. Attach Shaft Bushing (5) to Gate Drive Bracket (2) using 1/4" x 1" HHCS Bolts with Whiz Nuts.
2. Fasten the Gate Drive Spring Retainer (4) to the Gate Drive Bracket (2) using 3/8" x 1" HHCS Bolts and Whiz Nuts.
3. Insert Gate Drive Shaft Extension (3) through the Shaft Bushing (5) and Gate Drive Bracket (2) and into the Gate Drive Shaft. Line up the holes in the Gate Drive Shaft (1) and Gate Drive Shaft Extension (3).
4. Slide Control Arm Weldment (6) onto the Gate Drive Shaft Extension (3).

5. Attach the Spring Somehow that makes sense.

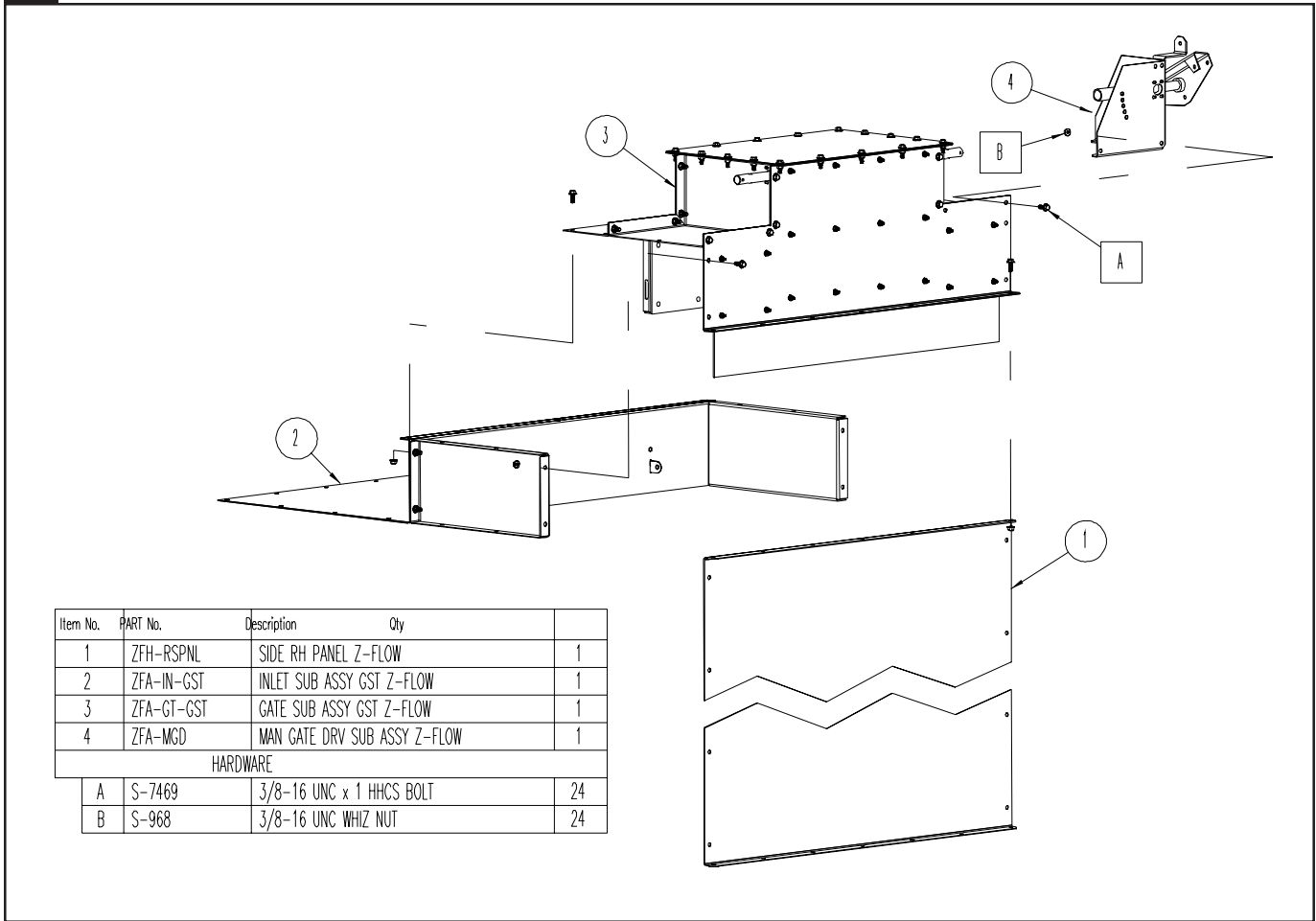

FIGURE 17

## Right Hand Side Panel Sub Assembly

(Refer to Figure 17 for hole alignment.)

1. Attach the Inlet Sub Assembly (2) to the Gate Sub Assembly (3) as shown using 3/8" x 1" HHCS Bolts and Whiz Nuts.
2. Slide the Manual Gate Drive Sub Assembly (4) onto the shaft of the Gate Sub Assembly (3) and attach to the top using 3/8" x 1" HHCS Bolts and Whiz Nuts. Bolt Shafts together using ??
3. Attach Right Hand Side Panel (1) to the Gate Sub Assembly (3) as shown using 3/8" x 1" HHCS Bolts and Whiz Nuts.

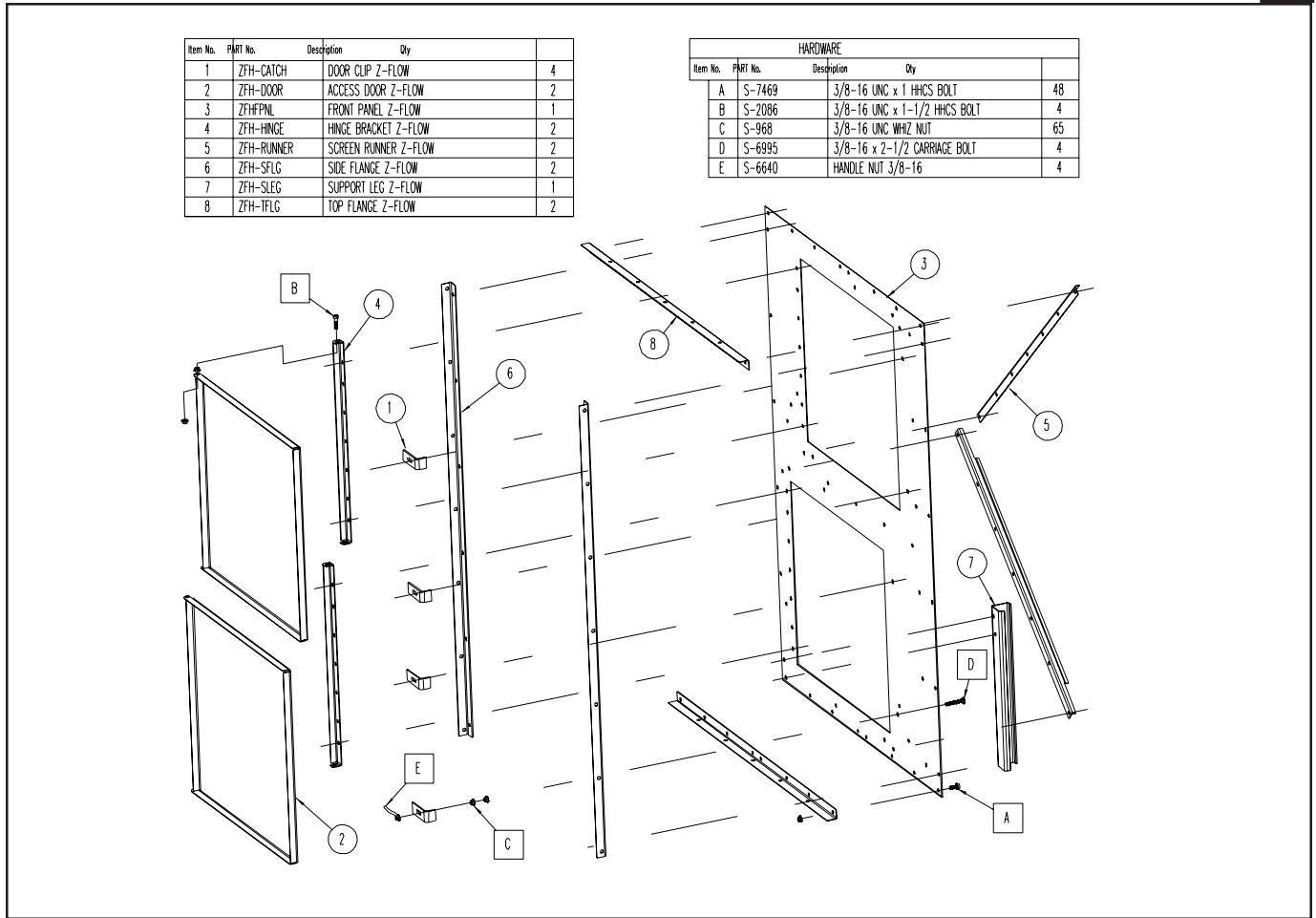

FIGURE 18

## Front Panel Sub Assembly

*(Refer to Figure 18 for hole alignment.)*

1. Install the top Top Flange (8) and the top Screen Runner (5) at the same time because they share a common bolt. The Top Flange (8) will install to the front of the Front Panel (3) and the Screen Runner (5) to the back of the Front Panel. Use 3/8" x 1" HHCS Bolts with Whiz Nuts to fasten together.

2. Install the Left Side Flange (6), the bottom Top Flange (8) and the Support Leg (7) at the same time because they share common bolts. Attach the Side Flange (6) to the front side of the Front Panel (3) and Support Leg (7) to the back bottom left of the panel using the same bolt. Now, attach the bottom Top Flange (8) to the bottom of the Front Panel (3) and place bottom left bolt through both the Flange and

the Support Leg (7). Use 3/8" x 1" HHCS Bolts and Whiz Nuts.

3. Attach the right Side Flange (6) to the Front Panel (3) using 3/8" x 1" HHCS Bolts and Whiz Nuts. Attach the Screen Runner (5) across the back of the Front Panel (3) using 3/8" x 1" HHCS Bolts and Whiz Nuts.

4. Attach the Hinge Brackets (4) to the Front Panel (3) using 3/8" x 1" HHCS Bolts and Whiz Nuts. Fasten Access Doors (2) to the Hinge Brackets (4) using 3/8" x 1-1/2" HHCS Bolts. Place the bolts through the Hinge Brackets (4), fasten on a Whiz Nut backwards, then pass bolt through the Access Door (2) and fasten with a Whiz Nut.

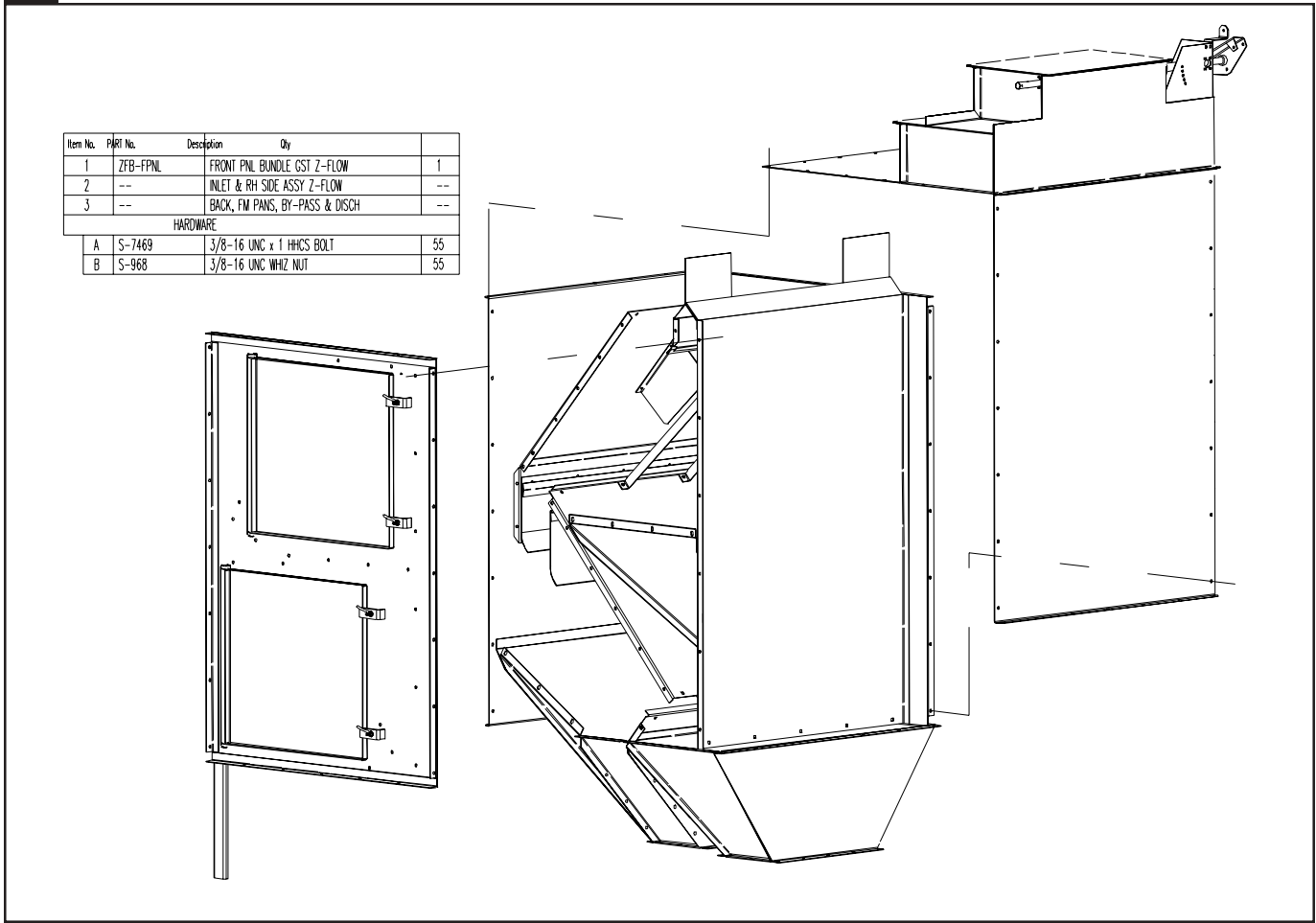

FIGURE 19

## Final Assembly

*(Refer to Figure 19 for hole alignment.)*

1. Connect the Front Panel Bundle (1) to the Back, Fm Pans, By-Pass, & Discharge Assembly (3) using 3/8" x 1" HHCS Bolts and Whiz Nuts.
  
2. Attach the Inlet & RH Side Assembly (2) to the Back, FM Pans, By-Pass, & Discharge Assembly (3) using 3/8" x 1" HHCS Bolts and Whiz Nuts.

# WARRANTY

THE COMPANY WARRANTS ALL PRODUCTS MANUFACTURED TO BE FREE OF DEFECTS IN MATERIAL AND WORKMANSHIP UNDER NORMAL USAGE AND CONDITIONS FOR A PERIOD OF TWELVE (12) MONTHS AFTER RETAIL SALE TO THE ORIGINAL END USER OF SUCH PRODUCTS. OUR ONLY OBLIGATION IS, AND PURCHASER'S SOLE REMEDY SHALL BE TO REPAIR OR REPLACE, AT THE COMPANY'S OPTION AND EXPENSE, PRODUCTS THAT, IN THE MANUFACTURERS SOLE JUDGEMENT, CONTAIN A MATERIAL DEFECT DUE TO MATERIALS OR WORKMANSHIP. ALL DELIVERY AND SHIPMENT CHARGES TO AND FROM THE FACTORY WILL BE PURCHASER'S RESPONSIBILITY. EXPENSES INCURRED BY OR ON BEHALF OF THE PURCHASER WITHOUT PRIOR WRITTEN AUTHORIZATION FROM AN AUTHORIZED EMPLOYEE OF THE COMPANY SHALL BE THE SOLE RESPONSIBILITY OF THE PURCHASER.

EXCEPT FOR THE ABOVE EXPRESS LIMITED WARRANTIES, THE COMPANY MAKES NO WARRANTY OF ANY KIND, EXPRESSED OR IMPLIED, INCLUDING, WITHOUT LIMITATION, WARRANTIES OF MERCHANTABILITY OR FITNESS FOR A PARTICULAR PURPOSE OR USE IN CONNECTION WITH (i) PRODUCT MANUFACTURED OR SOLD BY THE COMPANY OR (ii) ANY ADVICE, INSTRUCTION, RECOMMENDATION OR SUGGESTION PROVIDED BY AN AGENT, REPRESENTATIVE OR EMPLOYEE OF THE COMPANY REGARDING OR RELATED TO THE CONFIGURATION, INSTALLATION, LAYOUT, SUITABILITY FOR A PARTICULAR PURPOSE, OR DESIGN OF SUCH PRODUCT OR PRODUCTS.

IN NO EVENT SHALL THE COMPANY BE LIABLE FOR ANY DIRECT, INDIRECT, INCIDENTAL, OR CONSEQUENTIAL DAMAGES, INCLUDING, WITHOUT LIMITATION, LOSS OF ANTICIPATED PROFITS OR BENEFITS. PURCHASER'S SOLE AND EXCLUSIVE REMEDY SHALL BE LIMITED TO THAT STATED ABOVE, WHICH SHALL NOT EXCEED THE AMOUNT PAID FOR THE PRODUCT PURCHASED. THIS WARRANTY IS NOT TRANSFERABLE AND APPLIES ONLY TO THE ORIGINAL PURCHASER. WE SHALL HAVE NO OBLIGATION OR RESPONSIBILITY FOR ANY REPRESENTATIVE OR WARRANTIES MADE BY OR ON BEHALF OF ANY DEALER, AGENT OR DISTRIBUTOR OF THE COMPANY.

THE COMPANY ASSUMES NO RESPONSIBILITY FOR FIELD MODIFICATIONS. MODIFICATIONS TO THE PRODUCT NOT SPECIFICALLY COVERED BY THE CONTENTS OF THIS MANUAL WILL NULLIFY ANY PRODUCT WARRANTY THAT MIGHT HAVE BEEN OTHERWISE AVAILABLE. THE USE OF OUR EQUIPMENT TO HANDLE MATERIALS OTHER THAN FREE FLOWING, NONABRASIVE AND DRY MATERIALS, AS INTENDED, WILL RESULT IN THE VOIDING OF THIS LIMITED WARRANTY.

THE FOREGOING WARRANTY SHALL NOT COVER PRODUCTS OR PARTS WHICH HAVE BEEN DAMAGED BY NEGLIGENT USE, MISUSE, ALTERATION, OR ACCIDENT. ANY NEGLIGENT USE, MISUSE, ALTERATION, OR DAMAGE DUE TO ACCIDENT, AS DETERMINED BY A COMPANY REPRESENTATIVE, MAY VOID THE WARRANTY. THIS WARRANTY COVERS ONLY PRODUCTS MANUFACTURED BY THE COMPANY. THIS WARRANTY IS EXCLUSIVE AND IN LIEU OF ALL OTHER WARRANTIES EXPRESS OR IMPLIED. WE RESERVES THE RIGHT TO MAKE DESIGN OR SPECIFICATION CHANGES AT ANY TIME, BEARING NO RESPONSIBILITY TO MAKE SIMILAR DESIGN OR SPECIFICATION CHANGES ON PREVIOUSLY SOLD MERCHANDISE.

PRIOR TO INSTALLATION, PURCHASER HAS THE RESPONSIBILITY TO RESEARCH AND COMPLY WITH ALL FEDERAL, STATE, AND LOCAL CODES WHICH MAY APPLY TO THE LOCATION AND INSTALLATION.

---

This Equipment shall be installed in accordance with the current installation codes and applicable regulations which should be carefully followed in all cases. Authorities having jurisdiction should be consulted before installation occurs.



**1004 East Illinois Street  
Assumption, IL 62510  
217-226-4421 Phone**