

Series II 26" and 32" Tall En-Masse Chain Conveyors

Installation and Operation Manual

PNEG-1043

Date: 05-14-14

G S I G R O U P



PNEG-1043

Equipment Information

Use of the Equipment Information page will help you identify your equipment in case you need to call your dealer or installer. This information should be filled out and kept on record.

Equipment Information

Model Number: _____

Date Purchased: _____

Serial Number: _____

Dealer/Distributor Name and Phone Number:

GSI Material Handling

1004 E. Illinois St.

Assumption, IL. 62510-0020

Phone: 1-217-226-4421

Fax: 1-217-226-4420

www.gsiag.com

Contents

- Chapter 1 Safety4**
 - Safety Guidelines 4
 - Safety Sign-Off Sheet 5
- Chapter 2 Safety Decals6**
 - Head Section Decal Locations 6
 - Tail Section Decal Locations 7
- Chapter 3 General Precautions8**
- Chapter 4 Inspection9**
 - Receiving Inspection 9
 - Pre-Installation Preparation 9
- Chapter 5 Installation10**
 - Head and Tail Assembly 10
 - Intermediate Trough Section Assembly 10
 - Cover Assembly Installation 12
 - Inlet Assembly and Installation 12
 - Drag Chain Assembly Installation 13
 - Installing Shaft Mount Reducers 14
 - Torque Arm Bracket Installation 15
- Chapter 6 Care and Maintenance16**
 - Storage 16
 - Welding 16
 - Motor 16
 - Support 17
 - Clearance 17
 - Discharge 17
- Chapter 7 Options18**
 - Inspection Ports 18
 - Plug Relief Door 18
 - Slack Chain Assembly 19
- Chapter 8 Optional Carry-Over Bars21**
 - Carry-Over Bars - Reversing Conveyor 21
- Chapter 9 Troubleshooting22**
- Chapter 10 Warranty23**

Safety Guidelines

This manual contains information that is important for you, the owner/operator, to know and understand. This information relates to protecting **personal safety** and **preventing equipment problems**. It is the responsibility of the owner/operator to inform anyone operating or working in the area of this equipment of these safety guidelines. To help you recognize this information, we use the symbols that are defined below. Please read the manual and pay attention to these sections. Failure to read this manual and its safety instructions is a misuse of the equipment and may lead to serious injury or death.



This is the safety alert symbol. It is used to alert you to potential personal injury hazards. Obey all safety messages that follow this symbol to avoid possible injury or death.



DANGER indicates a hazardous situation which, if not avoided, will result in death or serious injury.



WARNING indicates a hazardous situation which, if not avoided, could result in death or serious injury.



CAUTION, used with the safety alert symbol, indicates a hazardous situation which, if not avoided, could result in minor or moderate injury.



NOTICE is used to address practices not related to personal injury.

Head Section Decal Locations

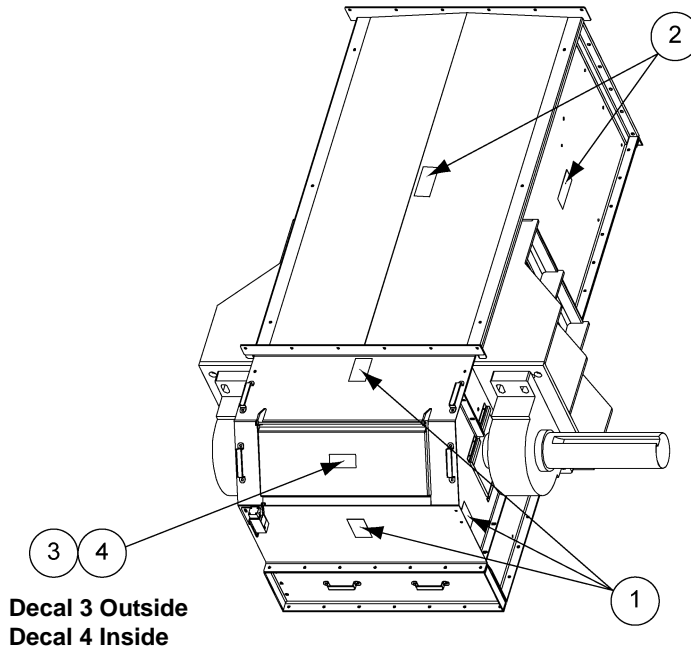

WARNING

Moving parts can crush and cut. Keep hands clear. Do not operate without guards in place. Failure to do so could result in serious injury.

GSI Group 217-226-4421 DC-972

1

WARNING

EXPOSED CONVEYORS
Moving parts can cause serious injury. Lockout power before removing covers or inspection door.

GSI Group Inc. 217-226-4421 DC-1230

2

WARNING

Moving parts can crush and cut.

- Keep hands clear.
- Do not operate with guard removed.
- Disconnect and lockout power before servicing.

The GSI Group 217-226-4421 DC-996

3

DANGER

Moving parts can crush and cut.

- Keep hands clear
- Do not operate with guard removed.
- Disconnect and lockout power before servicing.

The GSI Group 217-226-4421 DC-997

4

Tail Section Decal Locations

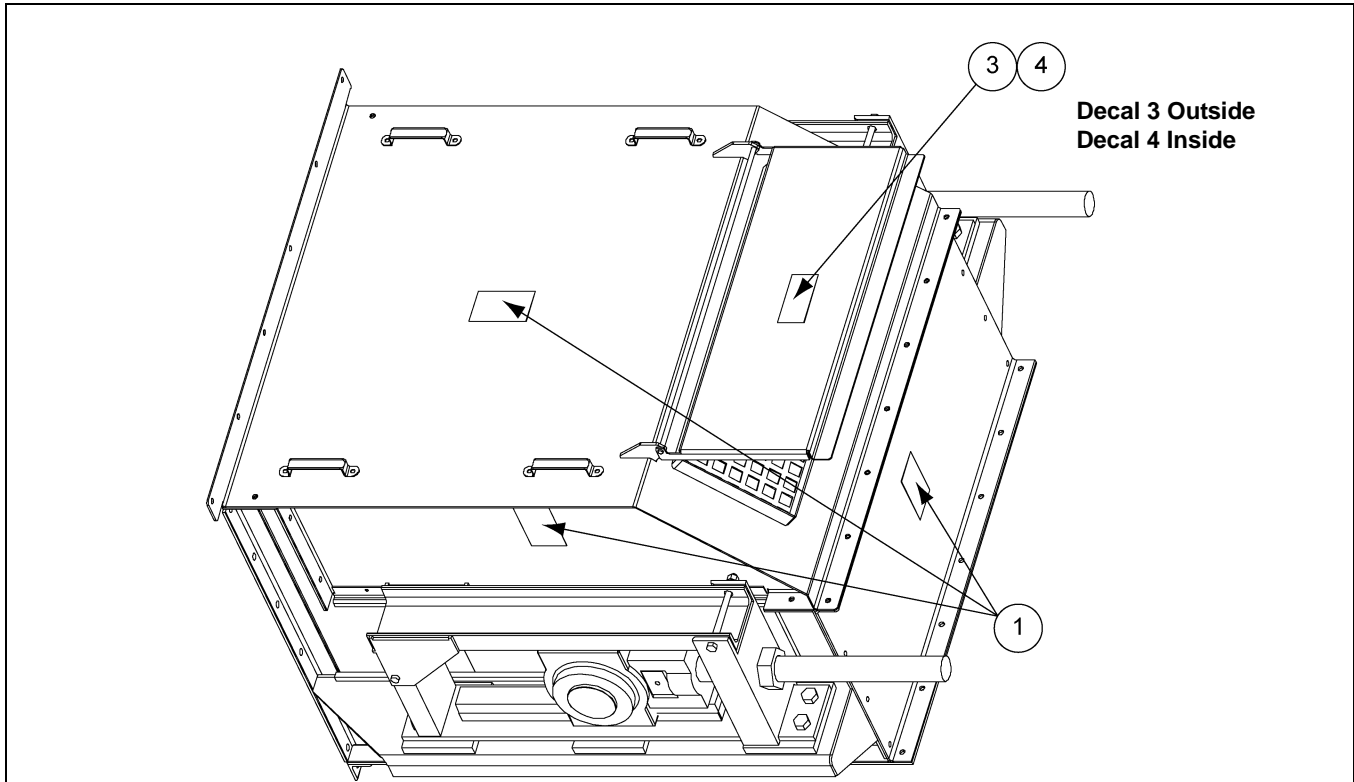

! WARNING

Moving parts can crush and cut. Keep hands clear. Do not operate without guards in place. Failure to do so could result in serious injury.

GSI Group 217-226-4421 DC-972

1

! WARNING

Moving parts can crush and cut.

- Keep hands clear.
- Do not operate with guard removed.
- Disconnect and lockout power before servicing.

The GSI Group 217-226-4421 DC-996

3

! DANGER

Moving parts can crush and cut.

- Keep hands clear.
- Do not operate with guard removed.
- Disconnect and lockout power before servicing.

The GSI Group 217-226-4421 DC-997

4

3. General Precautions



1. *Read and understand the Operator's manual BEFORE operating the unit.*
2. *Keep all safety shields and devices in place.*
3. *Keep all covers in place.*
4. *Make certain everyone is clear of the equipment before operating.*
5. *Keep hands, feet and clothing away from moving parts.*
6. *Shut OFF and lock out all power to adjust, service, clean or unclog the unit.*
7. *Keep off the equipment at all times.*
8. *Keep children, visitors and all untrained personnel away from the machine when in operation.*
9. *Do not operate electric motor equipped units until motors are properly grounded.*
10. *Disconnect power on electrical driven units before resetting motor overloads.*
11. *Do not repetitively stop and start the drive in order to free a plugged condition. "Jogging" the drive in this manner can damage the conveyor and/or drive components.*

Receiving Inspection

Carefully inspect the shipment as soon as it is received. Verify that the quantity of parts or packages actually received corresponds to the quantity shown on the packing slip. Any discrepancies should be clarified immediately. Please remember that any damage or missing parts must be noted on the bill of lading at the time of delivery. Report any damage or shortage to the delivering carrier as soon as possible. GSI's responsibility for damage to the equipment ends with acceptance by the delivering carrier.

Save all paperwork and documentation furnished with any of the en-masse conveyor components.

Pre-Installation Preparation

Familiarize yourself thoroughly with this manual and all the conveyor parts. Read the Operator's manual and all safety signs before using or servicing equipment. Taking the time to do so will aid in the assembly of the conveyor.

Remove all banding and crating material. Arrange the conveyor components so that they are easily accessible.

Locate sturdy items to serve as blocking. (i.e. wood blocks, saw horses, etc.) Blocking is used to support the conveyor sections above the ground to help in assembly. Locate and place the conveyor sections on the blocking in order, starting with the head section and concluding with the tail section.

5. Installation

Head and Tail Assembly

The head and tail sections of the chain conveyor are shipped pre-assembled direct from the factory. Intermediate trough sections may come factory pre-assembled or unassembled. The order will serve as a reference to how the trough section will arrive. If you have any questions, please refer to the order confirmation.

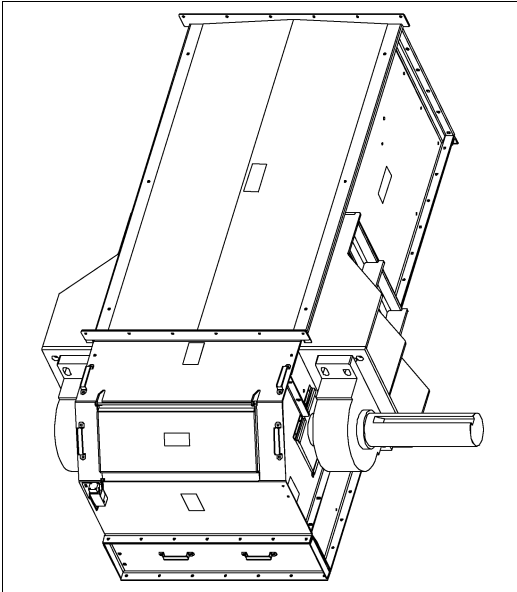

Figure 5A Head Assembly

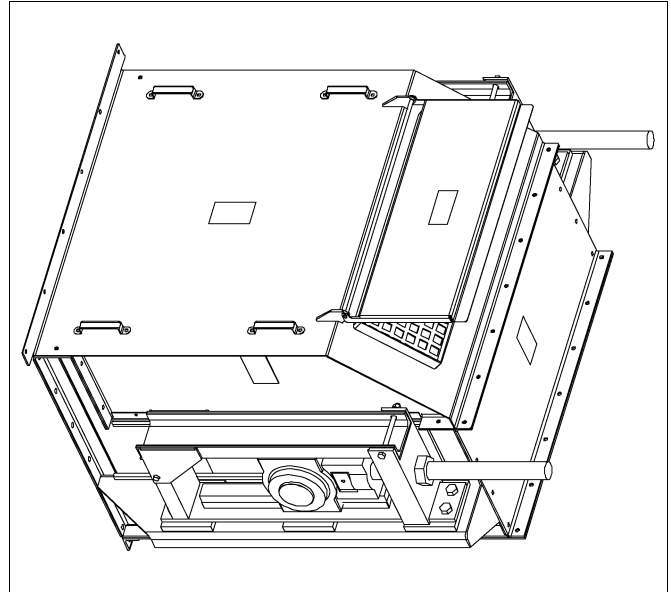

Figure 5B Tail Assembly

Intermediate Trough Section Assembly

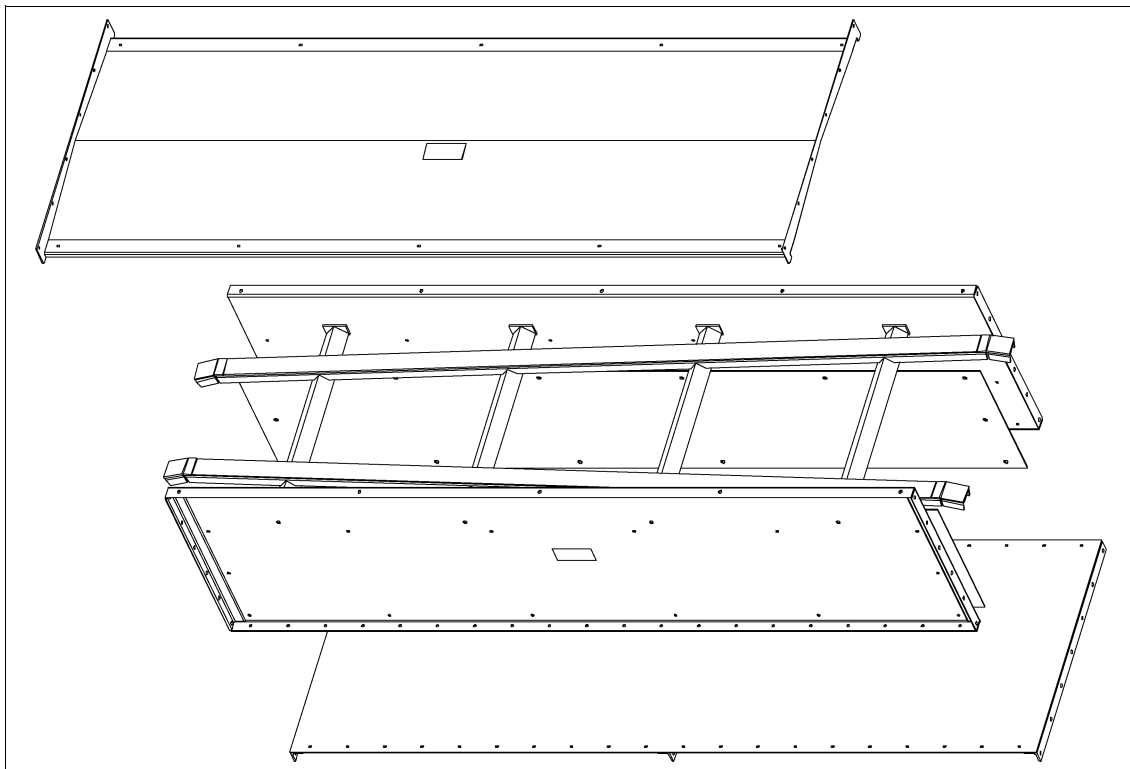

Figure 5C Typical Intermediate Trough Section Assembly

An en-masse conveyor may be purchased with unassembled trough sections. The following recommendations may prove useful in the assembly.

Before assembling conveyor trough sections together, remove the covers. Covers should be stored in a protected area in order to minimize any possible damage. Remember to retain factory shipped hardware for conveyor cover installation.

Take a moment to familiarize yourself with the trough assembly. Install the slide rail returns so that the wide ends of the rail returns face *away from* the discharge end of the conveyor. The narrow end of the rail returns, therefore, will face *toward* the discharge end.

Intermediate trough sections are supplied in standard ten feet (10') lengths. Depending on the application and individual specifications however, shorter sections may be required to accommodate a desired overall length.

Lay bottom plate weldment on blocking material. Next, loosely attach side weldments to bottom plate with 3/8" hardware provided. Then fasten slide rail return weldment to intermediate sides with the 1/2" hardware.

NOTE: *It is critical for straightness of the conveyor that the sides and bottom flanges are aligned flush. Also, it is important that the inside dimensions of the box are equidistant in measurement from side-to-side both top and bottom of the trough box (Dimension A = Dimension B). (See Figure 5D.)*

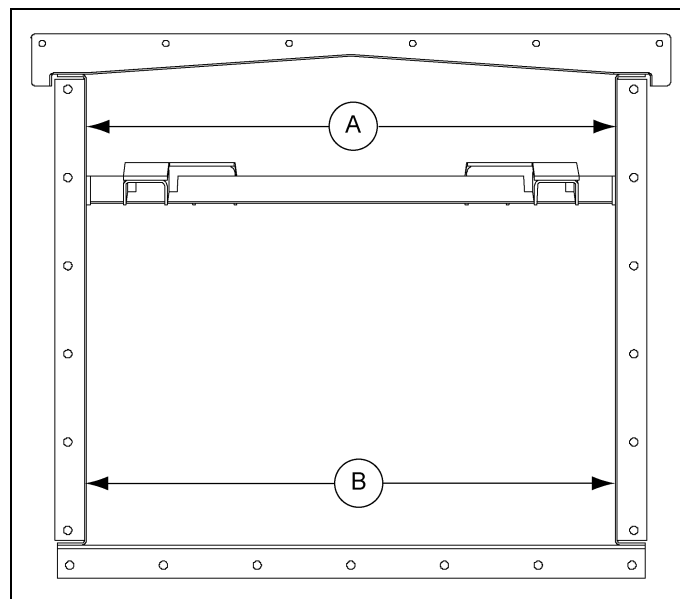

Figure 5D End View of Trough Section (Liners not shown for clarity.)

After making sure the flanges are aligned, tighten all hardware on the trough section. Abrasion Resisting (A.R.) liners are installed with the 3/8" flat countersunk hardware provided. Adequately tighten liners to conveyor sides. Make sure that the countersunk hardware is not protruding above the surface of the A.R. liners.

During assembly of each trough section to the next section, carefully inspect each flange joint to ensure that the inside bottom and side surfaces of the troughs are flush. A chalk line is helpful during this phase of the assembly to ensure the proper alignment of the trough surfaces. The maximum run-out in any direction should be $\pm 1/4"$. Proper alignment minimizes wear on flights and other potential damage to the conveyor. Make sure the conveyor is level in horizontal applications.

Proceed by attaching the head and tail assemblies using the same alignment procedures and precautions noted in the preceding paragraph.

5. Installation

Cover Assembly Installation

Fasten covers to the en-masse conveyor with the 3/8" and 1/2" hardware provided. Adequately tighten the 1/2" bolts and nuts so that the vertical cover seams are in tight contact with each other.

When an inlet is on the conveyor, a cover section may have to be cut accordingly to accommodate the inlet. For installation of an inlet, see inlet assembly and installation below.

Inlet Assembly and Installation

One inlet is typically provided per conveyor. GSI's recommendation for inlet installation includes a minimum distance of no less than 6" between the closest edge of the inlet and the tail assembly.

(See Figure 5E.)

The inlet can be attached with continuous weld seams. If intermittently welded, it is important to use caulking or sealing around the inlet area in order to seal the unit.

Similarly, GSI recommends that if inlets are welded onto the conveyor, this procedure should be done before the installation of motor and/or other electrical devices. If the owner fails to follow this precaution, the owner assumes all risks associated with this installation.

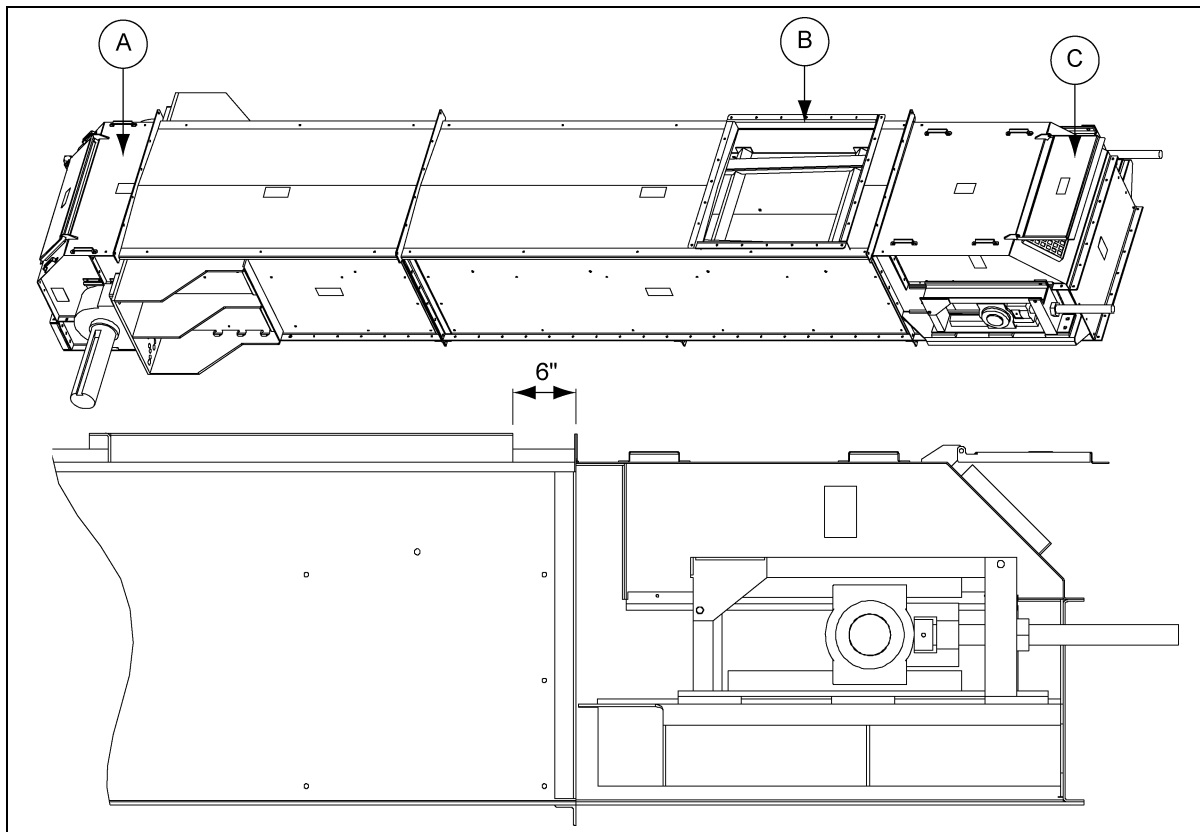

Figure 5E

| Ref # | Description |
|-------|--------------------|
| A | Head Discharge End |
| B | Standard Inlet |
| C | Tail End |

Drag Chain Assembly Installation

All chain supplied with new conveyors, regardless of type, will be installed in a similar manner. Correct total chain length has been determined for the installation by GSI. The conveyor drag chain is shipped in approximate ten feet (10') lengths with an additional pre-cut short section, if necessary (refer to packing list). If welded chain (WH132, WH155 or WH157) has been supplied with the conveyor, a minimum of five feet (5') of chain with cottered pin connectors will be supplied. These pin connectors and links may be removed as necessary for chain take-up. The chain may be installed at any time during conveyor assembly.

It is recommended however, that you position the chain over the slide rail returns and the sprockets in the head and tail assemblies. The UHMW wear pads should be in front of the welded chain flights in the direction of chain travel (A). (See Figure 5F.) Connect chain lengths together with connecting links and/or pins.

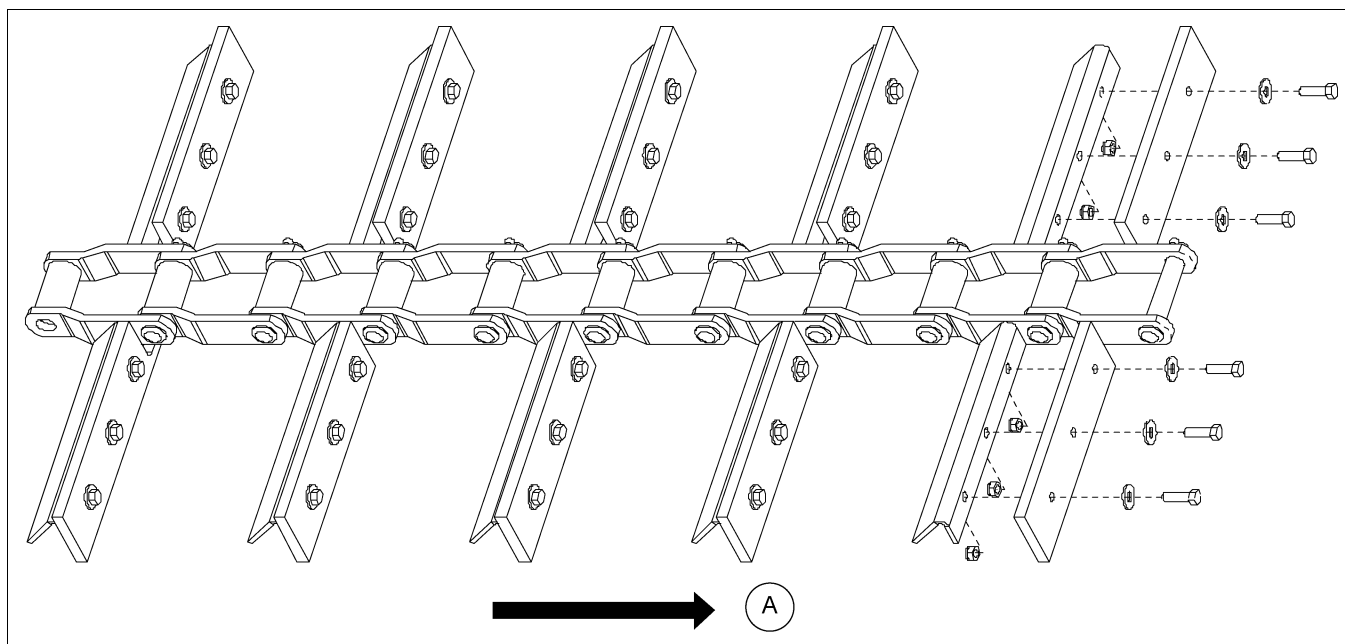

Figure 5F

| Ref # | Description |
|-------|--------------------------------------|
| A | Direction of Chain Travel Bottom Run |

Tighten the drag chain assembly using the take-up screws located on each side of the tail section or on the take-up head. The chain should be able to be lifted slightly when sufficiently tightened. After the chain is tight, check that the head and tail shafts are square to the box sides. If the shafts are not square, loosen the tighter of the two take-up screws until the shafts are square. Lock the take-up screws by tightening the jam nuts.

Rotate the chain, now on the sprockets, at least one complete revolution. Check to see that the chain and its wear pads are not catching on flanges or rubbing on the trough liners. Ensure a break-in period whereby the chain is allowed to run and seat itself. After running it for an adequate period of time, stop the machine, disconnect and lock out the power source. Re-tighten as necessary and remove any excess chain portions. Repeat this process as necessary.

5. Installation

Installing Shaft Mount Reducers

Assemble torque arm bracket to conveyor per installation instructions found on [Page 15](#).

To aid in the installation of the reducer onto the shaft, remove any protective coating film from shaft. Slide the reducer onto the drive shaft extending from the side of the conveyor head section. Using the instructions and hardware supplied with the reducer, assemble it to the conveyor drive shaft.

Assemble motor mount to the reducer. Refer to installation instructions provided with motor mount.

Install the rear panel of the drive guard before mounting the sheaves. The rear panel has four (4) mounting brackets with slotted holes. Attach the lower brackets to the matching reducer assembly bolts. Attach the upper brackets to the matching holes in the front motor mount support.

Assemble the V-belt driven sheave to the input shaft of the shaft mount reducer. Slide the sheave hub onto the shaft and insert the square key. Attach the hub sheave using the supplied retaining screws. The retaining screws pass through the non-threaded holes of the hub and into the sheave. Align the driver and driven sheaves and tighten the retaining screws. During tightening, it is possible for the sheave to move out of alignment or become out of square. For maximum V-belt life, the driven sheave should remain both perpendicular to the drive shaft and aligned with the drive sheave. Slip the V-belts over both the driver and driven sheaves.

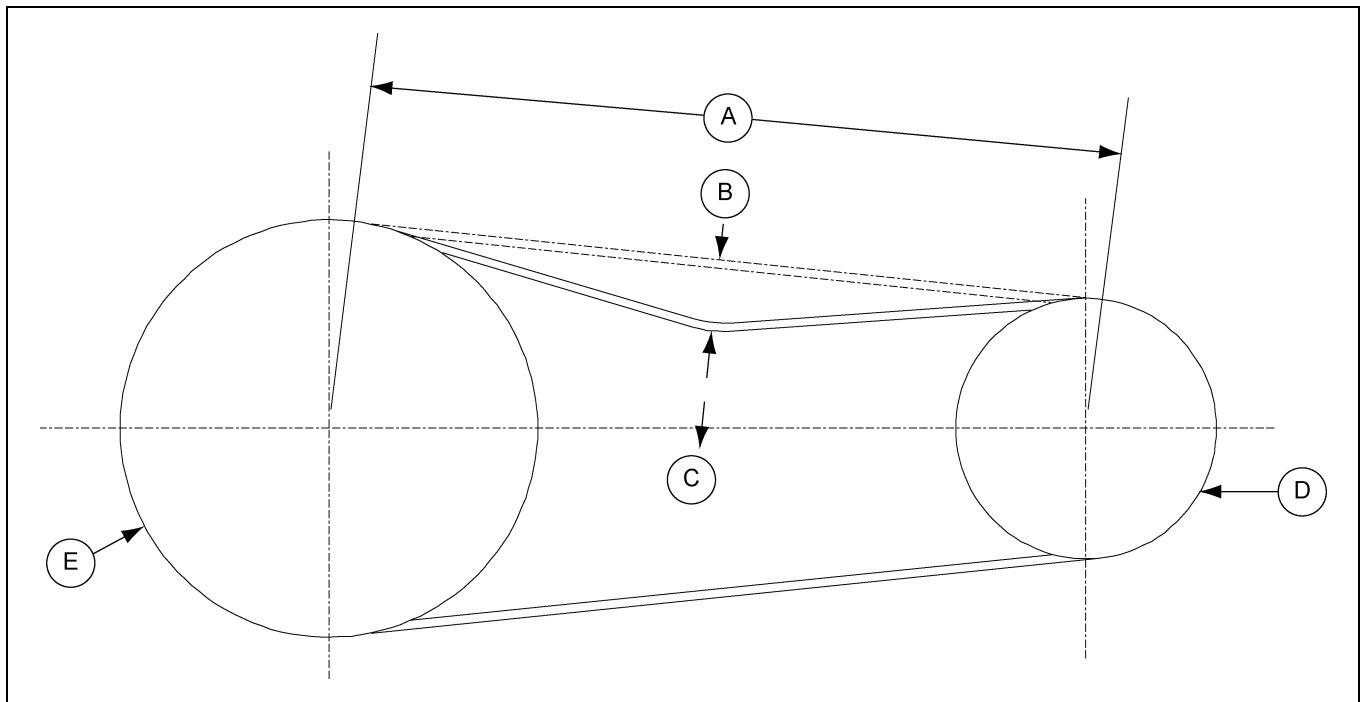

Figure 5G

| Ref # | Description |
|-------|--|
| A | Span |
| B | Belt deflection 1/64" per inch of span |
| C | Force |
| D | Motor |
| E | Reducer |

Adjustment of V-belt tension is achieved by tightening the hex nuts located on the four (4) jackscrews of the motor base. Adjust motor base equally at all four (4) jackscrews to maintain shaft alignment. Belts are designed to fit loose upon installation. When the V-belt tension is correct, tighten the top nut on the jackscrews to lock the motor base in position. Proper tension is 1/64" of deflection per one inch (1") of sheave centers on one side of belt, centered between sheaves.

NOTE: *Too much tension shortens belt life. Check belt tension frequently during the first 24-48 hours of operation.*

Install the front drive guard panel over the four (4) corner mounting studs. Secure with washers and nuts provided.

Fill the shaft mount reducer with the manufacturer's recommended oil. A list of recommended oil can be found in the gear reducer instructions.

Torque Arm Bracket Installation

When a drive package is ordered with the conveyor system, a torque arm bracket is provided.

The torque arm bracket is pre-punched for ease of installation on the unit. Begin installation of this option by first determining the location of the torque arm bracket relative to the range of extension allowed by the shaft mount reducer's torque arm. The bracket will extend on the same side of the conveyor as the head shaft. Remove the 5/8" bolts necessary from the bottom of the conveyor head bottom plate.

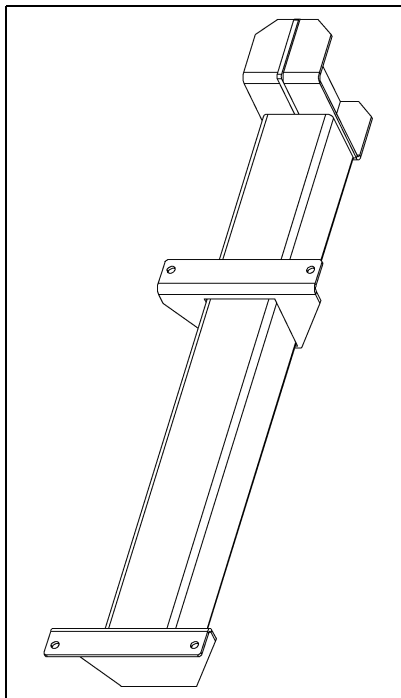

Figure 5H *Torque Arm Bracket*

Set the torque arm bracket in place and attach with the 5/8" hardware previously removed from the bottom plate of the conveyor. Four (4) 5/8" bolts and nuts are required to fasten the torque arm bracket to the conveyor.

Install shaft mount reducer to head shaft per instructions on [Page 14](#).

Next, match the size of the hardware to the reducer manufacturer's torque arm. Use this hardware to attach the torque arm to the bracket. Adequately tighten all hardware.

6. Care and Maintenance



Before any maintenance is performed to the conveyor, shut OFF and lock out power to prevent accidental start-up.

The care and maintenance section is provided to help extend the useful life of the unit. Like all equipment, the useful life of the conveyor is greatly reduced if not used wisely and well maintained.

Please follow the next few simple steps to ensure the safety and longevity of the equipment.

1. Check all bearings and moving parts daily during use.
2. Lubricate bearings according to bearing manufacturer's recommendations.
3. Follow manufacturer's recommendations for gear reducer lubrication and maintenance.
4. Inspect the V-belts periodically for proper tension and wear. V-belts should be replaced as necessary. If replacement or tension adjustment is required, please refer to the shaft mount reducer assembly section [on Page 14](#).
5. The drag chain and sprockets should be checked periodically for wear, damage and proper adjustment. Any broken or bent paddles should be replaced or straightened. Should adjustment or replacement of the drag chain be required, refer to assembly section [on Page 13](#).

Storage

If the unit is to be inactive for an extended period, the following procedures are recommended.

1. Thoroughly clean the unit.
2. Loosen the drag chain tension. Doing so relieves the stress placed on the bearings and shafts of the drive and tail sections.
3. Lubricate drag chains, shafts and drive components with a good grade of light machine oil.

Welding

Welding on or to the conveyor may cause damage to both the conveyor and its electrical system. If welding is necessary, measures should be taken to protect the conveyor. Should it be necessary to fasten anything to the conveyor permanently, careful consideration should be given to methods of maintenance, removal and replacement of the conveyor and/or its parts. (Please refer to Inlet Installation for GSI recommended guidelines.)

Motor

Connect the conveyor motor to a power source according to the motor manufacturer's instructions and recommendations. To avoid injury it is recommended that a certified electrician perform the motor wiring. A shut off switch should be placed near the motor so that the system may easily be shut down to help prevent accidents during maintenance. It is important to check proper motor shaft rotation before installing drive belts.

Support

GSI's recommended general guidelines in this area include adequate support for the conveyor assembly to be installed at intervals no greater than 10 feet (10'). It is recommended that supports be installed at vertical portions of flanges, leaving bottoms of trough sections clear. By attaching supports in this manner, the removable bottoms are unobstructed for easy replacement. Support legs are available as an option.

Clearance

A clearance of at least the width of the conveyor is recommended on all sides of the unit. While clearance may be acceptable, serious consideration must be given to methods of maintenance, removal and replacement of the conveyor and/or its parts.

Discharge

The standard conveyor is constructed with one discharge located at the drive end. If intermediate discharges are to be used, the location(s) must be determined prior to proceeding with the conveyor assembly. Intermediate discharges cannot be installed over a trough joint; therefore, it may be necessary to position a shorter trough section to serve as a spacer in order to accommodate the placement of the discharge(s) where they are required.

The owner assumes all responsibility for any alterations to the equipment.

7. Options

Inspection Ports

After determining location(s) for the inspection port(s) on conveyor, cut an 11-3/4" square hole in the cover for each inspection port. Cut the square opening so that it is centered over the peak of the conveyor cover.

Position the inspection port over the square hole until its frame is flush to the cover. Weld inspection port to conveyor cover. Additional caulking may be required so that water will shed from the inspection port.

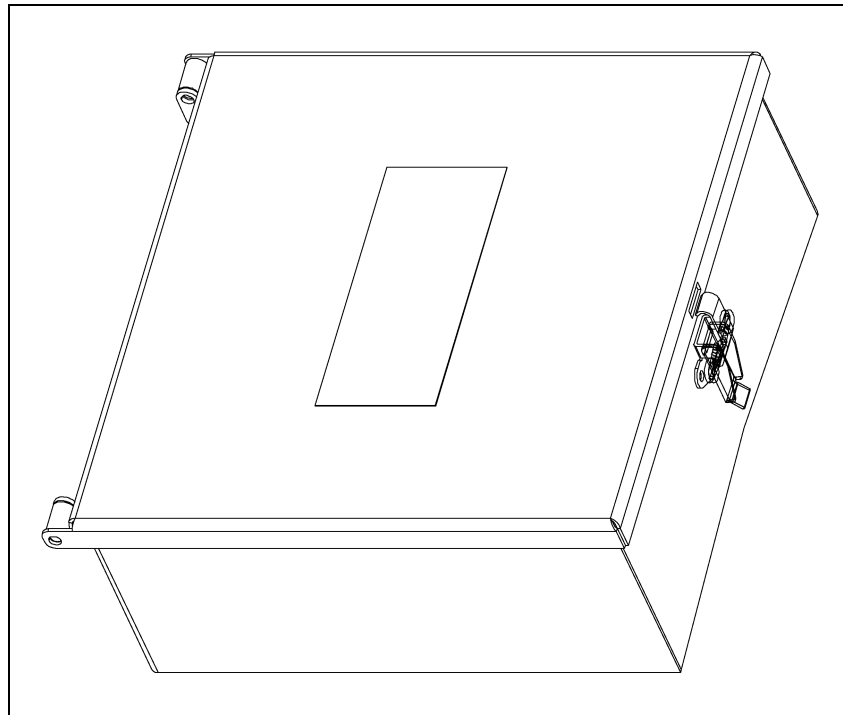

Figure 7A

Plug Relief Door

GSI Series 2 26" and 32" tall en-masse conveyors come equipped with a head discharge plug relief door as a standard feature. A NEMA 4 heavy duty limit switch is standard on the relief door.

However, in extremely dirty, dusty conditions and/or in enclosed environments, a NEMA 9 heavy duty limit switch should be used on the plug relief door. The NEMA 9 limit switch is available as an added option.

The optional NEMA 9 limit switch (GSI part # CE-00504) attaches to the same universal bracket on the front of the head assembly as the standard NEMA 4 limit switch. The same hardware is used for both limit switches.

NOTE: *The limit switch bracket must be oriented as shown for proper engagement between limit switch and plug relief door.*

Attach the bracket to the hood cover with two (2) 5/16" bolts and nuts where two (2) pre-punched holes are located. Two (2) pairs of pre-punched holes are provided on the removable head hood cover—one (1) pair on the left side and one (1) pair on the right side of hood cover. Next, use two (2) #10 machine screws, nuts and washers to fasten the limit switch to the bracket. The limit switch can be installed either to the left or to the right. Do not tighten these machine screws at this time.

Adjust the limit switch so that the actuator arm keeps sufficient tension against the plug relief door. After the limit switch is properly positioned, tighten the two (2) machine screws.

Plug Relief Door (Continued)

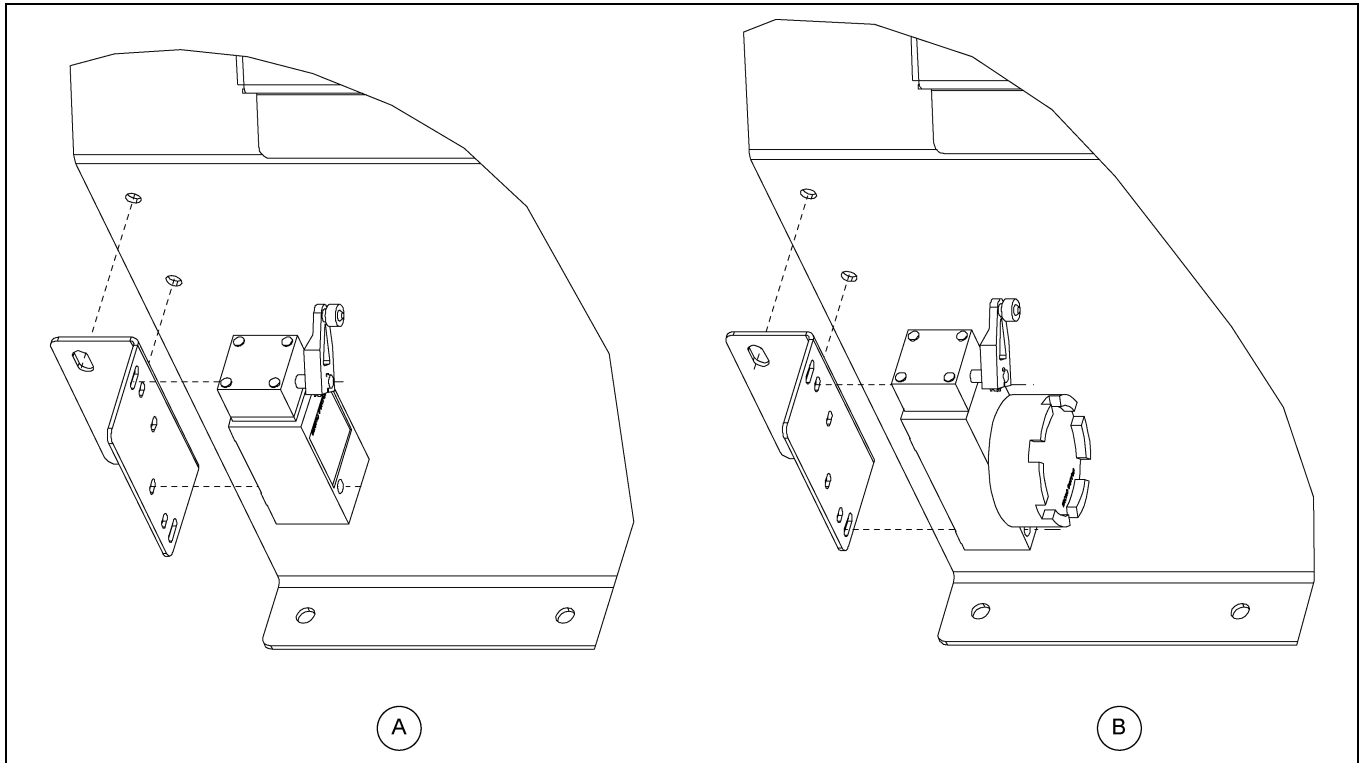

Figure 7B

| Ref # | Description |
|-------|---|
| A | Standard Plug Relief Door Limit Switch |
| B | Optional NEMA 9 Limit Switch GSI (CE-00504) |

Slack Chain Assembly

The GSI Group offers a slack chain detector system as an option for its 26" and 32" tall series II en-masse conveyors. Depending on working conditions and/or environment, either a NEMA 4 or a NEMA 9 limit switch is available.

Begin installation of optional slack arm assembly by first cutting a 12" x 5" rectangular hole in the head section cover. ([See Figure 7C on Page 20.](#))

Next, center the slack chain assembly over the rectangular opening. Mark the locations for the four (4) 7/16" diameter holes. Temporarily remove the slack chain assembly, and drill the four (4) 7/16" diameter holes.

Before attaching slack chain assembly to the conveyor, apply sealant to bottom surfaces of slack chain assembly.

Fasten slack chain assembly to conveyor with 3/8" hardware. [See Figure 7C on Page 20](#) regarding direction of slack chain assembly on the conveyor.

After installation, check that the clearance between the UHMW paddle in the slack chain assembly and the UHMW flights on the chain is approximately 1/2" to 3/4". Adjust if necessary.

Slack Chain Assembly (Continued)

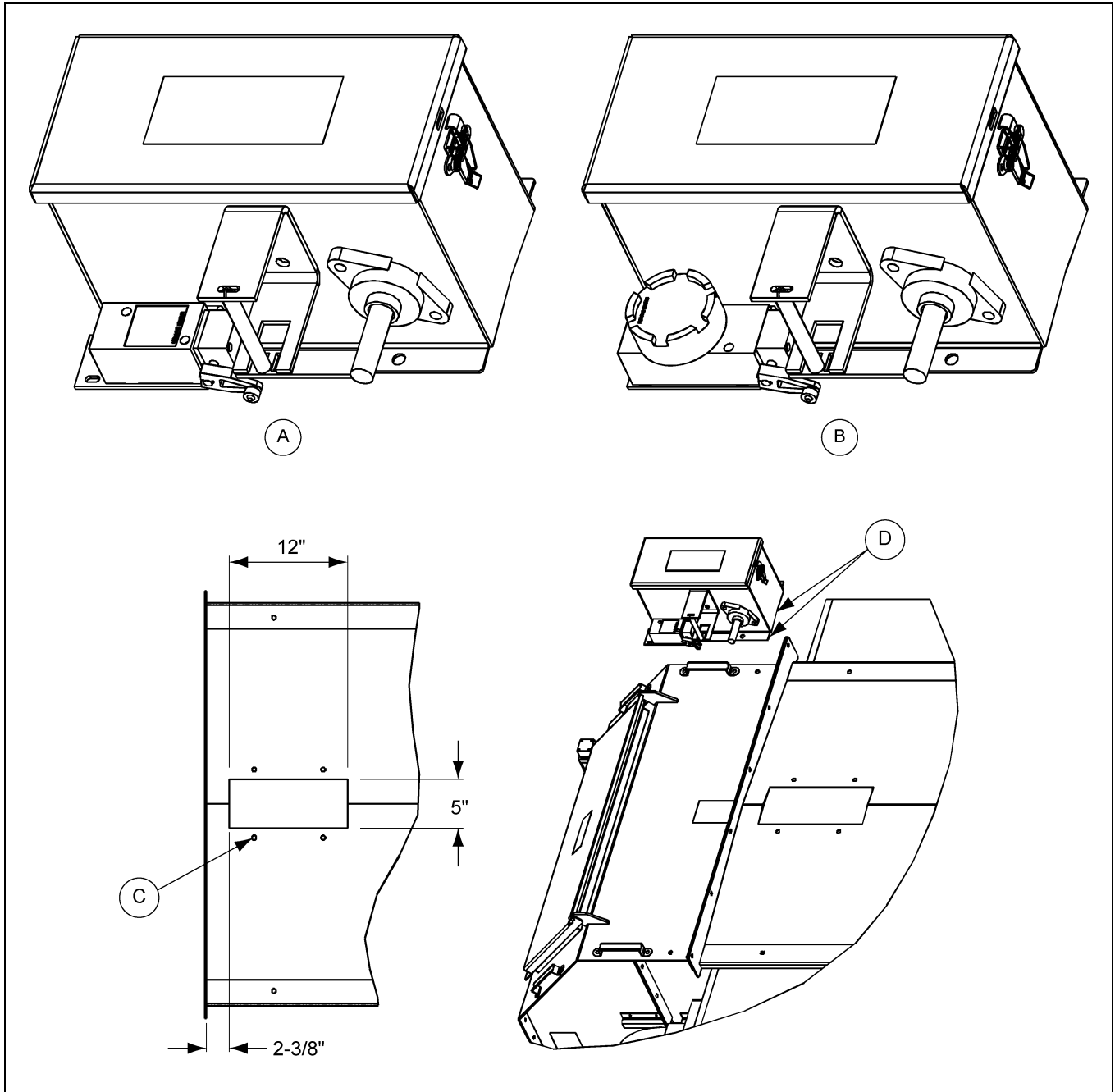

Figure 7C

| Ref # | Description |
|-------|---|
| A | Top Mount Slack Chain with NEMA 4 Limit Switch |
| B | Top Mount Slack Chain with NEMA 9 Limit Switch |
| C | Ø 7/16" Typical |
| D | Apply sealant to underside all around before attaching to conveyor. |

Carry-Over Bars - Reversing Conveyor

For applications where the en-masse conveyor may run in a reverse direction, carry-over bars should be installed in the head assembly. These bars will ensure a smooth transition of the chain and flights from the head discharge into the conveyor box.

The carry-over bar package consists of four (4) carry-over bars, four (4) clips, and two (2) shims, plus the hardware necessary to attach these components within the head assembly.

Pre-assemble the two (2) pairs of carry-over bars and clips using the 3/8" bolts and nuts. Be sure to center the clips to the vertical slots on each end of the carry-over bars.

Next, place the pre-assembled pairs of carry-over bars in the head discharge as shown in *Figure 8A*. *It is imperative that these carry-over bars be spaced so that they pick up the UHMW flights as shown in Figure 8A.*

After the two (2) pairs of carry-over bars have been positioned, mark the locations for the eight (8) 9/16" diameter holes and drill. Attach with the 1/2" hardware provided.

After installation, check that the top edge of the carry-over bars does not extend above the top surface of the bottom plate.

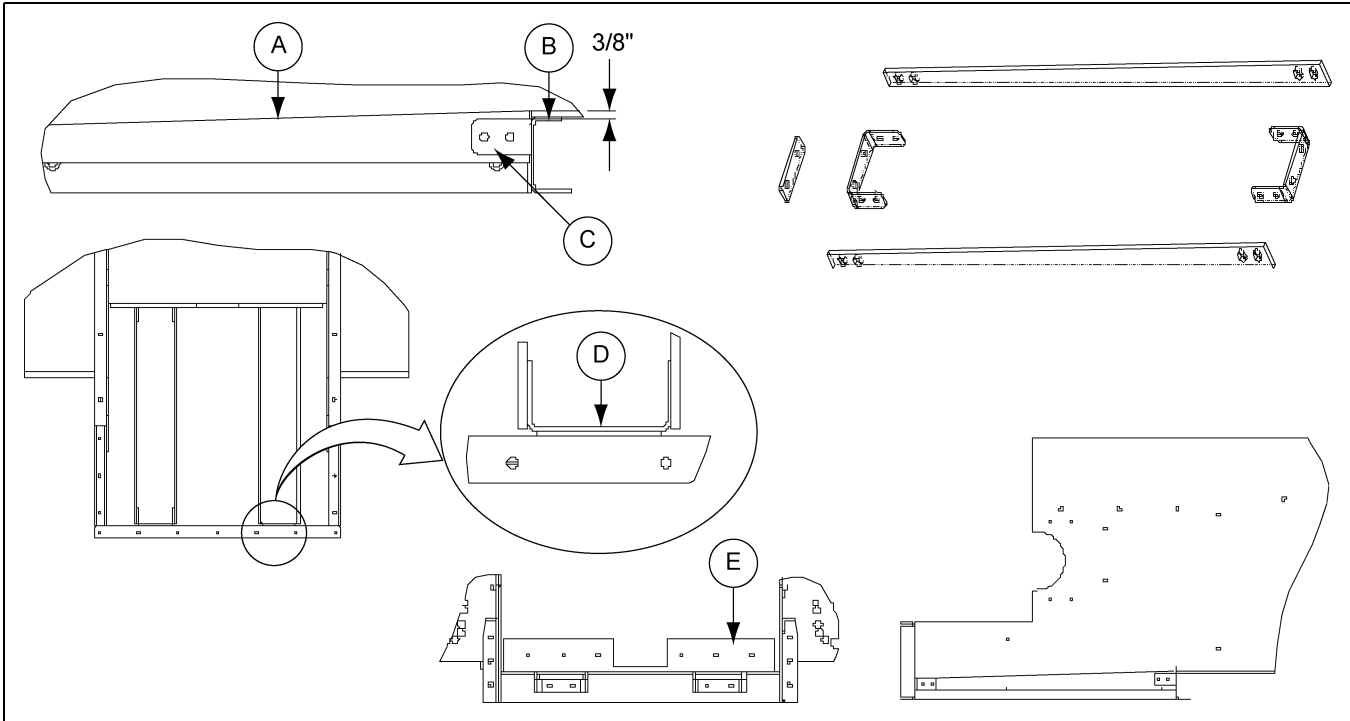

Figure 8A

| Ref # | Description |
|-------|---|
| A | Carry-Over Bar |
| B | Top Surface of Bottom Plate |
| C | Clip |
| D | Place shim between this clip and end panel. |
| E | UHMW Flight |

9. Troubleshooting

Troubleshooting Guide

| Problem | Cause | Solution |
|--------------------------------|---|---|
| Low capacity | <ol style="list-style-type: none"> 1. Improper chain speed. 2. Improper feed. 3. Plugging. | <ol style="list-style-type: none"> 1. Check the shaft RPM. 2. Check the grain level at inlet. 3. Check the discharges. |
| Noisy operation | <ol style="list-style-type: none"> 1. Loose UHMW paddles. 2. Bottom are sides not aligned. 3. Worn Drive Components. 4. Worn sprocket. 5. Return rail alignment. | <ol style="list-style-type: none"> 1. Check all bolts on chain. 2. Check intermediate trough section joints and make flush. 3. Check oil level and shaft seals; belt misalignment; loose belts. 4. Replace. 5. Check rail alignment. |
| Uneven UHMW paddle wear | <ol style="list-style-type: none"> 1. Conveyor misalignment. 2. Sprocket slipped. 3. Return rail alignment. | <ol style="list-style-type: none"> 1. Check the conveyor alignment. 2. Check set screws on sprockets. 3. Check rail alignment. |
| Excessive carry-over | <ol style="list-style-type: none"> 1. Gates not fully opening. | <ol style="list-style-type: none"> 1. Check the gate operation. |
| Uneven sprocket wear | <ol style="list-style-type: none"> 1. Worn chain. 2. Improper alignment. 3. Material carry-over into discharge sprocket. | <ol style="list-style-type: none"> 1. Replace chain. <i>(See Page 13.)</i> 2. Check the sprocket alignment. 3. Check for improper location of inlet. <i>(See Page 12.)</i> |

Consult the contractor for added assistance.

GSI Group, LLC Limited Warranty

The GSI Group, LLC ("GSI") warrants products which it manufactures to be free of defects in materials and workmanship under normal usage and conditions for a period of 12 months after sale to the original end-user or if a foreign sale, 14 months from arrival at port of discharge, whichever is earlier. The end-user's sole remedy (and GSI's only obligation) is to repair or replace, at GSI's option and expense, products that in GSI's judgment, contain a material defect in materials or workmanship. Expenses incurred by or on behalf of the end-user without prior written authorization from the GSI Warranty Group shall be the sole responsibility of the end-user.

Warranty Extensions:

The Limited Warranty period is extended for the following products:

| | Product | Warranty Period | |
|--|---|-----------------|---|
| AP Fans and Flooring | Performer Series Direct Drive Fan Motor | 3 Years | * Warranty prorated from list price: 0 to 3 years - no cost to end-user 3 to 5 years - end-user pays 25% 5 to 7 years - end-user pays 50% 7 to 10 years - end-user pays 75% |
| | All Fiberglass Housings | Lifetime | |
| | All Fiberglass Propellers | Lifetime | |
| AP and Cumberland | Flex-Flo/Pan Feeding System Motors | 2 Years | |
| Cumberland Feeding/Watering Systems | Feeder System Pan Assemblies | 5 Years ** | ** Warranty prorated from list price: 0 to 3 years - no cost to end-user 3 to 5 years - end-user pays 50% |
| | Feed Tubes (1-3/4" and 2.00") | 10 Years * | |
| | Centerless Augers | 10 Years * | |
| | Watering Nipples | 10 Years * | |
| Grain Systems | Grain Bin Structural Design | 5 Years | |
| Grain Systems Farm Fans Zimmerman | Portable and Tower Dryers | 2 Years | † Motors, burner components and moving parts not included. Portable dryer screens included. Tower dryer screens not included. |
| | Portable and Tower Dryer Frames and Internal Infrastructure † | 5 Years | |

GSI further warrants that the portable and tower dryer frame and basket, excluding all auger and auger drive components, shall be free from defects in materials for a period of time beginning on the twelfth (12th) month from the date of purchase and continuing until the sixtieth (60th) month from the date of purchase (extended warranty period). During the extended warranty period, GSI will replace the frame or basket components that prove to be defective under normal conditions of use without charge, excluding the labor, transportation, and/or shipping costs incurred in the performance of this extended warranty.

Conditions and Limitations:

THERE ARE NO WARRANTIES THAT EXTEND BEYOND THE LIMITED WARRANTY DESCRIPTION SET FORTH ABOVE. SPECIFICALLY, GSI MAKES NO FURTHER WARRANTY OF ANY KIND, EXPRESS OR IMPLIED, INCLUDING, WITHOUT LIMITATION, WARRANTIES OF MERCHANTABILITY OR FITNESS FOR A PARTICULAR PURPOSE OR USE IN CONNECTION WITH: (I) PRODUCT MANUFACTURED OR SOLD BY GSI OR (II) ANY ADVICE, INSTRUCTION, RECOMMENDATION OR SUGGESTION PROVIDED BY AN AGENT, REPRESENTATIVE OR EMPLOYEE OF GSI REGARDING OR RELATED TO THE CONFIGURATION, INSTALLATION, LAYOUT, SUITABILITY FOR A PARTICULAR PURPOSE, OR DESIGN OF SUCH PRODUCTS.

GSI shall not be liable for any direct, indirect, incidental or consequential damages, including, without limitation, loss of anticipated profits or benefits. The sole and exclusive remedy is set forth in the Limited Warranty, which shall not exceed the amount paid for the product purchased. This warranty is not transferable and applies only to the original end-user. GSI shall have no obligation or responsibility for any representations or warranties made by or on behalf of any dealer, agent or distributor.

GSI assumes no responsibility for claims resulting from construction defects or unauthorized modifications to products which it manufactured. Modifications to products not specifically delineated in the manual accompanying the equipment at initial sale will void the Limited Warranty.

This Limited Warranty shall not extend to products or parts which have been damaged by negligent use, misuse, alteration, accident or which have been improperly/inadequately maintained. This Limited Warranty extends solely to products manufactured by GSI.

Prior to installation, the end-user has the responsibility to comply with federal, state and local codes which apply to the location and installation of products manufactured or sold by GSI.

This equipment shall be installed in accordance with the current installation codes and applicable regulations, which should be carefully followed in all cases. Authorities having jurisdiction should be consulted before installations are made.

G S I G R O U P



GSI Group
1004 E. Illinois St.
Assumption, IL 62510-0020
Phone: 1-217-226-4421
Fax: 1-217-226-4420
www.gsiag.com



GSI is a worldwide brand of AGCO Corporation.