

Chain Loop System without Controls

Owner's Manual

PNEG-1128

Date: 07-26-13

GSI GROUP



PNEG-1128

Contents

Chapter 1 Safety	5
Safety Guidelines	5
Safety Instructions	6
Grain Bin Safety	9
Chapter 2 Decals	10
Decal Placement	11
Chapter 3 Information	13
Chain Loop System Information	13
Final Inspection Check List	14
Chapter 4 Operation	15
Operating the Chain Loop System	15
Chapter 5 Management and Maintenance	17
Maintenance	17
Chain and Paddles	18
Chapter 6 Installation	19
Tube and Corner Assembly	21
Drive Assembly	22
Chain Loop Torque Arm Repair Kit	23
Drive Box Assembly Instructions	26
Discharge with Gate Assembly	27
Unload Well Installation	28
Chain and Paddles	29
Inspection Corner	31
Ground Control Kit for Discharge Gates	32
Inlet Dump Hopper Assembly	36
Chapter 7 Troubleshooting	38
Chapter 8 Component Dimensions	39
8", 10" and 12" Component Dimensions	39
8", 10" and 12" Bin Well and Dump Hopper Dimensions	41

Table of Contents

Chapter 9 Parts List	44
8" and 10" Chain and Paddles	46
12" Chain and Paddles (8120141)	47
8" and 10" Discharge Gate	48
12" - (7 Gauge) Discharge Gate (8120194)	49
12" - (10 Gauge) Discharge Gate (8120090)	50
Chain Loop Drive Components	52
8" (15 HP) Drive Components (8081365)	55
8" (20 HP) Drive Components (8081363)	56
8" (15 HP-20 HP) Drive Components (8081362)	57
10" (20 HP) Drive Components (8101526)	58
10" (15 HP-20 HP) Drive Components (8101525)	59
8" (25 HP-30 HP) Drive Components (8081360)	60
8" (25 HP-30 HP) Drive Components (8081359)	61
10" (25 HP-30 HP) Drive Components (8101517)	62
10" (25 HP-30 HP) Drive Components (8101516)	63
10" (40 HP) Drive Components (8101513)	64
10" (50 HP) Drive Components (8101514)	65
10" (40 HP-50 HP) Drive Components (8101511)	66
8" (15 HP) Drive Components (8081271)	67
8" (20 HP) Drive Components (8081285)	68
8"-10" (25 HP-30 HP) Drive Components (8081296)	69
10" (40 HP) Drive Components (8101303)	70
10" (50 HP) Drive Components (8101331)	71
Belt Guard Assembly TA3 (8120217)	72
Belt Guard Assembly TA4 (8120211)	74
Belt Guard Assembly TA5 (8120214)	75
12" 7 Gauge (30 HP) Drive Components (8120000)	76
12" 7 Gauge (40 HP-50 HP) Drive Components (8120144)	78
12" 7 Gauge (60 HP) Drive Components (8120163)	80
12" 10 Gauge (30 HP) Drive Components (8120175)	82
12" 10 Gauge (40 HP-50 HP) Drive Components (8120179)	84
12" 10 Gauge (60 HP) Drive Components (8120180)	86
8" and 10" Inlet Dump Hoppers	88
12" (7 Gauge) 42-1/2" Inlet Dump Hoppers (8120121)	89
12" (7 Gauge) 102-1/2" Inlet Dump Hoppers (8120127)	90
12" (7 Gauge) 122-1/2" Inlet Dump Hoppers (8120134)	91
12" (10 Gauge) 42-1/2" Inlet Dump Hoppers (8120185)	92
12" (10 Gauge) 102-1/2" Inlet Dump Hoppers (8120186)	94
12" (10 Gauge) 122-1/2" Inlet Dump Hoppers (8120187)	95
8" and 10" Standard Corner	96
12" (7 Gauge) Standard Corner (8120031)	98
12" (10 Gauge) Standard Corner (8120176)	100
8" and 10" Inspection Corner	102
12" (7 Gauge) Inspection Corner (8120051)	104
12" (10 Gauge) Inspection Corner (8120177)	106
Chain Loop Torque Plate Assembly	108
Chapter 10 Warranty	109

Safety Guidelines

This manual contains information that is important for you, the owner/operator, to know and understand. This information relates to protecting **personal safety** and **preventing equipment problems**. It is the responsibility of the owner/operator to inform anyone operating or working in the area of this equipment of these safety guidelines. To help you recognize this information, we use the symbols that are defined below. Please read the manual and pay attention to these sections. Failure to read this manual and its safety instructions is a misuse of the equipment and may lead to serious injury or death.



This is the safety alert symbol. It is used to alert you to potential personal injury hazards. Obey all safety messages that follow this symbol to avoid possible injury or death.



DANGER indicates a hazardous situation which, if not avoided, will result in death or serious injury.



WARNING indicates a hazardous situation which, if not avoided, could result in death or serious injury.



CAUTION, used with the safety alert symbol, indicates a hazardous situation which, if not avoided, could result in minor or moderate injury.



NOTICE is used to address practices not related to personal injury.

1. Safety

Safety Instructions

Our foremost concern is your safety and the safety of others associated with this equipment. We want to keep you as a customer. This manual is to help you understand safe operating procedures and some problems which may be encountered by the operator and other personnel.

As owner and/or operator, it is your responsibility to know what requirements, hazards and precautions exist, and to inform all personnel associated with the equipment or in the area. Safety precautions may be required from the personnel. Avoid any alterations to the equipment. Such alterations may produce a very dangerous situation where **SERIOUS INJURY** or **DEATH** may occur.

This equipment shall be installed in accordance with the current installation codes and applicable regulations which should be carefully followed in all cases. Authorities having jurisdiction should be consulted before installations are made.

Follow Safety Instructions

Carefully read all safety messages in this manual and safety signs on your machine. Keep signs in good condition. Replace missing or damaged safety signs. Be sure new equipment components and repair parts include the current safety signs. Replacement safety signs are available from the manufacturer.

Learn how to operate the machine and how to use controls properly. Do not let anyone operate without instruction.

Keep your machinery in proper working condition. Unauthorized modifications to the machine may impair the function and/or safety and affect machine life.

If you do not understand any part of this manual or need assistance, contact your dealer.

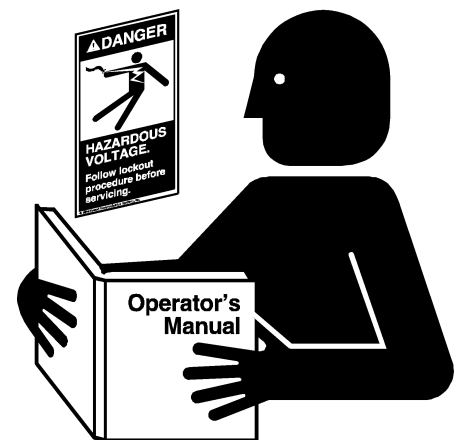

Read and Understand Manual

Operate Motor Properly

In an emergency, shut down the power source.

Turn OFF and lock out all power sources before performing any maintenance.

Do not operate electric motor equipped units until motors are properly grounded.

Disconnect power on electrical driven units before resetting motor overloads.

Do not repetitively stop and start the drive in order to free a plugged condition. Jogging the drive in this manner can damage the equipment and/or drive components.

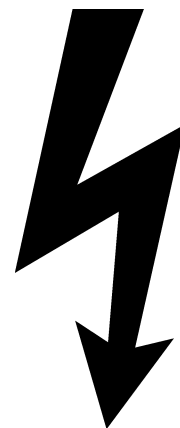

Electric Shock Hazard

Stay Clear of Moving Parts

Entanglement in rotating impeller arms will cause serious injury or death.

Keep all shields and covers in place at all times.

Wear close fitting clothing. Stop and lock out power source before making adjustments, cleaning, or maintaining equipment.

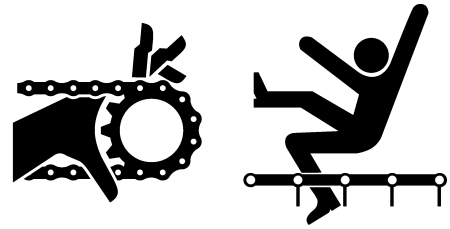
**Entanglement Hazard****Practice Safe Maintenance**

Understand service procedures before doing work. Keep area clean and dry.

Never lubricate, service, or adjust machine while it is in operation. Keep hands, feet and clothing away from rotating parts.

Keep all parts in good condition and properly installed. Fix damage immediately. Replace worn or broken parts. Remove any built up grease oil and debris.

**Maintain Equipment and Work Area****Prepare for Emergencies**

Be prepared if fire starts.

Keep a first aid kit and fire extinguisher handy.

Keep emergency numbers for doctors, ambulance service, hospital and fire department near your telephone.

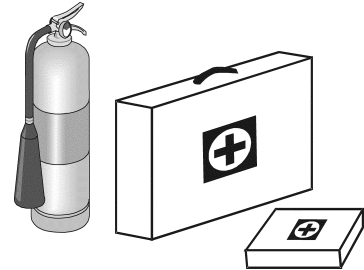
**Keep Emergency Equipment Quickly Accessible**

1. Safety

Wear Protective Clothing

Wear close-fitting clothing and safety equipment appropriate to the job.

Remove all jewelry.

Tie long hair up and back.

Wear safety glasses at all times to protect eyes from debris.

Wear gloves to protect your hands from sharp edges on plastic or steel parts.

Wear steel-toed boots to help protect your feet from falling debris. Tuck in any loose or dangling shoestrings.

A respirator may be needed to prevent breathing potentially toxic fumes and dust.

Wear a hard hat to help protect your head.

Wear appropriate fall protection equipment when working at elevations greater than six feet (6').

Eye Protection

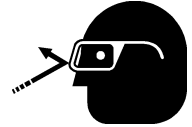

Gloves



Steel-Toed Boots



Respirator



Hard Hat



Fall Protection



Grain Bin Safety

The Chain Loop System is generally used to move grain into or from grain bins. **Be aware of the dangers inherit in grain bins.**



DO NOT ENTER A GRAIN BIN UNLESS POWER IS LOCKED OUT TO ALL BIN EQUIPMENT.



DO NOT ENTER A GRAIN BIN WHILE GRAIN IS BEING REMOVED. FLOWING GRAIN CAN TRAP, BURY AND CAUSE SUFFOCATION.



DO NOT ENTER A GRAIN BIN IF THE GRAIN HAS BRIDGED OR STOPPED FLOWING NORMALLY. THE GRAIN CAN COLLAPSE WITHOUT WARNING AND CAN TRAP, BURY AND CAUSE SUFFOCATION.

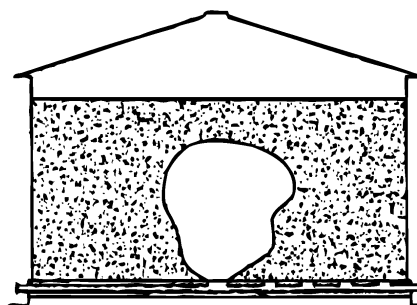
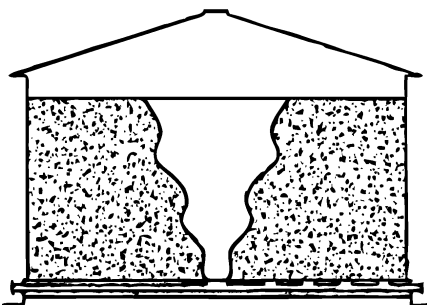

2. Decals





THE DECALS SHOWN ON THIS PAGE MUST BE DISPLAYED AS SHOWN

Replacements are available upon request. Write to the following address:

GSI Decals

1004 E. Illinois St.
Assumption, IL. 62510
Phone: 1-217-226-4421

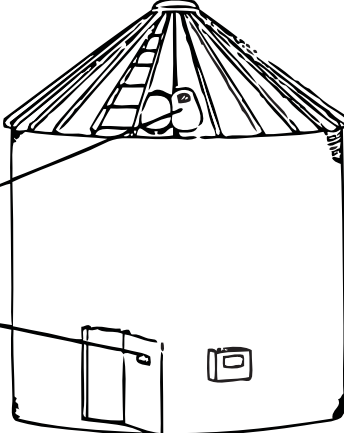
- NOTE:**
1. The decals on this page are not actual size.
 2. Keep all decals wiped clean at all times.
 3. All decals must be replaced if they are destroyed, missing, painted over or can no longer be read.

<p style="text-align: center;">NOTICE</p> <ol style="list-style-type: none"> 1. READ AND UNDERSTAND THE OPERATOR'S MANUAL AND ALL SAFETY INSTRUCTIONS. 2. DO NOT OPERATE WHILE UNDER THE INFLUENCE OF DRUGS OR ALCOHOL. 3. DO NOT OPERATE UNLESS ALL SAFETY EQUIPMENT, SWITCHES, GUARDS AND SHIELDS ARE SECURELY IN PLACE AND OPERATIONAL. 4. ALLOW ONLY TRAINED AUTHORIZED PERSONNEL IN THE OPERATING AREA. 5. ANY ELECTRICAL WIRING OR SERVICE WORK MUST BE PERFORMED BY A QUALIFIED ELECTRICIAN. IT MUST MEET ALL STATE AND LOCAL ELECTRICAL CODES. 6. DO NOT ALLOW CHILDREN IN THE AREA OF OPERATION. 7. KEEP HANDS, FEET AND CLOTHING AWAY FROM MOVING PARTS. 8. DISCONNECT AND LOCKOUT POWER BEFORE MAKING ANY ADJUSTMENTS OR PERFORMING ANY SERVICE WORK. 9. DISCONNECT POWER PRIOR TO RESETTING ANY MOTOR OVERLOAD. 10. MAKE CERTAIN ALL ELECTRIC MOTORS ARE GROUNDED. 11. REPLACE ALL WORN OR DAMAGED LABELS IMMEDIATELY. <p style="text-align: right;">DC-1379</p>	 <p style="text-align: center;">8107001</p>
<p>DC-1379</p> <p>This decal is provided in the Owner's Manual Packet. Place on the bin during installation.</p>	  <p style="text-align: center;">8107006</p>
 <p style="text-align: center;">DC-994</p>	 <p style="text-align: center;">DC-995</p>

Decal Placement

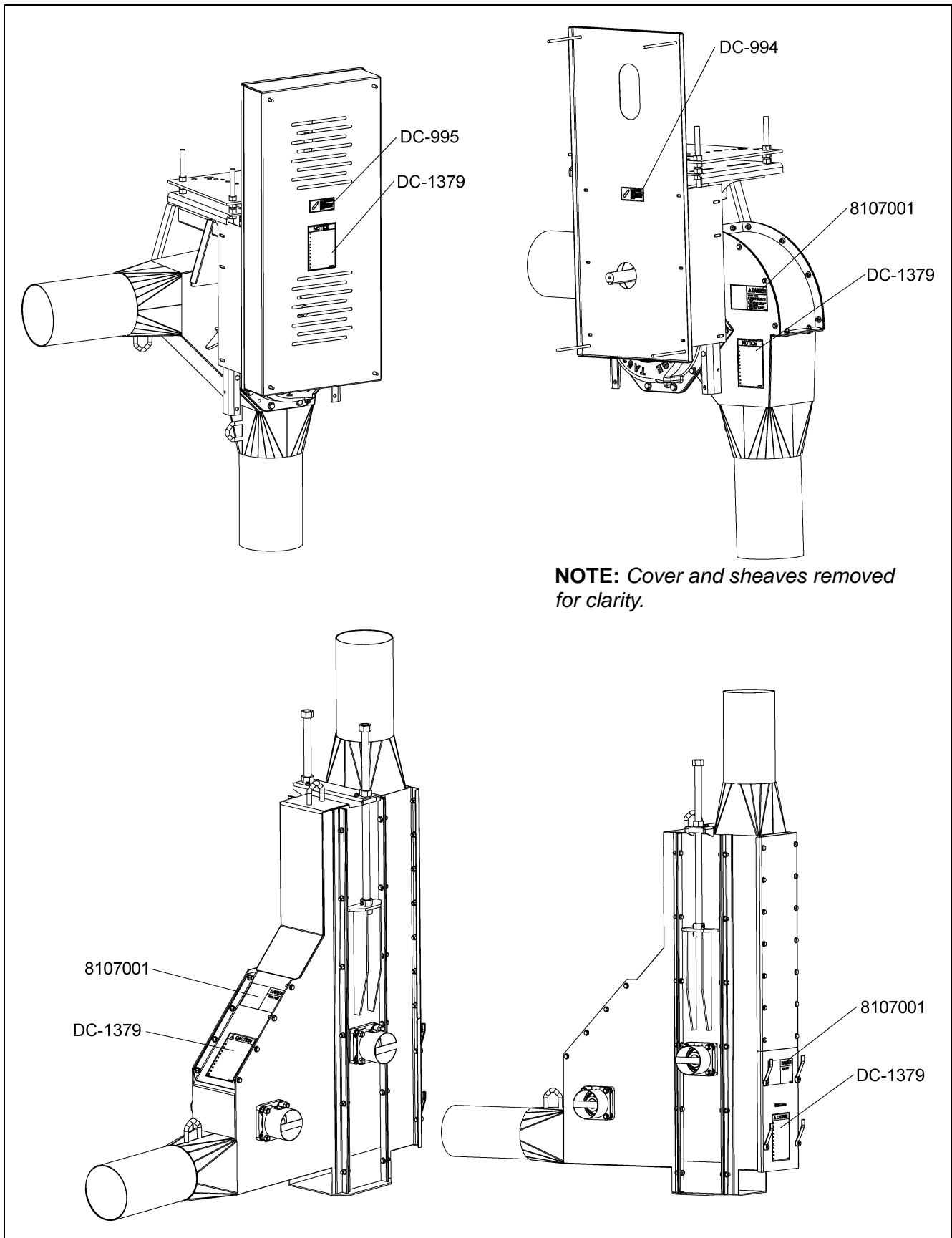

Decal Placement

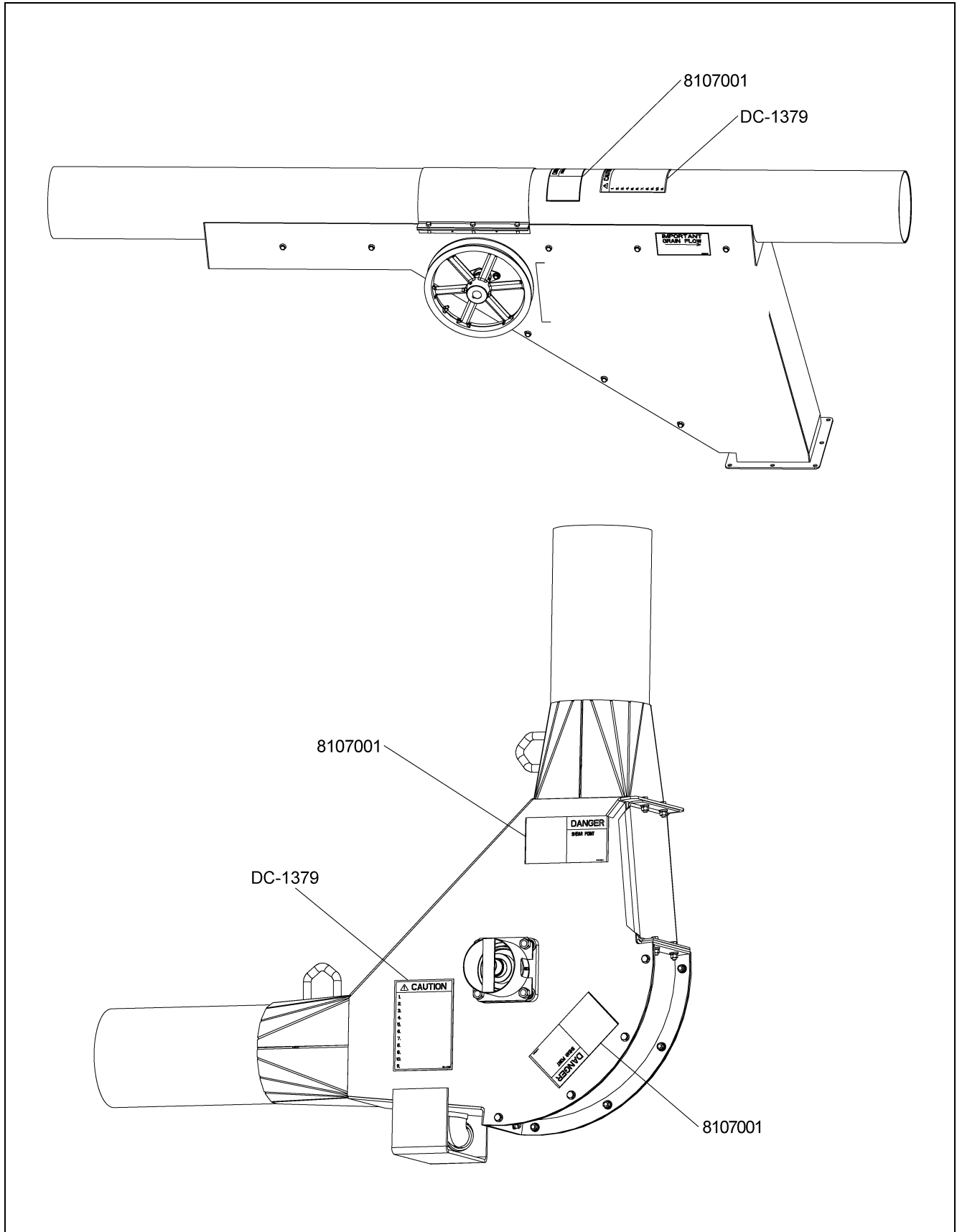

Chain Loop System Information

A Chain Loop System is a chain and paddle conveyor moving through a round housing. A loop system allows you to do total loading and unloading with a single drive. Chain Loop Systems will handle a wide range of free flowing materials. They are primarily intended for grain and grain products. They will move material into and out of grain storage structures, vehicles, dryers and other facilities with ease and gentleness. The Chain Loop System is well suited for blending materials while being transferred from one storage unit to another.

The height and length of the system is limited by the combined horsepower required to move the grain. The vertical Chain Loop System requires greater horsepower per foot, so the taller units will be more limited in the overall horizontal length. System lengths of several hundred feet are common. However, relatively small systems to accomplish more specific tasks are also available.

Chain Loop System Specifications

	8"	10"	12"
*Maximum capacity in BPH (Tons/Hr)	4000 (100)	6000 (150)	1000 (250)
Chain travel in FPM (Meters, Min)	325 (99)	325 (99)	400 (122)
Head shaft RPM	94	94	83
Corner housing thickness, galvanized (mm)	7 Ga. (4.8)	5 Ga. (4.8)	3/16" (4.8)
Galvanized tubing wall thickness (mm)	12 Ga. (2.7)	12 Ga. (2.7)	10 Ga. (3.47) 7 Ga. (5)
Paddle thickness (UHMW) (mm)	3/8" (9.5)	1/2" (12.7)	1/2" (12.7)
Corner shaft diameter (mm)	2" (50.8)	3" (76.2)	3-7/16" (87.3)
Conveyor chain	81XHH	81XHH	81XHH
Conveyor sprocket	16 Tooth	16 Tooth	22 Tooth
*Power requirements			
Per foot vertical (KW/M)	0.35 (0.86)	0.5 (1.22)	0.75 (1.84)
Per foot horizontal (KW/M)	0.08 (0.19)	0.11 (0.27)	0.18 (0.44)
Weight per foot lbs (KG/M)			
Empty	12 (17.9)	15 (22.3)	24 (35.8) 30 (44.7)
Full of 56 lb. per bu. material	28 (41.7)	40 (59.5)	59 (88) 65 (97)

* Clean dry grain

Final Inspection Check List

The Chain Loop System requires an inspection before start-up after the assembly is complete and before each use. The following are critical areas to be inspected.



1. *Make sure that the main power isolator is locked in the “OFF” position and that the only key is in the possession before removing any shields and inspection covers.*

2. Check all safety decals and replace any that are worn, missing or illegible. [See Pages 10-12](#) for decal part numbers and location.
3. Check for proper chain tension and adjust if necessary. [See Page 29](#) for full instructions.
4. Check that the discharge gates open and close completely. Remove the inspection cover from the top of the discharge gate and make sure that the gate is clean inside.
5. Check the lubricant level in the gear reducer at the drive corner. [See Page 17](#) for lubrication specifications.

NOTE: *The gear reducer is shipped dry and needs to be filled to the proper level before use.*

6. Check the condition of the drive belts and make sure that they are aligned and tensioned properly.
7. Check that the corner sprockets are centered in the housings. Realign the sprockets and tighten the set screws if necessary.
8. Check overall structural integrity of the Chain Loop System and make sure that all supports and components are secure.
9. Check to make sure that the chain moves freely (this is particularly important if the temperature is below freezing). Use a pipe wrench on the end of each of the corner shafts to manually move the chain.



10. *Make sure all shields and safety guards are in place before restoring power.*

Operating the Chain Loop System

The Chain Loop is generally used to transfer grain to or from storage bins. Grain can be fed into the system through an inlet dump hopper or through center or intermediate grain wells in the storage bins. Wells from more than one bin can be opened at the same time to blend the contents of different bins. The system is usually oriented vertically (with the tube running under the storage bins), or at an angle with the bottom tube running along the sides and the top tube running over the fill holes of the storage bins. Horizontal installations are also possible - check with your dealer for special gear reducer lubrication requirements for horizontal installations.

The Chain Loop System should always be run under partial load for a period of time to polish the tube walls before attempting to run at full load. This is especially true when breaking in a new system but equally important after being idle for a length of time. Observe the amp meter on the drive motor while running with a partial load until the amperage starts to decline. This is an indication that the tube walls have been polished enough to handle a larger load.

It is very important to avoid stopping the chain under a loaded condition. Never attempt to restart until the Loop System has been emptied of as much grain as possible.



Lock out the main power source before removing any inspection covers or shields necessary to empty the system.

Observe the following basic sequence for using the Chain Loop System to fill storage bins.

1. Open the discharge gate above the destination bin.
2. If available, open the discharge gate above a bin downstream from the destination bin to be used as an overflow.
3. Start the Chain Loop drive motor. Station an individual at the control box to observe the amp gauge of the drive motor.
4. Let grain flow into the inlet dump hopper. Open the flow control by adjusting the chains on the hopper a small amount at a time to make sure that the amperage does not exceed the capability of the drive motor. **NOTE:** *Some materials and grains such as soybeans flow very easily, so it is important to make sure that the center shield in the inlet hopper is adjusted low enough to prevent overloading the system.*
5. Let the Chain Loop run until the system is empty.
6. Close the discharge gates and the dump hopper flow control when through filling.



7. *Shut down the drive motor.*
8. *Make sure to lock out the power source before leaving the work area.*

4. Operation

Operating the Chain Loop System (Continued)

Observe the following basic sequence for using the Chain Loop System to transfer grain from storage bins.

1. Open the discharge gate above the withdrawal bin.
2. Open the discharge gate above the destination bin or truck-loading spout.
3. Start the Chain Loop drive motor. Station an individual at the control box to observe the amp gauge of the drive motor.
4. Open the slide gate under the withdrawal bin a little at a time to make sure that the amperage does not exceed the capability of the drive motor.
5. Close the discharge gate above the destination bin or truck when full. **DO NOT SHUT DOWN THE CHAIN LOOP DRIVE MOTOR AT THIS TIME.**
6. Close the slide gate under the withdrawal bin.
7. Run the Loop System until all remaining grain in the tube has been returned to the withdrawal bin.



8. Shut down the drive motor.

9. Make sure to lock out the power source before leaving the work area.

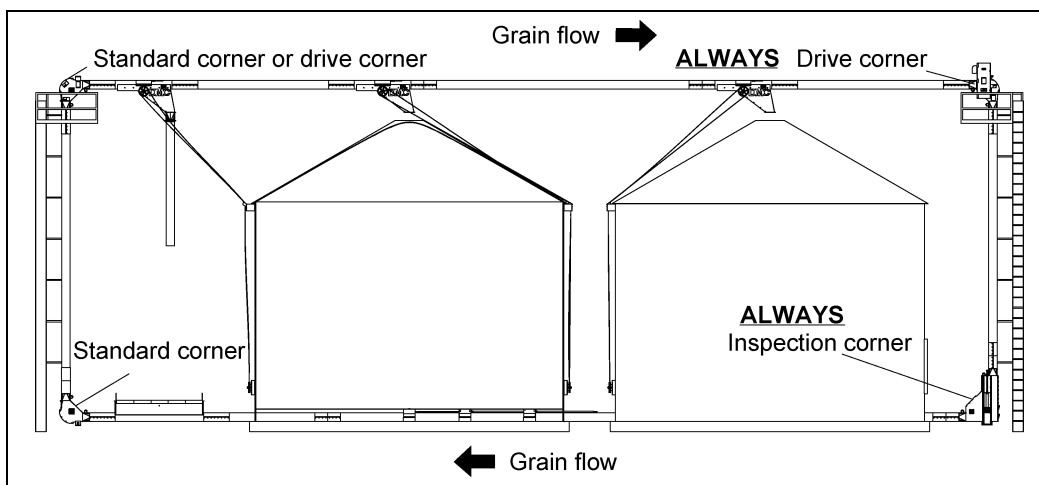

Figure 4A

A sweep auger may be placed in the bin after all the grain has been removed that will gravity-flow through the center well. Shut down and lock out all power to the Chain Loop System before installing the sweep auger.

If intermediate bin wells are being used, they should be opened after grain has stopped flowing into the center well and before the sweep auger is placed in the bin. (See Figure 4B.) Shut down and lock out the Chain Loop System before installing the sweep auger.

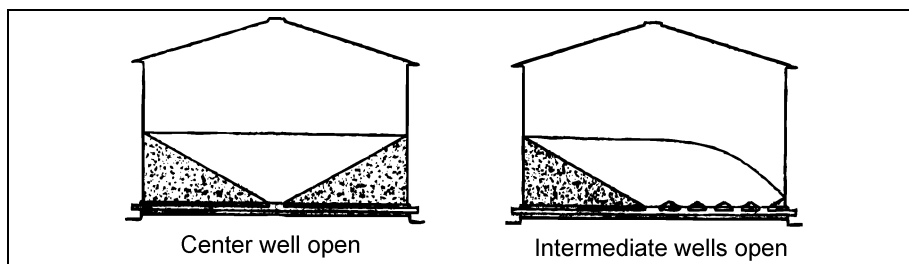

Figure 4B

Maintenance



Lock out the main power source before performing any maintenance or service inspections.

Dodge Gear Reducer

Use the information that is on the gear reducer nameplate, the warning tags and the Dodge instruction manual that is included with the Chain Loop manual to determine specific maintenance instructions for the gear reducer used on the system. When referring to the Dodge manual, note that the reducer is mounted in the “D” position on the Chain Loop.

NOTE: *The gear reducer is shipped dry and must be filled to the proper level before use.*

Use a high-grade petroleum base rust and oxidation inhibited SAE 90 weight gear oil for ambient temperatures from 15°F to 125°F (-10°C to 52°C). Oils with an “EP” additive are not recommended for average conditions (see the lubrication section of the Dodge manual). Use the check oil plug for determining the correct amount of oil; too much oil will cause overheating and too little will cause bearing and gear failure. The approximate quantity of oil for each reducer size is:

Model	TA3203H	4.0 qt	(3.80L) - for 15-20 HP motors
	TA4207H	7.3 qt	(6.90L) - for 25-30 HP motors
	TA5215H	12.9 qt	(12.2L) - for 40 HP motors
	TA6307H	15.8 qt	(15.0L) - for 60 HP motors

The oil should be changed at the beginning of every harvesting season if the Chain Loop is used for seasonal grain handling. It should be changed after 2500 hours of operation or every 6 months if used under average industrial conditions. The oil should be changed more frequently if used under extreme operating conditions such as large changes in ambient temperatures, dust, dirt, chemical particles, chemical fumes or oil sump temperatures above 200°F.

Drain the reducer, clean the magnetic plug and flush with kerosene before refilling with new oil.

Drive Belts

Check to make sure that drive belts are tensioned and aligned properly. Use a straight edge to check the alignment with the motor and reducer sheaves. Adjust all the motor tensioning rods equally to keep the motor shaft parallel to the reducer shaft.

Vent Elbow Installation Instructions

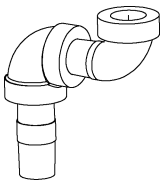

8101333 - 1/2" Vent elbow assembly
(Used on TA4, TA5 and TA6 reducers in “D” position)

8101335 - 3/8" Vent elbow assembly
(Used on TA3 reducers in “D” position)

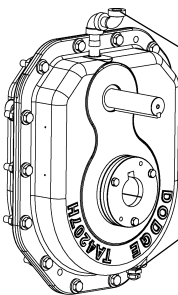

To install vent elbow assembly:
(Reducer is shown in “D” position - Input shaft at the top)

- Remove magnetic drain plug from the top of the reducer and replace with the proper vent elbow assembly.
- Remove vent plug from the bottom of the reducer and replace with the magnetic drain plug from the top.
- Install the vent plug in the top of the vent elbow assembly.

5. Management and Maintenance

Chain and Paddles

Check for proper chain tension. Open the inspection door at the inspection corner and check chain tension by pulling the bottom edge of a paddle by hand. The paddle tip should not move more than 3/4" when the chain is properly tensioned. [\(See Page 29.\)](#)

The Chain Loop chain has connecting links spaced every 10'. Check these links to make sure that they are securely fastened and that the cotter pins are bent back correctly. [\(See Figure 6M on Page 30.\)](#)

Check the lock nuts used to fasten the paddles to the chain brackets. They should be tightened to a torque specification of 20 ft. lbs. (2.8 KG-M or 26 N-M).

Adjust the chain tension by loosening the locking jam nuts on the adjusting screw and turning the screw to move the inspection corner sprocket. Turning the adjusting screw clockwise will tighten the chain and turning it counterclockwise will loosen the chain. Remove chain links if there is not enough travel in the adjusting screw to tighten the chain. Adjust each side equally to keep the sprocket shaft square with the corner housing. [\(See Figure 6N on Page 31.\)](#)

Spray a light coating of oil on the chain after a season of use.

Corner Shaft Bearings

The bearings for the corner sprockets are sealed bearings and require only a small amount of multi-purpose grease every 50 hours. Check bearings for wear and that the locking collars are secure.

Corner Sprockets

Inspect the condition of corner sprockets for teeth wear and that they are centrally aligned in each of the corner housings.

It is expected that an experienced millwright or contractor will provide the supporting structure and do the installation of a Chain Loop System including the electrical wiring and the control box.

All electrical wiring and controls should be in accordance with local regulations (BS767: 1992 or the National Electric Code).

NOTE: *It is recommended that an amp meter for the drive motor be installed close to the inlet hopper so an operator can easily monitor and avoid overloading the system.*

The supporting structure needs to comply with local wind loads and soil supporting requirements as well as support the weight of the Chain Loop System. Component weights full of grain are:

System Size	Tube (Full)	Discharge Gate	Standard Corner	Drive Corner
8"	29 lbs/ft (43.1 KG/M)	411 lbs. (187 KG)	342 lbs. (155 KG)	1103 lbs. (502 KG)
10"	40 lbs/ft (59.5 KG/M)	533 lbs. (242 KG)	489 lbs. (222 KG)	1394 lbs. (634 KG)
12" 10 Gauge	59 lbs/ft (88 KG/M)	1024 lbs. (466 KG)	919 lbs. (418 KG)	2406 lbs. (1094 KG)
12" 7 Gauge	65 lbs/ft (97 KG/M)	1084 lbs. (493 KG)	933 lbs. (424 KG)	2420 lbs. (1101 KG)

NOTE: *Each calculation includes the respective chain.*

A layout should be drawn to show the exact location of grain bins, inlets, outlets, the control box, outlet control kits, the power source and the supporting structure. The layout should consider future expansion, the ability to mix grains from several locations, the grain direction, the operation of slide gates, the use of other conveyors to fill or unload bins and whether the Chain Loop tube is under the center of or beside the grain bins. Chain Loop Systems are provided with one (1) or two (2) drive corners depending on the power requirements of each system. Drive corners are always located at the upper corners, and the drive corner for single drive systems must be located at the far end of the top chain run. This will allow the drive corner to pull grain up from the loading hopper and across the top to the storage bins. **The inspection corner is always located on the ground furthest from the loading hopper. This allows proper chain tensioning throughout the system.** (See Figure 4A on Page 16.)

It is important to slide components together tightly and to have the clamping band centered on the joint before tightening the bands. All cuts should be made square and the inside diameter chamfered to ensure that the ends butt together tightly during assembly. Even small gaps left in the tubing system during assembly will gradually close during operation of the Chain Loop causing the chain to require frequent inspection and tightening. (See Page 21.)

General guidelines to consider are:

1. The Chain Loop will move grain in one direction only; it is not reversible.
2. Provide room for service and maintenance at each of the corners and discharge gates.
3. Avoid having any part of the system under grade to eliminate water accumulation problems.
4. Provide adequate footings for solid supporting structures.
5. Minimize the loaded distance by placing the inlet hopper as close to the vertical tube as possible.
6. There can be no twist in the chain/paddles. The opening should be oriented so that the open side of the paddle will pass across the sprockets.

6. Installation

System Size	Vertical Factor	Horizontal Factor
8"	0.35 HP/loaded foot (0.86 Kw/M)	0.08 HP/loaded foot (0.19 Kw/M)
10"	0.50 HP/loaded foot (1.22 Kw/M)	0.11 HP/loaded foot (0.27 Kw/M)
12"	0.75 HP/loaded foot (1.84 Kw/M)	0.18 HP/loaded foot (0.44 Kw/M)

The system should be designed to minimize the distance grain must be moved. The example shows the dump hopper located next to the vertical tube. If it were located on the other side of the grain bins then the system would have to move grain that much farther before taking it up and over to the discharge gates.

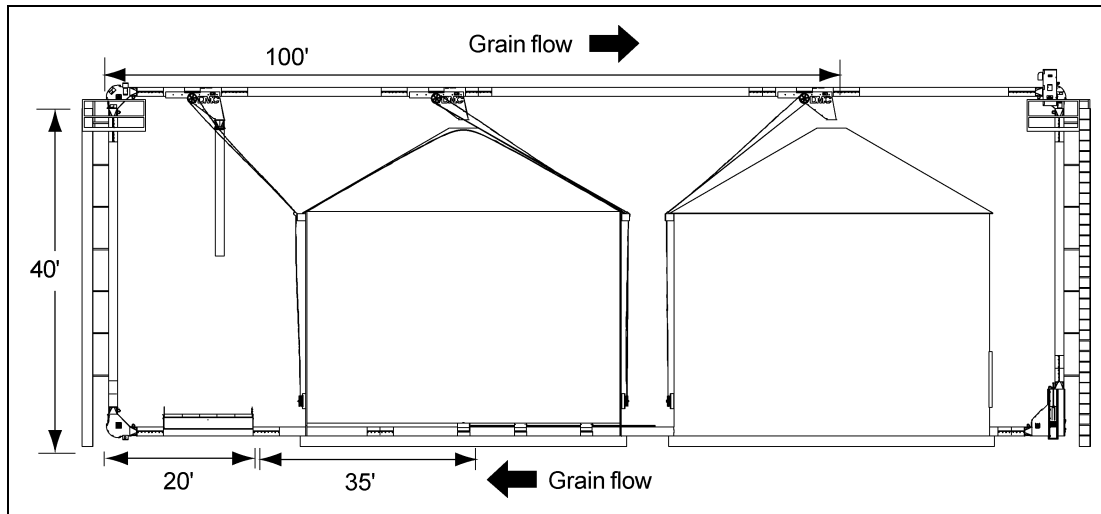

Figure 6A

This example illustrates a system and the power requirements for different functions of a Chain Loop System.

If the main requirement is maximum filling rate, then the motor size for this 8" system would be:

$$\begin{aligned}
 &0.35 \text{ HP/ft} \times 40 \text{ vertical ft.} &&= 14 \text{ HP plus} \\
 &0.08 \text{ HP/ft} \times (20 + 100 \text{ horizontal ft.}) &&= \underline{9.6 \text{ HP}} \\
 &&&= 23.6 \text{ (Use a 25 HP motor)}
 \end{aligned}$$

If the requirement is maximum flow rate while moving grain from bin to bin as well as a maximum filling rate, then the motor size would be:

$$\begin{aligned}
 &0.35 \text{ HP/ft} \times 40 \text{ vertical ft.} &&= 14 \text{ HP plus} \\
 &0.08 \text{ HP/ft} \times (35 + 20 + 100 \text{ horizontal ft.}) &&= \underline{12.4 \text{ HP}} \\
 &&&= 26.4 \text{ (Use a 30 HP motor)}
 \end{aligned}$$

Tube and Corner Assembly

Lay the sections out in order so as to determine what portions to assemble prior to actual placement in the system.

When cutting tubes to exact length, the ends must be cut square and any burrs on the ends must be removed by chamfering the inside diameter. Join tube and corner components together with connecting bands. Slide the tube sections tight together and space the connecting band in equal amounts on both parts of the connection. Tighten the bolts in the band.

Fasten the discharge in place within the tube with connecting bands.

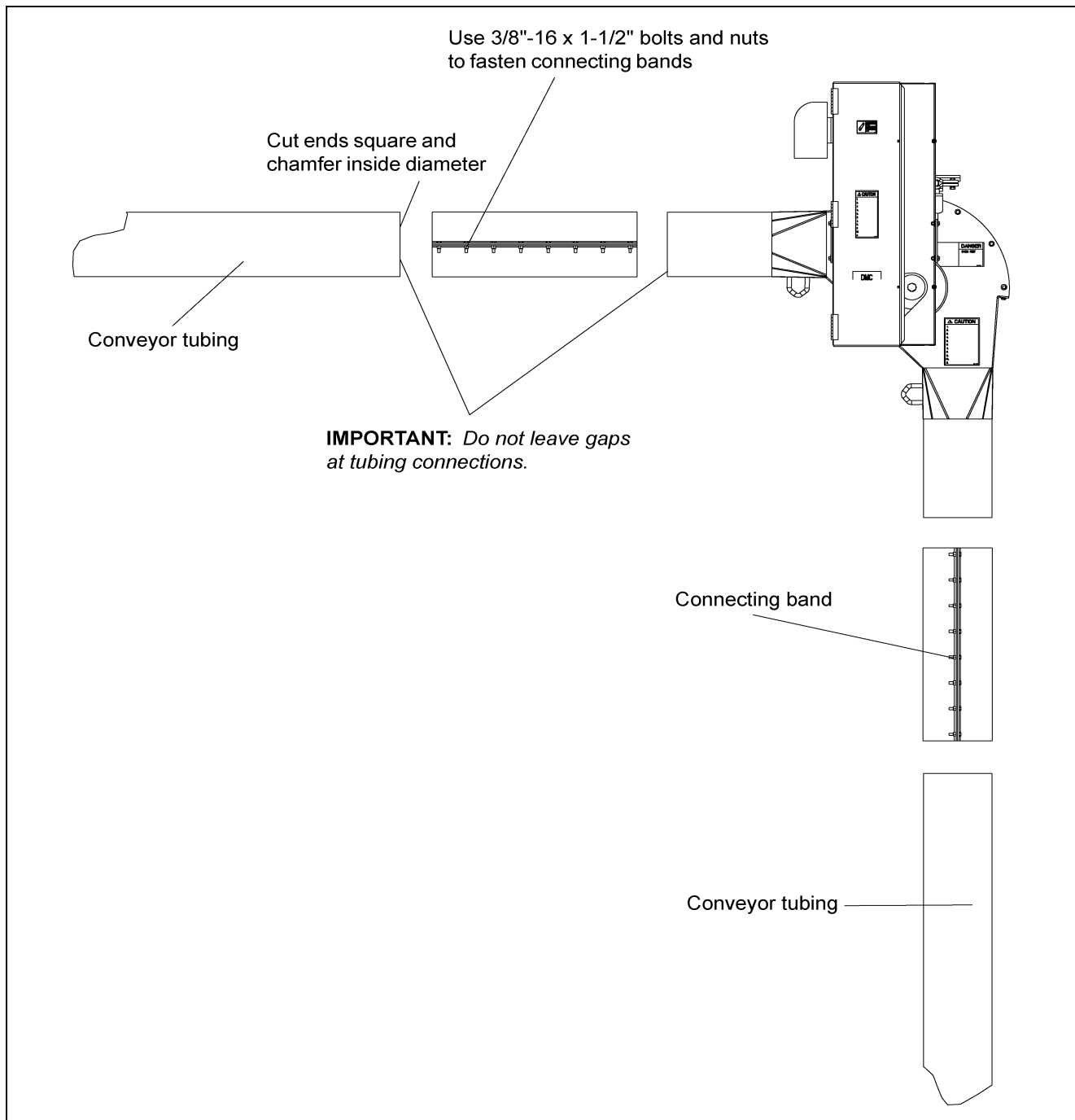

Figure 6B

6. Installation

Drive Assembly

The Chain Loop System is powered by an electric 1750 RPM motor.

IMPORTANT: Use the proper size motor to ensure satisfactory operation. Too small of a motor will not supply the horsepower required to achieve capacity and damage to the motor may occur. Too large of a motor may cause high stress on components resulting in shorter life. See Page 13 for motor size specifications.

IMPORTANT: Use the motor sheave furnished. If other size sheaves are used or substituted, improper chain speed and unsatisfactory operation will result.

Mount the sheaves as close to the belt guard back as possible. Align sheaves by using a straight edge, placed across the outer faces of both sheaves. Secure in place using taper lock bushing. Be sure drive keys are properly installed. Check sheave alignment again after sheaves are secured to shafts.

Install the belts onto the sheaves and set belt tension. To tighten belts, turn the 3/4" nuts on the motor mount rods to raise the motor mount assembly. Raise all the rods the same distance so the motor mount assembly is parallel with the top.

Check that all fasteners are tightly secured. Close and fasten belt guard.



Keep all safety shields and devices in place.

The gear reducer is shipped without oil. It is necessary to add the proper amount of oil before running. Use a high grade petroleum base, rust and oxidation inhibited R and O gear oil. Follow the instructions on the reducer name plate, warning tags and in the installation manual attached to the reducer.

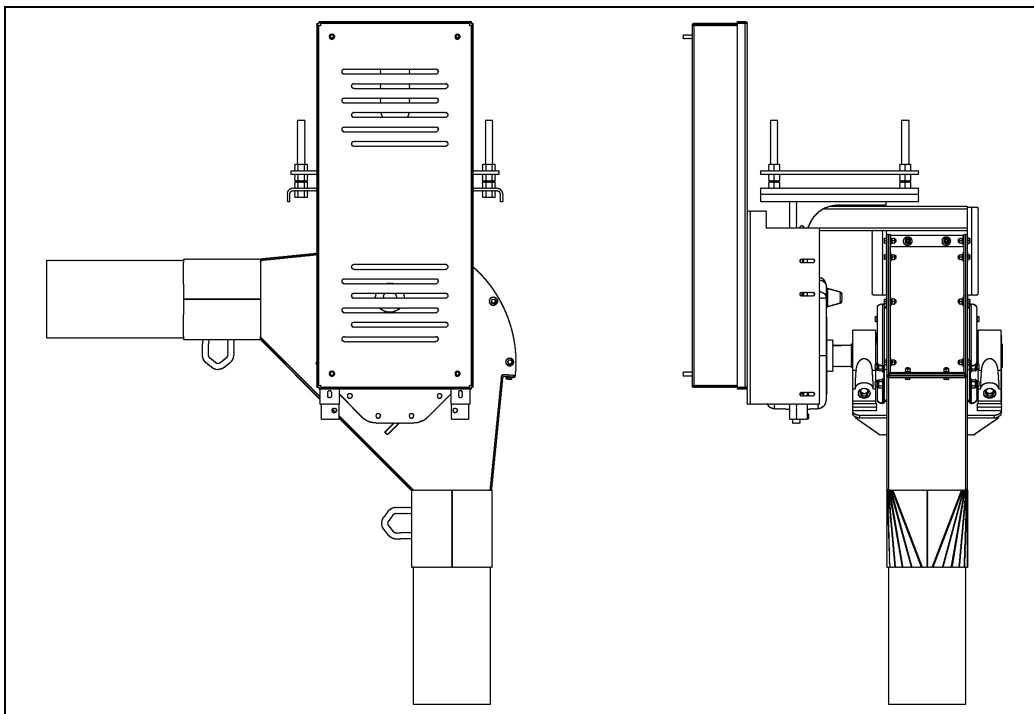

Figure 6C Sample Drive Assembly

Unit Size	8"	10"	12"
Recommended Chain Speed	325	325	400
Corner Shaft RPM	93	93	83

Chain Loop Torque Arm Repair Kit



Secure the motor mount from both sides to prevent the drive unit from pivoting either direction on the shaft.

NOTE: Motor mount and belt guard removed for clarity.

Attach both torque plate assemblies to each side of the gear reducer using the bolts provided. Re-use the lock washer and hex nut provided with the gear reducer. (See Figure 6D.)

NOTE: Leave the hardware loose to allow for ease of assembly.

TA3 - 3/8"-16 Bolt

TA4 and TA5 - 1/2"-13 Bolt

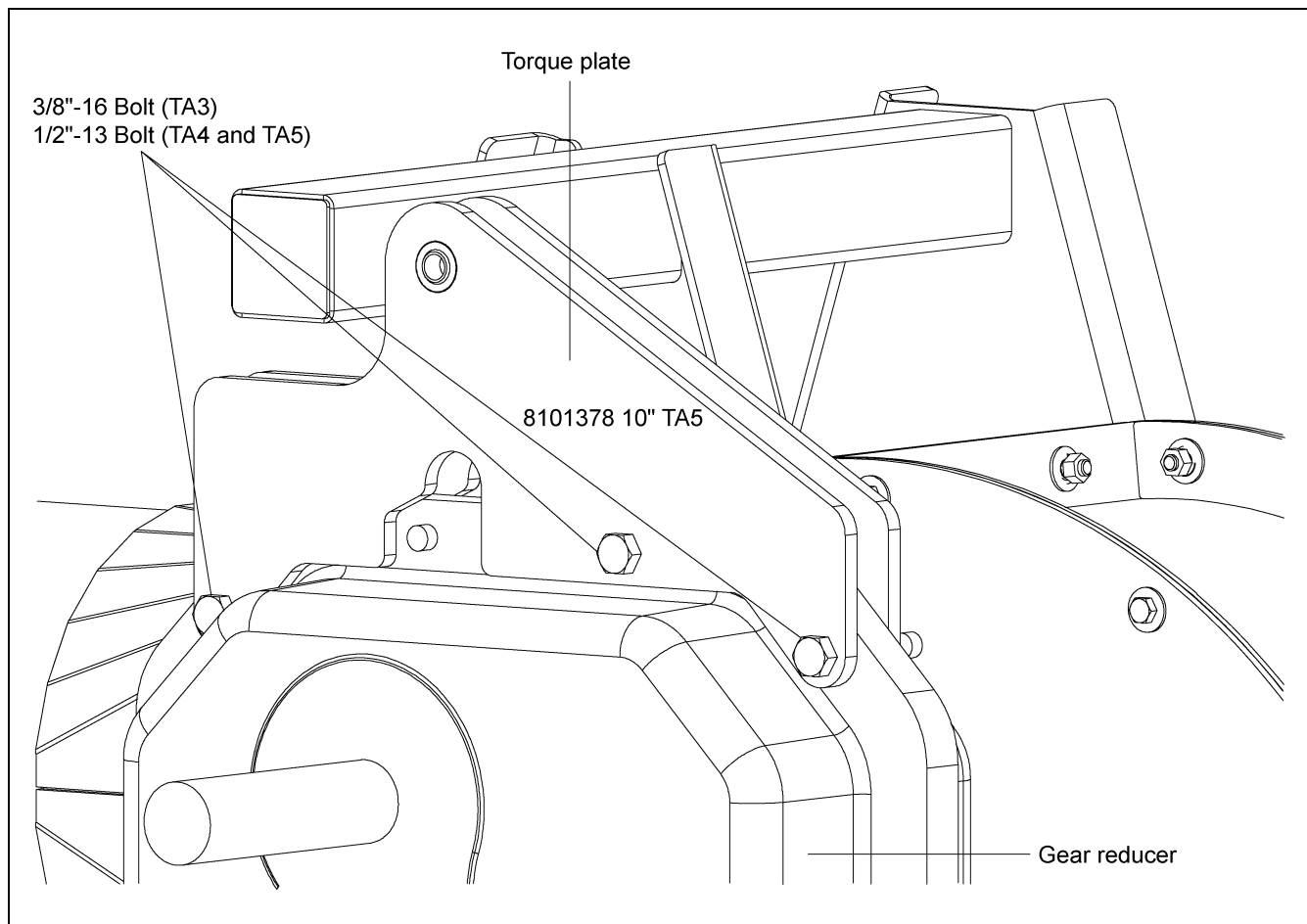

Figure 6D

6. Installation

Chain Loop Torque Arm Repair Kit (Continued)

Place the C-clamp bracket to the back side of the square tubing. (See Figure 6E.)

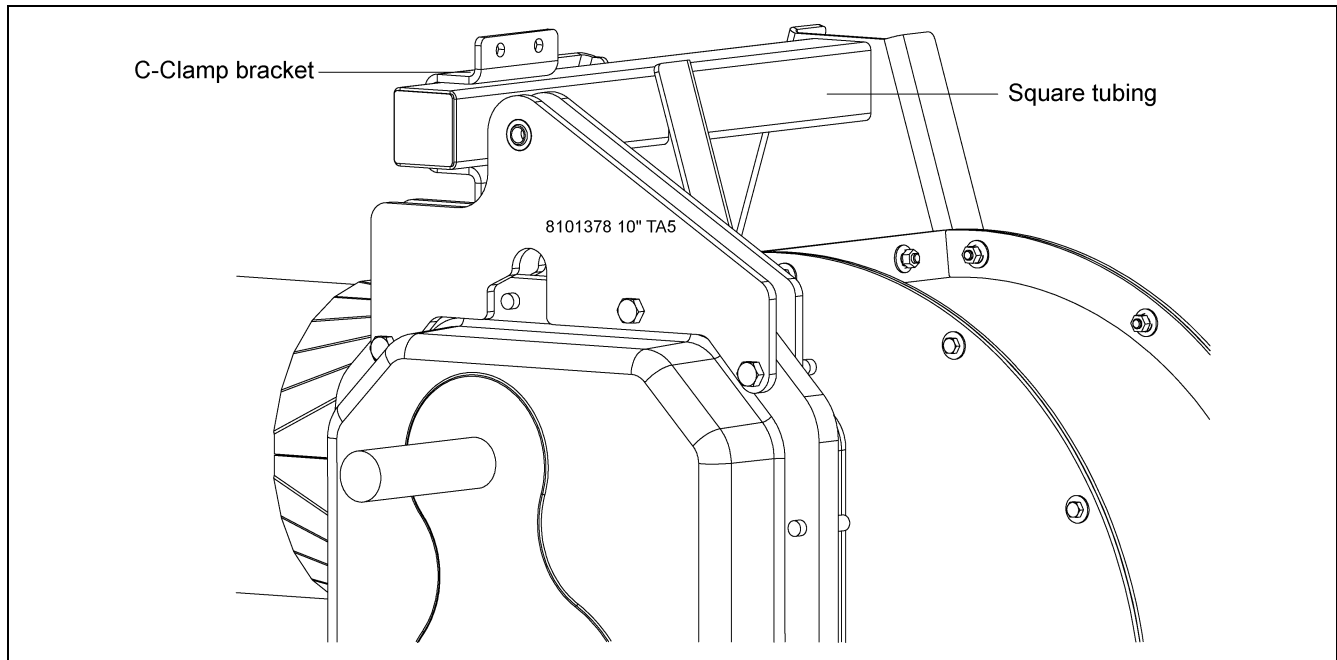

Figure 6E

Place the torque plate anchor bracket between the torque plate assemblies and attach it to the C-clamp using the 3/8"-16 hardware. (See Figure 6F.)

NOTE: Leave the hardware loose to allow for ease of assembly.

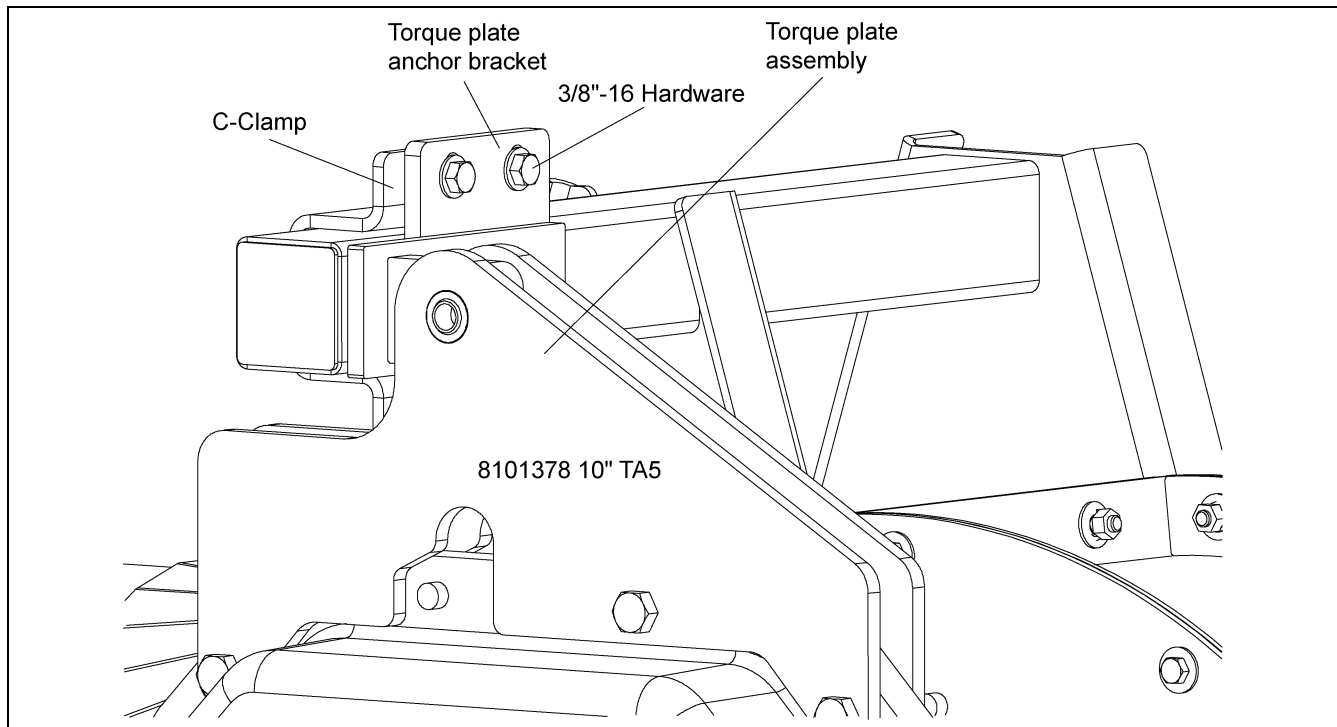

Figure 6F

Chain Loop Torque Arm Repair Kit (Continued)

Attach the torque plate anchor bracket to the torque plates using the two (2) 1/2" flat washers, shoulder bolt and 3/8"-16 nylock nut.

Tighten the hardware attaching the torque plate assemblies to the gear reducer after tightening the shoulder bolt hardware. (See Figure 6G.)

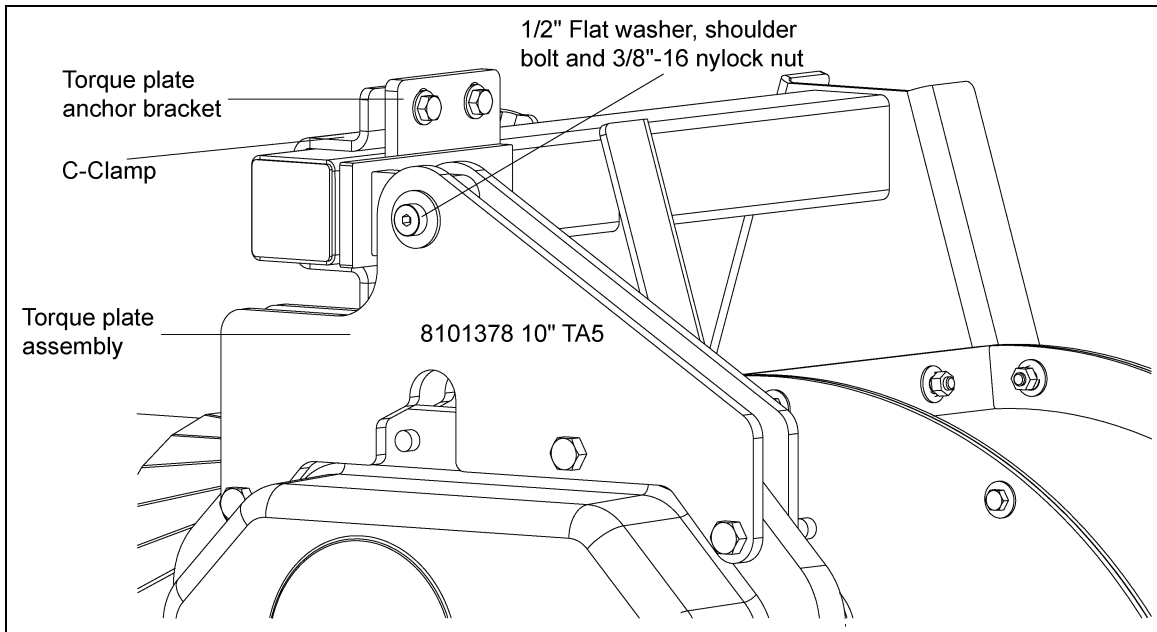

Figure 6G

Move the torque plate anchor bracket on the square tube so the torque plate assemblies are aligned vertical. Once aligned, the 3/8"-16 hardware attaching the torque plate anchor bracket to the C-clamp can be tightened. (See Figure 6H.)

NOTE: Washers must be on the outside of each torque plate assembly.

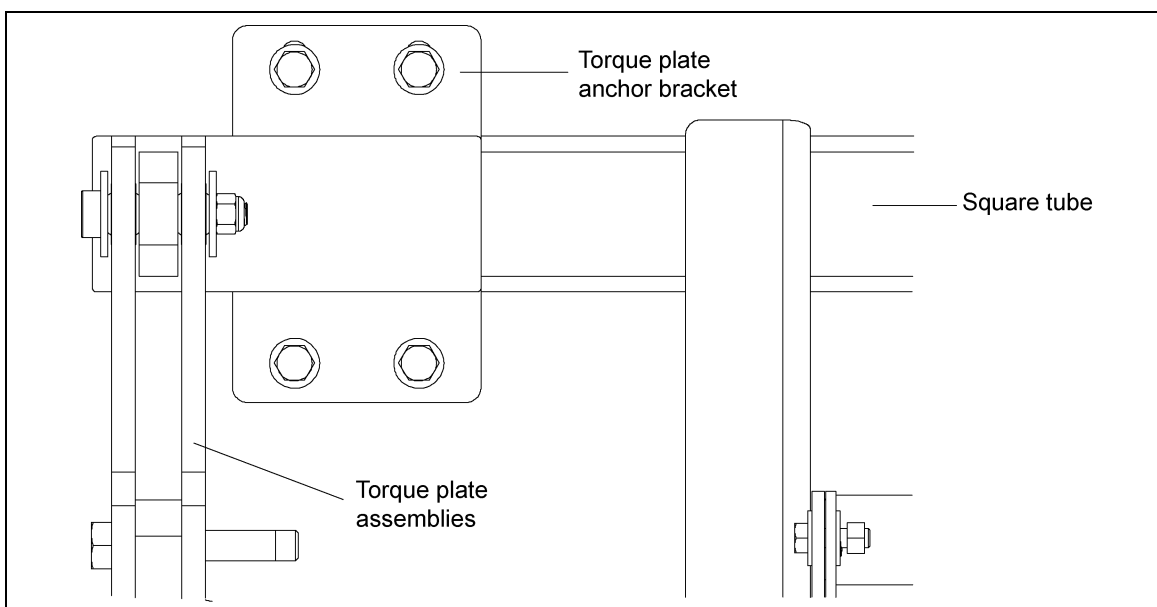

Figure 6H

Drive Box Assembly Instructions

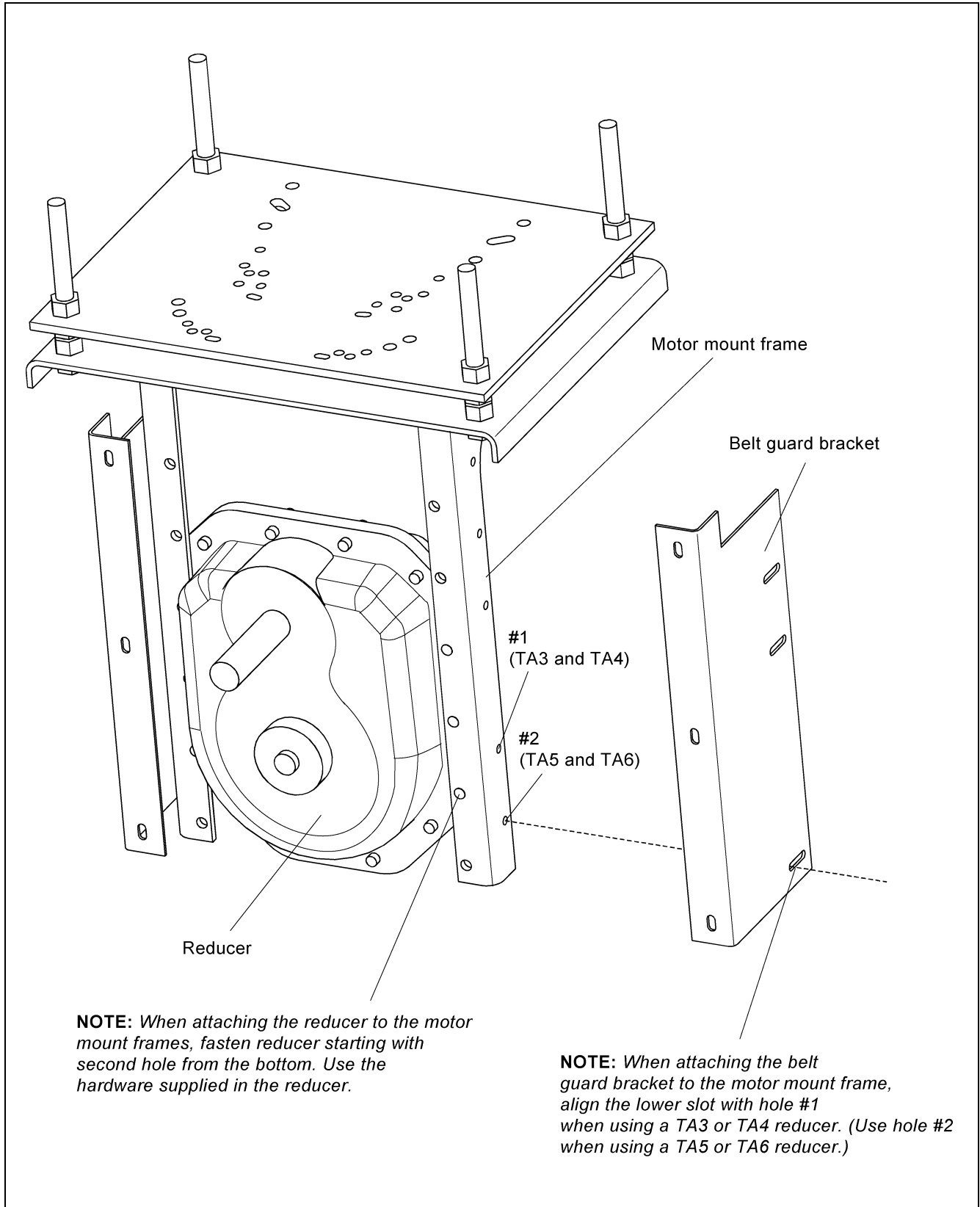

Figure 6I

Discharge with Gate Assembly

The discharge unit includes an 8' long section (12' long in 12" system). Locate the outlet of the discharge in the desired location. It may be necessary to cut exact lengths of other tube conveyor sections to locate the discharge unit in its proper place. The discharge with gate is designed for chain travel in only one direction. Make sure it is oriented properly by comparing the appearance to the diagram or referring to the decal on the discharge unit. Operation in the wrong direction can cause paddle damage.

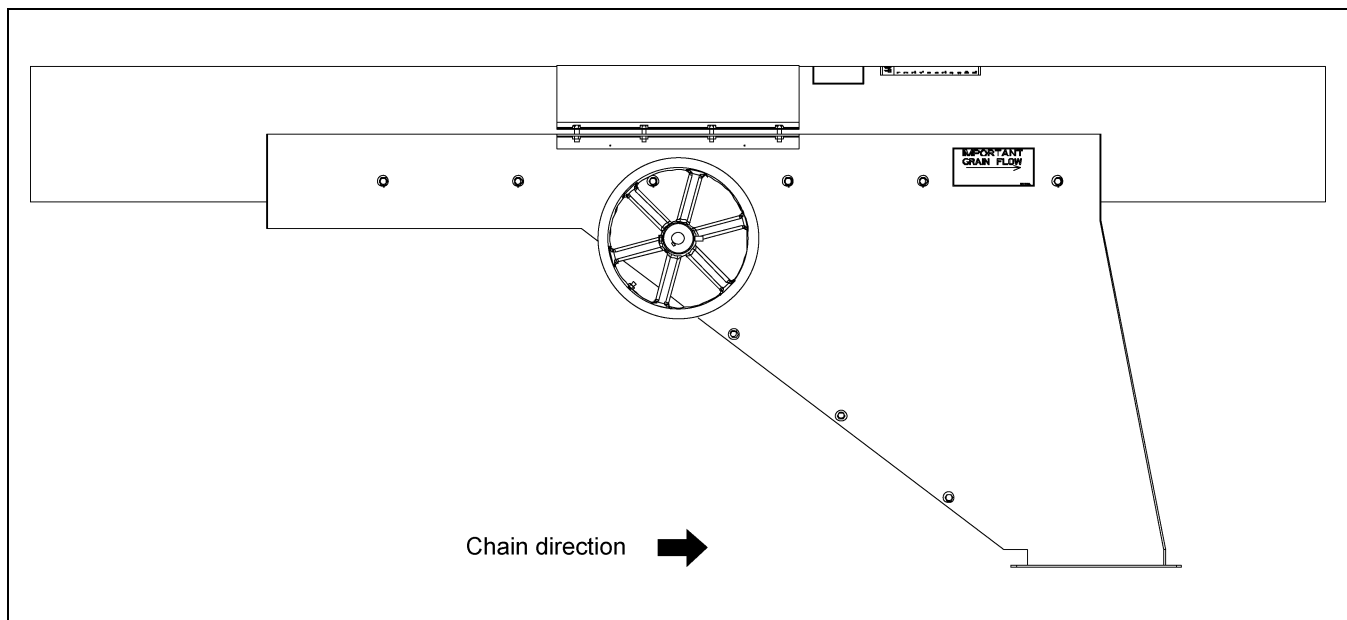

Figure 6J

When cutting tubes to exact length, the ends must be cut square and any burrs on the ends must be removed by chamfering the inside diameter. Join tube and discharge gate together with connecting bands. Slide the tube sections tightly together and space the connecting band in equal amounts on both parts of the connection.

Bin well installation for Chain Loop Systems installed under a row of grain bins.

Position the center bin well so that the bin sweep pivot is at the center of the bin and on top of the Chain Loop tube. Intermediate wells may be placed on the tube between the center and bin wall if desired.

Use [Figure 6K on Page 28](#) for minimum spacing requirements and as a guide to mark and cut the openings for the wells in the tube.

NOTE: Do not cut the opening with the chain and paddles inside the tube or they may be damaged.

The control pipe for the center well (1/2" pipe) should fit inside the pipe used for the intermediate wells (1" pipe). With the center and intermediate wells closed, drill a hole through both control pipes so that a bolt can be used to lock both pipes together. This will allow both slide gates to be operated together.

Open the slide gate in the center well and withdraw grain until no more flows. Close the center well slide-gate and place the bolt in the hole drilled through both control rods. The intermediate well slide-gates can now be operated with the center well.

6. Installation

Unload Well Installation

General Information

Observe the minimum spacings shown in the illustration below. (See Figure 6K.) Wells should be positioned on the tube so that the gates will open when control pipes are pulled out and away from the center of the bin.

A control pipe kit may be ordered from your dealer. For the center well, use 1/2" SCH. 40 pipe (-7/8" O.D.). For the intermediate well(s) use 1" SCH. 40 pipe (-1 3/8" O.D.). It may be necessary to support the unload well(s) and/or discharge tube from below with blocks or other material.

Consult the manufacturer of the bin floor for information on cutting openings in the floor for unload wells, for sealing around unload wells and for proper support of the floor around the unload wells and discharge tube.

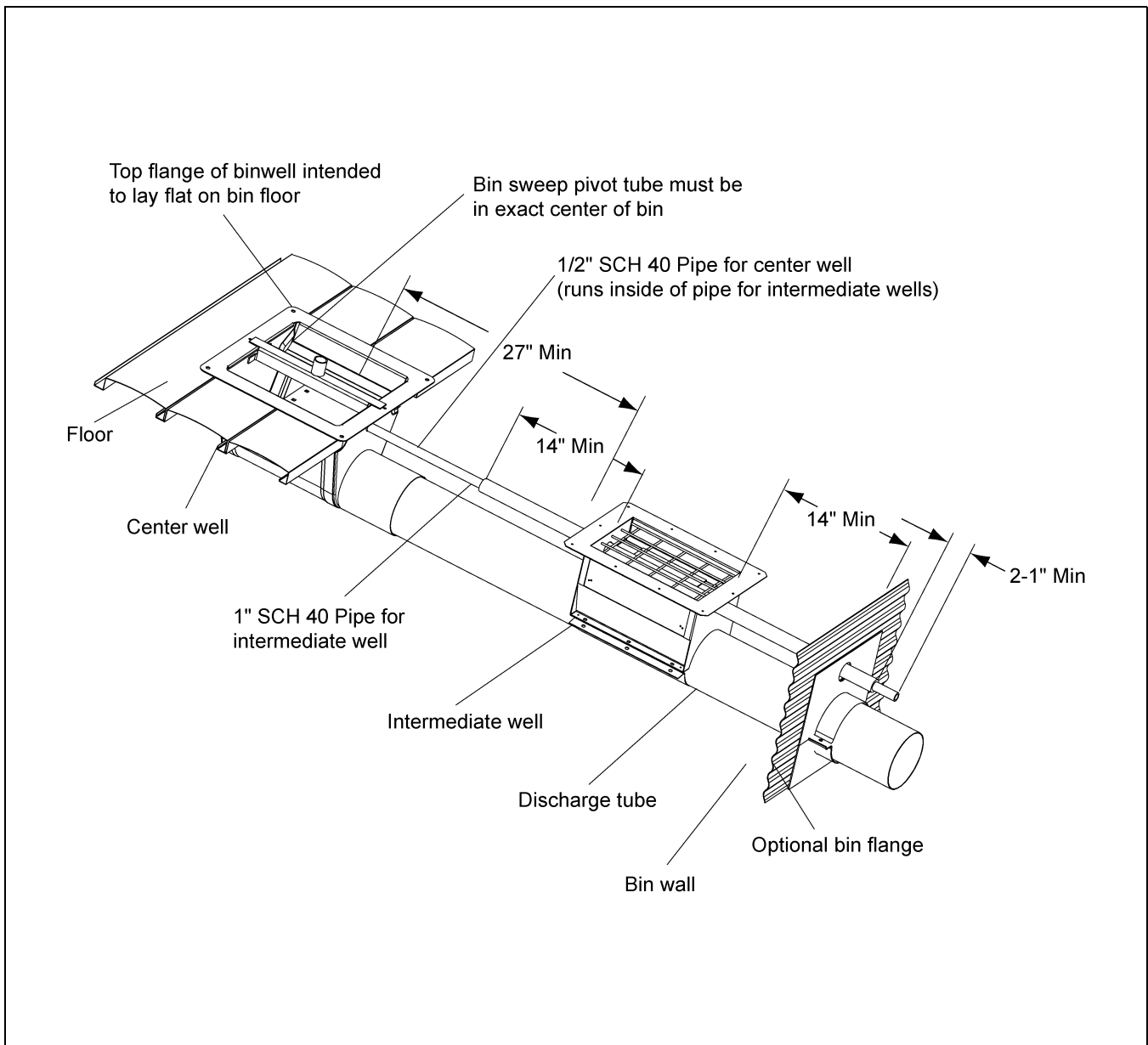

Figure 6K

Chain and Paddles

The paddles are attached to the chain with 5/16" x 1" serrated flange bolts, flat washers and locking nuts. Make sure that the slots in the chain paddle brackets are oriented as shown in [Figure 6M on Page 30](#). The head of the bolt should be inside the "V" shaped chain paddle bracket and the washer and nut should be against the face of the plastic paddle. Make sure all hardware is tightened properly to a torque of 20 ft. lbs.

The chain is shipped in 10' lengths and needs to be spliced as shown in [Figure 6M on Page 30](#). Make sure to bend the ends of the cotter pins as shown to prevent them from working loose and causing the chain to break.

Use an electrical fish tape or wire to pull the chain through the tube assembly. **It is possible for the chain to twist a full 360° during this process.** Visually check the chain through open inspection covers at the discharge gates and openings for wells to make sure that this has not happened.

Adjust the tightening screws in the inspection corner all the way up and connect the final chain link through the access door in the inspection corner after removing as much chain slack as possible. Tighten the chain by turning the adjusting screws clockwise; adjust each side equally to keep the sprocket shaft square with the housing. Remove chain links if there is not enough travel in the adjusting screw to tighten the chain. Make sure that the sprocket shaft is square to the housing by measuring the shaft position on both sides of the housing. (See [Figure 6N on Page 31](#).)

The chain should be tightened until the paddles are nearly rigid on the chain. The tips of the paddles should only move 3/4" when grabbed and pulled by hand.



Make sure all shields and safety guards are in place before restoring power.

Check and re-tension the chain after the system has been trial run while empty.



Turn OFF and lock out the main power source BEFORE removing any inspection covers or shields.

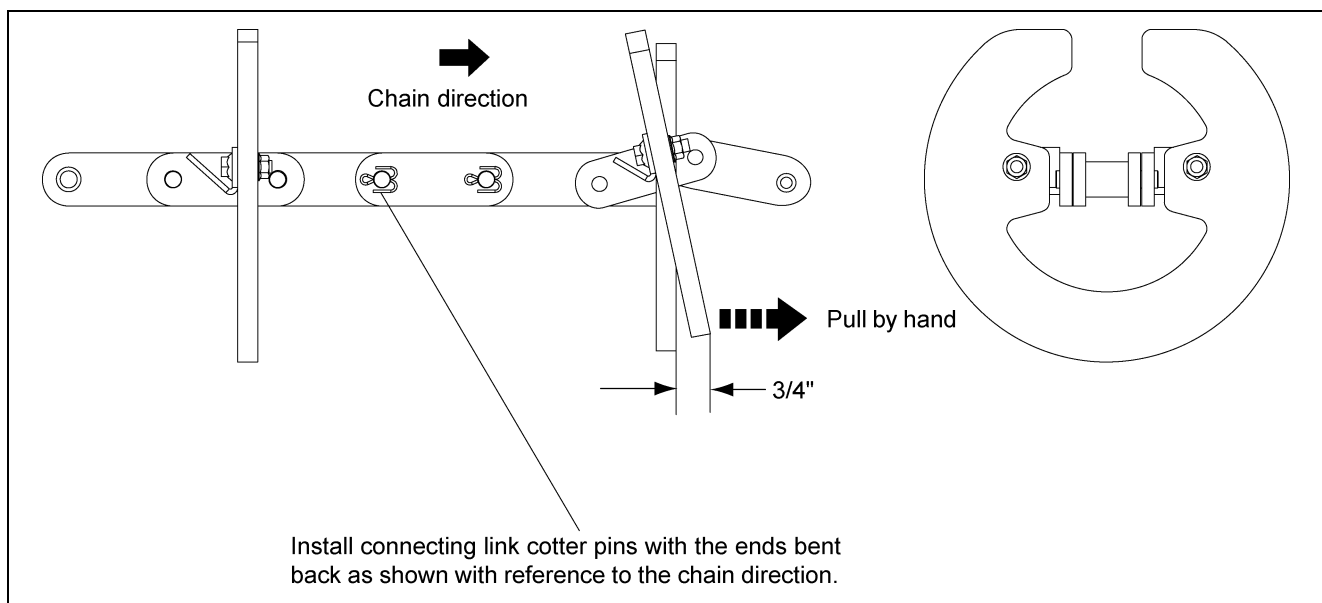

Figure 6L

6. Installation

Chain and Paddles (Continued)

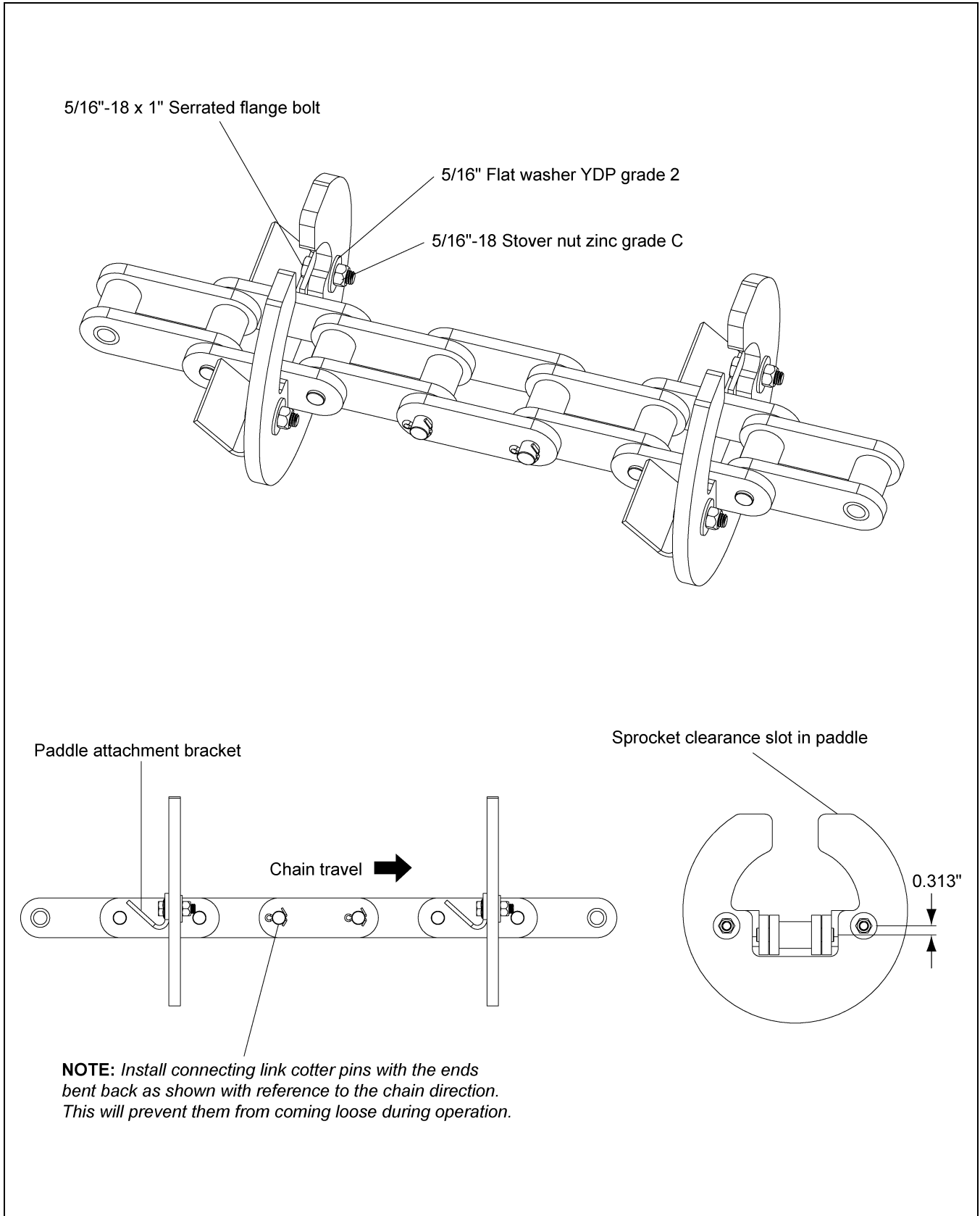

Figure 6M Chain and Paddles

Inspection Corner

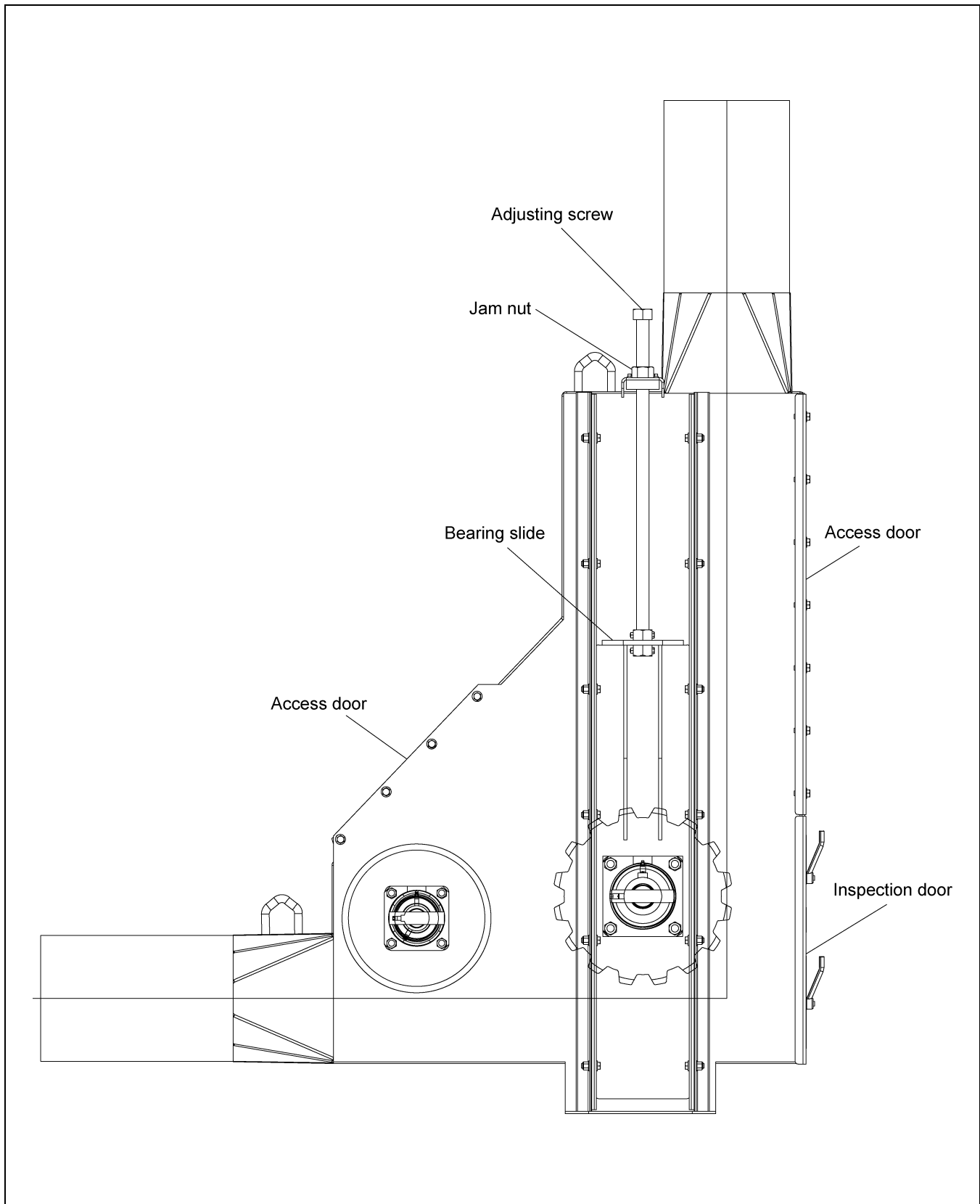

Figure 6N

6. Installation

Ground Control Kit for Discharge Gates

Determine the best location for each ground control kit. Note that each kit comes with 100' of cable, which should be adequate for individual bin installations.

The cable idler pulley bracket is usually mounted at the top of the bin wall, just under the roof eave, in line with the control wheel on the discharge gate. The ground control wheel-mounting bracket should be mounted to the bin wall directly under the idler pulley bracket at a convenient operating height. It is important to keep the cable in line with the control wheels on both the discharge gate and at the ground to avoid having the cable “walk off” either wheel.

The ground control wheel can be mounted to the same bin as the discharge gate, or to an adjacent bin (See Figure 6O and Figure 6P.)

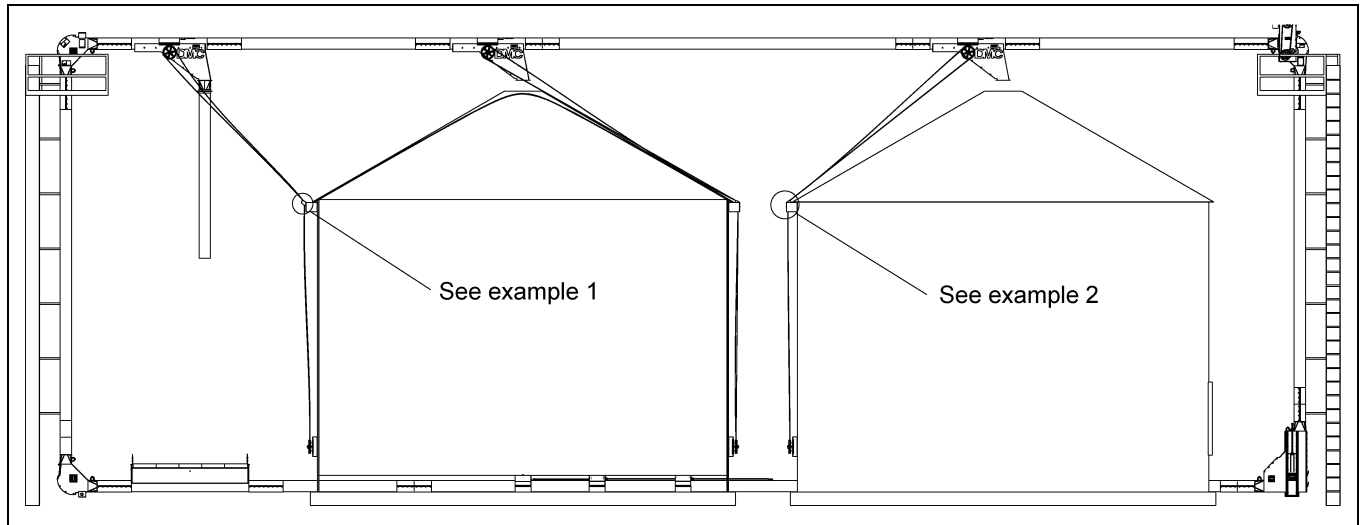

Figure 6O

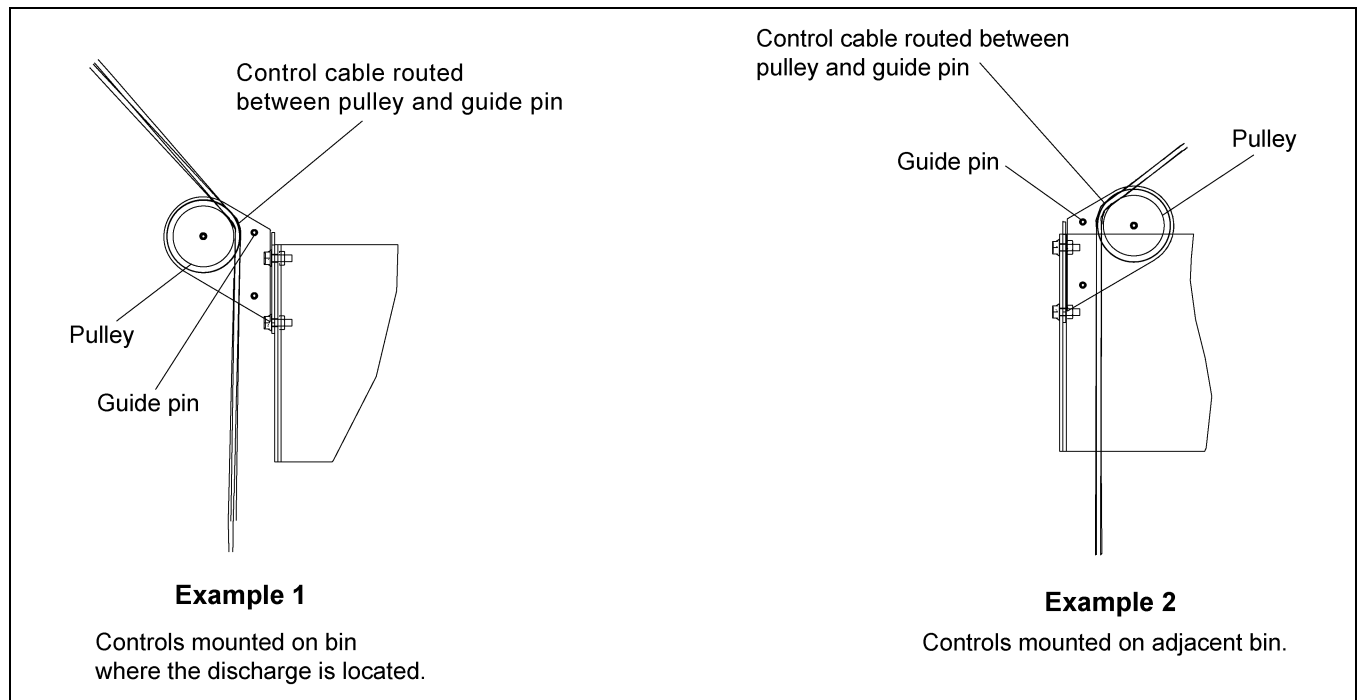

Figure 6P

Ground Control Kit for Discharge Gates (Continued)

Each control system should be marked to identify which discharge gate is being controlled.

Each control system should be marked after installation to clearly identify whether the discharge gate is open or closed.

Set screws in the ground control wheel can be used to lock the wheel in position to prevent accidental opening or closing of the discharge gate.

Assemble the idler pulleys to the mounting bracket on the inside surface if the cable is going to a discharge gate on the same bin. Assemble them on the outside if the cable is going to an adjacent bin. Attach the idler pulley bracket to the bin wall just under the eave to ensure that the cable will clear the bin roof.

Attach the ground control wheel bracket to the bin wall directly below the idler bracket. Assemble the wheel-mounting bracket loosely to the wall bracket and slide it up as far as possible. Assemble the control wheel to the shaft and secure with cotter pins. [\(See Page 35.\)](#)

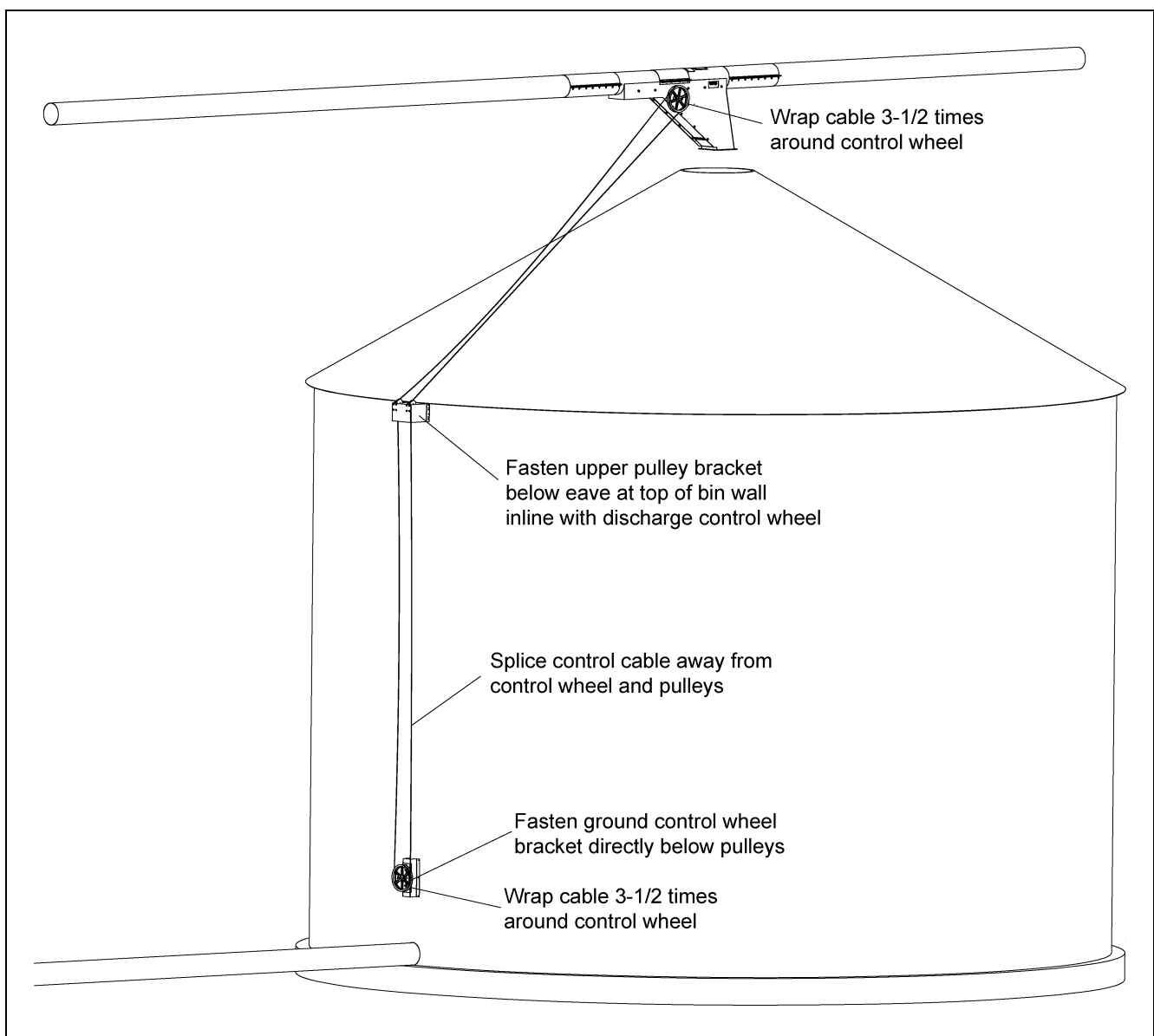

Figure 6Q

6. Installation

Ground Control Kit for Discharge Gates (Continued)

Make sure that the discharge gate is half open **and wrap the cable 3-1/2 times around the discharge gate control wheel. Note that turning the wheel clockwise will close the gate.**

Secure the cable to the wheel with the cable clamp by attaching it to the approximate middle of the 3-1/2 wraps of cable. This will ensure that the gate will fully open and close without restriction from the cable clamped to the wheel.

Make sure that the discharge gate is still half open.

Route the cable back through the right idler pulley and down to the ground control wheel.

At the ground control wheel, turn the wheel until the cable clamp is up and wrap the cable 3-1/2 times around it.

Secure the cable clamp to the middle wrap.

Splice the ends of the cable with a cable clamp. With the discharge gate half open, the splice should be at least 5' away from the pulleys and control wheels.

Slide the ground wheel bracket down to take up any slack in the cable and tighten in place.

Check the installation by turning the ground wheel clockwise to fully close the discharge gate and counterclockwise to fully open the gate without any restrictions from the cable splice or the clamps on the control wheels.

If the rotation is wrong, then reverse the direction of the 3-1/2 wraps on the ground control wheel.

Ground Control Kit for Discharge Gates (Continued)

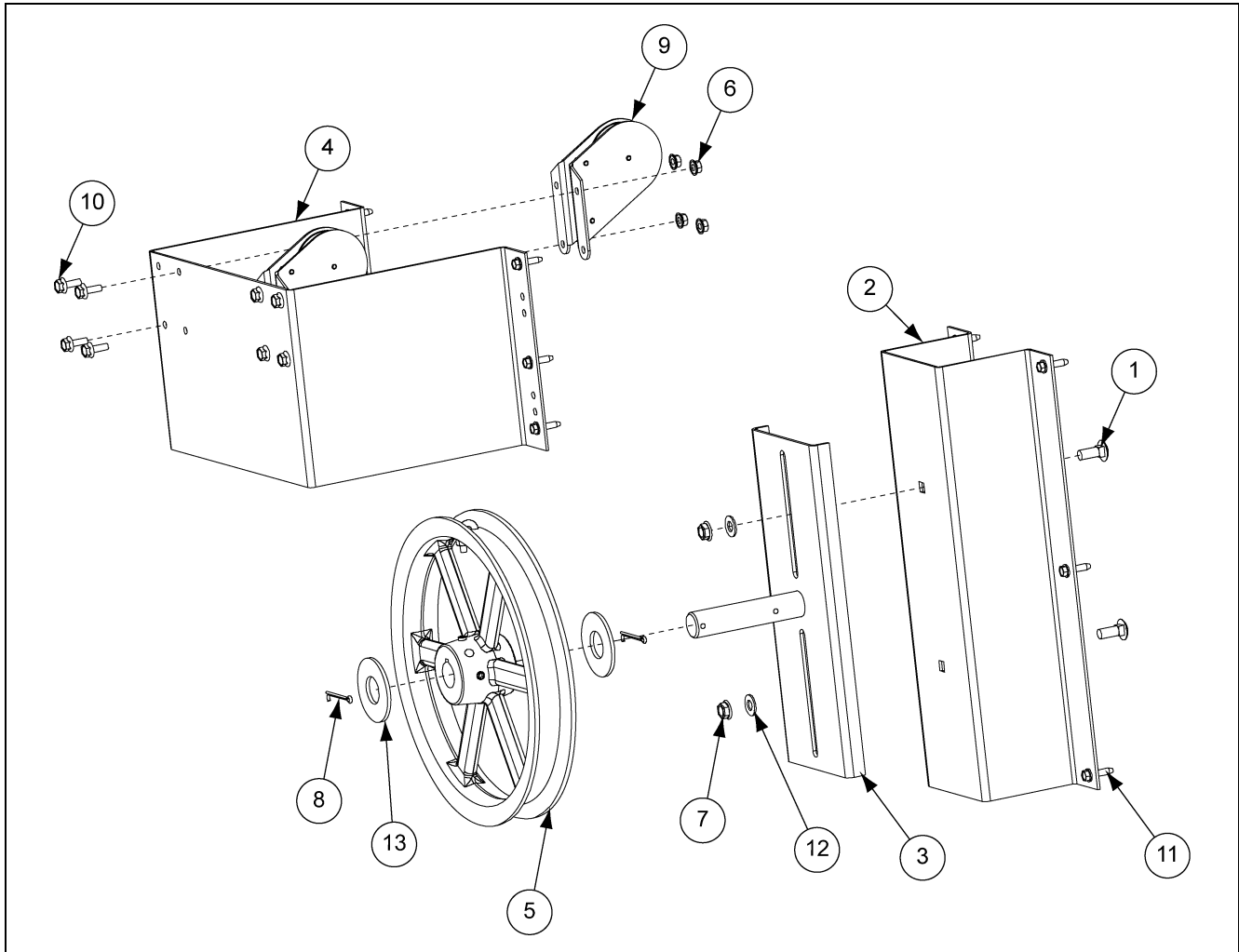

Figure 6R Ground Control Kit Parts

Ground Control Kit Parts List

Ref #	Part #	Description	Qty
1		Bolt-Car, Standard Third-Grade 2 3/8"-16 UNC x 0.75, Plated	2
2	8101157	Bracket-Bin Wall Mount Ground Control Kit	1
3	8101158	Bracket-Control Wheel, Weldment Zinc Plated 8101159	1
4	8101156	Bracket-Pulley Mount, Ground Control Kit	1
5	8101153	Control Wheel - w/ Clamp 90° Discharge w/ Gate	1
6		Lock Nut, Flange, 1/4"-20 UNC (Whiz Lock) Plated	8
7		Lock Nut, Flange, 3/8"-16 UNC (Whiz Lock) Plated	2
8		Cotter Pin, Standard 3/16" x 1-3/4" Long	2
9		Pulley-Hot House, (Nolin Milling No #)	2
10		Screw-MF Flange Whiz Lock 1/4"-20 UNC x 3/4", Plated	8
11		Screw - s/ Drill, WH Hex Head 1/4"-14 x 1", (Tek 3) Plated	12
12		Flat Washer, Standard 3/8", Plated	2
13		Flat Washer, Standard 1", Plated	2

6. Installation

Inlet Dump Hopper Assembly

The dump hopper will include a length of tubular conveyor from 6' to 11' depending on the length of dump hopper selected. It will also include a top safety screen or drive over grating. There is a grain flow control inside the hopper that is adjustable using chains mounted at each end. A dump hopper is to receive grain into the Chain Loop System and should be located at a point along the bottom conveyor portion. Usually dump hoppers are located near the standard corner where the chain and paddles turn to carry grain up.

For drive over systems, the grate must be supported by a concrete structure. (See Figure 6S.)

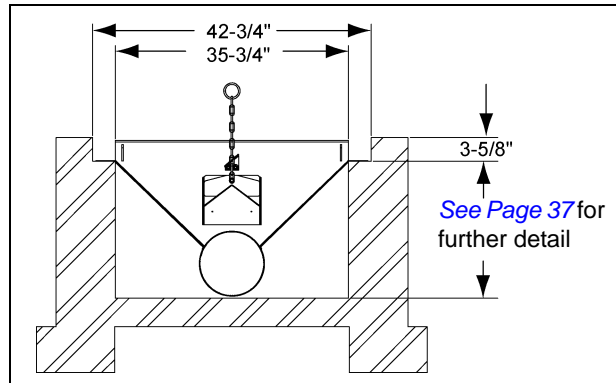

Figure 6S

A hopper with top safety screen may be used in non-drive over situations. The top safety screen will not support vehicles. Make sure either the top safety screen or drive-over grating is in place on the hopper.

Fasten the inlet dump hopper assembly in place within the tubular conveyor with connecting bands.

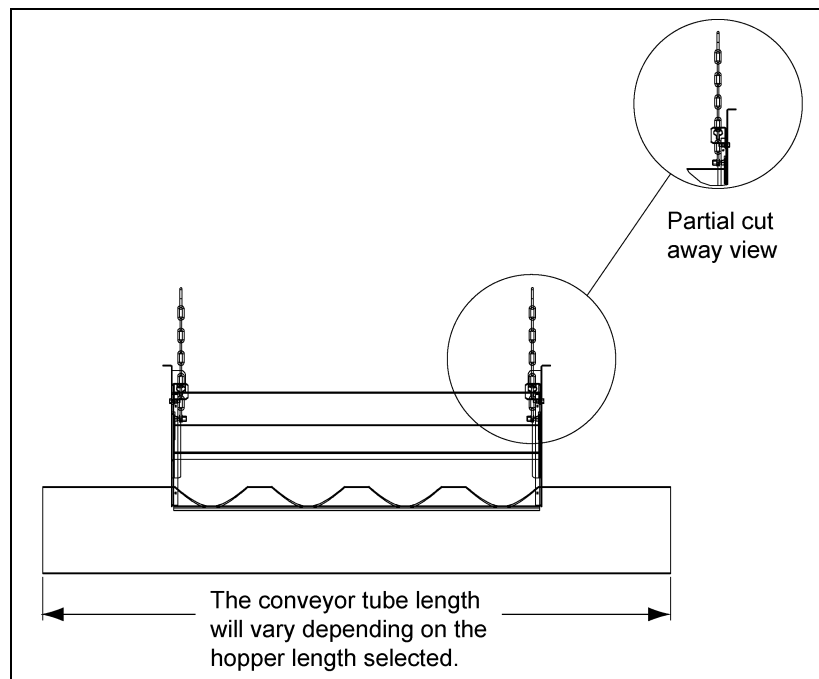

Figure 6T

NOTE: When the system is not in use, it is a good practice to cover the hopper with a rubber mat to help keep water, animals and debris out.

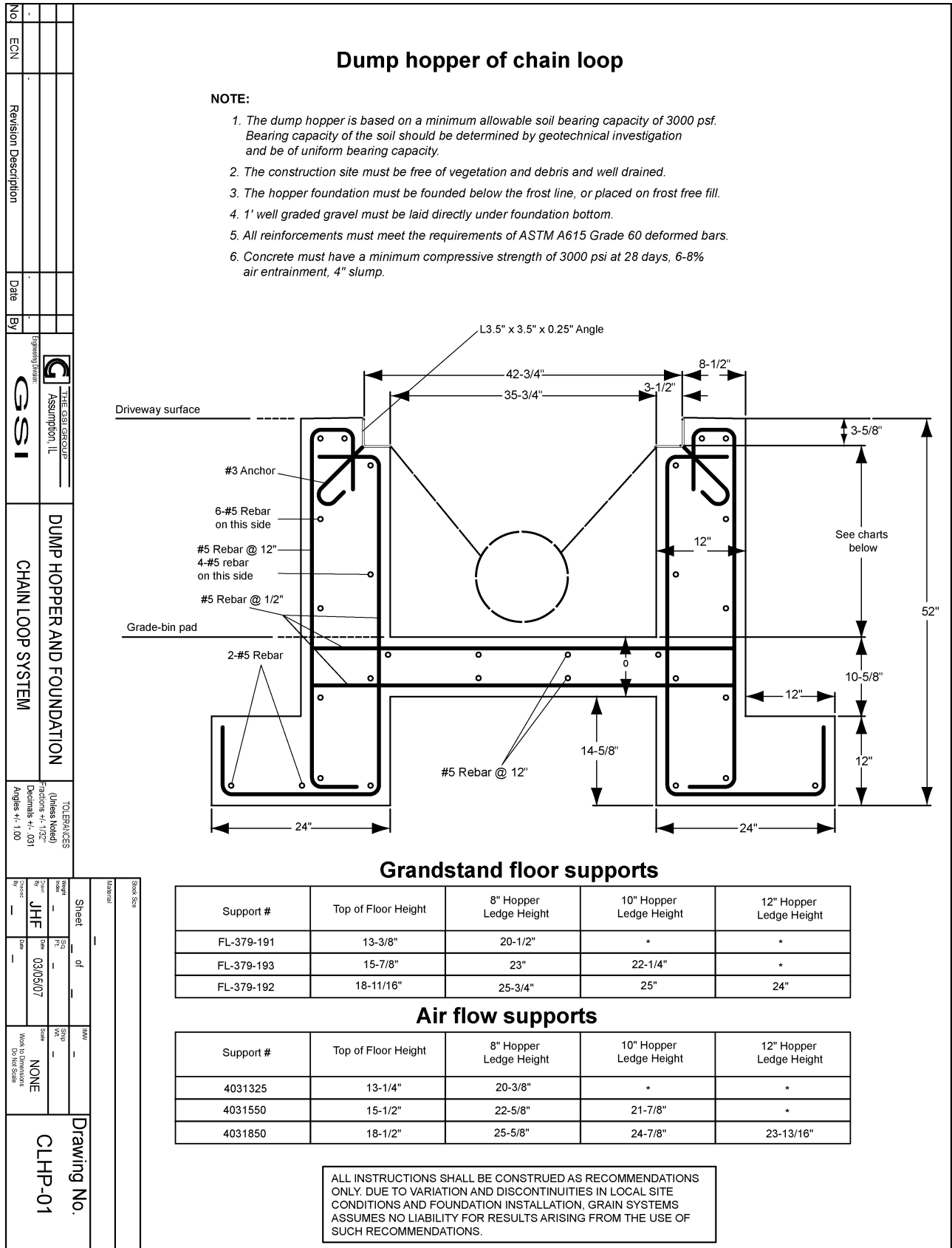

Figure 6U

7. Troubleshooting

1. Chain is slipping on the drive sprocket

- a. Check the chain tension and tighten at the inspection corner if necessary.
- b. Check for obstructions in the system. The paddles may be catching at joints in the tubing.
- c. Check to make sure that the sprockets are centered in the corner housings.
- d. Avoid starting the system under load. Let the system run until empty before shutting down. If shut down does occur while the system is loaded, remove as much grain as possible and turn the corner sprockets by hand with a pipe wrench to loosen the chain before turning the power back ON.

2. Grain recycling back to the fill point

- a. Check to make sure that the discharge gate is open.
- b. Check and clean out the slide gate in the discharge gate.
- c. Chain speed may be too fast. The drive corner shaft speed should be 94 RPM.

3. Drive belts are slipping

- a. Check the drive motor amperage and make sure that the motor is not overloaded.
- b. Tighten belts if slippage occurs when the drive motor is not fully loaded.

4. System is not delivering full capacity

- a. Make sure that grain is not over running the discharge gate and returning to the fill-point.
- b. Chain speed may be too slow. The drive corner shaft speed should be 94 RPM.
- c. High moisture grain will move at a lower capacity than dry grain.
- d. Check for obstructions in the inlet hopper.
- e. Check to make sure that the chain has not been installed with a twist. ([See Page 29.](#))

5. Paddles breaking

- a. Check to make sure that the sprockets are centered in the corner housings.
- b. Avoid starting the system under load. Let the system run until empty before shutting down. If shut down does occur while the system is loaded, remove as much grain as possible and turn the corner sprockets by hand with a pipe wrench to loosen the chain before turning the power back ON.
- c. Check to make sure that the paddles are fastened securely to the chain brackets.
- d. Let the system “break-in” and the tubing become polished before loading to full capacity.
- e. If you hear paddles “clicking” at a joint, check for gaps in the tubing. This will require loosening the bolts in the connecting band to be able to see the tube joint.

6. Chain failure

- a. Check to make sure that the master connecting links have been installed correctly. ([See Figure 6M on Page 30.](#))
- b. Check for obstructions in the system.
- c. Avoid starting the system under load. Let the system run until empty before shutting down.

8", 10" and 12" Component Dimensions

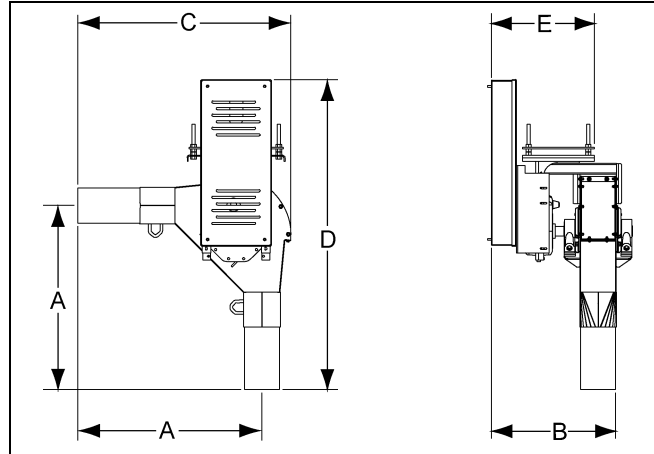

Figure 8A

Drive Corners

Horse Power	8" System	10" System	12" 10 Gauge	12" 7 Gauge
15	8081365			
20	8081363	8101526		
25-30	8081360	8101517	8120181	8120009
40		8101513	8120182	8120143
50		8101514	8120183	8120171
60			8120184	8120162

Dimension	8" System inches (mm)	10" System inches (mm)	12" 10 Gauge System inches (mm)	12" 7 Gauge System inches (mm)
"A"	42-1/16" (1069)	42-1/2" (1080)	55-11/16" (1415)	55-11/16" (1415)
"B"	29-7/16" (748)	34" (864)	33" (838)	33" (838)
"C"	48-3/4" (1239)	50-1/4" (1277)	63-5/16" (1609)	63-5/16" (1609)
"D"	70-7/8" (1801)	81-7/8" (2081)	101-15/16" (2574)	101-15/16" (2574)
"E"	33-1/8" (842)	37-9/16" (955)	45-1/2" (1156)	45-1/2" (1156)

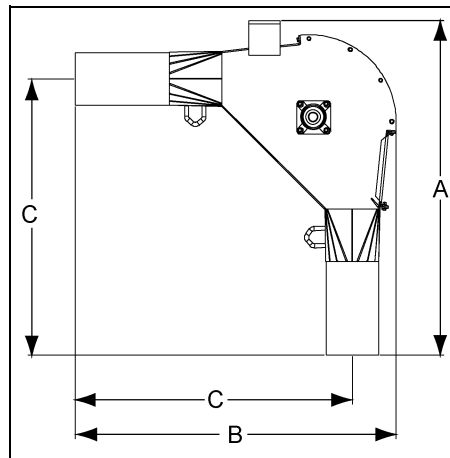

Figure 8B

Standard Corners

Dimension	8" System inches (mm)	10" System inches (mm)	12" 10 Gauge System inches (mm)	12" 7 Gauge System inches (mm)
"A"	50-7/32" (1275)	51-21/32" (1312)	65-25/32" (1670)	65-25/32" (1670)
"B"	48-3/4" (1238)	50-1/16" (1271)	63-9/32" (1607)	63-9/32" (1607)
"C"	42-1/16" (1068)	42-1/2" (1080)	55-11/16" (1415)	55-11/16" (1415)
Assembly	P.N. 8081021	P.N. 8101021	P.N. 8120176	P.N. 8120031

8. Component Dimensions

8", 10" and 12" Component Dimensions (Continued)

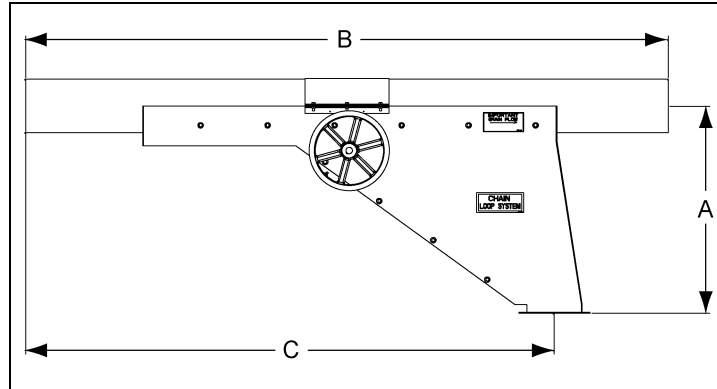

Figure 8C

Discharge Gates

Dimension	8" System inches (mm)	10" System inches (mm)	12" 10 Gauge System inches (mm)	12" 7 Gauge System inches (mm)
"A"	30-1/16" (764)	32-1/16" (814)	54-11/16" (1388)	54-11/16" (1388)
"B"	96" (2438)	96" (2438)	144" (3657)	144" (3657)
"C"	79" (2007)	79" (2007)	123-63/64" (3148)	123-63/64" (3148)
Assembly	8081206	8101206	8120090	8120194

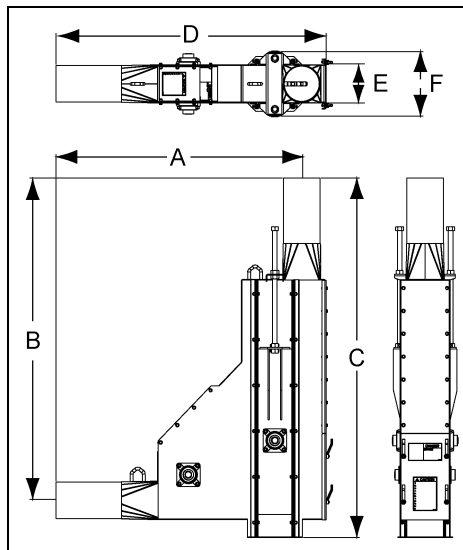

Figure 8D

Inspection Corners

Dimension	8" System inches (mm)	10" System inches (mm)	12" 10 Gauge System inches (mm)	12" 7 Gauge System inches (mm)
"A"	53-5/8" (1362)	54-5/8" (1387)	67-19/32" (1717)	67-19/32" (1717)
"B"	70-7/16" (1789)	71-1/2" (1816)	86-3/32" (2187)	86-3/32" (2187)
"C"	78-19/32" (1996)	80-21/32" (2049)	96-3/16" (2443)	96-3/16" (2443)
"D"	58-15/16" (1497)	61-1/8" (1553)	75-7/32" (1911)	75-7/32" (1911)
"E"	8-3/8" (213)	10-3/8" (264)	12-3/16" (309)	12-3/16" (309)
"F"	13-7/8" (1492)	15-7/8" (403)	25-5/16" (643)	25-5/16" (643)
Assembly	8081048	8101048	8120177	8120051

8", 10" and 12" Bin Well and Dump Hopper Dimensions

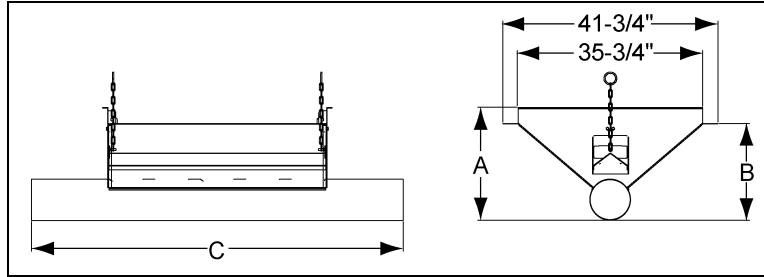

Figure 8E

Inlet Hopper Part Numbers and Dimensions

Assembly Description (Hopper Width)	Part #				Dimension "C" inches (mm)
	8" System	10" System	12" 10 Gauge System	12" 7 Gauge System	
42-1/2" w/ Drive-over Grates	8089025	8109035	8129021	8129024	72" (1829)
42-1/2" Hopper Assembly Only	8081106	8101106	8120185	8120121	72" (1829)
62-1/2" w/ Drive-over Grates	8089027	8109027			92" (2337)
62-1/2" Hopper Assembly Only	8081107	8101107			92" (2337)
102-1/2" w/ Drive-over Grates	8089029	8109039	8129022	8129025	132" (3353)
102-1/2" Hopper Assembly Only	8081108	8101108	8120186	8120127	132" (3353)
122-1/2" w/ Drive-over Grates			8129023	8129026	152" (3861)
122-1/2" Hopper Assembly Only			8120187	8120134	152" (3861)
125" w/ Drive-over Grates	8089031	8101166L			155" (3937)
125" Hopper Assembly Only	8081166	8101166			155" (3937)
144-1/2" w/ Drive-over Grates	8089033	8109043			168" (4267)
144-1/2" Hopper Assembly Only	8081109	8101109			168" (4267)
Dimension	8" System inches (mm)	10" System inches (mm)	12" 10 Gauge System inches (mm)	12" 7 Gauge System inches (mm)	
"A" (Top of Drive-over Grate)	22-1/2" (572)	24-3/8" (619)	24-13/32" (620)	24-13/32" (620)	
"B" (Top of Hopper Flange)	18-3/4" (476)	20-3/4" (527)	21-3/8" (543)	21-3/8" (543)	

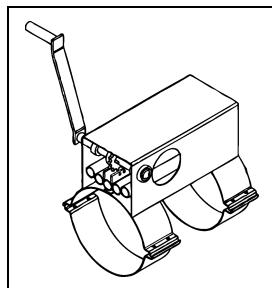

Figure 8F

Rack and Pinion Controls

Dimension	8" System inches (mm)	10" System inches (mm)	12" System inches (mm)
Length	15-1/2" (394)	15-1/2" (619)	15-1/2" (619)
Top Width	7-1/4" (476)	7-1/4" (476)	7-1/4" (476)
Height* *(ctr. of tube to top)	9-1/2" (241)	10-1/2" (267)	11-1/2" (292)
Assembly	GK1768	GK1772	GK1787

8. Component Dimensions

8", 10" and 12" Bin Well and Dump Hopper Dimensions (Continued)

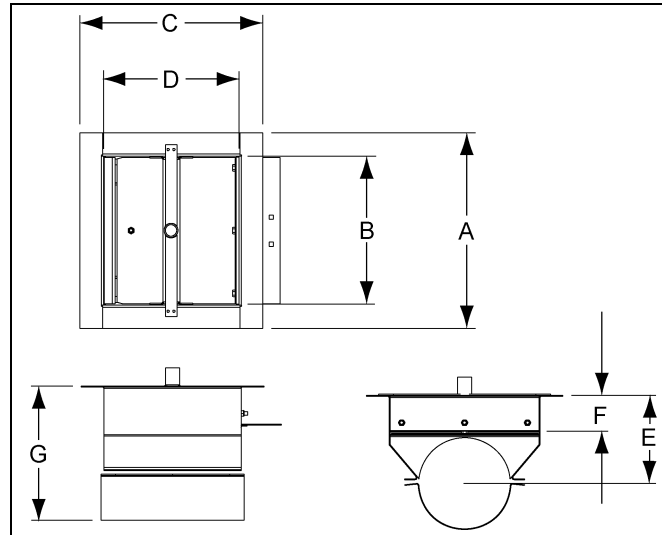

Figure 8G
Center Wells

Dimension	8" System		10" System	
	w/o Rollers inches (mm)	with Roller inches (mm)	w/o Rollers inches (mm)	with Roller inches (mm)
"A"	17-1/8" (435)	17-1/8" (435)	17-1/8" (435)	17-9/32" (439)
"B"	13" (330)	13" (330)	13" (330)	13" (330)
"C"	16" (406)	16" (406)	18" (457)	18" (457)
"D"	12" (305)	12" (305)	13-3/4" (349)	13-3/4" (349)
"E"	7-3/4" (197)	7-3/4" (197)	9-1/2" (241)	9-1/2" (241)
"F"	3-1/8" (79)	3-1/8" (79)	3-3/8" (86)	3-3/8" (86)
"G"	11-3/4" (298)	11-3/4" (298)	14-1/2" (368)	14-1/2" (368)
Assembly	GK2785	8081192	GK1943	8101192

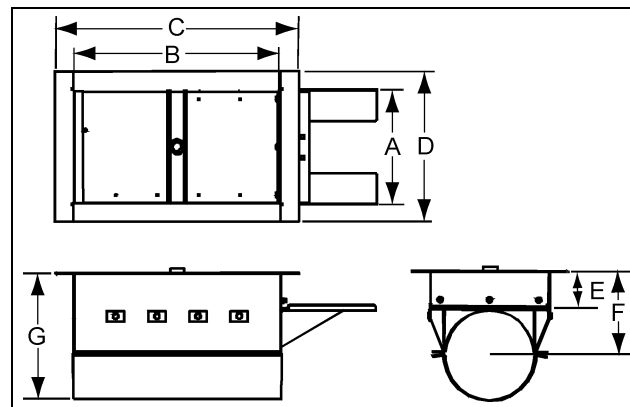

Figure 8H
Large Center Wells

Dimension	8" System inches with Roller inches (mm)	10" System inches with Roller inches (mm)	12" System inches with Roller inches (mm)
"A"	13" (330)	13" (330)	13" (330)
"B"	21-27/32" (555)	23-3/4" (603)	23-3/4" (603)
"C"	25-31/32" (659)	28" (711)	28" (711)
"D"	17-5/32" (436)	17-9/32" (439)	17-9/32" (439)
"E"	3-9/32" (83)	4-1/16" (103)	4-1/16" (103)
"F"	7-23/32" (196)	9-13/32" (239)	10-3/8" (263)
"G"	11-25/32" (299)	14-1/2" (368)	16-1/2" (419)
Assembly	8081238	8101254	8120101

8", 10" and 12" Bin Well and Dump Hopper Dimensions (Continued)

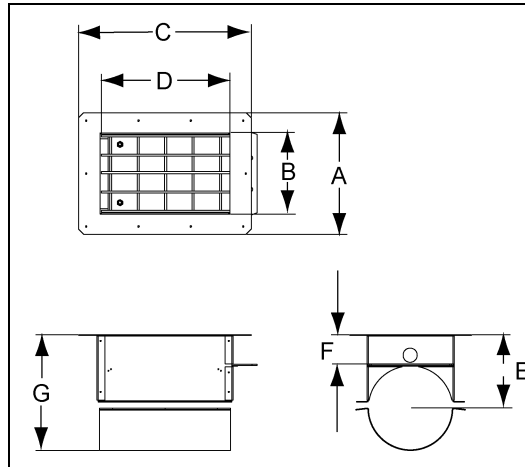

Figure 8I

Intermediate Wells

Dimension	8" System		10" System			*12" System with Rollers inches (mm)
	w/o Rollers inches (mm)	with Rollers inches (mm)	w/o Rollers inches (mm)	with Rollers inches (mm)	w/o Slide Gate inches (mm)	
"A"	11-5/8" (295)	13-1/8" (333)	17-1/8" (435)	17-1/8" (435)	17-1/8" (435)	22-1/4" (565)
"B"	7-1/2" (191)	7-5/16" (186)	13" (330)	13" (330)	13" (330)	14-1/4" (362)
"C"	16-1/2" (419)	19-1/4" (489)	18" (457)	18" (457)	22" (559)	34-1/2" (876)
"D"	13-1/2" (343)	13-1/2" (343)	13-7/8" (352)	13-7/8" (352)	17-7/8" (454)	13-1/8" (333)
"E"	7" (178)	7-5/8" (194)	9-1/2" (241)	9-1/2" (241)	9-1/2" (241)	10" (254)
"F"	2-3/4" (70)	1-15/16" (49)	2-1/8" (54)	2-1/8" (54)		2-1/8" (54)
"G"	11" (279)	11-5/8" (295)	14-1/2" (368)	14-1/2" (368)	14-1/2" (368)	16" (406)
Assembly	GK2779	GK5182	GK1942	8101193	8101194	*GK2927

* 12" Commercial intermediate well drawing below. (See Figure 8J.)

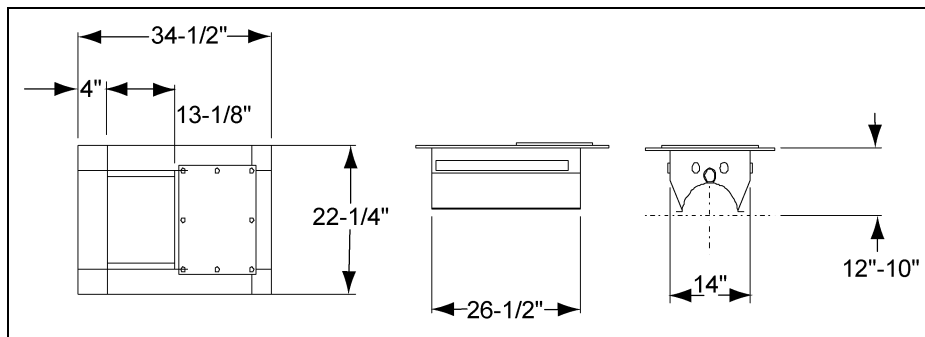

Figure 8J

12" Well (Intermediate)

Product #	Description	Weight
GCBW1250	12" Intermediate	54 lbs.

9. Parts List

1. 8" and 10" Chain and Paddles - [\(See Page 46.\)](#)
2. 12" Chain and Paddles (8120141) - [\(See Page 47.\)](#)
3. 8" and 10" Discharge Gate - [\(See Page 48.\)](#)
4. 12" - (7 Gauge) Discharge Gate (8120194) - [\(See Page 49.\)](#)
5. 12" - (10 Gauge) Discharge Gate (8120090) - [\(See Page 50-51.\)](#)
6. Chain Loop Drive Components - [\(See Page 52-54.\)](#)
7. 8" (15 HP) Drive Components (8081365) - [\(See Page 55.\)](#)
8. 8" (20 HP) Drive Components (8081363) - [\(See Page 56.\)](#)
9. 8" (15 HP-20 HP) Drive Components (8081362) - [\(See Page 57.\)](#)
10. 10" (20 HP) Drive Components (8101526) - [\(See Page 58.\)](#)
11. 10" (15 HP-20 HP) Drive Components (8101525) - [\(See Page 59.\)](#)
12. 8" (25 HP-30 HP) Drive Components (8081360) - [\(See Page 60.\)](#)
13. 8" (25 HP-30 HP) Drive Components (8081359) - [\(See Page 61.\)](#)
14. 10" (25 HP-30 HP) Drive Components (8101517) - [\(See Page 62.\)](#)
15. 10" (25 HP-30 HP) Drive Components (8101516) - [\(See Page 63.\)](#)
16. 10" (40 HP) Drive Components (8101513) - [\(See Page 64.\)](#)
17. 10" (50 HP) Drive Components (8101514) - [\(See Page 65.\)](#)
18. 10" (40 HP-50 HP) Drive Components (8101511) - [\(See Page 66.\)](#)
19. 8" (15 HP) Drive Components (8081271) - [\(See Page 67.\)](#)
20. 8" (20 HP) Drive Components (8081285) - [\(See Page 68.\)](#)
21. 8"-10" (25 HP-30 HP) Drive Components (8081296) - [\(See Page 69.\)](#)
22. 10" (40 HP) Drive Components (8101303) - [\(See Page 70.\)](#)
23. 10" (50 HP) Drive Components (8101331) - [\(See Page 71.\)](#)

24. Belt Guard Assembly TA3 (8120217) - [\(See Page 72.\)](#)
25. Belt Guard Assembly TA4 (8120211) - [\(See Page 74.\)](#)
26. Belt Guard Assembly TA5 (8120214) - [\(See Page 75.\)](#)
27. 12" 7 Gauge (30 HP) Drive Components (8120000) - [\(See Page 76-77.\)](#)
28. 12" 7 Gauge (40 HP-50 HP) Drive Components (8120144) - [\(See Page 78-79.\)](#)
29. 12" 7 Gauge (60 HP) Drive Components (8120163) - [\(See Page 80-81.\)](#)
30. 12" 10 Gauge (30 HP) Drive Components (8120175) - [\(See Page 82-83.\)](#)
31. 12" 10 Gauge (40 HP-50 HP) Drive Components (8120179) - [\(See Page 84-85.\)](#)
32. 12" 10 Gauge (60 HP) Drive Components (8120180) - [\(See Page 86-87.\)](#)
33. 8" and 10" Inlet Dump Hoppers - [\(See Page 88.\)](#)
34. 12" (7 Gauge) 42-1/2" Inlet Dump Hoppers (8120121) - [\(See Page 89.\)](#)
35. 12" (7 Gauge) 102-1/2" Inlet Dump Hoppers (8120127) - [\(See Page 90.\)](#)
36. 12" (7 Gauge) 122-1/2" Inlet Dump Hoppers (8120134) - [\(See Page 91.\)](#)
37. 12" (10 Gauge) 42-1/2" Inlet Dump Hoppers (8120185) - [\(See Page 92.\)](#)
38. 12" (10 Gauge) 102-1/2" Inlet Dump Hoppers (8120186) - [\(See Page 94.\)](#)
39. 12" (10 Gauge) 122-1/2" Inlet Dump Hoppers (8120187) - [\(See Page 95.\)](#)
40. 8" and 10" Standard Corner - [\(See Page 96-97.\)](#)
41. 12" (7 Gauge) Standard Corner (8120031) - [\(See Page 98-99.\)](#)
42. 12" (10 Gauge) Standard Corner (8120176) - [\(See Page 100-101.\)](#)
43. 8" and 10" Inspection Corner - [\(See Page 102-103.\)](#)
44. 12" (7 Gauge) Inspection Corner (8120051) - [\(See Page 104-105.\)](#)
45. 12" (10 Gauge) Inspection Corner (8120177) - [\(See Page 106-107.\)](#)
46. Chain Loop Torque Plate Assembly - [\(See Page 108.\)](#)

9. Parts List

8" and 10" Chain and Paddles

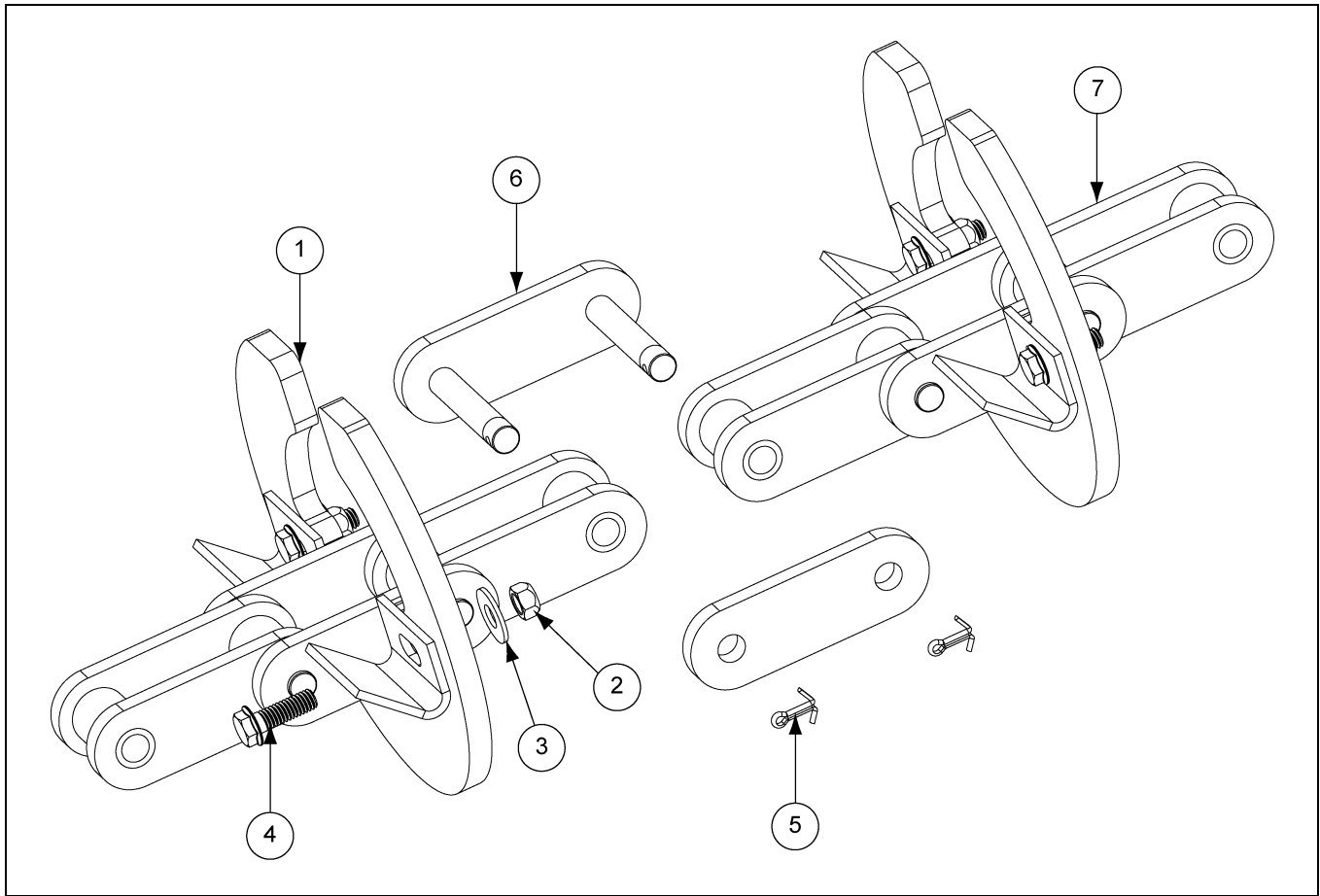

8" and 10" Chain and Paddles Parts List

Ref #	Part #	Description
1	8101145	Paddle 10", UHMW 10" Chain Loop System
1	8081145	Paddle 8", UHMW 8" Chain Loop System
2	S-8324	5/16"-18 Stover Nut Zinc Grade C
3	S-845	Flat Washer 5/16" USS SAE YDP Grade 2
4	S-7470	5/16"-18 x 1" Serrated Flange Bolt Zinc Grade 5
5	S-9159	1/8" x 3/4" Cotter Pin Zinc
6	CE-00764	Link Connecting, #81 x with Side Plate and Cotter Pin
6	CE-00766	Link Connecting, #81 x HH with Side Plate and Cotter Pin
7	8101162 - 8"	Chain Standard, 81 x with Brackets and Connecting Link
7	8101163 - 10"	Chain Heavy Duty, 81 x HH with Brackets and Connecting Link

12" Chain and Paddles (8120141)

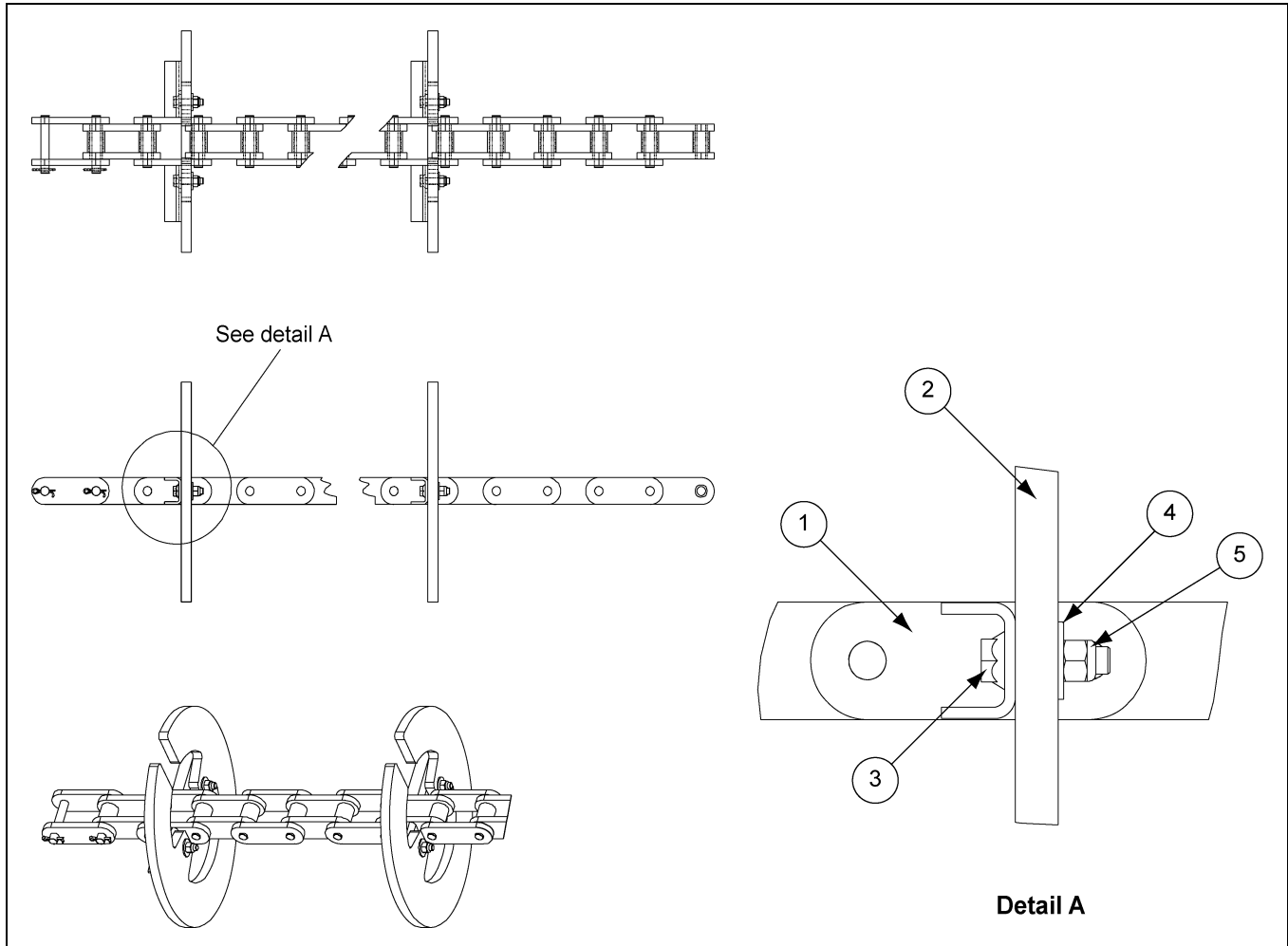

12" Chain and Paddles (8120141) Parts List

Ref #	Part #	Description	Qty
1	8120140	Chain with Bracket 12' 81 x HH with Conlk	1
2	8120139	Paddle, 12" Chain Loop UHMW	9
3	S-8135	Flange Bolt 5/16"-18 x 1-1/4" ZN Grade 5	18
4	S-845	Flat Washer 5/16" USS SAE YDP Grade 2	18
5	S-7382	Nylock Nut 5/16"-18 ZN Grade 5	18

9. Parts List

8" and 10" Discharge Gate

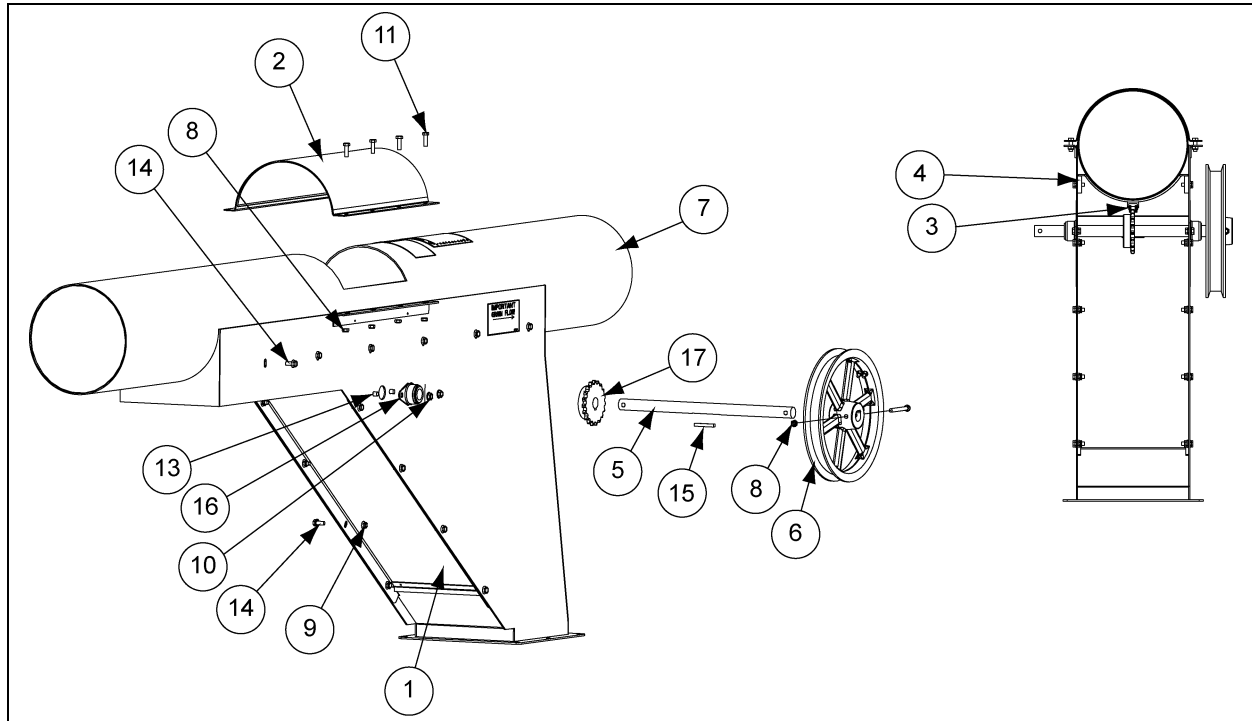

Ref #	Part #	Description	Qty
1	8081093	Access Panel-Weldment 8" 90° Discharge with Gate	1
1	8101093	Access Panel-Weldment 10" 90° Discharge with Gate	1
2	8081096	Access Door-Assembly 8" 90° Discharge with Gate	1
2	8101096	Access Door-Assembly 10" 90° Discharge with Gate	1
3	8081097	Slide Gate-Weldment 8" 90° Discharge with Gate	1
3	8101097	Slide Gate-Weldment 10" 90° Discharge with Gate	1
4	8081351	Chain Loop 8" Discharge Gate Rail	2
4	8101501	Chain Loop 10" Discharge Gate Rail	2
5	8081103	Shaft-1" O.D. x 16-1/4" Zinc Plated 8081104	1
5	8101103	Shaft-1" O.D. x 17-3/4" Zinc Plated 8101104	1
6	8101153	Control Wheel - w/ Clamp 90° Discharge w/ Gate	1
7	8081203	Discharge w/ Gate-90, 8" Zinc Plated 8081182	1
7	8101203	Discharge w/ Gate-90, 10" Zinc Plated 8101182	1
8		Lock Nut, 5/16"-18 UNC Nylon Lock, Plated Grade 2	9
9		Lock Nut, Flange, 5/16"-18 UNC (Whiz Lock) Plated	8
10		Lock Nut, Flange, 3/8"-16 UNC (Whiz Lock) Plated	4
11		Hex Bolt, Standard Third-Grade 2 5/16"-18 UNC x 1", Plated	8
12		Hex Bolt, Standard Third-Grade 2 5/16"-18 UNC x 3", Plated	1
13		Screw-Flange Whiz Lock 3/8"-16 UNC x 1/2", Plated	4
14		Screw-Flange Whiz Lock 5/16"-18 UNC x 3/4", Plated	20
15		Key-Square 1/4" x 2"	1
16	PT0134	Bearing-w/ Housing, 1" Bronze Insert, 2 Hole	2
17	PT1088	Sprocket-(Hub Type) 19 Tooth, 1" I.D., #50	1

12" - (7 Gauge) Discharge Gate (8120194)

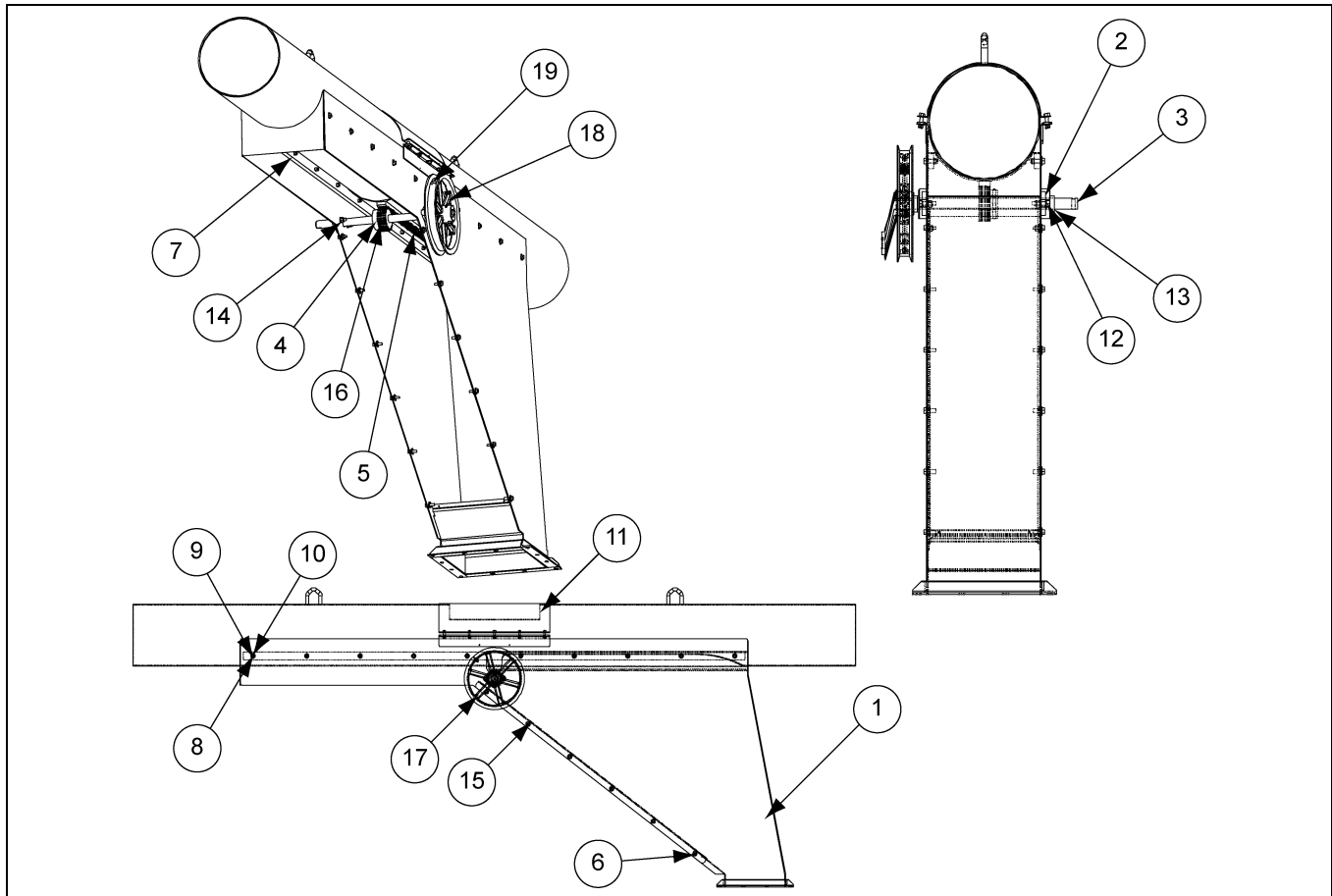

12" - (7 Gauge) Discharge Gate (8120194) Parts List

Ref #	Part #	Description	Qty
1	8120195	Discharge Gate Weld 7 Gauge	1
2	MHC01377	Bearing, Light Duty 1-1/8"	2
3	8120091	Shaft - Discharge Gate	1
4	MHC00999	Gear, Spur 8 DP 26T 1-1/8" Bore	1
5	8120088	Slide Gate Weld - Discharge Gate	1
6	8120086	Bottom Cover Weldment	1
7	8120093	UHMW Slide Bar - Discharge Gate	2
8	S-845	Flat Washer 5/16" USS SAE YDP Grade 2	64
9	S-7721	Bolt, HHCS 5/16"-18 x 1-1/4" ZN Grade 2	30
10	S-7382	Nylock Nut 5/16"-18 ZN Grade 5	43
11	8120169	12" x 22" Half Band	1
12	S-7409	Flat Washer 3/8" SAE ZN Grade 2	8
13	S-7515	Bolt, HHCS 3/8"-16 x 1-1/2" Grade 5	4
14	S-7383	Nylock Nut 3/8"-16 ZN Grade 5	4
15	S-1196	Bolt, HHCS 5/16"-18 x 1" ZN Grade 5	12
16	3FH0887	Spring Pin 1/4" x 3" Plated	1
17	8120089	Control Wheel - Discharge Gate	1
18	S-7601	Bolt, HHCS 5/16"-18 x 3" ZN Grade 2	1
19	S-8762	Clamp, 3/16" Cable Zinc Plated	1

12" - (10 Gauge) Discharge Gate (8120090)

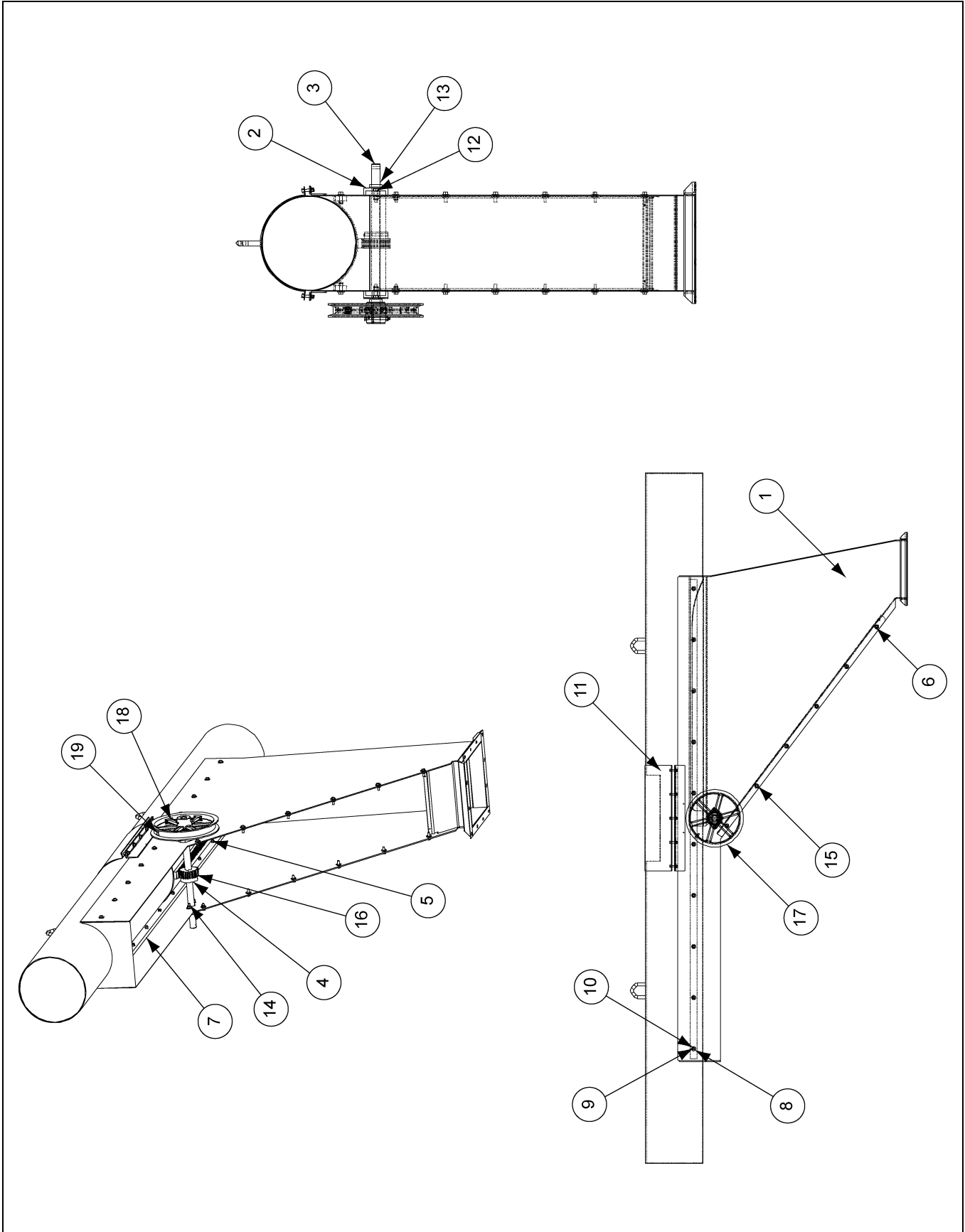

12" - (10 Gauge) Discharge Gate (8120090) Parts List

Ref #	Part #	Description	Qty
1	8120080	Discharge Gate Weld 10 Gauge	1
2	MHC01377	Bearing, Light Duty 1-1/8" Bore	2
3	8120091	Shaft - Discharge Gate	1
4	MHC00999	Gear, Spur 8 DP 26T 1-1/8" Bore	1
5	8120088	Slide Gate Weld - Discharge Gate	1
6	8120086	Bottom Cover Weldment	1
7	8120093	UHMW Slide Bar - Discharge Gate	2
8	S-845	Flat Washer 5/16" USS SAE YDP Grade 2	64
9	S-7721	Bolt, HHCS 5/16"-18 x 1-1/4" ZN Grade 2	30
10	S-7382	Nylock Nut 5/16"-18 ZN Grade 5	43
11	8120169	12" x 22" Half Band	1
12	S-7409	Flat Washer 3/8" SAE ZN Grade 2	8
13	S-7515	Bolt, HHCS 3/8"-16 x 1-1/2" Grade 5	4
14	S-7383	Nylock Nut 3/8"-16 ZN Grade 5	4
15	S-1196	Bolt, HHCS 5/16"-18 x 1" ZN Grade 5	12
16	3FH0887	Spring Pin 1/4" x 3" Plated	1
17	8120089	Control Wheel - Discharge Gate	1
18	S-7601	Bolt, HHCS 5/16"-18 x 3" ZN Grade 2	1
19	S-8762	Clamp, 3/16" Cable Zinc Plated	1

Chain Loop Drive Components

50 Hz - International Chain Loop Motors - 50 Hz

Hz	Part #	Size	Voltage	Shaft Diameter	(Lbs)	(Kgs)
50	1500-3-50	15 HP	220/380/440 3 PH	1-5/8"	264.0	119.7
50	2000-3-50	20 HP	220/380/440 3 PH	1-5/8"	277.0	125.6
50	2500-3-50	25 HP	220/380/440 3 PH	1-7/8"	480.0	217.7
50	3000-3-50	30 HP	220/380/440 3 PH	1-7/8"	380.0	172.4
50	4000-3-50	40 HP	220/380/440 3 PH	2-1/8"	571.0	259.0

8" Motor Pulleys, Bushings and Drive Belts - 50 Hz

HP	Part	Part #	Description	Qty	(Lbs)	(Kg)
15 HP	Motor Pulley	PT0703	4 Grade B6.0 SD	1	11.73	5.3
	Motor Pulley Bushing	GC06516	SD x 1-5/8" Bore	1	1.6	0.7
	Reducer Pulley	GC09690	4 Grade B6.2 SD	1	25	11.3
	Reducer Bushing	CE-00614	SD x 1-3/8" Bore	1	3.8	1.7
	Drive Belts	020-1035-3	BX59	3	0.9	0.4
20 HP	Motor Pulley	KD-PDS0028	2 Grade 5V 9.0 SK	1	23	10.4
	Motor Pulley Bushing	GC03810	SK x 1-5/8" Bore	1	5	2.3
	Reducer Pulley	KD-PDS0018	2 Grade 5V 9.25 SK	1	38	17.2
	Reducer Bushing	PT0778	SK x 1-3/8" Bore	1	9	4.1
	Drive Belts	KD-PDV0017	5VX710	4	1.1	0.5
25-30 HP	Motor Pulley	MHC01668	3 Grade 5V 9.0 SF	1	36	16.3
	Motor Pulley Bushing	MHC01162	SF x 1-7/8" Bore	1	9	4.1
	Reducer Pulley	MHC01160	3 Grade 5V 9.25 SF	1	44	19.9
	Reducer Bushing	GC07551	SF x 1-7/16" Bore	1	9	4.1
	Drive Belts	MHC00604	5VX800	3	1.1	0.5

10" Motor Pulleys, Bushings and Drive Belts - 50 Hz

HP	Part	Part #	Description	Qty	(Lbs)	(Kg)
20 HP	Motor Pulley	KD-PDS0028	2 Grade 5V 9.0 SK	1	23	10.4
	Motor Pulley Bushing	GC03810	SK x 1-5/8" Bore	1	5	2.3
	Reducer Pulley	KD-PDS0018	2 Grade 5V 9.25 SK	1	38	17.2
	Reducer Bushing	PT0778	SK x 1-3/8"	1	9	4.1
	Drive Belts	KD-PDV0017	5VX710	4	1.1	0.5
25-30 HP	Motor Pulley	MHC01668	3 Grade 5V 9.0 SF	1	36	16.3
	Motor Pulley Bushing	MHC01162	SF x 1-7/8" Bore	1	9	4.1
	Reducer Pulley	MHC01160	3 Grade 5V 9.25 SF	1	44	19.9
	Reducer Bushing	GC07551	SF x 1-7/16" Bore	1	9	4.1
	Drive Belts	MHC00604	5VX800	3	1.1	0.5
40 HP	Motor Pulley	MHC01717	4 Grade 5V 8.5 E	1	36	16.3
	Motor Pulley Bushing	MHC01540	E x 2-1/8" Bore	1	9	4.1
	Reducer Pulley	KD-PDS0016	4 Grade 5V 9.0 E	1	44	19.9
	Reducer Bushing	MHC01537	E x 1-5/8" Bore	1	9	4.1
	Drive Belts	MHC00604	5VX800	3	1.2	0.5
50 HP	Motor Pulley	KD-PDS0021	4 Grade 5V 10.3 E	1	36	16.3
	Motor Pulley Bushing	MHC01540	E x 2-1/8" Bore	1	9	4.1
	Reducer Pulley	KD-PDS0029	4 Grade 5V 10.9 E	1	44	19.9
	Reducer Bushing	MHC01537	E x 1-5/8" Bore	1	9	4.1
	Drive Belts	CE-00562	5VX900	4	1.2	0.5

Chain Loop Drive Components (Continued)

USA and Countries with 60 Hz Power Chain Loop Motors - 60 Hz

Hz	Part #	Size	Voltage	Shaft Diameter	(Lbs)	(Kgs)
60	3EL5069	15 HP	230, 1 PH	1-5/8"	314.0	142.4
60	MTR-0022	15 HP	230/460 3 PH	1-5/8"	234.0	106.1
60	MTR-0025	20 HP	230/460 3 PH	1-5/8"	264.0	119.7
60	MTR-0054	25 HP	230/460 3 PH	1-7/8"	396.0	179.6
60	MTR-0056	30 HP	230/460 3 PH	1-7/8"	433.0	196.4
60	MTR-0063	40 HP	230/460 3 PH	2-1/8"	514.0	233.1
60	MTR-0067	50 HP	230/460 3 PH	2-1/8"	579.0	263.0
60	MTR-0069	60 HP	230/460 3 PH	2-3/8"	747.0	339.0

8" Motor Pulleys, Bushings and Drive Belts - 60 Hz

HP	Part	Part #	Description	Qty	(Lbs)	(Kg)
15 HP	Motor Pulley	CE-00582	3 Grade B6.4 SD	1	11.73	5.3
	Motor Pulley Bushing	GC06516	SD x 1-5/8" Bore	1	1.6	0.7
	Reducer Pulley	GC07874	3 Grade B8.0 SK	1	25	11.3
	Reducer Bushing	PT0778	SK x 1-3/8" Bore	1	3.8	1.7
	Drive Belts	MHC00823	BX61	3	0.9	0.4
20 HP	Motor Pulley	3311A1	4 Grade B6.4 SD	1	23	10.4
	Motor Pulley Bushing	GC06516	SD x 1-5/8" Bore	1	5	2.3
	Reducer Pulley	GC06676	4 Grade B8.0 SK	1	38	17.2
	Reducer Bushing	PT0778	SK x 1-3/8"	1	9	4.1
	Drive Belts	MHC00823	BX61	4	1.1	0.5
25-30 HP	Motor Pulley	MHC01566	3 Grade B11.0 SK	1	36	16.3
	Motor Pulley Bushing	CE-00617	SK x 1-7/8" Bore	1	9	4.1
	Reducer Pulley	MHC01567	3 Grade B13.6 SK	1	44	19.9
	Reducer Bushing	GC06687	SK x 1-7/16" Bore	1	9	4.1
	Drive Belts	D02-0067	BX85	3	1.1	0.5

Chain Loop Drive Components (Continued)

10" Motor Pulleys, Bushings and Drive Belts - 60 Hz

HP	Part	Part #	Description	Qty	(Lbs)	(Kg)
20 HP	Motor Pulley	3311A1	4 Grade B6.4 SD	1	23	10.4
	Motor Pulley Bushing	GC06516	SD x 1-5/8" Bore	1	5	2.3
	Reducer Pulley	GC06676	4 Grade B8.0 SK	1	38	17.2
	Reducer Bushing	PT0778	SK x 1-3/8"	1	9	4.1
	Drive Belts	MHC00823	BX61	4	1.1	0.5
25-30 HP	Motor Pulley	MHC01566	3 Grade B11.0 SK	1	36	16.3
	Motor Pulley Bushing	CE-00617	SK x 1-7/8" Bore	1	9	4.1
	Reducer Pulley	MHC01567	3 Grade B13.6 SK	1	44	19.9
	Reducer Bushing	GC06687	SK x 1-7/16" Bore	1	9	4.1
	Drive Belts	D02-0067	BX85	3	1.1	0.5
40 HP	Motor Pulley	MHC01668	3 Grade 5V 9.0 SF	1	36	16.3
	Motor Pulley Bushing	GT3-0068	SF x 2-1/8" Bore	1	9	4.1
	Reducer Pulley	MHC01531	3 Grade 5V 11.3 SF	1	44	19.9
	Reducer Bushing	MHC01669	SF x 1-5/8" Bore	1	9	4.1
	Drive Belts	MHC00039	5VX850	3	1.2	0.5
50 HP	Motor Pulley	KD-PDS0016	4 Grade 5V 9.0 E	1	36	16.3
	Motor Pulley Bushing	MHC01540	E x 2-1/8" Bore	1	9	4.1
	Reducer Pulley	MHC01699	4 Grade 5V 11.3 E	1	44	19.9
	Reducer Bushing	MHC01537	E x 1-5/8" Bore	1	9	4.1
	Drive Belts	MHC00039	5VX850	4	1.2	0.5

12" Motor Pulleys, Bushings and Drive Belts - 60 Hz

HP	Part	Part #	Description	Qty	(Lbs)	(Kg)
30 HP	Motor Pulley	MHC01530	3 Grade 5V 8.0 SF	1	19	8.6
	Motor Pulley Bushing	MHC01162	SF x 1-7/8" Bore	1	3.8	1.7
	Reducer Pulley	MHC01531	3 Grade 5V 11.3 SF	1	25	11.3
	Reducer Bushing	GC07551	SF x 1-7/16" Bore	1	3.8	1.7
	Drive Belts	MHC00604	SVX800	3	0.9	0.4
40 HP	Motor Pulley	MHC01160	3 Grade 5V 9.25 SF	1	23	10.4
	Motor Pulley Bushing	GT3-0068	SF x 2-1/8" Bore	1	5	2.3
	Reducer Pulley	MHC01536	3 Grade 5V 13.2 E	1	38	17.2
	Reducer Bushing	MHC01537	E x 1-5/8V	1	9	4.1
	Drive Belts	MHC00475	5VX1000	3	1.1	0.5
50 HP	Motor Pulley	MHC01538	4 Grade 5V 9.25 E	1	36	16.3
	Motor Pulley Bushing	MHC01540	E x 2-1/8" Bore	1	9	4.1
	Reducer Pulley	MHC01539	4 Grade 5V 13.2 E	1	44	19.9
	Reducer Bushing	MHC01537	E x 1-5/8" Bore	1	9	4.1
	Drive Belts	MHC00475	5VX1000	4	1.1	0.5
60 HP	Motor Pulley	KD-PDS0014	4 Grade 5V 9.75 E	1	36	16.3
	Motor Pulley Bushing	017-1371-8	E x 2-3/8" Bore	1	9	4.1
	Reducer Pulley	MHC01539	4 Grade 5V 13.2 E	1	44	19.9
	Reducer Bushing	MHC01541	E x 2-3/16" Bore	1	9	4.1
	Drive Belts	MHC00477	5VX1060	4	1.2	0.5

8" (15 HP) Drive Components (8081365)

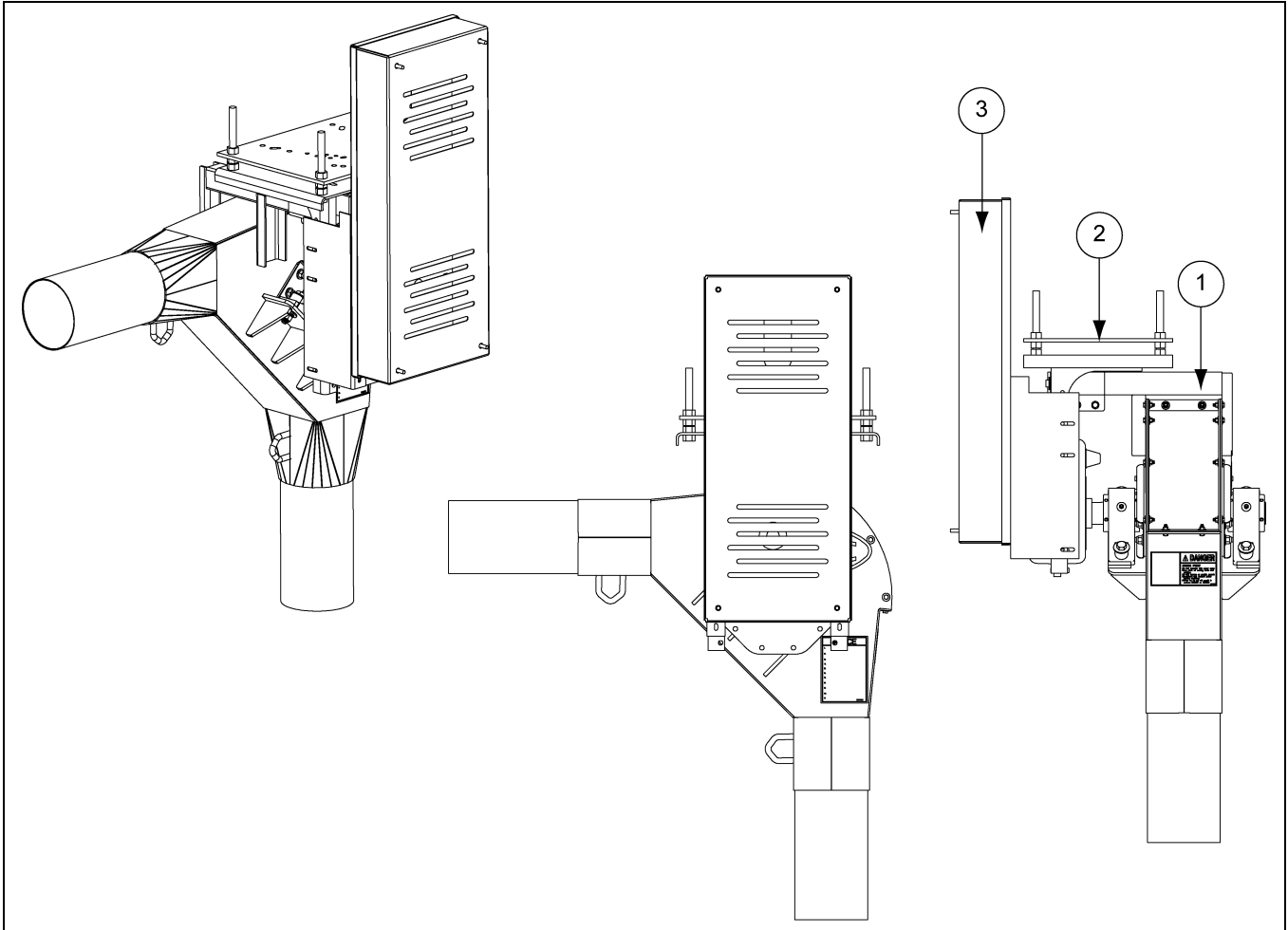

8" (15 HP) Drive Components (8081365) Parts List

Ref #	Part #	Description	Qty
1	8081362	Chain Loop: 15, 20 HP TA3 Drive Corner Assembly - 8" 207 "E" Bearing	1
2	8081271	Drive Box TA3, 15 HP, 8" and 10" Chain Loop	1
3	8120217	Belt Guard Assembly Chain Loop, TA3	1

8" (20 HP) Drive Components (8081363)

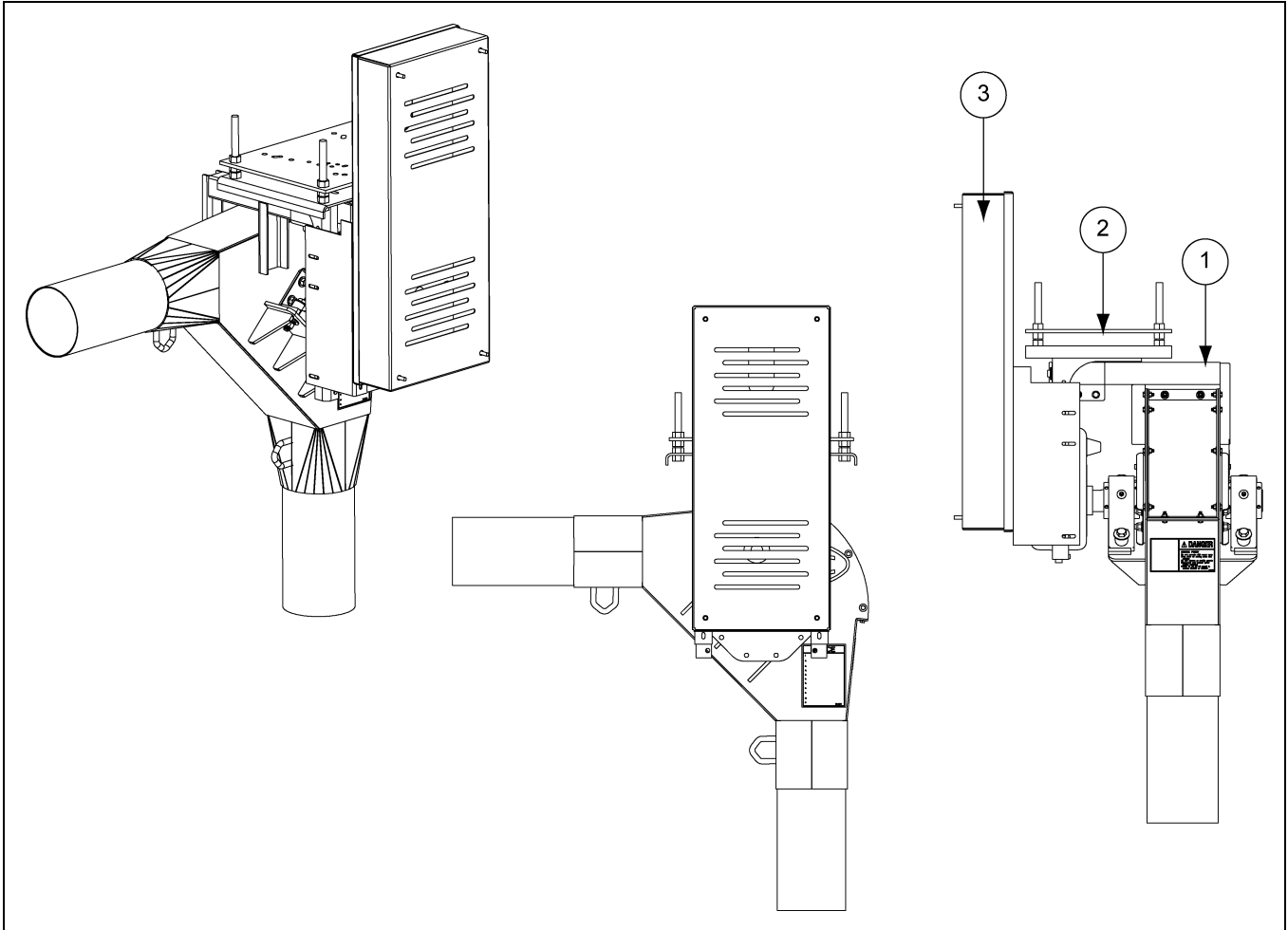

8" (20 HP) Drive Components (8081363) Parts List

Ref #	Part #	Description	Qty
1	8081362	Chain Loop: 15, 20 HP TA3 Drive Corner Assembly - 8" 207 "E" Bearing	1
2	8081285	Drive Box TA3, 20 HP, 8" and 10" Chain Loop	1
3	8120217	Belt Guard Assembly Chain Loop, TA3	1

8" (15 HP-20 HP) Drive Components (8081362)

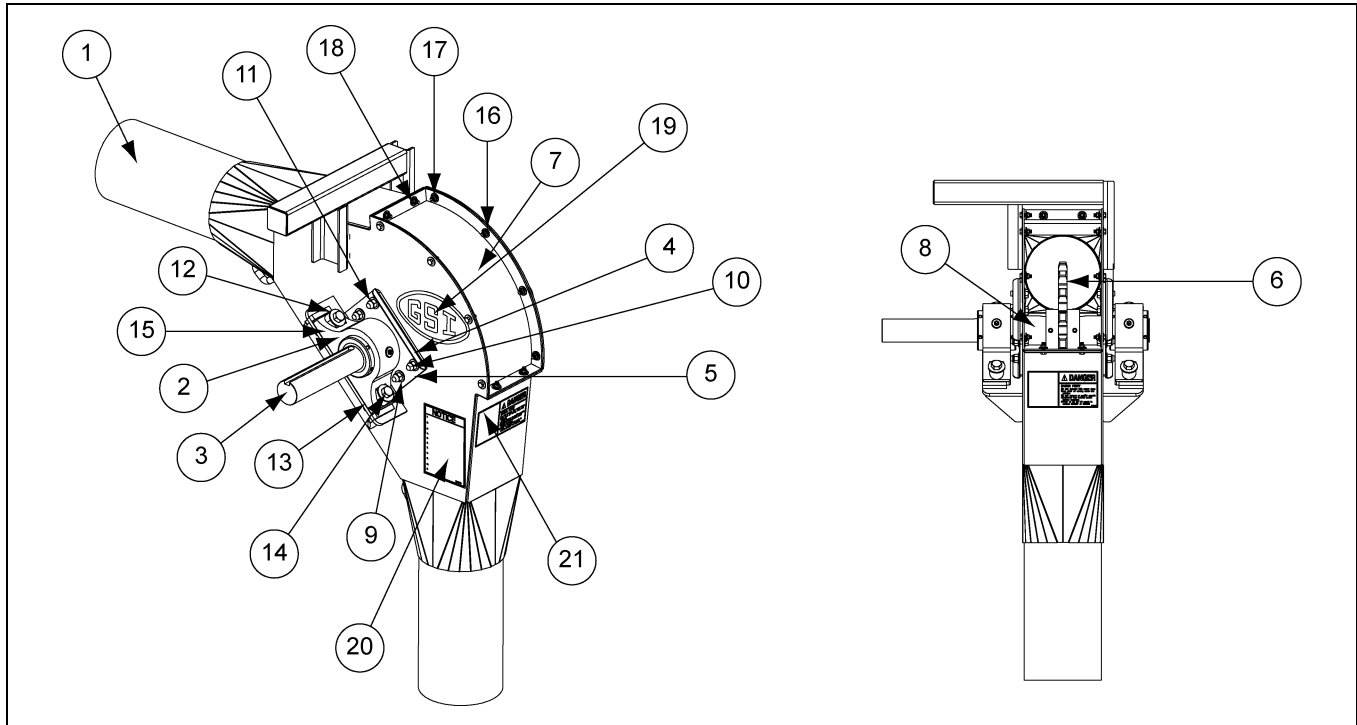

8" (15 HP-20 HP) Drive Components (8081362) Parts List

Ref #	Part #	Description	Qty
1	8081361	Chain Loop: TA3 Drive Corner Weld - 8" 207 "E" Bearing	1
2	8101510	Bearing, Taper Dodge #P2BE207R	2
3	8081364	Chain Loop: TA3 Drive Shaft - 8" 207 "E" Bearing	1
4	8081269	Corner Seal UHMW, 8" and 10" Chain Loop	2
5	8081270	Cover Plate for UHMW Bearing Seal	2
6	PT1086	Sprocket, (Hub Type) 3" I.D.	1
7	8081009	Weld, 8" Drive/Stand Corner Inspection Door	1
8	S-9177	Square Key 3/4" x 3-7/16"	1
9	S-8562	Flat Washer 1/2" GV	16
10	S-8760	Bolt, HHCS 1/2"-13 x 1-1/2" ZN Grade 5	8
11	S-8260	Nylock Nut 1/2"-13 ZN Grade 5	8
12	S-858	Flat Washer 5/8" USS ZN Grade 2	8
13	S-3208	Split Lock Washer 5/8" Med ZN Zinc	4
14	S-7011	Bolt, HHCS 5/8"-11 x 3-1/2" ZN Grade 8 Zinc	4
15	S-4110	Hex Nut 5/8"-11 YDP Grade 5	4
16	S-845	Flat Washer 5/16" USS SAE YDP Grade 2	24
17	S-1196	Bolt, HHCS 5/16"-18 x 1" ZN Grade 5	12
18	S-3611	Flange Nut 5/16"-18 YDP Grade 2	12
19	DC-1474	Decal, Logo GSI 5" x 9"	2
20	DC-1379	Decal, Notice 5-1/8" x 7-3/8"	1
21	8107001	Decal, Danger	1

10" (20 HP) Drive Components (8101526)

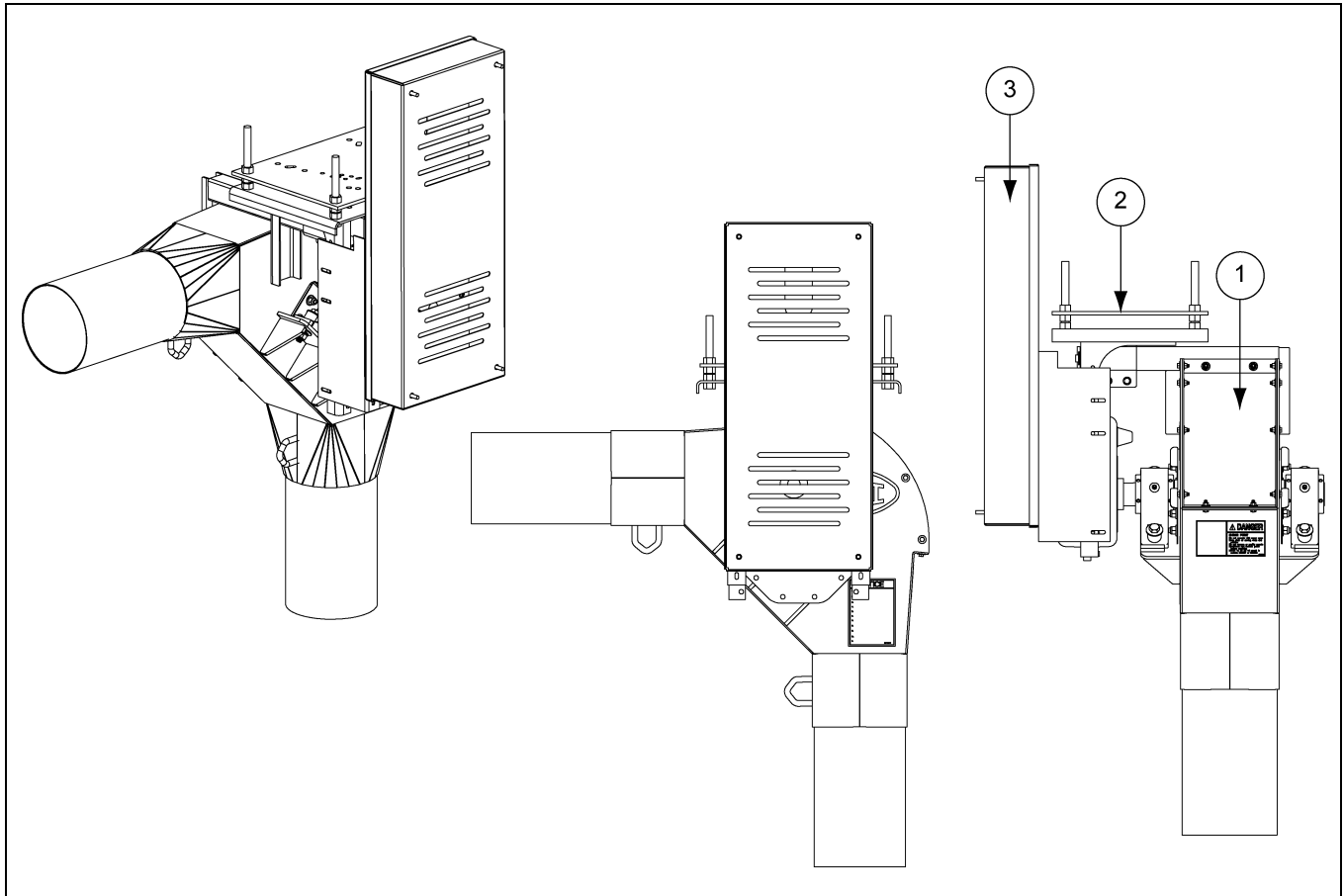

10" (20 HP) Drive Components (8101526) Parts List

Ref #	Part #	Description	Qty
1	8101525	Chain Loop: 15, 20 HP TA3 Drive Corner Assembly - 10" 207 "E" Bearing	1
2	8081285	Drive Box TA3, 20 HP, 8" and 10" Chain Loop	1
3	8120217	Belt Guard Assembly Chain Loop, TA3	1

10" (15 HP-20 HP) Drive Components (8101525)

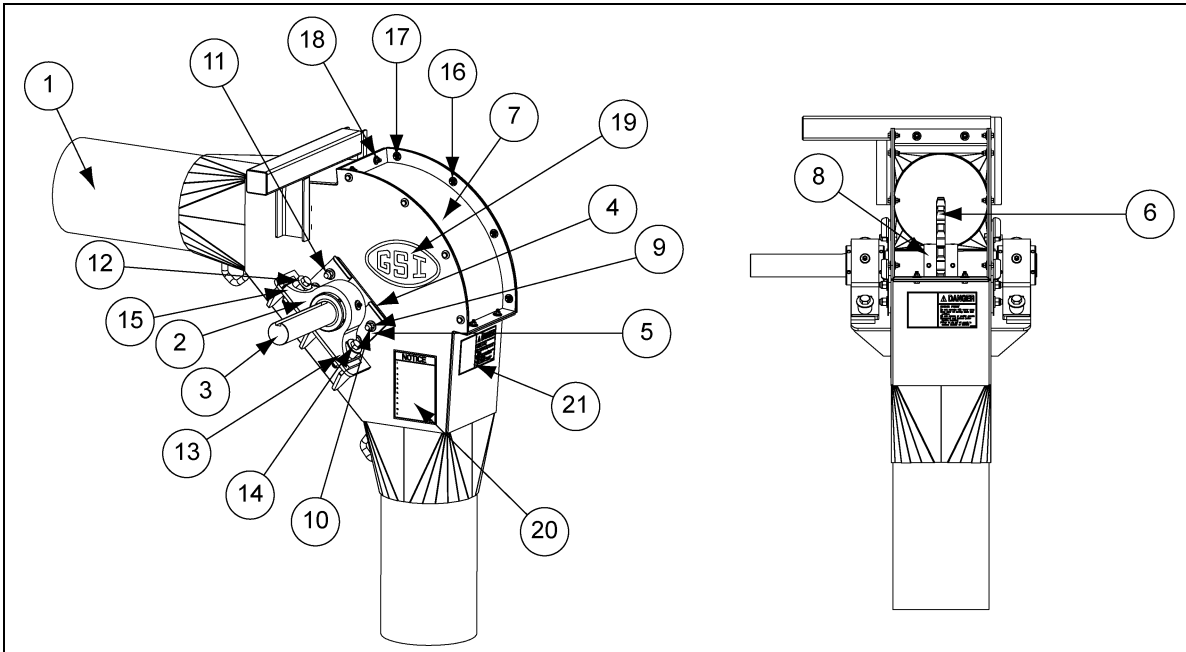

10" (15 HP-20 HP) Drive Components (8101525) Parts List

Ref #	Part #	Description	Qty
1	8101524	Chain Loop: TA3 Drive Corner Weld - 10" 207 "E" Bearing	1
2	8101510	Bearing, Taper Dodge #P2BE207R	2
3	8101527	Chain Loop: TA3 Drive Shaft - 10" 207 "E" Bearing	1
4	8081269	Corner Seal UHMW, 8" and 10" Chain Loop	2
5	8081270	Cover Plate for UHMW Bearing Seal	2
6	PT1086	Sprocket, (Hub Type) 3" I.D.	1
7	8101009	Door-Inspection, Weldment	1
8	S-9177	Square Key 3/4" x 3-7/16"	1
9	S-8562	Flat Washer 1/2" GV	16
10	S-8760	Bolt, HHCS 1/2"-13 x 1-1/2" ZN Grade 5	8
11	S-8260	Nylock Nut 1/2"-13 ZN Grade 5	8
12	S-858	Flat Washer 5/8" USS ZN Grade 2	8
13	S-3208	Split Lock Washer 5/8" Med ZN	4
14	S-7011	Bolt, HHCS 5/8"-11 x 3-1/2" ZN Grade 8 Zinc	4
15	S-4110	Hex Nut 5/8"-11 YDP Grade 5	4
16	S-845	Flat Washer 5/16" USS SAE YDP Grade 2	24
17	S-1196	Bolt, HHCS 5/16"-18 x 1" ZN Grade 5	12
18	S-3611	Flange Nut 5/16"-18 YDP Grade 2	12
19	DC-1474	Decal, Logo GSI 5" x 9"	2
20	DC-1379	Decal, Notice 5-1/8" x 7-3/8"	1
21	8107001	Decal, Danger	1

9. Parts List

8" (25 HP-30 HP) Drive Components (8081360)

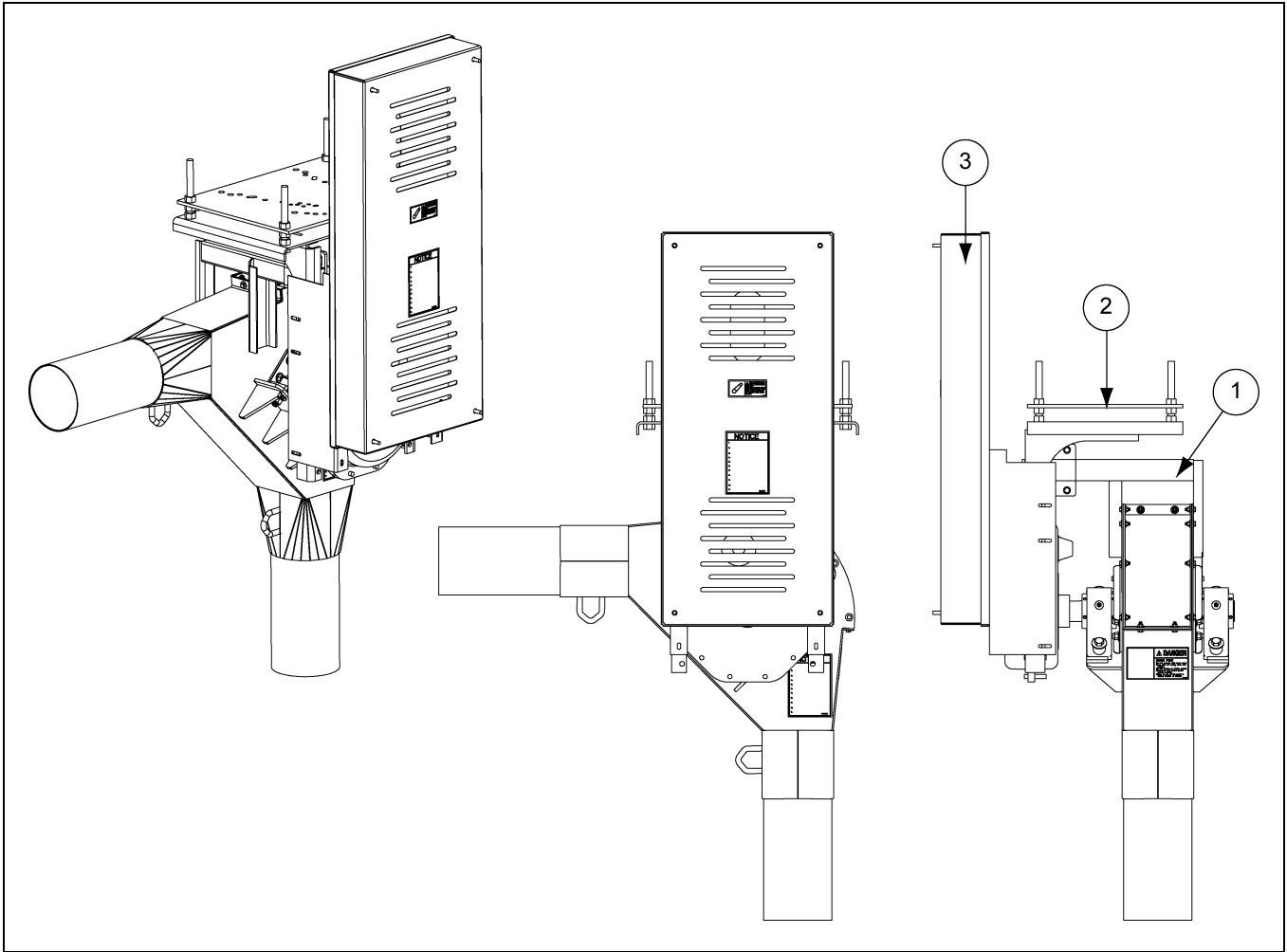

8" (25 HP-30 HP) Drive Components (8081360) Parts List

Ref #	Part #	Description	Qty
1	8081359	Chain Loop: 25, 30 HP TA4 Drive Corner Assembly - 8" 207 "E" Bearing	1
2	8081296	Drive Box TA4, 25 and 30 HP, 8" and 10" Chain Loop	1
3	8120211	Belt Guard Assembly Chain Loop, TA4	1

8" (25 HP-30 HP) Drive Components (8081359)

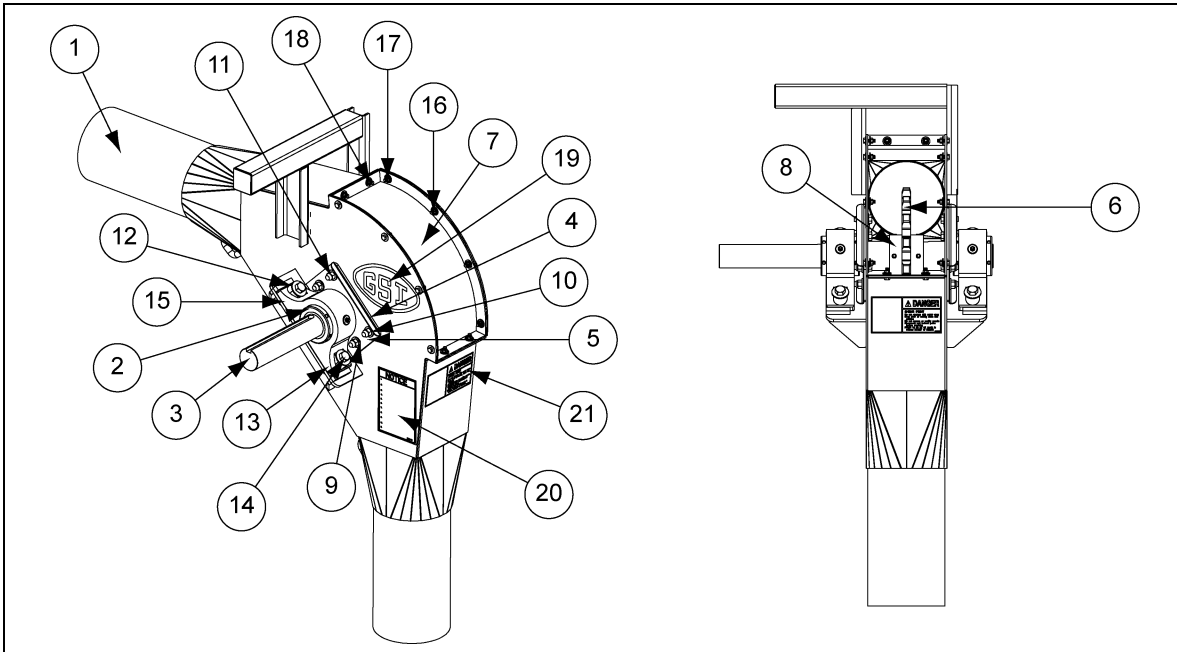

8" (25 HP-30 HP) Drive Components (8081359) Parts List

Ref #	Part #	Description	Qty
1	8081358	Chain Loop: TA4 Drive Corner Weld - 8" 207 "E" Bearing	1
2	8101510	Bearing, Taper Dodge #P2BE207R	2
3	8081355	Chain Loop: TA4 Drive Shaft - 8" 207 "E" Bearing	1
4	8081269	Corner Seal UHMW, 8" and 10" Chain Loop	2
5	8081270	Cover Plate for UHMW Bearing Seal	2
6	PT1086	Sprocket, (Hub Type) 3" I.D.	1
7	8081009	Weld, 8" Drive/Stand Corner Inspection Door	1
8	S-9177	Square Key 3/4" x 3-7/16"	1
9	S-8562	Flat Washer 1/2" GV	16
10	S-8760	Bolt, HHCS 1/2"-13 x 1-1/2" ZN Grade 5	8
11	S-8260	Nylock Nut 1/2"-13 ZN Grade 5	8
12	S-858	Flat Washer 5/8" USS ZN Grade 2	8
13	S-3208	Split Lock Washer 5/8" Med ZN	4
14	S-7011	Bolt, HHCS 5/8"-11 x 3-1/2" ZN Grade 8 Zinc	4
15	S-4110	Hex Nut 5/8"-11 YDP Grade 5	4
16	S-845	Flat Washer 5/16" USS SAE YDP Grade 2	24
17	S-1196	Bolt, HHCS 5/16"-18 x 1" ZN Grade 5	12
18	S-3611	Flange Nut 5/16"-18 YDP Grade 2	12
19	DC-1474	Decal, Logo GSI 5" x 9"	2
20	DC-1379	Decal, Notice 5-1/8" x 7-3/8"	1
21	8107001	Decal, Danger	1

10" (25 HP-30 HP) Drive Components (8101517)

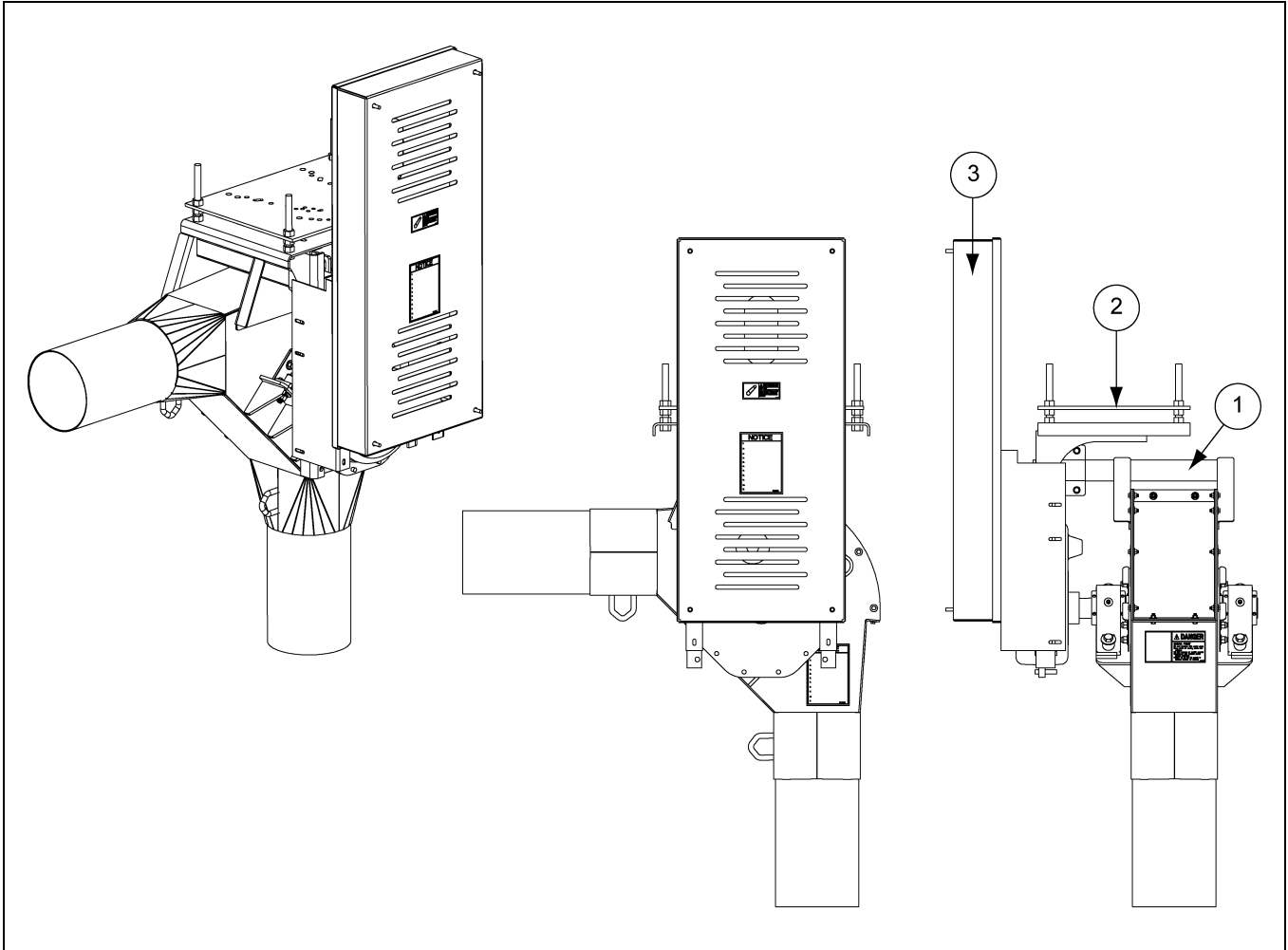

10" (25 HP-30 HP) Drive Components (8101517) Parts List

Ref #	Part #	Description	Qty
1	8101516	Chain Loop: 25, 30 HP TA4 Drive Corner Assembly - 10" 207 "E" Bearing	1
2	8081296	Drive Box TA4, 25 and 30 HP, 8" and 10" Chain Loop	1
3	8120211	Belt Guard Assembly Chain Loop, TA4	1

10" (25 HP-30 HP) Drive Components (8101516)

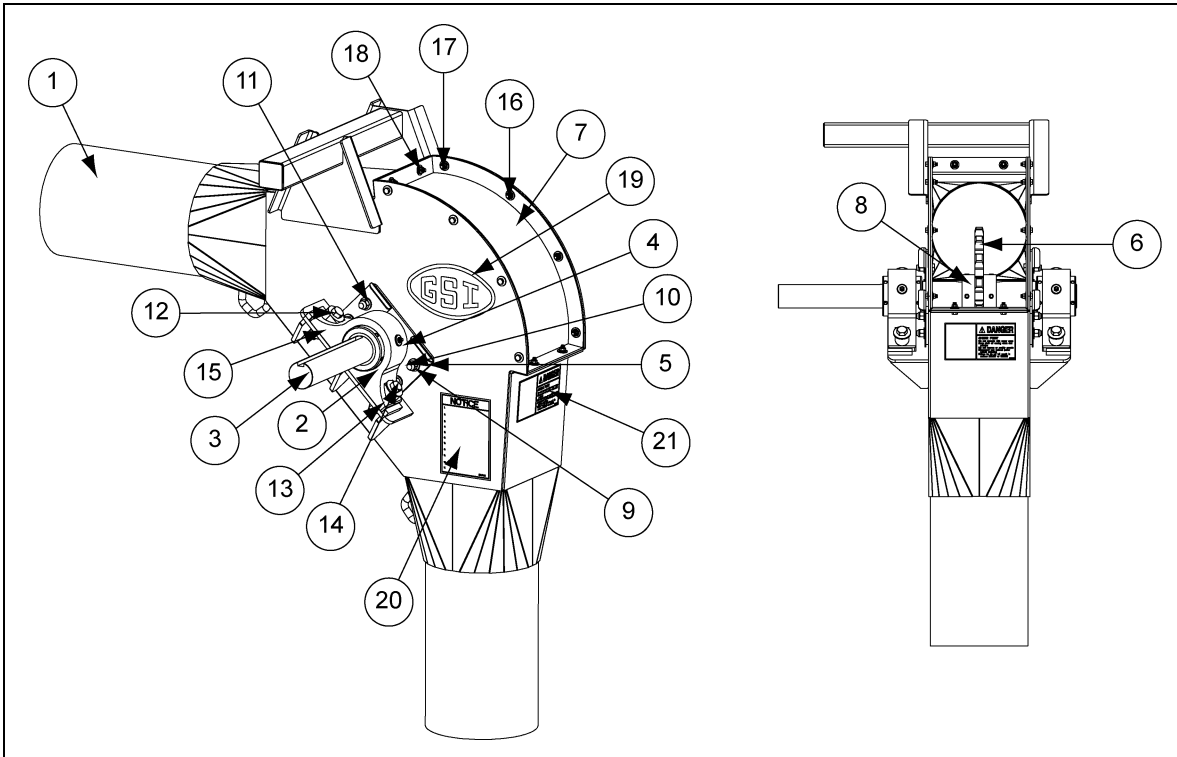

10" (25 HP-30 HP) Drive Components (8101516) Parts List

Ref #	Part #	Description	Qty
1	8101515	Chain Loop: TA4 Drive Corner Weld - 10" 207 "E" Bearing	1
2	8101510	Bearing, Taper Dodge #P2BE207R	2
3	8101518	Chain Loop: TA4 Drive Shaft - 10" 207 "E" Bearing	1
4	8081269	Corner Seal UHMW, 8" and 10" Chain Loop	2
5	8081270	Cover Plate for UHMW Bearing Seal	2
6	PT1086	Sprocket, (Hub Type) 3" I.D.	1
7	8101009	Door-Inspection, Weldment	1
8	S-9177	Square Key 3/4" x 3-7/16"	1
9	S-8562	Flat Washer 1/2" GV	16
10	S-8760	Bolt, HHCS 1/2"-13 x 1-1/2" ZN Grade 5	8
11	S-8260	Nylock Nut 1/2"-13 ZN Grade 5	8
12	S-858	Flat Washer 5/8" USS ZN Grade 2	8
13	S-3208	Split Lock Washer 5/8" Med ZN	4
14	S-7011	Bolt, HHCS 5/8"-11 x 3-1/2" ZN Grade 8 Zinc	4
15	S-4110	Hex Nut 5/8"-11 YDP Grade 5	4
16	S-845	Flat Washer 5/16" USS SAE YDP Grade 2	24
17	S-1196	Bolt, HHCS 5/16"-18 x 1" ZN Grade 5	12
18	S-3611	Flange Nut 5/16"-18 YDP Grade 2	12
19	DC-1474	Decal, Logo GSI 5" x 9"	2
20	DC-1379	Decal, Notice 5-1/8" x 7-3/8"	1
21	8107001	Decal, Danger	1

10" (40 HP) Drive Components (8101513)

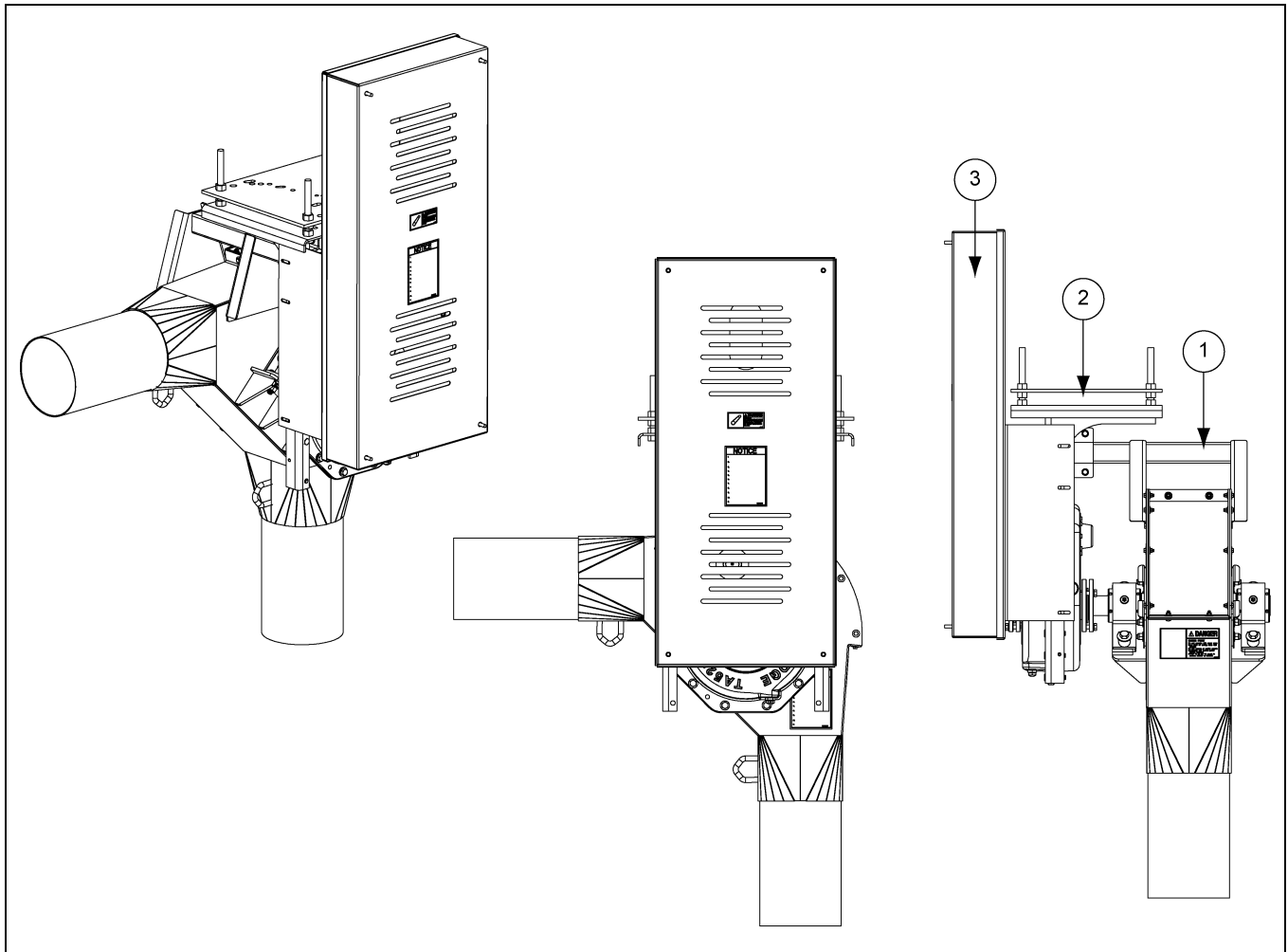

10" (40 HP) Drive Components (8101513) Parts List

Ref #	Part #	Description	Qty
1	8101511	Chain Loop: 40, 50 HP TA5 Drive Corner Assembly - 10" 207 "E" Bearing	1
2	8101303	Drive Box TA5, 40 HP, 10" Chain Loop	1
3	8120214	Belt Guard Assembly Chain Loop, TA5	1

10" (50 HP) Drive Components (8101514)

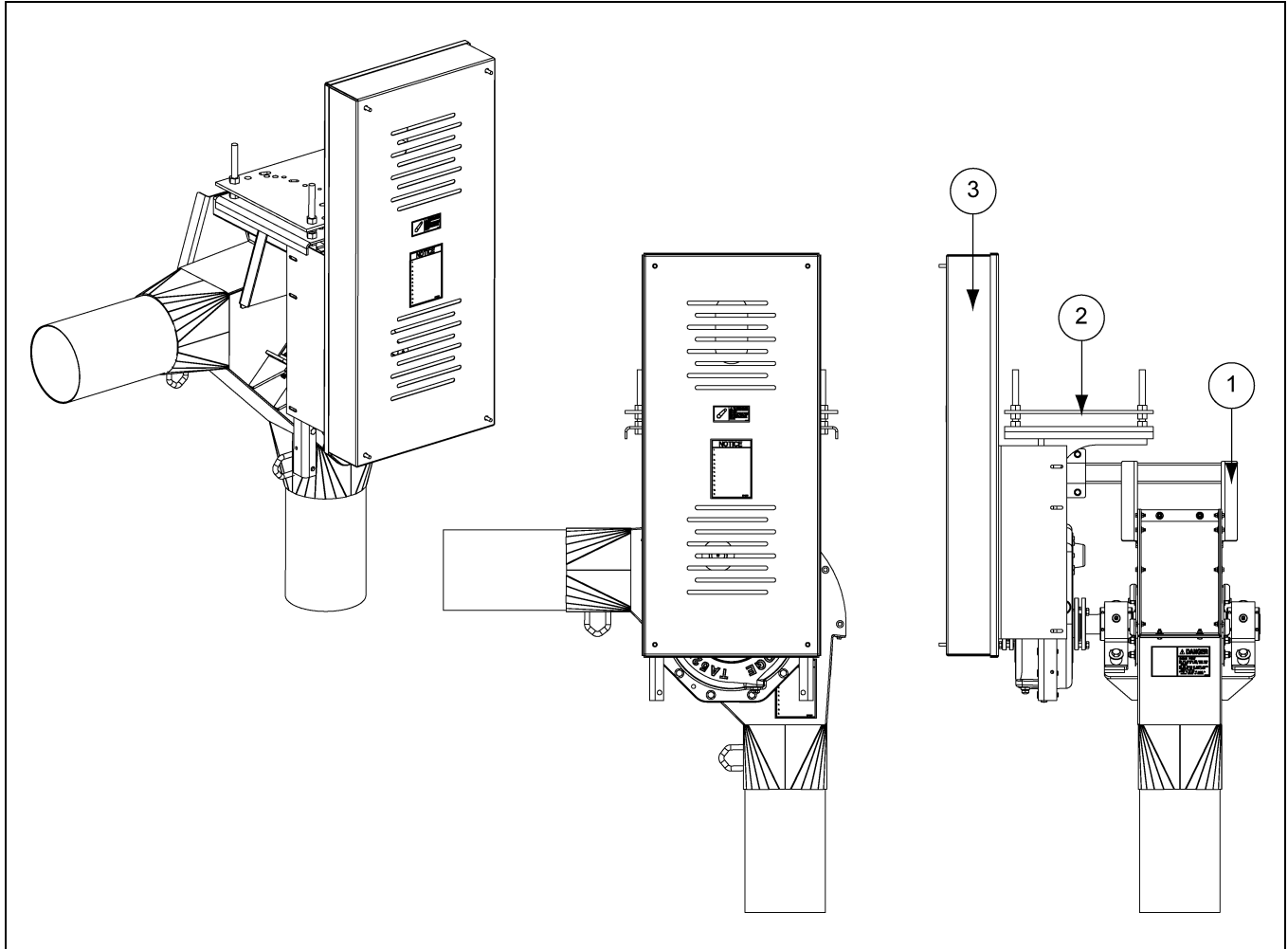

10" (50 HP) Drive Components (8101514) Parts List

Ref #	Part #	Description	Qty
1	8101511	Chain Loop: 40, 50 HP TA5 Drive Corner Assembly - 10" 207 "E" Bearing	1
2	8101331	Drive Box TA5, 50 HP, 10" Chain Loop	1
3	8120214	Belt Guard Assembly Chain Loop, TA5	1

9. Parts List

10" (40 HP-50 HP) Drive Components (8101511)

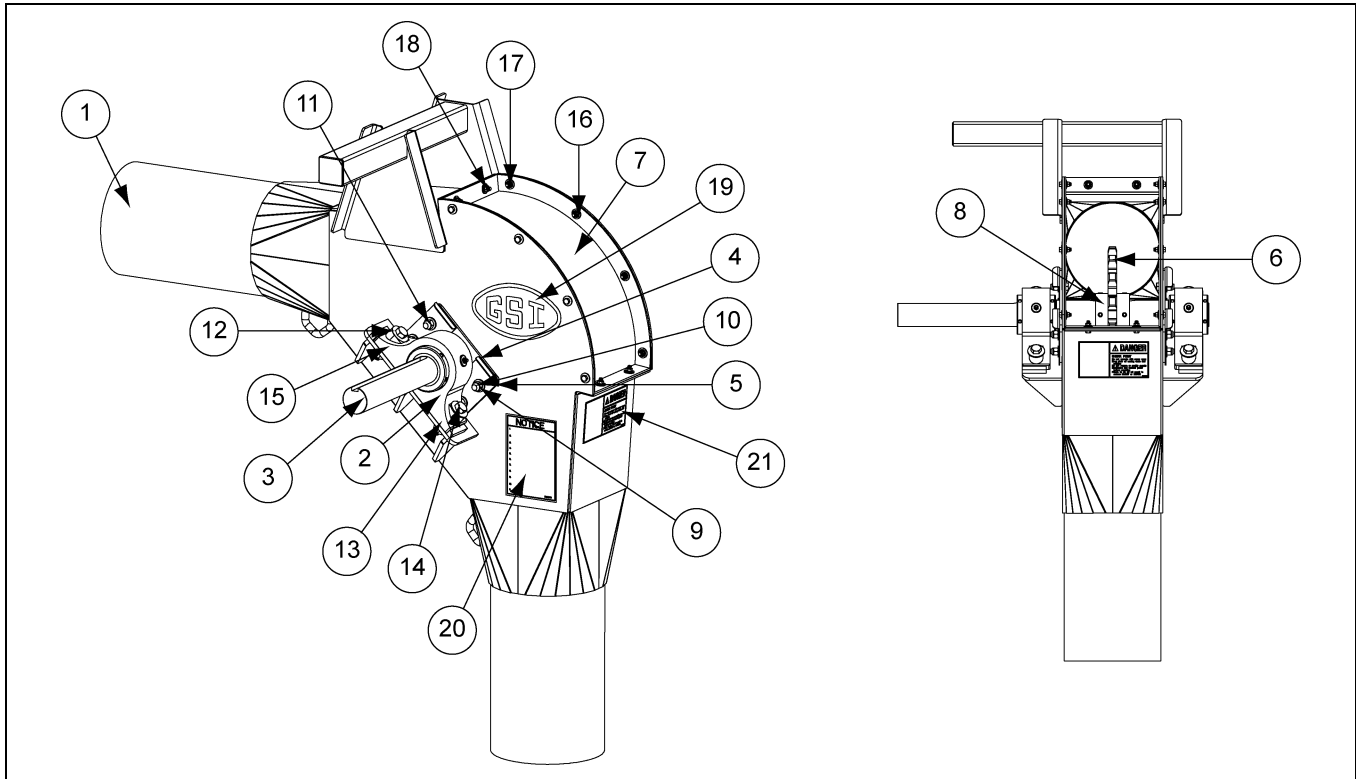

10" (40 HP-50 HP) Drive Components (8101511) Parts List

Ref #	Part #	Description	Qty
1	8101509	Chain Loop: TA5 Drive Corner Weld - 10" 207 "E" Bearing	1
2	8101510	Bearing, Taper Dodge #P2BE207R	2
3	8101512	Chain Loop: TA5 Drive Shaft-10" 207 "E" Bearing	1
4	8081269	Corner Seal UHMW, 8" and 10" Chain Loop	2
5	8081270	Cover Plate for UHMW Bearing Seal	2
6	PT1086	Sprocket, (Hub Type) 3" I.D.	1
7	8101009	Door-Inspection, Weldment	1
8	S-9177	Square Key 3/4" x 3-7/16"	1
9	S-8562	Flat Washer 1/2" GV	16
10	S-8760	Bolt, HHCS 1/2"-13 x 1-1/2" ZN Grade 5	8
11	S-8260	Nylock Nut 1/2"-13 ZN Grade 5	8
12	S-858	Flat Washer 5/8" USS ZN Grade 2	8
13	S-3208	Split Lock Washer 5/8" Med ZN	4
14	S-7011	Bolt, HHCS 5/8"-11 x 3-1/2" ZN Grade 8 Zinc	4
15	S-4110	Hex Nut 5/8"-11 YDP Grade 5	4
16	S-845	Flat Washer 5/16" USS SAE YDP Grade 2	24
17	S-1196	Bolt, HHCS 5/16"-18 x 1" ZN Grade 5	12
18	S-3611	Flange Nut 5/16"-18 YDP Grade 2	12
19	DC-1474	Decal, Logo GSI 5" x 9"	2
20	DC-1379	Decal, Notice 5-1/8" x 7-3/8"	1
21	8107001	Decal, Danger	1

8" (15 HP) Drive Components (8081271)

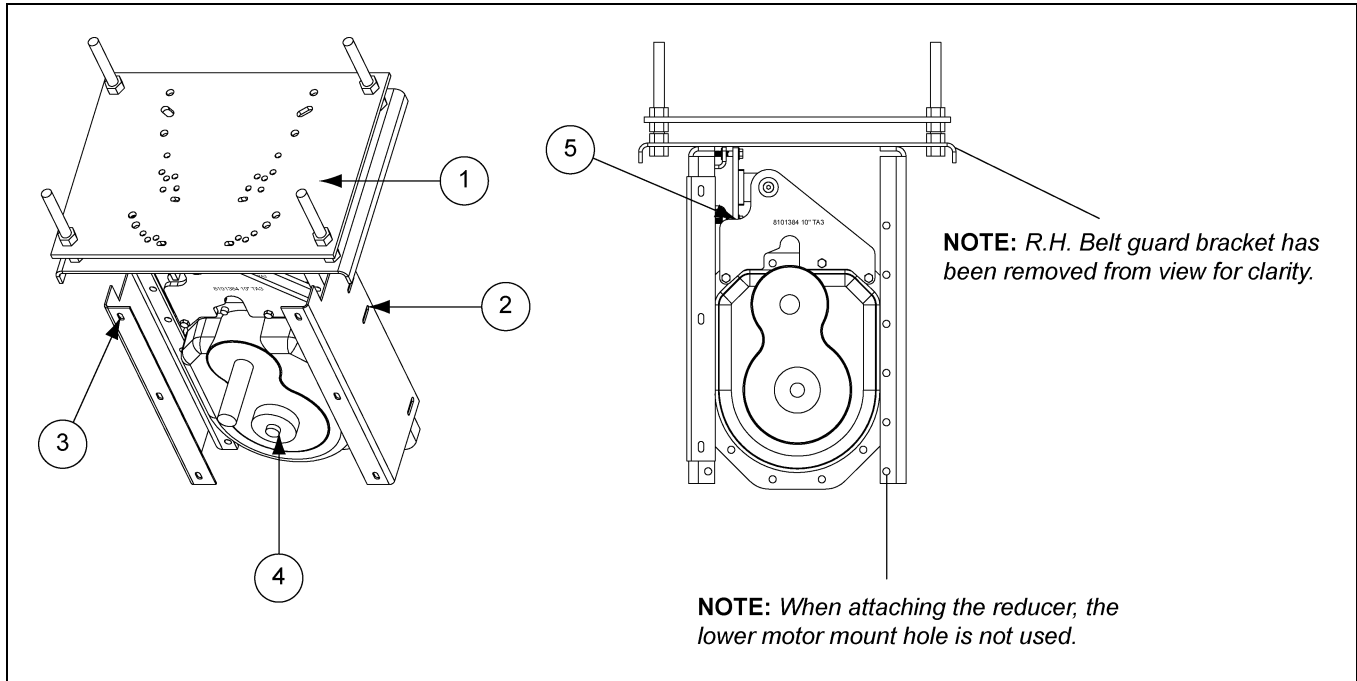

8" (15 HP) Drive Components (8081271) Parts List

Ref #	Part #	Description	Qty
1	TA3CLMM	Motor Mount, Chain Loop TA3	1
2	BG-0167	Belt Guard Bracket, R.H., TA3	1
3	BG-0168	Belt Guard Bracket, L.H., TA3	1
4	MHC01074	Shaft, Reducer Dodge #TA3203H15	1
5	8081324	TA3 Torque Plate Kit 8", 10" Loop	1
N/S	CE-00582	Sheave, 3 Grade, A6.0-B6.4 - SD, 6-3/4" O.D.	1
N/S	GC06516	Bushing, SD x 1-5/8" Bore	1
N/S	GC07874	Sheave, 3 Grade, A7.6-B8.0 - SK, 8.35" O.D.	1
N/S	MHC00823	Belt, V BX61	3
N/S	MHC01094	Bushing, Taper, TA3203TB x 2-3/16 Dodge # 903022	1
N/S	PT0778	Bushing, SK 1-3/8" Bore QD Style	1
N/S	TA3HDW	Hardware, Belt Guard TA3	1
N/S	8101336	Vent Elbow Kit 3/8" with Instructions	1

9. Parts List

8" (20 HP) Drive Components (8081285)

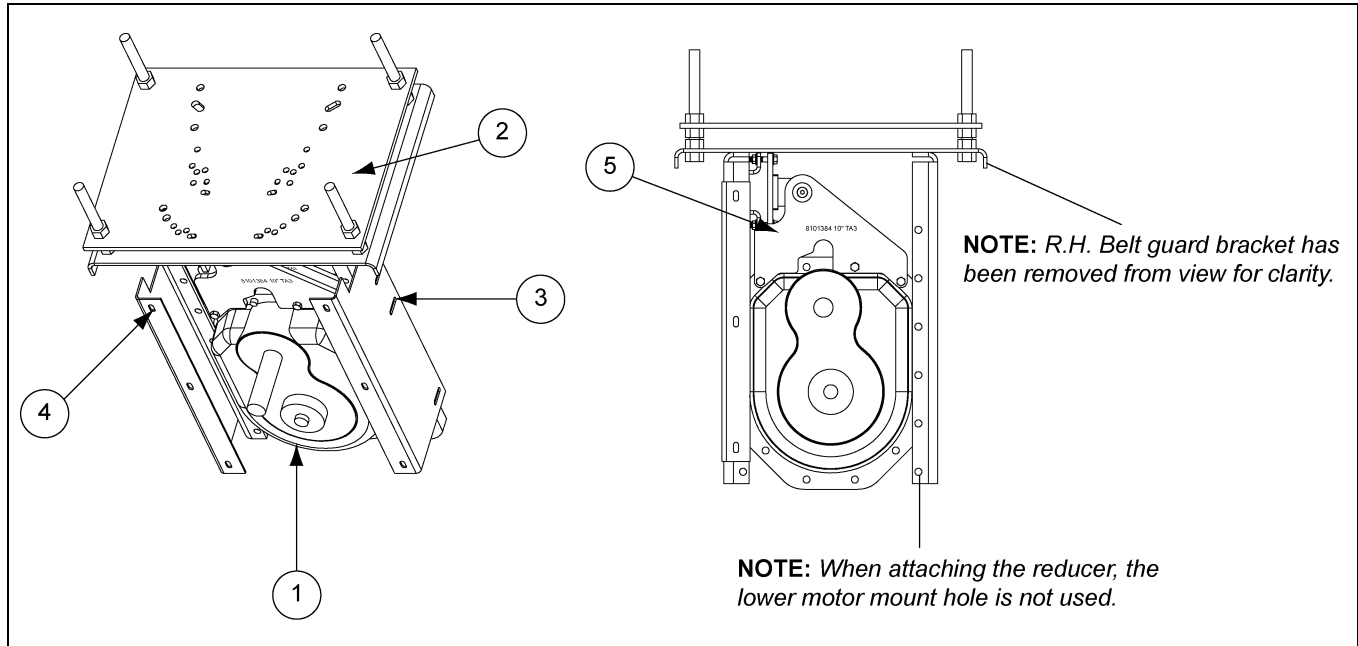

8" (20 HP) Drive Components (8081285) Parts List

Ref #	Part #	Description	Qty
1	MHC01074	Shaft, Reducer Dodge #TA3203H15	1
2	TA3CLMM	Motor Mount, Chain Loop TA3	1
3	BG-0167	Belt Guard Bracket, R.H., TA3	1
4	BG-0168	Belt Guard Bracket, L.H., TA3	1
5	8081324	TA3 Torque Plate Kit 8", 10" Loop	1
N/S	3311A1	Sheave, 4 Grade, A6.0-B6.4 -SD, 6-3/4" O.D.	1
N/S	GC06516	Bushing, SD x 1-5/8" Bore	1
N/S	GC06676	Sheave, 4 Grade, A7.6-B8.0 - SK, 8.35" O.D.	1
N/S	MHC00823	Belt, V BX61	4
N/S	MHC01094	Bushing, Taper, TA3203TB x 2-3/16 Dodge # 903022	1
N/S	PT0778	Bushing, SK 1-3/8" Bore QD Style	1
N/S	TA3HDW	Hardware, Belt Guard TA3	1
N/S	8101336	Vent Elbow Kit 3/8" with Instructions	1

8"-10" (25 HP-30 HP) Drive Components (8081296)

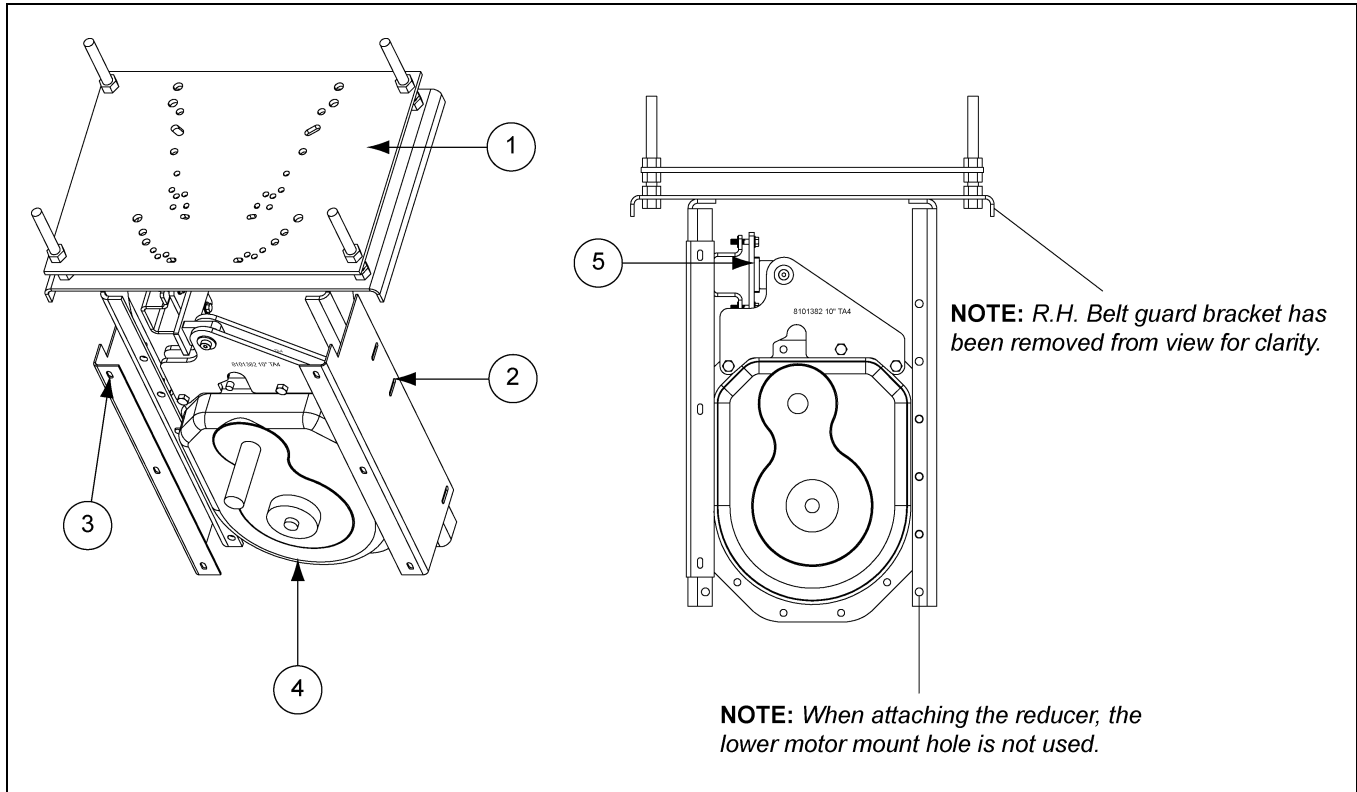

8"-10" (25 HP-30 HP) Drive Components (8081296) Parts List

Ref #	Part #	Description	Qty
1	TA4CLMM	Motor Mount, Chain Loop TA4	1
2	BG-0181	Belt Guard Bracket, R.H., TA4	1
3	BG-0182	Belt Guard Bracket, L.H., TA4	1
4	MHC01075	Shaft, Reducer Dodge #TA4207H15	1
5	8101424	TA4 Torque Plate Kit 8", 10" Loop	1
N/S	CE-00617	Bushing, SK 1-7/8" Bore	1
N/S	D02-0067	Belt, V BX85 Replaces 717-1346-5	3
N/S	GC06687	Bushing, SK x 1-7/16" Bore	1
N/S	MHC01096	Bushing, Taper, TA4207TB x 2-7/16	1
N/S	MHC01566	Sheave, 3 Garde, A10.6-B11.0 - SK, 11.35" O.D.	1
N/S	MHC01567	Sheave, 3 Grade, A13.2-B13.6 - SK, 13.95" O.D.	1
N/S	TA4HDW	Hardware, Belt Guard TA4	1
N/S	8101334	Vent Elbow Kit 1/2"	1

9. Parts List

10" (40 HP) Drive Components (8101303)

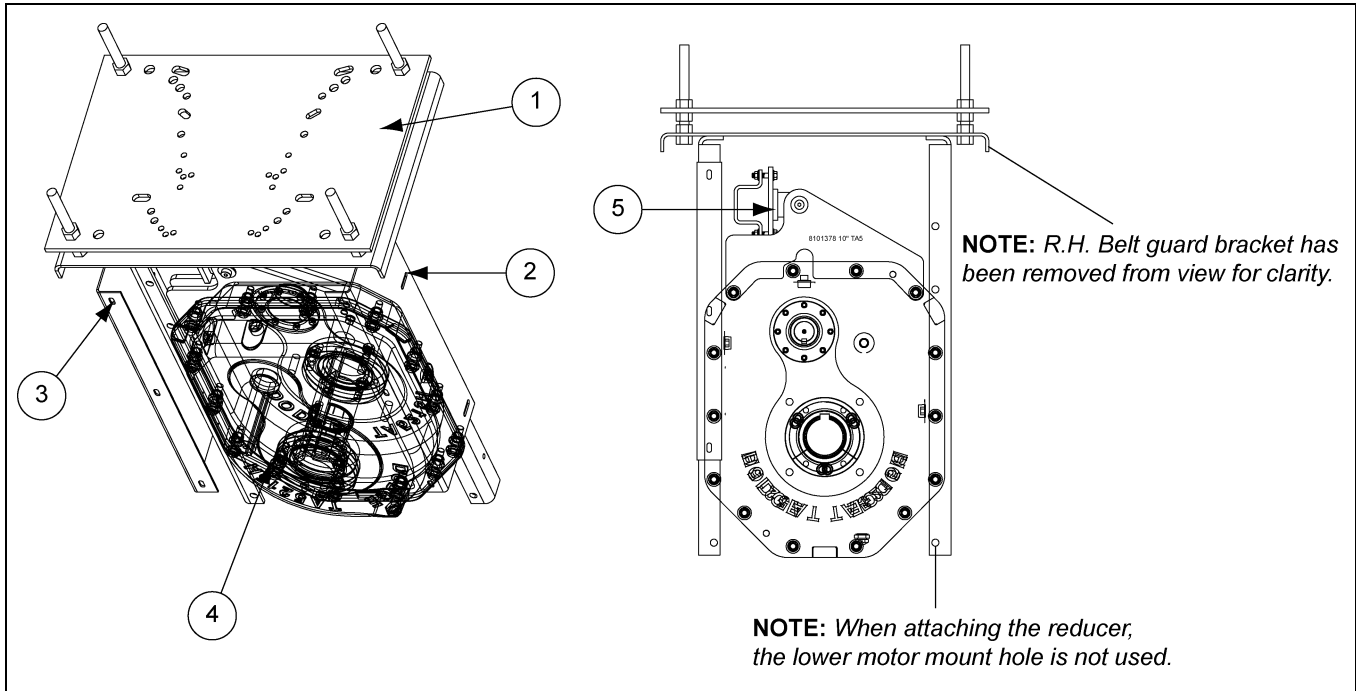

10" (40 HP) Drive Components (8101303) Parts List

Ref #	Part #	Description	Qty
1	TA5CLMM	Motor Mount, Chain Loop TA5	1
2	BG-0196	Belt Guard Bracket, R.H., TA5	1
3	BG-0197	Belt Guard Bracket, L.H., TA5	1
4	MHC01076	Shaft, Reducer Dodge #TA4207H15	1
5	8101425	TA5 Torque Plate Kit 8", 10" Loop	1
N/S	GT3-0068	Bushing, SF 2-1/8" Bore	1
N/S	MHC00039	Belt, V 5VX-850	3
N/S	MHC01097	Bushing, Taper, TA5215TB x 2-7/16	1
N/S	MHC01531	Sheave, 3 Grade 5V 11.3-SF QD	1
N/S	MHC01668	Sheave, 3 Grade 5V 9.0SF QD	1
N/S	MHC01669	Bushing, SF x 1-5/8" Bore QD	1
N/S	TA5HDW	Hardware, Belt Guard TA5	1
N/S	8101334	Vent Elbow Kit 1/2"	1

10" (50 HP) Drive Components (8101331)

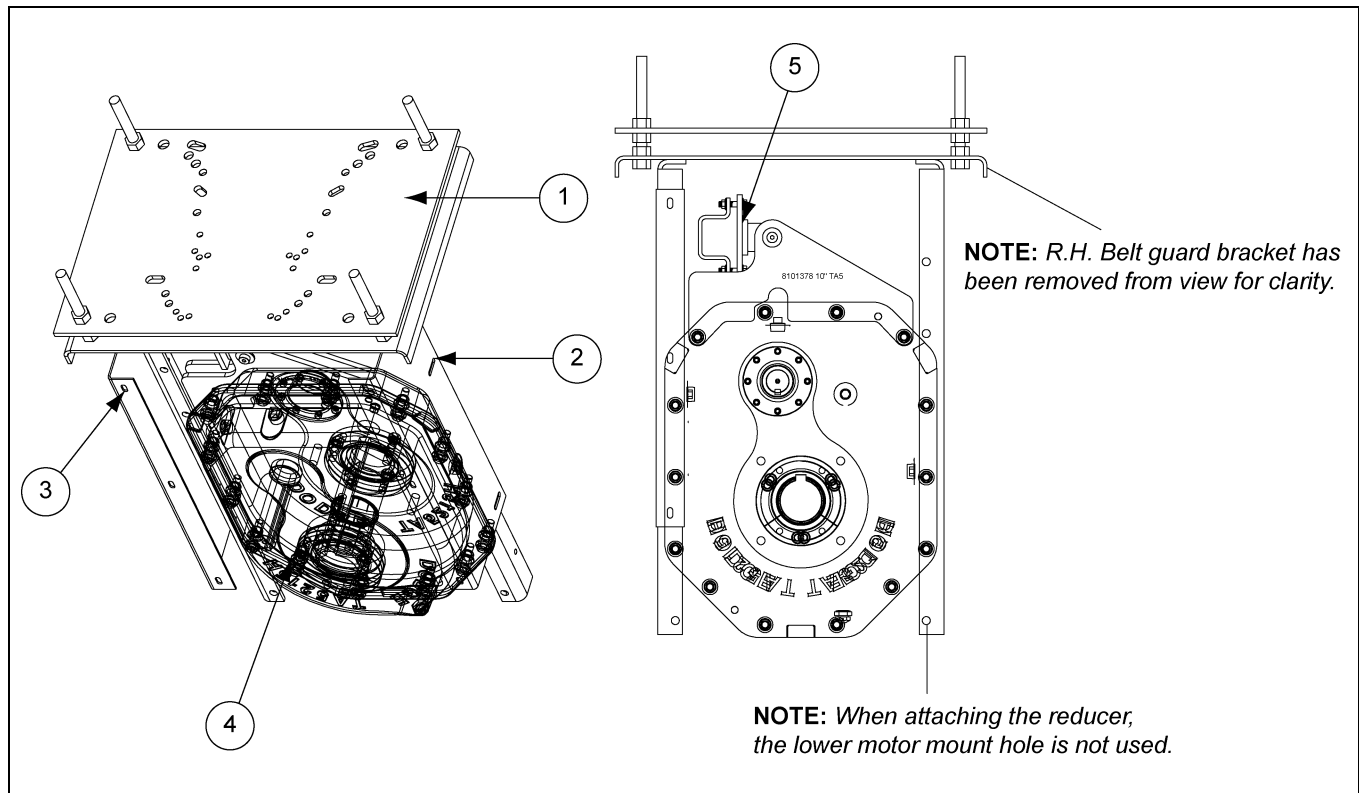

10" (50 HP) Drive Components (8101331) Parts List

Ref #	Part #	Description	Qty
1	TA5CLMM	Motor Mount, Chain Loop TA5	1
2	BG-0196	Belt Guard Bracket, R.H., TA5	1
3	BG-0197	Belt Guard Bracket, L.H., TA5	1
4	MHC01076	Shaft, Reducer Dodge #TA4207H15	1
5	8101425	TA5 Torque Plate Kit 8", 10" Loop	1
N/S	MHC01540	Bushing, E x 2-1/8" Bore QD	1
N/S	MHC00039	Belt, V 5VX-850	4
N/S	MHC01097	Bushing, Taper, TA5215TB x 2-7/16	1
N/S	MHC01699	Sheave, 4 Grade 5V 11.3" QD "E"	1
N/S	KD-PDS0016	Sheave, 4 Grade 5V 9.0" QD "E"	1
N/S	MHC01537	Bushing, E x 1-5/8" Bore QD	1
N/S	TA5HDW	Hardware, Belt Guard TA5	1
N/S	8101334	Vent Elbow Kit 1/2"	1

Belt Guard Assembly TA3 (8120217)

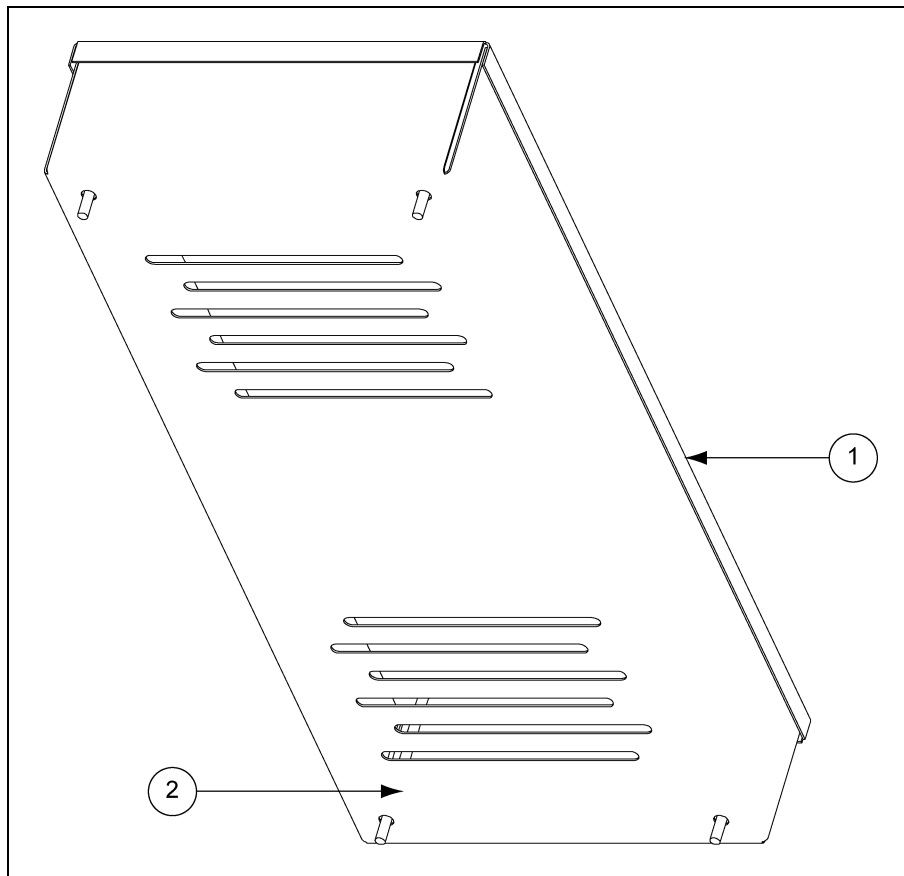

Belt Guard Assembly TA3 (8120217) Parts List

Ref #	Part #	Description	Qty
1	8120216	Belt Guard Back Weld Chain Loop, TA3	1
2	8120222	Belt Guard Cover Weld Chain Loop, TA3	1
N/S	S-1054	Split Lock Washer 3/8" ZN	4
N/S	S-248	Flat Washer 3/8" 7/16" I.D. 1" O.D. YDP	4
N/S	S-456	Hex Nut 3/8"-16 YDP Grade 5	4
N/S	DC-994	Decal, Danger Shear Point	1
N/S	DC-995	Decal, Warning Shear Point	1
N/S	DC-1379	Decal, Notice 5-1/8" x 7-3/8"	1

NOTES

Belt Guard Assembly TA4 (8120211)

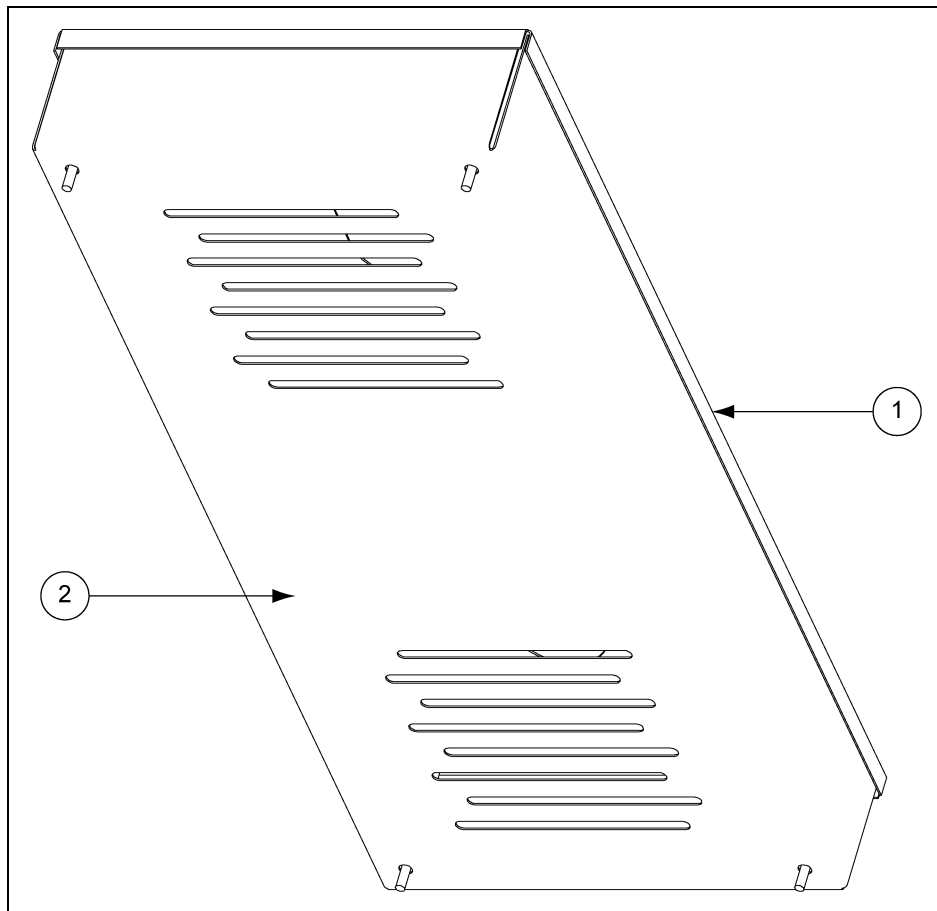

Belt Guard Assembly TA4 (8120211) Parts List

Ref #	Part #	Description	Qty
1	8120210	Belt Guard Back Weld Chain Loop, TA4	1
2	8120220	Belt Guard Cover Weld Chain Loop, TA4	1
N/S	S-1054	Split Lock Washer 3/8" ZN	4
N/S	S-248	Flat Washer 3/8" 7/16" I.D. 1" O.D. YDP	4
N/S	S-456	Hex Nut 3/8"-16 YDP Grade 5	4
N/S	DC-994	Decal, Danger Shear Point	1
N/S	DC-995	Decal, Warning Shear Point	1
N/S	DC-1379	Decal, Notice 5-1/8" x 7-3/8"	1

Belt Guard Assembly TA5 (8120214)

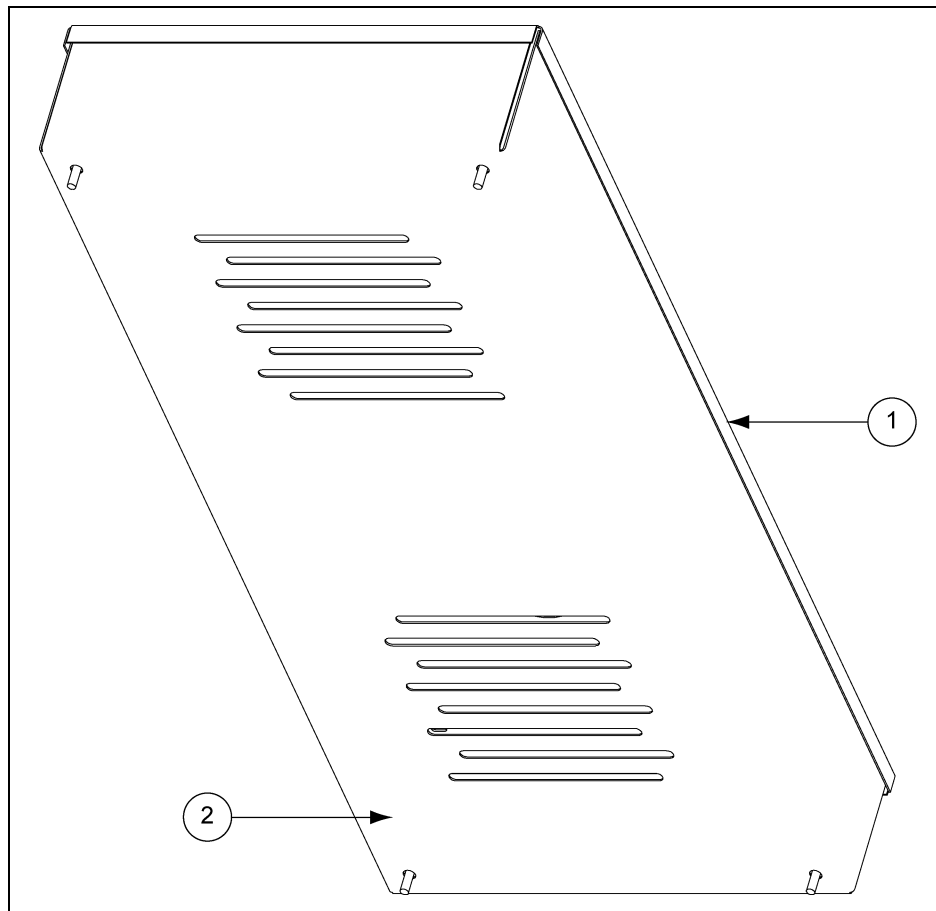

Belt Guard Assembly TA5 (8120214) Parts List

Ref #	Part #	Description	Qty
1	8120213	Belt Guard Back Weld Chain Loop, TA5	1
2	8120218	Belt Guard Cover Weld Chain Loop, TA5	1
N/S	S-1054	Split Lock Washer 3/8" ZN	4
N/S	S-248	Flat Washer 3/8" 7/16" I.D. 1" O.D. YDP	4
N/S	S-456	Hex Nut 3/8"-16 YDP Grade 5	4
N/S	DC-994	Decal, Danger Shear Point	1
N/S	DC-995	Decal, Warning Shear Point	1
N/S	DC-1379	Decal, Notice 5-1/8" x 7-3/8"	1

12" 7 Gauge (30 HP) Drive Components (8120000)

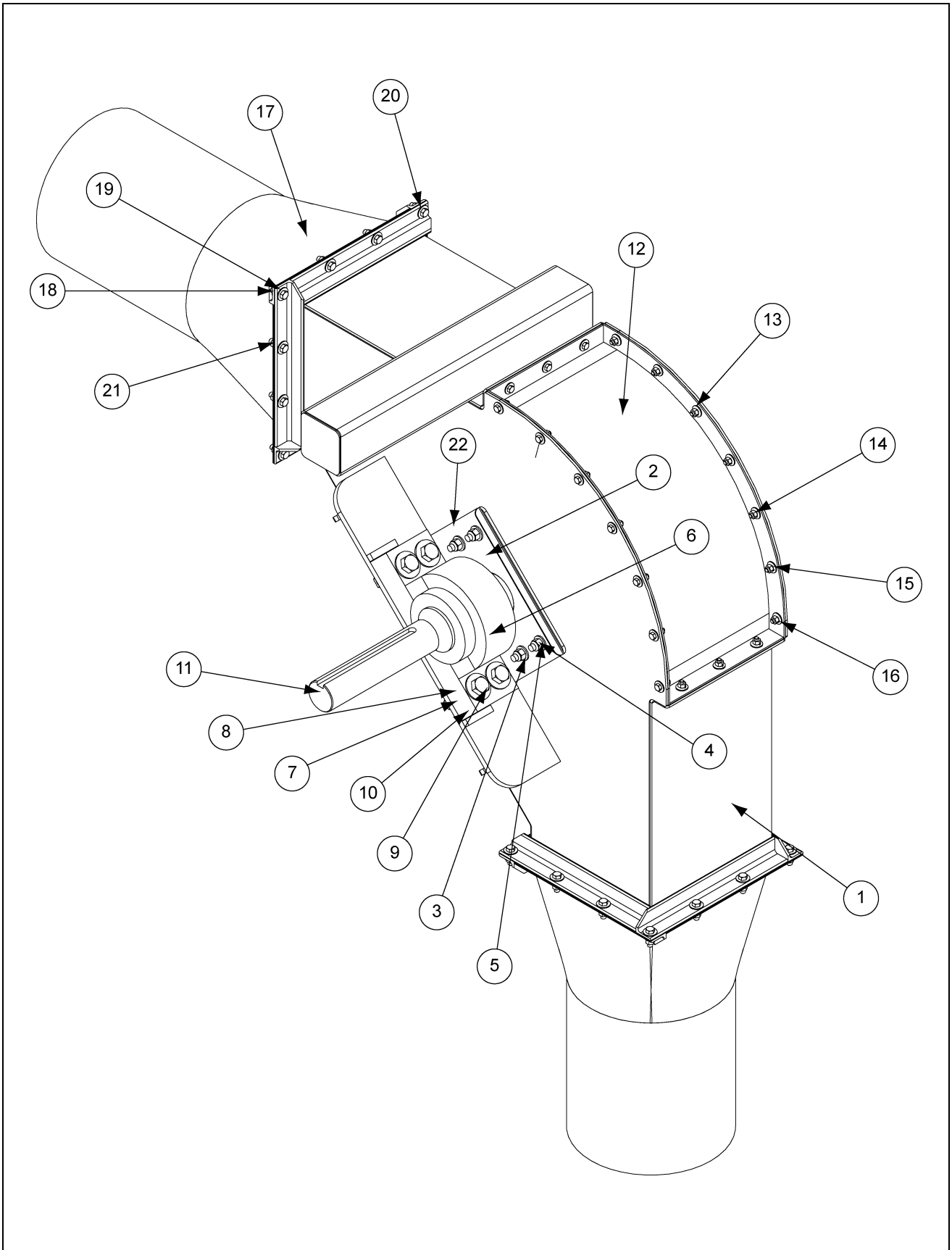

12" 7 Gauge (30 HP) Drive Components (8120000) Parts List

Ref #	Part #	Description	Qty
1	8120027	TA4 Drive Corner Weld - 12" Chain Loop	1
2	8120010	Corner Seal UHMW, 12" Chain Loop	2
3	S-8760	Bolt, HHCS 1/2"-13 x 1-1/2" ZN Grade 5	8
4	S-8562	Flat Washer 1/2" GV	8
5	S-8260	Nylock Nut 1/2"-13 ZN Grade 5	8
6	MHC01277	Bearing, Dodge# P4B-S2-307R	2
7	S-866	Flat Washer 3/4" USS ZN Flat Grade 2	16
8	S-233	Split Lock Washer 3/4" MED ZN Grade 2 Zinc	8
9	S-7884	Bolt, HHCS 3/4"-10 x 4 Grade 8	8
10	S-234	Hex Nut 3/4"-10 ZN Grade 5, Zinc Plated	8
11	8120011	Drive Shaft TA4, 12" Chain Loop	1
12	8120022	Corner Cover Weldment	1
13	S-845	Flat Washer 5/16" USS SAE YDP Grade 2	40
14	S-1196	Bolt, HHCS 5/16"-18 x 1" ZN Grade 5	20
15	S-1147	Split Lock Washer 5/16" ZN	20
16	S-396	Hex Nut 5/16"-18 YDP Grade 2	20
17	8120004	Square/Round Weldment - 7 Gauge	2
18	S-248	Flat Washer 3/8" 7/16" I.D. 1" O.D. YDP	48
19	S-2071	Bolt, HHCS 3/8"-16 x 1-1/4" ZN Grade 5	24
20	S-1054	Split Lock Washer 3/8" ZN	24
21	S-456	Hex Nut 3/8"-16 YDP Grade 5	24
22	8120170	Cover, Plate for UHMW Bearing Seal	2
N/S	PT1529	Sprocket, 22 Tooth, 3-7/16" B, 81 x HH C-Hub	1
N/S	CE-00972	Key, 7/8" x 7/8" x 6"	1

12" 7 Gauge (40 HP-50 HP) Drive Components (8120144)

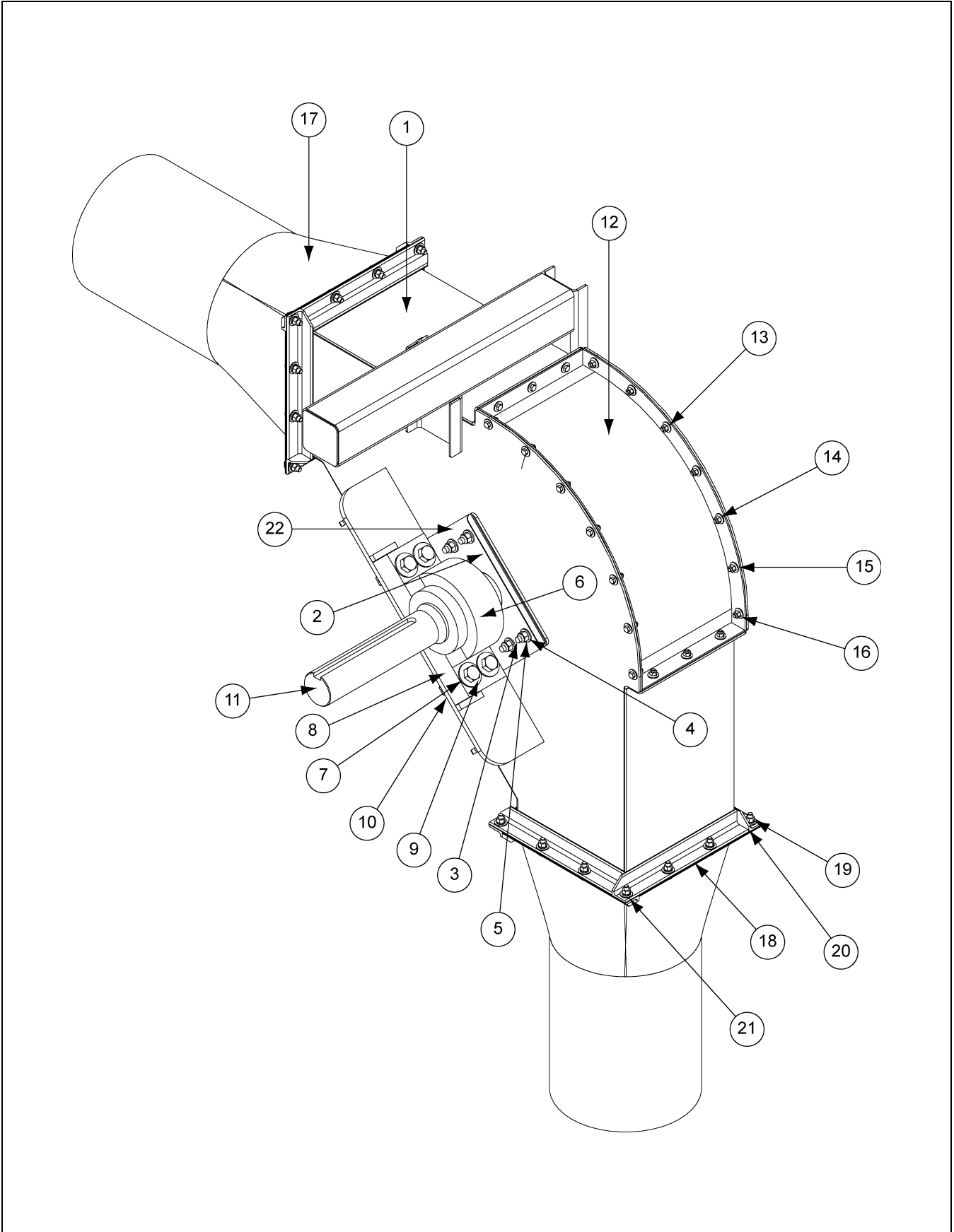

12" 7 Gauge (40 HP-50 HP) Drive Components (8120144) Parts List

Ref #	Part #	Description	Qty
1	8120154	TA5 Drive Corner Weld - 12" Chain Loop	1
2	8120010	Corner Seal UHMW, 12" Chain Loop	2
3	S-8760	Bolt, HHCS 1/2"-13 x 1-1/2" ZN Grade 5	8
4	S-8562	Flat Washer 1/2" GV	8
5	S-8260	Nylock Nut 1/2"-13 ZN Grade 5	8
6	MHC01277	Bearing, Dodge# P4B-S2-307R	2
7	S-866	Flat Washer 3/4" USS ZN Flat Grade 2	16
8	S-233	Split Lock Washer 3/4" MED ZN Grade 2 Zinc	8
9	S-7884	Bolt, HHCS 3/4"-10 x 4 Grade 8	8
10	S-234	Hex Nut 3/4"-10 ZN Grade 5, Zinc Plated	8
11	8120148	Drive Shaft TA4, 12" Chain Loop	1
12	8120022	Corner Cover Weldment	1
13	S-845	Flat Washer 5/16" USS SAE YDP Grade 2	40
14	S-1196	Bolt, HHCS 5/16"-18 x 1" ZN Grade 5	20
15	S-1147	Split Lock Washer 5/16" ZN	20
16	S-396	Hex Nut 5/16"-18 YDP Grade 2	20
17	8120004	Square/Round Weldment - 7 Gauge	2
18	S-248	Flat Washer 3/8" 7/16" I.D. 1" O.D. YDP	48
19	S-1054	Split Lock Washer 3/8" ZN	24
20	S-2071	Bolt, HHCS 3/8"-16 x 1-1/4" ZN Grade 5	24
21	S-456	Hex Nut 3/8"-16 YDP Grade 5	24
22	8120170	Cover, Plate for UHMW Bearing Seal	2
N/S	PT1529	Sprocket, 22 Tooth, 3-7/16" B, 81 x HH C-Hub	1
N/S	CE-00972	Key, 7/8" x 7/8" x 6"	1

12" 7 Gauge (60 HP) Drive Components (8120163)

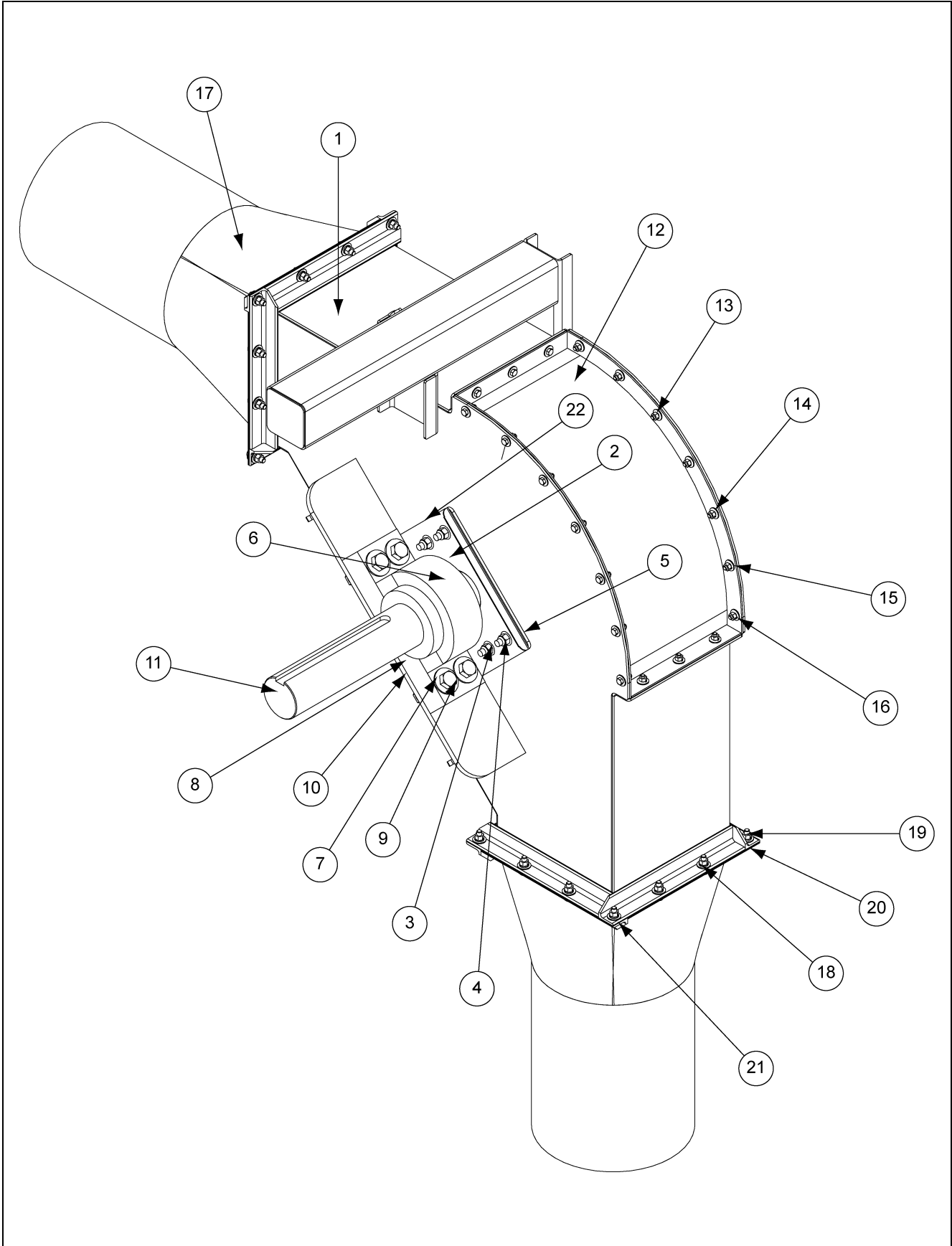

12" 7 Gauge (60 HP) Drive Components (8120163) Parts List

Ref #	Part #	Description	Qty
1	8120164	TA6 Drive Corner Weld - 12" Chain Loop	1
2	8120010	Corner Seal UHMW, 12" Chain Loop	2
3	S-8760	Bolt, HHCS 1/2"-13 x 1-1/2" ZN Grade 5	8
4	S-8562	Flat Washer 1/2" GV	8
5	S-8260	Nylock Nut 1/2"-13 ZN Grade 5	8
6	MHC01277	Bearing, Dodge# P4B-S2-307R	2
7	S-866	Flat Washer 3/4" USS ZN Flat Grade 2	16
8	S-233	Split Lock Washer 3/4" MED ZN Grade 2 Zinc	8
9	S-7884	Bolt, HHCS 3/4"-10 x 4 Grade 8	8
10	S-234	Hex Nut 3/4"-10 ZN Grade 5, Zinc Plated	8
11	8120165	Drive Shaft TA6, 12" Chain Loop	1
12	8120022	Corner Cover Weldment	1
13	S-845	Flat Washer 5/16" USS SAE YDP Grade 2	40
14	S-1196	Bolt, HHCS 5/16"-18 x 1" ZN Grade 5	20
15	S-1147	Split Lock Washer 5/16" ZN	20
16	S-396	Hex Nut 5/16"-18 YDP Grade 2	20
17	8120004	Square/Round Weldment - 7 Gauge	2
18	S-248	Flat Washer 3/8" 7/16" I.D. 1" O.D. YDP	48
19	S-1054	Split Lock Washer 3/8" ZN	24
20	S-2071	Bolt, HHCS 3/8"-16 x 1-1/4" ZN Grade 5	24
21	S-456	Hex Nut 3/8"-16 YDP Grade 5	24
22	8120170	Cover, Plate for UHMW Bearing Seal	2
N/S	PT1529	Sprocket, 22 Tooth, 3-7/16" B, 81 x HH C-Hub	1
N/S	CE-00972	Key, 7/8" x 7/8" x 6"	1

12" 10 Gauge (30 HP) Drive Components (8120175)

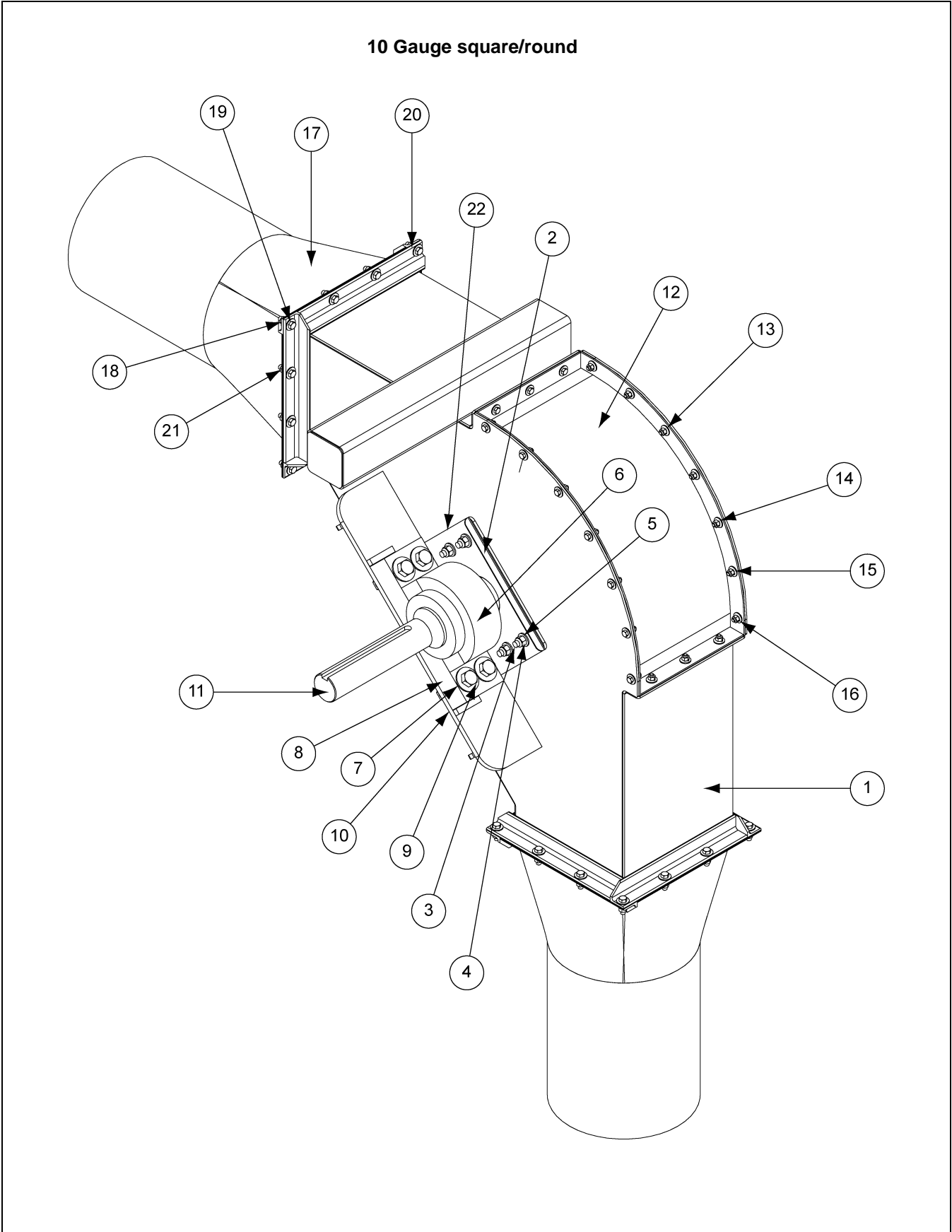

12" 10 Gauge (30 HP) Drive Components (8120175) Parts List

Ref #	Part #	Description	Qty
1	8120027	TA4 Drive Corner Weld - 12" Chain Loop	1
2	8120010	Corner Seal UHMW, 12" Chain Loop	2
3	S-8760	Bolt, HHCS 1/2"-13 x 1-1/2" ZN Grade 5	8
4	S-8562	Flat Washer 1/2" GV	8
5	S-8260	Nylock Nut 1/2"-13 ZN Grade 5	8
6	MHC01277	Bearing, Dodge# P4B-S2-307R	2
7	S-866	Flat Washer 3/4" USS ZN Flat Grade 2	16
8	S-233	Split Lock Washer 3/4" MED ZN Grade 2 Zinc	8
9	S-7884	Bolt, HHCS 3/4"-10 x 4 Grade 8	8
10	S-234	Hex Nut 3/4"-10 ZN Grade 5, Zinc Plated	8
11	8120011	Drive Shaft TA5, 12" Chain Loop	1
12	8120022	Corner Cover Weldment	1
13	S-845	Flat Washer 5/16" USS SAE YDP Grade 2	40
14	S-1196	Bolt, HHCS 5/16"-18 x 1" ZN Grade 5	20
15	S-1147	Split Lock Washer 5/16" ZN	20
16	S-396	Hex Nut 5/16"-18 YDP Grade 2	20
17	8120173	Square/Round Weldment - 10 Gauge	2
18	S-248	Flat Washer 3/8" 7/16" I.D. 1" O.D. YDP	48
19	S-2071	Bolt, HHCS 3/8"-16 x 1-1/4" ZN Grade 5	24
20	S-1054	Split Lock Washer 3/8" ZN	24
21	S-456	Hex Nut 3/8"-16 YDP Grade 5	24
22	8120170	Cover, Plate for UHMW Bearing Seal	2
N/S	PT1529	Sprocket, 22 Tooth, 3-7/16" B, 81 x HH C-Hub	1
N/S	CE-00972	Key, 7/8" x 7/8" x 6"	1

12" 10 Gauge (40 HP-50 HP) Drive Components (8120179)

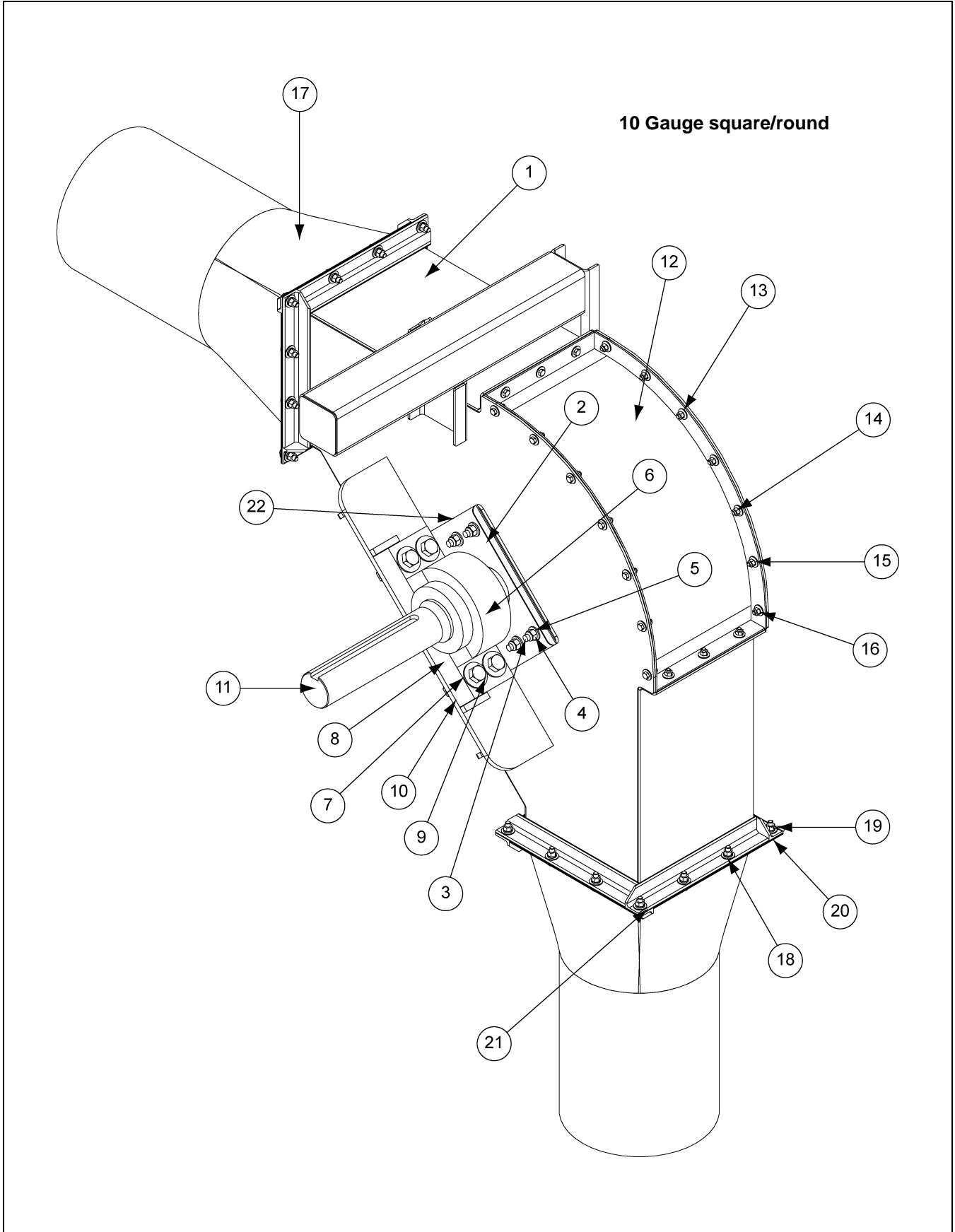

12" 10 Gauge (40 HP-50 HP) Drive Components (8120179) Parts List

Ref #	Part #	Description	Qty
1	8120154	TA5 Drive Corner Weld - 12" Chain Loop	1
2	8120010	Corner Seal UHMW, 12" Chain Loop	2
3	S-8760	Bolt, HHCS 1/2"-13 x 1-1/2" ZN Grade 5	8
4	S-8562	Flat Washer 1/2" GV	8
5	S-8260	Nylock Nut 1/2"-13 ZN Grade 5	8
6	MHC01277	Bearing, Dodge# P4B-S2-307R	2
7	S-866	Flat Washer 3/4" USS ZN Flat Grade 2	16
8	S-233	Split Lock Washer 3/4" MED ZN Grade 2 Zinc	8
9	S-7884	Bolt, HHCS 3/4"-10 x 4 Grade 8	8
10	S-234	Hex Nut 3/4"-10 ZN Grade 5, Zinc Plated	8
11	8120148	Drive Shaft TA5, 12" Chain Loop	1
12	8120022	Corner Cover Weldment	1
13	S-845	Flat Washer 5/16" USS SAE YDP Grade 2	40
14	S-1196	Bolt, HHCS 5/16"-18 x 1" ZN Grade 5	20
15	S-1147	Split Lock Washer 5/16" ZN	20
16	S-396	Hex Nut 5/16"-18 YDP Grade 2	20
17	8120173	Square/Round Weldment - 10 Gauge	2
18	S-248	Flat Washer 3/8" 7/16" I.D. 1" O.D. YDP	48
19	S-1054	Split Lock Washer 3/8" ZN	24
20	S-2071	Bolt, HHCS 3/8"-16 x 1-1/4" ZN Grade 5	24
21	S-456	Hex Nut 3/8"-16 YDP Grade 5	24
22	8120170	Cover, Plate for UHMW Bearing Seal	2
N/S	PT1529	Sprocket, 22 Tooth, 3-7/16" B, 81 x HH C-Hub	1
N/S	CE-00972	Key, 7/8" x 7/8" x 6"	1

12" 10 Gauge (60 HP) Drive Components (8120180)

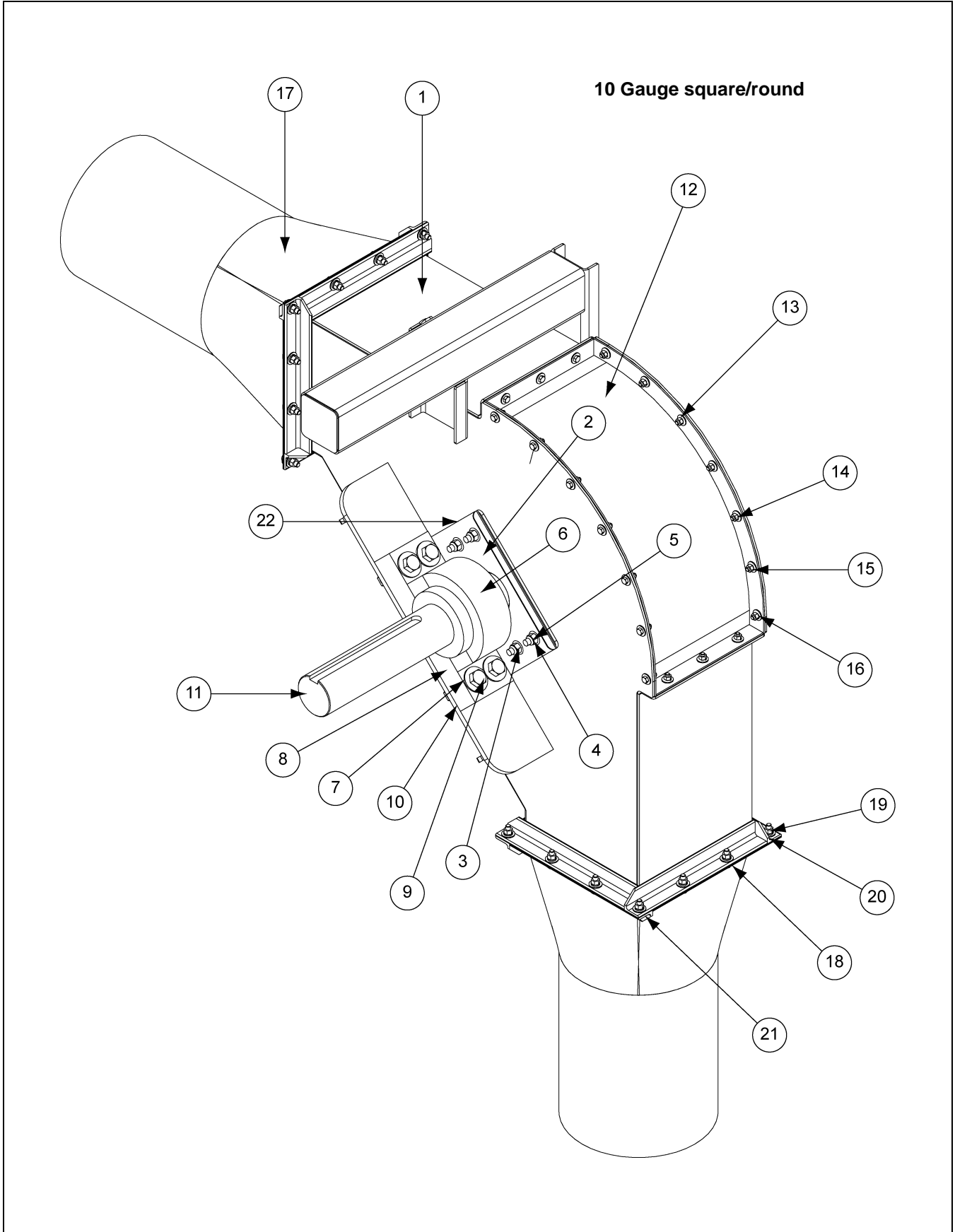

12" 10 Gauge (60 HP) Drive Components (8120180) Parts List

Ref #	Part #	Description	Qty
1	8120164	TA6 Drive Corner Weld - 12" Chain Loop	1
2	8120010	Corner Seal UHMW, 12" Chain Loop	2
3	S-8760	Bolt, HHCS 1/2"-13 x 1-1/2" ZN Grade 5	8
4	S-8562	Flat Washer 1/2" GV	8
5	S-8260	Nylock Nut 1/2"-13 ZN Grade 5	8
6	MHC01277	Bearing, Dodge# P4B-S2-307R	2
7	S-866	Flat Washer 3/4" USS ZN Flat Grade 2	16
8	S-233	Split Lock Washer 3/4" MED ZN Grade 2 Zinc	8
9	S-7884	Bolt, HHCS 3/4"-10 x 4 Grade 8	8
10	S-234	Hex Nut 3/4"-10 ZN Grade 5, Zinc Plated	8
11	8120165	Drive Shaft TA6, 12" Chain Loop	1
12	8120022	Corner Cover Weldment	1
13	S-845	Flat Washer 5/16" USS SAE YDP Grade 2	40
14	S-1196	Bolt, HHCS 5/16"-18 x 1" ZN Grade 5	20
15	S-1147	Split Lock Washer 5/16" ZN	20
16	S-396	Hex Nut 5/16"-18 YDP Grade 2	20
17	8120173	Square/Round Weldment - 10 Gauge	2
18	S-248	Flat Washer 3/8" 7/16" I.D. 1" O.D. YDP	48
19	S-1054	Split Lock Washer 3/8" ZN	24
20	S-2071	Bolt, HHCS 3/8"-16 x 1-1/4" ZN Grade 5	24
21	S-456	Hex Nut 3/8"-16 YDP Grade 5	24
22	8120170	Cover, Plate for UHMW Bearing Seal	2
N/S	PT1529	Sprocket, 22 Tooth, 3-7/16" B, 81 x HH C-Hub	1
N/S	CE-00972	Key, 7/8" x 7/8" x 6"	1

9. Parts List

8" and 10" Inlet Dump Hoppers

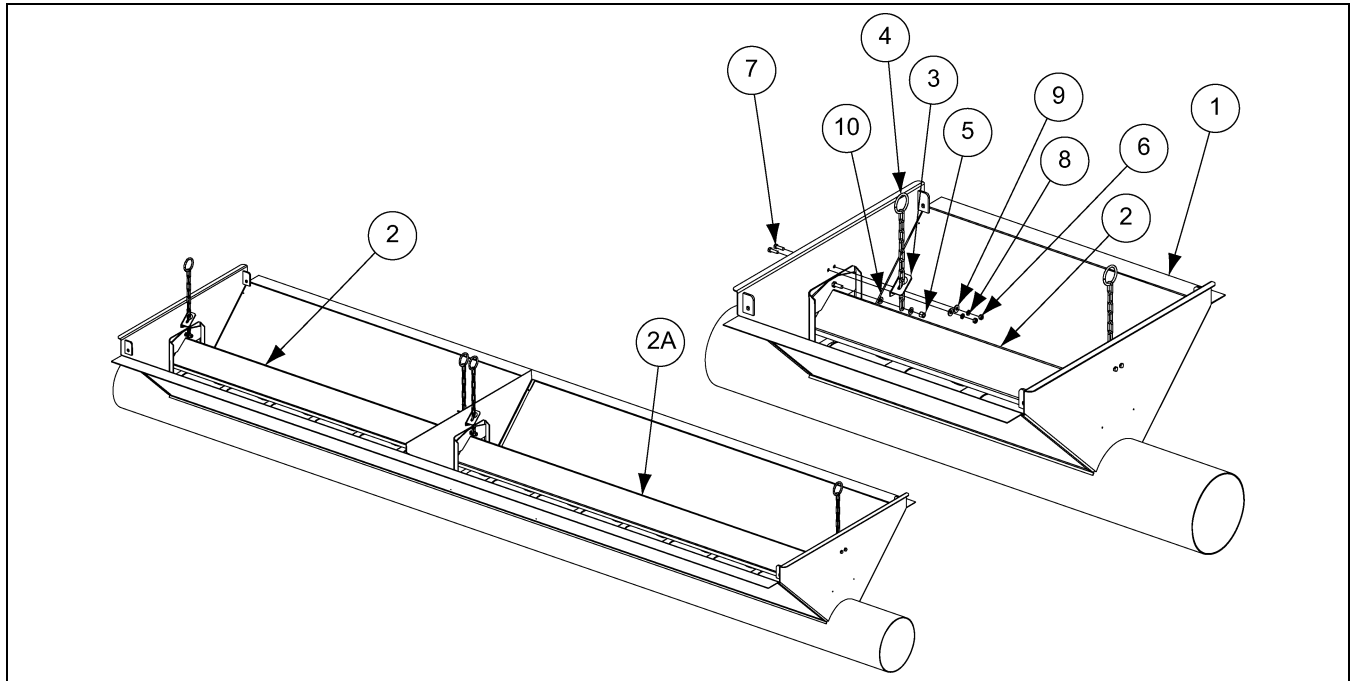

8" and 10" Inlet Dump Hoppers Parts List

Ref #	Part #	Description	Qty
1	8081110	8" Inlet Dump Hopper Weldment (42-1/2" Long)	1
1	8081111	8" Inlet Dump Hopper Weldment (62-1/2" Long)	1
1	8081112	8" Inlet Dump Hopper Weldment (102-1/2" Long)	1
1	8081113	8" Inlet Dump Hopper Weldment (144-1/2" Long)	1
1	8081167	8" Inlet Dump Hopper Weldment (125" Long)	1
1	8101110	10" Inlet Dump Hopper Weldment (42-1/2" Long)	1
1	8101111	10" Inlet Dump Hopper Weldment (62-1/2" Long)	1
1	8101112	10" Inlet Dump Hopper Weldment (102-1/2" Long)	1
1	8101113	10" Inlet Dump Hopper Weldment (144-1/2" Long)	1
2	8081127	Shield-Center, 42" Long 8" Inlet Dump Hopper Weldment	1
2 2A	8081128	Shield-Center, 62" Long 8" Inlet Dump Hopper Weldment	1
2A	8081129	Shield-Center, 81-1/2" Long 8" Inlet Dump Hopper Weldment	1
2	8081130	Shield-Center, 102" Long 8" Inlet Dump Hopper Weldment	1
2	8101127	Shield-Center, 42" Long 10" Inlet Dump Hopper Weldment	1
2	8101128	Shield-Center, 62" Long 10" Inlet Dump Hopper Weldment	1
2A	8101129	Shield-Center, 81-1/2" Long 10" Inlet Dump Hopper Weldment	1
2	8101130	Shield-Center, 102" Long 10" Inlet Dump Hopper Weldment	1
3	8101137	Bracket, Chain Support Inlet Dump Hopper	2
4	8101138	Weldment, Center Shield Chain	2
5	S-7383	Nylock Nut 3/8"-16 ZN Grade 5	2
6	S-396	Hex Nut 5/16"-18 YDP Grade 2	4
7	S-1196	Bolt, HHCS 5/16"-18 x 1" ZN Grade 5	4
8	S-1147	Split Lock Washer 5/16" ZN	4
9	S-1937	Flat Washer 5/16" ZN SAE Grade 2	4
10	S-7409	Flat Washer 3/8" SAE ZN Grade 2	4

12" (7 Gauge) 42-1/2" Inlet Dump Hoppers (8120121)

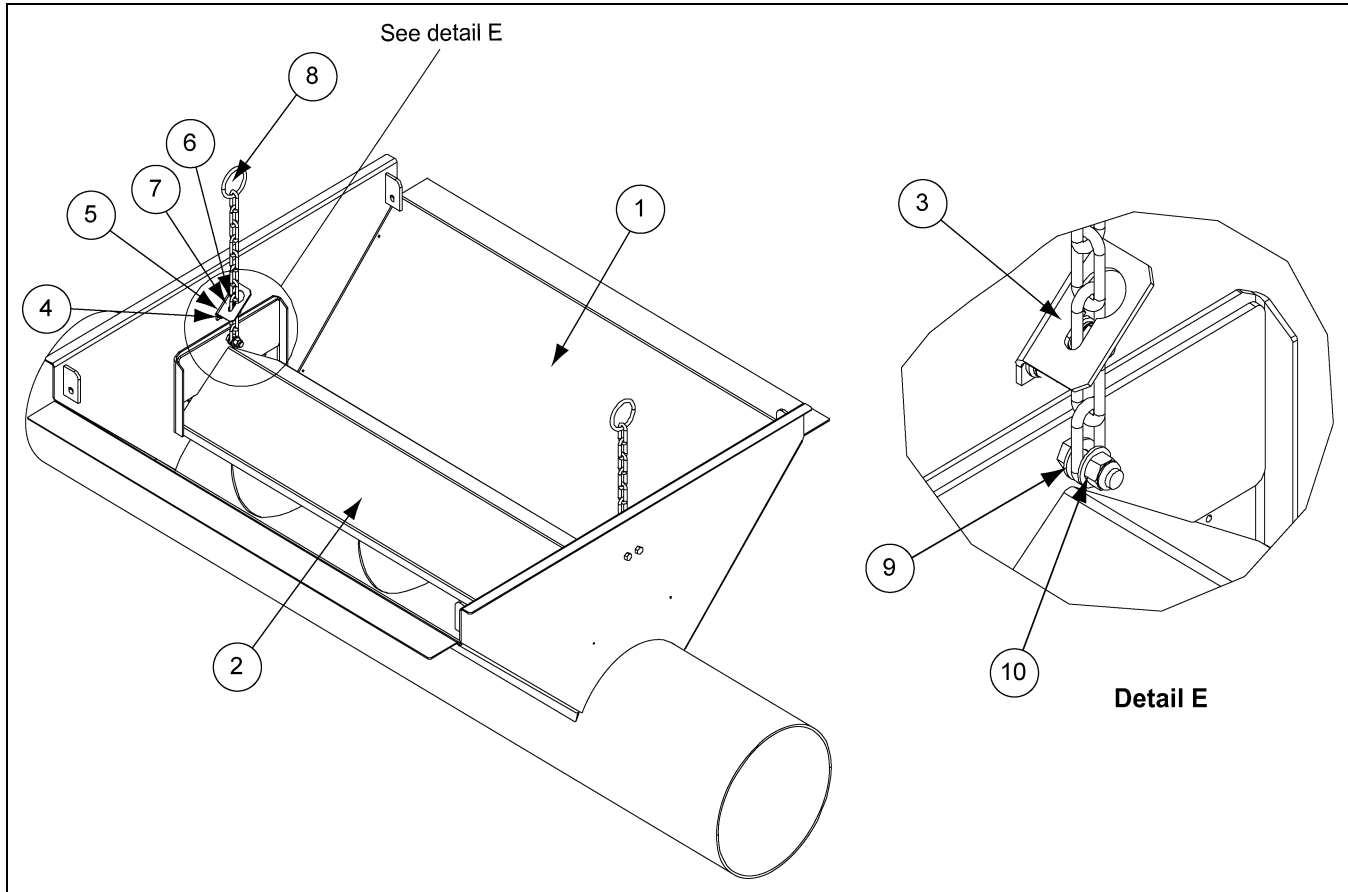

12" (7 Gauge) 42-1/2" Inlet Dump Hoppers (8120121) Parts List

Ref #	Part #	Description	Qty
1	8120112	Dump Hopper Weldment 7 Gauge 42-1/2"	1
2	8120119	Center Shield Weldment 42-1/2"	1
3	8101137	Bracket, Chain Support	2
4	S-1196	Bolt, HHCS 5/16"-18 x 1" ZN Grade 5	4
5	S-1937	Flat Washer 5/16" ZN SAE Grade 2	4
6	S-1147	Split Lock Washer 5/16" ZN	4
7	S-396	Hex Nut 5/16"-18 YDP Grade 2	4
8	8101138	Weldment, Center Shield Chain	2
9	S-7409	Flat Washer 3/8" SAE ZN Grade 2	4
10	S-7383	Nylock Nut 3/8"-16 ZN Grade 5	2

9. Parts List

12" (7 Gauge) 102-1/2" Inlet Dump Hoppers (8120127)

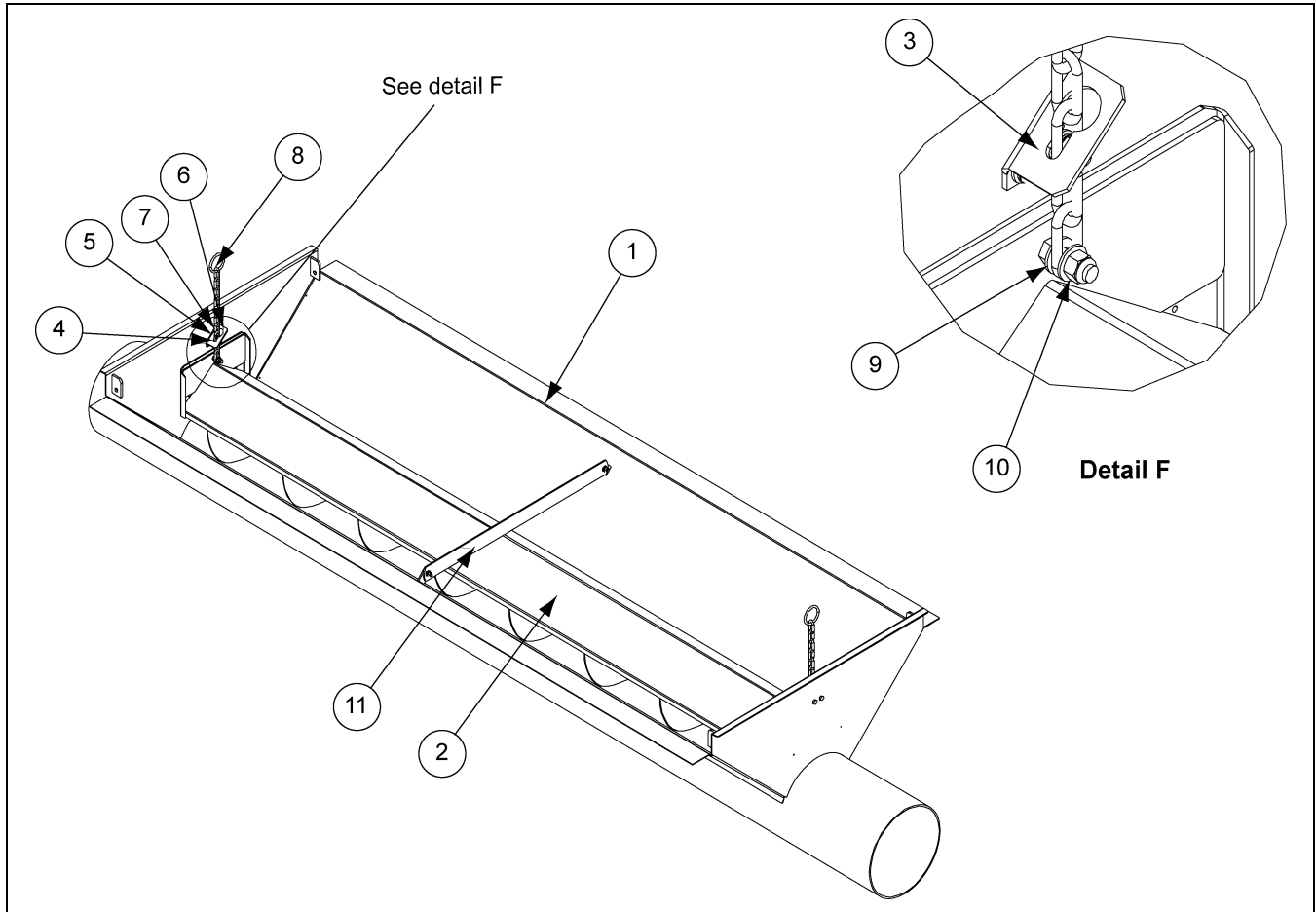

12" (7 Gauge) 102-1/2" Inlet Dump Hoppers (8120127) Parts List

Ref #	Part #	Description	Qty
1	8120125	Dump Hopper Weldment 7 Gauge 102-1/2"	1
2	8120122	Center Shield Weldment 102-1/2"	1
3	8101137	Bracket, Chain Support	2
4	S-1196	Bolt, HHCS 5/16"-18 x 1" ZN Grade 5	6
5	S-1937	Flat Washer 5/16" ZN SAE Grade 2	6
6	S-1147	Split Lock Washer 5/16" ZN	6
7	S-396	Hex Nut 5/16"-18 YDP Grade 2	6
8	8101138	Weldment, Center Shield Chain	2
9	S-7409	Flat Washer 3/8" SAE ZN Grade 2	4
10	S-7383	Nylock Nut 3/8"-16 ZN Grade 5	2
11	8120128	Brace, 12" Dump Hopper Center	1

12" (7 Gauge) 122-1/2" Inlet Dump Hoppers (8120134)

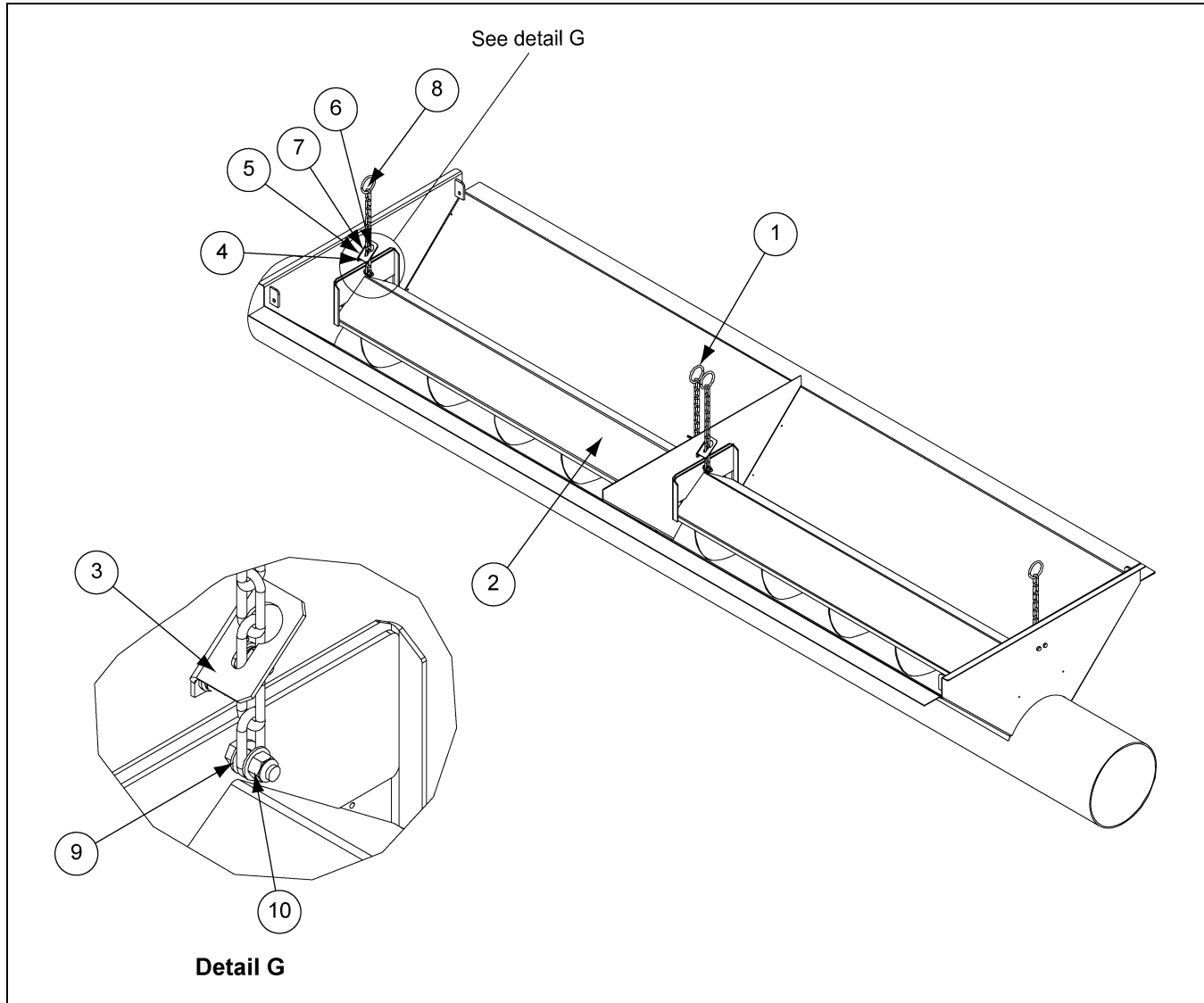

12" (7 Gauge) 122-1/2" Inlet Dump Hoppers (8120134) Parts List

Ref #	Part #	Description	Qty
1	8120132	Dump Hopper Weldment 7 Gauge 122-1/2"	1
2	8120129	Center Shield Weldment 122-1/2"	2
3	8101137	Bracket, Chain Support	4
4	S-1196	Bolt, HHCS 5/16"-18 x 1" ZN Grade 5	6
5	S-1937	Flat Washer 5/16" ZN SAE Grade 2	6
6	S-1147	Split Lock Washer 5/16" ZN	6
7	S-396	Hex Nut 5/16"-18 YDP Grade 2	6
8	8101138	Weldment, Center Shield Chain	4
9	S-7409	Flat Washer 3/8" SAE ZN Grade 2	8
10	S-7383	Nylock Nut 3/8"-16 ZN Grade 5	4

9. Parts List

12" (10 Gauge) 42-1/2" Inlet Dump Hoppers (8120185)

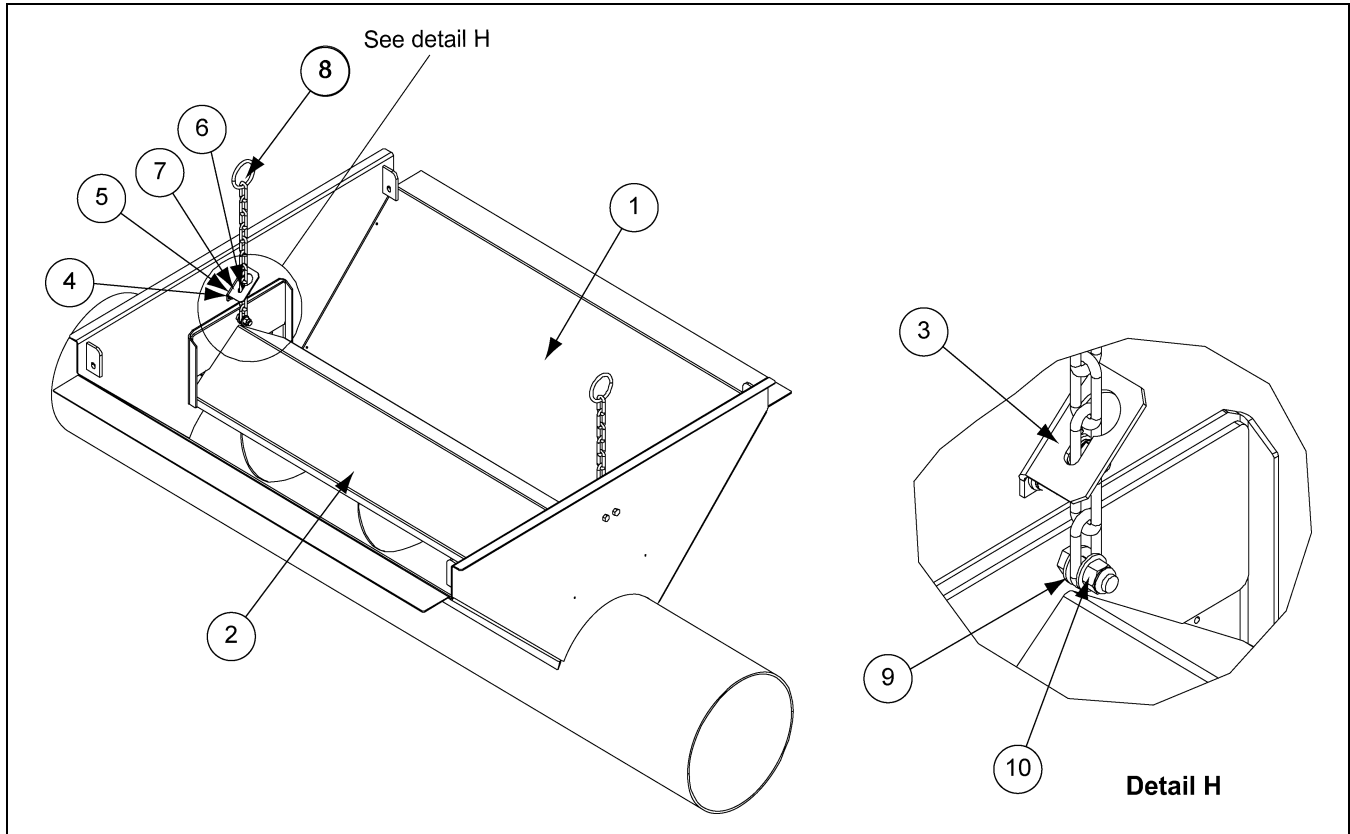

12" (10 Gauge) 42-1/2" Inlet Dump Hoppers (8120185) Parts List

Ref #	Part #	Description	Qty
1	8120188	Dump Hopper Weldment 10 Gauge 42-1/2"	1
2	8120119	Center Shield Weldment 42-1/2"	1
3	8101137	Bracket, Chain Support	2
4	S-1196	Bolt, HHCS 5/16"-18 x 1" ZN Grade 5	4
5	S-1937	Flat Washer 5/16" ZN SAE Grade 2	4
6	S-1147	Split Lock Washer 5/16" ZN	4
7	S-396	Hex Nut 5/16"-18 YDP Grade 2	4
8	8101138	Weldment, Center Shield Chain	2
9	S-7409	Flat Washer 3/8" SAE ZN Grade 2	4
10	S-7383	Nylock Nut 3/8"-16 ZN Grade 5	2

NOTES

9. Parts List

12" (10 Gauge) 102-1/2" Inlet Dump Hoppers (8120186)

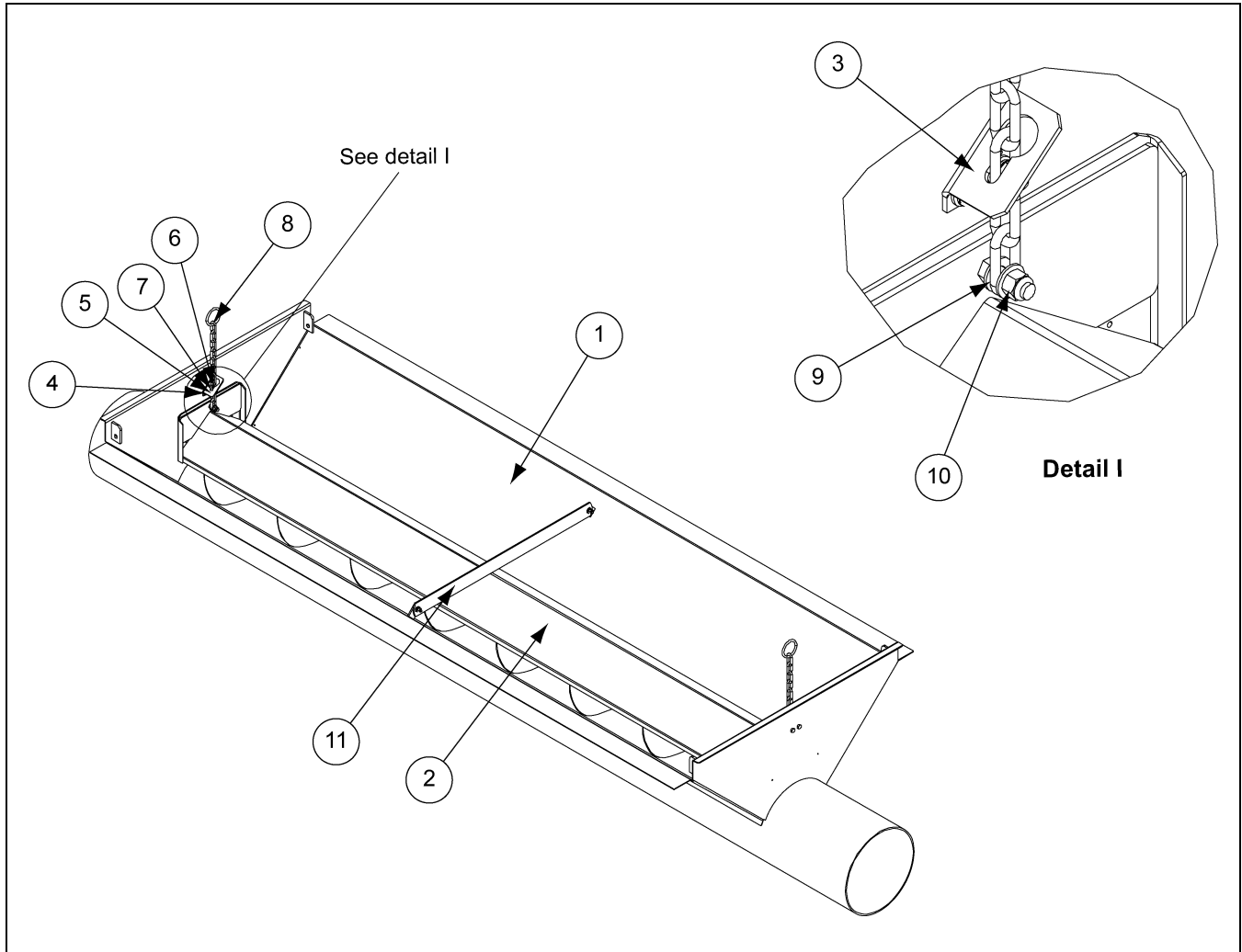

12" (10 Gauge) 102-1/2" Inlet Dump Hoppers (8120186) Parts List

Ref #	Part #	Description	Qty
1	8120189	Dump Hopper Weldment 10 Gauge 102-1/2"	1
2	8120122	Center Shield Weldment 102-1/2"	1
3	8101137	Bracket, Chain Support	2
4	S-1196	Bolt, HHCS 5/16"-18 x 1" ZN Grade 5	6
5	S-1937	Flat Washer 5/16" ZN SAE Grade 2	6
6	S-1147	Split Lock Washer 5/16" ZN	6
7	S-396	Hex Nut 5/16"-18 YDP Grade 2	6
8	8101138	Weldment, Center Shield Chain	2
9	S-7409	Flat Washer 3/8" SAE ZN Grade 2	4
10	S-7383	Nylock Nut 3/8"-16 ZN Grade 5	2
11	8120128	Brace, 12" Dump Hopper Center	1

12" (10 Gauge) 122-1/2" Inlet Dump Hoppers (8120187)

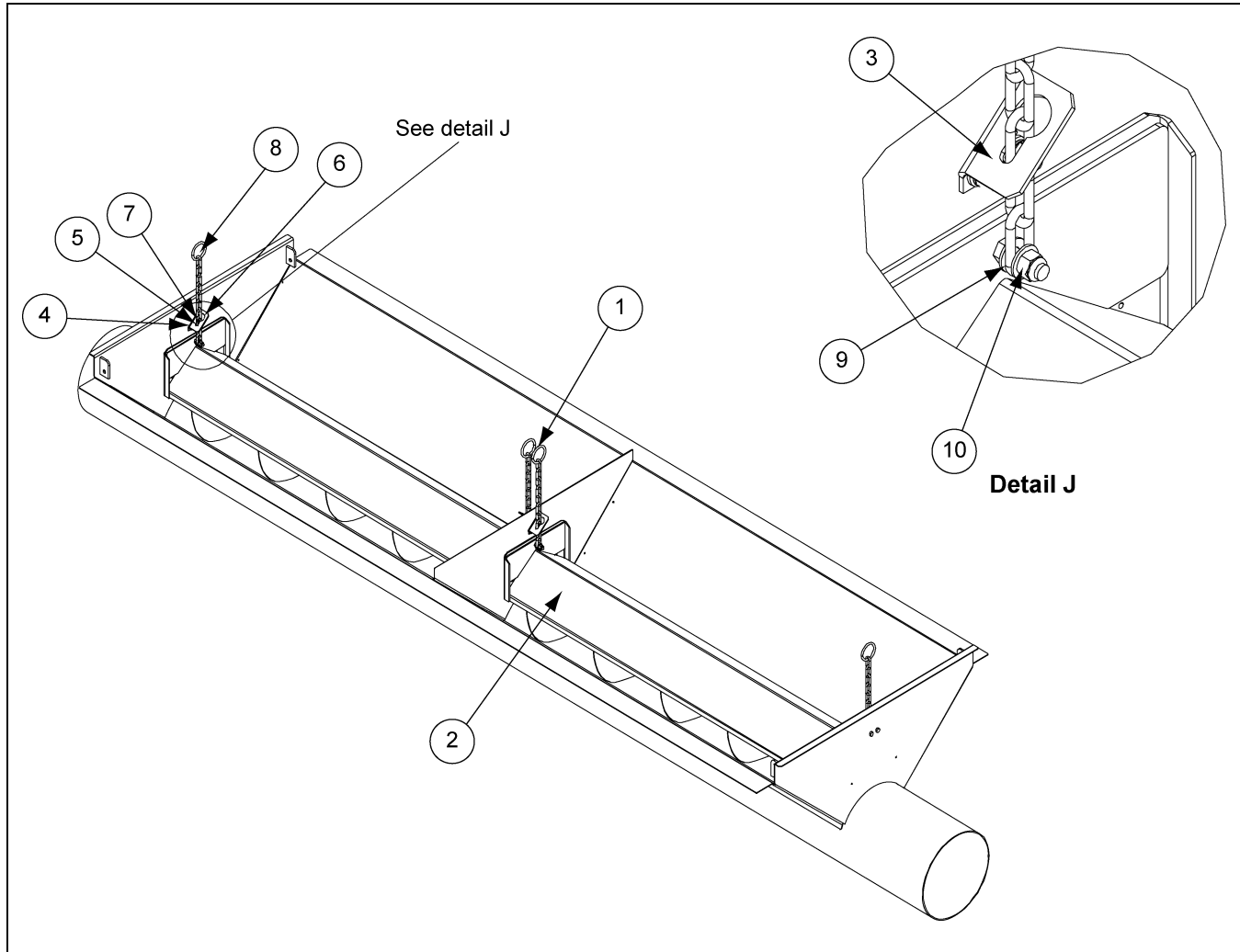

12" (10 Gauge) 122-1/2" Inlet Dump Hoppers (8120187) Parts List

Ref #	Part #	Description	Qty
1	8120190	Dump Hopper Weldment 10 Gauge 122-1/2"	1
2	8120129	Center Shield Weldment 122-1/2"	2
3	8101137	Bracket, Chain Support	4
4	S-1196	Bolt, HHCS 5/16"-18 x 1" ZN Grade 5	6
5	S-1937	Flat Washer 5/16" ZN SAE Grade 2	6
6	S-1147	Split Lock Washer 5/16" ZN	6
7	S-396	Hex Nut 5/16"-18 YDP Grade 2	6
8	8101138	Weldment, Center Shield Chain	4
9	S-7409	Flat Washer 3/8" SAE ZN Grade 2	8
10	S-7383	Nylock Nut 3/8"-16 ZN Grade 5	4

8" and 10" Standard Corner

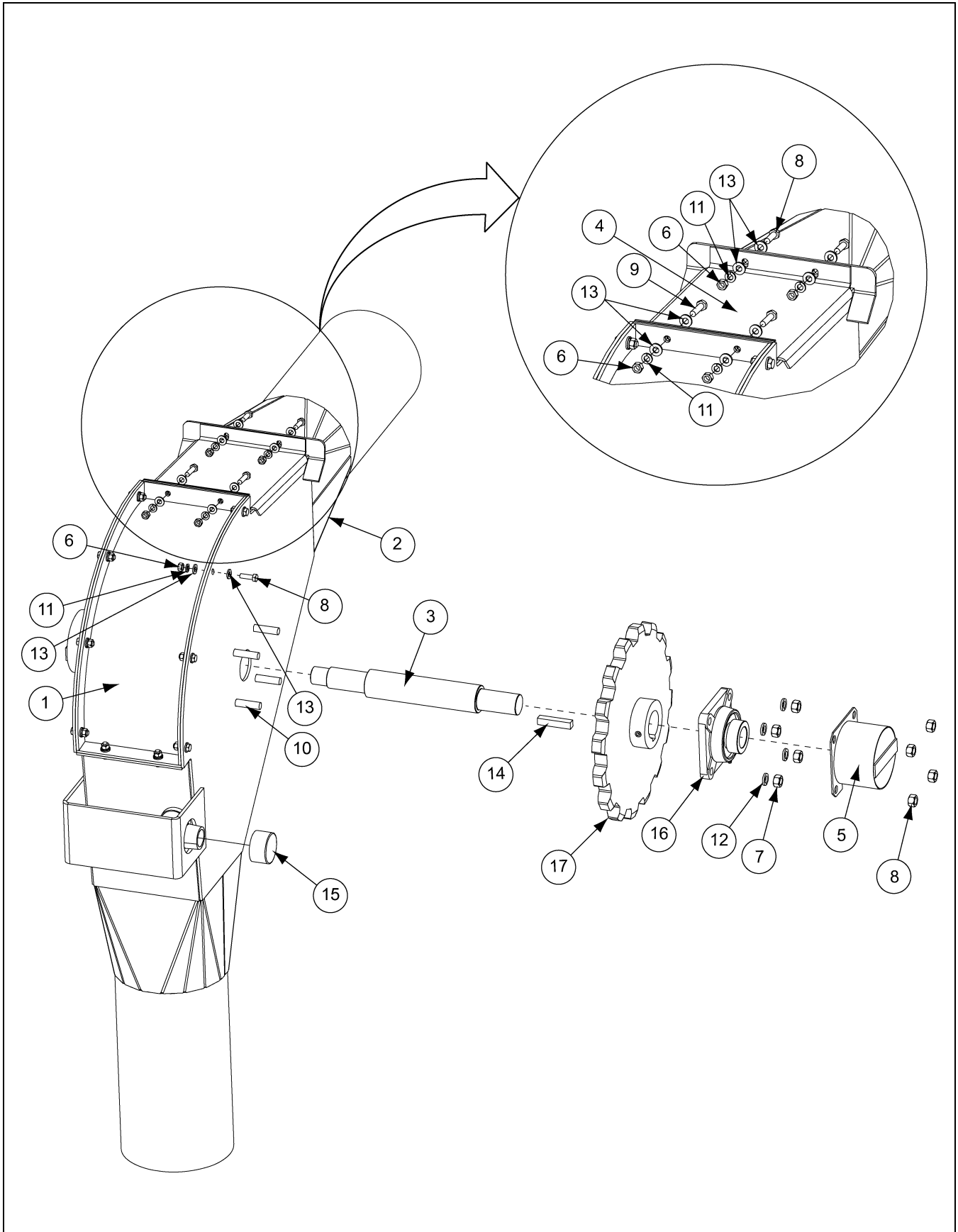

8" and 10" Standard Corner Parts List

Ref #	Part #	Description	Qty
1	8081009	Weld, 8" Drive/Stand Corner Inspection Door	1
1	8101009	Door-Inspection, Weldment	1
2	8081022	8" Corner-Standard, 8" Weldment Hot Dipped 8081023	1
2	8101022	10" Corner-Standard, 10" Weldment Hot Dipped 8101023	1
3	8081029	8" Shaft-Corner, 8" Standard/Inspection Corner	1
3	8101029	10" Shaft-Corner, 10" Standard/Inspection Corner	1
4	8081032	Access Door, 8" Standard Corner	1
4	8101032	Access Door, 10" Standard Corner	1
5	8081196	8" Cover-Bearing Shield Zinc Plated 8081197	2
5	8101196	10" Cover-Bearing Shield Zinc Plated 8101197	2
6		Hex Nut, 5/16"-18 UNC Finished, Plated, Grade 2	14
7		Hex Nut, 1/2"-13 UNC Finished, Plated, Grade 2	16
8		Hex Bolt, Standard Third-Grade 5 5/16"-18 UNC x 1", Plated	12
9		Hex Bolt, Standard Third-Grade 5 5/16"-18 UNC x 1-1/4", Plated	2
10		Hex Bolt, Standard Third-Grade 5 1/2"-13 UNC x 2, Plated	8
11		Lock Washer, Regular 5/16", Plated	14
12		Lock Washer, Regular 1/2", Plated	8
13		Flat Washer, SAE 5/16", Plated	28
14		Key-Square, 1/2" x 2-1/2"	1
15		Fit-Cap, Pipe 1-1/2", (SCH 40)	1
16	PT0145	8" Bearing with Housing, 1-1/2" ECC LK, Wide, RL, CYL, 4H	2
16	PT0144	10" Bearing with Housing, 2" ECC LK, Wide, RL, CYL, 4H	2
17	PT1093	8" Sprocket (Hub Type) 16 Tooth, 2" I.D., 81XH	1
17	PT1086	Sprocket, (Hub Type) 3" I.D.	1

12" (7 Gauge) Standard Corner (8120031)

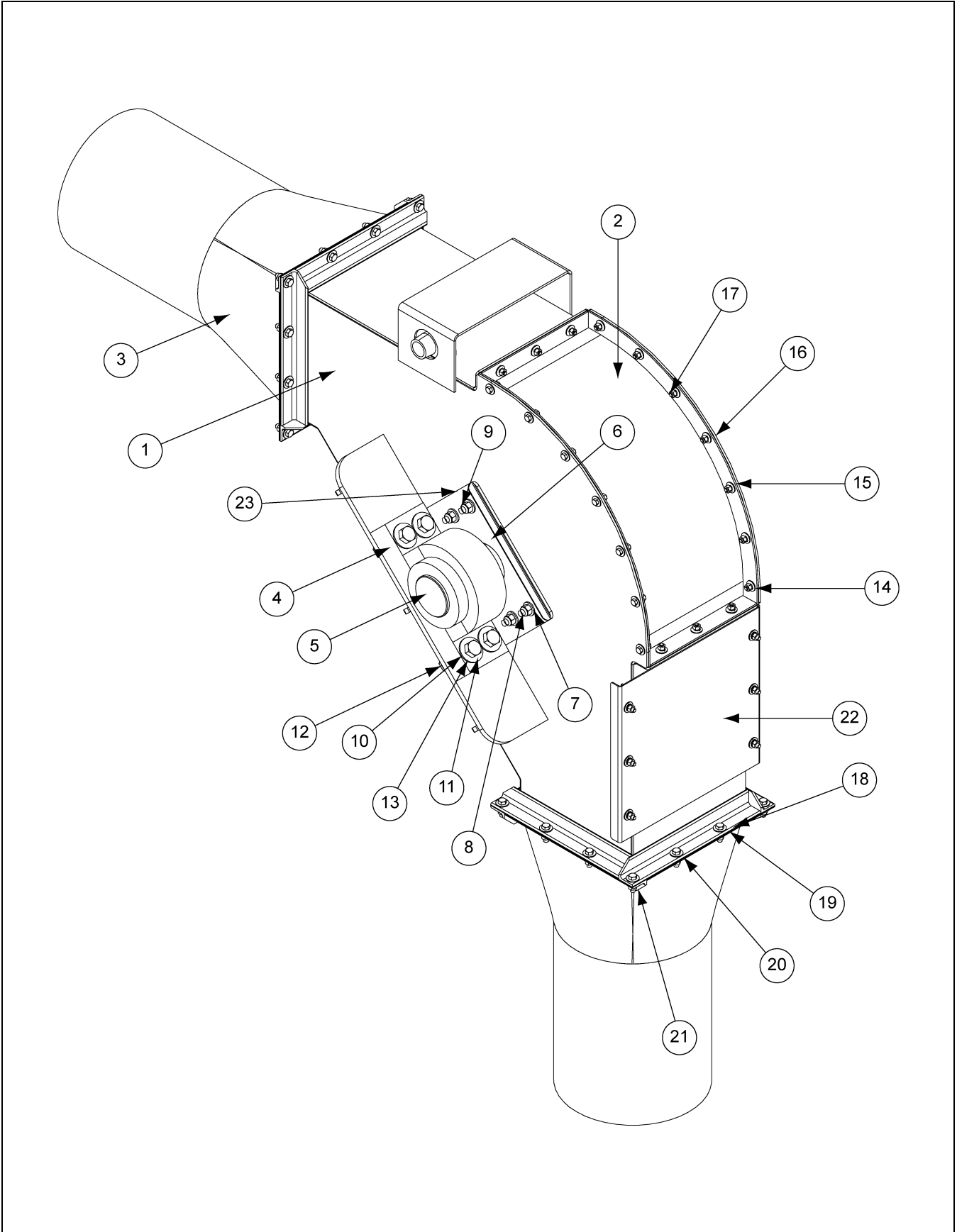

12" (7 Gauge) Standard Corner (8120031) Parts List

Ref #	Part #	Description	Qty
1	8120030	Standard Corner Weldment	1
2	8120022	Corner Cover Weldment	1
3	8120004	Square/Round Weldment - 7 Gauge	2
4	MHC01277	Bearing, Dodge# P4B-S2-307R	2
5	8120032	Shaft, Standard Corner	1
6	8120010	Corner Seal UHMW, 12" Chain Loop	2
7	S-8760	Bolt, HHCS 1/2"-13 x 1-1/2" ZN Grade 5	8
8	S-8562	Flat Washer 1/2 GV	8
9	S-8260	Nylock Nut 1/2"-13 ZN Grade 5	8
10	S-866	Flat Washer 3/4" USS ZN Flat Grade 2	16
11	S-7884	Bolt, HHCS 3/4"-10 x 4 Grade 8	8
12	S-233	Split Lock Washer 3/4" Med ZN Grade 2	8
13	S-234	Hex Nut 3/4"-10 ZN Grade 5, Zinc Plated	8
14	S-845	Flat Washer 5/16" USS SAE YDP Grade 2	52
15	S-1147	Split Lock Washer 5/16" ZN	26
16	S-1196	Bolt, HHCS 5/16"-18 x 1" ZN Grade 5	26
17	S-396	Hex Nut 5/16"-18 YDP Grade 2	26
18	S-248	Flat Washer 3/8" 7/16" I.D. 1" O.D. YDP	48
19	S-2071	Bolt, HHCS 3/8"-16 x 1-1/4" ZN Grade 5	24
20	S-1054	Split Lock Washer 3/8" ZN	24
21	S-456	Hex Nut 3/8"-16 YDP Grade 5	24
22	8120099	Door, Standard Corner Inspection	1
23	8120170	Cover, Plate for UHMW Bearing Seal	2
N/S	PT1529	Sprocket, 22 Tooth, 3-7/16" B, 81 x HH C-Hub	1
N/S	CE-00972	Key, 7/8" x 7/8" x 6"	1
N/S	S-2052	Strip, Foam 1/8" Thick x 1/2" Wide	4.083'

12" (10 Gauge) Standard Corner (8120176)

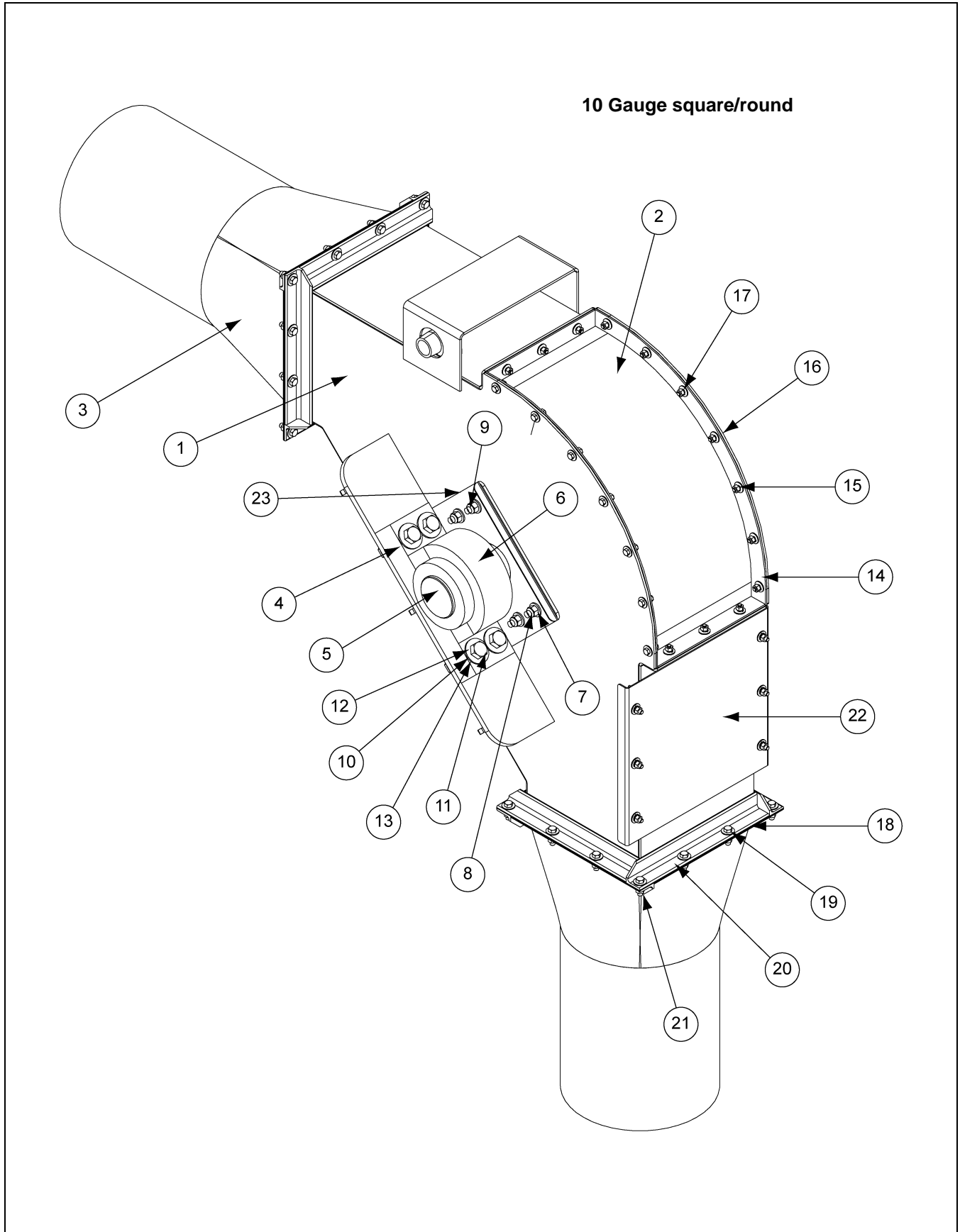

12" (10 Gauge) Standard Corner (8120176) Parts List

Ref #	Part #	Description	Qty
1	8120030	Standard Corner Weldment	1
2	8120022	Corner Cover Weldment	1
3	8120173	Square/Round Weldment - 10 Gauge	2
4	MHC01277	Bearing, Dodge# P4B-S2-307R	2
5	8120032	Shaft, Standard Corner	1
6	8120010	Corner Seal UHMW, 12" Chain Loop	2
7	S-8760	Bolt, HHCS 1/2"-13 x 1-1/2" ZN Grade 5	8
8	S-8562	Flat Washer 1/2 GV	8
9	S-8260	Nylock Nut 1/2"-13 ZN Grade 5	8
10	S-866	Flat Washer 3/4" USS ZN Flat Grade 2	16
11	S-7884	Bolt, HHCS 3/4"-10 x 4 Grade 8	8
12	S-233	Split Lock Washer 3/4" Med ZN Grade 2	8
13	S-234	Hex Nut 3/4"-10 ZN Grade 5, Zinc Plated	8
14	S-845	Flat Washer 5/16" USS SAE YDP Grade 2	52
15	S-1147	Split Lock Washer 5/16" ZN	26
16	S-1196	Bolt, HHCS 5/16"-18 x 1" ZN Grade 5	26
17	S-396	Hex Nut 5/16"-18 YDP Grade 2	26
18	S-248	Flat Washer 3/8" 7/16" I.D. 1" O.D. YDP	48
19	S-2071	Bolt, HHCS 3/8"-16 x 1-1/4" ZN Grade 5	24
20	S-1054	Split Lock Washer 3/8" ZN	24
21	S-456	Hex Nut 3/8"-16 YDP Grade 5	24
22	8120099	Door, Standard Corner Inspection	1
23	8120170	Cover, Plate for UHMW Bearing Seal	2
N/S	PT1529	Sprocket, 22 Tooth, 3-7/16" B, 81 x HH C-Hub	1
N/S	CE-00972	Key, 7/8" x 7/8" x 6"	1
N/S	S-2052	Strip, Foam 1/8" Thick x 1/2" Wide	4.083'

8" and 10" Inspection Corner

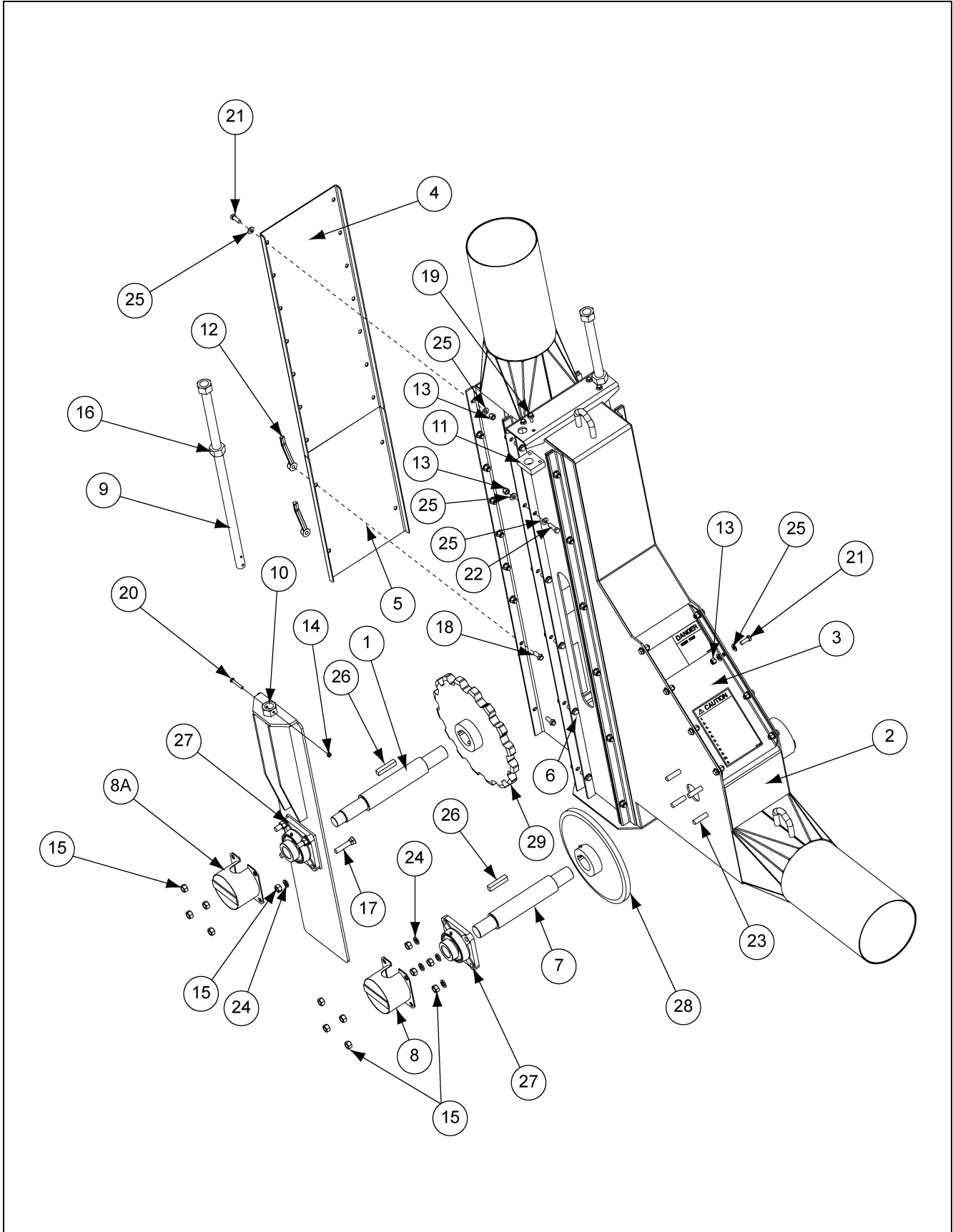

8" and 10" Inspection Corner Parts List

Ref #	Part #	Description	Qty
1	8081029	8" Shaft-Corner, 8" Standard/Inspection Corner	1
1	8101029	10" Shaft-Corner, 10" Standard/Inspection Corner	1
2	8081049	Corner-Inspection, 8" Weldment Hot Dipped 8081050	1
2	8101049	Corner-Inspection, 10" Weldment Hot Dipped 8081050	1
3	8081063	Door-Inspection, 45° 8" Inspection Corner	1
3	8101063	Door-Inspection, 45° 10" Inspection Corner	1
4	8081065	Door-Inspection, Long 8" Inspection Corner	1
4	8101065	Door-Inspection, Long 10" Inspection Corner	1
5	8081067	Door-Inspection, Short 8" Inspection Corner	1
5	8101067	Door-Inspection, Short 10" Inspection Corner	1
6	8081078	Slide Plate, 56" Long (8") Hot Dipped 8081079	8
6	8101078	Slide Plate, 57" Long (10") Hot Dipped 8101079	8
7	8081080	Shaft-Inspection Corner, 8" Inspection Corner	1
7	8101080	Shaft-Inspection Corner, 10" Inspection Corner	1
8	8081196 (for PT0145)	8" Cover-Bearing Shield Zinc Plated 8081197	4
8a	8101196 (for PT0144)	10" Cover-Bearing Shield Zinc Plated 8101197	2
9	8101075	Take Up Screw-Weldment 6", 8" and 10" Inspection Corner	2
10	8101077	Take Up Screw-Nut 6", 8", 10" Inspection Corner	4
11	8101202	Take Up Screw - Block	2
12	1FH0582	Nut Handle, Iron 3/8"-16, Zinc Plated	4
13		Lock Nut, 3/8"-16 UNC Nylon Lock, Plated, Grade 2	46
14		Lock Nut, 1/4"-20 UNC Two-way, Plated, Grade 2	4
15		Hex Nut, 1/2"-13 UNC Finished, Plated, Grade 2	32
16		Hex Nut, 1-8 UNC Finished, Plated, Grade 2	2
17	8" System	Bolt-Plow, #3 Head, RD, CSK 1/2"-13 UNC x 2-1/2", SQ Neck	8
17	10" System	Bolt-Plow, #3 Head, RD, CSK 5/8"-11 UNC x 3", SQ Neck	8
18		Screw-Flange Whiz Lock 3/8"-16 UNC x 1, Plated	4
19		Screw-Flange Whiz Lock 5/16"-18 UNC x 3/4", Plated	4
20		Hex Bolt, Standard Third-Grade 5 1/4"-20 UNC x 1-3/4", Plated	4
21		Hex Bolt, Standard Third-Grade 5 3/8"-16 UNC x 1, Plated	22
22		Hex Bolt, Standard Third-Grade 5 3/8"-16 UNC x 1-1/4", Plated	24
23		Hex Bolt, Standard Third-Grade 5 1/2"-13 UNC x 2, Plated	8
24		Lock Washer, Regular 1/2", Plated	16
25		Flat Washer, Standard 3/8", Plated	92
26		Key-Square, 1/2" x 2-1/2"	2
27	PT0145	8" Bearing with Housing, 1-1/2" ECC LK, Wide, RL, CYL, 4H	4
27	PT0144	10" Bearing with Housing, 2" ECC LK, Wide, RL, CYL, 4H	2
28	PT1087	Idler Wheel - 8" and 10" Inspection Corner	1
29	PT1093	8" Sprocket (Hub Type) 16 Tooth, 2" I.D., 81XH	1
29	PT1086	Sprocket-(Hub Type) 16 Tooth, 3" I.D., 81XH	1

12" (7 Gauge) Inspection Corner (8120051)

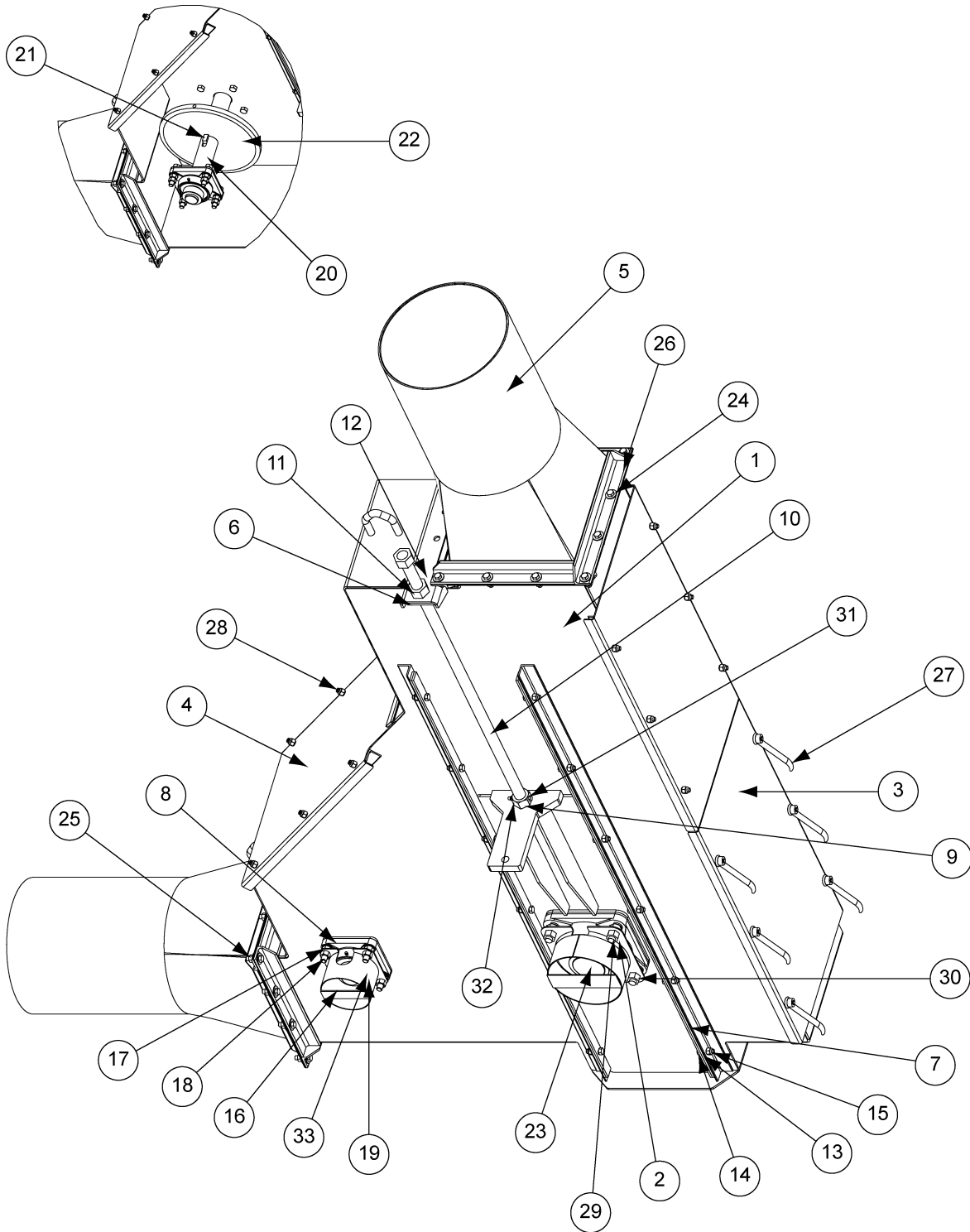

NOTE: Drill 1/4" hole through the nut (S-240) and threaded rod and fasten with bolt (S-8971) and nut (S-4310). Typical four (4) places.

12" (7 Gauge) Inspection Corner (8120051) Parts List

Ref #	Part #	Description	Qty
1	8120034	Inspection Corner Weldment	1
2	8120062	GTU Slide Assembly	2
3	8120050	Sprocket Cover - Inspection Corner	2
4	8120048	Idler Cover	1
5	8120004	Square/Round Weldment - 7 Gauge	2
6	8101202	Take Up Screw - Block	2
7	8081078	Slide Plate 56" Long (8") Hot Dipped 8081079	8
8	PT0145	8" Bearing with Housing, 1-1/2" ECC LK, Wide, RL, CYL, 4H	2
9	8101077	Take Up Screw-Nut 6", 8", 10" Inspection Corner	4
10	8120052	Standard Take Up Screw - Weldment	2
11	S-240	Hex Nut 1"-8" ZN Grade 5	2
12	S-6606	Flange Bolt 5/16"-18 x 3/4" ZN Grade 5	4
13	S-7409	Flat Washer 3/8" SAE ZN Grade 2	88
14	S-2071	Bolt, HHCS 3/8"-16 x 1-1/4" ZN Grade 5	48
15	S-7383	Nylock Nut 3/8"-16 ZN Grade 5	40
16	S-6500	Bolt, HHCS 1/2"-13 x 2-1/2" ZN Grade 5	8
17	S-236	1/2" Lock Washer	8
18	S-3729	Hex Nut 1/2"-13 YDP Grade 5	16
19	8081196	8" Cover-Bearing Shield Zinc Plated 8081197	2
20	8120054	Idler Shaft - Inspection Corner	1
21	S-9167	Key - Square, 1/2" x 1/2" x 2-1/2"	1
22	8120242	Idler Wheel	1
23	8120055	Shaft - Inspection Corner	1
24	S-248	Flat Washer 3/8" 7/16" I.D. 1" O.D. YDP	48
25	S-1054	Split Lock Washer 3/8" ZN	24
26	S-456	Hex Nut 3/8"-16 YDP Grade 5	24
27	BC-00003	Handle, Easy Grip 3/8"-16	6
28	S-7469	Bolt, HHCS 3/8"-16 x 1" ZN Grade 5	22
29	8120056	Bearing Cover Assembly	2
30	S-4110	Hex Nut 5/8"-11 ZN Grade 5	8
31	S-9377	Bolt, 1/4"-20 x 2 ZN Grade 8	4
32	S-7025	Hex Nut 1/4"-20 Nylon	4
33	8101305	UHMW Bearing Seal	2
N/S	MHC01742	Sprocket C Hub, 22 Tooth, 2.609" Pitch	1
N/S	CE-00972	Key, 7/8" x 7/8" x 6"	1
N/S	S-2052	Strip, Foam 1/8" Thick x 1/2" Wide	13.458'

12" (10 Gauge) Inspection Corner (8120177)

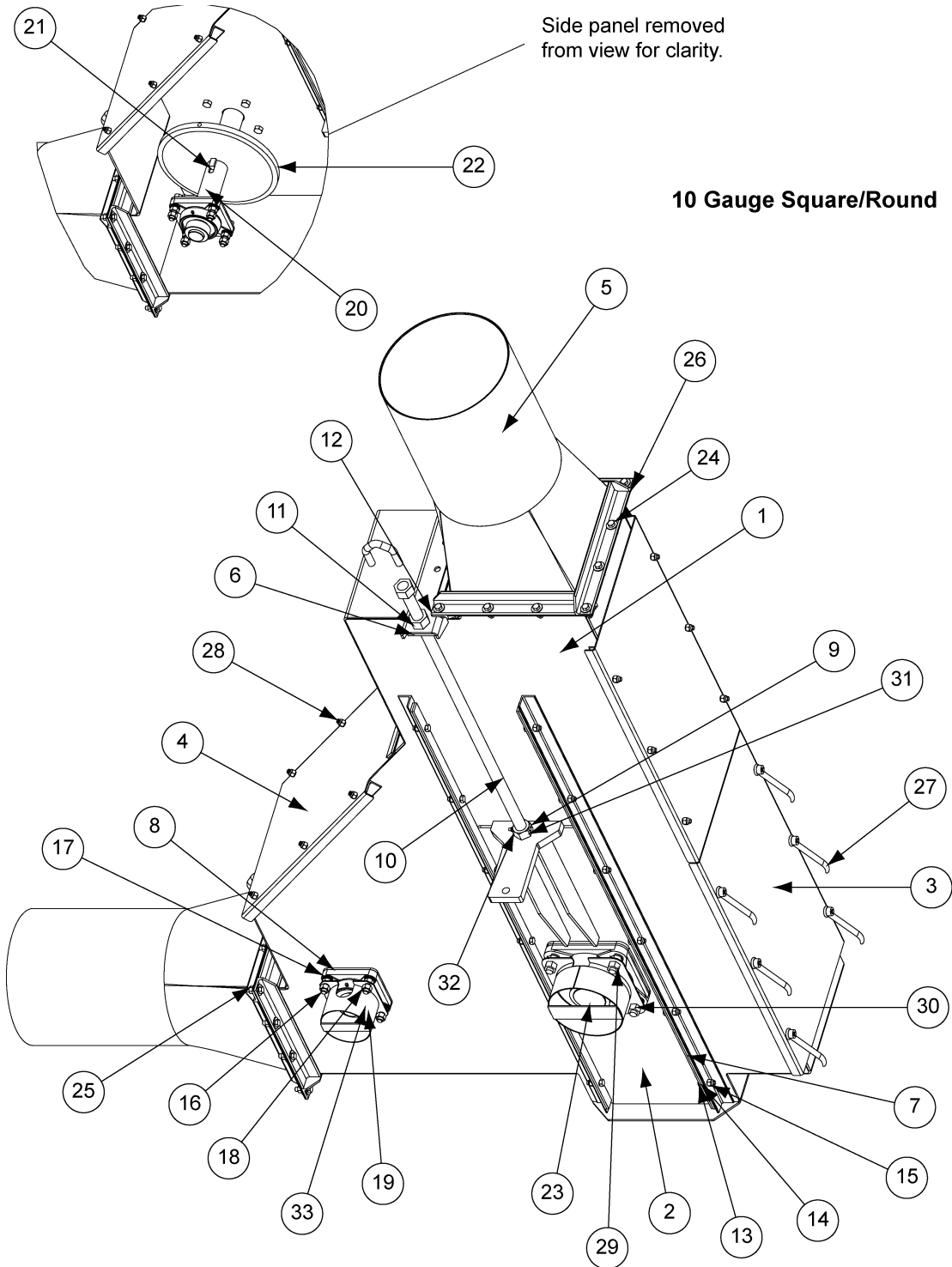

NOTE: Drill 1/4" hole through the nut (S-240) and threaded rod and fasten with bolt (S-8971) and nut (S-4310). Typical four (4) places.

12" (10 Gauge) Inspection Corner (8120177) Parts List

Ref #	Part #	Description	Qty
1	8120034	Inspection Corner Weldment	1
2	8120062	GTU Slide Assembly	2
3	8120050	Sprocket Cover - Inspection Corner	2
4	8120048	Idler Cover	1
5	8120173	Square/Round Weldment - 10 Gauge	2
6	8101202	Take Up Screw - Block	2
7	8081078	Slide Plate 56" Long (8") Hot Dipped 8081079	8
8	PT0145	8" Bearing with Housing, 1-1/2" ECC LK, Wide, RL, CYL, 4H	2
9	8101077	Take Up Screw-Nut 6", 8", 10" Inspection Corner	4
10	8120052	Standard Take Up Screw - Weldment	2
11	S-240	Hex Nut 1"-8" ZN Grade 5	2
12	S-6606	Flange Bolt 5/16"-18 x 3/4" ZN Grade 5	4
13	S-7409	Flat Washer 3/8" SAE ZN Grade 2	88
14	S-2071	Bolt, HHCS 3/8"-16 x 1-1/4" ZN Grade 5	48
15	S-7383	Nylock Nut 3/8"-16 ZN Grade 5	40
16	S-6500	Bolt, HHCS 1/2"-13 x 2-1/2" ZN Grade 5	8
17	S-236	1/2" Lock Washer	8
18	S-3729	Hex Nut 1/2"-13 YDP Grade 5	16
19	8081196	8" Cover-Bearing Shield Zinc Plated 8081197	2
20	8120054	Idler Shaft - Inspection Corner	1
21	S-9167	Key - Square, 1/2" x 1/2" x 2-1/2"	1
22	8120242	Idler Wheel	1
23	8120055	Shaft - Inspection Corner	1
24	S-248	Flat Washer 3/8" 7/16" I.D. 1" O.D. YDP	48
25	S-1054	Split Lock Washer 3/8" ZN	24
26	S-456	Hex Nut 3/8"-16 YDP Grade 5	24
27	BC-00003	Handle, Easy Grip 3/8"-16	6
28	S-7469	Bolt HHCS 3/8"-16 x 1" ZN Grade 5	22
29	8120056	Bearing Cover Assembly	2
30	S-4110	Hex Nut 5/8"-11 ZN Grade 5	8
31	S-9377	Bolt, 1/4"-20 x 2 ZN Grade 8	4
32	S-7025	Hex Nut 1/4"-20 Nylon	4
33	8101305	UHMW Bearing Seal	2
N/S	MHC01742	Sprocket C Hub, 22 Tooth, 2.609" Pitch	1
N/S	CE-00972	Key, 7/8" x 7/8" x 6"	1
N/S	S-2052	Strip, Foam 1/8" Thick x 1/2" Wide	13.458'
N/S	DC-1741	Decal, Notice	1
N/S	DC-1379	Decal, Notice 5-1/8" x 7-3/8"	2
N/S	8107001	Decal, Danger	2

Chain Loop Torque Plate Assembly

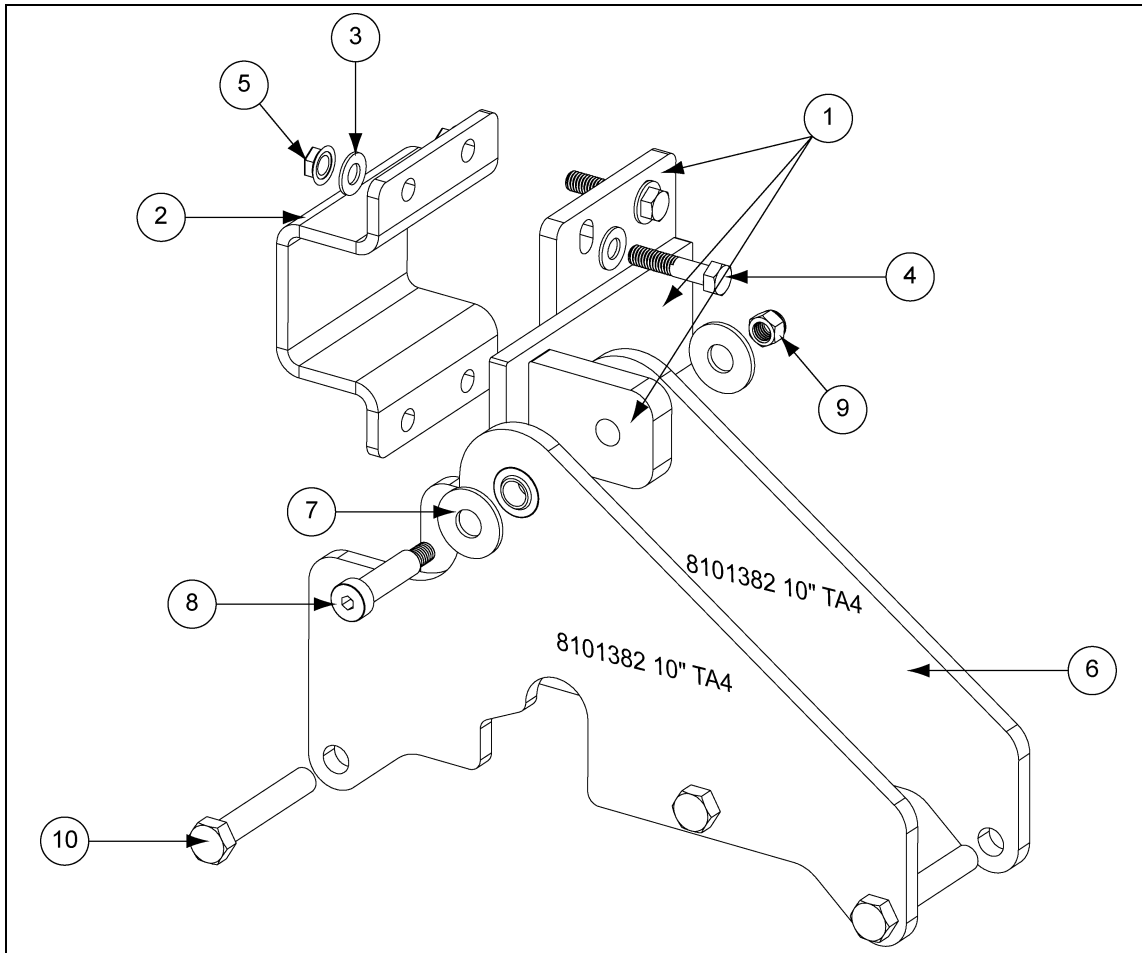

Chain Loop Torque Plate Assembly Parts List

Ref #	Part #	Description	Qty
1	8101380	Torque Plate Anchor Bracket	1
2	8101346	8" and 10" C-Clamp Bracket	1
2		12" C-Clamp Bracket	1
3	S-7409	Flat Washer 3/8" SAE ZN Grade 2	8
4	S-8322	Bolt, HHCS 3/8"-16 x 1-3/4" ZN Grade 5	4
5	S-968	Flange Nut 3/8"-16 ZN Grade 5	4
6	8101385	TA3 - 8" and 10" Torque Plate with Bearing	2
6	8101383	TA4 - 8" and 10" Torque Plate with Bearing	2
6	8101381	TA5 - 10" Torque Plate with Bearing	2
6		TA5 - 12" Torque Plate with Bearing	2
6		TA6 - 12" Torque Plate with Bearing	2
7	S-2121	Flat Washer 1/2" x 1-3/8" x 0.109" Type A ZN	2
8	S-9466	Shoulder Bolt 3/18"-16 x 1/2" x 1-3/4" SKT HD	1
9	S-7383	Nylock Nut 3/8"-16 ZN Grade 5	1
10	S-7687	TA3 - Bolt, HHCS 3/8"-16 x 2" ZN	3
10	S-8252	TA4 and TA5 - Bolt, HHCS 1/2"-13 x 3" ZN	3

GSI Group, LLC Limited Warranty

The GSI Group, LLC ("GSI") warrants products which it manufactures to be free of defects in materials and workmanship under normal usage and conditions for a period of 12 months after sale to the original end-user or if a foreign sale, 14 months from arrival at port of discharge, whichever is earlier. The end-user's sole remedy (and GSI's only obligation) is to repair or replace, at GSI's option and expense, products that in GSI's judgment, contain a material defect in materials or workmanship. Expenses incurred by or on behalf of the end-user without prior written authorization from the GSI Warranty Group shall be the sole responsibility of the end-user.

Warranty Extensions:

The Limited Warranty period is extended for the following products:

	Product	Warranty Period	
AP Fans and Flooring	Performer Series Direct Drive Fan Motor	3 Years	* Warranty prorated from list price: 0 to 3 years - no cost to end-user 3 to 5 years - end-user pays 25% 5 to 7 years - end-user pays 50% 7 to 10 years - end-user pays 75%
	All Fiberglass Housings	Lifetime	
	All Fiberglass Propellers	Lifetime	
Cumberland Feeding/Watering Systems	Feeder System Pan Assemblies	5 Years **	** Warranty prorated from list price: 0 to 3 years - no cost to end-user 3 to 5 years - end-user pays 50%
	Feed Tubes (1-3/4" and 2.00")	10 Years *	
	Centerless Augers	10 Years *	
	Watering Nipples	10 Years *	
Grain Systems	Grain Bin Structural Design	5 Years	† Motors, burner components and moving parts not included. Portable dryer screens included. Tower dryer screens not included.
Grain Systems Farm Fans Zimmerman	Portable and Tower Dryers	2 Years	
	Portable and Tower Dryer Frames and Internal Infrastructure †	5 Years	

GSI further warrants that the portable and tower dryer frame and basket, excluding all auger and auger drive components, shall be free from defects in materials for a period of time beginning on the twelfth (12th) month from the date of purchase and continuing until the sixtieth (60th) month from the date of purchase (extended warranty period). During the extended warranty period, GSI will replace the frame or basket components that prove to be defective under normal conditions of use without charge, excluding the labor, transportation, and/or shipping costs incurred in the performance of this extended warranty.

Conditions and Limitations:

THERE ARE NO WARRANTIES THAT EXTEND BEYOND THE LIMITED WARRANTY DESCRIPTION SET FORTH ABOVE. SPECIFICALLY, GSI MAKES NO FURTHER WARRANTY OF ANY KIND, EXPRESS OR IMPLIED, INCLUDING, WITHOUT LIMITATION, WARRANTIES OF MERCHANTABILITY OR FITNESS FOR A PARTICULAR PURPOSE OR USE IN CONNECTION WITH: (I) PRODUCT MANUFACTURED OR SOLD BY GSI OR (II) ANY ADVICE, INSTRUCTION, RECOMMENDATION OR SUGGESTION PROVIDED BY AN AGENT, REPRESENTATIVE OR EMPLOYEE OF GSI REGARDING OR RELATED TO THE CONFIGURATION, INSTALLATION, LAYOUT, SUITABILITY FOR A PARTICULAR PURPOSE, OR DESIGN OF SUCH PRODUCTS.

GSI shall not be liable for any direct, indirect, incidental or consequential damages, including, without limitation, loss of anticipated profits or benefits. The sole and exclusive remedy is set forth in the Limited Warranty, which shall not exceed the amount paid for the product purchased. This warranty is not transferable and applies only to the original end-user. GSI shall have no obligation or responsibility for any representations or warranties made by or on behalf of any dealer, agent or distributor.

GSI assumes no responsibility for claims resulting from construction defects or unauthorized modifications to products which it manufactured. Modifications to products not specifically delineated in the manual accompanying the equipment at initial sale will void the Limited Warranty.

This Limited Warranty shall not extend to products or parts which have been damaged by negligent use, misuse, alteration, accident or which have been improperly/inadequately maintained. This Limited Warranty extends solely to products manufactured by GSI.

Prior to installation, the end-user has the responsibility to comply with federal, state and local codes which apply to the location and installation of products manufactured or sold by GSI.

This equipment shall be installed in accordance with the current installation codes and applicable regulations, which should be carefully followed in all cases. Authorities having jurisdiction should be consulted before installations are made.

G S I G R O U P



GSI Group
1004 E. Illinois St.
Assumption, IL 62510-0020
Phone: 1-217-226-4421
Fax: 1-217-226-4420
www.gsiag.com



GSI is a worldwide brand of AGCO Corporation.