

Pneumatic Grain Conveying

4" - 700 Bu/Hr

5" - 1200 Bu/Hr

5" - 1700 Bu/Hr

Owner's Manual

PNEG-1355

Date: 03-29-07

GSI GROUP



PNEG-1355

Contents

Chapter 1 Safety 5
 Safety Guidelines 5

Chapter 2 Decals 9

Chapter 3 Maintenance 11
 Maintenance Schedule 11

Chapter 4 Air System 12
 Air System Capacities (Dry Shelled Corn) 12
 Capacity Chart (4" & 5" Systems) 12

Chapter 5 Installation 13
 Air System Installation Instructions 13
 Air System Capacities (Dry Shelled Corn) 14
 Air System Tubing Dimensions 16

Chapter 6 Dimensions 18
 Elbow Angle Measurements 18

Chapter 7 Assembly 19
 Air System Set-Up Procedures 19
 Air System Control Box Definitions 25

Chapter 8 O/L Thermals 27

Chapter 9 Wiring 28
 Standard Schematic With Digital Amp Meter 28
 Standard Schematic With Analog Amp Meter Using 2EL0273 Control Relay 29
 Schematic With Analog Amp Meter Using HF-7203 Control Relay 30
 Twin Schematic With Digital Amp Meter 31
 Twin Schematic With Analog Amp Meter Using 2EL0273 Control Relay 32
 Twin Schematic With Analog Amp Meter Using HF-7203 Control Relay 33

Chapter 10 Operation and Management 34
 Control Box Operational Procedures 34
 Air System Operation Guidelines 35

Chapter 11 Hook-Up Diagrams 38

Table of Contents

Chapter 12 Parts List	39
4" (700) & 5" (1200) Standard Blower Parts	40
4" & 5" Twin Blower Parts	42
5" (1700) Hi-Capacity Blower Parts	44
5" (1700) Twin Hi-Capacity Blower Parts	46
4" & 5" Blower Filters	48
4" & 5" Airlock Parts	50
Airlock Inlet Transition Assembly	52
Panel Module Assembly - Digital	54
Panel Module Assembly - Analog	55
Switch Panel Assembly - Standard	56
Switch Panel Assembly - Twin	57
Standard Control Panel Assembly - 230 V 10-30 HP	58
Standard Control Panel Assembly - 230 V 10-30 HP Used In 8015071 Control Box (CSA Listed)	60
Standard Control Panel Assembly - 230 V 40 HP	62
Twin Control Panel Assembly - 230 V 7-15 HP	64
Twin Control Panel Assembly - 230 V 7-15 HP Used in 8015114 Control Box (CSA Listed)	66
Standard Control Panel Assembly - 460 V 10 - 40 HP	68
Control Panel Assembly - 460 V 10-40 HP Used In 8015072 Control Box (CSA Listed)	70
Chapter 13 Troubleshooting	72
Chapter 14 Couplings	74
How to Handle Handling Couplings	74
Chapter 15 Warranty	75

Safety Guidelines

This manual contains information that is important for you, the owner/operator, to know and understand. This information relates to protecting **personal safety** and **preventing equipment problems**. It is the responsibility of the owner/operator to inform anyone operating or working in the area of this equipment of these safety guidelines. To help you recognize this information, we use the symbols that are defined below. Please read the manual and pay attention to these sections. Failure to read this manual and it's safety instructions is a misuse of the equipment and may lead to serious injury or death.



This is the safety alert symbol. It is used to alert you to potential personal injury hazards. Obey all safety messages that follow this symbol to avoid possible injury or death.



DANGER indicates an imminently hazardous situation which, if not avoided, will result in death or serious injury.



WARNING indicates a potentially hazardous situation which, if not avoided, could result in death or serious injury.



CAUTION indicates a potentially hazardous situation which, if not avoided, may result in minor or moderate injury.



CAUTION used without the safety alert symbol indicates a potentially hazardous situation which, if not avoided, may result in property damage.



NOTE indicates information about the equipment that you should pay special attention to.

1. SAFETY

Follow Safety Instructions

Carefully read all safety messages in this manual and on your machine safety signs. Keep signs in good condition. Replace missing or damaged safety signs. Be sure new equipment components and repair parts include the current safety signs. Replacement safety signs are available from the manufacturer.

Learn how to operate the machine and how to use controls properly. Do not let anyone operate without instruction.

Keep your machinery in proper working condition. Unauthorized modifications to the machine may impair the function and/or safety and affect machine life.

If you do not understand any part of this manual and need assistance, contact your dealer.

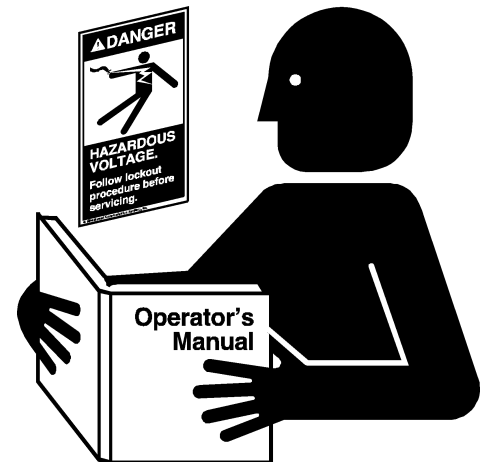

Stay Clear of Moving Parts and Air valves

Keep hands and feet away from moving parts. Be sure all people are clear of the equipment before start-up. Wear close fitting clothing.

Keep all shields and covers in place at all times.

Stay clear of air blast for valve. Always wear safety glasses to protect your eyes.

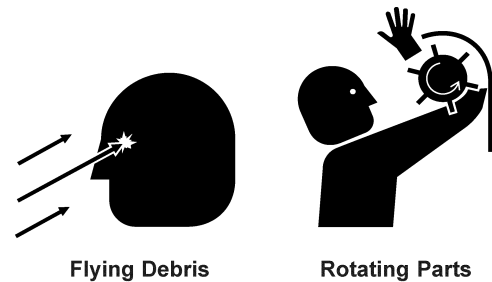

Install and Use equipment Properly

Ground all electrical equipment as well as the bin itself.

Disconnect all power before servicing or opening control box, adjusting, lubricating the equipment, or opening the control box inner panel.

All electrical hook-ups should be in accordance with local and National Electrical Code.

If three phase power is used, identify wild leg and wire according to electrical diagram.

Never use plastic tubing for any lines carrying grain.

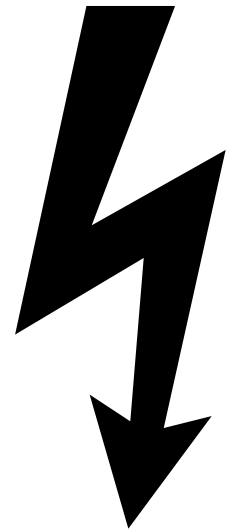

Practice Safe Maintenance

Understand service procedures before doing work. Keep area clean and dry.

Never lubricate, service, or adjust machine while it is in operation. Stop and lock out power source before making adjustments, cleaning, or maintaining equipment.

Keep all parts in good condition and properly installed. Fix damage immediately. Replace worn or broken parts. Remove any build up of grease, oil, or debris.



Prepare for Emergencies

Be prepared if fire starts.

Keep a first aid kit and fire extinguisher handy.

Keep emergency numbers for doctors, ambulance service, hospital, and fire department near your telephone.

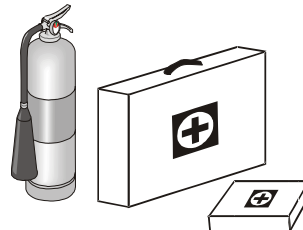

Keep Emergency Equipment Quickly Accessible.

1. SAFETY

Wear Protective Clothing

Wear close fitting clothing and safety equipment appropriate to the job.

Safety glasses should be worn at all times to protect eyes from debris.

Eye Protection

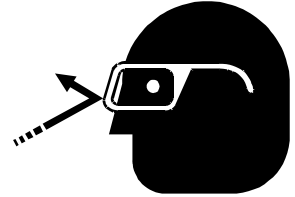

Wear gloves to protect your hands from sharp edges on plastic or steel parts.

Gloves



Wear steel toe boots to help protect your toes from falling debris.

Steel Toe Boots



A respirator may be needed if a hog house has poor ventilation. Waste fumes can be toxic.

Respirator

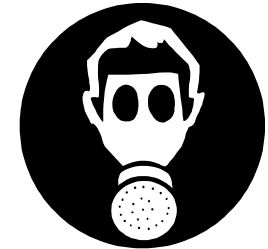

Remove all jewelry.

Tuck in any loose or dangling shoe strings.

Long hair should be tied up and back.

Wear hard hat to help protect your head.

Hard Hat



2. DECALS

Install safety decals on components as shown in the decal section. Always insure that safety decals are in a place, easily readable, and in good condition. If a decal cannot be easily read for any reason or has been painted over, replace it immediately. Contact your dealer or the manufacturer to order a replacement decal free of charge.

For decal replacements contact GSI at:

1004 E. Illinois Street
 Assumption, IL 62510
 Ph: 217-226-442

DC-1749

DC-994

N10080

DC-1382

N10090

2. DECALS



DC-1386



DC-995

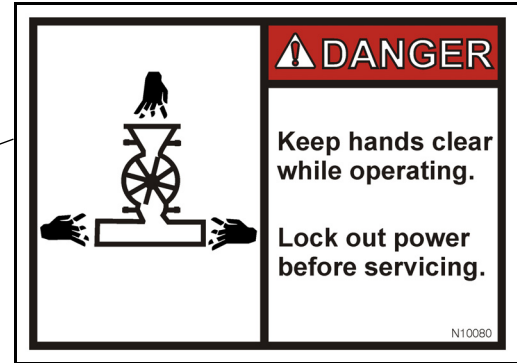
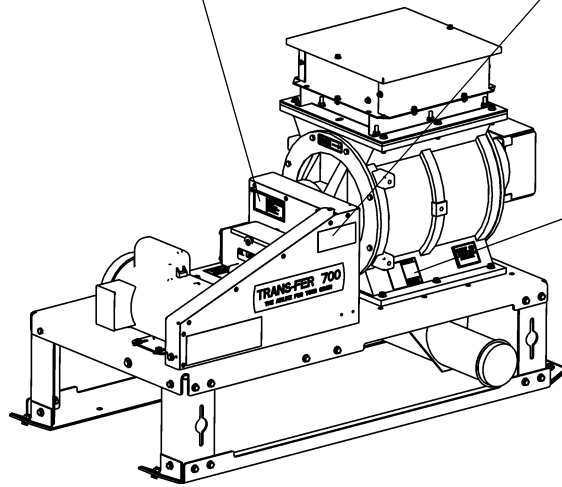

N10080

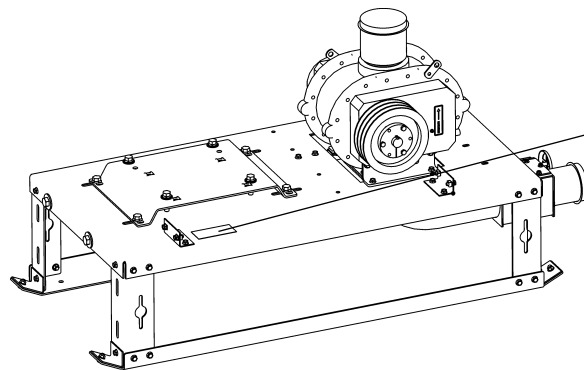

DC-994

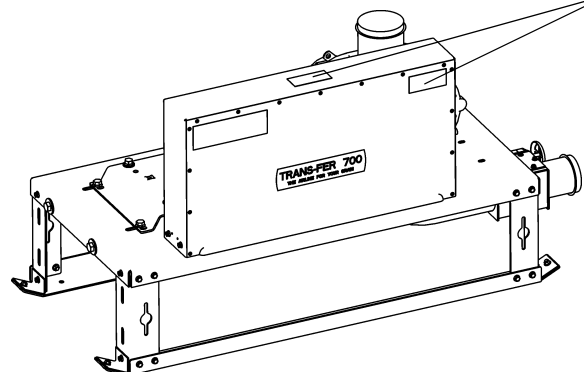

DC-995

Maintenance Schedule

Initial Start-Up	
<ol style="list-style-type: none"> 1. Roots - Flo Blower 2. Roots Blower 3. Air Lock Gearbox 4. Air Filter 5. V-belts 6. Chain 7. Tubing System 	<p>*2004 & Later Production - Use MS5389. Older units use non-detergent 50W.</p> <ol style="list-style-type: none"> 1. Oil level with middle of sight glass (DMC #MS5389 synth. oil.) 2. Oil level to check plug.* 3. Oil level to check plug (SAE90) 4. Installed properly 5. Tensioned and aligned 6. Tensioned and aligned 7. All couplers tight. All tubing connections have good fit. Tubing laid out straight. Elbows fitting properly.
After First 10 Hours and Daily	
<ol style="list-style-type: none"> 1. Air Filter 2. V-belts 3. Tubing 	<ol style="list-style-type: none"> 1. Check for excessive dust build-up 2. Check tension alignment 3. Check all connections for leaks and signs of separating
Weekly	
<ol style="list-style-type: none"> 1. Roots Blower (Prior to 2004) 2. Chain 3. Blowers & Gearbox 	<ol style="list-style-type: none"> 1. Grease bearings until grease comes out of relief fitting (Shell Darina NLGI Grade #2) 2. Oil 3. Check oil levels.
1500 Hours (Synthetic Oil) - 500 Hours (Standard Oil)	
<ol style="list-style-type: none"> 1. Roots-Flo and Duraflow 2. Roots Blower (Prior to 2004) 3. Roots Blower-2004 & Later 	<ol style="list-style-type: none"> 1. Drain oil and replace with 1.5 Qts. of DMC #MS5389 synthetic oil. (Fill to middle of sight glass) 2. Drain oil and replace with 1 Qt. of Part No. MS-5389 or STD50W Non-Detergent Oil. (Fill to oil level plug) 3. Replace with 1.5 Qts. of Part No. MS5389. Add oil to both ends of blower. (Fill to middle of both sight glasses)
Extended Shut Down	
<p>Disconnect Main Power Unit</p> <ol style="list-style-type: none"> 1. Blower 2. Airlock 3. Chain 	<ol style="list-style-type: none"> 1. Remove inlet assembly and spray oil on lobes while rotating by hand, to prevent rust. Keep hands and objects out of blower. Re-install inlet assembly 2. Coat interior with oil, while rotating by hand, to prevent rust. Re-install weather cover. 3. Oil chain to prevent rust

4. AIR SYSTEM

Air System Capacities (Dry Shelled Corn)

Effective Length (Feet)	700 Bu/Hr 4" System (Roots)			1200 Bu/Hr 5" System (Roots)		1700 Bu/Hr 5" System (Roots-Flo)		
	10 HP Motor	15 HP Motor	20 HP Motor	20 HP Motor	30 HP Motor	20 HP Motor	30 HP Motor	40 HP Motor
50	525	800	850	1100	1300	1200	1600	1800
100	500	775	825	1075	1275	1175	1575	1775
150	475	750	800	1050	1250	1150	1550	1750
200	450	700	750	1000	1200	1100	1500	1700
250	400	650	700	925	1125	1025	1400	1600
300	350	575	625	825	1025	925	1275	1450
350	275	475	525	700	900	800	1100	1275
400	200	350	400	550	750	650	900	1050
450	-	-	225	350	550	450	650	775
500	-	-	-	-	-	-	-	400

Effective tube length is determined by adding the horizontal length, twice the vertical height and 10 feet for every elbow of 45° or greater. Add five feet for each elbow less than 45°. Use the horizontal run and add the vertical rise of inclined systems to calculate the effective length.

Capacity Chart (4" & 5" Systems)

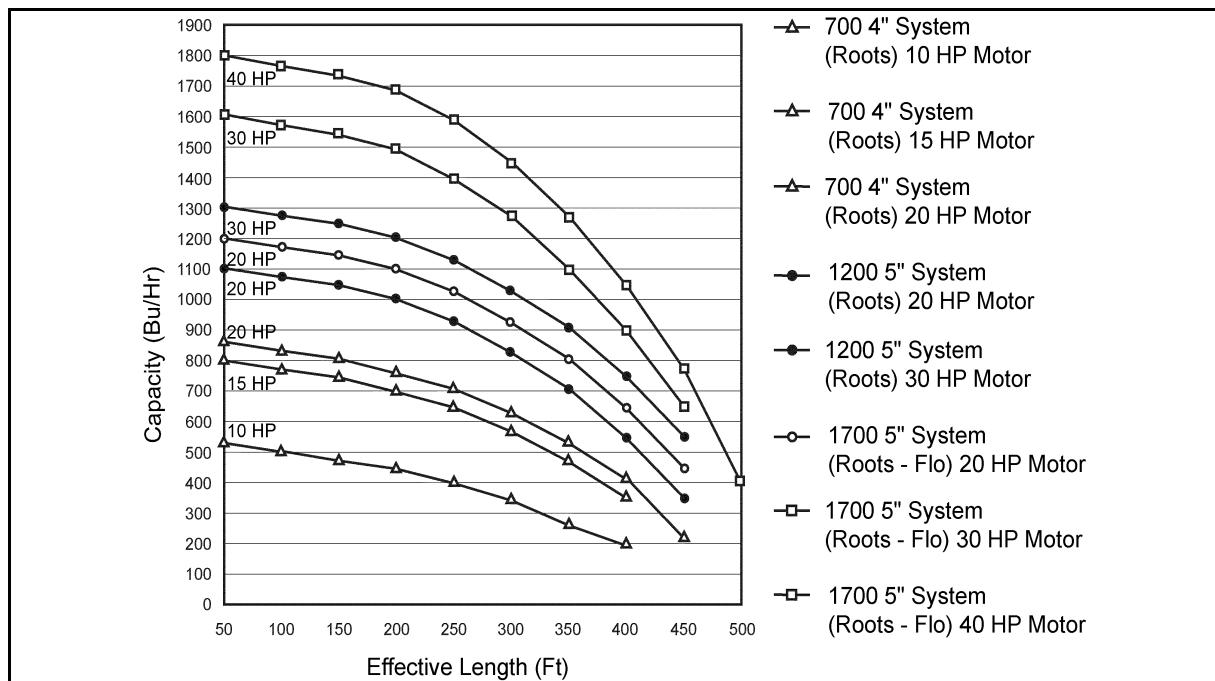

Air System Installation Instructions

1. Determine the most convenient location for the airlock and blower. Take into consideration the direction of the prevailing winds. It is important to locate the blower in as clean an environment as possible. This greatly reduces the maintenance requirements on the air filter system. When the distance between the airlock and blower is over 10 feet, it is best to use galvanized pipe with short flex hose on the ends to couple the units together to keep airflow restrictions to a minimum.
2. The noise level of the blower unit can be reduced by placing the unit behind a wall, barrier, or in a small building. If this is done, make sure that the building has adequate ventilation for both air intake and cooling of the blower and motor.
3. The grain discharge chute on the airlock is assembled at the factory so that grain movement is at 90° to the length of the skid. This orientation can be changed by removing the mounting hardware at the base of the airlock and rotating the discharge chute to the preferred direction. Be sure to keep the gasket in place between the skid and the discharge chute. Note that the airlock itself is sealed to the skid surface and does not need to be moved to redirect the discharge chute.

Note: A minimum of 10 feet is needed between the airlock discharge and the first elbow in the system.

4. Determine the best routing of the galvanized steel pipe from the airlock to the storage areas. Use galvanized elbows for changing the grain direction. This will give better performance and longer life than flexhose.
5. Bolt the tube mounting brackets to the desired location using at least two (2) mounting brackets on the vertical wall and two (2) on the roof of the grain bin. The mounting brackets can be formed to match existing hole patterns in the bin.
6. Determine the number and degree of arc required in the elbows. The 90° and 60° elbows are standard - different lengths of arc can be cut from these standard elbows.
(See Page 18).

Note: A minimum of eight (8) feet between elbows is required for proper operation.

7. Cut the steel tubing to the required length and fasten it together with compression couplings. The ends must be cut square to fit properly. Make sure that the stainless steel gasket protecting sleeve is placed over the joint before tightening the coupler. Tighten the three bolts on the coupler evenly or until the coupler flanges butt together (See Page 74).
8. The steel tubing can be laid underground, on top of the ground or placed on blocks. If placed on blocks, the tubing must be supported every 15 feet. If placed underground, the tube should enter and exit the ground at a 45° angle and be coated with a protective tar to prevent corrosion.

5. INSTALLATION

9. Measure the distance between the airlock and blower. Use flex hose or a combination of flex hose and galvanized tubing to connect the units together. Note that the grain discharge chute on the airlock is tapered and that grain can discharge in either direction.
10. Install all tubing required to transfer grain to your storage areas.
11. To attach the deadhead deflector to the tubing, simply slide the deadhead deflector onto the tubing and tighten the clamp provided. Flexible galvanized tubing can be attached to the deadhead down spout if needed. If a cyclone is used, an elbow and mounting brackets are needed.
12. Select a location to mount the electrical control box that is accessible and easily reached should shut down of unit be necessary. It should be close enough to the blower to run the 30 feet of rubber pressure hose between the blower and the control box. Otherwise, a longer length of hose must be ordered.
13. Before wiring or operating the Air System unit, read the control box description on pages 18 and 24 to understand the operation of the Air System control box. If the control box is to be wired to remote equipment, review the wiring diagrams for proper hook-up.

Air System Capacities (Dry Shelled Corn)

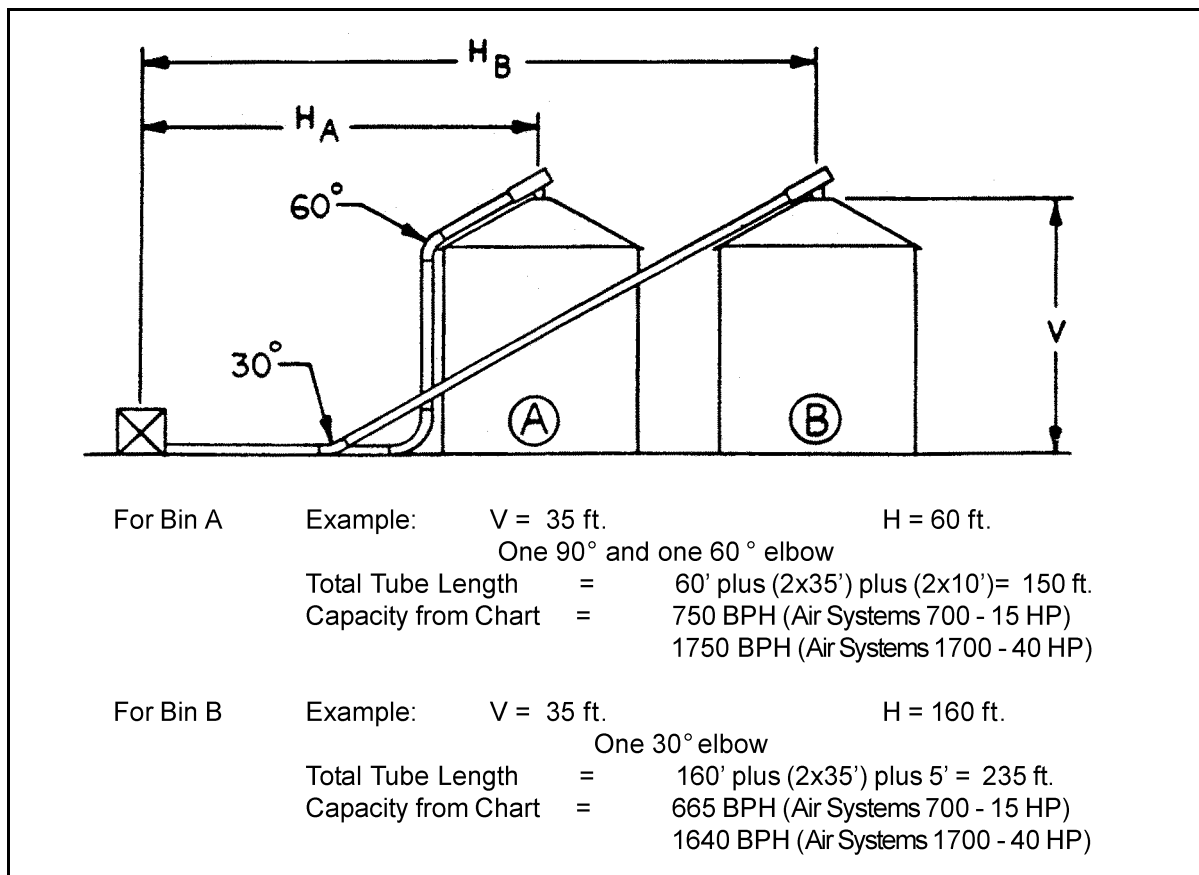

Figure 5A

NOTES

5. INSTALLATION

Air System Tubing Dimensions

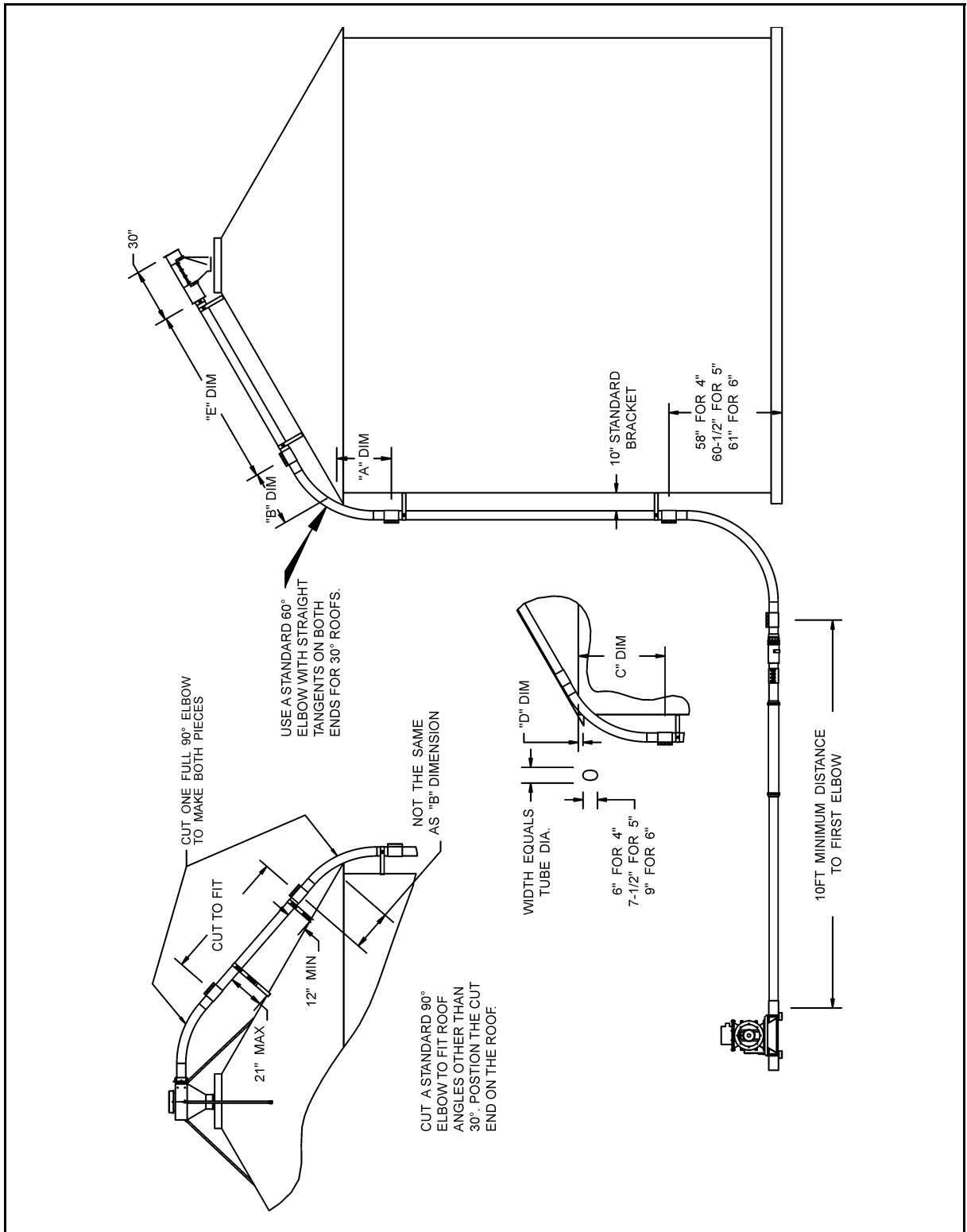

Figure 5B

System Size	Roof Angle	Reference Dimension											
		A	B	C	D	E							
		18' Dia.	21' Dia.	24' Dia.	27' Dia.	30' Dia.	33' Dia.	36' Dia.	42' Dia.				
4"	25	31"	23"	47-1/2"	5-3/4"	7' 1"	8' 9"	10' 5"	12' 1"	13' 9"	15' 5"	17' 1"	20' 5"
	30	29"	29"	46"	3-1/2"	7' 1"	8' 9"	10' 5"	12' 1"	13' 9"	15' 5"	17' 1"	20' 5"
	35	27"	19"	45"	2-1/2"	8' 6"	10' 2"	11' 10"	13' 6"	15' 2"	16' 10"	18' 6"	21' 10"
5"	25	32-1/2"	22-1/2"	50"	4-1/2"	7'	8' 9"	10' 6"	12' 3"	14'	15' 9"	17' 6"	21'
	30	30-1/2"	30-1/2"	49"	3-1/4"	6' 10"	8' 7"	10' 4"	12' 1"	13' 10"	15' 7"	17' 4"	20' 10"
	35	28-1/2"	18-1/2"	48"	2-1/4"	8' 6"	10' 3"	12'	13' 9"	15' 6"	17' 3"	19'	22' 6"
6"	25	32-1/4"	22-1/4"	51"	4-1/2"	7' 3"	9' 1"	10' 11"	12' 9"	14' 7"	16' 5"	18' 3"	21' 11"
	30	30-1/4"	30"	50"	3"	7' 1"	8' 11"	10' 9"	12' 7"	14' 5"	16' 3"	18' 1"	21' 9"
	35	28-1/4"	18"	49"	2"	8' 8"	10' 6"	12' 4"	14' 2"	16'	17' 10"	19' 9"	22' 4"

Add 10" to E dimension if roof elbow has been cut from a 90° Elbow.

6. DIMENSIONS

Elbow Angle Measurements

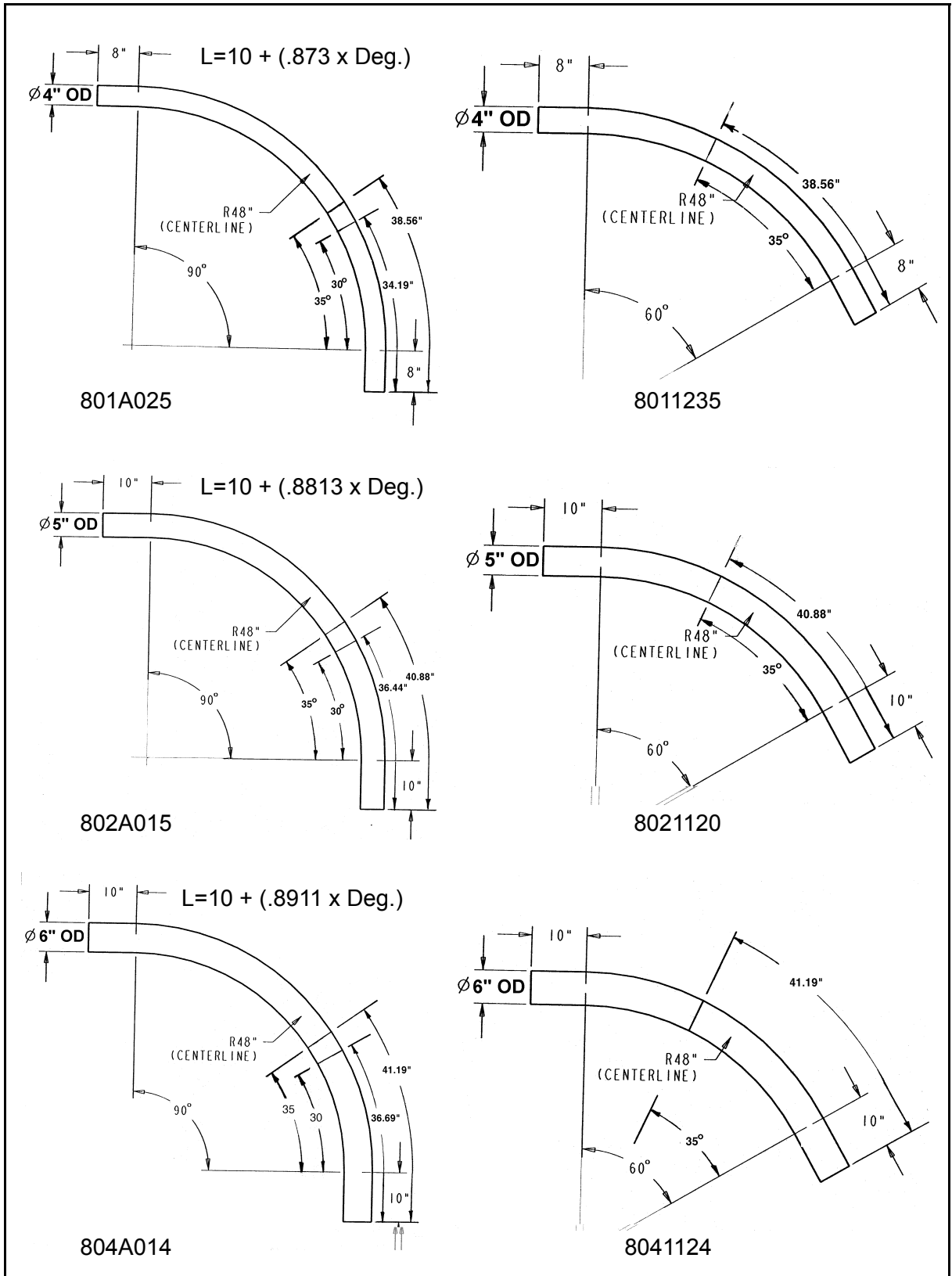

Air System Set-Up Procedures

1. The air filter extension tube and housing are connected to the blower inlet by a compression coupler. For extended filter life, if the pneumatic system is being operated in extremely dirty conditions, a longer extension tube can be used between the blower inlet and the air filter. **BE SURE** the air filter is positioned so that routine inspection and service can be performed.
2. Place the air filter element with pre-filter on the base and cover with the filter canister using the 3/8" wing nut and washer. The wing nut does not need to be more than finger tight. *(See Figure 7A).*

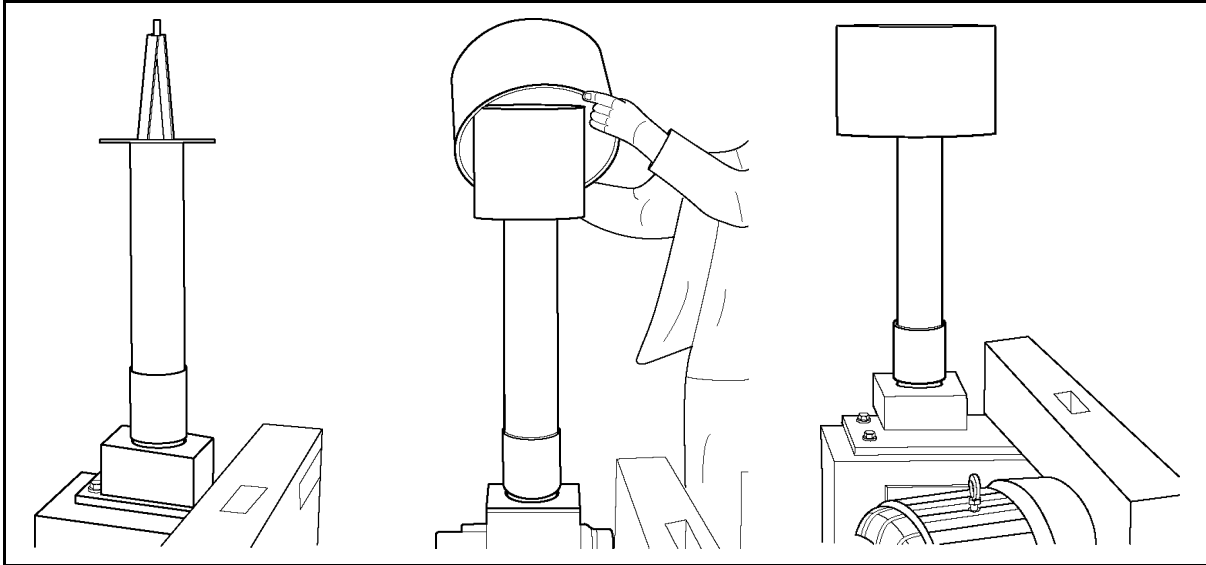

Figure 7A

3. Check the motor name plate for the correct motor frame size. Remove the hardware shipped in the Motor Mounting Plate. Locate the motor on the mounting plate using the hole pattern, which aligns with the motor base. Bolt the motor securely to the mounting plate with the supplied hardware that was previously removed. Loosen the (4) 1/2" flange head bolts, which secure the motor Mounting Plate to the blower base. *(See Figure 7B).*

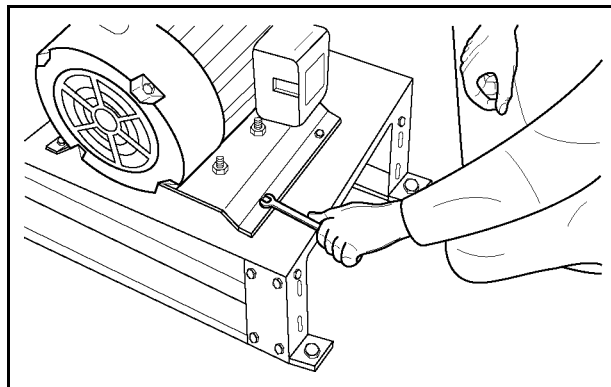

Figure 7B

7. ASSEMBLY

4. Place the specified pulley onto the motor and align it with the blower pulley.
(See [Figure 7C](#)).

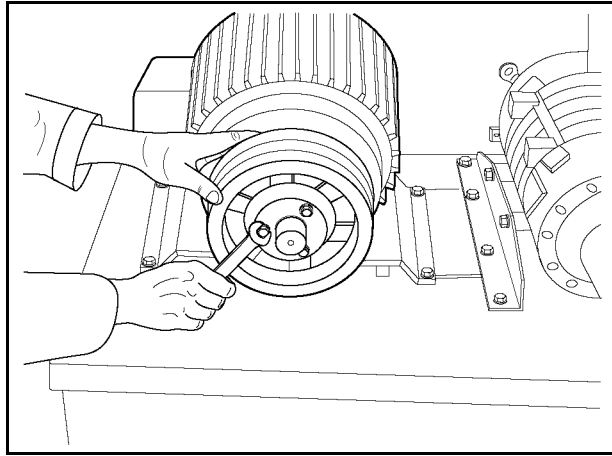

Figure 7C

5. [See Figure 7D](#) Place the matching set of V-belts on the pulleys. Tighten the belts by evenly turning the cap screws clockwise. Belts should have 3/8" deflection at ten pounds pressure per belt. ([See Figure 7E](#)).

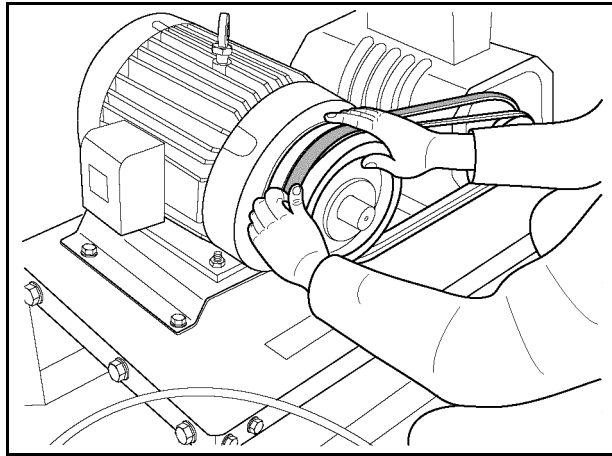

Figure 7D

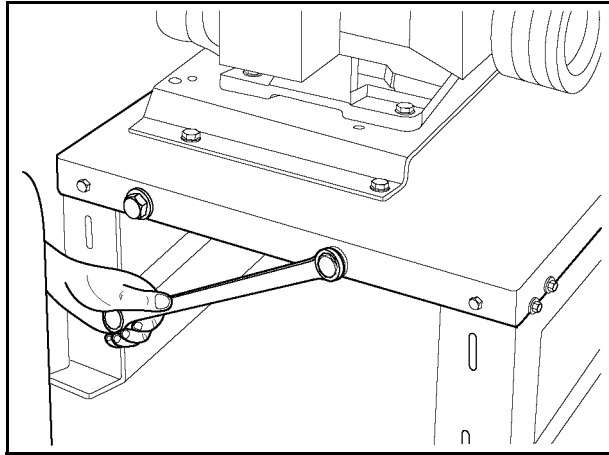

Figure 7E

⚠ CAUTION ⚠

Too much tension on belts will cause blower damage.

6. Keeping the motor in proper alignment is necessary and can be accomplished by using an open-end wrench to turn the nut on the take-up bolt closest to the rear of the motor. This nut is located behind the flange of the blower base. Adjust if necessary. Tighten the (4) flange head bolts that secure the motor mounting plate to the blower base. Re-Install Drive Shield. (See [Figure 7F](#))

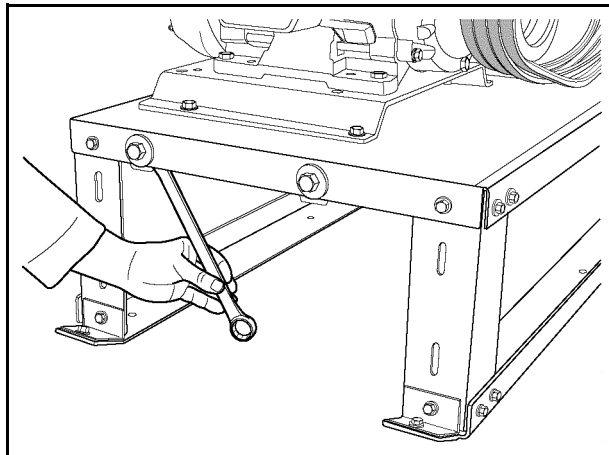

Figure 7F

⚠ CAUTION ⚠

Rotate the motor by hand and listen for any rubbing or knocking by either the motor or the blower. When the motor is wired, it must be checked for CCW rotation.

7. ASSEMBLY

7. The oil level should be at the center of the sight glass on the blower. Add part number MS5389 if required. **DO NOT OPERATE BLOWER UNTIL CORRECT OIL LEVEL IS INDICATED!** The 4" roots blower has sight glasses on both ends. Be sure oil levels are indicated on both sight glasses. (See [Figure 7G](#)).

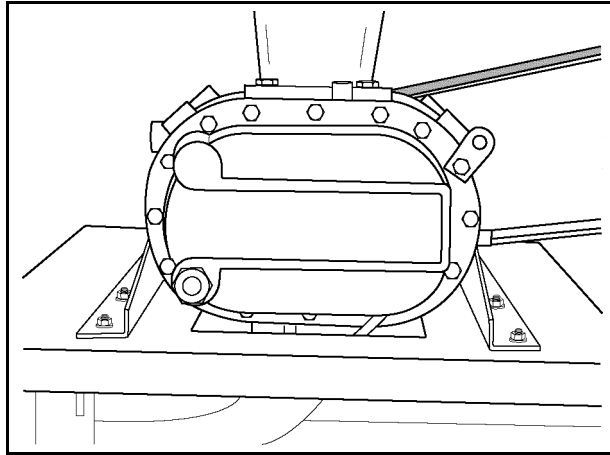

Figure 7G

8. Using four (4) 5/16" x 3/4" flange head bolts, mount the motor to the airlock deck. Place the specified pulley on to the motor shaft and align to pulley on gearbox. (See [Figure 7H](#)).

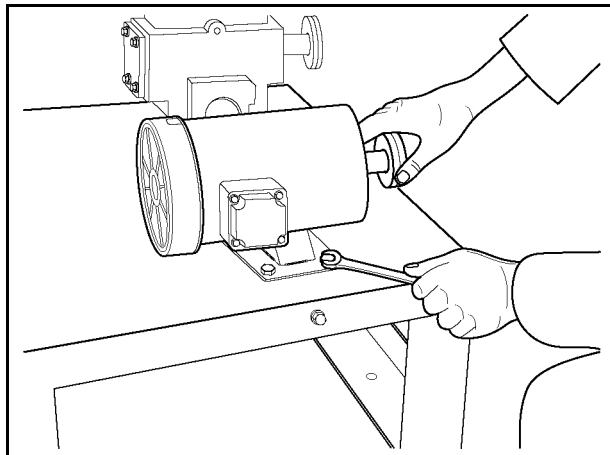

Figure 7H

7. ASSEMBLY

- Next, place the A-24 belt onto the pulleys. [See Figure 7I](#) Tighten the belt to its proper tension of 3/8" deflection at ten pounds of pressure by pulling motor away from gearbox. Tighten the four 5/16" flange bolts on the motor base. Replace the belt shield.

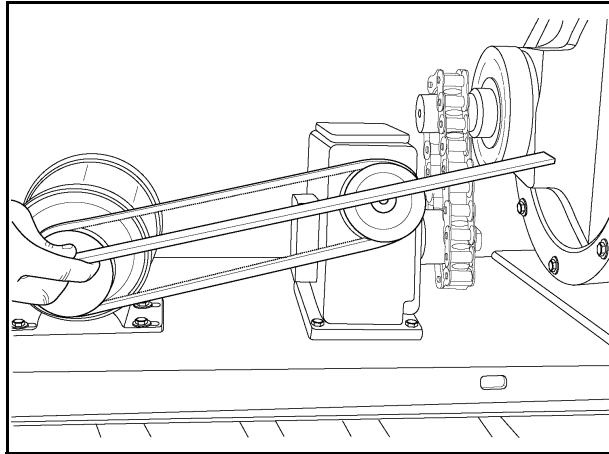

Figure 7I

- Check the oil level in the gearbox by removing the plug and noting if the oil is at this level. Add SAE 80-90 gear lubricant if required. [\(See Figure 7J\)](#)

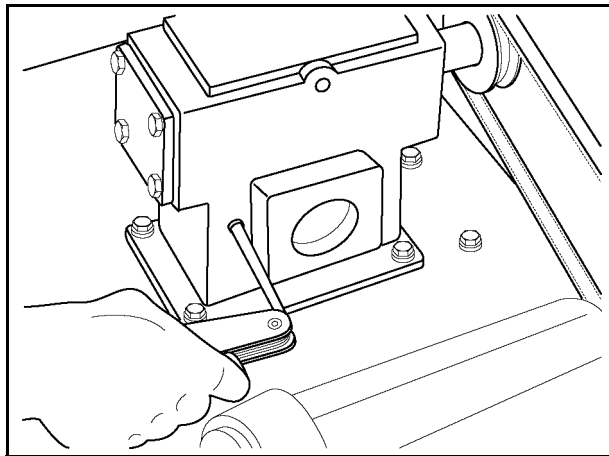

Figure 7J

7. ASSEMBLY

11. Remove 1/4" pipe plug in gate valve pipe. Install gauge assembly and attach air hose.
(See Figure 7K)

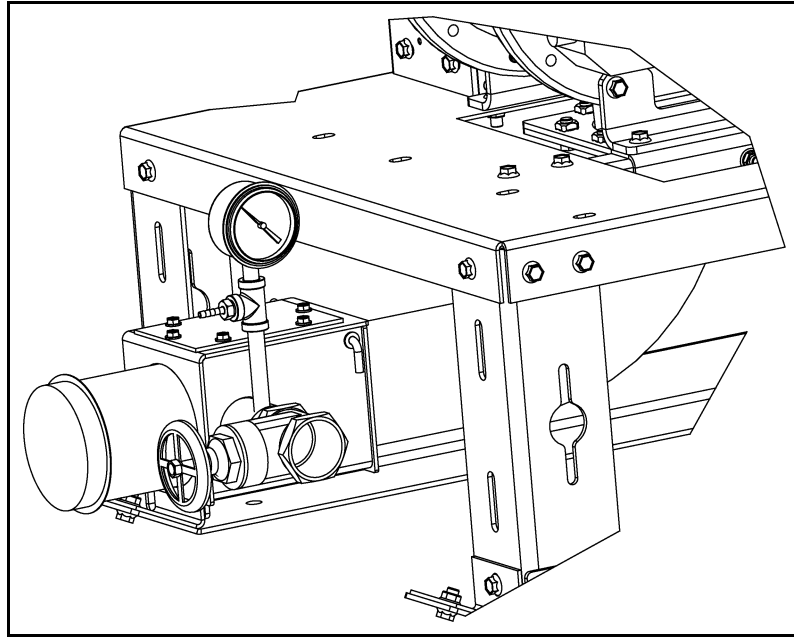

Figure 7K

THE SET-UP OF THE PNEUMATIC AIR SYSTEM IS NOW COMPLETE.

Air System Control Box Definitions

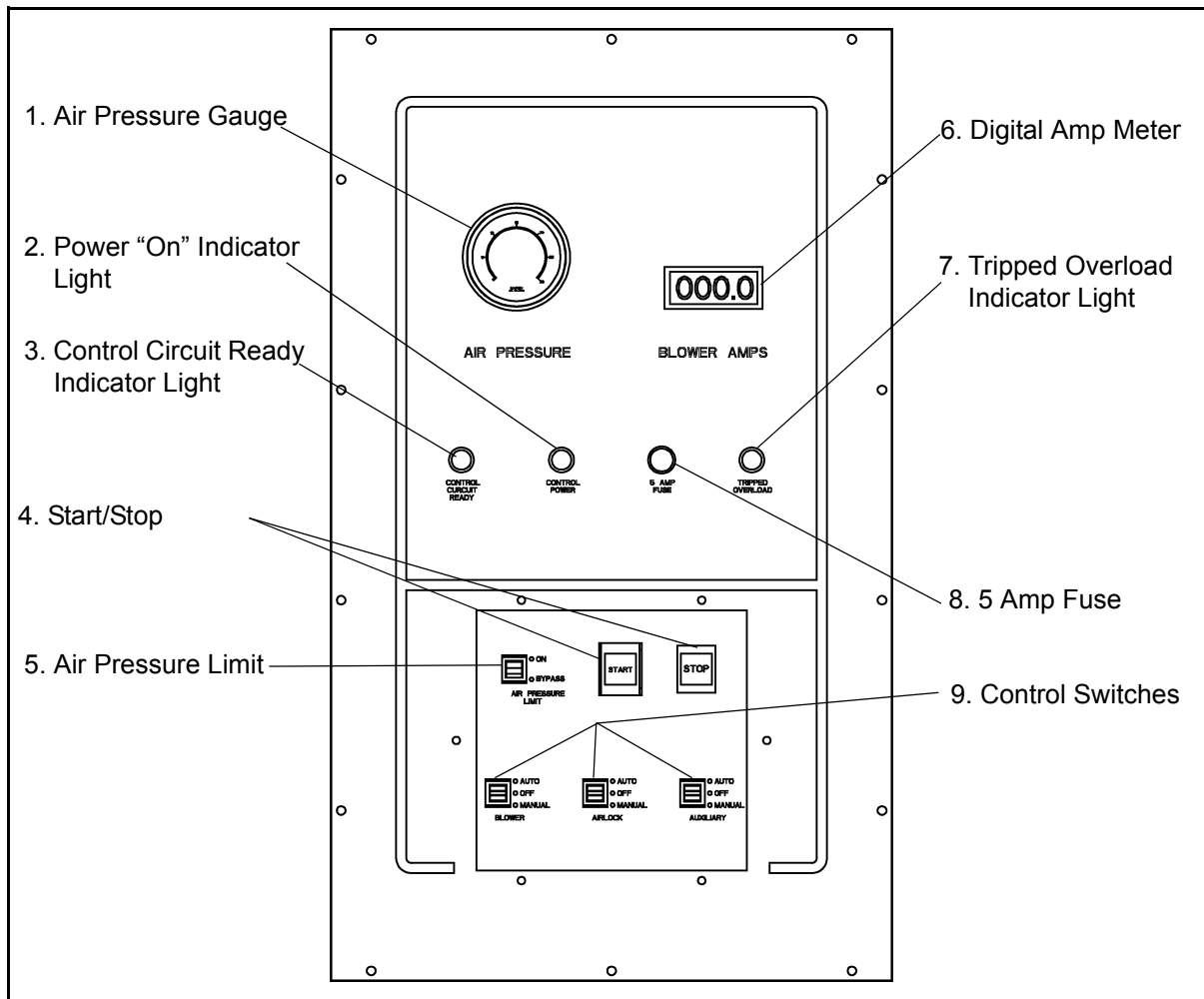

Figure 7L

1. Air Pressure Gauge: This gauge indicates the system air pressure.
2. Power-On Indicator Light: This lamp will light up when power is supplied to the control box.
3. Control Circuit Ready Indicator Light: This lamp will light up when the start button has been pushed and all control circuits are completed. When lit and in the automatic mode, the air system will run whenever it receives a signal to start.
4. Start-Stop Switch: The start button must be pushed before any part of the Air System can be run. Pushing the stop button will immediately stop all functions.
5. Air Pressure Limit Control Switch: When in the "On" position, this switch will allow the air pressure switch to immediately shut down the air system whenever the air pressure exceeds preset conditions.
6. Amp Meter: The Amp meter measures the current flow to the blower motor.

7. ASSEMBLY

7. Tripped Overload Indicator Light: This lamp will light up when any of the motor thermal overloads in the control box has tripped. The overloads for all three circuits (Aux, Airlock, and Blower) must have thermal overloads installed to operate the system. See Thermal Unit chart Drawing on [page 27](#).
8. 5 Amp Fuse: A five (5) Amp fuse protects the electrical components in the control box.
9. Control Switches: The operation of the blower, airlock and auxiliary equipment of the air system is controlled by placing these switches in the "Auto", "Manual" or "Off" position.
10. Automatic Control Terminals: When the air system is ready to run (i.e., the control ready light is on), the system can then be started and run by completing the circuit between terminals one (1) and two (2). The blower, airlock or auxiliary equipment will not run in the automatic mode unless terminals one (1) and two (2) are connected. For example, a closing set of contacts in a dryer control box would complete the circuit between terminals one (1) and two (2) and automatically start the air system. (See [Figure 7M](#)).

⚠ WARNING ⚠

No voltage should be supplied to terminals one (1) and two (2). See the diagram on [Page 28-33](#) and drawing below.

11. Remote Shut-Down Control: A remote piece of equipment can be caused to shutdown with the air system by putting terminals three (3) and four (4) in series with the control circuit of the remote equipment. This circuit has a maximum current rating of 10 Amps. The circuit between terminals three (3) and four (4) is closed whenever the control circuit ready light is on, regardless of the position of the control switches. ("AUTO", "OFF" or "ON") See the Diagram on [Page 28-33](#) and [page 38](#)

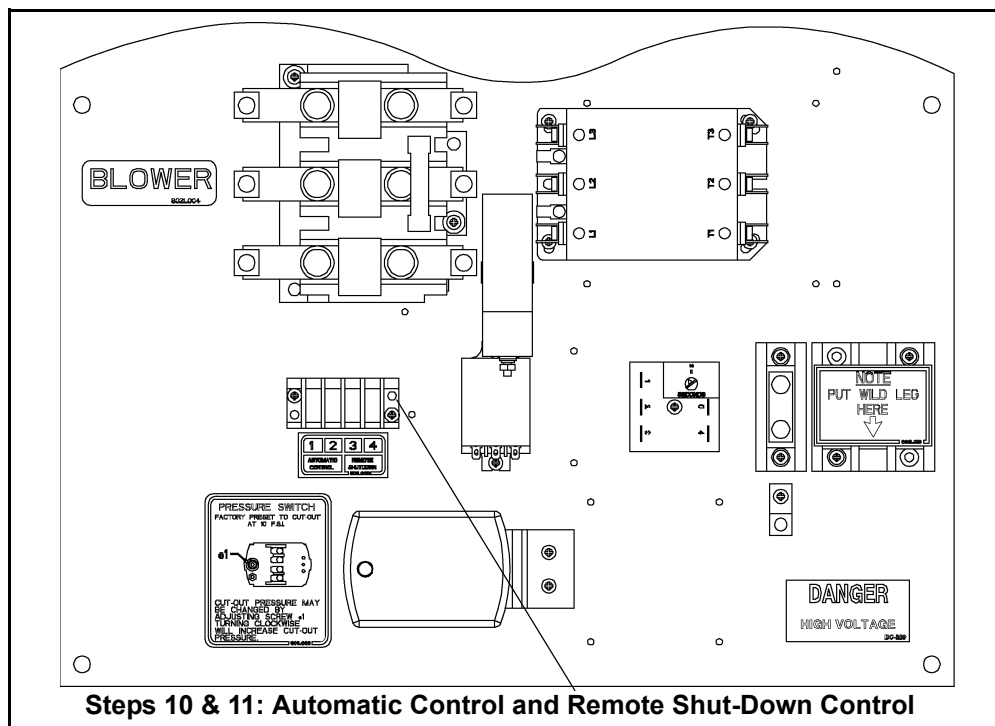

Figure 7M

Air System Control Box - Thermal Unit Chart

SINGLE MOTOR	1EL0861 #B 3.00 THERMAL UNIT	1EL0859 #B 4.15 THERMAL UNIT	1EL0769 #B 6.90 THERMAL UNIT	1EL0767 #B 9.10 THERMAL UNIT	1EL0763 #B 11.5 THERMAL UNIT	1EL0761 #B 14 THERMAL UNIT	1EL0795 #CC 20.9 THERMAL UNIT	1EL0796 #CC 26.3 THERMAL UNIT	1EL0797 #CC 33.3 THERMAL UNIT	1EL0788 #CC 39.6 THERMAL UNIT	1EL0793 #CC 54.5 THERMAL UNIT	1EL0790 #CC 64.3 THERMAL UNIT	1EL0794 #CC 68.5 THERMAL UNIT	1EL0804 #CC 74.6 THERMAL UNIT	1EL0791 #CC 112 THERMAL UNIT	1EL0812 #CC 156 THERMAL UNIT
4" 700 10HP, 230V, 1PH					3	3						3				
4" 700 10HP, 230V, 3PH			3	3						3						
4" 700 10HP, 440V, 3PH	3	3					3									
4" 700 15HP, 230V, 1PH					3	3								3		
4" 700 15HP, 230V, 3PH			3	3							3					
4" 700 15HP, 440V, 3PH	3	3						3								
4" 700 20HP, 230V, 3PH			3	3									3			
4" 700 20HP, 440V, 3PH	3	3							3							
5" 1200 20HP, 230V, 3PH			3	3									3			
5" 1200 20HP, 440V, 3 PH	3	3							3							
5" 1200 30HP, 230V, 3PH			3	3											3	
5" 1200 30HP, 440V, 3PH	3	3									3					
5" 1700 20HP, 230V, 3PH			3	3									3			
5" 1700 20HP, 440V, 3PH	3	3							3							
5" 1700 30HP, 230V, 3PH			3	3											3	
5" 1700 30HP, 440V, 30PH	3	3									3					
5" 1700 40HP, 230V, 3PH			3	3												3
5" 1700 40HP, 440V, 3PH	3	3											3			
DUAL MOTOR																
2 X 7.5 HP 230V, 1 PH					3	3					6					
2 x 10 HP 230V, 1 PH					3	3						6				
2 x 15 HP 230V, 1 PH					3	3								6		

9. WIRING

Standard Schematic With Digital Amp Meter

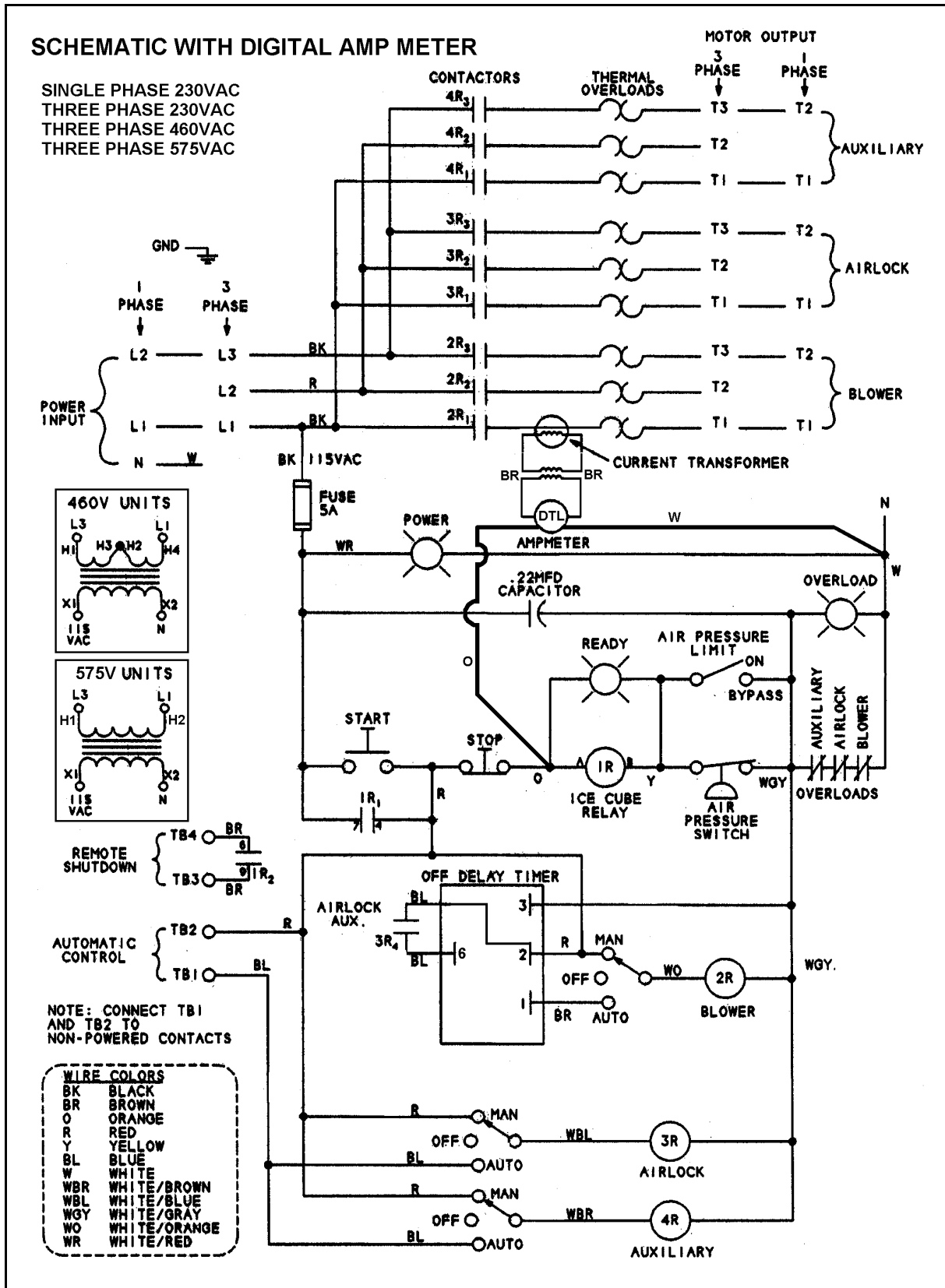

Standard Schematic With Analog Amp Meter Using 2EL0273 Control Relay

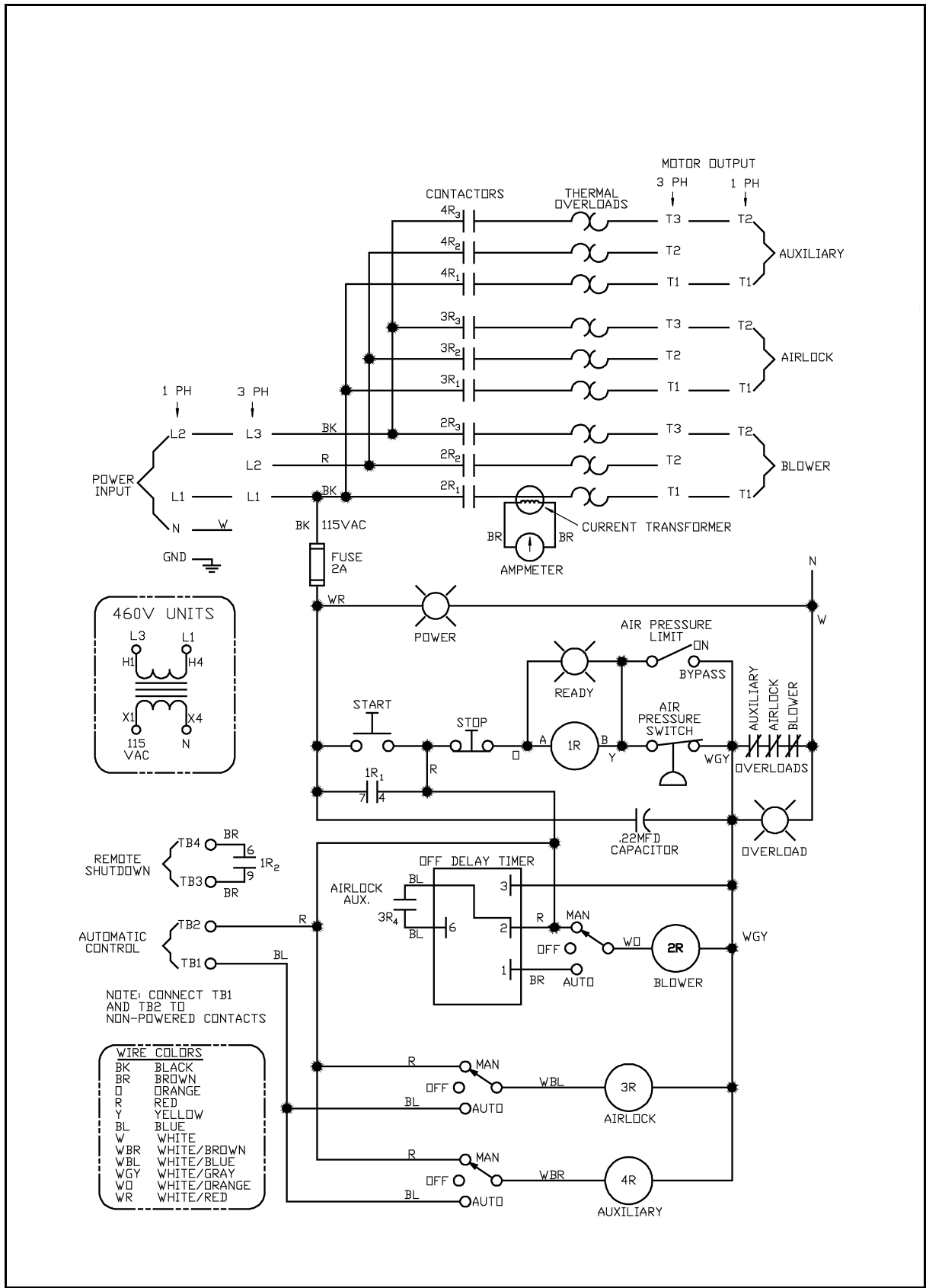

9. WIRING

Schematic With Analog Amp Meter Using HF-7203 Control Relay

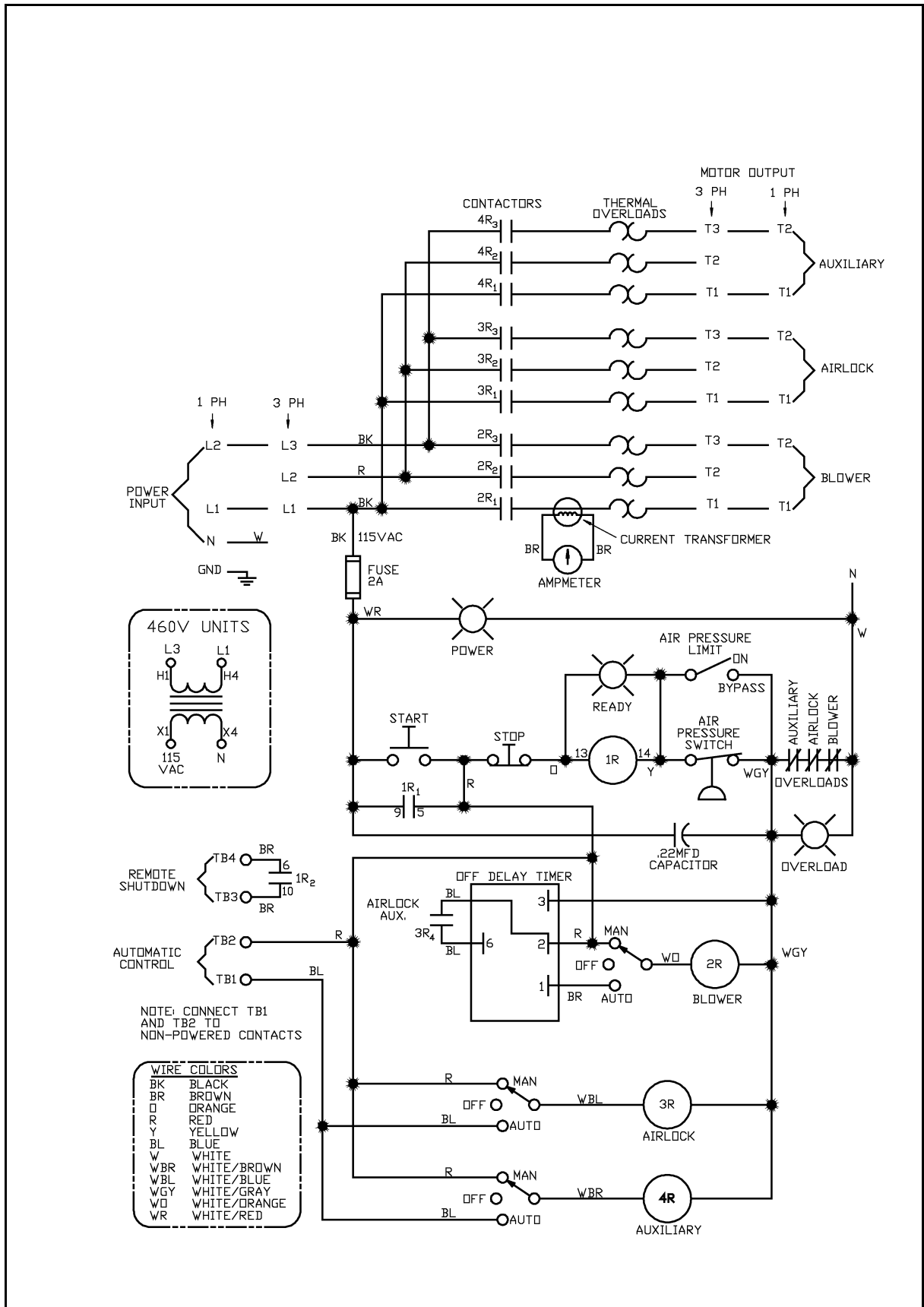

Twin Schematic With Digital Amp Meter

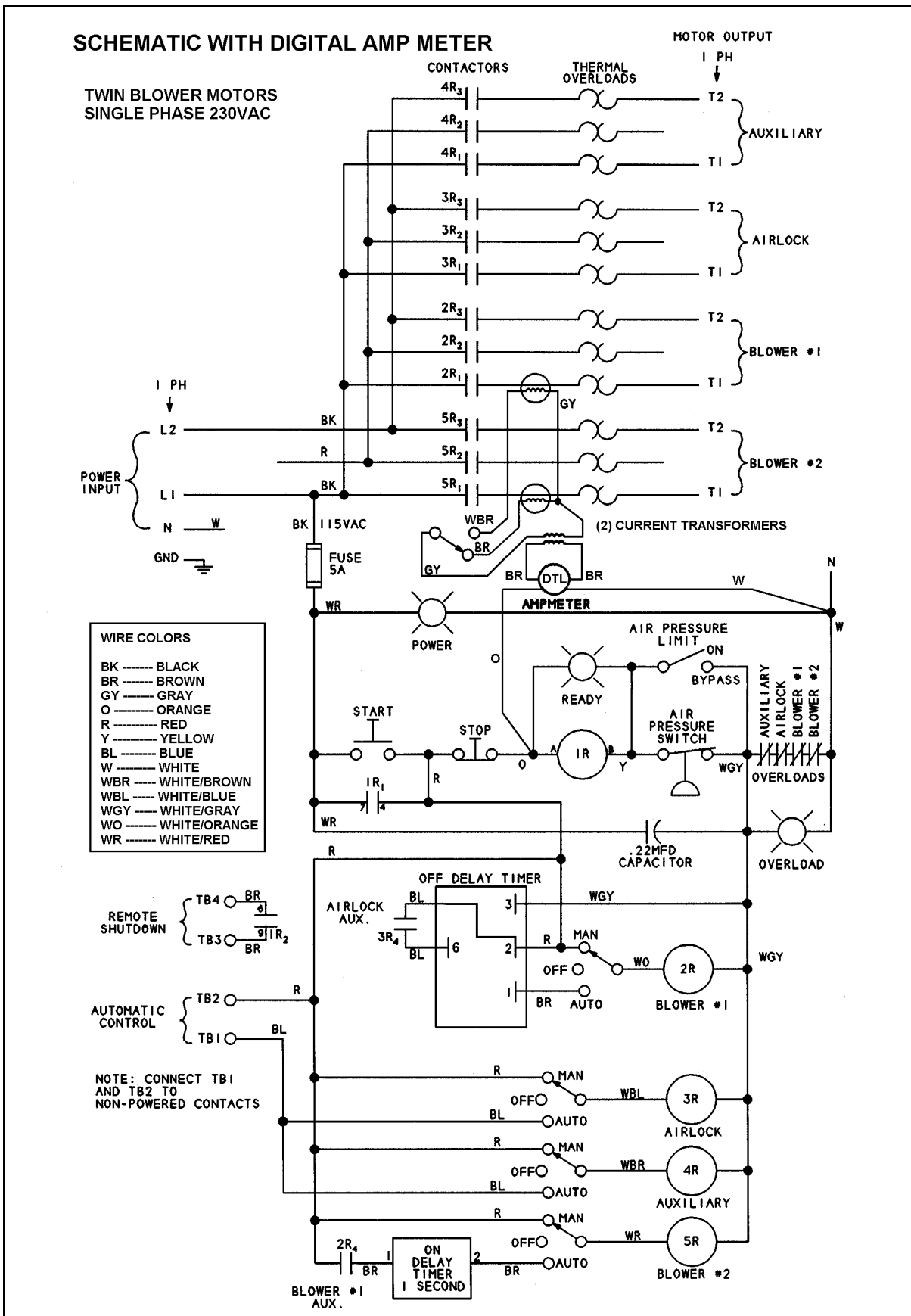

9. WIRING

Twin Schematic With Analog Amp Meter Using 2EL0273 Control Relay

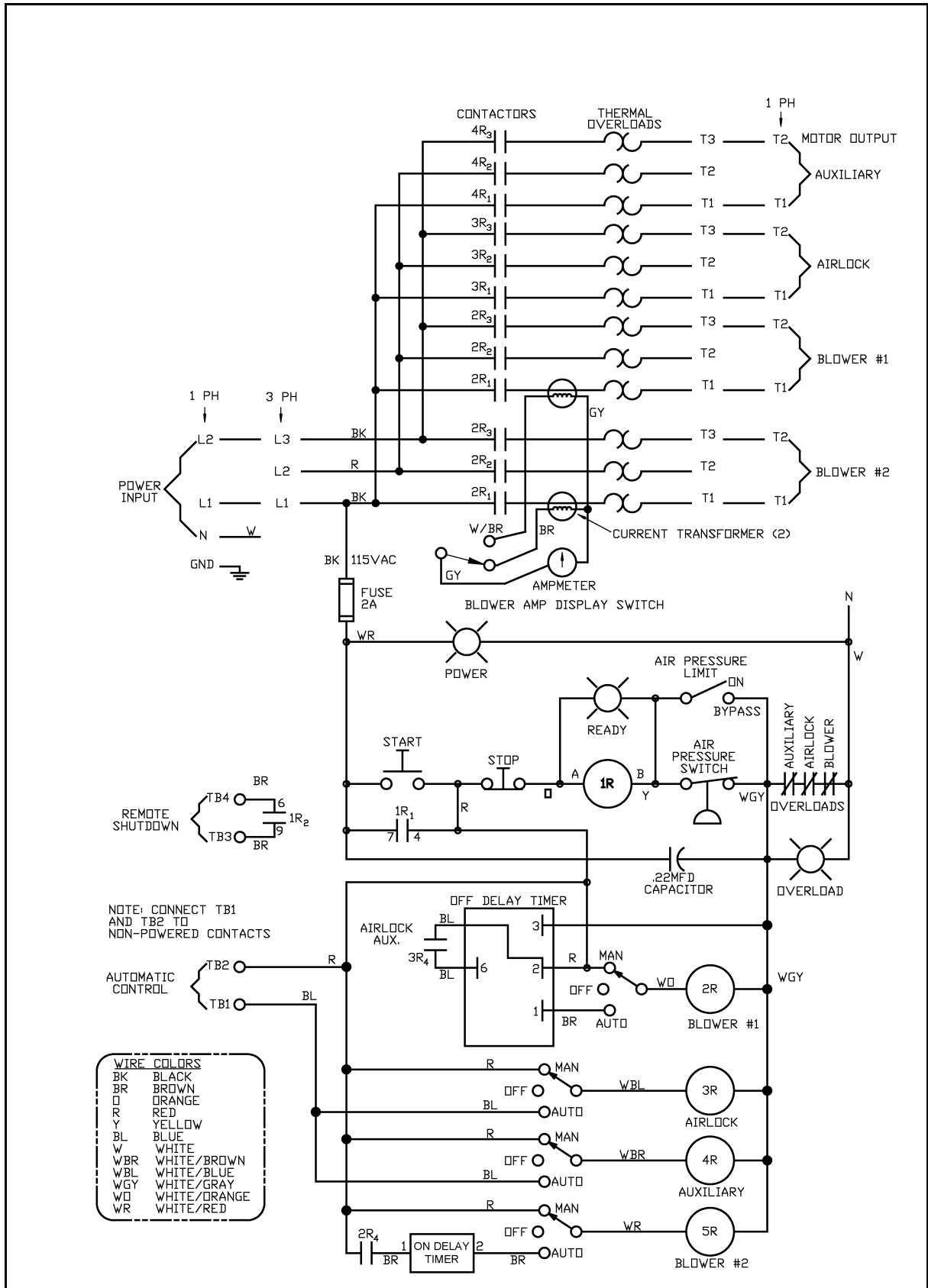

Twin Schematic With Analog Amp Meter Using HF-7203 Control Relay

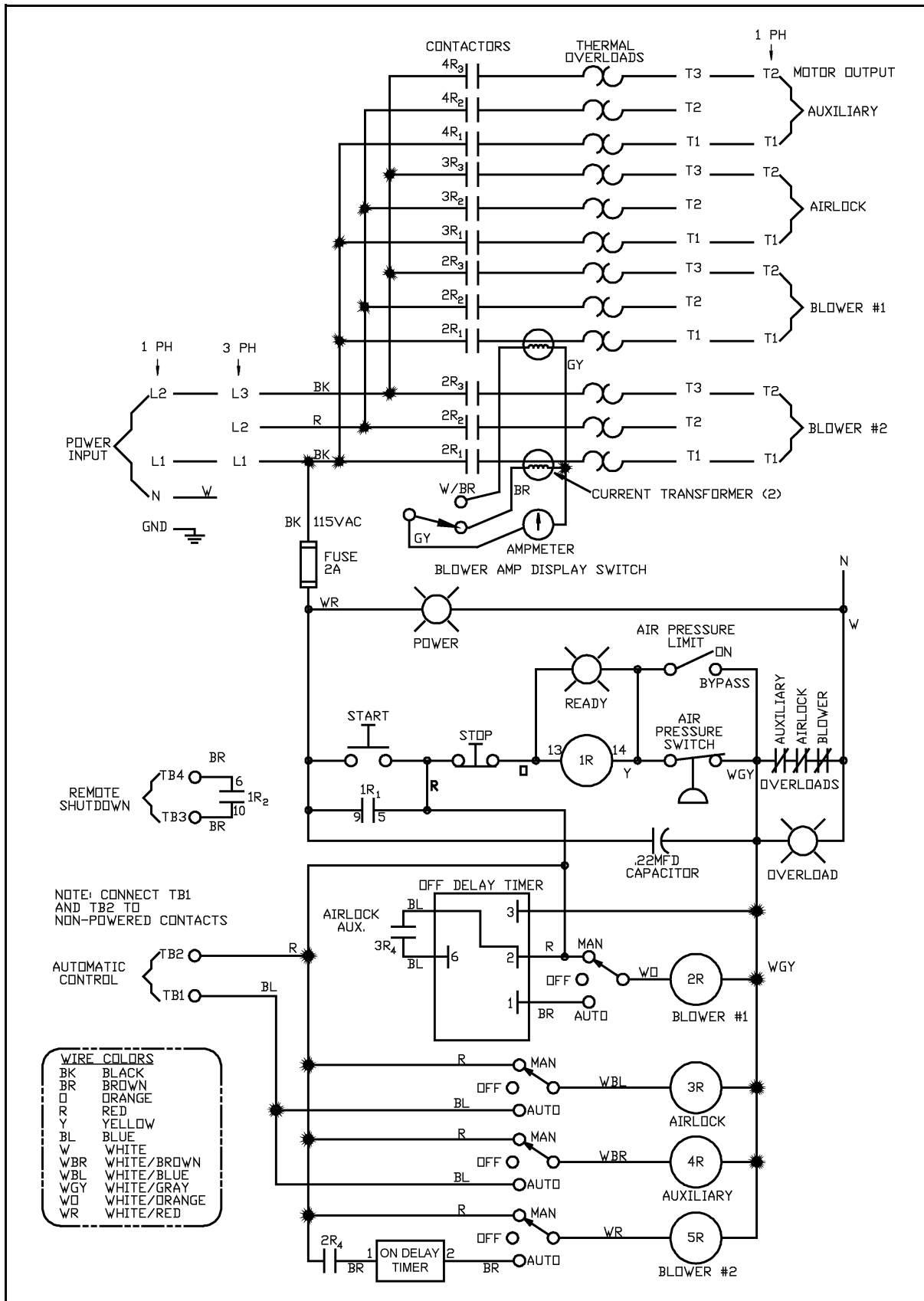

10. OPERATION AND MANAGEMENT

Control Box Operational Procedures

Automatic operation using the Automatic Controller Unit tied to terminals one (1) and two (2).

1. Place the Blower, Airlock and Auxiliary Control Switches in the “Off” position.
2. Place the Air Pressure Limit Control Switch in the “On” position (unit will stop when the air pressure reaches 10 PSI).
3. Turn on the power to the Air Systems Control Box. The power light should come on.
4. Push the Start button; the Control Circuit Ready Light should come on.
5. Place the Blower, Airlock and Auxiliary Switch in the “Auto” position.
6. The complete air system will now run when the Automatic Controller completes the circuit between terminals one (1) and two (2). When this circuit is broken, the airlock and auxiliary equipment will stop immediately, but the blower will continue to run for an additional 15 seconds to clear the tubing in the system.
7. The airlock, auxiliary equipment, and blower will run when the control switches are placed in the “manual” mode. The airlock, auxiliary equipment and blower will stop immediately when switched “off”.
8. Pushing the Stop button will immediately stop all air system functions as well as any equipment tied to terminals three (3) and four (4).

Operation of the air system WITHOUT an Automatic Controller tied to terminals one (1) and two (2).

1. Place the Blower, Airlock and Auxiliary Control Switches in the “Off” position.
2. Place the Air Pressure Limit Control Switch in the “On” position (unit will stop when the air pressure reaches 10 PSI).
3. Turn on the power to the Air System Control Box; the power light should come on.
4. Push the Start button. The Control Circuit Ready Light should come on.
5. The blower, airlock and auxiliary equipment can now be run by placing them in the “manual” position. The airlock, auxiliary equipment and blower will stop immediately when switched off.
6. Pushing the stop button will immediately stop all air system functions as well as any remote equipment tied to terminals three (3) and four (4).

10. OPERATION AND MANAGEMENT

Air System Operation Guidelines

1. Be aware of the quality of grain that is entering and leaving the air system. Grain damage can occur with any pneumatic system unless care is taken to adjust the velocity of the grain. This can be done by opening or closing the outlet gate valve on the blower outlet of the air system. Opening the valve will let air out of the tubing system which will slow the velocity of the air and grain in the tubing system. A recommended procedure is to open the valve slowly until the line pressure begins to surge and then to close it by 1/2 turn. This will provide the slowest possible grain velocity for any tubing system. This procedure for adjusting the air velocity should be repeated for each different tubing layout and capacity change.
2. If the tubing system should become plugged, place the air pressure limit switch to the "Off" position, switch the airlock and auxiliary equipment to "Off" and the blower to "Manual". Note the opening of the outlet gate valve, then open it completely so all the air is exhausted when the blower is started. Push the start button and the blower will start. Slowly close the outlet gate valve until the grain starts moving and clears the tube. Adjust the valve as explained in [Step - 1](#). It should be the same as noted before adjusting. Operate the airlock and auxiliary equipment in "Manual" until all grain is out of the system.

⚠ CAUTION ⚠

Do not stand next to the exhausted air.

3. The air pressure limit switch should always be in the "On" position during routine operation to provide protection to the blower against overload conditions. The air pressure limit is set at the factory to shut down the system at 10 p.s.i. If adjustment is needed, rotate the adjusting screw counterclockwise to lower the pressure limit, or clockwise to increase the pressure limit. A one-half (1/2) turn of the screw will change the pressure limit one (1) p.s.i.

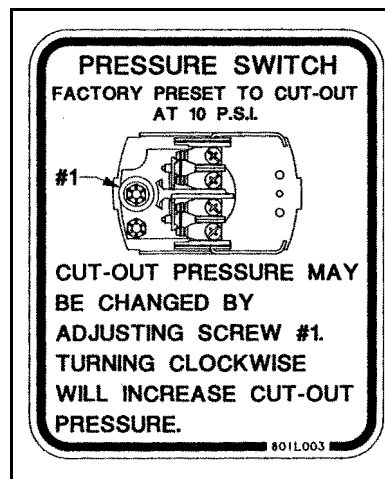

Figure 10A

Note: If the pressure limit is set below five (5) p.s.i., the switch may not reset and allow the air transfer to run. (See [Figure 10A](#)).

10. OPERATION AND MANAGEMENT

4. The air filter element should be inspected daily and cleaned when required. Both the poly foam pre-filter and the filter element can be cleaned by blowing air through them or washing them with mild detergent and water. A restricted air filter will cause a system to become plugged. It should always be inspected whenever plugging occurs.
5. The airlock is provided with a housing that incorporates grain shear protection to prevent grain damage.

6. GUIDELINES FOR OPERATION OF AIR SYSTEMS

- a. Grain in a pneumatic air system running at full capacity will move at about 60% of the air speed. A system operating at low capacities will move grain at 80-90% of the air speed.
- b. Decreasing the amount of air in the system (opening the hand gate valve) will cause the grain to move slower and also cause the air pressure to rise. (Essentially, the grain is causing the air to “pile up”).
- c. Increasing the air in a system (closing the gate valve) will increase the grain velocity and lower the pressure.
- d. TYPICAL RUNNING CONDITIONS ARE:
 - A 4” system running full with 15 HP will have a system pressure of 4-5 psi.
 - A 5” system running full with 30 HP will have a system pressure of 5-6 psi.
 - A 5” system running full with 40 HP will have a system pressure of 6-7 psi.

7. OPERATION OF TWIN MOTOR TRANSFER OPTION

The Twin Motor Option allows an air system to use two single phase motors to provide extra power when 3 phase electricity is not available.

The Twin Motor Control box is different from the standard control box because it has an additional magnetic contactor and an “On-Delay” timer for stagger starting the second motor to minimize voltage drop during the starting operation. It also has a selection switch to display the amperage of each motor.

It is important to use two motors of similar model and size because it is normal for motors to run at slightly different amperages and for one to be more heavily loaded than the other. Using similar motors will minimize this condition.

Check the amperage of each motor periodically by using the selection switch on the control panel. Leave the switch in position to monitor the motor with the highest amperage. It is important to periodically check both motor amperages to insure that they are sharing the load. For example, if the belts for one motor would start to slip, then the other motor would take on the additional load and become overloaded.

Note: Twin Drive capacities are approximately 80% of Single Drive Units.

10. OPERATION AND MANAGEMENT

8. RECOMMENDATIONS FOR OFF-SEASON STORAGE

The blower and airlock have precision machined components and must be protected to prevent corrosion and rust from forming on the blower lobes and airlock vanes. These parts should be coated with motor oil after each drying season. (Spray lubricants such as WD-40 do not usually provide adequate protection.)

Both the airlock and blower assemblies should be carefully protected from the weather and the piping system disconnected from the blower and airlock. Remove the transition connection to the airlock inlet and re-install the weather cover shipped with the airlock. This is important to prevent condensation from collecting in the airlock and blower.

11. HOOK-UP DIAGRAMS

WIRING FOR A SURGE TANK HOOKED TO A TRANS-FER

The Air System will start when both P1 and P2 are closed. As it empties, P1 will open but will not stop the unit due to 4R4 being closed. When P2 opens, the unit will stop.

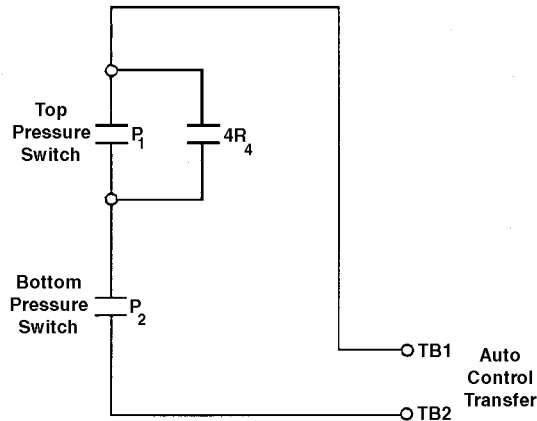

P1 and P2 are Pressure Switches.
4R4 is an Auxiliary Switch (2EL0648) attached to the Top Contactor 4R4.

HOW TO HOOK UP AIR SYSTEM TO REMOTE EQUIPMENT

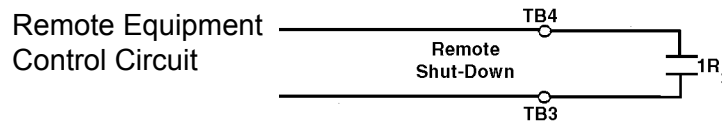

Any contact that closes upon start and opens on stop. (Note: This contact must not have any external AC Power)

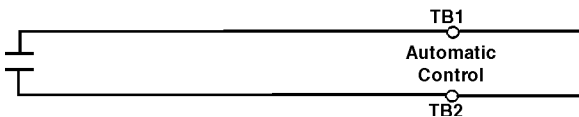

With the above hook up, the Air System must be started before the remote equipment. If the Air System is manually turned off or turned off from high pressure or an overload, the remote equipment will also turn off.

TB3 and TB4 will have a closed contact (1R2) as long as the air system has the "ready" indicator (located in the control box) on. The automatic control TB1 and TB2 requires a closed contact across them to start the air system unit.

1. 4" (700) & 5" (1200) Standard Blower Parts
2. 4" & 5" Twin Blower Parts
3. 5" (1700) Hi-Capacity Blower Parts
4. 5" (1700) Twin Hi-Capacity Blower Parts
5. 4" & 5" Blower Filters
6. 4" & 5" Airlock Parts
7. Airlock Inlet Transition Assembly
8. Panel Module Assembly - Digital
9. Panel Module Assembly - Analog
10. Switch Panel Assembly - Standard
11. Switch Panel Assembly - Twin
12. Standard Control Panel Assembly - 230 V 10-30 HP
13. Standard Control Panel Assembly - 230 V 10-30 HP Used In 8015071 Control Box (CSA Listed)
14. Standard Control Panel Assembly - 230 V 40 HP
15. Twin Control Panel Assembly - 230 V 7-15 HP
16. Twin Control Panel Assembly - 230 V 7-15 HP Used in 8015114 Control Box (CSA Listed)
17. Standard Control Panel Assembly - 460 V 10 - 40 HP
18. Control Panel Assembly - 460 V 10-40 HP Used In 8015072 Control Box (CSA Listed)

12. PARTS LIST

4" (700) & 5" (1200) Standard Blower Parts

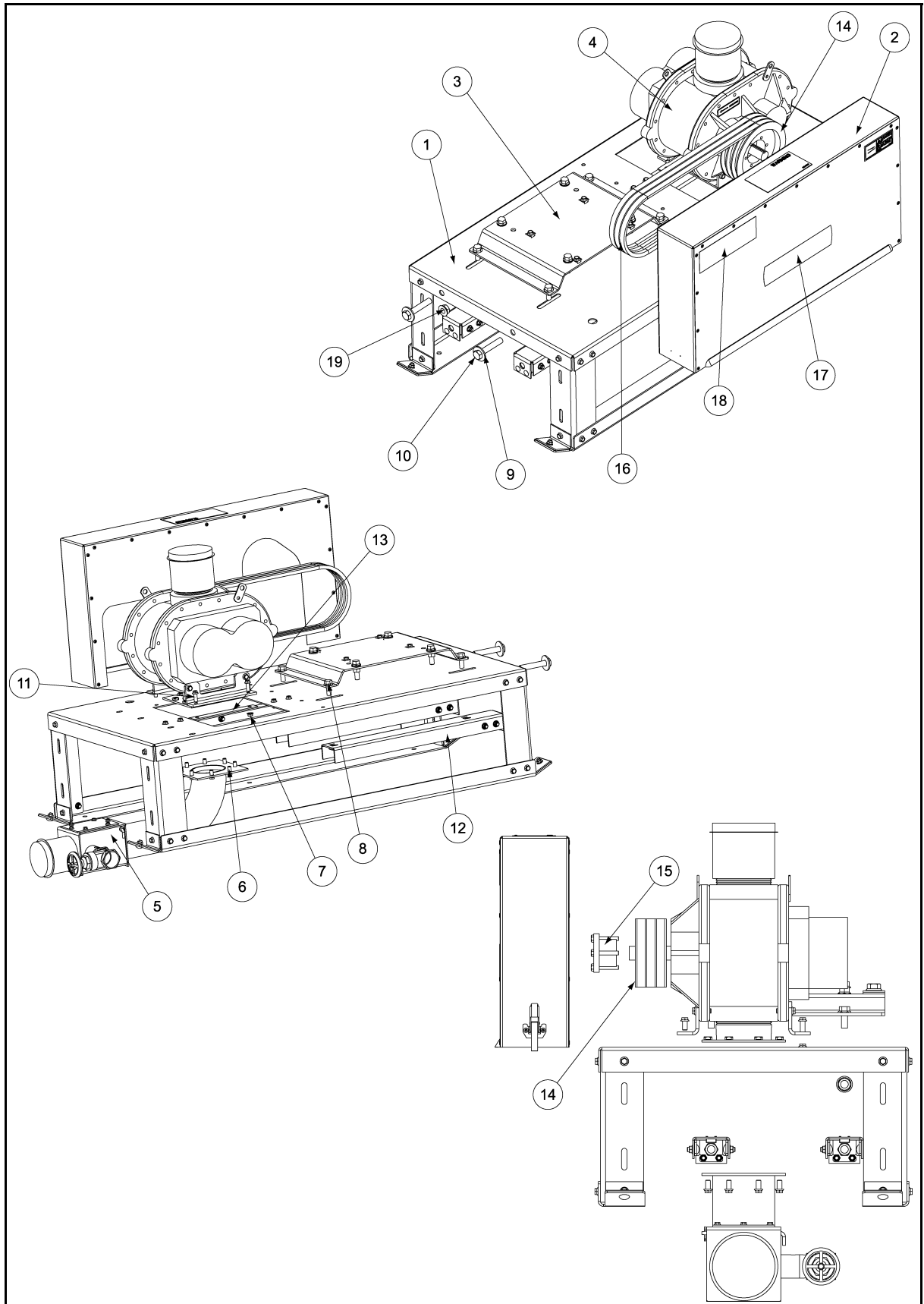

4" (700) & 5" (1200) Standard Blower Parts

Ref #	Part #	4" Qty	5" Qty	Description
1	AS-0003	1	1	Blower Base Asy 4" & 5"
2	AS-0108	1	1	Drv Guard Asy-4"& 5" STD Blower
3	AS-0047	1	-	Motor MTG Plate Asy-4" Air Sys
3	AS-0058	-	1	Motor MTG Plate Asy-5" Air Sys
4	8011266	1	1	Blower Sub-asy-4" & 5" STD DMC
	8011266F	1	1	Blower Sub-asy-4" & 5" STD FFI
5	AS-0088-D	1	-	Blower Outlet Elbow Asy-4" DMC
	AS-0088-F	1	-	Blower Outlet Elbow Asy-4" FFI
	AS-0092-D	-	1	Blower Outlet Elbow Asy-5" DMC
	AS-0092-F	-	1	Blower Outlet Elbow Asy-5" FFI
6	S-9067	14	14	Bolt Flngs 3/8-16 x 3/4 Zn GR5
7	S-968	8	8	Nut Flangwz 3/8-16 Zn GR5
8	S-9062	4	4	Bolt Flngs 1/2-13 x 1-1/4 Zn GR5
9	S-858	2	2	Washer Flat 5/8 Uss Zn
10	2FH1043	2	2	Bolt 5/8-11 x 3-1/2 HHTB GR2 PLT
11	S-9065	2	2	Bolt Flngs 3/8-16 x 1 Zn GR5
12	AS-0025	2	2	Motor Adjust Rail Asy
13	AS-0042	1	1	Blower Suppt/shim Asy-4" & 5"
14	PT0664	1	-	Pulley Qd 7.75OD x Sk Bush 3AB
	PT0602	-	1	Pulley-(Solid)5.50"Od x SD 3AB
15	PT0772	1	-	Bushing-QD Style Sk,1-1/8" Bore
	PT0794	-	1	Bushing-SD X 1-1/8 Bore
16	MHC00028	3	-	Belt-V B x 60
	PT1179	-	3	Belt-V B x 58
17	801L001	1	-	Logo Decal-Transfer 700
	8027012	-	1	Logo Decal-Transfer 1200
	420-1443-1	1	1	Logo Decal -FFI
18	DC-1330	1	1	Logo Decal- MC 2-7/8 x 9
19	S-9259	1	1	Nut Flangwz 5/8-11 Zn
-	PT1132	1	1	Gate Valve-1-1/2" NPT

4" (700) & 5" (1200) Standard Blower Parts

MOTORS & DRIVE PARTS (NOT SHOWN)				
Ref #	Part #	4" Qty	5" Qty	Description
	PT0666	x	x	Pulley QD 8.95OD x SK Bush 3AB
	MHC60010-1	x	x	Motor 10 HP 1 PH 1800 RPM
	1000-3	x	x	Motor 10 HP 3 PH 1800 RPM
	PT0778	x	x	Bushing SK 1-3/8" Bore QD Style
	CH-5753	x	x	Motor 15 HP 1 PH 1800 RPM ODP
	3EL5069	x	x	Motor 15 HP 1 PH 1800 RPM TEFC
	1500-3	x	x	Motor 15 HP 3 PH 1800 RPM
	2000-3	x	x	Motor 20 HP 3 PH 1800 RPM
	GC03810	x	x	Bushing SK 1-5/8" Bore QD Style
	3000-3	-	x	Motor 30 HP 3 PH 1800 RPM
	CE-00617	-	x	Bushing SK 1-7/8" Bore QD Style

12. PARTS LIST

4" & 5" Twin Blower Parts

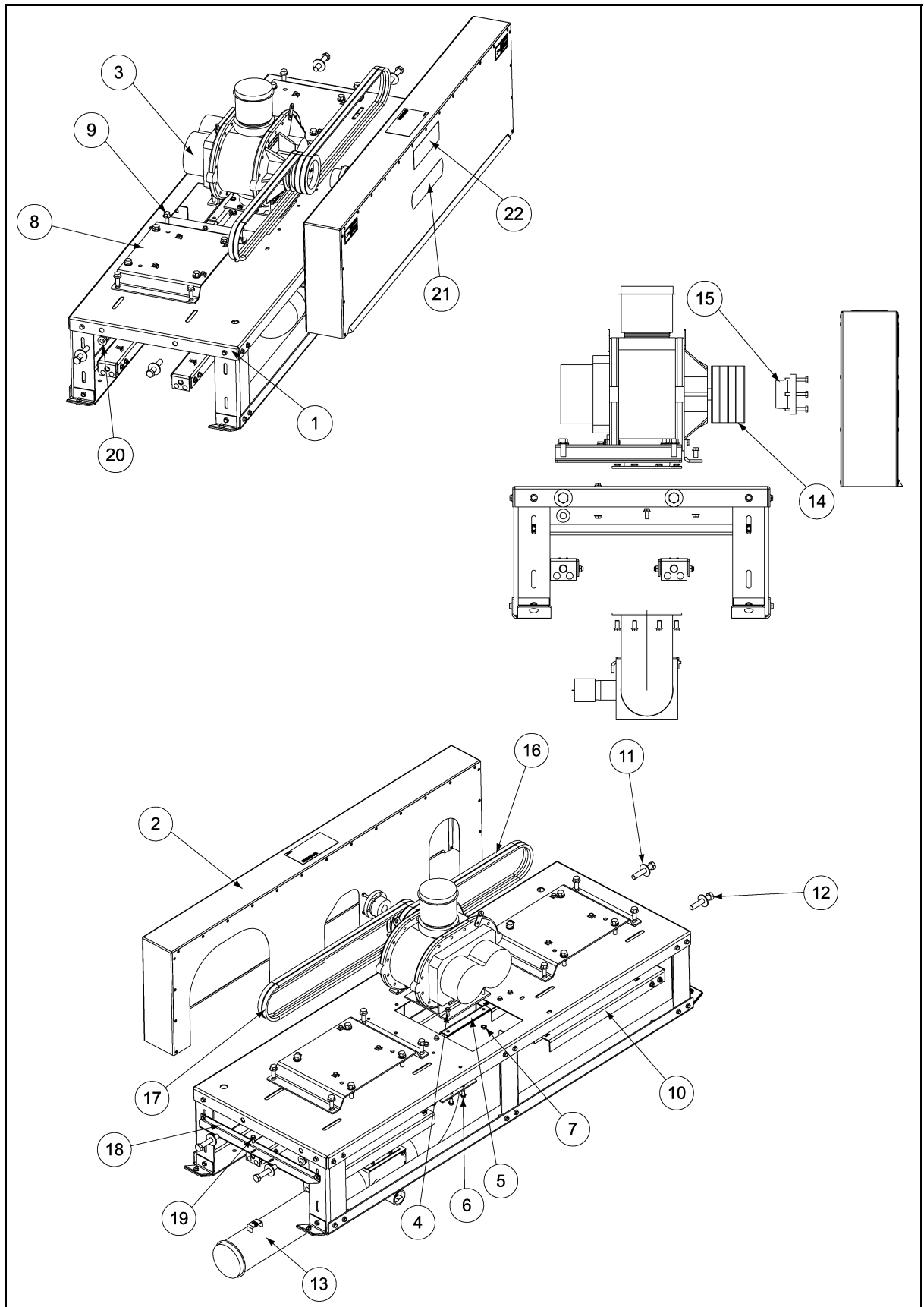

4" & 5" Twin Blower Parts

Ref #	Part #	4" Qty	5" Qty	Description
1	AS-0007	1	1	Blower Base Asy 4" & 5" Twin
2	AS-0110	1	1	Drv Guard Asy-4"& 5" TWN Blower
3	8011266	1	1	Blower Sub-asy-4" & 5" Std DMC
3	8011266F	1	1	Blower Sub-asy-4" & 5" Std FFI
4	S-9065	2	2	Bolt Flngs 3/8-16 x 1 Zn GR5
5	AS-0042	1	1	Blower SUPPT/SHIM Asy-4" & 5"
6	S-9067	16	16	Bolt Flngs 3/8-16 x 3/4 Zn GR5
7	S-968	10	10	Nut Flangwz 3/8-16 Zn GR5
8	AS-0047	2	2	Motor MTG Plate Asy-4" Air Sys
9	S-9062	8	8	Bolt Flngs 1/2-13 x 1-1/4 Zn Gr5
10	AS-0025	4	4	Motor Adjust Rail Asy
11	S-858	4	4	Washer Flat 5/8 Uss Zn
12	2FH1043	4	4	Bolt 5/8-11 x 3-1/2 HHTB GR2 PLT
13	AS-0048-D	1	-	Elbow Asy-blower 4" STD Twin DMC
	AS-0048-F	1	-	Elbow Asy-blower 4" STD Twin FFI
	AS-0054-D	-	1	Elbow Asy-blower 5" STD Twin DMC
	AS-0054-F	-	1	Elbow Asy-blower 5" STD Twin FFI
14	PT0742	1	-	Pulley QD 7.75OD x Sk Bush 4AB
	PT0741	-	1	Pulley-5.50OD x SD BSH 4AB
15	PT0772	1	-	Bushing-qd Style Sk, 1-1/8"Bore
	PT0794	-	1	Bushing-Sd X 1-1/8 Bore
16	MHC00028	-	2	Belt-V B x 60
	MHC00743	2	-	Belt-V B x 65
17	MHC00020	2	-	Belt-V B x 68
	MHC00743	-	2	Belt-V B x 65
18	AS-0085	1	1	Support Angle-blower Outlet TW
19	S-6606	1	1	Bolt Flngs 5/16-18 x 3/4 Zn Gr5
20	S-9259	2	2	Nut Flangwz 5/8-11 Zn
21	8027012	1	1	Logo Decal-Transfer 1200
	420-1443-1	1	1	Logo Decal-FFI
22	DC-1330	1	1	Logo Decal-DMC 2-7/8 x 9
-	AS-0112	1	1	Air Sys-gate Valve Asy-Twin

4" & 5" Twin Blower Parts

MOTORS & DRIVE PARTS (NOT SHOWN)				
Ref #	Part #	4" Qty	5" Qty	Description
	PT0749	x	x	Pulley QD 8.95OD x SK Bush 2AB
	002-1054-2	x	-	Motor 7.5 HP 1PH 1800 RPM
	PT0772	x	-	Bushing Sk 1-1/8" Bore QD Style
	MHC60010-1	x	x	Motor 10 HP 1PH 1800 RPM
	PT0778	x	x	Bushing SK 1-3/8" Bore QD Style
	CH-5753	-	x	Motor 15 HP 1PH 1800 RPM ODP
	3EL5069	-	x	Motor 15 HP 1PH 1800 RPM TEFC
	GC03810	-	x	Bushing SK 1-5/8" Bore QD Style

12. PARTS LIST

5" (1700) Hi-Capacity Blower Parts

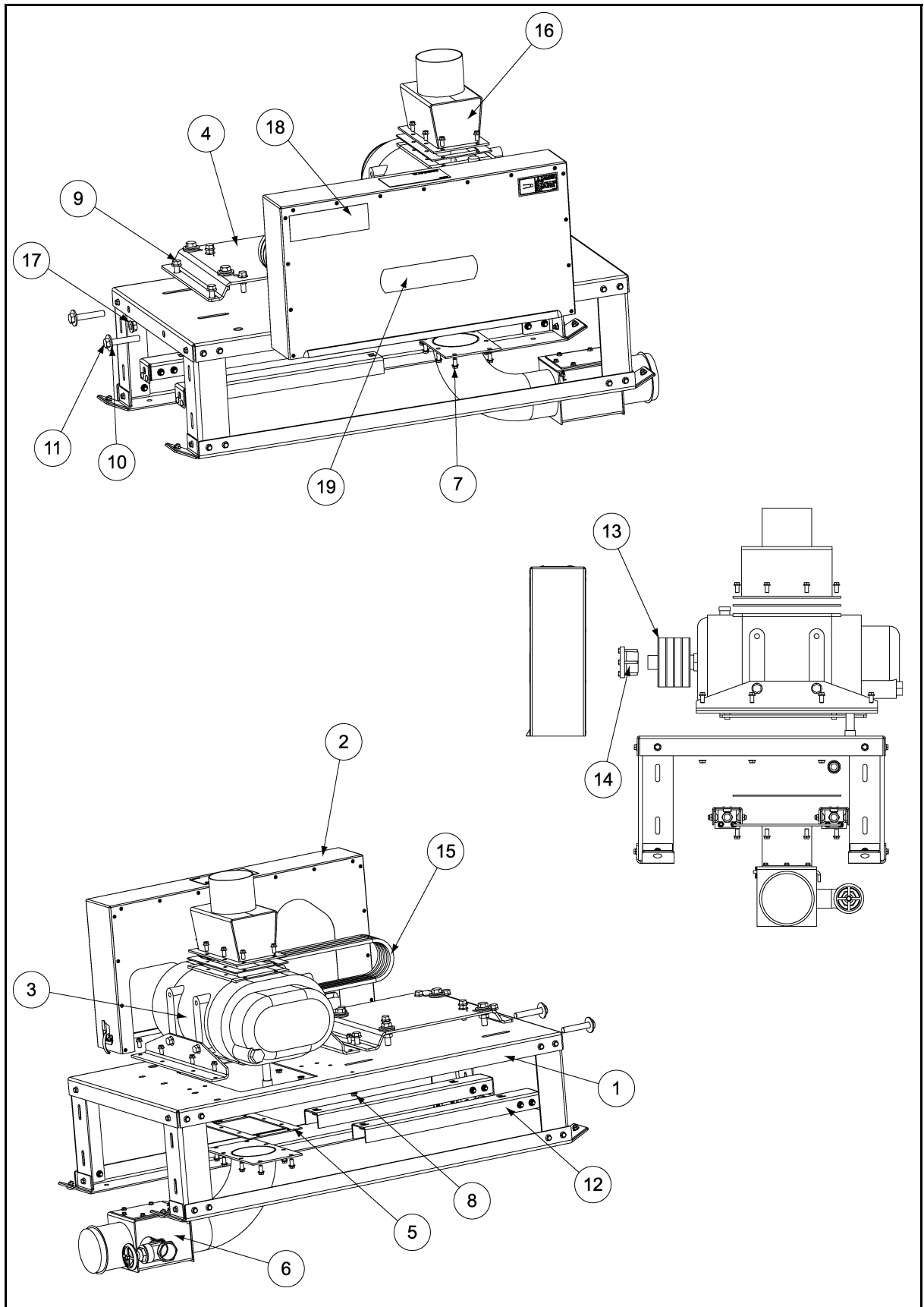

5" (1700) Hi-Capacity Blower Parts

Ref #	Part #	Qty	Description
1	AS-0003	1	Blower Base Asy 4" & 5"
2	AS-0108	1	DRV Guard Asy-4"& 5" STD Blower
3	CA-1059	1	Blower Sub-asy -5" HICAP DMC
	CA-1059F	1	Blower Sub-asy-5" HICAP FFI
4	AS-0058	1	Motor Mtg Plate Asy-5" Air Sys
5	802B006	2	Blower Gasket-5" Hi Capacity
6	AS-0094-D	1	Blower Outlet Elb Asy-5" HICAP DMC
	AS-0094-F	1	Blower Outlet Elb Asy-5" HICAP FFI
7	S-9067	24	Bolt Flngs 3/8-16 x 3/4 Zn GR5
8	S-968	8	Nut Flangwz 3/8-16 Zn GR5
9	S-9062	4	Bolt Flngs 1/2-13x1-1/4 Zn GR5
10	S-858	2	Washer Flat 5/8 Uss Zn
11	2FH1043	2	Bolt 5/8-11 x 3-1/2 HHTB GR2 PLT
12	AS-0025	2	Motor Adjust Rail Asy
13	PT0736	1	Pulley-4.95" OD x SD BSH 4AB
14	GC06682	1	Bushing SD X 1-7/16" Bore
15	MHC00028	4	Belt-V B x 60
16	8021130-RD	1	Blower Inlet-5" HI-RED
	8021130-OR	1	Blower Inlet-5" HI-ORANGE
17	S-9259	1	Nut Flangwz 5/8-11 Zn
18	DC-1330	1	Logo Decal-DMC 2-7/8 X 9
19	420-1443-1	1	Logo Decal-FFI
	8027011	1	Logo Decal-Transfer 1700
-	PT1132	1	Gate Valve -1-1/2" NPT

5" (1700) Hi-Capacity Blower Parts

MOTORS & DRIVE PARTS (NOT SHOWN)			
Ref #	Part #	Qty	Description
	PT0737	x	Pulley QD 8.95 Od x SK Bush 4AB
	2000-3	x	Motor 20 HP 3 PH 1800 RPM
	GC03810	x	Bushing SK 1-5/8" Bore QD Style
	3000-3	x	Motor 30 HP 3 PH 1800 RPM
	CE-00617	x	Bushing SK 1-7/8" Bore QD Style
	4000-3	x	Motor 40 HP 3PH 1800 RPM
	PT0784	x	Bushing SK 2-1/8" Bore QD Style

12. PARTS LIST

5" (1700) Twin Hi-Capacity Blower Parts

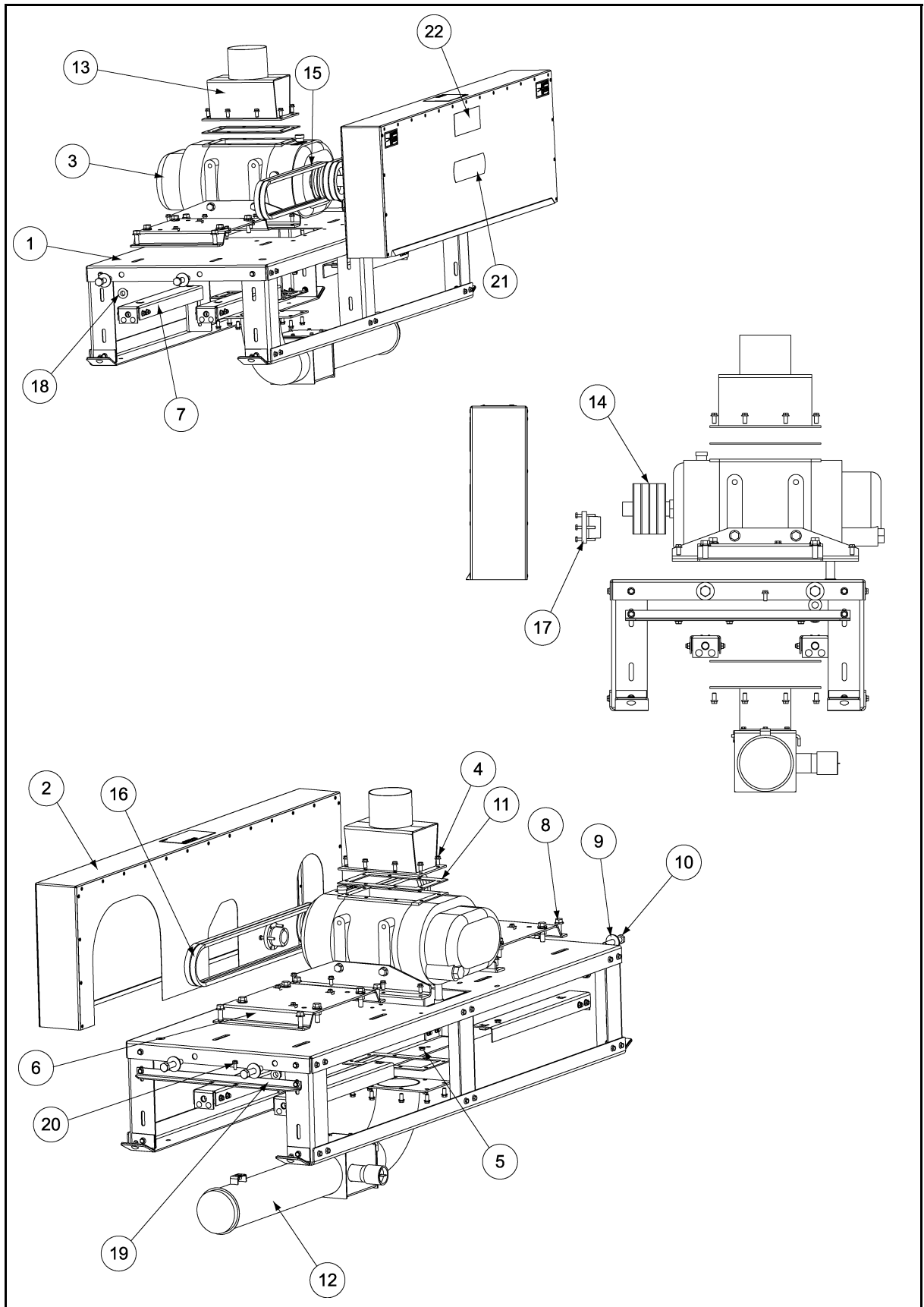

5" (1700) Twin Hi-Capacity Blower Parts

Ref #	Part #	Qty	Description
1	AS-0007	1	Blower Base Asy 4" & 5" Twin
2	AS-0110	1	DRV Guard Asy-4"& 5" Twn Blower
3	CA-1059	1	Blower Sub-asy -5" HICAP DMC
3	CA-1059F	1	Blower Sub-asy -5" HICAP FFI
4	S-9067	26	Bolt Flngs 3/8-16 x 3/4 Zn GR5
5	S-968	10	Nut Flangwz 3/8-16 Zn GR5
6	AS-0047	2	Motor Mtg Plate Asy-4" Air Sys
7	AS-0025	4	Motor Adjust Rail Asy
8	S-9062	8	Bolt Flngs 1/2-13 x 1-1/4 Zn GR5
9	S-858	4	Washer Flat 5/8 Uss Zn
10	2FH1043	4	Bolt 5/8-11 x 3-1/2 HHTB GR2 PLT
11	802B006	2	Blower Gasket-5" HI Capacity
12	AS-0051-D	1	Elbow Asy-blower Out 5" HI Twin DMC
	AS-0051-F	1	Elbow Asy-blower Out 5" HI Twin FFI
13	8021130-RD	1	Blower Inlet -5" HI-RED
	8021130-OR	1	Blower Inlet -5" HI-ORANGE
14	PT0736	1	Pulley-4.95" OD x SD BSH 4AB
15	MHC00028	2	Belt-V B x 60
16	MHC00743	2	Belt-V B x 65
17	GC06682	1	Bushing SD x 1-7/16" Bore
18	S-9259	2	Nut Flangwz 5/8-11 Zn
19	AS-0085	1	Support Angle-blower Outlet Twin
20	S-6606	1	Bolt Flngs 5/16-18 x 3/4 Zn GR5
21	8027011	1	Logo Decal-Transfer 1700
	420-1443-1	1	Logo Decal-FFI
22	DC-1330	1	Logo Decal-DMC 2-7/8 X 9
-	AS-0112	1	Air Sys-gate Valve Asy -Twin

5" (1700) Twin Hi-Capacity Blower Parts

MOTORS & DRIVE PARTS (NOT SHOWN)			
Ref #	Part #	Qty	Description
	PT0749	x	Pulley QD 8.95 OD x SK Bush 2AB
	MHC60010-1	x	Motor 10 HP 1PH 1800 RPM
	PT0778	x	Bushing SK 1-3/8" Bore QD Style
	CH-5753	x	Motor 15 HP 1PH 1800 RPM ODP
	3EL5069	x	Motor 15 HP 1PH 1800 RPM TEFC
	GC03810	x	Bushing SK 1-5/8" Bore QD Style

12. PARTS LIST

4" & 5" Blower Filters

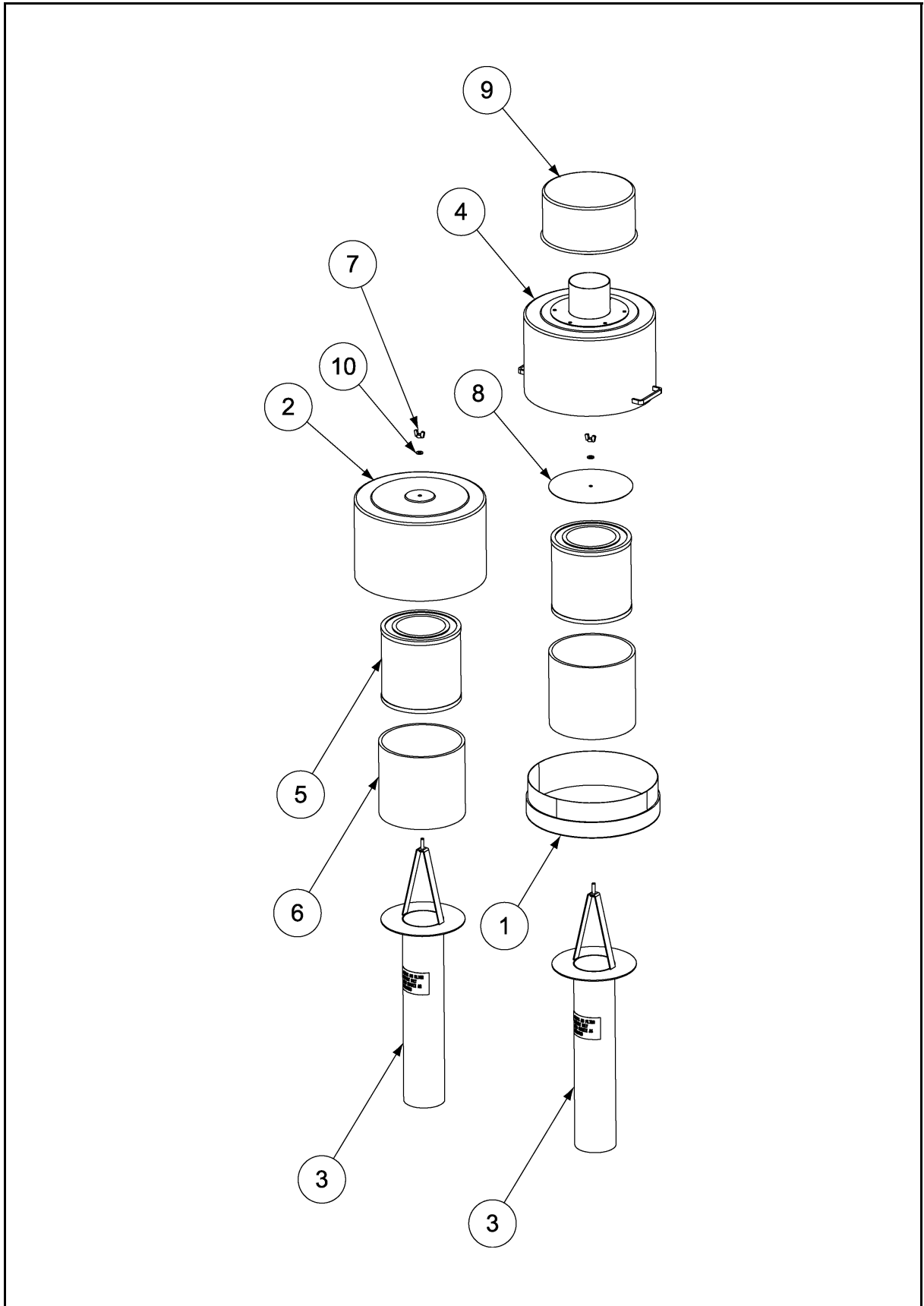

4" & 5" Blower Filters

Ref #	Part #	Qty	Description
1	8021224-RD	1	Base-Prefilter, 5" Weldment-DMC
1	8021224-OR	1	Base-Prefilter, 5" Weldment-FFI
2	801A104-RD	1	Canister- Air Filter -16"-Red
	801A104-OR	1	Canister- Air Filter -16"-Orange
3	802A072-D	1	Filter Base-5 Assembly-DMC
	802A072-F	1	Filter Base-5 Assembly-FFI
4	8021219-D	1	Filter Canister-w/Inlet-Assembly Precleaner-DMC
	8021219-F	1	Filter Canister-w/Inlet-Assembly Precleaner-FFI
5	801A154	1	Filter-Inner, 10 Micron (Part of 801A152)
6	801A156	1	Filter-Outer, (Pre-Foam) (Part of 801A152)
7	S-1451	1	Nut-Wing, 3/8"-16 UNC Plated
8	8021228	1	Plate-Filter Top Precleaner (4" & 5" Air Systems)
9	MS5466	1	Precleaner-5" Inlet Centrifugal (350-700 CFM)
10	S-248	1	Washer-Flat, Standard 3/8", PLTD.

12. PARTS LIST

4" & 5" Airlock Parts

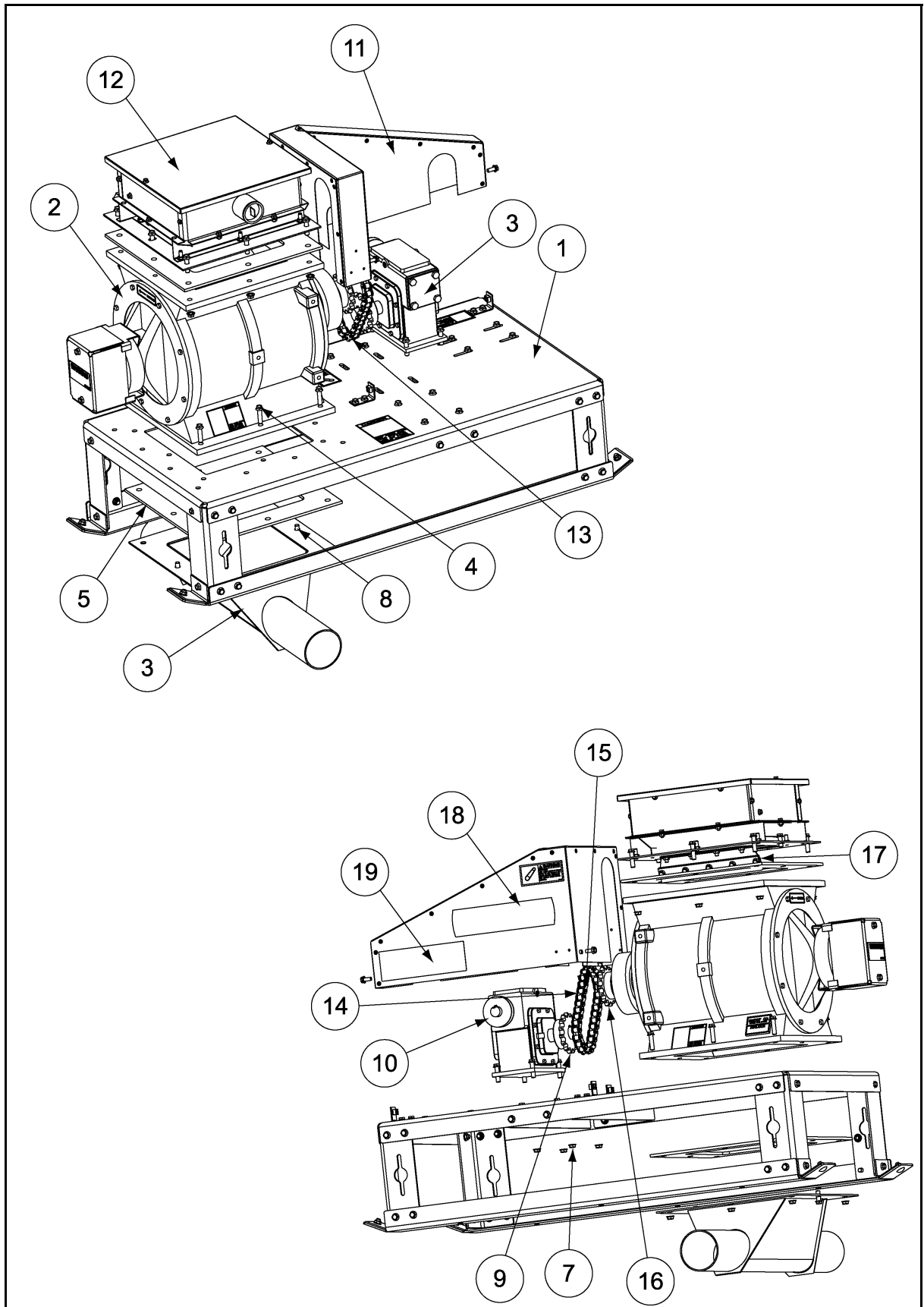

4" & 5" Airlock Parts

Ref #	Part #	4" Qty	5" Qty	Description
	AS-0011	1	1	Airlock Base Asy-4" & 5"
1	AS-0060	1	-	Airlock Sub-asy-4" System DMC
2	AS-0062	-	1	Airlock Sub-asy-5" System DMC
	AS-0060F	1	-	Airlock Sub-asy-4" System FFI
	AS-0062F	-	1	Airlock Sub-asy-5" System FFI
3	AS-0114	1	1	Gearbox Assembly-DMC
	AS-0114F	1	1	Gearbox Assembly-FFI
4	S-9064	16	20	Bolt Flng 3/8-16 x 1-1/2 Zn GR5
5	801C008	2	-	Gasket-4" Airlock
	802C008	-	2	Gasket-5" Airlock
6	AS-0037-RD	1	-	Airlock Hopper Weld-4" Red
	AS-0037-OR	1	-	Airlock Hopper Weld-4" Orange
	AS-0034-RD	-	1	Airlock Hopper Weld-5" Red
	AS-0034-OR	-	1	Airlock Hopper Weld-5" Orange
7	S-968	16	20	Nut Flangwz 3/8-16 Zn GR5
8	S-9065	4	8	Bolt Flngs 3/8-16 x 1 Zn GR5
9	PT1106	1	1	Sprocket- (Hub Type)1-1/4" ID
10	PT0622	1	1	Pulley-(Flat)3." x 1." ID-1A
11	AS-0109	1	1	Airlock Belt Guard Asy-Prior 8/05
	AS-0124	1	1	Airlock Belt Guard Asy-8/05
12	AS-0070	1	-	Inlet Asy-4" Airlock
	AS-0072	-	1	Inlet Asy-5" Airlock
13	801A205	1	-	Chain-roller (4"Airlock)
	801A148	-	1	Chain-roller (5"Airlock)
14	KD-PRC6001	1	1	Link- Connecting, #60 3/4 Pitch
15	PT1054	1	1	Link- Offset, #60 3/4 Pitch
16	PT1083	1	-	Sprocket Hub 15t 1.5" ID #60
	PT1107	-	1	Sprocket- (Hub Type)1-3/4" ID
17	8011293	1	-	Airlock Wiper-shear Protect 4"
	8021209	-	1	Airlock Wiper-shear Protect 5"
18	801L001	1	-	Logo Decal-Transfer 700
	8027013	-	1	Logo Decal-5" Transfer
	420-1507-3	1	1	Logo Decal-ffi
19	DC-1330	1	1	Logo Decal- Dmc 2-7/8 x 9
20	AS-0117	1	1	Air Sys-alk Shaft Guard Asy

4" & 5" Airlock Parts

MOTORS & DRIVE PARTS (NOT SHOWN)				
Ref #	Part #	4" Qty	5" Qty	Description
	100-1	x	x	Motor 1 HP 1P H 56 TEFC 5/8 Shaft
	002-1087-2	x	x	Motor 1 HP 3 PH 56 TEFC 5/8 Shaft
	PT0483	x	x	Belt-V A31-Prior 8/05
	AS-0212	x	x	Belt-V A24-8/05
	PT0618	x	x	Pulley 3.25" OD x .62" ID-1A
	PT0558	-	5" (1700)	Pulley 4.44" OD x .62" ID-1A

12. PARTS LIST

Airlock Inlet Transition Assembly

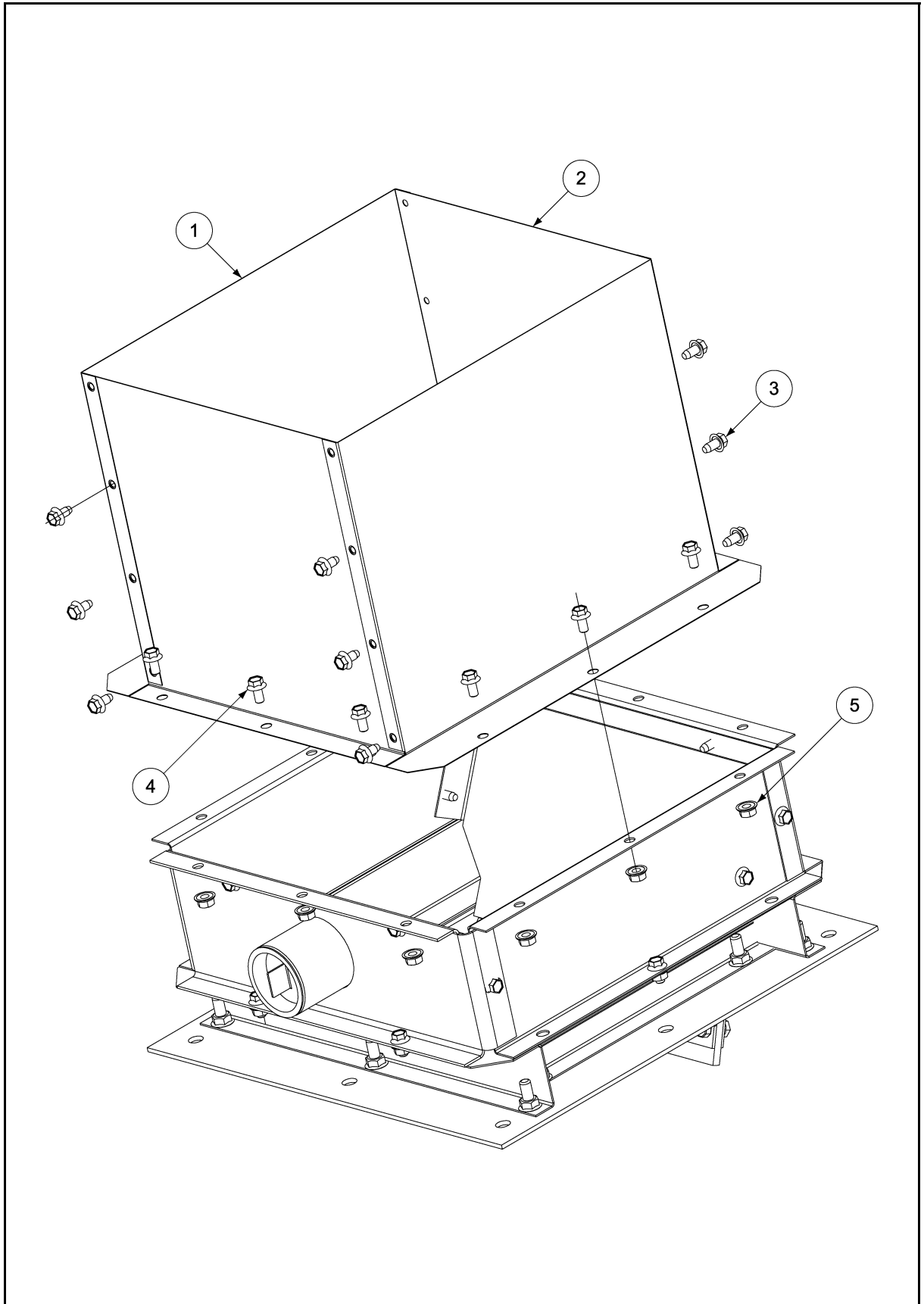

Airlock Inlet Transition Assembly

Ref #	Part #	Qty	Description
1	AS-0077	2	Airlock Inlet Trans-RH & LH
2	AS-0078	2	Airlock Trans-Front & Back
3	S-9028	12	Screw SMSAB 1/4-14 x 1/2 Hwh Zn
4	S-8857	10	Bolt Flngs 1/4-20 x 1/2 Zn GR5
5	S-7215	10	Nut Flangwz 1/4-20 Zinc

INSTALLATION OF AIRLOCK TRANSITION TO DRYER DISCHARGE.

1. Remove the weather cover from the airlock inlet assembly.
2. Assemble (2) AS-0077 (Item 1) And (2) AS-0078 (Item 2) together With S-9028 (Item 3) Self-tapper screws as shown in the diagram.
3. Determine what direction the airlock grain line is to run. orient the transition assembly to correspond with the line direction. attach the transition assembly to the airlock inlet using S-8857 (Item 4) and S-7215 (Item 5).
4. Trim the top of the transition assembly to match the height of the dryer discharge.

12. PARTS LIST

Panel Module Assembly - Digital

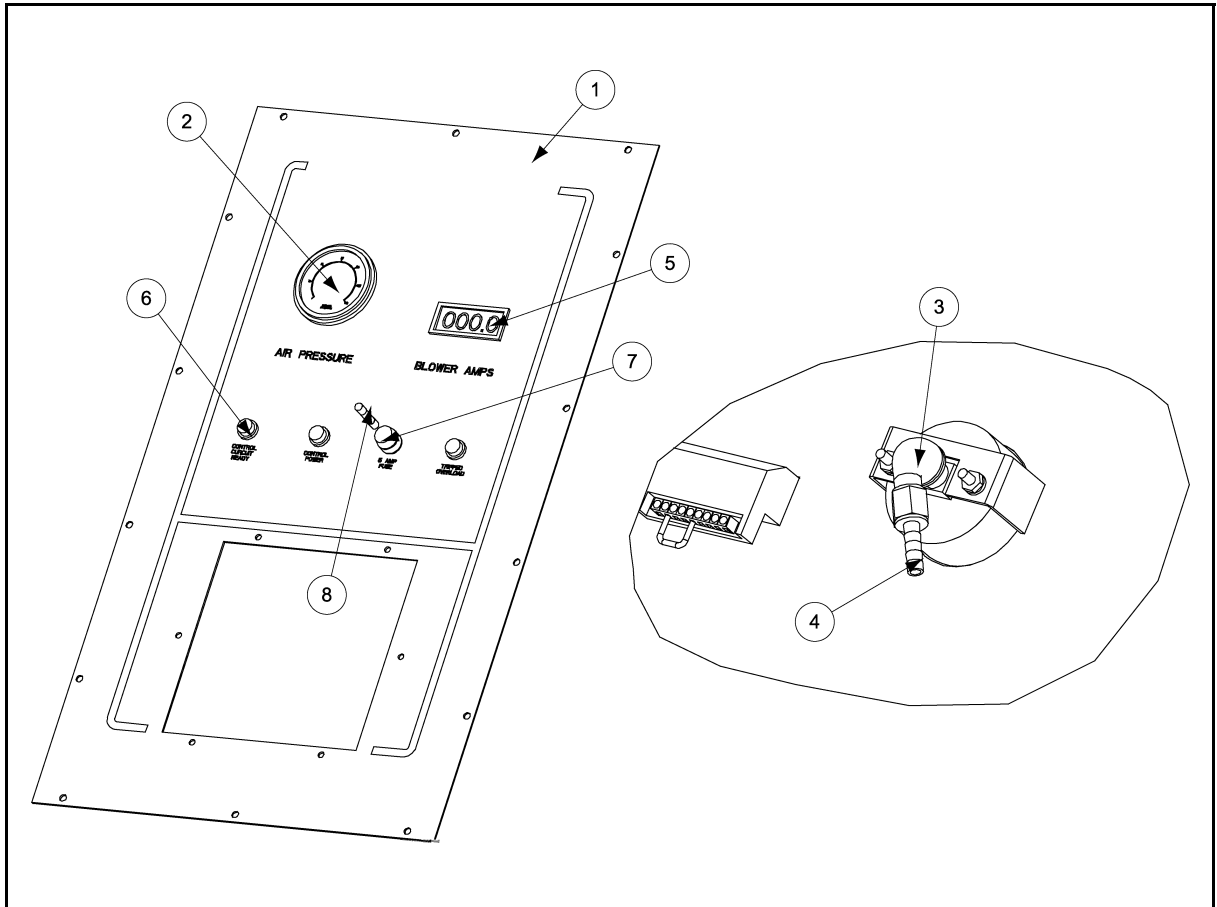

Panel Module Assembly - Digital

Ref #	Part #	Qty	Description
1	8015075D	1AR	Panel-W/Silkscreen Digi amp DMC
1	8015121D	1AR	Panel-W/Silkscreen Digi amp FFI
2	PT1125	1	Gauge- (Pressure) 2-1/2" 15 PSI
3	4FH0452	1	Fit-elbow,street(90) 1/4 NPT
4	4FH1122	1	Fit-hose Barb,1/4 x 1/4 Brass
5	AS-0211A	1	Digital Amp Meter Asy W/Jumper
6	TFH-2021	3	Light Red Neon No Leads 125 VAC
7	1EL0826	1	Fuseholder-Panmnt(CSA)30A 250 V
8	1EL0754	1	Fuse- AGC5 250 V 5 Amp

Panel Module Assembly - Analog

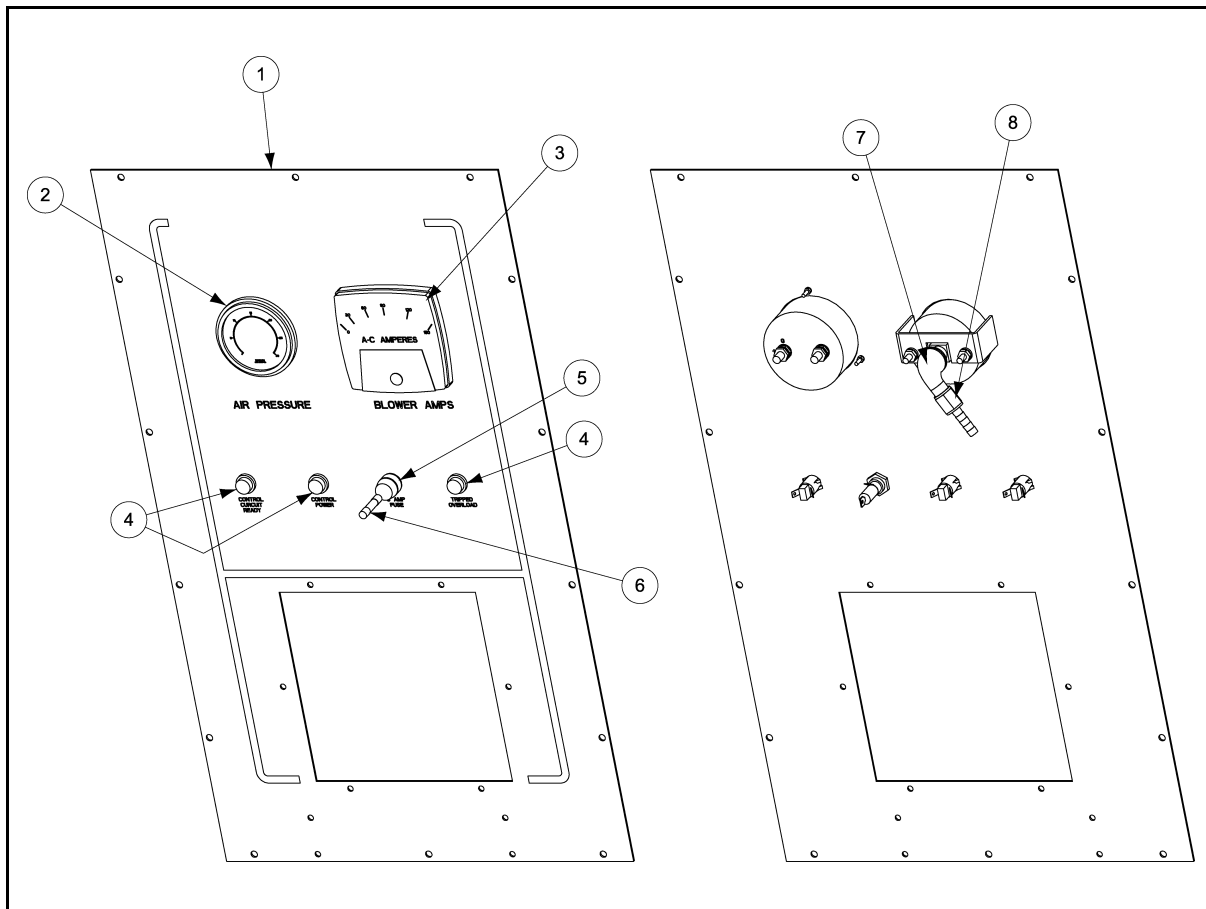

Panel Module Assembly - Analog

Ref #	Part #	Qty	Description
1	8015075	1	Single Main Panel Deadfront-DMC
1	8015121	1	Single Main Panel Deadfront-FFI
2	PT1125	1	Gauge- (Pressure) 2-1/2" 15 PSI
3	2EL0290	1	Amp Meter Panel 0-150 Amp
4	TFH-2021	3	Light Red Neon Spade Term 125 VAC
5	1EL0826	1	Fuseholder-Panel Mount 30a 250 V
6	1EL0719	1	Fuse- AGC-2 250 V 2 Amp
7	4FH0452	1	Fitting-elbow-street(90) 1/4 NPT
8	4FH1122	1	Fitting-hose Barb 1/4 x 1/4 Brass

12. PARTS LIST

Switch Panel Assembly - Standard

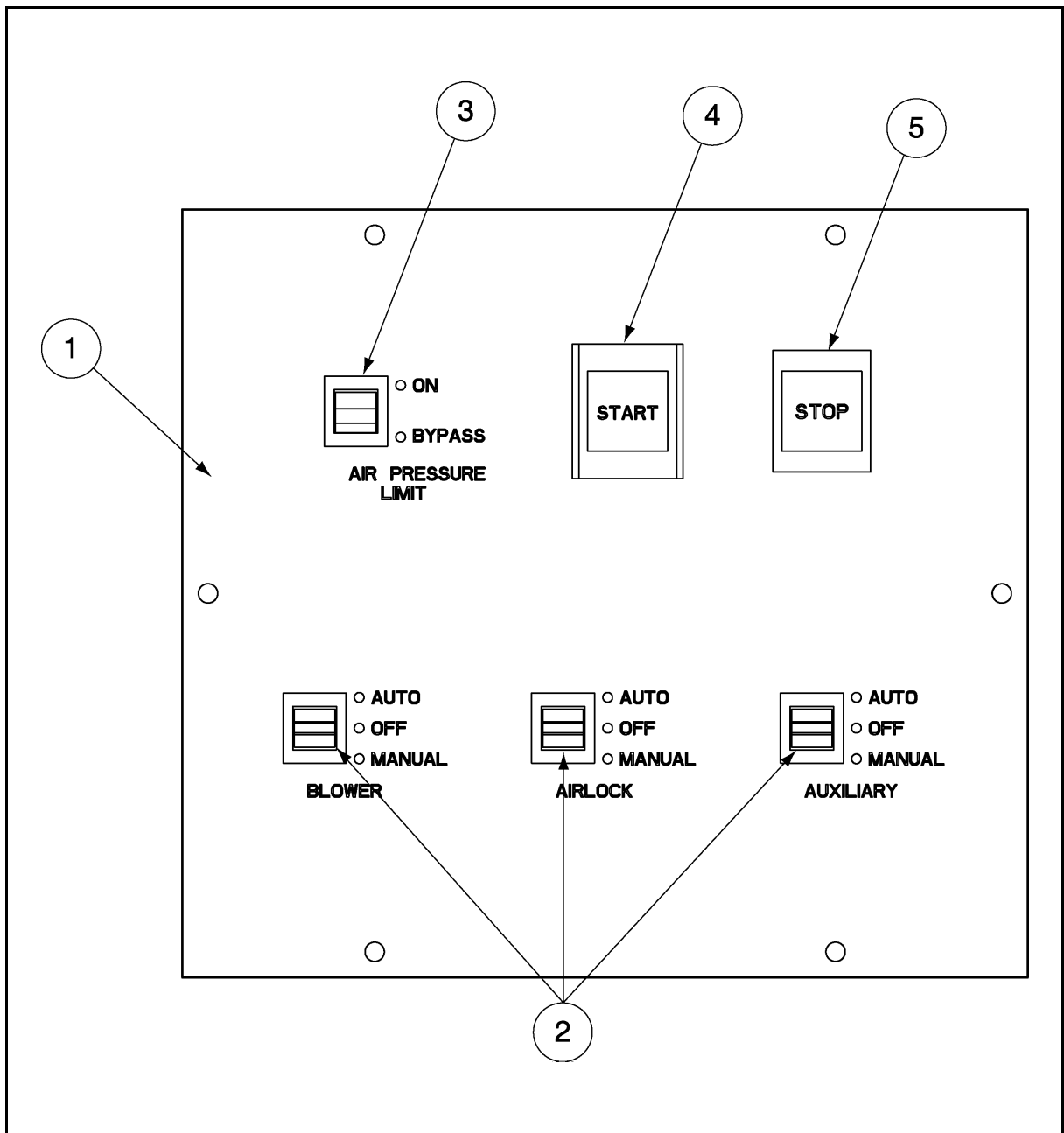

Switch Panel Assembly - Standard

Ref #	Part #	Qty	Description
1	8015078	1	Switch Panel-Standard
2	2EL0668	3	Lever Switch-SPDT (ON-OFF-ON)
3	2EL0659	1	Lever Switch-SPDT (ON-NONE-ON)
4	2EL0618	1	Pushbutton Switch-SPST (START)
5	2EL0619	1	Pushbutton Switch-SPST (STOP)

Switch Panel Assembly - Twin

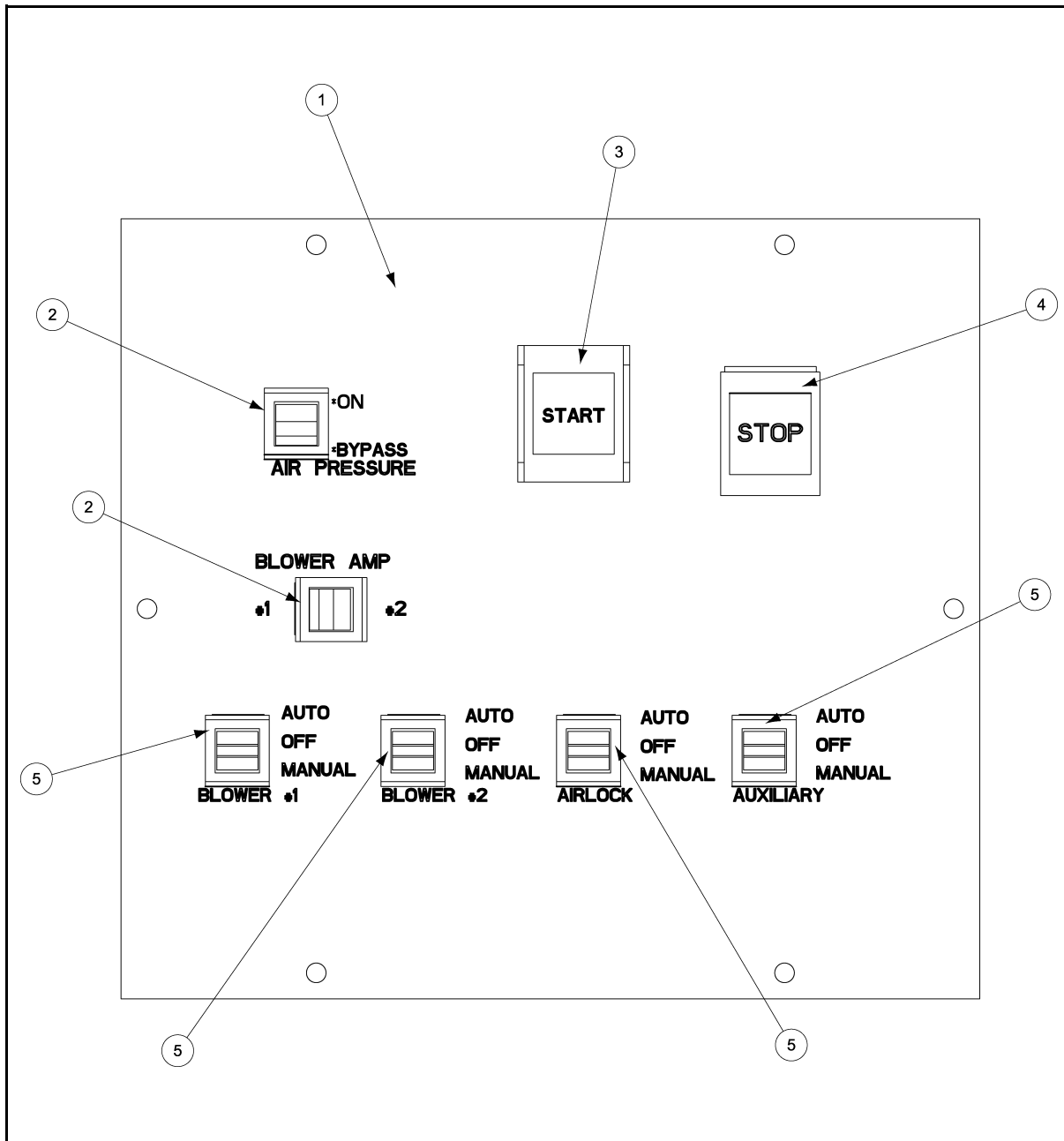

Switch Panel Assembly - Twin

Ref #	Part #	Qty	Description
1	8015110	1	Switch Panel-Twin
2	2EL0659	2	Lever Switch-Spdt (ON-NONE-ON)
3	2EL0618	1	Pushbutton Switch-SPST (START)
4	2EL0619	1	Pushbutton Switch-SPST (STOP)
5	2EL0668	4	Lever Switch-SPDT (ON-OFF-ON)

12. PARTS LIST

Standard Control Panel Assembly - 230 V 10-30 HP

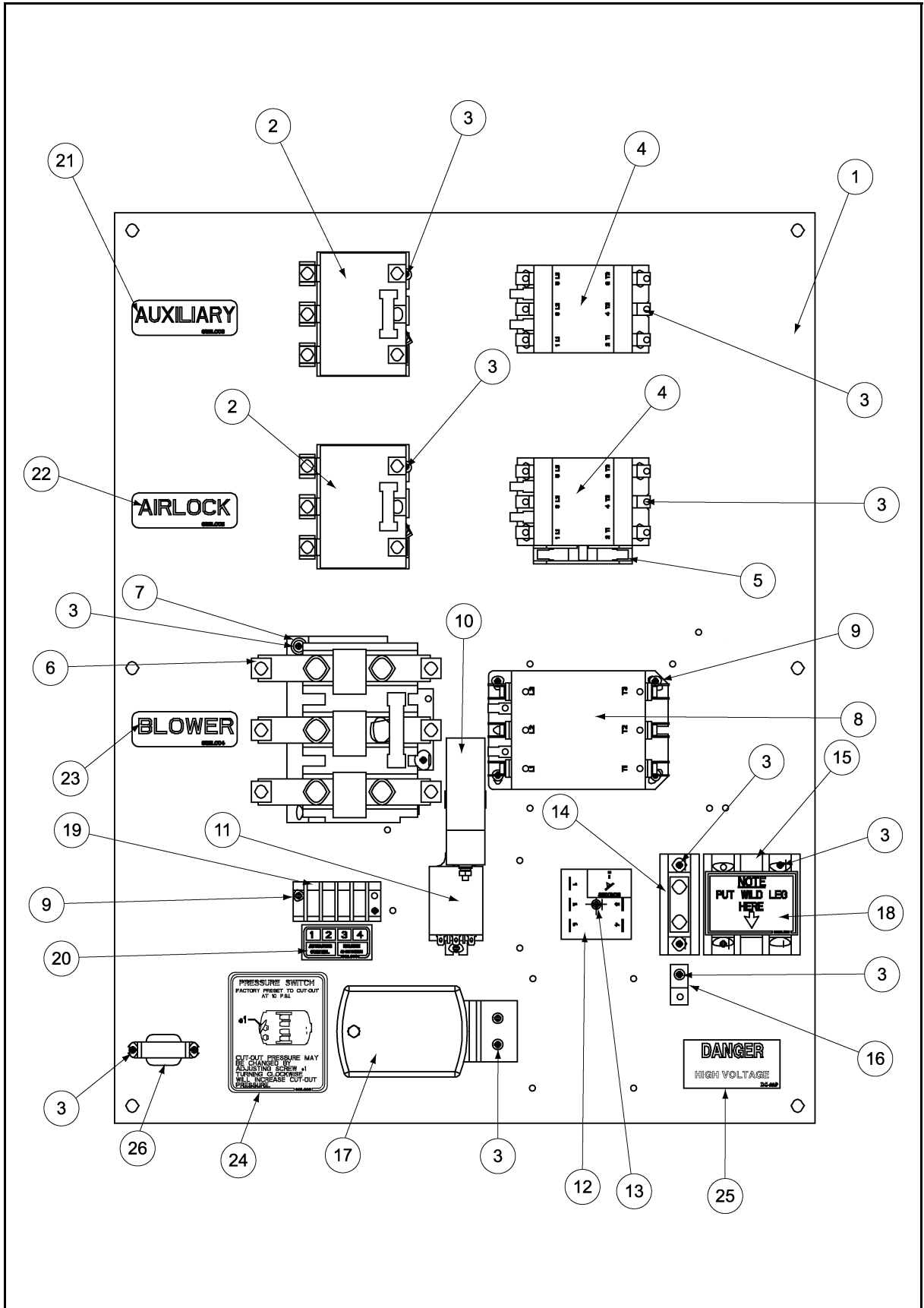

12. PARTS LIST

Standard Control Panel Assembly - 230 V 10-30 HP

Ref #	Part #	Analog Qty	Digital Qty	Description
1	8015079	1	1	Air Sys-control Panel (SNGL)
2	2EL0281	2	2	Relay THRML Overload 26 Amp
3	S-1158	19	21	Screw TCSF #8-32 x 1/2 PHP Zn
4	2EL0243	2	2	40A Contactor-Magnetic (CSA)
5	2EL0648	1	1	Contact- Auxiliary Motor Contactor
6	2EL0282	1	1	Relay-THRML Overload (CSA) 86 Amp
7	S-3674	2	2	Washer Flat #10 SAE Zn
8	2EL0248	1	1	Contactor- Magnetic (CSA) 90 Amp
9	S-6557	6	6	Screw TCSF #8-32 x 3/4 PHP Zn
10	2EL0307	1	-	Transformer-current 150:5 Ratio
	2EL0368	-	1	Transformer-current 200:5 Ratio
11	2EL0273	1	1	Relay-3 PDT 5A 120 V Deltro
12	801E047	1	1	Timer-Off Delay, 15 Sec Asy
13	S-7124	1	1	Screw Tcsf #8-32 x 1 PHP Zn
14	1EL0909	1	1	Pwr Dist. Blk 175A 600 V 1P
15	C-8018	1	1	Terminal Block 185A 3 Pole 1:4
16	E160-1137	1	1	Lug Ground-#TA-2 (CSA)
17	801E018	1	1	High Pressure Switch Asy
18	602L013	1	1	Decal-wild Leg
19	1773	1	1	Terminal Block 4 Pole 2 Row
20	801L006	1	1	Decal-Terminal Strip
21	802L006	1	1	Decal-Auxiliary
22	802L005	1	1	Decal-Airlock
23	802L004	1	1	Decal-Blower
24	801L003	1	1	Decal-Pressure Switch
25	DC-889	1	1	Decal-Danger High Voltage All PF
26	AS-0211T	-	1	5 Amp Limit Transformer-Digital Amp

12. PARTS LIST

Standard Control Panel Assembly - 230 V 10-30 HP Used In 8015071 Control Box (CSA Listed)

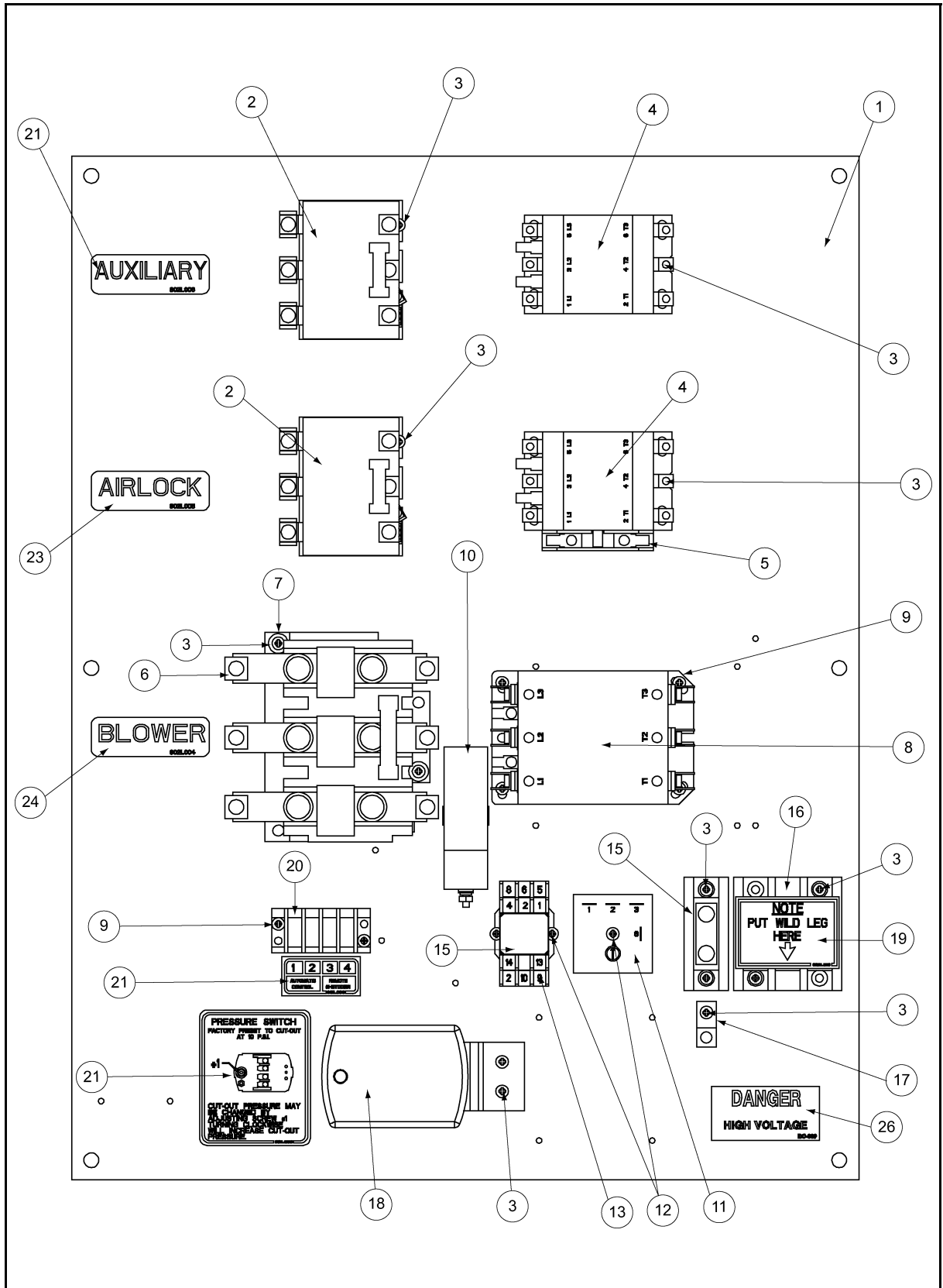

12. PARTS LIST

Standard Control Panel Assembly - 230 V 10-30 HP Used in 8015071 Control Box (CSA Listed)

Ref #	Part #	New CSA Design	Description
1	8015079	1	Air Sys-control Panel (SNGL)
2	2EL0281	2	Relay THRML Oveload 26 Amp
3	S-1158	17	Screw TCSF #8-32 x 1/2 PHP Zn
4	2EL0243	2	40A Contactor-Magnetic (CSA)
5	2EL0648	1	Contact- Auxiliary Motor Contactor
6	2EL0282	1	Relay-THRML OVERLD (CSA) 86 Amp
7	S-3674	2	Washer Flat #10 SAE Zn
8	2EL0248	1	Contactor-Magnetic (CSA) 90 Amp
9	S-6557	6	Screw TCSF #8-32 x 3/4 PHP Zn
10	2EL0307	1	Transformer-Current 150:5 Ratio
11	801E047	1	Timer-off Delay, 15 Sec Asy
12	S-7124	3	Screw Tcsf #8-32 x 1 PHP Zn
13	7097555	1	Relay Base,3 PDT, Small Square
14	HF-7203	1	Relay 3 PDT 120 V RH3B-U IDEC
15	1EL0909	1	Pwr Dist. Blk 175A 600 V 1P
16	C-8018	1	Terminal Block 185A 3 Pole 1:4
17	E160-1137	1	Lug Ground-#TA-2 (CSA)
18	801E018	1	High Pressure Switch Asy
19	602L013	1	Decal-Wild Leg
20	1773	1	Terminal Block 4 Pole 2 Row
21	801L006	1	Decal-Terminal Strip
22	802L006	1	Decal-Auxiliary
23	802L005	1	Decal-Airlock
24	802L004	1	Decal-Blower
25	801L003	1	Decal-Pressure Switch
26	DC-889	1	Decal-Danger High Voltage All PF

12. PARTS LIST

Standard Control Panel Assembly - 230 V 40 HP

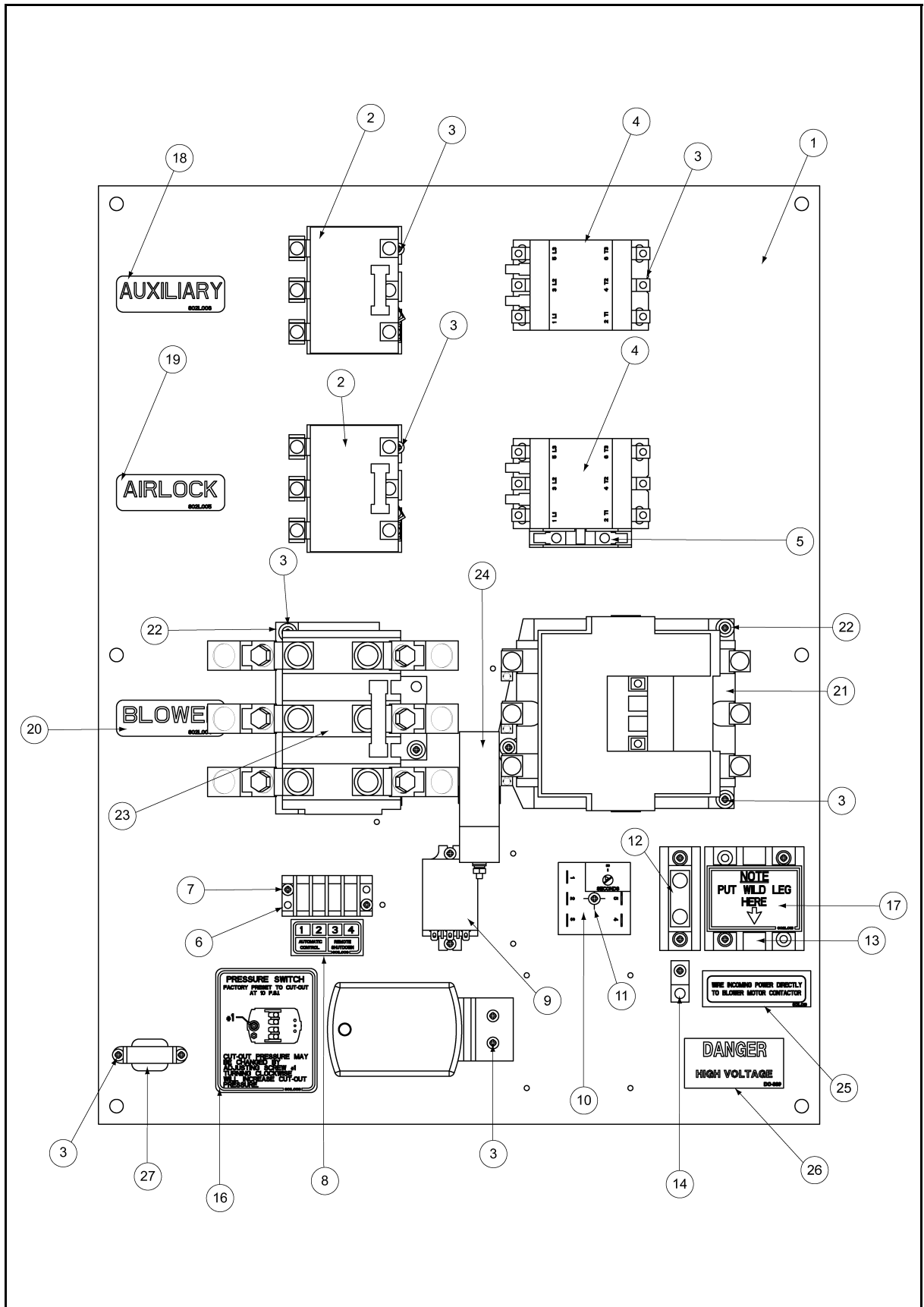

12. PARTS LIST

Standard Control Panel Assembly - 230 V 40 HP

Ref #	Part #	Analog Qty	Digital Qty	Description
1	8015079	1	1	Air Sys-Control Panel (SNGL)
2	2EL0281	2	2	Relay THRML Oveload 26 Amp
3	S-1158	22	24	Screw TCSF #8-32 x 1/2 PHP Zn
4	2EL0243	2	2	40A Contactor-Magnetic (CSA)
5	2EL0648	1	1	Contact-Auxiliary Motor Contactor
6	1773	1	1	Terminal Block 4 Pole 2 Row
7	S-6557	2	2	Screw TCSF #8-32 x 3/4 PHP Zn
8	801L006	1	1	Decal-Terminal Strip
9	2EL0273	1	1	Relay-3PDT 5A 120 V Deltro
10	801E047	1	1	Timer-Off Delay, 15 SEC Asy
11	S-7124	1	1	Screw TCSF #8-32 x 1 PHP Zn
12	1EL0909	1	1	Pwr Dist. Blk 175A 600 V 1P
13	C-8018	1	1	Terminal Block 185A 3 Pole 1:4
14	E160-1137	1	1	Lug Ground-#TA-2 (CSA)
15	801E018	1	1	High Pressure Switch Asy
16	801L003	1	1	Decal-Pressure Switch
17	602L013	1	1	Decal-Wild Leg
18	802L006	1	1	Decal-Auxiliary
19	802L005	1	1	Decal-Airlock
20	802L004	1	1	Decal-Blower
21	2EL0249	1	1	Contacto-120 Amp 120 V Coil
22	S-3674	5	5	Washer Flat #10 SAE Zn
23	2EL0271	1	1	Relay-Overload Size 4 133 Amp
24	2EL0307	1	-	Transformer-Current 150:5 Ratio
	2EL0368	-	1	Transformer-Current 200:5 Ratio
25	801L019	1	1	Decal-Wire Incoming PWR
26	DC-889	1	1	Decal-Danger High Voltage All PF
27	AS-0211T	-	1	5 Amp Limit Transformer-Digital Amp

12. PARTS LIST

Twin Control Panel Assembly - 230 V 7-15 HP

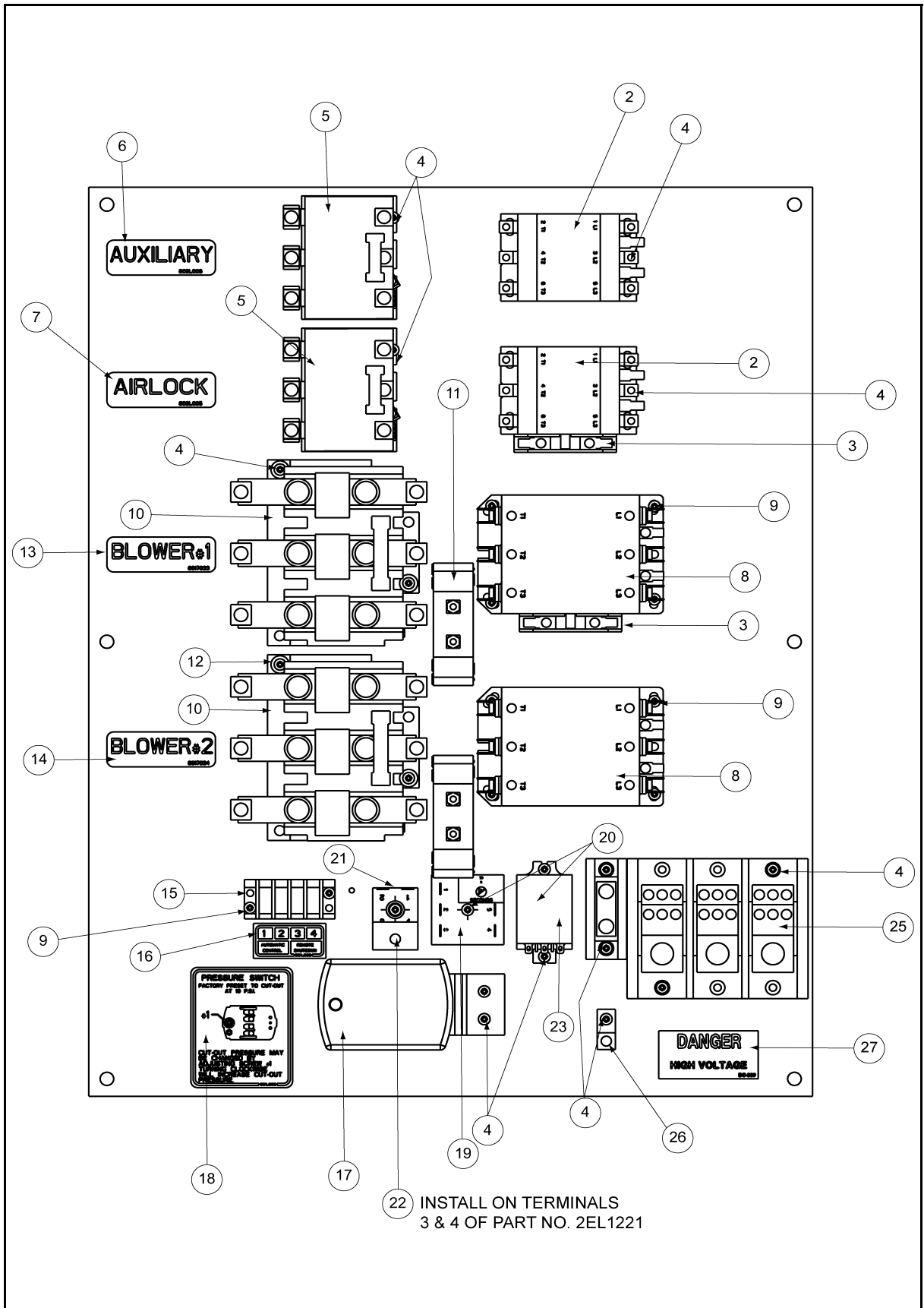

12. PARTS LIST

Twin Control Panel Assembly - 230 V 7-15 HP

Ref #	Part #	Analog Qty	Digital Qty	Description
1	8015111	1	1	Air Sys-Control Panel (Twin)
2	2EL0243	2	2	40a Contactor-Magnetic (CSA)
3	2EL0648	2	2	Contact-Auxiliary Motor Contactor
4	S-1158	21	23	Screw TCSF #8-32 x 1/2 PHP Zn
5	2EL0281	2	2	Relay THRML Oveload 26 Amp
6	802L006	1	1	Decal-Auxiliary
7	802L005	1	1	Decal-Airlock
8	2EL0248	2	2	Contactor-Magnetic (CSA) 90 Amp
9	S-6557	10	10	Screw TCSF #8-32 x 3/4 PHP Zn
10	2EL0282	2	2	Relay-THRML OVERLD (CSA) 86 Amp
11	2EL0307	2	-	Transformer-Current 150:5 Ratio
11	2EL0368	-	2	Transformer-Current 200:5 Ratio
12	S-3674	4	4	Washer Flat #10 Sae Zn
13	8017033	1	1	Decal-Blower #1
14	8017034	1	1	Decal-Blower #2
15	1773	1	1	Terminal Block 4 Pole 2 Row
16	801L006	1	1	Decal-Terminal Strip
17	801E018	1	1	High Pressure Switch Asy
18	801L003	1	1	Decal- Pressure Switch
19	801E047	1	1	Timer-Off Delay, 15 Sec Asy
20	S-7124	2	2	Screw Tcsf #8-32x1 PHP Zn
21	2EL1221	1	1	Timer -.5 To 60 Seconds
22	2EL1223	1	1	Timer-Module, .5-20 Sec
23	2EL0273	1	1	Relay-3PDT 5A 120 V Deltro
24	1EL0909	1	1	Pwr Dist. Blk 175A 600 V 1P
25	1EL0912	1	1	Power Dist. Blk 3P 600 VAC
26	E160-1137	1	1	Lug Ground-#TA-2 (CSA)
27	DC-889	1	1	Decal-Danger High Voltage All PF
28	AS-0211T	-	1	5 Amp Limit Transformer-Digital Amp

12. PARTS LIST

Twin Control Panel Assembly - 230 V 7-15 HP Used in 8015114 Control Box (CSA Listed)

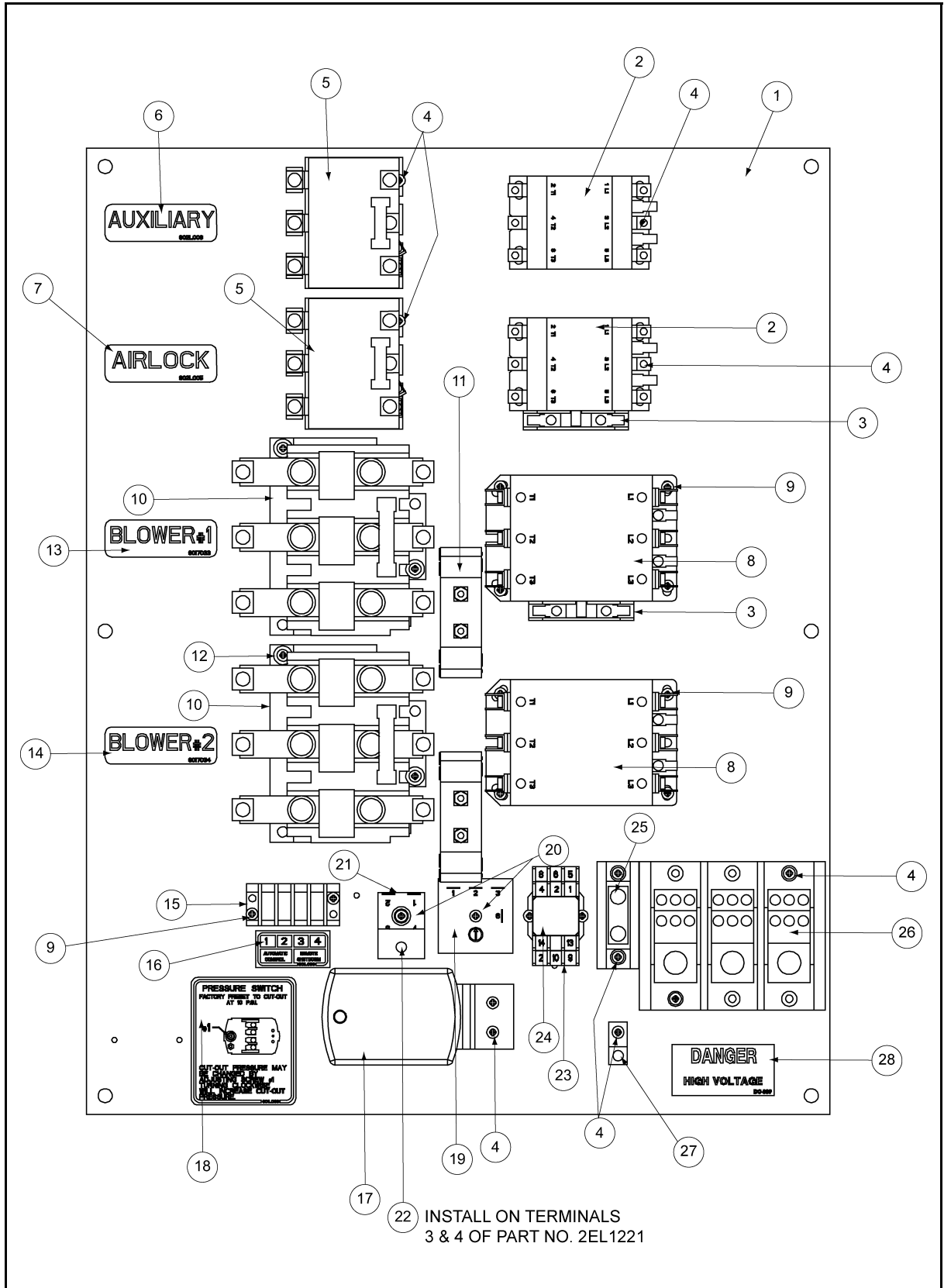

12. PARTS LIST

Twin Control Panel Assembly - 230 V 7-15 HP Used in 8015114 Control Box (CSA Listed)

Ref #	Part #	New CSA Design Qty	Description
1	8015111	1	Air Sys-Control Panel (Twin)
2	2EL0243	2	40A Contactor-Magnetic (CSA)
3	2EL0648	2	Contact-Auxiliary Motor Contactor
4	S-1158	19	Screw TCSF #8-32 x 1/2 PHP Zn
5	2EL0281	2	Relay THRML Oveload 26 Amp
6	802L006	1	Decal-Auxiliary
7	802L005	1	Decal-Airlock
8	2EL0248	2	Contactor-Magnetic (CSA) 90 Amp
9	S-6557	10	Screw TCSF #8-32 x 3/4 PHP Zn
10	2EL0282	2	Relay-THRML Overload (CSA) 86 Amp
11	2EL0307	2	Transformer-Current 150:5 Ratio
12	S-3674	4	Washer Flat #10 SAE Zn
13	8017033	1	Decal-Blower #1
14	8017034	1	Decal-Blower #2
15	1773	1	Terminal Block 4 Pole 2 Row
16	801L006	1	Decal-Terminal Strip
17	801E018	1	High Pressure Switch Asy
18	801L003	1	Decal-Pressure Switch
19	801E047	1	Timer-Off Delay, 15 Sec Asy
20	S-7124	4	Screw TCSF #8-32 x 1 PHP Zn
21	2EL1221	1	Timer-.5 To 60 Seconds
22	2EL1223	1	Timer-Module, .5-20 Sec
23	7097555	1	Relay Base, 3 PDT, Small Square
24	HF-7203	1	Relay 3PDT 120 V RH38-U IDEC
25	1EL0909	1	PWR Dist. Blk 175A 600 V 1P
26	1EL0912	1	Power Dist. Blk 3P 600 VAC
27	E160-1137	1	Lug Ground-#TA-2 (CSA)
28	DC-889	1	Decal-Danger High Voltage All PF

12. PARTS LIST

Standard Control Panel Assembly - 460 V 10 - 40 HP

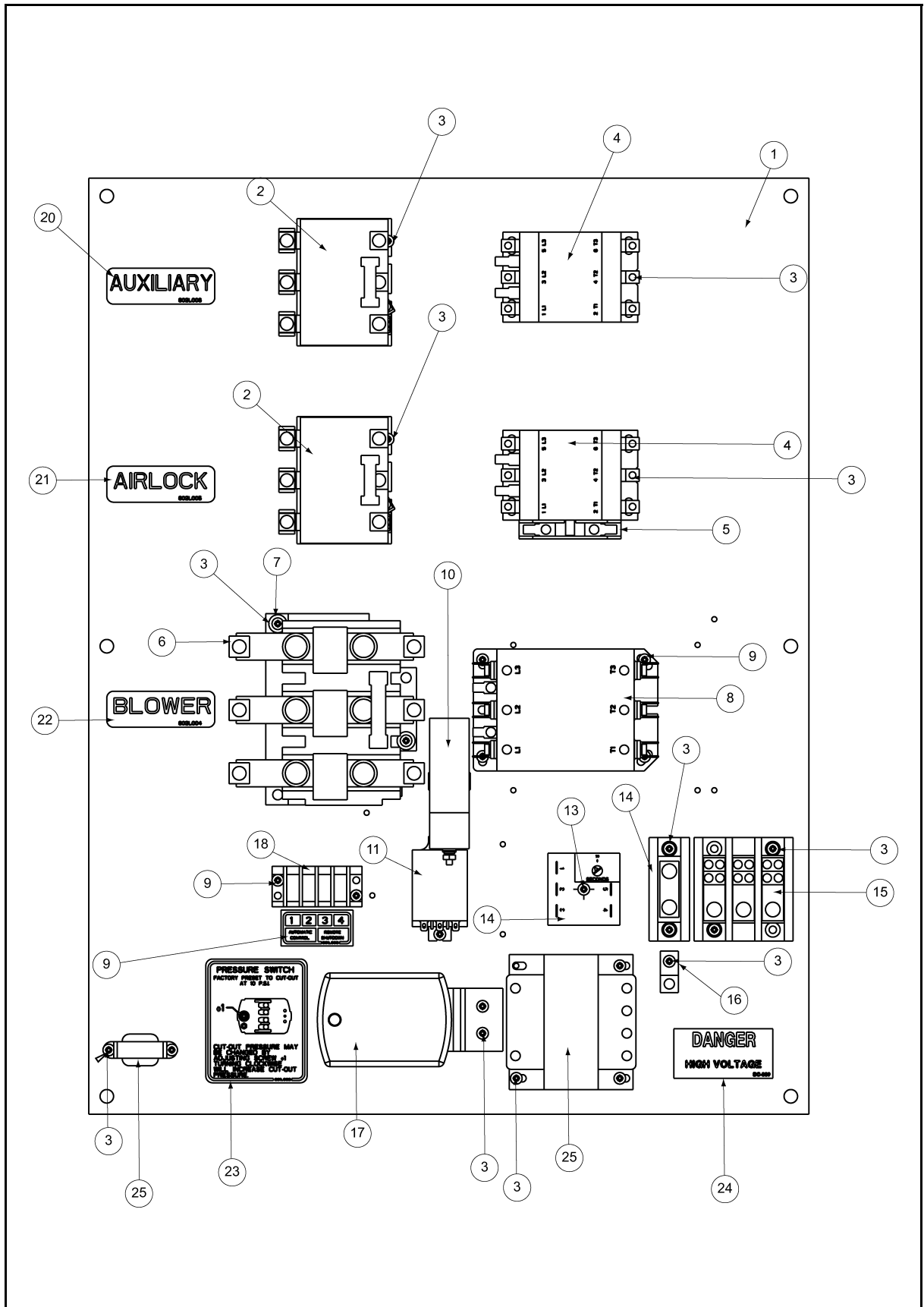

12. PARTS LIST

Standard Control Panel Assembly - 230 V 10-40 HP

Ref #	Part #	Analog Qty	Digital Qty	Description
1	8015079	1	1	Air Sys-Control Panel (SNGL)
2	2EL0281	2	2	Relay Thermal Oveload 26 Amp
3	S-1158	23	25	Screw TCSF #8-32 x 1/2 PHP Zn
4	2EL0243	2	2	40A Contactor-Magnetic (CSA)
5	2EL0648	1	1	Contact-Auxiliary Motor Contactor
6	2EL0282	1	1	Relay-THRML OVERLD (CSA) 86 Amp
7	S-3674	2	2	Washer Flat #10 SAE Zn
8	2EL0248	1	1	Contactor-Magnetic (CSA) 90 Amp
9	S-6557	6	6	Screw TCSF #8-32 x 3/4 PHP Zn
10	2EL0307	1	-	Transformer-Current 150:5 Ratio
	2EL0307	-	1	Transformer-Current 200:5 Ratio
11	2EL0273	1	1	Relay-3 PDT 5A 120 V Deltro
12	801E047	1	1	Timer-Off Delay, 15 Sec Asy
13	S-7124	1	1	Screw TCSF #8-32 x 1 PHP Zn
14	1EL0909	1	1	Pwr Dist. Blk 175A 600 V 1P
15	C-8018	1	1	Terminal Block 185A 3 Pole 1:4
16	E160-1137	1	1	Lug Ground-#TA-2 (CSA)
17	801E018	1	1	High Pressure Switch Asy
18	1773	1	1	Terminal Block 4 Pole 2 Row
19	801L006	1	1	Decal-Terminal Strip
20	802L006	1	1	Decal-Auxiliary
21	802L005	1	1	Decal-Airlock
22	802L004	1	1	Decal-Blower
23	801L003	1	1	Decal-Pressure Switch
24	DC-889	1	1	Decal-Danger High Voltage All PF
25	2EL0308	1	1	Transformer-460 V-120 V .15 KVA
26	AS-0211T	-	1	5 Amp Limit Transformer-Digital Amp

12. PARTS LIST

Control Panel Assembly - 460 V 10-40 HP Used In 8015072 Control Box (CSA Listed)

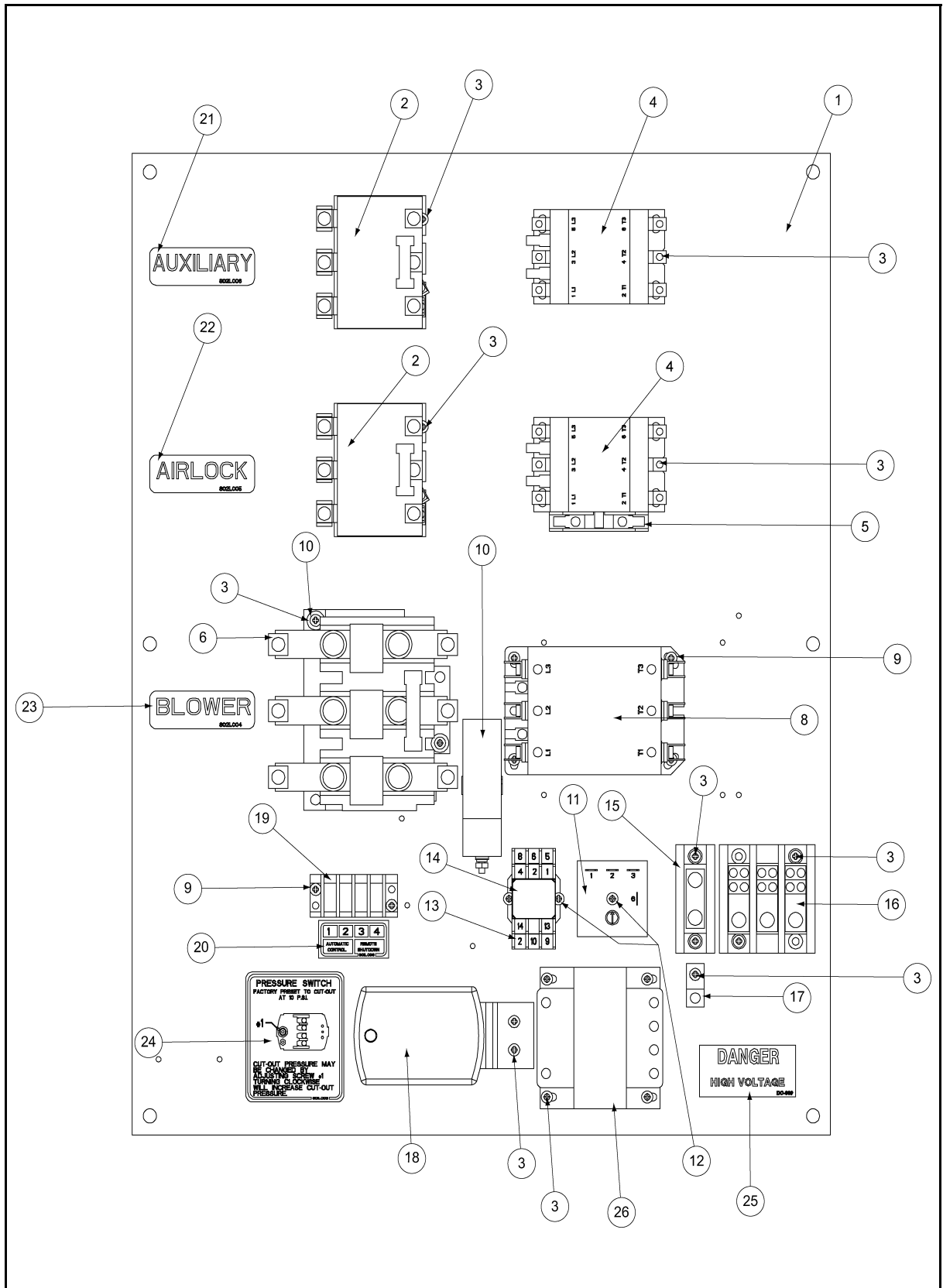

12. PARTS LIST

Control Panel Assembly - 460 V 10 - 40 HP Used In 8015072 Control Box (CSA Listed)

Ref #	Part #	New CSA Design Qty	Description
1	8015079	1	Air Sys-Control Panel (SNGL)
2	2EL0281	2	Relay THRML Oveload 26 Amp
3	S-1158	21	Screw TCSF #8-32 x 1/2 PHP Zn
4	2EL0243	2	40A Contactor-magnetic(Csa)
5	2EL0648	1	Contact-Auxiliary Motor Contactor
6	2EL0282	1	Relay-THRML OVERLD (CSA) 86 Amp
7	S-3674	2	Washer Flat #10 SAE Zn
8	2EL0248	1	Contactor-magnetic (CSA) 90 Amp
9	S-6557	6	Screw TCSF #8-32 x 3/4 PHP Zn
10	2EL0307	1	Transformer-Current 150:5ratio
11	801E047	1	Timer-Off Delay, 15 Sec Asy
12	S-7124	3	Screw TCSF #8-32 x 1 PHP Zn
13	7097555	1	Relay Base, 3 PDT, Small Square
14	HF-7203	1	Relay 3 PDT 120 V RH3B-U IDEC
15	1EL0909	1	PWR Dist. Blk 175A 600v 1p
16	C-8018	1	Terminal Block 185A 3 Pole 1:4
17	E160-1137	1	Lug Ground-#Ta-2 (CSA)
18	801E018	1	High Pressure Switch Asy
19	1773	1	Terminal Block 4 Pole 2 Row
20	801L006	1	Decal-Terminal Strip
21	802L006	1	Decal-Auxiliary
22	802L005	1	Decal-Airlock
23	802L004	1	Decal-Blower
24	801L003	1	Decal-Pressure Switch
25	DC-889	1	Decal-Danger High Voltage All PF
26	2EL0308	1	Transformer-460 V-120 V .15 KVA

13. TROUBLESHOOTING

Problem	Solution
1. System Plugs Up	<ol style="list-style-type: none"> 1. Check belt tension on air blower and tighten if loose. 2. Check air filter and clean out. Locate in a place where there is less dust. 3. Check tubing system for any obstructions. 4. Reduce feed-in rate. 5. Air pressure switch setting may be too low. 6. Outlet gate valve too far open.
2. Excessive Grain Damage	<ol style="list-style-type: none"> 1. May be overfeeding airlock, causing vanes to shear off grain. Reduce feed rate. 2. Air velocity may be excessive. Slow air blower by changing pulleys or by opening gate valve. 3. Damage can occur if system is running at less than full capacity. Increase feed rate. 4. Rubber hose used to change grain direction, or used for extended lengths. 5. Airlock shear protector installed wrong.
3. Airlock Stops or is Noisy	<ol style="list-style-type: none"> 1. A foreign object may have become lodged in the airlock vanes. 2. Check belt tension. 3. Check gearbox drive. 4. The rotor vanes may be rubbing on the ends of the airlock. Check clearance at both ends of rotor and center in housing by loosening the set screws in the bearings on both ends of the rotor shaft and moving rotor. Tighten set screws after repositioning. 5. The rotor vanes may have become rusted to the airlock housing. The airlock can be broken loose by using a pipe wrench on the exposed rotor shaft. <p style="text-align: center;">⚠ CAUTION ⚠</p> <p>The worm drive gearbox <u>cannot</u> be driven in reverse and can be damaged. Remove the airlock drive chain before attempting to turn the airlock by hand.</p> <hr/> <ol style="list-style-type: none"> 6. "U" cup packings on rotor too tight. (Contact factory)

13. TROUBLESHOOTING

Problem	Solution
4. Unit will not start, "ready light" is not on.	<ol style="list-style-type: none">1. Check AC power supply.2. Check control box fuses.3. Thermal overload tripped (overload indicator is on).4. Air pressure limit switch may be misadjusted (less than 5 PSI). If pressure switch is not reset, turn pressure adjustment clockwise until switch resets.5. Be sure "start" switch is pushed.
5. Unit will not start, the "ready light" is on.	<ol style="list-style-type: none">1. Blower, airlock and auxiliary switches must be in either "Auto" or "Manual" to operate.2. The automatic control not wired correctly or not working. (Requires a closed contact across TB1 and TB2 to auto start).
6. Blower Motor Trips Thermal Overload	<ol style="list-style-type: none">1. Check current draw using Amp meter. The motor should not be pulling more current than the name plate specifies. Reduce feed rate if excessive.2. Check heater sizes.3. Check for loose connections and/or too small gauge wire.4. Wrong voltage (either high or low).5. Too much load due to obstructions, bad bearings or dry gears.
7. No Control Voltage	<ol style="list-style-type: none">1. Control Fuse inside the control box is down.2. Check main power for proper voltage.

14. COUPLINGS

How to Handle Handling Couplings

1. Couplings are shipped ready-to-install... do not disassemble. To prevent gasket from slipping out of proper position, always grasp coupling as shown in [Figure 14A](#). This will save time by maintaining proper position of gasket and sleeve in relation to shell and flange.

Installing Couplings

1. Confirm pipe O.D. size you intend joining. Each compression coupling has been factory inspected for proper O.D. size before shipment.
2. Be sure outside surface of pipe is dry, and free of dirt, grease or external burrs. (Burrs & jagged pipe ends can cut gasket; dirt & grease can cause coupling slippage.)
3. Grasp coupling as shown in [Figure 14A](#) to keep gasket and sleeve (and gasket protector when used) in separate quadrants, as shown in [Figure 14A](#). Be sure gasket teeth mesh and do not overlap.
4. Slide coupling over one pipe past end, then butt pipe ends (a small gap 1/16 maximum at butt joint will not reduce coupling performance). Slide coupling back until coupling and gasket protector are centered over joint. Use care when sliding coupling into place...avoid wrinkling of gasket or gasket protector.
5. The gasket protector provides a bleed path for static electricity.
6. Partially tighten bolts evenly as follows:

1/2 bolt size - 45 ft. lbs. torque

5/8 bolt size - 65 ft. lbs. torque

3/4 bolt size - 95 ft. lbs. torque

(Where SAE GR 5 5/8 bolts are specified tighten to 95 ft. lbs. For couplings with aluminum shell and inner sleeve do not exceed 40 ft. lbs.)

7. When properly and evenly tightened to the recommended torque the coupling installation is complete. The top edges of the flanges will touch and flanges appear as a vee when viewed from the end, as shown in [Figure 14A](#). **DO NOT** attempt tightening bolts to flatten flange faces together, as this exceeds recommended limits.

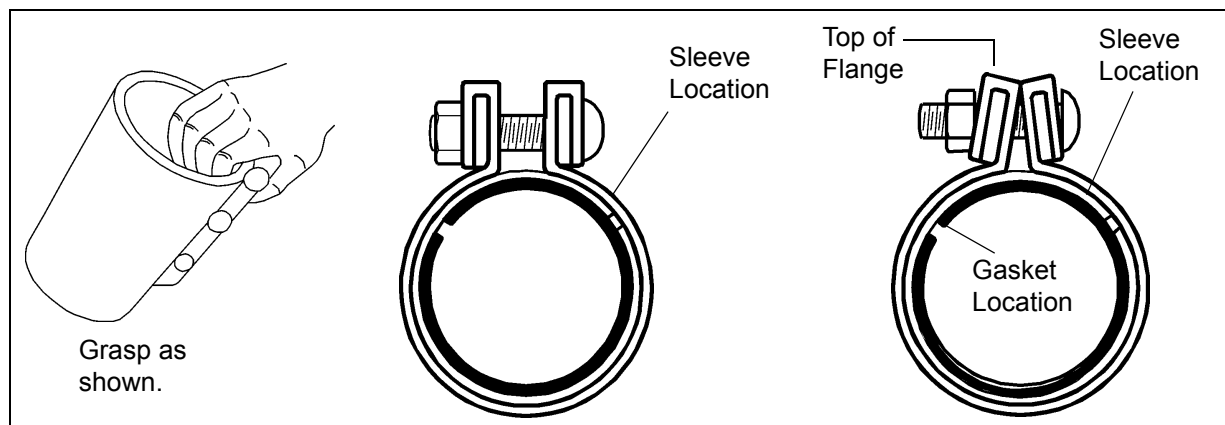

Figure 14A

WARRANTY

THE GSI GROUP, INC. (GSI) WARRANTS ALL PRODUCTS WHICH IT MANUFACTURES TO BE FREE OF DEFECTS IN MATERIAL AND WORKMANSHIP UNDER NORMAL USAGE AND CONDITIONS FOR A PERIOD OF 12 MONTHS AFTER RETAIL SALE TO THE ORIGINAL END USER. THE PURCHASER'S SOLE REMEDY AND GSI'S ONLY OBLIGATION SHALL BE TO REPAIR OR REPLACE, AT GSI'S OPTION AND EXPENSE, PRODUCTS THAT, IN GSI'S SOLE JUDGMENT, CONTAIN A MATERIAL DEFECT DUE TO MATERIALS OR WORKMANSHIP. ALL DELIVERY AND SHIPMENT CHARGES TO AND FROM GSI'S FACTORY WILL BE PURCHASER'S RESPONSIBILITY. EXPENSES INCURRED BY OR ON BEHALF OF THE PURCHASER WITHOUT PRIOR WRITTEN AUTHORIZATION FROM AN AUTHORIZED EMPLOYEE OF GSI SHALL BE THE SOLE RESPONSIBILITY OF THE PURCHASER.

EXCEPT FOR THE LIMITED WARRANTY EXPRESSED ABOVE, GSI MAKES NO FURTHER WARRANTY OF ANY KIND, EXPRESS OR IMPLIED, INCLUDING, WITHOUT LIMITATION, WARRANTIES OF MERCHANTABILITY OR FITNESS FOR A PARTICULAR PURPOSE OR USE IN CONNECTION WITH (i) PRODUCT MANUFACTURED OR SOLD BY GSI OR (ii) ANY ADVICE, INSTRUCTION, RECOMMENDATION OR SUGGESTION PROVIDED BY AN AGENT, REPRESENTATIVE OR EMPLOYEE OF GSI REGARDING OR RELATED TO THE CONFIGURATION, INSTALLATION, LAYOUT, SUITABILITY FOR A PARTICULAR PURPOSE, OR DESIGN OF SUCH PRODUCTS.

GSI SHALL NOT BE LIABLE FOR ANY DIRECT, INDIRECT, INCIDENTAL OR CONSEQUENTIAL DAMAGES, INCLUDING, WITHOUT LIMITATION, LOSS OF ANTICIPATED PROFITS OR BENEFITS. PURCHASER'S SOLE AND EXCLUSIVE REMEDY IS AS SET FORTH IN THE LIMITED WARRANTY EXPRESSED ABOVE, WHICH SHALL NOT EXCEED THE AMOUNT PAID FOR THE PRODUCT PURCHASED. THIS WARRANTY IS NOT TRANSFERABLE AND APPLIES ONLY TO THE ORIGINAL PURCHASER. GSI SHALL HAVE NO OBLIGATION OR RESPONSIBILITY FOR ANY REPRESENTATIONS OR WARRANTIES MADE BY OR ON BEHALF OF ANY DEALER, AGENT OR DISTRIBUTOR OF GSI.

GSI ASSUMES NO RESPONSIBILITY FOR CLAIMS RESULTING FROM ERECTION DEFECTS OR UNAUTHORIZED MODIFICATIONS TO PRODUCTS WHICH IT MANUFACTURED. MODIFICATIONS TO PRODUCTS NOT SPECIFICALLY DELINEATED IN THE MANUAL ACCOMPANYING THE EQUIPMENT AT INITIAL SALE WILL NULLIFY THE PRODUCT WARRANTY THAT MIGHT HAVE BEEN OTHERWISE AVAILABLE.

THE FOREGOING WARRANTY SHALL NOT EXTEND TO PRODUCTS OR PARTS WHICH HAVE BEEN DAMAGED BY NEGLIGENT USE, MISUSE, ALTERATION OR ACCIDENT. THIS WARRANTY EXTENDS SOLELY TO ONLY PRODUCTS MANUFACTURED BY GSI. THIS WARRANTY IS EXCLUSIVE AND IN LIEU OF ALL OTHER WARRANTIES EXPRESS OR IMPLIED. GSI RESERVES THE RIGHT TO MAKE DESIGN OR SPECIFICATION CHANGES AT ANY TIME.

PRIOR TO INSTALLATION, PURCHASER HAS THE RESPONSIBILITY TO COMPLY WITH ALL FEDERAL, STATE AND LOCAL CODES WHICH MAY APPLY TO THE LOCATION AND INSTALLATION OF PRODUCTS MANUFACTURED OR SOLD BY GSI.

This equipment shall be installed in accordance with the current installation codes and applicable regulations which should be carefully followed in all cases. Authorities having jurisdiction should be consulted before installations are made.

G S I G R O U P



GSI Group, Inc.
1004 E. Illinois St.
Assumption, IL 62510-0020
Phone: 1-217-226-4421
Fax: 1-217-226-4420
Internet: <http://www.grainsystems.com>