

Air System Pneumatic Grain Conveying

6" - 2100 Bu/Hr

Owner's Manual

PNEG-1369

Date: 04-12-07

GSI GROUP



PNEG-1369

Contents

Chapter 1 Safety 4
 Safety Guidelines 4

Chapter 2 Decals 7
 Decal Placement 7

Chapter 3 Maintenance 11

Chapter 4 Air System 12
 Air System Capacities 12
 Capacity Chart 12
 Air System Installation Instructions 13
 Air System Capacities 14
 Air System Tubing Dimensions 15
 Elbow Angle Measurements 16
 Air System Set-Up Procedure 17
 6" Air System 2100 Motor Mounting Locations 20
 Air Systems Control Box Definitions 21

Chapter 5 Thermal Unit Chart 23
 Air System Control Box - Thermal Unit Chart 23

Chapter 6 Wiring Diagrams 24
 Overload Relay Settings for 2EL0284 ADJ. 24
 Thermal Overload Information 25
 Schematic With Digital Amp Meter 26
 Schematic with Analog Amp Meter - Using 2EL0273 Control Relay 27
 Schematic With Analog Amp Meter - Using HF-7203 Control Relay 28

Chapter 7 Control Box Operation 29
 Control Box Operational Procedures 29
 Air System Operation Guidelines 30

Chapter 8 Hook-Up Diagrams 32

Chapter 9 Parts 33
 6" (2100) with 1760RPM Motors Blower Parts 34
 Blower Filter Parts 38
 6" Airlock Parts 40
 Airlock Inlet Transition Assembly 42
 Inlet Tube Kit Parts 44
 Panel Module Assembly - Digital 45
 Panel Module Assembly - Analog 46
 Switch Panel Assembly - Standard 47
 Standard Control Panel - 230V 40-50 HP 48
 Control Panel Assembly - 230V 60-75 HP 50
 Blower Panel Assembly - 230V 60-75 HP 52
 Standard Control Panel - 460V 40-60 HP 54
 CSA Control Panel Assembly - 460V 40-60 HP 56
 Control Panel Assembly - 460V 75HP 58

Chapter 10 Couplings 60
 How to Handle Handling Couplings 60

Chapter 11 Trouble Shooting 61
 Electrical Trouble Shooting 62

Chapter 12 Warranty 63

1. SAFETY

Safety Guidelines

This manual contains information that is important for you, the owner/operator, to know and understand. This information relates to protecting **personal safety** and **preventing equipment problems**. It is the responsibility of the owner/operator to inform anyone operating or working in the area of this equipment of these safety guidelines. To help you recognize this information, we use the symbols that are defined below. Please read the manual and pay attention to these sections. Failure to read this manual and its safety instructions is a misuse of the equipment and may lead to serious injury or death.



This is the safety alert symbol. It is used to alert you to potential personal injury hazards. Obey all safety messages that follow this symbol to avoid possible injury or death.



DANGER indicates an imminently hazardous situation which, if not avoided, will result in death or serious injury.



WARNING indicates a potentially hazardous situation which, if not avoided, could result in death or serious injury.



CAUTION indicates a potentially hazardous situation which, if not avoided, may result in minor or moderate injury.



CAUTION used without the safety alert symbol indicates a potentially hazardous situation which, if not avoided, may result in property damage.



NOTE indicates information about the equipment that you should pay special attention to.

Follow Safety Instructions

Carefully read all safety messages in this manual and on your machine safety signs. Keep signs in good condition. Replace missing or damaged safety signs. Be sure new equipment components and repair parts include the current safety signs. Replacement safety signs are available from the manufacturer.

Learn how to operate the machine and how to use controls properly. Do not let anyone operate without instruction.

Keep your machinery in proper working condition. Unauthorized modifications to the machine may impair the function and/or safety and affect machine life.

If you do not understand any part of this manual and need assistance, contact your dealer.



Stay Clear of Moving Parts and Air Valves

Keep hands and feet away from moving parts. Be sure all people are clear of the equipment before start-up. Wear close fitting clothing.

Keep all shields and covers in place at all times.

Stay clear of air blast for valve. Always wear safety glasses to protect your eyes.

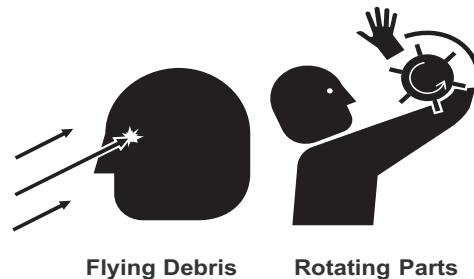

Install and Use equipment Properly

Ground all electrical equipment as well as the bin itself.

Disconnect all power before servicing or opening control box, adjusting, lubricating the equipment, or opening the control box inner panel.

All electrical hook-ups should be in accordance with local and National Electrical Code.

If three phase power is used, identify wild leg and wire according to electrical diagram.

Never use plastic tubing for any lines carrying grain.



1. SAFETY

Practice Safe Maintenance

Always lockout power source before servicing equipment.

Understand service procedures before doing work. Keep area clean and dry.

Never lubricate, service, or adjust machine while it is in operation. Keep hands, feet, and clothing from rotating parts.

Keep all parts in good condition and properly installed. Fix damage immediately. Replace worn or broken parts. Remove any build up of grease, oil, or debris.



Prepare for Emergencies

Be prepared if fire starts.

Keep a first aid kit and fire extinguisher handy.

Keep emergency numbers for doctors, ambulance service, hospital, and fire department near your telephone.

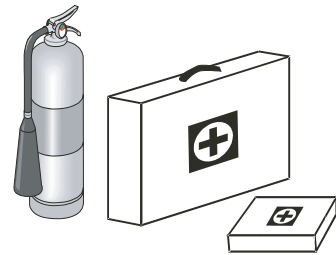

Wear Protective Clothing

Wear close fitting clothing and safety equipment appropriate to the job.

Safety glasses should be worn at all times to protect eyes from debris.

Eye Protection

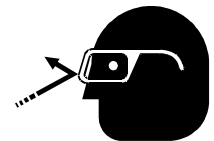

Wear gloves to protect your hands from sharp edges on plastic or steel parts.

Gloves



Wear steel toe boots to help protect your toes from falling debris.

Steel Toe Boots



A respirator may be needed if a hog house has poor ventilation. Waste fumes can be toxic.

Respirator



Remove all jewelry.

Tuck in any loose or dangling shoe strings.

Long hair should be tied up and back.

Wear hard hat to help protect your head.

Hard Hat



Decal Placement

Airlock

Install safety decals on components as shown in the decal section. Always insure that safety decals are in a place, easily readable, and in good condition. If a decal cannot be easily read for any reason or has been painted over, replace it immediately. Contact your dealer or the manufacturer to order a replacement decal free of charge.

For decal replacements contact GSI at:

1004 E. Illinois Street
Assumption, IL 62510
Ph: (217)-226-4421

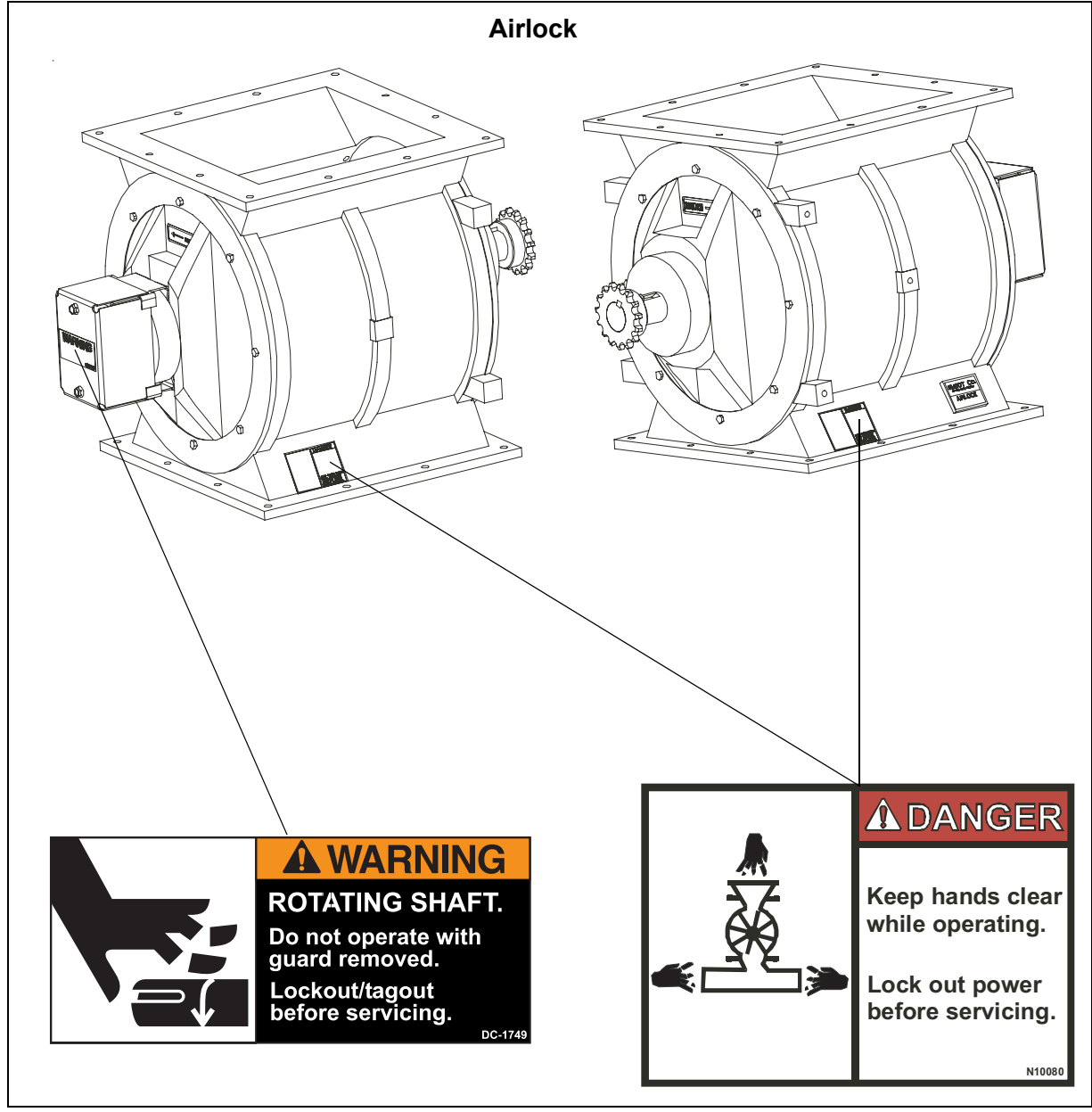

Figure 2A

2. DECALS

Airlock Base

For decal replacements contact GSI at:

1004 E. Illinois Street
Assumption, IL 62510
Ph: (217)-226-4421

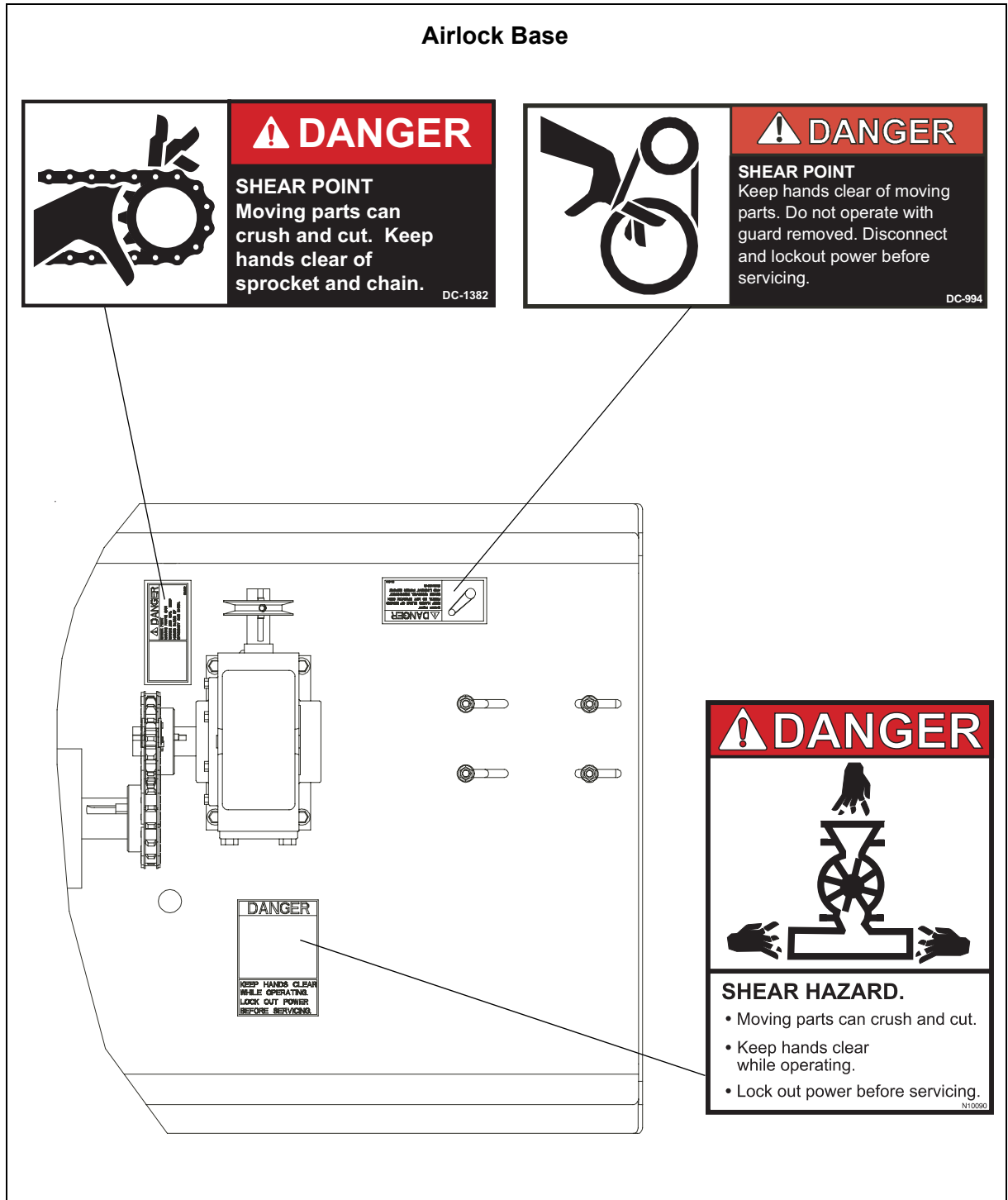

Figure 2B

Blower Base and Guard

For decal replacements contact GSI at:

1004 E. Illinois Street
Assumption, IL 62510
Ph: (217)-226-4421

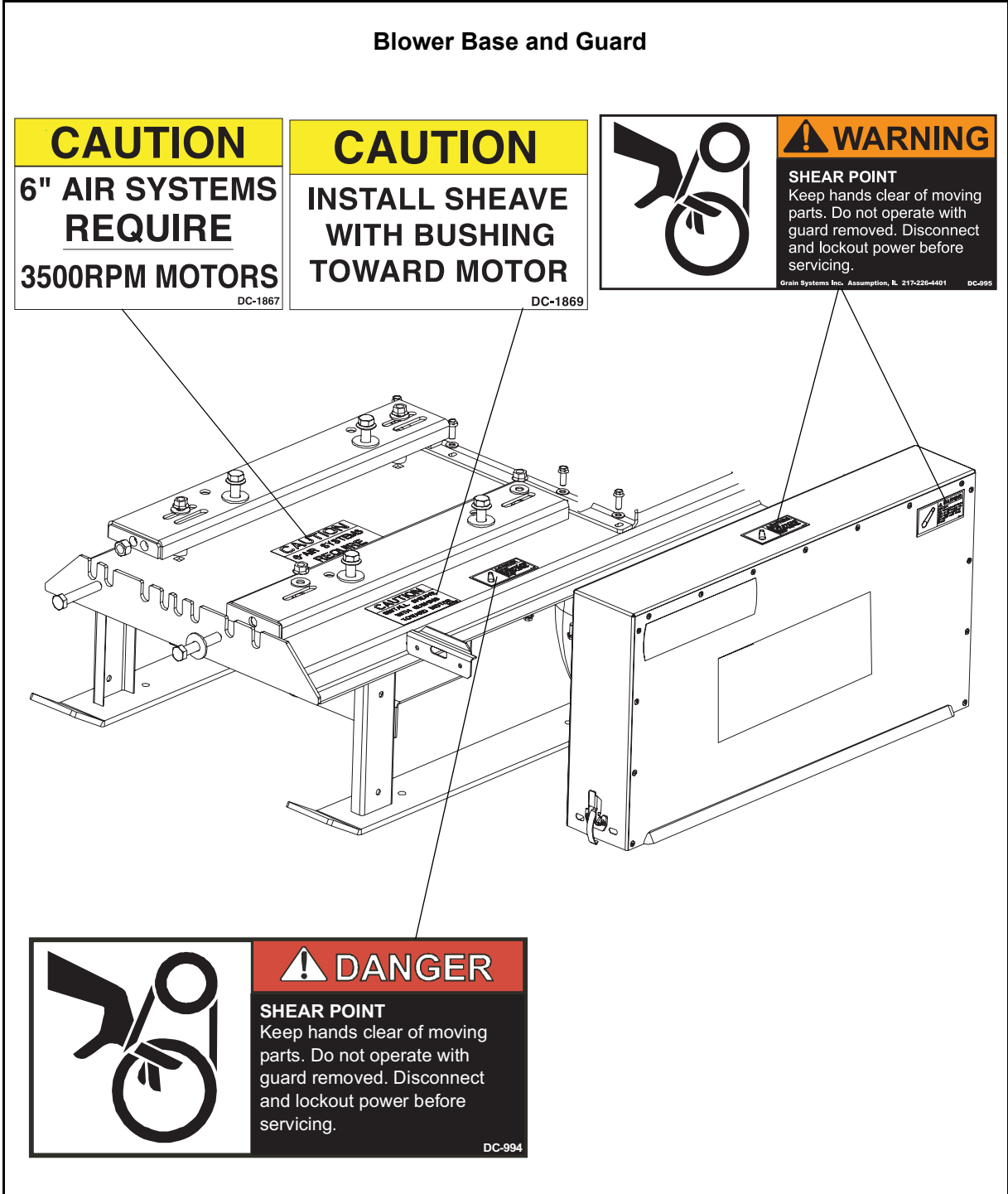

Figure 2C

2. DECALS

Airlock Guard

For decal replacements contact GSI at:

1004 E. Illinois Street
Assumption, IL 62510
Ph: (217)-226-4421

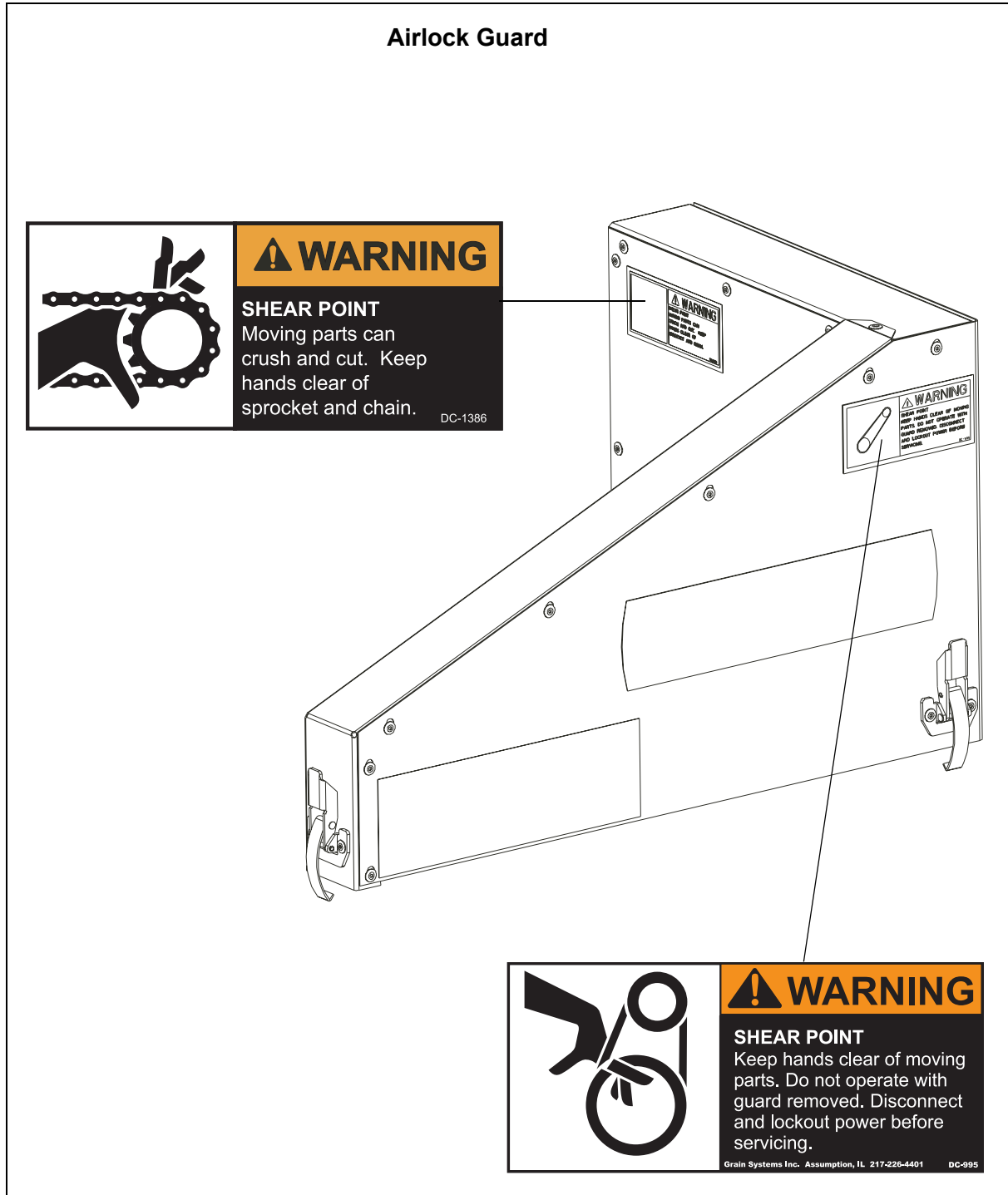

Figure 2D

Maintenance Schedule

Initial Start-Up	
<ol style="list-style-type: none"> 1. Roots-Flo Blower 2. Air Lock Gearbox 3. Air Filter 4. V-belts 5. Chain 6. Tubing System 	<ol style="list-style-type: none"> 1. Oil level with middle of sight glass (DMC #MS5389 synth. oil) 2. Oil level to check plug (SAE90) 3. Installed properly 4. Tensioned and aligned 5. Tensioned and aligned 6. All couplers tight. All tubing connections have good fit. Tubing laid out straight. Elbows fitting properly
After First 10 Hours and Daily	
<ol style="list-style-type: none"> 1. Air Filter 2. V-belts 3. Tubing 	<ol style="list-style-type: none"> 1. Check for excessive dust build-up 2. Check tension alignment 3. Check all connections for leaks and signs of separating
Weekly	
<ol style="list-style-type: none"> 1. Chain 2. Blowers & Gearbox 	<ol style="list-style-type: none"> 1. Oil 2. Check oil levels
1500 Hours (Synthetic Oil)	
<ol style="list-style-type: none"> 1. Roots-Flo and Duraflow 	<ol style="list-style-type: none"> 1. Drain oil and replace with 1.5 Qts. of DMC #MS5389 synthetic oil. (Fill to middle of sight glass)
Extended Shut Down	
Disconnect Main Power Unit <ol style="list-style-type: none"> 1. Blower 2. Airlock 3. Chain 	<ol style="list-style-type: none"> 1. Remove inlet assembly and spray oil on lobes while rotating by hand, to prevent rust. Keep hands and objects out of blower. Re-install inlet assembly 2. Coat interior with oil, while rotating by hand, to prevent rust. Re-install weather cover 3. Oil chain to prevent rust

4. AIR SYSTEM

Air System Capacities

(Dry Shelled Corn)

Effective Length (Feet)	2100 Bu/Hr 6" System (Roots-Flo)			
	40 HP Motor	50 HP Motor	60 HP Motor	75 HP Motor
50	1900	2200	2350	2500
100	1875	2175	2325	2475
150	1850	2150	2300	2450
200	1800	2100	2100	2400
250	1700	2000	2150	2300
300	1550	1850	2000	2150
350	1375	1675	1825	1975
400	1150	1450	1600	1750
450	875	1175	1325	1475
500	500	800	950	1100

Effective tube length is determined by adding the horizontal length, twice the vertical height and 10 feet for every elbow of 45° or greater. Add five feet for each elbow less than 45°. Use the horizontal run and add the vertical rise of inclined systems to calculate the effective length.

Capacity Chart

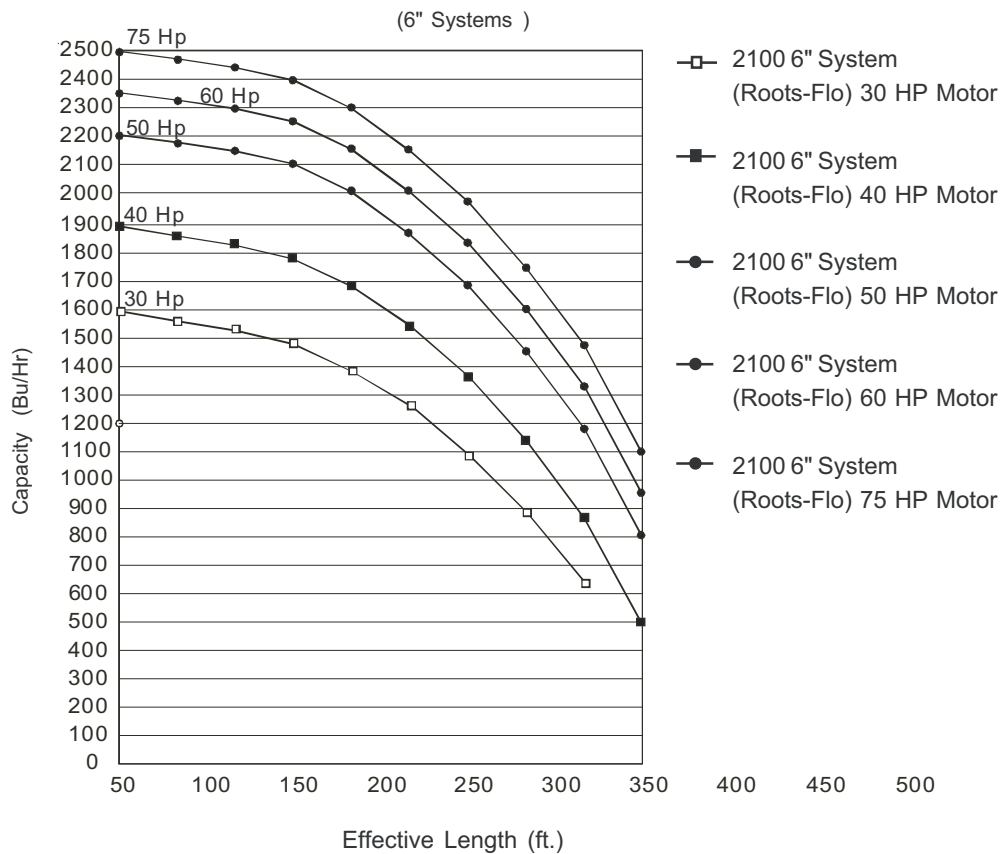

Figure 4A

Air System Installation Instructions

1. Determine the most convenient location for the airlock and blower. Take into consideration the direction of the prevailing winds. It is important to locate the blower in as clean an environment as possible. This greatly reduces the maintenance requirements on the air filter system. When the distance between the airlock and blower is over 10 feet, it is best to use galvanized pipe with short flex hose on the ends to couple the units together to keep airflow restrictions to a minimum.
2. The noise level of the blower unit can be reduced by placing the unit behind a wall, barrier, or in a small building. If this is done, make sure that the building has adequate ventilation for both air intake and cooling of the blower and motor.
3. The grain discharge chute on the airlock is assembled at the factory so that grain movement is at 90° to the length of the skid. This orientation can be changed by removing the mounting hardware at the base of the airlock and rotating the discharge chute to the preferred direction. Be sure to keep the gasket in place between the skid and the discharge chute. Note that the airlock itself is sealed to the skid surface and does not need to be moved to redirect the discharge chute.

Note: A minimum of 10 feet is needed between the airlock discharge and the first elbow in the system.

4. Determine the best routing of the galvanized steel pipe from the airlock to the storage areas. Use galvanized elbows for changing the grain direction. This will give better performance and longer life than flexhose.
5. Bolt the tube mounting brackets to the desired location using at least two (2) mounting brackets on the vertical wall and two (2) on the roof of the grain bin. The mounting brackets can be formed to match existing hole patterns in the bin.
6. Determine the number and degree of arc required in the elbows. The 90° and 60° elbows are standard - different lengths of arc can be cut from these standard elbows.
(See Page 16).

Note: A minimum of eight (8) feet between elbows is required for proper operation.

7. Cut the steel tubing to the required length and fasten it together with compression couplings. The ends must be cut square to fit properly. Make sure that the stainless steel gasket protecting sleeve is placed over the joint before tightening the coupler. Tighten the bolts on the coupler evenly or until the coupler flanges butt together. (See Page 60).
8. The steel tubing can be laid underground, on top of the ground or placed on blocks. If placed on blocks, the tubing must be supported every 15 feet. If placed underground, the tube should enter and exit the ground at a 45° angle and be coated with a protective tar to prevent corrosion.
9. Measure the distance between the airlock and blower. Use flex hose or a combination of flex hose and galvanized tubing to connect the units together. Note that the grain discharge chute on the airlock is tapered and that grain can discharge in either direction.

4. AIR SYSTEM

10. Install all tubing required to transfer grain to your storage areas.
11. To attach the deadhead deflector to the tubing, simply slide the deadhead deflector onto the tubing and tighten the clamp provided. Flexible galvanized tubing can be attached to the deadhead down spout if needed. If a cyclone is used, an elbow and mounting brackets are needed.
12. Select a location to mount the electrical control box that is accessible and easily reached should shut down of unit be necessary. It should be close enough to the blower to run the 30 feet of rubber pressure hose between the blower and the control box. Otherwise, a longer length of hose must be ordered.
13. Before wiring or operating the Air System unit, read the control box description on [Pages 21 to 32](#) to understand the operation of the Air System control box. If the control box is to be wired to remote equipment, review the wiring diagrams for proper hook-up.

Air System Capacities

(Dry Shelled Corn)

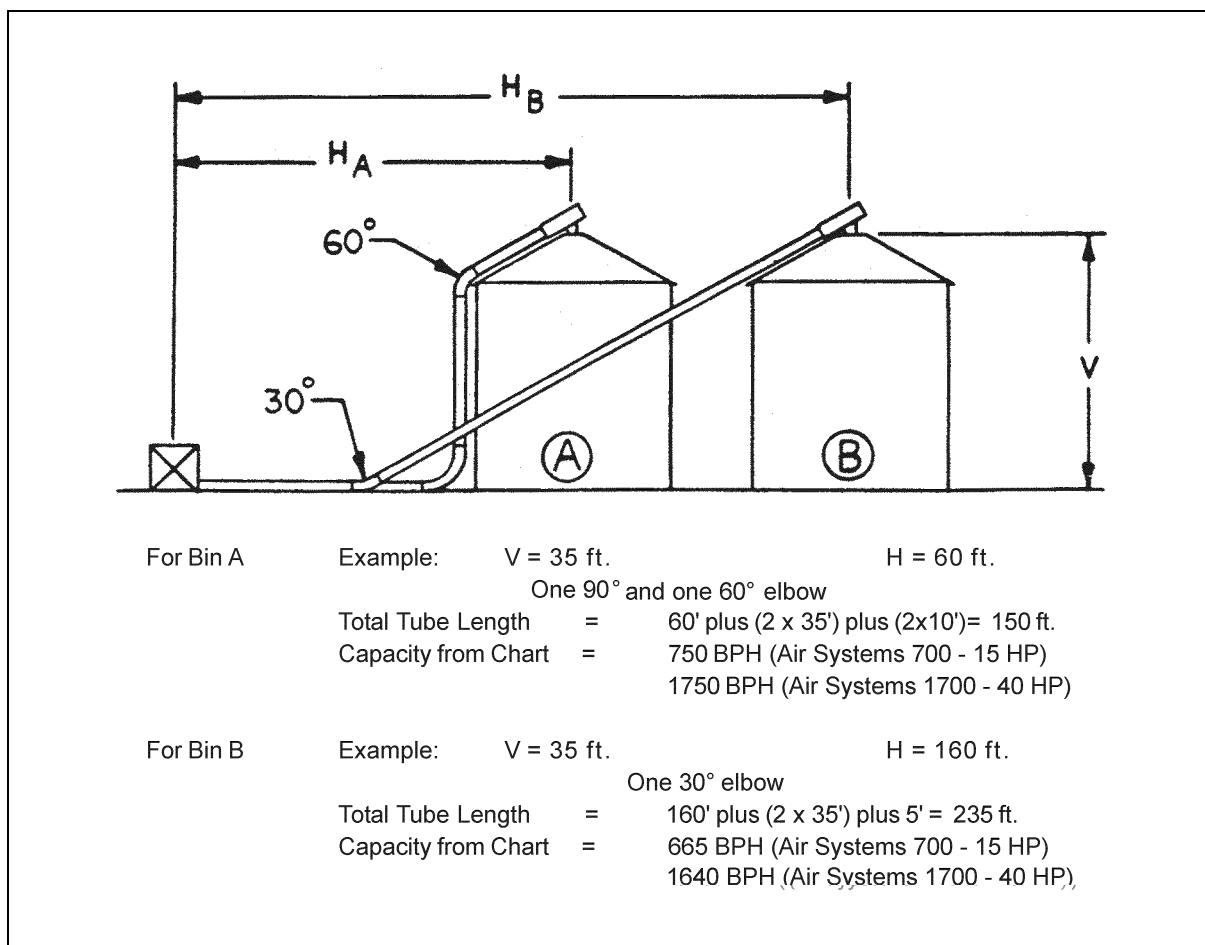

Figure 4B

Air System Tubing Dimensions

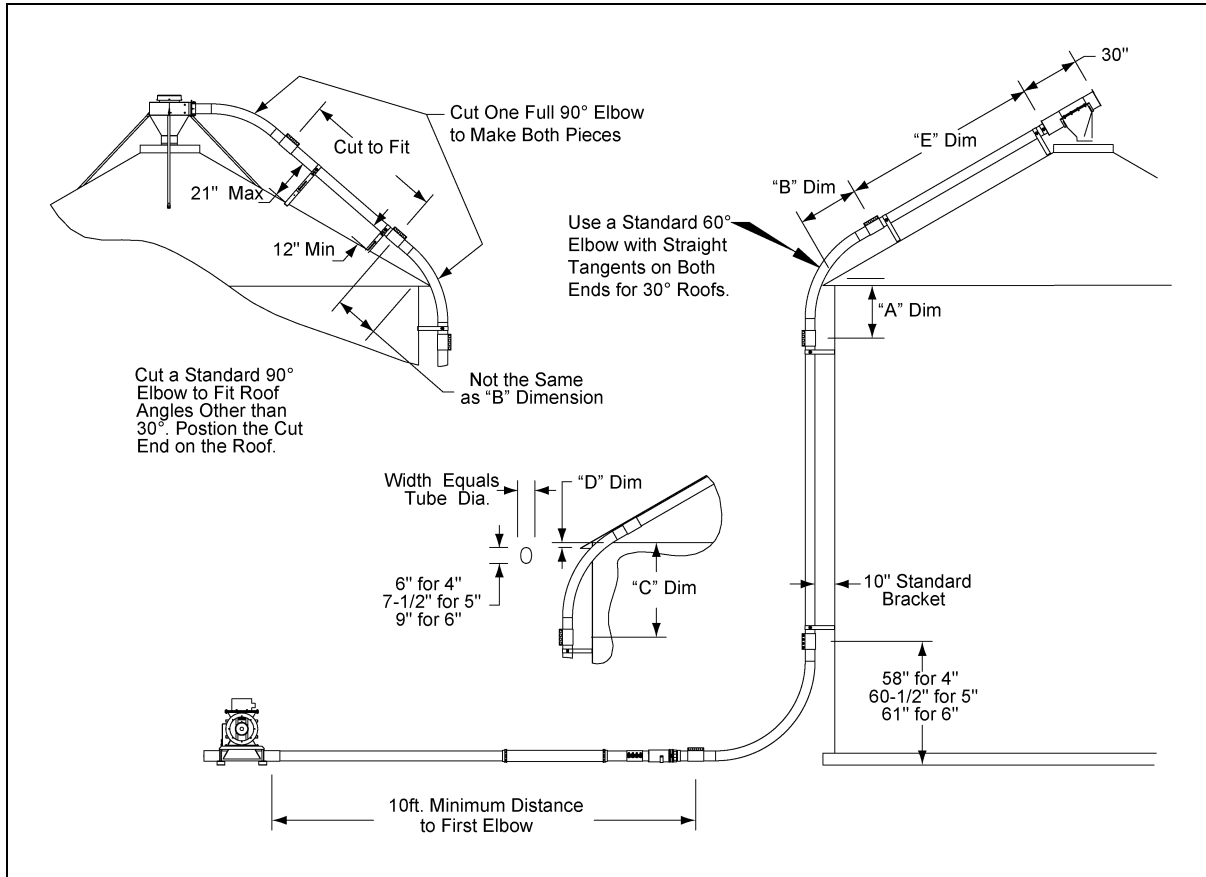

Figure 4C

System Size	Roof Angle	Reference Dimension												
		A	B	C	D	E*								
						18' Dia.	21' Dia.	24' Dia.	27' Dia.	30' Dia.	33' Dia.	36' Dia.	42' Dia.	48' Dia.
4"	25	31"	23"	47-1/2"	5-3/4"	7' 1"	8' 9"	10' 5"	12' 1"	13' 9"	15' 5"	17' 1"	20' 5"	23' 9"
	30	29"	29"	46"	3-1/2"	7' 1"	8' 9"	10' 5"	12' 1"	13' 9"	15' 5"	17' 1"	20' 5"	23' 9"
	35	27"	19"	45"	2-1/2"	8' 6"	10' 2"	11' 10"	13' 6"	15' 2"	16' 10"	18' 6"	21' 10"	25' 2"
5"	25	32-1/2"	22-1/2"	50"	4-1/2"	7'	8' 9"	10' 6"	12' 3"	14'	15' 9"	17' 6"	21'	24' 6"
	30	30-1/2"	30-1/2"	49"	3-1/4"	6' 10"	8' 7"	10' 4"	12' 1"	13' 10"	15' 7"	17' 4"	20' 10"	24' 4"
	35	28-1/2"	18-1/2"	48"	2-1/4"	8' 6"	10' 3"	12'	13' 9"	15' 6"	17' 3"	19'	22' 6"	26'
6"	25	32-1/4"	22-1/4"	51"	4-1/2"	7' 3"	9' 1"	10' 11"	12' 9"	14' 7"	16' 5"	18' 3"	21' 11"	25' 7"
	30	30-1/4"	30"	50"	3"	7' 1"	8' 11"	10' 9"	12' 7"	14' 5"	16' 3"	18' 1"	21' 9"	25' 5"
	35	28-1/4"	18"	49"	2"	8' 8"	10' 6"	12' 4"	14' 2"	16'	17' 10"	19' 9"	22' 4"	27'

* Add 10" to E dimension if roof elbow has been cut from a 90° Elbow.

4. AIR SYSTEM

Elbow Angle Measurements

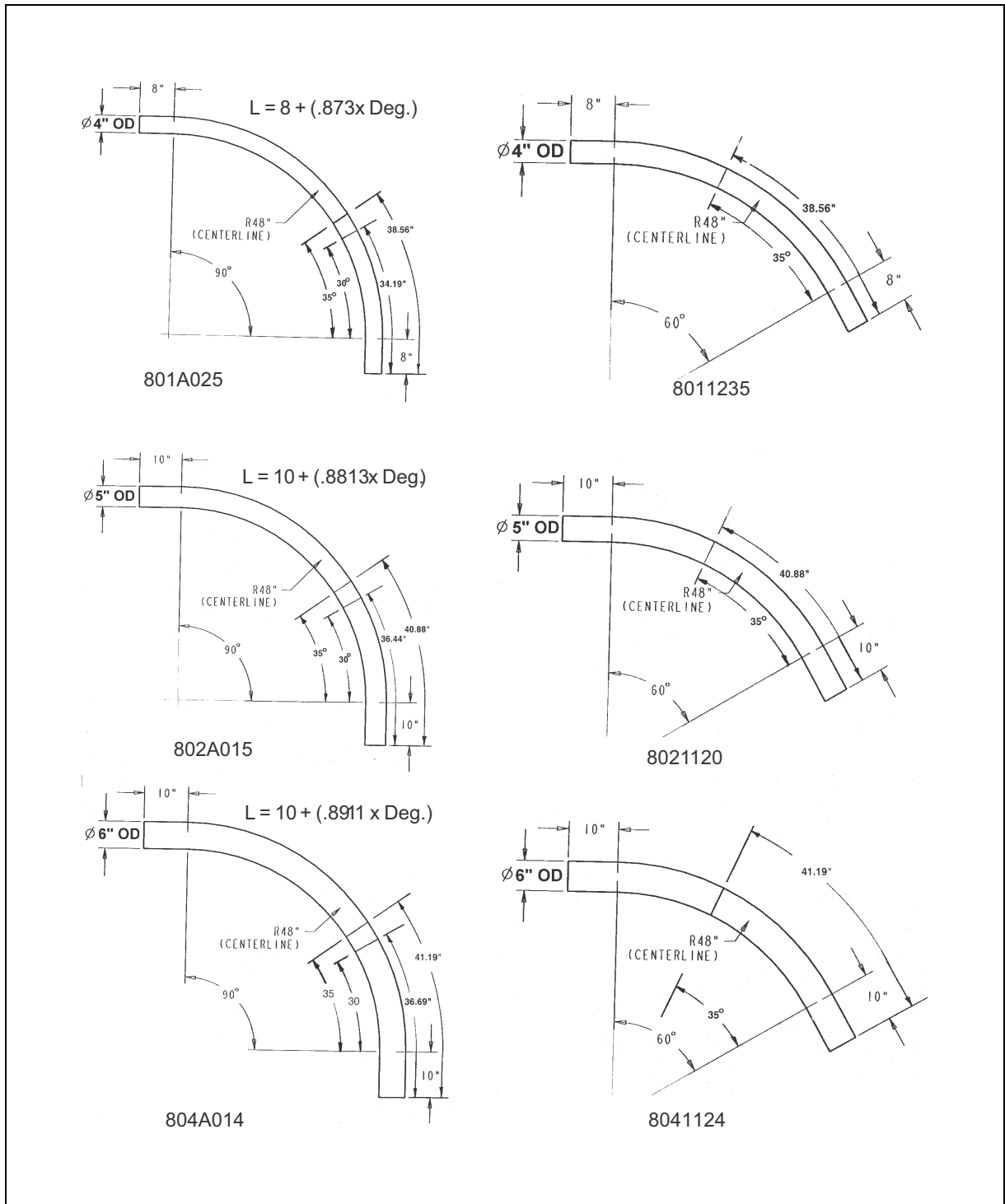

Figure 4D

Air System Set-Up Procedure

1. The air filter extension tube and housing are connected to the blower inlet by a compression coupler (See [Figure 4E](#), [Figure 4F](#) and [Figure 4G](#)). For extended filter life, if the pneumatic system is being operated in extremely dirty conditions, a longer extension tube can be used between the blower inlet and the air filter. BE SURE the air filter is positioned so that routine inspection and service can be performed.
2. Place the air filter element with pre-filter on the base and cover with the filter canister using the 3/8" wing nut and washer. The wing nut does not need to be more than finger tight (See [Figure 4F](#) and [Figure 4G](#)).

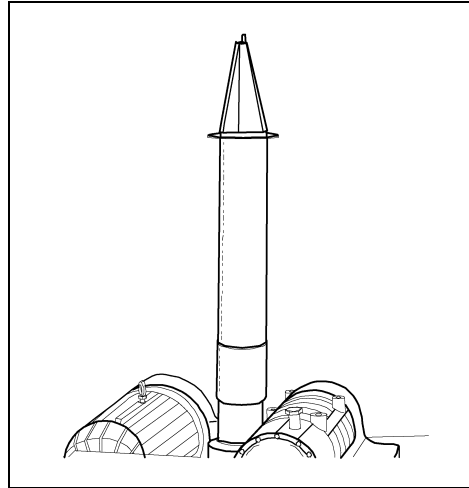

Figure 4E

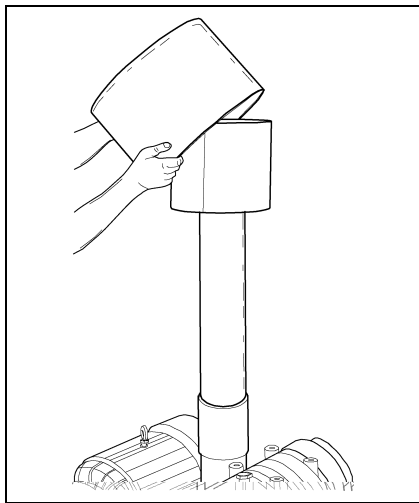

Figure 4F

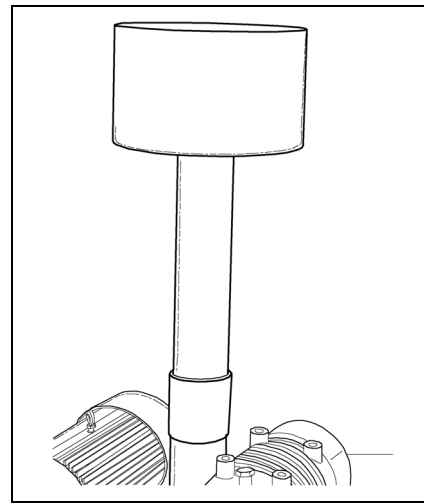

Figure 4G

3. Check the motor name plate for the correct motor frame size. Then refer to the Drawing on [Pages 20](#) to determine proper mounting holes and spacing of the motor mount channel. The spacing of the motor mount channels is changed by moving the channel to the proper notch cut into the main base of the blower platform. See [Figure 4H](#) and the Drawing on page 20. Finish by bolting the motor securely to the channels. Leave the four 1/2" carriage bolts loose, holding the channels to the main frame.
4. Place the pulley and taper lock bushing onto the motor and align it with the blower pulley. (See [Figure 4I](#)).

4. AIR SYSTEM

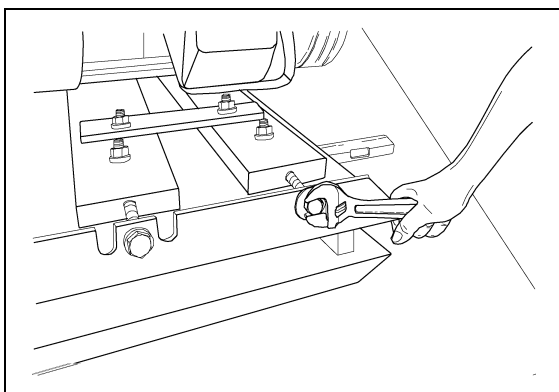

Figure 4H

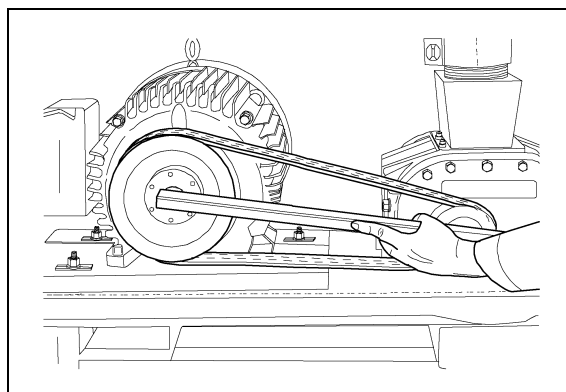

Figure 4I

5. Place the matching set of V-belts on the pulleys. Tighten the belts by evenly turning the cap screws clockwise. Belts should have 3/8" deflection at ten pounds pressure per belt. (See Figure 4H).
6. Keeping the motor in proper alignment is necessary and can be accomplished by using an open end wrench to turn the nut on the opposite motor mount channel, moving the channel either direction until proper alignment is achieved. Squaring up the motor can change the tension of the belts. Recheck alignment and tension. Finish Step 4 by tightening the four 1/2" bolts left loose earlier. (See Figure 4J and Figure 4K).

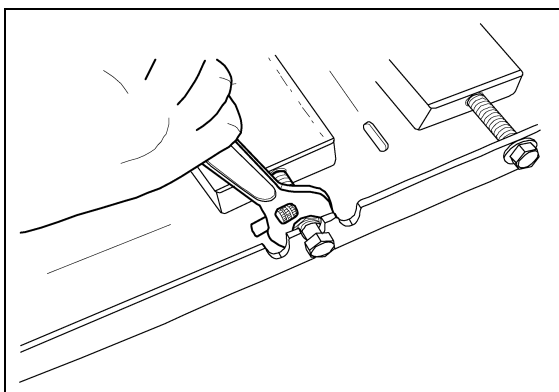

Figure 4J

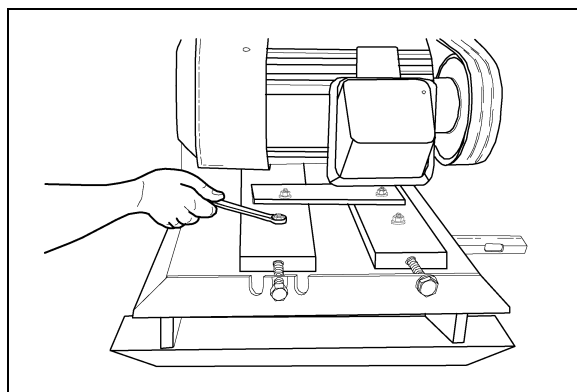

Figure 4K

7. Check the oil level of the blower. The oil level should be at the center of the sight glass. Add part number #MS5389, if required, through the breather plug on top of the blower case. (See Figure 4L). See the Maintenance Schedule on [Pages 11](#) for the frequency of oil changes.
8. Using four (4) 5/16" x 1" carriage bolts, washers, and nuts, mount the motor to the airlock deck. Place the 3-1/4" OD A-Groove Pulley on to the motor shaft and align to pulley on reducer. (See Figure 4M).

4. AIR SYSTEM

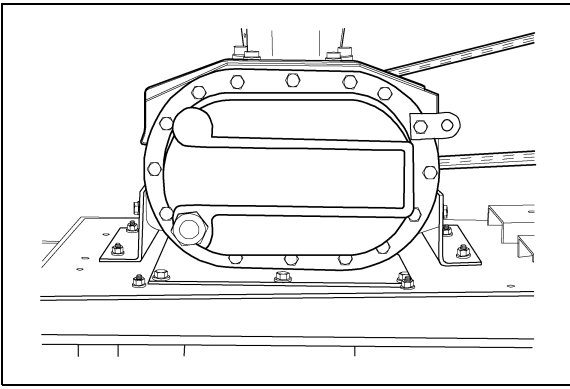

Figure 4L

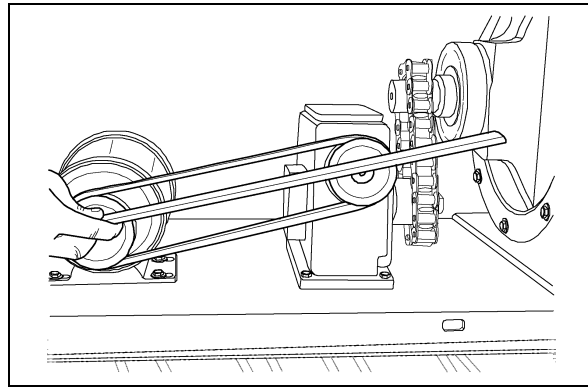

Figure 4M

9. Next, place the A-31 belt onto the pulleys. Tighten the belt to its proper tension of $\frac{3}{8}$ " deflection at ten pounds of pressure by turning the $\frac{3}{8}$ " cap screw as shown in [\(See Figure 4N\)](#). Tighten the four $\frac{5}{16}$ " nuts on the motor base. Replace the belt shield.

10. Check the oil level in the gearbox by removing the plug and noting if the oil is at this level. Add SAE 80-90 gear lubricant if required. [\(See Figure 4O\)](#).

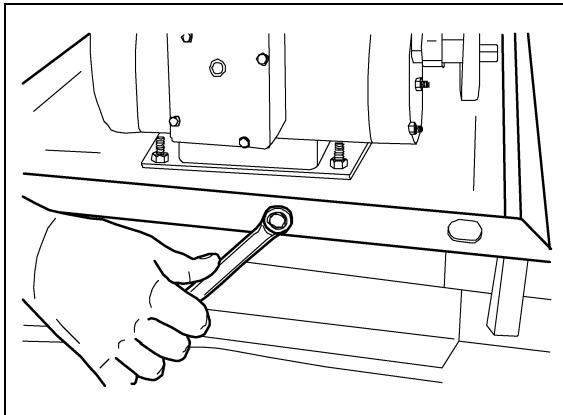

Figure 4N

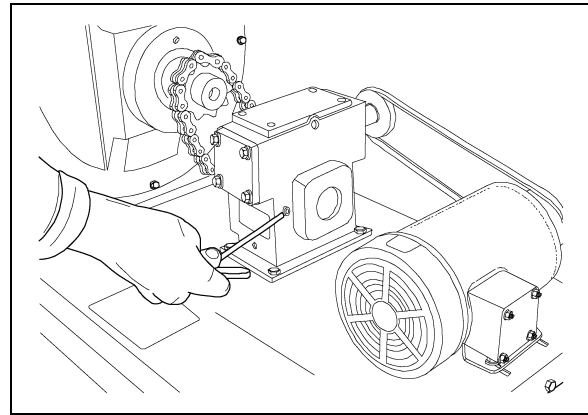

Figure 4O

11. Remove $\frac{1}{4}$ " pipe plug in gate valve pipe. Install gauge assembly and attach air hose. [\(See Figure 4P\)](#).

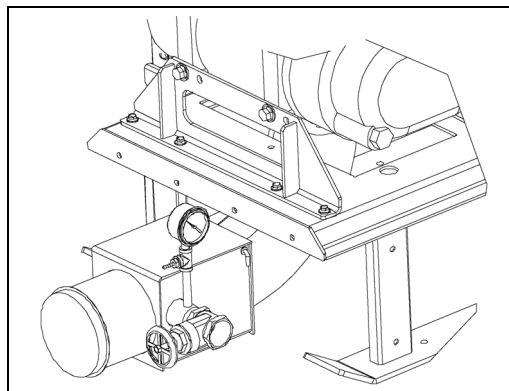

Figure 4P

Note: THE SET-UP OF THE PNEUMATIC AIR SYSTEM IS NOW COMPLETE.

4. AIR SYSTEM

6" Air System 2100 Motor Mounting Locations

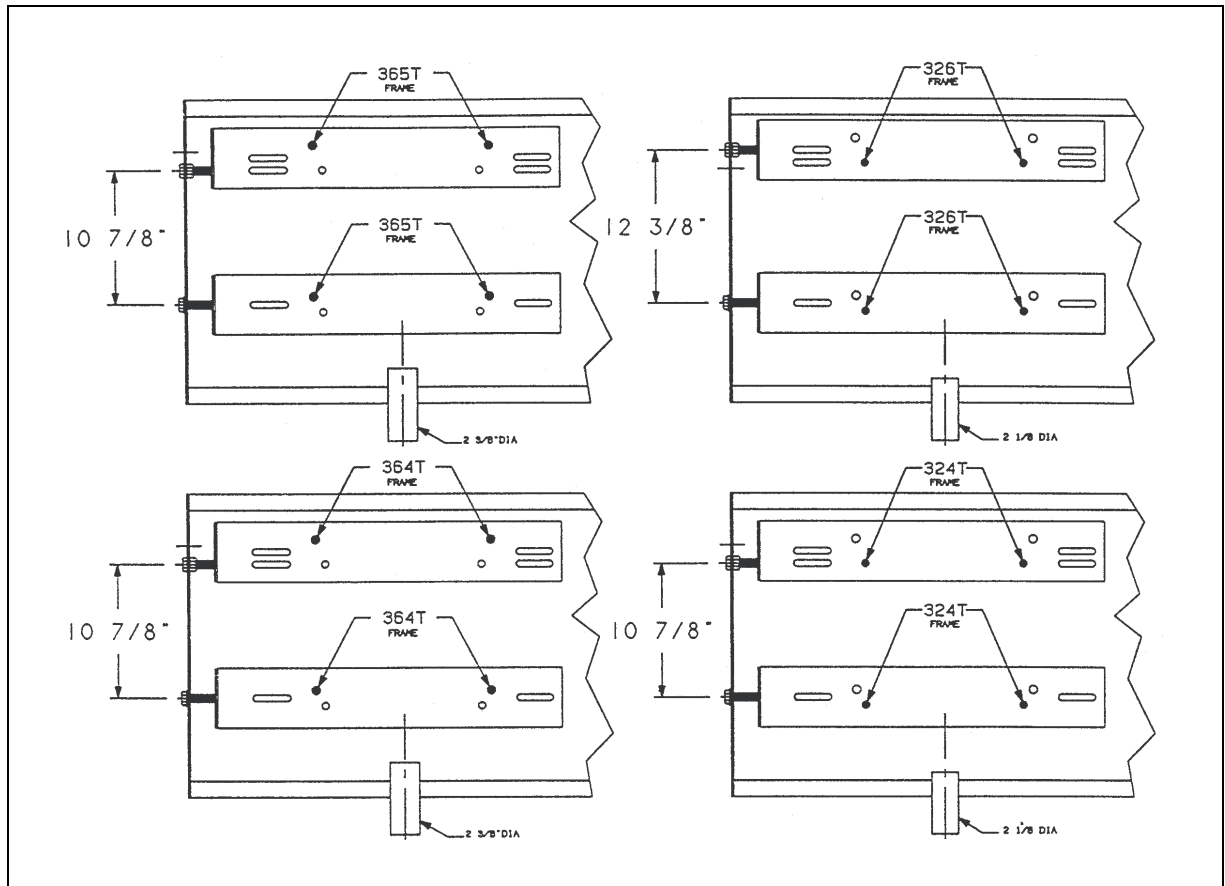

Figure 4Q

6" Air Systems Motor Chart

Motor Part #	Horse power	Frame Size	Shaft Diam.	Voltage	Phase
CH-5582	40	324TS	1-7/8	230/440	3
CH-5583	50	326TS	1-7/8	230/440	3
6000-3-3500	60	364TS	1-7/8	230/440	3
7500-3-3500	75	365TS	1-7/8	230/440	3

Note: Motor rotation is counter-clockwise as viewed from the shaft end.

⚠ CAUTION ⚠

Be sure to install motor sheave so bushing is on the inside towards the motor.

Air Systems Control Box Definitions

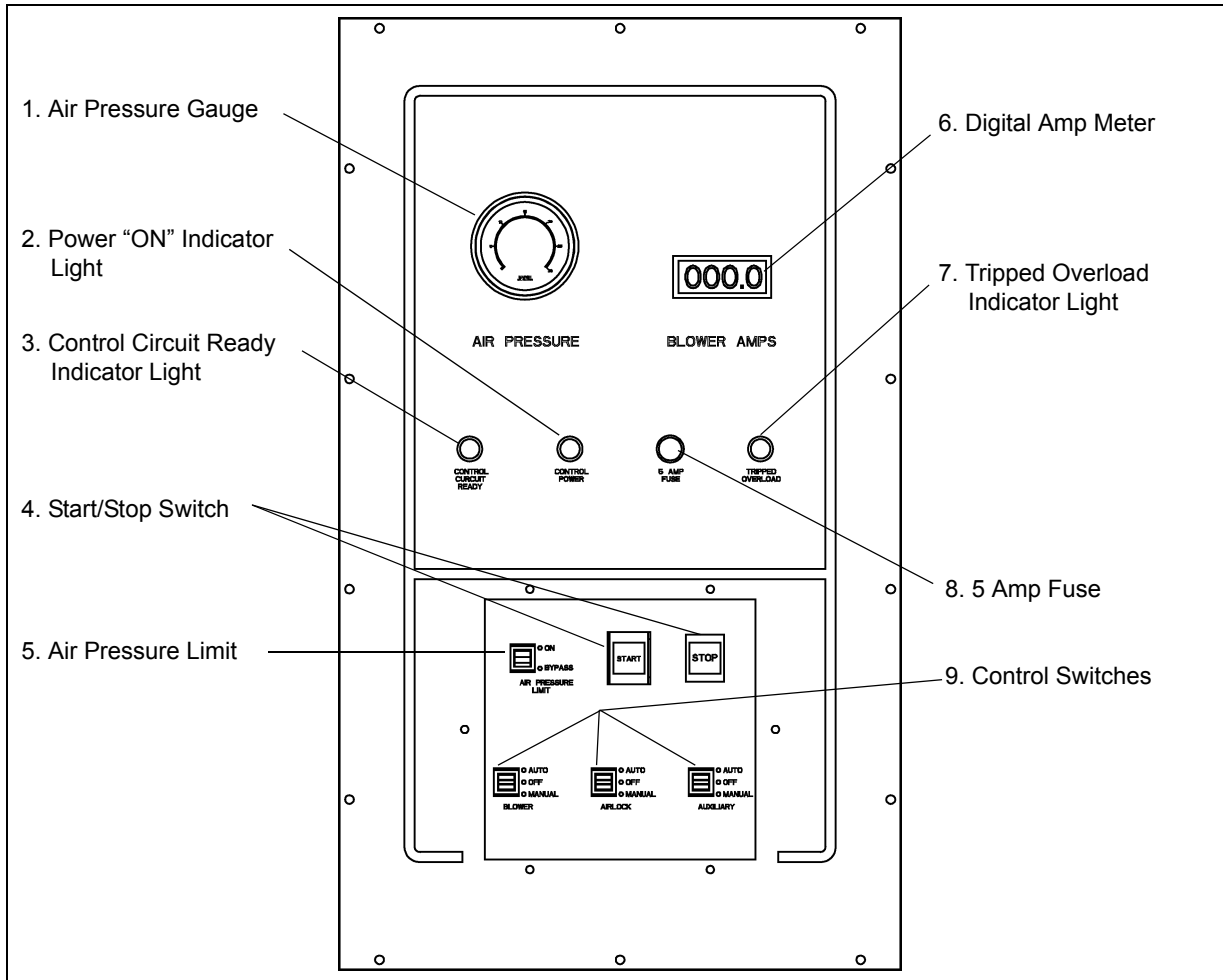

Figure 4R

1. **Air Pressure Gauge:** This gauge indicates the system air pressure.
2. **Power-ON Indicator Light:** This lamp will light up when power is supplied to the control box.
3. **Control Circuit Ready Indicator Light:** This lamp will light up when the start button has been pushed and all control circuits are completed. When lit and in the automatic mode, the air system will run whenever it receives a signal to start.
4. **Start-Stop Switch:** The start button must be pushed before any part of the Air System can be run. Pushing the stop button will immediately stop all functions.
5. **Air Pressure Limit control Switch:** When in the “ON” position, this switch will allow the air pressure switch to immediately shut down the air system whenever the air pressure exceeds preset conditions.
6. **Amp Meter:** The amp meter measures the current flow to the blower motor.
7. **Tripped Overload Indicator Light:** This lamp will light up when any of the motor thermal overloads in the control box has tripped. The overloads for all three circuits (Aux, Airlock, and Blower) must have thermal overloads installed to operate the system. (See Thermal Unit Chart on [Pages 23](#)).

4. AIR SYSTEM

8. **5 Amp Fuse:** A five (5) amp fuse protects the electrical components in the control box.
9. **Control Switches:** The operation of the blower, airlock and auxiliary equipment of the air system is controlled by placing these switches in the “AUTO”, “MANUAL” or “OFF” position.
10. **Automatic Control Terminals:** When the air system is ready to run (i.e., the control ready light is on), the system can then be started and run by completing the circuit between terminals one (1) and two (2). The blower, airlock or auxiliary equipment will not run in the automatic mode unless terminals one (1) and two (2) are connected. For example, a closing set of contacts in a dryer control box would complete the circuit between terminals one (1) and two (2) and automatically start the air system. (See Figure 4S)

⚠ WARNING ⚠

No voltage should be supplied to terminals one (1) and two (2). See the diagram on [Pages 26 & Pages 27](#) and [See Figure 4S](#).

11. **Remote Shut-Down control:** A remote piece of equipment can be caused to shutdown with the air system by putting terminals three (3) and four (4) in series with the control circuit of the remote equipment. This circuit has a maximum current rating of 10 amps. The circuit between terminals three (3) and four (4) is closed whenever the control circuit ready light is on, regardless of the position of the control switches. (“AUTO”, “OFF” or “ON”) See the Diagram on [Pages 26](#), [Pages 27](#) and [Pages 32](#).

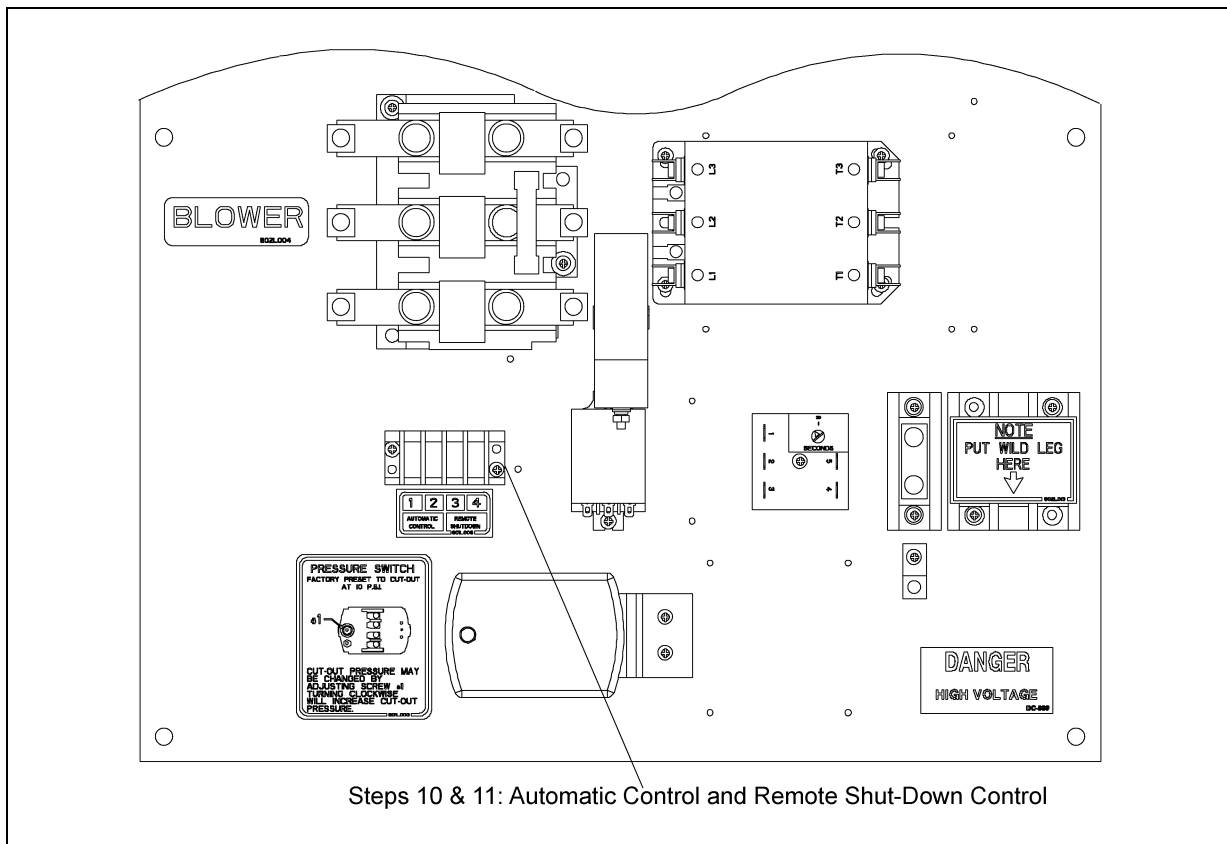

Figure 4S

5. THERMAL UNIT CHART

Air System Control Box - Thermal Unit Chart

SINGLE MOTOR	1EL0861 #B 3.00 THERMAL UNIT	1EL0859 #B 4.15 THERMAL UNIT	1EL0769 #B 6.90 THERMAL UNIT	1EL0762 #B 7.70 THERMAL UNIT	1EL0767 #B 9.10 THERMAL UNIT	1EL0761 #B 14 THERMAL UNIT	1EL0794 #CC 68.5 THERMAL UNIT	1EL0800 #CC 103 THERMAL UNIT	1EL0791 #CC 112 THERMAL UNIT	1EL0808 #CC 143 THERMAL UNIT	1EL0812 #CC 156 THERMAL UNIT	1EL0809 #CC 180 THERMAL UNIT
6" AIR SYSTEM 40HP, 230V, 3PH			3		3						3	
6" AIR SYSTEM 40HP, 440V, 3PH	3	3					3					
6" AIR SYSTEM 50HP, 230V, 3PH			3			3						3
6" AIR SYSTEM 50HP, 440V, 3PH	3			3					3			
6" AIR SYSTEM 60HP, 230V, 3PH			3			3						SET. 63
6" AIR SYSTEM 60HP, 440V, 3PH	3			3				3				
6" AIR SYSTEM 75HP, 230V, 3PH			3			3						SET. 70
6" AIR SYSTEM 75HP, 440V, 3PH	3			3						3		

6. WIRING DIAGRAMS

Overload Relay Settings for 2EL0284 ADJ.

Overload Relay (used on 60 & 75 HP - 230 V)

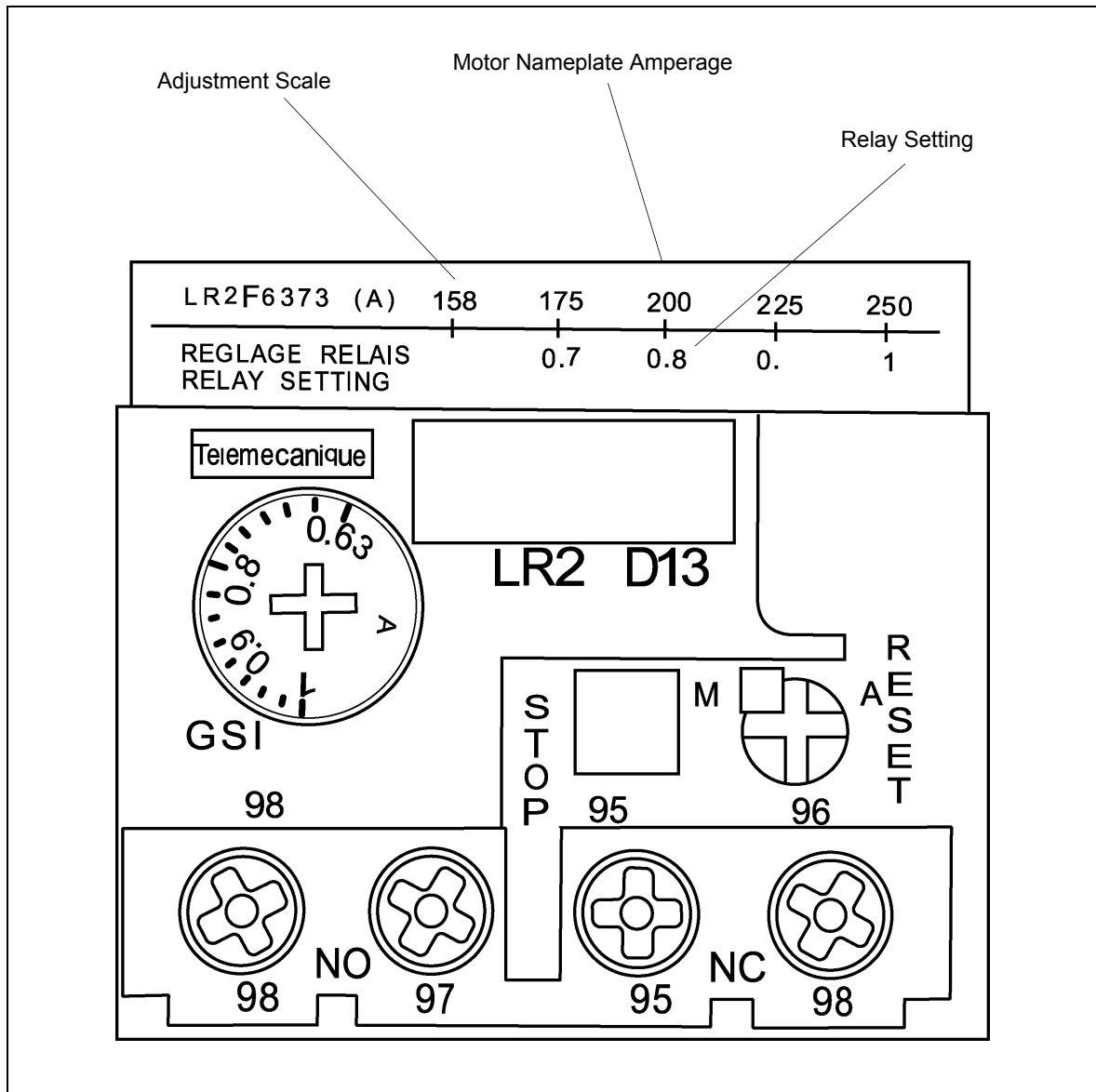

Figure 6A

2EL0284 relay must be adjusted to provide protection to the blower motor. The proper relay setting is determined by matching the relay setting with the motor nameplate amperage on the scale that is attached to the overload adjustment block. Use a small screw driver to turn the adjustment dial and align the proper relay setting with the indicator mark. The example above shows a motor with a nameplate amperage of 200 amps protected by using a relay setting of 0.8. This device should also be set to have a "MANUAL" reset. The small blue button with a phillips head should be in the "UP" position. If not, lift open the clear plastic window and turn the blue button 1/4 turn to the left. Close the window to lock the reset in the "MANUAL" position.

Thermal Overload Information

Note: When installed correctly, the size printed on the overload will be readable. The Square D overload charts should be used to size the heater to your motor Amps.

SQUARE D® OVERLOAD RELAY Class 9065, Type S 3 Element Melting Alloy 26 Amp. Max. Motor Rating Symmetrical Ampere, 600 Volts Maximum.

Suitable For Use On A Circuit Capable of Delivering Not More Than 5000 rms Symmetrical Amperes, 600 Volts Maximum.

OVERLOAD — RELAY THERMAL UNITS

WARNING: If burnout of an overload relay thermal unit occurs, the thermal unit must be replaced to provide continued protection against fire and shock hazard.

AVERTISSEMENT:

Si un élément thermique grille, il doit être remplacé. Pour continuer à protéger contre les incendies et les chocs, les unités thermiques doivent être remplacées. Pour continuer à protéger les moteurs ayant une service factor de 1.0, sélectionnez les unités thermiques de la table en utilisant 90% du courant nominal du moteur.

For continuous-rated motors having service factors of 1.15 to 1.25, select thermal units directly from table using 100% of full-load current shown on motor nameplate. For continuous-rated motors having a service factor of 1.0, select thermal units from table using 90% of full-load current shown on motor nameplate.

MOTOR FULL-LOAD CURRENT (AMP.)	THERMAL UNIT NO.	MAXIMUM FUSE RATING (AMP.)	MOTOR FULL-LOAD CURRENT (AMP.)	THERMAL UNIT NO.	MAXIMUM FUSE RATING (AMP.)
0.28-0.31	B 044	0.6	3.09-3.81	B 550	7
0.32-0.35	B 051	0.6	3.88-4.14	B 525	8
0.36-0.38	B 057	0.8	4.15-4.73	B 600	9
0.39-0.46	B 063	0.8	4.74-5.28	B 770	10
0.47-0.55	B 071	1	5.29-5.68	B 820	10
0.56-0.62	B 081	1.25	5.65-6.39	B 910	12
0.63-0.67	B 093	1.4	6.07-7.43	B 107	12
0.68-0.75	B 103	1.4	7.44-8.54	B 115	15
0.76-0.84	B 116	1.6	8.56-9.40	B 128	17.5
0.85-0.95	B 130	1.8	9.41-10.0	B 14	20
0.96-1.05	B 140	2	10.11-11	B 15	20
1.10-1.21	B 167	2.25	11.3-12.5	B 17.5	25
1.22-1.35	B 188	2.5	12.6-13.5	B 19.5	25
1.36-1.53	B 200	3	13.6-15.3	B 21	30
1.54-1.73	B 240	3.2	15.5-17.3	B 25	30
1.74-1.90	B 265	3.5			
1.91-2.14	B 300	4			
2.15-2.34	B 330	4.5			
2.35-2.67	B 370	5			
2.68-3.22	B 415	5.6			
3.23-3.46	B 455	7			

Branch-circuit fuse rating must comply with applicable electrical codes and must not exceed the maximum fuse rating shown opposite the thermal unit selected. Fuses may need to be of the time delay type to permit motor starting. Class KS or Class R fuses are recommended. Non-time delay fuses whose rating does not exceed 300 percent of motor full-load current may be used. Maximum allowable thermal magnetic (inverse time) circuit breaker rating is 225 percent of motor full-load current unless a lower rating is required by applicable electrical codes. Trip current setting for the thermal unit selected. Instructions given above assume that the motor and the overload relay are located in approximately the same ambient temperature. For other conditions consult Square D.

SQUARE D® OVERLOAD RELAY Class 9065, Type S 3 Element Melting Alloy 45 Amp. Max. Motor Rating Symmetrical Ampere, 600 Volts Maximum.

Suitable For Use On A Circuit Capable of Delivering Not More Than 5000 rms Symmetrical Amperes, 600 Volts Maximum.

OVERLOAD — RELAY THERMAL UNITS

WARNING: If burnout of an overload relay thermal unit occurs, the complete overload relay must be replaced to provide continued protection against fire and shock hazard.

AVERTISSEMENT:

Si un élément thermique grille, il doit être remplacé. Pour continuer à protéger contre les incendies et les chocs, les unités thermiques doivent être remplacées. Pour continuer à protéger les moteurs ayant une service factor de 1.0, sélectionnez les unités thermiques de la table en utilisant 90% du courant nominal du moteur.

For continuous-rated motors having service factors of 1.15 to 1.25, select thermal units directly from table using 100% of full-load current shown on motor nameplate. For continuous-rated motors having a service factor of 1.0, select thermal units from table using 90% of full-load current shown on motor nameplate.

MOTOR FULL-LOAD CURRENT (AMP.)	THERMAL UNIT NO.	MAXIMUM FUSE RATING (AMP.)	MOTOR FULL-LOAD CURRENT (AMP.)	THERMAL UNIT NO.	MAXIMUM FUSE RATING (AMP.)
3.38-3.85	B 455	7	12.1-13.5	B 17.5	25
3.86-4.07	B 550	8	13.6-14.6	B 19.5	30
4.08-4.36	B 625	9	14.7-16.7	B 22	30
4.37-5.19	B 690	9	16.8-19.9	B 25	35
5.20-5.38	B 770	10	17.0-19.1	B 28	35
5.60-5.88	B 820	12	21.7-24.1	B 32	45
5.98-6.28	B 910	12	24.2-27.6	B 36	50
6.78-7.91	B 102	15	27.7-31.2	B 40	60
7.92-9.12	B 115	17.5	31.3-35.5	B 45	60
9.13-10.0	B 128	20	35.6-37.8	B 50	60
10.1-10.7	B 14	20	37.9-41.5	B 55	60
10.2-12.0	B 15	20	41.6-55.9	B 52	60

Branch-circuit fuse rating must comply with applicable electrical codes and must not exceed the maximum fuse rating shown opposite the thermal unit selected. Fuses may need to be of the time delay type to permit motor starting. Class KS or Class R fuses are recommended.

Non-time delay fuses whose rating does not exceed 300 percent of motor full-load current may be used. Maximum allowable thermal magnetic (inverse time) circuit breaker rating is 225 percent of motor full-load current unless a lower rating is required by applicable electrical codes. For full-load currents below 6.67 amperes, a 15 ampere circuit breaker may be used. Trip current setting for the thermal unit selected. Instructions given above assume that the motor and the overload relay are located in approximately the same ambient temperature. For other conditions consult Square D.

SQUARE D® OVERLOAD RELAY Class 9065, Type S 3 Element Melting Alloy 86 Amp. Max. Motor Rating Symmetrical Ampere, 600 Volts Maximum.

Suitable For Use On A Circuit Capable of Delivering Not More Than 5000 rms Symmetrical Amperes, 600 Volts Maximum.

OVERLOAD — RELAY THERMAL UNITS

WARNING: If burnout of an overload relay thermal unit occurs, the thermal unit must be replaced to provide continued protection against fire and shock hazard.

AVERTISSEMENT:

Si un élément thermique grille, il doit être remplacé. Pour continuer à protéger contre les incendies et les chocs, les unités thermiques doivent être remplacées. Pour continuer à protéger les moteurs ayant une service factor de 1.0, sélectionnez les unités thermiques de la table en utilisant 90% du courant nominal du moteur.

MOTOR FULL-LOAD CURRENT (AMP.)	THERMAL UNIT NO.	MAXIMUM FUSE RATING (AMP.)	MOTOR FULL-LOAD CURRENT (AMP.)	THERMAL UNIT NO.	MAXIMUM FUSE RATING (AMP.)
15.5-17.4	CC 20.9	35	40.6-43.7	CC 54.5	90
17.5-18.9	CC 22.8	35	43.8-47.0	CC 58.4	90
19.0-20.5	CC 24.6	40	47.1-50.3	CC 64.3	100
20.6-22.0	CC 26.3	45			600V, 250V.
22.1-23.8	CC 28.8	45			
23.9-25.8	CC 31.0	50			
25.7-27.7	CC 33.3	50	51.6-54.5	CC 68.5	100
27.6-29.7	CC 35.6	50	54.6-58.1	CC 74.6	100
29.6-32.2	CC 38.5	60	58.4-63.1	CC 81.5	100
32.3-34.7	CC 42.7	70	63.2-68.4	CC 87.7	100
34.8-37.3	CC 46.6	70	68.5-73.8	CC 94.0	100
37.4-40.5	CC 50.1	80	73.9-78.9	CC 103	100
			79.0-86.0	CC 112	125

Branch-circuit fuse rating must comply with applicable electrical codes and must not exceed the maximum fuse rating shown opposite the thermal unit selected. Fuses may need to be of the time delay type to permit motor starting. Class KS or Class R fuses are recommended.

Non-time delay fuses whose rating does not exceed 300 percent of motor full-load current may be used. Maximum allowable thermal magnetic (inverse time) circuit breaker rating is 200 percent of motor full-load current unless a lower rating is required by applicable electrical codes. Trip current setting for the thermal unit selected. Instructions given above assume that the motor and the overload relay are located in approximately the same ambient temperature. For other conditions consult Square D.

Figure 6B

6. WIRING DIAGRAMS

Schematic With Digital Amp Meter

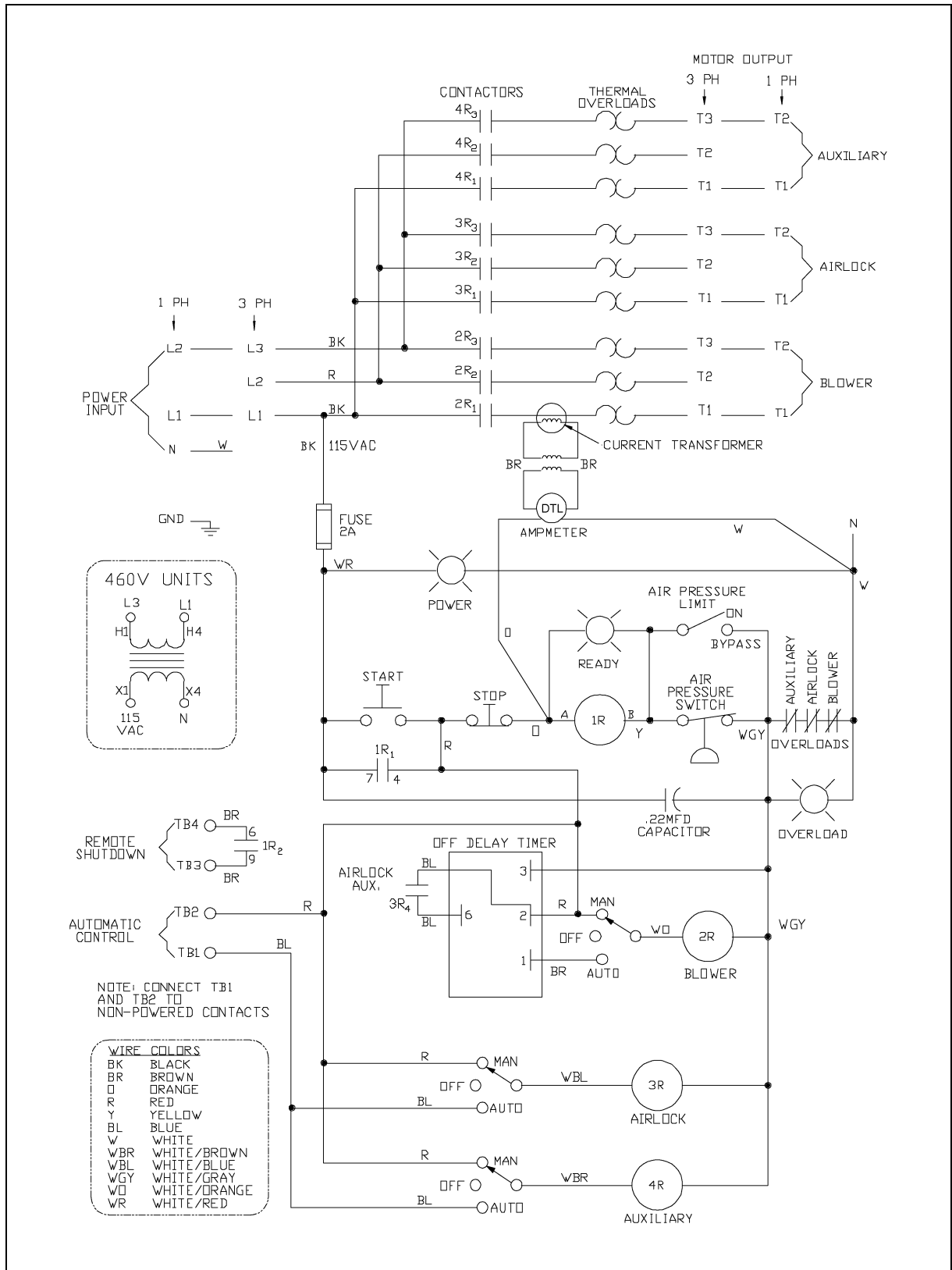

6. WIRING DIAGRAMS

Schematic with Analog Amp Meter - Using 2EL0273 Control Relay

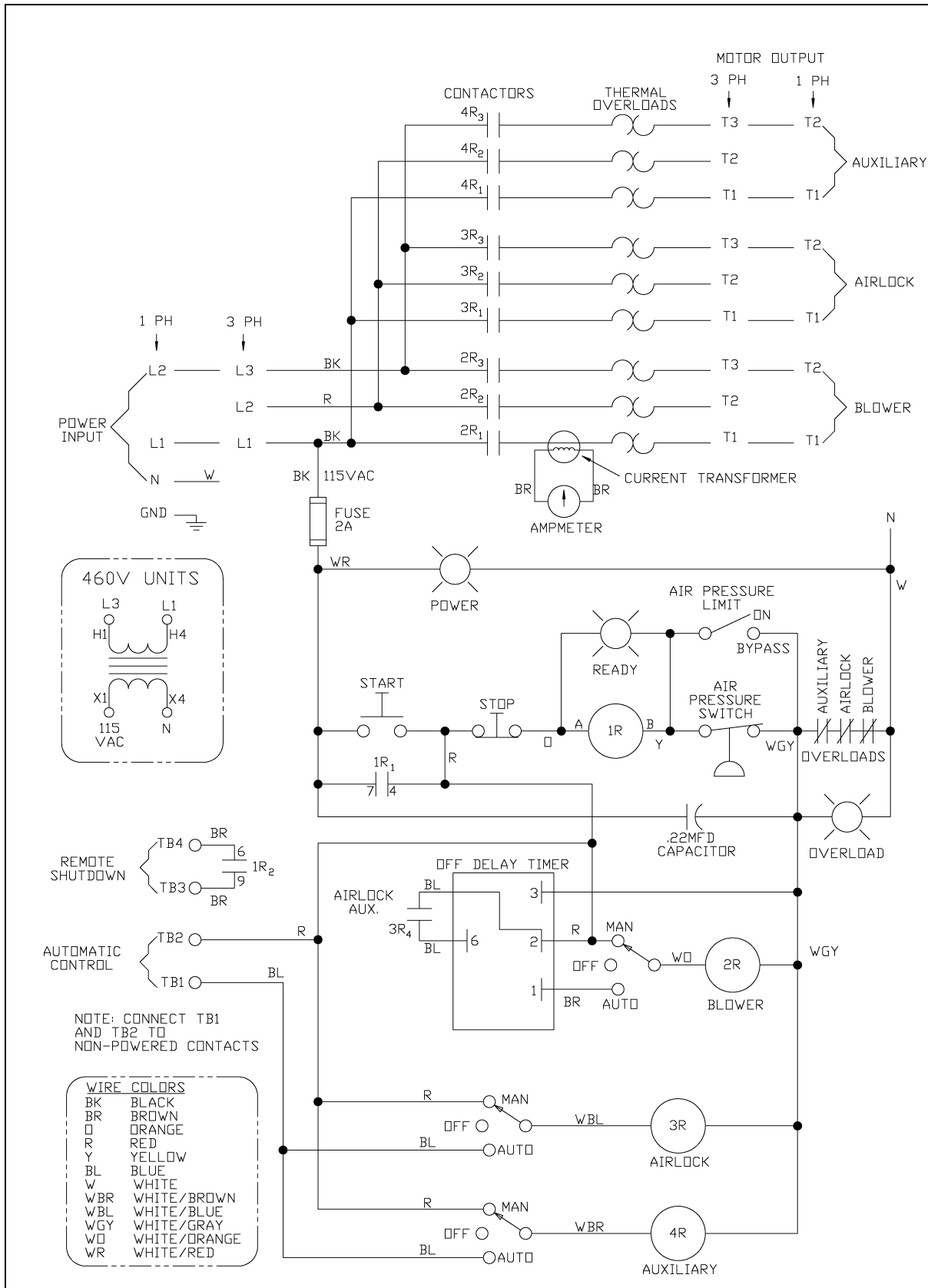

7. CONTROL BOX OPERATION

Control Box Operational Procedures

Automatic operation using the Automatic Controller Unit tied to terminals one (1) and two (2).

1. Place the Blower, Airlock and Auxiliary Control Switches in the “OFF” position.
2. Place the Air Pressure Limit Control Switch in the “ON” position (unit will stop when the air pressure reaches 10 PSI).
3. Turn on the power to the Air Systems Control Box. The power light should come on.
4. Push the Start button; the Control Circuit Ready Light should come on.
5. Place the Blower, Airlock and Auxiliary Switch in the “AUTO” position.
6. The complete air system will now run when the Automatic Controller completes the circuit between terminals one (1) and two (2). When this circuit is broken, the airlock and auxiliary equipment will stop immediately, but the blower will continue to run for an additional 15 seconds to clear the tubing in the system.
7. The airlock, auxiliary equipment, and blower will run when the control switches are placed in the “MANUAL” mode. The airlock, auxiliary equipment and blower will stop immediately when switched “OFF”.
8. Pushing the Stop button will immediately stop all air system functions as well as any equipment tied to terminals three (3) and four (4).

Operation of the air system WITHOUT an Automatic Controller tied to terminals one (1) and two (2).

1. Place the Blower, Airlock and Auxiliary Control Switches in the “OFF” position.
2. Place the Air Pressure Limit Control Switch in the “ON” position (unit will stop when the air pressure reaches 10 PSI).
3. Turn on the power to the Air System Control Box; the power light should come on.
4. Push the Start button. The Control Circuit Ready Light should come on.
5. The blower, airlock and auxiliary equipment can now be run by placing them in the “MANUAL” position. The airlock, auxiliary equipment and blower will stop immediately when switched off.
6. Pushing the stop button will immediately stop all air system functions as well as any remote equipment tied to terminals three (3) and four (4).

7. CONTROL BOX OPERATION

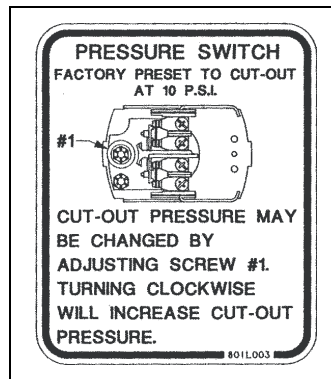

Figure 7A

Air System Operation Guidelines

1. Be aware of the quality of grain that is entering and leaving the air system. Grain damage can occur with any pneumatic system unless care is taken to adjust the velocity of the grain. This can be done by opening or closing the outlet gate valve on the blower outlet of the air system. Opening the valve will let air out of the tubing system which will slow the velocity of the air and grain in the tubing system. A recommended procedure is to open the valve slowly until the line pressure begins to surge and then to close it by 1/2 turn. This will provide the slowest possible grain velocity for any tubing system. This procedure for adjusting the air velocity should be repeated for each different tubing layout and capacity change.
2. If the tubing system should become plugged, place the air pressure limit switch to the “OFF” position, switch the airlock and auxiliary equipment to “OFF” and the blower to “MANUAL”. Note the opening of the outlet gate valve, then open it completely so all the air is exhausted when the blower is started.

⚠ CAUTION ⚠

Do not stand next to the exhausted air.

Push the start button and the blower will start. Slowly close the outlet gate valve until the grain starts moving and clears the tube. Adjust the valve as explained in [Step 1](#). It should be the same as noted before adjusting. Operate the airlock and auxiliary equipment in “MANUAL” until all grain is out of the system

3. The air pressure limit switch should always be in the “ON” position during routine operation to provide protection to the blower against overload conditions. The air pressure limit is set at the factory to shut down the system at 10 p.s.i. If adjustment is needed, rotate the adjusting screw counterclockwise to lower the pressure limit, or clockwise to increase the pressure limit. A one-half (1/2) turn of the screw will change the pressure limit one (1) p.s.i.

Note: If the pressure limit is set below five (5) p.s.i., the switch may not reset and allow the air transfer to run. (See [Figure 7A](#)).

7. CONTROL BOX OPERATION

4. The air filter element should be inspected daily and cleaned when required. Both the poly-foam pre-filter and the filter element can be cleaned by blowing air through them or washing them with mild detergent and water. A restricted air filter will cause a system to become plugged. It should always be inspected whenever plugging occurs.
5. The airlock is provided with a housing that incorporates grain shear protection to prevent grain damage.

6. GUIDELINES FOR OPERATION OF AIR SYSTEMS

- a. Grain in a pneumatic air system running at full capacity will move at about 60% of the air speed. A system operating at low capacities will move grain at 80-90% of the air speed.
- b. Decreasing the amount of air in the system (opening the hand gate valve) will cause the grain to move slower and also cause the air pressure to rise. (Essentially, the grain is causing the air to “pile up”).
- c. Increasing the air in a system (closing the gate valve) will increase the grain velocity and lower the pressure.

7. RECOMMENDATIONS FOR OFF-SEASON STORAGE

The blower and airlock have precision machined components and must be protected to prevent corrosion and rust from forming on the blower lobes and airlock vanes. These parts should be coated with motor oil after each drying season. (Spray lubricants such as WD-40 do not usually provide adequate protection.)

Both the airlock and blower assemblies should be carefully protected from the weather and the piping system disconnected from the blower and airlock. Remove the transition connection to the airlock inlet and re-install the weather cover shipped with the airlock. This is important to prevent condensation from collecting in the airlock and blower.

8. HOOK-UP DIAGRAMS

WIRING FOR A SURGE TANK HOOKED TO A TRANS-FER

The Air System will start when both P1 and P2 are closed. As it empties, P1 will open but will not stop the unit due to 4R4 being closed. When P2 opens, the unit will stop.

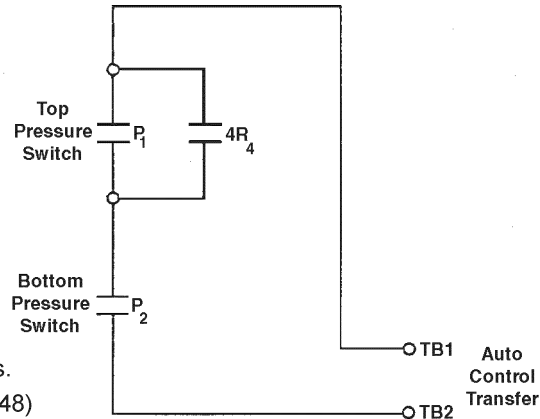

P1 and P2 are Pressure Switches.
4R4 is an Auxiliary Switch (2EL0648)
attached to the Top Contactor 4R4.

HOW TO HOOK UP AIR SYSTEM TO REMOTE EQUIPMENT

Remote Equipment
Control Circuit

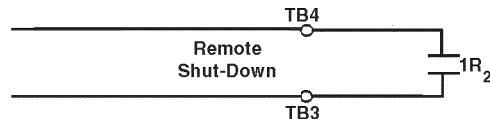

Any contact that
closes upon start
and opens on stop.
(Note: This contact
must not have any
external AC Power)

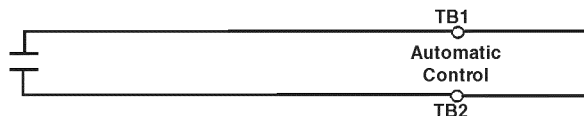

With the above hook up, the Air System must be started before the remote equipment. If the Air System is manually turned off or turned off from high pressure or an overload, the remote equipment will also turn off.

TB3 and TB4 will have a closed contact (1R2) as long as the air system has the "ready" indicator (located in the control box) on. The automatic control TB1 and TB2 requires a closed contact across them to start the air system unit.

1. 6" (2100) with 1760RPM Motors Blower Parts
2. Blower Filter Parts
3. 6" Airlock Parts
4. Airlock Inlet Transition Assembly
5. Inlet Tube Kit Parts
6. Panel Module Assembly - Digital
7. Panel Module Assembly - Analog
8. Switch Panel Assembly
9. Standard Control Panel - 230V 40-50 HP
10. Control Panel Assembly - 230V 60-75 HP
11. Blower Panel Assembly - 230V 60-75 HP
12. Standard Control Panel - 460V 40-60 HP
13. CSA Control Panel Assembly - 460V 40-60 HP
14. Control Panel Assembly - 460V 75HP

9. PARTS

6" (2100) with 1760RPM Motors Blower Parts

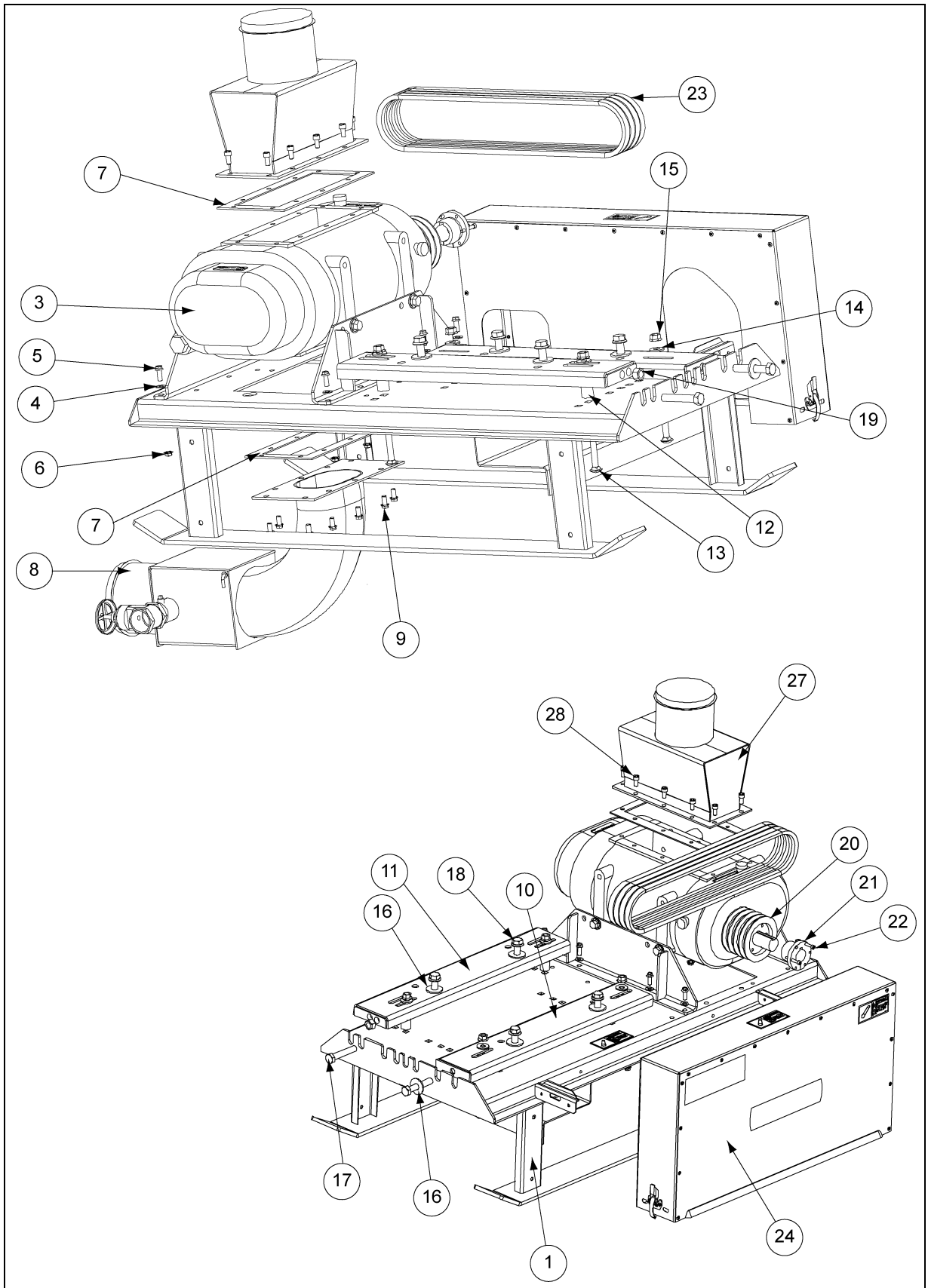

6" Blower Parts with 1760RPM Motors

REF #	PART #	DESCRIPTION	QTY	QTY	QTY
	AS-0126	AIR SYSTEM - 6 IN BLOWER 40HP	X	-	-
	AS-0129	AIR SYSTEM - 6 IN BLOWER 50 - 60HP	-	X	-
	AS-0130	AIR SYSTEM - 6 IN BLOWER 75HP	-	-	X
1	8011250-RD	BLOWER BASE WELD - 6 IN DMC	AR	AR	AR
	8011250-OR	BLOWER BASE WELD - 6 IN FFI	AR	AR	AR
2	DC-994	DECAL - DANGER SHEAR POINT	1	1	1
3	AS-0118-D	BLOWER SUB - ASY 6 IN HICAP DMC	AR	AR	AR
	AS-0118-F	BLOWER SUB - ASY 6 IN HICAP FFI	AR	AR	AR
4	S-248	WASHER FLAT 3/8 USS ZN YDP GR2	8	8	8
5	S-9065	BOLT FLANGE 3/8-16 x 1 ZN GR5	8	8	8
6	S-968	NUT FLANGEWZ 3/8-16 ZN GR5	8	8	8
7	804A114	GASKET - 6" ROOTS - FLO	2	2	2
8	8041165	BLOWER OUTLET ELBOW ASY - 6 IN	1	1	1
9	S-9067	BOLT FLNGS 3/8-16 x 3/4 ZN GR5	10	10	10
10	804A066-GY	MOTOR ADJUST RAIL WELD-6 IN RH	1	1	1
11	804A068-GY	MOTOR ADJUST RAIL WELD-6 IN LH	1	1	1
12	801A116-GY	MOTOR MOUNT SPACER - GREY	4	4	4
13	2FH0677	BOLT CARG 1/2-13 x 2-1/2 GR5 PLT	4	4	4
14	S-2120	WASHER FLAT 1/2 SAE	4	4	4
15	S-8506	NUT FLANGEWZ 1/2-13 ZN	4	4	4
16	S-858	WASHER FLAT 5/8 USS ZN	5	5	5
17	2FH1043	BOLT 5/8-11 x 3-1/2 HHTB GR2 PLT	2	2	2
18	S-9264	BOLT FLNGS 5/8-11 x 2 ZN GR5	4	4	4
19	S-4110	NUT HEX 5/8-11 ZN/YEL DI GR5	1	1	1
20	PT0736	PULLEY - 4.95" OD x SD BUSHING 4AB	1	-	-
	PT0668	PULLEY - 4.95" OD x SD BUSHING 5AB	-	1	-
	PT0669	PULLEY - 4.95" OD x SD BUSHING 6AB	-	-	1
21	GC06682	BUSHING - (QD STYLE)1-7/16 BORE	1	1	1
22	2FH5055	SCREW 1/4-20 x 1-3/4 GR8 SHCS	2	2	2
23	MHC00028	V-BELT B x 60	4	5	6
24	8011256	SHIELD ASY - BLOWER STD	1	1	1
25	804L001	DECAL - TRANSFER 2100	AR	AR	AR
26	DC-1330	LOGO DECAL - DMC 2-7/8 x 9	AR	AR	AR
	420-1443-1	DECAL - FFI 14.5 x 12	AR	AR	AR
27	8041144-RD	BLOWER INLET WELD - 6 IN RED	AR	AR	AR
	8041144-OR	BLOWER INLET WELD - 6 IN ORG	AR	AR	AR
28	S-8898	SCREW MS 3/8-16 x 3/4 SHCS	10	10	10

MOTORS & DRIVE PARTS (NOT SHOWN)					
REF #	PART #	DESCRIPTION	QTY	QTY	QTY
	4000-3	MOTOR 40HP 3PH 1760RPM	X	-	-
	5000-3	MOTOR 50HP 3PH 1760RPM	-	X	-
	6000-3	MOTOR 60HP 3PH 1760RPM	-	X	-
	7500-3	MOTOR 75HP 3PH 1760RPM	-	-	X
	PT0737	SHEAVE 4GR B8.6 SK	X	-	-
	PT0784	BUSHING QD 2.1/8" BORE SK	X	-	-
	PT0671	PULLEY 8.95"OD x SF BUSH-5AB	-	X	-
	GT3-0068	BUSHING QD SF 2-1/8 (USE WITH 50HP)	-	X	-
	PT0672	PULLEY 8.95"OD SF BUSH-6AB	-	-	X
	PT0786	BUSHING QD STYLE SF 2-3/8 (60 & 70HP)	-	X	X

9. PARTS

6" (2100) With 3500RPM Motors Blower Parts

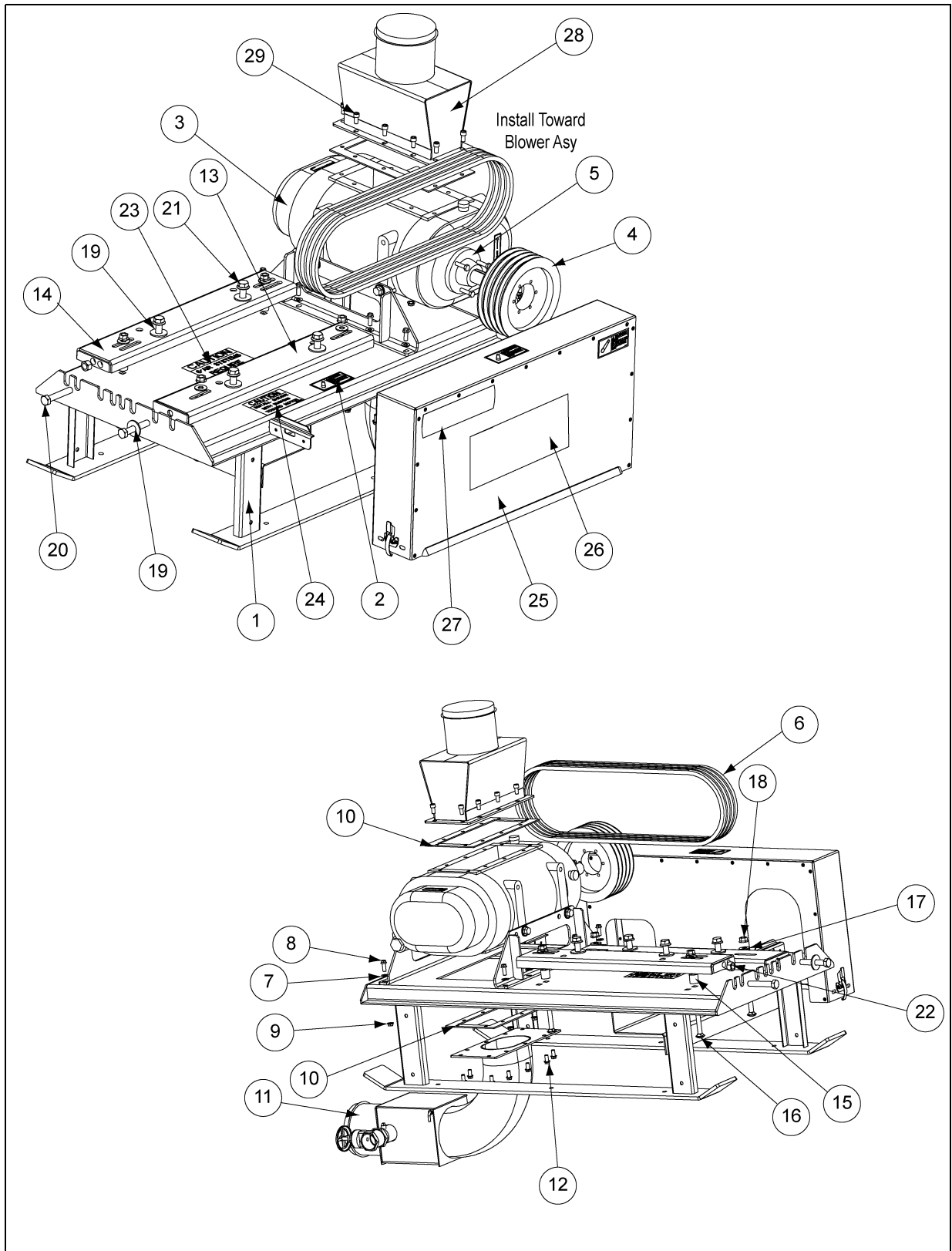

6" Blower Parts With 3500RPM Motors

REF #	PART #	DESCRIPTION	QTY	QTY	QTY
	AS-0126	AIR SYSTEM - 6 IN BLOWER 40HP	X	-	-
	AS-0129	AIR SYSTEM - 6 IN BLOWER 50-60HP	-	X	-
	AS-0130	AIR SYSTEM - 6 IN BLOWER 75HP	-	-	X
1	AS-0207-RD	BLOWER BASE WELD - 6 IN 3500RPM RED	1AR	1AR	1AR
	AS-0207-OR	BLOWER BASE WELD - 6 IN 3500RPM ORG	1AR	1AR	1AR
2	DC-994	DECAL - DANGER SHEAR POINT	1	1	1
3	AS-0118-D	BLOWER SUB - ASY 6IN HICAP DMC	1AR	1AR	1AR
	AS-0118-F	BLOWER SUB - ASY 6IN HICAP FFI	1AR	1AR	1AR
4	PT0737	SHEAVE 4GR B8.6 SK	1	-	-
	PT0671	SHEAVE 5GR B8.6 SF	-	1	-
	PT0672	SHEAVE 6GR B8.6 SF	-	-	1
5	GC06687	BUSHING SK x 1-7/16" BORE	1	-	-
	GC07551	BUSHING SF x 1-7/16" BORE	-	1	1
6	MHC00616	V-BELT B x 66	4	5	6
7	S-248	WASHER FLAT 3/8 USS ZN YDP GR2	8	8	8
8	S-9065	BOLT FLNGS 3/8-16 x 1 ZN GR5	8	8	8
9	S-968	NUT FLANGWZ 3/8-16 ZN GR5	8	8	8
10	804A114	GASKET - 6" ROOTS-FLO	2	2	2
11	8041165	BLOWER OUTLET ELB ASY - 6IN	1	1	1
12	S-9067	BOLT FLNGS 3/8-16 x 3/4 ZN GR5	10	10	10
13	804A066-GY	MOTOR ADJUST RAIL - 6IN RH GRAY	1	1	1
14	804A068-GY	MOTOR ADJUST RAIL - 6IN LH GRAY	1	1	1
15	801A116-GY	MOTOR MOUNT SPACER - GRAY	4	4	4
16	2FH0677	BOLT CARG 1/2-13 x 2-1/2 GR5 PLT	4	4	4
17	S-2120	WASHER FLAT 1/2 SAE	4	4	4
18	S-8506	NUT FLANGWZ 1/2-13 ZN	4	4	4
19	S-858	WASHER FLAT 5/8 USS ZN	5	5	5
20	2FH1043	BOLT 5/8-11 x 3-1/2 HHTB GR2 PLT	2	2	2
21	S-9264	BOLT FLNGS 5/8-11 x 2 ZN GR5	4	4	4
22	S-4110	NUT HEX 5/8-11 ZN/YEL DI GR5	1	1	1
23	DC-1867	CAUTION - REQUIRES 3500RPM MOTOR	1	1	1
24	DC-1869	CAUTION - INSTALL SHEAVE	1	1	1
25	AS-0251	BLOWER SHIELD-ASY 6" AIR SYS 3500RPM	1	1	1
26	4007001	LOGO DECAL - DMC 24 x 6-11/32	1AR	1AR	1AR
	420-1443-1	DECAL - FFI 14.5 x 12	1AR	1AR	1AR
27	804L001	DECAL - TRANSFER 2100	1AR	1AR	1AR
28	8041144-RD	BLOWER INLET WELD - 6 IN RED	1AR	1AR	1AR
	8041144-OR	BLOWER INLET WELD - 6 IN ORG	1AR	1AR	1AR
29	S-8898	SCREW MS 3/8-16 x 3/4 SHCS	10	10	10

MOTORS & DRIVE PARTS (NOT SHOWN)

REF #	PART #	DESCRIPTION	QTY	QTY	QTY
	CH-5582	MOTOR 40HP 3PH 3500RPM	X	-	-
	CH-5583	MOTOR 50HP 3PH 3500RPM	-	X	-
	6000-3-3500	MOTOR 60HP 3PH 3500RPM	-	X	-
	7500-3-3500	MOTOR 75HP 3PH 3500RPM	-	-	X
	PT0737	SHEAVE 4GR B8.6 SK	X	-	-
	CE-00617	BUSHING SK 1-7/8" BORE QD STYLE	X	-	-
	PT0671	PULLEY 8.95"OD x SF BUSH-5AB	-	X	-
	MHC01162	BUSHING SF 1-7/8" BORE QD STYLE	-	X	X
	PT0672	PULLEY 8.95"OD SF BUSH-6AB	-	-	X

9. PARTS

Blower Filter Parts

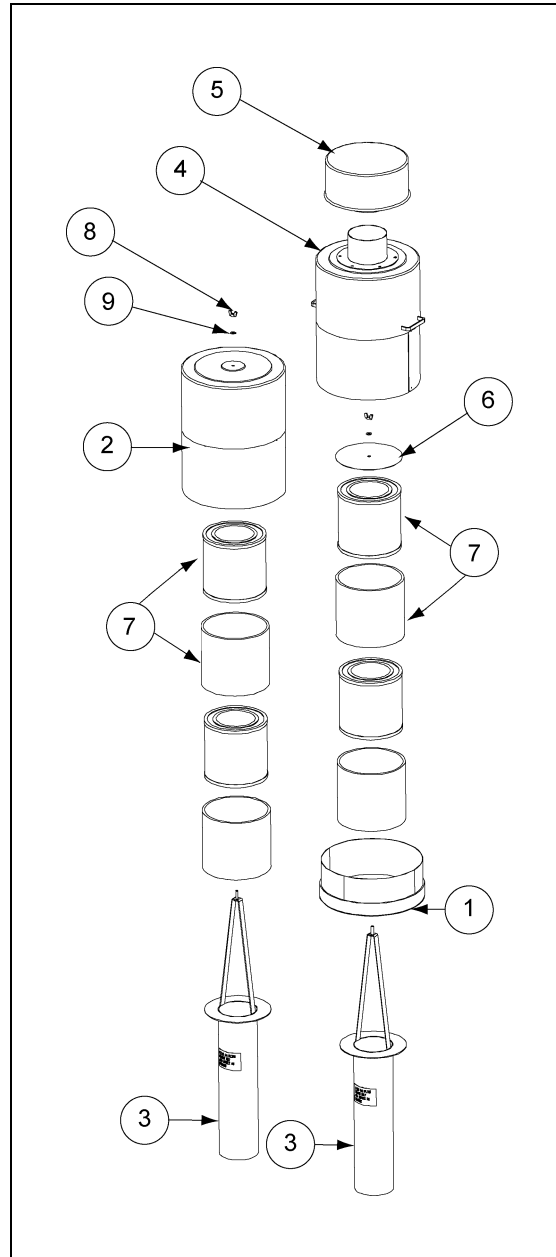

REF #	PART #	DESCRIPTION	QTY
1	8041190-GY	PRECLEANER BASE WELDMENT - 6IN PAINTED GRAY	1
2	804A086-RD	AIR FILTER CANISTER WELDMENT - 6IN PAINTED RED	1
3	804A110 -D	FILTER BASE ASSEMBLY - 6IN	1
4	8041187	PRECLEANER CANISTER ASSEMBLY - 6IN	1
5	MS5467	PRECLEANER - 6IN INLET CENTRI #EX-60 (500-950 CFM)	1
6	8021228	FILTER TOP PLATE - 4IN, 5IN, & 6IN PRECLEANER	1
7	801A152	FILTER ELEMENTS - INNER & OUTER	2
8	S-1451	WING NUT - 3/8"-16 UNC ZINC PLATED	1
9	S-248	FLAT WASHER - STANDARD 3/8" ZINC PLATED	1

NOTES

9. PARTS

6" Airlock Parts

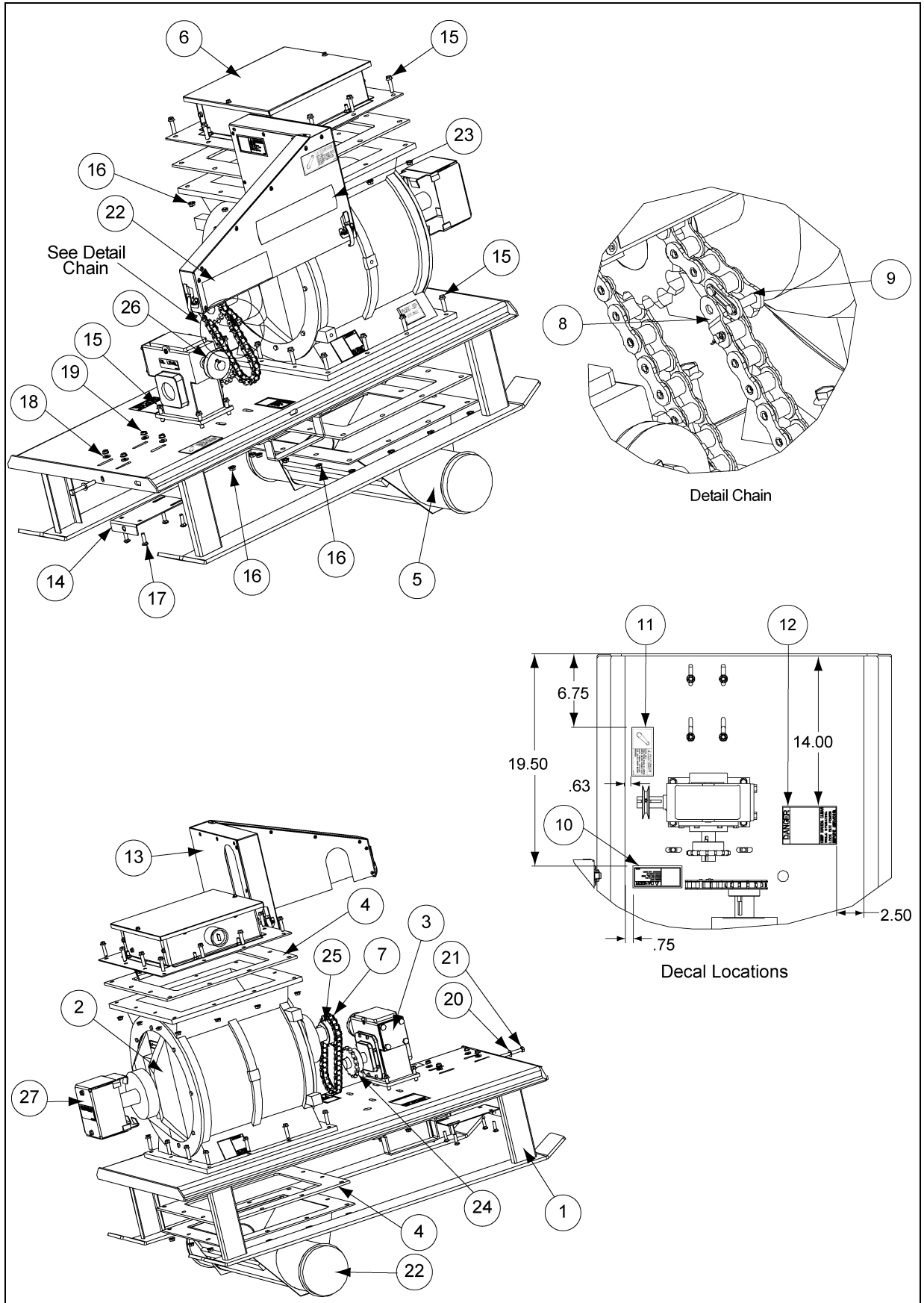

6" Airlock Parts

REF #	PART #	DESCRIPTION	QTY
1	8041150-GY	AIRLOCK BASE WELD - 6" GREY	1
2	AS-0119	AIRLOCK SUB - ASY- 6" SYSTEM GREY	1
3	AS-0114	AIR SYS - ALK GEARBOX ASY-RED	1
4	804A113	GASKET - 6IN AIRLOCK	2
5	8041210-GY	AIRLOCK HOPPER WELD - 6IN GREY	1
6	AS-0096	AIRLOCK INLET ASY - 6"	1
7	804A053	ROLLER CHAIN - 6" AIRLOCK	1
8	PT1054	LINK - OFFSET, #60 3/4PITCH	1
9	KD-PRC6001	LINK - CONNECTING, #60 3/4PITCH	1
10	DC-1382	DECAL - CHAIN DANGER 1.75" x 4"	1
11	DC-994	DECAL - DANGER SHEAR POINT	1
12	N10090	DECAL - CAUTION AIRLOCK	1
13	804A074	SHIELD ASY - 6IN AIRLOCK	1
14	8011342-GY	AIRLOCK MTR ADJUST PLATE GREY	1
15	S-9064	BOLT FLNG 3/8-16 x 1-1/2 ZN GR5	28
16	S-968	NUT FLANGEWZ 3/8-16 ZN GR5	28
17	S-8059	BOLT CARG 5/16-18 x 1 ZN GR2	4
18	S-845	WASHER FLAT 5/16 USS ZN YDP	4
19	S-3611	NUT FLANGEWZ 5/16-18 ZN YDP	4
20	S-248	WASHER FLAT 3/8 USS ZN YDP GR2	1
21	S-8132	BOLT HHTB 3/8- 16 x 3 ZN GR2	1
22	DC-1330	LOGO DECAL - DMC 2-7/8 x 9	AR
23	804L001	DECAL - TRANSFER 2100	AR
	420-1507-3	LOGO DECAL - FFI	AR
24	PT1106	SPROCKET - HUB TYPE 1-1/4" ID	1
25	PT1107	SPROCKET - HUB TYPE 1-3/4" ID	1
26	PT0622	PULLEY - FLAT 3.00 OD x 1.00 ID 1A	1
27	AS-0117	AIRLOCK SHAFT GUARD ASSEMBLY	1

MOTORS & DRIVE PARTS (NOT SHOWN)

REF #	PART #	DESCRIPTION	QTY
	100-1	MOTOR 1HP 1PH 56 TEFC 5/8 SHAFT	X
	002-1087-2	MOTOR 1HP 3PH 56 TEFC 5/8 SHAFT	X
	PT0483	V-BELT/ A31	X
	PT0618	PULLEY 3.25"OD x .62"ID - 1A	X

9. PARTS

Airlock Inlet Transition Assembly

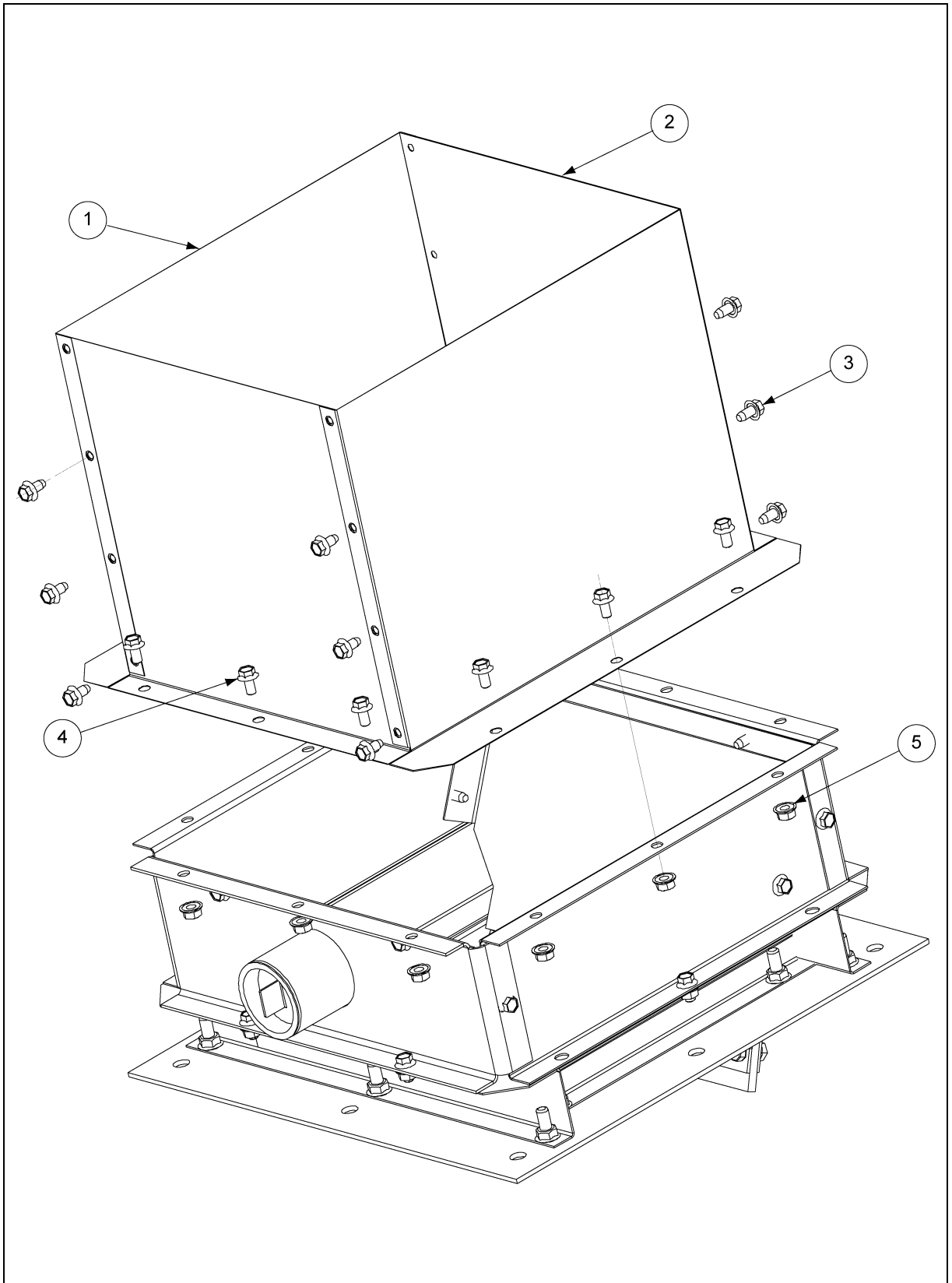

Airlock Inlet Transition Assembly

REF #	PART #	DESCRIPTION	QTY
1	AS-0077	AIRLOCK INLET TRANS - RH & LH	2
2	AS-0078	AIRLOCK TRANS - FRONT & BACK	2
3	S-9028	SCREW SMSAB 1/4-14 x 1/2 HWH ZN	12
4	S-8857	BOLT FLNGS 1/4-20 x 1/2 ZN GR5	10
5	S-7215	NUT FLANGEWZ 1/4-20 ZINC	10

Installation Of Airlock Transition To Dryer Discharge

1. Remove the weather cover from the airlock inlet assembly.
2. Assemble (2) AS-0077 (item 1) and (2) AS-0078 together with S-9028 (Item 3) self-tapper screws as shown in the diagram.
3. Determine what direction the airlock grain line is to run. orient the transition assembly to correspond with the line direction. Attach the transition assembly to the airlock inlet using S-8857 (Item 4) and s-7215(Item 5).
4. Trim the top of the transition assembly to match the height of the dryer discharge.

9. PARTS

Inlet Tube Kit Parts

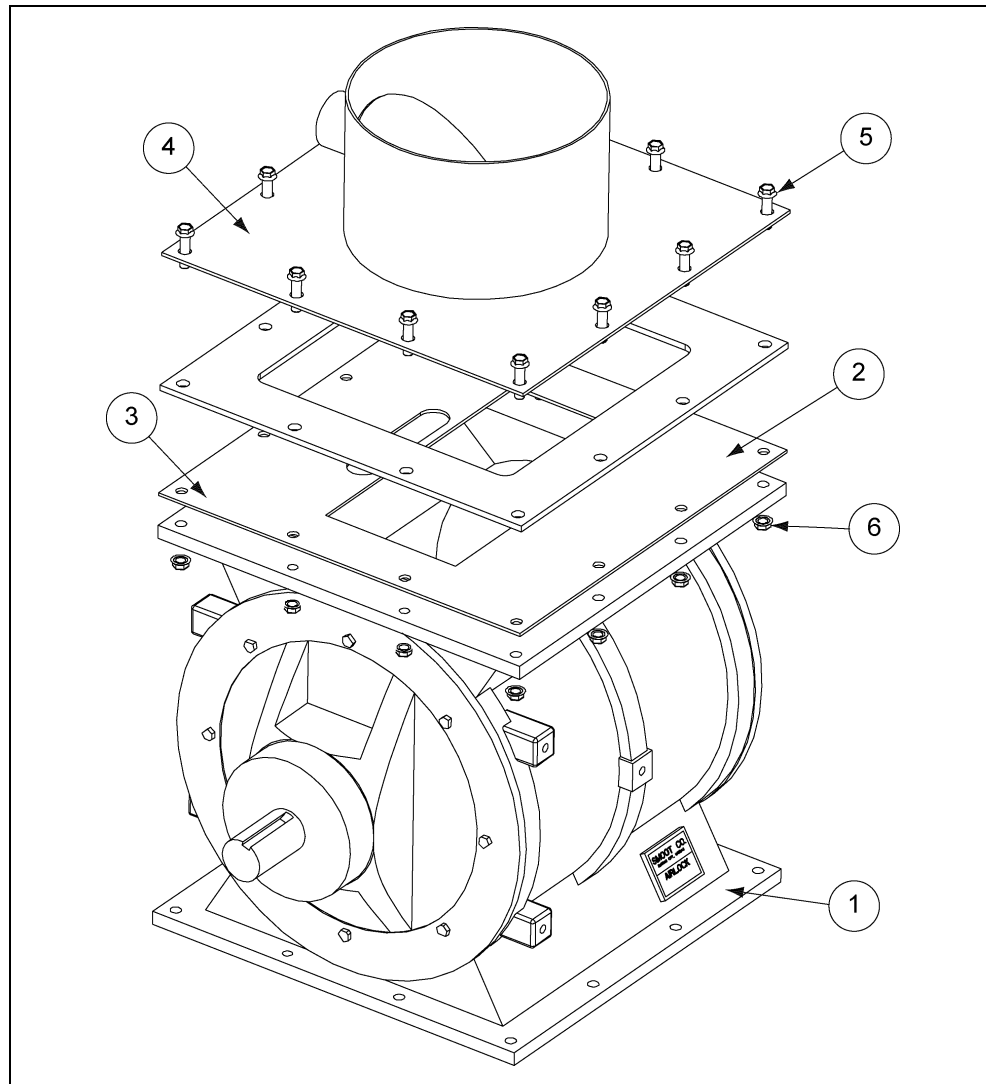

REF #	PART #	DESCRIPTION	QTY	QTY
	AS-0122	TUBE INLET KIT - 6IN ALK 40HP	X	
	AS-0123	TUBE INLET KIT - 6IN ALK 50-75HP		X
1	AS-0119	AIRLOCK SUB - ASY 6IN SYS GRAY	REF	REF
2	8041176	SHEAR BRACKET & WIPER ASY	1	-
	8041177	SHEAR BRACKET & WIPER ASY	-	1
3	804A113	GASKET - 6IN AIRLOCK	1	1
4	804A044	INTAKE SPOUT - 6" AIRLOCK 10IN	1	-
	804A104	INTAKE SPOUT - 6" AIRLOCK 12IN	-	1
5	S-9064	BOLT FLNG 3/8-16 x 1-1/2 ZN	12	12
6	S-968	NUT FLANGEWZ 3/8-16 ZN GR5	12	12

Panel Module Assembly - Digital

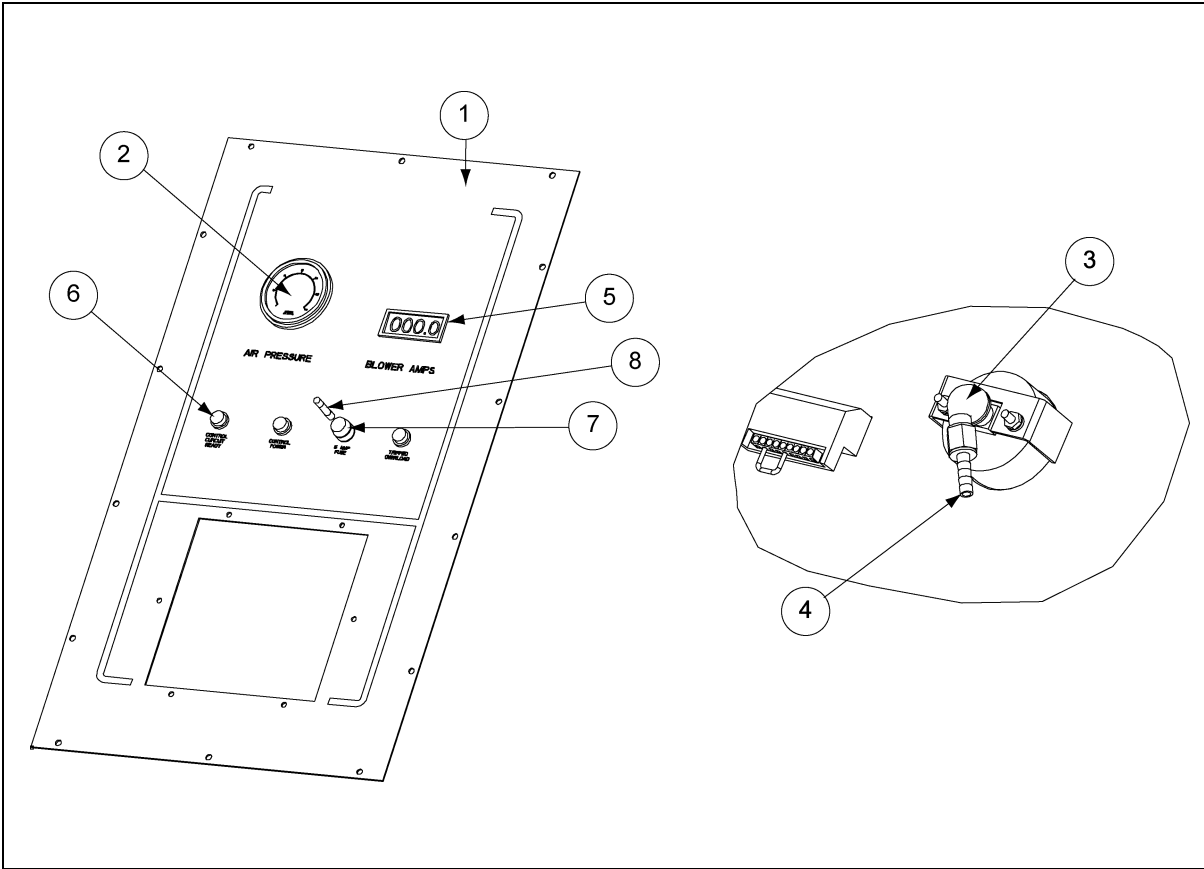

REF #	PART #	DESCRIPTION	QTY
1	8015075D-DC	DECAL - TRANSFER PANEL W/DIGIAMP	1AR
1	8015121F-DC	DECAL - CONVEY AIR PANEL W/DIGIAMP	1AR
2	PT1125	GAUGE- (PRESSURE) 2-1/2" 15PSI	1
3	4FH0452	FIT-ELBOW,STREET(90) 1/4 NPT	1
4	4FH1122	FIT-HOSE BARB, 1/4X1/4 BRASS	1
5	AS-0211A	DIGITAL AMP METER ASY W/JUMPER	1
6	TFH-2021	LIGHT RED NEON NO LEADS 125VAC	3
7	1EL0826	FUSEHOLDER-PANMNT(CSA)30A 250V	1
8	1EL0754	FUSE- AGC5 250V 5AMP	1

9. PARTS

Panel Module Assembly - Analog

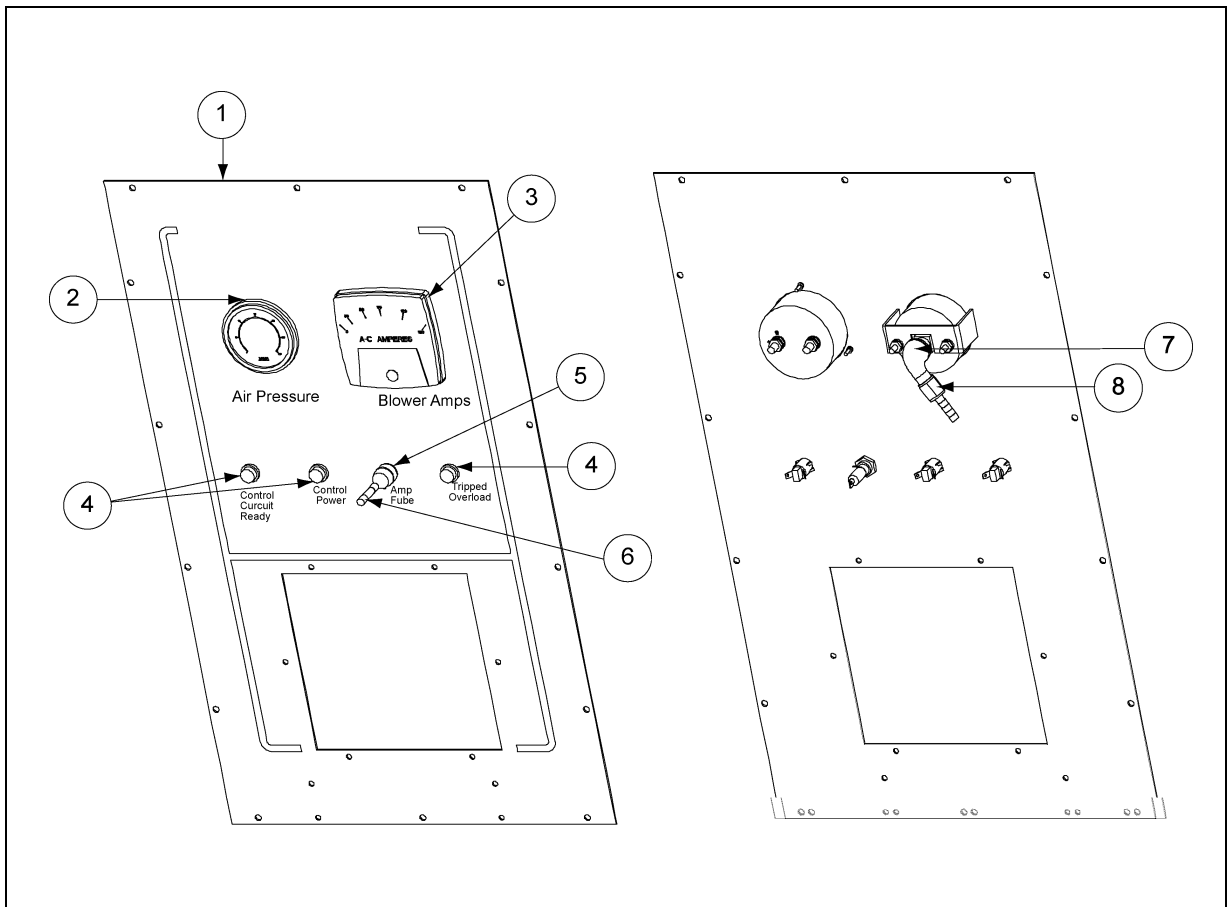

REF #	PART #	DESCRIPTION	40/50 HP QTY	230V 60/75 QTY
1	8015075D-DC	DECAL - TRANSFER PANEL W/DIGIAMP	1	1
1	8015121D-DC	DECAL - CONVEY AIR PANEL W/DIGIAMP	1	1
2	PT1125	GAUGE- (PRESSURE) 2-1/2" 15PSI	1	1
3	2EL0290	AMP METER PANEL 0-150 AMP	1	-
3	2EL0687	AMP METER PANEL 0-200 AMP	-	1
4	TFH-2021	LIGHT RED NEON SPADE TERM 125VAC	3	3
5	1EL0826	FUSEHOLDER-PANEL MOUNT 30A 250V	1	1
6	1EL0754	FUSE- AGC5 250V 5AMP	1	1
7	4FH0452	FITTING-ELBOW - STREET(90) 1/4 NPT	1	1
8	4FH1122	FITTING-HOSE BARB 1/4 x 1/4 BRASS	1	1

Switch Panel Assembly

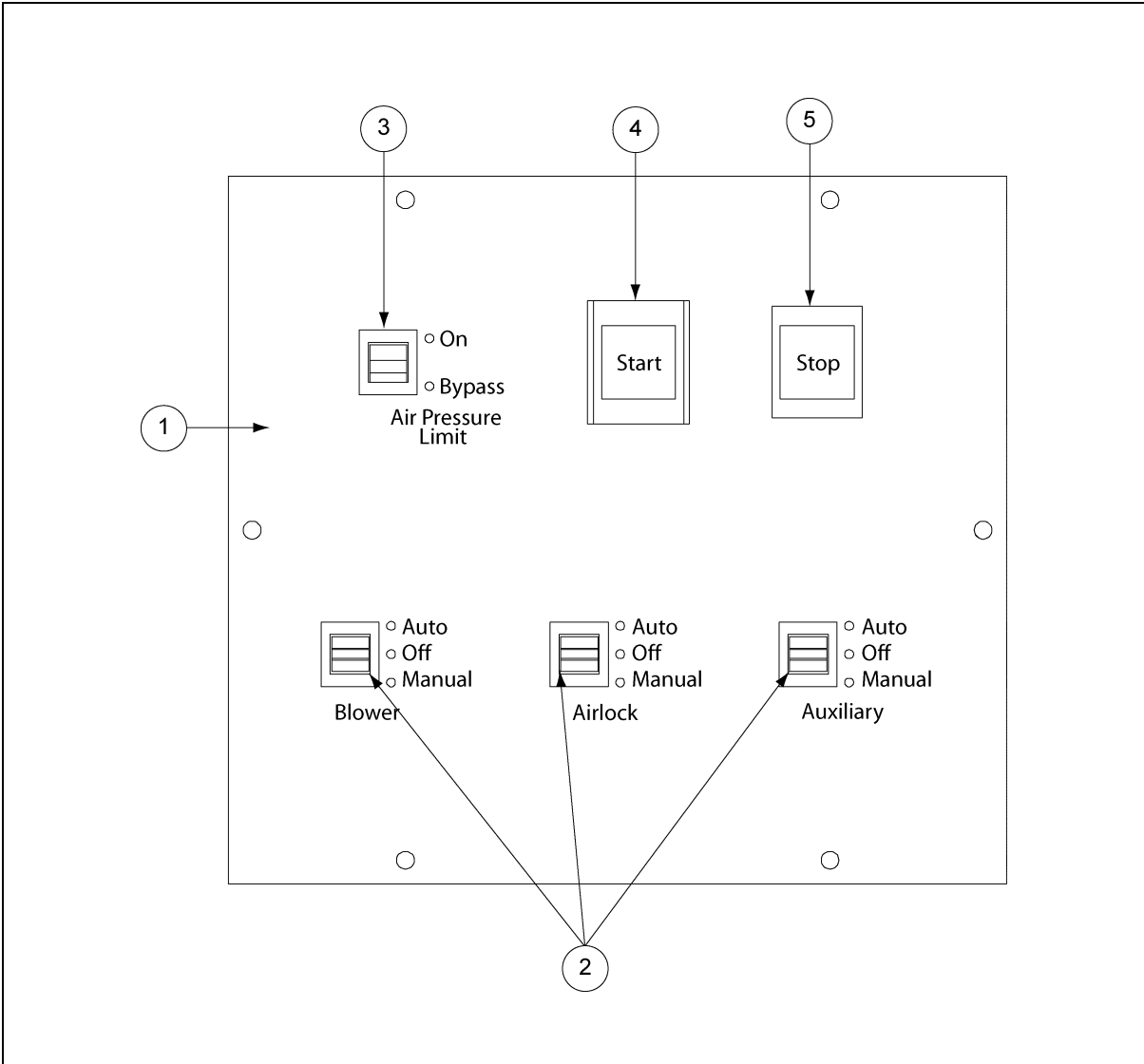

REF #	PART #	DESCRIPTION	QTY
1	8015078-DC	DECAL - SWITCH PANEL STD AIR SYSTEMS	1
2	2EL0668	LEVER SWITCH - SPDT (ON-OFF-ON)	3
3	2EL0659	LEVER SWITCH - SPDT (ON-NONE-ON)	1
4	2EL0618	PUSHBUTTON SWITCH - SPST (START)	1
5	2EL0619	PUSHBUTTON SWITCH - SPST (STOP)	1

9. PARTS

Standard Control Panel - 230V 40-50 HP

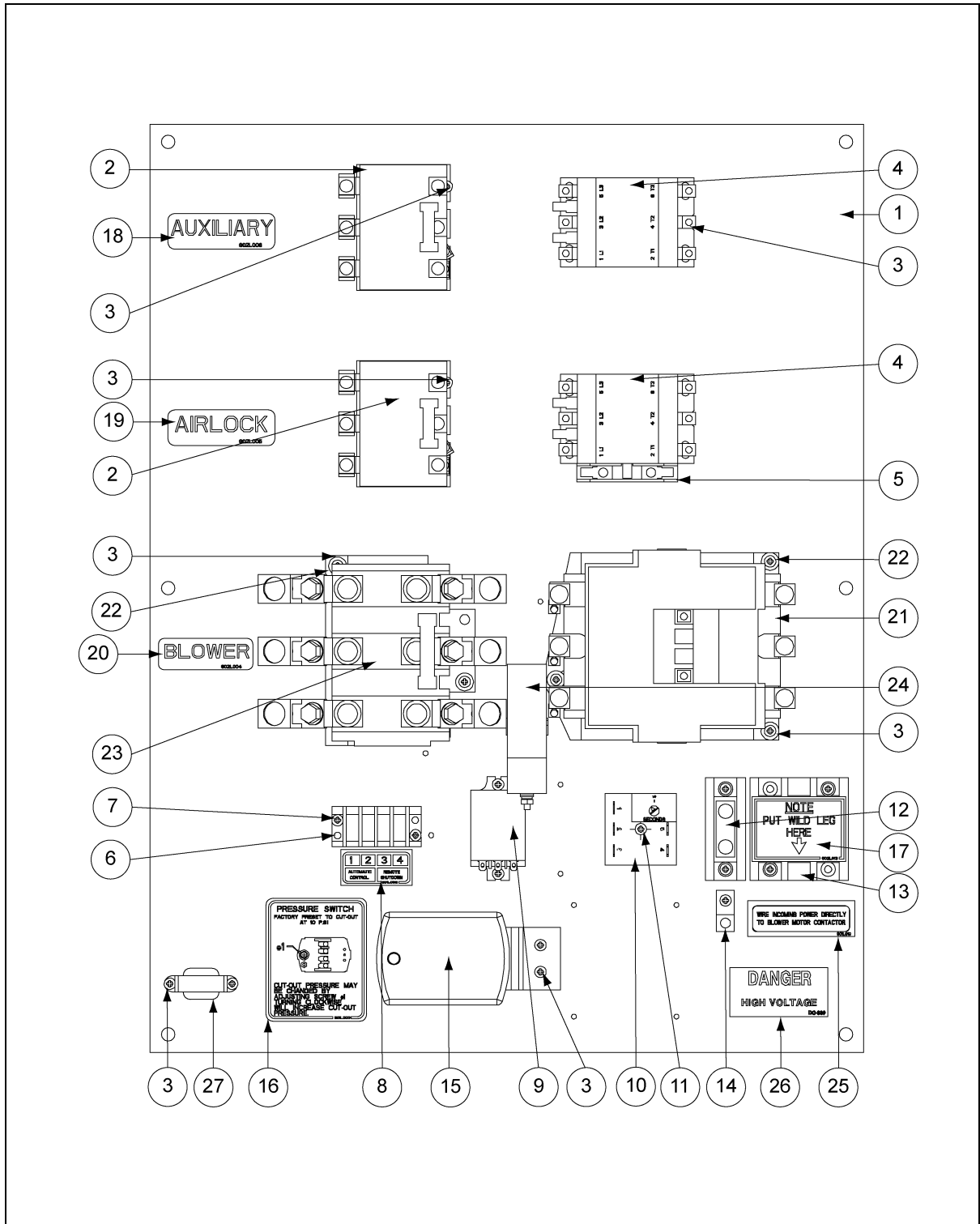

Standard Control Panel - 230V 40-50 HP

REF #	PART #	DESCRIPTION	ANALOG QTY	DIGITAL QTY
1	8015079	AIR SYS - CONTROL PANEL (SNGL)	1	1
2	2EL0281	RELAY THRML OVELOAD 26AMP	2	2
3	S-1158	SCREW TCSF #8 - 32 x 1/2 PHP ZN	22	24
4	2EL0243	40A CONTACTOR - MAGNETIC (CSA)	2	2
5	2EL0648	CONTACT - AUXILIARY MOTOR CONTACTOR	1	1
6	1773	TERMINAL BLOCK 4 POLE 2 ROW	1	1
7	S-6557	SCREW TCSF #8 - 32 x 3/4 PHP ZN	2	2
8	801L006	DECAL - TERMINAL STRIP	1	1
9	2EL0273	RELAY - 3PDT 5A 120V DELTRO	1	1
10	801E047	TIMER - OFF DELAY, 15 SEC ASY	1	1
11	S-7124	SCREW TCSF #8 - 32 x 1 PHP ZN	1	1
12	1EL0909	PWR DIST. BLK 175A 600V 1P	1	1
13	C-8018	TERMINAL BLOCK 185A 3POLE 1:4	1	1
14	E160-1137	LUG GROUND - #TA-2 (CSA)	1	1
15	801E018	HIGH PRESSURE SWITCH ASY	1	1
16	801L003	DECAL - PRESSURE SWITCH	1	1
17	602L013	DECAL - WILD LEG	1	1
18	802L006	DECAL - AUXILIARY	1	1
19	802L005	DECAL - AIRLOCK	1	1
20	802L004	DECAL - BLOWER	1	1
21	2EL0249	CONTACTOR - 120AMP 120V COIL	1-40HP	1-40HP
21	056-2275-8	CONTACTOR - 150AMP 120V COIL IEC	1-50HP	1-50HP
22	S-3674	WASHER FLAT #10 SAE ZN	5	5
23	2EL0271	RELAY - OVERLOAD SIZE 4 133AMP	1	1
24	2EL0307	TRANSFORMER - CURRENT 150:5RATIO	1	-
24	2EL0368	TRANSFORMER - CURRENT 200:5RATIO	-	1
25	801L019	DECAL - WIRE INCOMING PWR	1	1
26	DC-889	DECAL - DANGER HIGH VOLTAGE ALL PF	1	1
27	AS-0211T	5AMP LIMIT TRANSFORMER-DIGITAL AMP	-	1

9. PARTS

Control Panel Assembly - 230V 60-75 HP

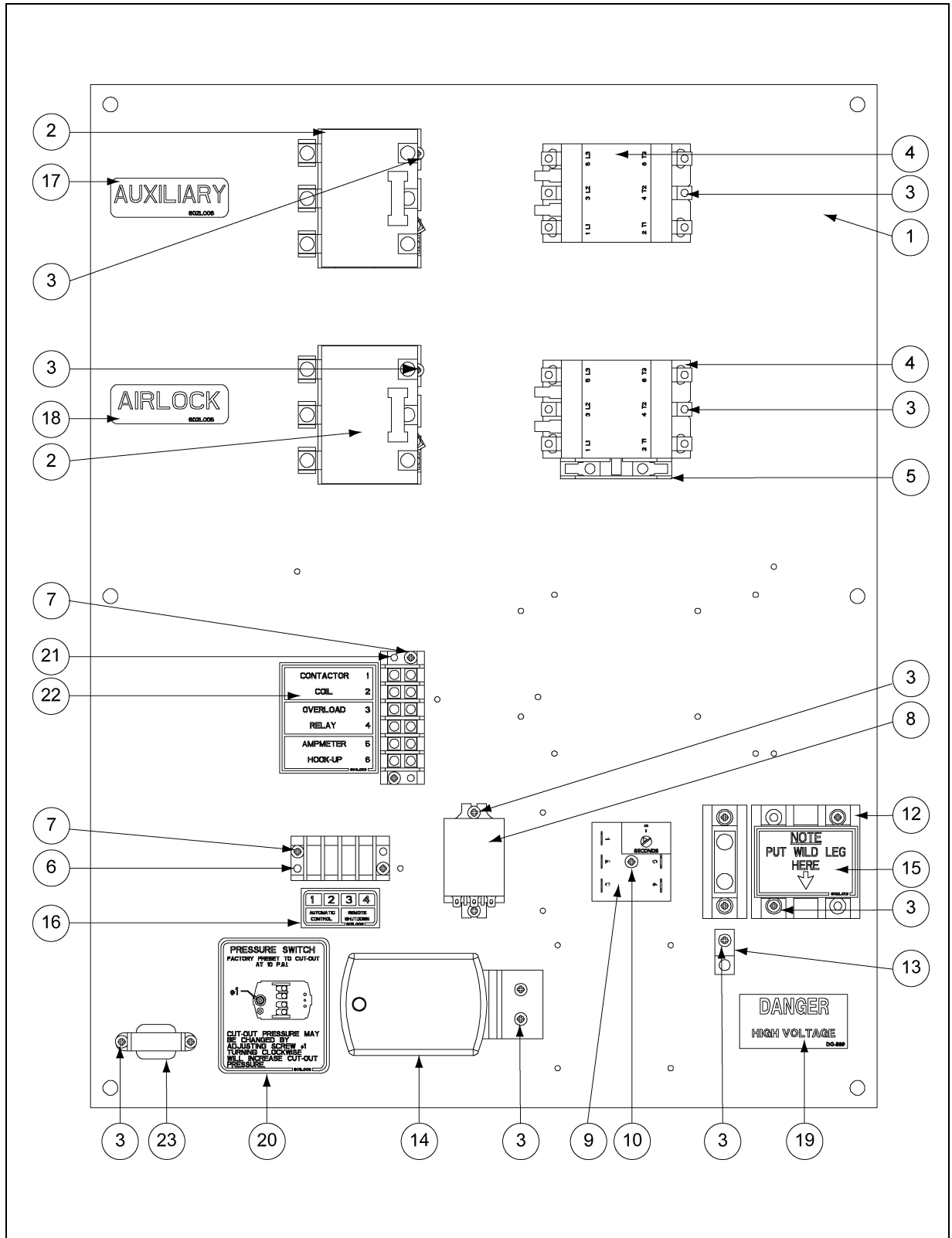

Control Panel Assembly - 230V 60-75 HP

REF #	PART #	DESCRIPTION	ANALOG QTY	DIGITAL QTY
1	8015079	AIR SYS - CONTROL PANEL (SNGL)	1	1
2	2EL0281	RELAY THRML OVELOAD 26AMP	2	2
3	S-1158	SCREW TCSF #8 - 32 x 1/2 PHP ZN	17	19
4	2EL0243	40A CONTACTOR - MAGNETIC (CSA)	2	2
5	2EL0648	CONTACT - AUXILIARY MOTOR CONTACTOR	1	1
6	1773	TERMINAL BLOCK 4 POLE 2 ROW	1	1
7	S-6557	SCREW TCSF #8 - 32 x 3/4 PHP ZN	4	4
8	2EL0273	RELAY - 3PDT 5A 120V DELTRO	1	1
9	801E047	TIMER - OFF DELAY, 15 SEC ASY	1	1
10	S-7124	SCREW TCSF #8 - 32 x 1 PHP ZN	1	1
11	1EL0909	PWR DIST. BLK 175A 600V 1P	1	1
12	C-8018	TERMINAL BLOCK 185A 3POLE 1:4	1	1
13	E160-1137	LUG GROUND, #TA-2 (CSA)	1	1
14	801E018	HIGH PRESSURE SWITCH ASY	1	1
15	602L013	DECAL - WILD LEG	1	1
16	801L006	DECAL - TERMINAL STRIP	1	1
17	802L006	DECAL - AUXILIARY	1	1
18	802L005	DECAL - AIRLOCK	1	1
19	DC-889	DECAL, DANGER HIGH VOLTAGE ALL PF	1	1
20	801L003	DECAL - PRESSURE SWITCH	1	1
21	1EL0877	TERM BLK 6P 30A 300V (CSA)	1	1
22	804L003	DECAL - TERMINAL BLOCK 6 POS	1	1
23	AS-0211T	5AMP LIMIT TRANSFORMER - DIGITAL AMP	-	1

9. PARTS

Blower Panel Assembly - 230V 60-75 HP

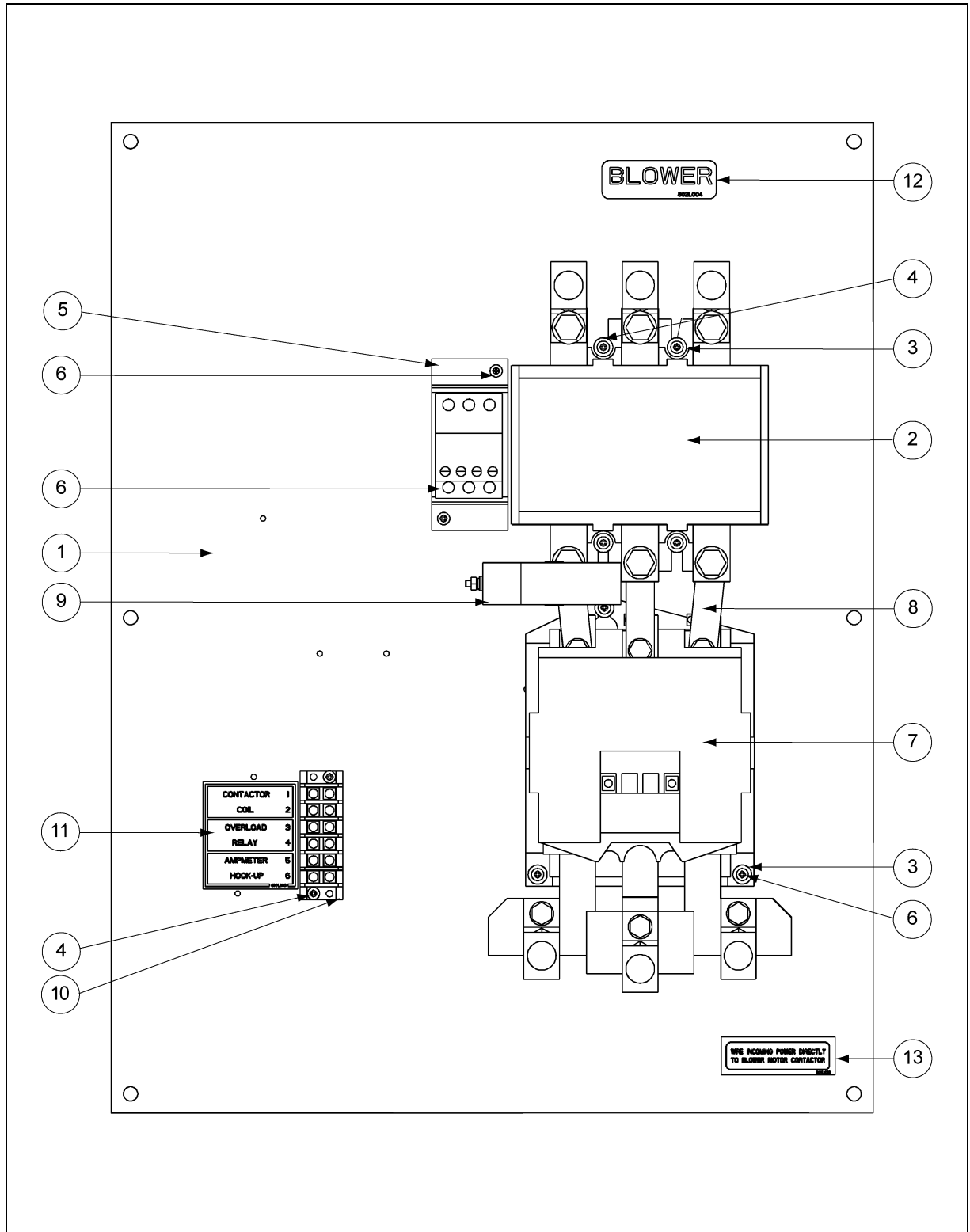

Blower Panel Assembly - 230V 60-75 HP

REF #	PART #	DESCRIPTION	QTY
1	8015089	AIR SYS - CONTROL PANEL 60 - 75HP	1
2	2EL0284	RELAY - IEC STYLE OVERLOAD 160 - 250A	1
3	S-3674	WASHER FLAT #10 SAE ZN	7
4	S-6557	SCREW TCSF #8 - 32 x 3/4 PHP ZN	6
5	801E066	BRACKET - ADJ. OVERLOAD	1
6	S-1158	SCREW TCSF #8 - 32 x 1/2 PHP ZN	7
7	2EL0258	CONTACTOR - MAGNETIC 230A	1
8	801E065	JUMPER BAR - MOTOR STARTER	3
9	2EL0368	TRANSFORMER - CURRENT 200:5RATIO	1
10	1EL0877	TERM BLK 6P 30A 300V (CSA)	1
11	804L003	DECAL - TERMINAL BLOCK 6 POS	1
12	802L004	DECAL - BLOWER	1
13	801L019	DECAL - WIRE INCOMING POWER	1

9. PARTS

Standard Control Panel - 460V 40-60 HP

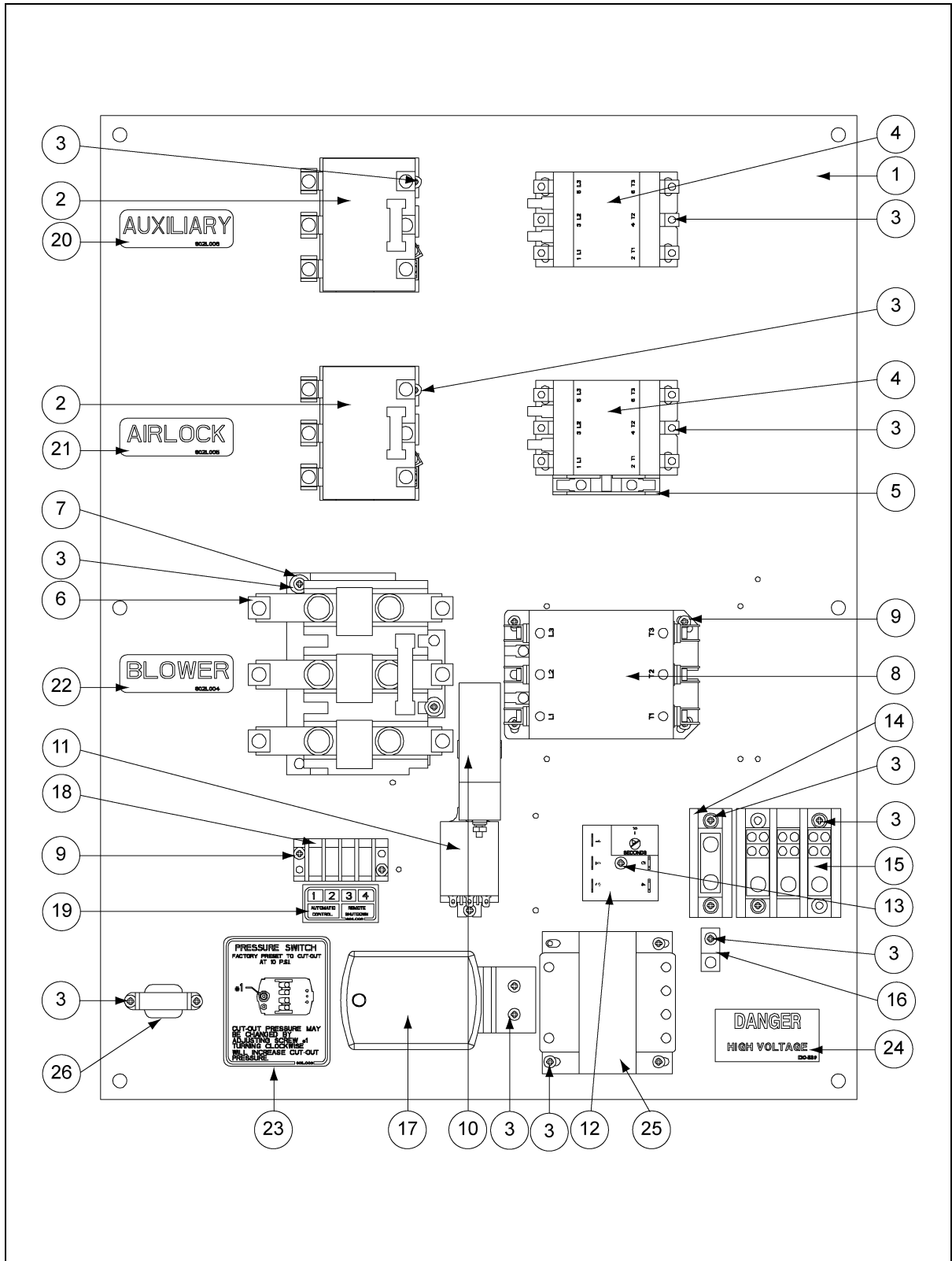

Standard Control Panel - 460V 40-60 HP

REF #	PART #	DESCRIPTION	ANALOG QTY	DIGITAL QTY
1	8015079	AIR SYS - CONTROL PANEL (SNGL)	1	1
2	2EL0281	RELAY THRML OVELOAD 26AMP	2	2
3	S-1158	SCREW TCSF #8 - 32 x 1/2 PHP ZN	23	25
4	2EL0243	40A CONTACTOR - MAGNETIC (CSA)	2	2
5	2EL0648	CONTACT - AUXILIARY MOTOR CONTACTOR	1	1
6	2EL0282	RELAY - THRML OVERLD (CSA) 86AMP	1	1
7	S-3674	WASHER FLAT #10 SAE ZN	2	2
8	2EL0248	CONTACTOR - MAGNETIC(CSA) 90 AMP	1	1
9	S-6557	SCREW TCSF #8 - 32 x 3/4 PHP ZN	6	6
10	2EL0307	TRANSFORMER - CURRENT 150:5RATIO	1	-
10	2EL0368	TRANSFORMER - CURRENT 200:5RATIO	-	1
11	2EL0273	RELAY - 3PDT 5A 120V DELTRO	1	1
12	801E047	TIMER - OFF DELAY, 15 SEC ASY	1	1
13	S-7124	SCREW TCSF #8 - 32 x 1 PHP ZN	1	1
14	1EL0909	PWR DIST. BLK 175A 600V 1P	1	1
15	C-8018	TERMINAL BLOCK 185A 3POLE 1:4	1	1
16	E160-1137	LUG GROUND - #TA-2 (CSA)	1	1
17	801E018	HIGH PRESSURE SWITCH ASY	1	1
18	1773	TERMINAL BLOCK 4 POLE 2 ROW	1	1
19	801L006	DECAL - TERMINAL STRIP	1	1
20	802L006	DECAL - AUXILIARY	1	1
21	802L005	DECAL - AIRLOCK	1	1
22	802L004	DECAL - BLOWER	1	1
23	801L003	DECAL - PRESSURE SWITCH	1	1
24	DC-889	DECAL - DANGER HIGH VOLTAGE ALL PF	1	1
25	2EL0308	TRANSFORMER - 460V - 120V.15KVA	1	1
26	AS-0211T	5AMP LIMIT TRANSFORMER - DIGITAL AMP	-	1

9. PARTS

CSA Control Panel Assembly - 460V 40-60 HP

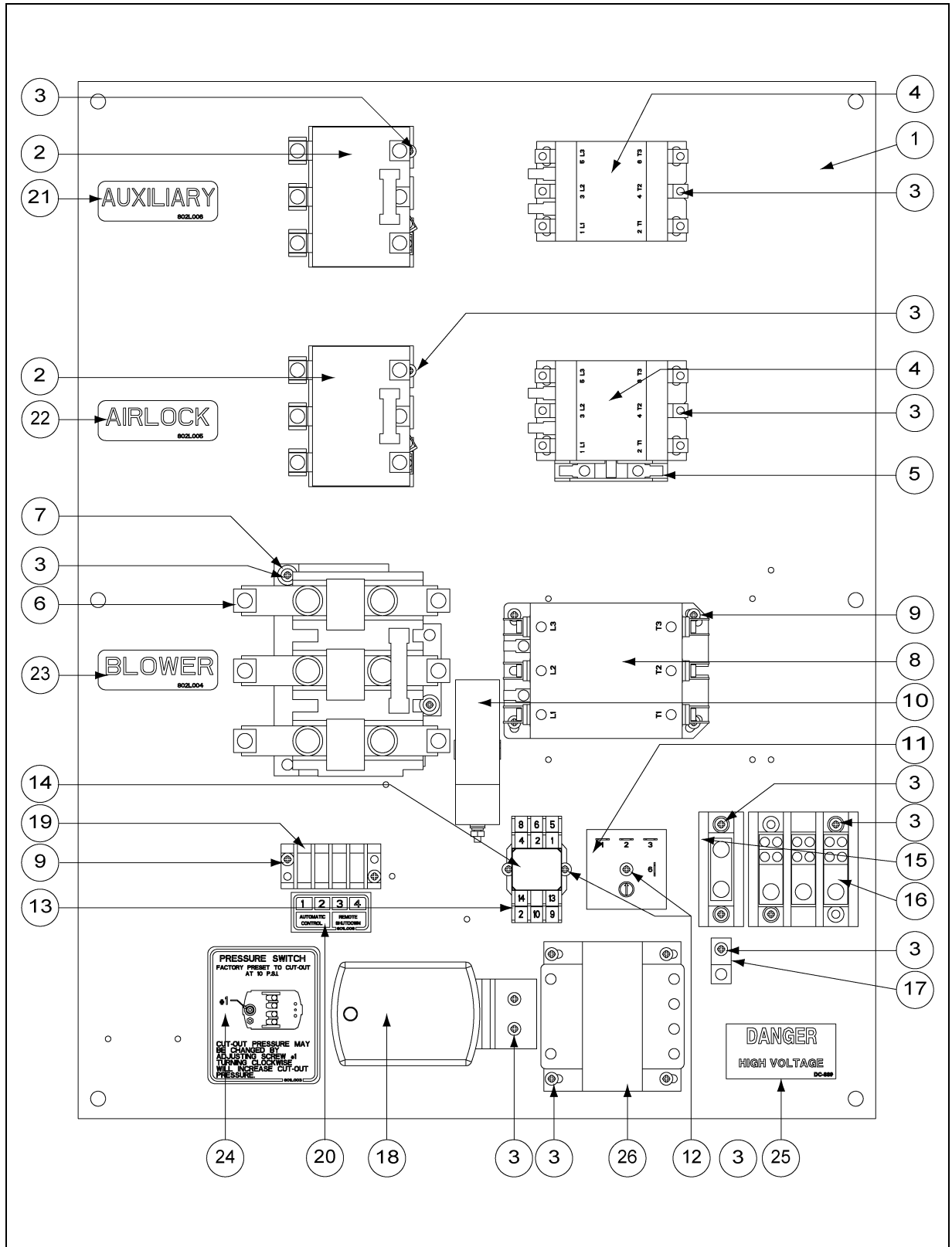

**CSA Control Panel Assembly - 460V 40-60 HP
Used In 8015072 Control Box (CSA Listed)**

REF #	PART #	DESCRIPTION	NEW CSA DESIGN QTY
1	8015079	AIR SYS-CONTROL PANEL (SNGL)	1
2	2EL0281	RELAY THRML OVELOAD 26AMP	2
3	S-1158	SCREW TCSF #8-32x1/2 PHP ZN	21
4	2EL0243	40A CONTACTOR - MAGNETIC(CSA)	2
5	2EL0648	CONTACT - AUXILIARY MOTOR CONTACTOR	1
6	2EL0282	RELAY - THRML OVERLD(CSA) 86AMP	1
7	S-3674	WASHER FLAT #10 SAE ZN	2
8	2EL0248	CONTACTOR - MAGNETIC(CSA) 90 AMP	1
9	S-6557	SCREW TCSF #8-32x3/4 PHP ZN	6
10	2EL0307	TRANSFORMER - CURRENT 150:5RATIO	1
11	801E047	TIMER - OFF DELAY, 15 SEC ASY	1
12	S-7124	SCREW TCSF #8-32x1 PHP ZN	3
13	7097555	RELAY BASE, 3PDT, SMALL SQUARE	1
14	HF-7203	RELAY 3PDT 120V RH3B-U IDEC	1
15	1EL0909	PWR DIST. BLK 175A 600V 1P	1
16	C-8018	TERMINAL BLOCK 185A 3POLE 1:4	1
17	E160-1137	LUG GROUND - #TA-2 (CSA)	1
18	801E018	HIGH PRESSURE SWITCH ASY	1
19	1773	TERMINAL BLOCK 4 POLE 2 ROW	1
20	801L006	DECAL - TERMINAL STRIP	1
21	802L006	DECAL - AUXILIARY	1
22	802L005	DECAL - AIRLOCK	1
23	802L004	DECAL - BLOWER	1
24	801L003	DECAL - PRESSURE SWITCH	1
25	DC-889	DECAL - DANGER HIGH VOLTAGE ALL PF	1
26	2EL0308	TRANSFORMER-460V - 120V .15KVA	1

9. PARTS

Control Panel Assembly - 460V 75HP

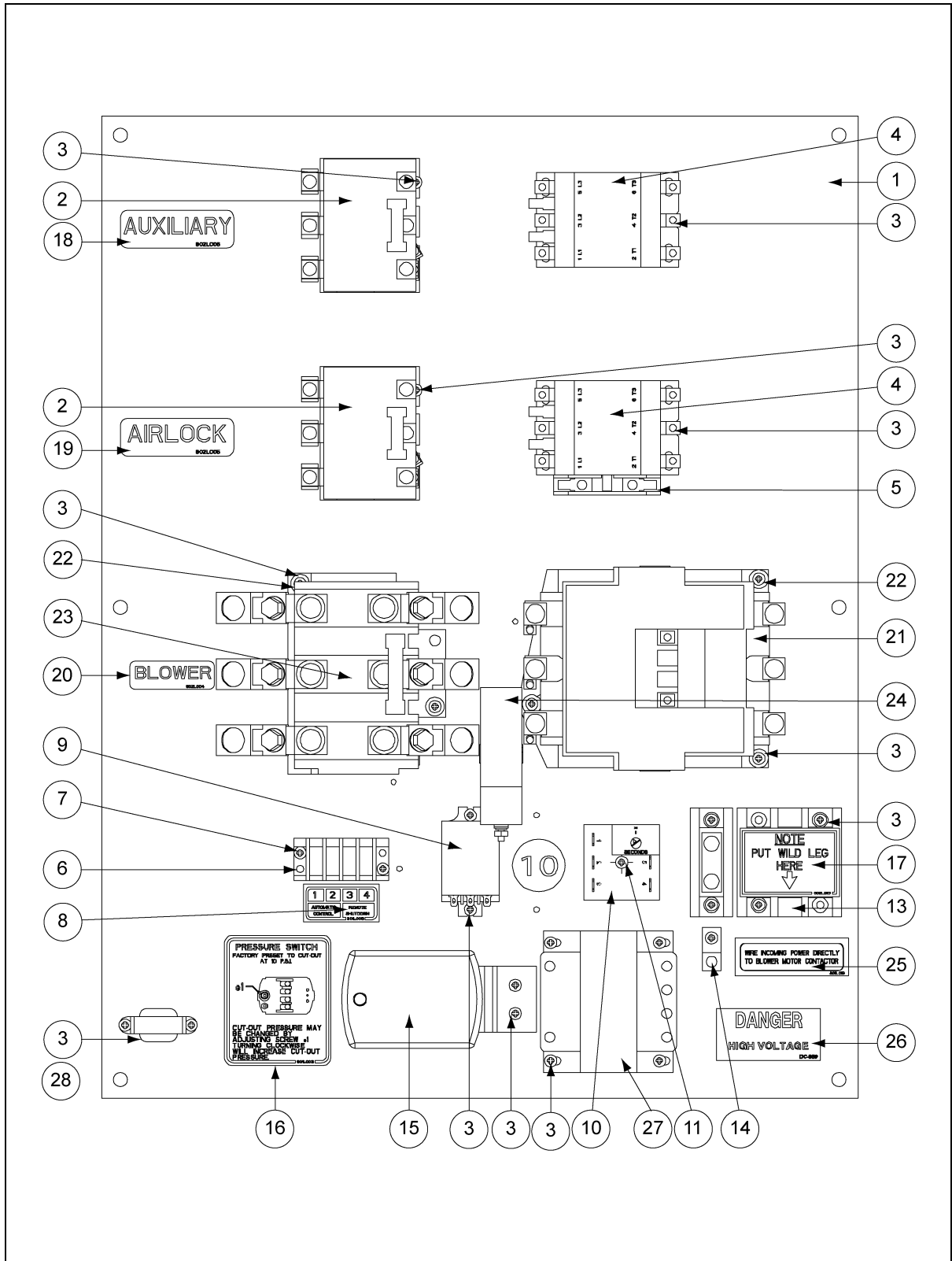

Control Panel Assembly - 460V 75 HP

REF #	PART #	DESCRIPTION	ANALOG QTY	DIGITAL QTY
1	8015079	AIR SYS - CONTROL PANEL (SNGL)	1	1
2	2EL0281	RELAY THRML OVELOAD 26AMP	2	2
3	S-1158	SCREW TCSF #8 - 32 x 1/2 PHP ZN	20	22
4	2EL0243	40A CONTACTOR - MAGNETIC (CSA)	2	2
5	2EL0648	CONTACT - AUXILIARY MOTOR CONTACTOR	1	1
6	1773	TERMINAL BLOCK 4 POLE 2 ROW	1	1
7	S-6557	SCREW TCSF #8 - 32 x 3/4 PHP ZN	2	2
8	801L006	DECAL - TERMINAL STRIP	1	1
9	2EL0273	RELAY - 3PDT 5A 120V DELTRO	1	1
10	801E047	TIMER - OFF DELAY, 15 SEC ASY	1	1
11	S-7124	SCREW TCSF #8 - 32 x 1 PHP ZN	1	1
12	1EL0909	PWR DIST. BLK 175A 600V 1P	1	1
13	C-8018	TERMINAL BLOCK 185A 3POLE 1:4	1	1
14	E160-1137	LUG GROUND, #TA-2 (CSA)	1	1
15	801E018	HIGH PRESSURE SWITCH ASY	1	1
16	801L003	DECAL - PRESSURE SWITCH	1	1
17	602L013	DECAL - WILD LEG	1	1
18	802L006	DECAL - AUXILIARY	1	1
19	802L005	DECAL - AIRLOCK	1	1
20	802L004	DECAL - BLOWER	1	1
21	2EL0249	CONTACTOR - 120AMP 120V COIL	1	1
22	S-3674	WASHER FLAT #10 SAE ZN	5	5
23	2EL0271	RELAY - OVERLOAD SIZE 4 133AMP	1	1
24	2EL0307	TRANSFORMER - CURRENT 150:5 RATIO	1	-
24	2EL0368	TRANSFORMER - CURRENT 200:5 RATIO	-	1
25	801L019	DECAL - WIRE INCOMING PWR	1	1
26	DC-889	DECAL, DANGER HIGH VOLTAGE ALL PF	1	1
27	2EL0308	TRANSFORMER - 460V - 120V.15KVA	1	1
28	AS-0211T	5AMP LIMIT TRANSFORMER-DIGITAL AMP	-	1

10. COUPLINGS

How to Handle Handling Couplings

1. Couplings are shipped ready-to-install... do not disassemble. To prevent gasket from slipping out of proper position, always grasp coupling as shown in [Figure 10A](#). This will save time by maintaining proper position of gasket and sleeve in relation to shell and flange.

Installing Couplings

1. Confirm pipe O.D. size you intend joining. Each compression coupling has been factory inspected for proper O.D. size before shipment.
2. Be sure outside surface of pipe is dry, and free of dirt, grease or external burrs. (Burrs & jagged pipe ends can cut gasket; dirt & grease can cause coupling slippage.)
3. Grasp coupling as shown in [Figure 10A](#) to keep gasket and sleeve (and gasket protector when used) in separate quadrants, as shown in [Figure 10A](#). Be sure gasket teeth mesh and do not overlap.
4. Slide coupling over one pipe past end, then butt pipe ends (a small gap 1/16 maximum at butt joint will not reduce coupling performance). Slide coupling back until coupling and gasket protector are centered over joint. Use care when sliding coupling into place...avoid wrinkling of gasket or gasket protector.
5. The gasket protector provides a bleed path for static electricity.
6. Partially tighten bolts evenly as follows:

1/2 bolt size - 45 ft. lbs. torque

5/8 bolt size - 65 ft. lbs. torque

3/4 bolt size - 95 ft. lbs. torque

(Where SAE GR 5 5/8 bolts are specified tighten to 95 ft. lbs. For couplings with aluminum shell and inner sleeve do not exceed 40 ft. lbs.)

7. When properly and evenly tightened to the recommended torque the coupling installation is complete. The top edges of the flanges will touch and flanges appear as a vee when viewed from the end, as shown in [Figure 10A](#). **DO NOT** attempt tightening bolts to flatten flange faces together, as this exceeds recommended limits.

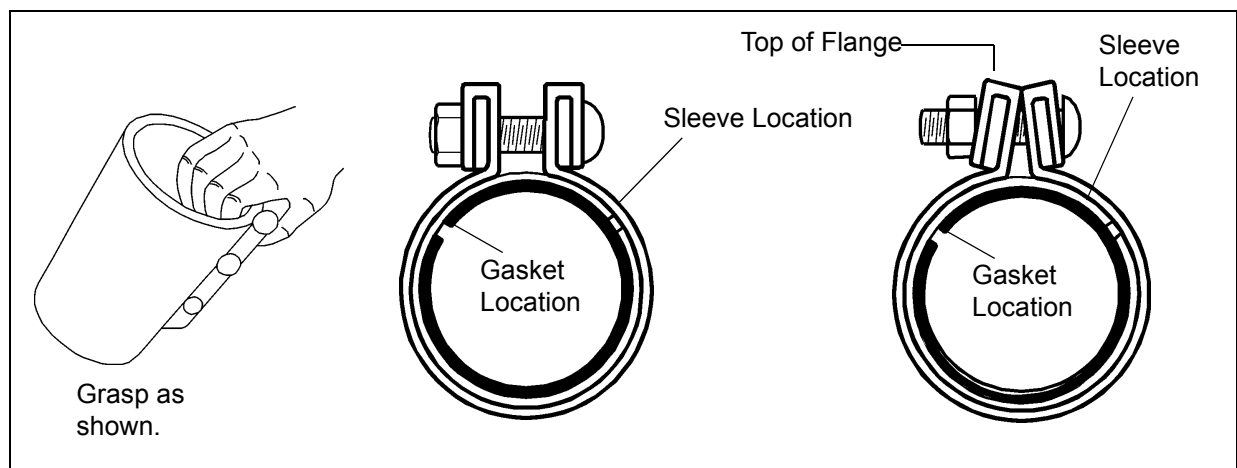



Figure 10A

11. TROUBLE SHOOTING

Problem	Solution
1. System Plugs Up	<ol style="list-style-type: none"> 1. Check belt tension on air blower and tighten if loose. 2. Check air filter and clean out. Locate in a place where there is less dust. 3. Check tubing system for any obstructions. 4. Reduce feed-in rate. 5. Air pressure switch setting may be too low. 6. Outlet gate valve too far open.
2. Excessive Grain Damage	<ol style="list-style-type: none"> 1. May be overfeeding airlock, causing vanes to shear off grain. Reduce feed rate. 2. Air velocity may be excessive. Slow air blower by changing pulleys or by opening gate valve. 3. Damage can occur if system is running at less than full capacity. Increase feed rate. 4. Rubber hose used to change grain direction, or used for extended lengths. 5. Airlock shear protector installed wrong.
3. Airlock Stops or is Noisy	<ol style="list-style-type: none"> 1. A foreign object may have become lodged in the airlock vanes. 2. Check belt tension. 3. Check gearbox drive. 4. The rotor vanes may be rubbing on the ends of the airlock. Check clearance at both ends of rotor and center in housing by loosening the set screws in the bearings on both ends of the rotor shaft and moving rotor. Tighten set screws after repositioning. 5. The rotor vanes may have become rusted to the airlock housing. The airlock can be broken loose by using a pipe wrench on the exposed rotor shaft. <p style="text-align: center;">  CAUTION  </p> <p>The worm drive gearbox <u>cannot</u> be driven in reverse and can be damaged. Remove the airlock drive chain before attempting to turn the airlock by hand.</p> <hr/> <ol style="list-style-type: none"> 6. "U" cup packings on rotor too tight. (Contact factory)

11. TROUBLE SHOOTING

Electrical Trouble Shooting

Problem	Solution
4. Unit will not start, "ready light" is not ON.	<ol style="list-style-type: none">1. Check AC power supply.2. Check control box fuses.3. Thermal overload tripped (overload indicator is ON).4. Air pressure limit switch may be misadjusted (less than 5 PSI). If pressure switch is not reset, turn pressure adjustment clockwise until switch resets.5. Be sure "START" switch is pushed.
5. Unit will not start, the "ready light" is ON.	<ol style="list-style-type: none">1. Blower, airlock and auxiliary switches must be in either "AUTO" or "MANUAL" to operate.2. The automatic control not wired correctly or not working. (Requires a closed contact across TB1 and TB2 to auto start).
6. Blower Motor Trips Thermal Overload	<ol style="list-style-type: none">1. Check current draw using Amp meter. The motor should not be pulling more current than the name plate specifies. Reduce feed rate if excessive.2. Check heater sizes.3. Check for loose connections and/or too small gauge wire.4. Wrong voltage (either high or low).5. Too much load due to obstructions, bad bearings or dry gears.
7. No Control Voltage	<ol style="list-style-type: none">1. Control Fuse inside the control box is down.2. Check main power for proper voltage.

GSI Group, LLC Limited Warranty

The GSI Group, LLC ("GSI") warrants products which it manufactures to be free of defects in materials and workmanship under normal usage and conditions for a period of 12 months after sale to the original end-user or if a foreign sale, 14 months from arrival at port of discharge, whichever is earlier. The end-user's sole remedy (and GSI's only obligation) is to repair or replace, at GSI's option and expense, products that in GSI's judgment, contain a material defect in materials or workmanship. Expenses incurred by or on behalf of the end-user without prior written authorization from the GSI Warranty Group shall be the sole responsibility of the end-user.

Warranty Extensions:

The Limited Warranty period is extended for the following products:

	Product	Warranty Period	
AP Fans and Flooring	Performer Series Direct Drive Fan Motor	3 Years	* Warranty prorated from list price: 0 to 3 years - no cost to end-user 3 to 5 years - end-user pays 25% 5 to 7 years - end-user pays 50% 7 to 10 years - end-user pays 75%
	All Fiberglass Housings	Lifetime	
	All Fiberglass Propellers	Lifetime	
Cumberland Feeding/Watering Systems	Feeder System Pan Assemblies	5 Years **	** Warranty prorated from list price: 0 to 3 years - no cost to end-user 3 to 5 years - end-user pays 50%
	Feed Tubes (1-3/4" and 2.00")	10 Years *	
	Centerless Augers	10 Years *	
	Watering Nipples	10 Years *	
Grain Systems	Grain Bin Structural Design	5 Years	
Grain Systems Farm Fans Zimmerman	Portable and Tower Dryers	2 Years	† Motors, burner components and moving parts not included. Portable dryer screens included. Tower dryer screens not included.
	Portable and Tower Dryer Frames and Internal Infrastructure †	5 Years	

GSI further warrants that the portable and tower dryer frame and basket, excluding all auger and auger drive components, shall be free from defects in materials for a period of time beginning on the twelfth (12th) month from the date of purchase and continuing until the sixtieth (60th) month from the date of purchase (extended warranty period). During the extended warranty period, GSI will replace the frame or basket components that prove to be defective under normal conditions of use without charge, excluding the labor, transportation, and/or shipping costs incurred in the performance of this extended warranty.

Conditions and Limitations:

THERE ARE NO WARRANTIES THAT EXTEND BEYOND THE LIMITED WARRANTY DESCRIPTION SET FORTH ABOVE. SPECIFICALLY, GSI MAKES NO FURTHER WARRANTY OF ANY KIND, EXPRESS OR IMPLIED, INCLUDING, WITHOUT LIMITATION, WARRANTIES OF MERCHANTABILITY OR FITNESS FOR A PARTICULAR PURPOSE OR USE IN CONNECTION WITH: (I) PRODUCT MANUFACTURED OR SOLD BY GSI OR (II) ANY ADVICE, INSTRUCTION, RECOMMENDATION OR SUGGESTION PROVIDED BY AN AGENT, REPRESENTATIVE OR EMPLOYEE OF GSI REGARDING OR RELATED TO THE CONFIGURATION, INSTALLATION, LAYOUT, SUITABILITY FOR A PARTICULAR PURPOSE, OR DESIGN OF SUCH PRODUCTS.

GSI shall not be liable for any direct, indirect, incidental or consequential damages, including, without limitation, loss of anticipated profits or benefits. The sole and exclusive remedy is set forth in the Limited Warranty, which shall not exceed the amount paid for the product purchased. This warranty is not transferable and applies only to the original end-user. GSI shall have no obligation or responsibility for any representations or warranties made by or on behalf of any dealer, agent or distributor.

GSI assumes no responsibility for claims resulting from construction defects or unauthorized modifications to products which it manufactured. Modifications to products not specifically delineated in the manual accompanying the equipment at initial sale will void the Limited Warranty.

This Limited Warranty shall not extend to products or parts which have been damaged by negligent use, misuse, alteration, accident or which have been improperly/inadequately maintained. This Limited Warranty extends solely to products manufactured by GSI.

Prior to installation, the end-user has the responsibility to comply with federal, state and local codes which apply to the location and installation of products manufactured or sold by GSI.

This equipment shall be installed in accordance with the current installation codes and applicable regulations which should be carefully followed in all cases. Authorities having jurisdiction should be consulted before installations are made.

G S I G R O U P



GSI Group, Inc.
1004 E. Illinois St.
Assumption, IL 62510-0020
Phone: 1-217-226-4421
Fax: 1-217-226-4420
Internet: <http://www.grainsystems.com>