



Assembly Instructions

These truss kits are designed to provide support for air system tube sections up to 40' in length.

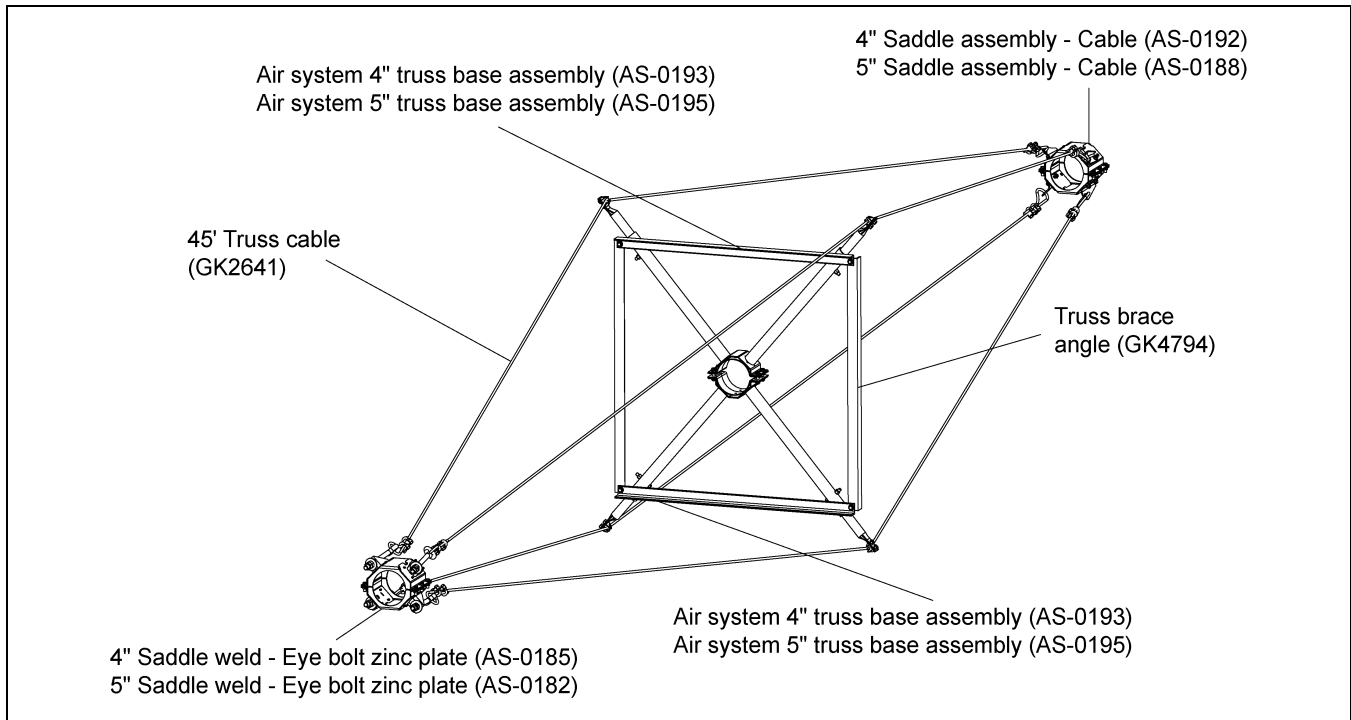

Figure 1

- Step 1:** Locate the truss base assemblies (Ref #1) in the center of the tube that is to be trussed as shown in [Figure 1](#). Be sure the angles on the base assemblies are oriented in the same direction as noted. ([See Figure 2 on Page 2.](#)) Fasten the truss bases to the tube with hardware Ref #2, #3 and #4. ([See Figure 2 on Page 2.](#))
- Step 2:** Place truss braces (Ref #5) between the truss base assemblies and orient as shown. Attach using hardware Ref #2, #4 and #6. ([See Figure 2 on Page 2.](#))
- Step 3:** Position the cable saddle assemblies (Ref #11) and the eye bolt saddle weldments (Ref #7) on opposite ends of the tube ([See Figure 1](#)) as close to the ends as possible but without interfering with the compression couplers. Be sure to orient the saddle assemblies as shown in [Figure 3 on Page 3](#) and install with hardware Ref #4 and #6.
- Step 4:** Install the eye bolts (Ref #8) through the anchors on the eye bolt saddle weldments as shown in [Figure 3 on Page 3](#). Make sure the eye is pointing toward the center of the tube. Fasten the eye bolts using hardware Ref #9 and #10. Leave hardware loose for later cable adjustment.
- Step 5:** Run cables through the chain connectors on the cable saddle assemblies and fasten with two (2) 5/16" cable clamps (Ref #13) as shown in [Figure 3 on Page 3](#).
- NOTE:** *Secure the U-bolt of the clamps against the loose end of the cable.*
- Step 6:** Loosen the 3/8" cable clamps on the tube base assemblies and route the cables through these cable clamps to the eye bolt saddle weldments. **DO NOT** tighten 3/8" cable clamps at this time.



4" and 5" Truss Kits for 40' Spans

Step 7: Loop cables through eye bolts and fasten with two (2) 5/16" cable clamps (Ref #13) as shown in [Figure 3 on Page 3](#).

NOTE: Secure the U-bolt of the clamps against the loose end of the cable.

Step 8: Using the eye bolts, tighten the cables to remove slack. Tighten all cables so they have the same amount of tension. **DO NOT** overtighten. Sight down the tube to make sure it is straight. Once adjustments are made, tighten the double 5/8" nuts (Ref #10) to lock the eye bolts in place.

Step 9: Tighten the 3/8" cable clamps that hold the cables to the tube base assemblies. Installation is now complete.

NOTE: Saddle assemblies should be skip welded to the tube to prevent slipping.

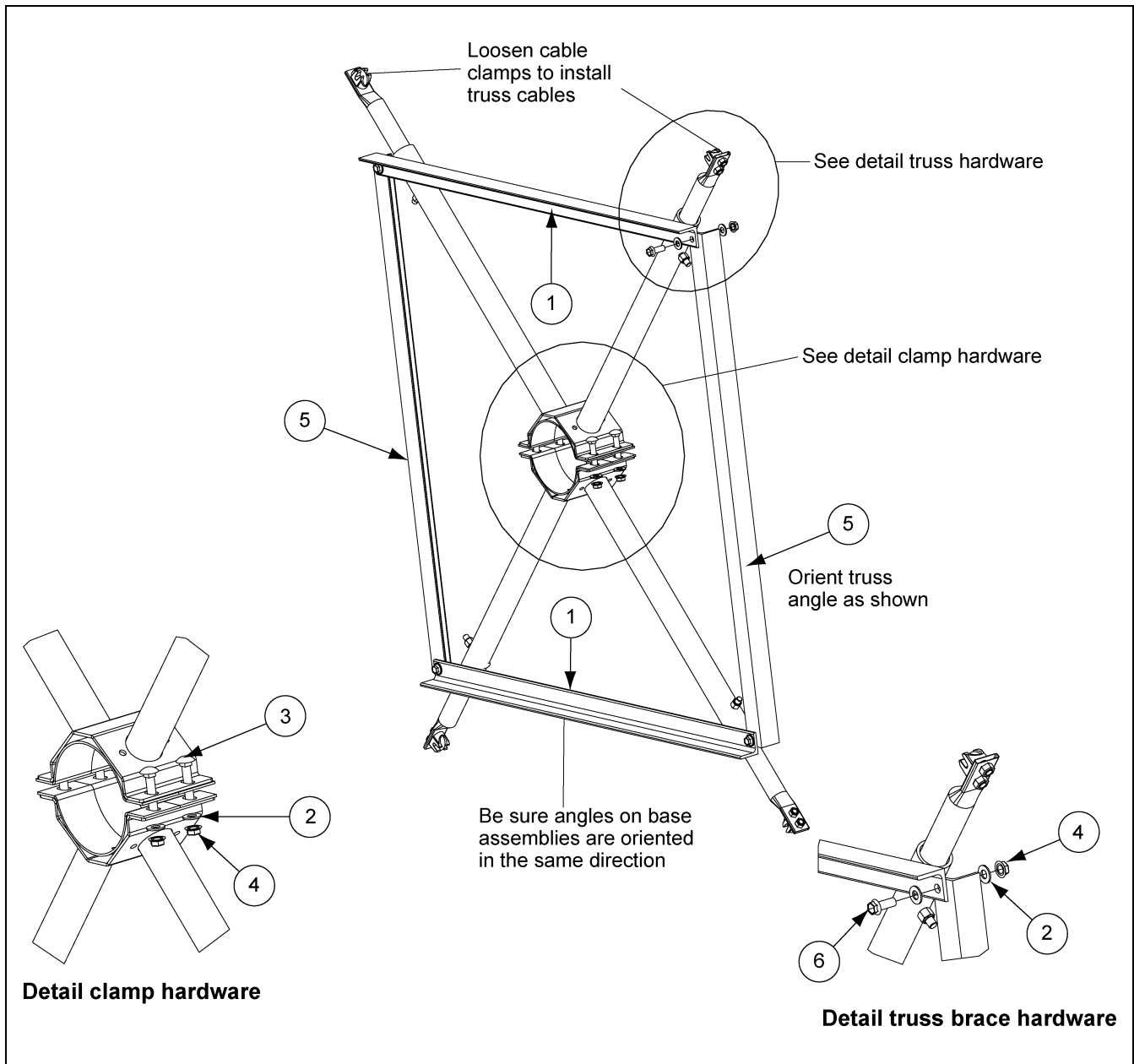

Figure 2 Installation of Tube Base Assemblies

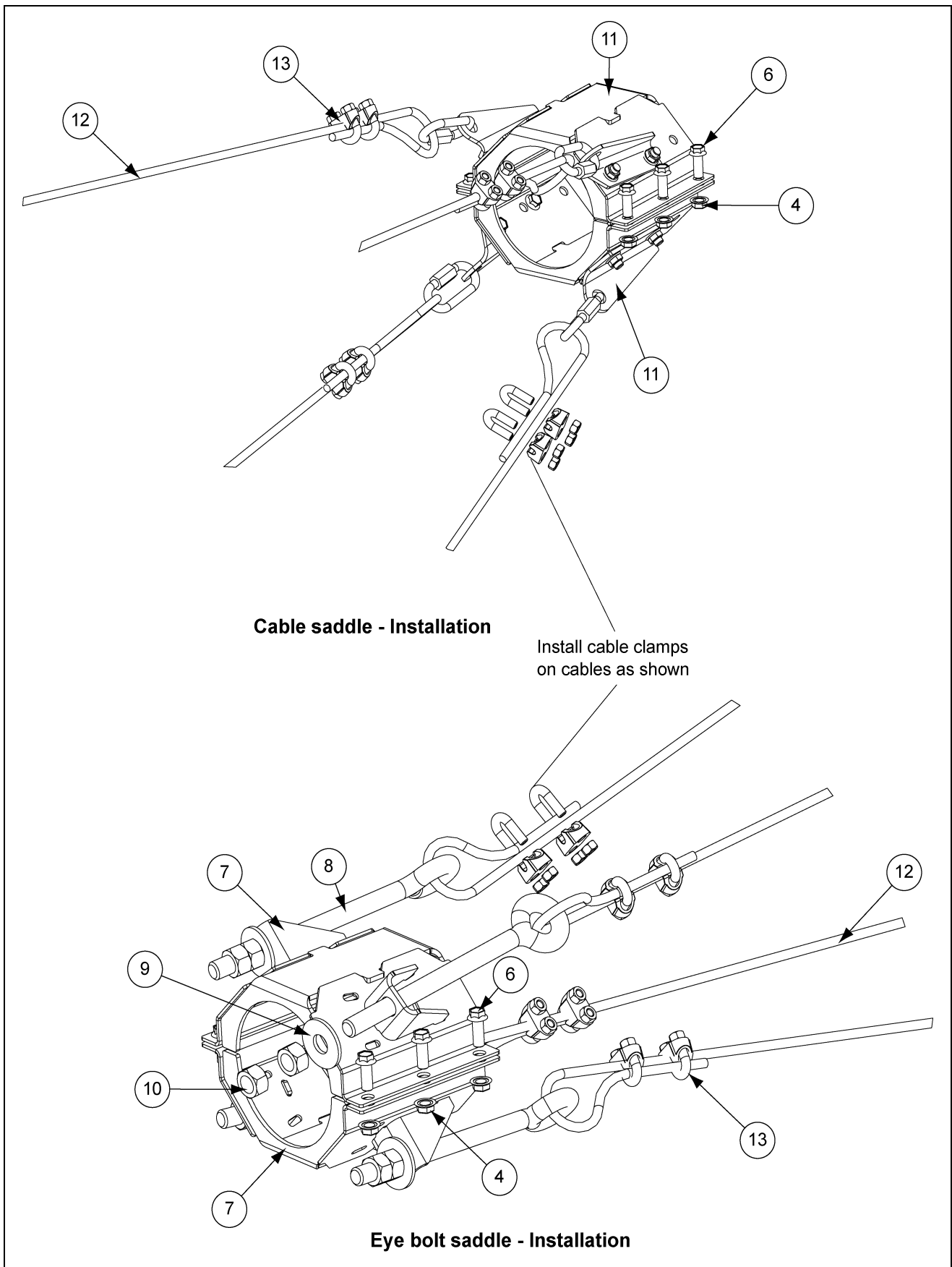

Figure 3

4" and 5" Truss Kits for 40' Spans

Tube Truss Kits Parts List

Ref #	Part #	Description	Qty	
			4"	5"
1	AS-0193	Air System 4" Truss Base Assembly	2	
1	AS-0195	Air System 5" Truss Base Assembly		2
2	S-248	Flat Washer 3/8" USS ZN YDP Grade 2	12	12
3	S-9082	Carriage Bolt 3/8"-16 x 2" ZN Grade 5	4	4
4	S-968	Flange Nut 3/8"-16 ZN Grade 5	20	20
5	GK4794	Truss Brace Angle	2	2
6	S-9065	Flange Bolt 3/8"-16 x 1" ZN Grade 5	16	16
7	AS-0185	4" Saddle Weld - Eye Bolt Zinc Plate	2	
7	AS-0182	5" Saddle Weld - Eye Bolt Zinc Plate		2
8	S-10115	Eye Bolt 5/8"-11 x 13" Grade 2 ZN Weld	4	4
9	S-858	Flat Washer 5/8" USS ZN	4	4
10	S-7597	Hex Nut 5/8"-11	8	8
11	AS-0192	4" Saddle Assembly - Cable	2	
11	AS-0188	5" Saddle Assembly - Cable		2
12	GK2641	Cable: Truss - 5/16" x 45' Long	4	4
13	GK2760	Clamp Cable 5/16"	16	16

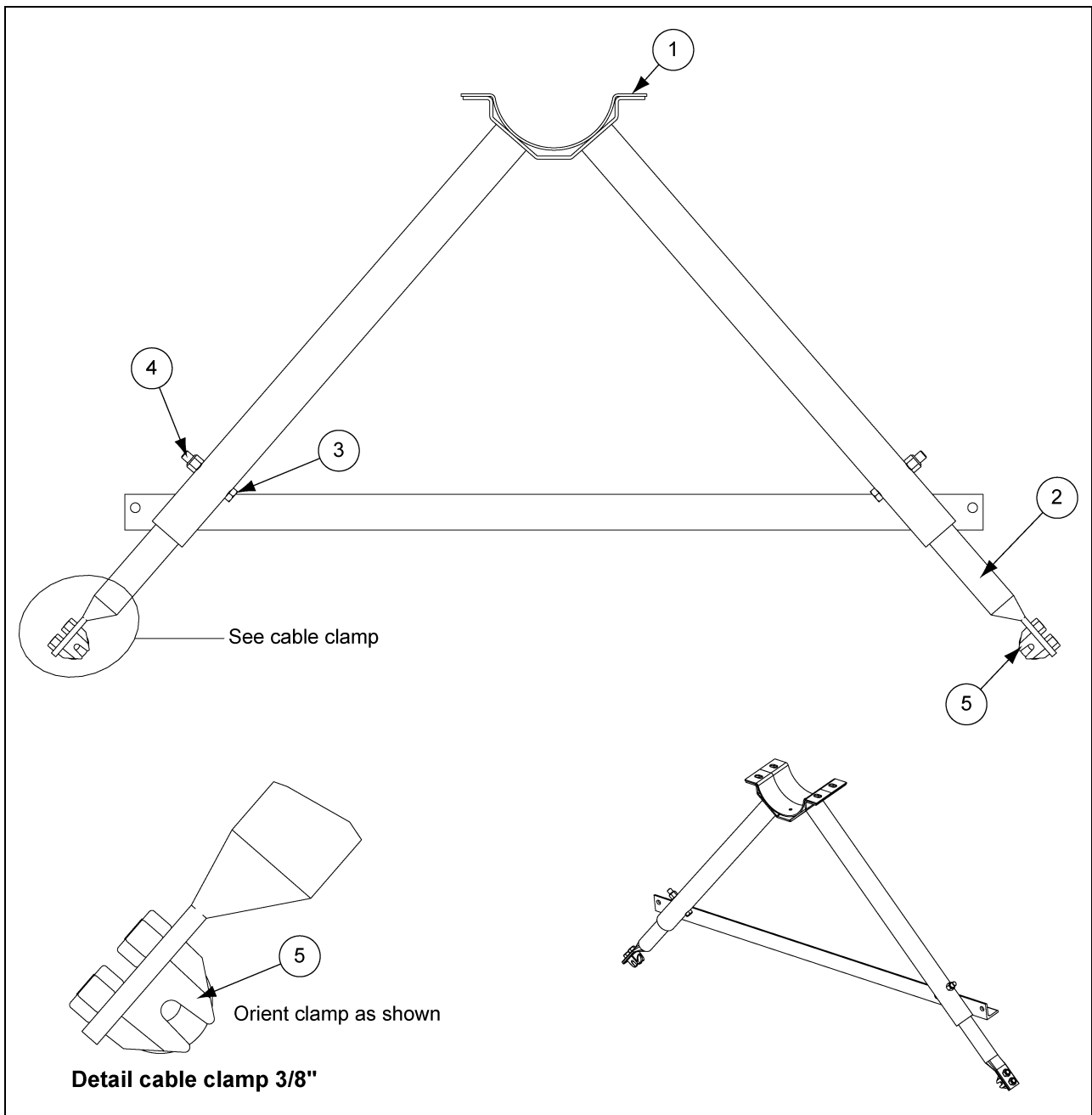

Figure 4 Tube Base Assemblies

Tube Assembly Bases Parts List

Ref #	Part #	Description	Qty	
			4"	5"
1	AS-0177-RD	Air System 4" Truss Base Weld - Red	1	
1	AS-0176-RD	Air System 5" Truss Base Weld - Red		1
2	GK4796	21" Truss Extension Tube	2	2
3	S-6762	Bolt HHCS 3/8"-16 x 2-1/2" ZN Grade 5	2	2
4	S-7383	Nylock Nut 3/8"-16 ZN Grade 5	2	2
5	GK2759	Clamp Cable Assembly 3/8"	2	2