



Assembly Instructions

These truss kits are designed to provide support for air system tube sections up to 40' in length.

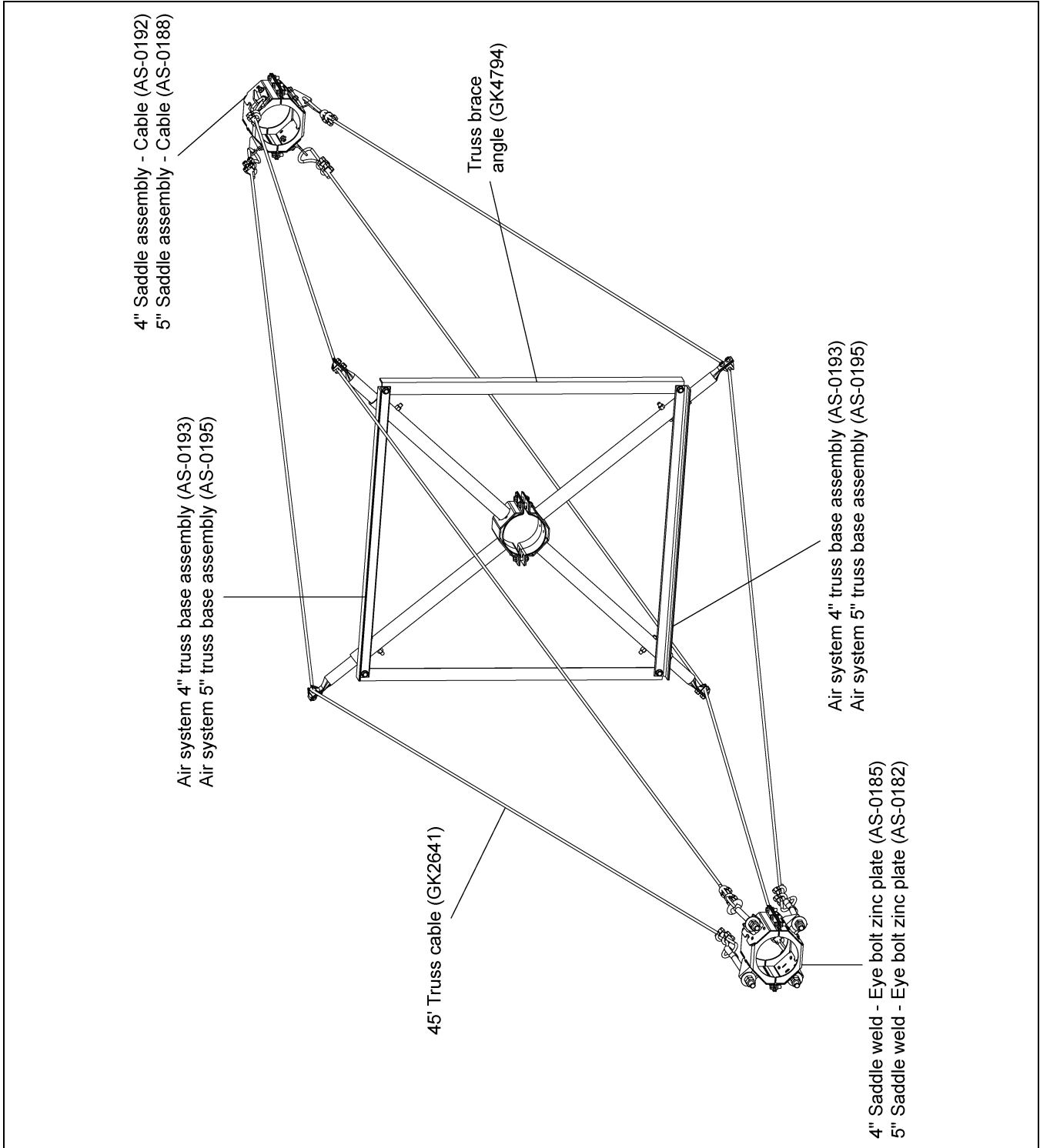

Figure 1

Date: 04-28-11

Printed in the U.S.A.
Copyright © 2011 by GSI Group
www.gsiag.com



PNEG-1449

Page 1 of 8

4" and 5" Truss Kits for 40' Spans

- Step 1:** Locate the truss base assemblies (Ref #1) in the center of the tube that is to be trussed as shown in [Figure 1 on Page 1](#). Be sure the angles on the base assemblies are oriented in the same direction as noted. ([See Figure 2 on Page 3.](#)) Fasten the truss bases to the tube with hardware Ref #2, #3 and #4. ([See Figure 2 on Page 3.](#))
- Step 2:** Place truss braces (Ref #5) between the truss base assemblies and orient as shown. Attach using hardware Ref #2, #4 and #6. ([See Figure 2 on Page 3.](#))
- Step 3:** Position the cable saddle assemblies (Ref #11) and the eye bolt saddle weldments (Ref #7) on opposite ends of the tube ([See Figure 1 on Page 1](#)) as close to the ends as possible but without interfering with the compression couplers. Be sure to orient the saddle assemblies as shown in [Figure 3 on Page 4](#) and install with hardware Ref #4 and #6.
- Step 4:** Install the eye bolts (Ref #8) through the anchors on the eye bolt saddle weldments as shown in [Figure 3 on Page 4](#). Make sure the eye is pointing toward the center of the tube. Fasten the eye bolts using hardware Ref #9 and #10. Leave hardware loose for later cable adjustment.
- Step 5:** Run cables through the chain connectors on the cable saddle assemblies and fasten with two (2) 5/16" cable clamps (Ref #13) as shown in [Figure 3 on Page 4](#).
- NOTE:** *Secure the U-bolt of the clamps against the loose end of the cable.*
- Step 6:** Loosen the 3/8" cable clamps on the tube base assemblies and route the cables through these cable clamps to the eye bolt saddle weldments. **DO NOT** tighten 3/8" cable clamps at this time.
- Step 7:** Loop cables through eye bolts and fasten with two (2) 5/16" cable clamps (Ref #13) as shown in [Figure 3 on Page 4](#).
- NOTE:** *Secure the U-bolt of the clamps against the loose end of the cable.*
- Step 8:** Using the eye bolts, tighten the cables to remove slack. Tighten all cables so they have the same amount of tension. **DO NOT** overtighten. Sight down the tube to make sure it is straight. Once adjustments are made, tighten the double 5/8" nuts (Ref #10) to lock the eye bolts in place.
- Step 9:** Tighten the 3/8" cable clamps that hold the cables to the tube base assemblies. Installation is now complete.

NOTE: *Saddle assemblies should be skip welded to the tube to prevent slipping.*

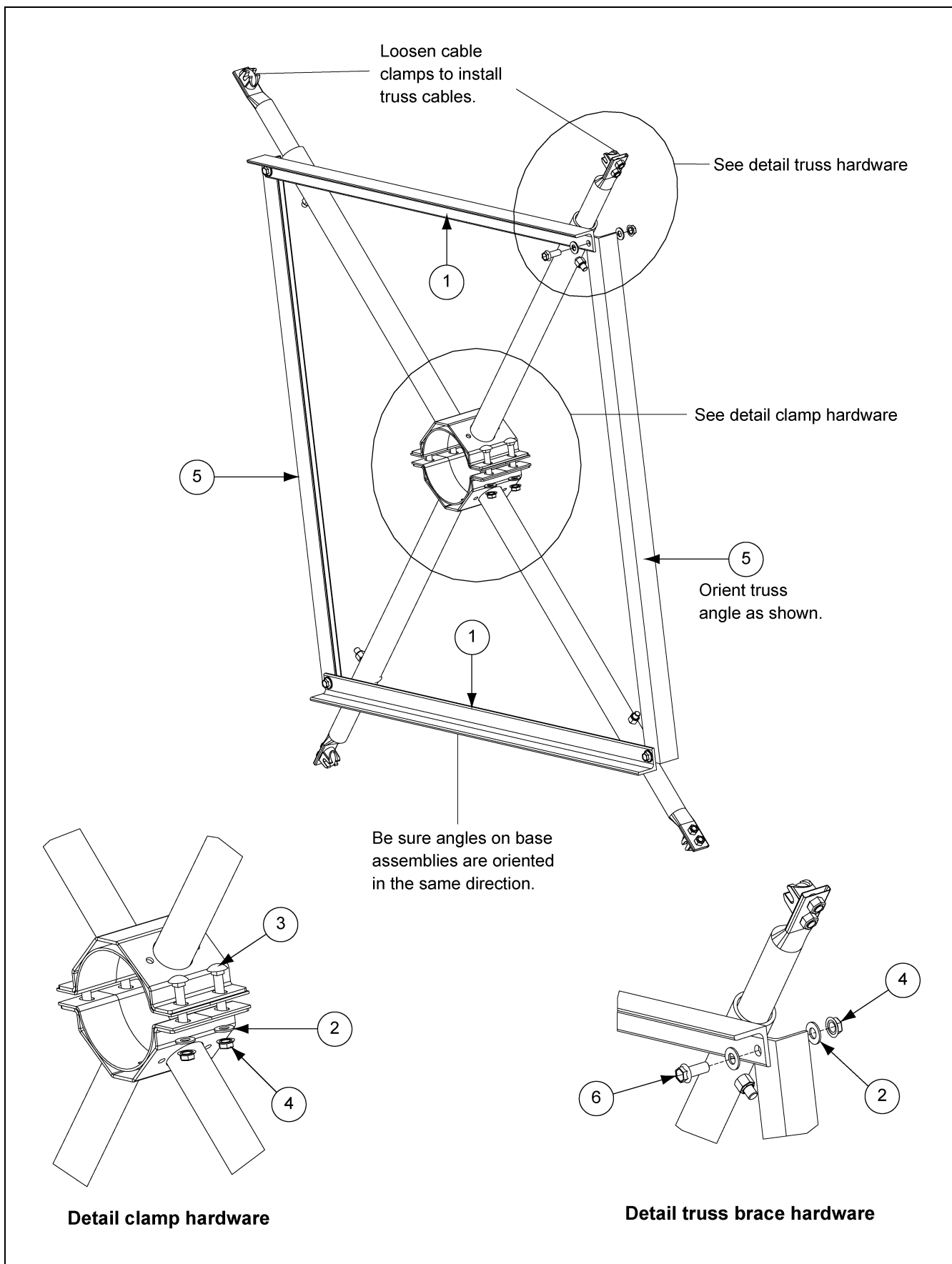

Figure 2 Installation of Tube Base Assemblies

4" and 5" Truss Kits for 40' Spans

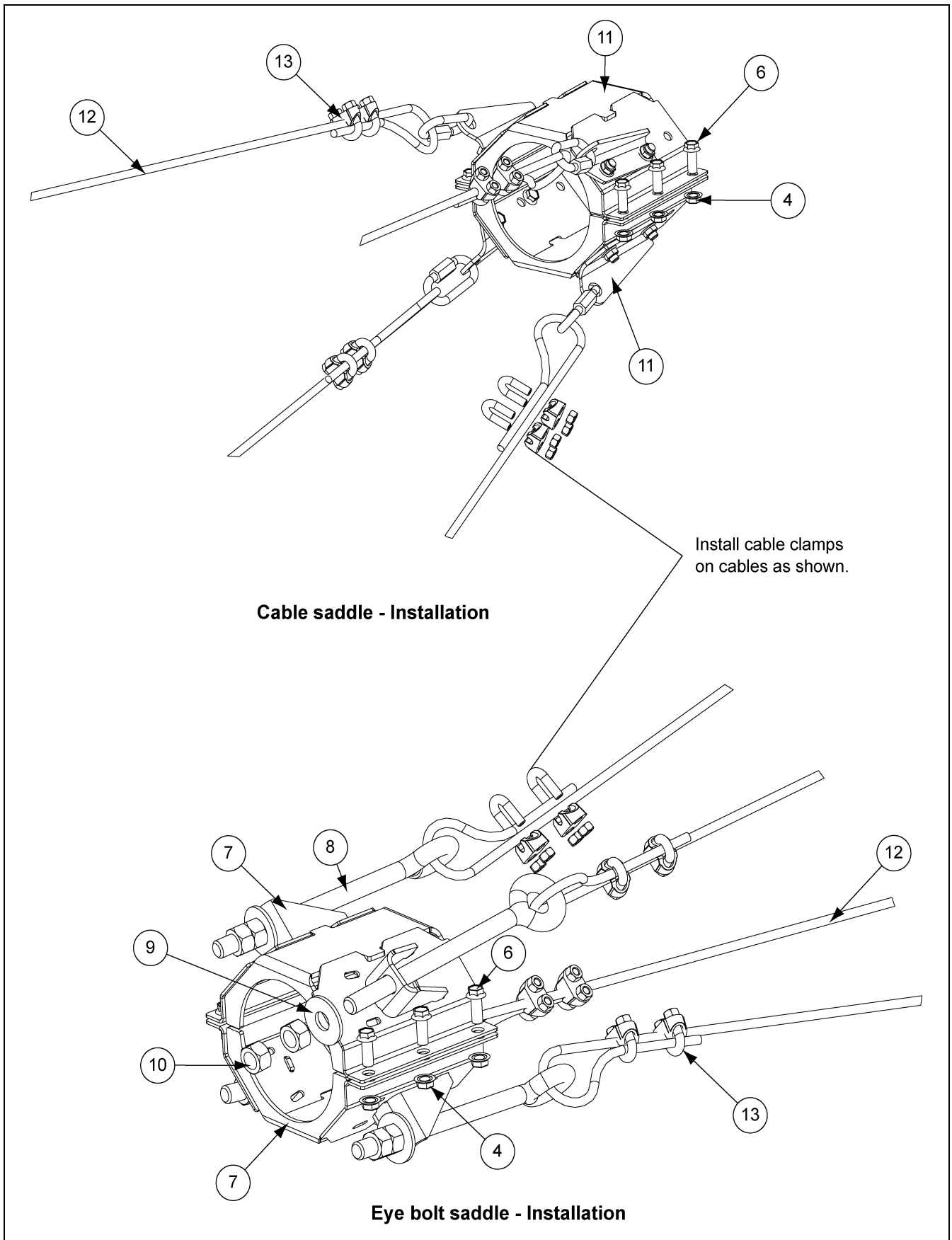

Figure 3

4" and 5" Truss Kits for 40' Spans

Tube Truss Kits Parts List

Ref #	Part #	Description	Qty	
			4"	5"
1	AS-0193	Air System 4" Truss Base Assembly	2	
1	AS-0195	Air System 5" Truss Base Assembly		2
2	S-248	Flat Washer 3/8" USS ZN YDP Grade 2	12	12
3	S-9082	Carriage Bolt 3/8"-16 x 2" ZN Grade 5	4	4
4	S-968	Flange Nut 3/8"-16 ZN Grade 5	20	20
5	GK4794	Truss Brace Angle	2	2
6	S-9065	Flange Bolt 3/8"-16 x 1" ZN Grade 5	16	16
7	AS-0185	4" Saddle Weld - Eye Bolt Zinc Plate	2	
7	AS-0182	5" Saddle Weld - Eye Bolt Zinc Plate		2
8	S-10115	Eye Bolt 5/8"-11 x 13" Grade 2 ZN Weld	4	4
9	S-858	Flat Washer 5/8" USS ZN	4	4
10	S-7597	Hex Nut 5/8"-11	8	8
11	AS-0192	4" Saddle Assembly - Cable	2	
11	AS-0188	5" Saddle Assembly - Cable		2
12	GK2641	Cable: Truss - 5/16" x 45' Long	4	4
13	GK2760	Clamp Cable 5/16"	16	16

4" and 5" Truss Kits for 40' Spans

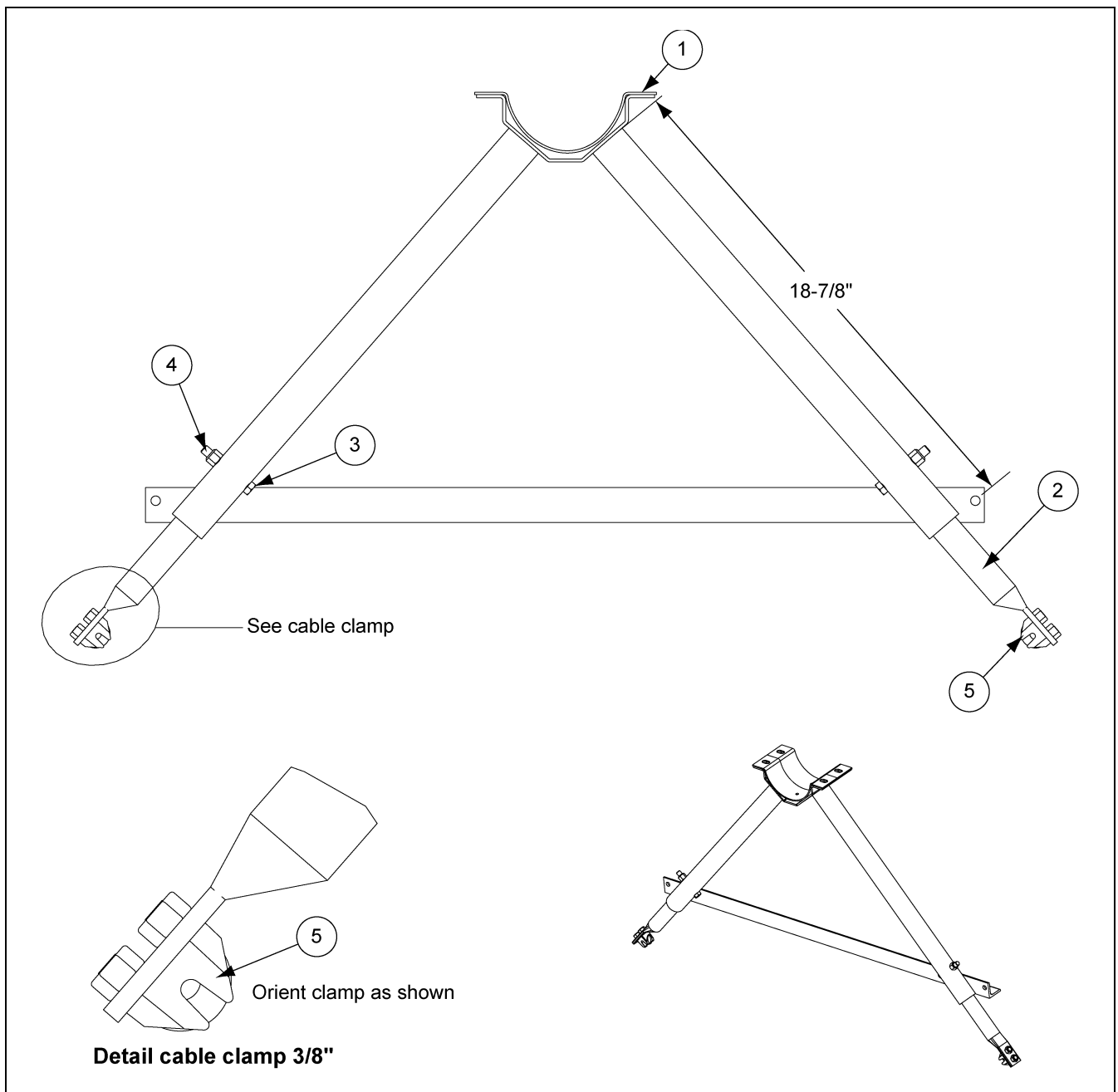

Figure 4 Tube Base Assemblies

Tube Assembly Bases Parts List

Ref #	Part #	Description	Qty	
			4"	5"
1	AS-0177-RD	Air System 4" Truss Base Weld - Red	1	
1	AS-0176-RD	Air System 5" Truss Base Weld - Red		1
2	GK4796	30" Truss Extension Tube	2	2
3	S-6762	Bolt, HHCS 3/8"-16 x 2-1/2" ZN Grade 5	2	2
4	S-7383	Nylock Nut 3/8"-16 ZN Grade 5	2	2
5	GK2759	Clamp Cable Assembly 3/8"	2	2

NOTES

This equipment shall be installed in accordance with the current installation codes and applicable regulations which should be carefully followed in all cases. Authorities having jurisdiction should be consulted before installations are made.

G S I G R O U P



GSI Group
1004 E. Illinois St.
Assumption, IL 62510-0020
Phone: 1-217-226-4421
Fax: 1-217-226-4420
www.gsiag.com