



Secure the motor mount from both sides to prevent the drive unit from pivoting either direction on the shaft.

NOTE: Motor mount and belt guard removed for clarity.

Attach both torque plate assemblies to each side of the gear reducer using the bolts provided. Re-use the lock washer and hex nut provided with the gear reducer. (See Figure 1.)

NOTE: Leave the hardware loose to allow for ease of assembly.

TA3 - 3/8"-16 Bolt

TA4 and TA5 - 1/2"-13 Bolt

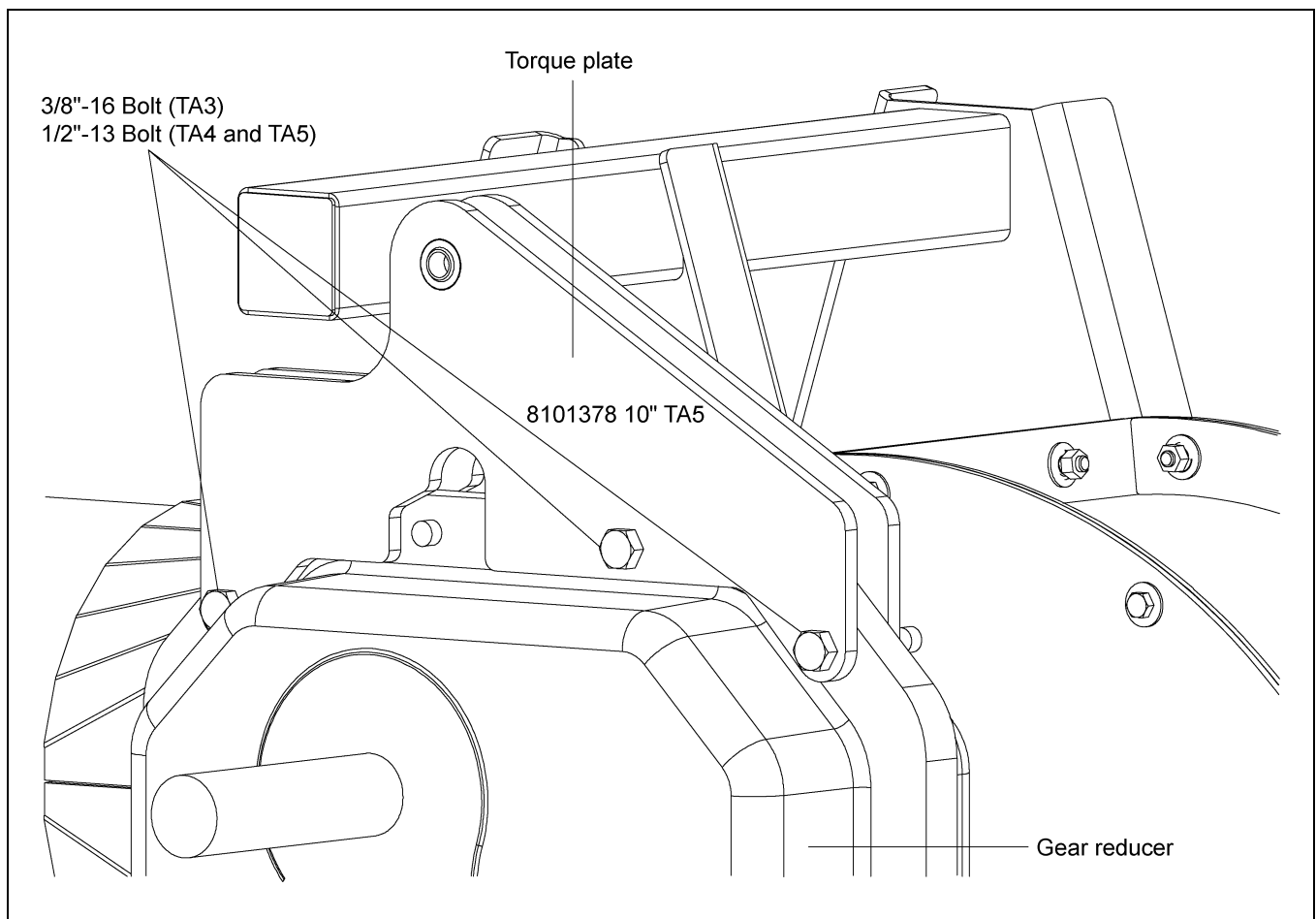

Figure 1



Chain Loop Torque Arm Repair Kit

Place the C-clamp bracket to the back side of the square tubing. (See Figure 2.)

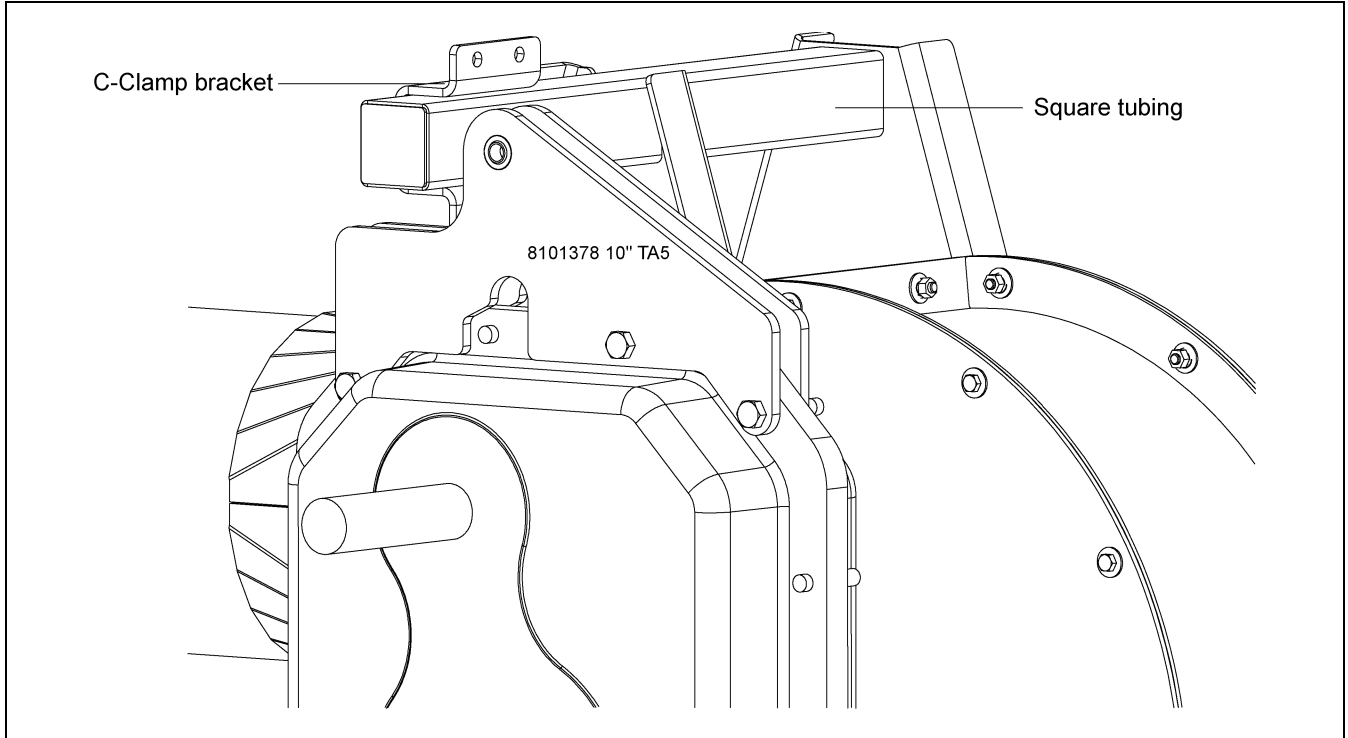

Figure 2

Place the torque plate anchor bracket between the torque plate assemblies and attach it to the C-clamp using the 3/8"-16 hardware. (See Figure 3.)

NOTE: Leave the hardware loose to allow for ease of assembly.

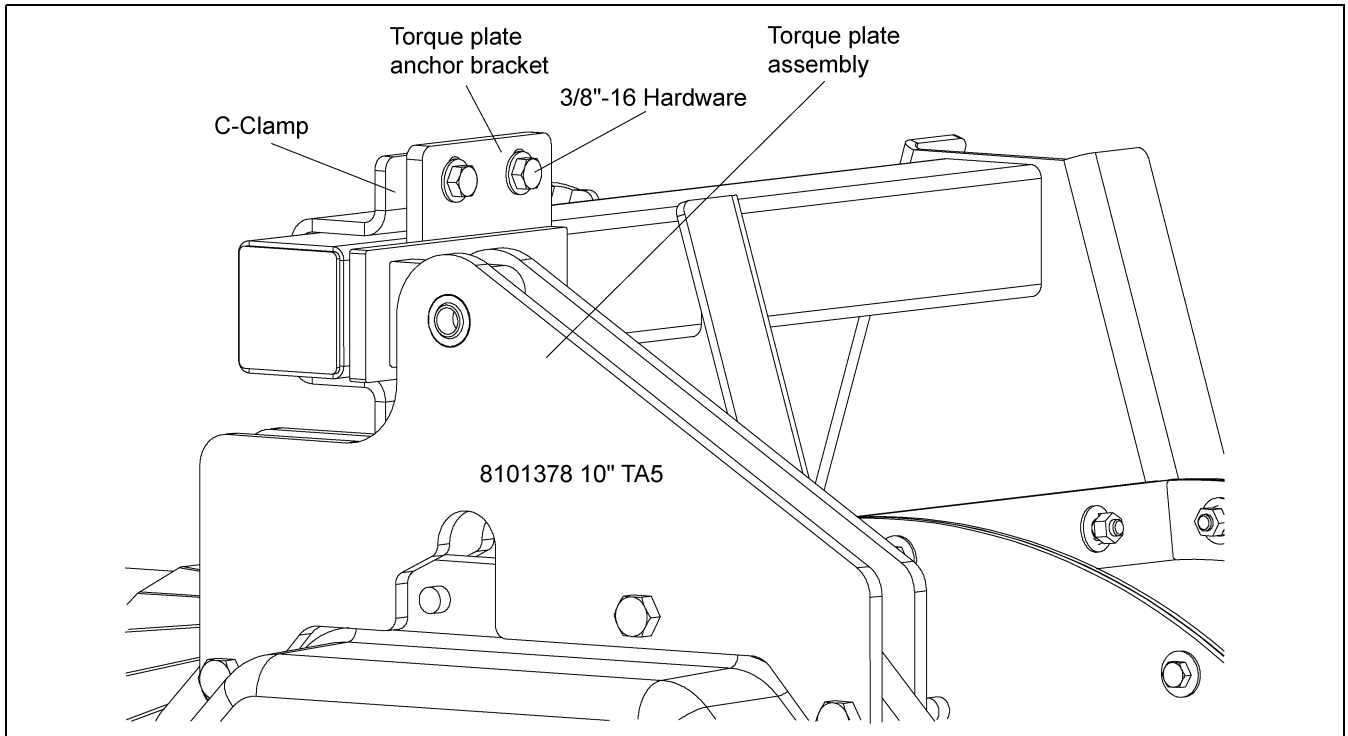

Figure 3

Chain Loop Torque Arm Repair Kit

Attach the torque plate anchor bracket to the torque plates using the two (2) 1/2" flat washers, shoulder bolt and 3/8"-16 nylock nut.

Tighten the hardware attaching the torque plate assemblies to the gear reducer after tightening the shoulder bolt hardware. (See Figure 4.)

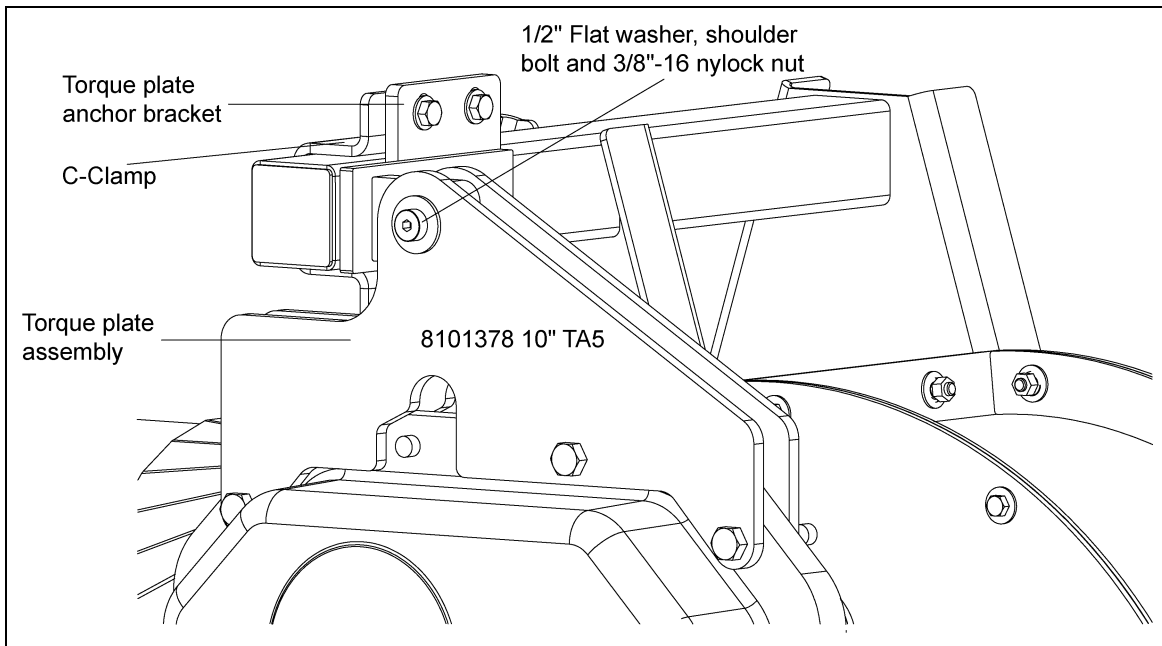

Figure 4

Move the torque plate anchor bracket on the square tube so the torque plate assemblies are aligned vertical. Once aligned, the 3/8"-16 hardware attaching the torque plate anchor bracket to the C-clamp can be tightened. (See Figure 5.)

NOTE: Washers must be on the outside of each torque plate assembly.

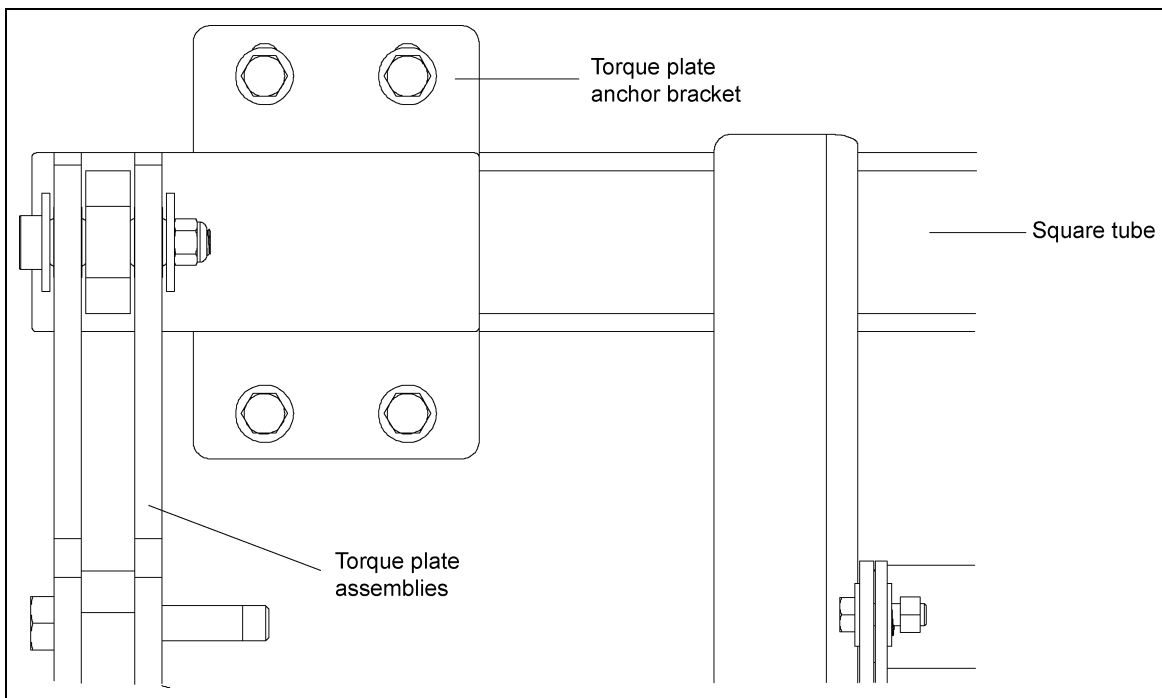
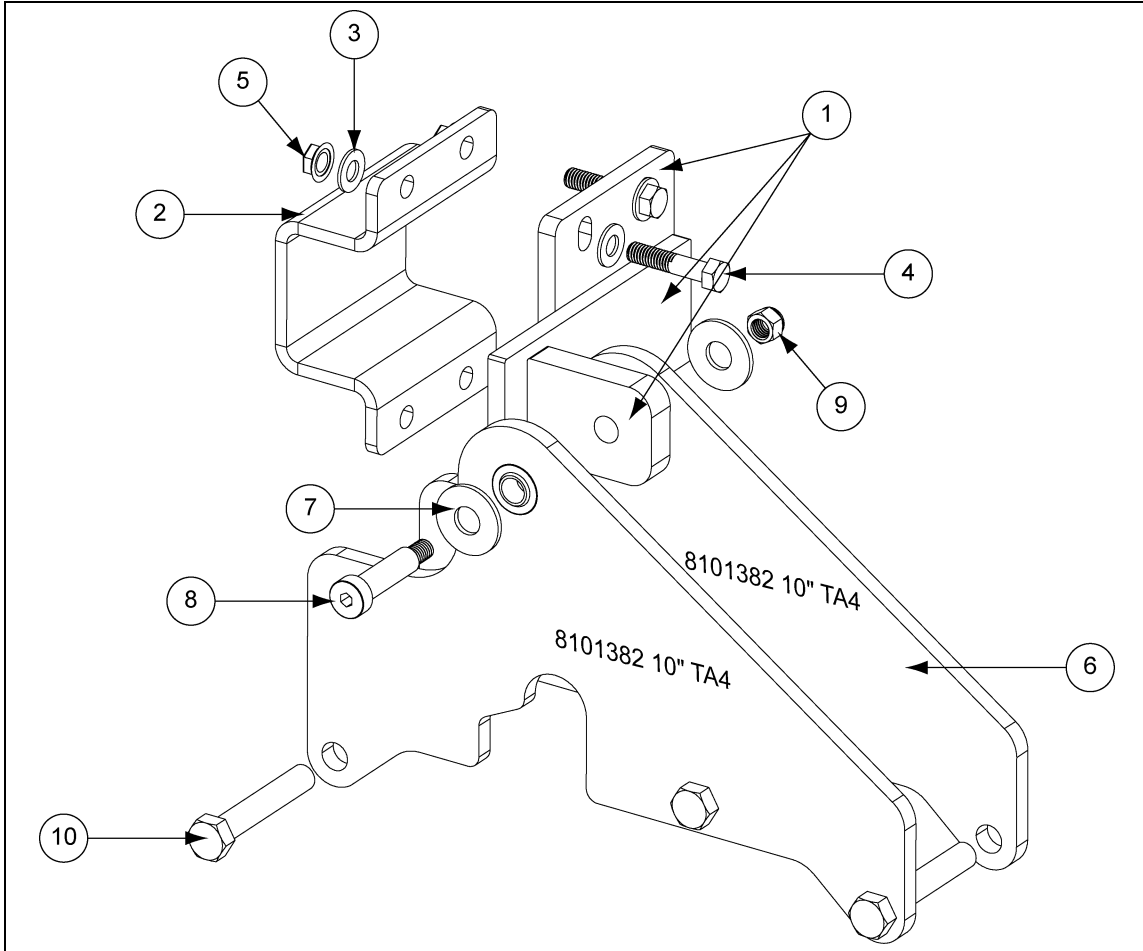

Figure 5

Chain Loop Torque Arm Repair Kit

Chain Loop Torque Arm Repair Kit Parts



Chain Loop Torque Arm Repair Kit Parts List

Ref #	Part #	Description	Qty
1	8101380	Torque Plate Anchor Bracket	1
2	8101346	8" and 10" C-Clamp Bracket	1
2		12" C-Clamp Bracket	1
3	S-7409	Flat Washer 3/8" SAE ZN	8
4	S-8322	Bolt, HHCS 3/8"-16 x 1-3/4" ZN Grade 5	4
5	S-968	Flange Nut 3/8"-16 ZN Grade 5	4
6	8101385	TA3 - 8" and 10" Torque Plate w/ Bearing	2
6	8101383	TA4 - 8" and 10" Torque Plate w/ Bearing	2
6	8101381	TA5 - 10" Torque Plate w/ Bearing	2
6		TA5 - 12" Torque Plate w/ Bearing	2
6		TA6 - 12" Torque Plate w/ Bearing	2
7	S-2121	Flat Washer 1/2" x 1-3/8" x 0.109" Type A ZN	2
8	S-9466	Shoulder Bolt 3/18"-16 x 1/2" x 1-3/4" SKT HD	1
9	S-7383	Nylock Nut 3/8"-16 ZN	1
10	S-7687	TA3 - Bolt, HHCS 3/8"-16 x 2" ZN	3
10	S-8252	TA4 and TA5 - Bolt, HHCS 1/2"-13 x 3" ZN	3