

## 4" and 5" Air System MFT Airlocks

4" - 700 Bu/Hr

5" - 1200 Bu/Hr

5" - 1700 Bu/Hr

Owner's Manual

PNEG-1948

Version: 2.2

Date: **12-21-20**



PNEG-1948

---

**All information, illustrations, photos, and specifications in this manual are based on the latest information available at the time of publication. The right is reserved to make changes at any time without notice.**

## Contents

<b>Chapter 1 Safety</b> .....	<b>5</b>
Safety Guidelines .....	5
Cautionary Symbols Definitions .....	6
Safety Cautions .....	7
Safety Sign-Off Sheet .....	9
<b>Chapter 2 Decals</b> .....	<b>10</b>
<b>Chapter 3 Maintenance</b> .....	<b>13</b>
Maintenance Schedule .....	13
<b>Chapter 4 Air System</b> .....	<b>14</b>
Air System Capacities (Dry Shelled Corn) .....	14
Capacity Chart (4" and 5" Systems) .....	14
<b>Chapter 5 Installation</b> .....	<b>15</b>
Air System Installation Instructions .....	15
Air System Capacities (Dry Shelled Corn) .....	16
Air System Tubing Dimensions .....	17
<b>Chapter 6 Dimensions</b> .....	<b>19</b>
Elbow Angle Measurements .....	19
<b>Chapter 7 Assembly</b> .....	<b>20</b>
Air System Set-Up Procedures .....	20
Air System Control Box Definitions .....	25
Control Overview .....	26
<b>Chapter 8 Overload Chart</b> .....	<b>28</b>
4" and 5" Overload Set Chart .....	28
<b>Chapter 9 Schematic Diagrams</b> .....	<b>29</b>
Schematic - 230V 1 PH - 10 HP Standard .....	29
Schematic - 230V 1 PH - 15 HP Standard .....	30
Schematic - 230V 1 PH - 10 HP Twin .....	31
Schematic - 230V 1 PH - 15 HP Twin .....	32
Schematic - 230V/460V/575V - 3 PH .....	33
<b>Chapter 10 Operation and Management</b> .....	<b>34</b>
Control Box Operational Procedures .....	34
Air System Operation Guidelines .....	35
<b>Chapter 11 Hook-Up Diagrams</b> .....	<b>37</b>

# Table of Contents

---

<b>Chapter 12 Parts List</b> .....	<b>39</b>
Blower Outlet Parts .....	40
4" (700) and 5" (1200) Standard Blower Parts .....	42
4" and 5" Twin Blower Parts .....	44
5" (1700) High-Capacity Blower Parts .....	46
5" (1700) Twin High-Capacity Blower Parts .....	48
4" and 5" Blower Filters .....	51
4" and 5" Airlock Parts .....	52
Airlock Inlet Transition Assembly .....	54
4" and 5" Air Selector Valve .....	56
4" and 5" Deadhead Deflector Assembly for 90° Spout .....	60
4" and 5" Deadhead Deflector Assembly for 60° Spout .....	61
4" and 5" Valve Assembly .....	62
Air System Cyclone Package .....	64
Air System Cyclone Package Small .....	65
Inner Door Assembly - Standard .....	66
Inner Door Assembly - Twin .....	67
Standard Control Panel Assembly 230V - 1 Phase .....	68
Twin Control Panel Assembly 230V - 1 Phase .....	70
Standard Control Panel Assembly 10-40 HP 230V - 3 Phase .....	72
Standard Control Panel Assembly 10-40 HP 460V - 3 Phase .....	74
Standard Control Panel Assembly 10-40 HP 575V - 3 Phase .....	76
<b>Chapter 13 Troubleshooting</b> .....	<b>78</b>
<b>Chapter 14 Couplings</b> .....	<b>80</b>
How to Handle Handling Couplings .....	80
<b>Chapter 15 Warranty</b> .....	<b>81</b>

---

## **Safety Guidelines**

Safety guidelines are general-to-specific safety rules that must be followed at all times. This manual is written to help you understand safe operating procedures and problems that can be encountered by the operator and other personnel when using this equipment. Save these safety guidelines for future reference.

As owner or operator, you are responsible for understanding the requirements, hazards, and precautions that exist and to inform others as required. Unqualified persons must stay out of the work area at all times.

Alterations must not be made to the equipment. Alterations can produce dangerous situations resulting in **SERIOUS INJURY** or **DEATH**.

This equipment must be installed in accordance with the current installation codes and applicable regulations, which must be carefully followed in all cases. Authorities having jurisdiction must be consulted before installations are made.

When necessary, you must consider the installation location relative to electrical, fuel and water utilities.

Personnel operating or working around equipment must read this manual. This manual must be delivered with equipment to its owner. Failure to read this manual and its safety instructions is a misuse of the equipment.

**ST-0001-3**

### Cautionary Symbols Definitions

Cautionary symbols appear in this manual and on product decals. The symbols alert the user of potential safety hazards, prohibited activities and mandatory actions. To help you recognize this information, we use the symbols that are defined below.



This symbol indicates an imminently hazardous situation which, if not avoided, **will result in serious injury or death.**



This symbol indicates a potentially hazardous situation which, if not avoided, **can result in serious injury or death.**



This symbol indicates a potentially hazardous situation which, if not avoided, **can result in minor or moderate injury.**



This symbol is used to address practices not related to personal injury.



This symbol indicates a general hazard.



This symbol indicates a prohibited activity.

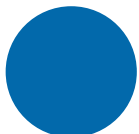

This symbol indicates a mandatory action.

ST-0005-2

## Safety Cautions

### Use Personal Protective Equipment

- Use appropriate personal protective equipment:

**Eye Protection**



**Respiratory Protection**



**Foot Protection**



**Hearing Protection**



**Head Protection**



**Fall Protection**



**Hand Protection**



- Wear clothing appropriate to the job.
- Remove all jewelry.
- Tie long hair up and back.

ST-0004-1

### Follow Safety Instructions

- Carefully read all safety messages in this manual and safety signs on your machine. Keep signs in good condition. Replace missing or damaged safety signs. Be sure new equipment components and repair parts include the current safety signs. Replacement safety signs are available from the manufacturer.
- Learn how to operate the machine and how to use controls properly. Do not let anyone operate without instruction.
- If you do not understand any part of this manual or need assistance, contact your dealer.



ST-0002-1

## 1. Safety

### Sharp Edge Hazard

- This product has sharp edges, which can cause serious injury.
- To avoid injury, handle sharp edges with caution and always use proper protective clothing and equipment.



ST-0036-2

### Stay Clear of Moving Parts and Air Valves

- Entanglement in rotating sprocket or moving chain will cause serious injury or death. Wear close fitting clothing.
- Keep all shields and covers in place at all times.
- Lock-out power source before making adjustments, cleaning, or maintaining equipment.
- Stay clear of air blast from valve. Always wear safety glasses to protect your eyes from flying debris.



ST-0048-1

### Install and Operate Electrical Equipment Properly

- Electrical controls must be installed by a qualified electrician and must meet the standards set by applicable local codes (National Electrical Code for the US, Canadian Electric Code, or EN60204 along with applicable European Directives for Europe).
- Lock-out power source before making adjustments, cleaning, or maintaining equipment.
- Make sure all equipment is properly grounded.



ST-0027-4

### Maintain Equipment and Work Area

- Understand service procedures before doing work. Keep area clean and dry.
- Never service equipment while it is operating. Keep hands, feet, and clothing away from moving parts
- Keep your equipment in proper working condition. Replace worn or broken parts immediately.



ST-0003-1





## 2. Decals

Install safety decals on components as shown in this section. Always ensure that safety decals are in a place, easily readable and in good condition. If a decal cannot be easily read for any reason or has been painted over, replace it immediately. Contact your dealer or the manufacturer to order a replacement decal free of charge.

For decal replacements contact GSI at:

### GSI Decals

1004 E. Illinois St.  
Assumption, IL. 62510  
Phone: 1-217-226-4421

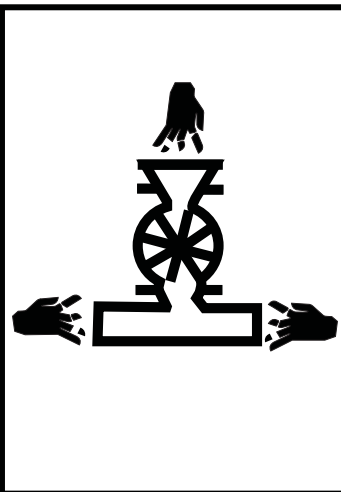
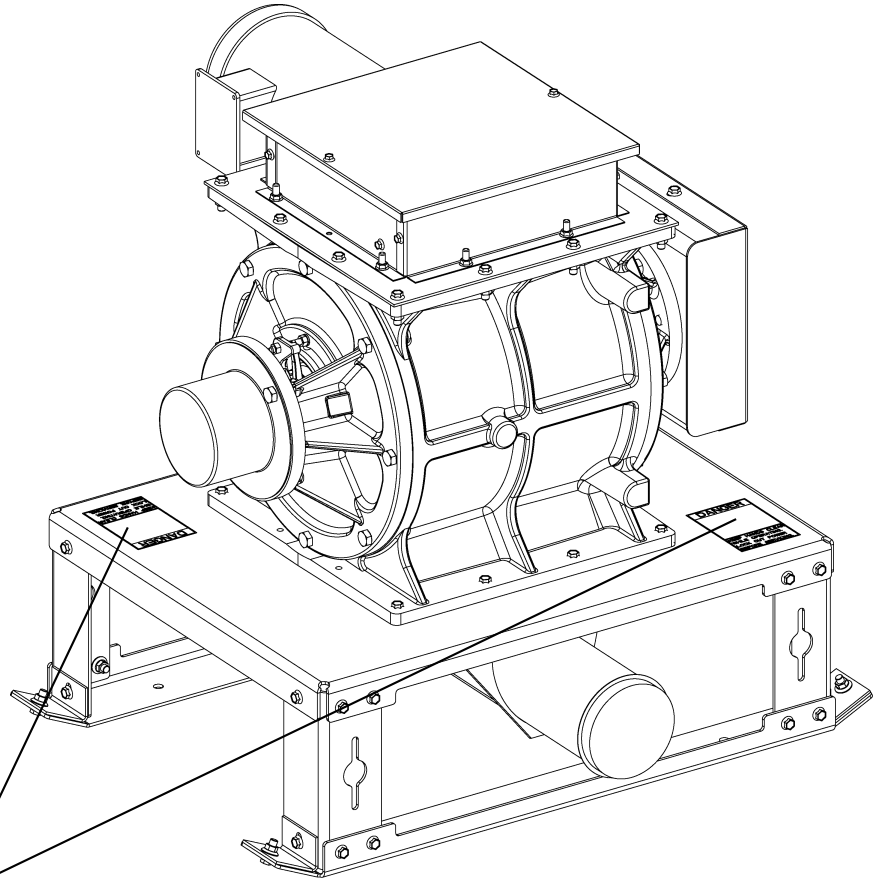

**! DANGER**

**Keep hands clear  
while operating.**

**Lock out power  
before servicing.**

N10080

N10080



GSI Group 217-226-4421



**DANGER**

**SHEAR POINT**  
Moving parts can  
crush and cut. Keep  
hands clear of  
sprocket and chain.

DC-1382

DC-1382

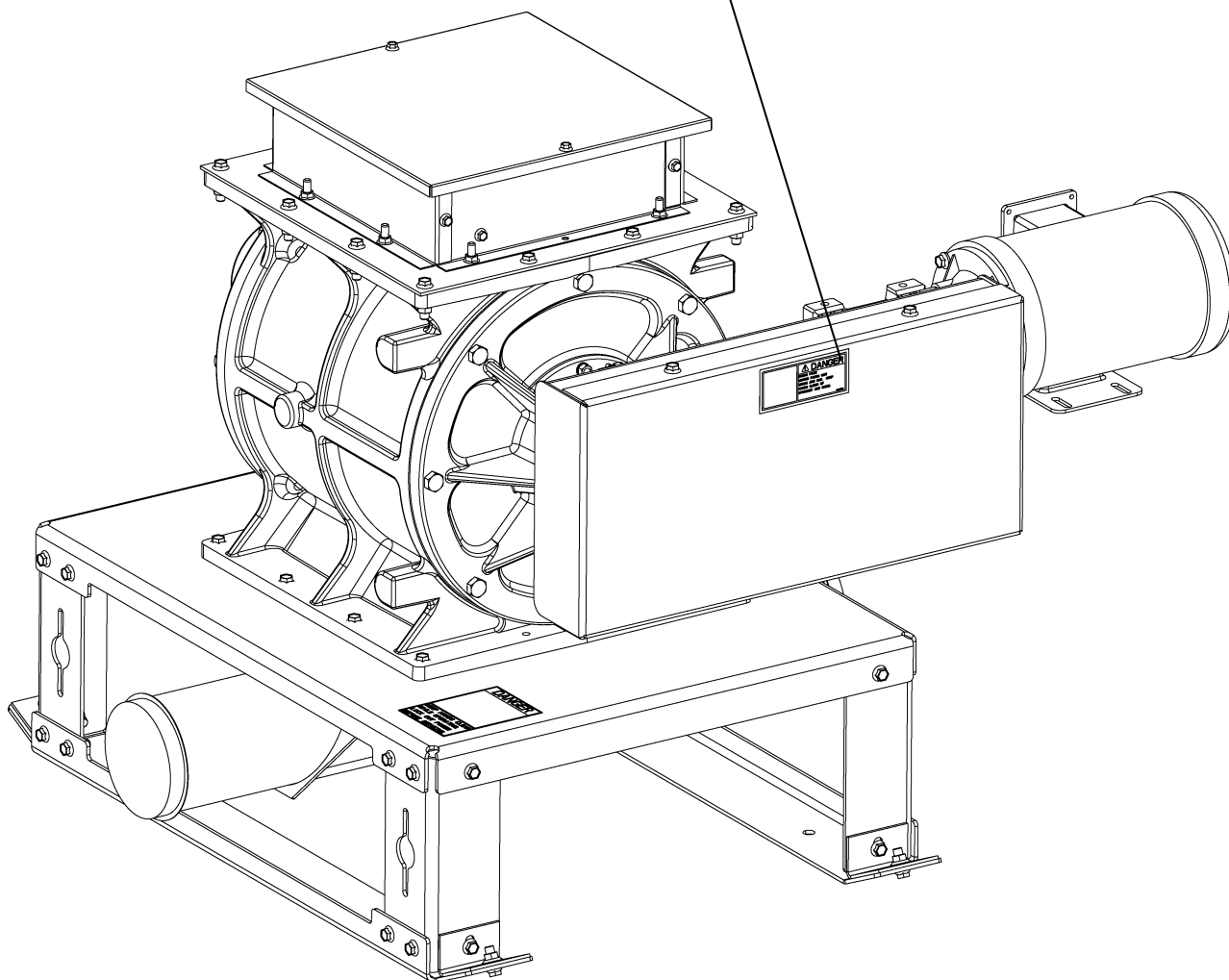



301L0003

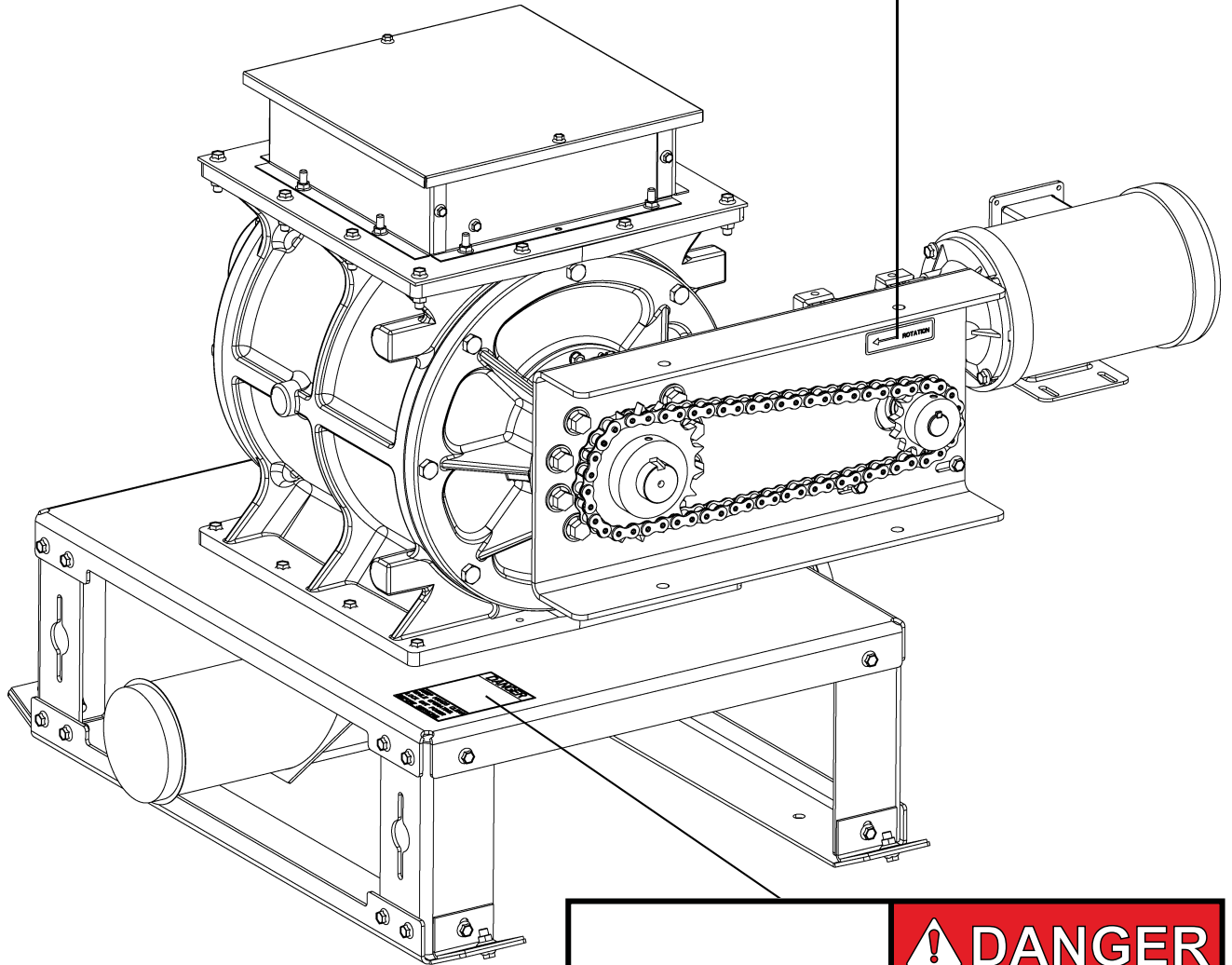

	<b>⚠ DANGER</b>
	<p>Keep hands clear while operating.</p> <p>Lock out power before servicing.</p>

N10080

N10080

## Maintenance Schedule

<b>Initial Start-Up</b>	
1. GD Dura Flow	1. Oil level with middle of sight glass (AS-0886 or AS-0887 synthetic oil).
2. GD Dura Bar	2. Oil level with center of oil level gauge/sight glass.
3. Airlock Gearbox	3. Gearbox is sealed.
4. Air Filter	4. Installed properly.
5. Chain	5. Tensioned and aligned.
6. Tubing System	6. All couplers tight. All tubing connections have good fit. Tubing laid out straight. Elbows fitting properly.
<b>After First 10 Hours and Daily</b>	
1. Air Filter	1. Check for excessive dust build-up.
2. Tubing	2. Check all connections for leaks and signs of separating.
<b>Weekly</b>	
1. Chain	1. Oil
2. Blowers and Gearbox	2. Check oil levels.
<b>1500 Hours (Synthetic Oil) - 500 Hours (Standard Oil)</b>	
1. GD Dura Flow	1. Drain oil and replace with 1.5 Qts. of AS-0886 synthetic oil. (Fill to middle of sight glass.)
2. GD Dura Bar	2. Replace with 1.5 Qts. of part #AS-0886. Add oil to both ends of blower. (Fill to middle of both sight glasses.)
<b>Extended Shut Down</b>	
Disconnect Main Power Unit.	
1. Blower	1. Remove inlet assembly and spray oil on lobes while rotating by hand, to prevent rust. Keep hands and objects out of blower. Re-install inlet assembly.
2. Airlock	2. Coat interior with oil, while rotating by hand, to prevent rust. Re-install weather cover.
3. Chain	3. Oil chain to prevent rust.

## 4. Air System

### Air System Capacities (Dry Shelled Corn)

Effective Length (Feet)	700 Bu/Hr 4" System (Dura Bar)			1200 Bu/Hr 5" System (Dura Bar)		1700 Bu/Hr 5" System (Dura Flow)		
	10 HP Motor	15 HP Motor	20 HP Motor	20 HP Motor	30 HP Motor	20 HP Motor	30 HP Motor	40 HP Motor
50	525	800	850	1100	1300	1200	1600	1800
100	500	775	825	1075	1275	1175	1575	1775
150	475	750	800	1050	1250	1150	1550	1750
200	450	700	750	1000	1200	1100	1500	1700
250	400	650	700	925	1125	1025	1400	1600
300	350	575	625	825	1025	925	1275	1450
350	275	475	525	700	900	800	1100	1275
400	200	350	400	550	750	650	900	1050
450	-	-	225	350	550	450	650	775
500	-	-	-	-	-	-	-	400

Effective tube length is determined by adding the horizontal length, twice the vertical height and 10' for every elbow of 45° or greater. Add 5' for each elbow less than 45°. Use the horizontal run and add the vertical rise of inclined systems to calculate the effective length.

### Capacity Chart (4" and 5" Systems)

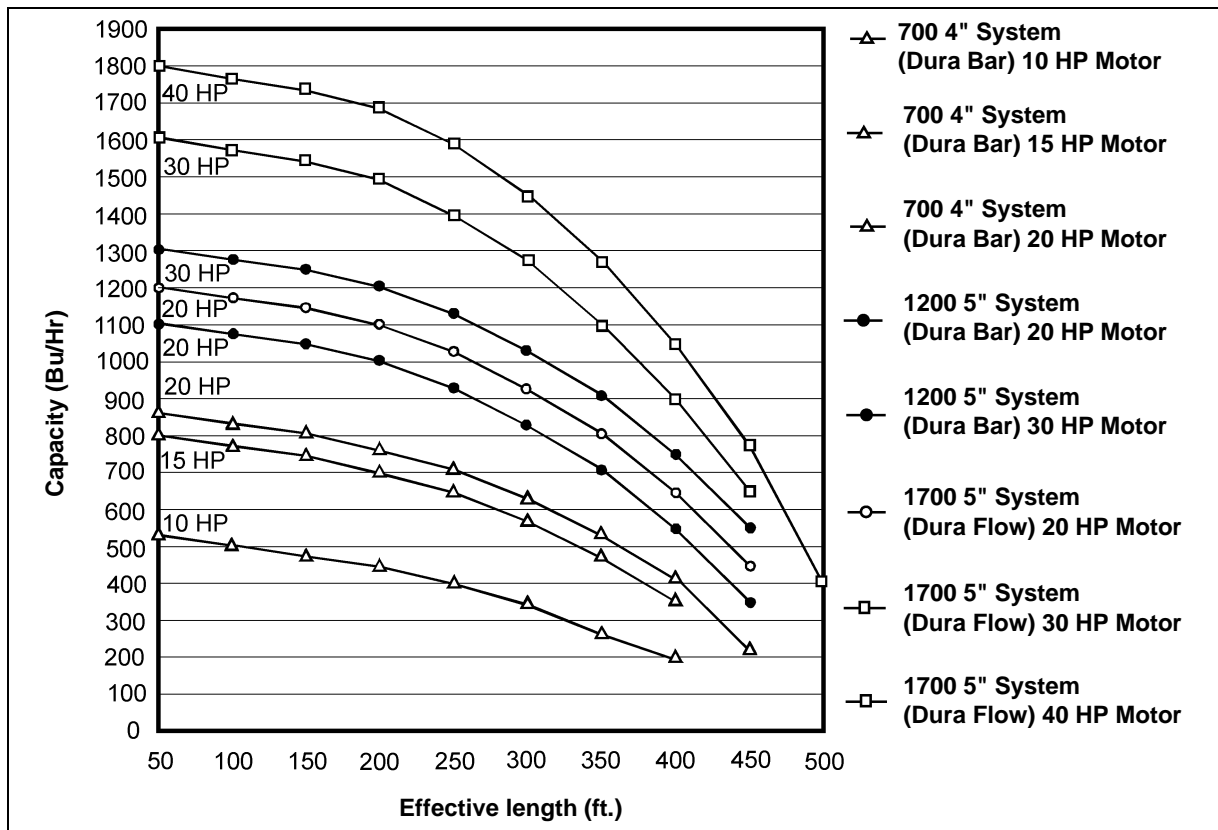

Figure 4A

## Air System Installation Instructions

1. Determine the most convenient location for the airlock and blower. Take into consideration the direction of the prevailing winds. It is important to locate the blower in as clean an environment as possible. This greatly reduces the maintenance requirements on the air filter system. When the distance between the airlock and blower is over 10', it is best to use galvanized pipe with short flex hose on the ends to couple the units together to keep airflow restrictions to a minimum.
2. The noise level of the blower unit can be reduced by placing the unit behind a wall, barrier or in a small building. If this is done, make sure that the building has adequate ventilation for both air intake and cooling of the blower and motor.
3. The grain discharge chute on the airlock is assembled at the factory so that grain movement is at 90° to the length of the skid. This orientation can be changed by removing the mounting hardware at the base of the airlock and rotating the discharge chute to the preferred direction. Be sure to use silicone to seal the discharge to the skid. Note that the airlock itself is sealed to the skid surface and does not need to be moved to redirect the discharge chute.

**NOTE:** *A minimum of 10' is needed between the airlock discharge and the first elbow in the system.*

4. Determine the best routing of the galvanized steel pipe from the airlock to the storage areas. Use galvanized elbows for changing the grain direction. This will give better performance and longer life than flex hose.
5. Bolt the tube mounting brackets to the desired location using at least two (2) mounting brackets on the vertical wall and two (2) on the roof of the grain bin. The mounting brackets can be formed to match existing hole patterns in the bin.
6. Determine the number and degree of arc required in the elbows. The 90° and 60° elbows are standard - different lengths of arc can be cut from these standard elbows. [\(See Page 19.\)](#)

**NOTE:** *A minimum of 8' between elbows is required for proper operation.*

7. Cut the steel tubing to the required length and fasten it together with compression couplings. The ends must be cut square to fit properly. Make sure that the stainless steel gasket protecting sleeve is placed over the joint before tightening the coupler. Tighten the three (3) bolts on the coupler evenly or until the coupler flanges butt together. [\(See Page 80.\)](#)
8. The steel tubing can be laid underground, on top of the ground or placed on blocks. If placed on blocks, the tubing must be supported every 15'. If placed underground, the tube should enter and exit the ground at a 45° angle and be coated with a protective tar to prevent corrosion.
9. Measure the distance between the airlock and blower. Use flex hose or a combination of flex hose and galvanized tubing to connect the units together. Note that the grain discharge chute on the airlock is tapered and that grain can discharge in either direction.
10. Install all tubing required to transfer grain to the storage areas.
11. To attach the deadhead deflector to the tubing, simply slide the deadhead deflector onto the tubing and tighten the clamp provided. Flexible galvanized tubing can be attached to the deadhead down spout if needed. If a cyclone is used, an elbow and mounting brackets are needed.

## 5. Installation

12. Select a location to mount the electrical control box that is accessible and easily reached should shut down of unit be necessary. It should be close enough to the blower to run the 30' of rubber pressure hose between the blower and the control box. Otherwise, a longer length of hose must be ordered.
13. Before wiring or operating the Air System unit, read the control box description [on Pages 25-27](#) to understand the operation of the Air System control box. If the control box is to be wired to remote equipment, review the wiring diagrams [on Pages 29-33](#) for proper hook-up.

### Air System Capacities (Dry Shelled Corn)

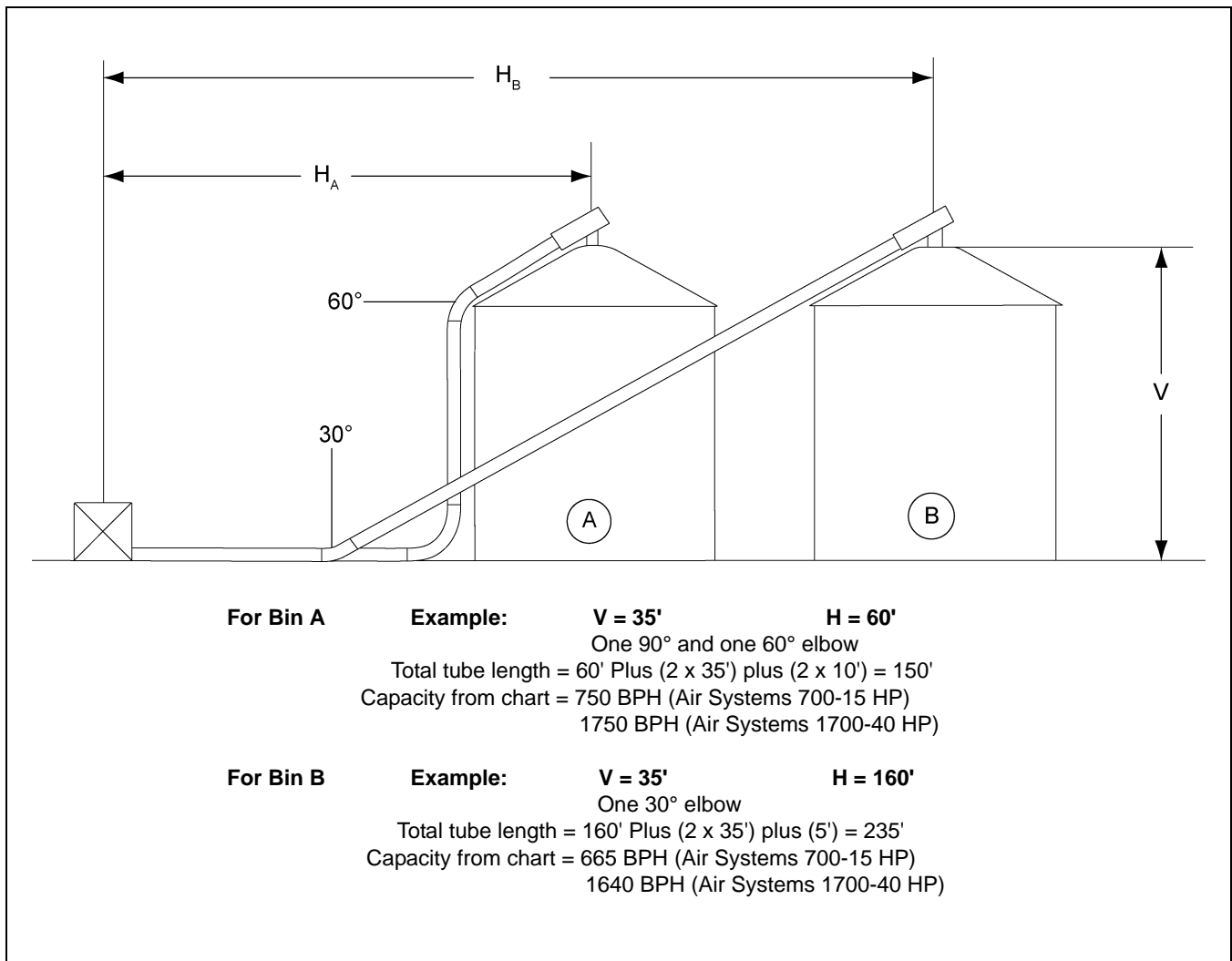

Figure 5A



## Air System Tubing Dimensions

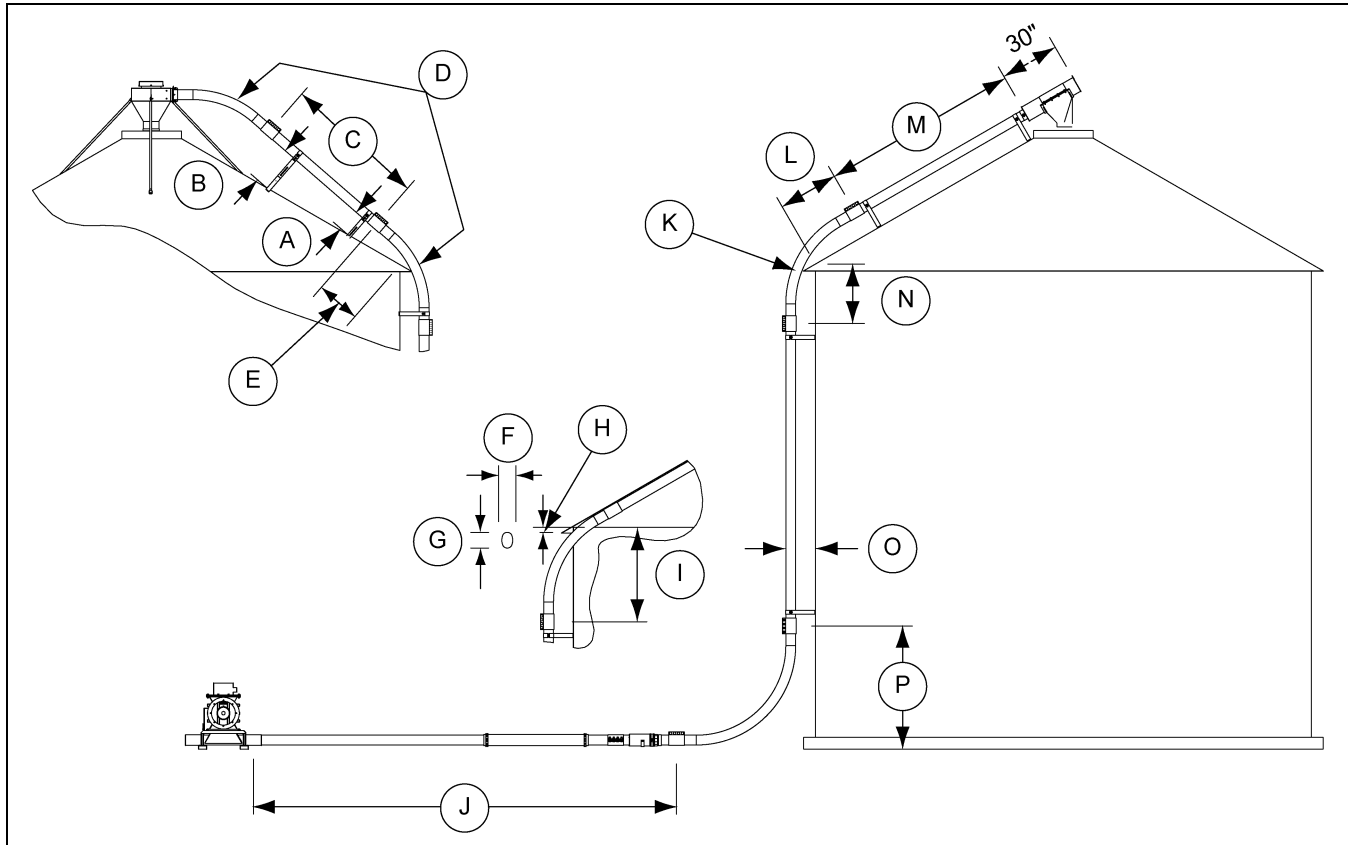

Figure 5B

Ref #	Description
A	12" Minimum
B	21" Maximum
C	Cut to Fit
D	Cut one full 90° elbow to make both pieces.
E	Not the same as "B" dimension.
F	Width equals tube diameter.
G	6" for 4", 7-1/2" for 5", 9" for 6"
H	"D" Dimension (See Page 18.)
I	"C" Dimension (See Page 18.)
J	10' Minimum distance to first elbow.
K	Use a standard 60° elbow with straight tangents on both ends for 30° roofs.
L	"B" Dimension (See Page 18.)
M	"E" Dimension (See Page 18.)
N	"A" Dimension (See Page 18.)
O	10" Standard Bracket
P	58" for 4", 60-1/2" for 5", 61" for 6"

Cut a standard 90° elbow to fit roof angles other than 30°. Position the cut end on the roof.

## 5. Installation

### Air System Tubing Dimensions (Continued)

System Size	Roof Angle	Reference Dimension													
		A	B	C	D	E *									
						18' Diameter	21' Diameter	24' Diameter	27' Diameter	30' Diameter	33' Diameter	36' Diameter	42' Diameter	48' Diameter	
4"	25	31"	23"	47-1/2"	5-3/4"	7' 1"	8' 9"	10' 5"	12' 1"	13' 9"	15' 5"	17' 1"	20' 5"	23' 9"	
	30	29"	29"	46"	3-1/2"	7' 1"	8' 9"	10' 5"	12' 1"	13' 9"	15' 5"	17' 1"	20' 5"	23' 9"	
	35	27"	19"	45"	2-1/2"	8' 6"	10' 2"	11' 10"	13' 6"	15' 2"	16' 10"	18' 6"	21' 10"	25' 2"	
5"	25	32-1/2"	22-1/2"	50"	4-1/2"	7'	8' 9"	10' 6"	12' 3"	14'	15' 9"	17' 6"	21'	24' 6"	
	30	30-1/2"	30-1/2"	49"	3-1/4"	6' 10"	8' 7"	10' 4"	12' 1"	13' 10"	15' 7"	17' 4"	20' 10"	24' 4"	
	35	28-1/2"	18-1/2"	48"	2-1/4"	8' 6"	10' 3"	12'	13' 9"	15' 6"	17' 3"	19'	22' 6"	26'	
6"	25	32-1/4"	22-1/4"	51"	4-1/2"	7' 3"	9' 1"	10' 11"	12' 9"	14' 7"	16' 5"	18' 3"	21' 11"	25' 7"	
	30	30-1/4"	30"	50"	3"	7' 1"	8' 11"	10' 9"	12' 7"	14' 5"	16' 3"	18' 1"	21' 9"	25' 5"	
	35	28-1/4"	18"	49"	2"	8' 8"	10' 6"	12' 4"	14' 2"	16'	17' 10"	19' 9"	22' 4"	27'	

\* **NOTE:** Add 10" to "E" dimension if roof elbow has been cut from a 90° elbow.

# Elbow Angle Measurements

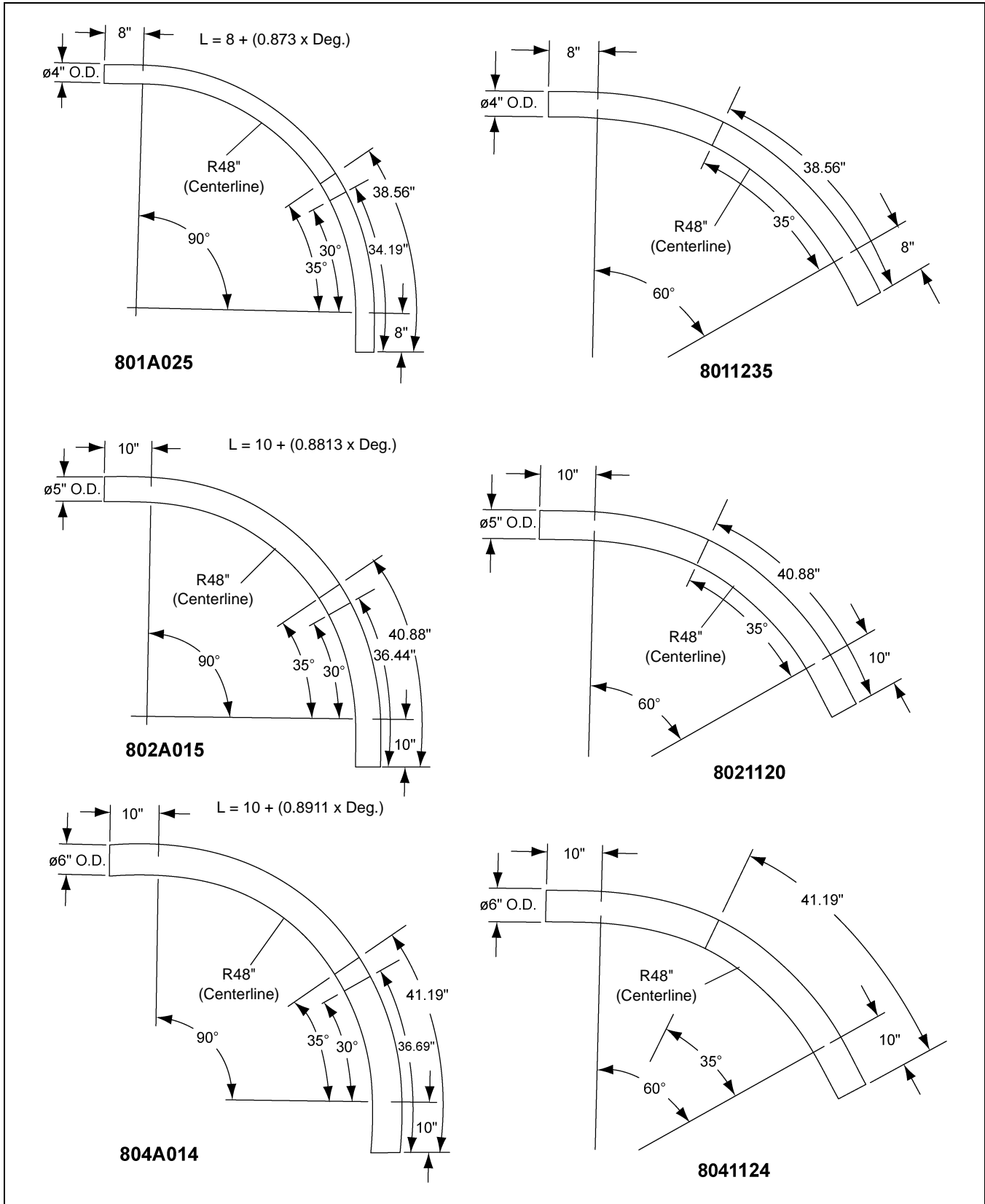

Figure 6A

### Air System Set-Up Procedures

1. The air filter extension tube and housing are connected to the blower inlet by a compression coupler. For extended filter life, if the pneumatic system is being operated in extremely dirty conditions, a longer extension tube can be used between the blower inlet and the air filter. BE SURE the air filter is positioned so that routine inspection and service can be performed.
2. Place the air filter element with pre-filter on the base and cover with the filter canister using the 3/8" wing nut and washer. The wing nut does not need to be more than finger tight. (See [Figure 7A](#), [Figure 7B](#) and [Figure 7C](#).)

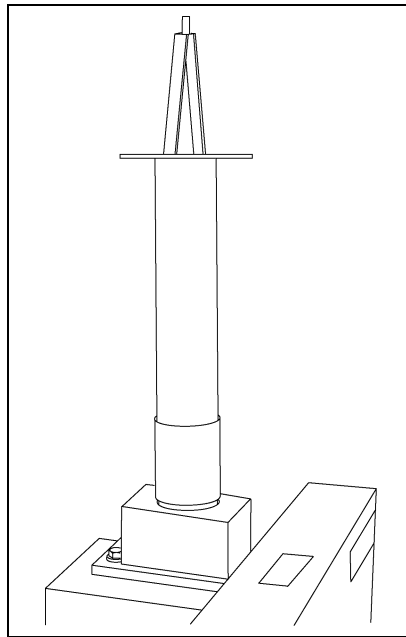

Figure 7A

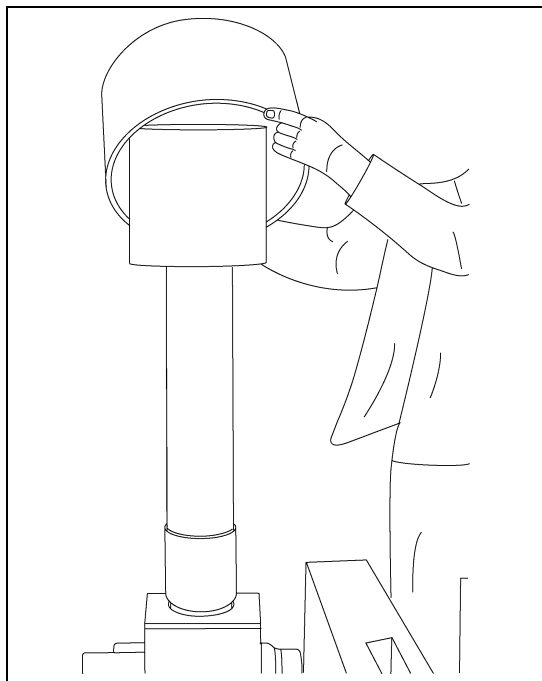

Figure 7B

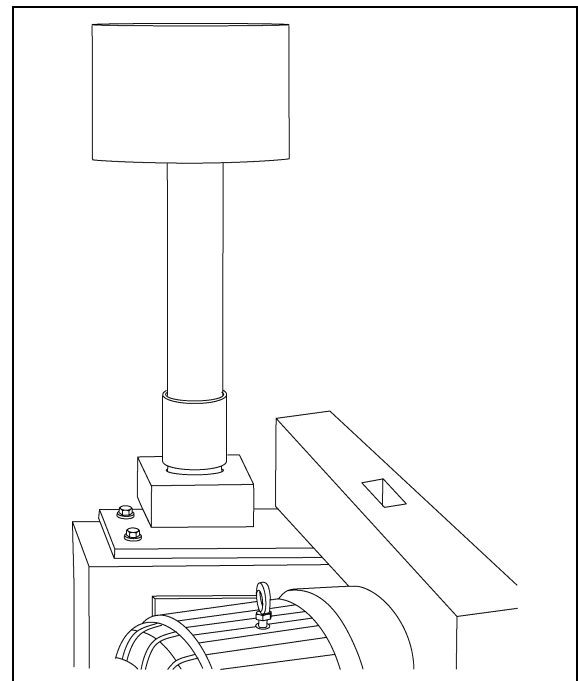
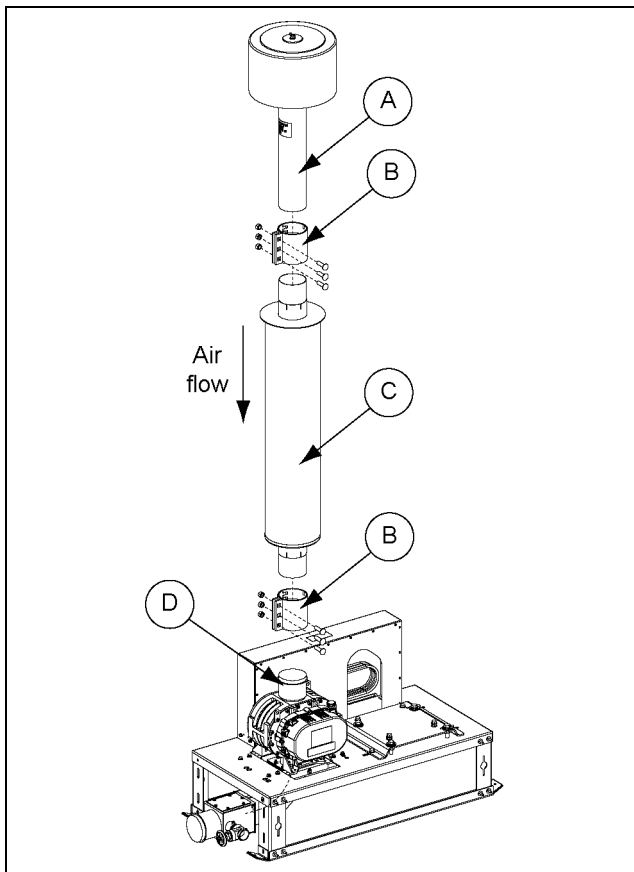

Figure 7C

**IMPORTANT:** A silencer (C) assembly may be optional with the air system set-up. If available and to be assembled, follow [Step 3](#) and [Step 4](#).  
If the silencer (C) assembly is not available, skip step (3 and 4) and continue from [Step 5 on Page 22](#).

3. Install the lower end of the silencer (C) along with the coupler (B) to the blower inlet (D). Fasten all together by tightening the bolts of the coupler.
4. Install the upper end of the silencer (C) along with the coupler (B) to the pre-filter. Fasten all together by tightening the bolts of the coupler.



**Figure 7D**

Ref #	Description
A	Pre-filter
B	Coupler (802A017)
C	Silencer (802B009-W)
D	Blower Inlet (8011246)

**NOTE:** In horizontal applications, the silencer (C) will be installed to the blower outlet as shown in [Figure 7E](#).

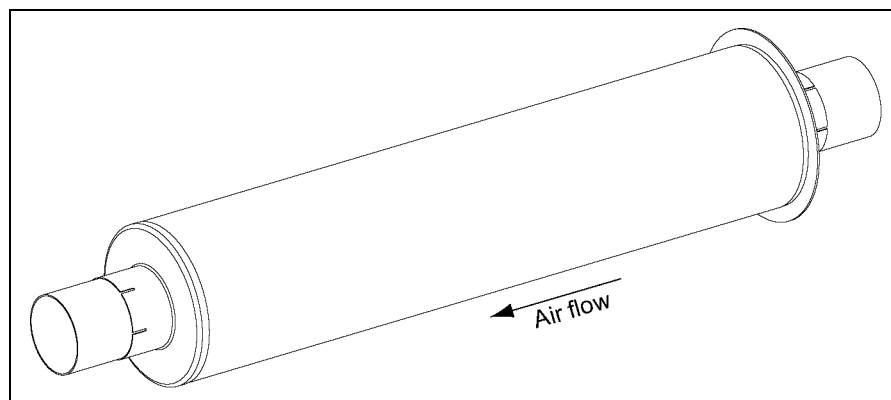

**Figure 7E**

## 7. Assembly

5. Check the motor nameplate for the correct motor frame size. Remove the hardware shipped in the motor mounting plate. Locate the motor on the mounting plate using the hole pattern, which aligns with the motor base. Bolt the motor securely to the mounting plate with the supplied hardware that was previously removed. Loosen the four (4) 1/2" flange head bolts, which secure the motor mounting plate to the blower base. (See Figure 7F.)

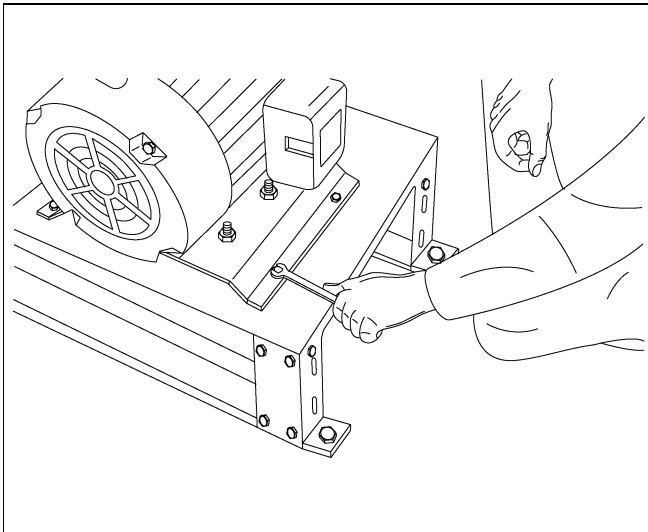

Figure 7F

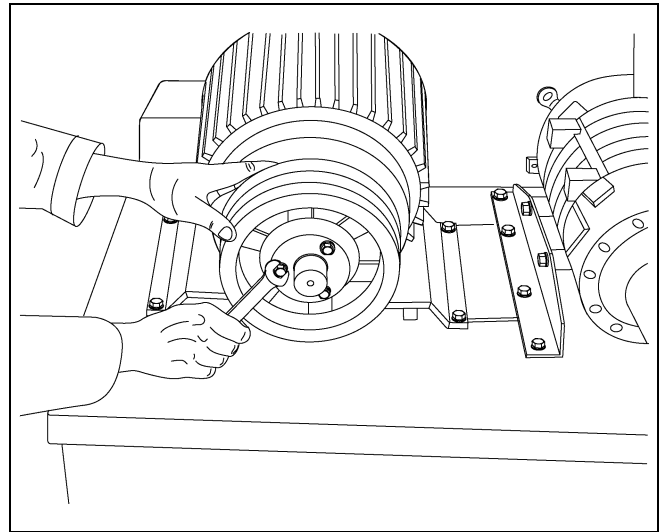

Figure 7G

6. Place the specified pulley onto the motor and align it with the blower pulley. (See Figure 7G.)
7. Place the matching set of V-belts on the pulleys. Tighten the belts by evenly turning the cap screws clockwise. Belts should have 3/8" deflection at 10 pounds pressure per belt. (See Figure 7H and Figure 7I.)

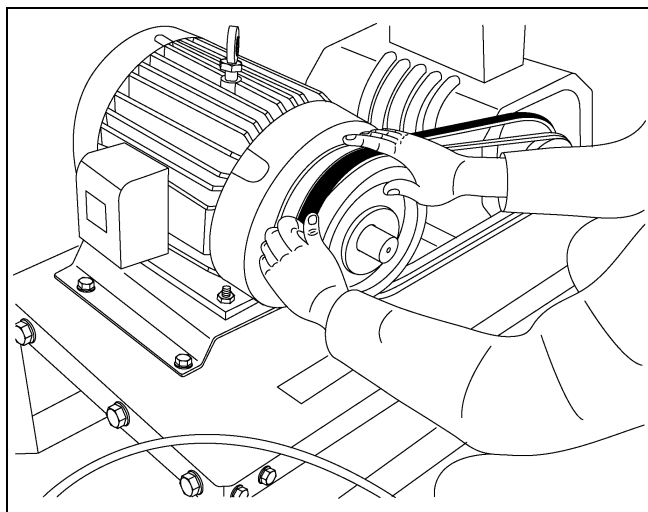

Figure 7H

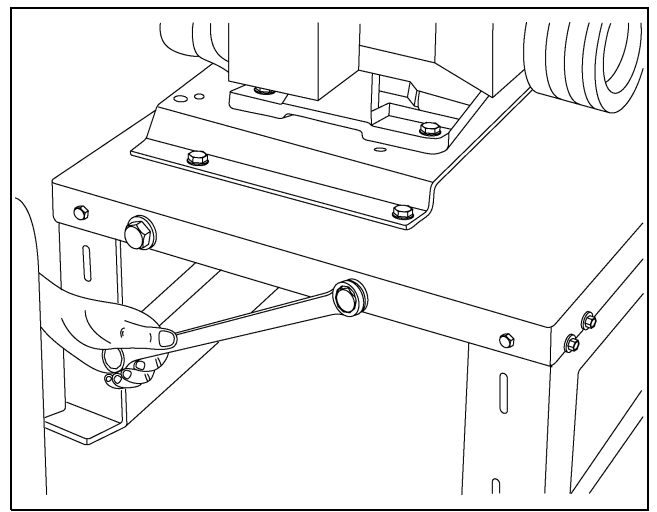

Figure 7I



**Too much tension on belts will cause blower damage.**

8. Keeping the motor in proper alignment is necessary and can be accomplished by using an open end wrench to turn the nut on the take-up bolt closest to the rear of the motor. This nut is located behind the flange of the blower base. Adjust if necessary. Tighten the four (4) flange head bolts that secure the motor mounting plate to the blower base. Re-install drive shield. (See Figure 7J.)

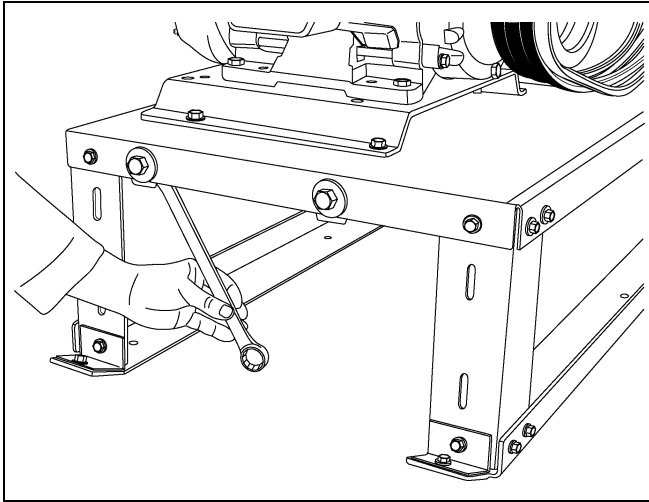

Figure 7J

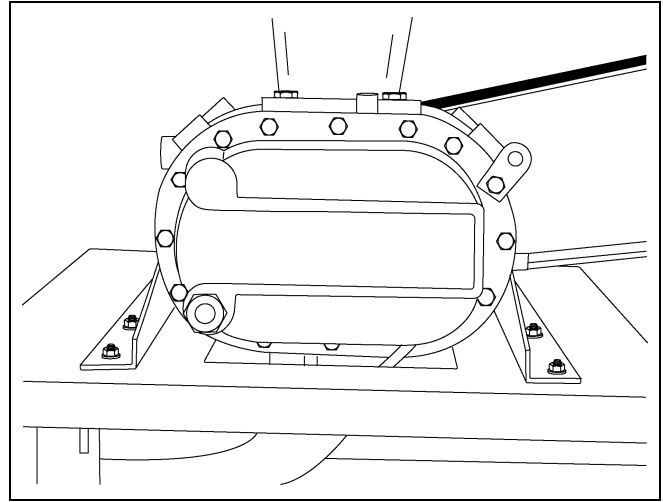

Figure 7K



**Rotate the motor by hand and listen for any rubbing or knocking by either the motor or the blower. When the motor is wired, it must be checked for CCW rotation.**

9. The oil level should be at the center of the sight glass on the blower. Add part # AS-0886 if required. DO NOT operate blower until correct oil level is indicated. The 4" roots blower has sight glasses on both ends. Be sure oil levels are indicated on both sight glasses. (See Figure 7K.)
10. Using four (4) 5/16" x 3/4" flange head bolts, mount the motor to the airlock gearbox. Place the specified sprocket on to the airlock shaft and align to sprocket on gearbox. (See Figure 7L.)

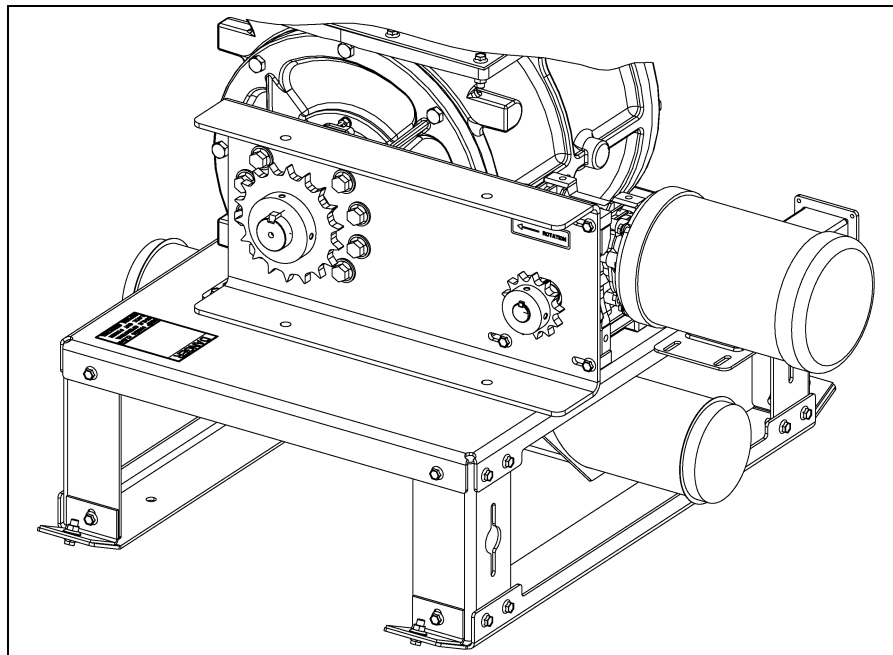

Figure 7L

## 7. Assembly

- Next, install the chain on to the sprockets and apply tension by sliding the gearbox to the right. (See [Figure 7M.](#)) Tighten the four (4) 3/8" flange bolts on the two (2) drive mount bars.

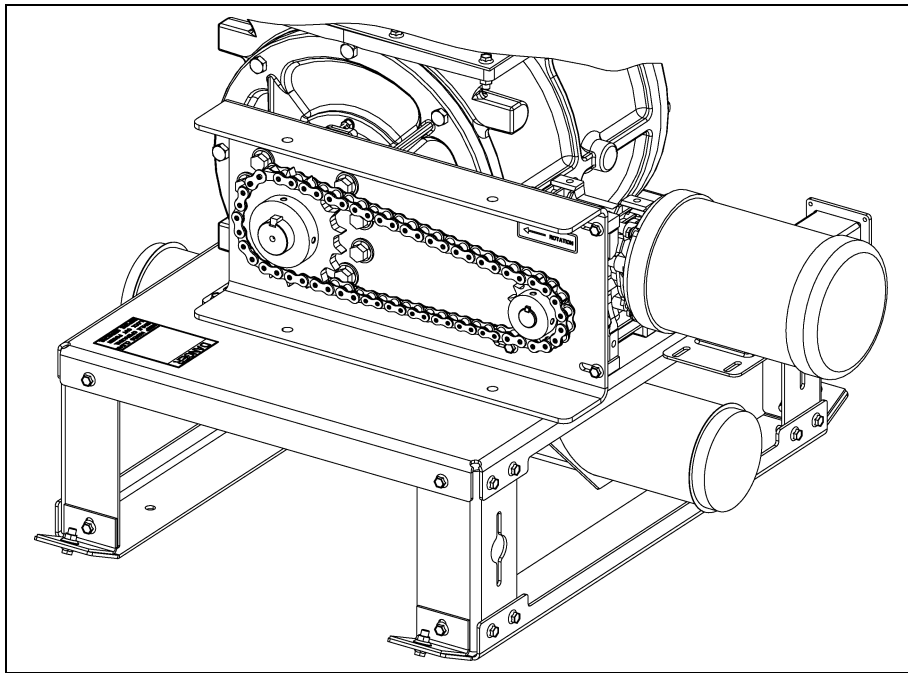

Figure 7M

- Remove 1/4" pipe plug in gate valve pipe. Install gauge assembly and attach air hose. (See [Figure 7N.](#))

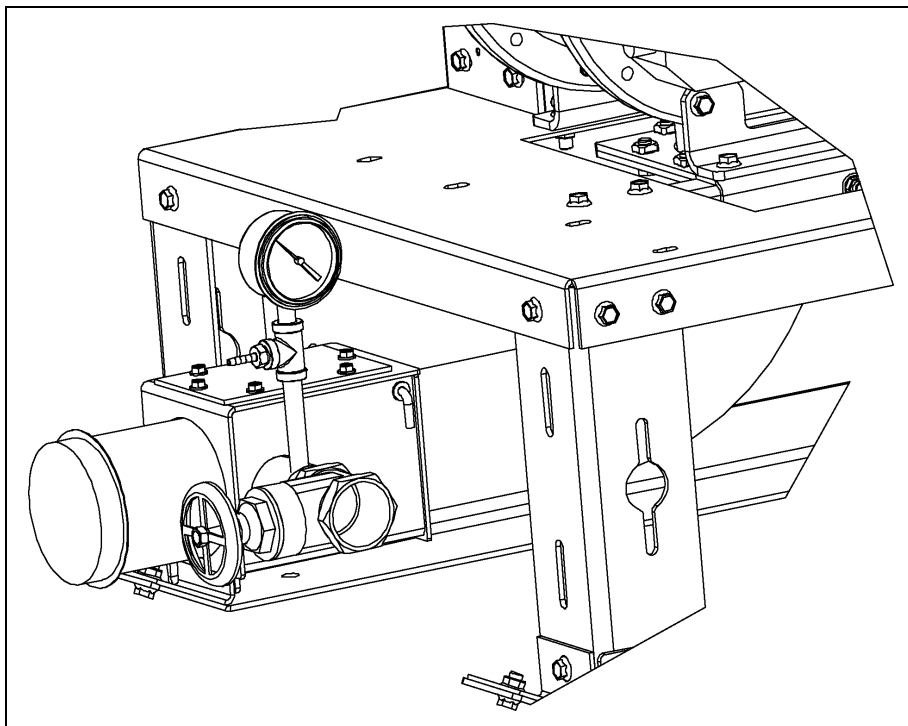

Figure 7N

**THE SET-UP OF THE PNEUMATIC AIR SYSTEM IS NOW COMPLETE.**



# Air System Control Box Definitions

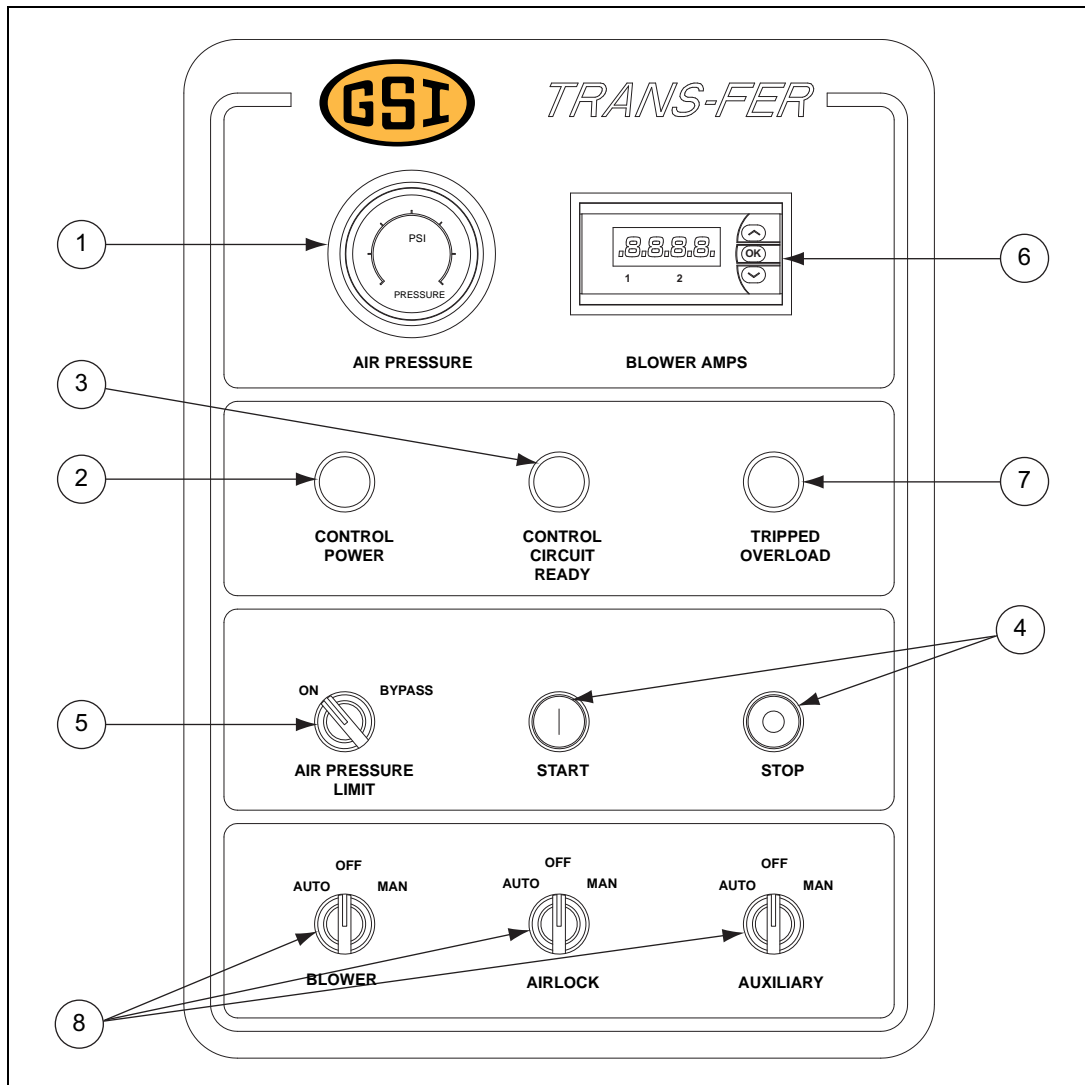

Figure 70

Ref #	Description
1	Air Pressure Gauge
2	Power "ON" Indicator Light
3	Control Circuit Ready Indicator Light
4	Start/Stop Switch
5	Air Pressure Limit
6	Digital Amp Meter
7	Tripped Overload Indicator Light
8	Control Switches

### Control Overview

The redesigned control box for air systems now incorporates short circuit protection for each motor branch circuit. This is provided with circuit breakers which are the same as used in the portable dryers. In addition, the contactors and overloads are now IEC style controls (portable dryer parts also). This removes the need for separate thermal heater strips for the overloads. Be aware that the power connections to the new style box are different. The incoming power still enters at the lower right bottom of the box. The output power for the motors and remote control connections now exit the bottom of the box.



**Confirm that the overloads are set to the values shown on the “Overload Set Chart” on Page 28 before operating the system.**

The remaining operations are the same as the previous control box design.

1. **Air Pressure Gauge:** This gauge indicates the system air pressure.
2. **Power “ON” Indicator Light:** This lamp will illuminate when power is supplied to the control box.
3. **Control Circuit Ready Indicator Light:** This lamp will illuminate when the Start button has been pushed and all control circuits are completed. When lit and in the automatic mode, the air system will run whenever it receives a signal to start.
4. **Start/Stop Switch:** The Start button must be pushed before any part of the Air System can be run. Pushing the Stop button will immediately stop all functions.
5. **Air Pressure Limit Control Switch:** When in the “ON” position, this switch will allow the air pressure switch to immediately shut down the air system whenever the air pressure exceeds preset conditions.
6. **Amp Meter:** The amp meter measures the current flow to the blower motor.
7. **Tripped Overload Indicator Light:** This lamp will illuminate when any of the motor thermal overloads in the control box has tripped. The overloads for all three (3) circuits (aux, airlock and blower) must have thermal overloads installed to operate the system. See thermal unit chart [on Page 28](#).
8. **Control Switches:** The operation of the blower, airlock and auxiliary equipment of the air system is controlled by placing these switches in the “AUTO”, “MANUAL” or “OFF” position.
9. **Automatic Control Terminals:** When the air system is ready to run (i.e., the control ready light is ON), the system can then be started and run by completing the circuit between terminals 1 and 2. The blower, airlock or auxiliary equipment will not run in the automatic mode unless terminals 1 and 2 are connected. For example, a closing set of contacts in a dryer control box would complete the circuit between terminals 1 and 2 and automatically start the air system. ([See Figure 7P on Page 27.](#))



**No voltage should be supplied to terminals 1 and 2. See the diagrams on Pages 29-33.**

10. **Remote Shut Down Control:** A remote piece of equipment can be caused to shut down with the air system by putting terminals 3 and 4 in series with the control circuit of the remote equipment. This circuit has a maximum current rating of 10 amps. The circuit between terminals 3 and 4 is closed whenever the control circuit ready light is ON, regardless of the position of the control switches (“AUTO”, “OFF” or “ON”). See the diagram on [Page 29](#) and [Page 38](#).

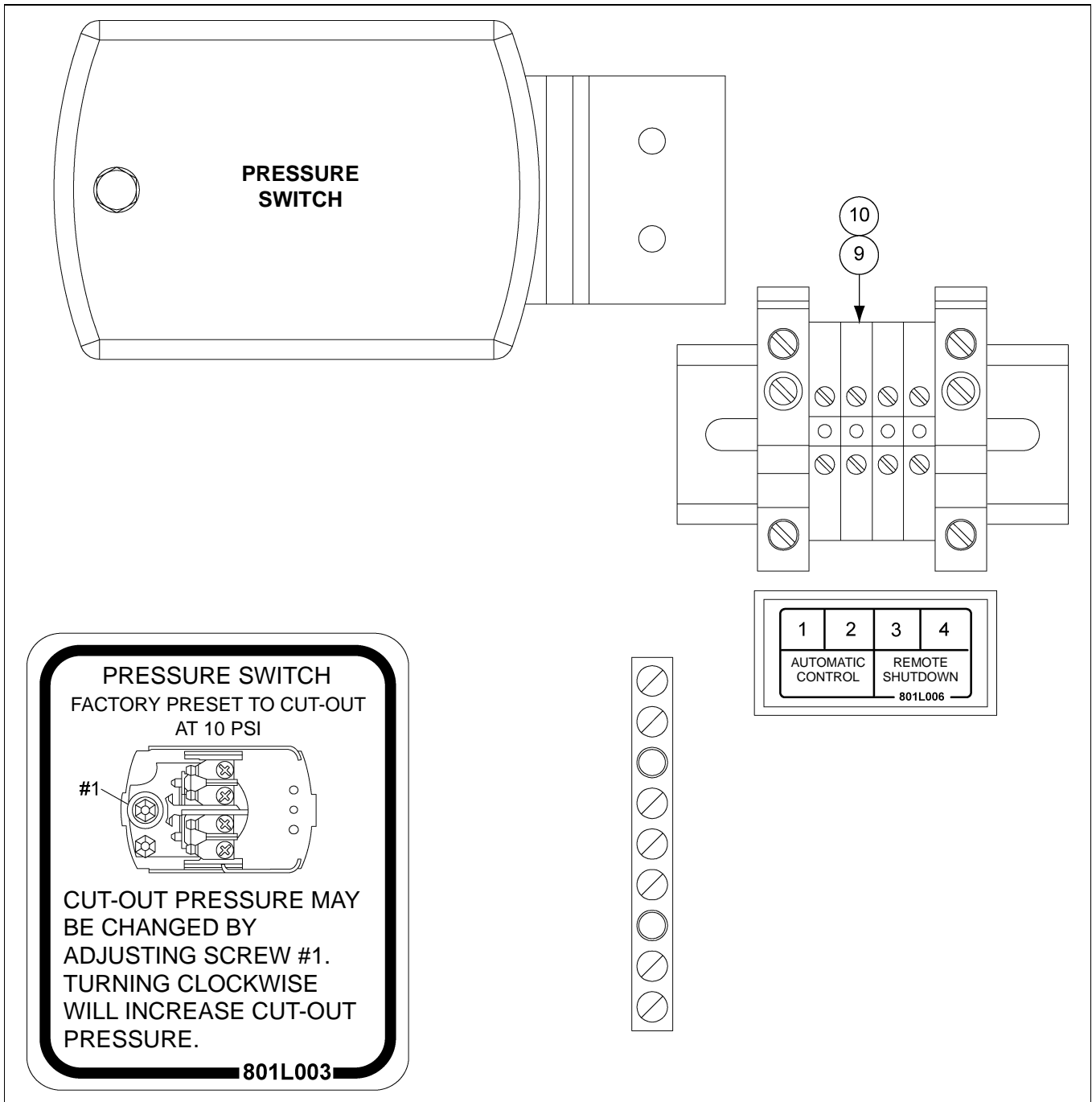

Figure 7P Auto Remote

Ref #	Description
9 and 10	Automatic Control Terminals and Remote Shut Down Control

## 8. Overload Chart

### 4" and 5" Overload Set Chart

Single Motor	C-8693 Airlock O/L Relay 5.5-8 Amps	C-8694 Auxiliary O/L Relay 7-10 Amps	CH-1052 Airlock O/L Relay 2.5-4 Amps	CH-1053 Auxiliary O/L Relay 4-6 Amps	056-1945-7 Airlock O/L Relay 1.6-2.5 Amps	056-1945-7 Auxiliary O/L Relay 1.6-2.5 Amps	AS-0777 Blower O/L Relay 9-13 Amps	056-1944-0 Blower O/L Relay 12-18 Amps	056-1943-2 Blower O/L Relay 17-25 Amps	056-2079-4 Blower O/L Relay 25-32 Amps	AS-0752 Blower O/L Relay 37-50 Amps	D03-0984 Blower O/L Relay 48-65 Amps	AS-0757 Blower O/L Relay 48-65 Amps	CH-1062 Blower O/L Relay 63-80 Amps	056-2276-6 Blower O/L Relay 90-150 Amps
AS-0669 Control Package - 10 HP 230V - 1 PH	6.4	8.0									38				
AS-0674 Control Package - 10 HP 230V - 3 PH			3.7	4.8						26					
AS-0678 Control Package - 10 HP 460V - 3 PH					1.7	2.1		13							
AS-0704 Control Package - 10 HP 575V - 3 PH					1.4	1.8	11								
AS-0670 Control Package - 15 HP 230V - 1 PH	6.4	8.0											55		
AS-0675 Control Package - 15 HP 230V - 3 PH			3.7	4.8							42				
AS-0679 Control Package - 15 HP 460V - 3 PH					1.7	2.1			21						
AS-0705 Control Package - 15 HP 575V - 3 PH					1.4	1.8		17							
AS-0676 Control Package - 20 HP 230V - 3 PH			3.7	4.8								54			
AS-0680 Control Package - 20 HP 460V - 3 PH					1.7	2.1				25					
AS-0706 Control Package - 20 HP 575V - 3 PH					1.4	1.8			21						
AS-0677 Control Package - 30 HP 230V - 3 PH			3.7	4.8										75	
AS-0681 Control Package - 30 HP 460V - 3 PH					1.7	2.1					37				
AS-0707 Control Package - 30 HP 575V - 3 PH					1.4	1.8				30					
AS-0671 Control Package - 40 HP 230V - 3 PH			3.7	4.8											95
AS-0682 Control Package - 40 HP 460V - 3 PH					1.7	2.1						51			
AS-0708 Control Package - 40 HP 575V - 3 PH					1.4	1.8					42				
<b>Twin Motor</b>															
AS-0668 Control Package - 10 HP 230V - 1 PH Twin	6.4	8.0									38				
AS-0667 Control Package - 15 HP 230V - 1 PH Twin	6.4	8.0											55		

# Schematic - 230V 1 PH - 10 HP Standard

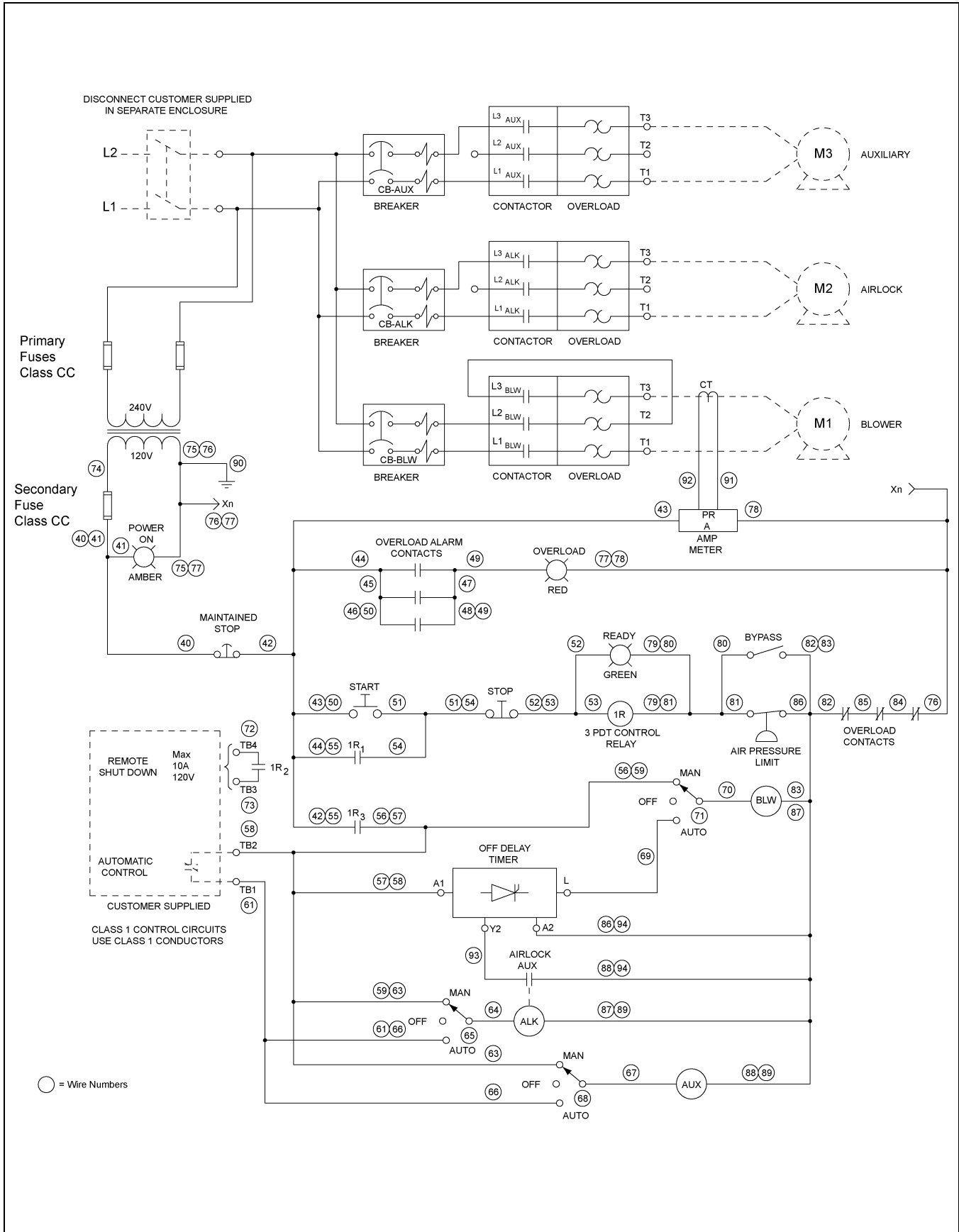

# 9. Schematic Diagrams

## Schematic - 230V 1 PH - 15 HP Standard

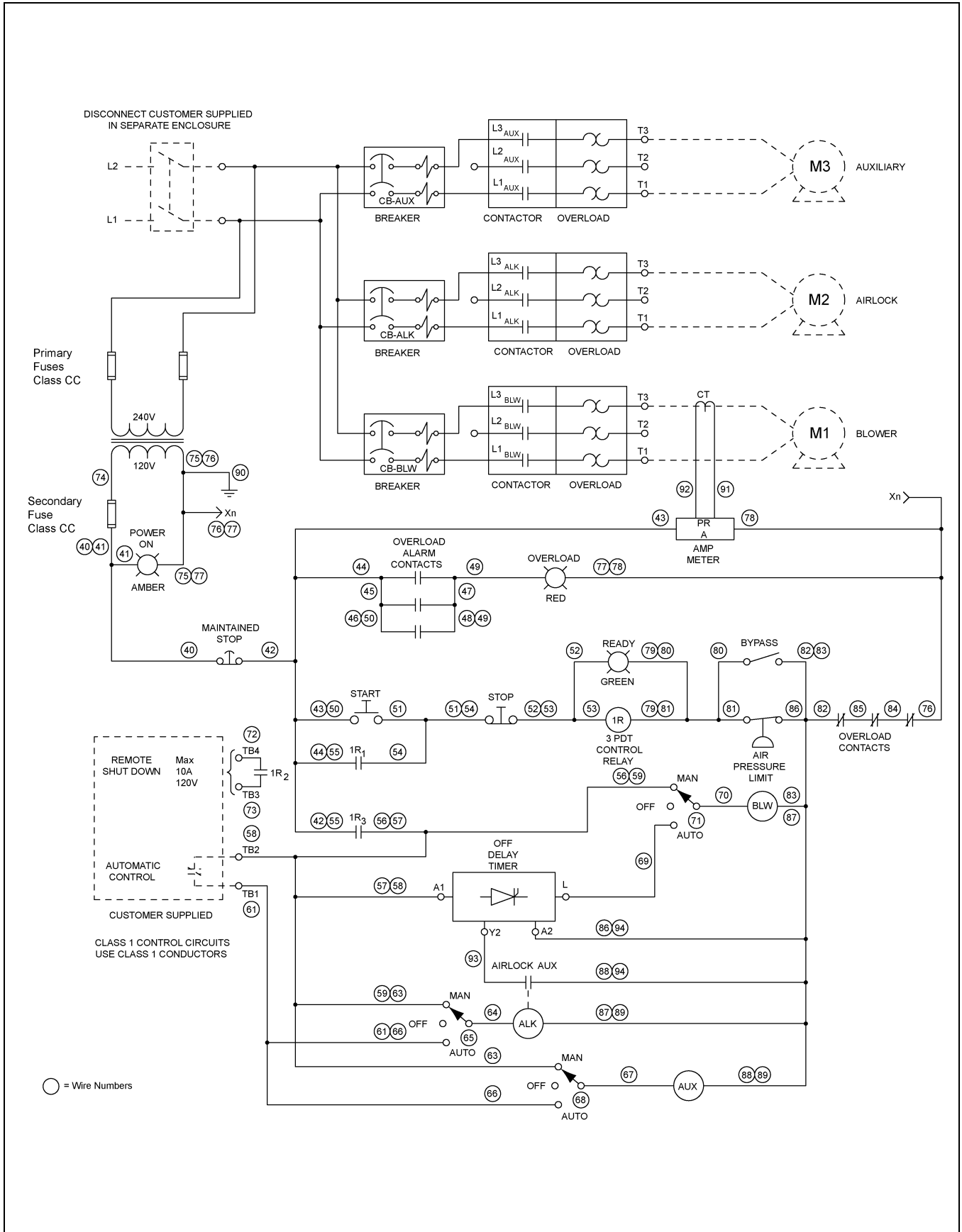

Schematic - 230V 1 PH - 10 HP Twin

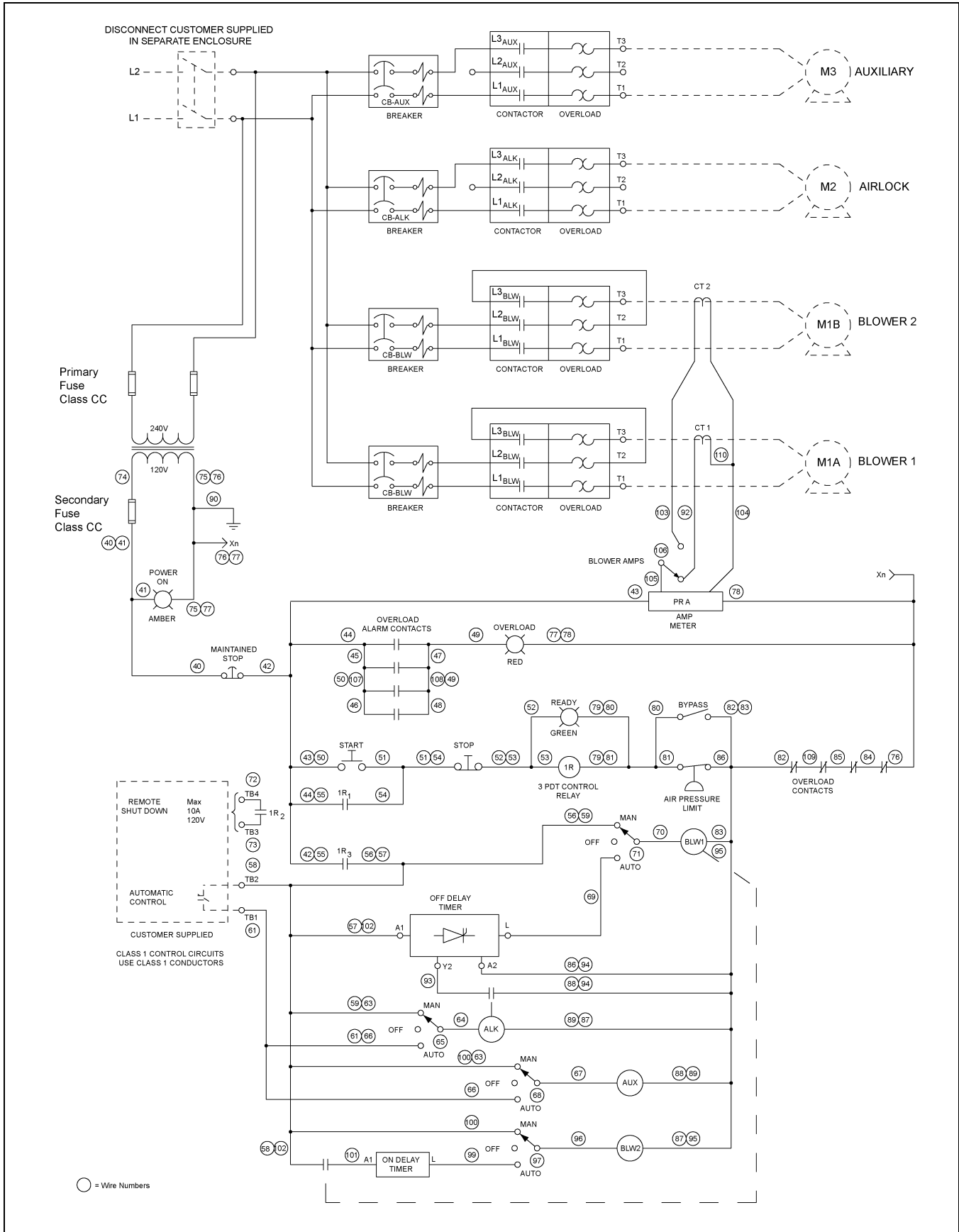

# 9. Schematic Diagrams

## Schematic - 230V 1 PH - 15 HP Twin

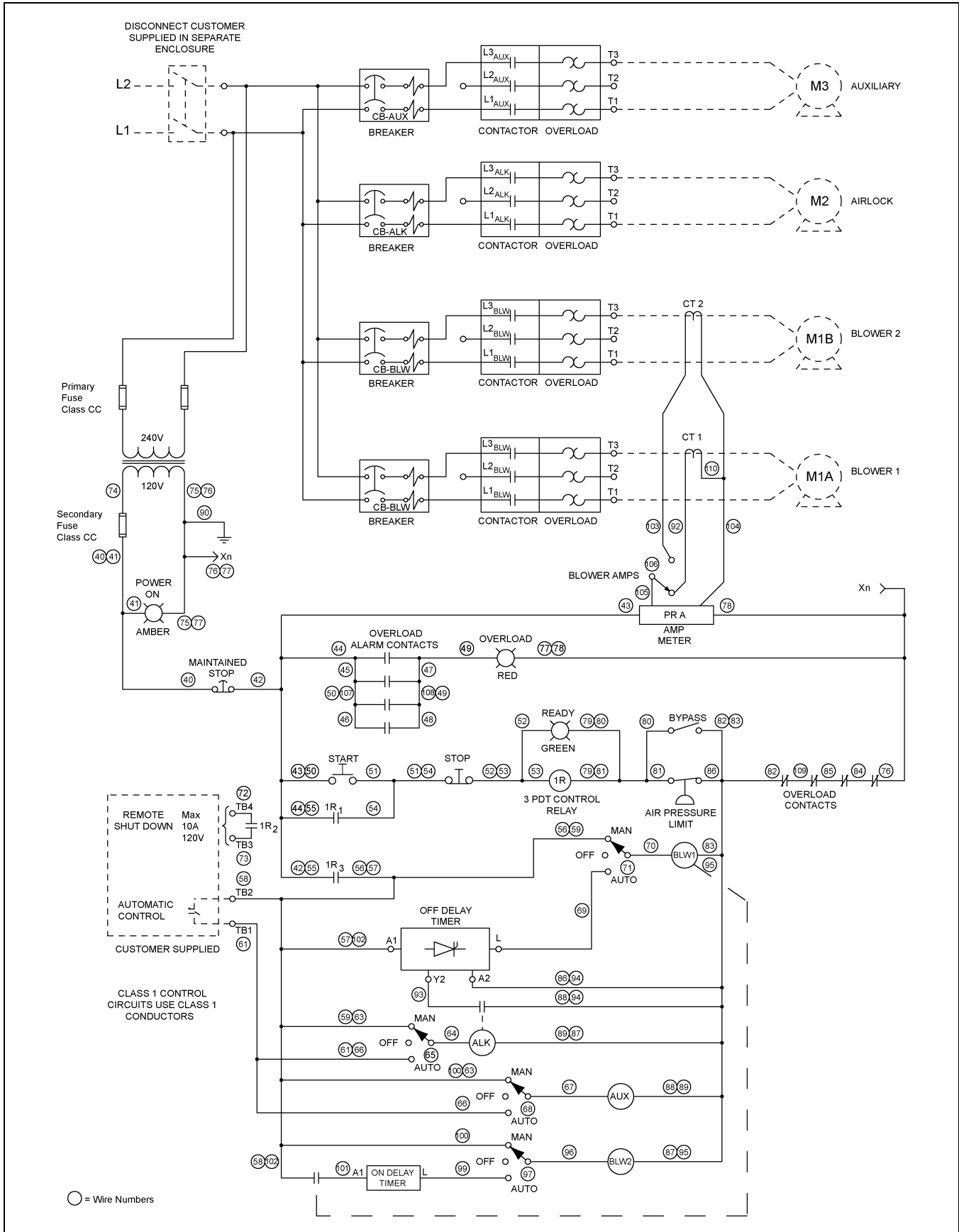



# Schematic - 230V/460V/575V - 3 PH

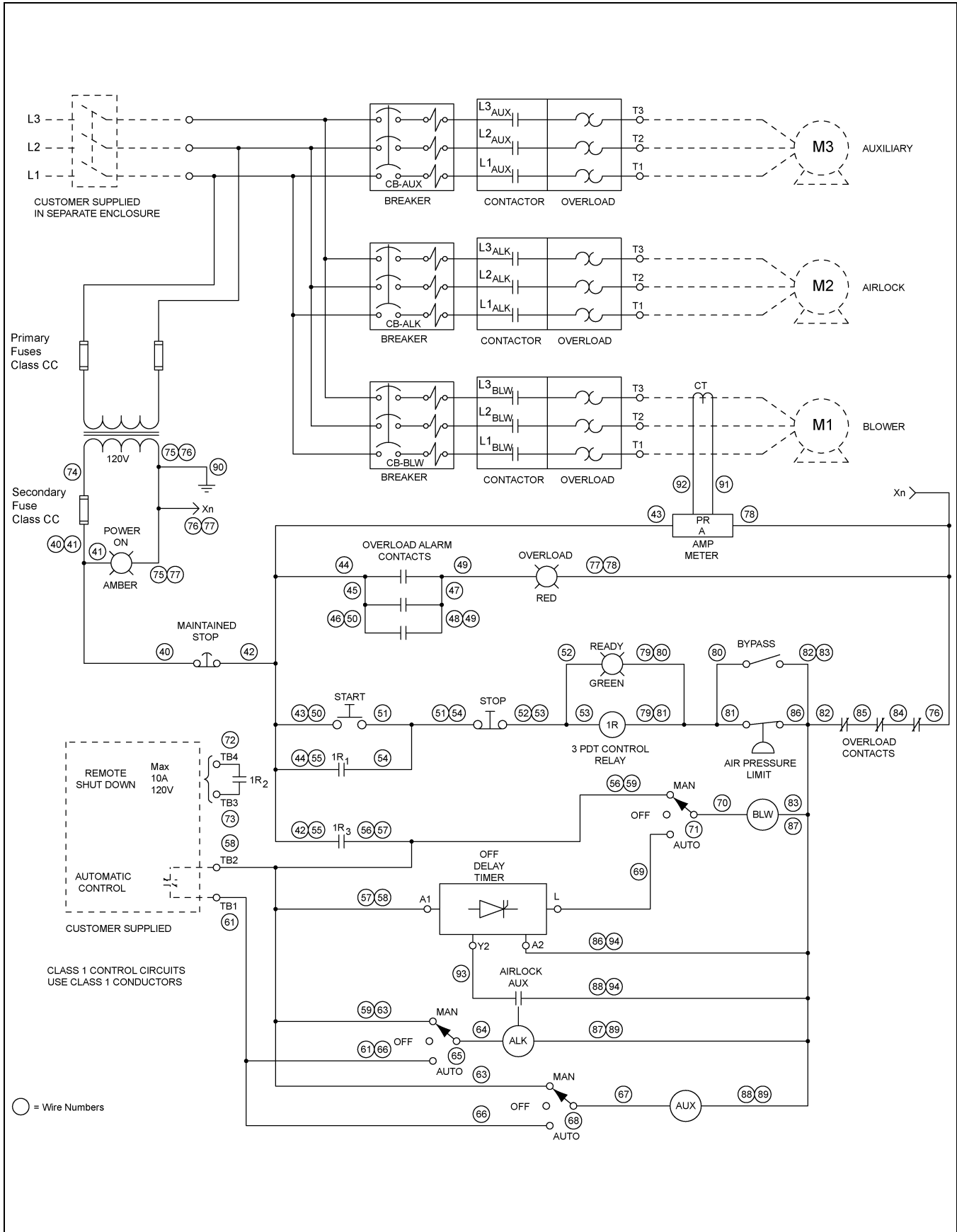

### Control Box Operational Procedures

#### Automatic operation using the automatic controller unit tied to terminals 1 and 2.

1. Switch all circuit breakers to the “ON” position.
2. Place the Blower, Airlock and Auxiliary Control switches in the “OFF” position.
3. Place the Air Pressure Limit Control switch in the “ON” position (unit will stop when the air pressure reaches 10 PSI).
4. Turn ON the power to the Air Systems control box. The power light should come ON.
5. Push the Start button. The control circuit ready light should come ON.
6. Place the Blower, Airlock and Auxiliary switches in the “AUTO” position.
7. The complete air system will now run when the automatic controller completes the circuit between terminals 1 and 2. When this circuit is broken, the airlock and auxiliary equipment will stop immediately, but the blower will continue to run for an additional 15 seconds to clear the tubing in the system.
8. The airlock, auxiliary equipment and blower will run when the control switches are placed in the “MANUAL” mode. The airlock, auxiliary equipment and blower will stop immediately when switched “OFF”.
9. Pushing the Stop button will immediately stop all air system functions as well as any equipment tied to terminals 3 and 4.

#### Operation of the air system WITHOUT an automatic controller tied to terminals 1 and 2.

1. Switch all circuit breakers to the “ON” position.
2. Place the Blower, Airlock and Auxiliary Control switches in the “OFF” position.
3. Place the Air Pressure Limit Control switch in the “ON” position (unit will stop when the air pressure reaches 10 PSI).
4. Turn ON the power to the Air System control box; the power light should come ON.
5. Push the Start button. The control circuit ready light should come ON.
6. The blower, airlock and auxiliary equipment can now be run by placing them in the “MANUAL” position. The airlock, auxiliary equipment and blower will stop immediately when switched OFF.
7. Pushing the Stop button will immediately stop all air system functions as well as any remote equipment tied to terminals 3 and 4.

## Air System Operation Guidelines

1. Be aware of the quality of grain that is entering and leaving the air system. Grain damage can occur with any pneumatic system unless care is taken to adjust the velocity of the grain. This can be done by opening or closing the outlet gate valve on the blower outlet of the Air System. Opening the valve will let air out of the tubing system which will slow the velocity of the air and grain in the tubing system. A recommended procedure is to open the valve slowly until the line pressure begins to surge and then to close it by 1/2 turn. This will provide the slowest possible grain velocity for any tubing system. This procedure for adjusting the air velocity should be repeated for each different tubing layout and capacity change.
2. If the tubing system should become plugged, place the air pressure limit switch to the "OFF" position, switch the airlock and auxiliary equipment to "OFF" and the blower to "MANUAL". Note the opening of the outlet gate valve, then open it completely so all the air is exhausted when the blower is started. Push the Start button and the blower will start. Slowly close the outlet gate valve until the grain starts moving and clears the tube. Adjust the valve as explained in [Step 1](#). It should be the same as noted before adjusting. Operate the airlock and auxiliary equipment in "MANUAL" until all grain is out of the system.



**Do not stand next to the exhausted air.**

3. The air pressure limit switch should always be in the "ON" position during routine operation to provide protection to the blower against overload conditions. The air pressure limit is set at the factory to shut down the system at 10 PSI. If adjustment is needed, rotate the adjusting screw counterclockwise to lower the pressure limit or clockwise to increase the pressure limit. A one-half (1/2) turn of the screw will change the pressure limit 1 PSI.

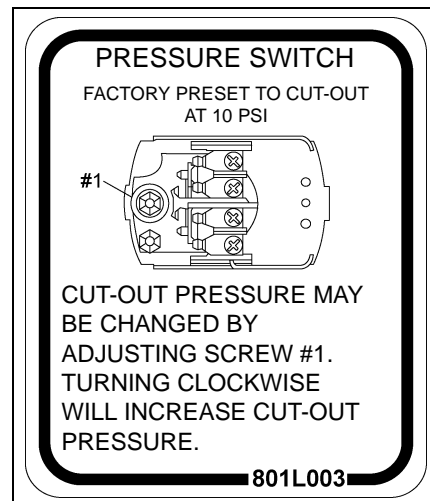

**Figure 10A**

**NOTE:** *If the pressure limit is set below 5 PSI, the switch may not reset and allow the air transfer to run. (See [Figure 10A](#).)*

4. The air filter element should be inspected daily and cleaned when required. Both the poly foam pre-filter and the filter element can be cleaned by blowing air through them or washing them with mild detergent and water. A restricted air filter will cause a system to become plugged. It should always be inspected whenever plugging occurs.
5. The airlock is provided with a housing that incorporates grain shear protection to prevent grain damage.

## 10. Operation and Management

### 6. GUIDELINES FOR OPERATION OF AIR SYSTEMS

- a. Grain in a pneumatic air system running at full capacity will move at about 60% of the air speed. A system operating at low capacities will move grain at 80%-90% of the air speed.
- b. Decreasing the amount of air in the system (opening the hand gate valve) will cause the grain to move slower and also cause the air pressure to rise. (Essentially, the grain is causing the air to “pile up”.)
- c. Increasing the air in a system (closing the gate valve) will increase the grain velocity and lower the pressure.
- d. TYPICAL RUNNING CONDITIONS ARE:
  - A 4" system running full with 15 HP will have a system pressure of 4-5 PSI.
  - A 5" system running full with 30 HP will have a system pressure of 5-6 PSI.
  - A 5" system running full with 40 HP will have a system pressure of 6-7 PSI.

### 7. OPERATION OF TWIN MOTOR TRANSFER OPTION

The twin motor option allows an air system to use two (2) 1 phase motors to provide extra power when 3 phase electricity is not available.

The twin motor control box is different from the standard control box because it has an additional magnetic contactor and an “On-Delay” timer for stagger starting the second motor to minimize voltage drop during the starting operation. It also has a selection switch to display the amperage of each motor.

It is important to use two (2) motors of similar model and size because it is normal for motors to run at slightly different amperages and for one to be more heavily loaded than the other. Using similar motors will minimize this condition.

Check the amperage of each motor periodically by using the selection switch on the control panel. Leave the switch in position to monitor the motor with the highest amperage. It is important to periodically check both motor amperages to ensure that they are sharing the load. For example, if the belts for one motor would start to slip, then the other motor would take on the additional load and become overloaded.

**NOTE:** *Twin drive capacities are approximately 80% of single drive units.*

### 8. RECOMMENDATIONS FOR OFF-SEASON STORAGE

The blower and airlock have precision machined components and must be protected to prevent corrosion and rust from forming on the blower lobes and airlock vanes. These parts should be coated with motor oil after each drying season. (Spray lubricants such as WD-40 do not usually provide adequate protection.)

Both the airlock and blower assemblies should be carefully protected from the weather and the piping system disconnected from the blower and airlock. Remove the transition connection to the airlock inlet and re-install the weather cover shipped with the airlock. This is important to prevent condensation from collecting in the airlock and blower.

### Wiring for a surge tank hooked to an Air System

The Air System will start when both  $P_1$  and  $P_2$  are closed. As it empties,  $P_1$  will open but will not stop the unit due to auxiliary contacts being closed. When  $P_2$  opens, the unit will stop.

**NOTE:** Be sure the auxiliary switch is in the "AUTO" position.

$P_1$  and  $P_2$  are pressure switches.

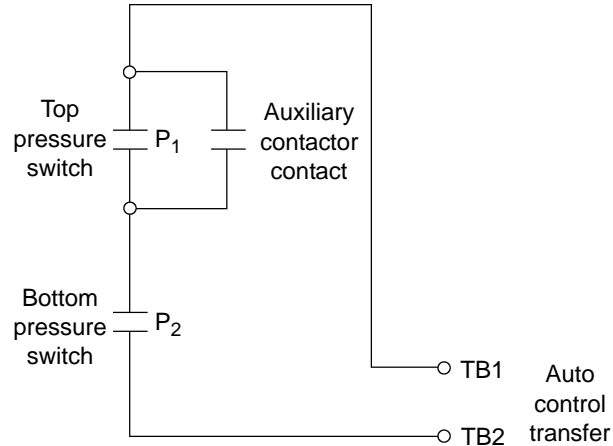

### How to hook-up Air System to remote equipment

Remote equipment control circuit

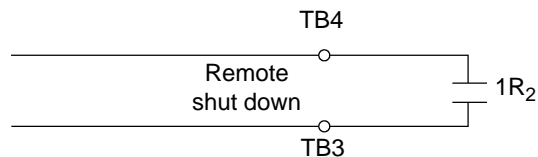

Any contact that closes upon start and opens on stop. (**NOTE:** This contact must not have any external AC power.)

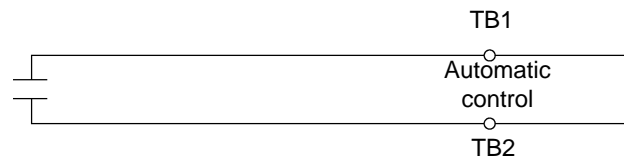

With the above hook-up, the Air System must be started before the remote equipment. If the Air System is manually turned OFF or turned OFF from high pressure or an overload, the remote equipment will also turn OFF.

TB3 and TB4 will have a closed contact ( $1R_2$ ) as long as the air system has the "ready" indicator (located in the control box) ON. The automatic control TB1 and TB2 requires a closed contact across them to start the air system unit.

## 11. Hook-Up Diagrams

### Programming Parameters for PR Electronics 5714A

To begin programming: Turn power ON, then press OK.

Ref #	On Display	Action	Set to Value	End
1	IN	Press either Arrow	CURR	Press OK
2	RANG	Press either Arrow	4-20	Press OK
3	DEC.P	Press either Arrow	<a href="#">See Note 1</a>	Press OK
4	DI.LO	Press either Arrow	0	Press OK
5	DI.HI	Press either Arrow	<a href="#">See Note 2</a>	Press OK
6	EPAS	Press either Arrow	No	Press OK
7	-	END of Inputs		

#### NOTES:

1. This parameter determines the location of the decimal point in the displayed value. This should be set to 11.11 for values of 10-99 and 111.1 for values greater than 100.
2. This parameter determines the scale of the displayed value and should be matched to the control transformer range setting such as 30, 60, 120 for H921 or 200 for 721HC.

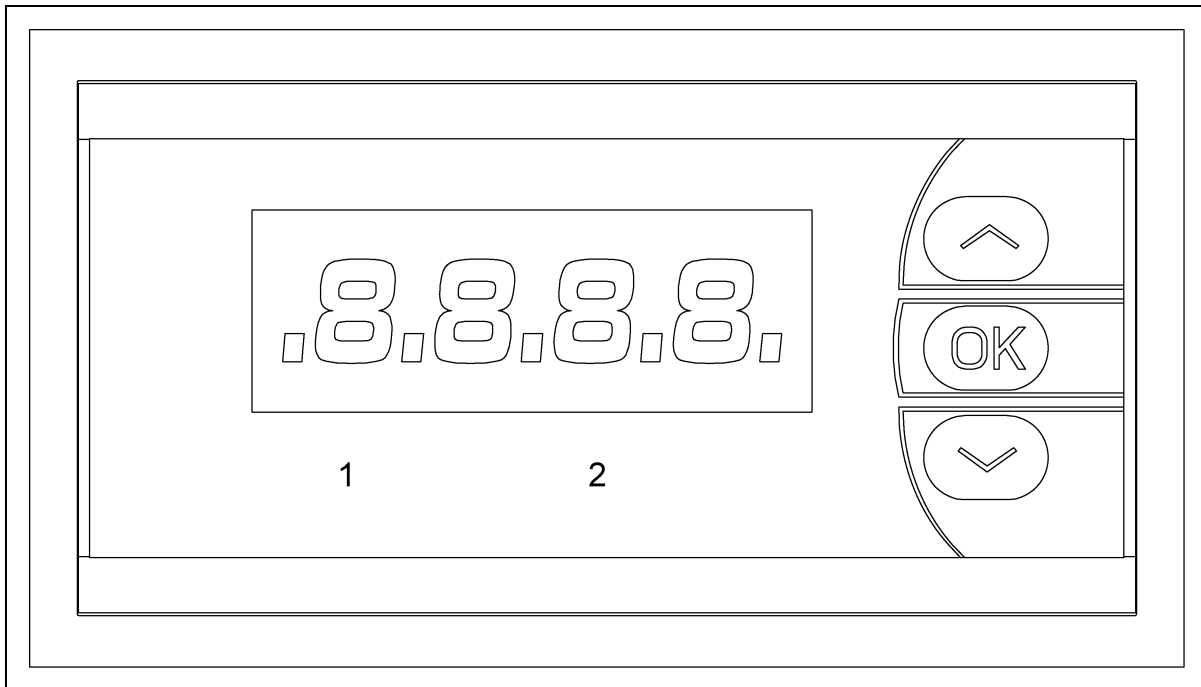
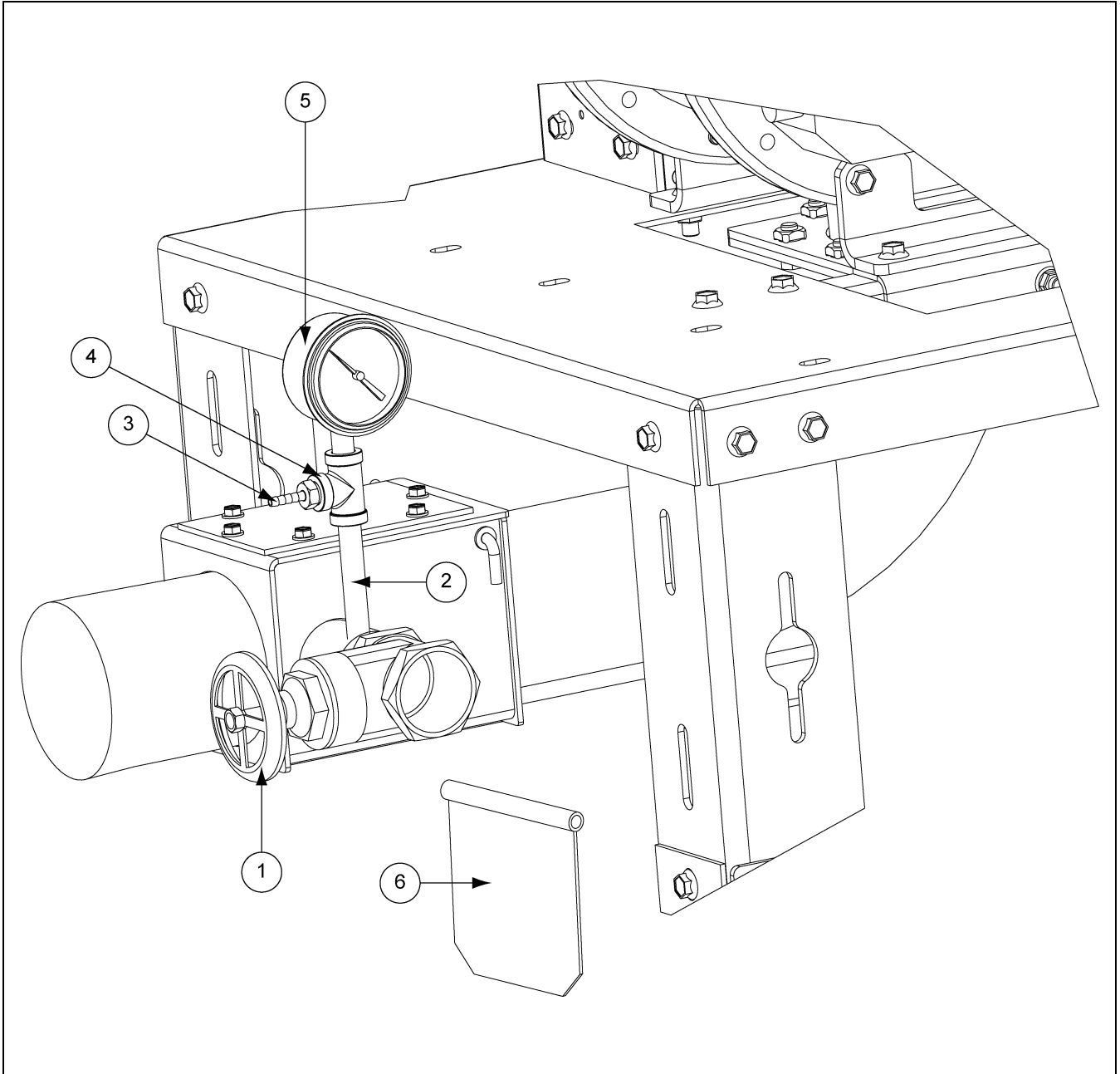

Figure 11A Blower Amps

1. **Blower Outlet Parts** - *(See Page 40 and 41.)*
2. **4" (700) and 5" (1200) Standard Blower Parts** - *(See Page 42 and 43.)*
3. **4" and 5" Twin Blower Parts** - *(See Page 44 and 45.)*
4. **5" (1700) High-Capacity Blower Parts** - *(See Page 46 and 47.)*
5. **5" (1700) Twin High-Capacity Blower Parts** - *(See Page 48 and 49.)*
6. **4" and 5" Blower Filters** - *(See Page 51.)*
7. **4" and 5" Airlock Parts** - *(See Page 52 and 53.)*
8. **Airlock Inlet Transition Assembly** - *(See Page 54 and 55.)*
9. **4" and 5" Air Selector Valve** - *(See Page 56-59.)*
10. **4" and 5" Deadhead Deflector Assembly for 90° Spout** - *(See Page 60.)*
11. **4" and 5" Deadhead Deflector Assembly for 60° Spout** - *(See Page 61.)*
12. **4" and 5" Valve Assembly** - *(See Page 62 and 63.)*
13. **Air System Cyclone Package** - *(See Page 64.)*
14. **Air System Cyclone Package Small** - *(See Page 65.)*
15. **Inner Door Assembly - Standard** - *(See Page 66.)*
16. **Inner Door Assembly - Twin** - *(See Page 67.)*
17. **Standard Control Panel Assembly 230V - 1 Phase** - *(See Page 68 and 69.)*
18. **Twin Control Panel Assembly 230V - 1 Phase** - *(See Page 70 and 71.)*
19. **Standard Control Panel Assembly 10-40 HP 230V - 3 Phase** - *(See Page 72 and 73.)*
20. **Standard Control Panel Assembly 10-40 HP 460V - 3 Phase** - *(See Page 74 and 75.)*
21. **Standard Control Panel Assembly 10-40 HP 575V - 3 Phase** - *(See Page 76 and 77.)*

## Blower Outlet Parts





## Blower Outlet Parts List

Ref #	Part #	Description	Qty		
			4"	5"	6"
1	PT1132	Gate Valve, 1-1/2" NPT	1	1	1
2	4FH0509	Pipe Nipple, 1/4" NPT x 3 Galv. SCH 40	1	1	1
3	4FH0971	Hose Barb, 1/4" x 1/4" MPT Brass	1	1	1
4	4FH0581	Pipe Tee, 1/4" FPT Galv.	1	1	1
5	PT1127	Gauge, Oil Filled 0-15 PSI	1	1	1
6	8021235	Check Valve Plate Weld - 4"	1	-	-
6	8021235	Check Valve Plate Weld - 5"	-	1	-
6	8041200	Check Valve Plate Weld - 6"	-	-	1

# 4" (700) and 5" (1200) Standard Blower Parts

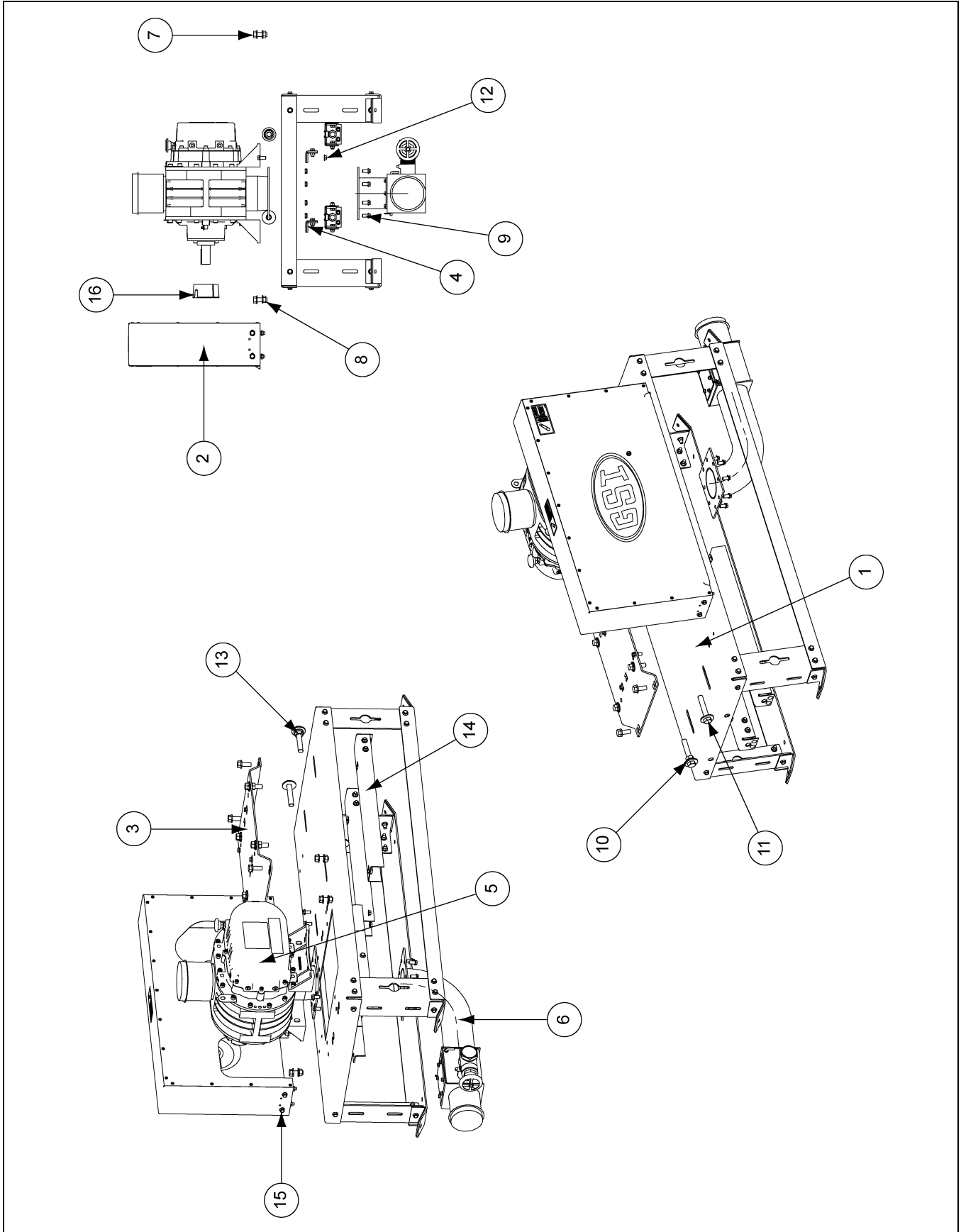

## 4" (700) and 5" (1200) Standard Blower Parts List

Ref #	Part #	Description	Qty	
			4"	5"
1	AS-0003-GD	Blower Base Assembly - 4" and 5" - GD	1	1
2	AS-0108	Air System-Blower Guard Assembly - Standard	1	1
3	AS-0047	Motor Mounting Plate Assembly - 4" Air Systems	1	-
3	AS-0058	Motor Mounting Plate Assembly - 5" Air Systems	-	1
4	AS-0042-GD	Blower Support/Shim Assembly - 4" and 5" - GD	2	2
5	8011266-GD	Blower Sub-Assembly 4" and 5" Standard DMC	1	1
6	AS-0088-D	Blower Outlet Elbow Assembly - 4" Standard DMC	1	-
6	AS-0092-D	Blower Outlet Elbow Assembly - 5" Standard DMC	-	1
7	S-9062	Flange Bolt 1/2"-13 x 1-1/4" ZN Grade 5	8	8
8	S-8506	Flange Nut 1/2"-13 ZN	4	4
9	S-9067	Flange Bolt 3/8"-16 x 3/4" ZN Grade 5	12	12
10	S-858	Flat Washer 5/8" USS ZN	2	2
11	2FH1043	Bolt, HHTB 5/8"-11 x 3-1/2" ZN Grade 2	2	2
12	S-968	Flange Nut 3/8"-16 ZN Grade 5	4	4
13	S-9259	Flange Nut 5/8"-11 ZN	1	1
14	AS-0025	Motor Adjust Rail Assembly	2	2
15	S-6606	Flange Bolt 5/16"-18 x 3/4" ZN Grade 5	4	4
16	MHC00742	Bushing, 2517 x 1-1/8" TL	1	1

Motors and Drive Parts (Not Shown)				
Part #	Description	Qty		
		4"	5"	
MHC00717	Sheave, 3 Grade, A9.0-B9.4 - 2517 TL, 9-3/4" O.D.	-	x	
MHC60010-1	Motor 10 HP 1 PH 1800 RPM	x	x	
MTR-0052	Motor 10 HP 3 PH 1800 RPM	x	x	
CH-5753	Motor 15 HP 1 PH 1800 RPM ODP	x	x	
3EL5069	Motor 15 HP 1 PH 1800 RPM TEFC	x	x	
MTR-0022	Motor 15 HP 3 PH 1800 RPM	x	x	
MTR-0025	Motor 20 HP 3 PH 1800 RPM	x	x	
MHC00024	Bushing, 2517 x 1-5/8" TL	-	x	
MTR-0056	Motor 30 HP 3 PH 1800 RPM	-	x	
CE-00598	Bushing SK 1-7/8" Bore QD Style	-	x	
PT0778	Bushing SK 1-3/8" Bore QD Style	x	-	
GC03810	Bushing SK 1-5/8" Bore QD Style	x	-	
PT0666	Pulley QD 8.95 O.D. x SK Bushing 3AB	x	-	

# 4" and 5" Twin Blower Parts

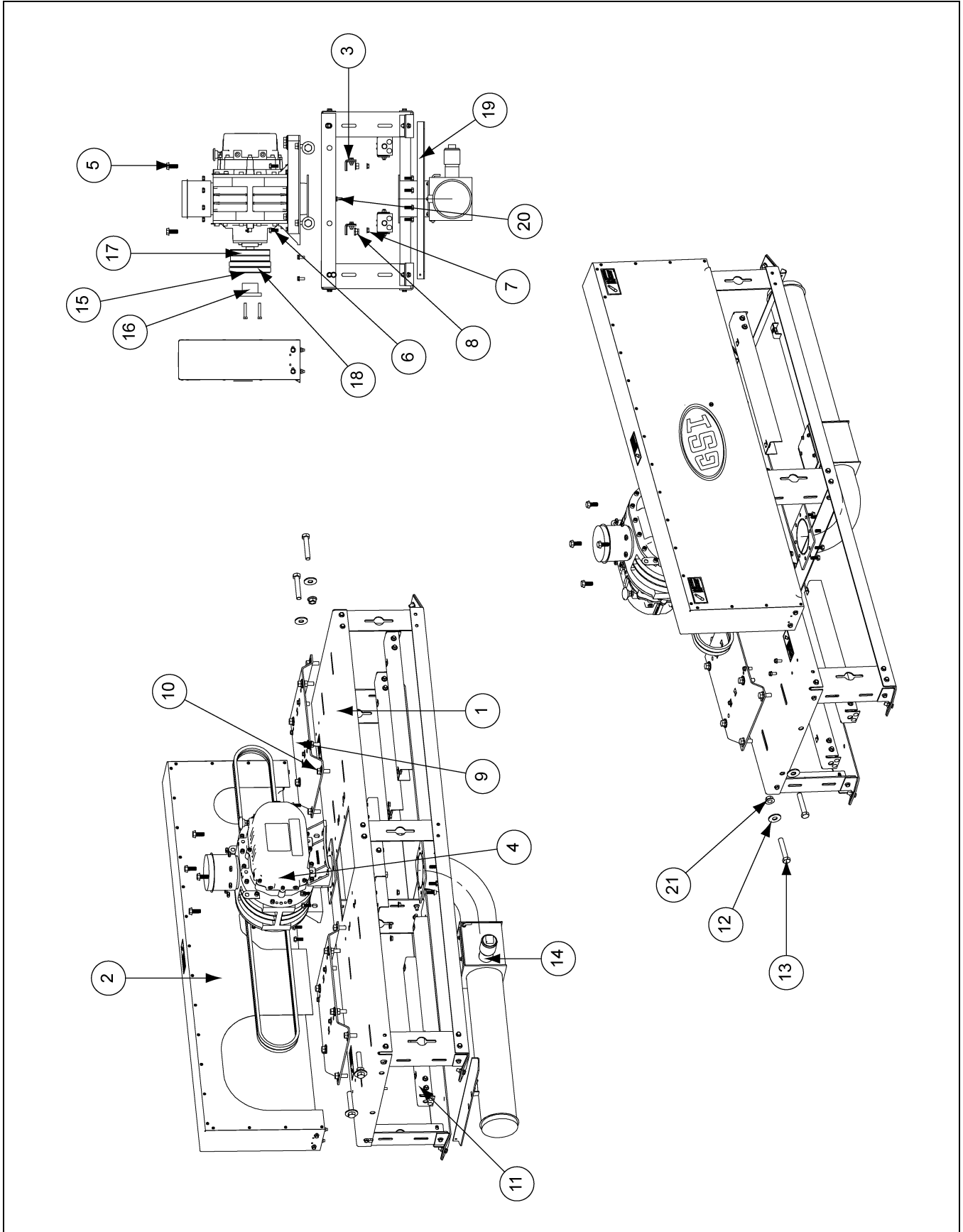

## 4" and 5" Twin Blower Parts List

Ref #	Part #	Description	Qty	
			4"	5"
1	AS-0007-GD	Blower Base Assembly - 4" and 5" Twin - GD	1	1
2	AS-0110	Air System Blower Guard Assembly - Twin	1	1
3	AS-0042-GD	Blower Support/Shim Assembly - 4" and 5" - GD	2	2
4	8011266-GD	Blower Sub-Assembly 4" and 5" Standard DMC	1	1
5	S-9062	Flange Bolt 1/2"-13 x 1-1/4" ZN Grade 5	4	4
6	S-9065	Flange Bolt 3/8"-16 x 1" ZN Grade 5	18	18
7	S-968	Flange Nut 3/8"-16 ZN Grade 5	10	10
8	S-8506	Flange Nut 1/2"-13 ZN	4	4
9	AS-0047	Blower Motor Mounting Plate Assembly - 4"	2	2
10	S-9062	Flange Bolt 1/2"-13 x 1-1/4" ZN Grade 5	8	8
11	AS-0025	Motor Adjust Rail Assembly	4	4
12	S-858	Flat Washer 5/8" USS ZN	4	4
13	2FH1043	Bolt, 5/8"-11 x 3-1/2" HHTB Grade 2 Plated	4	4
14	AS-0048-D	Blower Out Elbow Assembly - 4" Standard Twin DMC	1	-
14	AS-0054-D	Blower Out Elbow Assembly - 5" Standard Twin DMC	-	1
15	PT0741	Pulley QD 5-1/2" O.D. x SD Bush 4AB	1	1
16	PT0794	Bushing SD x 1-1/8" Bore	1	1
17	MHC00028	V-Belt BX60	2	2
18	MHC00743	V-Belt BX65	2	2
19	AS-0085	Support Angle - Blower Outlet Twin	1	1
20	S-6606	Flange Bolt 5/16"-18 x 3/4" ZN Grade 5	5	5
21	S-9259	Flange Nut 5/8"-11 ZN	2	2

Motors and Drive Parts (Not Shown)			
Part #	Description	Qty	
		4"	5"
MHC00110	Sheave, 2 Grade, A9.0-B9.4 - 2517 TL, 9-3/4" O.D.	-	x
002-1054-2	Motor 7-1/2 HP 1 PH 1800 RPM	x	-
MHC60010-1	Motor 10 HP 1 PH 1800 RPM	x	x
MHC00065	Bushing, 2517 x 1-3/8" T.L.	x	x
CH-5753	Motor 15 HP 1 PH 1800 RPM ODP	-	x
3EL5069	Motor 15 HP 1 PH 1800 RPM TEFC	-	x
MHC00024	Bushing, 2517 x 1-5/8" TL	-	x
PT0778	Bushing SK 1-3/8" Bore QD Style	x	-
PT0749	Pulley QD 8.95 O.D. x SK Bushing 2AB	x	-

# 5" (1700) High-Capacity Blower Parts

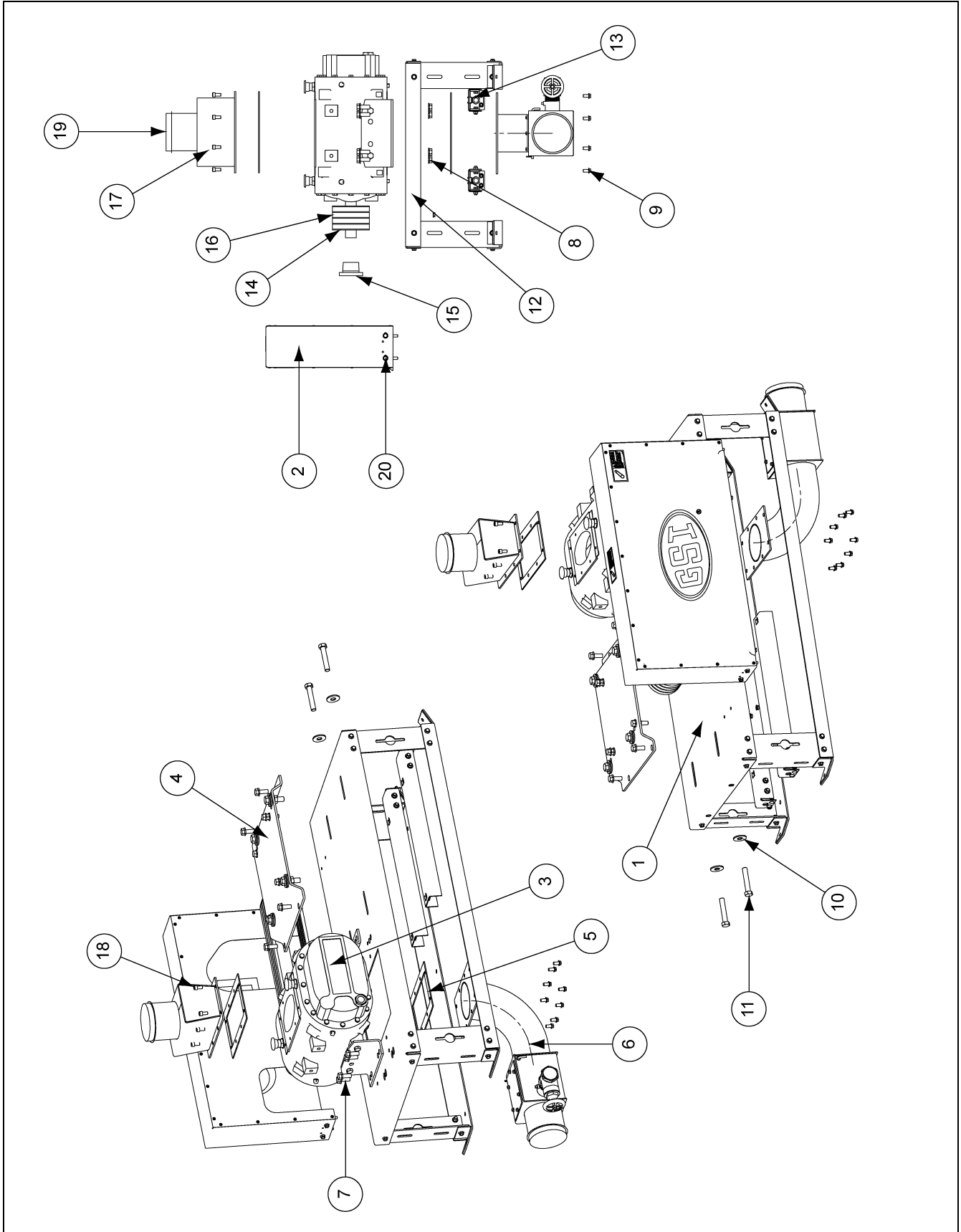

## 5" (1700) High-Capacity Blower Parts List

Ref #	Part #	Description	Qty
1	AS-0003-GD	Blower Base Assembly - 4" and 5"	1
2	AS-0108	Dive Guard Assembly - 4" and 5" Standard Blower	1
3	AS-0882	Blower, 5", GD - Duro Flow 4509	1
4	AS-0058	Motor Mounting Plate Assembly - 5" Air Systems	1
5	802B006	Blower Gasket - 5" High-Capacity	2
6	AS-0094-D	Blower Outlet Elbow Assembly - 5" High-Capacity DMC	1
7	S-9062	Flange Bolt 1/2"-13 x 1-1/4" ZN Grade 5	12
8	S-8506	Flange Nut 1/2"-13 ZN	8
9	S-9067	Flange Bolt 3/8"-16 x 3/4" ZN Grade 5	8
10	S-858	Flat Washer 5/8" USS ZN	2
11	2FH1043	Bolt, 5/8"-11 x 3-1/2" HHTB Grade 2 Plated	2
12	S-9259	Flange Nut 5/8"-11 ZN	1
13	AS-0025	Motor Adjust Rail Assembly	2
14	PT0736	Sheave, 4 Grade, A 4.2-B 4.6 - SD, 4.95" O.D.	1
15	GC06682	Bushing SD x 1-7/16" Bore	1
16	MHC00028	V-Belt BX60	4
17	8021130-RD	Blower Inlet - 5" High-Capacity Red	1
18	S-8898	Bolt, SHCS 3/8"-16 x 3/4" Black	8
19	MS0063	Cap, Plastic 5" I.D. Tube Orange	1
20	S-6606	Flange Bolt 5/16"-18 x 3/4" ZN Grade 5	4

Motors and Drive Parts (Not Shown)		
Part #	Description	Qty
GC06676	Sheave, 4 Grade, A7.6-B8.0 - SK, 8.35" O.D.	x
MTR-0022	Motor 20 HP 3 PH 1800 RPM	x
MHC00024	Bushing, 2517 x 1-5/8" TL	x
MTR-0056	Motor 30 HP 3 PH 1800 RPM	x
CE-00598	Bushing, 2517 x 1-7/8" TL	x
MTR-0063	Motor 40 HP 3 PH 1800 RPM	x
PT0784	Bushing SK 2-1/8" Bore QD Style	x

# 5" (1700) Twin High-Capacity Blower Parts

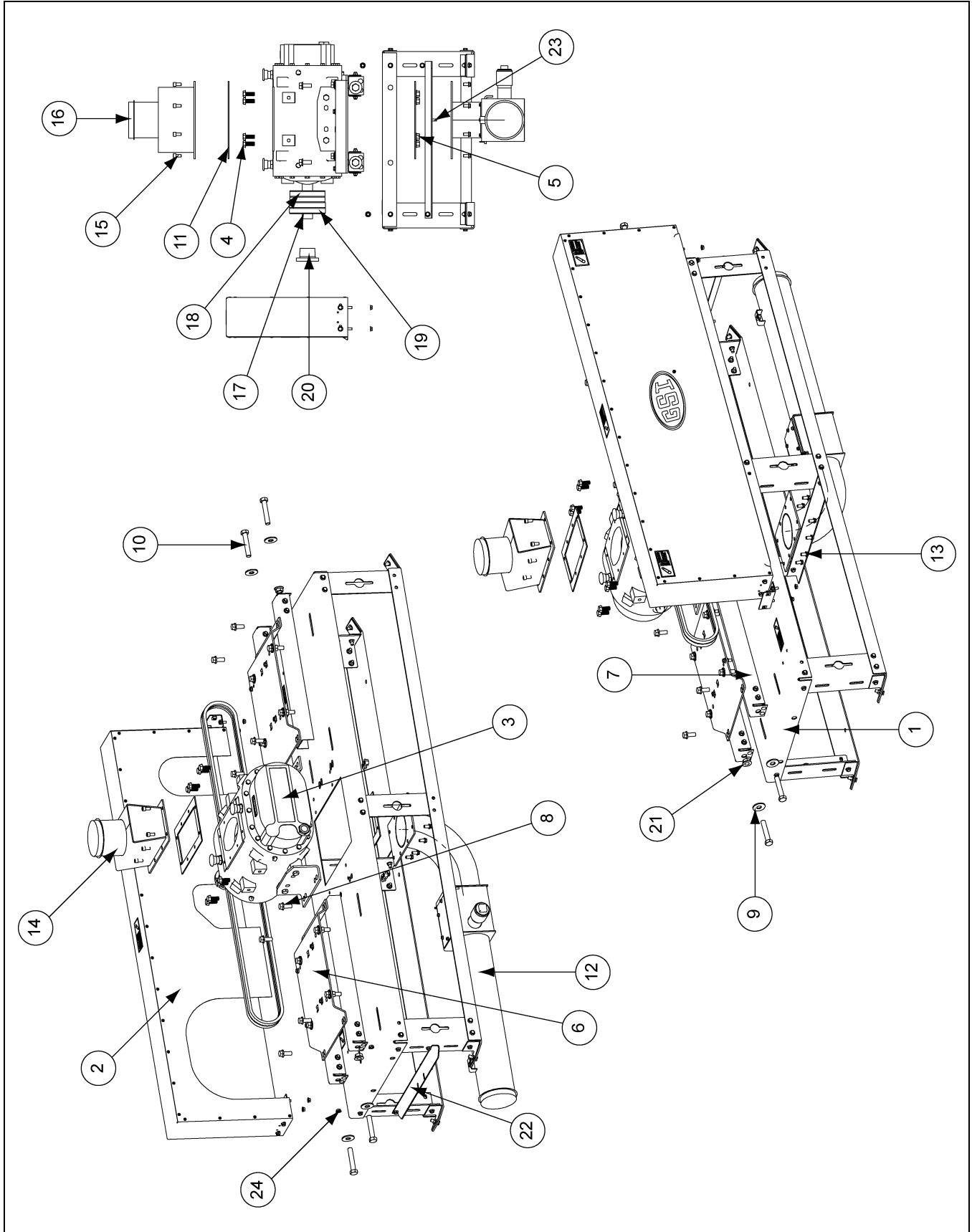



## 5" (1700) Twin High-Capacity Blower Parts List

Ref #	Part #	Description	Qty
1	AS-0007-GD	Blower Base Assembly - 4" and 5" Twin - GD	1
2	AS-0110	Air System-Blower Guard Assembly - Twin	1
3	CA-1059-GD	5" Blower Sub-Assembly - DMC, GD	1
4	S-9062	Flange Bolt 1/2"-13 x 1-1/4" ZN Grade 5	8
5	S-8506	Flange Nut 1/2"-13 ZN	8
6	AS-0047	Motor Mounting Plate Assembly - 4" Air System	2
7	AS-0025	Motor Adjust Rail Assembly	4
8	S-9062	Flange Bolt 1/2"-13 x 1-1/4" ZN Grade 5	8
9	S-858	Flat Washer 5/8" USS ZN	4
10	2FH1043	Bolt, 5/8"-11 x 3-1/2" HHTB Grade 2 Plated	4
11	802B006	Blower Gasket - 5" High-Capacity	2
12	AS-0051-D	Elbow Assembly-Blower Out 5" High Twin DMC	1
13	S-9067	Flange Bolt 3/8"-16 x 3/4" ZN Grade 5	10
14	8021130-RD	Blower Inlet - 5" High-Capacity Red	1
15	S-8898	Bolt, SHCS 3/8"-16 x 3/4" Black	8
16	MS0063	Cap, Plastic 5" I.D. Tube Orange	1
17	PT0736	Sheave, 4 Grade, A 4.2-B 4.6 - SD, 4.95" O.D.	1
18	MHC00028	V-Belt BX60	2
19	MHC00743	V-Belt BX65	2
20	GC06682	Bushing SD x 1-7/16" Bore	1
21	S-9259	Flange Nut 5/8"-11 ZN	2
22	AS-0085	Support Angle - Blower Outlet Twin	1
23	S-6606	Flange Bolt 5/16"-18 x 3/4" ZN Grade 5	5
24	S-968	Flange Nut 3/8"-16 ZN Grade 5	2

Motors and Drive Parts (Not Shown)		
Part #	Description	Qty
MHC00110	Sheave, 2 Grade, A9.0-B9.4 -2517 TL, 9-3/4" O.D.	x
MHC60010-1	Motor 10 HP 1 PH 1800 RPM	x
MHC00065	Bushing, 2517 x 1-3/8" TL	x
CH-5753	Motor 15 HP 1 PH 1800 RPM ODP	x
3EL5069	Motor 15 HP 1 PH 1800 RPM TEFC	x
MHC00024	Bushing, 2517 x 1-5/8" TL	x

## 12. Parts List

If replacing a roots-flo blower, use the following chart to determine the appropriate service kit.

**Service Kit Cross Reference Sheet**

System Size	Series	Kit PN to be Ordered	Drive	HP	Line Items to be Ordered with Kit		Qty
4" Systems	All	AS-0889	Single	All	MHC00113	Blower Sheave	1
					MHC00742	Blower Bushing	1
			Twin	All	MHC00771	Blower Sheave	1
					MHC00742	Blower Bushing	1
5" Systems	1200 Series	AS-0890	Single	20	MHC00717	Motor Sheave	1
					MHC00024	Motor Bushing	1
				30	MHC00717	Motor Sheave	1
					CE-00598	Motor Bushing	1
			Twin	10	MHC00110	Motor Sheave	2
					MHC0065	Motor Bushing	2
	15	MHC00110		Motor Sheave	2		
		MHC00024		Motor Bushing	2		
1700 Series	AS-0891	All	All	None	-	0	
6" Systems	All	AS-0892	Single	40	GC06676	Motor Sheave	1
					75	MHC01829	Motor Sheave
				CE-00598		Motor Bushing	1
				50-60	MHC01420	Motor Sheave	1
					CE-00598	Motor Bushing	1
					MHC00791	Blower Sheave	1
					CE-00597	Blower Bushing	1

\* For example: To order a service kit for a 5" 1200 series, single drive, 30 HP air system, you must order 1, AS-0890, 1, MHC00717 and 1, CE-00598.

## 4" and 5" Blower Filters

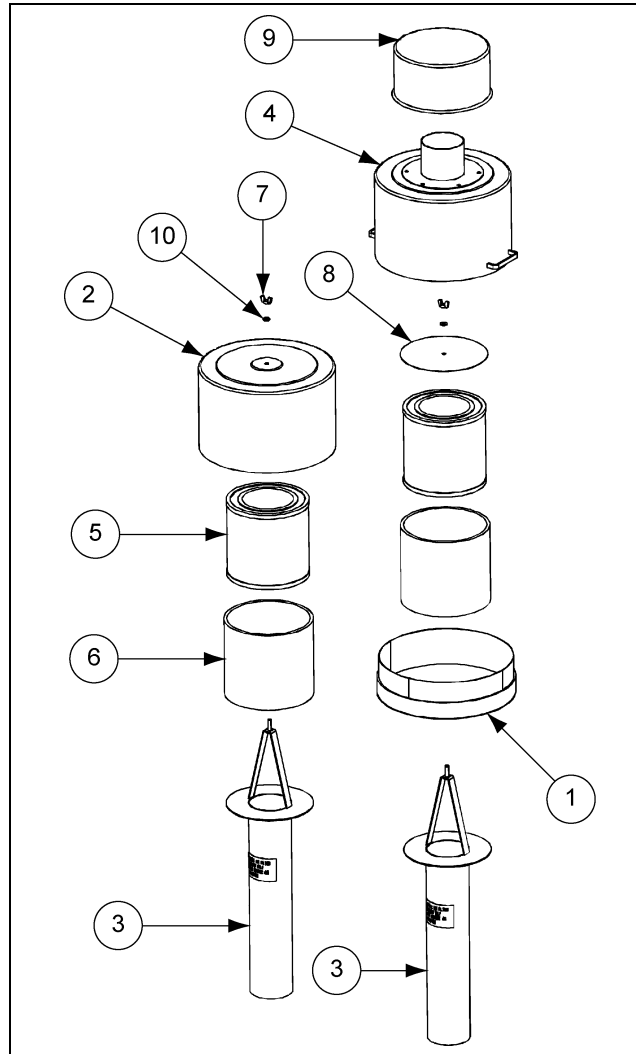

**4" and 5" Blower Filters Parts List**

Ref #	Part #	Description	Qty
1	8021224-Y	Air System, Prefilter Base 5" Ochre	1
2	801A104-Y	Canister - Air Filter - 16" Ochre	1
3	802A072-D	Filter Base - 5" Assembly	1
4	8021219-D	Pre-Cleaner Canister Assembly	1
5	801A154	Filter, Inner, 10 Micron	1
6	801A156	Filter, Outer, (Pre-Foam)	1
7	S-1451	Wing Nut 3/8"-16 UNC Plated	1
8	8021228	Plate-Filter Top Pre-Cleaner (4" and 5" Air Systems)	1
9	MS5466	Pre-Cleaner - 5" Inlet Centrifugal (350-700 CFM)	1
10	S-248	Flat Washer Standard 3/8", Plated	1

# 4" and 5" Airlock Parts

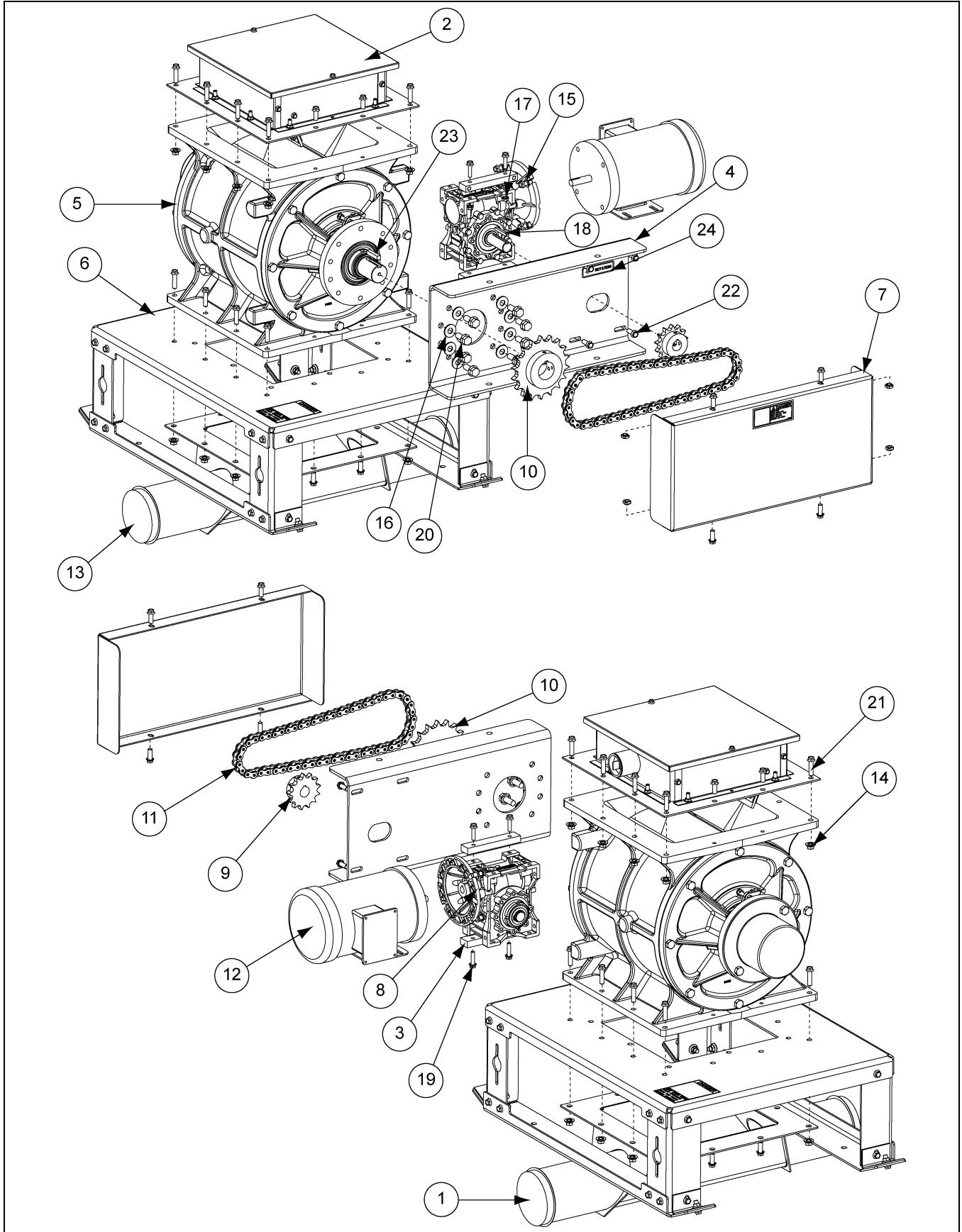

## 4" and 5" Airlock Parts List

Ref #	Part #	Description	Qty	
			4"	5"
1	AS-0037-BS	Airlock Hopper Weld - 4" Bin Silver	1	-
1	AS-0034-BS	Airlock Hopper Weld - 5" Bin Silver	-	1
2	AS-0070	Airlock Inlet Assembly - 4"	1	-
2	AS-0072	Airlock Inlet Assembly - 5"	-	1
3	AS-0901-BS	Airlock, Drive Mount Bar - Bin Silver	2	2
4	AS-0902-Y	Airlock, Drive Mount Plate Weld Ochre	1	1
5	AS-0904	Airlock, 4" Air System, 12" MFT	1	-
5	AS-0905	Airlock, 5" Air System, 14" MFT	-	1
6	AS-0909	Airlock, Meyer Base Assembly - 4" and 5"	1	1
7	AS-0928	Airlock, Drive Cover Assembly	1	1
8	AS-0916	Gearbox, NMRL-P06 with Limiter, 30:1, 56C, 1.0" Shaft	1	1
9	AS-0920	Sprocket, #60 13T 1" Bore with Set Screws	1	1
10	AS-0921	Sprocket, #60 24T 1-1/2" Bore with Set Screws, 700 Systems	1	-
10	AS-0922	Sprocket, #60 24T 1-3/4" Bore with Set Screws, 1200 Systems	-	1
10	AS-0923	Sprocket, #60 18T 1-3/4" Bore with Set Screws, 1700 Systems	-	1
11	AS-0929	Chain, Roller #60 56 Pitch (42") 700 and 1200 Systems	1	-
11	AS-0930	Chain, Roller #60 52 Pitch (39")	-	1
12	MTR-0184	Motor, 1 HP 1 PH 1725 RPM, 60 HZ 115/230V 56C Frame	1	1
12	FLX-3550	Motor, 1 HP 3 PH 1725 RPM, 60 HZ 208-230/460V 56C Frame	1	1
13	MS0062	Cap, Plastic 4" I.D. Tube Orange	2	-
13	MS0063	Cap, Plastic 5" I.D. Tube Orange	-	2
14	S-968	Flange Nut 3/8"-16 ZN Grade 5 Wide Flange	12	16
15	S-1054	Split Lock Washer 3/8" ZN	4	4
16	S-2120	Flat Washer 1/2" SAE ZN	8	8
17	S-3611	Flange Nut 5/16"-18 YDP Grade 2	4	4
18	S-4513	Key, 1/4" x 1/4" x 2" Stock for Shaft	1	1
19	S-8135	Flange Bolt 5/16"-18 x 1-1/4" ZN Grade 5	4	4
20	S-9062	Flange Bolt 1/2"-13 x 1-1/4" ZN Grade 5	8	8
21	S-9064	Flange Bolt 3/8"-16 x 1-1/2" ZN Grade 5 Full Thread	12	16
22	S-9065	Flange Bolt 3/8"-16 x 1" ZN Grade 5	12	16
23	S-9179	Square Key 3/8" x 1-3/4"	1	1
24	301L0003	Decal, Rotation	1	1

# Airlock Inlet Transition Assembly

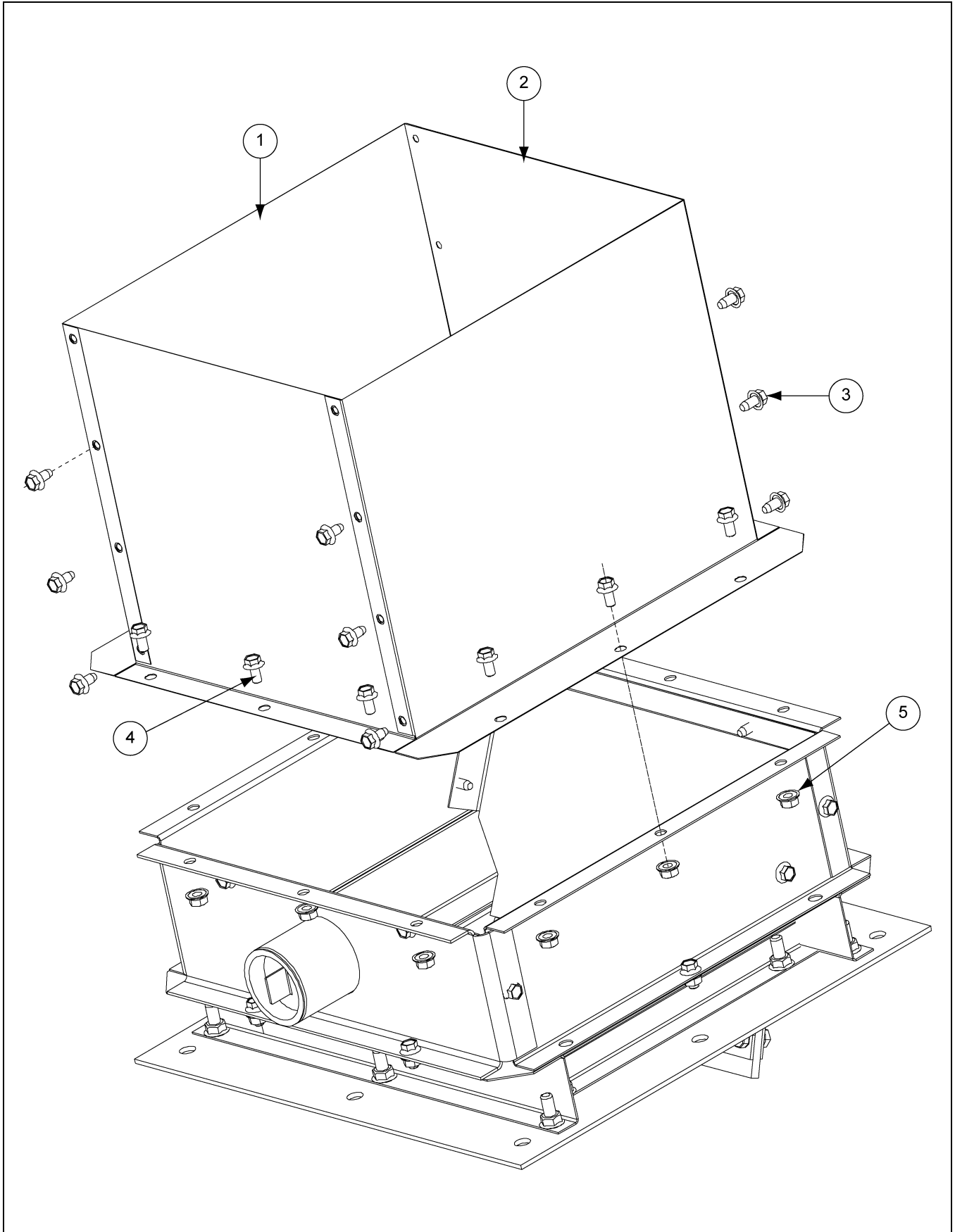

### Airlock Inlet Transition Assembly Parts List

Ref #	Part #	Description	Qty
1	AS-0077	Airlock Inlet Transition - R.H. and L.H.	2
2	AS-0078	Airlock Transition - Front and Back	2
3	S-9028	Screw, SMSAB 1/4"-14 x 1/2" HWH ZN	12
4	S-8857	Flange Bolt 1/4"-20 x 1/2" ZN Grade 5	10
5	S-7215	Flange Nut 1/4"-20 ZN	10

#### Installation of Airlock Transition to Dryer Discharge

1. Remove the weather cover from the airlock inlet assembly.
2. Assemble two (2) AS-0077 ([Ref #1](#)) and (2) AS-0078 ([Ref #2](#)) together with S-9028 ([Ref #3](#)) self-tapper screws as shown [on Page 54](#).
3. Determine what direction the airlock grain line is to run. Orient the transition assembly to correspond with the line direction. Attach the transition assembly to the airlock inlet using S-8857 ([Ref #4](#)) and S-7215 ([Ref #5](#)).
4. Trim the top of the transition assembly to match the height of the dryer discharge.

# 4" and 5" Air Selector Valve

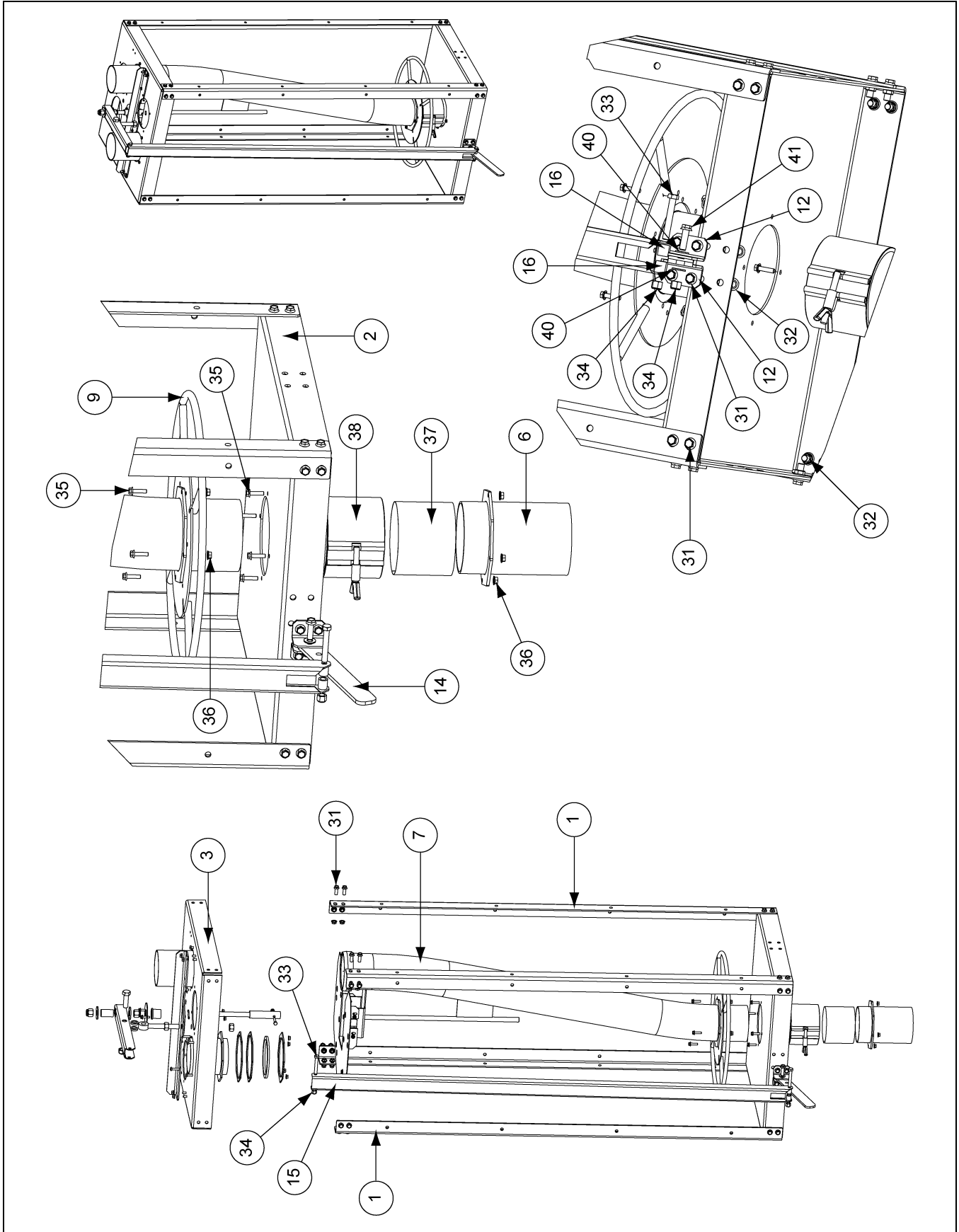



## 4" and 5" Air Selector Valve Parts List

Ref #	Part #	Description	Qty	
			4"	5"
1	401-4803-3	CA-Select Frame Leg Angle 4" and 5"	4	4
2	401-4807-4	CA-Select Base - Input 4" and 5"	1	1
3	401-4806-6	CA-Select Base - Output 4" and 5"	1	1
4	406-2287-0	CA-Select Bearing - Bronze Reamed	1	1
5	401-4815-7	CA-Select Retainer - Bearing 4"-6"	1	1
6	410-1991-BS	CA-Select Inlet Tube Weld 5" - Bin Silver	-	1
6	410-2009-BS	CA-Select Inlet Tube Weld 4" - Bin Silver	1	-
7	410-1988-Y	CA-Select Offset Tube Weld 5" Ochre	-	1
7	410-2011-Y	CA-Select Offset Tube Weld 4" Ochre	1	-
8	410-1989-4	CA-Select Center Shaft Pivot Weld	1	1
9	410-1990-Y	CA-Select Handwheel Weldment	1	1
10	025-1198-8	Threaded Swing Bolt Zinc	1	1
11	401-4888-4	CA-Select Stiffener - 4" and 5"	1	1
12	401-4897-5	CA-Select Bracket - Lever - 4" and 5"	2	2
13	401-4898-3	CA-Select Linkage - Pivot - 4" and 5"	1	1
14	406-2235-9-BS	CA-Select Lever Handle - Bin Silver	1	1
15	401-4899-1	CA-Select Linkage - 4" and 5"	1	1
16	406-2238-3	CA-Select Spacer - Hand Lever 4"-6"	2	2
17	406-2226-8	CA-Select Pivot Linkage Spacer	2	2
18	410-1992-BS	CA-Select Output Tube Weld 5" - Bin Silver	-	2
18	410-2010-BS	CA-Select Output Tube Weld 4" - Bin Silver	2	-
19	401-4810-8	CA-Select Gasket Spacer Ring 5"	-	4
19	401-4895-9	CA-Select Gasket Spacer Ring 4"	4	-
20	802A048	Gasket - 6" O.D. x 4.94" I.D. Special	-	2
20	801A086	Gasket - 5" O.D. x 3.94" I.D. Special	2	-
21	401-4811-6	CA-Select Gasket Retainer Ring 5"	-	2
22	401-4891-8	CA-Select Cover - Outlet - 4" and 5"	1	1
23	406-2239-1	CA-Select Pivot Shaft Spacer Zinc	1	1
24	S-858	Flat Washer 5/8" USS ZN Grade 2	2	2
25	S-8349	Nylock Nut 5/8"-11 ZN Grade 2	2	2
26	S-4329	Bolt, HHCS 5/8"-11 x 2" YDP Grade 8 or Grade 8.2	1	1
27	S-8606	Stover Nut 5/8"-11 ZN Grade C	1	1
28	S-4110	Hex Nut 5/8"-11 YDP Grade 5	2	2
29	S-8997	Bolt, HHCS 1/4"-20 x 1-1/2" ZN Grade 5	1	1
30	2FH0542	Screw, TCSF 1/4"-20 x 1/2" HWHS Zinc	4	4
31	S-9065	Flange Bolt 3/8"-16 x 1" ZN Grade 5	36	36
32	S-968	Flange Nut 3/8"-16 ZN Grade 5 Wide Flange	36	36
33	S-6762	Bolt, HHCS 3/8"-16 x 2-1/2" ZN Grade 5	2	2
34	S-7383	Nylock Nut 3/8"-16 ZN Grade 5	3	3
35	S-9063	Flange Bolt 1/4"-20 x 1" ZN Grade 5	14	14
36	S-7215	Flange Nut 1/4"-20 Zinc	22	22
37	401-4889-2	CA-Select Liner - Coupling 5"	-	1
37	401-4904-9	CA-Select Liner - Coupling 4"	1	-
38	069-1275-2	Coupling 5 Quick - Morris Grip	-	1
38	069-1281-0	Coupling 4 Quick - Morris Grip	1	-
39	S-6997	Bolt, HHCS 1/4"-20 x 1-1/4" ZN Grade 5	8	8
40	S-7409	Flat Washer 3/8" SAE ZN Grade 2	2	2
41	S-9066	Flange Bolt 3/8"-16 x 1-1/4" ZN Grade 5	1	1
42	S-7025	Nylock Nut 1/4"-20 ZN Grade 5	1	1

4" and 5" Air Selector Valve (Continued)

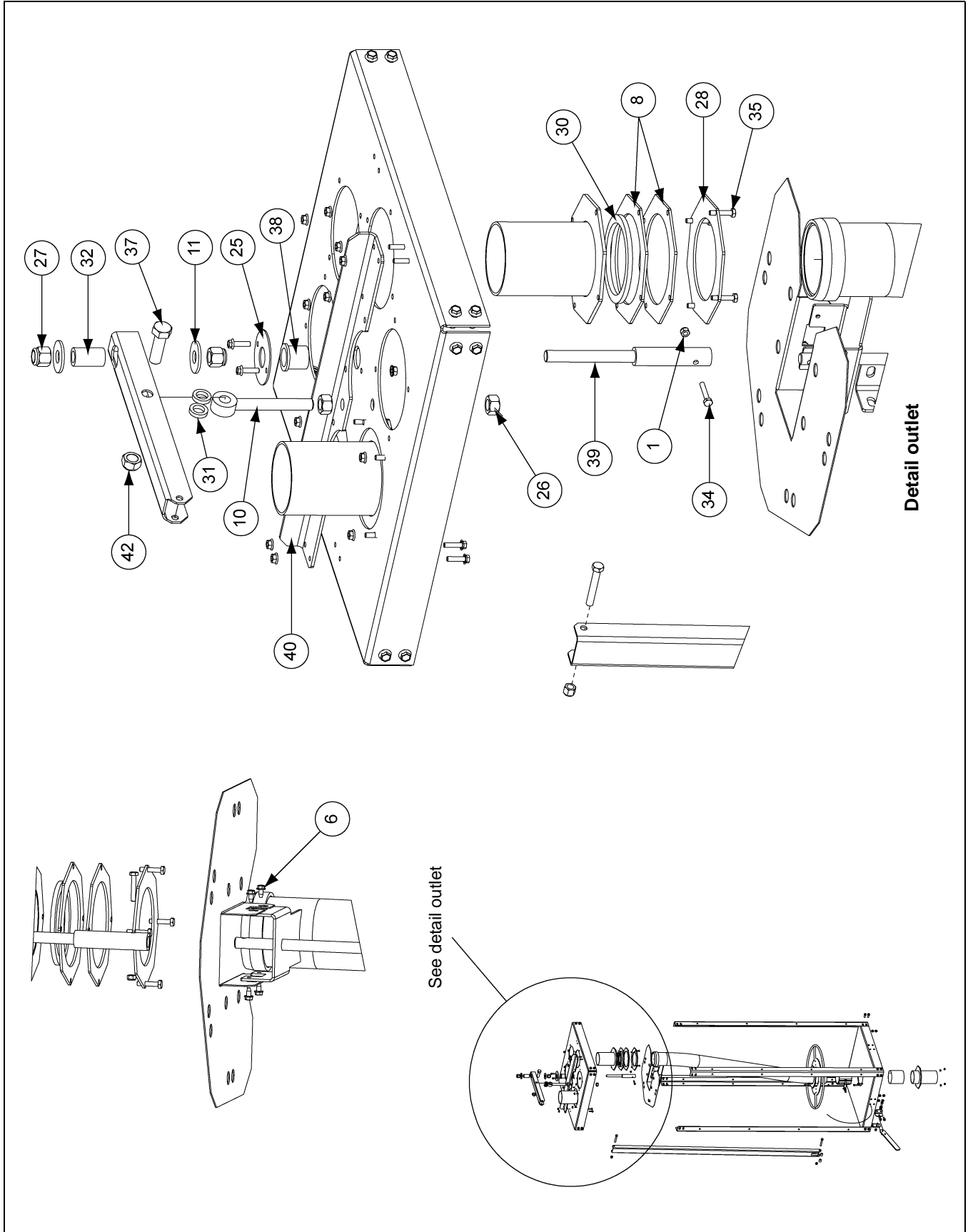

## 4" and 5" Air Selector Valve Parts List

Ref #	Part #	Description	Qty	
			4"	5"
1	S-7025	Nylock Nut 1/4"-20 ZN Grade 5	1	1
2	069-1281-0	Coupling - 4 Quick - Morris Grip	1	-
2	069-1275-2	Coupling - 5 Quick - Morris Grip	-	1
3	S-968	Flange Nut 3/8"-16 ZN Grade 5 Wide Flange	36	36
4	S-7215	Flange Nut 1/4"-20 ZN	22	22
5	S-9063	Flange Bolt 1/4"-20 x 1" ZN Grade 5	14	14
6	2FH0542	Screw, TCSF 1/4"-20 x 1/2" HWHS ZN	4	4
7	S-9065	Flange Bolt 3/8"-16 x 1" ZN Grade 5	36	36
8	S-9066	Flange Bolt 3/8"-16 x 1-1/4" ZN Grade 5	1	1
9	S-7409	Flat Washer 3/8" SAE ZN Grade 2	2	2
10	025-1198-8	Threaded Swing Bolt Zinc 5/8"-11 UNC x 5" Zinc	1	1
11	S-858	Flat Washer 5/8" USS ZN Grade 2	2	2
12	401-4807-4	CA-Select Base - Input 4" and 5"	1	1
13	401-4806-6	CA-Select Base - Output 4" and 5"	1	1
14	401-4897-5	CA-Select Bracket - Lever 4" and 5"	2	2
15	401-4891-8	CA-Select Cover - Outlet 4" and 5"	1	1
16	401-4803-3	CA-Select Frame Leg Angle 4" and 5"	4	4
17	410-1990-Y	CA-Select Handwheel Weldment Ochre	1	1
18	410-2009-BS	CA-Select Inlet Tube Weld 4" - Bin Silver	1	-
18	410-1991-BS	CA-Select Inlet Tube Weld 5" - Bin Silver	-	1
19	406-2235-9-BS	CA-Select Lever Handle - Bin Silver	1	1
20	401-4904-9	CA-Select Liner - Coupling - 4"	1	-
20	401-4889-2	CA-Select Liner - Coupling - 5"	-	1
21	401-4899-1	CA-Select Linkage - 4" and 5"	1	1
22	401-4898-3	CA-Select Linkage - Pivot - 4" and 5"	1	1
23	410-2011-Y	CA-Select Offset Tube Weld 4" Ochre	1	-
23	410-1988-Y	CA-Select Offset Tube Weld 5" Ochre	-	1
24	410-2010-BS	CA-Select Output Tube Weld 4" - Bin Silver	2	-
24	410-1992-BS	CA-Select Output Tube Weld 5" - Bin Silver	-	2
25	401-4815-7	CA-Select Retainer - Bearing 4"-6"	1	1
26	S-4110	Hex Nut 5/8"-11 YDP Grade 5	2	2
27	S-8349	Nylock Nut 5/8"-11 ZN Grade 2	2	2
28	401-4896-7	CA-Select Gasket Retainer Ring 4"	2	-
28	401-4811-6	CA-Select Gasket Retainer Ring 5"	-	2
29	401-4895-9	CA-Select Gasket Spacer Ring 4"	4	-
29	401-4810-8	CA-Select Gasket Spacer Ring 5"	-	4
30	801A086	Gasket - 5" O.D. x 3.94" I.D. Special	2	-
30	802A048	Gasket - 6" O.D. x 4.94" I.D. Special	-	2
31	406-2226-8	CA-Select Pivot Linkage Spacer Zinc Plated	2	2
32	406-2239-1	CA-Select Pivot Shaft Spacer Zinc Plated	1	1
33	406-2238-3	CA-Select Spacer-Hand Lever 4"-6" Zinc Plated	2	2
34	S-8997	Bolt, HHCS 1/4"-20 x 1-1/2" ZN Grade 5	1	1
35	S-6997	Bolt, HHCS 1/4"-20 x 1-1/4" ZN Grade 5	8	8
36	S-6762	Bolt, HHCS 3/8"-16 x 2-1/2" ZN Grade 5	2	2
37	S-4329	Bolt, HHCS 5/8"-11 x 2" YDP Grade 8 or Grade 8.2	1	1
38	406-2287-0	CA-Select Bearing - Bronze Reamed	1	1
39	410-1989-4	CA-Select Center Shaft Pivot Weld	1	1
40	401-4888-4	CA-Select Stiffener - 4" and 5"	1	1
41	S-7383	Nylock Nut 3/8"-16 ZN Grade 5	3	3
42	S-8606	Stover Nut 5/8"-11 ZN Grade C	1	1

## 12. Parts List

### 4" and 5" Deadhead Deflector Assembly for 90° Spout

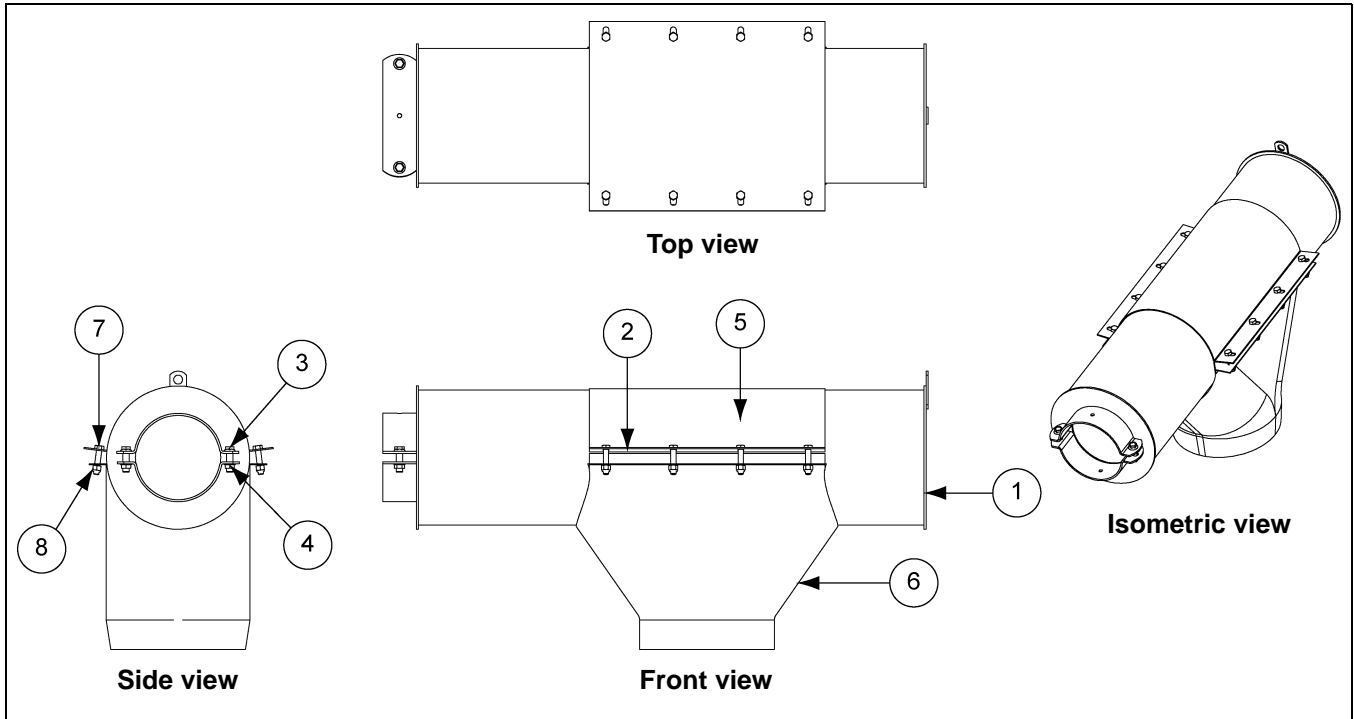

#### 4" and 5" Deadhead Deflector Assembly Parts List

Ref #	Part #	Description	Qty	
			4"	5"
1	8021115-BS	Deadhead Deflector Weld - 5" Bin Silver	-	1
1	8011225-BS	Deadhead Deflector Weld - 4" Bin Silver	1	-
2	MS0068-802A025	Gasket for 5" Deadhead	-	1
2	MS0068	Foam, Neoprene, ADH. BK 1/4" x 1" x 50' is Bulk Purch. STR	1	-
3	S-9066	Flange Bolt 3/8"-16 x 1-1/4" ZN Grade 5	2	2
4	S-968	Flange Nut 3/8"-16 ZN Grade 5 Wide Flange	2	2
5	GK1505	Band: Half 8" x 14" 14 Gauge Galvanized	-	1
5	GK1125	Band: Half 6" x 10" 16 Gauge Galvanized	1	-
6	GK3394	Spout: 8" 90° Weldment	-	1
6	GK3382	Spout: 6" 90° Weldment	1	-
7	S-3675	Bolt, HHTB 5/16"-18 x 1-1/2" ZN Grade 5	6	8
8	S-7382	Nylock Nut 5/16"-18 ZN Grade 5	6	8

## 4" and 5" Deadhead Deflector Assembly for 60° Spout

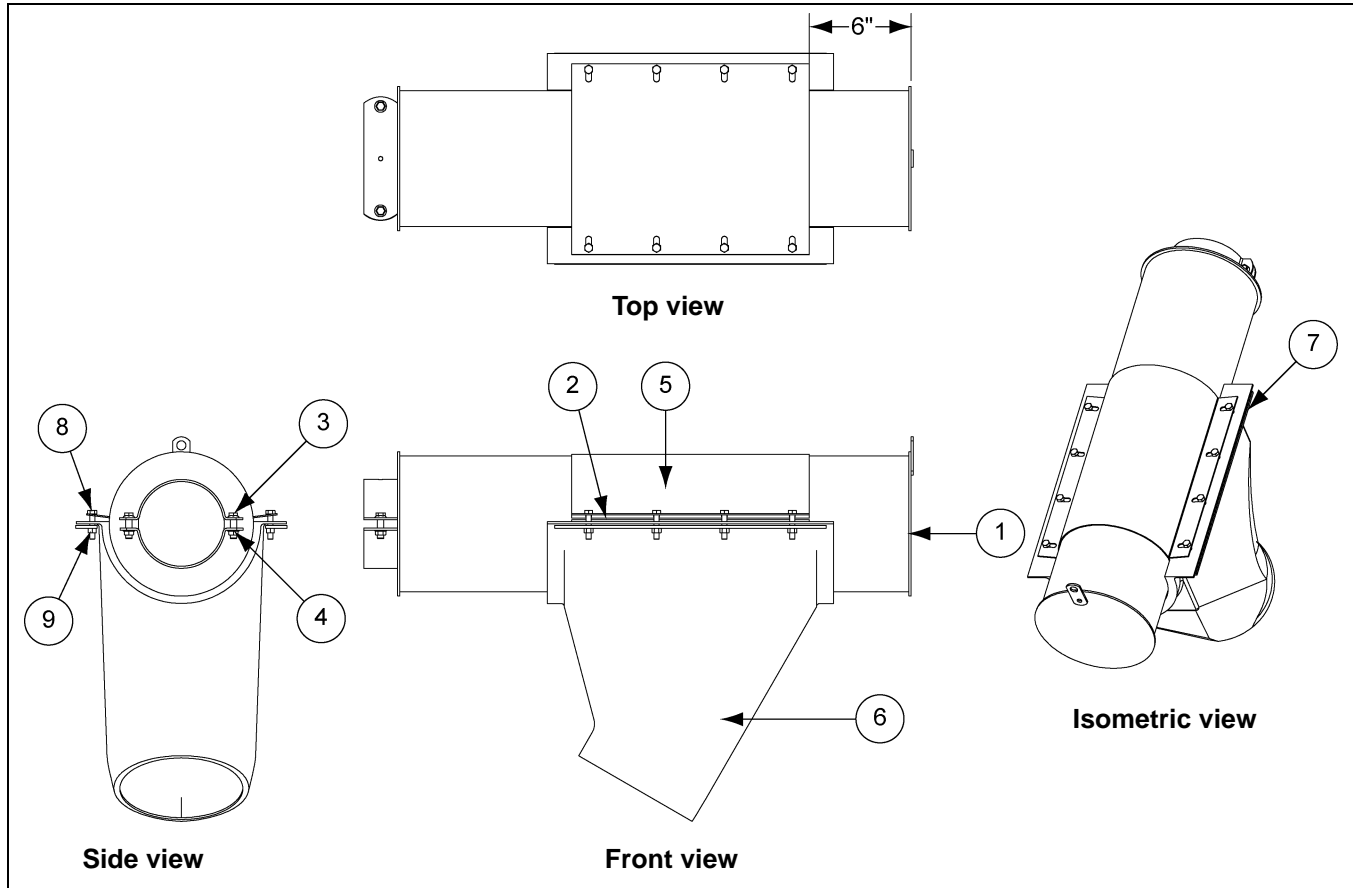

### 4" and 5" Deadhead Deflector Assembly for 60° Spout Parts List

Ref #	Part #	Description	Qty	
			4"	5"
1	8021115-BS	Deadhead Deflector Weld - 5" Bin Silver	-	1
1	8011225-BS	Deadhead Deflector Weld - 4" Bin Silver	1	-
2	MS0068-802A025	Gasket for 5" Deadhead	1	-
2	MS0068	Foam, Neoprene, ADH. BK 1/4" x 1" x 50' is Bulk Purch. STR	-	1
3	S-9066	Flange Bolt 3/8"-16 x 1-1/4" ZN Grade 5	2	2
4	S-968	Flange Nut 3/8"-16 ZN Grade 5	2	2
5	GK1505	Band: Half 8" x 14" 14 Gauge Galvanized	-	1
5	GK1125	Band: Half 6" x 10" 16 Gauge Galvanized	1	-
6	GK80319	Spout, Plastic 8" 60° Black	-	1
6	GK80321	Spout, Plastic 6" 60° Black	1	-
7	GK3237	Spout, 8" Support Strap	-	2
7	GK3449	Spout, 6" Support Strap	2	-
8	S-3675	Bolt, HHTB 5/16"-18 x 1-1/2" ZN Grade 5	6	8
9	S-7382	Nylock Nut 5/16"-18 ZN Grade 5	6	8

## 4" and 5" Valve Assembly

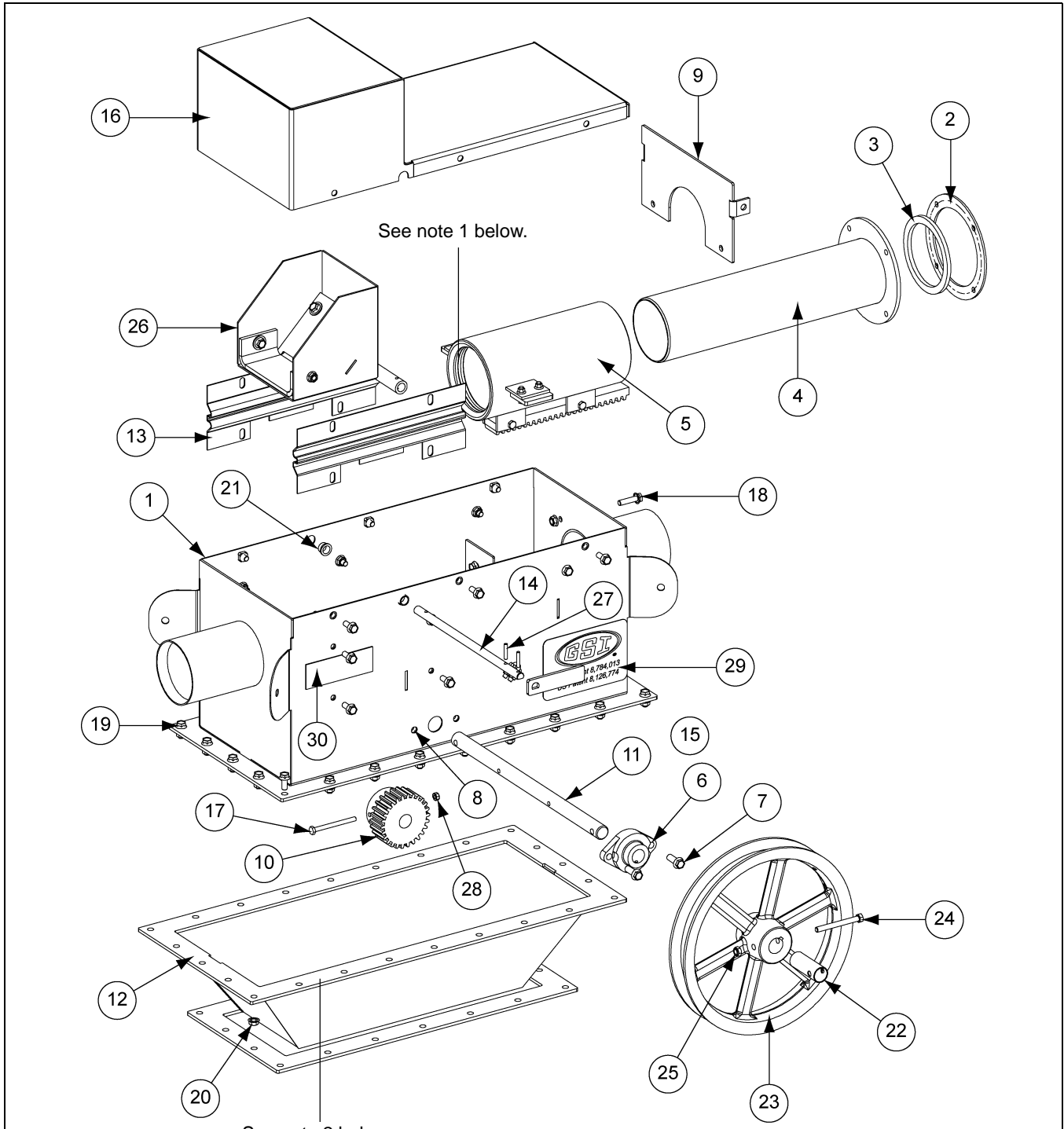

Exploded view

**NOTES:**

1. Coat O-rings four (4) with IMS 3% silicone spray mold release prior to installing onto AS-0859 (IMS #113653).
2. S-4458 Caulk to be used to inside of hole pattern around perimeter (approximately 6').

## 4" and 5" Valve Assembly Parts List

Ref #	Part #	Description	Qty	
			4"	5"
1	AS-0858-BS	Valve - Housing Weld 4" Painted - Bin Silver	1	-
1	AS-0626-BS	Valve - Housing Weld 5" Painted - Bin Silver	-	1
2	AS-0863-BS	Valve - Seal Spacer 4" - Bin Silver	1	-
2	AS-0613-BS	Valve - Seal Spacer 5" - Bin Silver	-	1
3	801A086	Gasket - 5" O.D. x 3.94" I.D.	1	-
3	802A048	Gasket - 6" O.D. x 4.94" I.D. Special	-	1
4	AS-0859	Valve - Core Tube Weld 4"	1	-
4	AS-0606	Valve - Core Tube Weld 5"	-	1
5	AS-0860	Valve - Sleeve Assembly 4"	1	-
5	AS-0629	Valve - Sleeve Assembly 5"	-	1
6	S-8030	Bearing, 7/8" 2 - Belt Flange	2	2
7	S-9065	Flange Bolt 3/8"-16 x 1" ZN Grade 5	4	4
8	S-968	Flange Nut 3/8"-16 ZN Grade 5 Wide Flange	4	4
9	AS-0870-BS	Valve - Core Tube Clamp 4" Painted - Bin Silver	1	-
9	AS-0627-BS	Valve - Core Tube Clamp 5" Painted - Bin Silver	-	1
10	S-8129	SPUR Gear 8DP 26 Tooth 7/8" Bore	1	1
11	AS-0517	Pinion Shaft - 5" Deadhead Valve	1	1
12	AS-0666-BS	Valve - Spout Weld Painted - Bin Silver	1	1
13	AS-0792-BS	Valve - Sleeve Guide - Bin Silver	2	2
14	AS-0607	Valve - Deflector Shaft	1	1
15	AS-0612-Y	Valve - Direction Indicator Painted Ochre	1	1
16	AS-0797	Valve - Lid Assembly	1	1
17	S-10172	Bolt, HHCS 1/4"-20 x 3" ZN Grade 5	1	1
18	S-7470	Flange Bolt 5/16"-18 x 1" ZN Grade 5	4	4
19	S-6606	Flange Bolt 5/16"-18 x 3/4" ZN Grade 5	42	42
20	S-3611	Flange Nut 5/16"-18 YDP Grade 2	40	40
21	017-1345-2	Bearing - Bronze Flanged Sleeve FF636-3	2	2
22	8081316	Bushing - Control Wheel Discharge	1	1
23	8101153	Control Wheel, 10" w/Clamp	1	1
24	S-7601	Bolt, HHCS 5/16"-18 x 3" ZN Grade 2	1	1
25	S-7382	Nylock Nut 5/16"-18 ZN Grade 5	1	1
26	AS-0794	Valve Deflector Assembly 5"	1	1
27	S-8169	Spring Pin 3/16" x 1" Plain Steel Slotted Rolled	2	2
28	S-4310	Lock Nut 1/4"-20 ZN Grade 2	1	1
29	DC-2398	Decal, GSI Logo - Patent Pending	2	2
30	DC-113	Decal, Airflow	2	2

## Air System Cyclone Package

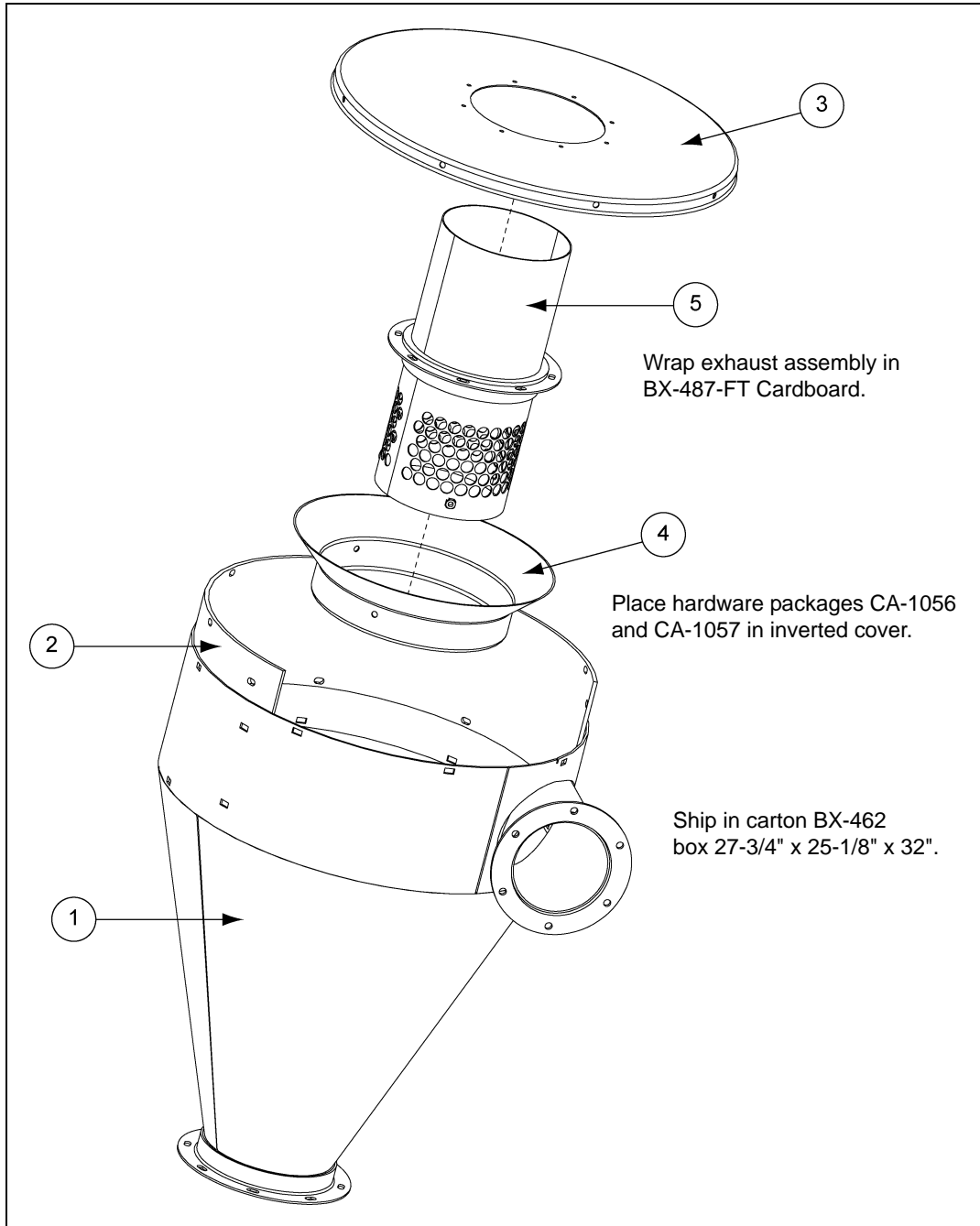

### Air System Cyclone Package Parts List

Ref #	Part #	Description	Qty
1	410-1216-BS	Cyclone Entry Weldment - Bin Silver	1
2	406-1635-1	Wear Liner - A/R Cyclone	1
3	401-1596-BS	Cover - Cyclone - Bin Silver	1
4	401-1600-BS	Rain Hood - A/R Cyclone - Bin Silver	1
5	AS-0105-BS	Cyclone Exhaust Assembly - Bin Silver	1



## Air System Cyclone Package Small

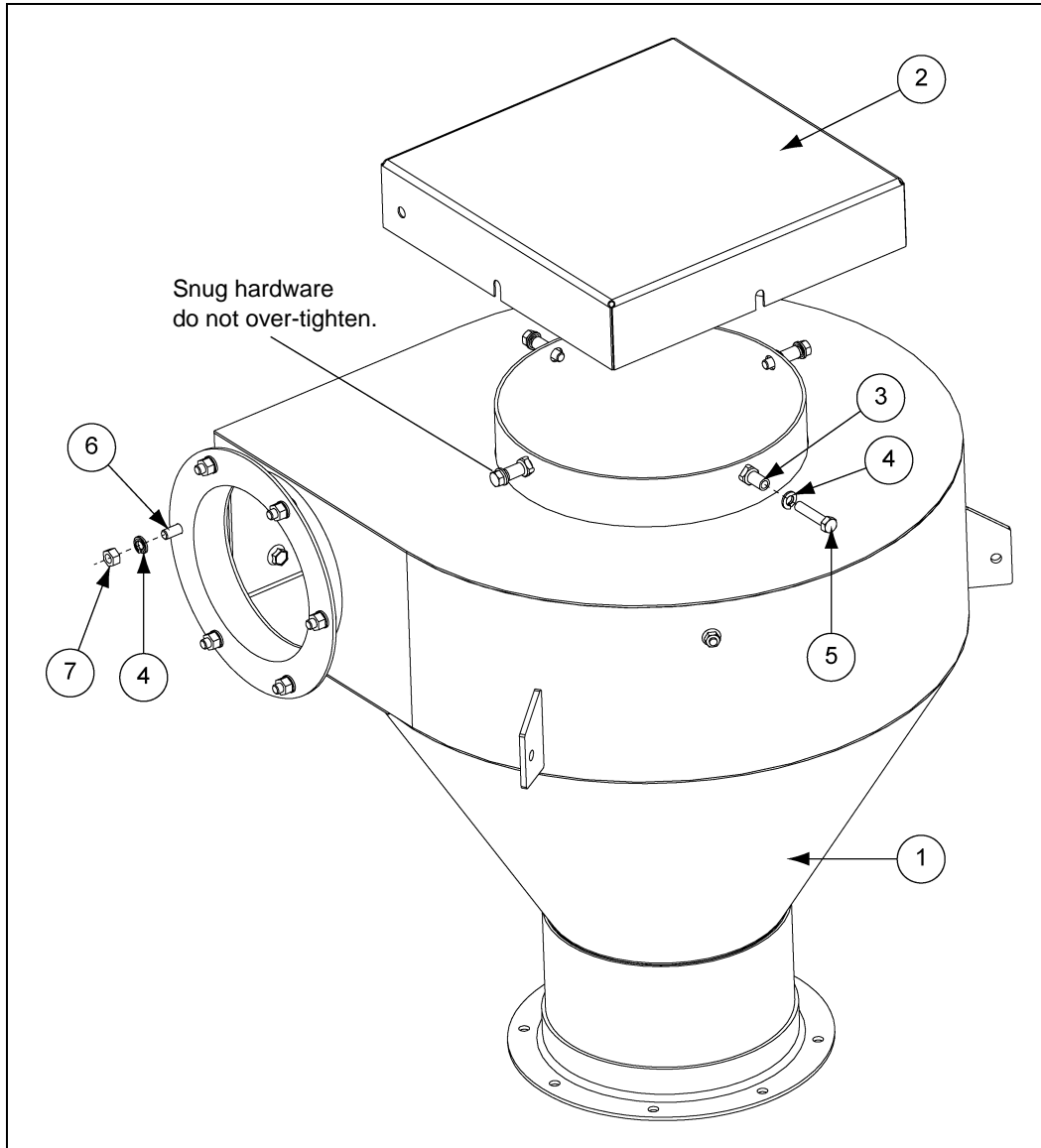

### Air System Cyclone Package Small Parts List

Ref #	Part #	Description	Qty
1	8011224-BS	Cyclone Weld - DMC - Bin Silver	1
2	801A164	Vent Cap - 12" x 12" Galv. DMC Cyclone	1
3	106E073	Standoff - Switch, STR-G	4
4	S-1147	Split Lock Washer 5/16" ZN	10
5	S-2741	Bolt, HHCS 5/16"-18 x 1-1/2" ZN Grade 5	4
6	S-8072	Bolt, HHCS 5/16"-18 x 3/4" ZN Grade 2	6
7	S-396	Hex Nut 5/16"-18 YDP Grade 2	6

## Inner Door Assembly - Standard

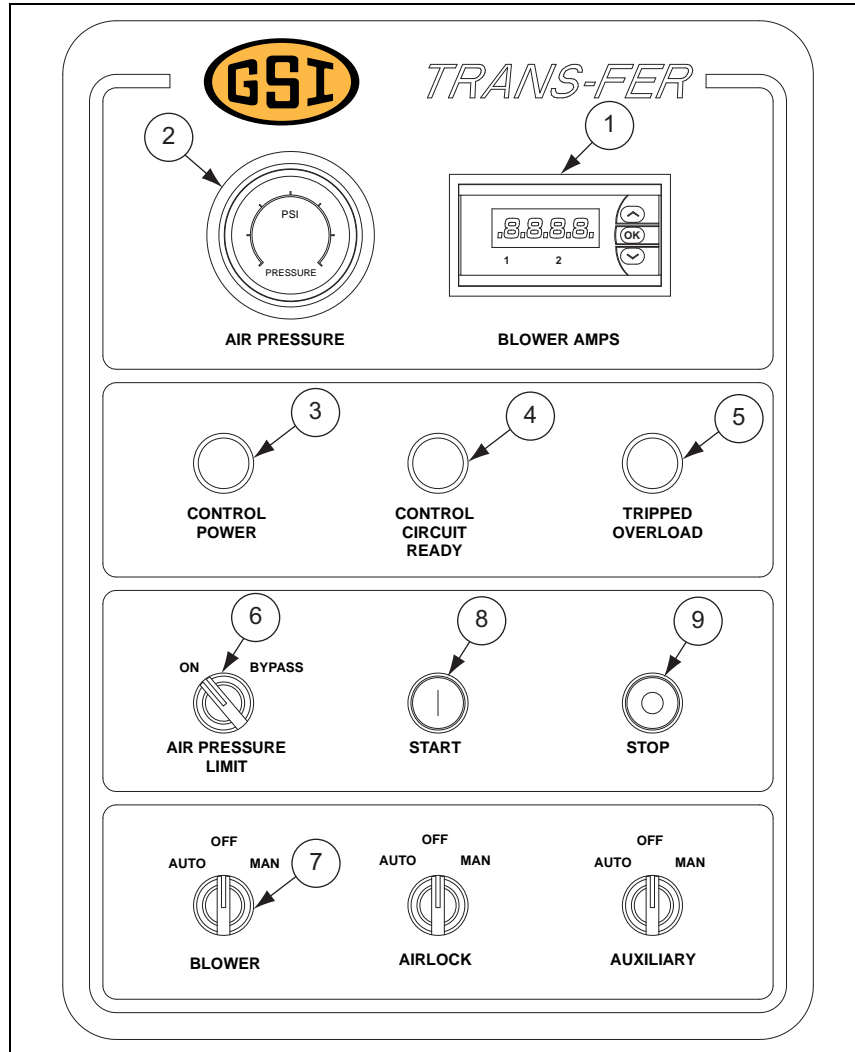

Inner Door Assembly - Standard Parts List

Ref #	Part #	Description	Qty
1	AS-0715	LED Display	1
2	AS-0720	Air Pressure Gauge	1
3	AS-0727	Yellow Pilot Light (Control Power)	1
4	AS-0725	Green Pilot Light (Control Circuit Ready)	1
5	AS-0726	Red Pilot Light (Tripped Overload)	1
6	AS-0719	2 Position Selector Switch (Air Pressure Override)	1
7	AS-0724	3 Position Selector Switch (Motor Selector Switch)	3
8	AS-0717	22 mm Push Button Operator - Green (Start)	1
9	AS-0718	22 mm Push Button Operator - Red (Stop)	1
N/S	AS-0721	40 mm Enable/Disable Stop	1
N/S	4FH1122	Hose Barb - 1/4" Hose	1
N/S	4FH0452	Street Elbow	1
N/S	AS-0763	Hose, 1/4" I.D. x 4' Long	1

## Inner Door Assembly - Twin

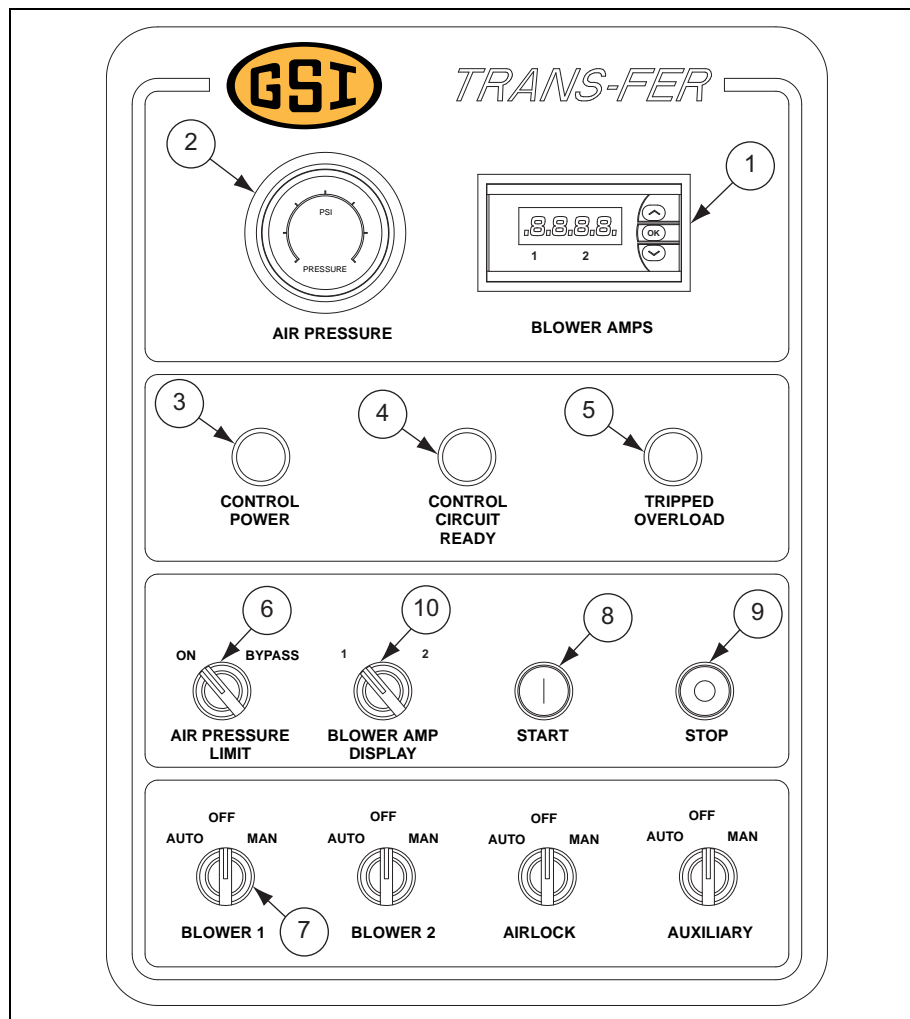

### Inner Door Assembly - Twin Parts List

Ref #	Part #	Description	Qty
1	AS-0715	LED Display	1
2	AS-0720	Air Pressure Gauge	1
3	AS-0727	Yellow Pilot Light (Control Power)	1
4	AS-0725	Green Pilot Light (Control Circuit Ready)	1
5	AS-0726	Red Pilot Light (Tripped Overload)	1
6	AS-0719	2 Position Selector Switch (Air Pressure Override)	1
7	AS-0724	3 Position Selector Switch (Motor Selector Switch)	4
8	AS-0717	22 mm Push Button Operator - Green (Start)	1
9	AS-0718	22 mm Push Button Operator - Red (Stop)	1
10	AS-0734	2 Position Maintained Selector Switch	1
N/S	AS-0721	40 mm Enable/Disable Stop	1
N/S	4FH1122	Hose Barb - 1/4" Hose	1
N/S	4FH0452	Street Elbow	1
N/S	AS-0763	Hose - 1/4" I.D. x 4' Long	1

## 12. Parts List

### Standard Control Panel Assembly 230V - 1 Phase

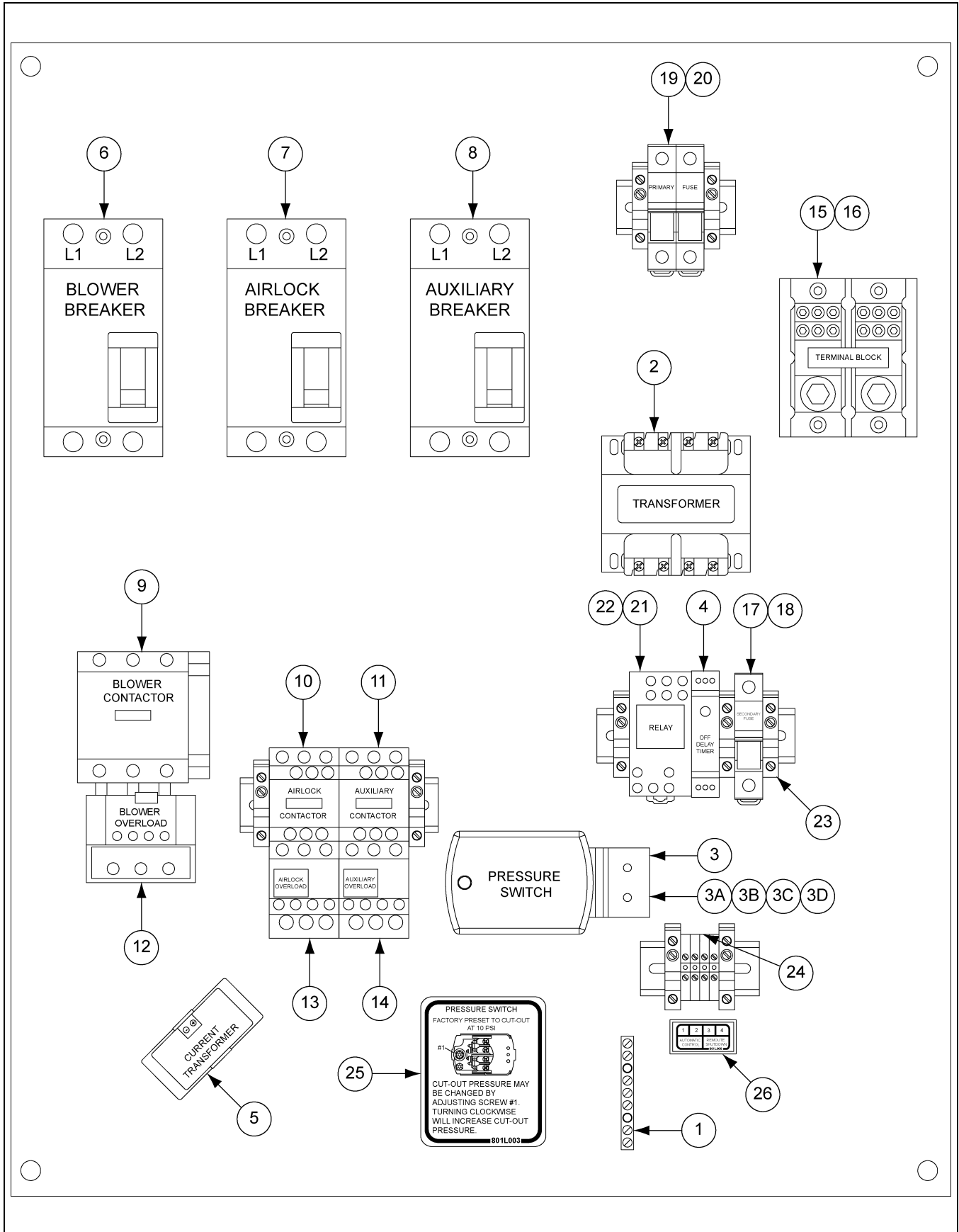

## Standard Control Panel Assembly 230V - 1 Phase Parts List

Ref #	Part #	Description	Qty	
			AS-0669 10 HP	AS-0670 15 HP
1	AS-0730	Ground Bar Kit	1	1
2	2EL0308	240/480P 120/240S Control Transformer	1	1
3	AS-0760	Switch Assembly - High Pressure (Set at 10 PSI)	1	1
3A	801E019	Switch - Pressure (Preset at 10 PSI)	1	1
3B	801E050	Bracket - Pressure Switch	1	1
3C	4FH1465	Tee, Fit - Pipe (PVC) 1/4" x 1/4" x 1/4"	1	1
3D	S-1158	Screw, TCSF #8-32 x 1/2" PHP ZN	2	2
4	AS-0716	Off/Delay Timer 250V 0.7A RE11 + Options	1	1
5	AS-0736	Current Transducer	1	1
6	D03-0926	2P - 240V - 90A Circuit Breaker	1	-
6	D03-0927	2P - 240V - 100A Circuit Breaker	-	1
7	AS-0733	240V 35A Circuit Breaker	1	1
8	D03-0919	2P - 240V - 15A Circuit Breaker	1	1
9	056-1994-5A	65A 110V Contactor	1	-
9	056-2030-7	80A 110V Contactor	-	1
10	056-1949-9	18A 110V Contactor	1	1
11	056-1942-4	12A 110V Contactor	1	1
12	AS-0752	37-50A Overload	1	-
12	AS-0757	48-65A Overload	-	1
13	C-8693	5.5-8A Overload Relay	1	1
14	C-8694	7-10A Overload Relay	1	1
15	AS-0738	Power Distribution Block 175A 600V 2 Pole	1	-
15	AS-0740	Power Distribution Block 335A 600V 2 Pole	-	1
16	AS-0739	Clear Distribution Block Cover	1	1
17	AS-0728	2 Amp 600V Special Purpose Fuse	1	1
18	AS-0731	Fuse Holder 600V 30 Amp 1 Pole, CC Fuse	1	1
19	AS-0729	1 Amp 600V CC TD Fuse	2	2
20	AS-0732	Fuse Holder 600V 30 Amp 2 Pole, CC Fuse	1	1
21	AS-0722	Relay	1	1
22	AS-0723	Relay - Socket	1	1
23	AS-0758	End Clamp	11	11
24	AS-0759	Terminal Block	4	4
25	801L003	Decal - Pressure Switch	1	1
26	801L006	Decal - Terminal Strip	1	1

# Twin Control Panel Assembly 230V - 1 Phase

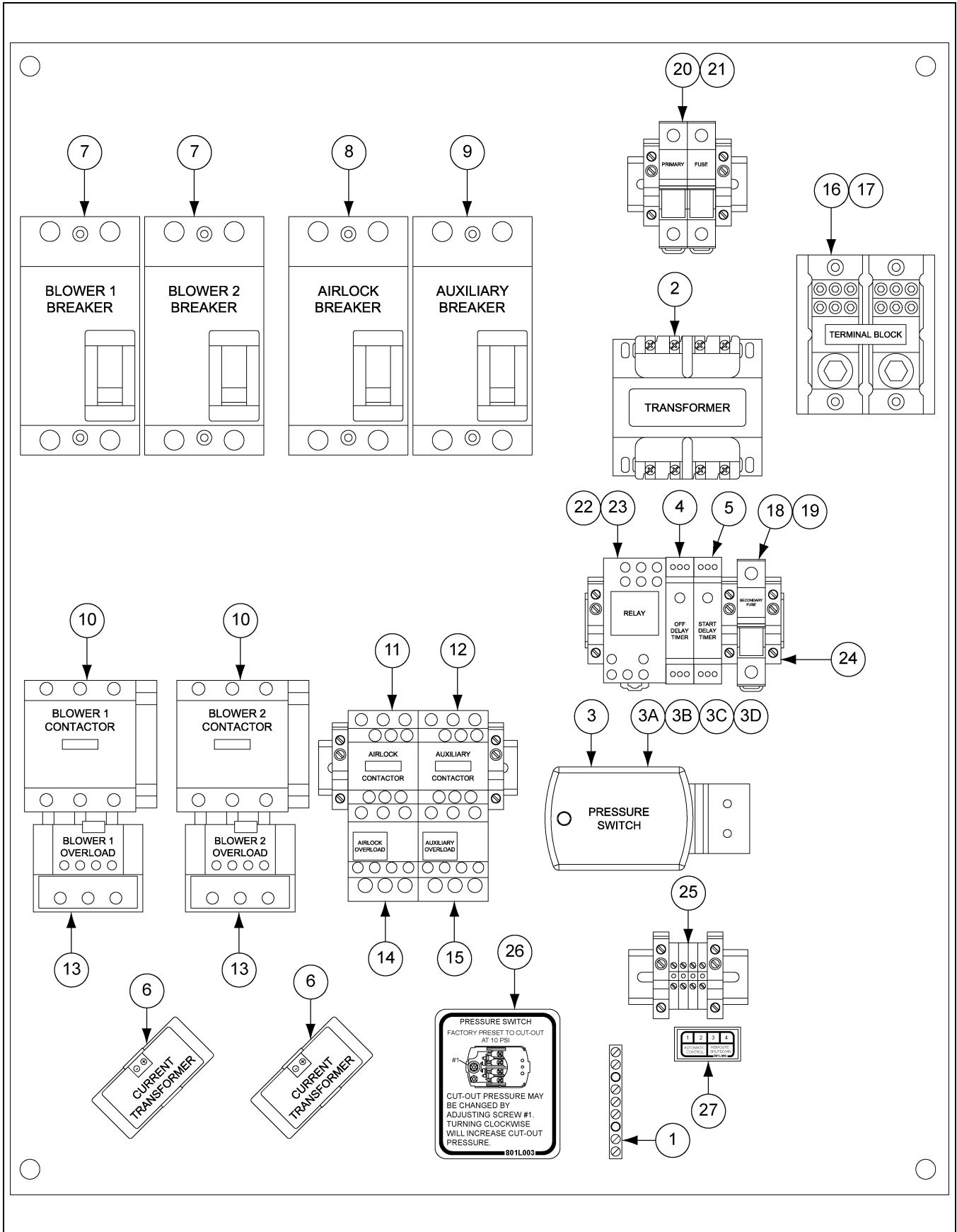

## Twin Control Panel Assembly 230V - 1 Phase Parts List

Ref #	Part #	Description	Qty	
			AS-0667 10 HP	AS-0668 15 HP
1	AS-0730	Ground Bar Kit	1	1
2	2EL0308	240/480P 120/240S Control Transformer	1	1
3	AS-0760	Switch Assembly - High Pressure (Set at 10 PSI)	1	1
3A	801E019	Switch - Pressure (Preset at 10 PSI)	1	1
3B	801E050	Bracket - Pressure Switch	1	1
3C	4FH1465	Tee, Fit - Pipe (PVC) 1/4" x 1/4" x 1/4"	1	1
3D	S-1158	Screw, TCSF #8-32 x 1/2" PHP ZN	2	2
4	AS-0716	Off/Delay Timer 250V 0.7A RE11 + Options	1	1
5	AS-0735	Start/Delay Timer 250V 0.7A	1	1
6	AS-0736	Current Transducer	2	2
7	D03-0926	2P - 240V - 90A Circuit Breaker	2	-
7	D03-0927	2P - 240V - 100A Circuit Breaker	-	2
8	AS-0733	240V 35A Circuit Breaker	1	1
9	D03-0919	2P - 240V - 15A Circuit Breaker	1	1
10	056-1994-5A	65A 110V Contactor	2	-
10	056-2030-7	80A 110V Contactor	-	2
11	056-1949-9	18A 110V Contactor	1	1
12	056-1942-4	12A 110V Contactor	1	1
13	AS-0752	37-50A Overload	2	-
13	AS-0757	48-65A Overload	-	2
14	C-8694	7-10A Overload Relay	1	1
15	C-8696	12-18A Overload Relay	1	1
16	AS-0264	Power Distribution Block 335A 600V 2 Pole	1	1
17	AS-0737	Clear Distribution Block Cover	1	1
18	AS-0728	2 Amp 600V Special Purpose Fuse	1	1
19	AS-0731	Fuse Holder 600V 30 Amp 1 Pole, CC Fuse	1	1
20	AS-0729	1 Amp 600V CC TD Fuse	2	2
21	AS-0732	Fuse Holder 600V 30 Amp 2 Pole, CC Fuse	1	1
22	AS-0722	Relay	1	1
23	AS-0723	Relay - Socket	1	1
24	AS-0758	End Clamp	11	11
25	AS-0759	Terminal Block	4	4
26	801L003	Decal - Pressure Switch	1	1
27	801L006	Decal - Terminal Strip	1	1

## 12. Parts List

### Standard Control Panel Assembly 10-40 HP 230V - 3 Phase

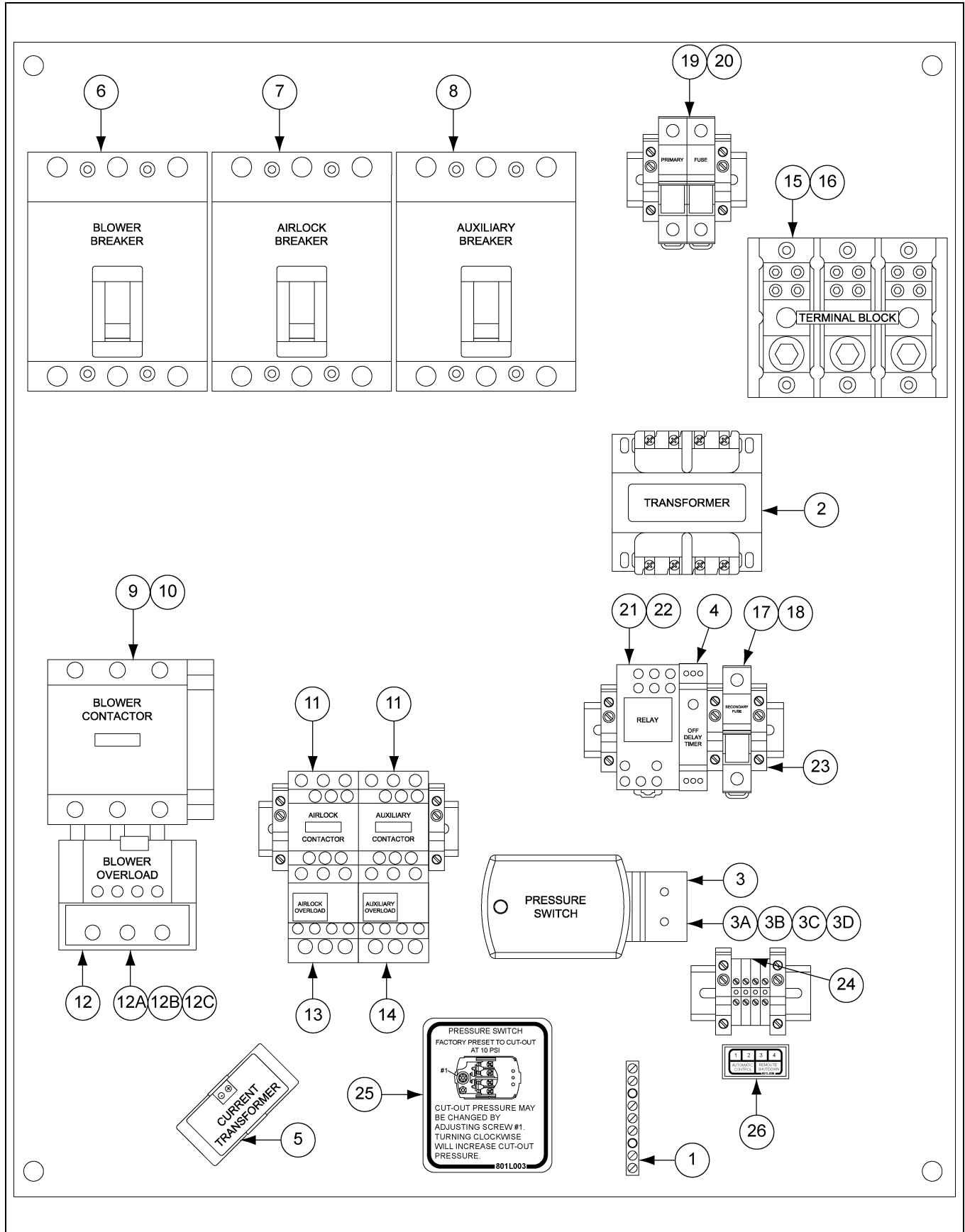



## Standard Control Panel Assembly 10-40 HP 230V - 3 Phase Parts List

Ref #	Part #	Description	Qty				
			AS-0674 10 HP	AS-0675 15 HP	AS-0676 20 HP	AS-0677 30 HP	AS-0671 40 HP
1	AS-0730	Ground Bar Kit	1	1	1	1	1
2	2EL0308	240/480P 120/240S Control Transformer	1	1	1	1	1
3	AS-0760	Switch Assembly - High Pressure (Set at 10 PSI)	1	1	1	1	1
3A	801E019	Switch - Pressure (Preset at 10 PSI)	1	1	1	1	1
3B	801E050	Bracket - Pressure Switch	1	1	1	1	1
3C	4FH1465	Tee, Fit - Pipe (PVC) 1/4" x 1/4" x 1/4"	1	1	1	1	1
3D	S-1158	Screw, TCSF #8-32 x 1/2" PHP ZN	2	2	2	2	2
4	AS-0716	Off/Delay Timer 250V 0.7A RE11 + Options	1	1	1	1	1
5	AS-0736	Current Transducer	1	1	1	1	1
6	D03-0941	3P 240V 60A Circuit Breaker	1	-	-	-	-
6	D03-0942	3P 240V 80A Circuit Breaker	-	1	-	-	-
6	D03-0943	3P 240V 90A Circuit Breaker	-	-	1	-	-
6	D03-0896	3P 600V 125A Circuit Breaker	-	-	-	1	-
6	D03-0897	3P 600V 150A Circuit Breaker	-	-	-	-	1
7	D03-0929	3P 240V 20A Circuit Breaker	1	1	1	1	1
8	D03-0928	3P 240V 15A Circuit Breaker	1	1	1	1	1
9	056-1941-6	32A 110V Contactor	1	-	-	-	-
9	056-2078-6A	50A 110V Contactor	-	1	-	-	-
9	056-1994-5A	65A 110V Contactor	-	-	1	-	-
9	056-2030-7	80A 110V Contactor	-	-	-	1	-
9	AS-0761	115A 600V Contactor	-	-	-	-	1
10	AS-0767	Coil 120V	-	-	-	-	-
10	AS-0768	Coil 120V	-	-	-	-	-
11	056-1942-4	12A 110V Contactor	2	2	2	2	2
12	056-2079-4	25-32A Overload	1	-	-	-	-
12	AS-0752	37-50A Overload	-	1	-	-	-
12	D03-0984	48-65A Overload	-	-	1	-	-
12	CH-1062	63-80A Overload	-	-	-	1	-
12	056-2276-6	90-150A Overload	-	-	-	-	1
12A	GT3-1064	Lug Kit	-	-	-	-	-
12B	GT3-1063	Connector Kit	-	-	-	-	-
12C	GT3-1062	Overload Mount Kit	-	-	-	-	-
13	CH-1052	2.5-4A Overload Relay	1	1	1	1	1
14	CH-1053	4-6A Overload Relay	1	1	1	1	1
15	1EL0911	Power Distribution Block 175A 600V 3 Pole	1	1	1	-	-
15	AS-0743	Power Distribution Block 335A 600V 3 Pole	-	-	-	1	-
15	AS-0745	Power Distribution Block 350A 600V 3 Pole	-	-	-	-	1
16	AS-0742	Clear Distribution Block Cover	1	1	1	-	-
16	AS-0744	Clear Distribution Block Cover	-	-	-	1	1
17	AS-0728	2 Amp 600V Special Purpose Fuse	1	1	1	1	1
18	AS-0731	Fuse Holder 600V 30 Amp 1 Pole, CC Fuse	1	1	1	1	1
19	AS-0729	1 Amp 600V CC TD Fuse	2	2	2	2	2
20	AS-0732	Fuse Holder 600V 30 Amp 2 Pole, CC Fuse	1	1	1	1	1
21	AS-0722	Relay	1	1	1	1	1
22	AS-0723	Relay - Socket	1	1	1	1	1
23	AS-0758	End Clamp	11	11	11	11	11
24	AS-0759	Terminal Block	4	4	4	4	4
25	801L003	Decal - Pressure Switch	1	1	1	1	1
26	801L006	Decal - Terminal Strip	1	1	1	1	1

# 12. Parts List

## Standard Control Panel Assembly 10-40 HP 460V - 3 Phase

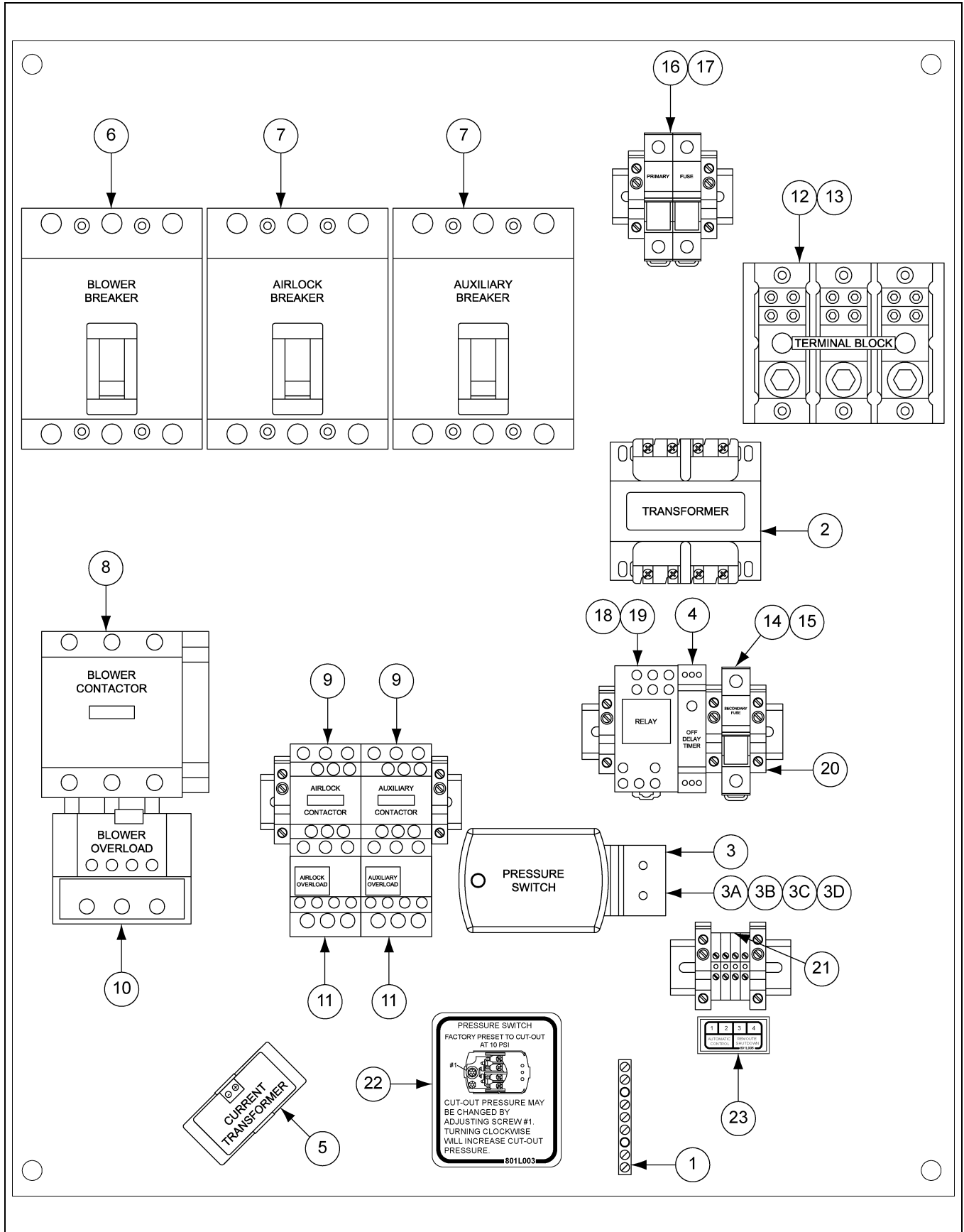

## Standard Control Panel Assembly 10-40 HP 460V - 3 Phase Parts List

Ref #	Part #	Description	Qty				
			AS-0678 10 HP	AS-0679 15 HP	AS-0680 20 HP	AS-0681 30 HP	AS-0682 40 HP
1	AS-0730	Ground Bar Kit	1	1	1	1	1
2	2EL0308	240/480P 120/240S Control Transformer	1	1	1	1	1
3	AS-0760	Switch Assembly - High Pressure (Set at 10 PSI)	1	1	1	1	1
3A	801E019	Switch - Pressure (Preset at 10 PSI)	1	1	1	1	1
3B	801E050	Bracket - Pressure Switch	1	1	1	1	1
3C	4FH1465	Tee, Fit - Pipe (PVC) 1/4" x 1/4" x 1/4"	1	1	1	1	1
3D	S-1158	Screw, TCSF #8-32 x 1/2" PHP ZN	2	2	2	2	2
4	AS-0716	Off/Delay Timer 250V 0.7A RE11 + Options	1	1	1	1	1
5	AS-0736	Current Transducer	1	1	1	1	1
6	AS-0769	3P 480V 25A Circuit Breaker	1	-	-	-	-
6	AS-0771	3P 480V 40A Circuit Breaker	-	1	-	-	-
6	026-1085-5	3P 480V 60A Circuit Breaker	-	-	1	-	-
6	AS-0751	3P 480V 80A Circuit Breaker	-	-	-	1	-
6	026-1040-0	3P 480V 90A Circuit Breaker	-	-	-	-	1
7	AS-0750	3P 480V 15A Circuit Breaker	2	2	2	2	2
8	056-1949-9	18A 110V Contactor	1	-	-	-	-
8	AS-0772	25A 110V Contactor	-	1	-	-	-
8	056-1941-6	32A 110V Contactor	-	-	1	-	-
8	056-2111-5A	40A 110V Contactor	-	-	-	1	-
8	056-1994-5A	65A 110V Contactor	-	-	-	-	1
9	056-1942-4	12A 110V Contactor	2	2	2	2	2
10	056-1944-0	12-18A Overload	1	-	-	-	-
10	056-1943-2	17-25A Overload	-	1	-	-	-
10	056-2079-4	25-32A Overload	-	-	1	-	-
10	AS-0752	37-50A Overload	-	-	-	1	-
10	D03-0984	48-65A Overload	-	-	-	-	1
11	056-1945-7	1.6-2.5A Overload Relay	2	2	2	2	2
12	1EL0911	Power Distribution Block 175A 600V 3 Pole	1	1	1	1	1
13	AS-0742	Clear Distribution Block Cover	1	1	1	1	1
14	AS-0728	2 Amp 600V Special Purpose Fuse	1	1	1	1	1
15	AS-0731	Fuse Holder 600V 30 Amp 1 Pole, CC Fuse	1	1	1	1	1
16	AS-0770	6/10 Amp 600V CC TD Fuse	2	2	2	2	2
17	AS-0732	Fuse Holder 600V 30 Amp 2 Pole, CC Fuse	1	1	1	1	1
18	AS-0722	Relay	1	1	1	1	1
19	AS-0723	Relay - Socket	1	1	1	1	1
20	AS-0758	End Clamp	11	11	11	11	11
21	AS-0759	Terminal Block	4	4	4	4	4
22	801L003	Decal - Pressure Switch	1	1	1	1	1
23	801L006	Decal - Terminal Strip	1	1	1	1	1

# 12. Parts List

## Standard Control Panel Assembly 10-40 HP 575V - 3 Phase

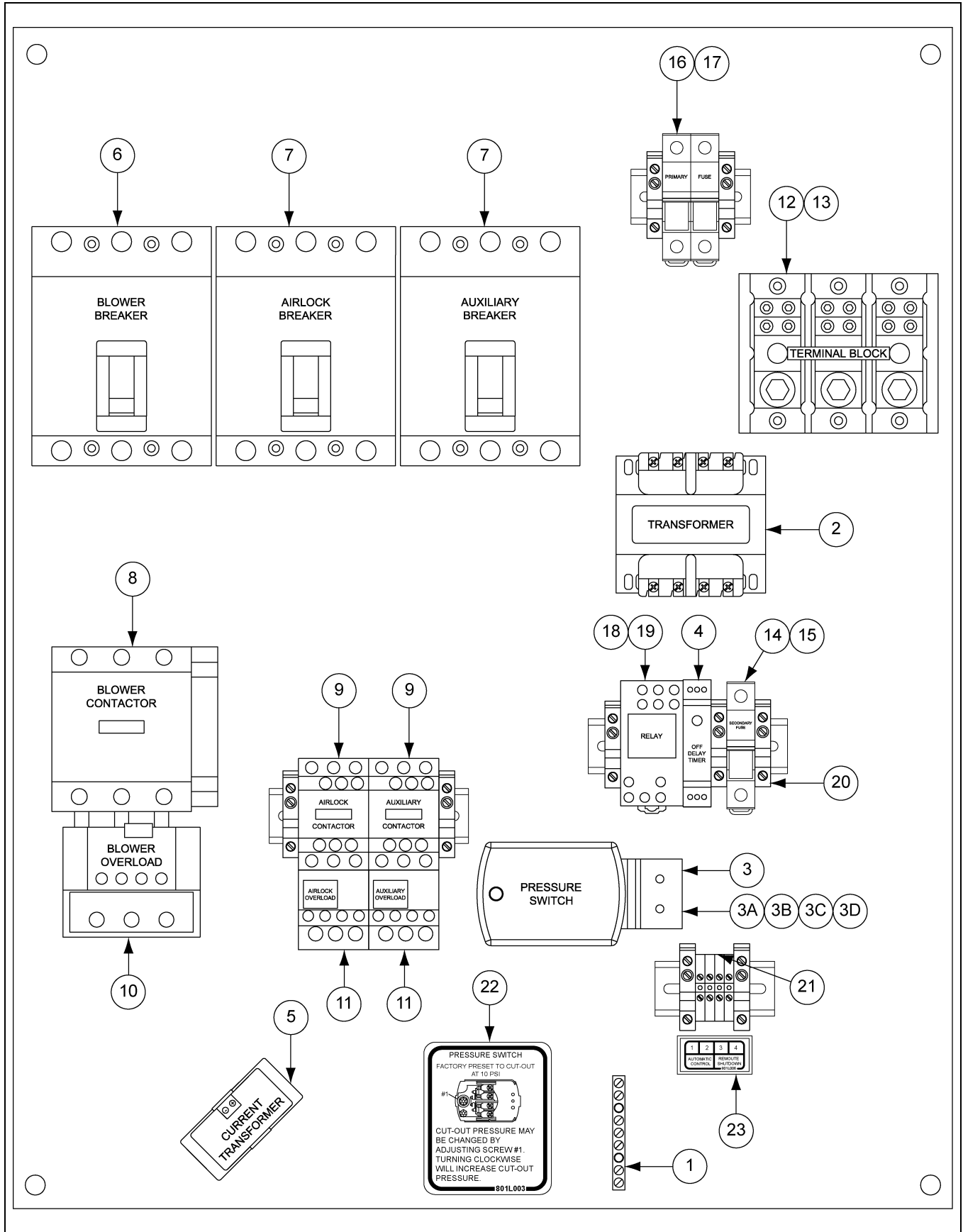

## Standard Control Panel Assembly 10-40 HP 575V - 3 Phase Parts List

Ref #	Part #	Description	Qty				
			AS-0704 10 HP	AS-0705 15 HP	AS-0706 20 HP	AS-0707 30 HP	AS-0708 40 HP
1	AS-0730	Ground Bar Kit	1	1	1	1	1
2	AS-0774	600V - 120/240V Control Transformer	1	1	1	1	1
3	AS-0760	Switch Assembly - High Pressure (Set at 10 PSI)	1	1	1	1	1
3A	801E019	Switch - Pressure (Preset at 10 PSI)	1	1	1	1	1
3B	801E050	Bracket - Pressure Switch	1	1	1	1	1
3C	4FH1465	Tee, Fit - Pipe (PVC) 1/4" x 1/4" x 1/4"	1	1	1	1	1
3D	S-1158	Screw, TCSF #8-32 x 1/2" PHP ZN	2	2	2	2	2
4	AS-0716	Off/Delay Timer 250V 0.7A RE11 + Options	1	1	1	1	1
5	AS-0736	Current Transducer	1	1	1	1	1
6	AS-0776	3P 600V 20A Circuit Breaker	1	-	-	-	-
6	AS-0778	3P 600V 35A Circuit Breaker	-	1	-	-	-
6	AS-0780	3P 600V 45A Circuit Breaker	-	-	1	-	-
6	AS-0782	3P 600V 60A Circuit Breaker	-	-	-	1	-
6	AS-0783	3P 600V 80A Circuit Breaker	-	-	-	-	1
7	AS-0775	3P 600V 15A Circuit Breaker	2	2	2	2	2
8	056-1942-4	12A 110V Contactor	1	-	-	-	-
8	056-1949-9	18A 110V Contactor	-	1	-	-	-
8	AS-0789	25A 110V Contactor	-	-	1	-	-
8	056-1941-6	32A 110V Contactor	-	-	-	1	-
8	AS-0784	50A 110V Contactor	-	-	-	-	1
9	056-1942-4	12A 110V Contactor	2	2	2	2	2
10	AS-0777	9-13A Overload	1	-	-	-	-
10	056-1944-0	12-18A Overload	-	1	-	-	-
10	056-1943-2	17-25A Overload	-	-	1	-	-
10	056-2079-4	25-32A Overload	-	-	-	1	-
10	AS-0752	37-50A Overload	-	-	-	-	1
11	056-1945-7	1.6-2.5A Overload Relay	2	2	2	2	2
12	1EL0911	Power Distribution Block 175A 600V 3 Pole	1	1	1	1	1
13	AS-0742	Clear Distribution Block Cover	1	1	1	1	1
14	AS-0728	2 Amp 600V Special Purpose Fuse	1	1	1	1	1
15	AS-0731	Fuse Holder 600V 30 Amp 1 Pole, CC Fuse	1	1	1	1	1
16	AS-0770	6/10 Amp 600V CC TD Fuse	2	2	2	2	2
17	AS-0732	Fuse Holder 600V 30 Amp 2 Pole, CC Fuse	1	1	1	1	1
18	AS-0722	Relay	1	1	1	1	1
19	AS-0723	Relay - Socket	1	1	1	1	1
20	AS-0758	End Clamp	11	11	11	11	11
21	AS-0759	Terminal Block	4	4	4	4	4
22	801L003	Decal - Pressure Switch	1	1	1	1	1
23	801L006	Decal - Terminal Strip	1	1	1	1	1

## 13. Troubleshooting

Problem	Solution
<p><b>System plugs up.</b></p>	<ol style="list-style-type: none"> <li>1. Check belt tension on air blower and tighten if loose.</li> <li>2. Check air filter and clean out. Locate in a place where there is less dust.</li> <li>3. Check tubing system for any obstructions.</li> <li>4. Reduce feed-in rate.</li> <li>5. Air pressure switch setting may be too low.</li> <li>6. Outlet gate valve too far open.</li> </ol>
<p><b>Excessive grain damage.</b></p>	<ol style="list-style-type: none"> <li>1. May be overfeeding airlock, causing vanes to shear off grain. Reduce feed rate.</li> <li>2. Air velocity may be excessive. Slow air blower by changing pulleys or by opening gate valve.</li> <li>3. Damage can occur if system is running at less than full capacity. Increase feed rate.</li> <li>4. Rubber hose used to change grain direction or used for extended lengths.</li> <li>5. Airlock shear protector installed wrong.</li> </ol>
<p><b>Airlock stops or is noisy.</b></p>	<ol style="list-style-type: none"> <li>1. A foreign object may have become lodged in the airlock vanes.</li> <li>2. Check chain tension.</li> <li>3. Check gearbox drive.</li> <li>4. The rotor vanes may be rubbing on the ends of the airlock. Check clearance at both ends of rotor and center in housing by loosening the set screws in the bearings on both ends of the rotor shaft and moving rotor. Tighten set screws after re-positioning.</li> <li>5. The rotor vanes may have become rusted to the airlock housing. The airlock can be broken loose by using a pipe wrench on the exposed rotor shaft.</li> </ol> <div data-bbox="618 1230 1463 1331" style="border: 1px solid black; padding: 5px; margin: 10px 0;">  <p><b>The worm drive gearbox <u>cannot</u> be driven in reverse and can be damaged. Remove the airlock drive chain before attempting to turn the airlock by hand.</b></p> </div> <ol style="list-style-type: none"> <li>6. "U" cup packings on rotor too tight. (Contact factory)</li> </ol>
<p><b>Unit will not start, "ready light" is not ON.</b></p>	<ol style="list-style-type: none"> <li>1. Check AC power supply.</li> <li>2. Check control box fuses.</li> <li>3. Thermal overload tripped (overload indicator is ON).</li> <li>4. Air pressure limit switch may be misadjusted (less than 5 PSI). If pressure switch is not reset, turn pressure adjustment clockwise until switch resets.</li> <li>5. Be sure "Start" switch is pushed.</li> </ol>
<p><b>Unit will not start, the "ready light" is ON.</b></p>	<ol style="list-style-type: none"> <li>1. Blower, airlock and auxiliary switches must be in either "AUTO" or MANUAL" to operate.</li> <li>2. The automatic control not wired correctly or not working. (Requires a closed contact across TB1 and TB2 to auto start.)</li> </ol>

Problem	Solution
<p><b>Blower motor trips thermal overload.</b></p>	<ol style="list-style-type: none"> <li>1. Check current draw using amp meter. The motor should not be pulling more current than the nameplate specifies. Reduce feed rate if excessive.</li> <li>2. Check overload amp settings.</li> <li>3. Check for loose connections and/or too small gauge wire.</li> <li>4. Wrong voltage (either high or low).</li> <li>5. Too much load due to obstructions, bad bearings or dry gears.</li> </ol>
<p><b>No control voltage.</b></p>	<ol style="list-style-type: none"> <li>1. Control fuse inside the control box is down.</li> <li>2. Check main power for proper voltage.</li> <li>3. Check Transformer Fuses.</li> </ol>

## 14. Couplings

### How to Handle Handling Couplings

1. Couplings are shipped ready-to-install. Do not disassemble. To prevent gasket from slipping out of proper position, always grasp coupling as shown in [Figure 14A](#). This will save time by maintaining proper position of gasket and sleeve in relation to shell and flange.

### Installing Couplings

1. Confirm pipe O.D. size you intend joining. Each compression coupling has been factory inspected for proper O.D. size before shipment.
2. Be sure outside surface of pipe is dry and free of dirt, grease or external burrs. (Burrs and jagged pipe ends can cut gasket; dirt and grease can cause coupling slippage.)
3. Grasp coupling as shown in [Figure 14A](#) to keep gasket and sleeve (and gasket protector when used) in separate quadrants, as shown in [Figure 14A](#). Be sure gasket teeth mesh and do not overlap.
4. Slide coupling over one pipe past end, then butt pipe ends. (A small gap 1/16 maximum at butt joint will not reduce coupling performance.) Slide coupling back until coupling and gasket protector are centered over joint. Use care when sliding coupling into place. Avoid wrinkling of gasket or gasket protector.
5. The gasket protector provides a bleed path for static electricity.
6. Partially tighten bolts evenly as follows:

1/2" Bolt size - 45 ft. lbs. torque

5/8" Bolt size - 65 ft. lbs. torque

3/4" Bolt size - 95 ft. lbs. torque

(Where SAE grade 5 5/8" bolts are specified tighten to 95 ft. lbs. For couplings with aluminum shell and inner sleeve do not exceed 40 ft. lbs.)

7. When properly and evenly tightened to the recommended torque the coupling installation is complete. The top edges of the flanges will touch and flanges appear as a vee when viewed from the end, as shown in [Figure 14A](#). **DO NOT** attempt tightening bolts to flatten flange faces together, as this exceeds recommended limits.

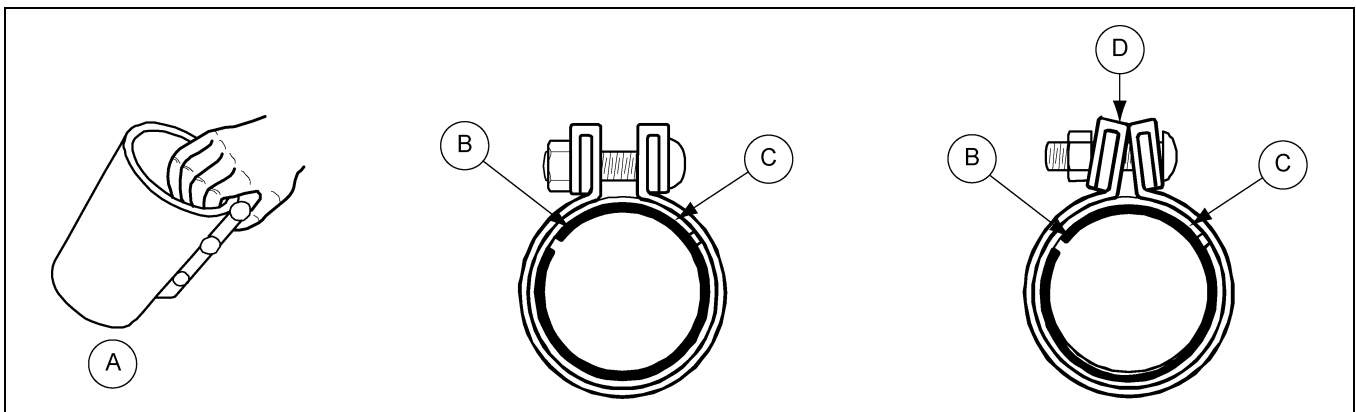

Figure 14A

Ref #	Description	Ref #	Description
A	Grasp as shown	C	Sleeve Location
B	Gasket Location	D	Top of Flange



## Limited Warranty — N.A. Grain Products

The GSI Group, LLC. ("GSI") warrants products which it manufactures, to be free of defects in materials and workmanship under normal usage and conditions for a period of 12 months from the date of shipment (or, if shipped by vessel, 14 months from the date of arrival at the port of discharge). If, in GSI's sole judgment, a product is found to have a defect in materials and/or workmanship, GSI will, at its own option and expense, repair or replace the product or refund the purchase price. This Limited Warranty is subject to extension and other terms as set forth below.

**Warranty Enhancements:** The warranty period for the following products is enhanced as shown below and is in lieu of (and not in addition to) the above stated warranty period. (Warranty Period is from date of shipment.)

	Product	Warranty Period
<b>Storage</b>	Grain Bin Structural Design • Sidewall, roof, doors, platforms and walkarounds • Flooring (when installed using GSI specified floor support system for that floor) • Hopper tanks (BFT, GHT, NCHT, and FCHT)	5 Years
<b>Conditioning</b>	Dryer Structural Design – (Tower, Portable and TopDry) • Includes (frame, portable dryer screens, ladders, access doors and platforms)	5 Years
	All other Dryer parts including: • Electrical (controls, sensors, switches and internal wiring)	2 Years
	All Non-PTO Driven Centrifugal and Axial Fans	3 Years
	Bullseye Controllers	2 Years
<b>Material Handling</b>	Bucket Elevators Structural Design	5 Years
	Towers Structural Design	5 Years
	Catwalks Structural Design	5 Years
	Accessories (stairs, ladders and platforms) Structural Design	5 Years

### Conditions and Limitations:

THERE ARE NO WARRANTIES THAT EXTEND BEYOND THE LIMITED WARRANTY DESCRIPTION SET FORTH HEREIN; SPECIFICALLY, GSI DISCLAIMS ANY AND ALL OTHER WARRANTIES OF ANY KIND, EXPRESS OR IMPLIED, INCLUDING, WITHOUT LIMITATION, WARRANTIES OF MERCHANTABILITY OR FITNESS FOR A PARTICULAR PURPOSE OR USE IN CONNECTION WITH: (I) ANY PRODUCT MANUFACTURED OR SOLD BY GSI, OR (II) ANY ADVICE, INSTRUCTION, RECOMMENDATION OR SUGGESTION PROVIDED BY AN AGENT, REPRESENTATIVE OR EMPLOYEE OF GSI REGARDING OR RELATED TO THE CONFIGURATION, INSTALLATION, LAYOUT, SUITABILITY FOR A PARTICULAR PURPOSE, OR DESIGN OF SUCH PRODUCTS.

The sole and exclusive remedy for any claimant is set forth in this Limited Warranty and shall not exceed the amount paid for the product purchased. This Warranty only covers the value of the warranted parts and equipment, and does not cover labor charges for removing or installing defective parts, shipping charges with respect to such parts, any applicable sales or other taxes, or any other charges or expenses not specified in this Warranty. GSI shall not be liable for any other direct, indirect, incidental or consequential damages, including, without limitation, loss of anticipated profits or benefits. Expenses incurred by or on behalf of a claimant without prior written authorization from the GSI warranty department shall not be reimbursed. This warranty is not transferable and applies only to the original end-user. GSI shall have no obligation or responsibility for any representations or warranties made by or on behalf of any dealer, agent or distributor. Prior to installation, the end-user bears all responsibility to comply with federal, state and local codes which apply to the location and installation of the products.

This Limited Warranty extends solely to products sold by GSI and does not cover any parts, components or materials used in conjunction with the product, that are not sold by GSI. GSI assumes no responsibility for claims resulting from construction defects, unauthorized modifications, corrosion or other cosmetic issues caused by storage, application or environmental conditions. Modifications to products not specifically delineated in the manual accompanying the product at initial sale will void all warranties. This Limited Warranty shall not extend to products or parts which have been damaged by negligent use, misuse, alteration, accident or which have been improperly/inadequately maintained.

#### Notice Procedure:

In order to make a valid warranty claim a written notice of the claim must be submitted, using the RMA form, within 60 days of discovery of a warrantable nonconformance. The RMA form is found on the OneGSI portal.

#### Service Parts:

GSI warrants, subject to all other conditions described in this Warranty, Service Parts which it manufactures for a period of 12 months from the date of purchase unless specified in Enhancements above.

This equipment shall be installed in accordance with the current installation codes and applicable regulations, which should be carefully followed in all cases. Authorities having jurisdiction should be consulted before installations are made.



1004 E. Illinois St.  
Assumption, IL 62510-0020  
Phone: 1-217-226-4421  
Fax: 1-217-226-4420  
[www.gsiag.com](http://www.gsiag.com)



GSI is a worldwide brand of AGCO Corporation.