

6" Air System MFT Airlocks

6" - 2100 Bu/Hr

Owner's Manual

PNEG-1949

Version: 2.0

Date: 04-13-16



PNEG-1949

All information, illustrations, photos, and specifications in this manual are based on the latest information available at the time of publication. The right is reserved to make changes at any time without notice.

Contents

Chapter 1 Safety	4
Safety Guidelines	4
Cautionary Symbols Definitions	5
Safety Cautions	6
Safety Sign-Off Sheet	8
Chapter 2 Decals	9
Decal Placement	9
Chapter 3 Maintenance	12
Chapter 4 Air System	13
Air System Capacities	13
Capacity Chart	13
Chapter 5 Installation	14
Air System Installation Instructions	14
Air System Capacities	15
Air System Tubing Dimensions	16
Chapter 6 Dimensions	18
Elbow Angle Measurements	18
Chapter 7 Assembly	19
Air System Set-Up Procedure	19
6" Air System 2100 Motor Mounting Locations	23
Air System Control Box Definitions	24
Chapter 8 Overload Chart	27
6" Overload Set Chart	27
Chapter 9 Schematic Diagram	28
Schematic - 230V/460V/575V-3 PH	28
Chapter 10 Operation and Management	29
Control Box Operational Procedures	29
Air System Operation Guidelines	30
Chapter 11 Hook-Up Diagrams	32
Chapter 12 Parts List	35
Blower Outlet Parts	36
6" (2100) with 3500 RPM Motors Blower Parts	38
Blower Filter Parts	41
6" Airlock Parts	42
Airlock Inlet Transition Assembly	44
Inner Door Assembly	45
Control Panel Parts 230V - 3 PH	46
Control Panel Parts 460V - 3 PH	48
Control Panel Parts 575V - 3 PH	50
Chapter 13 Troubleshooting	52
Chapter 14 Coupling	53
How to Handle Handling Couplings	53
Chapter 15 Warranty	55

Safety Guidelines

Safety guidelines are general-to-specific safety rules that must be followed at all times. This manual is written to help you understand safe operating procedures and problems that can be encountered by the operator and other personnel when using this equipment. Save these safety guidelines for future reference.

As owner or operator, you are responsible for understanding the requirements, hazards, and precautions that exist and to inform others as required. Unqualified persons must stay out of the work area at all times.

Alterations must not be made to the equipment. Alterations can produce dangerous situations resulting in **SERIOUS INJURY** or **DEATH**.

This equipment must be installed in accordance with the current installation codes and applicable regulations, which must be carefully followed in all cases. Authorities having jurisdiction must be consulted before installations are made.

When necessary, you must consider the installation location relative to electrical, fuel and water utilities.

Personnel operating or working around equipment must read this manual. This manual must be delivered with equipment to its owner. Failure to read this manual and its safety instructions is a misuse of the equipment.

ST-0001-3

Cautionary Symbols Definitions

Cautionary symbols appear in this manual and on product decals. The symbols alert the user of potential safety hazards, prohibited activities and mandatory actions. To help you recognize this information, we use the symbols that are defined below.



This symbol indicates an imminently hazardous situation which, if not avoided, **will result in serious injury or death.**



This symbol indicates a potentially hazardous situation which, if not avoided, **can result in serious injury or death.**



This symbol indicates a potentially hazardous situation which, if not avoided, **can result in minor or moderate injury.**



This symbol is used to address practices not related to personal injury.



This symbol indicates a general hazard.



This symbol indicates a prohibited activity.

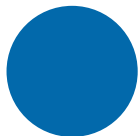

This symbol indicates a mandatory action.

ST-0005-2

Safety Cautions

Use Personal Protective Equipment

- Use appropriate personal protective equipment:

Eye Protection



Respiratory Protection



Foot Protection



Hearing Protection



Head Protection



Fall Protection



Hand Protection



- Wear clothing appropriate to the job.
- Remove all jewelry.
- Tie long hair up and back.

ST-0004-1

Follow Safety Instructions

- Carefully read all safety messages in this manual and safety signs on your machine. Keep signs in good condition. Replace missing or damaged safety signs. Be sure new equipment components and repair parts include the current safety signs. Replacement safety signs are available from the manufacturer.
- Learn how to operate the machine and how to use controls properly. Do not let anyone operate without instruction.
- If you do not understand any part of this manual or need assistance, contact your dealer.



ST-0002-1

Sharp Edge Hazard

- This product has sharp edges, which can cause serious injury.
- To avoid injury, handle sharp edges with caution and always use proper protective clothing and equipment.



ST-0036-2

Stay Clear of Moving Parts and Air Valves

- Entanglement in rotating sprocket or moving chain will cause serious injury or death. Wear close fitting clothing.
- Keep all shields and covers in place at all times.
- Lock-out power source before making adjustments, cleaning, or maintaining equipment.
- Stay clear of air blast from valve. Always wear safety glasses to protect your eyes from flying debris.

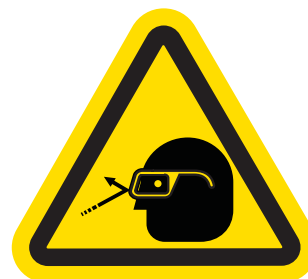

ST-0048-1

Install and Operate Electrical Equipment Properly

- Electrical controls must be installed by a qualified electrician and must meet the standards set by the National Electric Code, Canadian Electrical Code, and all local and state codes.
- Lock-out power source before making adjustments, cleaning, or maintaining equipment.

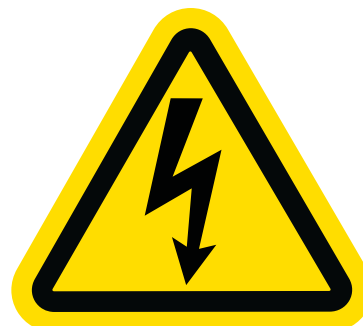

ST-0027-2

Maintain Equipment and Work Area

- Understand service procedures before doing work. Keep area clean and dry.
- Never service equipment while it is operating. Keep hands, feet, and clothing away from moving parts
- Keep your equipment in proper working condition. Replace worn or broken parts immediately.



ST-0003-1

1. Safety

Safety Sign-Off Sheet

Below is a sign-off sheet that can be used to verify that all personnel have read and understood the safety instructions. This sign-off sheet is provided for your convenience and personal record keeping.

<i>Date</i>	<i>Employee Name</i>	<i>Supervisor Name</i>

ST-0007

Decal Placement

Airlock Base

For decal replacements contact GSI at:

GSI Decals

1004 E. Illinois St.
Assumption, IL. 62510
Phone: 1-217-226-4421

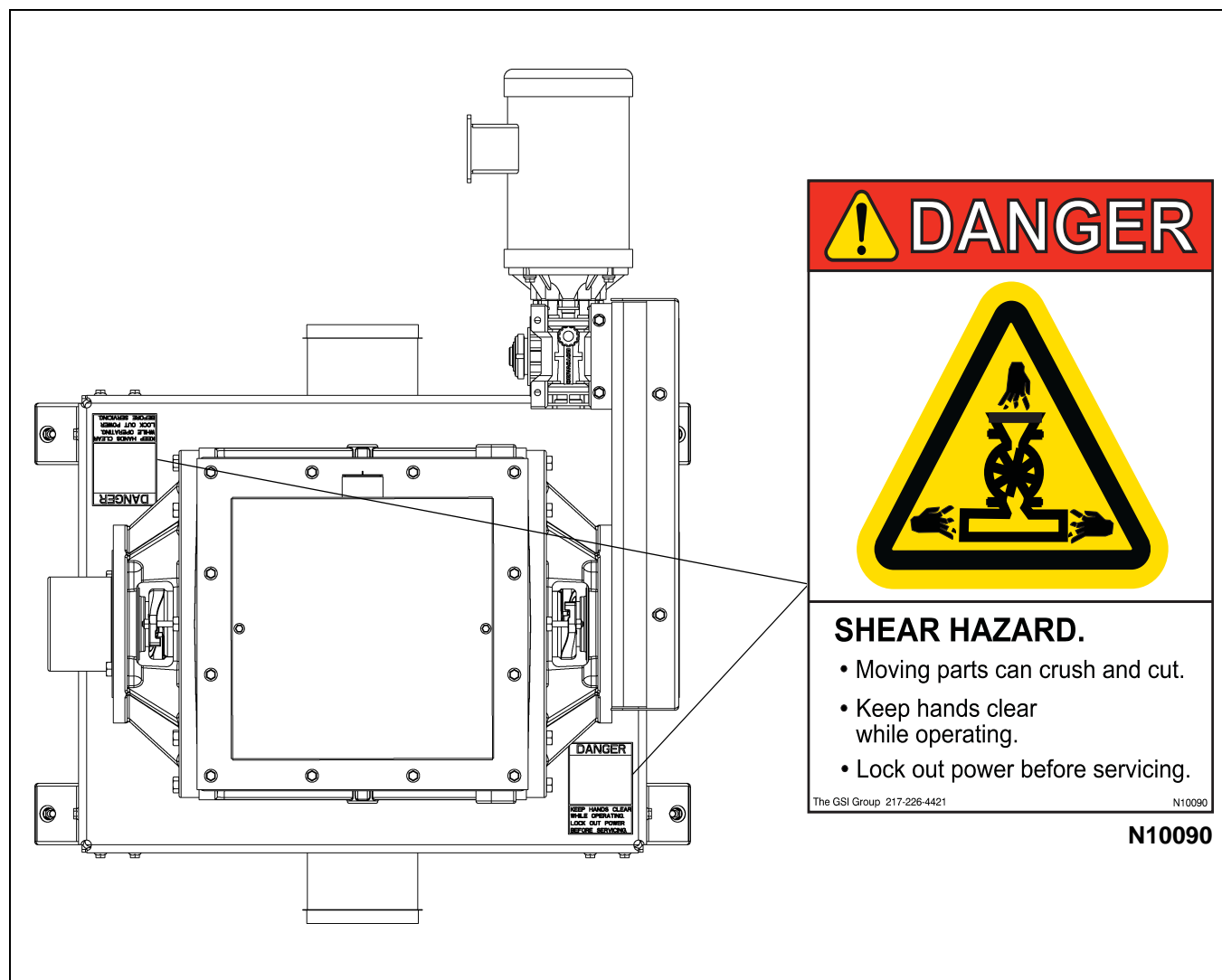

Figure 2A Airlock Base

2. Decals

Blower Base and Guard

For decal replacements contact GSI at:

GSI Decals

1004 E. Illinois St.
Assumption, IL. 62510
Phone: 1-217-226-4421

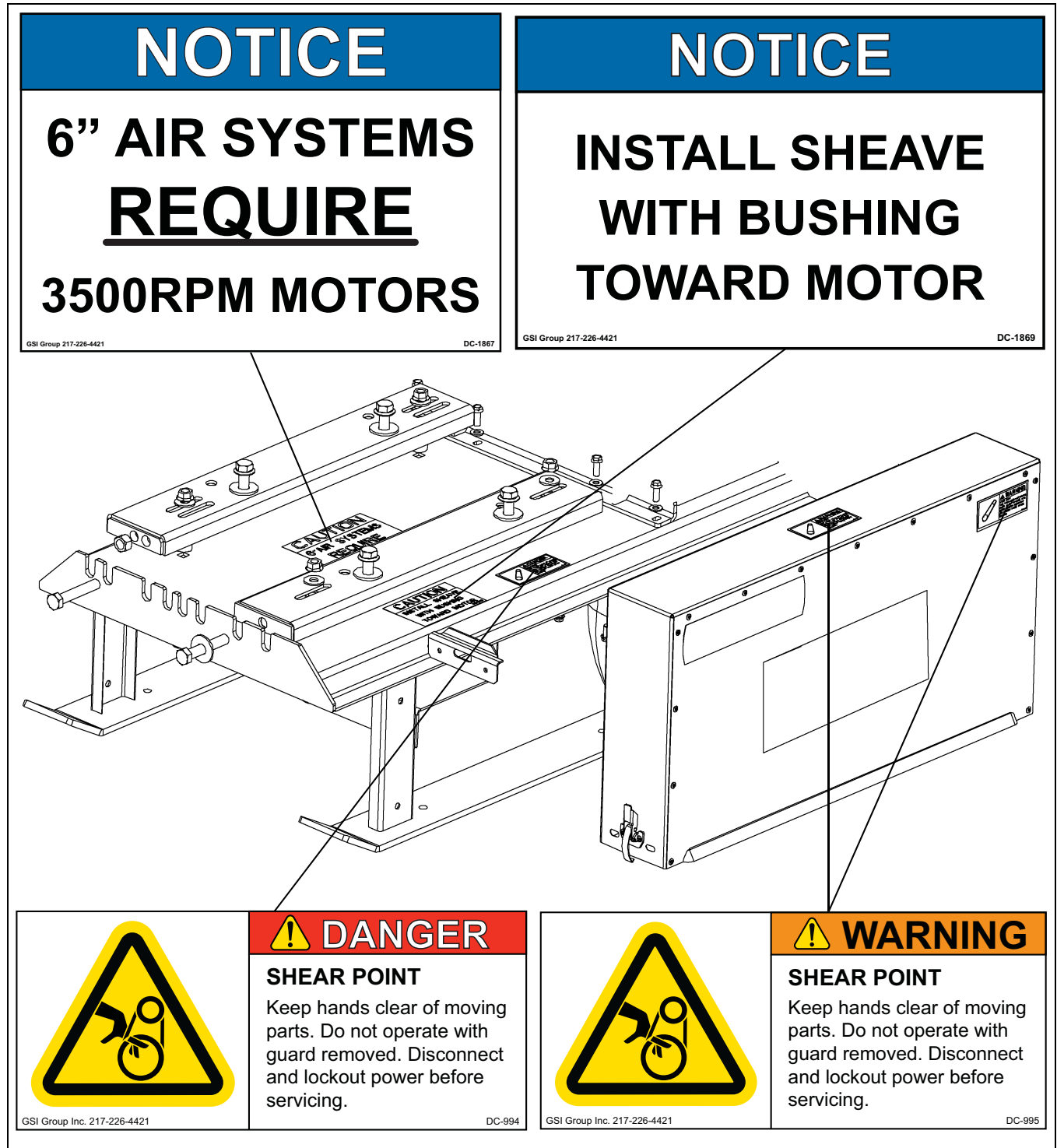

Figure 2B Blower Base and Guard

Airlock Guard

For decal replacements contact GSI at:

GSI Decals

1004 E. Illinois St.
 Assumption, IL. 62510
 Phone: 1-217-226-4421

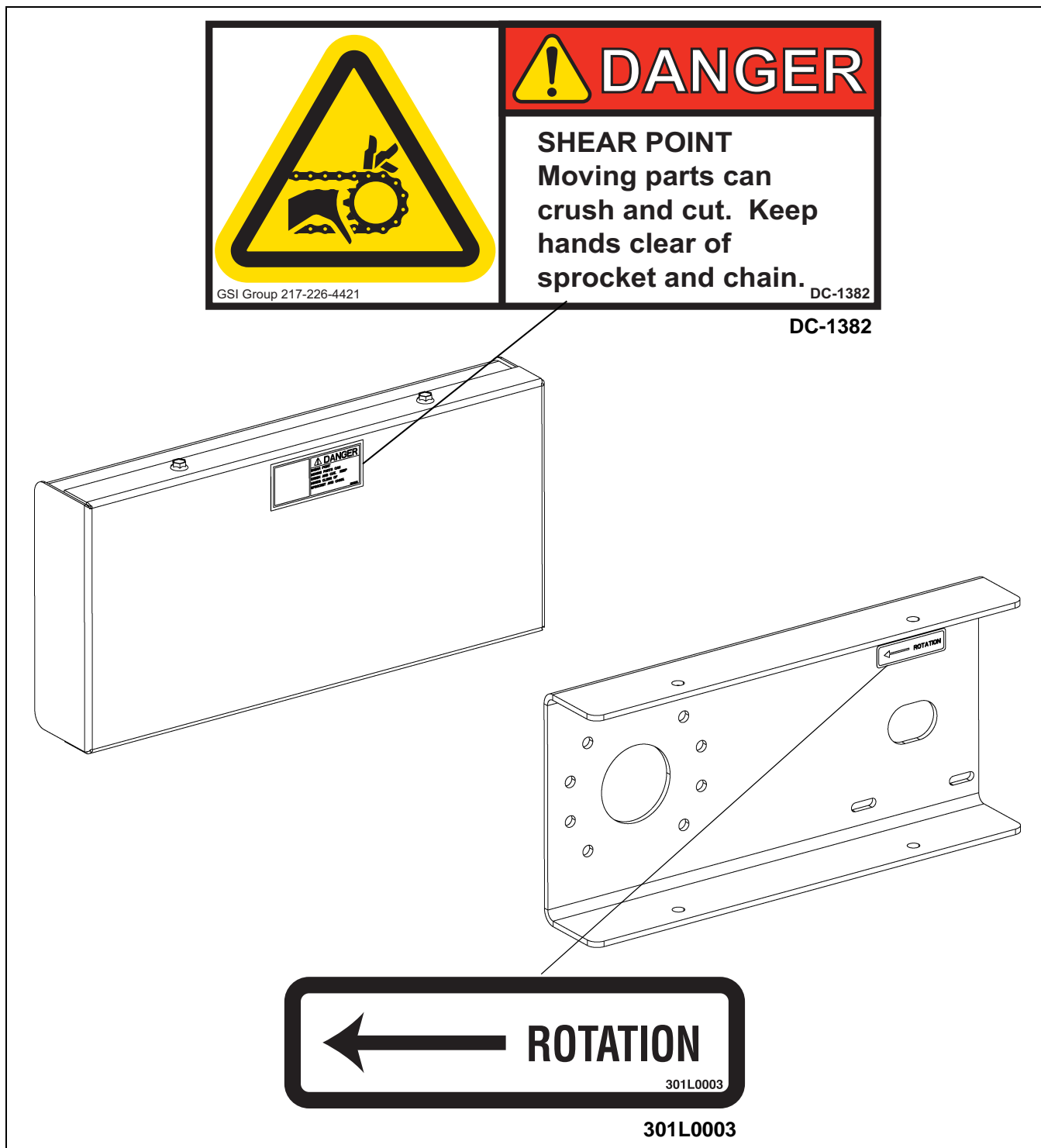

Figure 2C Airlock Guard

3. Maintenance

Maintenance Schedule

Initial Start-Up	
1. Dura Flow	1. Oil level with middle of sight glass (AS-0886 synthetic oil).
2. Airlock Gearbox	2. Gearbox is sealed.
3. Air Filter	3. Installed properly.
4. Chain	4. Tensioned and aligned.
5. Tubing System	5. All couplers tight. All tubing connections have good fit. Tubing laid out straight. Elbows fitting properly.
After First 10 Hours and Daily	
1. Air Filter	1. Check for excessive dust build-up.
2. Tubing	2. Check all connections for leaks and signs of separating.
Weekly	
1. Chain	1. Oil
2. Blowers and Gearbox	2. Check oil levels
1500 Hours (Synthetic Oil)	
1. Dura Flow	1. Drain oil and replace with 1.5 Qts. of AS-0886 synthetic oil. (Fill to middle of sight glass.)
Extended Shut Down	
Disconnect Main Power Unit.	
1. Blower	1. Remove inlet assembly and spray oil on lobes while rotating by hand, to prevent rust. Keep hands and objects out of blower. Re-install inlet assembly.
2. Airlock	2. Coat interior with oil, while rotating by hand, to prevent rust. Re-install weather cover.
3. Chain	3. Oil chain to prevent rust.

Air System Capacities (Dry Shelled Corn)

Effective Length (Feet)	2100 Bu/Hr 6" System (Dura Flow)			
	40 HP Motor	50 HP Motor	60 HP Motor	75 HP Motor
50	1900	2200	2350	2500
100	1875	2175	2325	2475
150	1850	2150	2300	2450
200	1800	2100	2100	2400
250	1700	2000	2150	2300
300	1550	1850	2000	2150
350	1375	1675	1825	1975
400	1150	1450	1600	1750
450	875	1175	1325	1475
500	500	800	950	1100

Effective tube length is determined by adding the horizontal length, twice the vertical height and 10' for every elbow of 45° or greater. Add 5' for each elbow less than 45°. Use the horizontal run and add the vertical rise of inclined systems to calculate the effective length.

Capacity Chart

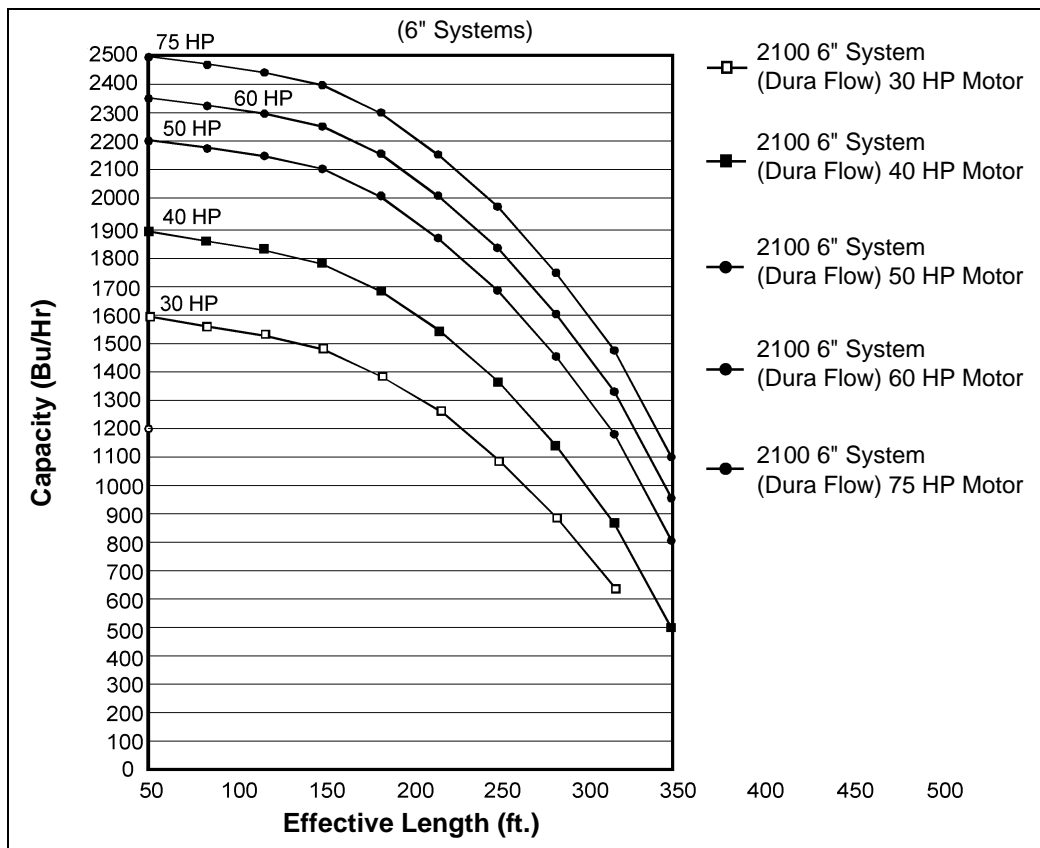

Figure 4A

Air System Installation Instructions

1. Determine the most convenient location for the airlock and blower. Take into consideration the direction of the prevailing winds. It is important to locate the blower in as clean an environment as possible. This greatly reduces the maintenance requirements on the air filter system. When the distance between the airlock and blower is over 10', it is best to use galvanized pipe with short flex hose on the ends to couple the units together to keep airflow restrictions to a minimum.
2. The noise level of the blower unit can be reduced by placing the unit behind a wall, barrier or in a small building. If this is done, make sure that the building has adequate ventilation for both air intake and cooling of the blower and motor.
3. The grain discharge chute on the airlock is assembled at the factory so that grain movement is at 90° to the length of the skid. This orientation can be changed by removing the mounting hardware at the base of the airlock and rotating the discharge chute to the preferred direction. Be sure to use silicone to seal the discharge to the skid. Note that the airlock itself is sealed to the skid surface and does not need to be moved to redirect the discharge chute.

NOTE: *A minimum of 10' is needed between the airlock discharge and the first elbow in the system.*

4. Determine the best routing of the galvanized steel pipe from the airlock to the storage areas. Use galvanized elbows for changing the grain direction. This will give better performance and longer life than flex hose.
5. Bolt the tube mounting brackets to the desired location using at least two (2) mounting brackets on the vertical wall and two (2) on the roof of the grain bin. The mounting brackets can be formed to match existing hole patterns in the bin.
6. Determine the number and degree of arc required in the elbows. The 90° and 60° elbows are standard - different lengths of arc can be cut from these standard elbows. ([See Page 18.](#))

NOTE: *A minimum of 8' between elbows is required for proper operation.*

7. Cut the steel tubing to the required length and fasten it together with compression couplings. The ends must be cut square to fit properly. Make sure that the stainless steel gasket protecting sleeve is placed over the joint before tightening the coupler. Tighten the bolts on the coupler evenly or until the coupler flanges butt together. ([See Page 53.](#))
8. The steel tubing can be laid underground, on top of the ground or placed on blocks. If placed on blocks, the tubing must be supported every 15'. If placed underground, the tube should enter and exit the ground at a 45° angle and be coated with a protective tar to prevent corrosion.
9. Measure the distance between the airlock and blower. Use flex hose or a combination of flex hose and galvanized tubing to connect the units together. Note that the grain discharge chute on the airlock is tapered and that grain can discharge in either direction.
10. Install all tubing required to transfer grain to the storage areas.
11. To attach the deadhead deflector to the tubing, simply slide the deadhead deflector onto the tubing and tighten the clamp provided. Flexible galvanized tubing can be attached to the deadhead down spout if needed. If a cyclone is used, an elbow and mounting brackets are needed.
12. Select a location to mount the electrical control box that is accessible and easily reached should shut down of unit be necessary. It should be close enough to the blower to run the 30' of rubber pressure hose between the blower and the control box. Otherwise, a longer length of hose must be ordered.
13. Before wiring or operating the Air System unit, read the control box description [on Pages 24 to 26](#) understand the operation of the Air System control box. If the control box is to be wired to remote equipment, review the wiring diagrams for proper hook-up.

Air System Capacities

(Dry Shelled Corn)

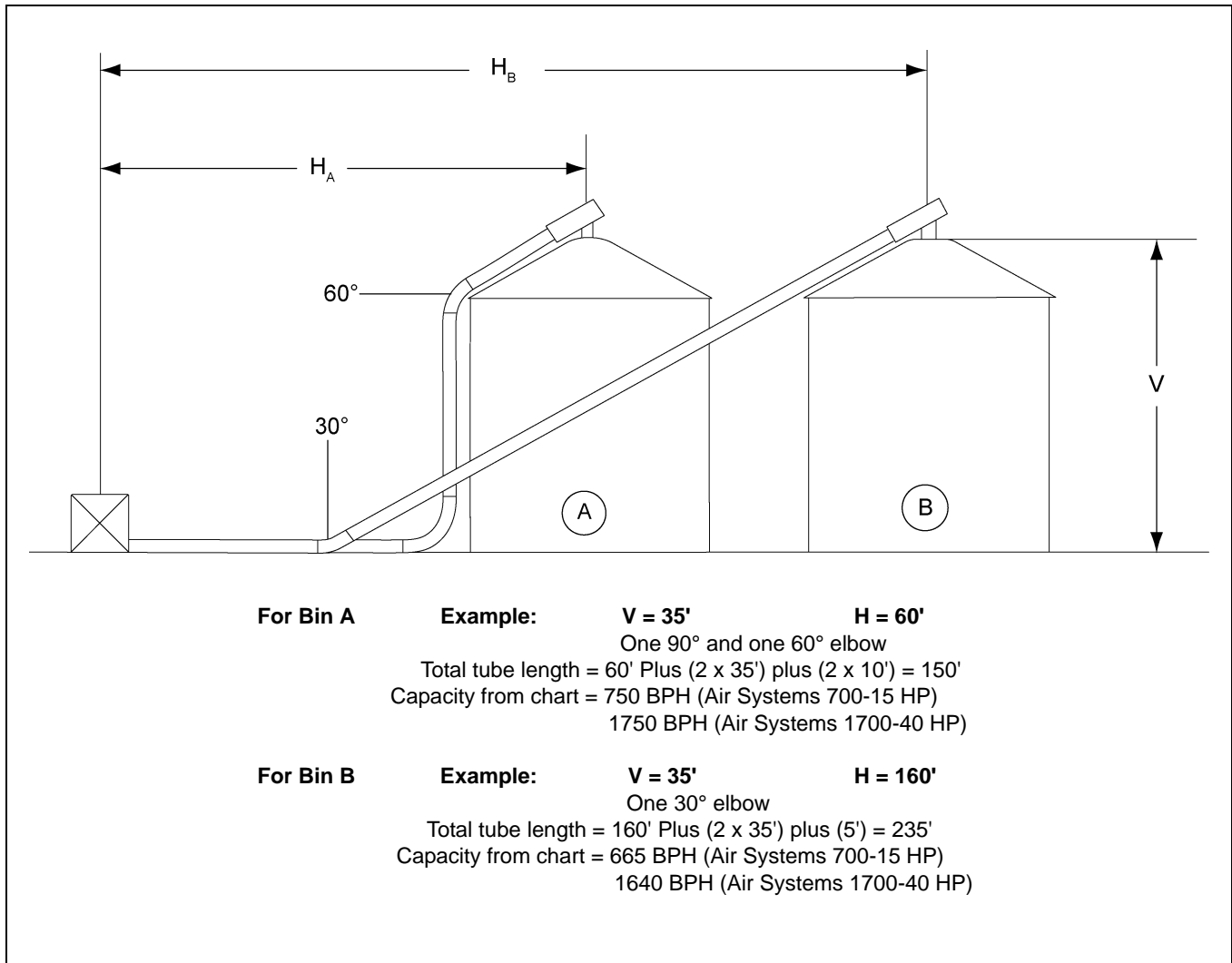

Figure 5A

Air System Tubing Dimensions

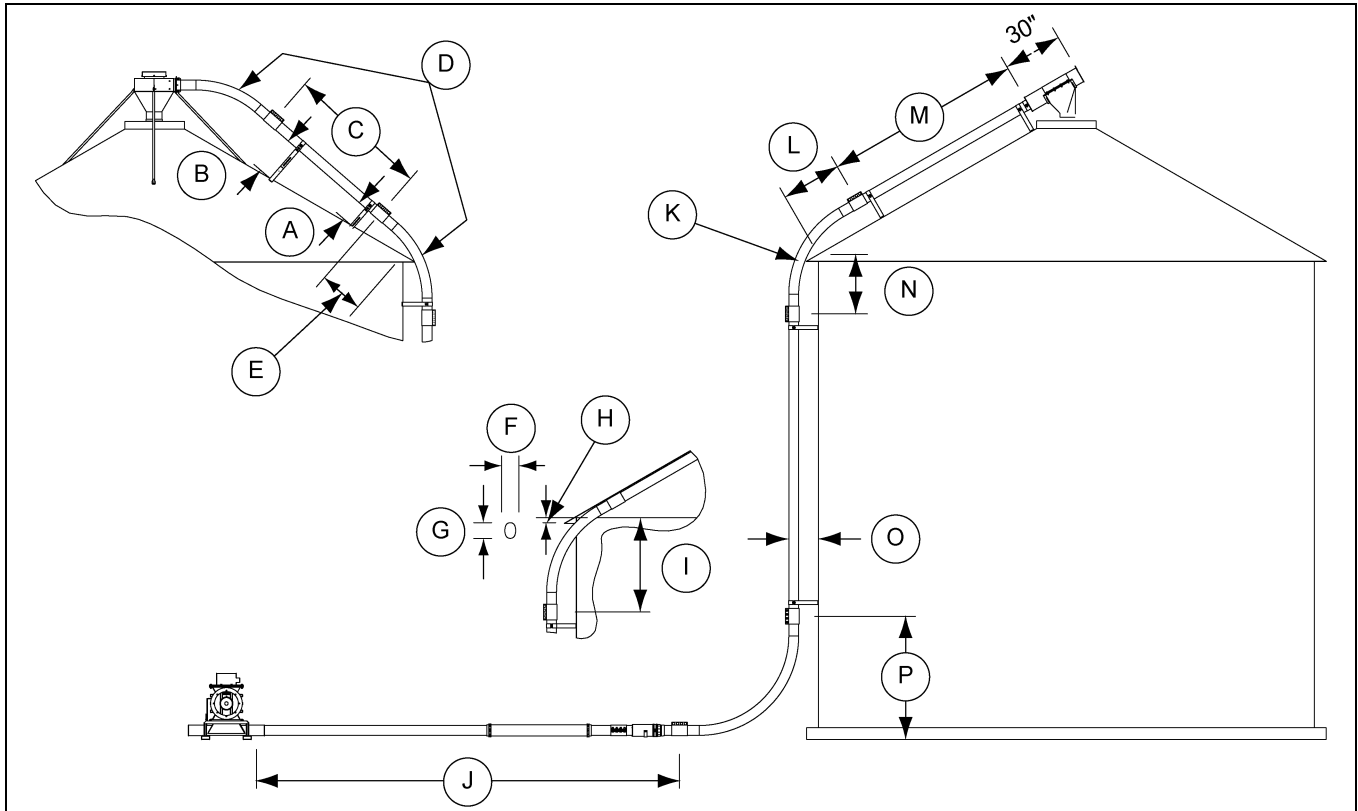

Figure 5B

Ref #	Description
A	12" Minimum
B	21" Maximum
C	Cut to Fit
D	Cut one full 90° elbow to make both pieces.
E	Not the same as "B" dimension.
F	Width equals tube diameter.
G	6" for 4", 7-1/2" for 5", 9" for 6"
H	"D" Dimension (See Page 17.)
I	"C" Dimension (See Page 17.)
J	10' Minimum distance to first elbow.
K	Use a standard 60° elbow with straight tangents on both ends for 30° roofs.
L	"B" Dimension (See Page 17.)
M	"E" Dimension (See Page 17.)
N	"A" Dimension (See Page 17.)
O	10" Standard Bracket
P	58" for 4", 60-1/2" for 5", 61" for 6"

Cut a standard 90° elbow to fit roof angles other than 30°. Position the cut end on the roof.

Air System Tubing Dimensions (Continued)

System Size	Roof Angle	Reference Dimension												
		A	B	C	D	E *								
						18' Dia.	21' Dia.	24' Dia.	27' Dia.	30' Dia.	33' Dia.	36' Dia.	42' Dia.	48' Dia.
4"	25	31"	23"	47-1/2"	5-3/4"	7' 1"	8' 9"	10' 5"	12' 1"	13' 9"	15' 5"	17' 1"	20' 5"	23' 9"
	30	29"	29"	46"	3-1/2"	7' 1"	8' 9"	10' 5"	12' 1"	13' 9"	15' 5"	17' 1"	20' 5"	23' 9"
	35	27"	19"	45"	2-1/2"	8' 6"	10' 2"	11' 10"	13' 6"	15' 2"	16' 10"	18' 6"	21' 10"	25' 2"
5"	25	32-1/2"	22-1/2"	50"	4-1/2"	7'	8' 9"	10' 6"	12' 3"	14'	15' 9"	17' 6"	21'	24' 6"
	30	30-1/2"	30-1/2"	49"	3-1/4"	6' 10"	8' 7"	10' 4"	12' 1"	13' 10"	15' 7"	17' 4"	20' 10"	24' 4"
	35	28-1/2"	18-1/2"	48"	2-1/4"	8' 6"	10' 3"	12'	13' 9"	15' 6"	17' 3"	19'	22' 6"	26'
6"	25	32-1/4"	22-1/4"	51"	4-1/2"	7' 3"	9' 1"	10' 11"	12' 9"	14' 7"	16' 5"	18' 3"	21' 11"	25' 7"
	30	30-1/4"	30"	50"	3"	7' 1"	8' 11"	10' 9"	12' 7"	14' 5"	16' 3"	18' 1"	21' 9"	25' 5"
	35	28-1/4"	18"	49"	2"	8' 8"	10' 6"	12' 4"	14' 2"	16'	17' 10"	19' 9"	22' 4"	27'

* Add 10" to "E" dimension if roof elbow has been cut from a 90° elbow.

Elbow Angle Measurements

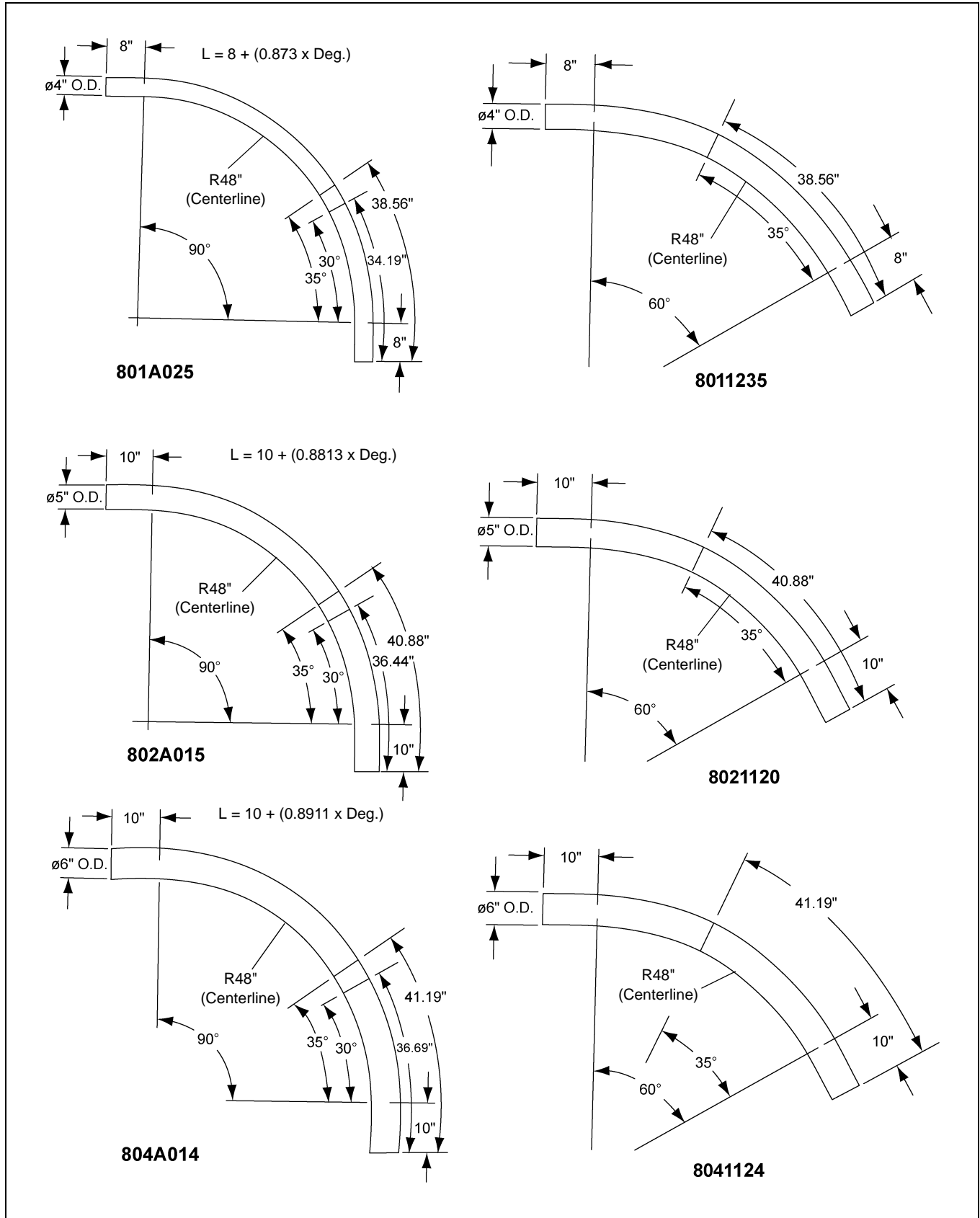

Figure 6A

Air System Set-Up Procedure

1. The air filter extension tube and housing are connected to the blower inlet by a compression coupler. (See [Figure 7A](#), [Figure 7B](#) and [Figure 7C](#).) For extended filter life, if the pneumatic system is being operated in extremely dirty conditions, a longer extension tube can be used between the blower inlet and the air filter. BE SURE the air filter is positioned so that routine inspection and service can be performed.
2. Place the air filter element with pre-filter on the base and cover with the filter canister using the 3/8" wing nut and washer. The wing nut does not need to be more than finger tight. (See [Figure 7B](#) and [Figure 7C](#).)

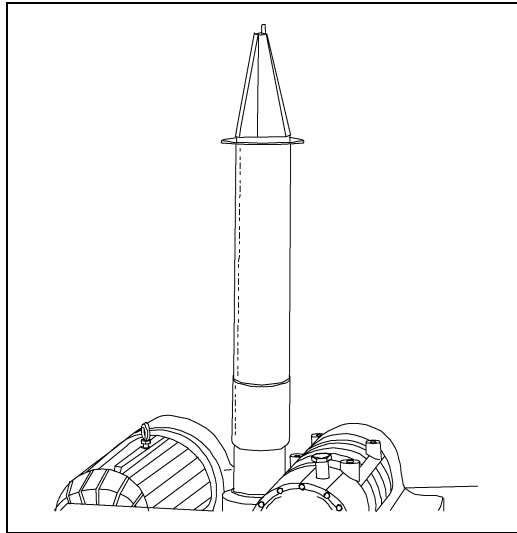

Figure 7A

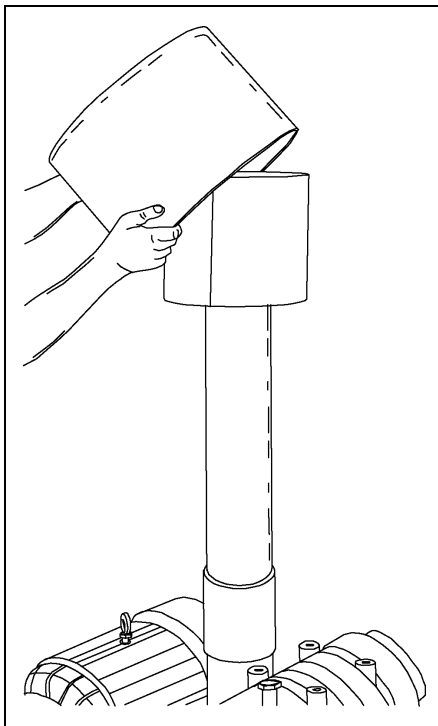

Figure 7B

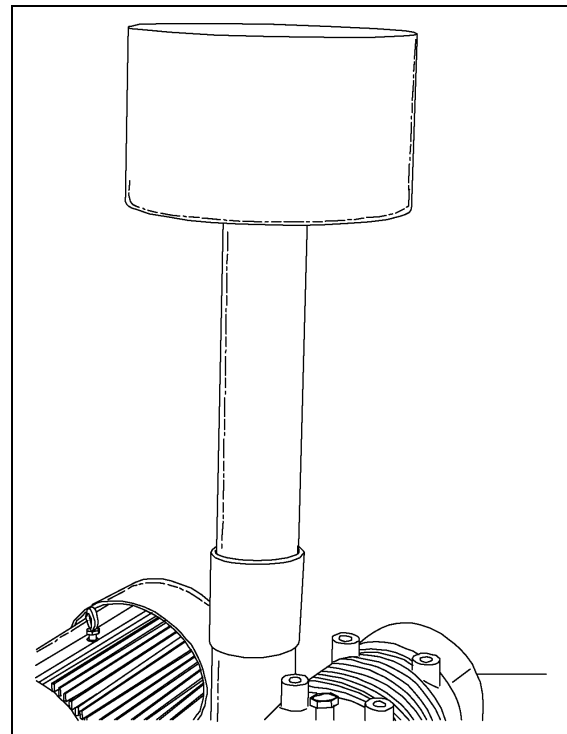

Figure 7C

7. Assembly

3. Check the motor nameplate for the correct motor frame size. Then refer to [Figure 7L on Page 23](#) to determine proper mounting holes and spacing of the motor mount channel. The spacing of the motor mount channels is changed by moving the channel to the proper notch cut into the main base of the blower platform. [See Figure 7D](#) and refer to [Figure 7L on Page 23](#). Finish by bolting the motor securely to the channels. Leave the four (4) 1/2" carriage bolts loose, holding the channels to the main frame.
4. Place the pulley and taper lock bushing onto the motor and align it with the blower pulley. ([See Figure 7E.](#)) Install the bushing on the inside of the sheave toward the motor.

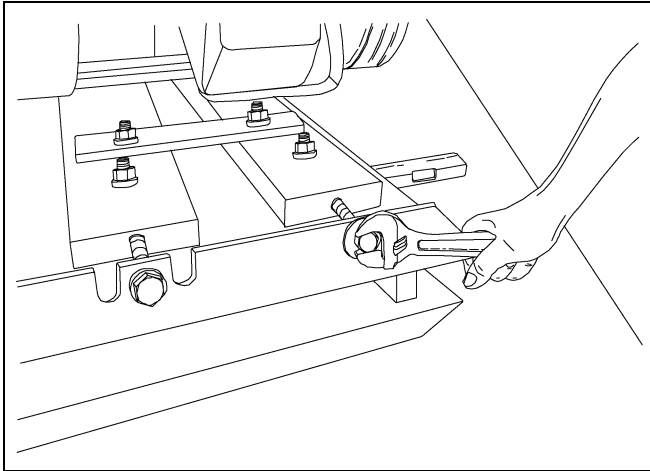

Figure 7D

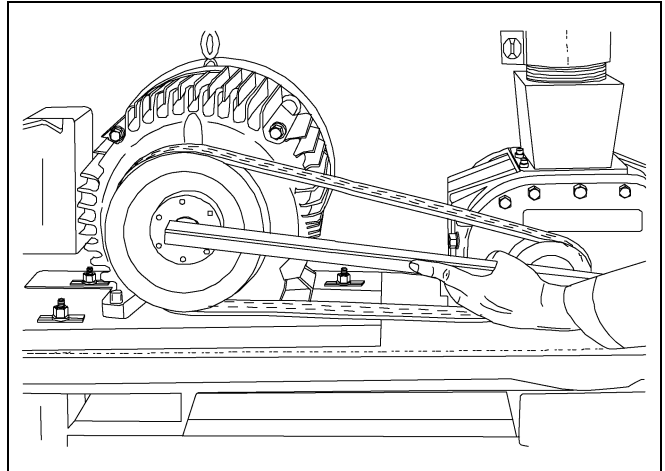

Figure 7E

5. Place the matching set of V-belts on the pulleys. Tighten the belts by evenly turning the cap screws clockwise. Belts should have 3/8" deflection at 10 pounds pressure per belt. ([See Figure 7D.](#))
6. Keeping the motor in proper alignment is necessary and can be accomplished by using an open end wrench to turn the nut on the opposite motor mount channel, moving the channel either direction until proper alignment is achieved. Squaring up the motor can change the tension of the belts. Re-check alignment and tension. Finish [Step 4](#) by tightening the four (4) 1/2" bolts left loose earlier. ([See Figure 7F and Figure 7G.](#))

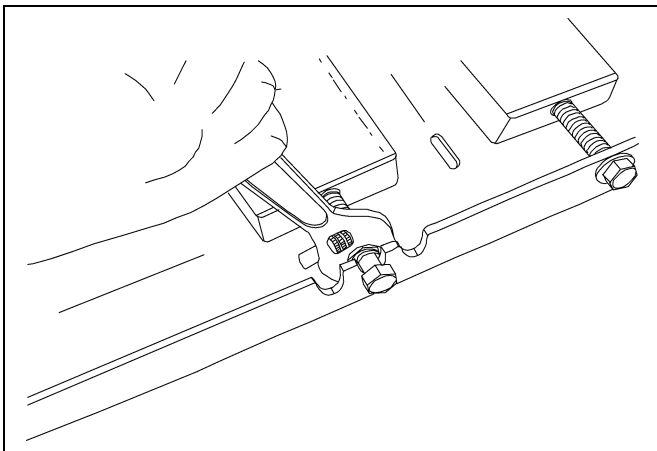

Figure 7F

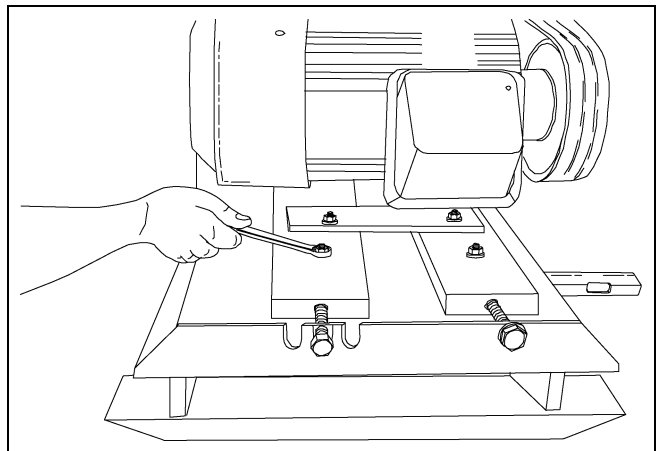

Figure 7G

7. Check the oil level of the blower. The oil level should be at the center of the sight glass. Add part #AS-0886, if required, through the breather plug on top of the blower case. (See Figure 7H.) See the maintenance schedule on Page 12 for the frequency of oil changes.

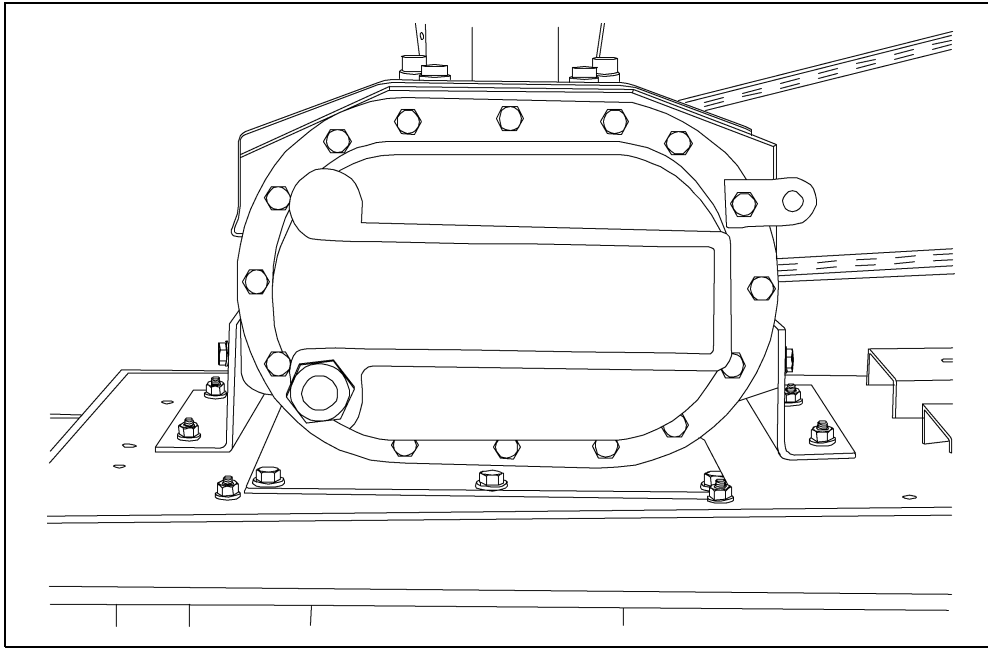

Figure 7H

8. Using four (4) 5/16" x 3/4" flange head bolts, mount the motor to the airlock gearbox. Place the specified sprocket on to the airlock shaft and align to sprocket on gearbox. (See Figure 7I.)

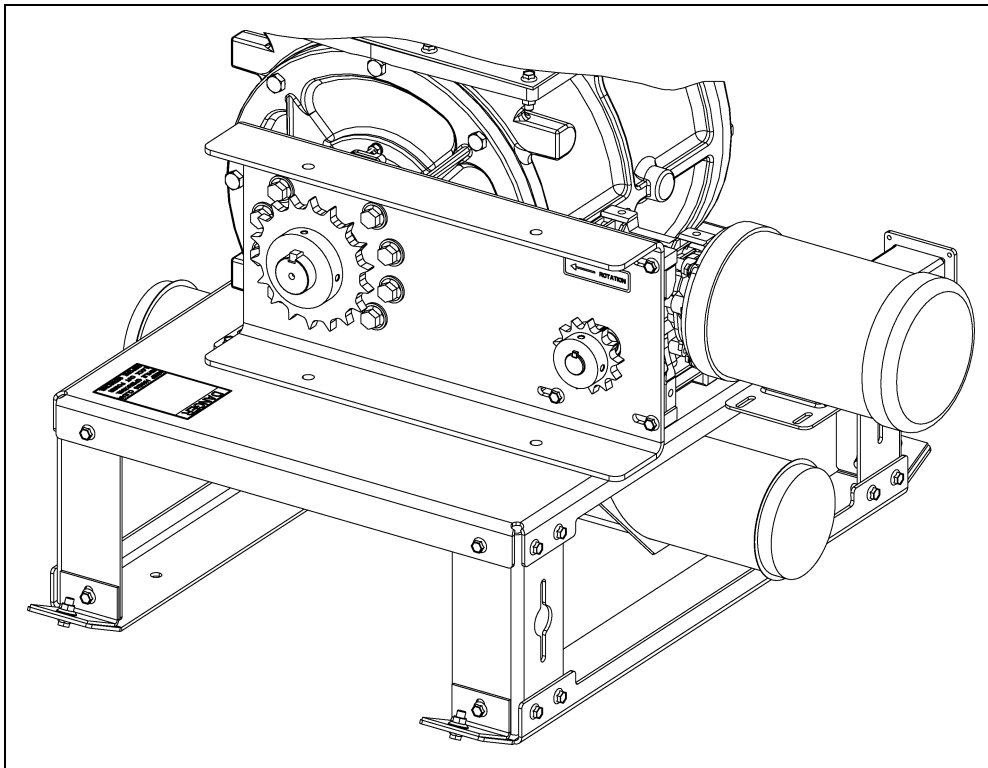

Figure 7I

7. Assembly

- Next, install the chain on to the sprockets and apply tension by sliding the gearbox to the right. Tighten the four (4) 3/8" flange bolts on the two (2) drive mount bars. (See Figure 7J.)

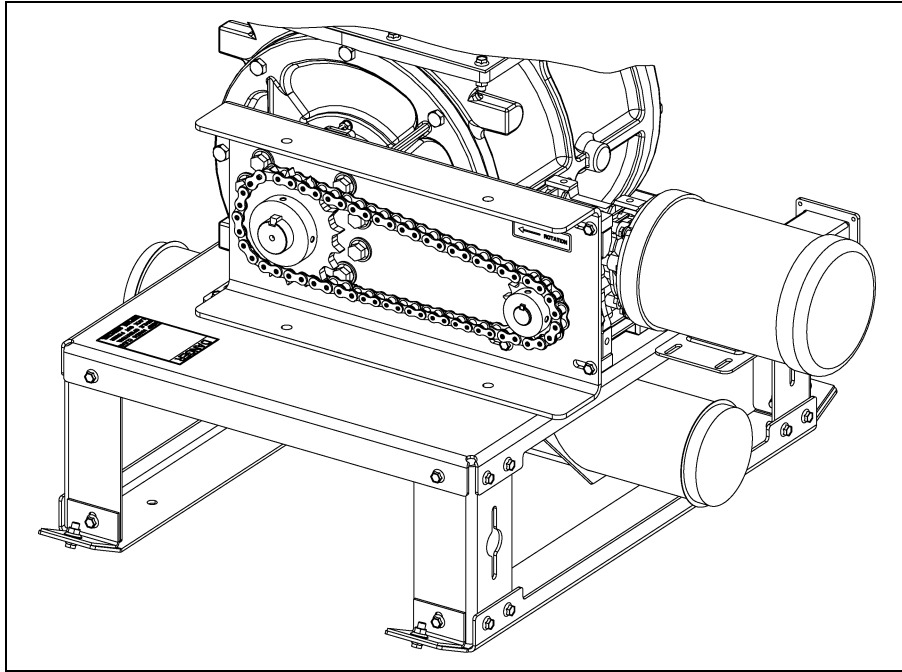

Figure 7J

- Remove 1/4" pipe plug in gate valve pipe. Install gauge assembly and attach air hose. (See Figure 7K.)

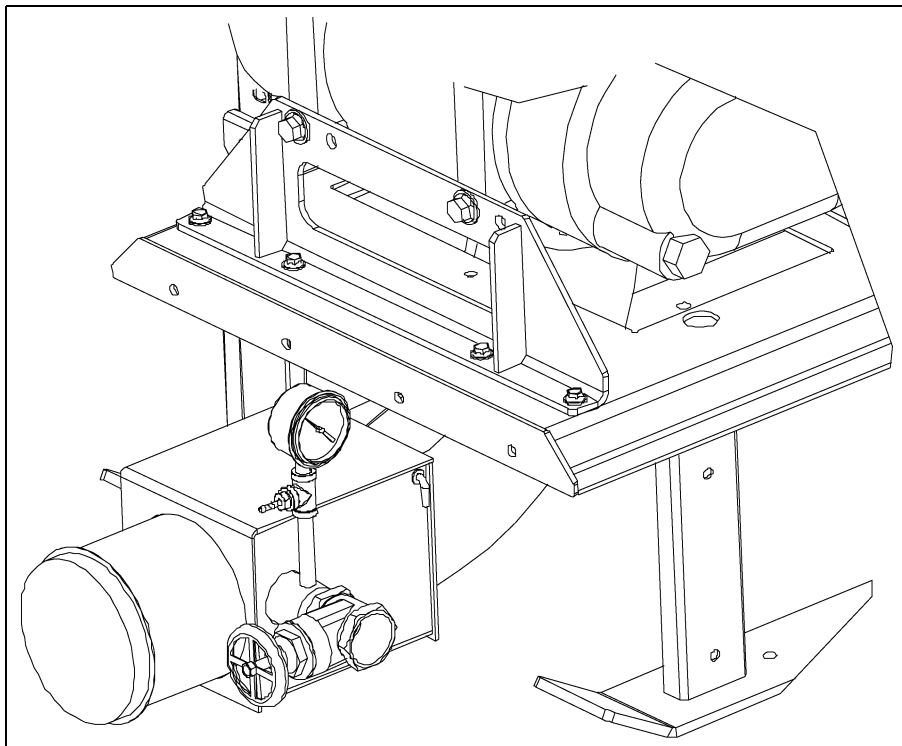

Figure 7K

THE SET-UP OF THE PNEUMATIC AIR SYSTEM IS NOW COMPLETE.

6" Air System 2100 Motor Mounting Locations

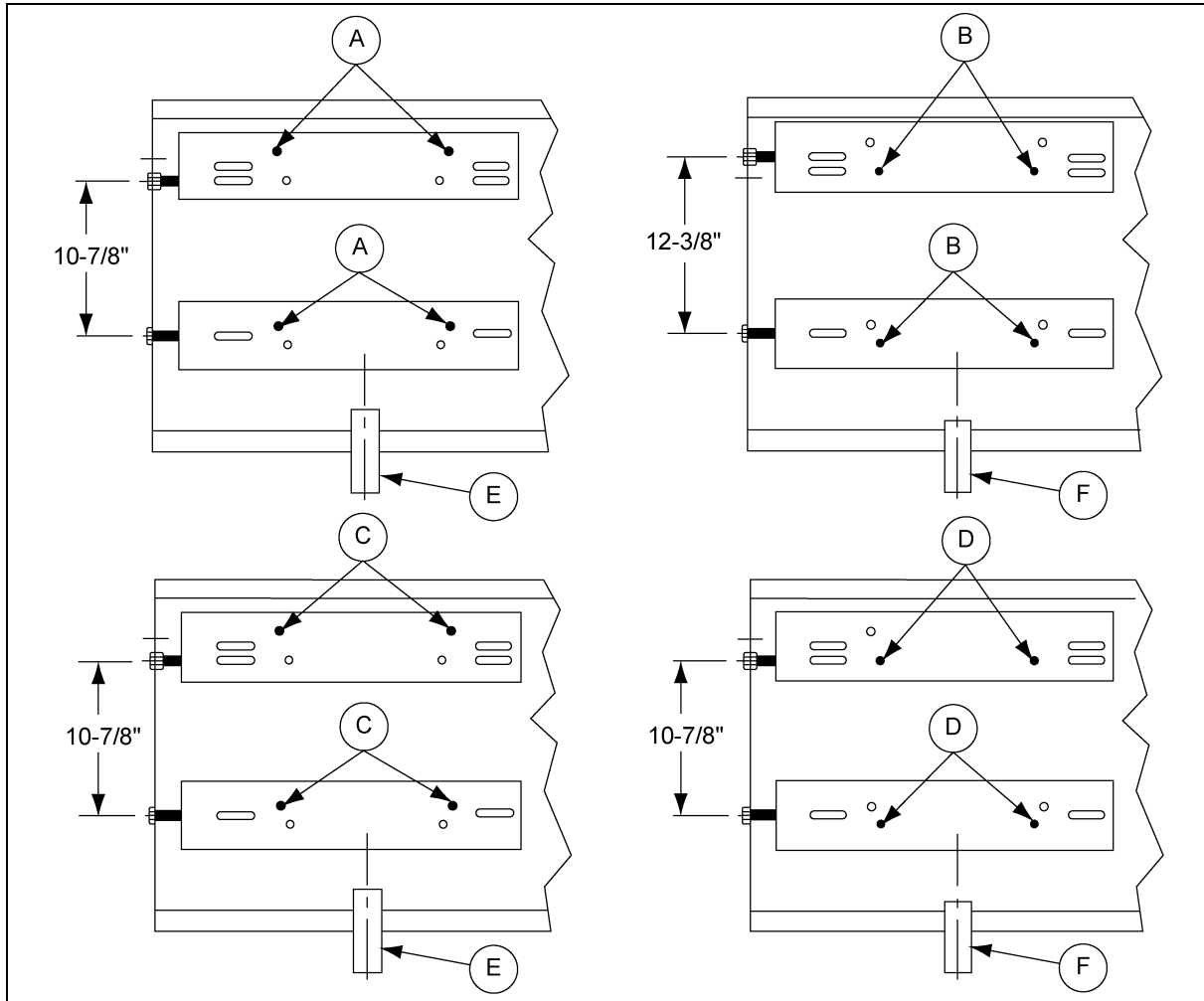

Figure 7L

Ref #	Description
A	365T Frame
B	326T Frame
C	364T Frame

Ref #	Description
D	324T Frame
E	2-3/8" Diameter
F	2-1/8" Diameter

6" Air Systems Motor Chart

Motor Part #	Horsepower	Frame Size	Shaft Diameter	Voltage	Phase
MTR-0061	40	324TS	1-7/8	230/440	3
MTR-0065	50	326TS	1-7/8	230/440	3
MTR-0068	60	364TS	1-7/8	230/440	3
MTR-0105	75	365TS	1-7/8	230/440	3

NOTE: Motor rotation is counterclockwise as viewed from the shaft end.



Be sure to install motor sheave so bushing is on the inside towards the motor.

Air System Control Box Definitions

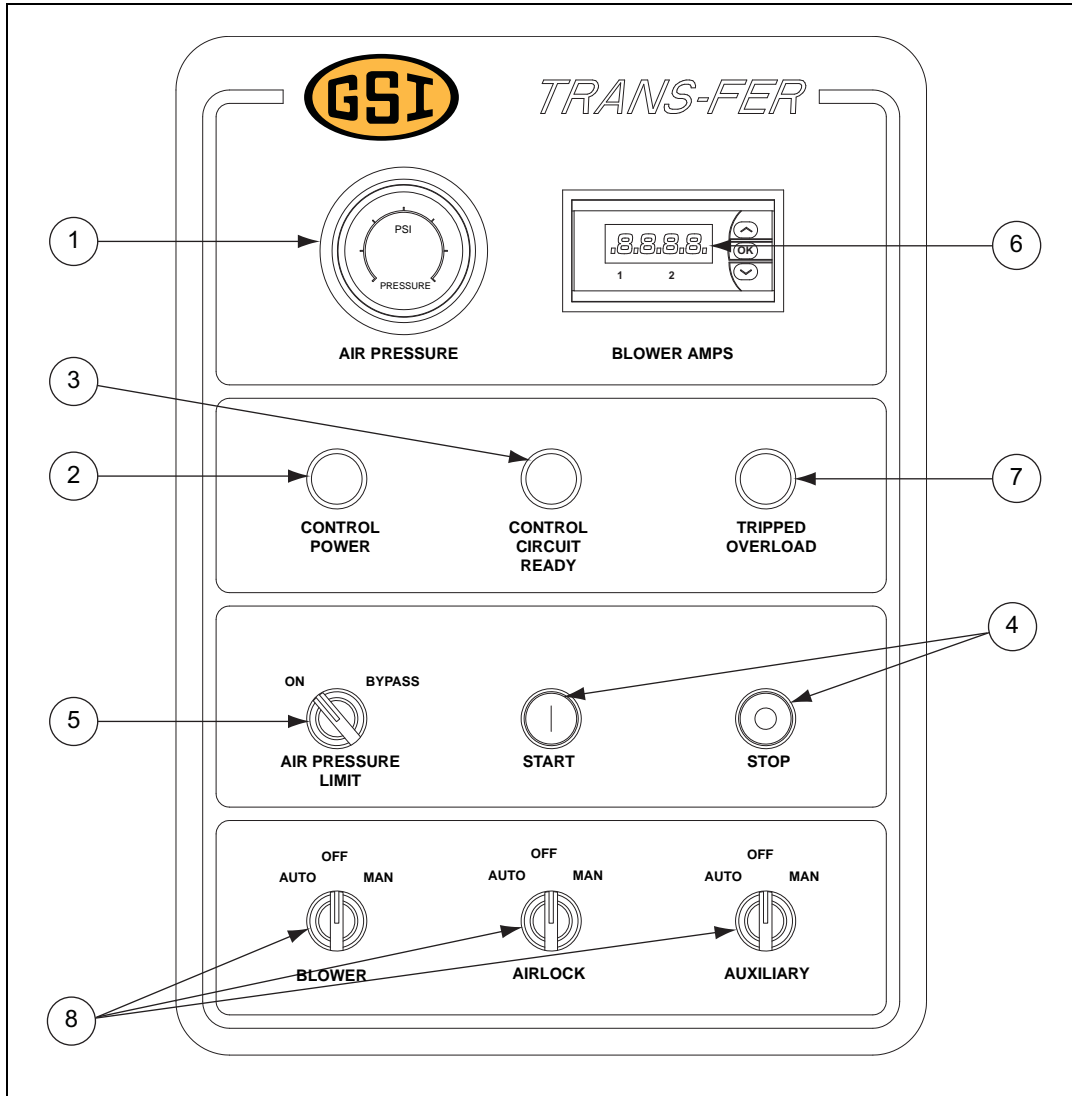

Figure 7M

Ref #	Description
1	Air Pressure Gauge
2	Power "ON" Indicator Light
3	Control Circuit Ready Indicator Light
4	Start/Stop Switch
5	Air Pressure Limit
6	Digital Amp Meter
7	Tripped Overload Indicator Light
8	Control Switches

Control Overview

The redesigned control box for Air Systems now incorporates short circuit protection for each motor branch circuit. This is provided with circuit breakers which are the same as used in the portable dryers. In addition, the contactors and overloads are now IEC style controls (portable dryer parts also). This removes the need for separate thermal heater strips for the overloads. Be aware that the power connections to the new style box are different. The incoming power still enters at the lower right bottom of the box. The output power for the motors and remote control connections now exit the bottom of the box.



Confirm that the overloads are set to the values shown on the “Overload Set Chart” on Page 27 before operating the system.

The remaining operations are the same as the previous control box design.

1. **Air Pressure Gauge:** This gauge indicates the system air pressure.
2. **Power “ON” Indicator Light:** This lamp will illuminate when power is supplied to the control box.
3. **Control Circuit Ready Indicator Light:** This lamp will illuminate when the Start button has been pushed and all control circuits are completed. When lit and in the automatic mode, the Air System will run whenever it receives a signal to start.
4. **Start/Stop Switch:** The Start button must be pushed before any part of the Air System can be run. Pushing the Stop button will immediately stop all functions.
5. **Air Pressure Limit Control Switch:** When in the “ON” position, this switch will allow the Air Pressure switch to immediately shut down the Air System whenever the air pressure exceeds preset conditions.
6. **Amp Meter:** The amp meter measures the current flow to the blower motor.
7. **Tripped Overload Indicator Light:** This lamp will illuminate when any of the motor thermal overloads in the control box has tripped. The overloads for all three (3) circuits (aux, airlock and blower) must have thermal overloads installed to operate the system. See thermal unit chart [on Page 27](#).
8. **Control Switches:** The operation of the blower, airlock and auxiliary equipment of the Air System is controlled by placing these switches in the “AUTO”, “MANUAL” or “Off” POSITION.
9. **Automatic Control Terminals:** When the Air System is ready to run (i.e., the control ready light is ON), the system can then be started and run by completing the circuit between terminals 1 and 2. The blower, airlock or auxiliary equipment will not run in the automatic mode unless terminals 1 and 2 are connected. For example, a closing set of contacts in a dryer control box would complete the circuit between terminals 1 and 2 and automatically start the Air System.
(See [Figure 7N on Page 26](#).)



No voltage should be supplied to terminals 1 and 2. (See wiring diagram on Page 28.)

10. **Remote Shut Down Control:** A remote piece of equipment can be caused to shut down with the Air System by putting terminals 3 and 4 in series with the control circuit of the remote equipment. This circuit has a maximum current rating of 10 amps. The circuit between terminals 3 and 4 is closed whenever the control circuit ready light is ON, regardless of the position of the control switches (“AUTO”, “OFF” or “ON”). See figures [on Page 28 and Page 32](#).

7. Assembly

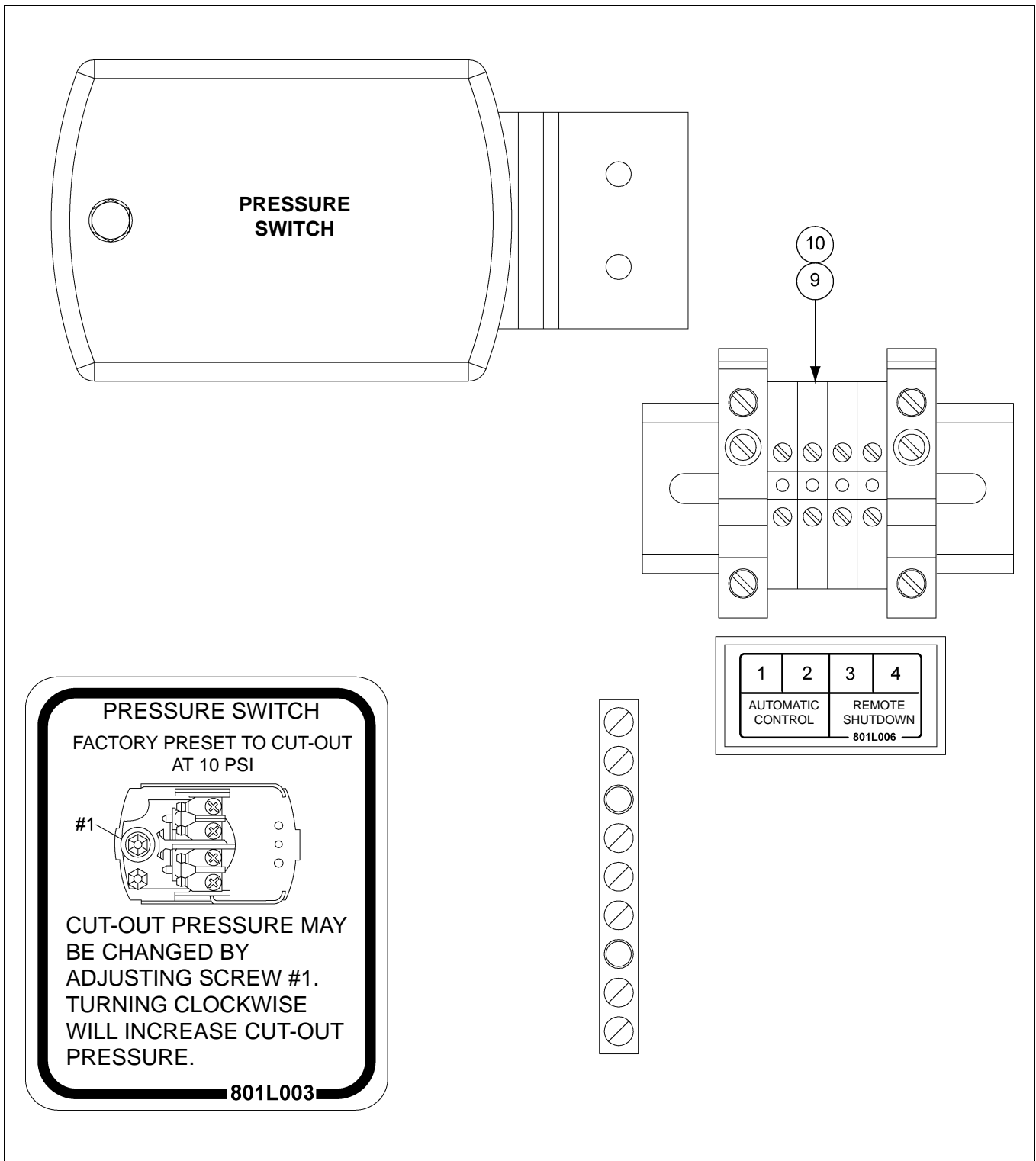

Figure 7N Auto Remote

Ref #	Description
9 and 10	Automatic Control Terminals and Remote Shut Down Control

6" Overload Set Chart

Single Motor	AS-0471 Airlock O/L Relay 2.5-4.0 Amps	056-1968-9 Auxiliary O/L Relay 4.0-6.0 Amps	056-1945-7 Airlock O/L Relay 1.6-2.5 Amps	056-1945-7 Auxiliary O/L Relay 1.6-2.5 Amps	AS-0752 Blower O/L Relay 37.0-50.0 Amps	D03-0984 Blower O/L Relay 48.0-65.0 Amps	CH-1060 Blower O/L Relay 48.0-65.0 Amps	CH-1062 Blower O/L Relay 63.0-80.0 Amps	AS-0773 Blower O/L Relay 60.0-100.0 Amps	056-2276-6 Blower O/L Relay 90.0-150.0 Amps	AS-0764 Blower O/L Relay 90.0-150.0 Amps	056-2244-4 Blower O/L Relay 132.0-220.0 Amps
AS-0671 Control Package - 40 HP 230V-3 PH	3.7	4.8								95		
AS-0682 Control Package - 40 HP 460V-3 PH			1.7	2.1		51						
AS-0708 Control Package - 40 HP 575V-3 PH			1.4	1.8	42							
AS-0672 Control Package - 50 HP 230V-3 PH	3.7	4.8								112		
AS-0683 Control Package - 50 HP 460V-3 PH			1.7	2.1			55					
AS-0709 Control Package - 50 HP 575V-3 PH			1.4	1.8	45							
AS-0673 Control Package - 60 HP 230V-3 PH	3.7	4.8									132	
AS-0684 Control Package - 60 HP 460V-3 PH			1.7	2.1				66				
AS-0710 Control Package - 60 HP 575V-3 PH			1.4	1.8			54					
AS-0686 Control Package - 75 HP 230V-3 PH	3.7	4.8										166
AS-0685 Control Package - 75 HP 460V-3 PH			1.7	2.1					83			
AS-0711 Control Package - 75 HP 575V-3 PH			1.4	1.8					68			

9. Schematic Diagram

Schematic - 230V/460V/575V-3 PH

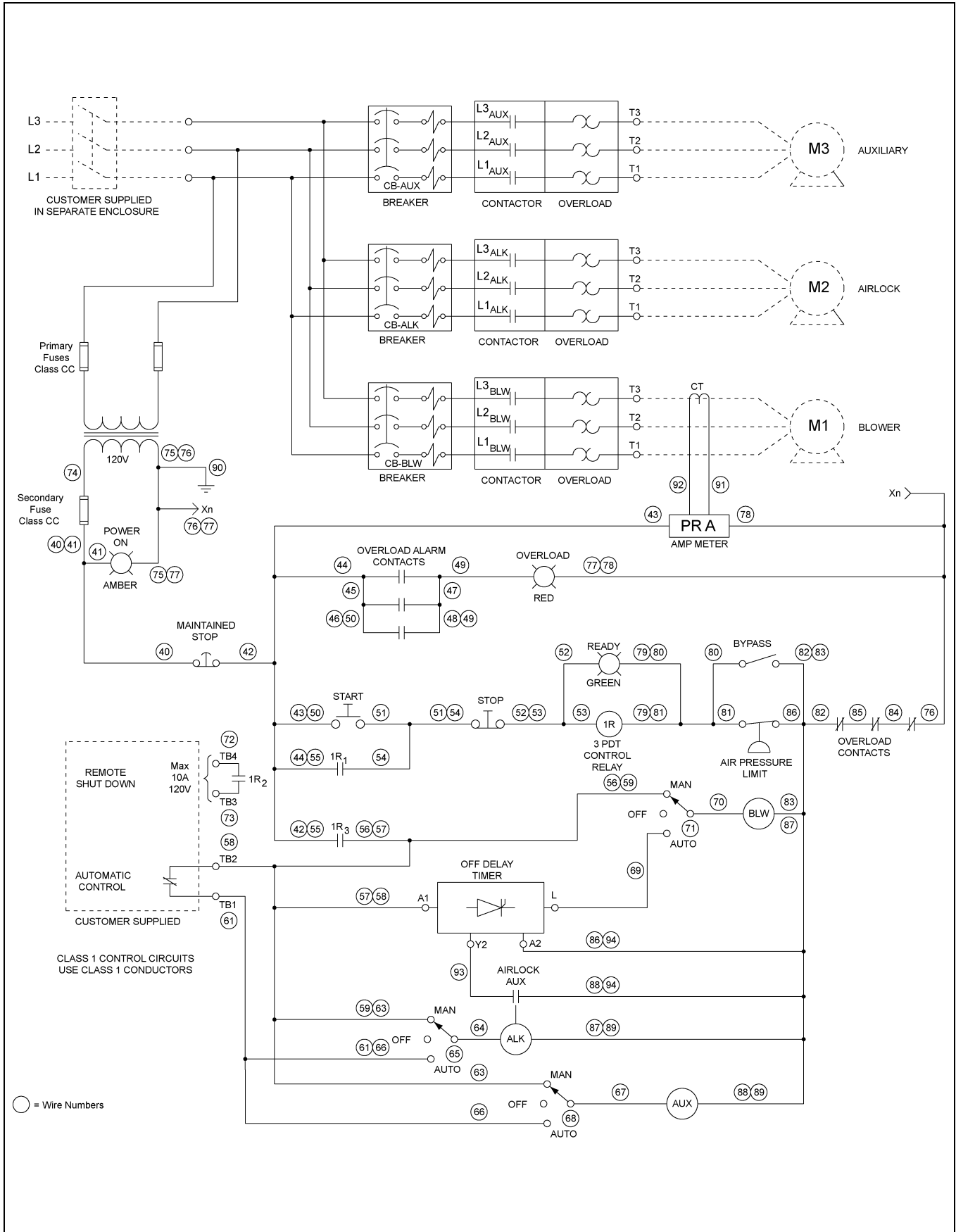

Control Box Operational Procedures

Automatic operation using the automatic controller unit tied to terminals 1 and 2.

1. Switch all circuit breakers to the “ON” position.
2. Place the Blower, Airlock and Auxiliary Control switches in the “OFF” position.
3. Place the Air Pressure Limit Control switch in the “ON” position (unit will stop when the air pressure reaches 10 PSI).
4. Turn ON the power to the Air Systems control box. The power light should come ON.
5. Push the Start button; the control circuit ready light should come ON.
6. Place the Blower, Airlock and Auxiliary switches in the “AUTO” position.
7. The complete Air System will now run when the automatic controller completes the circuit between terminals 1 and 2. When this circuit is broken, the airlock and auxiliary equipment will stop immediately, but the blower will continue to run for an additional 15 seconds to clear the tubing in the system.
8. The airlock, auxiliary equipment and blower will run when the control switches are placed in the “MANUAL” mode. The airlock, auxiliary equipment and blower will stop immediately when switched “OFF”.
9. Pushing the Stop button will immediately stop all Air System functions as well as any equipment tied to terminals 3 and 4.

Operation of the Air System WITHOUT an automatic controller tied to terminals 1 and 2.

1. Switch all circuit breakers to the “ON” position.
2. Place the Blower, Airlock and Auxiliary Control switches in the “OFF” position.
3. Place the Air Pressure Limit Control switch in the “ON” position (unit will stop when the air pressure reaches 10 PSI).
4. Turn ON the power to the Air System control box; the power light should come ON.
5. Push the Start button. The control circuit ready light should come ON.
6. The blower, airlock and auxiliary equipment can now be run by placing them in the “MANUAL” position. The airlock, auxiliary equipment and blower will stop immediately when switched OFF.
7. Pushing the Stop button will immediately stop all Air System functions as well as any remote equipment tied to terminals 3 and 4.

Air System Operation Guidelines

1. Be aware of the quality of grain that is entering and leaving the Air System. Grain damage can occur with any pneumatic system unless care is taken to adjust the velocity of the grain. This can be done by opening or closing the outlet gate valve on the blower outlet of the Air System. Opening the valve will let air out of the tubing system which will slow the velocity of the air and grain in the tubing system. A recommended procedure is to open the valve slowly until the line pressure begins to surge and then to close it by 1/2 turn. This will provide the slowest possible grain velocity for any tubing system. This procedure for adjusting the air velocity should be repeated for each different tubing layout and capacity change.
2. If the tubing system should become plugged, place the Air Pressure Limit switch to the "OFF" position, switch the airlock and auxiliary equipment to "OFF" and the blower to "MANUAL". Note the opening of the outlet gate valve, then open it completely so all the air is exhausted when the blower is started. Push the Start button and the blower will start. Slowly close the outlet gate valve until the grain starts moving and clears the tube. Adjust the valve as explained in [Step 1](#). It should be the same as noted before adjusting. Operate the airlock and auxiliary equipment in "MANUAL" until all grain is out of the system.



Do not stand next to the exhausted air.

3. The Air Pressure Limit switch should always be in the "ON" position during routine operation to provide protection to the blower against overload conditions. The air pressure limit is set at the factory to shut down the system at 10 PSI. If adjustment is needed, rotate the adjusting screw counterclockwise to lower the pressure limit or clockwise to increase the pressure limit. A one-half (1/2) turn of the screw will change the pressure limit 1 PSI.

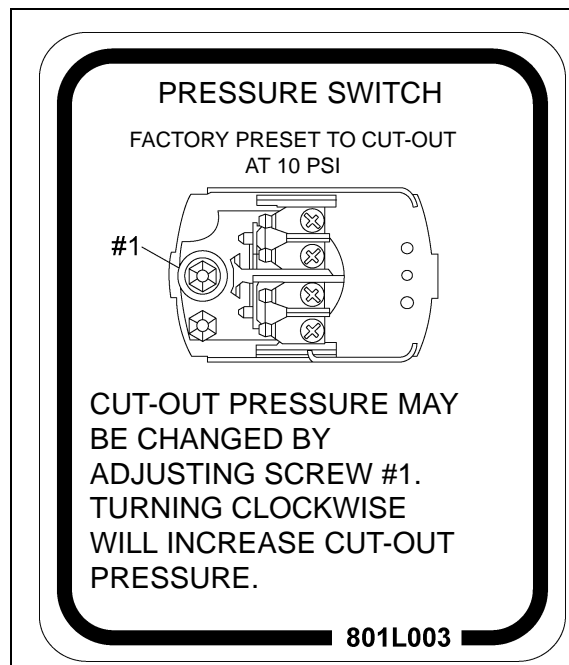

Figure 10A

NOTE: *If the pressure limit is set below 5 PSI, the switch may not reset and allow the air transfer to run. (See [Figure 10A](#).)*

4. The air filter element should be inspected daily and cleaned when required. Both the poly foam pre-filter and the filter element can be cleaned by blowing air through them or washing them with mild detergent and water. A restricted air filter will cause a system to become plugged. It should always be inspected whenever plugging occurs.
5. The airlock is provided with a housing that incorporates grain shear protection to prevent grain damage.

6. GUIDELINES FOR OPERATION OF AIR SYSTEMS

- a. Grain in a pneumatic Air System running at full capacity will move at about 60% of the air speed. A system operating at low capacities will move grain at 80%-90% of the air speed.
- b. Decreasing the amount of air in the system (opening the hand gate valve) will cause the grain to move slower and also cause the air pressure to rise. (Essentially, the grain is causing the air to “pile up”.)
- c. Increasing the air in a system (closing the gate valve) will increase the grain velocity and lower the pressure.

7. RECOMMENDATIONS FOR OFF-SEASON STORAGE

The blower and airlock have precision machined components and must be protected to prevent corrosion and rust from forming on the blower lobes and airlock vanes. These parts should be coated with motor oil after each drying season. (Spray lubricants such as WD-40 do not usually provide adequate protection.)

Both the airlock and blower assemblies should be carefully protected from the weather and the piping system disconnected from the blower and airlock. Remove the transition connection to the airlock inlet and re-install the weather cover shipped with the airlock. This is important to prevent condensation from collecting in the airlock and blower.

Wiring for a surge tank hooked to an Air System

The Air System will start when both P_1 and P_2 are closed. As it empties, P_1 will open but will not stop the unit due to auxiliary contacts being closed. When P_2 opens, the unit will stop.

NOTE: Be sure the auxiliary switch is in the "AUTO" position.

P_1 and P_2 are pressure switches.

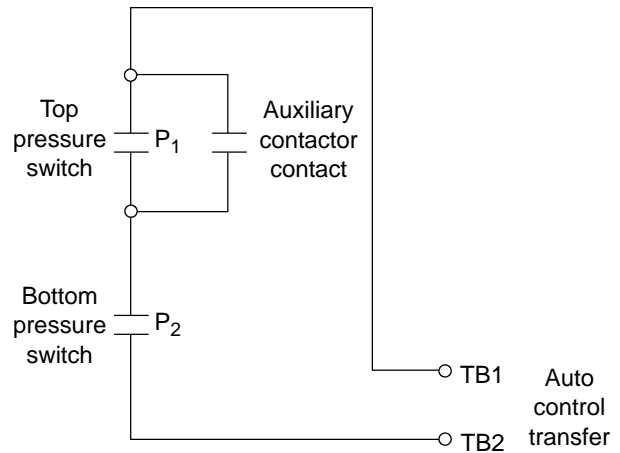

How to hook-up Air System to remote equipment

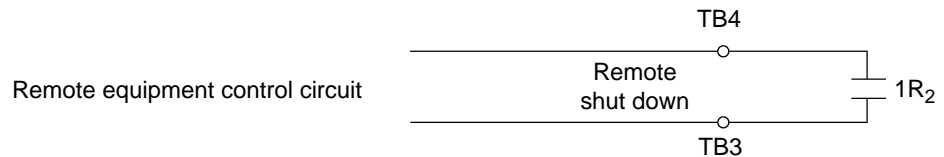

Any contact that closes upon start and opens on stop.
(NOTE: This contact must not have any external AC power.)

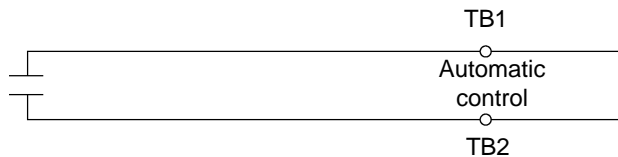

With the above hook-up, the Air System must be started before the remote equipment. If the Air System is manually turned OFF or shut down from high pressure or an overload, the remote equipment will also shut down.

TB3 and TB4 will have a closed contact ($1R_2$) as long as the Air System has the "ready" indicator (located in the control box) ON. The automatic control TB1 and TB2 requires a closed contact across them to start the Air System unit.

Programming Parameters for PR Electronics 5714A

To begin programming: Turn power ON, then press OK.

Ref #	On Display	Action	Set to Value	End
1	IN	Press either Arrow	CURR	Press OK
2	RANG	Press either Arrow	4-20	Press OK
3	DEC.P	Press either Arrow	<i>See Note 1</i>	Press OK
4	DI.LO	Press either Arrow	0	Press OK
5	DI.HI	Press either Arrow	<i>See Note 2</i>	Press OK
6	EPAS	Press either Arrow	No	Press OK
7	-	END of Inputs		

NOTES:

1. This parameter determines the location of the decimal point in the displayed value. This should be set to 11.11 for values of 10-99 and 111.1 for values greater than 100.
2. This parameter determines the scale of the displayed value and should be matched to the control transformer range setting such as 30, 60, 120 for H921 or 200 for 721HC.

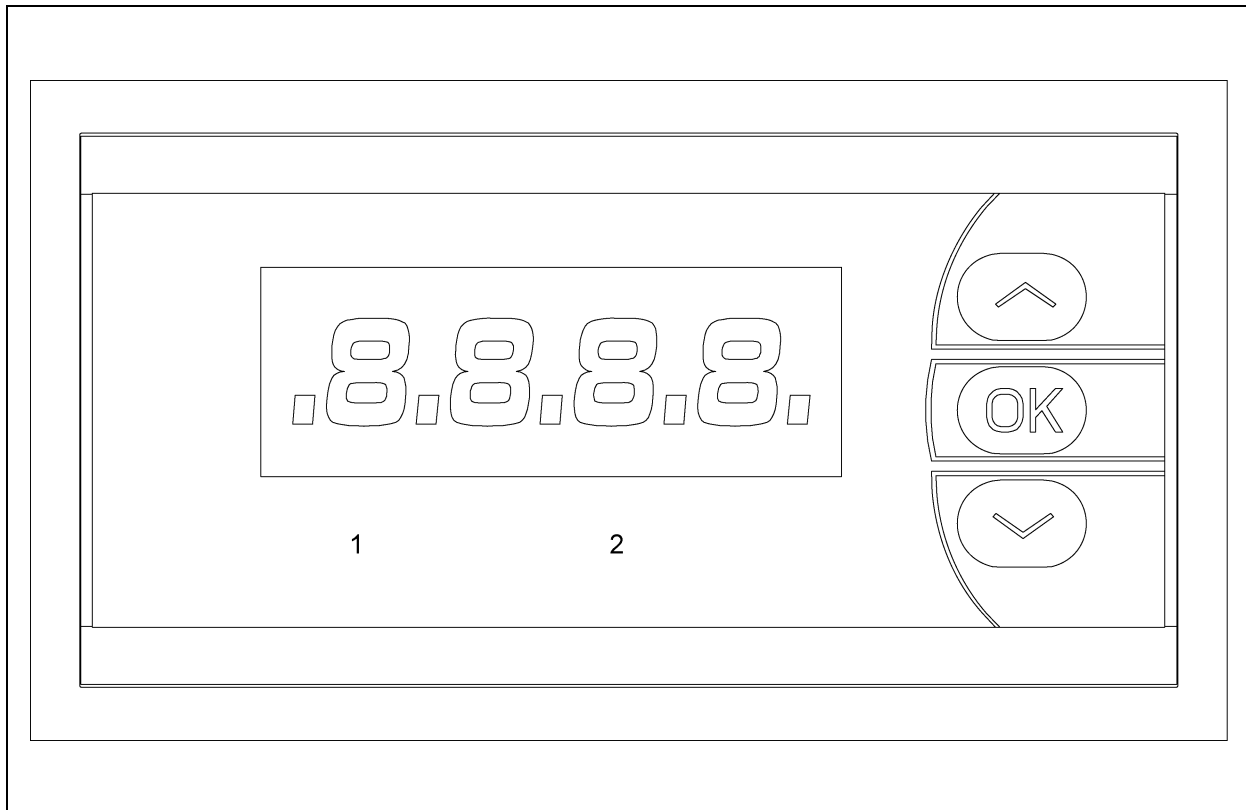
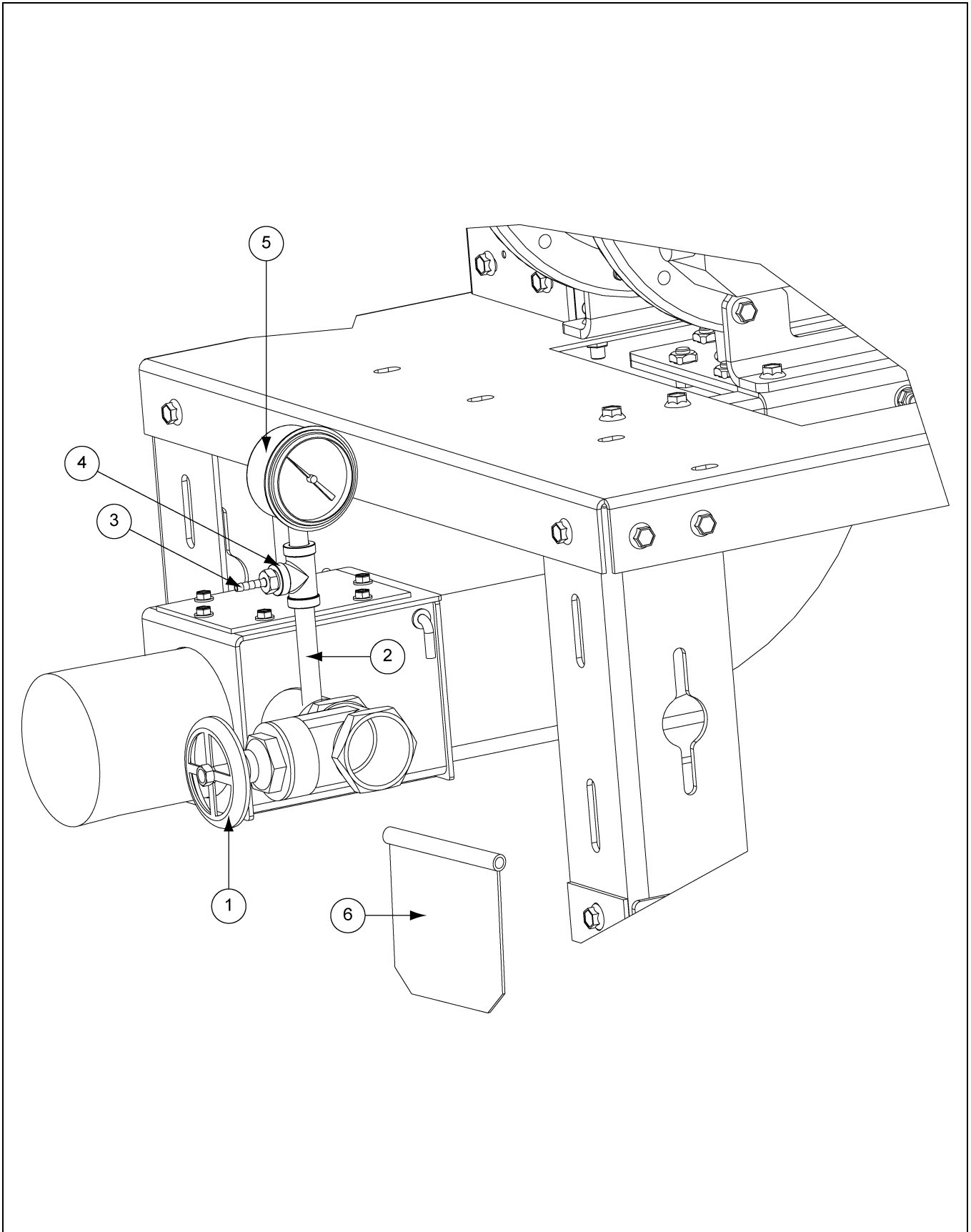

Figure 11A Blower Amps

NOTES

1. **Blower Outlet Parts** - *(See Page 36 and 37.)*
2. **6" (2100) with 3500 RPM Motors Blower Parts** - *(See Page 38 and 39.)*
3. **Blower Filter Parts** - *(See Page 41.)*
4. **6" Airlock Parts** - *(See Page 42 and 43.)*
5. **Airlock Inlet Transition Assembly** - *(See Page 44.)*
6. **Inner Door Assembly** - *(See Page 45.)*
7. **Control Panel Parts 230V - 3 PH** - *(See Page 46 and 47.)*
8. **Control Panel Parts 460V - 3 PH** - *(See Page 48 and 49.)*
9. **Control Panel Parts 575V - 3 PH** - *(See Page 50 and 51.)*

Blower Outlet Parts



Blower Outlet Parts List

Ref #	Part #	Description	Qty		
			4"	5"	6"
1	PT1132	Gate Valve, 1-1/2" NPT	1	1	1
2	4FH0509	Pipe Nipple, 1/4" NPT x 3 Galv SCH 40	1	1	1
3	4FH0971	Hose Barb, 1/4" x 1/4" MPT Brass	1	1	1
4	4FH0581	Pipe Tee, 1/4" FPT Galv	1	1	1
5	PT1127	Gauge, Oil Filled 0-15 PSI	1	1	1
6	8021235	Check Valve Plate Weld - 4"	1		
6	8021235	Check Valve Plate Weld - 5"		1	
6	8041200	Check Valve Plate Weld - 6"			1

12. Parts List

6" (2100) with 3500 RPM Motors Blower Parts

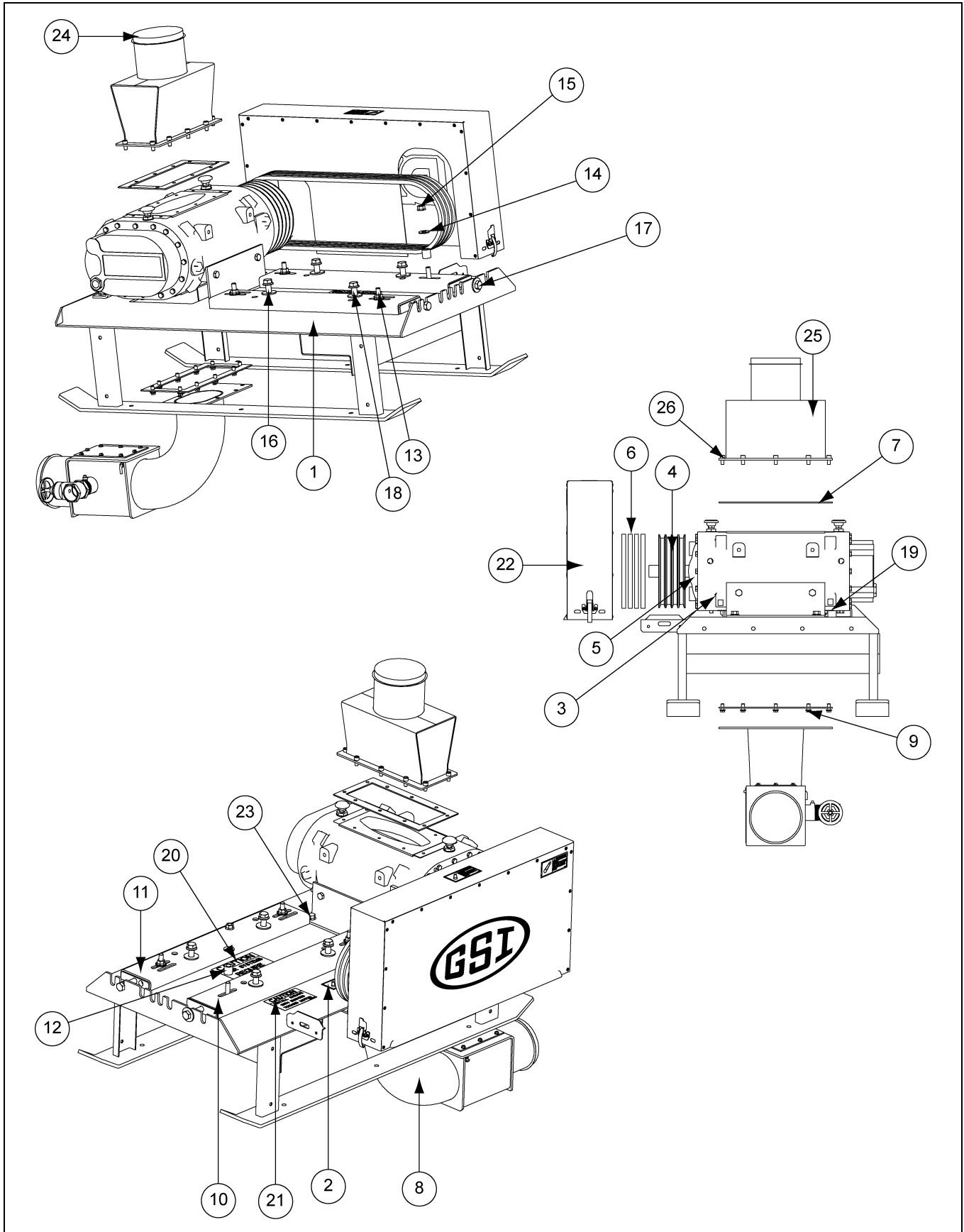

6" (2100) with 1760 RPM Motors Blower Parts List

Ref #	Part #	Description	Qty		
			4"	5"	6"
	AS-0126-GD	Air System - 6" Blower 40 HP	X		
	AS-0129-GD	Air System - 6" Blower 50 HP-60 HP		X	
	AS-0130-GD	Air System - 6" Blower 75 HP			X
1	AS-0207-BS-GD	Blower Base Weld - 6" 3500 RPM Bin Silver GD	1AR	1AR	1AR
2	DC-994	Decal - Danger Shear Point	1	1	1
3	AS-0883	Blower-6" High-Capacity, GD Duro Flow 4512	1AR	1AR	1AR
4	GC06676	Sheave, 4 GR, A7.6-B8.0 - SK, 8.35" O.D.	1		
4	MHC00791	Sheave, 5 GR, A8.2-B8.6 - 2517 TL, 8.95" O.D.		1	
4	MHC01829	Sheave, 6 GR, A7.6-B8.0 - 2517 TL, 8.35" O.D.			1
5	GC06687	Bushing SK x 1-7/16" Bore	1		
5	CE-00597	Bushing, 2517 x 1-7/16" TL		1	1
6	MHC00616	V-Belt BX 66	4	5	6
7	804A114	Gasket, 6" Roots-Flo	2	2	2
8	8041165	Blower Outlet Elbow Assembly - 6"	1	1	1
9	S-9067	Flange Bolt 3/8"-16 x 3/4" ZN Grade 5	10	10	10
10	804A066-BS	Motor Adjust Rail - 6" R.H.	1	1	1
11	804A068-BS	Motor Adjust Rail - 6" L.H.	1	1	1
12	801A116-BS	Motor Mount Spacer - Blower	4	4	4
13	2FH0677	Carriage Bolt 1/2"-13 x 2-1/2" ZN Grade 5	4	4	4
14	S-2120	Flat Washer 1/2" SAE ZN	4	4	4
15	S-8506	Flange Nut 1/2"-13 ZN	8	8	8
16	S-858	Flat Washer 5/8" USS ZN Grade 2	5	5	5
17	2FH1043	Bolt, HHTB 5/8"-11 x 3-1/2" ZN Grade 2	2	2	2
18	S-9264	Flange Bolt 5/8"-11 x 2" ZN Grade 5	4	4	4
19	S-4110	Hex Nut 5/8"-11 YDP Grade 5	1	1	1
20	DC-1867	Decal, Caution - Requires 3500 RPM Motor	1	1	1
21	DC-1869	Decal, Caution - Install Sheave	1	1	1
22	AS-0251	Blower Shield Assembly 6" Air System	1	1	1
23	S-9062	Flange Bolt 1/2"-13 x 1-1/4" ZN Grade 5	4	4	4
24	MS5395	Cap, Plastic FTS 6" I.D. Tube Orange	2	2	2
25	8041144-Y	Blower Inlet Weld - 6" Ochre	1AR	1AR	1AR
26	S-8898	Screw, MS 3/8"-16 x 3/4" SHCS	10	10	10
N/S	804A110	Filter Base Assembly - 6"	1	1	1
N/S		Filter Element - 4" and 5" Air System	2	2	
N/S	804A086-Y	Air Filter Canister Weldment - 6" Painted Ochre	1	1	1
N/S	804A015	Coupler Compression 6" 5 Bolt	1	1	1
N/S	4000-3	Motor, 40 HP 3 PH 1750 2-1/8"	1	1	1
N/S	6000-3-3500	Motor, 60 HP 3 PH 3500 1-7/8"	1	1	1

Motors and Drive Parts (Not Shown)					
Part #	Description	Qty			
MTR-0061	Motor 40 HP 3 PH 3500 RPM	X			
MTR-0065	Motor 50 HP 3 PH 3500 RPM		X		
MTR-0068	Motor 60 HP 3 PH 3500 RPM		X		
MTR-0105	Motor 75 HP 3 PH 3500 RPM			X	
GC06676	Sheave, 4 GR, A7.6-B8.0 - SK, 8.35" O.D.	X			
MHC00170	Bushing, 3020 x 1-7/8" TL	X			
MHC01408	Sheave, 5 GR 5V 11.8-3020 TL		X		
CE-00598	Bushing, 2517 x 1-7/8" TL		X	X	
MHC01829	Sheave, 6 GR, A7.6-B8.0 - 2517 TL, 8.35" O.D.			X	

12. Parts List

If replacing a roots-flo blower, use the following chart to determine the appropriate service kit.

Service Kit Cross Reference Sheet

System Size	Series	Kit PN to be Ordered	Drive	HP	Line Items to be Ordered with Kit		Qty
4" Systems	All	AS-0889	Single	All	MHC00113	Blower Sheave	1
					MHC00742	Blower Bushing	1
			Twin	All	MHC00771	Blower Sheave	1
					MHC00742	Blower Bushing	1
5" Systems	1200 Series	AS-0890	Single	20	MHC00717	Motor Sheave	1
					MHC00024	Motor Bushing	1
				30	MHC00717	Motor Sheave	1
			CE-00598		Motor Bushing	1	
			Twin	10	MHC00110	Motor Sheave	2
					MHC0065	Motor Bushing	2
	15	MHC00110		Motor Sheave	2		
		MHC00024	Motor Bushing	2			
1700 Series	AS-0891	All	All	None	-	0	
6" Systems	All	AS-0892	Single	40	GC06676	Motor Sheave	1
				75	MHC01829	Motor Sheave	1
					CE-00598	Motor Bushing	1
				50-60	MHC01420	Motor Sheave	1
					CE-00598	Motor Bushing	1
					MHC00791	Blower Sheave	1
					CE-00597	Blower Bushing	1

* For example: To order a service kit for a 6" 2100 series, single drive, 75 HP air system, you must order 1, AS-0892, 1, MHC01829 and 1, CE-00598.

Blower Filter Parts

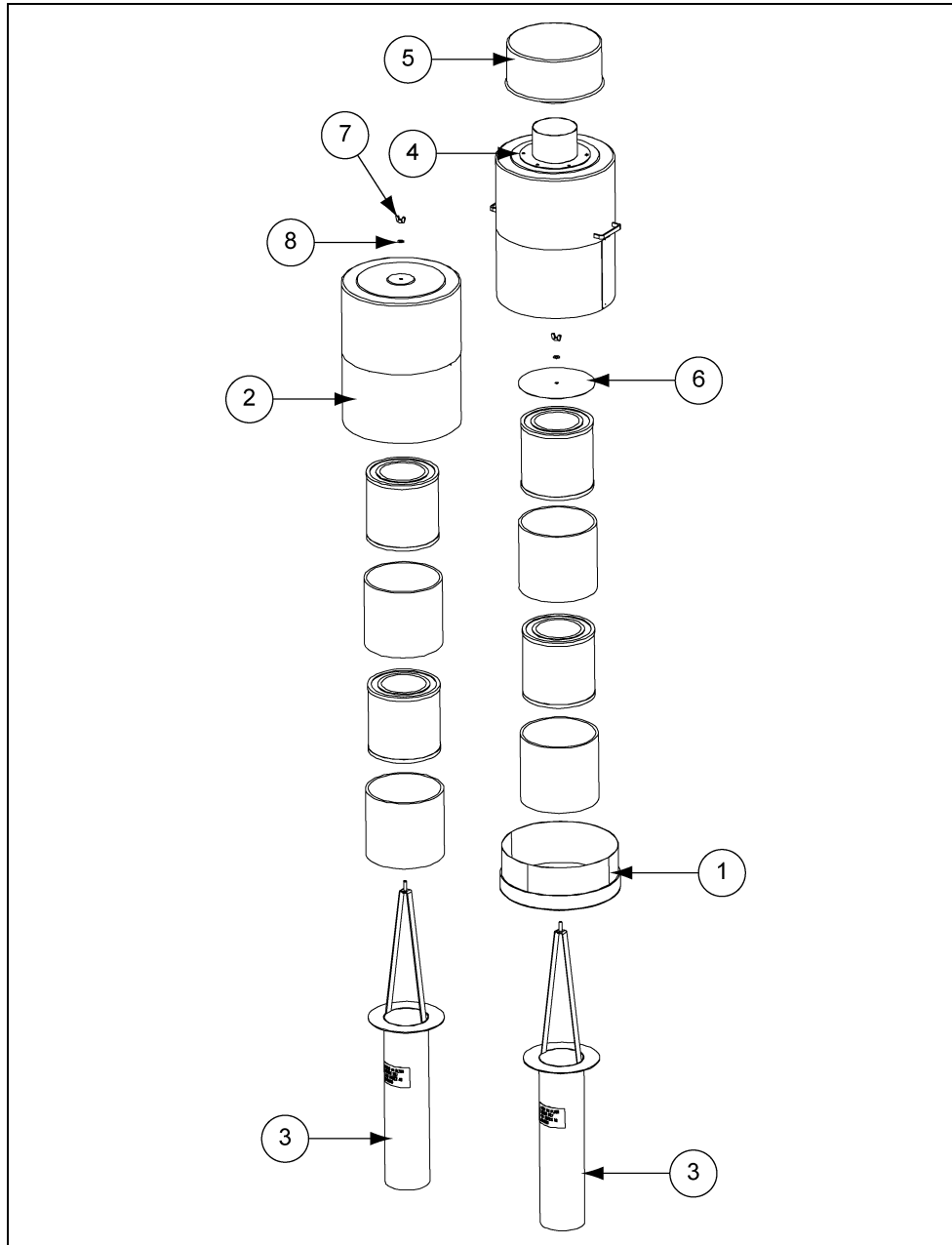

Blower Filter Parts List

Ref #	Part #	Description	Qty
1	8041190-Y	Pre-Cleaner Base Weldment - 6" Painted Ochre	1
2	804A086-Y	Air Filter Canister Weldment - 6" Painted Ochre	1
3	804A110	Filter Base Assembly - 6"	1
4	8041187	Pre-Cleaner Canister Assembly - 6"	1
5	MS5467	Pre-Cleaner - 6" Inlet Centri #EX-60 (500-950 CFM)	1
6	8021228	Filter Top Plate - 4", 5" and 6" Pre-Cleaner	1
7	S-1451	Wing Nut 3/8"-16 UNC ZN Plated	1
8	S-248	Flat Washer 3/8" USS ZN YDP Grade 2	1

6" Airlock Parts

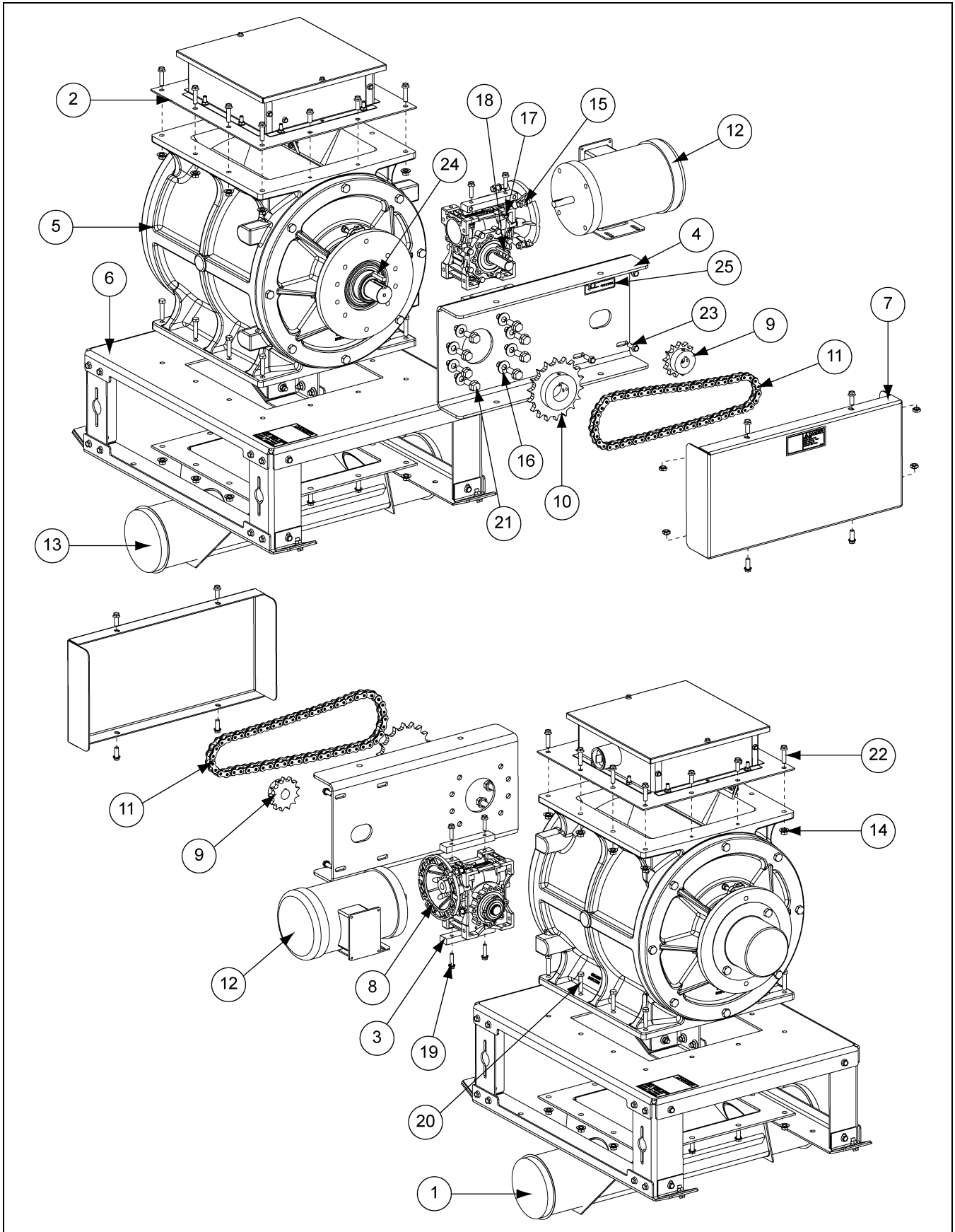

6" Airlock Parts List

Ref #	Part #	Description	Qty
1	8041210-BS	Airlock Hopper Weld - 6"	1
2	AS-0916	Airlock Inlet Assembly - 6"	1
3	AS-0901-BS	Airlock, Drive Mount Bar	2
4	AS-0902-Y	Airlock, Drive Mount Plate Weld Ochre	1
5	AS-0906	Airlock, 6" Air System, 14" MFT	1
6	AS-0919	Airlock, Meyer Base Assembly - 6"	1
7	AS-0928	Airlock, Drive Cover Assembly	1
8	AS-0916	Gearbox, NMRL-P063 with Limiter, 30:1, 56C, 1.0" Shaft	1
9	AS-0920	Sprocket, #60 13T 1" Bore with Set Screws	1
10	AS-0922	Sprocket, #60 24T 1-3/4" Bore with Set Screws, 2100 Systems	1
11	AS-0929	Chain, Roller #60 56 Pitch (42") 2100 Systems	1
12	MTR-0184	Motor, 1 HP 1 PH 1725 RPM, 60 HZ 115/230V 56C Frame	1
12	FLX-3550	Motor, 1 HP 3 PH 1725 RPM, 60 HZ 208-230/460V 56C Frame	1
13	MS5395	Cap, Plastic 6" I.D. Tube Orange	2
14	S-968	Flange Nut 3/8"-16 ZN Grade 5 Wide Flange	16
15	S-1054	Lock Washer 3/8"	4
16	S-2120	Flat Washer 1/2" SAE ZN	8
17	S-3611	Flange Nut 5/16"-18 YDP Grade 2	4
18	S-4513	Key, 1/4" x 1/4" x 2" Stock for Shaft	1
19	S-8135	Flange Bolt 5/16"-18 x 1-1/4" ZN Grade 5	4
20	S-8322	Flange Bolt 3/8"-18 x 1-3/4" ZN Grade 5	8
21	S-9062	Flange Bolt 1/2"-13 x 1-1/4" ZN Grade 5	8
22	S-9064	Flange Bolt 3/8"-16 x 1-1/2" ZN Grade 5 Full Thread	8
23	S-9065	Flange Bolt 3/8"-16 x 1" ZN Grade 5	20
24	S-9179	Square Key 3/8" x 1-3/4"	1
25	301L0003	Decal, Rotation	1

Airlock Inlet Transition Assembly

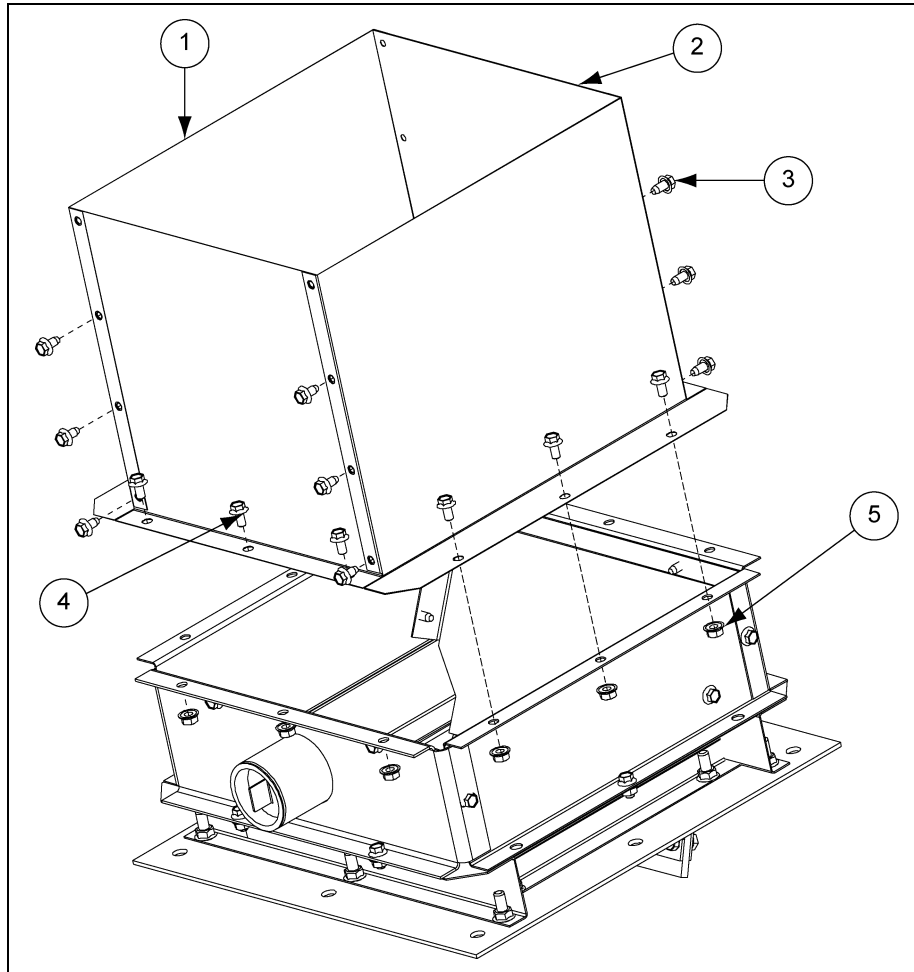

Airlock Inlet Transition Assembly Parts List

Ref #	Part #	Description	Qty
1	AS-0077	Airlock Inlet Transition - R.H. and L.H.	2
2	AS-0078	Airlock Transition - Front and Back	2
3	S-9028	Screw, SMSAB 1/4"-14 x 1/2" HWH ZN	12
4	S-8857	Flange Bolt 1/4"-20 x 1/2" ZN Grade 5	10
5	S-7215	Flange Nut 1/4"-20 ZN	10

Installation of Airlock Transition to Dryer Discharge

1. Remove the weather cover from the airlock inlet assembly.
2. Assemble two (2) AS-0077 (Ref #1) and two (2) AS-0078 (Ref #2) together with S-9028 (Ref #3) self-tapper screws as shown in [above](#) figure.
3. Determine what direction the airlock grain line is to run. Orient the transition assembly to correspond with the line direction. Attach the transition assembly to the airlock inlet using S-8857 (Ref #4) and S-7215 (Ref #5).
4. Trim the top of the transition assembly to match the height of the dryer discharge.

Inner Door Assembly

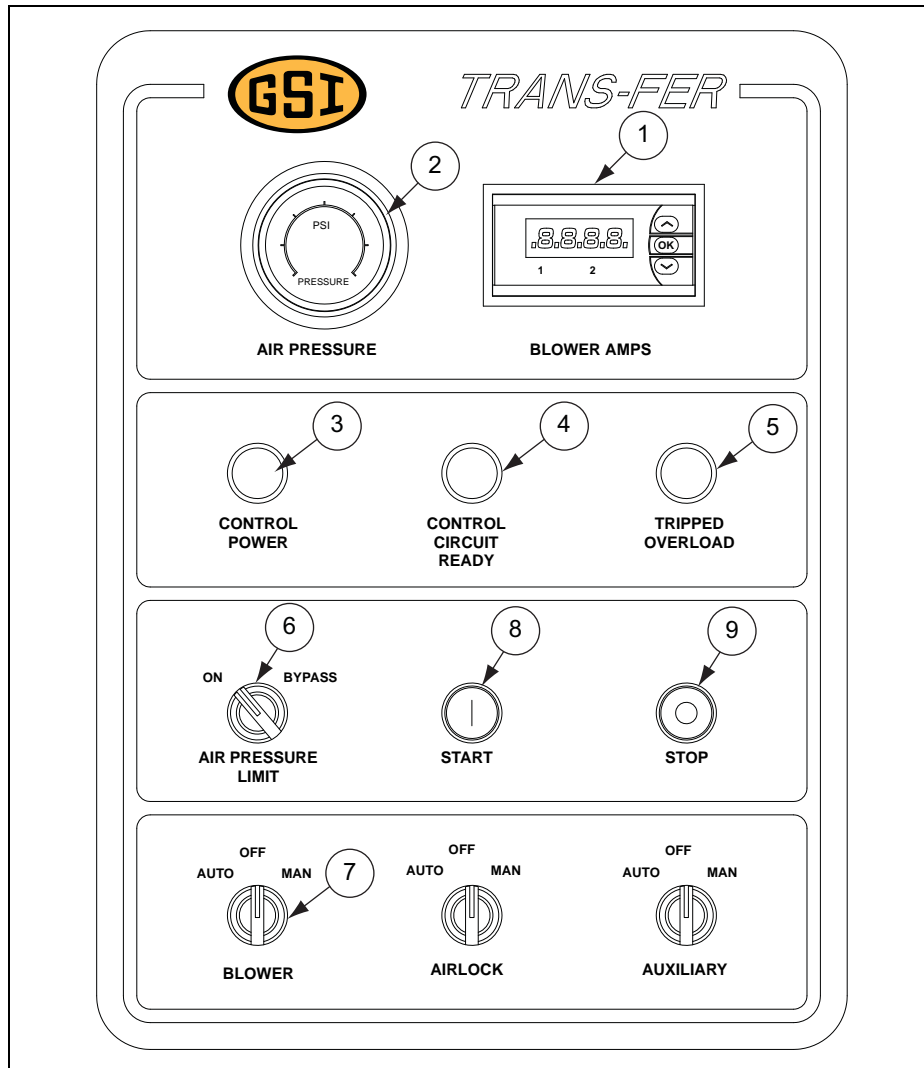

Inner Door Assembly Parts List

Ref #	Part #	Description	Qty
1	AS-0715	LED Display	1
2	AS-0720	Air Pressure Gauge	1
3	AS-0727	Yellow Pilot Light (Control Power)	1
4	AS-0725	Green Pilot Light (Control Circuit Ready)	1
5	AS-0726	Red Pilot Light (Tripped Overload)	1
6	AS-0719	2 Position Selector Switch (Air Pressure Override)	1
7	AS-0724	3 Position Selector Switch (Motor Selector Switch)	3
8	AS-0717	22 mm Push Button Operator - Green (Start)	1
9	AS-0718	22 mm Push Button Operator - Red (Stop)	1
N/S	AS-0721	40 mm Enable/Disable Stop	1
N/S	4FH1122	Hose Barb - 1/4" Hose	1
N/S	4FH0452	Street Elbow	1
N/S	AS-0763	Hose - 1/4" I.D. x 4' Long	1

12. Parts List

Control Panel Parts 230V - 3 PH

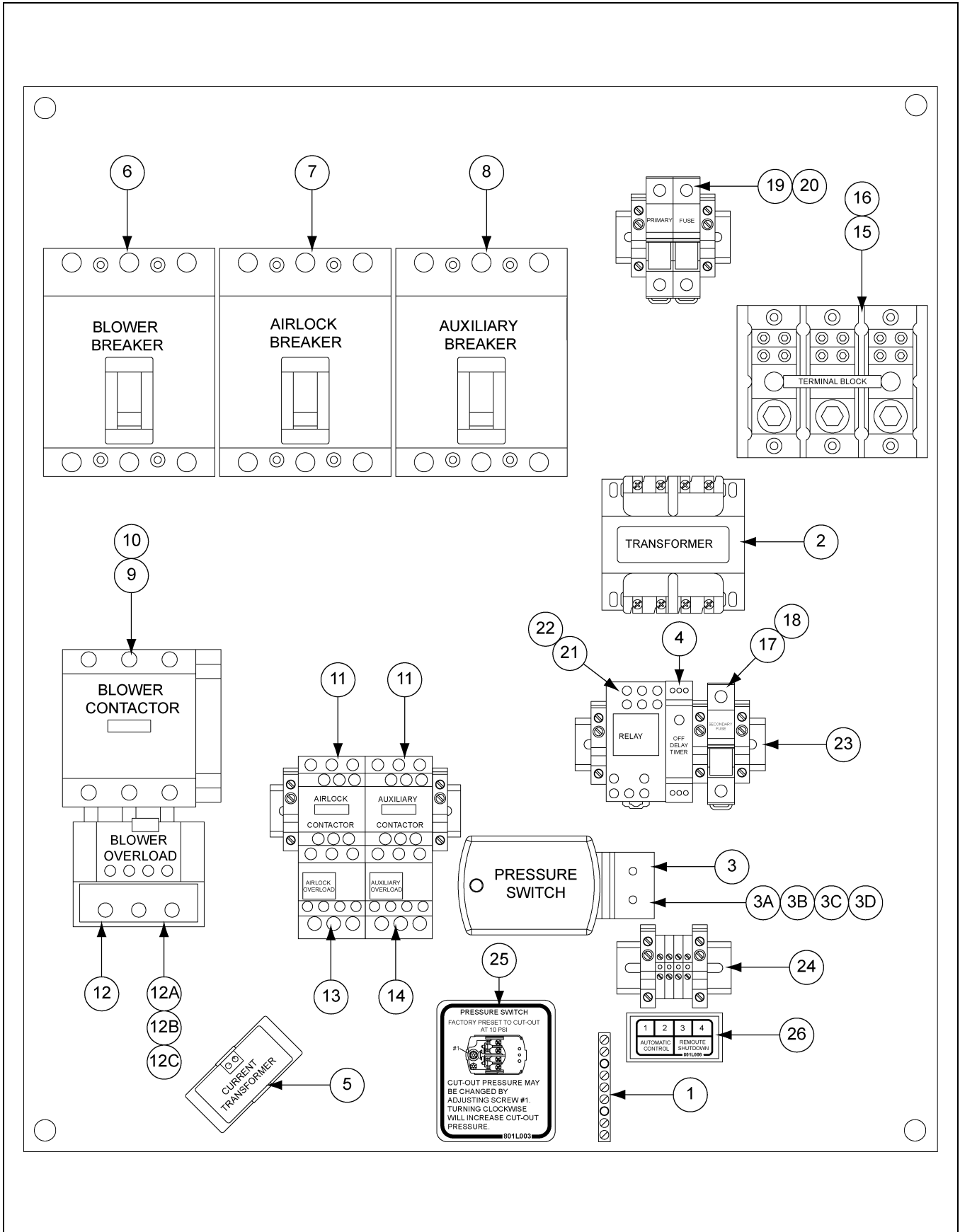

Control Panel Parts 230V - 3 PH Parts List

Ref #	Part #	Description	Qty			
			AS-0671 40 HP	AS-0672 50 HP	AS-0673 60 HP	AS-0686 75 HP
1	AS-0730	Ground Bar Kit	1	1	1	1
2	2EL0308	240/480P 120/240S Control Transformer	1	1	1	1
3	AS-0760	Switch Assembly - High Pressure (Set at 10 PSI)	1	1	1	1
3A	801E019	Switch - Pressure (Preset at 10 PSI)	1	1	1	1
3B	801E050	Bracket - Pressure Switch	1	1	1	1
3C	4FH1465	Tee, Fit - Pipe (PVC) 1/4" x 1/4" x 1/4"	1	1	1	1
3D	S-1158	Screw, TCSF #8-32 x 1/2" PHP ZN	2	2	2	2
4	AS-0716	Off/Delay Timer 250V 0.7A RE11 + Options	1	1	1	1
5	AS-0736	Current Transducer	1	1	1	1
6	D03-0897	3P 600V 150A Circuit Breaker	1			
6	D03-0950	3P 600V 200A Circuit Breaker		1		
6	GT3-1059	3P 600V 225A Circuit Breaker			1	
6	D03-0952	3P 600V 250A Circuit Breaker				1
7	D03-0929	3P 240V 20A Circuit Breaker	1	1	1	1
8	D03-0928	3P 240V 15A Circuit Breaker	1	1	1	1
9	AS-0761	115A 600V Contactor	1			
9	056-2275-8	150A 600V Contactor		1		
9	056-2054-7	185A 600V Contactor			1	
9	AS-0749	265A 600V Contactor				1
10	AS-0767	Coil 120V			1	
10	AS-0768	Coil 120V				1
11	056-1942-4	12A 110V Contactor	2	2	2	2
12	056-2276-6	90-150A Overload	1	1		
12	AS-0764	90-150A Overload			1	
12	056-2244-4	132-220A Overload				1
12A	GT3-1064	Lug Kit			1	1
12B	GT3-1063	Connector Kit			1	1
12C	GT3-1062	Overload Mount Kit			1	1
13	CH-1052	2.5-4A Overload Relay	1	1	1	1
14	CH-1053	4-6A Overload Relay	1	1	1	1
15	AS-0745	Power Distribution Block 350A 600V 3 Pole	1			
15	AS-0765	Power Distribution Block 380A 600V 3 Pole		1		
15	AS-0746	Power Distribution Block 620A 600V 3 Pole			1	1
16	AS-0744	Clear Distribution Block Cover	1			
16	AS-0747	Clear Distribution Block Cover		1	1	1
17	AS-0728	2 Amp 600V Special Purpose Fuse	1	1	1	1
18	AS-0731	Fuse Holder 600V 30 Amp 1 Pole, CC Fuse	1	1	1	1
19	AS-0729	1 Amp 600V CC TD Fuse	2	2	2	2
20	AS-0732	Fuse Holder 600V 30 Amp 2 Pole, CC Fuse	1	1	1	1
21	AS-0722	Relay	1	1	1	1
22	AS-0723	Relay - Socket	1	1	1	1
23	AS-0758	End Clamp	11	11	11	11
24	AS-0759	Terminal Block	4	4	4	4
25	801L003	Decal - Pressure Switch	1	1	1	1
26	801L006	Decal - Terminal Strip	1	1	1	1
N/S	AS-0748	Miniature Power Distribution Block 3 Pole			1	1

12. Parts List

Control Panel Parts 460V - 3 PH

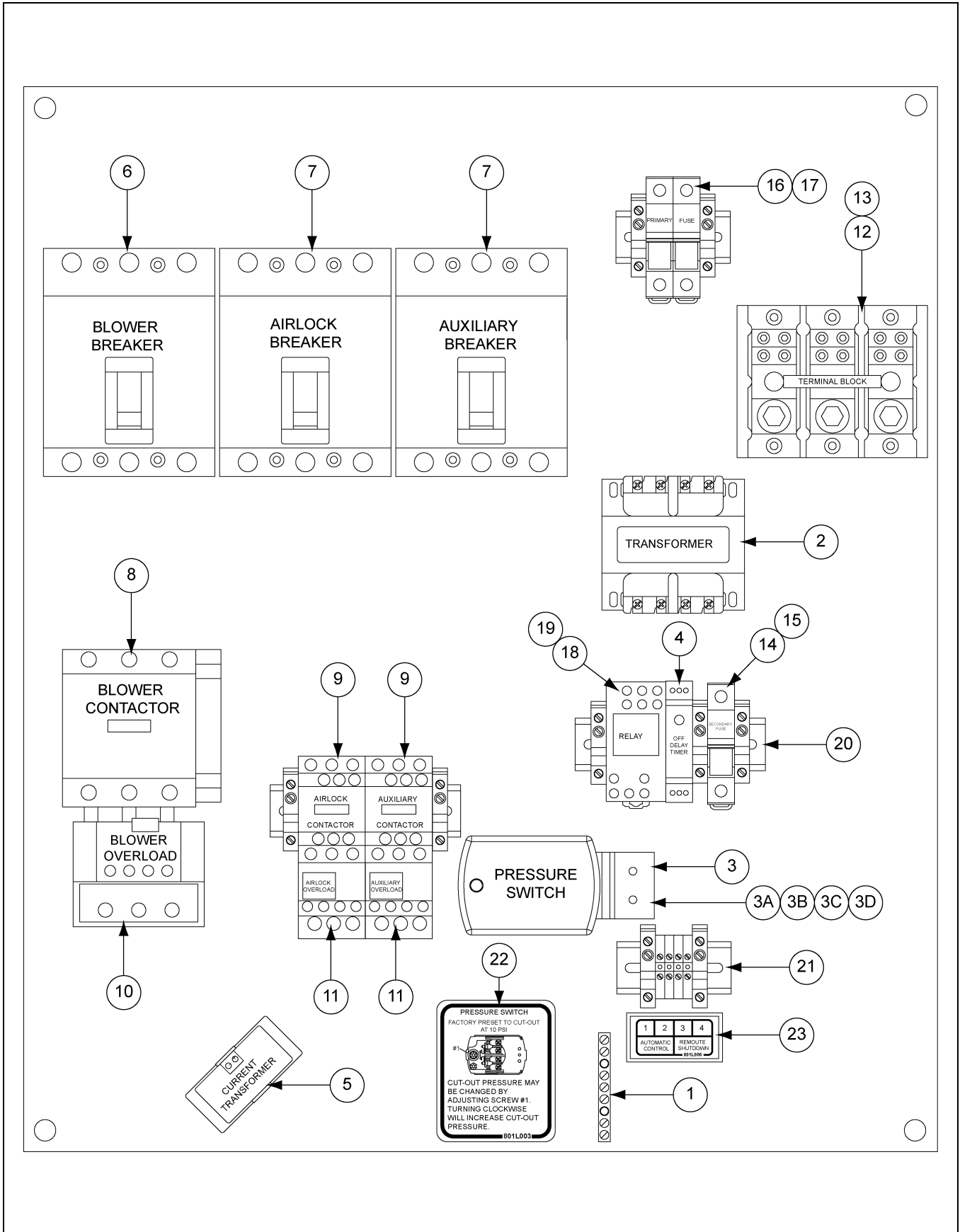

Control Panel Parts 460V - 3 PH Parts List

Ref #	Part #	Description	Qty			
			AS-0682 40 HP	AS-0683 50 HP	AS-0684 60 HP	AS-0685 75 HP
1	AS-0730	Ground Bar Kit	1	1	1	1
2	2EL0308	240/480P 120/240S Control Transformer	1	1	1	1
3	AS-0760	Switch Assembly - High Pressure (Set at 10 PSI)	1	1	1	1
3A	801E019	Switch - Pressure (Preset at 10 PSI)	1	1	1	1
3B	801E050	Bracket - Pressure Switch	1	1	1	1
3C	4FH1465	Tee, Fit - Pipe (PVC) 1/4" x 1/4" x 1/4"	1	1	1	1
3D	S-1158	Screw, TCSF #8-32 x 1/2" PHP ZN	2	2	2	2
4	AS-0716	Off/Delay Timer 250V 0.7A RE11 + Options	1	1	1	1
5	AS-0736	Current Transducer	1	1	1	1
6	026-1040-0	3P 480V 90A Circuit Breaker	1			
6	026-1062-4	3P 480V 100A Circuit Breaker		1		
6	AS-0753	3P 600V 110A Circuit Breaker			1	
6	D03-0896	3P 600V 125A Circuit Breaker				1
7	AS-0750	3P 480V 15A Circuit Breaker	2	2	2	2
8	056-1994-5A	65A 110V Contactor	1			
8	056-2030-7	80A 110V Contactor		1	1	
8	AS-0761	115A 600V Contactor				1
9	056-1942-4	12A 110V Contactor	2	2	2	2
10	D03-0984	48-65A Overload	1			
10	CH-1060	48-65A Overload		1		
10	CH-1062	63-80A Overload			1	
10	AS-0773	60-100A Overload				1
11	056-1945-7	1.6-2.5A Overload Relay	2	2	2	2
12	1EL0911	Power Distribution Block 175A 600V 3 Pole	1	1		
12	AS-0743	Power Distribution Block 335A 600V 3 Pole			1	
12	AS-0745	Power Distribution Block 350A 600V 3 Pole				1
13	AS-0742	Clear Distribution Block Cover	1	1		
13	AS-0744	Clear Distribution Block Cover			1	1
14	AS-0728	2 Amp 600V Special Purpose Fuse	1	1	1	1
15	AS-0731	Fuse Holder 600V 30 Amp 1 Pole, CC Fuse	1	1	1	1
16	AS-0770	6/10 Amp 600V CC TD Fuse	2	2	2	2
17	AS-0732	Fuse Holder 600V 30 Amp 2 Pole, CC Fuse	1	1	1	1
18	AS-0722	Relay	1	1	1	1
19	AS-0723	Relay - Socket	1	1	1	1
20	AS-0758	End Clamp	11	11	11	11
21	AS-0759	Terminal Block	4	4	4	4
22	801L003	Decal - Pressure Switch	1	1	1	1
23	801L006	Decal - Terminal Strip	1	1	1	1

12. Parts List

Control Panel Parts 575V - 3 PH

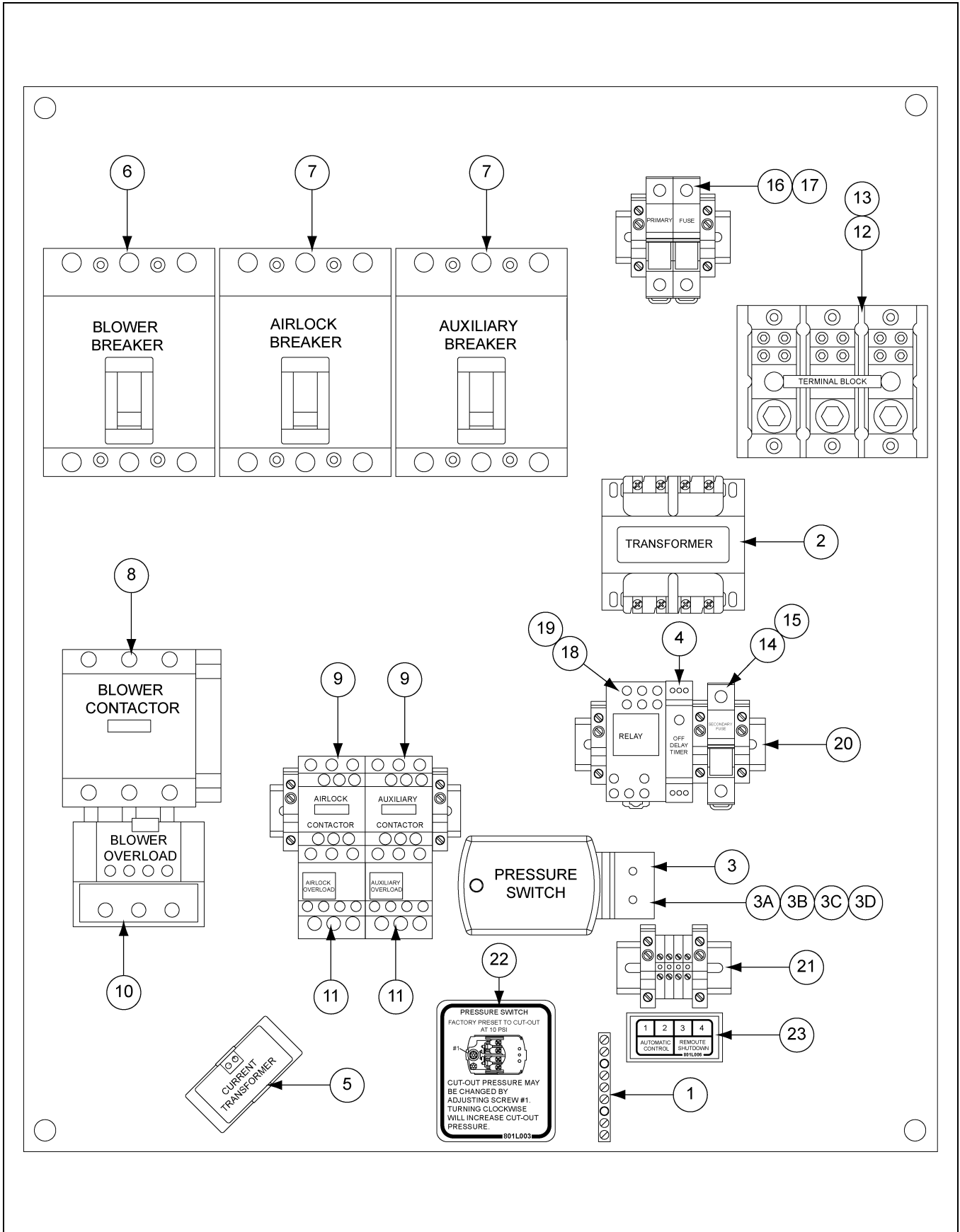

Control Panel Parts 575V - 3 PH Parts List

Ref #	Part #	Description	Qty			
			AS-0708 40 HP	AS-0709 50 HP	AS-0710 60 HP	AS-0711 75 HP
1	AS-0730	Ground Bar Kit	1	1	1	1
2	AS-0774	600V - 120/240V Control Transformer	1	1	1	1
3	AS-0760	Switch Assembly - High Pressure (Set at 10 PSI)	1	1	1	1
3A	801E019	Switch - Pressure (Preset at 10 PSI)	1	1	1	1
3B	801E050	Bracket- Pressure Switch	1	1	1	1
3C	4FH1465	Tee, Fit - Pipe (PVC) 1/4" x 1/4" x 1/4"	1	1	1	1
3D	S-1158	Screw, TCSF #8-32 x 1/2" PHP ZN	2	2	2	2
4	AS-0716	Off/Delay Timer 250V 0.7A RE11 + Options	1	1	1	1
5	AS-0736	Current Transducer	1	1	1	1
6	AS-0783	3P 600V 80A Circuit Breaker	1			
6	AS-0785	3P 600V 90A Circuit Breaker		1		
6	056-1422-7	3P 600V 100A Circuit Breaker			1	
6	AS-0788	3P 600V 110A Circuit Breaker				1
7	AS-0775	3P 600V 15A Circuit Breaker	2	2	2	2
8	AS-0784	50A 110V Contactor	1			
8	056-1994-5A	65A 110V Contactor		1		
8	056-2030-7	80A 110V Contactor			1	1
9	056-1942-4	12A 110V Contactor	2	2	2	2
10	AS-0752	37-50A Overload	1	1		
10	CH-1060	48-65A Overload			1	
10	AS-0773	60-100A Overload				1
11	056-1945-7	1.6-2.5A Overload Relay	2	2	2	2
12	1EL0911	Power Distribution Block 175A 600V 3 Pole	1	1	1	1
13	AS-0742	Clear Distribution Block Cover	1	1	1	1
14	AS-0728	2 Amp 600V Special Purpose Fuse	1	1	1	1
15	AS-0731	Fuse Holder 600V 30 Amp 1 Pole, CC Fuse	1	1	1	1
16	AS-0770	6/10 Amp 600V CC TD Fuse	2	2	2	2
17	AS-0732	Fuse Holder 600V 30 Amp 2 Pole, CC Fuse	1	1	1	1
18	AS-0722	Relay	1	1	1	1
19	AS-0723	Relay - Socket	1	1	1	1
20	AS-0758	End Clamp	11	11	11	11
21	AS-0759	Terminal Block	4	4	4	4
22	801L003	Decal - Pressure Switch	1	1	1	1
23	801L006	Decal - Terminal Strip	1	1	1	1

13. Troubleshooting

Problem	Solution
System plugs up.	<ol style="list-style-type: none"> 1. Check belt tension on air blower and tighten if loose. 2. Check air filter and clean out. Locate in a place where there is less dust. 3. Check tubing system for any obstructions. 4. Reduce feed-in rate. 5. Air Pressure switch setting may be too low. 6. Outlet gate valve too far open.
Excessive grain damage.	<ol style="list-style-type: none"> 1. May be overfeeding airlock, causing vanes to shear off grain. Reduce feed rate. 2. Air velocity may be excessive. Slow air blower by changing pulleys or by opening gate valve. 3. Damage can occur if system is running at less than full capacity. Increase feed rate. 4. Rubber hose used to change grain direction or used for extended lengths. 5. Airlock shear protector installed wrong.
Airlock stops or is noisy.	<ol style="list-style-type: none"> 1. A foreign object may have become lodged in the airlock vanes. 2. Check chain tension. 3. Check gearbox drive. 4. The rotor vanes may be rubbing on the ends of the airlock. Check clearance at both ends of rotor and center in housing by loosening the set screws in the bearings on both ends of the rotor shaft and moving rotor. Tighten set screws after re-positioning. 5. The rotor vanes may have become rusted to the airlock housing. The airlock can be broken loose by using a pipe wrench on the exposed rotor shaft. <div data-bbox="570 1020 1458 1131" style="border: 1px solid black; padding: 5px; margin: 10px 0;">  <p>The worm drive gearbox <u>cannot</u> be driven in reverse and can be damaged. Remove the airlock drive chain before attempting to turn the airlock by hand.</p> </div> <ol style="list-style-type: none"> 6. "U" cup packings on rotor too tight. (Contact factory.)
Unit does not start, "ready light" is not ON.	<ol style="list-style-type: none"> 1. Check AC power supply. 2. Check control box fuses. 3. Thermal overload tripped (overload indicator is ON). 4. Air Pressure Limit switch may be misadjusted (less than 5 PSI). If pressure switch is not reset, turn pressure adjustment clockwise until switch resets. 5. Be sure "Start" switch is pushed.
Unit does not start, the "ready light" is ON.	<ol style="list-style-type: none"> 1. Blower, Airlock and Auxiliary switches must be in either "AUTO" or "MANUAL" to operate. 2. The automatic control not wired correctly or not working. (Requires a closed contact across TB1 and TB2 to auto start.)
Blower motor trips thermal overload.	<ol style="list-style-type: none"> 1. Check current draw using amp meter. The motor should not be pulling more current than the nameplate specifies. Reduce feed rate if excessive. 2. Check overload amp settings. 3. Check for loose connections and/or too small gauge wire. 4. Wrong voltage (either high or low). 5. Too much load due to obstructions, bad bearings or dry gears.
No control voltage.	<ol style="list-style-type: none"> 1. Control fuse inside the control box is down. 2. Check main power for proper voltage. 3. Check transformer fuses.

How to Handle Handling Couplings

Couplings are shipped ready-to-install. Do not disassemble. To prevent gasket from slipping out of proper position, always grasp coupling as shown in [Figure 14A](#). This will save time by maintaining proper position of gasket and sleeve in relation to shell and flange.

Installing Couplings

1. Confirm pipe O.D. size you intend joining. Each compression coupling has been factory inspected for proper O.D. size before shipment.
2. Be sure outside surface of pipe is dry and free of dirt, grease or external burrs. (Burrs and jagged pipe ends can cut gasket; dirt and grease can cause coupling slippage.)
3. Grasp coupling as shown in [Figure 14A](#) to keep gasket and sleeve (and gasket protector when used) in separate quadrants, as shown in [Figure 14A](#). Be sure gasket teeth mesh and do not overlap.
4. Slide coupling over one pipe past end, then butt pipe ends. (A small gap 1/16 maximum at butt joint will not reduce coupling performance.) Slide coupling back until coupling and gasket protector are centered over joint. Use care when sliding coupling into place. Avoid wrinkling of gasket or gasket protector.
5. The gasket protector provides a bleed path for static electricity.
6. Partially tighten bolts evenly as follows:
 - 1/2" Bolt size - 45 ft. lbs. torque
 - 5/8" Bolt size - 65 ft. lbs. torque
 - 3/4" Bolt size - 95 ft. lbs. torque

(Where SAE grade 5 5/8" bolts are specified tighten to 95 ft. lbs. For couplings with aluminum shell and inner sleeve do not exceed 40 ft. lbs.)
7. When properly and evenly tightened to the recommended torque the coupling installation is complete. The top edges of the flanges will touch and flanges appear as a vee when viewed from the end, as shown in [Figure 14A](#). **DO NOT** attempt tightening bolts to flatten flange faces together, as this exceeds recommended limits.

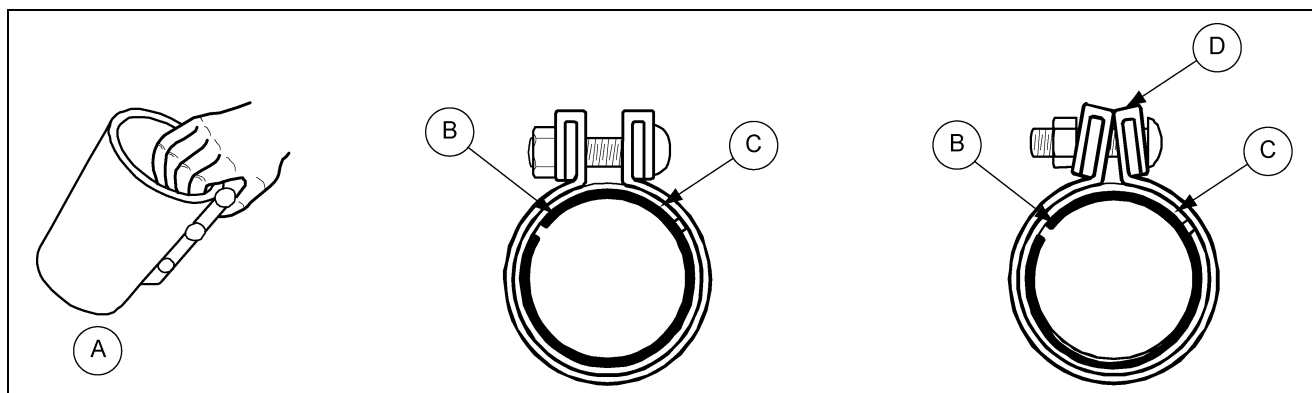

Figure 14A

Ref #	Description	Ref #	Description
A	Grasp as shown	C	Sleeve Location
B	Gasket Location	D	Top of Flange

NOTES

GSI Group, LLC Limited Warranty

The GSI Group, LLC ("GSI") warrants products which it manufactures to be free of defects in materials and workmanship under normal usage and conditions for a period of 12 months after sale to the original end-user or if a foreign sale, 14 months from arrival at port of discharge, whichever is earlier. The end-user's sole remedy (and GSI's only obligation) is to repair or replace, at GSI's option and expense, products that in GSI's judgment, contain a material defect in materials or workmanship. Expenses incurred by or on behalf of the end-user without prior written authorization from the GSI Warranty Group shall be the sole responsibility of the end-user.

Warranty Extensions:

The Limited Warranty period is extended for the following products:

	Product	Warranty Period	
AP Fans and Flooring	Performer Series Direct Drive Fan Motor	3 Years	* Warranty prorated from list price: 0 to 3 years - no cost to end-user 3 to 5 years - end-user pays 25% 5 to 7 years - end-user pays 50% 7 to 10 years - end-user pays 75% ** Warranty prorated from list price: 0 to 3 years - no cost to end-user 3 to 5 years - end-user pays 50%
	All Fiberglass Housings	Lifetime	
	All Fiberglass Propellers	Lifetime	
AP and Cumberland	Flex-Flo/Pan Feeding System Motors	2 Years	
Cumberland Feeding/Watering Systems	Feeder System Pan Assemblies	5 Years **	
	Feed Tubes (1-3/4" and 2.00")	10 Years *	
	Centerless Augers	10 Years *	
	Watering Nipples	10 Years *	
Grain Systems	Grain Bin Structural Design	5 Years	† Motors, burner components and moving parts not included. Portable dryer screens included. Tower dryer screens not included.
Grain Systems Farm Fans Zimmerman	Portable and Tower Dryers	2 Years	
	Portable and Tower Dryer Frames and Internal Infrastructure †	5 Years	

GSI further warrants that the portable and tower dryer frame and basket, excluding all auger and auger drive components, shall be free from defects in materials for a period of time beginning on the twelfth (12th) month from the date of purchase and continuing until the sixtieth (60th) month from the date of purchase (extended warranty period). During the extended warranty period, GSI will replace the frame or basket components that prove to be defective under normal conditions of use without charge, excluding the labor, transportation, and/or shipping costs incurred in the performance of this extended warranty.

Conditions and Limitations:

THERE ARE NO WARRANTIES THAT EXTEND BEYOND THE LIMITED WARRANTY DESCRIPTION SET FORTH ABOVE. SPECIFICALLY, GSI MAKES NO FURTHER WARRANTY OF ANY KIND, EXPRESS OR IMPLIED, INCLUDING, WITHOUT LIMITATION, WARRANTIES OF MERCHANTABILITY OR FITNESS FOR A PARTICULAR PURPOSE OR USE IN CONNECTION WITH: (I) PRODUCT MANUFACTURED OR SOLD BY GSI OR (II) ANY ADVICE, INSTRUCTION, RECOMMENDATION OR SUGGESTION PROVIDED BY AN AGENT, REPRESENTATIVE OR EMPLOYEE OF GSI REGARDING OR RELATED TO THE CONFIGURATION, INSTALLATION, LAYOUT, SUITABILITY FOR A PARTICULAR PURPOSE, OR DESIGN OF SUCH PRODUCTS.

GSI shall not be liable for any direct, indirect, incidental or consequential damages, including, without limitation, loss of anticipated profits or benefits. The sole and exclusive remedy is set forth in the Limited Warranty, which shall not exceed the amount paid for the product purchased. This warranty is not transferable and applies only to the original end-user. GSI shall have no obligation or responsibility for any representations or warranties made by or on behalf of any dealer, agent or distributor.

GSI assumes no responsibility for claims resulting from construction defects or unauthorized modifications to products which it manufactured. Modifications to products not specifically delineated in the manual accompanying the equipment at initial sale will void the Limited Warranty.

This Limited Warranty shall not extend to products or parts which have been damaged by negligent use, misuse, alteration, accident or which have been improperly/inadequately maintained. This Limited Warranty extends solely to products manufactured by GSI.

Prior to installation, the end-user has the responsibility to comply with federal, state and local codes which apply to the location and installation of products manufactured or sold by GSI.

This equipment shall be installed in accordance with the current installation codes and applicable regulations, which should be carefully followed in all cases. Authorities having jurisdiction should be consulted before installations are made.



**1004 E. Illinois St.
Assumption, IL 62510-0020
Phone: 1-217-226-4421
Fax: 1-217-226-4420
www.gsiag.com**



GSI is a worldwide brand of AGCO Corporation.