



Series 2 12"-14" Tall En-Masse Chain Conveyors

Installation and Operation Manual

PNEG-763

Date: 01-04-13

GSI GROUP



PNEG-763

Equipment Information

Use of the Equipment Information page will help you identify your equipment in case you need to call your dealer or installer. This information should be filled out and kept on record.

Equipment Information

Model Number: _____

Date Purchased: _____

Serial Number: _____

Dealer/Distributor Name and Phone Number:

All information, illustrations, photos, and specifications in this manual are based on the latest information available at the time of publication. The right is reserved to make changes at any time without notice.

Contents

Chapter 1 Introduction	4
Chapter 2 Safety	5
Safety Guidelines	5
Safety Instructions	6
Operator Qualifications	9
Chapter 3 Safety Decals	10
Head Section Decal Locations	10
Tail Section Decal Locations	11
Chapter 4 General Precautions	12
Chapter 5 Inspection	13
Receiving Inspection	13
Pre-Installation Preparation	13
Chapter 6 Installation	14
Head and Tail Assembly	14
Intermediate Trough Section Assembly	14
Cover Assembly Installation	17
Inlet Assembly and Installation	18
Drag Chain Assembly Installation	18
Motor and Torque Arm II Reducer Installation	20
Chapter 7 Care and Maintenance	26
Welding	26
Motor	26
Support	26
Discharge	26
Chapter 8 Storage	27
Chapter 9 Motion Sensor Option	28
Installation Instructions (Whirligig - WG1-4B)	28
Chapter 10 Options	29
Inspection Ports	29
Plug Relief Door w/o Head Gate	30
Plug Relief Switch w/ Head Gate	31
Slack Chain - Roller Returns	31
Slack Chain - Slide Rail Returns	34
Bypass Inlet with Baffles	35
Head Discharge with Take-Up	36
Carry-Over Bars	36
Chapter 11 Troubleshooting	37
Chapter 12 Warranty	39

1. Introduction

READ THIS MANUAL carefully to learn how to properly use and install equipment. Failure to do so could result in personal injury or equipment damage.

INSPECT the shipment immediately upon arrival. The customer is responsible for ensuring that all quantities are correct. The customer should report and note any damage or shortage on the bill of lading to justify their claim to the transport company.

THIS MANUAL SHOULD BE CONSIDERED a permanent part of your equipment and should be easily accessible when needed.

This warranty provides you the assurance that the company will back its products when defects appear within the warranty period. In some circumstances, the company also provides field improvements, often without charge to the customer, even if the product is out of warranty. Should the equipment be abused, or modified to change its performance beyond the factory specifications, the warranty will become void and field improvements may be denied.

Safety Guidelines

This manual contains information that is important for you, the owner/operator, to know and understand. This information relates to protecting **personal safety** and **preventing equipment problems**. It is the responsibility of the owner/operator to inform anyone operating or working in the area of this equipment of these safety guidelines. To help you recognize this information, we use the symbols that are defined below. Please read the manual and pay attention to these sections. Failure to read this manual and its safety instructions is a misuse of the equipment and may lead to serious injury or death.



This is the safety alert symbol. It is used to alert you to potential personal injury hazards. Obey all safety messages that follow this symbol to avoid possible injury or death.



DANGER indicates an imminently hazardous situation which, if not avoided, will result in death or serious injury.



WARNING indicates a potentially hazardous situation which, if not avoided, could result in death or serious injury.



CAUTION indicates a potentially hazardous situation which, if not avoided, may result in minor or moderate injury.



CAUTION used without the safety alert symbol indicates a potentially hazardous situation which, if not avoided, may result in property damage.



NOTE indicates information about the equipment that you should pay special attention.

Safety Instructions

Our foremost concern is your safety and the safety of others associated with this equipment. We want to keep you as a customer. This manual is to help you understand safe operating procedures and some problems which may be encountered by the operator and other personnel.

As owner and/or operator, it is your responsibility to know what requirements, hazards and precautions exist, and to inform all personnel associated with the equipment or in the area. Safety precautions may be required from the personnel. Avoid any alterations to the equipment. Such alterations may produce a very dangerous situation where SERIOUS INJURY or DEATH may occur.

This equipment shall be installed in accordance with the current installation codes and applicable regulations which should be carefully followed in all cases. Authorities having jurisdiction should be consulted before installations are made.

Follow Safety Instructions

Carefully read all safety messages in this manual and safety signs on your machine. Keep signs in good condition. Replace missing or damaged safety signs. Be sure new equipment components and repair parts include the current safety signs. Replacement safety signs are available from the manufacturer.

Learn how to operate the machine and how to use controls properly. Do not let anyone operate without instruction.

Keep your machinery in proper working condition. Unauthorized modifications to the machine may impair the function and/or safety and affect machine life.

If you do not understand any part of this manual or need assistance, contact your dealer.

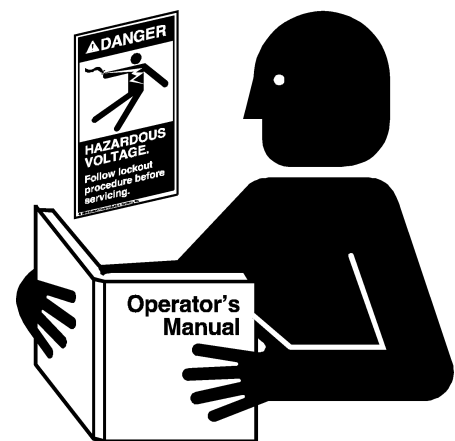

Read and Understand Manual

Practice Safe Maintenance

Understand service procedures before doing work. Keep area clean and dry.

Never lubricate, service, or adjust machine while it is in operation. Keep hands, feet and clothing away from rotating parts.

Keep all parts in good condition and properly installed. Fix damage immediately. Replace worn or broken parts. Remove any built up grease oil and debris.



Maintain Equipment and Work Area

Remove Paint Before Welding or Heating

Avoid potentially toxic fumes and dust.

Hazardous fumes can be generated when paint is heated by welding, soldering, or using a torch.

Do all work outside or in a well-ventilated area.

Dispose of paint and solvent properly.

Remove paint before welding or heating:

- If you sand or grind paint, avoid breathing the dust. Wear an approved respirator.
- If you use solvent or paint stripper, remove stripper with soap and water before welding. Remove solvent or stripper containers and other flammable material from area. Allow fumes to disperse at least 15 minutes before welding or heating.



Breathing Hazard

Operate Motor Properly

In an emergency, shut down the power source.

Turn OFF and lock out all power sources before performing any maintenance.

Do not operate electric motor equipped units until motors are properly grounded.

Disconnect power on electrical driven units before resetting motor overloads.

Do not repetitively stop and start the drive in order to free a plugged condition. Jogging the drive in this manner can damage the equipment and/or drive components.



Electric Shock Hazard

Prepare for Emergencies

Be prepared if fire starts.

Keep a first aid kit and fire extinguisher handy.

Keep emergency numbers for doctors, ambulance service, hospital and fire department near your telephone.

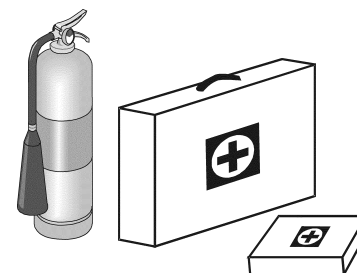

Keep Emergency Equipment Quickly Accessible

2. Safety

Wear Protective Clothing

Wear close fitting clothing and safety equipment appropriate to the job.

Remove all jewelry.

Long hair should be tied up and back.

Safety glasses should be worn at all times to protect eyes from debris.

Wear gloves to protect your hands from sharp edges on plastic or steel parts.

Wear steel toe boots to help protect your feet from falling debris. Tuck in any loose or dangling shoe strings.

A respirator may be needed to prevent breathing potentially toxic fumes and dust.

Wear hard hat to help protect your head.

Wear appropriate fall protection equipment when working at elevations greater than six feet (6').

Eye Protection

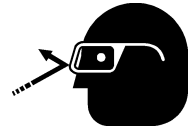

Gloves



Steel Toe Boots



Respirator



Hard Hat



Fall Protection



Operator Qualifications

- A. The User/Operator must be competent and experienced to operate auger equipment. Anyone who works with or around augers must have good common sense in order to be qualified. These persons must also know and meet all other qualifications, such as:
- i. Any person who has not read and/or does not understand all operation and safety procedures is not qualified to operate any auger systems.
 - ii. Certain regulations apply to personnel operating power machinery. Personnel under the age of 18 years may not operate power machinery, including augers. It is your responsibility, as owner and/or supervisor, to know what these regulations are in your area or situation.
 - iii. Unqualified or incompetent persons are to remain out of the work area.
 - iv. O.S.H.A. (Occupational Safety and Health Administration) regulations state: "At the time of initial assignment and at least annually thereafter, the employer shall instruct every employee in the safe operation and servicing of all equipment with which the employee is, or will be involved". (Federal Occupational Safety and Health Standards for Agriculture. Subpart D, Section 19287.57 (a) (6)).
- B. As a requirement of O.S.H.A., it is necessary for the employer to train the employee in the safe operating and safety procedures for this auger. The sign-off sheet is provided for your convenience and personal record keeping. All unqualified persons are to stay out of the work area at all times. It is strongly recommended that another qualified person who knows the shut down procedure is in the area in the event of an emergency.

<i>Date</i>	<i>Employee Name</i>	<i>Supervisor Name</i>

Head Section Decal Locations

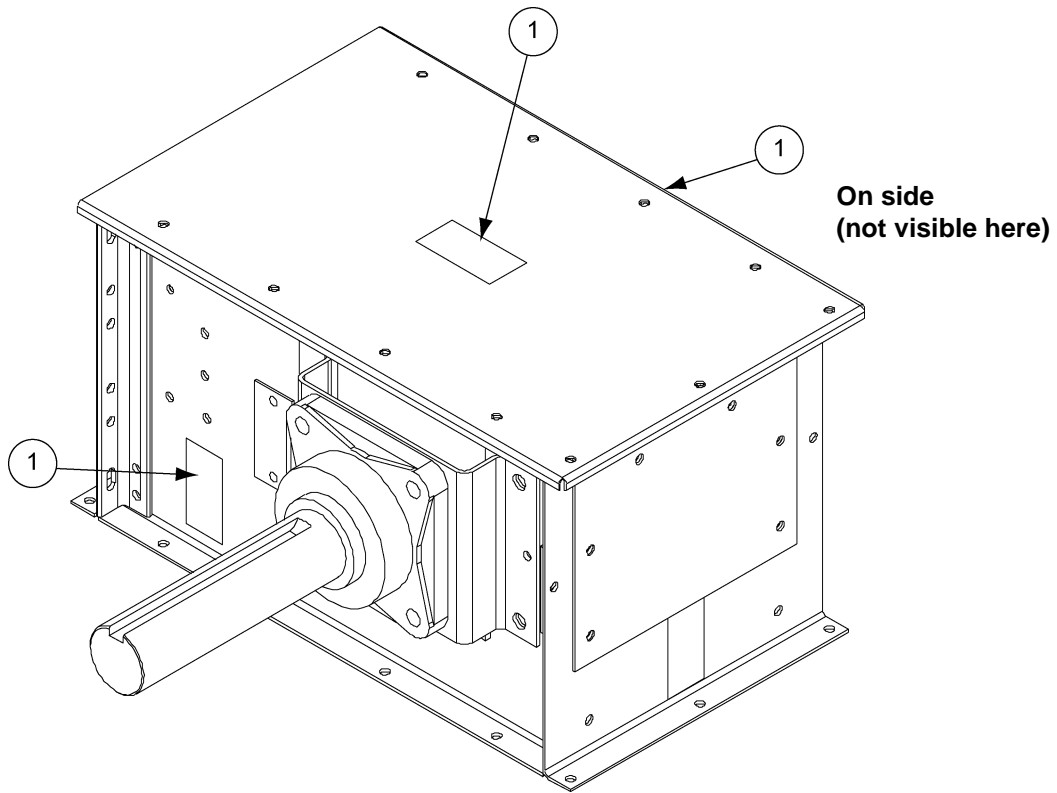

⚠ WARNING!

Moving parts can crush and cut. Keep hands clear. Do not operate without guards in place. Failure to do so could result in serious injury.

DC-972

Tail Section Decal Locations

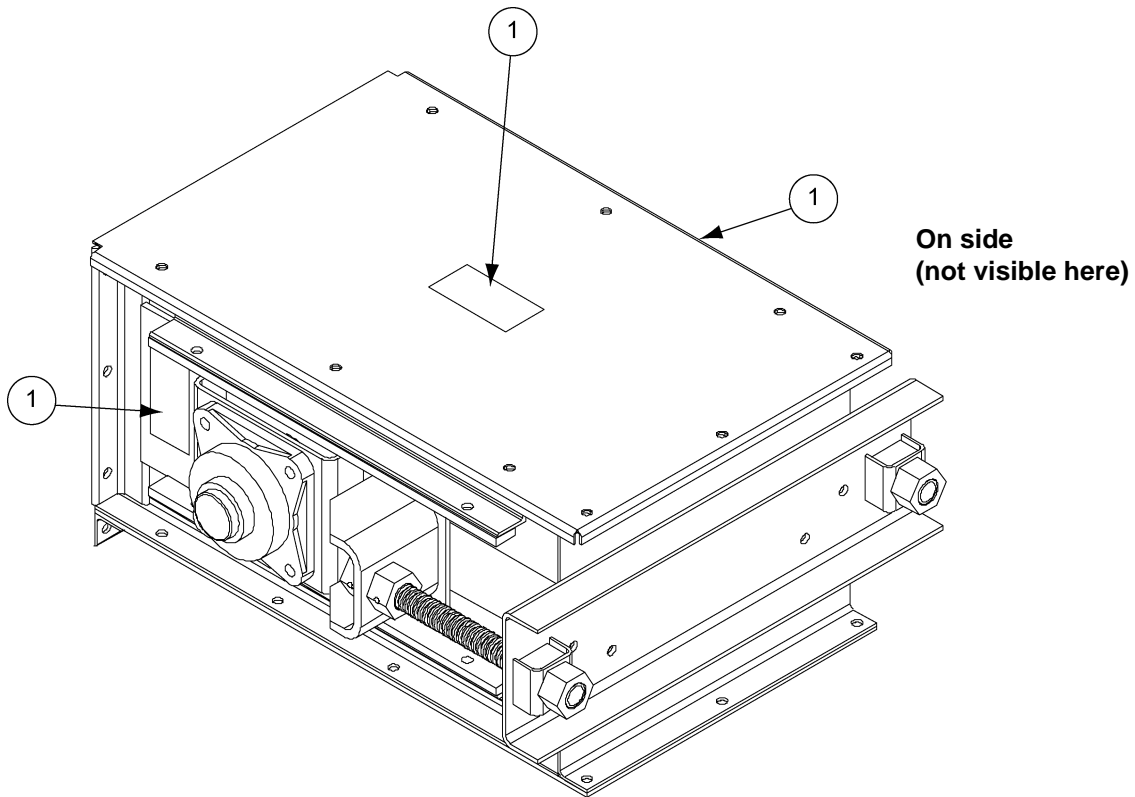

⚠ WARNING!

Moving parts can crush and cut. Keep hands clear. Do not operate without guards in place. Failure to do so could result in serious injury.

DC-972

1

4. General Precautions



- 1. Read and understand the Operator's Manual BEFORE operating the unit.**
- 2. Keep all safety shields and devices in place.**
- 3. Keep all covers in place.**
- 4. Make certain everyone is clear of the equipment before operating.**
- 5. Keep hands, feet and clothing away from moving parts.**
- 6. Shut OFF and lock out all power to adjust, service, clean or unclog the unit.**
- 7. Keep off the equipment at all times.**
- 8. Keep children, visitors and all untrained personnel away from the machine when in operation.**
- 9. Do not operate electric motor equipped units until motors are properly grounded.**
- 10. Disconnect power on electrical driven units before resetting motor overloads.**
- 11. Do not repetitively stop and start the drive in order to free a plugged condition. "Jogging" the drive in this manner can damage the conveyor and/or drive components.**

Receiving Inspection

Carefully inspect the shipment as soon as it is received. Verify that the quantity of parts or packages actually received corresponds to the quantity shown on the packing slip. Any discrepancies should be clarified immediately. Please remember that any damage or missing parts must be noted on the bill of lading at the time of delivery. Report any damage or shortage to the delivering carrier as soon as possible. GSI's responsibility for damage to the equipment ends with acceptance by the delivering carrier.

Save all paperwork and documentation furnished with any of the chain conveyor components.

Pre-Installation Preparation

Familiarize yourself thoroughly with this manual and all the conveyor parts. Read the Operator's Manual and all safety signs before using or servicing equipment. Taking the time to do so will aid in the assembly of the conveyor.

Remove all banding and crating material. Arrange the conveyor components so that they are easily accessible.

Locate sturdy items to serve as blocking (i.e. wood blocks, saw horses, etc.). Blocking is used to support the conveyor sections above the ground to aid in assembly. Locate and place the conveyor sections on the blocking in order, starting with the head section and concluding with the tail section.

Head and Tail Assembly

The head and tail sections of the chain conveyor are shipped pre-assembled direct from the factory. Intermediate trough sections may come factory pre-assembled or unassembled. The order will serve as a reference to how the trough section will arrive. If you have any questions, please refer to the order confirmation.

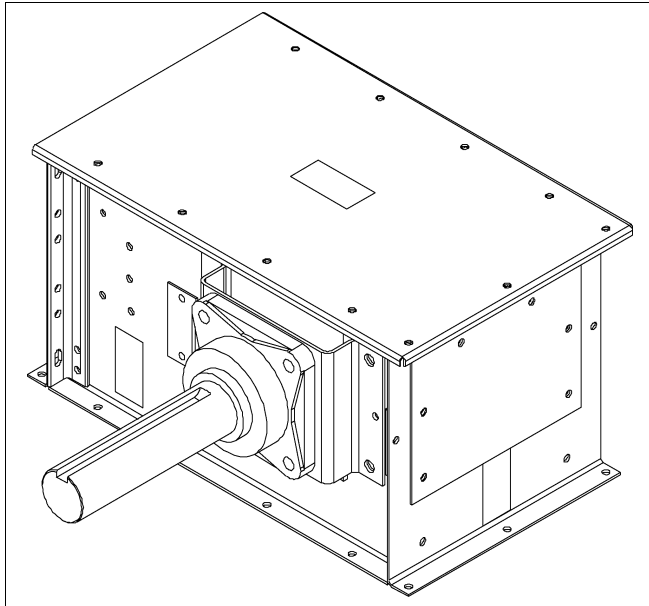

Figure 6A Head Assembly

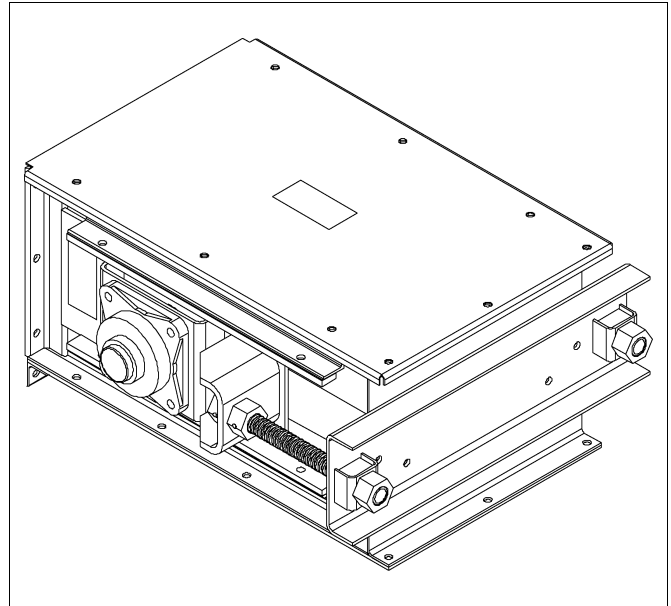

Figure 6B Tail Assembly

Intermediate Trough Section Assembly

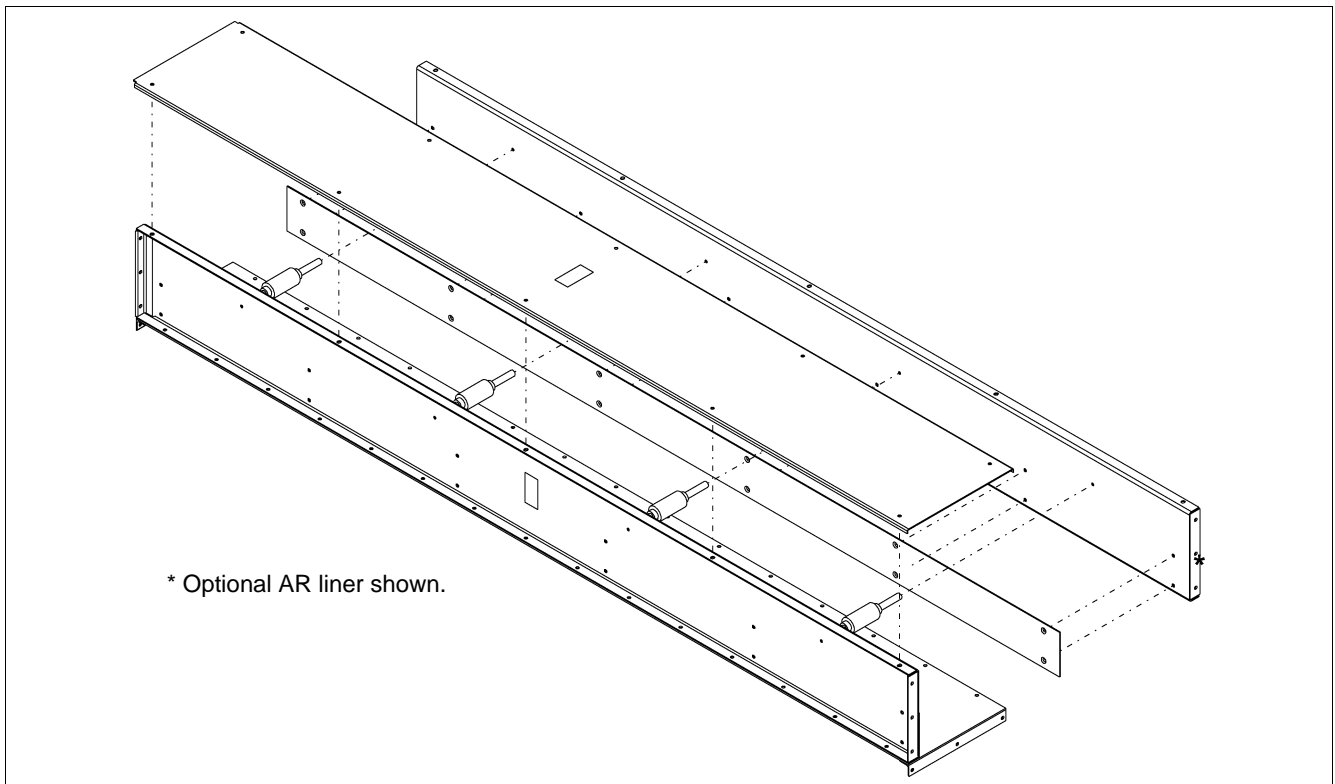

Figure 6C Typical Intermediate Trough Section Assembly with Roller Returns

An en-masse conveyor may be purchased with unassembled trough sections. The following recommendations may prove useful in the assembly.

Before assembling conveyor trough sections together, remove the covers. Covers should be stored in a protected area in order to minimize any possible damage. Remember to retain factory shipped hardware for conveyor cover installation.

Take a moment to familiarize yourself with the trough assembly. If the conveyor is equipped with UHMW roller returns, check that the rollers turn freely. If the conveyor is equipped with slide rail returns, the wide end of the rail returns face *away from* the discharge end of the conveyor, except in the 14 x 20 size.

(See Figure 6E on Page 16.)

Intermediate trough sections are supplied in standard ten feet (10') lengths. Depending on the application and individual specifications however, shorter sections may be required to accommodate a given overall length.

Lay bottom plate weldment onto blocking material. Next, loosely attach side weldments to bottom plate with 3/8" hardware provided. Then fasten UHMW roller returns or slide rail return weldment to intermediate sides with the 5/16" whiz flange cap screws.

NOTE: When installing UHMW roller returns, check that they are centered within the box. It is important that the inside dimensions of the box are equidistant from the bottom plate to the roller/slide rail shafts. (See Figure 6D.)

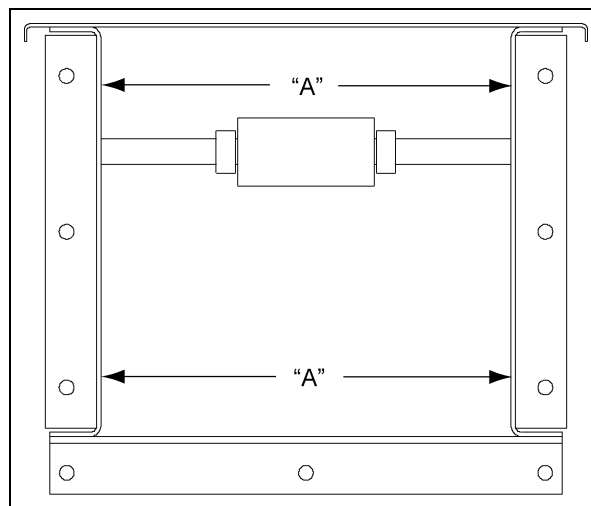

Figure 6D

It is critical for straightness of conveyor that the sides and bottom flanges are aligned flush.

After making sure the flanges are aligned, tighten all hardware on the trough section. When any optional Abrasion Resistant (A.R.) liners are ordered, they may be installed with the 3/8" flat countersunk hardware provided. Adequately tighten liners to conveyor sides. Check that the countersunk hardware is not protruding above the surface of the A.R. liners.

During assembly of each trough section to the next section, carefully inspect each flange joint to ensure that the inside bottom and side surfaces of the trough are flush. A chalk line is helpful during this phase of the assembly to ensure the proper alignment of the trough surfaces. The maximum run-out in any direction should be $\pm 1/4$ ". Proper alignment minimizes wear on flights and other potential damage to the conveyor. Make sure that the conveyor is level in horizontal applications.

Proceed by attaching the head and tail assemblies using the same alignment procedures and precautions noted in the preceding paragraph.

6. Installation

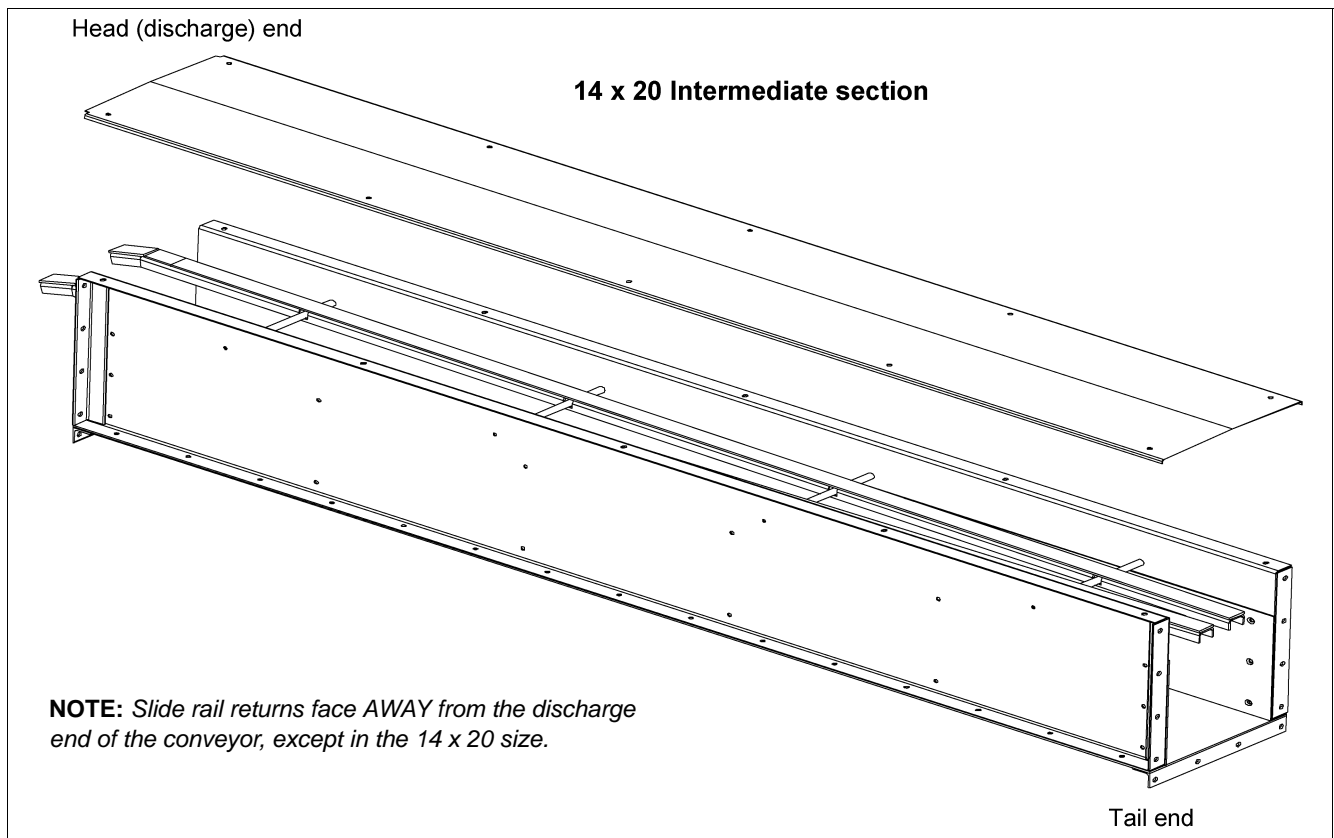

Figure 6E 14 x 20 Intermediate Trough Section Assembly with Slide Rail Returns

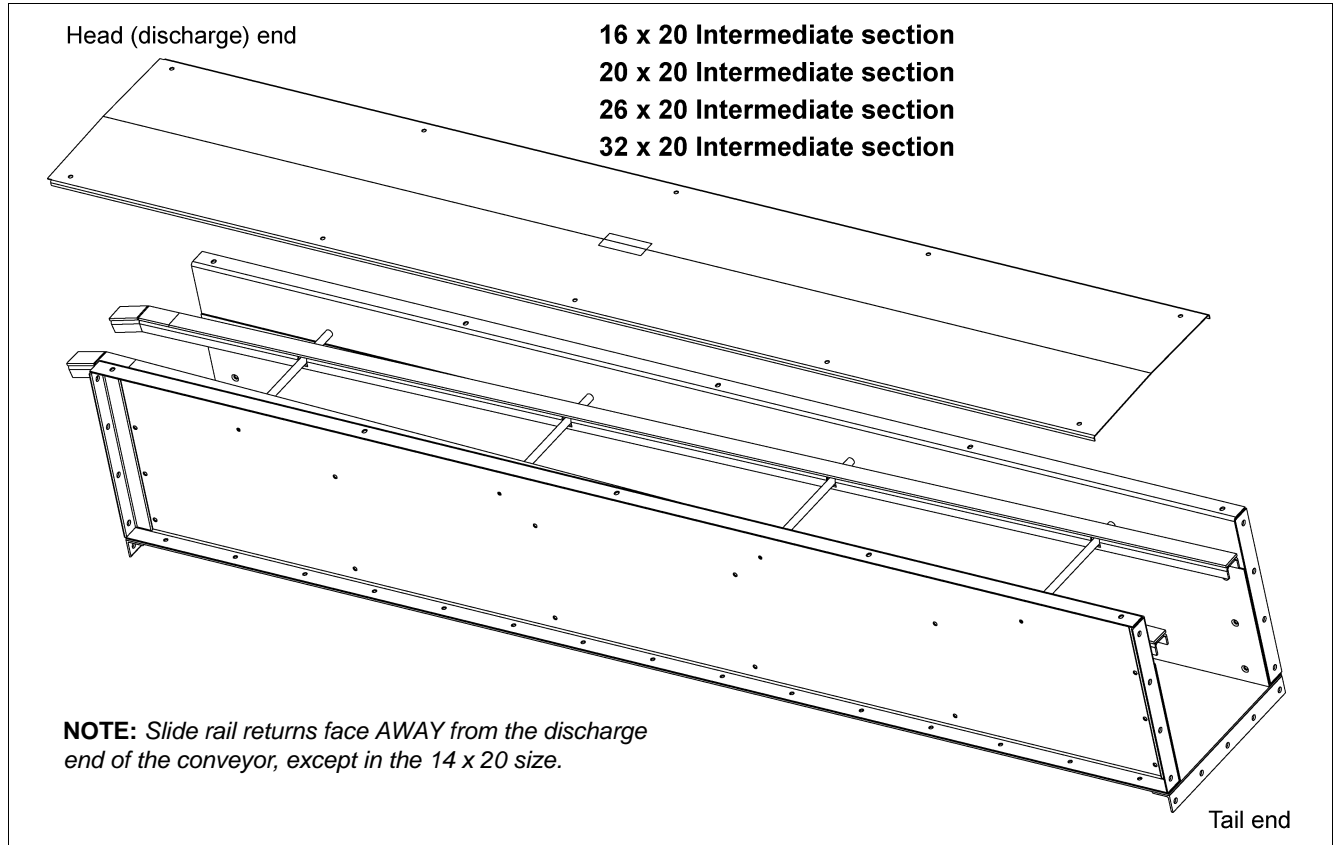

Figure 6F 16, 20, 26, 32 x 20 Intermediate Trough Section Assembly with Slide Rail Returns

Cover Assembly Installation

Before installing the covers, apply adhesive backed foam strip to provide a seal against the elements. Starting at the tail assembly, place the tail section cover on top of the tail section assembly. Apply the adhesive back foam strip to the top surface of the protruding lip before installing the next cover. See cover trough assembly *in Figure 6G*. This recommended installation sequence should ensure that water will shed away from cover seam connections.

When an inlet is on the conveyor, a cover section may have to be cut accordingly to accommodate the inlet. For installation of an inlet, *see Inlet Assembly and Installation on Page 18*.

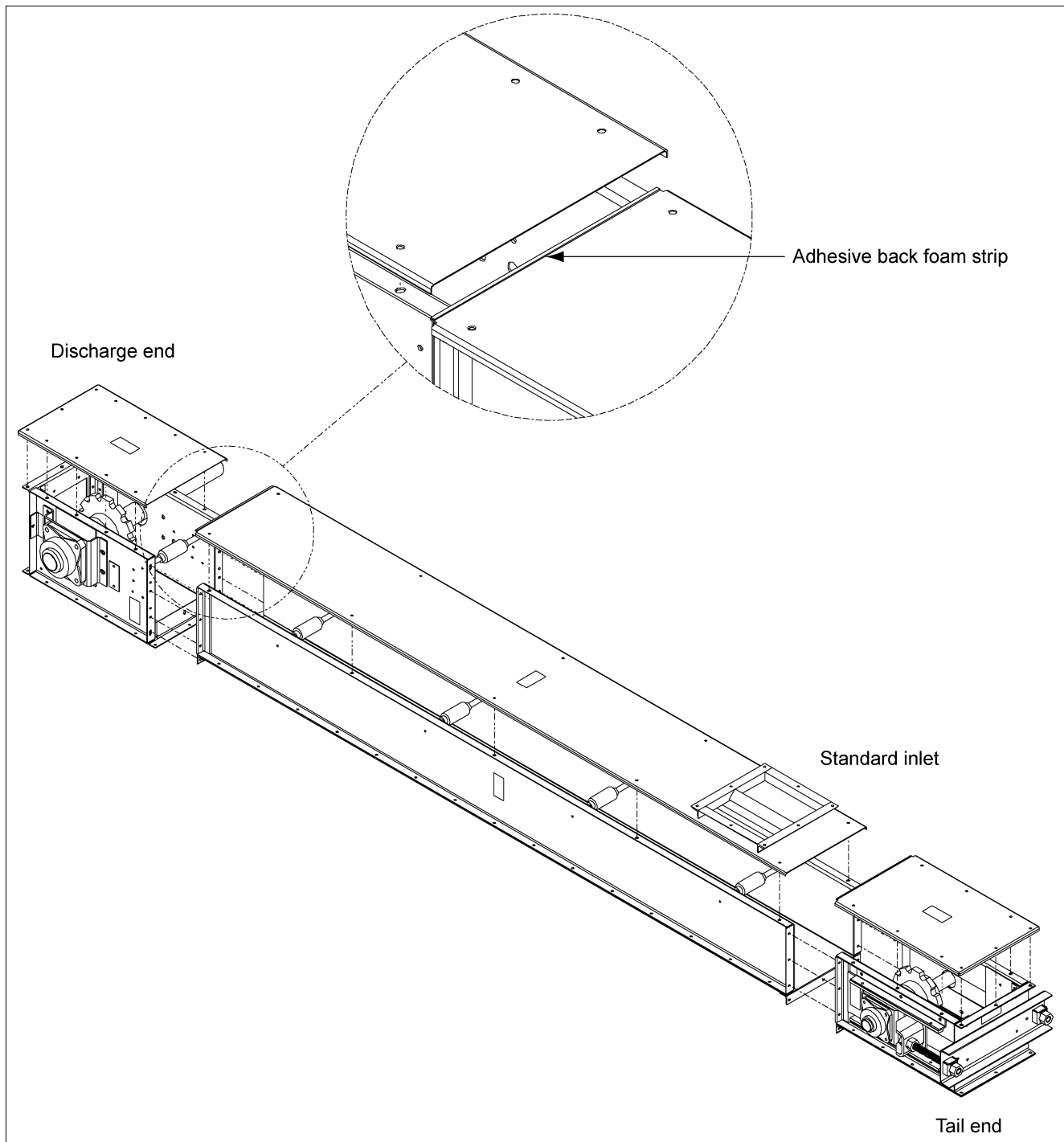

Figure 6G Cover Trough Assembly

Inlet Assembly and Installation

GSI's recommendation for inlet installation includes a minimum distance of not less than 6" between the closest edge of the inlet and the tail assembly.

The inlet can be attached with continuous weld seams. If intermittently welded, it is important to use caulking or sealing around the inlet area in order to seal the unit.

Similarly, GSI recommends that if inlets are welded onto the conveyor, this procedure should occur prior to installation of motor and/or other electrical devices. If the owner fails to follow this precaution, the owner assumes all risks associated with this installation.



REMOVE PAINT BEFORE WELDING OR CUTTING.

Avoid hazardous fumes that can be generated when paint is heated by welding or torching. Do all work outside or in a well-ventilated area. Dispose of paint and solvent properly.

Remove paint before welding or heating:

- **If you use sand or grind paint, avoid breathing the dust. Wear an approved respirator.**
- **If you use solvent or paint stripper, remove stripper with soap and water before welding. Remove solvent or stripper containers and other flammable material from area. Allow fumes to disperse for at least 15 minutes before welding or heating.**

Drag Chain Assembly Installation

All chain supplied with new conveyors will be installed in a similar manner, regardless of type. Correct total chain length has been determined for the installation. The 81X (2.609" pitch) conveyor drag chain is shipped in lengths of approximately 10 feet (10') with an additional pre-cut short section, if necessary (refer to packing list). The 4" pitch chain is shipped with one (1) 10' length or two (2) 5' lengths with cottered links needed for chain take-up. Always install these sections as they are required for shortening the chain.

Position the chain over the roller return assemblies and the sprockets in the head and tail assemblies. The UHMW wear pads should be in front of the welded chain flights in the direction of chain travel. (See [Figure 6H.](#)) Connect chain lengths together with connecting links and/or pins. This assembly also applies to conveyors with slide rail returns.

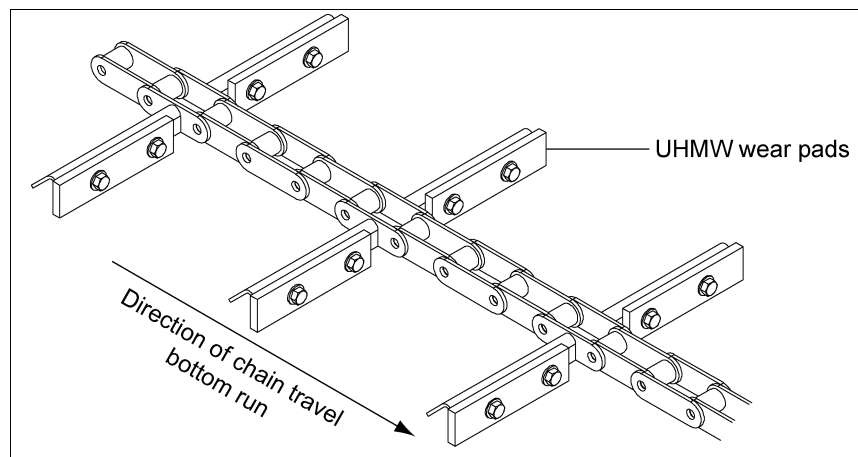

Figure 6H 81X Chain Assembly

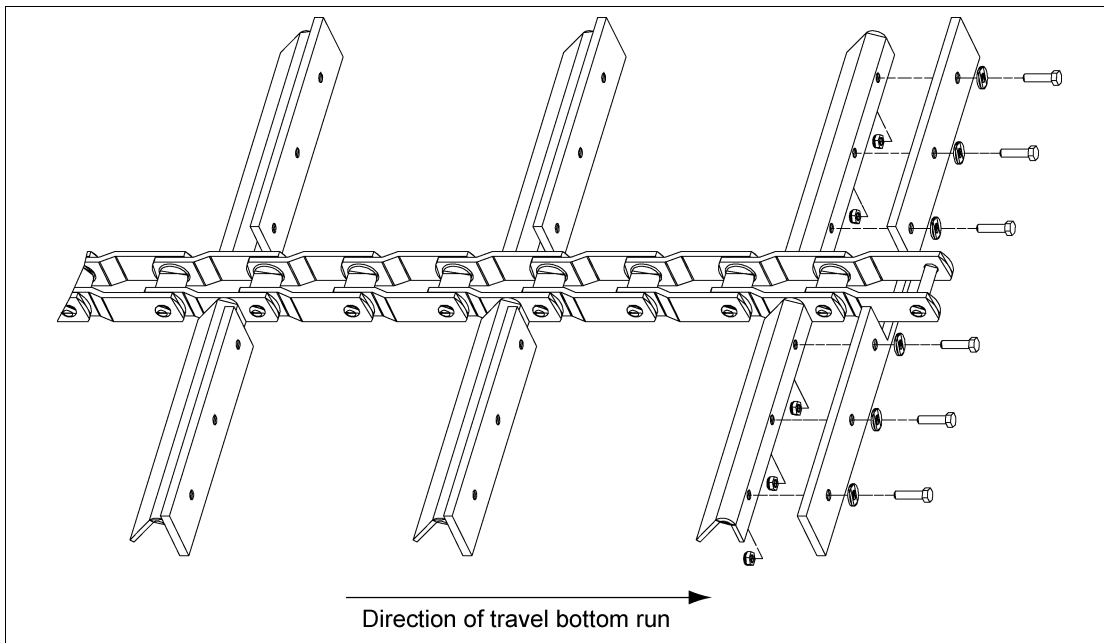

Figure 6I 4" Pitch Roller Chain Assembly

Tighten the drag chain assembly using the take-up screws located on each side of the tail section or on the take-up head. On conveyors with roller returns, the chain is at the proper tension when a maximum of 1/2" deflection occurs at a point midway between the rollers. (See [Figure 6J.](#)) On conveyors with slide rail returns, the chain should be able to be lifted slightly when sufficiently tightened. After the chain is tight, check that the head and tail shafts are square to the box sides. If the shafts are not square, loosen the tighter of the two (2) adjuster screws until the shafts are square. Lock the adjuster screws by tightening the hex nuts against the cross-ways "C" channel.

Rotate the chain, now on the sprockets, at least one (1) complete revolution. Check to see that the chain and its wear pads are not catching on flanges or rubbing on the trough sides due to the sprockets not being centered within the box. Ensure a "break-in" period whereby the chain is allowed to run and seat itself. After running it for an adequate period of time, stop the machine, disconnect and lock out the power source. Retighten as necessary and remove any excess chain portions. Repeat this process as necessary.

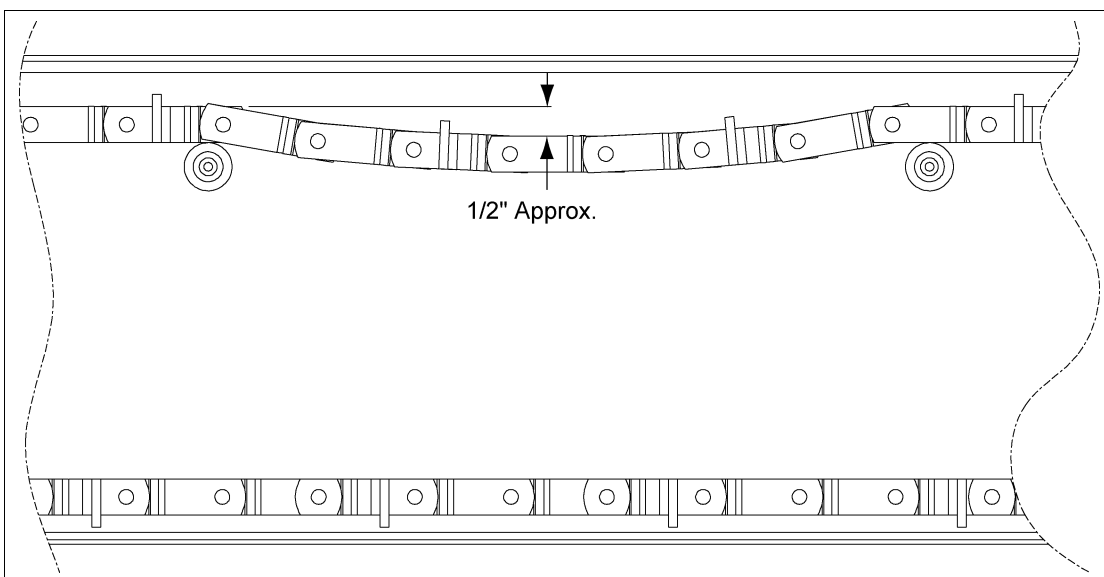

Figure 6J

Motor and Torque Arm II Reducer Installation

Reducer

- To aid in the installation of the reducer onto the shaft, remove any protective coating film from the shaft.
- Place key in the keyway on the drive shaft.
- Attach inside bushing back-up plate and secure with supplied retaining ring to the reducer hub.
- Line up the keyway on reducer with key on shaft and slide the reducer drive onto the drive shaft.
- Slide outside back-up bushing onto shaft and secure with supplied retaining ring to reducer hub. Once reducer drive is in place, fully tighten both bushings.

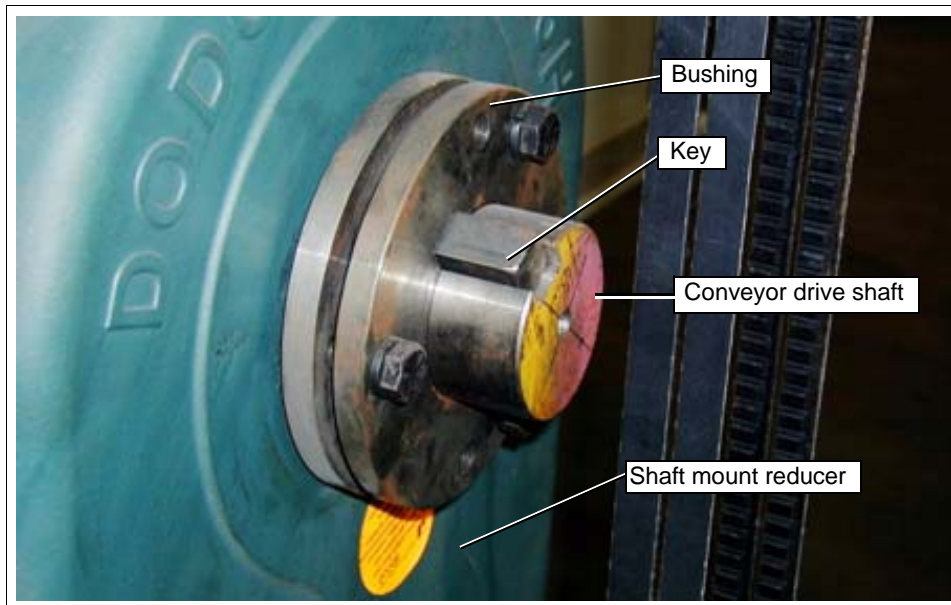

Figure 6K

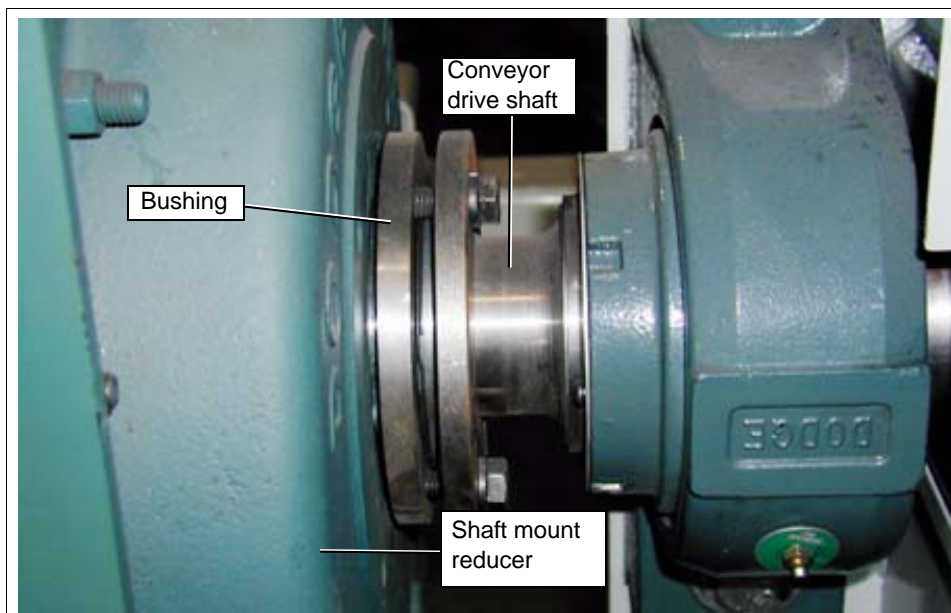

Figure 6L

Motor and Torque Arm II Reducer Installation (Continued)

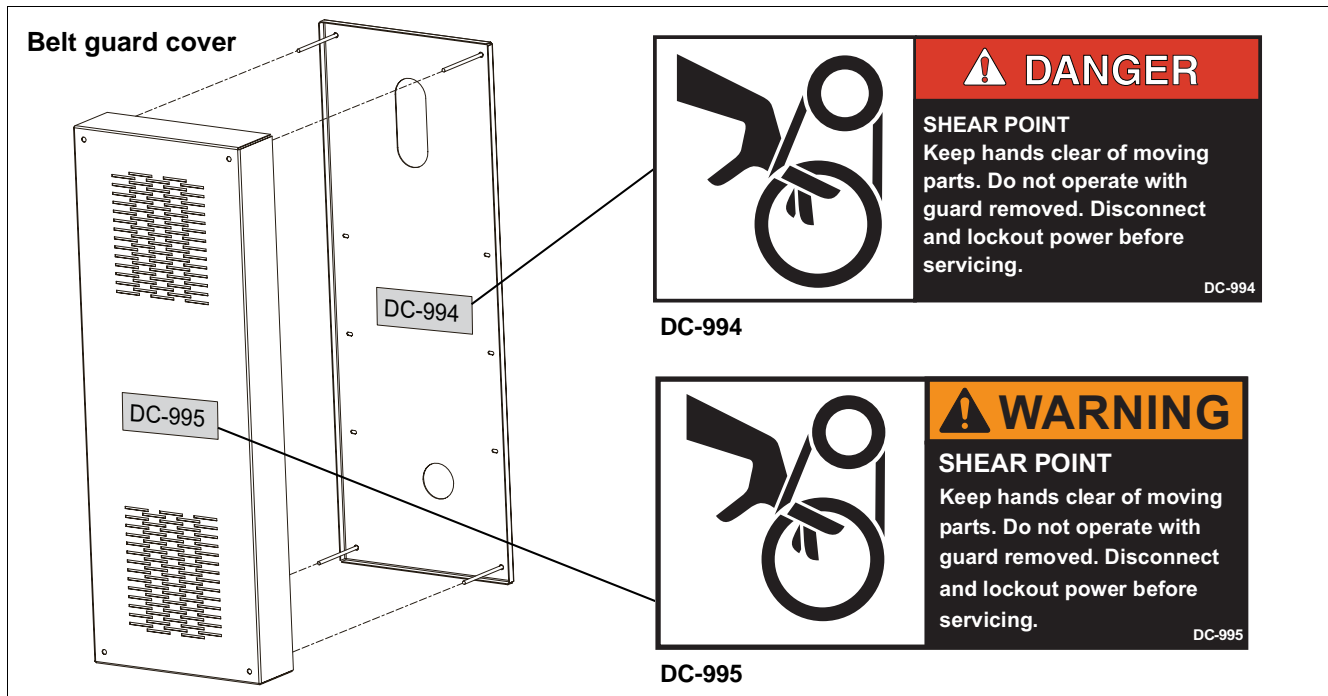

Figure 6M

Torque Arm Turnbuckle Assembly

Install the torque arm turnbuckle between the two (2) plates that are located on the bottom of the reducer drive. (See [Figure 6P on Page 22.](#)) Secure using bolt with washer and lock nuts. (See [Figure 6N on Page 22.](#)) Attach the other end to the torque arm bracket on the conveyor using two (2) bolts, washers, and lock nuts. Tighten the torque arm by turning the turnbuckle. (See [Figure 6Q on Page 22.](#)) Adjust the position of the reducer.

Torque Arm Bracket Installation

When a drive package is ordered with the conveyor system, a torque arm bracket is provided.

The torque arm bracket is pre-punched for easy installation to the unit. Begin installation of this option by determining the location of the torque arm bracket relative to the range of extension allowed by the shaft mount reducer's torque arm. The bracket will extend on the same side of the conveyor as the head shaft. Remove the four (4) bolts from the bottom of the conveyor plate as necessary.

NOTE: *Drill four (4) holes in the conveyor's bottom to accommodate the 5/8" hardware provided. Attach the torque arm bracket to the conveyor using four (4) 5/8" hardware. DO NOT use the 3/8" bolts previously removed from the conveyor bottom to attach the torque arm to the conveyor.*

Install shaft mount reducer to head shaft using the instructions on [Page 20.](#)

Next, match the size of the hardware to the reducer manufacturer's torque arm. Use this hardware to attach the torque arm to the bracket. Adequately tighten all hardware.

The torque arm bracket is mounted under the first intermediate section. Locate bracket by matching an existing set of holes in the intermediate side that allows the turnbuckle assembly to be as short as possible with the reducer in a vertical position. (See [Figure 6P on Page 22.](#))

Motor and Torque Arm II Reducer Installation (Continued)

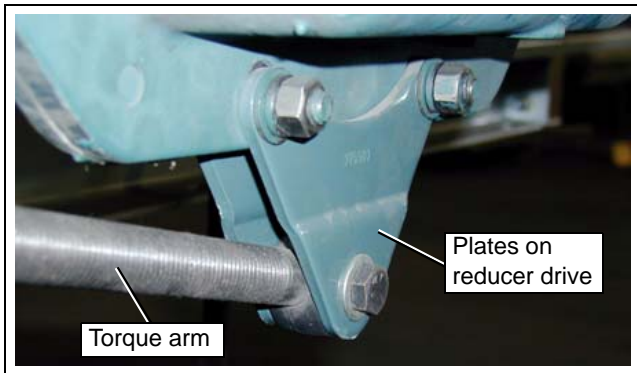

Figure 6N

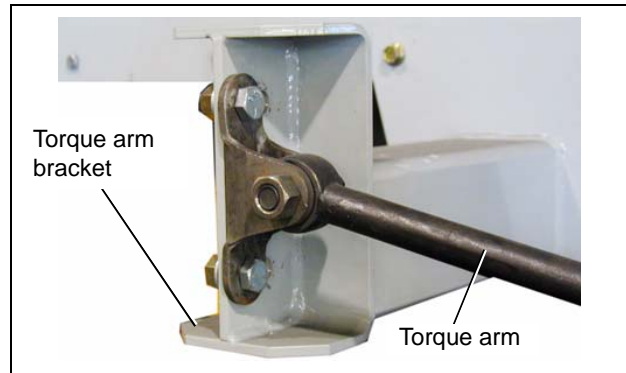

Figure 6O

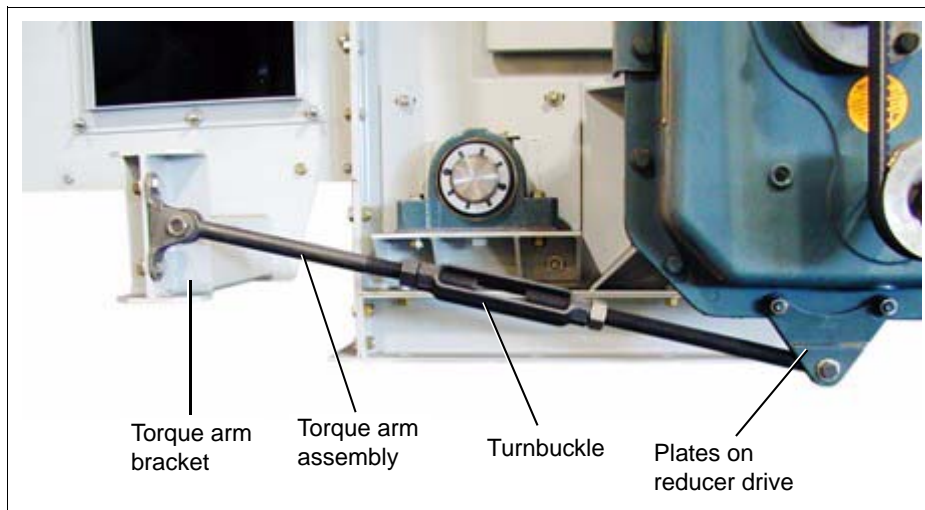

Figure 6P

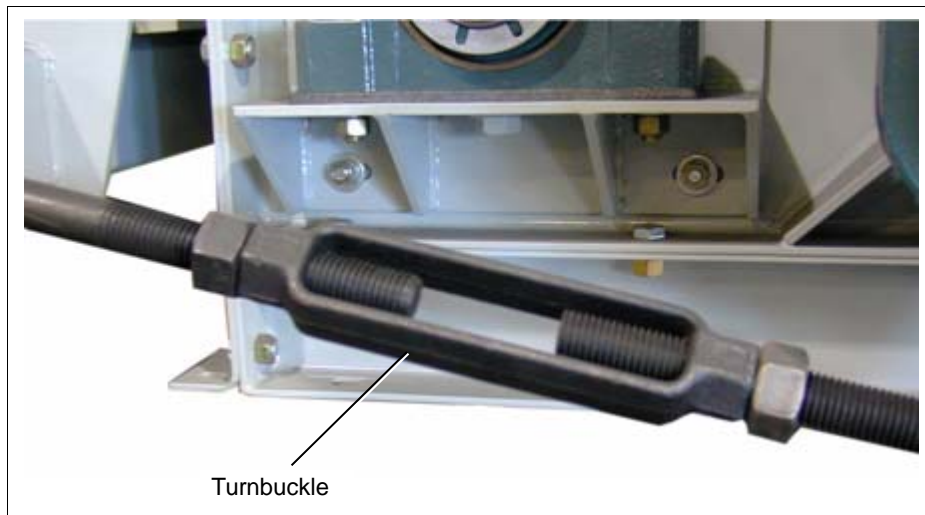

Figure 6Q

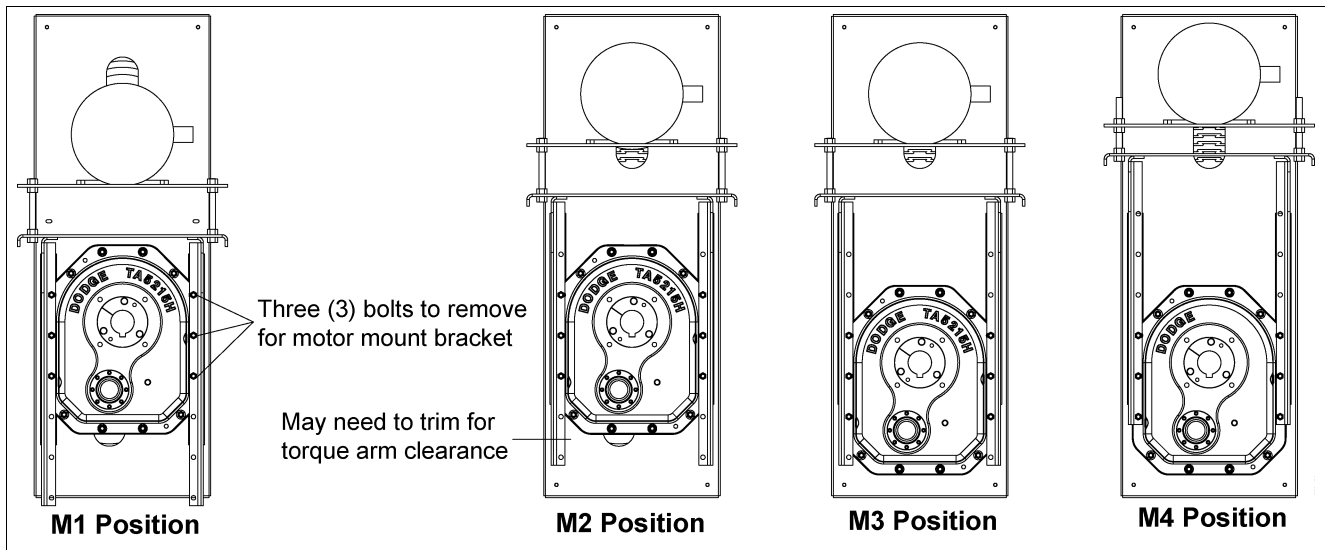

Figure 6R

How to Break Down the Drive Package Number to Locate Motor Mount Position

# Sequence Positions											
1	2	3	4	5	6	7	8	9	10	11	12

# Sequence Positions	Description
Position #1	“D” is for drive package
Position #2	Horsepower
Position #3 and #4	Output RPM
Position #5	Input motor RPM (x 100) “8” = 1750 RPM @ 60 HTZ “5” = 1450 RPM @ 50 HTZ
Position #6	Manufacturer; “T” for TAIL reducer
Position #7	Motor mount configuration: “1” = M1 Position “2” = M2 Position “3” = M3 Position “4” = M4 Position
Position #8	Reducer bushing bore size. Refer to alpha code below. Reducer bushing bore sizes: “A” = 1-7/16” “B” = 1-15/16” “C” = 2-3/16” “D” = 2-7/16” “E” = 2-15/16” “F” = 3-7/16” “G” = 3-15/16” “H” = 4-7/16” “I” = 4-15/16”
Position #9	Drive configuration. “V” = V-belt drive. “H” = HTD belt drive.
Position #10	Drive class (“1” or “2”).
When a drive package for 100 horsepower or greater is needed, the digit sequence will shift one (1) character to the right.	

6. Installation

Motor Mount Brackets

Remove three (3) bolts from each side of the reducer housing. Use a set of holes in the motor mount upright brackets that allows the motor plate to be as close as possible to the top of the conveyor. (See Figure 6S.) Check this location by temporarily positioning the belt guard on the reducer with the hole in the guard centered over the reducer input shaft. This will show the correct motor position for the lengths of V-belts provided. Attach by replacing bolts through brackets and housing. Tighten bolts securely. (NOTE: Motor mount angle may have to be trimmed for torque arm.) (See Figure 6R on Page 23.)

Motor Mount Adjustment Plates

- Thread nuts onto jack screws. (See Figure 6T.) Place bolt through motor mount bracket and base plate. Thread another nut onto jack screws to secure. Repeat for three (3) remaining jack screws.
- Thread another nut onto all four (4) jack screws. Place adjustment plate onto jack screws. Thread another nut onto each jack screw to secure adjustment plate. Use these nuts to adjust the motor height.
- Attach the motor to the adjustment plate using bolts and lock nuts.

Drive Guard Rear Panel

Install the rear panel of the drive guard before mounting the sheaves. The rear panel has two (2) mounting brackets with slotted holes. Attach the left-hand and right-hand belt guard mounting brackets to the motor mount frame. Then fasten rear panel of belt guard to the belt guard brackets. After the rear panel is in place, install sheaves onto motor and reducer.

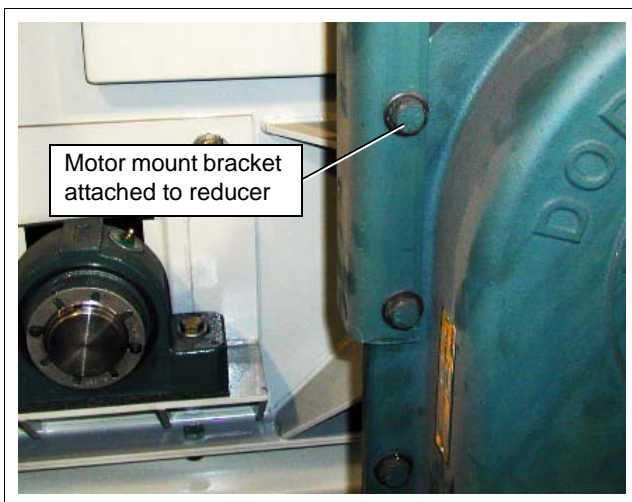

Figure 6S

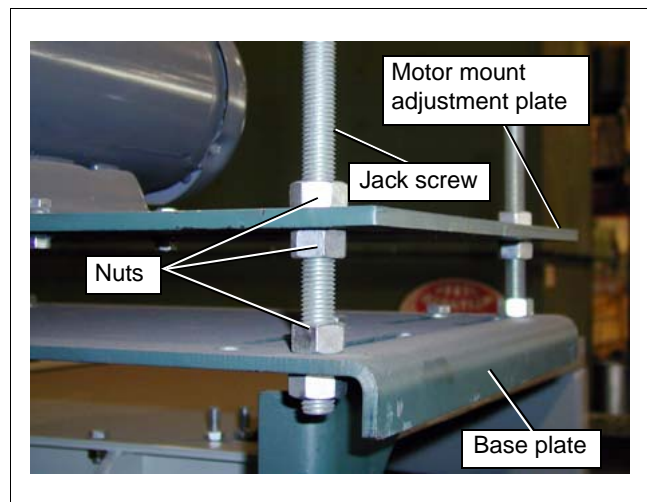

Figure 6T

Sheaves and Belts

Assemble the V-belt driven sheave to the input shaft of the shaft mount reducer. Insert the bushing into sheave hub. Match holes in bushing and hub (not threads). Put screws into holes that are farthest apart. Slip entire unit with key onto shaft. Align the driver and driven sheaves and tighten the retaining screws. During tightening, it is possible for the sheave to move out of alignment or become out of square. For maximum V-belt life, the driven sheave should remain both perpendicular to the drive shaft and aligned with the drive sheave. Slip the V-belts over both the driver and driven sheaves.

V-Belt Adjustment

Adjustment of V-belt tension is achieved by tightening the hex nuts located on the four (4) jack screws of the motor base. Adjust motor base equally at all four (4) jack screws to maintain shaft alignment. Belts are designed to fit loosely upon installation. When the V-belt tension is correct, tighten the top nut on the jack screws to lock the motor base in position. Proper tension is $1/64$ " of deflection per one inch (1") of sheave centers on one side of belt, centered between sheaves. (See Figure 6U.)

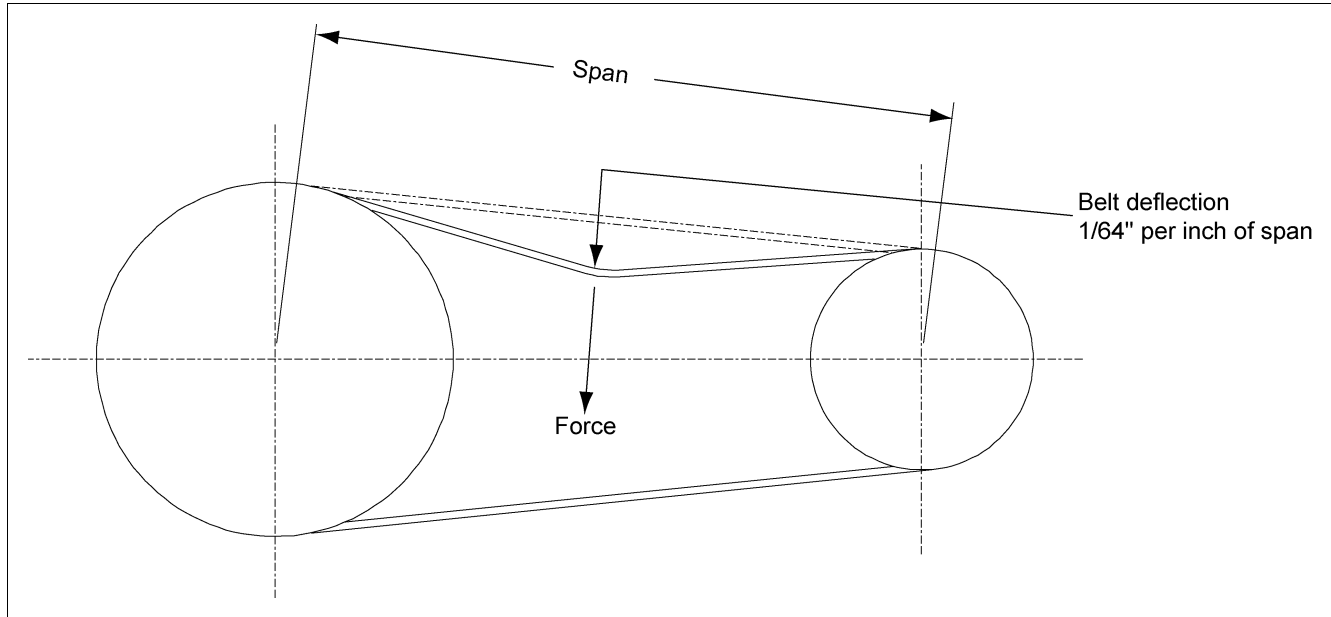

Figure 6U

Front Guard Panel

Install the front drive guard panel over the four (4) corner mounting studs. Secure with washers and nuts provided.

Lubricate Reducer Drive

Fill the shaft mount reducer with the manufacturer's recommended oil.

NOTE: *Too much tension shortens belt life. Check belt tension frequently during the first 24-48 hours of operation.*

Sample Deflection Problem:

3-1/2' Span = $21/32$ " of Deflection (approximately $11/16$ ")

1. $3-1/2' = 42$ " (Span)
2. $1/64" = 0.015625$ " (Belt Deflection per inch of Span)
3. $42" \times 0.015625" = 0.65625$ " (Span x Belt Deflection)
4. $0.65625" = 21/32$ " of Deflection for 3-1/2" Span

7. Care and Maintenance



Before any maintenance is performed on the conveyor, power must be shut OFF and locked out to prevent accidental start up.

The care and maintenance section is provided to help extend the life of the unit. Like all equipment, the useful life of the conveyor is greatly reduced if not used properly and well-maintained.

Please follow the next few simple steps to ensure the safety and longevity of the equipment.

1. Check all bearings and moving parts daily during use.
2. Lubricate bearings at regular intervals to bearing manufacturer's recommendations. If one (1) bearing is re-lubricated, all other bearings should also be lubricated. Do not over lubricate as this will destroy bearing seals.
3. Follow manufacturer's recommendations for gear reducer lubrication and maintenance.
4. Inspect the V-belts periodically for proper tension and wear. V-belts should be replaced as necessary. If replacement or tension adjustment is required, please refer to the [Shaft Mount Reducer Assembly Section on Page 14](#).

Welding



Remove paint before welding or heating. Toxic fumes can be generated when paint is heated by welding, soldering, or using a torch. Always wear an approved respirator and work in well-ventilated area.

Welding on or to the conveyor may cause damage to both the conveyor and its electrical system. If welding is necessary, precautions should be taken to protect the conveyor. If it is necessary to fasten anything to the conveyor permanently, careful consideration should be given to methods of maintenance, removal and replacement of the conveyor and/or its parts.

Motor

Connect the conveyor motor to a power source according to the motor manufacturer's instructions and recommendations. To avoid injury, a certified electrician must perform the motor wiring. A shut off switch should be placed near the motor so that the system may easily be shut down to help prevent accidents during maintenance. It is important to check proper motor shaft rotation before installing drive belts.

Support

Include adequate support for the conveyor assembly to be installed at intervals no greater than 10 feet (10'). It is recommended that supports be installed at vertical portions of flanges leaving bottoms of intermediate sections clear. By attaching supports in this manner, the removable bottoms are unobstructed for ease of replacement. Support legs are available as an option.

Discharge

The standard conveyor is constructed with one (1) discharge located at the drive end. If intermediate discharges are to be used, the location(s) must be determined before proceeding with the conveyor assembly. Intermediate discharges cannot be installed over a trough joint; therefore, it may be necessary to position a shorter trough section to serve as a spacer in order to accommodate the placement of the discharge(s) where they are required. See Inline Gate Manuals (Pneg-765 for instructions for cutting intermediate bottom).

The owner assumes all responsibility for any alterations to the equipment.

If the unit is to be inactive for an extended period, the following procedures are recommended.

1. Thoroughly clean the unit.
2. Loosen the V-belt tension to relieve the stress placed on the bearings and shafts of the drive and tail sections.
3. Lubricate shafts and drive chain components with a good grade of light machine oil.
4. Loosen the drag chain tension to relieve the stress placed on the bearings and shafts of the drive and tail sections.

Installation Instructions (Whirligig - WG1-4B)



Always observe lock out and tag out procedures before, during and after installation.

Do not remove the Whirligig cover. The rotating components under the cover could cause serious injury.

1. Shaft ends are pre-drilled and tapped from the factory.
2. Thread the Whirligig onto the machine shaft using 5/8" open ended wrench and suitable thread locking adhesive (loctite or similar).
3. Install the sensor to the Whirligig base plate. Two (2) sets of pre-drilled holes are provided for M800 sensor. Fit the sensor to leave an approximate 2 mm gap between sensor face and cover.
A universal bracket (WGB18/30) is supplied for fitting 18 mm or 30 mm sensors.
4. Connect the sensor in accordance with manufacturer's instructions and observe all relevant electrical and O.S.H.A., regulations.
5. Fix the flexible strap securely to the static structure (if required).

TIP: The M800 speedswitch and system function can be tested by placing a thin metal plate between the sensor and the cover of the Whirligig. When installing other industry standard sensors, leave a small gap between the sensor and the Whirligig cover for this purpose.

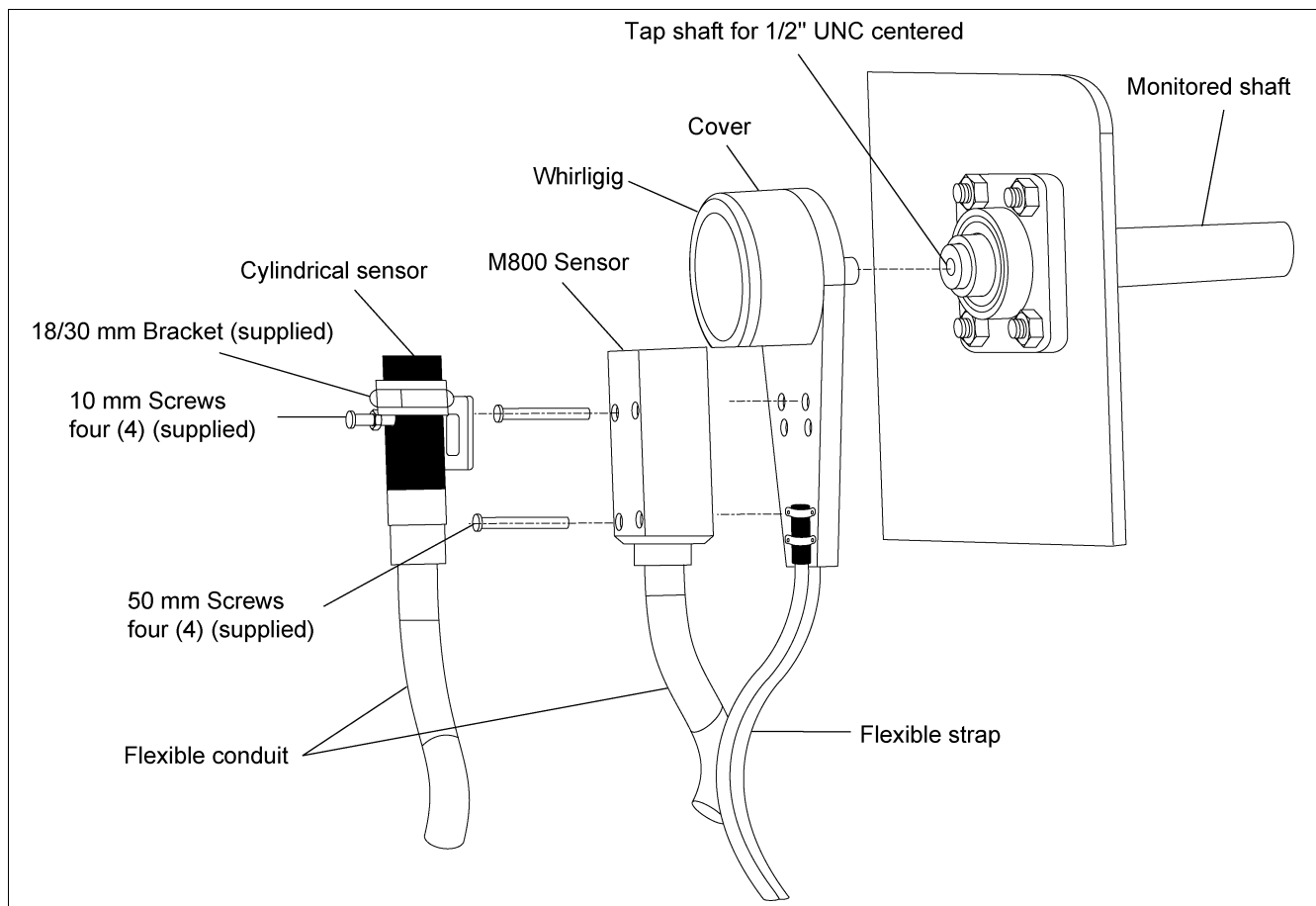

Figure 9A

Inspection Ports

After determining location(s) of inspection port(s) (see [Figure 10A](#)) on conveyor, cut an 8-3/16" square hole in the cover for each inspection port.

Insert inspection port into hole until its frame is flush to the cover. Weld inspection port to conveyor cover. Additional caulking may be required to ensure that water will shed from the inspection port.



Remove paint before welding or heating. Toxic fumes can be generated when paint is heated by welding, soldering, or using a torch. Always wear an approved respirator and work in well-ventilated area.

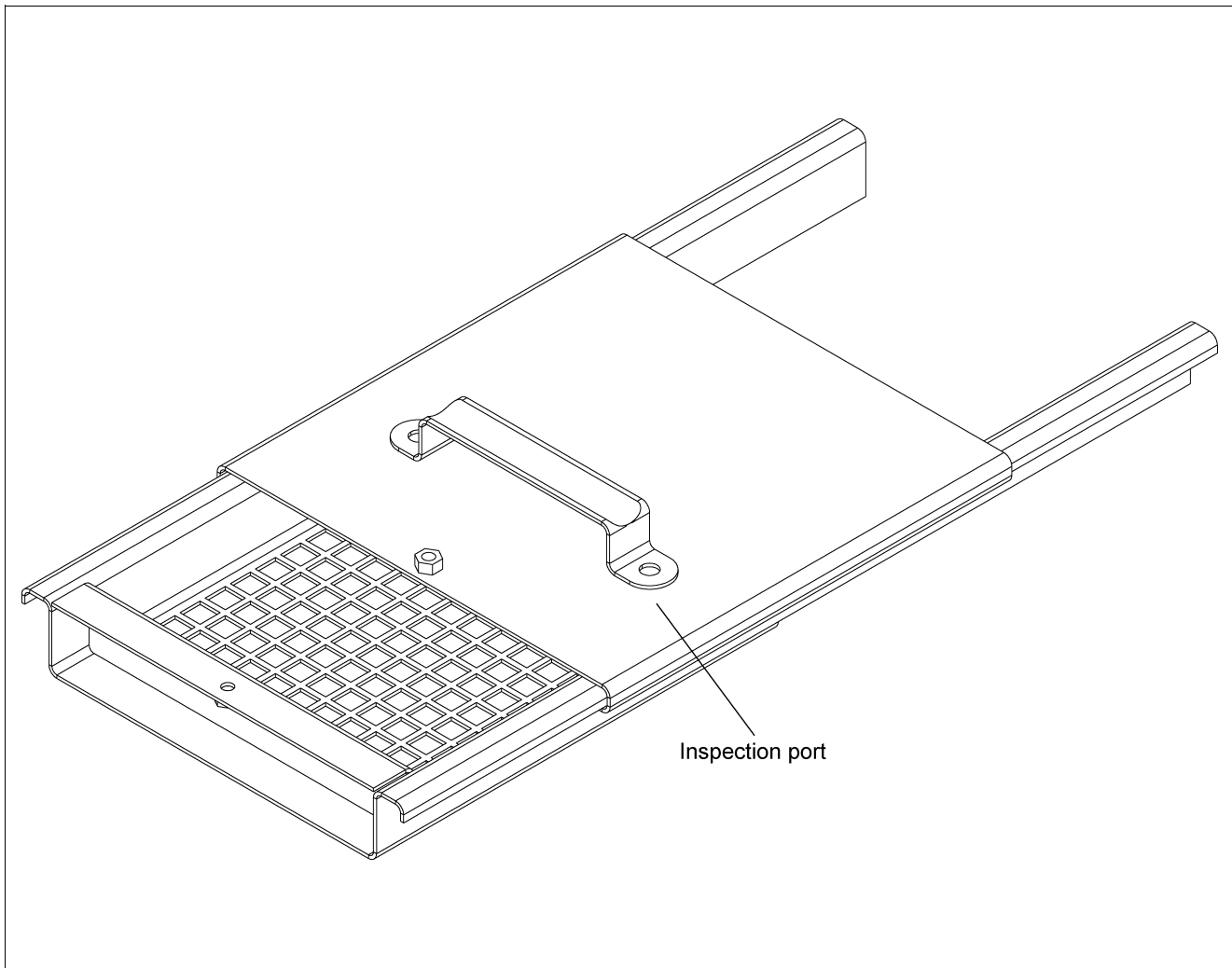

Figure 10A

Plug Relief Door w/o Head Gate

Remove cover plate from head section end channel. When installing plug relief door, be certain that the unit's offset bottom lip is inserted inside the conveyor. Use the existing hardware from the cover plate to attach the plug relief door to the head section. The bolts should be inserted from inside the conveyor to the outside.

Liberal apply the provided sealant around the plug relief door. Follow label directions on sealant cartridge.

Attach limit switch to the plug relief door with the hardware provided. Refer to [Figure 10B](#) for correct orientation.

Adjust the limit switch arm so that the roller actuator keeps sufficient tension against the plug relief door. After the limit switch arm is properly positioned, tighten set screw.

A standard limit switch is shown [in Figure 10B](#). An explosion proof limit switch should be used in extremely dirty or dusty conditions, and/or in enclosed environments.

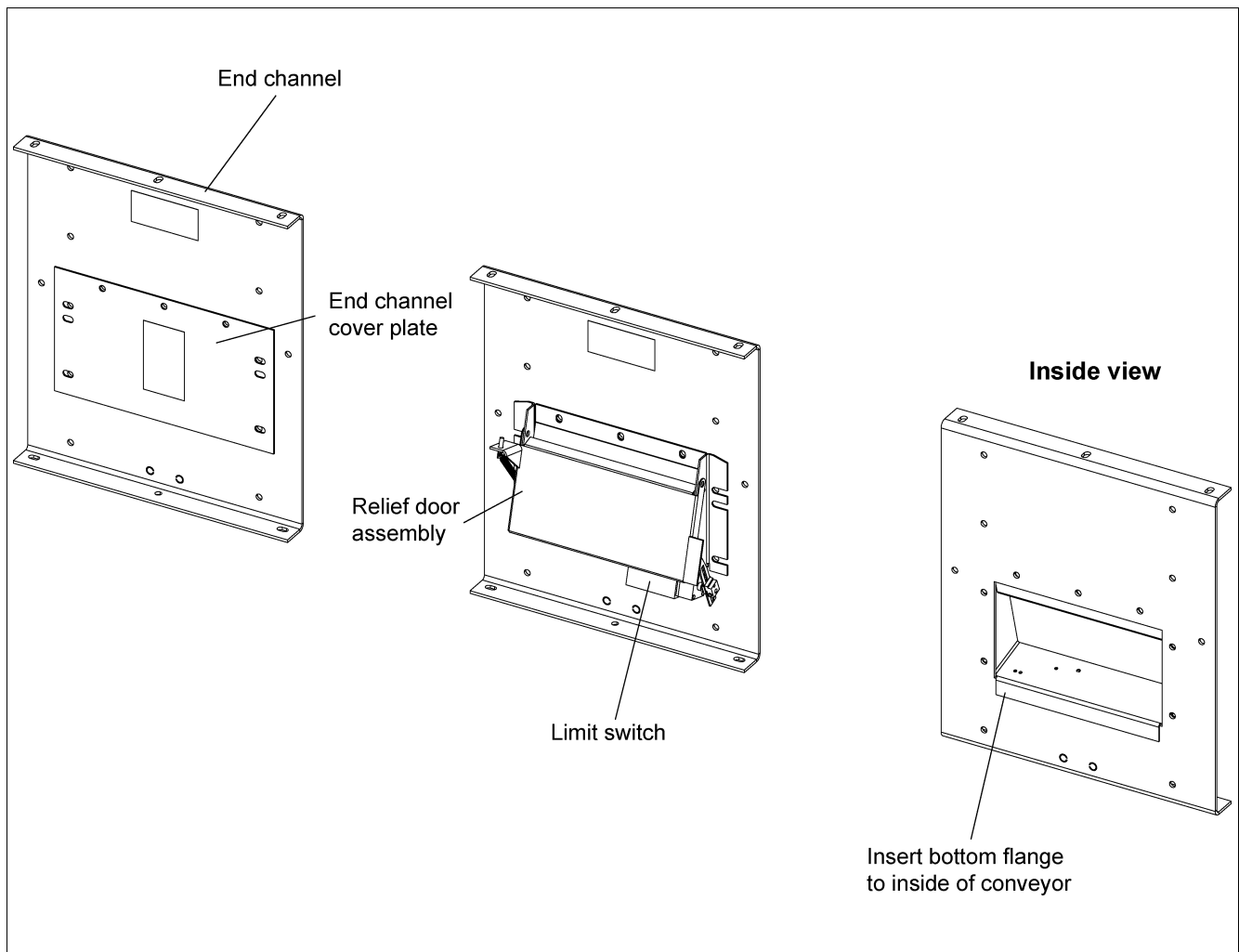

Figure 10B Plug Relief Door

Plug Relief Switch w/ Head Gate

Remove head end plate and replace with anti-plug end plate assembly. Use the existing hardware from the end plate to attach the anti-plug end plate assembly. The bolts should be inserted from the inside of the conveyor to the outside. Refer to [Figure 10C](#) for correct orientation. Anti-plug switches are only used when a head gate is installed.

Adjust the limit switch so that the roller actuator keeps sufficient tension against the anti-plug lever. A standard limit switch is shown in [Figure 10C](#). An explosion proof limit switch should be used in extremely dirty or dusty conditions, and/or in enclosed environments.

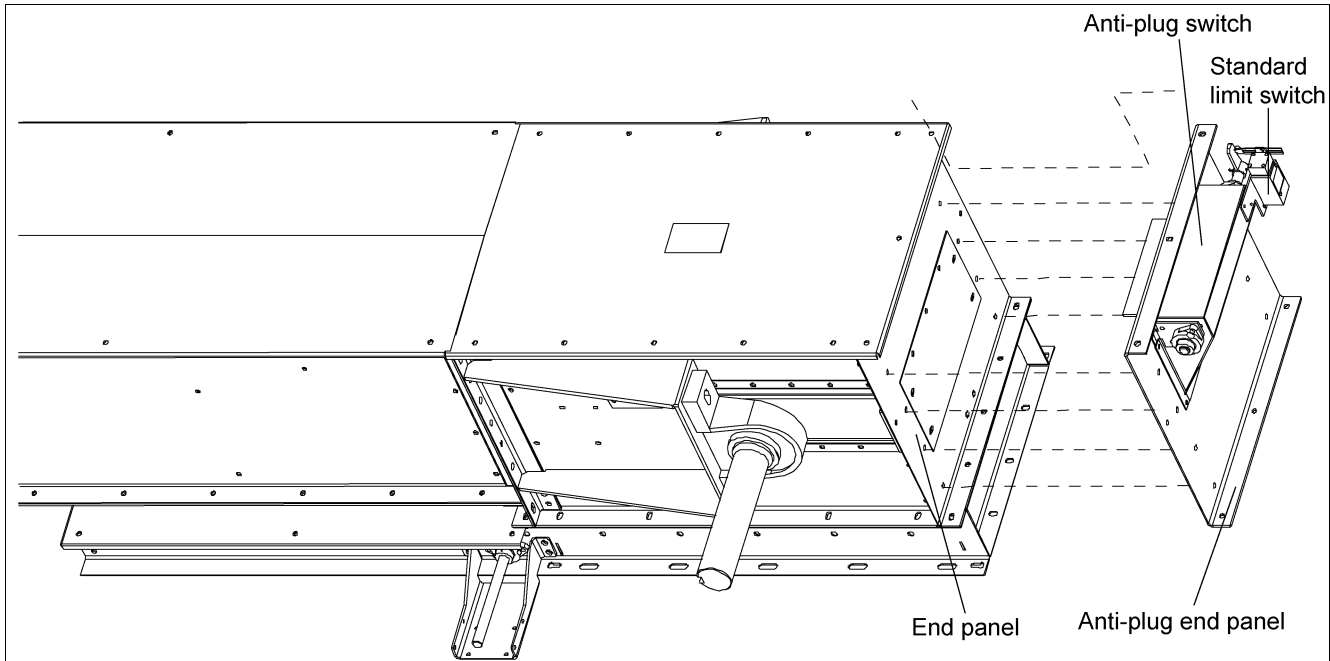

Figure 10C

Slack Chain - Roller Returns

Inspect the slack chain components to verify quantity. A typical slack chain assembly contains:

- One (1) slack chain lever arm weldment
- One (1) internal lever weldment
- Two (2) bearings
- One (1) limit switch clip
- One (1) limit switch
- One (1) spring
- One (1) spring bracket
- One (1) hardware package

Begin installation of optional slack arm assembly by first determining which side of the head section that the limit switch will be attached.

10. Options

Next, remove the two (2) cover plates from the sides of the head section. Attach the two (2) bearings to the sides of the head section. Insert the lever arm weldment through the internal lever weldment and both bearings as shown *in Figure 10D*. Remove any paint, scale or rust from the lever arm weldment rod before assembling. **The internal lever weldment must face away from the head sprocket as shown in the *Figure 10D*.**

Position the external lever arm approximately 4-1/8" from head section side. The lever arm should be oriented horizontally. Tighten locking collars on the bearings.

Attach limit switch bracket to conveyor head section. Note the orientation of the limit switch brackets as illustrated in the *Diagram A in Figure 10D*. Also, please note that some 20" tall conveyors will not use the limit switch clips. The limit switch may be attached directly to pre-punched holes in the bearing plate gussets. (*See Diagram B in Figure 10D.*)

Fasten the limit switch to the clip or gusset with the hardware provided.

Install the spring bracket above the limit switch. Attach the spring to the bracket and to the external lever arm. (*See Figure 10E on Page 33.*)

Finally, center the internal lever weldment between the head section sides. This internal lever should be directly below conveyor drag chain. Orient the internal lever so that approximately one inch (1") is between the lever and the chain. (*See Figure 10F on Page 33.*)

A standard limit switch is shown *in Figure 10D*. An explosion proof limit switch should be used in extremely dirty or dusty conditions, and/or in enclosed environments.

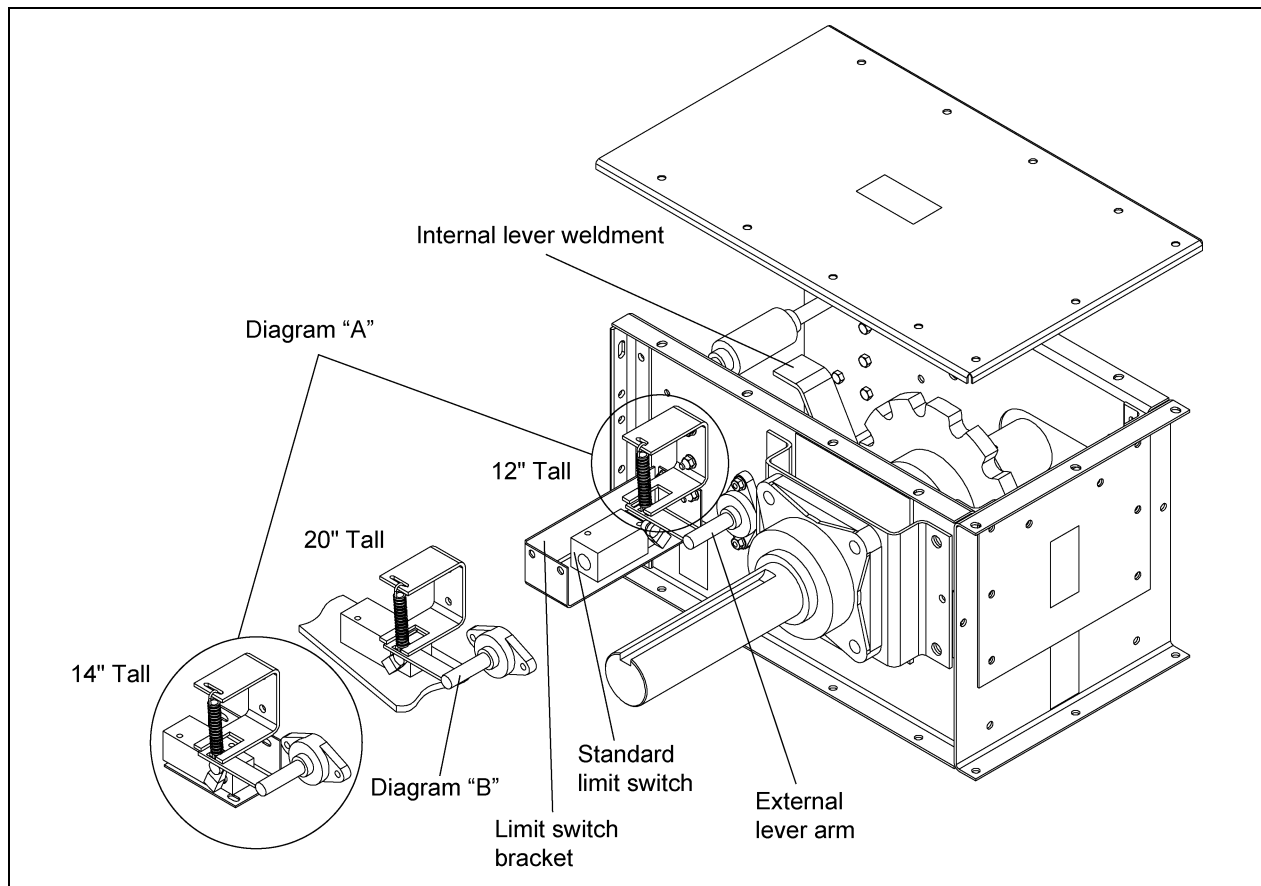

Figure 10D

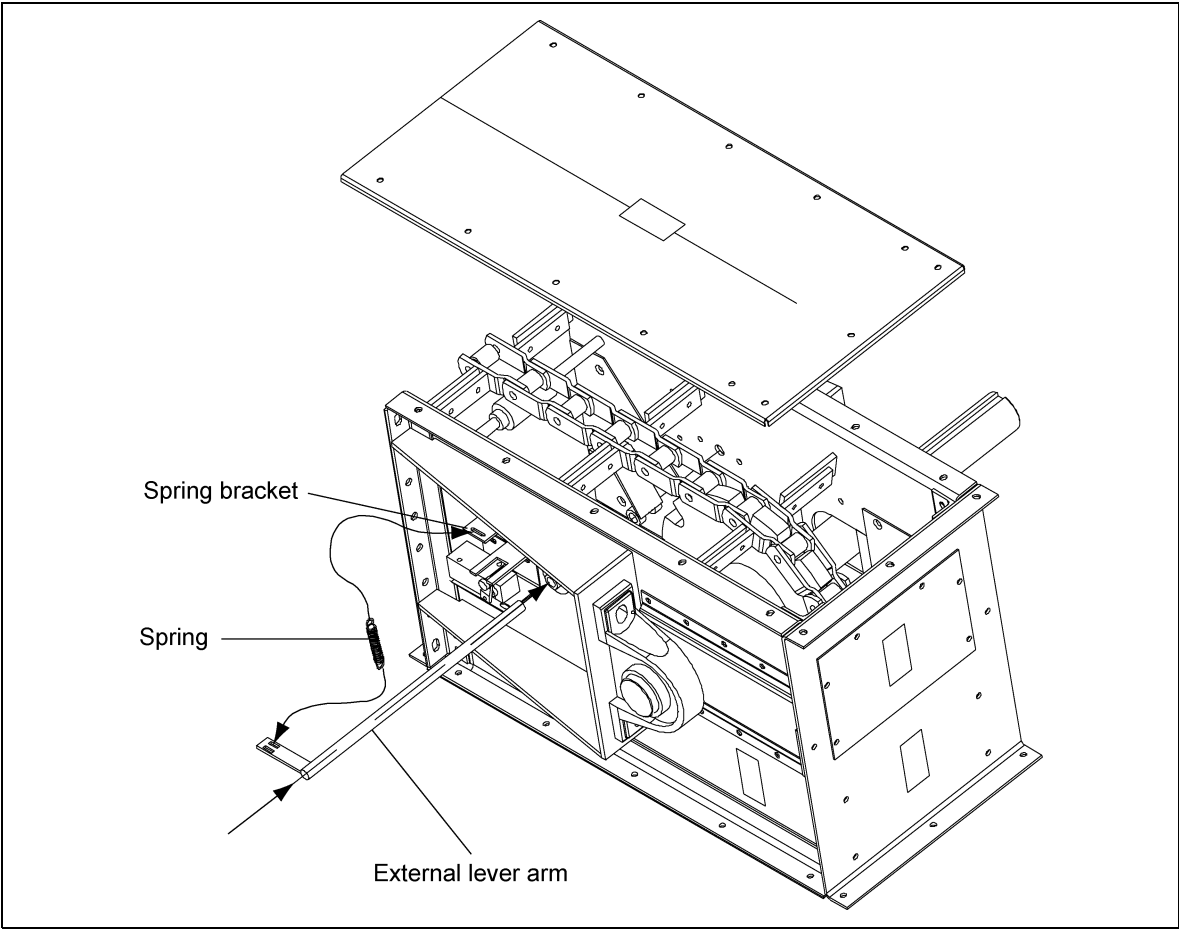

Figure 10E

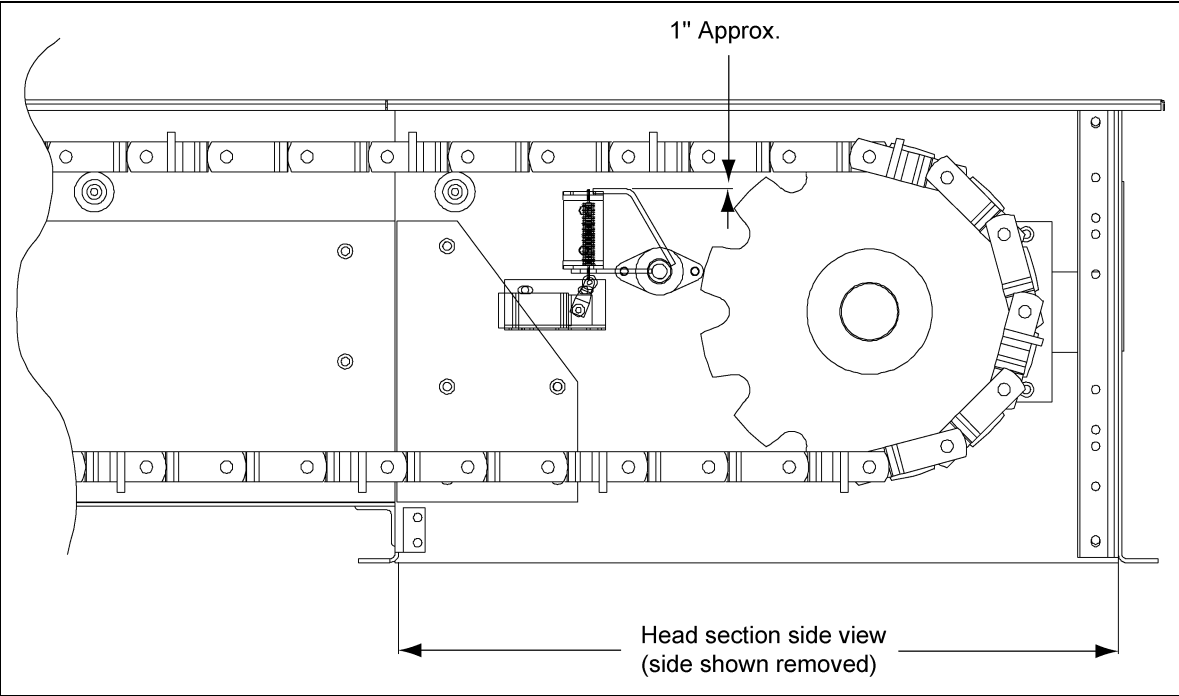

Figure 10F

Slack Chain - Slide Rail Returns

When an en-masse conveyor is equipped with slide rail returns, an optional slack chain detector may be installed. Depending on working conditions and/or environment, either a standard or an explosion proof limit switch is available.

Replace small cover on head with top slack chain detector. (See Figure 10G.)

Before attaching slack chain assembly to the conveyor, apply sealant to bottom surfaces of slack chain assembly.

Fasten slack chain assembly to the conveyor with 3/8" hardware. See Figure 10H regarding direction of slack chain assembly on the conveyor.

After installation, adjust the clearance between the UHMW paddle in the slack chain assembly and the wiper flights on the chain to approximately 1/2"-5/8".

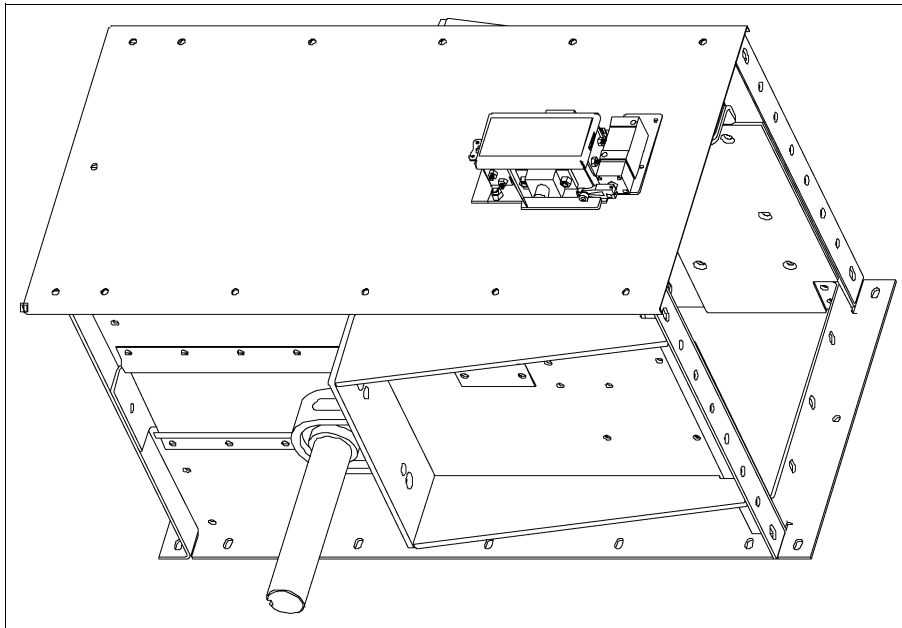

Figure 10G Top Slack Chain Detector

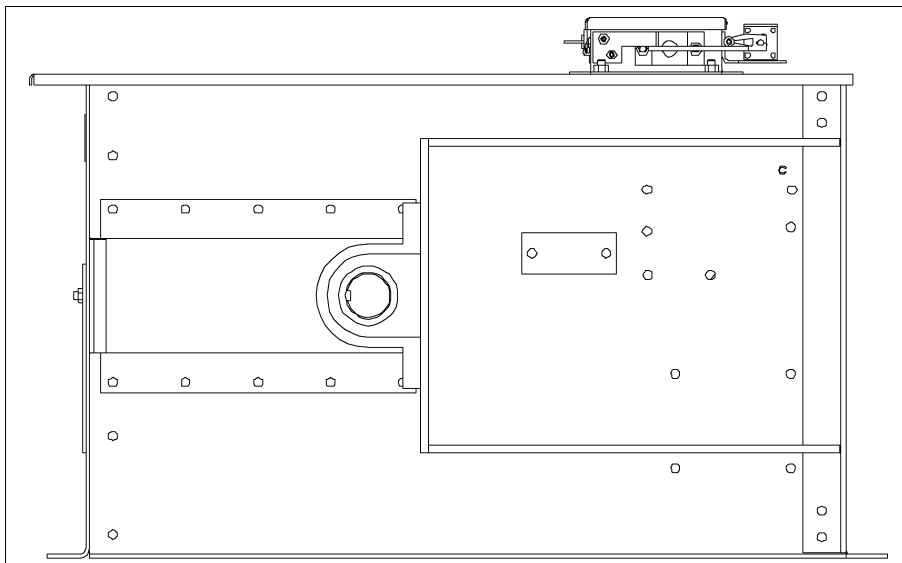

Figure 10H Slack Chain Assembly

Bypass Inlet with Baffles

The bypass baffle has an adjustment of 2-1/2" to help control the amount of grain flow into the conveyor.
(See Figure 10I.)

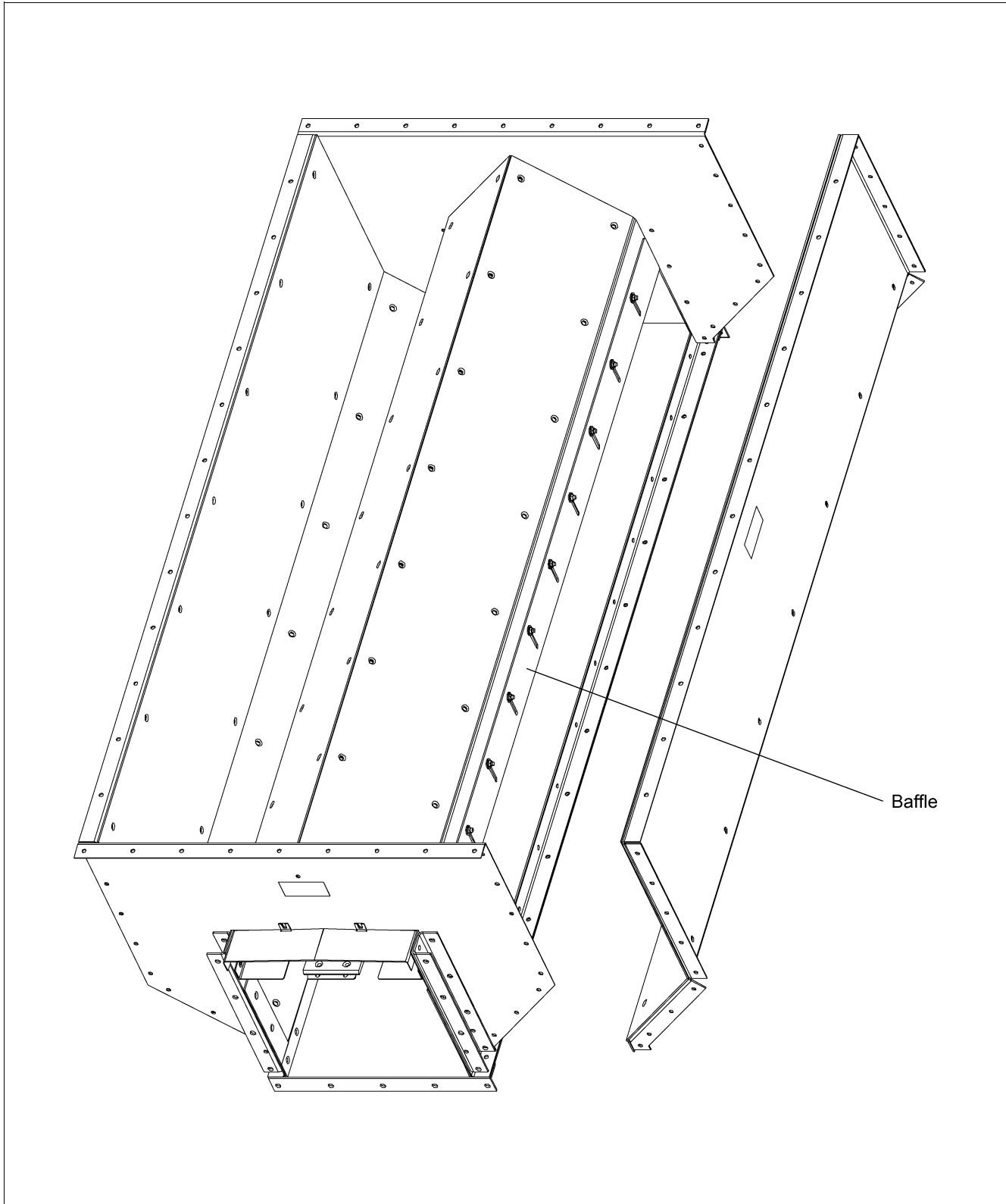

Figure 10I

Head Discharge with Take-Up

For applications where the en-masse conveyor may run in a reversing direction, or where a clean out fixed tail section is supplied, an optional head discharge assembly with take-up may be used.

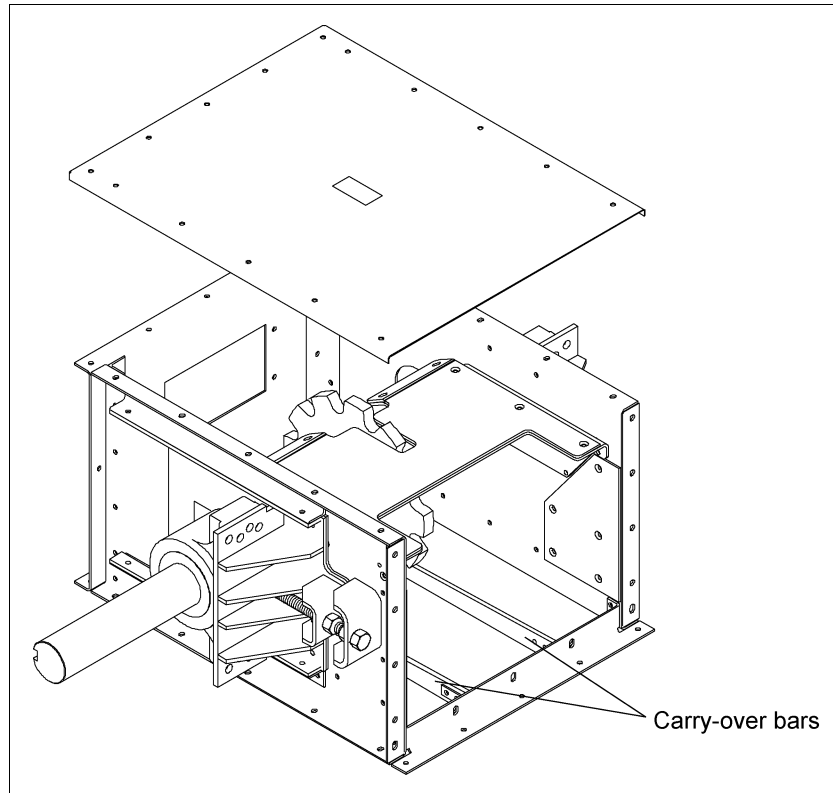

Figure 10J Reversing Take-Up Head with Carry-Over Bars

Carry-Over Bars

On reversing conveyor applications, optional carry-over bars should be installed in both discharge assemblies. These bars help ensure a smooth transition of the chain and flights from the head discharge into the conveyor box.

The carry-over bar package consists of two (2) carry-over bars, two (2) clips, and the hardware required for assembly. To assemble, first remove the 1/2" nuts and bolts from the end panel, and attach two (2) clips to end panel. Then attach carry-over bars to these clips with the 3/8" hardware provided. Next, on the other end of the carry-over bars, determine which 1/2" bolts and nuts to remove by gaging with the remaining clips. Remove the appropriate 1/2" hardware, and attach these clips. Fasten carry-over bars to the clips with 3/8" hardware.

The carry-over bars should be spaced so that they pick up the UHMW flights as shown [in Figure 10K](#).

After installation, adjust carry-over bars so that they are even with the top edge of the bottom plate. *Do not extend carry-over bars above the top surface of the bottom plate.* Tighten all hardware.

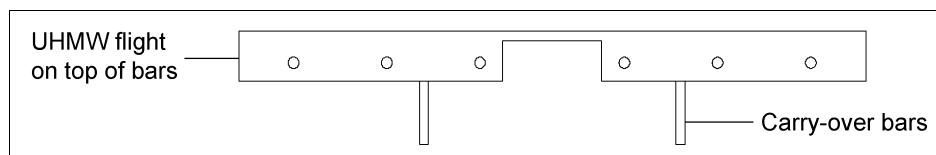

Figure 10K End View of UHMW Flight on Carry-Over Bars

Troubleshooting Guide

Problem	Cause	Solution
Low capacity	<ol style="list-style-type: none"> 1. Improper chain speed. 2. Loose chain. 3. Improper feed. 4. Plugging. 	<ol style="list-style-type: none"> 1. Check the shaft RPM. 2. Check the sag between idlers. 3. Check the grain level at inlet. 4. Check the discharges.
Noisy operation	<ol style="list-style-type: none"> 1. Loose UHMW paddles. 2. Bottom not aligned. 3. Worn return roller. 4. Worn drive components. 5. Worn sprocket. 6. Return rail alignment. 	<ol style="list-style-type: none"> 1. Check all bolts on chain. 2. Check intermediate trough section joints and make flush. 3. Check return idlers; they should turn freely. 4. Check oil level and shaft seals; belt misalignment; loose belts. 5. Replace. 6. Check rail alignment.
Uneven UHMW paddle wear	<ol style="list-style-type: none"> 1. Conveyor misalignment. 2. Sprocket slipped. 3. Return rail alignment. 	<ol style="list-style-type: none"> 1. Check the conveyor alignment. 2. Check set screws on sprockets. 3. Check rail alignment.
Excessive carry-over	<ol style="list-style-type: none"> 1. Gates not fully opening. 	<ol style="list-style-type: none"> 1. Check the gate operation.
Uneven sprocket wear	<ol style="list-style-type: none"> 1. Worn chain. 2. Improper alignment. 3. Material carry-over into discharge sprocket. 	<ol style="list-style-type: none"> 1. Replace chain. <i>(See Page 14.)</i> 2. Check the sprocket alignment. 3. Check for improper location of inlet. <i>(See Page 13.)</i>

Consult the contractor for added assistance.

NOTES



Limited Warranty

The GSI Group, LLC. ("GSI") warrants products which it manufactures to be free of defects in materials and workmanship under normal usage and conditions for a period of 12 months after sale to the original end-user or if a foreign sale, 14 months from arrival at port of discharge, whichever is earlier. The end-user's sole remedy (and GSI's only obligation) is to repair or replace, at GSI's option and expense, products that in GSI's judgment, contain a material defect in materials or workmanship. Expenses incurred by or on behalf of the end-user without prior written authorization from the GSI Warranty Group shall be the sole responsibility of the end-user.

Warranty Extensions: The Limited Warranty period is extended for the following products:

	Product	Warranty Period
AP Fans and Flooring	Performer Series Direct Drive Fan Motor	3 Years
	All Fiberglass Housings	Lifetime
	All Fiberglass Propellers	Lifetime
Cumberland Feeding/Watering Systems	Feeder System Pan Assemblies	5 Years **
	Feed Tubes (1.75" & 2.00")	10 Years *
	Centerless Augers	10 Years *
	Watering Nipples	10 Years *
Grain Systems	Grain Bin Structural Design	5 Years
Grain Systems Farm Fans Zimmerman	Portable & Tower Dryers	2 Years
	Portable & Tower Dryer Frames and Internal Infrastructure †	5 Years

* Warranty prorated from list price:
 0 to 3 years – no cost to end-user
 3 to 5 years – end-user pays 25%
 5 to 7 years – end-user pays 50%
 7 to 10 years – end user pays 75%

** Warranty prorated from list price:
 0 to 3 years – no cost to end-user
 3 to 5 years – end-user pays 50%

† Motors, burner components and moving parts not included. Portable Dryer screens included. Tower Dryer screens not included.

GSI further warrants that the portable and tower dryer frame and basket, excluding all auger and auger drive components, shall be free from defects in materials for a period of time beginning on the twelfth (12th) month from the date of purchase and continuing until the sixtieth (60th) month from the date of purchase (extended warranty period). During the extended warranty period, GSI will replace the frame or basket components that prove to be defective under normal conditions of use without charge, excluding the labor, transportation, and/or shipping costs incurred in the performance of this extended warranty.

Conditions and Limitations:

THERE ARE NO WARRANTIES THAT EXTEND BEYOND THE LIMITED WARRANTY DESCRIPTION SET FORTH ABOVE. SPECIFICALLY, GSI MAKES NO FURTHER WARRANTY OF ANY KIND, EXPRESS OR IMPLIED, INCLUDING, WITHOUT LIMITATION, WARRANTIES OF MERCHANTABILITY OR FITNESS FOR A PARTICULAR PURPOSE OR USE IN CONNECTION WITH: (i) PRODUCT MANUFACTURED OR SOLD BY GSI OR (ii) ANY ADVICE, INSTRUCTION, RECOMMENDATION OR SUGGESTION PROVIDED BY AN AGENT, REPRESENTATIVE OR EMPLOYEE OF GSI REGARDING OR RELATED TO THE CONFIGURATION, INSTALLATION, LAYOUT, SUITABILITY FOR A PARTICULAR PURPOSE, OR DESIGN OF SUCH PRODUCTS.

GSI shall not be liable for any direct, indirect, incidental or consequential damages, including, without limitation, loss of anticipated profits or benefits. The sole and exclusive remedy is set forth in the Limited Warranty, which shall not exceed the amount paid for the product purchased. This warranty is not transferable and applies only to the original end-user. GSI shall have no obligation or responsibility for any representations or warranties made by or on behalf of any dealer, agent or distributor.

GSI assumes no responsibility for claims resulting from construction defects or unauthorized modifications to products which it manufactured. Modifications to products not specifically delineated in the manual accompanying the equipment at initial sale will void the Limited Warranty.

This Limited Warranty shall not extend to products or parts which have been damaged by negligent use, misuse, alteration, accident or which have been improperly/inadequately maintained. This Limited Warranty extends solely to products manufactured by GSI.

Prior to installation, the end-user has the responsibility to comply with federal, state and local codes which apply to the location and installation of products manufactured or sold by GSI.

This equipment shall be installed in accordance with the current installation codes and applicable regulations which should be carefully followed in all cases. Authorities having jurisdiction should be consulted before installations are made.

G S I G R O U P



GSI Group
1004 E. Illinois St.
Assumption, IL 62510-0020
Phone: 1-217-226-4421
Fax: 1-217-226-4420
www.gsiag.com